

Single Row Ball Slewing Bearing (Inches Series) UNGEARED

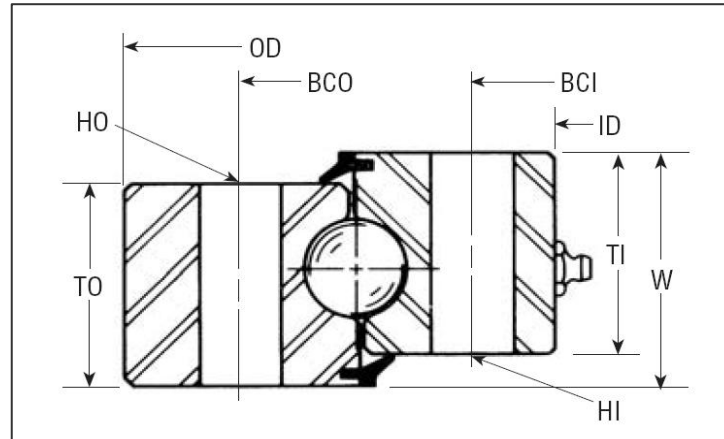

Designation	Reference No.	Outline dimensions (inches)						Mounting holes		Hole dia. HI/HO	Approx. wt. (lbs.)	Reference moment load rating ft. lbs.
		OD	ID	W	TO/TI	BCO	BCI	No. holes				
								Inner	Outer			
NGSBI 11.81-5.71-1.97	MTO-145	11.811	5.709	1.968	1.732	10.63	6.89	16	16	0.562	37	26,000
NGSBI 12.29-5.71-1.97	MTO-145X	12.286	5.709	1.968	1.732	10.63	6.89	16	16	0.594	41	30,600
NGSBI 14.37-8.27-1.58	MTO-210•	14.37	8.268	1.575	1.496	13.19	9.449	20	16	0.562	38	44,500
NGSBI 14.69-8.27-1.97	MTO-210X	14.686	8.268	1.968	1.732	13.19	9.449	20	16	0.594	48	52,100
NGSBI 16.54-10.43-1.97	MTO-265	16.535	10.433	1.968	1.732	15.354	11.614	24	18	0.562	54	62,000
NGSBI 17.09-10.43-1.97	MTO-265X	17.086	10.433	1.968	1.732	15.354	11.614	24	18	0.594	61	71,900
NGSBI 20.49-12.75-2.06	MTO-324	20.486	12.75	2.062	2	18.875	14.375	20	20	.625 UNC	105	102,400

Single Row Ball Slewing Bearing (Inches Series)

EXTERNAL GEAR

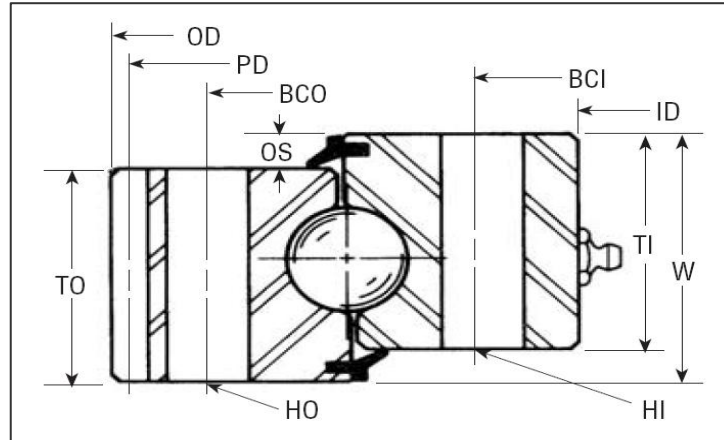

Designation	Reference No.	Outline dimensions (inches)							Hole data				Gear data—20° pressure angle					Approx. wt. lbs.	Reference moment loading rating (lbs.)ft.-lbs.		
		OD	ID	W	TO	TI	OS	BCO	No. holes outer	HO	BCI	No. holes inner	HI	PD	DP	FW	No. teeth			BHN core hardness	Max. tangential tooth load
EGSBI 12.29-5.71-1.97	MTE-145	12.286	5.709	1.968	1.732	1.732	0.236	10.63	16	0.562	6.89	16	0.562	12	5/7*	1.732	60	277-321	7,140	38	26,000
EGSBI 12.29-5.71-1.97	MTE-145X	12.286	5.709	1.968	1.732	1.732	0.236	10.63	16	0.594	6.89	16	0.594	12	5/7*	1.732	60	277-321	7,140	38	30,600
EGSBI 14.69-8.27-1.58	MTE-210*	14.686	8.268	1.575	1.496	1.496	0.079	13.19	16	0.562	9.449	20	0.562	14.4	5/7*	1.496	72	262-302	5,810	38	44,500
EGSBI 14.69-8.27-1.97	MTE-210X	14.686	8.268	1.968	1.732	1.732	0.236	13.19	16	0.594	9.449	20	0.594	14.4	5/7*	1.732	72	277-321	7,290	44	52,100
EGSBI 17.09-10.43-1.97	MTE-265	17.086	10.433	1.968	1.732	1.732	0.236	15.354	18	0.562	11.614	24	0.562	16.8	5/7*	1.732	84	277-321	7,330	57	62,000
EGSBI 17.09-10.43-1.97	MTE-265X	17.086	10.433	1.968	1.732	1.732	0.236	15.354	18	0.594	11.614	24	0.594	16.8	5/7*	1.732	84	277-321	7,330	57	71,900
EGSBI 20.49-12.75-2.06	MTE-324	20.486	12.75	2.062	2.022	2.022	0.04	18.875	20	.625UNC	14.375	20	.625UNC	20.2	5/7*	2.022	101	277-321	8,700	98	101,700
EGSBI 20.49-12.77-2.38	MTE-324X	20.486	12.77	2.375	2.063	2.063	0.312	18.875	20	0.688	14.375	20	0.688	20.2	5/7*	2.063	101	277-321	8,863	99	102,100
EGSBI 24.65-16.25-2.38	MTE-415	24.65	16.25	2.375	2.063	2.063	0.312	22.25	16	0.813	17.75	20	0.813	24.25	4**	2.063	97	277-321	10,420	132	159,200
EGSBI 26.90-18.50-2.38	MTE-470	26.9	18.5	2.375	2.063	2.063	0.312	24.5	18	0.813	20	24	0.813	26.5	4**	2.063	106	277-321	10,460	147	191,600

Single Row Ball Slewing Bearing (Inches Series)

EXTERNAL GEAR

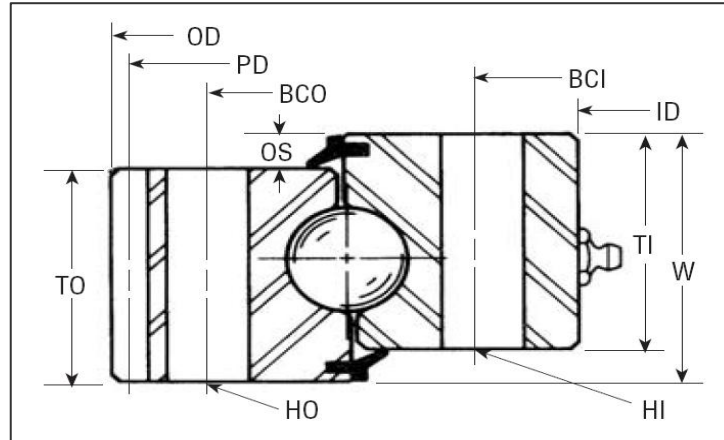

Designation	Reference No.	Outline dimensions (inches)							Hole data				Gear data—20° pressure angle					Approx. wt. lbs.	Reference moment loading rating (lbs.)ft.-lbs.		
		OD	ID	W	TO	TI	OS	BCO	No. holes outer	HO	BCI	No. holes inner	HI	PD	DP	FW	No. teeth			BHN core hardness	Max. tangential tooth load
EGSBI 29.65-21.25-2.38	MTE-540	29.65	21.25	2.375	2.063	2.063	0.312	27.25	24	0.813	22.75	28	0.813	29.25	4**	2.063	117	277-321	10,520	163	232,000
EGSBI 33.53-23.13-2.88	MTE-590	33.534	23.125	2.875	2.563	2.563	0.312	30.625	18	0.938	24.875	24	0.938	33	3**	2.563	99	277-321	17,290	283	338,700
EGSBI 38.20-27.75-2.88	MTE-705	38.201	27.75	2.875	2.563	2.563	0.312	35.25	24	0.938	29.5	28	0.938	37.667	3**	2.563	113	277-321	17,390	332	443,200
EGSBI 41.85-28.75-3.25	MTE-730	41.85	28.75	3.25	2.88	2.88	0.375	38	20	1.063	31	24	1.063	41.2	2.5**	2.63	103	277-321	21,290	498	588,000
EGSBI 47.44-34.25-4.25	MTE-870	47.444	34.25	4.25	3.875	3.875	0.375	43.875	24	1.188	36.25	28	1.188	46.8	2.5**	3.875	117	277-321	31,620	780	873,800

Note: Bearings with suffi x "X" in the model number provide additional load capacity.

They will require 9/16" diameter fasteners.

*Fellows Stub

**USA Standard Stub

Mating Pinions for Inches-Series Bearing

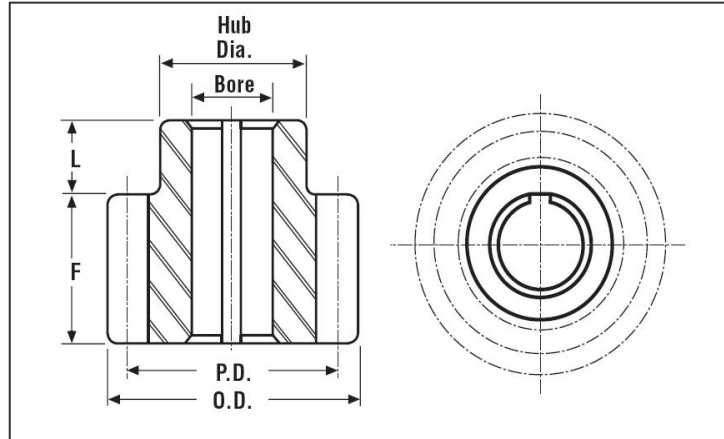

Designation	Pinion number	No. of teeth	Diametra l pitch	Face (F)	Hub length (L)	Pitch dia.	Outer dia.	Hub dia.	Stock bore	Square Keyway
MTE-145 thru MTE-324	39201001	17	5/7	2.25	3.125	3.4	3.686	2.906	1	0.25
MTE-415 thru	39200001	14	4	2	0.88	3.5	3.9	2.88	1	
MTE-540	39200002	17	4	2	0.88	4.25	4.65	3.63	1	
MTE-590 thru	39200003	14	3	2	0.88	4.667	5.2	3.88	1.25	
MTE-705	39200004	17	3	2	0.88	5.667	6.2	4.88	1.25	
Tolerances			Ref.	Ref.	Ref.	Ref.	±.000 -010	Ref.	±.002 -000	