

A

## ENGINEERING

**A ENGINEERING**

<i>Bearing Types and Cages</i> .....	A4
<i>Determination of Applied Loads and Bearing Analysis</i> .....	A21
<i>Bearing Reactions, Dynamic Equivalent Loads and Bearing Life</i> .....	A27
<i>Bearing Tolerances, Inch and Metric</i> .....	A43
<i>Mounting Designs</i> .....	A73
<i>Fitting Practice</i> .....	A102
<i>Bearing Setting</i> .....	A140
<i>Lubrication and Seals</i> .....	A146
<i>Speed, Heat and Torque</i> .....	A163
<i>Conversion Tables</i> .....	A174



# ENGINEERING

# A



## INTRODUCTION

Timken is a leader in the advancement of bearing technology. Expert craftsmanship, well-equipped production facilities, and a continuing investment in technology programs ensure that our products are synonymous with quality and reliability. Today, our plants manufacture thousands of bearing types and sizes to handle a wide range of application requirements.

Anti-friction bearings inherently manage broad ranges of speed and many combinations of radial and thrust loads. Other important environmental conditions, such as low and high temperature, dust and dirt, moisture, and unusual mounting conditions, affect bearing operation.

This engineering section is not intended to be comprehensive, but does serve as a useful guideline in bearing selection. Where more complex bearing applications are involved, your Timken

representative should be consulted. The following topics are covered within this section:

- Bearing types
- Cages
- Internal clearances
- Tolerances
- Shaft and housing fits and shoulders
- Load ratings and life calculations
- Lubrication
- Materials
- Limiting speeds
- Duplex bearings and preloading

## BEARING SELECTION PROCESS

Bearing selection is a process for evaluating the suitability of bearings for specific industrial applications. The quality of the information available to make these selections will play a major role in determining the success of the bearing choice.

The first step in bearing selection is identifying the proper roller element type, whether it is a ball, needle, cylindrical, spherical or tapered roller bearing. Each roller bearing type has advantages and disadvantages that are specific to each design and will affect such things as the loads and speeds that the bearing can sustain in the application.

Next, assess the size constraints of the bearing envelope or available space. This is done by considering the minimum shaft diameter, maximum housing bore and available width within the application for the bearing. After the bearing envelope is defined, search the catalog for bearings with bores, outer diameters and widths that will fit within the bearing envelope. There may be several bearings with different load-carrying capacities available that fit within the envelope.

Determine which of these bearings will give the desired life in the application by performing a bearing life analysis for each bearing. The following sections in this catalog give a detailed explanation of how to perform bearing life analysis.

Once you have chosen the right bearing to handle the load requirements of your application, and the design options are chosen, the bearing selection is completed. These options include such features as cage type, cylindrical roller bearing flange arrangements, radial internal clearance or setting, precision level and lubrication. These options are selected based on the application's speed, temperature, mounting and loading conditions, and will enable you to achieve optimum bearing performance and life.

For a closer look, your Timken representative can provide you with expert computer analysis to give you the most detailed information for your bearing application.

Characteristic	Tapered Roller Bearing	Thrust Tapered Roller Bearing	Cylindrical Roller Bearing	Thrust Cylindrical Roller Bearing	Spherical Roller Bearing	Thrust Spherical Roller Bearing	Ball Bearing	Thrust Ball Bearing	Needle Roller Bearing	Thrust Needle Roller Bearing
Pure Radial Load	Excellent	Unsuitable	Excellent	Unsuitable	Excellent	Unsuitable	Good	Poor	Excellent	Unsuitable
Pure Axial Load	Good	Excellent	Unsuitable	Good	Fair	Excellent	Fair	Excellent	Unsuitable	Excellent
Combined Load	Excellent	Fair	Fair	Unsuitable	Excellent	Fair	Good	Poor	Unsuitable	Unsuitable
Moment Load	Fair	Poor	Unsuitable	Unsuitable	Unsuitable	Unsuitable	Good	Poor	Fair	Unsuitable
High Stiffness	Excellent	Excellent	Good	Excellent	Good	Good	Fair	Good	Good	Excellent
Quiet Running	Fair	Fair	Good	Poor	Fair	Poor	Excellent	Good	Good	Fair
Low Friction	Fair	Fair	Good	Poor	Fair	Fair	Excellent	Excellent	Good	Good
Misalignment	Poor	Poor	Poor	Unsuitable	Excellent	Excellent	Good	Poor	Poor	Poor
Locating Position (Fixed)	Excellent	Good	Fair	Fair	Good	Good	Good	Excellent	Unsuitable	Excellent
Non-Locating Position (Floating)	Good	Unsuitable	Excellent	Unsuitable	Fair	Unsuitable	Good	Unsuitable	Good	Unsuitable
Speed	Good	Good	Good	Poor	Fair	Fair	Excellent	Excellent	Good	Poor

# A BEARING TYPES AND CAGES

## BEARING TYPES

### RADIAL BALL BEARINGS

The basic types of Timken ball bearings are shown here. They are the non-filling slot or Conrad, which is identified by the suffix K and the filling slot designated by the suffix W.

The non-filling slot or Conrad bearing has uninterrupted raceway shoulders and is capable of supporting radial, thrust or combined loads. The filling slot type, which is assembled with more balls than a K-Type of the same size, has a greater capacity than the K-Type, but has limited thrust capacity due to the filling slots in the raceway shoulders.

Both K and W can be mounted with or without locknuts and either fixed or floating in their housings as illustrated here.

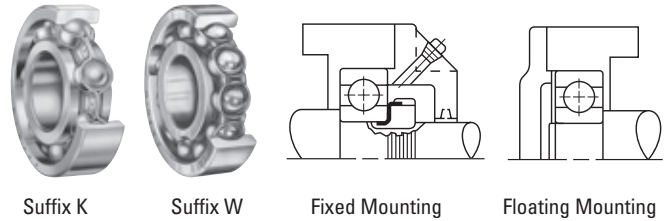

### ANGULAR CONTACT BALL BEARINGS

#### Single-Row Type

Single-row, angular contact ball bearings are designed for combination loading with high thrust capacity in one direction, and are suggested for applications where the magnitude of the thrust component is high enough to preclude the use of radial type ball bearings. They are dimensionally interchangeable with single-row radial bearings of corresponding sizes.

The angular contact ball bearing has a relatively large contact angle, high race depths, and a maximum complement of balls assembled through a counterbore in the outer ring. These features provide bearings with significantly more thrust capacity than radial bearings of the same size.

Angular contact bearings are used in such applications as gear reducers, pumps, worm drives, vertical shafts and machine tool spindles, where they are frequently mounted in various duplex arrangements as described in the duplex section.

#### Double-Row Type

Double-row, angular contact ball bearings are used effectively where heavy radial, thrust or combined loads demand axial rigidity of the shaft. This type is similar to a duplex pair of single-row bearings by virtue of its two rows of balls and angular-contact construction, which provide greater axial and radial rigidity than can be obtained by using a single-row radial bearing.

With the exception of small sizes, double-row ball bearings are made in the filling slot construction, and therefore, do not have as much thrust capacity as equivalent size single-row, angular contact bearings mounted in duplex pairs. Fixed and floating mountings of double-row bearings are shown. Smaller sizes are supplied with polymeric retainers.

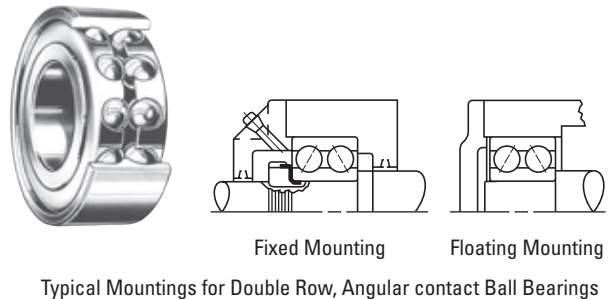
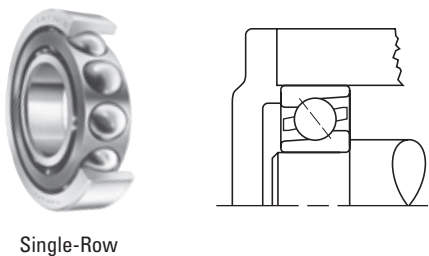

**BEARING TYPES AND CAGES** – *continued***BALL BEARINGS WITH SNAP RINGS (WIRELOC)**

Single-row radial bearings including those with seals or shields and open and shielded double-row types are available with snap rings, which provide a shoulder integral with the bearing, designed for mounting in through-bored housings. This feature is designated by adding the suffix "G" to the standard bearing number. Single shielded or sealed bearings with snap rings can be supplied with the snap ring on the same side or that opposite the shield or seal position.

These bearings are advantageous in automobile transmission design and in all applications where compactness is essential, or where it is difficult and costly to machine housing shoulders.

snap ring provides an adequate shoulder for the bearings without a sacrifice in bearing capacity. The thrust capacity of the snap ring in shear is considerably above the thrust capacity of the bearing.

Typical designs illustrating how mounting simplification can be accomplished through the use of snap ring bearings are shown (below).

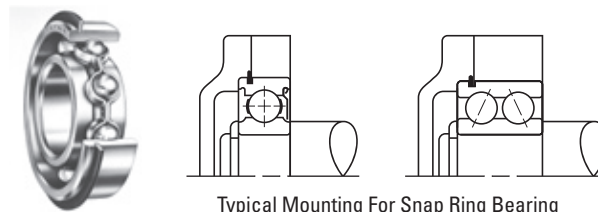

Typical Mounting For Snap Ring Bearing

**SUPER PRECISION BALL BEARINGS**

Every Timken Fafnir ball bearing manufactured is made to precision tolerances. The standard tolerances established by the Annular Bearing Engineers Committee (ABEC) are adhered to, and even the most liberal classification, ABEC 1 ensures a precision product by nature. Many applications in numerous types of machinery can be satisfactorily operated with ABEC 1 tolerance bearings.

However, for applications involving high speeds, extreme accuracy and rigidity in such equipment as high-grade machine tools, woodworking machines, gas turbines and sensitive precision instruments, a complete line of Timken Fafnir super precision ball bearings is manufactured to ABEC 7 and ABEC 9 tolerances.

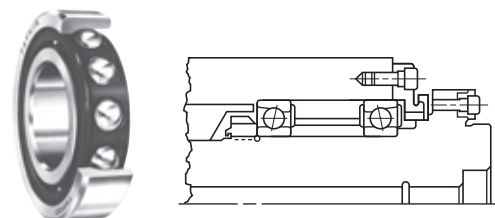

Typical Application For Super Precision Bearing

BEARING TYPES AND CAGES – *continued*

**BALL BEARINGS WITH LOCKING DEVICES**

By virtue of their independent locking devices, these bearings are suitable for mounting on straight shafting (no shoulders, etc.). They are often supplied with spherical outer rings for self-alignment at mounting. Mounted alignment is usually required because these bearings are generally assembled into pillow blocks or flanged cartridges, or other housings bolted to pedestals or frames independent of each other.

**Self-Locking (Eccentric) Collar**

Timken invented the eccentric self-locking collar to facilitate mounting of wide inner ring bearings. The self-locking collar eliminates the need for locknuts, lockwashers, shoulders, sleeves and adapters.

The locking collar has a counterbored recess eccentric with the collar bore. This eccentric recess engages or mates with an eccentric cam end of the bearing inner ring when the bearing is assembled on the shaft.

The collar is engaged on the inner ring cam of the bearing. This assembly grips the shaft tightly with a positive binding action that increases with use. No adjustments of any kind are necessary. The collar setscrew provides supplementary locking.

Easiest of all to install, wide inner ring ball bearings with self-locking collars are available in various sizes. These bearings shown with various seal and inner ring width variations serve many purposes in farm and industrial applications.



RA-RR Series  
Extended Inner Ring  
with Locking Collar



Shroud-Seal KRRB Series  
Wide Inner Ring  
with Locking Collar

**Setscrew Series Bearings**

The GYA-RRB and the GY-KRRB series relubricatable and non-relubricatable bearings are extended inner ring and wide inner ring type bearings with specially designed setscrews to lock on shafting. Positive contact land-riding R-Seals provide protection against harmful contaminants and retain lubricant. Extended inner ring bearings are used when space is at a premium and overturning loads are not a problem. The new wide inner ring setscrew series is available when additional surface contact on the shaft is a requirement for added stability.

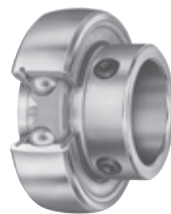

YA-RR Series

**Concentric Collar**

Using the concentric collar, the bearing is locked to the shaft by two setscrews, 120 degrees apart, tightened in the collar and passing through drilled holes in the inner ring. These units are suited for applications where space is limited and reversing shaft rotation is encountered.



GC-KRRB Series

**BEARING TYPES AND CAGES** – *continued***NEEDLE ROLLER BEARINGS**

Timken needle roller bearings are an economical alternative for applications requiring minimal space to carry a given load at a desired speed. Needle roller bearings can be an ideal choice because of their ability to handle a given level of speed and load capacity, yet have the smallest cross-section of all roller bearing types – and, at a very attractive price.

Timken offers both inch and metric nominal bearings in popular designs such as: drawn cups, radial caged needle rollers, machined ring, track rollers, thrust bearings, combined bearings, and drawn cup roller clutches. Most of these bearing types can be operated directly on a machined shaft of suitable quality, or with a matching inner ring where this requirement cannot be conventionally satisfied.

**Radial Caged Needle Rollers**

Timken Torrington needle roller and cage radial assemblies have a steel cage that provides both inward and outward retention for the needle rollers. The designs provide maximum cage strength consistent with the inherent high load ratings of needle roller bearings. Accurate guidance of the needle rollers by the cage bars allows for operation at high speeds. Needle roller and cage assemblies are manufactured with either one or two rows of needle rollers.

**Drawn Cup Bearings**

The outer ring in the form of a cup is accurately drawn, and no subsequent machining is performed to build the outer raceway. Drawn cup needle roller bearings are available in open ends or single, closed (to protect the shaft) end designs. They are also available with one or two integral seals. Other options include a single lubricating hole, and matching inner ring.

**Heavy-Duty (Machined) Needle Roller Bearings**

These bearings are available in a wide range of inch and metric sizes plus an array of design features including: integral seals, side flanges (or separate end washers), inner rings, oil holes, and single or double caged sets (or full complement) of rollers.

**Track Rollers**

Timken Torrington track rollers listed in this catalog have been designed with outer rings of large radial cross section to withstand heavy rolling and shock loads on track type or cam-controlled equipment. The outside diameters of the outer rings are either profiled or cylindrical. Profiled track rollers are designed to alleviate uneven bearing loading resulting from deflection, bending or misalignment in mounting. Stud-type track rollers are available with or without lip contact seals, or with shields. Yoke-type track rollers are designed for straddle mounting. Each yoke-type is available with either needle roller and cage radial assemblies, or with a single (or double) full complement row of cylindrical or needle rollers.

**Thrust Bearings**

Needle roller and cage thrust assemblies are available in a variety of inch or metric sizes. All types have very small cross-sections. If the back up surfaces cannot be used as raceways, hardened washers are available. Thrust bearings are available with needle rollers or heavier cylindrical rollers for high load carrying capacity.

**Combined (Radial and Thrust) Bearings**

Timken combined bearings consist of a radial bearing (needle roller bearing) and a thrust bearing (needle or other roller bearing). Some combined bearings are constructed similar to drawn cups, but with an added thrust bearing component. Like other needle bearings, these combined bearings can be matched with an optional inner ring or thrust washer as the opposing raceway.

**Roller Clutches**

Drawn cup roller clutches transmit torque between the shaft and housing in one direction and allow free overrun in the opposite direction. When transmitting torque, either the shaft or the housing can be the input member. Applications are generally described as indexing, backstopping or overrunning.

In many respects, construction is similar to that of drawn cup bearings, utilizing the same low profile radial section as drawn cup bearings. The precisely formed interior ramps provide surfaces against which the needle rollers wedge to positively lock the clutch with the shaft when rotated in the proper direction. These ramps formed during the operation of drawing the cup, are case hardened to assure long wear life. The incorporation of ramp forming into the cup drawing operation is a Timken manufacturing innovation that contributes much to the low cost of the unit.

BEARING TYPES AND CAGES – *continued*

NEEDLE ROLLER BEARING SELECTION

Because of the possible combinations of roller complement orientation, bearing cross-section thickness, and raceway construction, needle roller bearings should be given extra consideration for roller bearing applications selection. The table below should be used as a general guideline for the application of Timken needle roller bearings.

NEEDLE ROLLER BEARING CAPABILITY COMPARISON BASED ON SUITABLE OIL LUBRICATION

Bearing Design Design Bearing Capability	Needle Roller Type Assembly	Drawn Cup & Cage Radial Bearing Caged	Drawn Cup Needle Needle Roller Full Complement	Needle Roller Roller Bearing Inner Ring	Track Roller Bearing & Assembly	Needle Roller & Cage Thrust	Needle Rollers	Combination
Radial Load	High	Moderate	High	High	Moderate	None	Very high	High
Axial Load	None	None	None	None	Low	Very high	None	High
Limiting Speed	Very high	High	Moderate	Very high	Moderate	High	Moderate	Moderate
Slope Tolerance	Moderate	Moderate	Very low	Moderate	Moderate	Low	Very low	Low
Grease Life	High	High	Low	High	Moderate	Low	Low	Low
Friction	Very low	Very low	High	Very low	Low	Moderate	High	Moderate
Precision	Very high	Moderate	Moderate	High	High	High	Very high	High
Cross Section	Very low	Low	Low	Moderate	High	Very low	Very low	High
Cost	Low	Low	Low	High	High	Moderate	Very low	Very high



Radial Caged Needle Roller



Drawn Cup Needle Roller



Heavy-Duty Needle Roller

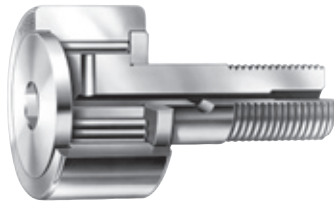

Track Roller



Thrust Needle Roller



Combined Needle Roller



Drawn Cup Roller Clutch



BEARING TYPES AND CAGES – *continued*

## RADIAL SPHERICAL ROLLER BEARINGS

The principle styles of radial spherical roller bearings are offered by Timken: CJ, YM, YMB, VCSJ and VCSM.

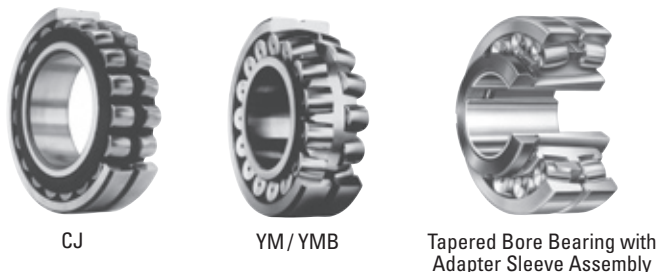

CJ

YM/YMB

Tapered Bore Bearing with  
Adapter Sleeve Assembly

YM bearings offer the greatest range of sizes in all series. They combine Timken design experience with proven performance in many industries.

All of the newer styles (CJ, YM and YMB) offer higher load ratings for longer life. CJ bearings include a stamped steel cage and are suitable for a broad range of general service applications. For extreme conditions of use, the YM and YMB style, with a machined brass cage, should be considered.

All styles are available in straight or tapered bores. Tapered bore bearings can be ordered by placing a “K” immediately after the numbers in the bearing description (e.g., 22311KYM).

Tapered bore bearings are available with adapter sleeve assemblies consisting of sleeve, locknut and washer. Adapter sleeve assemblies are designated SNW (e.g., SNW117).

Timken spherical roller bearings have been developed to accommodate radial and axial loads. The internal geometry allows the inner ring to accommodate misalignment. This capability is unique to spherical roller bearings allowing machine designers more tolerance and less restrictive assembly. Other data is listed.

Timken spherical roller bearings are available in ten dimensional series conforming to ISO and ANSI/ABMA standards. An illustration is presented below.

Optional features available with Timken spherical roller bearings:

**W33 Lubrication Groove and Oil Holes**

A lubrication groove and three oil holes are provided in the bearing outer ring. This eliminates the expense of machining a channel in the housing bore for introducing lubricant to the bearing. This design feature allows the lubricant to flow between the roller paths, through a single lubrication fitting. The lubricant moves laterally outward from the center of the bearing, reaching all contact surfaces and “flushing” the bearing. To order, add the suffix “W33” to the bearing number (e.g., 22216W33).

**W22 Selected Outside Diameter Bearings**

Bearings with selected outside diameters are required in some applications. Timken spherical roller bearings are available with reduced outside diameter tolerance. This allows a close control of the fit between the bearing and housing.

To specify this feature, add the suffix “W22” to the bearing number (e.g., 22216W22).

Additional features are available, consult your Timken representative for more information.

## RADIAL CYLINDRICAL ROLLER BEARINGS

## Standard Styles

A Timken cylindrical roller bearing consists of an inner and outer ring, a roller retaining cage, and a complement of controlled contour cylindrical rollers. Depending on the type of bearing, either the inner or the outer ring has two roller guiding ribs. The other ring is separable from the assembly and has one rib or none. The ring with two ribs axially locates the position of the roller assembly. The ground diameters of these ribs may be used to support the roller cage. One of the ribs may be used to carry light thrust loads when an opposing rib is provided.

The decision as to which ring should be double-ribbed is normally determined by considering assembly and mounting procedures in the application.

Types RU and RIU have double-ribbed outer and straight inner rings. Types RN and RIN have double-ribbed inner and straight outer rings. The use of either type at one position on a shaft is ideal for accommodating shaft expansion or contraction. The relative axial displacement of one ring to the other occurs with minimum friction while the bearing is rotating. These bearings may be used in two positions for shaft support if other means of axial location are provided.



SERIES

239

230

240

231

241

222

232

213

223

233

BEARING TYPES AND CAGES – continued

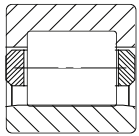

RIU, RU, NU

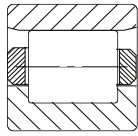

RIN, RN, N

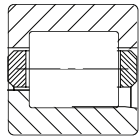

RIJ, RJ, NJ

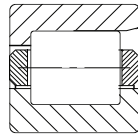

RIF, RF, NF

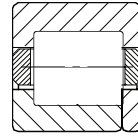

RIT, RT, NUP

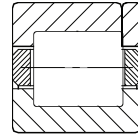

RIP, RP, NP

Types RJ and RIJ have double-ribbed outer and single-ribbed inner rings. Types RF and RIF have double-ribbed inner and single-ribbed outer rings. Both types can support heavy loads, as well as light unidirectional thrust loads. The thrust load is transmitted between the diagonally opposed rib faces in a sliding action. When limiting thrust conditions are approached, lubrication can become critical. Your Timken representative should be consulted for assistance in such applications. When thrust loads are very light, these bearings may be used in an opposed mounting to locate the shaft. In such cases, shaft endplay should be adjusted at time of assembly.

Types RT and RIT have double ribbed outer and single ribbed inner ring with a loose rib that allow the bearing to provide axial location in both directions. Types RP and RIP have a double-ribbed inner ring and a single-ribbed outer ring with a loose rib.

Types RT and RP (as well as RIT and RIP) can carry heavy radial loads and light thrust loads in both directions. Factors governing the thrust capacity are the same as for types RF and RJ bearings.

A type RT or RP bearing may be used in conjunction with type RN or RU bearings for applications where axial shaft expansion is anticipated. In such cases, the fixed bearing is usually placed nearest the drive end of the shaft to minimize alignment variations in the drive. Shaft endplay (or float) is determined by the axial clearance in the bearing.

The type NU, N, NJ, NF, NUP and NP are similar in construction to their 'R' counterparts, however, they conform to ISO and DIN standards for loose rib rings (thrust collars) and typical industry diameters over or under roller.

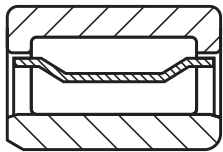

A-52xx-WS

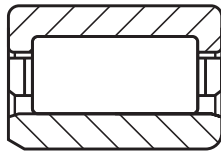

A-52xx-WM

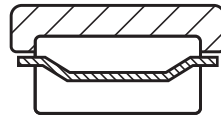

52xx-WS



A-52XX

5200 Metric Series

This series features enhanced radial load rating due to its internal design proportions. In this series, the outer ring is double-ribbed and the inner ring is full-width with a cylindrical O.D. The bearing also can be furnished without an inner ring for applications where radial space is limited. When so used, the shaft journal must be hardened to HRC 58 minimum, and the surface finished to 15 RMS maximum.

The bearing is usually furnished with a rugged stamped steel cage ("S" designation) and is land-riding on the outer ring ribs. The cage features depressed bars, which not only space rollers evenly, but retain them as a complete assembly with the outer ring. Cages of machined brass ("M" designation) are available for applications

where reversing loads or high speeds might indicate their need. Outer rings are made from bearing quality alloy steel. The inner rings are deep-case hardened to accommodate the hoop stresses resulting from heavy press fits.

The standard bearing is furnished with radial internal clearances designated as R6, tabulated in Radial Cylindrical Roller Section. Other internal clearances can be supplied upon request. Proper roller guidance is assured by integral ribs and roller end clearance control.

## BEARING TYPES AND CAGES – continued

## TAPERED ROLLER BEARINGS

## SINGLE-ROW BEARINGS

**TS - Single-Row**

This is the basic and the most widely used type of tapered roller bearing. It consists of the cone assembly and the cup. It is usually fitted as one of an opposing pair (see choice of mounting configuration). During equipment assembly, single-row bearings can be “set” to the required clearance (endplay) or preload condition to optimize performance.



TS

**TSF - Single-row, with flanged cup**

Variation on the basic single-row bearing-type TSF has a flanged cup to facilitate axial location and accurately aligned seats in a through-bored housing.



TSF

## TWO-ROW BEARINGS

**TDO - Double cup**

This has a one-piece (double) cup and two single cones. It is usually supplied complete with a cone spacer as a pre-set assembly. This configuration gives a wide effective bearing spread and is frequently chosen for applications where overturning moments are a significant load component. TDO bearings can be used in fixed (locating) positions or allowed to float in the housing bore, for example to compensate for shaft expansion. TDODC or TDOCD cups also are available in most sizes. These cups have holes in the O.D. that permit the use of pins to prevent cup rotation in the housing.

**TNA - Non-adjustable****TNASW - Non-adjustable with lubricant slots****TNASWE - Non-adjustable with lubricant slots and extended back face rib**

These three bearing types are similar to the TDO – comprised of a one-piece (double) cup and two cones. The cone front faces are extended so they abut, eliminating the need for a separate cone spacer. Supplied with a built-in clearance to give a standard setting range, as listed, these bearings provide a solution for many fixed or floating bearing applications where optimum simplicity of assembly is required.

Types TNASW and TNASWE are variations having chamfers and slots on the front face of the cone to provide lubrication through the shaft. Type TNASWE have extended back face ribs on the cones which are ground on the O.D. to allow for the use of a seal or stamped closure – typically for use on stationary shaft applications.

**TDI - Double cone****TDIT - Double cone with tapered bore**

Both comprise a one-piece (double) cone and two single cups. They are usually supplied complete with a cup spacer as a pre-set assembly. TDI and TDIT bearings can be used at fixed (locating) positions on rotating shaft applications. For rotating housing applications, the double cone of Type TDI can be used to float on the stationary shaft. Type TDIT has a tapered bore to facilitate removal when an interference fit is essential, yet regular removal is required.



TNA



TNASW



TNASWE



TDI



TDIT

**BEARING TYPES AND CAGES – continued**

**SPACER ASSEMBLIES**

Any two single-row bearings (Type-TS) can be supplied as a two-row, pre-set, ready-to-fit assembly by the addition of spacers, machined to pre-determined dimensions and tolerances. This principle is adopted in two standard ranges of spacer assemblies listed in the main sections of this guide: types “SS” and “SR”.

However, the concept can be applied to produce custom-made two-row bearings to suit specific applications. In addition to providing a bearing that automatically gives a pre-determined setting at assembly without the need for a manual setting, it is possible to modify the assembly width to suit an application, simply by varying the spacer lengths.

**SS - Two single-row assembly**

Often referred to as “snap-ring assemblies”, Type-SS consist of two basic single-row bearings (Type-TS). They are supplied complete with cone and cup spacers to give a pre-determined bearing setting when assembled. Type-SS have a specified setting range to suit the duty of the application. They have a cone spacer and a snap-ring, which also serves as the cup spacer, to give axial location in a through-bored housing.



**SR - Set-Right™ assembly**

Type-SR are made to a standard setting range, based on Timken’s Set-Right™ automated setting technique suitable for most industrial applications. They have two spacers and an optional snap-ring that may be used for axial location. Because both types are made up of popular sizes of single-row bearings, they provide a low cost option for many applications.

**THERE ARE THREE BASIC TYPES OF SPACER ASSEMBLIES**

**TYPE 2TS-IM (INDIRECT MOUNTING)**

These consist of two single-row bearings with a cone and cup spacer. In some applications the cup spacer is replaced by a shoulder in the bearing housing.

**TYPE 2TS-DM (DIRECT MOUNTING)**

These consist of two single-row bearings, with cones abutting and a cup spacer. They are generally used at fixed (locating) positions on rotating shaft applications.

**TYPE 2TS-TM (TANDEM MOUNTING)**

Where combined radial and thrust load capacity is required, but the thrust component is beyond the capacity of a single bearing (within a given maximum O.D.), two single-row bearings can be mounted in tandem. Appropriate cone and cup spacers are supplied. Consult your Timken representative for the most effective and economical solution.



2TS-IM



2TS-DM



2TS-TM

BEARING TYPES AND CAGES – *continued*

## PACKAGED BEARINGS

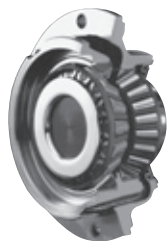

PINION PAC™



UNIPAC™



UNIPAC-PLUS™



AP™



SPTM

**Pinion Pac™**

The Pinion Pac™ bearing is a ready to install, pre-set and sealed package consisting of two rows of tapered roller bearings mounted in a carrier. It is custom designed for the final drive pinions of heavy commercial vehicles. The package gives the differential pinion builder considerable improvements in reliability, ease of assembly and supply logistics.

**UNIPAC™**

The UNIPAC™ bearing is a two-row tapered roller bearing, supplied as a maintenance free, pre-set, pre-lubricated and sealed package. Originally designed for the high-volume needs of passenger car wheels, the UNIPAC bearing now has wider application in wheel hubs of heavy vehicles as well as in industrial equipment.

The UNIPAC bearing provides improvements in reliability, ease of assembly and supply logistics.

**UNIPAC-PLUS™**

The UNIPAC-PLUS™ bearing is a ready-to-install, pre-set, sealed and lubricated-for-life two-row assembly with a flanged outer ring. It is a maintenance-free, heavy vehicle wheel package. The package enables a reduction in the wheel weight by eliminating the traditional wheel hub and has the advantage of improving reliability, assembly and supply logistics. An added advantage for disc-brake equipped axles is ease of mounting.

**AP™ Bearing**

The AP™ bearing is a self-contained assembly, made in a wide range of sizes. It consists of two single cones, a counterbored double cup, a backing ring, two radial seals, an end cap and cap screws. The AP bearing is supplied as a pre-set, pre-lubricated and sealed package.

**SP™ Bearing**

Similar in concept to AP bearings, the SP™ bearing is designed specifically for journal bearings on high-speed rail applications. The SP bearing type differs from the AP bearing in that SP bearings have labyrinth seals, are more compact in size, and are manufactured to metric boundary dimensions.

## SEALED BEARINGS

**TSL**

The TSL incorporates a DUO-FACE® PLUS seal, making it an economical choice for grease lubricated applications at moderate speeds.



TSL



BEARING TYPES AND CAGES – continued

PRECISION BEARINGS

TS and TSF single-row bearings

These bearings are similar in design to the types described on page A11. They are only produced in high-precision quality, to be used in machine tool spindles, printing press cylinders and other applications where accuracy of rotation is required.

TSHR - Hydra-Rib™ bearing with preload adjustment device

For many applications, notably in the machine tool industry, bearings are required to run at high speeds with a controlled preload setting. The Hydra-Rib™ bearing has a “floating” cup rib controlled by hydraulic or pneumatic pressure, which ensures that the required bearing preload is maintained irrespective of the differential expansions or changes in loading taking place within the system.



TSHR

HIGH SPEED BEARINGS

TSMA - Single-row, with axial oil provision

Some applications require extreme high-speed capability, where special lubrication methods must be provided.

The TSMA is a single-row bearing with a special provision for lubrication of the critical roller-rib contact area to ensure adequate lubrication at high speeds. The concept works by capturing oil in a manifold (attached to the cone), which is then directed to the rib-roller contact area through holes drilled axially through the large cone rib. Consult your Timken representative for other high-speed bearing designs with specialized lubrication methods.



TSMA

TXR - Crossed roller bearing

A crossed roller bearing is two sets of bearing races and rollers brought together at right angles – with alternate rollers facing opposite directions – within a section height not much greater than that of a TS bearing. The steep angle, tapered geometry of the bearing causes the load-carrying center of each of the races to be projected along the axis, resulting in a total effective bearing spread many times greater than the width of the bearing itself. This type of bearing offers a high resistance to overturning moments.

The normal design of the bearing is type TXRDO, which has a double cup and two cones, with rollers spaced by polymer separators. Crossed roller bearings are manufactured in precision classes.



TXR

OTHER TWO-ROW BEARINGS

Type TDIE - Extended double cone

Type TDIA

These two-row bearings are designed for applications where it is required to lock the loose-fitted cone to a shaft, with provision also for effective closure or sealing – (typically on pillow blocks, disc-harrow and similar agricultural machinery shafts and line shafts).

Type TDIE is available in two forms: cylindrical bore with the cone extended at both ends and provisions for setscrews and locking collars at each end, or with an inherently self-locking square bore – ideal for farm machinery applications.

Type TDIA is similar to type TDIE with a cylindrical bore. There is a provision for a locking collar at one end only. The compact configuration is suited to pillow blocks and similar applications.

On all types, the hardened and ground O.D. of the cone extension provides an excellent surface for effective closure or sealing.

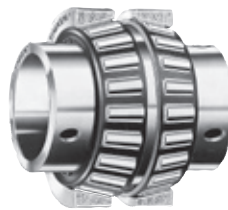

TDIE

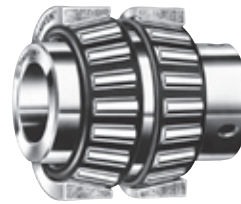

TDIA

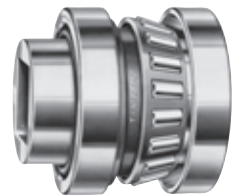

TDIE (Square Bore)

Type TNASWH - Non adjustable, heavy-duty, double cup

Type TNASWHF - Non adjustable, heavy-duty, with flanged double cup

These are two-row bearing assemblies with two cones and a one-piece cup, similar to type TNASWE listed in this guide.

The cups have a heavy wall section, allowing the bearings to be used directly as steady rest rollers, in sheet and strip levellers or, with a flange (Type-TNASWHF), as a complete wheel assembly for use on rails.

The cup is extended at both ends and counterbored to accept stamped closures. The bearings can be supplied with these ready-fitted as a unit assembly (but not pre-lubricated).

Rubbing seals are available for certain sizes.



TNASWHF



TNASWH

**BEARING TYPES AND CAGES** – *continued***FOUR-ROW BEARING ASSEMBLIES**

Four-row bearings combine the inherent high-load, radial/thrust capacity and direct/indirect mounting variations of tapered roller bearings into assemblies of maximum load rating in a minimum space. Their main application is on the roll necks of rolling mill equipment.

All four-row bearings are supplied as pre-set matched assemblies, with all components numbered to ensure correct installation sequence.

**Type-TQO****Type-TQOW**

These pairs of directly mounted bearings consist of two double cones, two single and one double cup, with a cone spacer and two cup spacers. These types are used on roll necks of low- and medium-speed rolling mills, applied to the necks with a loose fit. When the fillet and/or filler rings do not have lubrication slots, they are provided in the faces of the bearing cones (Type-TQOW). Slots in the cone spacer permit lubricant to flow from the bearing chamber to the roll neck. The cone spacers also are hardened to minimize face wear.

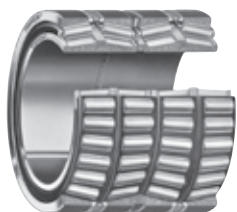

TQO

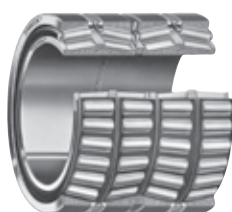

TQOW



TQITS



TQITSE

**Type-TQITS****Type-TQITSE**

The main feature of these bearings is a tapered bore – the taper being matched and continuous through the cones. This permits an interference fit on the backup rolls of high-speed mills, where a loose cone fit of a straight bore type TQO bearing could result in excessive neck wear.

These four-row bearings consist of two pairs of indirectly mounted bearings: two single and one double cone, four single cups and three cup spacers. The relevant faces of the cones are extended so that they abut, eliminating the need for cone spacers. The indirect mounting of the bearing pairs increase the overall effective spread of the bearing, to give optimum stability and roll rigidity.

Type TQITSE is the same as TQITS, but has an extension to the large bore cone adjacent to the roll body. This not only provides a hardened, concentric and smooth surface for radial lip seals, but also improves roll neck rigidity by eliminating a fillet ring. This allows the centerline of the bearing to move closer to the roll body. It also permits shorter and less costly rolls.

**Sealed roll neck**

The sealed roll neck bearing is similar to the TQO. A specially designed sealing arrangement is incorporated in the bearing to endure highly contaminated environments. The special seal design is built into the bearing to eliminate contamination from outside the bearing envelope and extend the useful life.



Sealed Roll Neck Bearing

**THRUST BEARINGS**

Standard types of thrust bearings manufactured by Timken are included in this section. Each type is designed to take thrust loads, but four types (TVL, DTVL, TTHD and TSR) accommodate radial loads as well. All types reflect advanced design concepts, with large rolling elements for maximum capacity. In roller thrust bearings, controlled contour rollers are used to insure uniform, full-length contact between rollers and raceways with resultant high capacity. Thrust bearings should operate under continuous load for satisfactory performance.

- Type TVB** – Grooved race thrust ball bearing
- Type TVL** – Angular contact thrust ball bearing
- Type DTVL** – Two direction angular contact thrust ball bearing
- Type TP** – Thrust cylindrical roller bearing
- Type TPS** – Self-aligning thrust cylindrical roller bearing
- Type TTHD** – Thrust tapered roller bearing
- Type TSR** – Thrust spherical roller bearing
- Type TTVF** – V-Flat thrust tapered roller bearing
- Type TTVS** – Self-aligning V-Flat thrust tapered roller bearing
- Type TTSP** – Steering pivot thrust cylindrical roller bearing

BEARING TYPES AND CAGES – *continued*

**Thrust Ball Bearings**

Thrust ball bearings are used for lighter loads and higher speeds than thrust roller bearings.

Type TVB ball thrust bearing is separable and consists of two hardened and ground steel washers with grooved raceways, and a cage that separates and retains precision-ground and lapped balls. The standard cage material is brass, but this may be varied according to the requirements of the application. Timken Standard Tolerances for Type TVB bearings are equivalent to ABEC 1 where applicable, but higher grades of precision are available.

Type TVB bearing provides axial rigidity in one direction and its use to support radial loads is not suggested. Usually the rotating washer is shaft-mounted. The stationary washer should be housed with sufficient O.D. clearance to allow the bearing to assume its proper operating position. In most sizes both washers have the same bore and O.D. The housing must be designed to clear the O.D. of the rotating washer, and it is necessary to step the shaft to clear the bore of the stationary washer.

Type TVL is a separable angular contact ball bearing primarily designed for unidirectional thrust loads. The angular contact design, however, will accommodate combined radial and thrust loads since the loads are transmitted angularly through the balls.

The bearing has two hardened and ground steel rings with ball grooves and a one-piece brass cage that spaces the ball complement. Although not strictly an angular ball bearing, the larger ring is still called the outer ring, and the smaller the inner ring. Timken Standard Tolerances for type TVL bearings are equivalent to ABEC 1 where applicable, but higher grades of precision are available.

Usually the inner ring is the rotating member and is shaft-mounted. The outer ring is normally stationary and should be mounted with O.D. clearance to allow the bearing to assume its proper operating position. If combined loads exist, the outer ring must be radially located in the housing.

Type TVL bearings should always be operated under thrust load. Normally, this presents no problem as the bearing is usually applied on vertical shafts in oil field rotary tables and machine tool indexing tables. If constant thrust load is not present, it should be imposed by springs or other built-in devices.

Low friction, cool running and quiet operation are advantages of this type of TVL bearing, which may be operated at relatively high speeds. The bearing also is less sensitive to misalignment than other types of rigid thrust bearings.

DTVL is similar in design to TVL except the DTVL has an additional washer and ball complement permitting it to carry moderate thrust in one direction and light thrust in the other direction.

**Thrust Cylindrical Roller Bearings**

Thrust cylindrical roller bearings withstand heavy loads at relatively moderate speeds. Standard bearings can be operated at bearing O.D. peripheral speeds of 3000 fpm (15 m/s). Special design features can be incorporated into the bearing and mounting to attain higher operating speeds.

Because loads are usually high, extreme pressure (EP) lubricants should be used with roller thrust bearings. Preferably, the lubricant should be introduced at the bearing bore and distributed by centrifugal force.

All types of thrust roller bearings are made to Timken Standard Tolerances. Higher precision may be obtained when required.

Type TP thrust cylindrical roller bearing has two hardened and ground steel washers, with a cage retaining one or more controlled contour rollers in each pocket. When two or more rollers are used in a pocket, they are of different lengths and are placed in staggered position in adjacent cage pockets to create overlapping roller paths. This prevents wearing grooves in the raceways and prolongs bearing life.

Because of the simplicity of their design, Type TP bearings are economical. Since minor radial displacement of the raceways does not affect the operation of the bearing, its application is relatively simple and often results in manufacturing economies for the user. Shaft and housing seats, must be square to the axis of rotation to prevent initial misalignment problems.

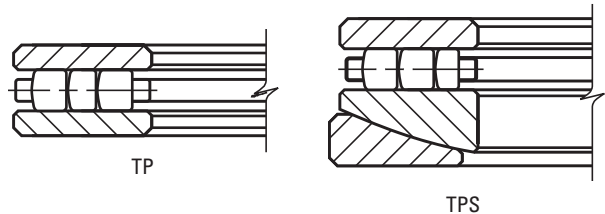

Type TPS bearings are the same as Type TP bearings except one washer is spherically ground to seat against an aligning washer, thus making the bearing adaptable to initial misalignment. Its use is not suggested for operating conditions where alignment is continuously changing (dynamic misalignment).

**Thrust Spherical Roller Bearings**

**Type-TSR**

The TSR thrust spherical roller bearing design achieves a high thrust capacity with low friction and continuous roller alignment. The bearings can accommodate pure thrust loads as well as combined radial and thrust loads. Typical applications are air regenerators, centrifugal pumps and deep well pumps. Maximum axial misalignment between inner and outer ring is  $\pm 2.5$  degrees.

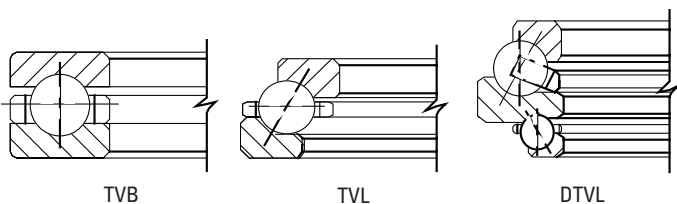
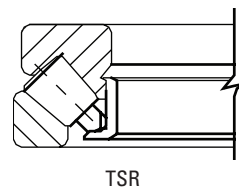



**BEARING TYPES AND CAGES** – *continued***Thrust Tapered Roller Bearings****Type-TTHD**

Type TTHD thrust tapered roller bearing has an identical pair of hardened and ground steel washers with conical raceways, and a complement of controlled contour tapered rollers equally spaced by a cage.

In the design of Type TTHD, the raceways of both washers and the tapered rollers have a common vertex at the bearing center. This assures true rolling motion.

TTHD bearings are well-suited for applications such as crane hooks, where extremely high thrust loads and heavy shock must be resisted and some measure of radial location obtained.

For very low-speed, heavily loaded applications, these bearings are supplied with a full complement of rollers for maximum capacity and are identified in the table of dimensions. For application review of the full complement Type TTHD bearing, consult your Timken representative.

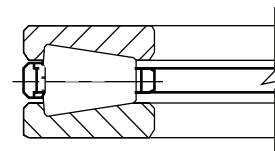

TTHD

**Type-TTVF****Type-TTHDFL****Type-TTHDSX**

V-Flat Tapered Roller bearings (TTVF and TTVS) combine the best features of thrust tapered and cylindrical roller bearings, offering the highest possible capacity of any thrust bearing of its size. V-Flat design includes one flat washer and the second with a tapered raceway matching the rollers. Design was originally developed for screwdown applications in metal rolling mills where thrust loads exceeding one million pounds are common. These bearings have exceptional dynamic capacity within a given envelope and provide superior static capacity. They have been highly successful in heavily loaded extruders, in cone crushers and other applications where a wide range of operating conditions are found.

**Type-TTVS****Type-TTHDSV**

Most sizes utilize cages with hardened pins through the center of the rollers, allowing closer spacing of the rollers to maximize capacity. Smaller sizes have cast brass cages, carefully machined to permit full flow of lubricant.

Self-aligning V-Flat bearings (TTVS) employ the same basic roller and raceway design, except the lower washer is in two pieces, with the contacting faces spherically ground permitting self-alignment under conditions of initial misalignment. TTVS bearings should not be used if dynamic misalignment (changing under load) is expected.

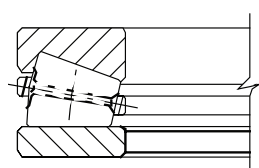

TTVF

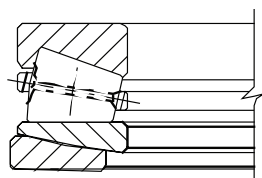

TTVS



TTHDFL



TTHDSV



TTHDSX

**TTC - Cageless****TTSP - Steering pivot**

There are two basic types of Timken thrust bearings designed for specific fields of duty where the only load component is thrust, TTC and TTSP. The TTC bearing uses a full complement of rollers without a cage and is used when the speeds are slow. The TTSP bearing uses a cage and was designed for the oscillating motion of steering pivot positions.



TTC



TTSP

**BEARING TYPES AND CAGES – continued**  
**CAGES**

Cages (sometimes referred to as rolling element separators or retainers) perform an important function in the proper operation of rolling bearings. They serve to maintain uniform rolling element spacing in the races of the inner and outer rings of the bearings as the rolling elements pass into and out of the load zones. Cage types in several materials and configurations have been developed by Timken to meet various service requirements. Temperature limitations are described later in this section.

Some of the materials from which cages are made include pressed steel, pressed brass, machined brass, machined steel and compositions of various synthetic materials.

**STEEL CAGES FOR RADIAL BALL BEARINGS**

Steel cages are generally ball-piloted and are available in the following types:

**Pressed Steel Finger Type Cages (SR)**

Light in weight and made from strong, cold rolled steel, the pressed steel cage because of its compactness is the optimum design for use in shielded and sealed bearings which must conform to ABEC boundary dimensions. This is a general purpose design and is frequently used for ABEC 1 ball bearing sizes.



**Pressed Steel Welded Cages (WR)**

The welded steel cage provides greater strength, increased rigidity, and better pocket alignment than the finger type. The projection welding of the cage halves eliminates weakening notches or holes and fingers or rivets. It assures better mating of cage halves circumferentially and radially.



This construction also provides more uniformity of ball to pocket clearance. Improved pocket geometry permits higher speeds, reduces cage wear, provides cooler operation, and improves and extends lubricant life. This cage is standard in most radial non-filling slot bearings of the open, shielded, and sealed types.

**MOLDED CAGES FOR RADIAL BALL BEARINGS**

Molded cages are either ball piloted or land piloted and are available in the following types:

**Nylon (PRB)**

One-piece molded snap-in 6/6 nylon cages are specially processed to provide:

- Toughness at moderately high and low temperatures
- Resistance to abrasion
- Resistance to organic solvents, oils and grease
- Natural lubricity
- Long term service at temperatures up to +120° C (+250° F)
- Dimensional stability

These cages offer superior performance in applications involving misalignment due to their greater flexibility.



PRB molded nylon cages provide uniformity of ball pocket clearances for consistent operation. They are suitable for temperatures up to +120° C (+250° F) continuous operation and can tolerate +150° C (+300° F) for short periods.

These cages are available in conrad (K) bearings and are standard for the more popular wide inner ring bearing series.

**BEARING TYPES AND CAGES** – *continued***Reinforced Nylon (PRC)**

Molded 6/6 nylon reinforced with 30 percent (by weight) glass fibers. This material is used primarily for one-piece ring piloted cages used in precision grades of angular contact bearings.

PRC cages offer outstanding strength and long term temperature resistance. Molded to very close tolerances and uniformity, combined with light weight design, they permit higher speeds and reduced noise. They are suitable for temperatures up to +150° C (+300° F).

PRC cages are usually the one piece outer piloted "L" type design, but are also available in one piece ball controlled designs.

**Special Molded Cages**

For very high speeds or very high temperature applications special materials can be used. Nylon with a PTFE additive is available for molded cages required for high speed applications. For applications involving high operating temperatures (up to +232° C, +450° F) molded cages made of fiber reinforced polyphenylene sulfide can be made.

For availability of these special cages please consult your Timken representative.

**Brass and Steel Cages**

Brass cages are generally installed in bearings which are designed for use on heavily loaded applications, such as, deep well pumps, woodworking machinery, and heavy construction machinery. The following types of Timken brass cages are available:

**Iron Silicon Brass Cage (SMBR) and Machined Steel Cage (MSR)**

The SMBR and MSR cages are ring piloted. The advantages of these cages are high strength even at elevated temperatures (see chart on page A167) as well as high-speed capability due to the ring piloted construction. In many cases these cages are silver plated for use in applications requiring high reliability.

They are available in both ball and roller bearings.

**Cast Brass Cage (BR)**

This cage, a ball piloted brass retainer designated by the letters BR, utilizes two identical halves which are riveted together.



BR



MBR

**Machined Brass Cage (MBR)**

These cages are machined all over to provide ring riding surfaces and good static and dynamic balance. They are commonly incorporated as inner ring piloted designs in the 7000 angular contact product family. Because of their superior strength, these cages are generally used on heavily loaded applications such as, deep well pumps, woodworking machinery, and heavy construction machinery.

**Composition Cages (CR)**

Composition cages combine light weight, precision and oil-absorbing features which are particularly desirable for use on high speed applications. This (CR) cage, is a ring piloted type and is particularly associated with the outer-ring piloted, extra precision WN series bearings.

**Special Cages**

For certain very high contact angle, light section aircraft bearings, molded nylon "snake" cages are employed. Cages are also made with high temperature materials (see page A167) in the various configurations described above.

For availability of special cages please contact your Timken representative.



**BEARING TYPES AND CAGES** – *continued*

**CAGES FOR SPHERICAL ROLLING BEARINGS**

**Brass Cages**

YM Bearing cages are one-piece design centrifugally cast and precision machined. The rugged construction of this cage type provides an advantage in more severe applications. Due to its design this cage permits YM bearings to incorporate greater load carrying capabilities.

The open end design permits lubricant to reach all surfaces easily assuring ample lubrication and a cooler running bearing.



YM Cage



CJ

**Stamped Steel Cages (CJ)**

These cages are used in CJ bearings and are designed to permit extra load carrying capabilities in the bearing. Two independent cages, one for each row of rollers, are assembled in an individual bearing.

**Pin Type Cages**

Large diameter spherical roller bearings can be supplied with these cages. The design of pin type cages permits an increased roller complement thus giving the bearing enhanced load carrying ability. Consult your Timken representative for suggestions on the application of this cage.

**CAGES FOR RADIAL CYLINDRICAL ROLLER BEARINGS**

**Brass Cages**

These are primarily roller guided cages with cylindrical bored pockets. They are used with the standard style roller bearings.

**Stamped Steel Cages**

Stamped steel cages of varying designs are available in the standard style cylindrical roller bearings.

The stamped steel cage for the 5200 series is a land riding cage piloted by the outer ring ribs. The cage features depressed bars which not only space rollers evenly but retain them as a complete assembly with the outer ring.



Brass Cage

**CAGES FOR TAPERED ROLLER BEARINGS**

**Stamped Steel Cages**

The cages are of compact space savings design and in some cases permit increased load-carrying capabilities to be incorporated into the bearing. They are roller riding with bridges positioned above the pitch line to retain the rollers within the cone.

**Machined Cages**

These heavy section ruggedly constructed cages are fully machined and are land riding on the thrust and toe flange O.D. of the cone (inner ring). The bridges between the straight through machined roller pockets are staked above the pitch line to retain the rollers with the cone.

**Pin Type Cages**

This steel cage design features a pin which fits closely with a bored hole in the roller. The rollers can thus be retained with a minimum space between the rollers so that an increased complement of rollers can be incorporated. This results in greater load carrying capabilities in the bearing.

## DETERMINATION OF APPLIED LOADS AND BEARING ANALYSIS

## SUMMARY OF SYMBOLS USED TO DETERMINE APPLIED LOADS AND BEARING ANALYSIS

Symbol	Description	Units	Symbol	Description	Units
$a_1$	Reliability Life Factor		$k$	Centrifugal Force Constant	lbf/RPM <sup>2</sup>
$a_2$	Material Life Factor		$k_1$	Bearing Torque Constant	
$a_3$	Operating Condition Life Factor		$k_4, k_5, k_6$	Dimensional Factor to calculate heat generation	
$a_{3d}$	Debris Life Factor		$K$	Tapered Roller Bearing Radial-to-Axial Dynamic Load Rating Factor	
$a_{3h}$	Hardness Life Factor		$l$	Thrust Needle Roller Length	mm, in.
$a_{3k}$	Load Zone Life Factor		$L$	Lead, Axial Advance of a Helix for One Complete Revolution	mm, in.
$a_{3l}$	Lubrication Life Factor		$L$	Distance between bearing geometric center lines	mm, in.
$a_{3m}$	Misalignment Life Factor		$m$	Gearing Ratio	
$a_{3p}$	Low Load Life Factor		$M$	Bearing Operating Torque or Moment	N-m, N-mm, lb-in.
$a_e$	Effective Bearing Spread	mm, in.	$n$	Bearing Operating Speed or General Term for Speed	rot/min, RPM
$b$	Tooth Length	mm, in.	$n_G$	Gear Operating Speed (RPM)	rot/min, RPM
$c_1, c_2$	Linear Distance (positive or negative)	mm, in.	$n_P$	Pinion Operating Speed (RPM)	rot/min, RPM
$C$	Dynamic Radial Load Rating	N, lbf	$n_W$	Worm Operating Speed (RPM)	rot/min, RPM
$C_0$	Static Load Rating	N, lbf	$N_G$	Number of Teeth in the Gear	
$C_p$	Specific Heat of Lubricant	J/(kg · °C), BTU/(lb · °F)	$N_P$	Number of Teeth in the Pinion	
$d$	Bearing bore diameter	mm, in.	$N_S$	Number of Teeth in the Sprocket	
$d_0$	Mean inner race diameter	mm, in.	$P_0$	Static Equivalent Load	N, lbf
$d_c$	Distance Between Gear Centers	mm, in.	$P_{0a}$	Static Equivalent Thrust (Axial) Load	N, lbf
$d_m$	Mean Bearing Diameter	mm, in.	$P_{0r}$	Static Equivalent Radial Load	N, lbf
$d_s$	Shaft inside diameter	mm, in.	$P_r$	Dynamic Equivalent Radial Load	N, lbf
$D$	Bearing outside diameter	mm, in.	$Q$	Generated Heat or Heat Dissipation Rate	W, BTU/min
$D_0$	Mean outer race diameter	mm, in.	$T$	Torque	N-m, lb-in.
$D_H$	Housing outside diameter	mm, in.	$v$	Vertical (used as subscript)	
$D_m$	Mean Diameter or Effective Working Diameter of a Sprocket, Pulley, Wheel or Tire Also, Tapered Roller Mean Large Rib Diameter	mm, in.	$V$	Linear Velocity or Speed	km/h, mph
$D_{mG}$	Mean or Effective Working Diameter of the Gear	mm, in.	$V_r$	Rubbing, Surface or Tapered Roller Bearing Rib Velocity	m/s, fpm
$D_{mP}$	Effective Working Diameter of the Pinion	mm, in.	$X$	Dynamic Radial Load Factor	
$D_{mW}$	Effective Working Diameter of the Worm	mm, in.	$X_0$	Static Radial Load Factor	
$D_{pG}$	Pitch Diameter of the Gear	mm, in.	$Y$	Dynamic Thrust (Axial) Load Factor	
$D_{pP}$	Pitch Diameter of the Pinion	mm, in.	$Y_0$	Static Thrust (Axial) Load Factor	
$D_{pW}$	Pitch Diameter of the Worm	mm, in.	$Y_G$	Bevel Gearing – Gear Pitch Angle	deg.
$e$	Life Exponent			Hypoid Gearing – Gear Root Angle	deg.
$f$	Lubricant Flow Rate	L/min, U.S. pt/min	$Y_P$	Bevel Gearing – Pinion Pitch Angle	deg.
$f_0$	Viscous Dependent Torque Coefficient			Hypoid Gearing – Pinion Face Angle	deg.
$f_1$	Load Dependent Torque Coefficient		$\alpha$	Coefficient of linear expansion	mm/mm/°C, in./in./°F
$f_B$	Belt or Chain Pull Factor		$\delta_S$	Interference fit of inner race on shaft	mm, in.
$F$	General Term for Force	N, lbf	$\delta_H$	Interference fit of outer race in housing	mm, in.
$F_a$	Applied Thrust (Axial) Load	N, lbf	$\eta$	Efficiency, Decimal Fraction	
$F_{ai}$	Induced Thrust (Axial) Load due to Radial Loading	N, lbf	$\theta_1, \theta_2, \theta_3$	Gear Mesh Angles Relative to the Reference Plane	deg.
$F_{ac}$	Induced Thrust (Axial) Load due to Centrifugal Loading	N, lbf	$\theta_i, \theta_o$	Oil inlet or outlet temperature	°C, °F
$F_{aG}$	Thrust Force on Gear	N, lbf	$\lambda$	Worm Gear Lead Angle	deg.
$F_{aP}$	Thrust Force on Pinion	N, lbf	$\mu$	Coefficient of Friction	
$F_{aW}$	Thrust Force on Worm	N, lbf	$\nu$	Lubricant Kinematic Viscosity	cSt
$f_B$	Belt or Chain Pull	N, lbf	$\sigma_0$	Approximate Maximum Contact Stress	MPa, psi
$F_c$	Centrifugal Force	N, lbf	$\Phi_G$	Normal Tooth Pressure Angle for the Gear	deg.
$F_r$	Applied Radial Load	N, lbf	$\Phi_P$	Normal Tooth Pressure Angle for the Pinion	deg.
$F_{sG}$	Separating Force on Gear	N, lbf	$\psi_G$	Helix (Helical) or Spiral Angle for the Gear	deg.
$F_{sP}$	Separating Force on Pinion	N, lbf	$\psi_P$	Helix (Helical) or Spiral Angle for the Pinion	deg.
$F_{sW}$	Separating Force on Worm	N, lbf	$\Delta T$	Temperature difference between shaft/inner race + rollers and housing/bearing outer race	°C, °F
$F_{te}$	Tractive Effort on Vehicle Wheels	N, lbf	$\rho$	Lubricant Density	kg/m <sup>3</sup> , lb/ft <sup>3</sup>
$F_{tG}$	Tangential Force on Gear	N, lbf			
$F_{tP}$	Tangential Force on Pinion	N, lbf			
$F_{tW}$	Tangential Force on Worm	N, lbf			
$F_W$	Force of Unbalance	N, lbf			
$h$	Horizontal (used as subscript)				
$H$	Power (kW or HP)	kW, HP			
$H_{fS}$	Static Load Rating Adjustment Factor for Raceway Hardness				



DETERMINATION OF APPLIED LOADS

The following equations are used to determine the forces developed by machine elements commonly encountered in bearing applications.

GEARING

Spur gearing (Fig. A-1)

Tangential force

$$F_{tG} = \frac{(1.91 \times 10^7) H}{D_p n_G} \text{ (newtons)}$$

$$= \frac{(1.26 \times 10^5) H}{D_p n_G} \text{ (lbf-in.)}$$

Separating force

$$F_{sG} = F_{tG} \tan \phi_G$$

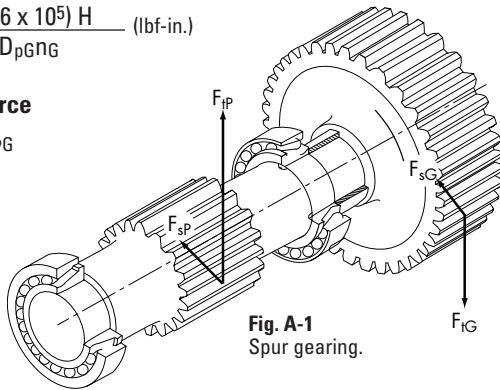

Single helical gearing (Fig. A-2)

Tangential force

$$F_{tG} = \frac{(1.91 \times 10^7) H}{D_p n_G} \text{ (newtons)}$$

$$= \frac{(1.26 \times 10^5) H}{D_p n_G} \text{ (lbf-in.)}$$

Separating force

$$F_{sG} = \frac{F_{tG} \tan \phi_G}{\cos \psi_G}$$

Thrust force

$$F_{aG} = F_{tG} \tan \psi_G$$

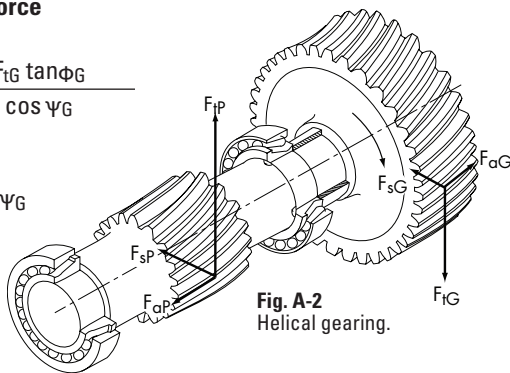

Straight bevel and zero gearing with zero degrees spiral (Fig. A-3)

In straight bevel and zero gearing, the gear forces tend to push the pinion and gear out of mesh, such that the direction of the thrust and separating forces are always the same regardless of direction of rotation. (Fig. A-3) In calculating the tangential force, (FtP or FtG), for bevel gearing, the pinion or gear mean diameter, (DmP or DmG), is used instead of the pitch diameter, (DpP or DpG). The mean diameter is calculated as follows:

$$D_{mG} = D_{pG} - b \sin \gamma_G \quad \text{or} \quad D_{mP} = D_{pP} - b \sin \gamma_P$$

In straight bevel and zero gearing

$$F_{tP} = F_{tG}$$

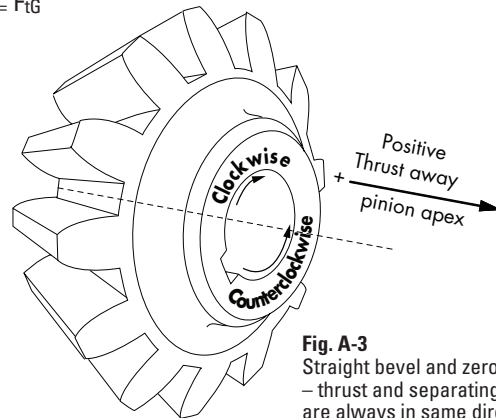

Pinion

Tangential force

$$F_{tP} = \frac{(1.91 \times 10^7) H}{D_{mP} n_P} \text{ (newtons)}$$

$$= \frac{(1.26 \times 10^5) H}{D_{mP} n_P} \text{ (lbf-in.)}$$

Thrust force

$$F_{\phi P} = F_{tP} \tan \phi_P \sin \gamma_P$$

Separating force

$$F_{sP} = F_{tP} \tan \phi_P \cos \gamma_P$$

DETERMINATION OF APPLIED LOADS AND BEARING ANALYSIS - continued

**Straight bevel gear (Fig. A-4)**

**Tangential force**

$$F_{tG} = \frac{(1.91 \times 10^7) H}{D_{mG} n_G} \text{ (newtons)}$$

$$= \frac{(1.26 \times 10^5) H}{D_{mG} n_G} \text{ (lbf-in.)}$$

**Thrust force**

$$F_{aG} = F_{tG} \tan \phi_G \sin \gamma_G$$

**Separating force**

$$F_{sG} = F_{tG} \tan \phi_G \cos \gamma_G$$

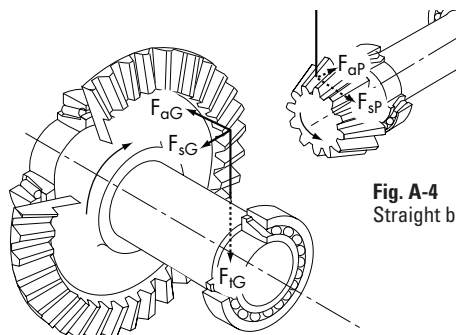

Fig. A-4 Straight bevel gearing.

**Spiral bevel and hypoid gearing (Fig. A-5)**

In spiral bevel and hypoid gearing, the direction of the thrust and separating forces depends upon spiral angle, hand of spiral, direction of rotation, and whether the gear is driving or driven (see Table 1). The hand of the spiral is determined by noting whether the tooth curvature on the near face of the gear (Fig. A-5) inclines to the left or right from the shaft axis. Direction of rotation is determined by viewing toward the gear or pinion apex.

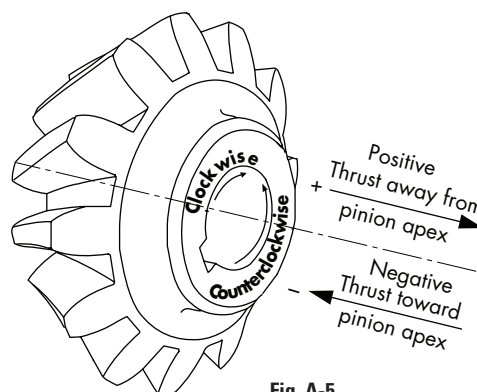

Fig. A-5 Spiral bevel and hypoid gears – the direction of thrust and separating forces depends upon spiral angle, hand of spiral, direction of rotation, and whether the gear is driving or driven.

In spiral bevel gearing

$$F_{tP} = F_{tG}$$

In hypoid gearing

$$F_{tP} = \frac{F_{tG} \cos \psi_P}{\cos \psi_G}$$

Hypoid pinion effective working diameter

$$D_{mP} = D_{mG} \left( \frac{N_P}{N_G} \right) \left( \frac{\cos \psi_G}{\cos \psi_P} \right)$$

**Tangential force**

$$F_{tG} = \frac{(1.91 \times 10^7) H}{D_{mG} n_G} \text{ (newtons)}$$

$$= \frac{(1.26 \times 10^5) H}{D_{mG} n_G} \text{ (lbf-in.)}$$

Hypoid gear effective working diameter

$$D_{mG} = D_{pG} - b \sin \gamma_G$$

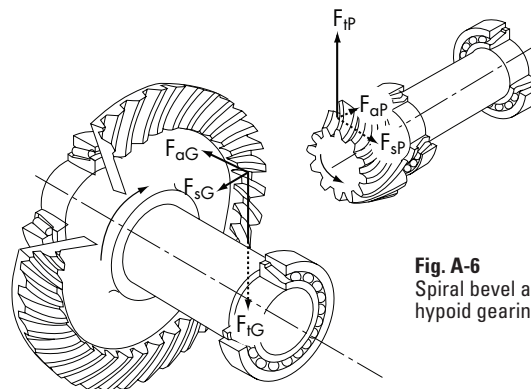

Fig. A-6 Spiral bevel and hypoid gearing.

DETERMINATION OF APPLIED LOADS AND BEARING ANALYSIS - *continued*

TABLE 1

SPIRAL BEVEL AND HYPOID GEARING EQUATIONS

Driving member rotation	Thrust force	Separating force
Right hand spiral clockwise or Left hand spiral counterclockwise	Driving member $F_{aP} = \frac{F_{tP}}{\cos \psi_P} (\tan \phi_P \sin \gamma_P - \sin \psi_P \cos \gamma_P)$	Driving member $F_{sP} = \frac{F_{tP}}{\cos \psi_P} (\tan \phi_P \cos \gamma_P + \sin \psi_P \sin \gamma_P)$
	Driven member $F_{aG} = \frac{F_{tG}}{\cos \psi_G} (\tan \phi_G \sin \gamma_G + \sin \psi_G \cos \gamma_G)$	Driven member $F_{sG} = \frac{F_{tG}}{\cos \psi_G} (\tan \phi_G \cos \gamma_G - \sin \psi_G \sin \gamma_G)$
Right hand spiral counterclockwise or Left hand spiral clockwise	Driving member $F_{aP} = \frac{F_{tP}}{\cos \psi_P} (\tan \phi_P \sin \gamma_P + \sin \psi_P \cos \gamma_P)$	Driving member $F_{sP} = \frac{F_{tP}}{\cos \psi_P} (\tan \phi_P \cos \gamma_P - \sin \psi_P \sin \gamma_P)$
	Driven member $F_{aG} = \frac{F_{tG}}{\cos \psi_G} (\tan \phi_G \sin \gamma_G - \sin \psi_G \cos \gamma_G)$	Driven member $F_{sG} = \frac{F_{tG}}{\cos \psi_G} (\tan \phi_G \cos \gamma_G + \sin \psi_G \sin \gamma_G)$

Straight worm gearing (Fig. A-7)

WORM

Tangential force

$$F_{tW} = \frac{(1.91 \times 10^7) H}{D_{pW} n_W} \text{ (newtons)}$$

$$= \frac{(1.26 \times 10^5) H}{D_{pW} n_W} \text{ (lbf-in.)}$$

Thrust force

$$F_{aW} = \frac{(1.91 \times 10^7) H \eta}{D_{pG} n_G} \text{ (newtons)}$$

$$= \frac{(1.26 \times 10^5) H \eta}{D_{pG} n_G} \text{ (lbf-in.)}$$

or

$$F_{aW} = \frac{F_{tW} \eta}{\tan \lambda}$$

Separating force

$$F_{sW} = \frac{F_{tW} \sin \Phi}{\cos \Phi \sin \lambda + \mu \cos \lambda}$$

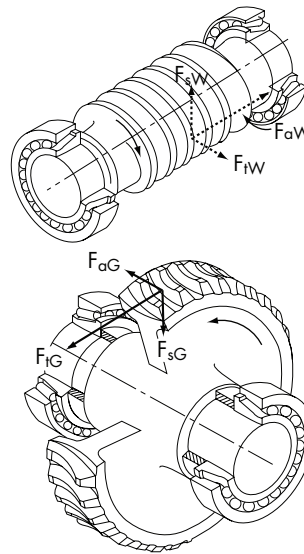

Fig. A-7  
Straight worm gearing.



## DETERMINATION OF APPLIED LOADS AND BEARING ANALYSIS - continued

## Worm Gear

## Tangential force

$$F_{tG} = \frac{(1.91 \times 10^7) H \eta}{D_{pG} n_G} \quad (\text{newtons})$$

$$= \frac{(1.26 \times 10^5) H \eta}{D_{pG} n_G} \quad (\text{lbf-in.})$$

or

$$F_{tG} = \frac{F_{tW} \eta}{\tan \lambda}$$

## Thrust force

$$F_{aG} = \frac{(1.91 \times 10^7) H}{D_{pW} n_W} \quad (\text{newtons})$$

$$= \frac{(1.26 \times 10^5) H}{D_{pW} n_W} \quad (\text{lbf-in.})$$

## Separating force

$$F_{sG} = \frac{F_{tW} \sin \Phi}{\cos \Phi \sin \lambda + \mu \cos \lambda}$$

where:

$$\lambda = \tan^{-1} \left( \frac{D_{pG}}{m D_{pW}} \right) = \tan^{-1} \left( \frac{L}{\pi D_{pW}} \right)$$

$$\eta = \frac{\cos \Phi - \mu \tan \lambda}{\cos \Phi + \mu \cot \lambda}$$

## Metric system

$$\mu^* = (5.34 \times 10^{-7}) V_r^3 + \frac{0.146}{V_r^{0.09}} - 0.103$$

$$V_r = \frac{D_{pW} n_W}{(1.91 \times 10^4) \cos \lambda} \quad (\text{meters per second})$$

## Inch system

$$\mu^* = (7 \times 10^{-14}) V_r^3 + \frac{0.235}{V_r^{0.09}} - 0.103$$

$$V_r = \frac{D_{pW} n_W}{3.82 \cos \lambda} \quad (\text{feet per minute})$$

\*Approximate coefficient of friction for the 0.015 to 15 m/s (3 to 3000 ft/min) rubbing velocity range.

## Double enveloping worm gearing

## Worm

## Tangential force

$$F_{tW} = \frac{(1.91 \times 10^7) H}{D_{mW} n_W} \quad (\text{newtons})$$

$$= \frac{(1.26 \times 10^5) H}{D_{mW} n_W} \quad (\text{lbf-in.})$$

## Thrust force

$$F_{aW} = 0.98 F_{tG}$$

Use this value for calculating torque in subsequent gears and shafts. For bearing loading calculations, use the equation for  $F_{aW}$ .

## Separating force

$$F_{sW} = \frac{0.98 F_{tG} \tan \Phi}{\cos \lambda}$$

## WORM GEAR

## Tangential force

$$F_{tG} = \frac{(1.91 \times 10^7) H m \eta}{D_{pG} n_W} \quad (\text{newtons})$$

$$= \frac{(1.26 \times 10^5) H m \eta}{D_{pG} n_W} \quad (\text{lbf-in.})$$

or

$$F_{tG} = \frac{(1.91 \times 10^7) H \eta}{D_{pG} n_G} \quad (\text{newtons})$$

$$= \frac{(1.26 \times 10^5) H \eta}{D_{pG} n_G} \quad (\text{lbf-in.})$$

Use this value for  $F_{tG}$  for bearing loading calculations on worm gear shaft. For torque calculations, use the following  $F_{tG}$  equations.

## Thrust force

$$F_{aG} = \frac{(1.91 \times 10^7) H}{D_{mW} n_W} \quad (\text{newtons})$$

$$= \frac{(1.26 \times 10^5) H}{D_{mW} n_W} \quad (\text{lbf-in.})$$

## Separating force

$$F_{sG} = \frac{0.98 F_{tG} \tan \Phi}{\cos \lambda}$$

where:

$\eta$  = efficiency (refer to manufacturer's catalog)

$$D_{mW} = 2d_c - 0.98 D_{pG}$$

Lead angle at center of worm

$$\lambda = \tan^{-1} \left( \frac{D_{pG}}{m D_{pW}} \right) = \tan^{-1} \left( \frac{L}{\pi D_{pW}} \right)$$

DETERMINATION OF APPLIED LOADS AND BEARING ANALYSIS - continued

**Belt and chain drive factors (Fig. A-8)**

Due to the variations of belt tightness as set by various operators, an exact equation relating total belt pull to tension F1 on the tight side and tension F2 on the slack side (Fig. A-8) is difficult to establish. The following equation and Table 2 may be used to estimate the total pull from various types of belt and pulley, and chain and sprocket designs:

$$F_b = \frac{(1.91 \times 10^7) H f_B}{D_m n} \quad (\text{newtons})$$

$$= \frac{(1.26 \times 10^5) H f_B}{D_m n} \quad (\text{lbf-in.})$$

Standard roller chain sprocket mean diameter

$$D_m = \frac{P}{\sin\left(\frac{180}{N_s}\right)}$$

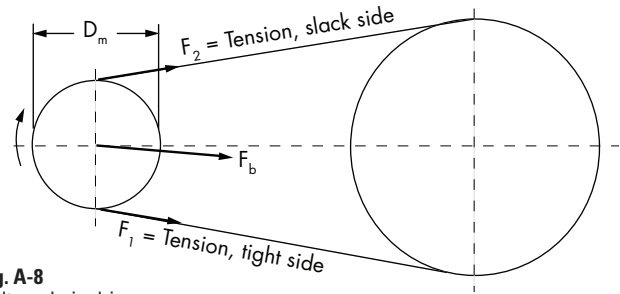

**Fig. A-8**  
Belt or chain drive.

Type	f <sub>B</sub>
Chains, single .....	1.00
Chains, double .....	1.25
"V" belts.....	1.50

**Table 2**  
Belt or chain pull factor based on 180 degrees angle of wrap.

**CENTRIFUGAL FORCE**

Centrifugal force resulting from imbalance in a rotating member:

$$F_c = \frac{F_w r n^2}{8.94 \times 10^5} \quad (\text{newtons})$$

$$= \frac{F_w r n^2}{3.52 \times 10^4} \quad (\text{lbf-in.})$$

**SHOCK LOADS**

It is difficult to determine the exact effect that shock loading has on bearing life. The magnitude of the shock load depends on the masses of the colliding bodies, their velocities, and deformations at impact.

The effect on the bearing depends on how much of the shock is absorbed between the point of impact and the bearings, as well as whether the shock load is great enough to cause bearing damage. It also is dependent on frequency and duration of shock loads.

At a minimum, a suddenly applied load is equivalent to twice its static value. It may be considerably more than this, depending on the velocity of impact.

Shock involves a number of variables that generally are not known or easily determined. Therefore, it is good practice to rely on experience. The Timken Company has years of experience with many types of equipment under the most severe loading conditions. Your Timken representative should be consulted on any application involving unusual loading or service requirements.

**GENERAL FORMULAS**

**Tractive effort and wheel speed**

The relationships of tractive effort, power, wheel speed and vehicle speed are:

**Metric system**

$$H = \frac{F_{te} V}{3600} \quad (\text{kW})$$

$$n = \frac{5300 V}{D_m} \quad (\text{rev/min})$$

**Inch system**

$$H = \frac{F_{te} V}{375} \quad (\text{HP})$$

$$n = \frac{336 V}{D_m} \quad (\text{rev/min})$$

**Torque to power relationship**

**Metric system**

$$T = \frac{60\,000 H}{2\pi n} \quad (\text{N-m})$$

$$H = \frac{2\pi n T}{60\,000} \quad (\text{kW})$$

**Inch system**

$$T = \frac{395\,877 H}{2\pi n} \quad (\text{lbf-in.})$$

$$H = \frac{2\pi n T}{395\,877} \quad (\text{HP})$$

# BEARING REACTIONS, DYNAMIC EQUIVALENT LOADS & BEARING LIFE

## BEARING REACTIONS

Equations and procedure for determining bearing reactions follow.

### Effective spread

When a load is applied to a tapered roller or angular contact ball bearing, the internal forces at each rolling element to outer raceway contact act normal to the raceway. These forces have radial and axial components. With the exception of the special case of pure thrust loads, the inner ring and the shaft will experience moments imposed by the asymmetrical axial components of the forces on the rollers.

It can be demonstrated mathematically that, if the shaft is modeled as being supported at its effective bearing center rather than at its geometric bearing center, the bearing moment may be ignored when calculating radial loads on the bearing. Only externally applied loads need to be considered, and moments are taken about the effective centers of the bearings to determine bearing loads or reactions. Fig. A-9 shows single-row bearings in a direct and indirect mounting configuration. The choice of whether to use direct or indirect mounting depends upon the application and duty.

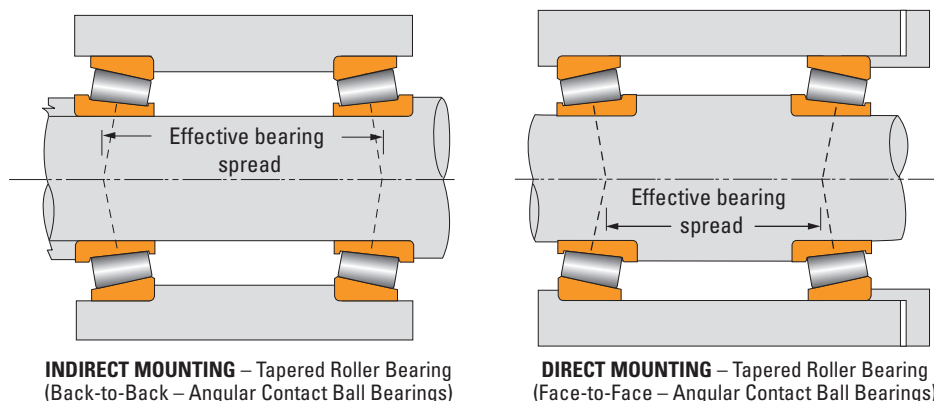

**Fig. A-9**  
Choice of mounting configuration for single-row bearings,  
showing position of effective load carrying centers.

### Shaft on two supports

Simple beam equations are used to translate the externally applied forces on a shaft into bearing reactions acting at the bearing effective centers.

With two-row tapered and angular contact ball bearings, the geometric center of the bearing is considered to be the support point except where the thrust force is large enough to unload one row. Then, the effective center of the loaded row is used as the point from which bearing load reactions are calculated. These approaches approximate the load distribution within a two-row bearing, assuming rigid shaft and housing. These are statically indeterminate problems in which shaft and support rigidity can significantly influence bearing loading and require the use of computer programs to solve.

### Shaft on three or more supports

The equations of static equilibrium are insufficient to solve bearing reactions on a shaft having more than two supports. Such cases can be solved using computer programs if adequate information is available.

In such problems, the deflections of the shaft, bearings and housings affect the distribution of loads. Any variance in these parameters can significantly affect bearing reactions.

BEARING REACTIONS, DYNAMIC EQUIVALENT LOADS & BEARING LIFE - *continued*

CALCULATION EQUATIONS

Symbols Used		
$a_e$	Effective bearing spread	mm, in.
A, B, ...	Bearing position, used as subscripts	
$c_1, c_2, \dots$	Linear distance (positive or negative)	mm, in.
$D_{pG}$	Pitch diameter of the gear	mm, in.
F	Applied force	N, lbf
$F_r$	Radial bearing load	N, lbf
h	Horizontal (used as subscript)	
M	Moment	N-mm, lbf-in.
v	Vertical (used as subscript)	
$\theta_1$	Gear mesh angle relative to plane of reference defined in Figure A-10	degree
$\theta_2$	Angle of applied force relative to plane of reference defined in Figure A-10	degree
$\theta_3$	Angle of applied moment relative to plane of reference defined in Figure A-10	degree

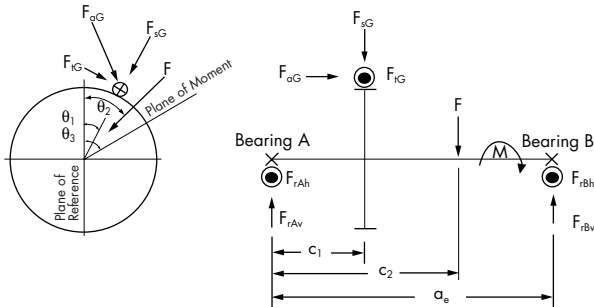

Fig. A-10  
Bearing radial reactions.

Bearing radial loads are determined by:

1. Resolving forces applied to the shaft into horizontal and vertical components, relative to a convenient reference plane.
2. Taking moments about the opposite support.
3. Combining the horizontal and vertical reactions at each support into one resultant load.

Shown are equations for the case of a shaft on two supports with gear forces  $F_t$  (tangential),  $F_s$  (separating), and  $F_a$  (thrust), an external radial load  $F$ , and an external moment  $M$ . The loads are applied at arbitrary angles ( $\theta_1$ ,  $\theta_2$ , and  $\theta_3$ ) relative to the reference plane indicated in Fig. A-10. Using the principle of superposition, the equations for vertical and horizontal reactions ( $F_{rv}$  and  $F_{rh}$ ) can be expanded to include any number of gears, external forces or moments. Use signs as determined from gear force equation.

Care should be used when doing this to ensure proper supporting degrees of freedom are used. That is, tapered roller bearings and ball bearings support radial loads, moment loads and thrust loads in both directions. Spherical roller bearings will not support a moment load, but will support radial and thrust loads in both directions. Cylindrical roller bearings support radial and moment loading, but can only support slight thrust loads depending upon thrust flange configuration. Finally, needle roller bearings only support radial and moment loading.

Vertical reaction component at bearing position B

$$F_{rBv} = \frac{1}{a_e} \left[ c_1 (F_{sG} \cos \theta_1 + F_{tG} \sin \theta_1) + \frac{1}{2} (D_{pG} - b \sin \gamma_G) F_{aG} \cos \theta_1 + c_2 F \cos \theta_2 + M \cos \theta_3 \right]$$

Horizontal reaction component at bearing position B

$$F_{rBh} = \frac{1}{a_e} \left[ c_1 (F_{sG} \sin \theta_1 - F_{tG} \cos \theta_1) + \frac{1}{2} (D_{pG} - b \sin \gamma_G) F_{aG} \sin \theta_1 + c_2 F \sin \theta_2 + M \sin \theta_3 \right]$$

Vertical reaction component at bearing position A

$$F_{rAv} = F_{sG} \cos \theta_1 + F_{tG} \sin \theta_1 + F \cos \theta_2 - F_{rBv}$$

Horizontal reaction component at bearing position A

$$F_{rAh} = F_{sG} \sin \theta_1 - F_{tG} \cos \theta_1 + F \sin \theta_2 - F_{rBh}$$

Resultant radial reaction

$$F_{rA} = (F_{rAv}^2 + F_{rAh}^2)^{1/2}$$

$$F_{rB} = (F_{rBv}^2 + F_{rBh}^2)^{1/2}$$

**BEARING REACTIONS, DYNAMIC EQUIVALENT LOADS & BEARING LIFE - continued****Equivalent dynamic radial bearing loads ( $P_r$ )**

To calculate the  $L_{10}$  life, it is necessary to calculate a dynamic equivalent radial load, designated by  $P_r$ . The dynamic equivalent radial load is defined as a single radial load that, if applied to the bearing, will result in the same life as the combined loading under which the bearing operates.

$$P_r = XF_r + Y_1F_a$$

Where,

$P_r$  = Dynamic Equivalent Radial Load

$F_r$  = Applied Radial Load

$F_a$  = Applied Axial Load

$X$  = Radial Load Factor

$Y$  = Axial Load Factor

For spherical roller bearings, the values for  $X$  and  $Y$  can be determined using the equations below. Calculate the ratio of the axial load to the radial load. Compare this ratio to the  $e$  value for the bearing.

In equation form,

$$P_r = F_r + Y_2 F_a \quad \text{for } F_a/F_r \leq e, \text{ and}$$

$$P_r = 0.67F_r + Y_2 F_a \quad \text{for } F_a/F_r > e.$$

Note that values for  $e$ ,  $Y_1$  and  $Y_2$  are available in the bearing tables.

Needle roller bearings are designed to carry radial load with zero thrust load under normal conditions. With the thrust load equal to zero equivalent radial load ( $P_r$ ) is equal to the design radial load ( $F_r$ ). Your Timken representative should be consulted on any applications where thrust load is involved, as the resulting increase in internal friction may require cooling to prevent increased operating temperatures.

For cylindrical roller bearings with purely radial applied load:

$$P = F_r \text{ (kN)}$$

Note: The maximum dynamic radial load that may be applied to a cylindrical roller bearing should be  $\leq C/3$ .

If, in addition to the radial load, an axial load  $F_a$  acts on the bearing, this axial load is taken into consideration when calculating the life of a bearing (with  $F_a \leq F_{az}$ ;  $F_{az}$  is the allowable axial load).

Dimension Series	Load ratio	Equivalent Dynamic Load
10.. 2..E, 3..E	$F_a/F_r \leq 0.11$	$P = F_r$
	$F_a/F_r > 0.11$	$P = 0.93 \cdot F_r + 0.69 \cdot F_a$
22..E, 23..E	$F_a/F_r \leq 0.17$	$P = F_r$
	$F_a/F_r > 0.17$	$P = 0.93 \cdot F_r + 0.45 \cdot F_a$

Tapered roller bearings use the equations based on the number of rows and type of mounting utilized. For single-row bearings in direct or indirect mounting, the table on page A31 can be used based on the direction of the externally applied thrust load. Once the appropriate design is chosen, review the table and check the thrust condition to determine which thrust load and dynamic equivalent radial load calculations apply.

BEARING REACTIONS, DYNAMIC EQUIVALENT LOADS & BEARING LIFE - *continued*

For ball bearings, the dynamic equivalent radial load can be found in Table 3. The required Y factors are found in the Table 4.

TABLE 3

Bearing Description (ref.)	Contact Angle	Single-Row and Tandem Mountings	Double-Row and Preload Pair Mountings
<b>Bearing Type and or Series</b>		$KT = \frac{F_a}{(\# \text{ of bearings}) \times C_0}$	$KT = \frac{F_a}{C_0}$
<b>RADIAL TYPE BALL BEARINGS Use larger of Resulting "P" Value*</b>			
M9300K,MM9300K M9100K,MM9100K M200K,MM200K M300K,MM300K	0°	P = F <sub>r</sub> or P = 0.56F <sub>r</sub> + Y <sub>1</sub> F <sub>a</sub>	P = F <sub>r</sub> + 1.20Y <sub>1</sub> F <sub>a</sub> or P = 0.78F <sub>r</sub> + 1.625Y <sub>1</sub> F <sub>a</sub>
Small inch and Metric 9300,9100,200,300 and derivatives XLS Large Inch W and GW Tri-Ply	0°	P = F <sub>r</sub> or P = 0.56F <sub>r</sub> + Y <sub>1</sub> F <sub>a</sub>	
WIDE INNER RING BALL BEARINGS HOUSED UNITS	0°	P = F <sub>r</sub> or P = 0.56F <sub>r</sub> + Y <sub>1</sub> F <sub>a</sub>	
<b>ANGULAR CONTACT BALL BEARINGS Use larger of Resulting "P" Value</b>			
7200K, 7200W 7300W, 7400W 5200K-5300W 5311W-5318W 5218W, 5220W, 5407W 5221W, 5214W	20°	P = F <sub>r</sub> or P = 0.43F <sub>r</sub> + F <sub>a</sub>	P = F <sub>r</sub> + 1.09F <sub>a</sub> or P = 0.70F <sub>r</sub> + 1.63F <sub>a</sub>
5200, 5200W (see 20° exceptions) 5300, 5300W (see 20° exceptions) 5400, 5400W (see 20° exceptions)	30°	P = F <sub>r</sub> or P = 0.39F <sub>r</sub> + 0.76F <sub>a</sub>	P = F <sub>r</sub> + 0.78F <sub>a</sub> or P = 0.63F <sub>r</sub> + 1.24F <sub>a</sub>
7200WN 7300WN 7400WN	40°	P = F <sub>r</sub> or P = 0.35F <sub>r</sub> + 0.57F <sub>a</sub>	P = F <sub>r</sub> + 0.55F <sub>a</sub> or P = 0.57F <sub>r</sub> + 0.93F <sub>a</sub>
2M9300WI 2M9100WI,2MM9100WI 2M200WI, 2MM9100WI 2MM300WI	15°	P = F <sub>r</sub> or P = 0.44F <sub>r</sub> + Y <sub>2</sub> F <sub>a</sub>	P = F <sub>r</sub> + 1.124Y <sub>2</sub> F <sub>a</sub> or P = 0.72F <sub>r</sub> + 1.625Y <sub>2</sub> F <sub>a</sub>
2MM9100WO		P = F <sub>r</sub> or P = 0.44F <sub>r</sub> + Y <sub>3</sub> F <sub>a</sub>	P = F <sub>r</sub> + 1.124Y <sub>3</sub> F <sub>a</sub> or P = 0.72F <sub>r</sub> + 1.625Y <sub>3</sub> F <sub>a</sub>
3M9300WI 3M9100WI,3MM9100WI 3M200WI, 3MM200WI 3MM300WI	25°	P = F <sub>r</sub> or P = 0.41F <sub>r</sub> + 0.87F <sub>a</sub>	P = F <sub>r</sub> + 0.92F <sub>a</sub> or P = 0.67F <sub>r</sub> + 1.41F <sub>a</sub>

\* Note: If P > C<sub>0</sub> or P > 1/2 C<sub>E</sub> consult with your Timken representative on Life Calculations.

TABLE 4

K <sub>T</sub>	Y <sub>1</sub>	Y <sub>2</sub>	Y <sub>3</sub>
0.015	2.30	1.47	1.60
0.020	2.22	1.44	1.59
0.025	2.10	1.41	1.57
0.030	2.00	1.39	1.56
0.040	1.86	1.35	1.55
0.050	1.76	1.32	1.53
0.060	1.68	1.29	1.51
0.080	1.57	1.25	1.49
0.100	1.48	1.21	1.47
0.120	1.42	1.19	1.45
0.150	1.34	1.14	1.42
0.200	1.25	1.09	1.39
0.250	1.18	1.05	1.35
0.300	1.13	1.02	1.33
0.400	1.05	1.00	1.29
0.500	1.00	1.00	1.25
0.600	—	—	1.22
0.800	—	—	1.17
1.000	—	—	1.13
1.200	—	—	1.10

Equivalent Dynamic Thrust Bearing Loads (P<sub>a</sub>)

For thrust ball, cylindrical and tapered roller bearings, the existence of radial loads introduces complex load calculations that must be carefully considered. If radial load is zero, the equivalent dynamic thrust load (P<sub>a</sub>) will be equal to the applied thrust load (F<sub>a</sub>). If any radial load is expected in the application, consult your Timken representative for advice on bearing selection.

For thrust angular contact ball bearings, the equivalent dynamic thrust load is determined by:

$$P_a = X_r F_r + Y F_a$$

The minimum permissible thrust load to radial load ratios (F<sub>a</sub>/F<sub>r</sub>) and X and Y factors are listed in the bearing dimension tables in the thrust bearing section.

Thrust spherical roller bearing dynamic thrust loads are determined by:

$$P_a = 1.2F_r + F_a$$

Radial load (F<sub>r</sub>) of a thrust spherical roller bearing is proportional to the applied axial load (F<sub>a</sub>) with F<sub>r</sub> ≤ 0.55 F<sub>a</sub>. Because of the steep roller angle and the fact that the bearing is separable, a radial load will induce a thrust component (F<sub>ai</sub> = 1.2 F<sub>r</sub>), that must be resisted by another thrust bearing on the shaft or by an axial load greater than F<sub>ai</sub>.



BEARING REACTIONS, DYNAMIC EQUIVALENT LOADS & BEARING LIFE - continued

**BEARING EQUIVALENT LOADS AND REQUIRED RATINGS FOR TAPERED ROLLER BEARINGS**

Tapered roller bearings are ideally suited to carry all types of loadings - radial, thrust, and any combination of both. Due to the tapered design of the bearing, a radial load will induce a thrust reaction within the bearing which must be opposed by an equal or greater thrust load in order to keep the bearing cone and cup from separating. The ratio of the radial to the thrust load and the bearing included cup angle determine the load zone in a given bearing. The number of rollers in contact as a result of this ratio determines the load zone in the bearing. If all the rollers are in contact, the load zone is referred to as being 360 degrees.

When only radial load is applied to a tapered roller bearing, for convenience it is assumed in using the traditional calculation method that half the rollers support the load – the load zone is 180 degrees. In this case, induced bearing thrust is:

$$F_{a(180)} = \frac{0.47 F_r}{K}$$

The equations for determining bearing thrust reactions and equivalent radial loads in a system of two single-row bearings are based on the assumption of a 180-degree load zone in one of the bearings and 180 degrees or more in the opposite bearing.

**Dynamic Equivalent Radial Load**

The basic dynamic radial load rating,  $C_{90}$ , is assumed to be the radial load carrying capacity with a 180-degree load zone in the bearing. When the thrust load on a bearing exceeds the induced thrust,  $F_{a(180)}$ , a dynamic equivalent radial load must be used to calculate bearing life.

The dynamic equivalent radial load is that radial load which, if applied to a bearing, will give the same life as the bearing will attain under the actual loading.

The equations presented give close approximations of the dynamic equivalent radial load assuming a 180-degree load zone in one bearing and 180 degrees or more in the opposite bearing.

Tapered roller bearings use the equations based on the number of rows and type of mounting utilized. For single-row bearings in direct or indirect mounting, the following table can be used based on the direction of the externally applied thrust load. Once the appropriate design is chosen, review the table and check the thrust condition to determine which thrust load and dynamic equivalent radial load calculations apply.

**SINGLE-ROW MOUNTING**

To use this table for a single-row mounting, determine if bearings are direct or indirect mounted and to which bearing, A or B, thrust  $F_{ae}$  is applied. Once the appropriate design is established, follow across the page opposite that design, and check to determine which thrust load and dynamic equivalent radial load equations apply.

Design	Thrust Condition	Thrust Load	Dynamic Equivalent Radial Load
	$\frac{0.47 F_{rA}}{K_A} \leq \left( \frac{0.47 F_{rB}}{K_B} + F_{ae} \right)$	$F_{aA} = \frac{0.47 F_{rB}}{K_B} + F_{ae}$ $F_{aB} = \frac{0.47 F_{rB}}{K_B}$	$*P_A = 0.4 F_{rA} + K_A F_{aA}$ $P_B = F_{rB}$
	$\frac{0.47 F_{rA}}{K_A} > \left( \frac{0.47 F_{rB}}{K_B} + F_{ae} \right)$	$F_{aA} = \frac{0.47 F_{rA}}{K_A}$ $F_{aB} = \frac{0.47 F_{rA}}{K_A} - F_{ae}$	$P_A = F_{rA}$ $*P_B = 0.4 F_{rB} + K_B F_{aB}$
	$\frac{0.47 F_{rB}}{K_B} \leq \left( \frac{0.47 F_{rA}}{K_A} + F_{ae} \right)$	$F_{aA} = \frac{0.47 F_{rA}}{K_A}$ $F_{aB} = \frac{0.47 F_{rA}}{K_A} + F_{ae}$	$P_A = F_{rA}$ $*P_B = 0.4 F_{rB} + K_B F_{aB}$
	$\frac{0.47 F_{rB}}{K_B} > \left( \frac{0.47 F_{rA}}{K_A} + F_{ae} \right)$	$F_{aA} = \frac{0.47 F_{rB}}{K_B} - F_{ae}$ $F_{aB} = \frac{0.47 F_{rB}}{K_B}$	$*P_A = 0.4 F_{rA} + K_A F_{aA}$ $P_B = F_{rB}$

\* If  $P_A < F_{rA}$ , use  $P_A = F_{rA}$  and if  $P_B < F_{rB}$ , use  $P_B = F_{rB}$ .

BEARING REACTIONS, DYNAMIC EQUIVALENT LOADS & BEARING LIFE - continued

**TWO-ROW MOUNTING, FIXED OR FLOATING (WITH NO EXTERNAL THRUST,  $F_{AE} = 0$ ) SIMILAR BEARING SERIES**

For double-row tapered roller bearings, the following table can be used. In this table, only bearing A has an applied thrust load. If bearing B has the applied thrust load, the A's in the equations should be replaced by B's and vice versa.

For two-row similar bearing series with no external thrust,  $F_{ae}=0$ , the dynamic equivalent radial load, P, equals  $F_{rAB}$  or  $F_{rC}$ . Since  $F_{rAB}$  or  $F_{rC}$  is the radial load on the two-row assembly, the two-row basic dynamic radial loads rating,  $C_{90(2)}$ , is to be used to calculate bearing life.

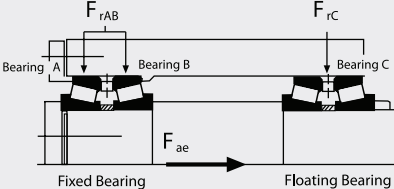
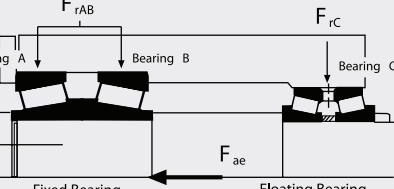
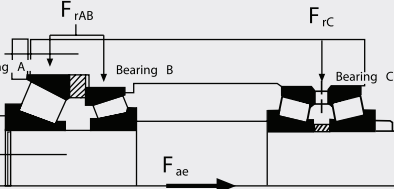
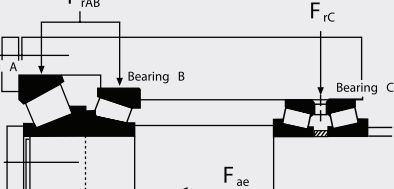
Design	Thrust Condition	Dynamic Equivalent Radial Load
<p><b>SIMILAR BEARING SERIES,</b> <math>K_A = K_B</math></p>  <p>Fixed Bearing      Floating Bearing</p>	$F_{ae} \leq \frac{0.6 F_{rAB}}{K_A}$	$P_A = 0.5 F_{rAB} + 0.83 K_A F_{ae}$ $P_B = 0.5 F_{rAB} - 0.83 K_A F_{ae}$
	 <p>Fixed Bearing      Floating Bearing</p>	$F_{ae} > \frac{0.6 F_{rAB}}{K_A}$
<p><b>DISSIMILAR BEARING SERIES,</b> <math>K_A \neq K_B</math></p>  <p>Fixed Bearing      Floating Bearing</p>	$F_{ae} \leq \frac{0.6 F_{rAB}}{K_A}$	$P_A = \frac{K_A}{K_A + K_B} (F_{rAB} + 1.67 K_B F_{ae})$ $P_B = \frac{K_B}{K_A + K_B} (F_{rAB} - 1.67 K_A F_{ae})$
	 <p>Fixed Bearing      Floating Bearing</p>	$F_{ae} > \frac{0.6 F_{rAB}}{K_A}$

Note:  $F_{rAB}$  is the radial load on the two-row assembly. The single-row basic dynamic radial load rating,  $C_{90}$ , is to be applied when calculating life based on the above equations.





BEARING REACTIONS, DYNAMIC EQUIVALENT LOADS & BEARING LIFE - *continued*

**OPTIONAL APPROACH FOR DETERMINING DYNAMIC EQUIVALENT RADIAL LOADS**

The following is a general approach to determining the dynamic equivalent radial loads. Here, a factor “m” has to be defined as +1 for direct-mounted single-row or two-row bearings or -1 for indirect mounted bearings. Also a sign convention is necessary for the external thrust  $F_{ae}$  as follows:

- a. In case of external thrust applied to the shaft (typical rotating cone application),  $F_{ae}$  to the right is positive; to the left is negative.
- b. When external thrust is applied to the housing (typical rotating cup application)  $F_{ae}$  to the right is negative; to the left is positive.

**1. SINGLE-ROW MOUNTING**

Design	Thrust Condition	Thrust Load	Dynamic Equivalent Radial Load
<p>Indirect Mounting (m=-1)</p>	$\frac{0.47 F_{rA}}{K_A} \leq \frac{0.47 F_{rB}}{K_B} - m F_{ae}$	$F_{aA} = \frac{0.47 F_{rB}}{K_B} - m F_{ae}$ $F_{aB} = \frac{0.47 F_{rB}}{K_B}$	$P_A = 0.4 F_{rA} + K_A F_{aA}$ $P_B = F_{rB}$
<p>Direct Mounting (m=1)</p>	$\frac{0.47 F_{rA}}{K_A} > \frac{0.47 F_{rB}}{K_B} - m F_{ae}$	$F_{aA} = \frac{0.47 F_{rA}}{K_A}$ $F_{aB} = \frac{0.47 F_{rA}}{K_A} + m F_{ae}$	$P_A = F_{rA}$ $P_B = 0.4 F_{rB} + K_B F_{aB}$

Note: If  $P_A < F_{rA}$ , use  $P_A = F_{rA}$  or if  $P_B < F_{rB}$ , use  $P_B = F_{rB}$

**2. TWO-ROW MOUNTING – FIXED BEARING WITH EXTERNAL THRUST,  $F_{ae}$  (SIMILAR OR DISSIMILAR SERIES)**

Design	Thrust Condition	Dynamic Equivalent Radial Load
<p>Fixed Bearing Indirect Mounting (m=-1)</p>	$F_{ae} \leq \frac{0.6 F_{rAB}}{K^*}$	$P_A = \frac{K_A}{K_A + K_B} (F_{rAB} - 1.67 m K_B F_{ae})$ $P_B = \frac{K_B}{K_A + K_B} (F_{rAB} + 1.67 m K_A F_{ae})$
<p>Fixed Bearing Direct Mounting (m=1)</p>	$F_{ae} > \frac{0.6 F_{rAB}}{K^*}$	$P_A = 0.4 F_{rAB} - m K_A F_{ae}$ $P_B = 0.4 F_{rAB} + m K_B F_{ae}$

Note:  $F_{rAB}$  is the radial load on the two-row assembly. The single-row basic dynamic radial load rating,  $C_{90}$ , is to be applied when calculating life based on the above equations.

BEARING REACTIONS, DYNAMIC EQUIVALENT LOADS & BEARING LIFE - continued

When the loading is static, it is usually suggested that the applied load be no greater than the basic static load rating divided by the appropriate factor (HF<sub>s</sub>) as shown in the table below.

Hardness Factors to Modify BASIC STATIC LOAD RATING	
Raceway Hardness HRC	Hardness Factor HF <sub>s</sub>
58	1.00
57	1.06
56	1.13
55	1.21
54	1.29
53	1.37
52	1.46
51	1.55
50	1.65
49	1.76
48	1.88
47	2.00
46	2.13
45	2.27
44	2.41
43	2.57
42	2.74
41	2.92
40	3.10

MINIMUM BEARING LOAD

Slippage can occur if loads are too light and, if accompanied by inadequate lubrication, cause damage to the bearings. The minimum load for radial cylindrical, spherical and full-complement needle roller bearings is P/C = 0.04 (P is the dynamic load and C is the basic dynamic load rating).

Thrust needle roller bearings also have an added design requirement such that the minimum thrust load is satisfied to prevent the rollers from skidding on the raceway. (The equation for the thrust loading force is different for needle rollers versus cylindrical rollers as noted):

(needle rollers)  $F_{a \text{ min}} = C_0 / 2200 \text{ kN}$   
 (cylindrical rollers)  $F_{a \text{ min}} = 0.1 C_0 / 2200 \text{ kN}$

Centrifugal force in thrust spherical roller bearings tends to propel the rollers outward. The bearing geometry converts this force to another induced thrust component which must be overcome by an axial load. This induced thrust (F<sub>ac</sub>) is given by:

$$F_{ac} = kn^2 \times 10^{-5} \text{ (lbf)}$$

The minimum required working thrust load on a thrust spherical roller bearing (F<sub>a min</sub>) is then computed by:

$$F_{a \text{ min}} = 1.2 F_r + F_{ac} \geq \frac{C_{0a}}{1000} \text{ (lbf)}$$

In addition to meeting the above calculated value, the minimum required working thrust load (F<sub>a min</sub>) should be equal to or greater than 0.1 percent of the static thrust load rating (C<sub>0a</sub>).

CYLINDRICAL ROLLER BEARING  
 MAXIMUM ALLOWABLE AXIAL LOAD

Metric series cylindrical roller bearings of NUP, NP, NF, as well as NU or NJ designs with a thrust collar, can transmit axial loads if they are radially loaded at the same time. The allowable axial load ratio F<sub>a</sub>/C of 0.1 maximum depends to a great extent on the magnitude of radial load, the operating speed, type of lubricant used, the operating temperature, and heat transfer conditions at the bearing location. The heat balance achieved at the bearing location is used as a basis for determination of the allowable axial load.

The nomogram on page A35 should be used to determine the allowable axial load F<sub>az</sub> based on the following operating conditions:

- The axial load is of constant direction and magnitude
- Radial load ratio F<sub>r</sub>/C ≤ 0.2
- Ratio of axial load to radial load F<sub>a</sub>/F<sub>r</sub> < 0.4
- The temperature of the bearing is 80° C (176° F) at an ambient temperature of 20° C (68° F).
- Lubricating oil is ISO VG 100 or greater using oil bath lubrication or circulating oil.
- As an alternative, the bearing may be lubricated with a grease using the above specified base oil and viscosity. Use of EP additives will be necessary, although considerably shorter relubrication intervals may be expected than with purely radially loaded radial cylindrical roller bearings.

Example of using the nomogram

From the lower part of the nomogram, determine the intersection point of the inner ring bore diameter and the dimension series of the bearing. From the upper part, the allowable axial load ratio F<sub>az</sub>/C can be found as a function of the operating speed, n.

For a cylindrical roller radial bearing NU2207E.TVP  
 C = 63 kN; d = 35 mm  
 n = 2000 RPM  
 F<sub>r</sub> = 10 kN

From the nomogram:  
 F<sub>az</sub>/C = 0.06  
 Then F<sub>az</sub> = 0.06 • 63  
 The calculated allowable axial load F<sub>az</sub> is 3.78 kN

It should be noted that an axial load as high as that determined by means of the nomogram should not be applied if an oil of rated kinematic viscosity lower than ISO VG 100 is used. Suitable EP additives, which are known for fatigue life improving qualities, may allow for an increase in applied axial load subject to thorough testing.

Higher applied axial loads

Axial loads greater than those determined by means of the nomogram may be considered, providing they are to be applied intermittently. Also, the bearing should be cooled using circulating oil lubrication and if the operating temperature, due to the internal friction and the higher axial load, exceeds 80° C (176° F), a more viscous oil must be used.

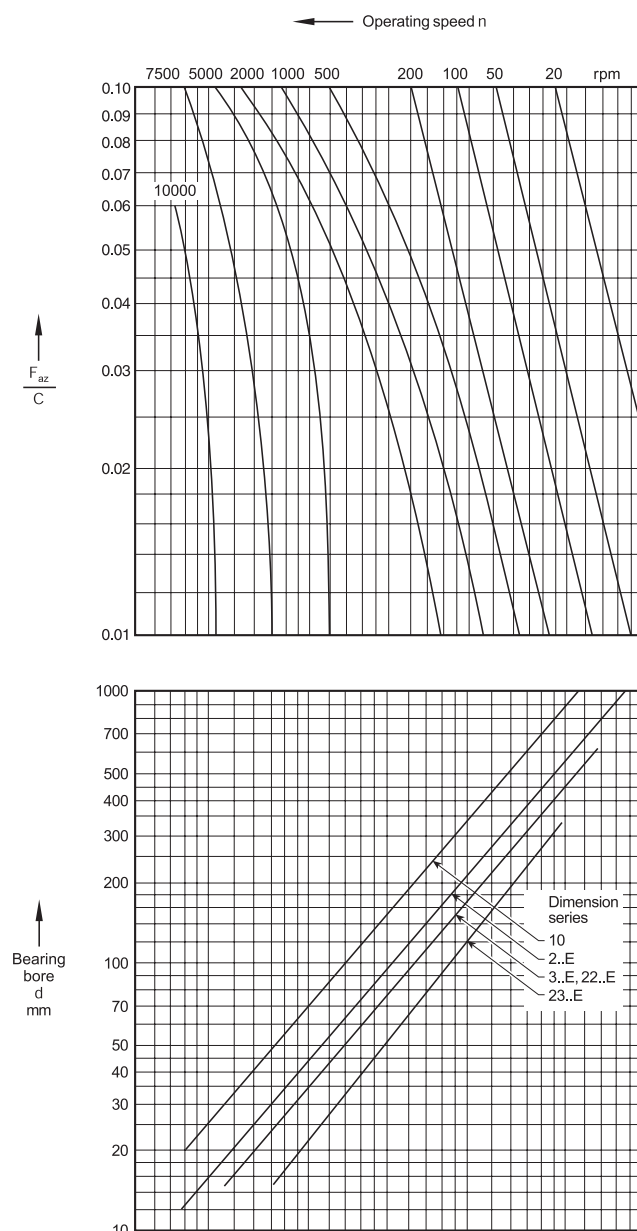
BEARING REACTIONS, DYNAMIC EQUIVALENT LOADS & BEARING LIFE - *continued*

The basic dynamic load rating and the static load rating are commonly used for bearing selection. The basic dynamic load rating is used to estimate life of a rotating bearing. Static load ratings are used to determine the maximum permissible load that can be applied to a non-rotating bearing.

The basic philosophy of The Timken Company is to provide the most realistic bearing rating to assist our customers in the bearing selection process. Published ratings for Timken bearings include the basic dynamic radial load rating  $C$ . This value is based on a basic rating life of one million revolutions. Timken tapered roller bearings also include the basic dynamic load rating  $C_{90}$ , which is based on rating life of ninety million revolutions. The basic static radial load rating is  $C_0$ .

### Static load rating

The basic static radial load rating and thrust load rating for Timken bearings are based on a maximum contact stress within a non-rotating bearing of 4000 MPa (580 ksi) for roller bearings and 4200 MPa (607 ksi) for ball bearings, at the center of contact on the most heavily loaded rolling element.

The 4000 MPa (580 ksi) or 4200 MPa (607 ksi) stress levels may cause visible light brinell marks on the bearing raceways. This degree of marking will not have a measurable effect on fatigue life when the bearing is subsequently rotating under a lower application load. If sound, vibration or torque are critical, or if a pronounced shock load is present, a lower load limit should be applied. For more information on selecting a bearing for static load conditions, consult your Timken representative.

BEARING REACTIONS, DYNAMIC EQUIVALENT LOADS & BEARING LIFE - *continued*

**STATIC RADIAL AND/OR AXIAL EQUIVALENT LOADS**

The static equivalent radial and/or axial loading is dependent on the bearing type selected. For bearings designed to accommodate only radial or thrust loading, the static equivalent load is equivalent to the applied load.

For all bearings, the maximum contact stress can be approximated using the static equivalent load and the static rating.

For roller bearings:

$$\sigma_0 = 4000 \cdot \left( \frac{P_0}{C_0} \right)^{1/2} \text{ MPa}$$

$$\sigma_0 = 580 \cdot \left( \frac{P_0}{C_0} \right)^{1/2} \text{ ksi}$$

For ball bearings:

$$\sigma_0 = 4200 \cdot \left( \frac{P_0}{C_0} \right)^{1/3} \text{ MPa}$$

$$\sigma_0 = 607 \cdot \left( \frac{P_0}{C_0} \right)^{1/3} \text{ ksi}$$

**Radial ball bearings**

The dynamic equivalent radial load is used for comparison with the static load rating. Refer to the Dynamic Equivalent Radial and/or Axial Loads section.

**Thrust ball bearings**

Similar to radial ball bearings, thrust ball bearings use the same equation for equivalent static and dynamic loading.

$$P_{0a} = X \cdot F_r + Y \cdot F_a$$

The X and Y factors are listed in the bearing tables along with the minimum required thrust load-to-radial load ratio for maintaining proper operation.

**Radial spherical roller bearings**

The load factors X<sub>0</sub> and Y<sub>0</sub>, which are listed in the bearing tables, are used with the following equation to estimate the static radial equivalent load.

$$P_{0r} = X_0 \cdot F_r + Y_0 \cdot F_a$$

**Thrust spherical roller bearings**

The following equation is used for thrust spherical roller bearings.

$$P_{0a} = F_a + 2.7 F_r$$

Thrust spherical roller bearings require a minimum thrust load for proper operation. P<sub>0a</sub> = should not be greater than 0.5 C<sub>0a</sub>. If conditions exceed this, consult your Timken representative.

**Tapered roller bearings**

To determine the static equivalent radial load for a single-row mounting, first determine the thrust load, (F<sub>a</sub>), then use the equations in this section, depending on the appropriate thrust load condition.

**Needle roller bearings**

Because radial needle roller bearings are not designed to accept thrust loading, their equation to determine static radial equivalent load is:

$$P_{0r} = F_r$$

Thrust needle roller bearings are not designed to accept radial loading, so their equation to determine static thrust equivalent load is:

$$P_{0a} = F_a$$

**Static equivalent radial load (two-row bearings)**

The bearing data tables do not include static rating for two-row bearings. The two-row static radial rating can be estimated as:

$$C_{0(2)} = 2C_0$$

where:

C<sub>0(2)</sub> = two-row static radial rating

C<sub>0</sub> = static radial load rating of a single row bearing, type TS, from the same series

Thrust Condition	Net Bearing Thrust Load	Static Equivalent Radial Load (P <sub>0</sub> )
$\frac{0.47 F_{rA}}{K_A} \leq \frac{0.47 F_{rB}}{K_B} + F_{ae}$	$F_{aA} = \frac{0.47 F_{rB}}{K_B} + F_{ae}$ $F_{aB} = \frac{0.47 F_{rB}}{K_B}$	$P_{0B} = F_{rB}$ for $F_{aA} < 0.6 F_{rA} / K_A$ $P_{0A} = 1.6 F_{rA} - 1.269 K_A F_{aA}$ for $F_{aA} > 0.6 F_{rA} / K_A$ $P_{0A} = 0.5 F_{rA} + 0.564 K_A F_{aA}$
$\frac{0.47 F_{rA}}{K_A} > \frac{0.47 F_{rB}}{K_B} + F_{ae}$	$F_{aA} = \frac{0.47 F_{rA}}{K_A}$ $F_{aB} = \frac{0.47 F_{rA}}{K_A} - F_{ae}$	for $F_{aB} > 0.6 F_{rB} / K_B$ $P_{0B} = 0.5 F_{rB} + 0.564 K_B F_{aB}$ for $F_{aB} < 0.6 F_{rB} / K_B$ $P_{0B} = 1.6 F_{rB} - 1.269 K_B F_{aB}$ $P_{0A} = F_{rA}$

Please refer to illustrations on page A169.

where:

F<sub>r</sub> = applied radial load

F<sub>a</sub> = net bearing thrust load. F<sub>aA</sub> and F<sub>aB</sub> calculated from equations.

Note: Use the values of P<sub>0</sub> calculated for comparison with the static rating, C<sub>0</sub>, even if P<sub>0</sub> is less than the radial applied, F<sub>r</sub>.

BEARING REACTIONS, DYNAMIC EQUIVALENT LOADS & BEARING LIFE - *continued*

## BEARING LIFE

Many different performance criteria exist that dictate how a bearing should be selected. These include bearing fatigue life, rotational precision, power requirements, temperature limits, speed capabilities, sound, etc. This publication deals primarily with bearing life as related to material associated fatigue. Bearing life is defined here as the length of time, or number of revolutions, until a fatigue spall of 6 mm<sup>2</sup> (0.01 in.<sup>2</sup>) develops. Since metal fatigue is a statistical phenomenon, the life of an individual bearing is impossible to precisely predetermine. Bearings that may appear to be identical can exhibit considerable life scatter when tested under identical conditions. Thus it is necessary to base life predictions on a statistical evaluation of a large number of bearings operating under similar conditions. The Weibull distribution function is commonly used to predict the life of a population of bearings at any given reliability level.

## RATING LIFE

Rating life, ( $L_{10}$ ), is the life that 90 percent of a group of apparently identical bearings will complete or exceed before a fatigue spall develops. The  $L_{10}$  life also is associated with 90 percent reliability for a single bearing under a certain load.

## BEARING LIFE EQUATIONS

Traditionally, the  $L_{10}$  life has been calculated as follows for bearings under radial or combined loading where the dynamic equivalent radial load, ( $P_r$ ), has been determined:

$$L_{10} = \left( \frac{C}{P_r} \right)^e (1 \times 10^6) \text{ revolutions}$$

or,

$$L_{10} = \left( \frac{C}{P_r} \right)^e \left( \frac{1 \times 10^6}{60n} \right) \text{ hours}$$

For thrust bearings, the above equations change to the following.

$$L_{10} = \left( \frac{C_a}{P_a} \right)^e (1 \times 10^6) \text{ revolutions}$$

or,

$$L_{10} = \left( \frac{C_a}{P_a} \right)^e \left( \frac{1 \times 10^6}{60n} \right) \text{ hours}$$

$$e = 3 \text{ for ball bearings}$$

$$= 10/3 \text{ for roller bearings}$$

Tapered roller bearings often use a dynamic load rating based on ninety million cycles, as opposed to one million cycles, changing the equations as follows.

$$L_{10} = \left( \frac{C_{90}}{P_r} \right)^{10/3} (90 \times 10^6) \text{ revolutions}$$

or,

$$L_{10} = \left( \frac{C_{90}}{P_r} \right)^{10/3} \left( \frac{90 \times 10^6}{60n} \right) \text{ hours}$$

and

$$L_{10} = \left( \frac{C_{90a}}{P_a} \right)^{10/3} (90 \times 10^6) \text{ revolutions}$$

or,

$$L_{10} = \left( \frac{C_{90a}}{P_a} \right)^{10/3} \left( \frac{90 \times 10^6}{60n} \right) \text{ hours}$$

As the first set of equations for radial bearings with dynamic ratings based on one million revolutions is the most common form of the equations, this will be used through the rest of this section. The equivalent dynamic load equations and the life adjustment factors are applicable to all forms of the life equation.

With increased emphasis on the relationship between the reference conditions and the actual environment in which the bearing operates in the machine, the traditional life equations have been expanded to include certain additional variables that affect bearing performance. The approach whereby these factors, including a factor for useful life, are considered in the bearing analysis and selection, has been termed Bearing Systems Analysis (BSA).

The ISO/ABMA expanded bearing life equation is:

$$L_{10a} = a_1 a_2 a_3 L_{10}$$

Where,

- $a_1$  = Reliability Life Factor
- $a_2$  = Material Life Factor
- $a_3$  = Operating Condition Life Factor
- (to be specified by the manufacturer)

The Timken expanded bearing life equation is:

$$L_{10a} = a_1 a_2 a_{3d} a_{3h} a_{3k} a_{3l} a_{3m} a_{3p} \left( \frac{C}{F_r} \right)^e (1 \times 10^6)$$

Where,

- $a_1$  = Reliability Life Factor
- $a_2$  = Material Life Factor
- $a_{3d}$  = Debris Life Factor
- $a_{3h}$  = Hardness Life Factor
- $a_{3k}$  = Load Zone Life Factor
- $a_{3l}$  = Lubrication Life Factor
- $a_{3m}$  = Misalignment Life Factor
- $a_{3p}$  = Low Load Life Factor

BEARING REACTIONS, DYNAMIC EQUIVALENT LOADS & BEARING LIFE - *continued*

**Reliability Life Factor (a<sub>1</sub>)**

The equation for the life adjustment factor for reliability is:

$$a_1 = 4.26 \cdot \left( \ln \frac{100}{R} \right)^{2/3} + 0.05$$

ln = natural logarithm (base e)

To adjust the calculated L<sub>10</sub> life for reliability, multiply by the a<sub>1</sub> factor. If 90 (90 percent reliability) is substituted for R in the above equation, a<sub>1</sub> = 1. For R = 99 (99 percent reliability), a<sub>1</sub> = 0.25. The following table lists the reliability factor for commonly used reliability values.

R (percent)	L <sub>n</sub>	a <sub>1</sub>
90	L <sub>10</sub>	1.00
95	L <sub>5</sub>	0.64
96	L <sub>4</sub>	0.55
97	L <sub>3</sub>	0.47
98	L <sub>2</sub>	0.37
99	L <sub>1</sub>	0.25
99.5	L <sub>0.5</sub>	0.175
99.9	L <sub>0.1</sub>	0.093

Note that the equation for reliability adjustment assumes there is a short minimum life below which the probability of bearing damage is minimal (e.g., zero probability of bearing damage producing a short life). Extensive bearing fatigue life testing has shown the minimum life, below which the probability of bearing damage is negligible, to be larger than shown above. For a more accurate prediction of bearing lives at high levels of reliability, consult your Timken representative.

**Material Life Factor (a<sub>2</sub>)**

The life adjustment factor for bearing material, (a<sub>2</sub>), for standard Timken bearings manufactured from bearing quality steel is 1.0. Bearings also are manufactured from premium steels, containing fewer and smaller inclusion impurities than standard steels and providing the benefit of extending bearing fatigue life (e.g., DuraSpexx™). Application of the material life factor requires that fatigue life is limited by nonmetallic inclusions, that contact stresses are approximately less than 2400 MPa (350 ksi), and adequate lubrication is provided. It is important to note that improvements in material cannot offset poor lubrication in an operating bearing system. Consult your Timken representative for applicability of the material factor.

**Debris Life Factor (a<sub>3d</sub>)**

Debris within a lubrication system reduces the life of a roller bearing by creating indentations on the contacting surfaces, leading to stress risers. The Timken life rating equations were developed based on test data obtained with 40 μm oil filtration, and measured ISO cleanliness levels of approximately 15/12, which is typical of cleanliness levels found in normal industrial machinery. When more or less debris is present within the system, the fatigue life predictions can be adjusted according to the measured or expected ISO lubricant cleanliness level to more accurately reflect the expected bearing performance.

As opposed to determining the debris life factor based on filtration and ISO cleanliness levels, a Debris Signature Analysis™ can be performed for more accurate bearing performance predictions. The Debris Signature Analysis is a process for determining the effects of the actual debris present in your system on the bearing performance. The typical way in which this occurs is through measurements of dented/bruised surfaces on actual bearings run in a given application. This type of analysis can be beneficial because different types of debris cause differing levels of performance, even when they are of the same size and amount in the lubricant. Soft, ductile particles can cause less performance degradation than hard, brittle particles. Hard, ductile particles are typically most detrimental to bearing life. Brittle particles can break down, thus not affecting performance to as large of a degree as hard ductile particles. For more information on Debris Signature Analysis or the availability of Debris Resistant bearings for your application, consult your Timken representative.

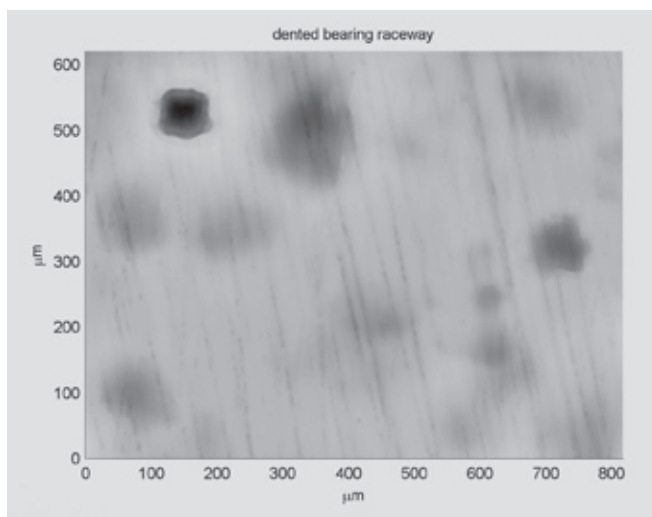

Surface map of a bearing raceway with debris denting.





**BEARING REACTIONS, DYNAMIC EQUIVALENT LOADS & BEARING LIFE - continued**

**Hardness Life Factor (a<sub>3h</sub>)**

Both the dynamic and static load ratings of Timken bearings are based on a minimum raceway hardness equivalent to 58 on the Rockwell C scale (HRC) [ASTM E-18]. If the raceway hardness must be decreased, these load ratings also will be decreased. For Timken bearings supplied as a full assembly, the hardness life factor will be unity. For bearing applications designed to use the shaft or housing surfaces as raceways, this factor can be used to estimate performance when the required 58 HRC minimum hardness cannot be achieved.

The effective raceway hardness affects the life of a bearing application as shown in the following table. If values for raceway hardness below 45 HRC are required, consult your Timken representative.

Raceway Hardness (HRC)	a <sub>3h</sub>
58	1.00
57	0.81
56	0.66
55	0.53
54	0.43
53	0.35
52	0.28
51	0.22
50	0.18
49	0.14
48	0.11
47	0.09
46	0.07
45	0.06

**Load Zone Life Factor (a<sub>3k</sub>)**

The fatigue life of a bearing is a function of the stresses in rollers and raceways and the number of stress cycles that the loaded bearing surfaces experience in one bearing revolution. The stresses depend on applied load and on how many rollers support that load. The number of stress cycles depends on bearing geometry and, again, on how many rollers support the load. Therefore, life for a given external load is related to the loaded arc, or load zone, of the bearing.

The load zone in a bearing is dominated by the internal clearance, either radial or axial depending on the bearing type. Neglecting preload, less clearance in a bearing results in a larger load zone and subsequently longer bearing life.

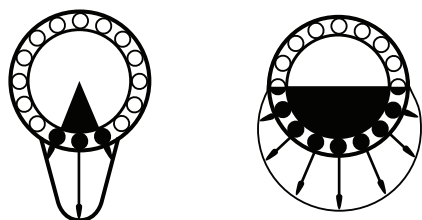

Bearing Load Zones and Roller-Raceway Contact Loading.

Using the dynamic equivalent load (Pr) instead of the applied radial load (Fr) in the equation for L<sub>10a</sub> roughly approximates the load zone factor for combined loading only. If a more accurate assessment of the load zone adjusted life is necessary (e.g., including the effects of internal clearance or fitting practice), consult your Timken representative.

**Lubrication Life Factor (a<sub>3l</sub>)**

The influence of lubrication film due to elastohydrodynamic (EHL) lubrication on bearing performance is related to the reduction or prevention of asperity (metal-metal) contact between the bearing surfaces. Extensive testing has been done at Timken Research to quantify the effects of the lubrication related parameters on bearing life. It has been found that the roller and raceway surface finish, relative to lubricant film thickness, has the most notable effect on improving bearing performance. Factors such as bearing geometry, material, loads and load zones also play an important role in bearing performance.

The following equation provides a method to calculate the lubrication factor for a more accurate prediction of the influence of lubrication on bearing life (L<sub>10a</sub>).

$$a_{3l} = C_g \cdot C_l \cdot C_j \cdot C_s \cdot C_v \cdot C_{gr}$$

Where:

- C<sub>g</sub> = geometry factor
- C<sub>l</sub> = load factor
- C<sub>j</sub> = load zone factor
- C<sub>s</sub> = speed factor
- C<sub>v</sub> = viscosity factor
- C<sub>gr</sub> = grease lubrication factor

Note: The a<sub>3l</sub> maximum is 2.88 for all bearings. The a<sub>3l</sub> minimum is 0.200 for case carburized bearings and 0.126 for through hardened bearings.

A lubricant contamination factor is not included in the lubrication factor because Timken endurance tests are typically run with a 40 µm filter to provide a realistic level of lubricant cleanliness for most applications.

**Geometry factor - C<sub>g</sub>**

C<sub>g</sub> is given for most part numbers in the bearing tables. The geometry factor also includes the material effects and load zone considerations for non-tapered roller bearings, as these also are inherent to the bearing design. However, it should be noted that the primary effect of the load zone is on roller load distributions and contact stresses within the bearing, which are not quantified within the lubrication factor. Refer to the previous section Load Zone Life Factor (a<sub>3k</sub>) for more information.

Note that the geometry factor (C<sub>g</sub>) factor is not applicable to our DuraSpexx™ product. For more information on our DuraSpexx™ product, consult your Timken representative.

BEARING REACTIONS, DYNAMIC EQUIVALENT LOADS & BEARING LIFE - *continued*

**Load factor -  $C_l$**

The  $C_l$  factor is obtained from the following figure. Note that the factor is different based on the type of bearing utilized.  $P_r$  is the equivalent load applied to the bearing in Newtons and is determined in the Equivalent Bearing Loads ( $P_r$ ) section.

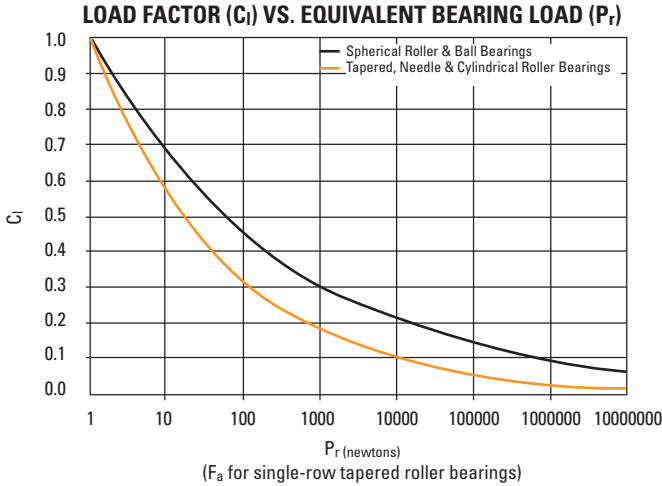

**Load zone factor -  $C_j$**

As mentioned previously, for all non-tapered roller bearings the load zone factor is unity. For tapered roller bearings, the load zone factor can be taken from the graph based on the thrust load applied to that bearing.

**LOAD ZONE FACTOR ( $C_j$ ) VS. TAPERED BEARING THRUST LOAD ( $F_a$ )**

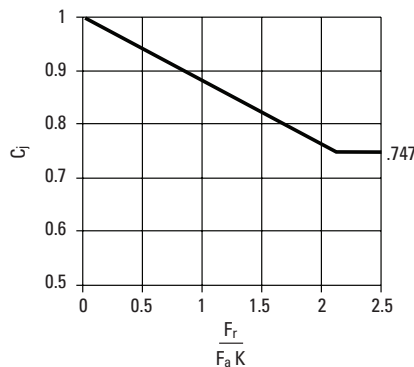

**Speed factor -  $C_s$**

$C_s$  is determined from the following figure, where rev/min (RPM) is the rotational speed of the inner ring relative to the outer ring.

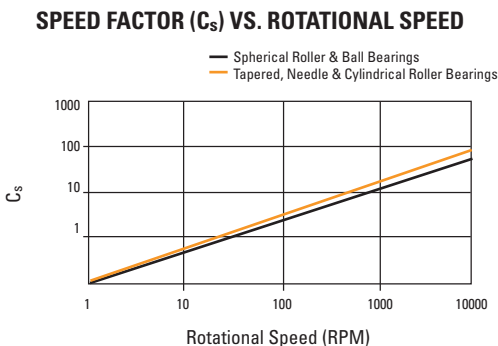

**Viscosity factor -  $C_v$**

The lubricant kinematic viscosity [centistokes (cSt)] is taken at the operating temperature of the bearing. The operating viscosity can be estimated by using the figure in the Speed, Heat and Torque section. The viscosity factor ( $C_v$ ) can then be determined from the following figure.

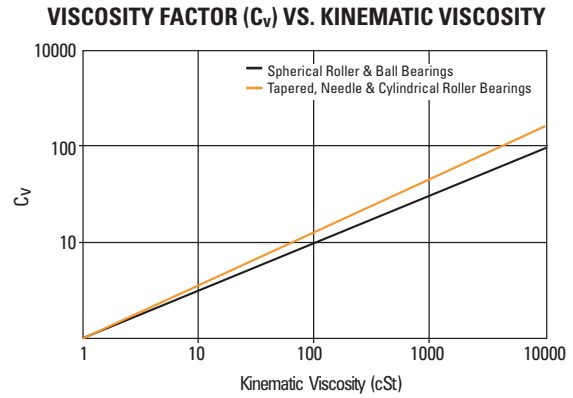

**Grease lubrication factor -  $C_{gr}$**

For grease lubrication, the EHL lubrication film becomes depleted of oil over time and is reduced in thickness. Consequently, a reduction factor ( $C_{gr}$ ) should be used to adjust for this effect.

$C_{gr} = 0.79$

**Misalignment life factor ( $a_{3m}$ )**

The effect of bearing life depends on the magnitude of the angle of misalignment, on the internal bearing geometry, and on the applied loads.

The misalignment life factor for spherical bearings is equal to one,  $a_{3m} = 1$ , due to the self-aligning capabilities of a spherical roller bearing. The allowable misalignment in a spherical roller bearing is between 1 degree and 2.5 degrees, depending upon the series of the bearing as detailed in the following table. Life will be reduced if these limits are exceeded, due to roller-raceway contact truncation.

**MAXIMUM PERMISSIBLE MISALIGNMENTS FOR SPHERICAL ROLLER BEARINGS BASED ON SERIES**

Bearing Series	Maximum Misalignment
238	±1.0°
222, 230, 231, 239, 249	±1.5°
223, 240	±2.0°
232, 241	±2.5°





**BEARING REACTIONS, DYNAMIC EQUIVALENT LOADS & BEARING LIFE - continued**

For needle roller bearings, the following table gives the misalignment limitations based on bearing width.

Bearing Width		Maximum Slope	
mm	inches	Caged	Full Complement
> 50	> 2	0.0005	0.0005
25-50	1-2	0.0010	0.0005
< 25	< 1	0.0015	0.0010

For all other bearing types, accurate alignment of the shaft relative to the housing is critical for best performance. The life prediction using the method defined in this publication is relatively accurate up to the limits listed within, based on bearing type. The base condition for which the load rating of the roller bearings are defined is 0.0005 radians misalignment.

For cylindrical roller bearings, the misalignment factor also is a measure of the effect of bearing axial load on life. Axial loading of the bearing causes a moment to be generated about the roller center, thus shifting the roller-raceway contact stresses toward the end of the roller, similar to bearing misalignment.

Performance of all Timken bearings under various levels of misalignment, radial and axial load can be predicted using sophisticated computer programs. Using these programs, Timken engineers can design special bearing contact profiles to accommodate the conditions of radial load, axial load and/or bearing misalignment in your application. Consult your Timken representative for more information.

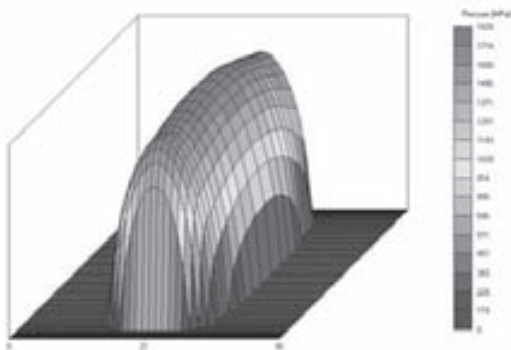

Roller-inner raceway contact stress without misalignment.

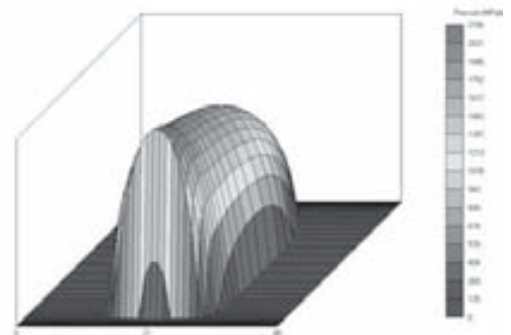

Roller-inner raceway contact stress with high misalignment and special profile.

**Needle rollers with relieved ends**

Needle roller bearing life is affected by the distribution of contact stress between roller and raceways. Even when non-profiled needle rollers are loaded under conditions of ideal alignment, the contact stress is not uniform along the length of the rollers, but rather is concentrated towards the ends. Misalignment causes even greater roller contact stress. This effect is illustrated below.

Needle Roller – Cylindrical

Needle Roller- Relieved Ends (exaggerated for clarity)

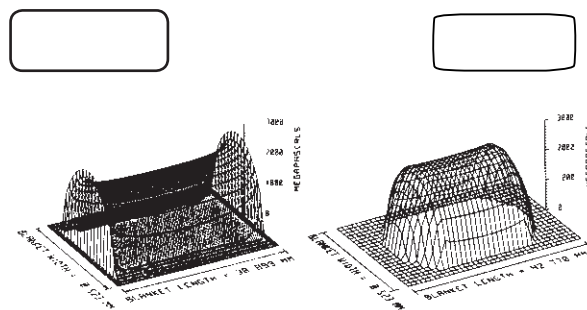
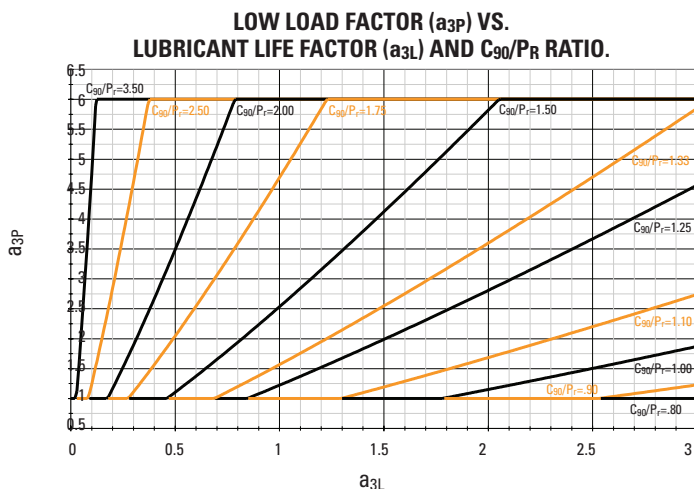

**Fig. A-11**  
Comparative Stress Patterns

The use of needle rollers with relieved ends helps to reduce stress concentration at the ends of rollers, both under misalignment or ideal alignment, and results in more uniform stress distribution and optimum bearings performance.

**Low load life factor ( $a_{3p}$ )**

Bearing life tests at the Timken Technology Center have shown greatly extended bearing fatigue life performance is achievable when the bearing contact stresses are low and the lubricant film is sufficient to fully separate the micro-scale textures of the contacting surfaces. Mating the test data with sophisticated computer programs for predicting bearing performance, Timken engineers have developed a low load factor for use in the catalog to predict the life increase expected when operating under low bearing loads. The following figure shows the low load factor ( $a_{3p}$ ) as a function of the lubricant life factor ( $a_{3L}$ ) and the ratio of bearing dynamic rating to the bearing equivalent load.



**BEARING REACTIONS, DYNAMIC EQUIVALENT LOADS & BEARING LIFE - continued**

**LIFE - THRUST SPHERICAL, CYLINDRICAL AND TAPERED ROLLER BEARINGS**

The life formula, below, is the radial roller bearing life equation restated in terms of thrust instead of radial ratings and radial equivalent loads.

$$L_{10} = \frac{16667}{n} \left[ \frac{C_t}{T_e} \right]^{10/3} \text{ (Hours)}$$

The calculations of bearing life may also be performed by using logarithmic factors for rotational speed ( $N_f$ ) and life ( $L_f$ ) based on the formula:

$$L_{10} = 500 (L_f)^{10/3} \text{ (Hours)}$$

where  $L_f = \left[ \frac{C_t n_f}{T_e} \right]$

where  $N_f = \left[ \frac{1}{.03n} \right]^{3/10}$

Referring back to the above equation it may be advisable, as previously noted with radial bearings, under certain operating conditions to include an application factor  $a_3$  and calculate life according to the formula:

$$L_{10} = \frac{16667}{n} a_3 \left[ \frac{C_t}{T_e} \right]^{10/3} \text{ or } L_{10} = 500 a_3 (L_f)^{10/3} \text{ (Hours)}$$

$a_3$  is the factor based on application conditions. Under optimum conditions  $a_3 = 1$ . Depending on lubricant contamination, temperatures, impact loading and load reversals  $a_3$  may be less than 1 and as low as 0.05. Consult your Timken representative for assistance with your specific application requirements.

**LIFE - THRUST BALL BEARINGS**

$$L_{10} = \frac{16667}{n} \left[ \frac{C_t}{T_e} \right]^3 \text{ (Hours)}$$

It may be advisable under certain operating conditions to include an application factor  $a_3$  and calculate life according to the formula:

$$L_{10} = \frac{16667}{n} a_3 \left[ \frac{C_t}{T_e} \right]^3 \text{ (Hours)}$$

$a_3$ , the life factor based on application conditions, can be assigned values as described above.



# BEARING TOLERANCES, INCH & METRIC

## TOLERANCES

Standards defining practices for ball and roller bearing usage are listed in the following tables. These standards are provided for use in selecting bearings for general applications in conjunction with the bearing mounting and fitting practices offered in later sections.

## RADIAL BALL, SPHERICAL AND CYLINDRICAL ROLLER BEARINGS

Depending on your specific application requirements, various degrees of bearing accuracy may be required.

Timken maintains ball diameter and sphericity tolerances, close control of race contours and internal clearances, accuracy of cage construction, and unusually fine surface finishes.

STANDARD ABEC / RBEC TOLERANCES - INNER RING																									
All tolerances in number of micrometers (µm) and ten-thousandths inch (.0001")																									
Bearing Bore	Bore Numbers Reference	Bore Diameter $\Delta_{dmp}$					Width Variation $V_{Bs}$					Raceway Radial Runout $K_{ia}$					Face Runout With Bore $S_d$			Raceway Axial Runout $S_{ia}$			Width Inner & Outer Rings $\Delta_{Bs} \& \Delta_{Cs}$		
		+0.000 mm +0.0000"																					+0.000 mm +0.0000"		
mm		ABEC					ABEC					ABEC					ABEC			ABEC			ABEC		
		RBEC					RBEC					RBEC					RBEC			RBEC			RBEC		
over	incl.	1	3	5	7	9	1	3	5	7	9	1	3	5	7	9	5	7	9	5	7	9	1,3	5,7,9	
		mm in.	mm in.	mm in.	mm in.	mm in.	mm in.	mm in.	mm in.	mm in.	mm in.	mm in.	mm in.	mm in.	mm in.	mm in.	mm in.	mm in.	mm in.	mm in.	mm in.	mm in.	mm in.	mm in.	
2.5	10	30-39	-8	-7	-5	-4	-2.5	15	15	5	2.5	1.5	10	6	4	2.5	1.5	7	3	1.5	7	3	1.5	-120	-40
			-3	-3	-2	-1.5	-1	6	6	2	1	0.5	4	2.5	1.5	1	0.5	3	1	0.5	3	1	0.5	-50	-15
			-8	-7	-5	-4	-2.5	20	20	5	2.5	1.5	10	7	4	2.5	1.5	7	3	1.5	7	3	1.5	-120	-80
10	18	00-03	-3	-3	-2	-1.5	-1	8	8	2	1	0.5	4	3	1.5	1	0.5	3	1	0.5	3	1	0.5	-50	-30
			-10	-8	-6	-5	-2.5	20	20	5	2.5	1.5	13	8	4	3	2.5	8	4	1.5	8	4	2.5	-120	-120
18	30	04-06	-4	-3	-2.5	-2	-1	8	8	2	1	0.5	5	3	1.5	1	3	1.5	0.5	3	1.5	1	-50	-50	
			-12	-10	-8	-6	-2.5	20	20	5	3	1.5	15	10	5	4	2.5	8	4	1.5	8	4	2.5	-120	-120
30	50	07-10	-4.5	-4	-3	-2.5	-1	8	8	2	1	0.5	6	4	2	1.5	1	3	1.5	0.5	3	1.5	1	-50	-50
			-15	-12	-9	-7	-4	25	25	6	4	1.5	20	10	5	4	2.5	8	5	1.5	8	5	2.5	-150	-150
50	80	11-16	-6	-4.5	-3.5	-3	-1.5	10	10	2.5	1.5	0.5	8	4	2	1.5	1	3	2	0.5	3	2	1	-60	-60
			-20	-15	-10	-8	-5	25	25	7	4	2.5	25	13	6	5	2.5	9	5	2.5	9	5	2.5	-200	-200
80	120	17-24	-8	-6	-4	-3	-2	10	10	3	1.5	1	10	5	2.5	2	1	3.5	2	1	3.5	2	1	-80	-80
			-25	-18	-13	-10	-7	30	30	8	5	2.5	30	18	8	6	2.5	10	6	2.5	10	7	2.5	-250	-250
120	150	26-30	-10	-7	-5	-4	-3	12	12	3	2	1	12	7	3	2.5	1	4	2.5	1	4	3	1	-100	-100
			-25	-18	-13	-10	-7	30	30	8	5	4	30	18	8	6	5	10	6	4	10	7	5	-250	-250
150	180	32-36	-10	-7	-5	-4	-3	12	12	3	2	1.5	12	7	3	2.5	2	4	2.5	1.5	4	3	2	-100	-100
			-30	-22	-15	-12	-8	30	30	10	6	5	40	20	10	8	5	11	7	5	13	8	5	-300	-300
180	250	38-50	-12	-8.5	-6	-4.5	-3	12	12	4	2.5	2	16	8	4	3	2	4.5	3	2	5	3	2	-120	-120
			-35	-25	-18	—	—	35	35	13	—	—	50	25	13	—	—	13	—	—	15	—	—	-350	-350
250	315	52-60	-14	-10	-7	—	—	14	14	5	—	—	20	10	5	—	—	5	—	—	6	—	—	-140	-140
			-40	-30	-23	—	—	40	40	15	—	—	60	30	15	—	—	15	—	—	20	—	—	-400	-400
315	400	64-80	-16	-12	-9	—	—	16	16	6	—	—	24	12	6	—	—	6	—	—	8	—	—	-160	-160
			-45	-35	—	—	—	50	45	—	—	—	65	35	—	—	—	—	—	—	—	—	—	-450	—
400	500		-18	-14	—	—	—	20	18	—	—	—	26	14	—	—	—	—	—	—	—	—	—	-180	—
			-50	-40	—	—	—	60	50	—	—	—	70	40	—	—	—	—	—	—	—	—	—	-500	—
500	630		-20	-16	—	—	—	24	20	—	—	—	28	16	—	—	—	—	—	—	—	—	—	-200	—
			-75	—	—	—	—	70	—	—	—	—	80	—	—	—	—	—	—	—	—	—	—	-750	—
630	800		-30	—	—	—	—	28	—	—	—	—	31	—	—	—	—	—	—	—	—	—	—	-300	—

The tolerances in this table are in conformance with ANSI ABMA Standard 20 - 1987.

<p><b>ABMA / ISO Symbols - Inner Ring</b></p> <p><math>\Delta_{dmp}</math> Single plane mean bore diameter deviation from basic bore diameter, e.g., bore tolerance for a basically tapered bore, <math>\Delta_{dmp}</math> refers only to the theoretical small bore end of the bore</p> <p><math>K_{ia}</math> Radial runout of assembled bearing inner ring, e.g., radial runout of raceway</p> <p><math>V_{Bs}</math> Inner ring width variation, e.g., parallelism</p> <p><math>S_d</math> Inner ring reference face runout with bore, e.g., squareness - bore to face</p> <p><math>S_{ia}</math> Axial runout of assembled bearing inner ring, e.g., lateral (axial) runout of raceway</p> <p><math>\Delta_{Bs}</math> Single inner ring width deviation from basic, e.g., width tolerance</p>	<p><b>ABMA / ISO Symbols - Outer Ring</b></p> <p><math>\Delta_{Dmp}</math> Single plane mean outside diameter deviation from basic outside diameter, e.g., O.D. tolerance</p> <p><math>K_{ea}</math> Radial runout of assembled bearing outer ring, e.g., radial runout of raceway</p> <p><math>V_{Cs}</math> Outer ring width variation, e.g., parallelism</p> <p><math>S_D</math> Outside cylindrical surface runout with outer ring reference face, e.g., squareness O.D. to face</p> <p><math>S_{ea}</math> Axial runout of assembled bearing outer ring, e.g., lateral (axial) runout of raceway</p> <p><math>\Delta_{Cs}</math> Outer ring width deviation from basic, e.g., width tolerance</p>
--	--

A BEARING TOLERANCES, INCH & METRIC - continued

These standards, coupled with proprietary design, material and processing specifications, ensure that our bearings offer the maximum performance.

Among the tolerance classes, ABEC 1 applies to ball bearings for normal usage. The other classes ABEC 3, 5, 7, 9 apply to ball bearings of increased precision as required. RBEC 1 applies to roller bearings for normal usage. RBEC 3 and 5 apply to roller bearings of increased precision as required.

STANDARD ABEC / RBEC TOLERANCES - OUTER RING																						
All tolerances in number of micrometers (µm) and ten-thousandths inches (.0001")																						
Bearing O.D.	Ball Bearing Sizes	Outside Diameter <sup>(1)</sup> ΔD <sub>mp</sub>					Width Variation				Raceway Radial Runout					Raceway Axial Runout			Outside Diameter With Face			
		+0.000 mm +0.0000"					V <sub>Cs</sub>				K <sub>ea</sub>					S <sub>ea</sub>			S <sub>D</sub>			
mm over	incl.	ABEC					ABEC				ABEC					ABEC			ABEC			
		RBEC					RBEC				RBEC					RBEC			RBEC			
		1	3	5	7	9	1,3	5	7	9	1	3	5	7	9	5	7	9	5	7	9	
		mm in.	mm in.	mm in.	mm in.	mm in.	mm in.	mm in.	mm in.	mm in.	mm in.	mm in.	mm in.	mm in.	mm in.	mm in.	mm in.	mm in.	mm in.	mm in.	mm in.	
0	18	30-39	-8 -3	-7 -3	-5 -2	-4 -1.5	-2.5 -1	15 6	5 2	2.5 1	1.5 0.5	15 6	8 4	5 2	3 1	1.5 0.5	8 3	5 2	1.5 0.5	8 3	4 1.5	1.5 0.5
18	30	9300-9303 9100-9101	-9	-8	-6	-5	-4	20	5	2.5	1.5	15	9	6	4	2.5	8	5	2.5	8	4	1.5
		200	-3.5	-3	-2.5	-2	-1.5	8	2	1	0.5	6	4	2.5	1.5	1	3	2	1	3	1.5	0.5
		200-204 9304-9306	-11	-9	-7	-6		20	5	2.5	1.5	20	10	7	5	2.5	8	5	2.5	8	4	1.5
30	50	9102-9105 300-303	-4.5	-3.5	-3	-2.5	-1.5	8	2	1	0.5	8	4	3	2	1	3	2	1	3	1.5	0.5
		205-208 9307-9312	-13	-11	-9	-7	-4	25	6	3	1.5	25	13	8	5	4	10	5	4	8	4	1.5
50	80	9106-9110 304-307	-5	-4.5	-3.5	-3	-1.5	10	2.5	1	0.5	10	5	3	2	1.5	4	2	1.5	3	1.5	0.5
		209-213 9313-9317	-15	-13	-10	-8	-5	25	8	4	2.5	35	18	10	6	5	11	6	5	9	5	2.5
80	120	9111-9115 308-311	-6	-5	-4	-3	-2	10	3	1.5	1	14	7	4	2.5	2	4.5	2.5	2	3.5	2	1
		214-217 9318-9322	-18	-15	-11	-9	-5	30	8	5	2.5	40	20	11	7	5	13	7	5	10	5	2.5
120	150	9116-9120 312-314	-7	-6	-4.5	-3.5	-2	12	3	2	1	16	8	4.5	3	2	5	3	2	4	2	1
		218-220 9323-9326	-25	-18	-13	-10	-7	30	8	5	2.5	45	23	13	8	5	14	8	5	10	5	2.5
150	180	9121-9326 315-317	-10	-7	-5	-4	-3	12	3	2	1	18	9	5	3	2	5.5	3	2	4	2	1
		318-322 9126-9132	-30	-20	-15	-11	-8	30	10	7	4	50	25	15	10	7	15	10	7	11	7	4
180	250	220-228	-12	-8	-6	-4.5	-3	12	4	3	1.5	20	10	6	4	3	6	4	3	4.5	3	1.5
		324-328	-35	-25	-18	-13	-8	35	11	7	5	60	30	18	11	7	18	10	7	13	8	5
250	315	9134-9140	-14	-10	-7	-5	-3	14	4.5	3	2	24	12	7	4.5	3	7	4	3	5	3	2
		330-338	-40	-28	-20	-15	-10	40	13	8	7	70	35	20	13	8	20	13	8	13	10	7
315	400	9144-9152	-16	-11	-8	-6	-4	16	5	3	3	28	14	8	5	3	8	5	3	5	4	3
		236-244	-16	-11	-8	-6	-4	16	5	3	3	28	14	8	5	3	8	5	3	5	4	3
400	500	340-348 9156-9164	-45	-33	-23	—	—	45	15	—	—	80	40	23	—	—	23	—	—	15	—	—
		246-256	-18	-13	-9	—	—	18	6	—	—	31	16	9	—	—	9	—	—	6	—	—
500	630	352-356 9180	-50	-38	-28	—	—	50	18	—	—	100	50	25	—	—	25	—	—	18	—	—
		260-264	-20	-15	-11	—	—	20	7	—	—	39	20	10	—	—	10	—	—	7	—	—
630	800		-75	-45	-35	—	—	—	20	—	—	120	60	30	—	—	30	—	—	20	—	—
			-30	-18	-14	—	—	—	8	—	—	47	24	12	—	—	12	—	—	8	—	—
800	1000		-100	-60	—	—	—	—	—	—	—	140	75	—	—	—	—	—	—	—	—	—
			-40	-24	—	—	—	—	—	—	—	55	30	—	—	—	—	—	—	—	—	—
1000	1250		-125	—	—	—	—	—	—	—	—	160	—	—	—	—	—	—	—	—	—	—
			-50	—	—	—	—	—	—	—	—	63	—	—	—	—	—	—	—	—	—	—

The tolerances in this table are in conformance with ANSI ABMA Standard 20 - 1987.

<sup>(1)</sup> D<sub>min</sub> (the smallest single diameter of an O.D.) and D<sub>max</sub> (the largest single diameter of an O.D.) may fall outside limits shown  $\frac{D_{min} + D_{max}}{2}$  must be within outside diameter tabulated.

2

For further details see ABMA Standard 20.



BEARING TOLERANCES, INCH & METRIC - continued

**TOLERANCES OF CYLINDRICAL ROLLER AND NEEDLE ROLLER BEARINGS**

The tolerances given in the following table apply to inner rings of metric series cylindrical roller and needle roller radial bearing types in which their rings are precision finished.

TABLE 5

TOLERANCES OF CYLINDRICAL ROLLER AND NEEDLE ROLLER RADIAL BEARINGS – INNER RING – METRIC SERIES

Tolerance in micrometers (0.001 mm)												
Tolerance class P0 (normal tolerance)					Tolerance class P6					Tolerance class P5		
		Variation $V_{dsp}$ *diameter series			Variation	Variation $V_{dsp}$ *diameter series			Variation	Variation $V_{dsp}$ *diameter series		Variation
>	≤	9	0	2 & 3	$V_{dmp}$	9	0	2 & 3	$V_{dmp}$	9	0, 2 & 3	$V_{dmp}$
2.5	10	10	8	6	6	9	7	5	5	5	4	3
10	18	10	8	6	6	9	7	5	5	5	4	3
18	30	13	10	8	8	10	8	6	6	6	5	3
30	50	15	12	9	9	13	10	8	8	8	6	4
50	80	19	19	11	11	15	15	9	9	9	7	5
80	120	25	25	15	15	19	19	11	11	10	8	5
120	180	31	31	19	19	23	23	14	14	13	10	7
180	250	38	38	23	23	28	28	17	17	15	12	8
250	315	44	44	26	26	31	31	19	19	18	14	9
315	400	50	50	30	30	38	38	23	23	23	18	12
400	500	56	56	34	34	44	44	26	26			

\* No values have been established for diameter series 8.

**Bore Diameter**

$V_{dsp}$  Difference between the largest and the smallest of the single bore diameters in a single radial plane.

$V_{dmp}$  Difference between the largest and smallest of the mean bore diameters in a single radial plane of an individual ring.

**TOLERANCE TERMS, SYMBOLS AND DEFINITIONS**

**Axes, planes etc.**

**Inner ring (or shaft washer) axis:** Axis of the cylinder inscribed in a basically cylindrical bore. The inner ring (or shaft washer) axis is also the bearing axis.

**Outer ring (or housing washer) axis:** Axis of the cylinder circumscribed around a basically cylindrical outside surface.

**Radial plane:** Plane perpendicular to the bearing or ring axis. It is, however, acceptable to consider radial planes referred to in the definitions as being parallel with the plane tangential to the reference face of a ring or the back face of a thrust bearing washer.

**Radial direction:** Direction through the bearing or ring axis in a radial plane.

**Axial plane:** Plane containing the bearing or ring axis.

**Axial direction:** Direction parallel with the bearing or ring axis. It is, however, acceptable to consider axial directions referred to in the definitions as being perpendicular to the plane tangential to the reference face of a ring or back face of a thrust bearing washer.

**Reference face:** Face designated by the manufacturer of the bearings, and which may be the datum for measurements.

**NOTE:** The reference face for measurement is generally taken as the unmarked face. In case of symmetrical rings when it is not possible to identify the reference face, the tolerances are deemed to comply relative to either face, but not both. The reference face of a shaft and housing washer as a thrust bearing is that face intended to support axial load and is generally opposite the raceway face.

**Outer ring flange back face:** That side of an outer ring flange which is intended to support axial load.

**Middle of raceway:** Point or line on a raceway surface, halfway between the two edges of the raceway.

**Raceway contact diameter:** Diameter of the theoretical circle through the nominal points of contact between the rolling elements and raceway.

**NOTE:** For roller bearings, the nominal point of contact is generally at the middle of the roller.

**Diameter deviation near ring faces:** In radial planes, nearer the face of a ring than 1.2 times the maximum (axial direction) ring chamfer, only the maximum material limits apply.

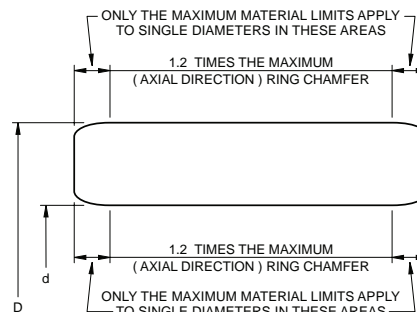

**BEARING TOLERANCES, INCH & METRIC - continued**

The tolerances given in the following table apply to outer rings of metric series cylindrical roller and needle roller radial bearing types in which their rings are precision finished.

**TABLE 6**

TOLERANCES OF CYLINDRICAL ROLLER AND NEEDLE ROLLER RADIAL BEARINGS – OUTER RING – METRIC SERIES												
Tolerance in micrometers (0.001 mm)												
Tolerance class P0 (normal tolerance)						Tolerance class P6				Tolerance class P5		
		Variation $V_{Dsp}$ *diameter series			Variation	**Variation $V_{Dsp}$ *diameter series			Variation	Variation $V_{Dsp}$ *diameter series		Variation
>	≤	9	0	2 & 3	$V_{Dmp}$	9	0	2 & 3	$V_{Dmp}$	9	0, 2 & 3	$V_{Dmp}$
6	18	10	8	6	6	9	7	5	6	5	4	3
18	30	12	9	7	7	10	8	6	7	6	5	3
30	50	14	11	8	8	11	9	7	8	7	5	4
50	80	16	13	10	10	14	11	8	10	9	7	5
80	120	19	19	11	11	16	16	10	11	10	8	5
120	150	23	23	14	14	19	19	11	14	11	8	6
150	180	31	31	19	19	23	23	14	15	13	10	7
180	250	38	38	23	23	25	25	15	19	15	11	8
250	315	44	44	26	26	31	31	19	21	18	14	9
315	400	50	50	30	30	35	35	21	25	20	15	10
400	500	56	56	34	34	41	41	25		23	17	12

\* No values have been established for diameter series 8.

\*\* Applies before inserting and after removal of internal snap ring.

**Outside Diameter**

$V_{Dmp}$  Difference between the largest and the smallest of the mean outside diameters in a single radial plane of an individual ring.

$V_{Dsp}$  Difference between the largest and smallest of the single outside diameters in a single radial plane.





BEARING TOLERANCES, INCH & METRIC - continued

**TOLERANCES OF CYLINDRICAL ROLLER THRUST BEARINGS**

The tolerances given in the following tables apply to thrust washers used in metric series cylindrical roller thrust bearings of dimension series 811 and 812.

TABLE 7

TOLERANCES OF CYLINDRICAL ROLLER THRUST BEARINGS – SHAFT PILOTED WASHER – METRIC SERIES													
Dimensions in mm		Dimensions in micrometers (0.001 mm)											
Nominal bore diameter		Tolerance class P0 (normal tolerance)				Tolerance class P6				Tolerance class P5			
		Deviation		Variation		Deviation		Variation		Deviation		Variation	
>	≤	$\Delta_{dmp}$	$V_{dsp}$	$S_i^*$	$\Delta_{dmp}$	$V_{dsp}$	$S_i^*$	$\Delta_{dmp}$	$V_{dsp}$	$S_i^*$	$\Delta_{dmp}$	$V_{dsp}$	$S_i^*$
	18	0	-8	6	10	0	-8	6	5	0	-8	6	3
18	30	0	-10	8	10	0	-10	8	5	0	-10	8	3
30	50	0	-12	9	10	0	-12	9	6	0	-12	9	3
50	80	0	-15	11	10	0	-15	11	7	0	-15	11	4
80	120	0	-20	15	15	0	-20	15	8	0	-20	15	4
120	180	0	-25	19	15	0	-25	19	9	0	-25	19	5
180	250	0	-30	23	20	0	-30	23	10	0	-30	23	5
250	315	0	-35	26	25	0	-35	26	13	0	-35	26	7
315	400	0	-40	30	30	0	-40	30	15	0	-40	30	7
400	500	0	-45	34	30	0	-45	34	18	0	-45	34	9

\* The values of the wall thickness variation  $S_e$ , for the Housing Piloted washer are identical to  $S_i$  for the Shaft Piloted washers.

TABLE 8

TOLERANCES OF CYLINDRICAL ROLLER THRUST BEARINGS – HOUSING PILOTED WASHER – METRIC SERIES										
Dimensions in mm		Tolerances in micrometers (0.001 mm)								
Nominal outside diameter		Tolerance class P0 (normal tolerance)			Tolerance class P6			Tolerance class P5		
		Deviation		Variation	Deviation		Variation	Deviation		Variation
>	≤	$\Delta_{Dmp}$	$V_{Dsp}$	$\Delta_{Dmp}$	$V_{Dsp}$	$\Delta_{Dmp}$	$V_{Dsp}$	$\Delta_{Dmp}$	$V_{Dsp}$	
	30	0	-13	10	0	-13	10	0	-13	10
30	50	0	-16	12	0	-16	12	0	-16	12
50	80	0	-19	14	0	-19	14	0	-19	14
80	120	0	-22	17	0	-22	17	0	-22	17
120	180	0	-25	19	0	-25	19	0	-25	19
180	250	0	-30	23	0	-30	23	0	-30	23
250	315	0	-35	26	0	-35	26	0	-35	26
315	400	0	-40	30	0	-40	30	0	-40	30
400	500	0	-45	34	0	-45	34	0	-45	34

**ABMA / ISO Symbols - Inner Ring**

- $\Delta_{dmp}$  Single plane mean bore diameter deviation from basic bore diameter, e.g., bore tolerance for a basically tapered bore,  $\Delta_{dmp}$  refers only to the theoretical small bore end of the bore.
- $V_{dsp}$  Difference between the largest and the smallest of the single bore diameters in a single radial plane.
- $V_{dmp}$  Difference between the largest and smallest of the mean bore diameters in a single radial plane of an individual ring.

**ABMA / ISO Symbols - Outer Ring**

- $\Delta_{Dmp}$  Single plane mean outside diameter deviation from basic outside diameter, e.g., O.D. tolerance.
- $V_{Dsp}$  Difference between the largest and smallest of the single outside diameters in a single radial plane.

A BEARING TOLERANCES, INCH & METRIC - continued

**TOLERANCES FOR NEEDLE ROLLER AND CAGE THRUST ASSEMBLIES**

Tolerances for the bore diameters and outside diameters of inch thrust assemblies are given in Table 9.

TABLE 9

TOLERANCES FOR BORE (D <sub>C1</sub> ) AND OUTSIDE (D <sub>C</sub> ) DIAMETERS OF NOMINAL INCH (NTA) NEEDLE ROLLER AND CAGE THRUST ASSEMBLIES				
Needle roller Bore Diameter (D <sub>w</sub> ) (nominal)	Deviations			
	Diameter (D <sub>C1</sub> )		Outside Diameter (D <sub>C</sub> )	
	inch		inch	
inch	low	high	high	low
0.0781	+0.002	+0.007	-0.010	-0.020
0.1250	+0.002	+0.010	-0.010	-0.025

**Bore Inspection Procedure for Assembly**

The bore diameter (D<sub>C1</sub>) of the assembly should be checked with “go” and “no go” plug gages. The “go” plug gage size is the minimum bore diameter of the assembly. The “no go” plug gage size is the maximum bore diameter of the assembly.

The assembly, under its own free weight, must fall freely from the “go” plug gage. The “no go” plug gage must not enter the bore. Where the “no go” plug gage can be forced through the bore, the assembly must not fall from the gage under its own weight.

**THRUST BEARINGS**

The tolerances in this table conform to ANSI/ABMA Standard 21.2.

Certain applications for Timken cylindrical roller bearings may require special precision tolerances. Timken has for many years offered two high-precision tolerance standards which augment the ABMA tolerance system. If your application requires precision beyond ABMA tolerances, consult your Timken representative about extraprecision and ultraprecision tolerances.

**TOLERANCES FOR THRUST WASHERS**

Tolerances for the outside diameters and bore diameters of nominal inch thrust washers are given in Tables 10 and 11.

TABLE 10

TOLERANCES FOR BORE DIAMETER (d) OF NOMINAL INCH (TRA, TRB, ETC.) THRUST WASHERS.			
Nominal bore diameter		Deviations	
inch		inch	
>	≤	low	high
0.24	2.25	+0.002	+0.012
2.25	5.25	+0.002	+0.017

TABLE 11

TOLERANCES FOR OUTSIDE DIAMETER (d <sub>1</sub> ) OF NOMINAL INCH (TRA, TRB ETC.) THRUST WASHERS.			
Nominal O.D.		Deviations	
inch		inch	
>	≤	high	low
0.24	5.25	-0.010	-0.030

**THRUST CYLINDRICAL ROLLER BEARINGS**

TYPE TP									TYPES TPS								
Bore			O.D.			Height			Bore			O.D.			Height		
Bearing over	Bore incl.	Tolerance +0.0	Bearing over	O.D. incl.	Tolerance -0	Bearing over	Bore incl.	Tolerance +0.0	Bearing over	Bore incl.	Tolerance +0.0	Bearing over	O.D. incl.	Tolerance -0	Bearing over	Bore incl.	Tolerance +0.0
mm	mm	mm	mm	mm	mm	mm	mm	mm	mm	mm	mm	mm	mm	mm	mm	mm	mm
50.800	76.200	-0.025	127.000	254.000	+0.038	0.000	50.800	-0.152	50.800	76.200	-0.025	127.000	266.700	+0.048	0.000	50.800	-0.203
2.0000	3.0000	-0.0010	5.0000	10.0000	+0.0015	0.0000	2.0000	-0.0060	2.0000	3.0000	-0.0010	5.0000	10.5000	+0.0019	0.0000	2.0000	-0.0080
76.200	88.900	-0.030	254.000	457.200	+0.051	50.800	76.200	-0.203	76.200	88.900	-0.030	266.700	323.850	+0.053	50.800	76.200	-0.254
3.0000	3.5000	-0.0012	10.0000	18.0000	+0.0020	2.0000	3.0000	-0.0080	3.0000	3.5000	-0.0012	10.5000	12.7500	+0.0021	2.0000	3.0000	-0.0100
88.900	228.600	-0.038	457.200	660.400	+0.640	76.200	152.400	-0.254	88.900	228.600	-0.038	323.850	431.800	+0.058	76.200	152.400	-0.381
3.5000	9.0000	-0.0015	18.0000	26.0000	+0.0025	3.0000	6.0000	-0.0100	3.5000	9.0000	-0.0015	12.7500	17.0000	+0.0023	3.0000	6.0000	-0.0150
228.600	304.800	-0.046	660.400	863.600	+0.076	152.400	254.000	-0.381	228.600	304.800	-0.046	431.800	685.800	+0.064	152.400	254.000	-0.508
9.0000	12.0000	-0.0018	26.0000	34.0000	+0.0030	6.0000	10.0000	-0.0150	9.0000	12.0000	-0.0018	17.0000	27.0000	+0.0025	6.0000	10.0000	-0.0200
304.800	457.200	-0.051	863.600	1117.600	+0.102	254.000	457.200	-0.508	304.800	457.200	-0.051	685.800	889.000	+0.076	254.000	457.200	-0.635
12.0000	18.0000	-0.0020	34.0000	44.0000	+0.0040	10.0000	18.0000	-0.0200	12.0000	18.0000	-0.0020	27.0000	35.0000	+0.0030	10.0000	18.0000	-0.0250
457.200	558.800	-0.064				457.200	762.000	-0.635	457.200	558.800	-0.064				457.200	762.000	-0.762
18.0000	22.0000	-0.0025				18.0000	30.0000	-0.0250	18.0000	22.0000	-0.0025				18.0000	30.0000	-0.0300
558.800	762.000	-0.076							558.800	762.000	-0.076						
22.0000	30.0000	-0.0030							22.0000	30.0000	-0.0030						

The tolerances in this table conform to ANSI/ABMA Standard 21.2.



BEARING TOLERANCES, INCH & METRIC - *continued*

THRUST BALL BEARINGS																	
TYPE TVB						TYPES TVL & DTVL											
Bore			O.D.			Height			Bore			O.D.			Height		
Bearing over	Bore incl.	Tolerance -0	Bearing over	O.D. incl.	Tolerance +0.0	Bearing over	Bore incl.	Max.	Min.	Bearing over	Bore incl.	Tolerance -0	Bearing over	O.D. incl.	Tolerance +0.0	Bearing over	Tolerance
mm in.	mm in.	mm in.	mm in.	mm in.	mm in.	mm in.	mm in.	mm in.	mm in.	mm in.	mm in.	mm in.	mm in.	mm in.	mm in.	mm in.	mm in.
0.000	171.450	+0.127	0.000	134.938	-0.051	0.000	46.038	+0.127	-0.127	0.000	504.825	-0.076	0.000	584.000	-0.076		±.381
0.0000	6.7500	+0.0050	0.0000	5.3125	-0.0020	0.0000	1.8125	+0.0050	-0.0050	0.0000	19.8750	-0.0030	0.0000	23.0000	-0.0030	All Sizes	±.0150
171.450	508.000	+0.178	134.938	441.325	-0.076	46.038	304.800	+0.254	-0.254	504.825	1524.000	-0.127	584.000	1778.000	-0.127		
6.7500	20.0000	+0.0070	5.3125	17.3750	-0.0030	1.8125	12.0000	+0.0100	-0.0100	19.8750	60.0000	-0.0050	23.0000	70.0000	-0.0050		
			441.325	1000.000	-0.102	304.800	508.000	+0.381	-0.381								
			17.3750	39.3701	-0.0040	12.0000	20.0000	+0.0150	-0.0150								

The tolerances in this table conform to ANSI/ABMA Standard 2.

THRUST SPHERICAL ROLLER BEARINGS											
Inner Ring				Outer Ring				Height			
Bore		Tolerance		O.D.		Tolerance		Bore Diameter		Tolerance	
over	incl.	Bore	Radial Runout	over	incl.	O.D.	Radial Runout	over	incl.	plus	minus
mm in.	mm in.	-0.000 mm +0.0000	mm in.	mm in.	mm in.	mm in.	mm in.	mm in.	mm in.	mm in.	mm in.
80.000	120.000	-0.020	0.025	120.000	150.000	-0.020	0.041	80.000	120.000	0.094	0.254
3.1496	4.7244	-0.0008	0.0010	4.7244	5.9055	-0.0080	0.0016	3.1496	4.7244	0.0037	0.0100
120.000	180.000	-0.025	0.030	150.000	180.000	-0.025	0.046	120.000	180.000	0.109	0.300
4.7244	7.0866	-0.0010	0.0012	5.9055	7.0866	-0.0010	0.0018	4.7244	7.0866	0.0043	0.0118
180.000	250.000	-0.030	0.041	180.000	250.000	-0.030	0.051	180.000	250.000	0.130	0.366
7.0866	9.8425	-0.0012	0.0016	7.0866	9.8425	-0.0012	0.0020	7.0866	9.8425	0.0051	0.0144
250.000	315.000	-0.036	0.051	250.000	315.000	-0.036	0.061	250.000	315.000	0.155	0.434
9.8425	12.4016	-0.0014	0.0020	9.8425	12.4016	-0.0014	0.0024	9.8425	12.4016	0.0061	0.0171
315.000	400.000	-0.041	0.061	315.000	400.000	-0.041	0.071	315.000	400.000	0.170	0.480
12.4016	15.7480	-0.0016	0.0024	12.4016	15.7480	-0.0016	0.0028	12.4016	15.7480	0.0067	0.0189
400.000	500.000	-0.046	0.066	400.000	500.000	-0.046	0.081	400.000	500.000	0.185	0.526
15.7480	19.6850	-0.0018	0.0026	15.7480	19.6850	-0.0018	0.0032	15.7480	19.6850	0.0073	0.0207
500.000	630.000	-0.051	0.071	500.000	630.000	-0.051	0.102	500.000	630.000	0.203	0.584
19.6850	24.8031	-0.0020	0.0028	19.6850	24.8031	-0.0020	0.0040	19.6850	and up	0.0080	0.0230
630.000	800.000	-0.076	0.081	630.000	800.000	-0.076	0.119				
24.8031	31.4961	-0.0030	0.0032	24.8031	31.4961	-0.0030	0.0047				
800.000	1000.000	-0.102	0.089	800.000	1000.000	-0.102	0.140				
31.4961	39.3701	-0.0040	0.0035	31.4961	39.3701	-0.0040	0.0055				
1000.000	1250.000	-0.127	0.102	1000.000	1250.000	-0.127	0.163				
39.3701	49.2126	-0.0050	0.0040	39.3701	49.2126	-0.0050	0.0064				
			1250.000	1600.000	-0.165	0.193					
			49.2126	62.9921	-0.0065	0.0076					
			1600.000	2000.000	-0.203	0.229					
			62.9921	78.7402	-0.0080	0.009					

**TOLERANCES FOR NEEDLE ROLLER AND CAGE THRUST ASSEMBLIES**

Pages C234 to C237 list the nominal outside diameter, bore diameter and needle roller diameter for the FNT and AXK Series of needle roller and cage thrust assemblies and also the nominal outside diameter and bore diameter of the series AS, LS, WS and GS thrust washers. Thickness tolerances for the AS and LS thrust washers are also included.

Tolerances for the outside and bore diameters of series FNT and AXK needle roller and cage thrust assemblies are given in Table 12. The needle rollers in any one assembly have a group tolerance of 2 µm.

TABLE 12

TOLERANCES FOR BORE DIAMETER (D <sub>c1</sub> ) AND OUTSIDE DIAMETER (D <sub>c</sub> ) OF SERIES FNT AND AXK NEEDLE ROLLER AND CAGE THRUST ASSEMBLIES							
D <sub>c1</sub>		Deviations of min. bore dia. (E11)		D <sub>c</sub>		Deviations of max. outside dia. (c12)	
mm		µm		mm		µm	
>	≤	low	high	>	≤	high	low
3	6	+20	+95	18	30	-110	-320
6	10	+25	+115	30	40	-120	-370
10	18	+32	+142	40	50	-130	-380
18	30	+40	+170	50	65	-140	-440
30	50	+50	+210	65	80	-150	-450
50	80	+60	+250	80	100	-170	-520
80	120	+72	+292	100	120	-180	-530
				120	140	-200	-600

**Bore inspection procedure for assembly**

If an inspection of the bore diameter is desired, the bore diameter (D<sub>c1</sub>) of the assembly should be checked with “go” and “no go” plug gages. The “go” plug gage size is the minimum bore diameter of the assembly. The “no go” plug gage size is the maximum bore diameter of the assembly.

The assembly, under its own weight, must fall freely from the “go” plug gage. The “no go” plug gage must not enter the bore. Where the “no go” plug gage can be forced through the bore, the assembly must not fall from the gage under its own weight.

**Tolerances for thrust washers**

Tolerances for the outside and bore diameters of series AS thrust washers are given in Table 13. Thickness tolerance for series AS thrust washers is +0.05 mm.

TABLE 13

TOLERANCES FOR BORE DIAMETER (d) AND OUTSIDE DIAMETER (d <sub>1</sub> ) OF SERIES AS THRUST WASHERS.							
d		Deviations of min. bore dia. (E12)		d <sub>1</sub>		Deviations of max. outside dia. (e13)	
mm		µm		mm		µm	
>	≤	low	high	>	≤	high	low
3	6	+20	+140	18	30	-40	-370
6	10	+25	+175	30	50	-50	-440
10	18	+32	+212	50	80	-60	-520
18	30	+40	+250	80	120	-72	-612
30	50	+50	+300	120	180	-85	-715
50	80	+60	+360	180	250	-100	-820
80	120	+72	+422				
120	180	+85	+485				

Tolerances for the outside and bore diameters of series LS heavy thrust washers are given in Table 14. Thickness tolerances for series LS heavy thrust washers are given in tabular pages.

TABLE 14

TOLERANCES FOR BORE DIAMETER (d) AND OUTSIDE DIAMETER (d <sub>1</sub> ) OF SERIES LS HEAVY THRUST WASHERS.							
d		Deviations of min. bore dia. (E12)		d <sub>1</sub>		Deviations of max. outside dia. (a12)	
mm		µm		mm		µm	
>	≤	low	high	>	≤	high	low
3	6	+20	+140	18	30	-300	-510
6	10	+25	+175	30	40	-310	-560
10	18	+32	+212	40	50	-320	-570
18	30	+40	+250	50	65	-340	-640
30	50	+50	+300	65	80	-360	-660
50	80	+60	+360	80	100	-380	-730
80	120	+72	+422	100	120	-410	-760
120	180	+85	+485	120	140	-460	-860
				140	160	-520	-920
				160	180	-580	-980
				180	200	-660	-1120

**Bore inspection procedure for series AS and LS thrust washers**

If an inspection of the thrust washer bore diameter (d) is desired, it should be checked with “go” and “no go” plug gages. The “go” plug gage size is the minimum bore diameter of the thrust washer. The “no go” plug gage size is the maximum bore diameter of the thrust washer.

The thrust washer, under its own weight, must fall freely from the “go” plug gage. The “no go” plug gage must not enter the bore. Where the “no go” plug gage can be forced through the bore, the thrust washer must not fall from the gage under its own weight.



**BEARING TOLERANCES, INCH & METRIC - continued**

**TAPERED ROLLER BEARINGS**

Timken tapered roller bearings are manufactured to a number of specifications or “classes” that define tolerances on dimensions such as bore, O.D., width and runout. The Timken Company produces bearings to both inch and metric systems. The boundary dimension tolerances applicable to these two categories of bearings differ.

The major difference between the two tolerance systems is that inch bearings have historically been manufactured to positive bore and O.D. tolerances, whereas metric bearings have been manufactured to negative tolerances.

**Metric system bearings (ISO and “J” prefix parts)**

Timken manufactures metric system bearings to six tolerance classes. Classes K and N are often referred to as standard classes. Class N has more closely controlled bearing width tolerances than K. Classes C, B, A and AA are “precision” classes. These tolerances lie within those currently specified in ISO 492 with the exception of a small number of dimensions indicated in the tables. The differences normally have an insignificant effect on the mounting and performance of tapered roller bearings.

The following table illustrates the current ISO bearing class that corresponds approximately to each of The Timken Company metric bearing classes.

For the exact comparison, please consult your Timken representative.

BEARING CLASS						
Metric Inch	K 4	N 2	C 3	B 0	A 00	AA 000
ISO/DIN	Normal	6X	P5	P4	P2	–

METRIC BEARING TOLERANCES (µm)													
CONE BORE		Bearing Class											
		Standard				Precision				AA			
		K		N		C		B		A		AA	
Bearing types	Bore, mm over incl.	Max.	Min.	Max.	Min.	Max.	Min.	Max.	Min.	Max.	Min.	Max.	Min.
	10 18	0	-12	0	-12	0	-7	0	-5	0	-5	0	-5
	18 30	0	-12	0	-12	0	-8	0	-6	0	-6	0	-6
	30 50	0	-12	0	-12	0	-10	0	-8	0	-8	0	-8
	50 80	0	-15	0	-15	0	-12	0	-9	0	-8	0	-8
	80 120	0	-20	0	-20	0	-15	0	-10	0	-8	0	-8
TS	120 180	0	-25	0	-25	0	-18	0	-13	0	-8	0	-8
	180 250	0	-30	0	-30	0	-22	0	-15	0	-8	0	-8
TSF	250 265	0	-35	0	-35	0	-22	0	-15	0	-8	0	-8
	265 315	0	-35	0	-35	0	-22	0	-15	0	-8	0	-8
SR <sup>(1)</sup>	315 400	0	-40	0	-40	0	-25	–	–	–	–	–	–
	400 500	0	-45	0	-45	0	-25	–	–	–	–	–	–
	500 630	0	-50	–	–	0	-30	–	–	–	–	–	–
	630 800	0	-80	–	–	0	-40	–	–	–	–	–	–
	800 1000	0	-100	–	–	0	-50	–	–	–	–	–	–
	1000 1200	0	-130	–	–	0	-60	–	–	–	–	–	–
	1200 1600	0	-150	–	–	0	-80	–	–	–	–	–	–
	1600 2000	0	-200	–	–	–	–	–	–	–	–	–	–
2000	0	-250	–	–	–	–	–	–	–	–	–	–	

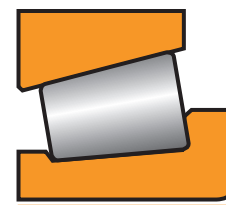

<sup>(1)</sup>SR assemblies are manufactured to tolerance class N only.

BEARING TOLERANCES, INCH & METRIC - continued

METRIC BEARING TOLERANCES (µm)													
CUP O.D.		Bearing Class											
		Standard				Precision				AA			
		K		N		C		B		A		AA	
Bearing types	O. D., mm over incl.	Max.	Min.	Max.	Min.	Max.	Min.	Max.	Min.	Max.	Min.	Max.	Min.
	10 18	-	-	-	-	-	-	-	-	0	-8	0	-8
	18 30	0	-12	0	-12	0	-8	0	-6	0	-8	0	-8
	30 50	0	-14	0	-14	0	-9	0	-7	0	-8	0	-8
	50 80	0	-16	0	-16	0	-11	0	-9	0	-8	0	-8
TS	80 120	0	-18	0	-18	0	-13	0	-10	0	-8	0	-8
	120 150	0	-20	0	-20	0	-15	0	-11	0	-8	0	-8
TSF	150 180	0	-25	0	-25	0	-18	0	-13	0	-8	0	-8
	180 250	0	-30	0	-30	0	-20	0	-15	0	-8	0	-8
SR <sup>(1)</sup>	250 265	0	-35	0	-35	0	-25	0	-18	0	-8	0	-8
	265 315	0	-35	0	-35	0	-25	0	-18	0	-8	0	-8
	315 400	0	-40	0	-40	0	-28	0	-18	-	-	-	-
	400 500	0	-45	0	-45	0	-30	-	-	-	-	-	-
	500 630	0	-50	0	-50	0	-35	-	-	-	-	-	-
	630 800	0	-80	-	-	0	-40	-	-	-	-	-	-
	800 1000	0	-100	-	-	0	-50	-	-	-	-	-	-
	1000 1200	0	-130	-	-	0	-60	-	-	-	-	-	-
	1200 1600	0	-165	-	-	0	-80	-	-	-	-	-	-
	1600 2000	0	-200	-	-	-	-	-	-	-	-	-	-
	2000	0	-250	-	-	-	-	-	-	-	-	-	-

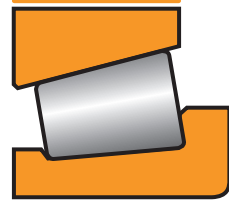

<sup>(1)</sup>SR assemblies are manufactured to tolerance class N only.

METRIC BEARING TOLERANCES (µm)													
CONE WIDTH		Bearing Class											
		Standard				Precision				AA			
		K		N		C		B		A		AA	
Bearing types	Bore, mm over incl.	Max.	Min.	Max.	Min.	Max.	Min.	Max.	Min.	Max.	Min.	Max.	Min.
	10 50	0	-100	0	-50	0	-200	0	-200	0	-200	0	-200
	50 120	0	-150	0	-50	0	-300	0	-300	0	-300	0	-300
TS	120 180	0	-200	0	-50	0	-300	0	-300	0	-300	0	-300
	180 250	0	-200	0	-50	0	-350	0	-350	0	-350	0	-350
TSF	250 265	0	-200	0	-50	0	-350	0	-350	0	-350	0	-350
	265 315	0	-200	0	-50	0	-350	0	-350	0	-350	0	-350
	315 500	0	-250	0	-50	0	-350	-	-	-	-	-	-
	500 630	0	-250	-	-	0	-350	-	-	-	-	-	-
	630 1200	0	-300	-	-	0	-350	-	-	-	-	-	-
	1200 1600	0	-350	-	-	0	-350	-	-	-	-	-	-
	1600	0	-350	-	-	-	-	-	-	-	-	-	-

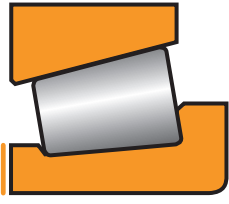





BEARING TOLERANCES, INCH & METRIC - continued

METRIC BEARING TOLERANCES (µm)													
CUP WIDTH		Bearing Class											
		Standard				Precision				AA			
		K		N		C		B		A		AA	
Bearing types	O. D., mm	Max.	Min.	Max.	Min.	Max.	Min.	Max.	Min.	Max.	Min.	Max.	Min.
	over incl.												
	10 80	0	-150	0	-100	0	-150	0	-150	0	-150	0	-150
	80 150	0	-200	0	-100	0	-200	0	-200	0	-200	0	-200
	150 180	0	-200	0	-100	0	-250	0	-250	0	-250	0	-250
	180 250	0	-250	0	-100	0	-250	0	-250	0	-250	0	-250
TS	250 265	0	-250	0	-100	0	-300	0	-300	0	-300	0	-300
	265 315	0	-250	0	-100	0	-300	0	-300	0	-300	0	-300
TSF	315 400	0	-250	0	-100	0	-300	0	-300	-	-	-	-
	400 500	0	-300	0	-100	0	-350	-	-	-	-	-	-
	500 800	0	-300	0	-100	0	-350	-	-	-	-	-	-
	800 1200	0	-350	-	-	0	-400	-	-	-	-	-	-
	1200 1600	0	-400	-	-	0	-400	-	-	-	-	-	-
	1600	0	-400	-	-	-	-	-	-	-	-	-	-

▲These differ slightly from tolerances in ISO 492. These differences normally have an insignificant effect on the mounting and performance of tapered roller bearings. The 30000 series ISO bearings are also available with the above parameter according to ISO 492.

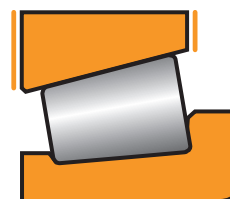

METRIC BEARING TOLERANCES (µm)													
CONE STAND		Bearing Class											
		Standard				Precision				AA			
		K		N		C		B		A		AA	
Bearing types	Bore, mm	Max.	Min.	Max.	Min.	Max.	Min.	Max.	Min.	Max.	Min.	Max.	Min.
	over incl.												
	10 80	+100	0	+50	0	+100	-100	*	*	*	*	*	*
	80 120	+100	-100	+50	0	+100	-100	*	*	*	*	*	*
TS	120 180	+150	-150	+50	0	+100	-100	*	*	*	*	*	*
	180 250	+150	-150	+50	0	+100	-150	*	*	*	*	*	*
	250 265	+150	-150	+100	0	+100	-150	*	*	*	*	*	*
TSF	265 315	+150	-150	+100	0	+100	-150	*	*	-	-	-	-
	315 400	+200	-200	+100	0	+150	-150	-	-	-	-	-	-
	400	*	*	*	*	*	*	-	-	-	-	-	-

\* These sizes manufactured as matched assemblies only.

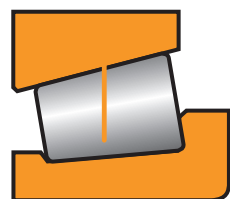

Cone Stand. Cone stand is a measure of the variation in cone raceway size and taper and roller diameter and taper which is checked by measuring the axial location of the reference surface of a master cup or other type gage with respect to the reference face of the cone.

METRIC BEARING TOLERANCES (µm)													
CUP STAND		Bearing Class											
		Standard				Precision				AA			
		K		N		C		B		A		AA	
Bearing types	Bore, mm	Max.	Min.	Max.	Min.	Max.	Min.	Max.	Min.	Max.	Min.	Max.	Min.
	over incl.												
	10 18	+100	0	+50	0	+100	-100	*	*	*	*	*	*
	18 80	+100	0	+50	0	+100	-100	*	*	*	*	*	*
TS	80 120	+100	-100	+50	0	+100	-100	*	*	*	*	*	*
	120 265	+200	-100	+100	0	+100	-150	*	*	*	*	*	*
	265 315	+200	-100	+100	0	+100	-150	*	*	-	-	-	-
TSF <sup>(1)</sup>	315 400	+200	-200	+100	0	+100	-150	-	-	-	-	-	-
	400	*	*	*	*	*	*	-	-	-	-	-	-

\* These sizes manufactured as matched assemblies only.

<sup>(1)</sup>Stand for flanged cup is measured from flange backface (seating face).

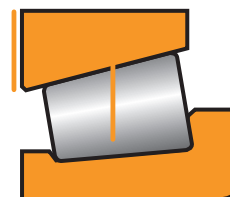

Cup Stand. Cup stand is a measure of the variation in cup I.D. size and taper which is checked by measuring the axial location of the reference surface of a master plug or other type gage with respect to the reference face of the cup.

BEARING TOLERANCES, INCH & METRIC - continued

METRIC BEARING TOLERANCES (µm)														
OVERALL BEARING WIDTH		Bearing Class												
		Standard						Precision						
		K		N		C		B		A		AA		
Bearing types	Bore, mm over incl.	Max.	Min.	Max.	Min.	Max.	Min.	Max.	Min.	Max.	Min.	Max.	Min.	
TS	10 80	+200	0	+100	0	+200	-200	+200	-200	+200	-200	+200	-200	
	80 120	+200	-200	+100	0	+200	-200	+200	-200	+200	-200	+200	-200	
	120 180	+350	-250	+150	0	+350	-250	+200	-250	+200	-250	+200	-250	
	180 250	+350	-250	+150	0	+350	-250	+200	-300	+200	-300	+200	-300	
	250 265	+350	-250	+200	0	+350	-300	+200	-300	+200	-300	+200	-300	
	265 315	+350	-250	+200	0	+350	-300	+200	-300	+200	-300	+200	-300	
	TSF <sup>(2)</sup>	315 500	+400	-400	+200	0	+350	-300	-	-	-	-	-	-
		500 800	+400	-400	-	-	+350	-400	-	-	-	-	-	-
		800 1000	+450	-450	-	-	+350	-400	-	-	-	-	-	-
		1000 1200	+450	-450	-	-	+350	-450	-	-	-	-	-	-
SR <sup>(3)</sup>	1200 1600	+450	-450	-	-	+350	-500	-	-	-	-	-	-	
	1600	+450	-450	-	-	-	-	-	-	-	-	-	-	
SR <sup>(3)</sup>	10 500	-	-	0	-150	-	-	-	-	-	-	-	-	

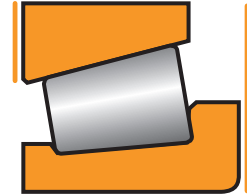

<sup>(2)</sup> For bearing type TSF the tolerance applies to the dimension T<sub>1</sub>.  
<sup>(3)</sup> SR assemblies are manufactured to tolerance class N only.

METRIC BEARING TOLERANCES (µm)												
ASSEMBLED BEARING MAXIMUM RADIAL RUNOUT		Bearing Class										
		Standard				Precision						
		K		N		C		B		A		AA
Bearing types	O.D., mm over incl.											
TS	10 18	-	-	-	-	1.9	1					
	18 30	18	18	5	3	1.9	1					
	30 50	20	20	6	3	1.9	1					
	50 80	25	25	6	4	1.9	1					
	80 120	35	35	6	4	1.9	1					
	120 150	40	40	7	4	1.9	1					
	150 180	45	45	8	4	1.9	1					
	180 250	50	50	10	5	1.9	1					
	250 265	60	60	11	5	1.9	1					
	265 315	60	60	11	5	1.9	1					
TSF	315 400	70	70	13	5	-	-					
	400 500	80	80	18	-	-	-					
SR <sup>(1)</sup>	500 630	100	-	25	-	-	-					
	630 800	120	-	35	-	-	-					
	800 1000	140	-	50	-	-	-					
	1000 1200	160	-	60	-	-	-					
	1200 1600	180	-	80	-	-	-					
	1600 2000	200	-	-	-	-	-					
	2000	200	-	-	-	-	-					

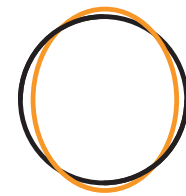

<sup>(1)</sup> SR assemblies are manufactured to tolerance class N only.

BEARING TOLERANCES, INCH & METRIC - *continued*

**INCH SYSTEM BEARINGS**

Inch system bearings are manufactured to a number of tolerance classes. Classes 4 and 2 are often referred to as “standard” classes.

Class 2 has certain tolerances more closely controlled than class 4 and thus may be required for specific applications. Classes 3, 0, 00 and 000 are “precision” classes.

INCH BEARING TOLERANCES (µm AND 0.0001 INCH)														
CONE BORE		Bearing Class												
		Standard				Precision				000				
		4		2		3		0		00		000		
Bearing types	Bore, mm (in.) over incl.		Max.	Min.	Max.	Min.	Max.	Min.	Max.	Min.	Max.	Min.	Max.	Min.
	0	76.200	+13	0	+13	0	+13	0	+13	0	+8	0	+8	0
	0	3.0000	+5	0	+5	0	+5	0	+5	0	+3	0	+3	0
TS	76.200	304.800	+25	0	+25	0	+13	0	+13	0	+8	0	+8	0
TSF	3.0000	12.0000	+10	0	+10	0	+5	0	+5	0	+3	0	+3	0
TSL <sup>(1)</sup>	304.800	609.600	-	-	+51	0	+25	0	-	-	-	-	-	-
	12.0000	24.0000	-	-	+20	0	+10	0	-	-	-	-	-	-
SS	609.600	914.400	+76	0	-	-	+38	0	-	-	-	-	-	-
TDI	24.0000	36.0000	+30	0	-	-	+15	0	-	-	-	-	-	-
TDIT	914.400	1219.200	+102	0	-	-	+51	0	-	-	-	-	-	-
TDO	36.0000	48.0000	+40	0	-	-	+20	0	-	-	-	-	-	-
TNA	1219.200	48.0000	+127	0	-	-	+76	0	-	-	-	-	-	-
			+50	0	-	-	+30	0	-	-	-	-	-	-

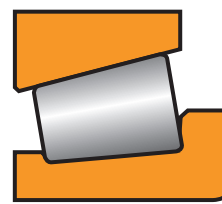

<sup>(1)</sup> For TSL bearings these are the normal tolerances of cone bore. However, bore size can be slightly reduced at large end due to tight fit assembly of the seal on the rib. This should not have any effect on the performance of the bearing.

INCH BEARING TOLERANCES (µm AND 0.0001 INCH)														
CUP O.D.		Bearing Class												
		Standard				Precision				000				
		4		2		3		0		00		000		
Bearing types	Bore, mm (in.) over incl.		Max.	Min.	Max.	Min.	Max.	Min.	Max.	Min.	Max.	Min.	Max.	Min.
TS	0	304.800	+25	0	+25	0	+13	0	+13	0	+8	0	+8	0
TSF	0	12.0000	+10	0	+10	0	+5	0	+5	0	+3	0	+3	0
TSL	304.800	609.600	+51	0	+51	0	+25	0	-	-	-	-	-	-
SS	12.0000	24.0000	+20	0	+20	0	+10	0	-	-	-	-	-	-
TDI	609.600	914.400	+76	0	+76	0	+38	0	-	-	-	-	-	-
TDIT	24.0000	36.0000	+30	0	+30	0	+15	0	-	-	-	-	-	-
TDO	914.400	1219.200	+102	0	-	-	+51	0	-	-	-	-	-	-
TNA	36.0000	48.0000	+40	0	-	-	+20	0	-	-	-	-	-	-
TNASW	1219.200		+127	0	-	-	+76	0	-	-	-	-	-	-
TNASWE	48.0000		+50	0	-	-	+30	0	-	-	-	-	-	-

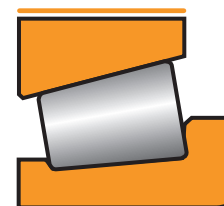

**INCH BEARING TOLERANCES (µm AND 0.0001 INCH)**

OUTER RACE FLANGE O.D.		Bearing Class												
		Standard				Precision								
		4		2		3		0		00		000		
Bearing types	O.D., mm (in.) over      incl.		Max.	Min.	Max.	Min.	Max.	Min.	Max.	Min.	Max.	Min.	Max.	Min.
	TSF	304.800 12.0000	609.600 24.0000	+51	0	+52	0	+51	0	+51	0	+51	0	+51
+20				0	+20	0	+20	0	+20	0	+20	0	+20	0
609.600 24.0000		914.400 36.0000	+76	0	+76	0	+76	0	-	-	-	-	-	-
			+30	0	+30	0	+30	0	-	-	-	-	-	-
914.400 36.0000			+102	0	+102	0	+102	0	-	-	-	-	-	-
			+40	0	+40	0	+40	0	-	-	-	-	-	-
		+127	0	-	-	+127	0	-	-	-	-	-	-	
		+40	0	-	-	+50	0	-	-	-	-	-	-	

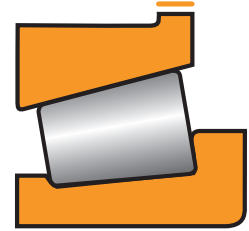

**INCH BEARING TOLERANCES (µm AND 0.0001 INCH)**

INNER RACE WIDTH		Bearing Class												
		Standard				Precision								
		4		2		3		0		00		000		
Bearing types	O.D., mm (in.) over      incl.		Max.	Min.	Max.	Min.	Max.	Min.	Max.	Min.	Max.	Min.	Max.	Min.
	TS TSF TSL SS TDI TDIT TDO	All Sizes		+76	-254	+76	-254	+76	-254	+76	-254	+76	-254	+76
			+30	-100	+30	-100	+30	-100	+30	-100	+30	-100	+30	-100

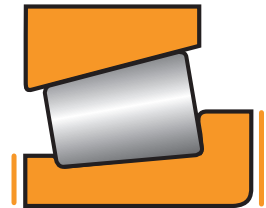

**INCH BEARING TOLERANCES (µm AND 0.0001 INCH)**

OUTER RACE WIDTH		Bearing Class												
		Standard				Precision								
		4		2		3		0		00		000		
Bearing types	O.D., mm (in.) over      incl.		Max.	Min.	Max.	Min.	Max.	Min.	Max.	Min.	Max.	Min.	Max.	Min.
	All Types	All Sizes		+51	-254	+51	-254	+51	-254	+51	-254	+51	-254	+51
			+20	-100	+20	-100	+20	-100	+20	-100	+20	-100	+20	-100

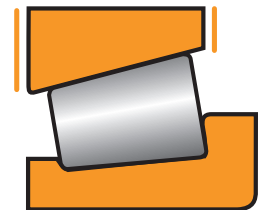



BEARING TOLERANCES, INCH & METRIC - continued

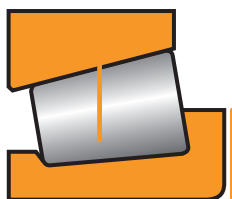

Cone Stand. Cone stand is a measure of the variation in cone raceway size and taper and roller diameter and taper which is checked by measuring the axial location of the reference surface of a master cup or other type gage with respect to the reference face of the cone.

INCH BEARING TOLERANCES (µm AND 0.0001 INCH)														
CONE STAND		Bearing Class												
		Standard						Precision						
		4		2		3		0		00		000		
Bearing types	O.D., mm (in.) over incl.		Max.	Min.	Max.	Min.	Max.	Min.	Max.	Min.	Max.	Min.	Max.	Min.
	0	101.600	+102	0	+102	0	+102	-102	*	*	*	*	*	*
	0	4.0000	+40	0	+40	0	+40	-40	*	*	*	*	*	*
TS	101.600	266.700	+152	-152	+102	0	+102	-102	*	*	*	*	*	*
TSL	4.0000	10.5000	+60	-60	+40	0	+40	-40	*	*	*	*	*	*
SS	266.700	304.800	+152	-152	+102	0	+102	-102	*	*	-	-	-	-
TDI <sup>(1)</sup>	10.5000	12.0000	+60	-60	+40	0	+40	-40	*	*	-	-	-	-
TDIT <sup>(1)</sup>	304.800	406.400	-	-	+178	-178	+102	-102	-	-	-	-	-	-
TDO	12.0000	16.0000	-	-	+70	-70	+40	-40	-	-	-	-	-	-
	406.400	16.0000	*	*	*	*	*	*	-	-	-	-	-	-
			*	*	*	*	*	*	-	-	-	-	-	-

\* These sizes manufactured as matched assemblies only.

<sup>(1)</sup> For class 2, TDI and TDIT bearings with cone bore of 101.600 to 304.800 mm (4 in. to 12 in.), the cone stand is ±102 (±40).

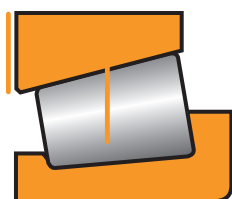

Cup Stand. Cup stand is a measure of the variation in cup I.D. size and taper which is checked by measuring the axial location of the reference surface of a master plug or other type gage with respect to the reference face of the cup.

INCH BEARING TOLERANCES (µm AND 0.0001 INCH)														
CUP STAND		Bearing Class												
		Standard						Precision						
		4		2		3		0		00		000		
Bearing types	Bore, mm (in.) over incl.		Max.	Min.	Max.	Min.	Max.	Min.	Max.	Min.	Max.	Min.	Max.	Min.
	0	101.600	+102	0	+102	0	+102	-102	*	*	*	*	*	*
	0	4.0000	+40	0	+40	0	+40	-40	*	*	*	*	*	*
TS	101.600	266.700	+203	-102	+102	0	+102	-102	*	*	*	*	*	*
TSF <sup>(1)</sup>	4.0000	10.5000	+80	-40	+40	0	+40	-40	*	*	*	*	*	*
TSL	266.700	304.800	+203	-102	+102	0	+102	-102	*	*	-	-	-	-
SS	10.5000	12.0000	+80	-40	+40	0	+40	-40	*	*	-	-	-	-
TDI	304.800	406.400	-	-	+203	-203	+102	-102	-	-	-	-	-	-
TDIT	12.0000	16.0000	-	-	+80	-80	+40	-40	-	-	-	-	-	-
	406.400	16.0000	*	*	*	*	*	*	-	-	-	-	-	-
			*	*	*	*	*	*	-	-	-	-	-	-

\* These sizes manufactured as matched assemblies only.

<sup>(1)</sup> Stand for flanged cup is measured from flange backface (seating face).

INCH BEARING TOLERANCES (µm AND 0.0001 INCH)																
OVERALL BEARING WIDTH			Bearing Class													
			Standard				Precision									
Bearing types	Bore, mm (in.)		O.D., mm (in.)		4		2		3		0		00		000	
	over	incl.	over	incl.	Max.	Min.	Max.	Min.	Max.	Min.	Max.	Min.	Max.	Min.	Max.	Min.
TS	0	101.600	-	-	+203	0	+203	0	+203	-203	+203	-203	+203	-203	+203	-203
	0	4.0000	-	-	+80	0	+80	0	+80	-80	+80	-80	+80	-80	+80	-80
	101.600	304.800	-	-	+356	-254	+203	0	+203	-203	+203	-203	+203	-203	+203	-203
	4.0000	12.0000	-	-	+140	-100	+80	0	+80	-80	+80	-80	+80	-80	+80	-80
	304.800	609.600	0	508.000	-	-	+381	-381	+203	-203	-	-	-	-	-	-
	12.0000	24.0000	0	20.0000	-	-	+150	-150	+80	-80	-	-	-	-	-	-
TSF <sup>(1)</sup>	304.800	609.600	0	508.000	-	-	+381	-381	+203	-203	-	-	-	-	-	-
	12.0000	24.0000	0	20.0000	-	-	+150	-150	+80	-80	-	-	-	-	-	-
	304.800	609.600	508.000	-	-	-	-	+381	-381	+381	-381	-	-	-	-	-
	12.0000	24.0000	20.0000	-	-	-	-	+150	-150	+150	-150	-	-	-	-	-
	609.600	-	-	-	-	+381	-381	-	-	+381	-381	-	-	-	-	-
	24.0000	-	-	-	-	+150	-150	-	-	+150	-150	-	-	-	-	-
TNA	0	127.000	-	-	-	-	+254	0	+254	0	-	-	-	-	-	-
	0	5.0000	-	-	-	-	+100	0	+100	0	-	-	-	-	-	-
	127.000	-	-	-	-	-	+762	0	+762	0	-	-	-	-	-	-
TNASW	0	101.600	-	-	+406	0	+406	0	+406	-406	+406	-406	+406	-406	+406	-406
	0	4.0000	-	-	+160	0	+160	0	+160	-160	+160	-160	+160	-160	+160	-160
	101.600	304.800	-	-	+711	-508	+406	-203	+406	-406	+406	-406	+406	-406	+406	-406
TDI	4.0000	12.0000	-	-	+280	-200	+160	-80	+160	-160	+160	-160	+160	-160	+160	-160
	304.800	609.600	0	508.000	-	-	+762	-762	+406	-406	-	-	-	-	-	-
	12.0000	24.0000	0	20.0000	-	-	+300	-300	+160	-160	-	-	-	-	-	-
	304.800	609.600	508.000	-	-	-	-	+762	-762	+762	-762	-	-	-	-	-
	12.0000	24.0000	20.0000	-	-	-	-	+300	-300	+300	-300	-	-	-	-	-
	609.600	-	-	-	-	+762	-762	-	-	+762	-762	-	-	-	-	-
SS	0	101.600	-	-	+457	-51	+457	-51	-	-	-	-	-	-	-	-
	0	4.0000	-	-	+180	-20	+180	-20	-	-	-	-	-	-	-	-

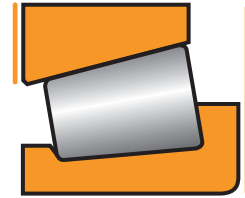

(1) For bearing type TSF the tolerance applies to the dimension T<sub>1</sub>.

INCH BEARING TOLERANCES (µm AND 0.0001 INCH)														
ASSEMBLED BEARING MAXIMUM RADIAL RUNOUT			Bearing Class											
			Standard				Precision							
Bearing types	O.D., mm (in.)		4		2		3		0		00		000	
	over	incl.	Max.	Min.	Max.	Min.	Max.	Min.	Max.	Min.	Max.	Min.	Max.	Min.
TS	0	-	51	-	38	-	8	-	4	-	2	-	1	-
TSF	0	-	20	-	15	-	3	-	1.5	-	0.75	-	0.40	-
TSL	266.700	304.800	51	-	38	-	8	-	4	-	2	-	1	-
	10.5000	12.0000	20	-	15	-	3	-	1.5	-	0.75	-	0.40	-
SS	304.800	609.600	51	-	38	-	18	-	-	-	-	-	-	-
	12.0000	24.0000	20	-	15	-	7	-	-	-	-	-	-	-
TDI	609.600	914.400	76	-	51	-	51	-	-	-	-	-	-	-
TDO	24.0000	36.0000	30	-	20	-	20	-	-	-	-	-	-	-
TNA	914.400	-	76	-	-	-	76	-	-	-	-	-	-	-
TNASW	36.0000	-	30	-	-	-	30	-	-	-	-	-	-	-







BEARING TOLERANCES, INCH & METRIC - *continued*

**THRUST TAPERED ROLLER BEARING (TTHD, TTVF, TTVS)  
TOLERANCES (µm AND 0.0001in.)**

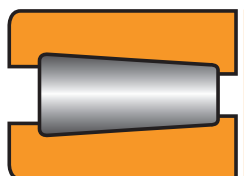

BORE		BEARING CLASS			
Range, mm (in.)		Standard 2		Precision 3	
over	incl.	Max.	Min.	Max.	Min.
0	304.800	+25	0	+13	0
0	12.0000	+10	0	+5	0
304.800	609.600	+51	0	+25	0
12.0000	24.0000	+20	0	+10	0
609.600	914.400	+76	0	+38	0
24.0000	36.0000	+30	0	+15	0
914.400	1219.200	+102	0	+51	0
36.0000	48.0000	+40	0	+20	0
1219.200		+127	0	+76	0
48.0000		+50	0	+30	0

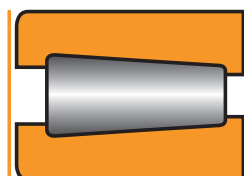

OUTSIDE DIAMETER		BEARING CLASS			
Range, mm (in.)		Standard 2		Precision 3	
over	incl.	Max.	Min.	Max.	Min.
0	304.800	+25	0	+13	0
0	12.0000	+10	0	+5	0
304.800	609.600	+51	0	+25	0
12.0000	24.0000	+20	0	+10	0
609.600	914.400	+76	0	+38	0
24.0000	36.0000	+30	0	+15	0
914.400	1219.200	+102	0	+51	0
36.0000	48.0000	+40	0	+20	0
1219.200		+127	0	+76	0
48.0000		+50	0	+30	0

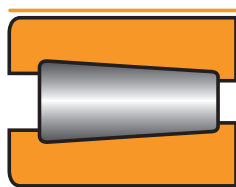

WIDTH	BEARING CLASS			
	Standard 2		Precision 3	
	Max.	Min.	Max.	Min.
All sizes	+381 +150	-381 -150	+203 +80	-203 -80

BEARING TOLERANCES, INCH & METRIC - *continued*

**THRUST TAPERED ROLLER BEARING (TTC, TTSP – CLASS 4)  
TOLERANCES (µm AND 0.0001 inch)**

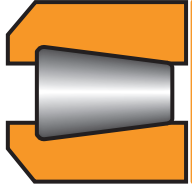

BORE		DEVIATION	
Range, mm (in.)			
over	incl.	Max.	Min.
0	25.400	+76	-76
0	1.0000	+30	-30
25.400	76.200	+102	-102
1.0000	3.0000	+40	-40
76.200		+127	-127
3.0000		+50	-50

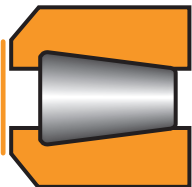

OUTSIDE DIAMETER		DEVIATION	
Range, mm (in.)			
over	incl.	Max.	Min.
0	127.000	+254	0
0	5.0000	+100	0
127.000	203.200	+381	0
5.0000	8.0000	+150	0
203.200		+508	0
8.0000		+200	0



WIDTH		DEVIATION	
Range, mm (in.)			
over	incl.	Max.	Min.
0	76.200	+254	-254
0	3.0000	+100	-100
76.200	127.000	+381	-381
3.0000	5.0000	+150	-150
127.000		+508	-508
5.0000		+200	-200



**BEARING TOLERANCES, INCH & METRIC - continued**

The following tables provide standard ISO tolerance information. They are provided for general use and are referenced throughout this catalog.

ISO TOLERANCES FOR HOLES – METRIC													
Diameters mm		Deviations in $\mu\text{m}$						Deviations in $\mu\text{m}$					
		B10		B11		B12		C9		C10		C11	
>	$\leq$	high	low	high	low	high	low	high	low	high	low	high	low
3	6	+188	+140	+215	+140	+260	+140	+100	+70	+118	+70	+145	+70
6	10	+208	+150	+240	+150	+300	+150	+116	+80	+138	+80	+170	+80
10	18	+220	+150	+260	+150	+330	+150	+138	+95	+165	+95	+205	+95
18	30	+244	+160	+290	+160	+370	+160	+162	+110	+194	+110	+240	+110
30	40	+270	+170	+330	+170	+420	+170	+182	+120	+220	+120	+280	+120
40	50	+280	+180	+340	+180	+430	+180	+192	+130	+230	+130	+290	+130
50	65	+310	+190	+380	+190	+490	+190	+214	+140	+260	+140	+330	+140
65	80	+320	+200	+390	+200	+500	+200	+224	+150	+270	+150	+340	+150
80	100	+360	+220	+440	+220	+570	+220	+257	+170	+310	+170	+390	+170
100	120	+380	+240	+460	+240	+590	+240	+267	+180	+320	+180	+400	+180
120	140	+420	+260	+510	+260	+660	+260	+300	+200	+360	+200	+450	+200
140	160	+440	+280	+530	+280	+680	+280	+310	+210	+370	+210	+460	+210
160	180	+470	+310	+560	+310	+710	+310	+330	+230	+390	+230	+480	+230
180	200	+525	+340	+630	+340	+800	+340	+355	+240	+425	+240	+530	+240
200	225	+565	+380	+670	+380	+840	+380	+375	+260	+445	+260	+550	+260
225	250	+605	+420	+710	+420	+880	+420	+395	+280	+465	+280	+570	+280
250	280	+690	+480	+800	+480	+1000	+480	+430	+300	+510	+300	+620	+300
280	315	+750	+540	+860	+540	+1060	+540	+460	+330	+540	+330	+650	+330
315	355	+830	+600	+960	+600	+1170	+600	+500	+360	+590	+360	+720	+360
355	400	+910	+680	+1040	+680	+1250	+680	+540	+400	+630	+400	+760	+400
400	450	+1010	+760	+1160	+760	+1390	+760	+595	+440	+690	+440	+840	+440
450	500	+1090	+840	+1240	+840	+1470	+840	+635	+480	+730	+480	+880	+480

Diameters mm		Deviations in $\mu\text{m}$									
		E9		E10		E11		E12		E13	
>	$\leq$	high	low	high	low	high	low	high	low	high	low
3	6	+50	+20	+68	+20	+95	+20	+140	+20	+200	+20
6	10	+61	+25	+83	+25	+115	+25	+175	+25	+245	+25
10	18	+75	+32	+102	+32	+142	+32	+212	+32	+302	+32
18	30	+92	+40	+124	+40	+170	+40	+250	+40	+370	+40
30	50	+112	+50	+150	+50	+210	+50	+300	+50	+440	+50
50	80	+134	+60	+180	+60	+250	+60	+360	+60	+520	+60
80	120	+159	+72	+212	+72	+292	+72	+422	+72	+612	+72
120	180	+185	+85	+245	+85	+335	+85	+485	+85	+715	+85
180	250	+215	+100	+285	+100	+390	+100	+560	+100	+820	+100
250	315	+240	+110	+320	+110	+430	+110	+630	+110	+920	+110
315	400	+265	+125	+355	+125	+485	+125	+695	+125	+1015	+125
400	500	+290	+135	+385	+135	+535	+135	+765	+135	+1105	+135

Diameters mm		Deviations in $\mu\text{m}$							
		F5		F6		F7		F8	
>	$\leq$	high	low	high	low	high	low	high	low
3	6	+15	+10	+18	+10	+22	+10	+28	+10
6	10	+19	+13	+22	+13	+28	+13	+35	+13
10	18	+24	+16	+27	+16	+34	+16	+43	+16
18	30	+29	+20	+33	+20	+41	+20	+53	+20
30	50	+36	+25	+41	+25	+50	+25	+64	+25
50	80	+43	+30	+49	+30	+60	+30	+76	+30
80	120	+51	+36	+58	+36	+71	+36	+90	+36
120	180	+61	+43	+68	+43	+83	+43	+106	+43
180	250	+70	+50	+79	+50	+96	+50	+122	+50
250	315	+79	+56	+88	+56	+108	+56	+137	+56
315	400	+87	+62	+98	+62	+119	+62	+151	+62
400	500	+95	+68	+108	+68	+131	+68	+165	+68

ISO TOLERANCES FOR HOLES – METRIC									
Diameters mm		Deviations in $\mu\text{m}$							
		G5		G6		G7			
>	$\leq$	high	low	high	low	high	low	high	low
3	6	+9	+4	+12	+4	+16	+4		
6	10	+11	+5	+14	+5	+20	+5		
10	18	+14	+6	+17	+6	+24	+6		
18	30	+16	+7	+20	+7	+28	+7		
30	50	+20	+9	+25	+9	+34	+9		
50	80	+23	+10	+29	+10	+40	+10		
80	120	+27	+12	+34	+12	+47	+12		
120	180	+32	+14	+39	+14	+54	+14		
180	250	+35	+15	+44	+15	+61	+15		
250	315	+40	+17	+49	+17	+69	+17		
315	400	+43	+18	+54	+18	+75	+18		
400	500	+47	+20	+60	+20	+83	+20		

Deviations in $\mu\text{m}$											
Diameters mm		H4		H5		H6		H7		H8	
		high	low	high	low	high	low	high	low	high	low
3	6	+4	0	+5	0	+8	0	+12	0	+18	0
6	10	+4	0	+6	0	+9	0	+15	0	+22	0
10	18	+5	0	+8	0	+11	0	+18	0	+27	0
18	30	+6	0	+9	0	+13	0	+21	0	+33	0
30	50	+7	0	+11	0	+16	0	+25	0	+39	0
50	80	+8	0	+13	0	+19	0	+30	0	+46	0
80	120	+10	0	+15	0	+22	0	+35	0	+54	0
120	180	+12	0	+18	0	+25	0	+40	0	+63	0
180	250	+14	0	+20	0	+29	0	+46	0	+72	0
250	315	+16	0	+23	0	+32	0	+52	0	+81	0
315	400	+18	0	+25	0	+36	0	+57	0	+89	0
400	500	+20	0	+27	0	+40	0	+63	0	+97	0

Deviations in $\mu\text{m}$											
Diameters mm		H9		H10		H11		H12			
		high	low	high	low	high	low	high	low		
3	6	+30	0	+48	0	+75	0	+120	0		
6	10	+36	0	+58	0	+90	0	+150	0		
10	18	+43	0	+70	0	+110	0	+180	0		
18	30	+52	0	+84	0	+130	0	+210	0		
30	50	+62	0	+100	0	+160	0	+250	0		
50	80	+74	0	+120	0	+190	0	+300	0		
80	120	+87	0	+140	0	+220	0	+350	0		
120	180	+100	0	+160	0	+250	0	+400	0		
180	250	+115	0	+185	0	+290	0	+460	0		
250	315	+130	0	+210	0	+320	0	+520	0		
315	400	+140	0	+230	0	+360	0	+570	0		
400	500	+155	0	+250	0	+400	0	+630	0		



BEARING TOLERANCES, INCH & METRIC - continued

ISO TOLERANCES FOR HOLES – METRIC													
Diameters mm		Deviations in $\mu\text{m}$						Deviations in $\mu\text{m}$					
		J6		J7		J8		K6		K7		K8	
>	$\leq$	high	low	high	low	high	low	high	low	high	low	high	low
3	6	+5	-3	+6	-6	+10	-8	+2	-6	+3	-9	+5	-13
6	10	+5	-4	+8	-7	+12	-10	+2	-7	+5	-10	+6	-16
10	18	+6	-5	+10	-8	+15	-12	+2	-9	+6	-12	+8	-19
18	30	+8	-5	+12	-9	+20	-13	+2	-11	+6	-15	+10	-23
30	50	+10	-6	+14	-11	+24	-15	+3	-13	+7	-18	+12	-27
50	80	+13	-6	+18	-12	+28	-18	+4	-15	+9	-21	+14	-32
80	120	+16	-6	+22	-13	+34	-20	+4	-18	+10	-25	+16	-38
120	180	+18	-7	+26	-14	+41	-22	+4	-21	+12	-28	+20	-43
180	250	+22	-7	+30	-16	+47	-25	+5	-24	+13	-33	+22	-50
250	315	+25	-7	+36	-16	+55	-26	+5	-27	+16	-36	+25	-56
315	400	+29	-7	+39	-18	+60	-29	+7	-29	+17	-40	+28	-61
400	500	+33	-7	+43	-20	+66	-31	+8	-32	+18	-45	+29	-68

ISO TOLERANCES FOR HOLES – METRIC													
Diameters mm		Deviations in $\mu\text{m}$						Deviations in $\mu\text{m}$					
		M5		M6		M7		N6		N7		N8	
>	$\leq$	high	low	high	low	high	low	high	low	high	low	high	low
3	6	-3	-8	-1	-9	0	-12	-5	-13	-4	-16	-2	-20
6	10	-4	-10	-3	-12	0	-15	-7	-16	-4	-19	-3	-25
10	18	-4	-12	-4	-15	0	-18	-9	-20	-5	-23	-3	-30
18	30	-5	-14	-4	-17	0	-21	-11	-24	-7	-28	-3	-36
30	50	-5	-16	-4	-20	0	-25	-12	-28	-8	-33	-3	-42
50	80	-6	-19	-5	-24	0	-30	-14	-33	-9	-39	-4	-50
80	120	-8	-23	-6	-28	0	-35	-16	-38	-10	-45	-4	-58
120	180	-9	-27	-8	-33	0	-40	-20	-45	-12	-52	-4	-67
180	250	-11	-31	-8	-37	0	-46	-22	-51	-14	-60	-5	-77
250	315	-13	-36	-9	-41	0	-52	-25	-57	-14	-66	-5	-86
315	400	-14	-39	-10	-46	0	-57	-26	-62	-16	-73	-5	-94
400	500	-16	-43	-10	-50	0	-63	-27	-67	-17	-80	-6	-103

ISO TOLERANCES FOR HOLES – METRIC												
Diameters mm		Deviations in $\mu\text{m}$						Deviations in $\mu\text{m}$				
		P6		P7		R6		R7		R8		
>	$\leq$	high	low	high	low	high	low	high	low	high	low	
3	6	-9	-17	-8	-20	-12	-20	-11	-23	-15	-33	
6	10	-12	-21	-9	-24	-16	-25	-13	-28	-19	-41	
10	18	-15	-26	-11	-29	-20	-31	-16	-34	-23	-50	
18	30	-18	-31	-14	-35	-24	-37	-20	-41	-28	-61	
30	50	-21	-37	-17	-42	-29	-45	-25	-50	-34	-73	
50	65	-26	-45	-21	-51	-35	-54	-30	-60	-41	-87	
65	80	-26	-45	-21	-51	-37	-56	-32	-62	-43	-89	
80	100	-30	-52	-24	-59	-44	-66	-38	-73	-51	-105	
100	120	-30	-52	-24	-59	-47	-69	-41	-76	-54	-108	
120	140	-37	-61	-28	-68	-56	-81	-48	-88	-63	-126	
140	160	-36	-61	-28	-68	-58	-83	-50	-90	-65	-128	
160	180	-36	-61	-28	-68	-61	-86	-53	-93	-68	-131	
180	200	-41	-70	-33	-79	-68	-97	-60	-106	-77	-149	
200	225	-41	-70	-33	-79	-71	-100	-63	-109	-80	-152	
225	250	-41	-70	-33	-79	-75	-104	-67	-113	-84	-156	
250	280	-47	-79	-36	-88	-85	-117	-74	-126	-94	-175	
280	315	-47	-79	-36	-88	-89	-121	-78	-130	-98	-179	
315	355	-51	-87	-41	-98	-97	-133	-87	-144	-108	-197	
355	400	-51	-87	-41	-98	-103	-139	-93	-150	-114	-203	
400	450	-55	-95	-45	-108	-113	-153	-103	-166	-126	-223	
450	500	-55	-95	-45	-108	-119	-159	-109	-172	-132	-229	

ISO TOLERANCES FOR SHAFTS – METRIC													
Diameters mm		Deviations in $\mu\text{m}$											
		a10		a11		a12		a13					
		high	low	high	low	high	low	high	low				
>	$\leq$												
—	3	-270	-310	-270	-330	-270	-370	-270	-410				
3	6	-270	-318	-270	-345	-270	-390	-270	-450				
6	10	-280	-338	-280	-370	-280	-430	-280	-500				
10	18	-290	-360	-290	-400	-290	-470	-290	-560				
18	30	-300	-384	-300	-430	-300	-510	-300	-630				
30	40	-310	-410	-310	-470	-310	-560	-310	-700				
40	50	-320	-420	-320	-480	-320	-570	-320	-710				
50	65	-340	-460	-340	-530	-340	-640	-340	-800				
65	80	-360	-480	-360	-550	-360	-660	-360	-820				
80	100	-380	-520	-380	-600	-380	-730	-380	-920				
100	120	-410	-550	-410	-630	-410	-760	-410	-950				
120	140	-460	-620	-460	-710	-460	-860	-460	-1090				
140	160	-520	-680	-520	-770	-520	-920	-520	-1150				
160	180	-580	-740	-580	-830	-580	-980	-580	-1210				
180	200	-660	-845	-660	-950	-660	-1120	-660	-1380				
200	225	-740	-925	-740	-1030	-740	-1200	-740	-1460				
225	250	-820	-1005	-820	-1110	-820	-1280	-820	-1540				
250	280	-920	-1130	-920	-1240	-920	-1440	-920	-1730				
280	315	-1050	-1260	-1050	-1370	-1050	-1570	-1050	-1860				
315	355	-1200	-1430	-1200	-1560	-1200	-1770	-1200	-2090				
355	400	-1350	-1580	-1350	-1710	-1350	-1920	-1350	-2240				

Diameters mm		Deviations in $\mu\text{m}$						Deviations in $\mu\text{m}$					
		c11		c12		c13		e11		e12		e13	
		high	low	high	low	high	low	high	low	high	low	high	low
>	$\leq$												
—	3	-60	-120	-60	-160	-60	-200	-14	-74	-14	-114	-14	-154
3	6	-70	-145	-70	-190	-70	-250	-20	-95	-20	-140	-20	-200
6	10	-80	-170	-80	-230	-80	-300	-25	-115	-25	-175	-25	-245
10	18	-95	-205	-95	-275	-95	-365	-32	-142	-32	-212	-32	-302
18	30	-110	-240	-110	-320	-110	-440	-40	-170	-40	-250	-40	-370
30	40	-120	-280	-120	-370	-120	-510	-50	-210	-50	-300	-50	-440
40	50	-130	-290	-130	-380	-130	-520	-50	-210	-50	-300	-50	-440
50	65	-140	-330	-140	-440	-140	-600	-60	-250	-60	-360	-60	-520
65	80	-150	-340	-150	-450	-150	-610	-60	-250	-60	-360	-60	-520
80	100	-170	-390	-170	-520	-170	-710	-72	-292	-72	-422	-72	-612
100	120	-180	-400	-180	-530	-180	-720	-72	-292	-72	-422	-72	-612
120	140	-200	-450	-200	-600	-200	-830	-85	-335	-85	-485	-85	-715
140	160	-210	-460	-210	-610	-210	-840	-85	-335	-85	-485	-85	-715
160	180	-230	-480	-230	-630	-230	-860	-85	-335	-85	-485	-85	-715
180	200	-240	-530	-240	-700	-240	-960	-100	-390	-100	-560	-100	-820
200	225	-260	-550	-260	-720	-260	-980	-100	-390	-100	-560	-100	-820
225	250	-280	-570	-280	-740	-280	-1000	-100	-390	-100	-560	-100	-820
250	280	-300	-620	-300	-820	-300	-1110	-110	-430	-110	-630	-110	-920
280	315	-330	-650	-330	-850	-330	-1140	-110	-430	-110	-630	-110	-920
315	355	-360	-720	-360	-930	-360	-1250	-125	-485	-125	-695	-125	-1015



BEARING TOLERANCES, INCH & METRIC - continued

ISO TOLERANCES FOR SHAFTS – METRIC

Diameters mm		Deviations in $\mu\text{m}$						Deviations in $\mu\text{m}$					
		f5		f6		f7		g5		g6		g7	
		high	low	high	low	high	low	high	low	high	low	high	low
>	$\leq$												
—	3	-6	-10	-6	-12	-6	-16	-2	-6	-2	-8	-2	-12
3	6	-10	-15	-10	-18	-10	-22	-4	-9	-4	-12	-4	-16
6	10	-13	-19	-13	-22	-13	-28	-5	-11	-5	-14	-5	-20
10	18	-16	-24	-16	-27	-16	-34	-6	-14	-6	-17	-6	-24
18	30	-20	-29	-20	-33	-20	-41	-7	-16	-7	-20	-7	-28
30	50	-25	-36	-25	-41	-25	-50	-9	-20	-9	-25	-9	-34
50	80	-30	-43	-30	-49	-30	-60	-10	-23	-10	-29	-10	-40
80	120	-36	-51	-36	-58	-36	-71	-12	-27	-12	-34	-12	-47
120	180	-43	-61	-43	-68	-43	-83	-14	-32	-14	-39	-14	-54
180	250	-50	-70	-50	-79	-50	-96	-15	-35	-15	-44	-15	-61
250	315	-56	-79	-56	-88	-56	-108	-17	-40	-17	-49	-17	-69
315	400	-62	-87	-62	-98	-62	-119	-18	-43	-18	-54	-18	-75

Diameters mm		Deviations in $\mu\text{m}$									
		h4		h5		h6		h7		h8	
		high	low	high	low	high	low	high	low	high	low
>	$\leq$										
—	3	0	-3	0	-4	0	-6	0	-10	0	-14
3	6	0	-4	0	-5	0	-8	0	-12	0	-18
6	10	0	-4	0	-6	0	-9	0	-15	0	-22
10	18	0	-5	0	-8	0	-11	0	-18	0	-27
18	30	0	-6	0	-9	0	-13	0	-21	0	-33
30	50	0	-7	0	-11	0	-16	0	-25	0	-39
50	80	0	-8	0	-13	0	-19	0	-30	0	-46
80	120	0	-10	0	-15	0	-22	0	-35	0	-54
120	180	0	-12	0	-18	0	-25	0	-40	0	-63
180	250	0	-14	0	-20	0	-29	0	-46	0	-72
250	315	0	-16	0	-23	0	-32	0	-52	0	-81
315	400	0	-18	0	-25	0	-36	0	-57	0	-89

Diameters mm		Deviations in $\mu\text{m}$									
		h9		h10		h11		h12		h13	
		high	low	high	low	high	low	high	low	high	low
>	$\leq$										
—	3	0	-25	0	-40	0	-60	0	-100	0	-140
3	6	0	-30	0	-48	0	-75	0	-120	0	-180
6	10	0	-36	0	-58	0	-90	0	-150	0	-220
10	18	0	-43	0	-70	0	-110	0	-180	0	-270
18	30	0	-52	0	-84	0	-130	0	-210	0	-330
30	50	0	-62	0	-100	0	-160	0	-250	0	-390
50	80	0	-74	0	-120	0	-190	0	-300	0	-460
80	120	0	-87	0	-140	0	-220	0	-350	0	-540
120	180	0	-100	0	-160	0	-250	0	-400	0	-630
180	250	0	-115	0	-185	0	-290	0	-460	0	-720
250	315	0	-130	0	-210	0	-320	0	-520	0	-810
315	400	0	-140	0	-230	0	-360	0	-570	0	-890



ISO TOLERANCES FOR SHAFTS – METRIC

Diameters mm		Deviations in $\mu\text{m}$						Deviations in $\mu\text{m}$					
		j5		j6		j7		k5		k6		k7	
>	$\leq$	high	low	high	low	high	low	high	low	high	low	high	low
—	3	+2	-2	+4	-2	+6	-4	+4	0	+6	0	+10	0
3	6	+3	-2	+6	-2	+8	-4	+6	+1	+9	+1	+13	+1
6	10	+4	-2	+7	-2	+10	-5	+7	+1	+10	+1	+16	+1
10	18	+5	-3	+8	-3	+12	-6	+9	+1	+12	+1	+19	+1
18	30	+5	-4	+9	-4	+13	-8	+11	+2	+15	+2	+23	+2
30	50	+6	-5	+11	-5	+15	-10	+13	+2	+18	+2	+27	+2
50	80	+6	-7	+12	-7	+18	-12	+15	+2	+21	+2	+32	+2
80	120	+6	-9	+13	-9	+20	-15	+18	+3	+25	+3	+38	+3
120	180	+7	-11	+14	-11	+22	-18	+21	+3	+28	+3	+43	+3
180	250	+7	-13	+16	-13	+25	-21	+24	+4	+33	+4	+50	+4
250	315	+7	-16	+16	-16	+26	-26	+27	+4	+36	+4	+56	+4
315	400	+7	-18	+18	-18	+29	-28	+29	+4	+40	+4	+61	+4

Diameters mm		Deviations in $\mu\text{m}$						Deviations in $\mu\text{m}$					
		m5		m6		m7		n5		n6		n7	
>	$\leq$	high	low	high	low	high	low	high	low	high	low	high	low
—	3	+6	+2	+8	+2	+12	+2	+8	+4	+10	+4	+14	+4
3	6	+9	+4	+12	+4	+16	+4	+13	+8	+16	+8	+20	+8
6	10	+12	+6	+15	+6	+21	+6	+16	+10	+19	+10	+25	+10
10	18	+15	+7	+18	+7	+25	+7	+20	+12	+23	+12	+30	+12
18	30	+17	+8	+21	+8	+29	+8	+24	+15	+28	+15	+36	+15
30	50	+20	+9	+25	+9	+34	+9	+28	+17	+33	+17	+42	+17
50	80	+24	+11	+30	+11	+41	+11	+33	+20	+39	+20	+50	+20
80	120	+28	+13	+35	+13	+48	+13	+38	+23	+45	+23	+58	+23
120	180	+33	+15	+40	+15	+55	+15	+45	+27	+52	+27	+67	+27
180	250	+37	+17	+46	+17	+63	+17	+51	+31	+60	+31	+77	+31
250	315	+43	+20	+52	+20	+72	+20	+57	+34	+66	+34	+86	+34
315	400	+46	+21	+57	+21	+78	+21	+62	+37	+73	+37	+94	+37

Diameters mm		Deviations in $\mu\text{m}$					
		p6		r6		r7	
>	$\leq$	high	low	high	low	high	low
3	6	-	-	-	-	-	-
6	10	-	-	-	-	-	-
10	18	-	-	-	-	-	-
18	30	-	-	-	-	-	-
30	50	-	-	-	-	-	-
50	65	-	-	-	-	-	-
65	80	-	-	-	-	-	-
80	100	+59	+37	-	-	-	-
100	120	+59	+37	-	-	-	-
120	140	+68	+43	+90	+65	-	-
140	160	+68	+43	+90	+65	-	-
160	180	+68	+43	+90	+65	-	-
180	200	+79	+50	+106	+77	-	-
200	225	+79	+50	+109	+80	+126	+80
225	250	+79	+50	+113	+84	+130	+84
250	280	+88	+56	+126	+94	+146	+94
280	315	+88	+56	+130	+98	+150	+98
315	355	+98	+62	+144	+108	+165	+108
355	400	+98	+62	+150	+114	+171	+114
400	450	+108	+68	+166	+126	+189	+126
450	500	+108	+68	+172	+132	+195	+132



BEARING TOLERANCES, INCH & METRIC - continued

ISO TOLERANCES FOR HOLES – INCH

Diameters inches		Deviations in inches						Deviations in inches					
		B10		B11		B12		C9		C10		C11	
>	≤	high	low	high	low	high	low	high	low	high	low	high	low
0.1181	0.2362	+0.0074	+0.0055	+0.0085	+0.0055	+0.0102	+0.0055	+0.0039	+0.0028	+0.0046	+0.0028	+0.0057	+0.0028
0.2362	0.3937	+0.0082	+0.0059	+0.0094	+0.0059	+0.0118	+0.0059	+0.0046	+0.0031	+0.0054	+0.0031	+0.0067	+0.0031
0.3937	0.7087	+0.0087	+0.0059	+0.0102	+0.0059	+0.0130	+0.0059	+0.0054	+0.0037	+0.0065	+0.0037	+0.0081	+0.0037
0.7087	1.1811	+0.0096	+0.0063	+0.0114	+0.0063	+0.0146	+0.0063	+0.0064	+0.0043	+0.0076	+0.0043	+0.0094	+0.0043
1.1811	1.5748	+0.0106	+0.0067	+0.0130	+0.0067	+0.0165	+0.0067	+0.0072	+0.0047	+0.0087	+0.0047	+0.0110	+0.0047
1.5748	1.9685	+0.0110	+0.0071	+0.0134	+0.0071	+0.0169	+0.0071	+0.0076	+0.0051	+0.0091	+0.0051	+0.0114	+0.0051
1.9685	2.5591	+0.0122	+0.0075	+0.0150	+0.0075	+0.0193	+0.0075	+0.0084	+0.0055	+0.0102	+0.0055	+0.0120	+0.0055
2.5591	3.1496	+0.0126	+0.0079	+0.0154	+0.0079	+0.0197	+0.0079	+0.0088	+0.0059	+0.0106	+0.0059	+0.0134	+0.0059
3.1496	3.9370	+0.0142	+0.0087	+0.0173	+0.0087	+0.0224	+0.0087	+0.0101	+0.0067	+0.0122	+0.0067	+0.0154	+0.0067
3.9370	4.7244	+0.0150	+0.0094	+0.0181	+0.0094	+0.0232	+0.0094	+0.0105	+0.0071	+0.0126	+0.0071	+0.0157	+0.0071
4.7244	5.5118	+0.0165	+0.0102	+0.0201	+0.0102	+0.0260	+0.0102	+0.0118	+0.0079	+0.0142	+0.0079	+0.0177	+0.0079
5.5118	6.2992	+0.0173	+0.0110	+0.0209	+0.0110	+0.0268	+0.0110	+0.0122	+0.0083	+0.0146	+0.0083	+0.0181	+0.0083
6.2992	7.0866	+0.0185	+0.0122	+0.0220	+0.0122	+0.0280	+0.0122	+0.0130	+0.0091	+0.0154	+0.0091	+0.0189	+0.0091
7.0866	7.8740	+0.0207	+0.0134	+0.0248	+0.0134	+0.0315	+0.0134	+0.0140	+0.0094	+0.0167	+0.0094	+0.0209	+0.0094
7.8740	8.8583	+0.0222	+0.0150	+0.0264	+0.0150	+0.0331	+0.0150	+0.0148	+0.0102	+0.0175	+0.0102	+0.0217	+0.0102
8.8583	9.8425	+0.0238	+0.0165	+0.0280	+0.0165	+0.0346	+0.0165	+0.0156	+0.0110	+0.0183	+0.0110	+0.0224	+0.0110
9.8425	11.0236	+0.0272	+0.0189	+0.0315	+0.0189	+0.0394	+0.0189	+0.0169	+0.0118	+0.0201	+0.0118	+0.0244	+0.0118
11.0236	12.4016	+0.0295	+0.0213	+0.0339	+0.0213	+0.0417	+0.0213	+0.0181	+0.0130	+0.0213	+0.0130	+0.0256	+0.0130
12.4016	13.9764	+0.0327	+0.0236	+0.0378	+0.0236	+0.0461	+0.0236	+0.0197	+0.0142	+0.0232	+0.0142	+0.0283	+0.0142
13.9764	15.7480	+0.0358	+0.0268	+0.0409	+0.0268	+0.0492	+0.0268	+0.0213	+0.0157	+0.0248	+0.0157	+0.0299	+0.0157
15.7480	17.7165	+0.0398	+0.0299	+0.0457	+0.0299	+0.0547	+0.0299	+0.0234	+0.0173	+0.0272	+0.0173	+0.0331	+0.0173
17.71654	19.6850	+0.0429	+0.0331	+0.0488	+0.0331	+0.0579	+0.0331	+0.0250	+0.0189	+0.0287	+0.0189	+0.0346	+0.0189

Diameters inches		Deviations in inches									
		E9		E10		E11		E12		E13	
>	≤	high	low	high	low	high	low	high	low	high	low
0.1181	0.2362	+0.0020	+0.0008	+0.0027	+0.0008	+0.0037	+0.0008	+0.0055	+0.0008	+0.0079	+0.0008
0.2362	0.3937	+0.0024	+0.0010	+0.0033	+0.0010	+0.0045	+0.0010	+0.0069	+0.0010	+0.0096	+0.0010
0.3937	0.7087	+0.0030	+0.0013	+0.0040	+0.0013	+0.0056	+0.0013	+0.0083	+0.0013	+0.0119	+0.0013
0.7087	1.1811	+0.0036	+0.0016	+0.0049	+0.0016	+0.0067	+0.0016	+0.0098	+0.0016	+0.0146	+0.0016
1.1811	1.9685	+0.0044	+0.0020	+0.0059	+0.0020	+0.0083	+0.0020	+0.0118	+0.0020	+0.0173	+0.0020
1.9685	3.1496	+0.0053	+0.0024	+0.0071	+0.0024	+0.0098	+0.0024	+0.0142	+0.0024	+0.0205	+0.0024
3.1496	4.7244	+0.0063	+0.0028	+0.0083	+0.0028	+0.0115	+0.0028	+0.0166	+0.0028	+0.0241	+0.0028
4.7244	7.0866	+0.0073	+0.0033	+0.0096	+0.0033	+0.0132	+0.0033	+0.0191	+0.0033	+0.0281	+0.0033
7.0866	9.8425	+0.0085	+0.0039	+0.0112	+0.0039	+0.0154	+0.0039	+0.0220	+0.0039	+0.0323	+0.0039
9.8425	12.4016	+0.0094	+0.0043	+0.0126	+0.0043	+0.0169	+0.0043	+0.0248	+0.0043	+0.0362	+0.0043
12.4016	15.7480	+0.0104	+0.0049	+0.0140	+0.0049	+0.0191	+0.0049	+0.0274	+0.0049	+0.0400	+0.0049
15.7480	19.6850	+0.0114	+0.0053	+0.0152	+0.0053	+0.0211	+0.0053	+0.0301	+0.0053	+0.0435	+0.0053

Diameters inches		Deviations in inches							
		F5		F6		F7		F8	
>	≤	high	low	high	low	high	low	high	low
0.1181	0.2362	+0.0006	+0.0004	+0.0007	+0.0004	+0.0009	+0.0004	+0.0011	+0.0004
0.2362	0.3937	+0.0007	+0.0005	+0.0009	+0.0005	+0.0011	+0.0005	+0.0014	+0.0005
0.3937	0.7087	+0.0009	+0.0006	+0.0011	+0.0006	+0.0013	+0.0006	+0.0017	+0.0006
0.7087	1.1811	+0.0011	+0.0008	+0.0013	+0.0008	+0.0016	+0.0008	+0.0021	+0.0008
1.1811	1.9685	+0.0014	+0.0010	+0.0016	+0.0010	+0.0020	+0.0010	+0.0025	+0.0010
1.9685	3.1496	+0.0017	+0.0012	+0.0019	+0.0012	+0.0024	+0.0012	+0.0030	+0.0012
3.1496	4.7244	+0.0020	+0.0014	+0.0023	+0.0014	+0.0028	+0.0014	+0.0035	+0.0014
4.7244	7.0866	+0.0024	+0.0017	+0.0027	+0.0017	+0.0033	+0.0017	+0.0042	+0.0017
7.0866	9.8425	+0.0028	+0.0020	+0.0031	+0.0020	+0.0038	+0.0020	+0.0048	+0.0020
9.8425	12.4016	+0.0031	+0.0022	+0.0035	+0.0022	+0.0043	+0.0022	+0.0054	+0.0022
12.4016	15.7480	+0.0034	+0.0024	+0.0039	+0.0024	+0.0047	+0.0024	+0.0059	+0.0024
15.7480	19.6850	+0.0037	+0.0027	+0.0043	+0.0027	+0.0052	+0.0027	+0.0065	+0.0027

ISO TOLERANCES FOR HOLES – INCH

Diameters inches		Deviations in inches					
		G5		G6		G7	
		high	low	high	low	high	low
>	≤						
0.1181	0.2362	+0.0004	+0.0002	+0.0005	+0.0002	+0.0006	+0.0002
0.2362	0.3937	+0.0004	+0.0002	+0.0006	+0.0002	+0.0008	+0.0002
0.3937	0.7087	+0.0006	+0.0002	+0.0007	+0.0002	+0.0009	+0.0002
0.7087	1.1811	+0.0006	+0.0003	+0.0008	+0.0003	+0.0011	+0.0003
1.1811	1.9685	+0.0008	+0.0004	+0.0010	+0.0004	+0.0013	+0.0004
1.9685	3.1496	+0.0009	+0.0004	+0.0011	+0.0004	+0.0016	+0.0004
3.1496	4.7244	+0.0011	+0.0005	+0.0013	+0.0005	+0.0019	+0.0005
4.7244	7.0866	+0.0013	+0.0006	+0.0015	+0.0006	+0.0021	+0.0006
7.0866	9.8425	+0.0014	+0.0006	+0.0017	+0.0006	+0.0024	+0.0006
9.8425	12.4016	+0.0016	+0.0007	+0.0019	+0.0007	+0.0027	+0.0007
12.4016	15.7480	+0.0017	+0.0007	+0.0021	+0.0007	+0.0030	+0.0007
15.7480	19.6850	+0.0019	+0.0008	+0.0024	+0.0008	+0.0033	+0.0008

Diameters inches		Deviations in inches									
		H4		H5		H6		H7		H8	
		high	low	high	low	high	low	high	low	high	low
>	≤										
0.1181	0.2362	+0.0002	0	+0.0002	0	+0.0003	0	+0.0005	0	+0.0007	0
0.2362	0.3937	+0.0002	0	+0.0002	0	+0.0004	0	+0.0006	0	+0.0009	0
0.3937	0.7087	+0.0002	0	+0.0003	0	+0.0004	0	+0.0007	0	+0.0011	0
0.7087	1.1811	+0.0002	0	+0.0004	0	+0.0005	0	+0.0008	0	+0.0013	0
1.1811	1.9685	+0.0003	0	+0.0004	0	+0.0006	0	+0.0010	0	+0.0015	0
1.9685	3.1496	+0.0003	0	+0.0005	0	+0.0007	0	+0.0012	0	+0.0018	0
3.1496	4.7244	+0.0004	0	+0.0006	0	+0.0009	0	+0.0014	0	+0.0021	0
4.7244	7.0866	+0.0005	0	+0.0007	0	+0.0010	0	+0.0016	0	+0.0025	0
7.0866	9.8425	+0.0006	0	+0.0008	0	+0.0011	0	+0.0018	0	+0.0028	0
9.8425	12.4016	+0.0006	0	+0.0009	0	+0.0013	0	+0.0020	0	+0.0032	0
12.4016	15.7480	+0.0007	0	+0.0010	0	+0.0014	0	+0.0022	0	+0.0035	0
15.7480	19.6850	+0.0008	0	+0.0011	0	+0.0016	0	+0.0025	0	+0.0038	0

Diameters inches		Deviations in inches							
		H9		H10		H11		H12	
		high	low	high	low	high	low	high	low
>	≤								
0.1181	0.2362	+0.0012	0	+0.0019	0	+0.0030	0	+0.0047	0
0.2362	0.3937	+0.0014	0	+0.0023	0	+0.0035	0	+0.0059	0
0.3937	0.7087	+0.0017	0	+0.0028	0	+0.0043	0	+0.0071	0
0.7087	1.1811	+0.0020	0	+0.0033	0	+0.0051	0	+0.0083	0
1.1811	1.9685	+0.0024	0	+0.0039	0	+0.0063	0	+0.0098	0
1.9685	3.1496	+0.0029	0	+0.0047	0	+0.0075	0	+0.0118	0
3.1496	4.7244	+0.0034	0	+0.0055	0	+0.0087	0	+0.0138	0
4.7244	7.0866	+0.0039	0	+0.0063	0	+0.0098	0	+0.0157	0
7.0866	9.8425	+0.0045	0	+0.0073	0	+0.0114	0	+0.0181	0
9.8425	12.4016	+0.0051	0	+0.0083	0	+0.0126	0	+0.0205	0
12.4016	15.7480	+0.0055	0	+0.0091	0	+0.0142	0	+0.0224	0
15.7480	19.6850	+0.0061	0	+0.0098	0	+0.0157	0	+0.0248	0



BEARING TOLERANCES, INCH & METRIC - continued

ISO TOLERANCES FOR HOLES – INCH													
Diameters inches		Deviations in inches						Deviations in inches					
		J6		J7		J8		K6		K7		K8	
>	≤	high	low	high	low	high	low	high	low	high	low	high	low
0.1181	0.2362	+0.00020	-0.00012	+0.00024	-0.00024	+0.00039	-0.00031	+0.00008	-0.00024	+0.00012	-0.00035	+0.00020	-0.00051
0.2362	0.3937	+0.00020	-0.00016	+0.00031	-0.00028	+0.00047	-0.00039	+0.00008	-0.00028	+0.00020	-0.00039	+0.00024	-0.00063
0.3937	0.7087	+0.00024	-0.00020	+0.00039	-0.00031	+0.00059	-0.00047	+0.00008	-0.00035	+0.00024	-0.00047	+0.00031	-0.00075
0.7087	1.1811	+0.00031	-0.00020	+0.00047	-0.00035	+0.00079	-0.00051	+0.00008	-0.00043	+0.00024	-0.00059	+0.00039	-0.00091
1.1811	1.9685	+0.00039	-0.00024	+0.00055	-0.00043	+0.00094	-0.00059	+0.00012	-0.00051	+0.00028	-0.00071	+0.00047	-0.00106
1.9685	3.1496	+0.00051	-0.00024	+0.00071	-0.00047	+0.00110	-0.00071	+0.00016	-0.00059	+0.00035	-0.00083	+0.00055	-0.00126
3.1496	4.7244	+0.00063	-0.00024	+0.00087	-0.00051	+0.00134	-0.00079	+0.00016	-0.00071	+0.00039	-0.00098	+0.00063	-0.00150
4.7244	7.0866	+0.00071	-0.00028	+0.00102	-0.00055	+0.00161	-0.00087	+0.00016	-0.00083	+0.00047	-0.00110	+0.00079	-0.00169
7.0866	9.8425	+0.00087	-0.00028	+0.00118	-0.00063	+0.00185	-0.00098	+0.00020	-0.00094	+0.00051	-0.00130	+0.00087	-0.00197
9.8425	12.4016	+0.00098	-0.00028	+0.00142	-0.00063	+0.00217	-0.00102	+0.00020	-0.00106	+0.00063	-0.00142	+0.00098	-0.00220
12.4016	15.7480	+0.00114	-0.00028	+0.00154	-0.00071	+0.00236	-0.00114	+0.00028	-0.00114	+0.00067	-0.00157	+0.00110	-0.00240
15.7480	19.6850	+0.00130	-0.00028	+0.00169	-0.00079	+0.00259	-0.00122	+0.00031	-0.00126	+0.00071	-0.00177	+0.00114	-0.00268

ISO TOLERANCES FOR HOLES – INCH													
Diameters inches		Deviations in inches						Deviations in inches					
		M5		M6		M7		N6		N7		N8	
>	≤	high	low	high	low	high	low	high	low	high	low	high	low
0.1181	0.2362	-0.00012	-0.00031	-0.00004	-0.00035	0	-0.00047	-0.00002	-0.00005	-0.00002	-0.00006	-0.00001	-0.00008
0.2362	0.3937	-0.00016	-0.00039	-0.00012	-0.00047	0	-0.00059	-0.00003	-0.00006	-0.00002	-0.00007	-0.00001	-0.00010
0.3937	0.7087	-0.00016	-0.00047	-0.00016	-0.00059	0	-0.00071	-0.00004	-0.00008	-0.00002	-0.00009	-0.00001	-0.00012
0.7087	1.1811	-0.00020	-0.00055	-0.00016	-0.00067	0	-0.00083	-0.00004	-0.00009	-0.00003	-0.00011	-0.00001	-0.00014
1.1811	1.9685	-0.00020	-0.00063	-0.00016	-0.00079	0	-0.00098	-0.00005	-0.00011	-0.00003	-0.00013	-0.00001	-0.00017
1.9685	3.1496	-0.00024	-0.00075	-0.00020	-0.00094	0	-0.00118	-0.00006	-0.00013	-0.00004	-0.00015	-0.00002	-0.00020
3.1496	4.7244	-0.00031	-0.00091	-0.00024	-0.00110	0	-0.00138	-0.00006	-0.00015	-0.00004	-0.00018	-0.00002	-0.00023
4.7244	7.0866	-0.00035	-0.00106	-0.00031	-0.00130	0	-0.00157	-0.00008	-0.00018	-0.00005	-0.00020	-0.00002	-0.00026
7.0866	9.8425	-0.00043	-0.00122	-0.00031	-0.00146	0	-0.00181	-0.00009	-0.00020	-0.00006	-0.00024	-0.00002	-0.00030
9.8425	12.4016	-0.00051	-0.00142	-0.00035	-0.00161	0	-0.00205	-0.00000	-0.00022	-0.00006	-0.00026	-0.00002	-0.00034
12.4016	15.7480	-0.00055	-0.00154	-0.00039	-0.00181	0	-0.00224	-0.00010	-0.00024	-0.00006	-0.00029	-0.00002	-0.00037
15.7480	19.6850	-0.00063	-0.00169	-0.00039	-0.00197	0	-0.00248	-0.00011	-0.00026	-0.00007	-0.00031	-0.00002	-0.00041

ISO TOLERANCES FOR HOLES – INCH													
Diameters inches		Deviations in inches						Deviations in inches					
		P6		P7		R6		R7		R8			
>	≤	high	low	high	low	high	low	high	low	high	low	high	low
0.1181	0.2362	-0.00004	-0.00007	-0.00003	-0.00008	-0.00005	-0.00008	-0.00004	-0.00009	-0.00006	-0.00013	-0.00006	-0.00013
0.2362	0.3937	-0.00005	-0.00008	-0.00004	-0.00009	-0.00006	-0.00010	-0.00005	-0.00011	-0.00007	-0.00016	-0.00007	-0.00016
0.3937	0.7087	-0.00006	-0.00010	-0.00004	-0.00011	-0.00008	-0.00012	-0.00006	-0.00013	-0.00009	-0.00020	-0.00009	-0.00020
0.7087	1.1811	-0.00007	-0.00012	-0.00006	-0.00014	-0.00009	-0.00015	-0.00008	-0.00016	-0.00011	-0.00024	-0.00011	-0.00024
1.1811	1.9685	-0.00008	-0.00015	-0.00007	-0.00017	-0.00011	-0.00018	-0.00010	-0.00020	-0.00013	-0.00029	-0.00013	-0.00029
1.9685	2.5591	-0.00010	-0.00018	-0.00008	-0.00020	-0.00014	-0.00021	-0.00012	-0.00024	-0.00016	-0.00034	-0.00016	-0.00034
2.5591	3.1496	-0.00010	-0.00018	-0.00008	-0.00020	-0.00015	-0.00022	-0.00013	-0.00024	-0.00017	-0.00035	-0.00017	-0.00035
3.1496	3.9370	-0.00012	-0.00020	-0.00009	-0.00023	-0.00017	-0.00026	-0.00015	-0.00029	-0.00020	-0.00041	-0.00020	-0.00041
3.9370	4.7244	-0.00012	-0.00020	-0.00009	-0.00023	-0.00019	-0.00027	-0.00016	-0.00030	-0.00021	-0.00043	-0.00021	-0.00043
4.7244	5.5118	-0.00014	-0.00024	-0.00011	-0.00027	-0.00022	-0.00032	-0.00019	-0.00035	-0.00025	-0.00050	-0.00025	-0.00050
5.5118	6.2992	-0.00014	-0.00024	-0.00011	-0.00027	-0.00023	-0.00033	-0.00020	-0.00035	-0.00026	-0.00050	-0.00026	-0.00050
6.2992	7.0866	-0.00014	-0.00024	-0.00011	-0.00027	0.00024	-0.00034	-0.00021	-0.00037	-0.00027	-0.00052	-0.00027	-0.00052
7.0866	7.8740	-0.00016	-0.00028	-0.00013	-0.00031	-0.00027	-0.00038	-0.00024	-0.00042	-0.00030	-0.00059	-0.00030	-0.00059
7.8740	8.8583	-0.00016	-0.00028	-0.00013	-0.00031	0.00028	-0.00039	-0.00025	-0.00043	-0.00031	-0.00060	-0.00031	-0.00060
8.8583	9.8425	-0.00016	-0.00028	-0.00013	-0.00031	-0.00030	-0.00041	-0.00026	-0.00044	-0.00033	-0.00061	-0.00033	-0.00061
9.8425	11.0236	-0.00019	-0.00031	-0.00014	-0.00035	-0.00033	-0.00046	-0.00029	-0.00050	-0.00037	-0.00069	-0.00037	-0.00069
11.0236	12.4016	-0.00019	-0.00031	-0.00014	-0.00035	-0.00035	-0.00048	-0.00031	-0.00051	-0.00039	-0.00070	-0.00039	-0.00070
12.4016	13.9764	-0.00020	-0.00034	-0.00016	-0.00039	-0.00038	-0.00052	-0.00034	-0.00057	-0.00043	-0.00078	-0.00043	-0.00078
13.9764	15.7480	-0.00020	-0.00034	-0.00016	-0.00039	-0.00041	-0.00055	-0.00037	-0.00059	-0.00045	-0.00080	-0.00045	-0.00080
15.7480	17.7165	-0.00022	-0.00037	-0.00018	-0.00043	-0.00044	-0.00060	-0.00041	-0.00065	-0.00050	-0.00088	-0.00050	-0.00088
17.7165	19.6850	-0.00022	-0.00037	-0.00018	-0.00043	-0.00047	-0.00063	-0.00043	-0.00068	-0.00052	-0.00090	-0.00052	-0.00090

**ISO TOLERANCES FOR SHAFTS – INCH**

Diameters inches		Deviations in inches							
		a10		a11		a12		a13	
		high	low	high	low	high	low	high	low
>	≤								
—	0.1181	-0.0106	-0.0122	-0.0106	-0.0130	-0.0106	-0.0146	-0.0106	-0.0161
0.1181	0.2362	-0.0106	-0.0125	-0.0106	-0.0136	-0.0106	-0.0154	-0.0106	-0.0177
0.2362	0.3937	-0.0110	-0.0133	-0.0110	-0.0146	-0.0110	-0.0169	-0.0110	-0.0197
0.3937	0.7087	-0.0114	-0.0142	-0.0114	-0.0157	-0.0114	-0.0185	-0.0114	-0.0220
0.7087	1.1811	-0.0118	-0.0151	-0.0118	-0.0169	-0.0118	-0.0201	-0.0118	-0.0248
1.1811	1.5748	-0.0122	-0.0161	-0.0122	-0.0185	-0.0122	-0.0220	-0.0122	-0.0276
1.5748	1.9685	-0.0126	-0.0165	-0.0126	-0.0189	-0.0126	-0.0224	-0.0126	-0.0280
1.9685	2.5591	-0.0134	-0.0181	-0.0134	-0.0209	-0.0134	-0.0252	-0.0134	-0.0315
2.5591	3.1496	-0.0142	-0.0189	-0.0142	-0.0217	-0.0142	-0.0260	-0.0142	-0.0323
3.1496	3.9370	-0.0150	-0.0205	-0.0150	-0.0236	-0.0150	-0.0287	-0.0150	-0.0362
3.9370	4.7244	-0.0161	-0.0217	-0.0161	-0.0248	-0.0161	-0.0299	-0.0161	-0.0374
4.7244	5.5118	-0.0181	-0.0244	-0.0181	-0.0280	-0.0181	-0.0339	-0.0181	-0.0429
5.5118	6.2992	-0.0205	-0.0268	-0.0205	-0.0303	-0.0205	-0.0362	-0.0205	-0.0453
6.2992	7.0866	-0.0228	-0.0291	-0.0228	-0.0327	-0.0228	-0.0386	-0.0228	-0.0476
7.0866	7.8740	-0.0260	-0.0333	-0.0260	-0.0374	-0.0260	-0.0441	-0.0260	-0.0543
7.8740	8.8583	-0.0291	-0.0364	-0.0291	-0.0406	-0.0291	-0.0472	-0.0291	-0.0575
8.8583	9.8425	-0.0323	-0.0396	-0.0323	-0.0437	-0.0323	-0.0504	-0.0323	-0.0606
9.8425	11.0236	-0.0362	-0.0445	-0.0362	-0.0488	-0.0362	-0.0567	-0.0362	-0.0681
11.0236	12.4016	-0.0413	-0.0496	-0.0413	-0.0539	-0.0413	-0.0618	-0.0413	-0.0732
12.4016	13.9764	-0.0472	-0.0563	-0.0472	-0.0614	-0.0472	-0.0697	-0.0472	-0.0823
13.9764	15.7480	-0.0531	-0.0622	-0.0531	-0.0673	-0.0531	-0.0756	-0.0531	-0.0882

Diameters inches		Deviations in inches						Deviations in inches					
		c11		c12		c13		e11		e12		e13	
		high	low	high	low	high	low	high	low	high	low	high	low
>	≤												
—	0.1181	-0.0024	-0.0047	-0.0024	-0.0063	-0.0024	-0.0079	-0.0006	-0.0029	-0.0006	-0.0045	-0.0006	-0.0061
0.1181	0.2362	-0.0028	-0.0057	-0.0028	-0.0075	-0.0028	-0.0098	-0.0008	-0.0037	-0.0008	-0.0055	-0.0008	-0.0079
0.2362	0.3937	-0.0031	-0.0067	-0.0031	-0.0091	-0.0031	-0.0118	-0.0010	-0.0045	-0.0010	-0.0069	-0.0010	-0.0096
0.3937	0.7087	-0.0037	-0.0081	-0.0037	-0.0108	-0.0037	-0.0144	-0.0013	-0.0056	-0.0013	-0.0083	-0.0013	-0.0119
0.7087	1.1811	-0.0043	-0.0094	-0.0043	-0.0126	-0.0043	-0.0173	-0.0016	-0.0067	-0.0016	-0.0098	-0.0016	-0.0146
1.1811	1.5748	-0.0047	-0.0110	-0.0047	-0.0146	-0.0047	-0.0201	-0.0020	-0.0083	-0.0020	-0.0118	-0.0020	-0.0173
1.5748	1.9685	-0.0051	-0.0114	-0.0051	-0.0150	-0.0051	-0.0205	-0.0020	-0.0083	-0.0020	-0.0118	-0.0020	-0.0173
1.9685	2.5591	-0.0055	-0.0130	-0.0055	-0.0173	-0.0055	-0.0236	-0.0024	-0.0098	-0.0024	-0.0142	-0.0024	-0.0205
2.5591	3.1496	-0.0059	-0.0134	-0.0059	-0.0177	-0.0059	-0.0240	-0.0024	-0.0098	-0.0024	-0.0142	-0.0024	-0.0205
3.1496	3.9370	-0.0067	-0.0154	-0.0067	-0.0205	-0.0067	-0.0280	-0.0028	-0.0115	-0.0028	-0.0166	-0.0028	-0.0241
3.9370	4.7244	-0.0071	-0.0157	-0.0071	-0.0209	-0.0071	-0.0283	-0.0028	-0.0115	-0.0028	-0.0166	-0.0028	-0.0241
4.7244	5.5118	-0.0079	-0.0177	-0.0079	-0.0236	-0.0079	-0.0327	-0.0033	-0.0132	-0.0033	-0.0191	-0.0033	-0.0281
5.5118	6.2992	-0.0083	-0.0181	-0.0083	-0.0240	-0.0083	-0.0331	-0.0033	-0.0132	-0.0033	-0.0191	-0.0033	-0.0281
6.2992	7.0866	-0.0091	-0.0189	-0.0091	-0.0248	-0.0091	-0.0339	-0.0033	-0.0132	-0.0033	-0.0191	-0.0033	-0.0281
7.0866	7.8740	-0.0094	-0.0209	-0.0094	-0.0276	-0.0094	-0.0378	-0.0039	-0.0154	-0.0039	-0.0220	-0.0039	-0.0323
7.8740	8.8583	-0.0102	-0.0217	-0.0102	-0.0283	-0.0102	-0.0386	-0.0039	-0.0154	-0.0039	-0.0220	-0.0039	-0.0323
8.8583	9.8425	-0.0110	-0.0224	-0.0110	-0.0291	-0.0110	-0.0394	-0.0039	-0.0154	-0.0039	-0.0220	-0.0039	-0.0323
9.8425	11.0236	-0.0118	-0.0244	-0.0118	-0.0323	-0.0118	-0.0437	-0.0043	-0.0169	-0.0043	-0.0248	-0.0043	-0.0362
11.0236	12.4016	-0.0130	-0.0256	-0.0130	-0.0335	-0.0130	-0.0449	-0.0043	-0.0169	-0.0043	-0.0248	-0.0043	-0.0362
12.4016	13.9764	-0.0142	-0.0283	-0.0142	-0.0366	-0.0142	-0.0492	-0.0049	-0.0191	-0.0049	-0.0274	-0.0049	-0.0400
13.9764	15.7480	-0.0157	-0.0299	-0.0157	-0.0382	-0.0157	-0.0508	-0.0049	-0.0191	-0.0049	-0.0274	-0.0049	-0.0400



BEARING TOLERANCES, INCH & METRIC - continued

ISO TOLERANCES FOR SHAFTS – INCH

Diameters inches		Deviations in inches						Deviations in inches					
		f5		f6		f7		g5		g6		g7	
		high	low	high	low	high	low	high	low	high	low	high	low
>	≤												
—	0.1181	-0.0002	-0.0004	-0.0002	-0.0005	-0.0002	-0.0006	-0.0001	-0.0002	-0.0001	-0.0003	-0.0001	-0.0005
0.1181	0.2362	-0.0004	-0.0006	-0.0004	-0.0007	-0.0004	-0.0009	-0.0002	-0.0004	-0.0002	-0.0005	-0.0002	-0.0006
0.2362	0.3937	-0.0005	-0.0007	-0.0005	-0.0009	-0.0005	-0.0011	-0.0002	-0.0004	-0.0002	-0.0006	-0.0002	-0.0008
0.3937	0.7087	-0.0006	-0.0009	-0.0006	-0.0011	-0.0006	-0.0013	-0.0002	-0.0006	-0.0002	-0.0007	-0.0002	-0.0009
0.7087	1.1811	-0.0008	-0.0011	-0.0008	-0.0013	-0.0008	-0.0016	-0.0003	-0.0006	-0.0003	-0.0008	-0.0003	-0.0011
1.1811	1.9685	-0.0010	-0.0014	-0.0010	-0.0016	-0.0010	-0.0020	-0.0004	-0.0008	-0.0004	-0.0010	-0.0004	-0.0013
1.9685	3.1496	-0.0012	-0.0017	-0.0012	-0.0019	-0.0012	-0.0024	-0.0004	-0.0009	-0.0004	-0.0011	-0.0004	-0.0016
3.1496	4.7244	-0.0014	-0.0020	-0.0014	-0.0023	-0.0014	-0.0028	-0.0005	-0.0011	-0.0005	-0.0013	-0.0005	-0.0019
4.7244	7.0866	-0.0017	-0.0024	-0.0017	-0.0027	-0.0017	-0.0033	-0.0006	-0.0013	-0.0006	-0.0015	-0.0006	-0.0021
7.0866	9.8425	-0.0020	-0.0028	-0.0020	-0.0031	-0.0020	-0.0038	-0.0006	-0.0014	-0.0006	-0.0017	-0.0006	-0.0024
9.8425	12.4016	-0.0022	-0.0031	-0.0022	-0.0035	-0.0022	-0.0043	-0.0007	-0.0016	-0.0007	-0.0019	-0.0007	-0.0027
12.4016	15.7480	-0.0024	-0.0034	-0.0024	-0.0039	-0.0024	-0.0047	-0.0007	-0.0017	-0.0007	-0.0021	-0.0007	-0.0030

Diameters inches		Deviations in inches									
		h4		h5		h6		h7		h8	
		high	low	high	low	high	low	high	low	high	low
>	≤										
—	0.1181	0	-0.00012	0	-0.00016	0	-0.00024	0	-0.0004	0	-0.0006
0.1181	0.2362	0	-0.00016	0	-0.00020	0	-0.00031	0	-0.0005	0	-0.0007
0.2362	0.3937	0	-0.0002	0	-0.00024	0	-0.0004	0	-0.0006	0	-0.0009
0.3937	0.7087	0	-0.0002	0	-0.00031	0	-0.0004	0	-0.0007	0	-0.0011
0.7087	1.1811	0	-0.0002	0	-0.0004	0	-0.0005	0	-0.0008	0	-0.0013
1.1811	1.9685	0	-0.0003	0	-0.0004	0	-0.0006	0	-0.0010	0	-0.0015
1.9685	3.1496	0	-0.0003	0	-0.0005	0	-0.0007	0	-0.0012	0	-0.0018
3.1496	4.7244	0	-0.0004	0	-0.0006	0	-0.0009	0	-0.0014	0	-0.0021
4.7244	7.0866	0	-0.0005	0	-0.0007	0	-0.0010	0	-0.0016	0	-0.0025
7.0866	9.8425	0	-0.0006	0	-0.0008	0	-0.0011	0	-0.0018	0	-0.0028
9.8425	12.4016	0	-0.0006	0	-0.0009	0	-0.0013	0	-0.0020	0	-0.0032
12.4016	15.7480	0	-0.0007	0	-0.0010	0	-0.0014	0	-0.0022	0	-0.0035

Diameters inches		Deviations in inches									
		h9		h10		h11		h12		h13	
		high	low	high	low	high	low	high	low	high	low
>	≤										
—	0.1181	0	-0.0010	0	-0.0016	0	-0.0024	0	-0.0039	0	-0.0055
0.1181	0.2362	0	-0.0012	0	-0.0019	0	-0.0030	0	-0.0047	0	-0.0071
0.2362	0.3937	0	-0.0014	0	-0.0023	0	-0.0035	0	-0.0059	0	-0.0087
0.3937	0.7087	0	-0.0017	0	-0.0028	0	-0.0043	0	-0.0071	0	-0.0106
0.7087	1.1811	0	-0.0020	0	-0.0033	0	-0.0051	0	-0.0083	0	-0.0130
1.1811	1.9685	0	-0.0024	0	-0.0039	0	-0.0063	0	-0.0098	0	-0.0154
1.9685	3.1496	0	-0.0029	0	-0.0047	0	-0.0075	0	-0.0118	0	-0.0181
3.1496	4.7244	0	-0.0034	0	-0.0055	0	-0.0087	0	-0.0138	0	-0.0213
4.7244	7.0866	0	-0.0039	0	-0.0063	0	-0.0098	0	-0.0157	0	-0.0248
7.0866	9.8425	0	-0.0045	0	-0.0073	0	-0.0114	0	-0.0181	0	-0.0283
9.8425	12.4016	0	-0.0051	0	-0.0083	0	-0.0126	0	-0.0205	0	-0.0319
12.4016	15.7480	0	-0.0055	0	-0.0091	0	-0.0142	0	-0.0224	0	-0.0350

ISO TOLERANCES FOR SHAFTS – INCH

Diameters inches		Deviations in inches						Deviations in inches					
		j5		j6		j7		k5		k6		k7	
		high	low	high	low	high	low	high	low	high	low	high	low
>	≤												
—	0.1181	+0.00008	-0.00008	+0.00016	-0.00008	+0.00024	-0.00016	+0.00016	0	+0.00024	0	+0.00039	0
0.1181	0.2362	+0.00012	-0.00008	+0.00024	-0.00008	+0.00031	-0.00016	+0.00024	+0.00004	+0.00035	+0.00004	+0.00051	+0.00004
0.2362	0.3937	+0.00016	-0.00008	+0.00028	-0.00008	+0.00039	-0.00020	+0.00028	+0.00004	+0.00039	+0.00004	+0.00063	+0.00004
0.3937	0.7087	+0.00020	-0.00012	+0.00031	-0.00012	+0.00047	-0.00024	+0.00035	+0.00004	+0.00047	+0.00004	+0.00075	+0.00004
0.7087	1.1811	+0.00020	-0.00016	+0.00035	-0.00016	+0.00051	-0.00031	+0.00043	+0.00008	+0.00059	+0.00008	+0.00091	+0.00008
1.1811	1.9685	+0.00024	-0.00020	+0.00043	-0.00020	+0.00059	-0.00039	+0.00051	+0.00008	+0.00071	+0.00008	+0.00106	+0.00008
1.9685	3.1496	+0.00024	-0.00028	+0.00047	-0.00028	+0.00071	-0.00047	+0.00059	+0.00008	+0.00083	+0.00008	+0.00126	+0.00008
3.1496	4.7244	+0.00024	-0.00035	+0.00051	-0.00035	+0.00079	-0.00059	+0.00071	+0.00012	+0.00098	+0.00012	+0.00150	+0.00012
4.7244	7.0866	+0.00028	-0.00043	+0.00055	-0.00043	+0.00087	-0.00071	+0.00083	+0.00012	+0.00110	+0.00012	+0.00169	+0.00012
7.0866	9.8425	+0.00028	-0.00051	+0.00063	-0.00051	+0.00098	-0.00083	+0.00094	+0.00016	+0.00130	+0.00016	+0.00197	+0.00016
9.8425	12.4016	+0.00028	-0.00063	+0.00063	-0.00063	+0.00102	-0.00102	+0.00106	+0.00016	+0.00142	+0.00016	+0.00220	+0.00016
12.4016	15.7480	+0.00028	-0.00071	+0.00071	-0.00071	+0.00114	-0.00110	+0.00114	+0.00016	+0.00157	+0.00016	+0.00240	+0.00016

Diameters inches		Deviations in inches						Deviations in inches					
		m5		m6		m7		n5		n6		n7	
		high	low	high	low	high	low	high	low	high	low	high	low
>	≤												
—	0.1181	+0.00024	+0.00008	+0.00031	+0.00008	+0.00047	+0.00008	+0.0003	+0.0002	+0.0004	+0.0002	+0.0006	+0.0002
0.1181	0.2362	+0.00035	+0.00016	+0.00047	+0.00016	+0.00063	+0.00016	+0.0005	+0.0003	+0.0006	+0.0003	+0.0008	+0.0003
0.2362	0.3937	+0.00047	+0.00024	+0.00059	+0.00024	+0.00083	+0.00024	+0.0006	+0.0004	+0.0007	+0.0004	+0.0010	+0.0004
0.3937	0.7087	+0.00059	+0.00028	+0.00071	+0.00028	+0.00098	+0.00028	+0.0008	+0.0005	+0.0009	+0.0005	+0.0012	+0.0005
0.7087	1.1811	+0.00067	+0.00031	+0.00083	+0.00031	+0.00114	+0.00031	+0.0009	+0.0006	+0.0011	+0.0006	+0.0014	+0.0006
1.1811	1.9685	+0.00079	+0.00035	+0.00098	+0.00035	+0.00134	+0.00035	+0.0011	+0.0007	+0.0013	+0.0007	+0.0017	+0.0007
1.9685	3.1496	+0.00094	+0.00043	+0.00118	+0.00043	+0.00161	+0.00043	+0.0013	+0.0008	+0.0015	+0.0008	+0.0020	+0.0008
3.1496	4.7244	+0.00110	+0.00051	+0.00138	+0.00051	+0.00189	+0.00051	+0.0015	+0.0009	+0.0018	+0.0009	+0.0023	+0.0009
4.7244	7.0866	+0.00130	+0.00059	+0.00157	+0.00059	+0.00217	+0.00059	+0.0018	+0.0011	+0.0020	+0.0011	+0.0026	+0.0011
7.0866	9.8425	+0.00146	+0.00067	+0.00181	+0.00067	+0.00248	+0.00067	+0.0020	+0.0012	+0.0024	+0.0012	+0.0030	+0.0012
9.8425	12.4016	+0.00169	+0.00079	+0.00205	+0.00079	+0.00283	+0.00079	+0.0022	+0.0013	+0.0026	+0.0013	+0.0034	+0.0013
12.4016	15.7480	+0.00181	+0.00083	+0.00224	+0.00083	+0.00307	+0.00083	+0.0024	+0.0015	+0.0029	+0.0015	+0.0037	+0.0015

Diameters inches		Deviations in inches					
		p6		r6		r7	
		high	low	high	low	high	low
>	≤						
0.1181	0.2362	-	-	-	-	-	-
0.2362	0.3937	-	-	-	-	-	-
0.3937	0.7087	-	-	-	-	-	-
0.7087	1.1811	-	-	-	-	-	-
1.1811	1.9685	-	-	-	-	-	-
1.9685	2.5591	-	-	-	-	-	-
2.5591	3.1496	-	-	-	-	-	-
3.1496	3.9370	+0.0023	+0.0015	-	-	-	-
3.9370	4.7244	+0.0023	+0.0015	-	-	-	-
4.7244	5.5118	+0.0027	+0.0017	+0.0035	+0.0026	-	-
5.5118	6.2992	+0.0027	+0.0017	+0.0035	+0.0026	-	-
6.2992	7.0866	+0.0027	+0.0017	+0.0035	+0.0026	-	-
7.0866	7.8740	+0.0031	+0.0020	+0.0042	+0.0030	-	-
7.8740	8.8583	+0.0031	+0.0020	+0.0043	+0.0031	+0.0050	+0.0031
8.8583	9.8425	+0.0031	+0.0020	+0.0044	+0.0033	+0.0051	+0.0033
9.8425	11.0236	+0.0035	+0.0022	+0.0050	+0.0037	+0.0057	+0.0037
11.0236	12.4016	+0.0035	+0.0022	+0.0051	+0.0039	+0.0059	+0.0039
12.4016	13.9764	+0.0039	+0.0024	+0.0057	+0.0043	+0.0065	+0.0043
13.9764	15.7480	+0.0039	+0.0024	+0.0059	+0.0045	+0.0067	+0.0045
15.7480	17.7165	+0.0043	+0.0027	+0.0065	+0.0050	+0.0074	+0.0050
17.7165	19.6850	+0.0043	+0.0027	+0.0068	+0.0052	+0.0077	+0.0052



## MOUNTING DESIGNS

Correct bearing mounting and fitting practices are key components of proper bearing setting. Setting is the amount of clearance or interference within a mounted bearing. Bearing internal clearance is affected by the tightness of the fit to the inner and outer races. Proper bearing setting is crucial to bearing life and performance. Although clearance is required for most mounted bearings, application dependant factors include load, speed, bearing position, installation method, materials of construction, runout accuracy, thermal considerations, hoop stress, and shaft and housing design. This section provides tables and discussion to aid in selection of the proper bearing mounting and fitting procedures to optimize performance in general applications. For special applications, please consult your Timken representative for review.

### RADIAL BALL BEARINGS

In the manufacture of rolling element bearings, it is standard practice to assemble rings and rolling elements with a specified internal clearance. This characteristic is necessary to absorb the effect of press fitting the bearing rings at mounting.

Internal clearance is sometimes utilized to compensate for thermal expansion of bearings, shafts and housings or to provide a contact angle in the bearing after mounting.

Internal clearance can be measured either by gaging radially or axially.

Radial measurement is accepted as the more significant characteristic for most bearing types because it is more directly related to shaft and housing fits. It also is the method prescribed by the American Bearing Manufacturers Association (ABMA). However, tapered roller bearings and duplex sets of angular contact ball bearings are usually set axially.

The radial internal clearance (RIC) of a radial contact ball bearing can be defined as the average outer ring raceway diameter minus the average inner ring raceway diameter minus twice the ball diameter.

(RIC) can be measured mechanically by moving the outer ring, horizontally as pictured in Figure A-12. The total movement of the outer ring when the balls are properly seated in the raceways determines the (RIC). Several readings should be taken using different circumferential orientations of the rings in order to get a comprehensive average reading.

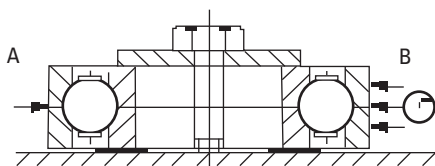

Fig. A-12

The Timken Company radial clearance designations correlate with ABMA symbols as follows:

Bearing Number Prefix	ABMA Symbol	Description
H	2	Snug; slight internal clearance; sometimes used to achieve a minimum of radial or axial play in an assembly, Example: H204K
R	0	Medium; internal clearance generally satisfactory with suggested shaft and housing fits. Example: RMM204K.
P	3	Loose; considerable internal clearance required for applications involving press fits on both inner and outer rings, extra interference fits or temperature differentials. Example: P204K.
J	4	Extra Loose; large amount of internal clearance for applications involving large interference fits or temperature differentials. Example: J204K.
JJ	5	Extra-Extra Loose; extra large amount of internal clearance for applications with large temperature differential and interference fits on both rings.

### ENDPLAY

Endplay is an alternate method of measuring internal clearance and is rarely used except for certain special applications. Endplay is determined by mounting the bearing, as shown in Figure A-13, with one of its rings clamped to prevent axial movement. A reversing measuring load is applied to the unclamped ring so that the resultant movement of that ring is parallel to the bearing axis. Endplay is the total movement of the unclamped ring when the load is applied first in one direction and then in the other.

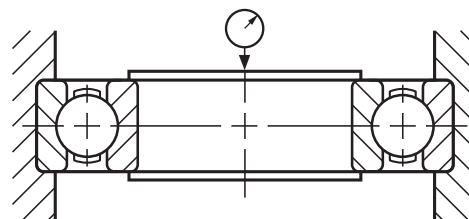

Fig. A-13

When the inner and outer ring raceway curvatures are accurately known, the free endplay can readily be calculated from the values of no load radial clearance by the following formula:

$$E = \sqrt{4dR_D(K_0 + K_i - 1) - R_D^2} \text{ or } \sqrt{4dR_D(K_0 + K_i - 1)}$$

(Where  $R_D^2$  is generally a very small value and can be omitted for most calculations without introducing undue inaccuracy.)

$E$  = Free endplay where

$K_0$  = outer race contour radius expressed as a decimal fraction of the ball diameter.

$K_i$  = inner race contour radius expressed as a decimal fraction of the ball diameter

$R_D$  = radial clearance (no load)

$d$  = ball diameter

RADIAL BALL BEARINGS

LIMITS FOR RADIAL INTERNAL CLEARANCE OF SINGLE-ROW, RADIAL CONTACT BALL BEARINGS UNDER NO LOAD (APPLIES TO BEARINGS OF ABEC 1, ABEC 3, ABEC 5, ABEC 7, AND ABEC 9 TOLERANCES)											
All tolerances in number of micrometers (µm) and ten-thousandths inches (.0001")											
Timken® Prefix (ABMA designation)		H (C2)		R (C0)		P (C3)		J (C4)		JJ (C5)	
Basic Bore Diameter MM		Acceptance Limits		Acceptance Limits		Acceptance Limits		Acceptance Limits		Acceptance Limit	
over	incl.	low	high	low	high	low	high	low	high	low	high
		mm	mm	mm	mm	mm	mm	mm	mm	mm	mm
		in.	in.	in.	in.	in.	in.	in.	in.	in.	in.
2.5	10	0	7	2	13	8	23	14	29	20	37
		0	3	1	5	3	9	6	11	8	15
10	18	0	9	3	18	11	25	18	33	25	45
		0	3.5	1	7	4	10	7	13	10	18
18	24	0	10	5	20	13	28	20	36	28	48
		0	4	2	8	5	11	8	14	11	19
24	30	1	11	5	20	13	28	23	41	30	53
		0.5	4.5	2	8	5	11	9	16	12	21
30	40	1	11	6	20	15	33	28	46	40	64
		0.5	4.5	2	8	6	13	11	18	16	25
40	50	1	11	6	23	18	36	30	51	45	73
		0.5	4.5	2.5	9	7	14	12	20	18	29
50	65	1	15	8	28	23	43	38	61	55	90
		0.5	6	3.5	11	9	17	15	24	22	35
65	80	1	15	10	30	25	51	46	71	65	105
		0.5	6	4	12	10	20	18	28	26	41
80	100	1	18	12	36	30	58	53	84	75	120
		0.5	7	4.5	14	12	23	21	33	30	47
100	120	2	20	15	41	36	66	61	97	90	140
		1	8	6	16	14	26	24	38	35	55
120	140	2	23	18	48	41	81	71	114	105	160
		1	9	7	19	16	32	28	45	41	63
140	160	2	23	18	53	46	91	81	130	120	180
		1	9	7	21	18	36	32	51	47	71
160	180	2	25	20	61	53	102	91	147	135	200
		1	10	8	24	21	40	36	58	53	79
180	200	2	30	25	71	63	117	107	163	150	230
		1	12	10	28	25	46	42	64	59	91
200	240	3	36	30	81	74	137	127	193	183	267
		1	14	12	32	29	54	50	76	72	105
240	280	3	41	33	97	86	157	147	224	213	310
		1	16	13	38	34	62	58	88	84	122
280	320	5	48	41	114	104	180	170	257	246	353
		2	19	16	45	41	71	67	101	97	139
320	370	5	53	46	127	117	208	198	295	284	409
		2	21	18	50	46	82	78	116	112	161
370	430	8	64	56	147	137	241	231	340	330	475
		3	25	22	58	54	95	91	134	130	187
430	500	10	74	66	170	160	279	269	396	386	551
		4	29	26	67	63	110	106	156	152	217
500	570	10	81	74	193	183	318	307	450	439	630
		4	32	29	76	72	125	121	177	173	248
570	640	13	91	85	216	206	356	345	505	495	706
		5	36	33	85	81	140	136	199	195	278
640	710	20	114	107	239	229	394	384	564	554	780
		8	45	42	94	90	155	151	222	218	307
710	800	20	140	130	269	259	445	434	630	620	879
		8	55	51	106	102	175	171	248	244	346
800	1060	28	211	201	353	345	587	577	833	823	1148
		11	83	79	139	136	231	227	328	324	452

Standard fits for Timken radial ball bearings. P(C3) for bearing O.D. greater than 52 mm.

**MOUNTING DESIGNS** - *continued***CONTACT ANGLE**

The contact angle ( $\alpha$ ) is related to internal clearance as follows:

$$\alpha = \sin^{-1} \left( \frac{E}{2 (K_o + K_i - 1) d} \right)$$

The contact angle ( $\alpha$ ) may also be accurately determined in a production bearing from its pitch diameter (P.D.) and by measuring the number of revolutions ( $N_c$ ) of the ball and cage assembly relative to rotation ( $N_i$ ) of the inner ring under a light thrust load.

$$(N_c) = 0.5N_i \left( 1 - \frac{d}{d_m} \cos \alpha \right)$$

$$\cos \alpha = \frac{d_m}{d} \left( 1 - \frac{N_c}{0.5N_i} \right)$$

The accuracy of this method of measurement depends greatly upon the care taken in set up. Balanced weight for thrust loading, vertical turning, slow turning, many turns, minimum lubricant of low viscosity and pre-rotation are all essential for instance. The races should not be radially restrained during the contact angle measurement.

MOUNTING DESIGNS - continued

**RADIAL SPHERICAL ROLLER BEARINGS**

Timken bearing RIC allows a tight fit, with sufficient internal clearance after installation for normal operating conditions.

Spherical roller bearings with tapered bore (K) require a slightly greater interference fit on the shaft than would a cylindrical bore bearing. The effect of this greater interference fit is a reduction of RIC. For tapered bore bearings, it is critical to select the RIC that allows for this reduction.

For example, bearing number 22328K C3 (140 mm bore with C3 clearance) is to be mounted on a tapered shaft. By feeler gaging, RIC is found to be 0.178 mm (0.007 in.). The chart indicates that the proper fit will be obtained when RIC is reduced by 0.064 to 0.089 mm (0.0025 in. to 0.0035 in.). Clearance after mounting is computed:  $0.178 - 0.076 = 0.102$  mm (0.007 in. - 0.003 in. = 0.004 in.). The locknut should be tightened until RIC reaches 0.102 mm (0.004 in.).

Several factors influence RIC reduction. Inner rings pressed into solid steel shafts expand approximately 80 percent of the interference fit. Outer rings pressed into steel or cast iron housings reduce RIC by about 60 percent of the interference fit. For RIC reduction on hollow shafts or non-steel materials, consult your local Timken representative.

Timken bearings are supplied with NORMAL RIC, unless otherwise specified. The desired RIC code must be added to the bearing number, FOLLOWING ALL OTHER SUFFIXES.

Min./max. values for each RIC are shown in the two adjacent columns directly beneath the selected RIC. Each single column represents a boundary between adjacent RICs. For example, the minimum values shown for C5 are also the maximum values for C4; minimum values for C4 are also the maximum values for C3; etc.

**SPHERICAL ROLLER BEARING ENDPLAY**

In certain applications such as vane pumps, rubber mill rotor shafts or where it is necessary to take up axial expansion within the bearing, knowledge of the bearing endplay relationship to mounted radial internal clearance may be required. The following table showing the ratio of approximate endplay to radial internal clearance in spherical roller bearings can be used to calculate approximate endplay in the bearing.

Example: 22320CJW33C3 bearing has a radial internal clearance after installation of .002. The total endplay would be approximately .0086 in. ( $\pm .0043$  from center)

Series	E.P. RIC
39	8.7
30	7.0
22	5.5
31	5.0
40	4.8
32	4.4
23	4.3
41	4.2
33	3.9

MOUNTING DESIGNS - continued

RADIAL INTERNAL CLEARANCE LIMITS – RADIAL SPHERICAL ROLLER BEARINGS

All data on this page, except Bore I.D., are in millimeters/inches

Bore (nominal)		Cylindrical Bore						Tapered Bore						Suggested Reduction of RIC Due to Installation		Suggested RIC after Installation <sup>(1)</sup>		
		Normal C0			C4			Normal C0			C4							
		Min.		Max.	Min.		Max.	Min.		Max.	Min.		Max.					
		C2	C3	C5	C2	C3	C5	C2	C3	C5	C2	C3	C5					
mm	mm	mm	mm	mm	mm	mm	mm	mm	mm	mm	mm	mm	mm	mm	mm	mm	mm	mm
over	incl.	inch	inch	inch	inch	inch	inch	inch	inch	inch	inch	inch	inch	inch	inch	inch	inch	inch
24	30	0.015	0.025	0.040	0.055	0.075	0.095	0.020	0.030	0.040	0.055	0.075	0.095	0.015	0.020	0.015		
		0.0006	0.0010	0.0016	0.0022	0.0030	0.0037	0.0008	0.0012	0.0016	0.0022	0.0030	0.0037	0.0006	0.0008	0.0006		
30	40	0.015	0.030	0.045	0.060	0.080	1.000	0.025	0.035	0.050	0.065	0.085	0.105	0.020	0.025	0.015		
		0.0006	0.0012	0.0018	0.0024	0.0031	0.0039	0.0010	0.0014	0.0020	0.0026	0.0033	0.0041	0.0008	0.0010	0.0006		
40	50	0.020	0.035	0.055	0.075	0.100	0.125	0.030	0.045	0.060	0.080	0.100	0.130	0.025	0.030	0.020		
		0.0008	0.0014	0.0022	0.0030	0.0039	0.0049	0.0012	0.0018	0.0024	0.0031	0.0039	0.0051	0.0010	0.0012	0.0008		
50	65	0.020	0.040	0.065	0.090	0.120	0.150	0.040	0.055	0.075	0.095	0.120	0.160	0.030	0.038	0.025		
		0.0008	0.0016	0.0026	0.0035	0.0047	0.0059	0.0016	0.0022	0.0030	0.0037	0.0047	0.0063	0.0012	0.0015	0.0010		
65	80	0.030	0.050	0.080	0.110	0.145	0.180	0.050	0.070	0.095	0.120	0.150	0.200	0.038	0.051	0.025		
		0.0012	0.0020	0.0031	0.0043	0.0057	0.0071	0.0020	0.0028	0.0037	0.0047	0.0059	0.0079	0.0015	0.0020	0.0010		
80	100	0.035	0.060	0.100	0.135	0.180	0.225	0.055	0.080	0.110	0.140	0.180	0.230	0.046	0.064	0.036		
		0.0014	0.0024	0.0039	0.0053	0.0071	0.0089	0.0022	0.0030	0.0043	0.0055	0.0071	0.0091	0.0018	0.0025	0.0014		
100	120	0.040	0.075	0.120	0.160	0.210	0.260	0.065	0.100	0.135	0.170	0.220	0.280	0.051	0.071	0.051		
		0.0016	0.0030	0.0047	0.0063	0.0083	0.0102	0.0026	0.0039	0.0053	0.0067	0.0087	0.0110	0.0020	0.0028	0.0020		
120	140	0.050	0.095	0.145	0.190	0.240	0.300	0.080	0.120	0.160	0.200	0.260	0.330	0.064	0.089	0.056		
		0.0020	0.0037	0.0057	0.0075	0.0094	0.0118	0.0031	0.0047	0.0063	0.0079	0.0102	0.0130	0.0025	0.0035	0.0022		
140	160	0.060	0.110	0.170	0.220	0.280	0.350	0.090	0.130	0.180	0.230	0.300	0.380	0.076	0.102	0.056		
		0.0024	0.0043	0.0067	0.0087	0.0110	0.0138	0.0035	0.0051	0.0071	0.0091	0.0118	0.0150	0.0030	0.0040	0.0022		
160	180	0.065	0.120	0.180	0.240	0.310	0.390	0.100	0.140	0.200	0.260	0.340	0.430	0.076	0.114	0.061		
		0.0026	0.0047	0.0071	0.0094	0.0122	0.0154	0.0039	0.0055	0.0079	0.0102	0.0134	0.0169	0.0030	0.0045	0.0024		
180	200	0.070	0.130	0.200	0.260	0.340	0.430	0.110	0.160	0.220	0.290	0.370	0.470	0.089	0.127	0.071		
		0.0028	0.0051	0.0079	0.0102	0.0134	0.0169	0.0043	0.0063	0.0087	0.0114	0.0146	0.0185	0.0035	0.0050	0.0028		
200	225	0.080	0.140	0.220	0.290	0.380	0.470	0.120	0.180	0.250	0.320	0.410	0.520	0.102	0.140	0.076		
		0.0031	0.0055	0.0087	0.0114	0.0150	0.0185	0.0047	0.0071	0.0098	0.0126	0.0161	0.0205	0.0040	0.0055	0.0030		
225	250	0.090	0.150	0.240	0.320	0.420	0.520	0.140	0.200	0.270	0.350	0.450	0.570	0.114	0.152	0.089		
		0.0035	0.0059	0.0094	0.0126	0.0165	0.0205	0.0055	0.0079	0.0106	0.0138	0.0177	0.0224	0.0045	0.0060	0.0035		
250	280	0.100	0.170	0.260	0.350	0.460	0.570	0.150	0.220	0.300	0.390	0.490	0.620	0.114	0.165	0.102		
		0.0039	0.0067	0.0102	0.0138	0.0181	0.0224	0.0059	0.0087	0.0118	0.0154	0.0193	0.0244	0.0045	0.0065	0.0040		
280	315	0.110	0.190	0.280	0.370	0.500	0.630	0.170	0.240	0.330	0.430	0.540	0.680	0.127	0.178	0.102		
		0.0043	0.0075	0.0110	0.0146	0.0197	0.0248	0.0067	0.0094	0.0130	0.0169	0.0213	0.0268	0.0050	0.0070	0.0040		
315	355	0.120	0.200	0.310	0.410	0.550	0.690	0.190	0.270	0.360	0.470	0.590	0.740	0.140	0.190	0.114		
		0.0047	0.0079	0.0122	0.0161	0.0217	0.0272	0.0075	0.0106	0.0142	0.0185	0.0232	0.0291	0.0055	0.0075	0.0045		
355	400	0.130	0.220	0.340	0.450	0.600	0.750	0.210	0.300	0.400	0.520	0.650	0.820	0.152	0.203	0.127		
		0.0051	0.0087	0.0134	0.0177	0.0236	0.0295	0.0083	0.0118	0.0157	0.0205	0.0256	0.0323	0.0060	0.0080	0.0050		
400	450	0.140	0.240	0.370	0.500	0.660	0.820	0.230	0.330	0.440	0.570	0.720	0.910	0.165	0.216	0.152		
		0.0055	0.0094	0.0146	0.0197	0.0260	0.0323	0.0091	0.0130	0.0173	0.0224	0.0283	0.0358	0.0065	0.0085	0.0060		
450	500	0.140	0.260	0.410	0.550	0.720	0.900	0.260	0.370	0.490	0.630	0.790	1.000	0.178	0.229	0.165		
		0.0055	0.0102	0.0161	0.0217	0.0283	0.0354	0.0102	0.0146	0.0193	0.0248	0.0311	0.0394	0.0070	0.0090	0.0065		
500	560	0.150	0.280	0.440	0.600	0.780	1.000	0.290	0.410	0.540	0.680	0.870	1.100	0.203	0.254	0.178		
		0.0059	0.0110	0.0173	0.0236	0.0307	0.0394	0.0114	0.0161	0.0213	0.0268	0.0343	0.0433	0.0080	0.0100	0.0070		
560	630	0.170	0.310	0.480	0.650	0.850	1.100	0.320	0.460	0.600	0.760	0.980	1.230	0.229	0.279	0.203		
		0.0067	0.0122	0.0189	0.0256	0.0335	0.0433	0.0126	0.0181	0.0236	0.0299	0.0386	0.0484	0.0090	0.0110	0.0080		
630	710	0.190	0.350	0.530	0.700	0.920	1.190	0.350	0.510	0.670	0.850	1.090	1.360	0.254	0.305	0.203		
		0.0075	0.0138	0.0209	0.0276	0.0362	0.0469	0.0138	0.0201	0.0264	0.0335	0.0429	0.0535	0.0100	0.0120	0.0080		
710	800	0.210	0.390	0.580	0.770	1.010	1.300	0.390	0.570	0.750	0.960	1.220	1.500	0.279	0.356	0.229		
		0.0083	0.0154	0.0228	0.0303	0.0398	0.0512	0.0154	0.0224	0.0295	0.0378	0.0480	0.0591	0.0110	0.0140	0.0090		
800	900	0.230	0.430	0.650	0.860	1.120	1.440	0.440	0.640	0.840	1.070	1.370	1.690	0.305	0.381	0.252		
		0.0091	0.0169	0.0256	0.0339	0.0441	0.0567	0.0173	0.0252	0.0331	0.0421	0.0539	0.0665	0.0120	0.0150	0.0100		
900	1000	0.260	0.480	0.710	0.930	1.220	1.57	0.490	0.710	0.930	1.190	1.520	1.860	0.356	0.432	0.279		
		0.0102	0.0189	0.0280	0.0366	0.0480	0.0618	0.0193	0.0280	0.0366	0.0469	0.0598	0.0732	0.0140	0.0170	0.0110		

<sup>(1)</sup>For bearings with normal initial clearance.

■ : For bearings with normal initial clearance.

Min./Max. values for each RIC are shown in the two adjacent columns directly beneath the selected RIC. Each single column represents a boundary between adjacent RICs. For example, the minimum values shown for C5 are also the maximum values for C4; minimum values for C4 are also the maximum values for C3, etc.

\* Special clearances can be provided (C6, C7, etc.)

MOUNTING DESIGNS - continued

CYLINDRICAL ROLLER BEARINGS

Cylindrical roller bearings are available with Radial Internal Clearance designations per either of the following tables: "Timken 'R' Clearance" or "ISO/ABMA 'C' Clearance." Non-standard values are also available by special request. Standard radial internal clearance values are listed in the following tables based on bore size. The clearance required for a given application depends on

the desired operating precision, rotational speed of the bearing, and the fitting practice used. Most applications use a normal or C0 clearance. Typically, larger clearance reduces the operating zone of the bearing, increases the maximum roller load and reduces the bearing's expected life.

CYLINDRICAL ROLLER BEARING RADIAL INTERNAL CLEARANCE LIMITS											
Bore, mm		R.I.C. (0.0001 inch and µm)									
over	incl.	C2		C0		C3		C4		C5	
		Min.	Max.	Min.	Max.	Min.	Max.	Min.	Max.	Min.	Max.
		mm	mm	mm	mm	mm	mm	mm	mm	mm	mm
		in.	in.	in.	in.	in.	in.	in.	in.	in.	in.
-	10	0	25	20	45	35	60	50	75	-	-
		0	10	8	18	14	24	20	30	-	-
10	24	0	25	20	45	35	60	50	75	65	90
		0	10	8	18	14	24	20	30	26	35
24	30	0	25	20	45	35	60	50	75	70	95
		0	10	8	18	14	24	20	30	28	37
30	40	5	30	25	50	45	70	60	85	80	105
		2	12	10	20	18	28	24	33	31	41
40	50	5	35	30	60	50	80	70	100	95	125
		2	14	12	24	20	31	28	39	37	49
50	65	10	40	40	70	60	90	80	110	110	140
		4	16	16	28	24	35	31	43	43	55
65	80	10	45	40	75	65	100	90	125	130	165
		4	18	16	30	26	39	35	49	51	65
80	100	15	50	50	85	75	110	105	140	155	190
		6	20	20	33	30	43	41	55	61	75
100	120	15	55	50	90	85	125	125	165	180	220
		6	22	20	35	33	49	49	65	71	87
120	140	15	60	60	105	100	145	145	190	200	245
		6	24	24	41	39	57	57	75	79	96
140	160	20	70	70	120	115	165	165	215	225	275
		8	28	28	47	45	65	65	85	89	108
160	180	25	75	75	125	120	170	170	220	250	300
		10	30	30	49	47	67	67	87	98	118
180	200	35	90	90	145	140	195	195	250	275	330
		14	35	35	57	55	77	77	98	108	130
200	225	45	105	105	165	160	220	220	280	305	365
		18	41	41	65	63	87	87	110	120	144
225	250	45	110	110	175	170	235	235	300	330	395
		18	43	43	69	67	93	93	118	130	156
250	280	55	125	125	195	190	260	260	330	370	440
		22	49	49	77	75	102	102	130	146	173
280	315	55	130	130	205	200	275	275	350	410	485
		22	51	51	81	79	108	108	138	161	191
315	355	65	145	145	225	225	305	305	385	455	535
		26	57	57	89	89	120	120	152	179	211
355	400	100	190	190	280	280	370	370	460	510	600
		39	75	75	110	110	146	146	181	201	236
400	450	110	210	210	310	310	410	410	510	565	665
		43	83	83	122	122	161	161	201	222	262
450	500	110	220	220	330	330	440	440	550	625	735
		43	87	87	130	130	173	173	217	246	289
500	560	120	240	240	360	360	480	480	600	690	810
		47.2	94.5	94.5	141.7	141.7	189.0	189.0	236.2	271.7	318.9
560	630	140	260	260	380	380	500	500	620	780	900
		55.1	102.4	102.4	149.6	149.6	196.9	196.9	244.1	307.1	354.3
630	710	145	285	285	425	425	565	565	705	865	1005
		57.1	112.2	112.2	167.3	167.3	222.4	222.4	277.6	340.6	395.7
710	800	150	310	310	470	470	630	630	790	975	1135
		59.1	122.0	122.0	185.0	185.0	248.0	248.0	311.0	383.9	446.9
800	900	180	350	350	520	520	690	690	860	1095	1265
		70.9	137.8	137.8	204.7	204.7	271.7	271.7	338.6	431.1	498.0
900	1000	200	390	390	580	580	770	770	960	1215	1405
		78.7	153.5	153.5	228.3	228.3	303.1	303.1	378.0	478.3	553.1

These values indicate the expected range of mounted RIC following suggested push up values. Timken suggests that customers consult with our engineers to evaluate unique applications or requirements for special operating conditions.



MOUNTING DESIGNS - *continued*

**RADIAL CYLINDRICAL ROLLER BEARINGS**

Min./Max. values for each RIC are shown in the two adjacent columns directly beneath the selected RIC. Each single column represents a boundary between adjacent RICs. For example, the minimum values shown for R5 are also the maximum values for R4; minimum values for R4 are also the maximum values for R3, etc. The desired RIC code (R1, R2, etc.) must be added to the bearing number, FOLLOWING ALL OTHER SUFFIXES.

**RADIAL INTERNAL CLEARANCE LIMITS**

All data on this chart are in millimeters/inches.

Bore (nominal)		R2		R4		R5	
		Min.	Max.	Min.	Max.		
Over	Incl.	R1		R3		R5	
		Min.	Max.	Min.	Max.	Min.	Max.
mm in.	mm in.	mm in.	mm in.	mm in.	mm in.	mm in.	mm in.
<b>80</b>	<b>100</b>	<b>0.013</b>	<b>0.041</b>	<b>0.081</b>	<b>0.130</b>	<b>0.196</b>	<b>0.272</b>
3.1496	3.9370	0.0005	0.0016	0.0032	0.0051	0.0077	0.0107
<b>100</b>	<b>120</b>	<b>0.013</b>	<b>0.046</b>	<b>0.091</b>	<b>0.152</b>	<b>0.226</b>	<b>0.310</b>
3.9370	4.7244	0.0005	0.0018	0.0036	0.0060	0.0089	0.0122
<b>120</b>	<b>140</b>	<b>0.023</b>	<b>0.056</b>	<b>0.104</b>	<b>0.170</b>	<b>0.256</b>	<b>0.353</b>
4.7244	5.5118	0.0009	0.0022	0.0041	0.0067	0.0101	0.0139
<b>140</b>	<b>160</b>	<b>0.025</b>	<b>0.066</b>	<b>0.124</b>	<b>0.196</b>	<b>0.284</b>	<b>0.384</b>
5.5118	6.2992	0.0010	0.0026	0.0049	0.0077	0.0112	0.0151
<b>160</b>	<b>180</b>	<b>0.028</b>	<b>0.069</b>	<b>0.132</b>	<b>0.208</b>	<b>0.300</b>	<b>0.401</b>
6.2992	7.0866	0.0011	0.0027	0.0052	0.0082	0.0118	0.0158
<b>180</b>	<b>200</b>	<b>0.036</b>	<b>0.081</b>	<b>0.152</b>	<b>0.234</b>	<b>0.330</b>	<b>0.437</b>
7.0866	7.8740	0.0014	0.0032	0.0060	0.0092	0.0130	0.0172
<b>200</b>	<b>220</b>	<b>0.041</b>	<b>0.086</b>	<b>0.157</b>	<b>0.239</b>	<b>0.335</b>	<b>0.4421</b>
7.8740	8.6614	0.0016	0.0034	0.0062	0.0094	0.0132	0.0174
<b>220</b>	<b>260</b>	<b>0.056</b>	<b>0.102</b>	<b>0.173</b>	<b>0.254</b>	<b>0.351</b>	<b>0.455</b>
8.6614	10.2362	0.0022	0.0040	0.0068	0.0100	0.0138	0.0180
<b>260</b>	<b>300</b>	<b>0.061</b>	<b>0.107</b>	<b>0.178</b>	<b>0.259</b>	<b>0.356</b>	<b>0.462</b>
10.2362	11.8110	0.0024	0.0042	0.0070	0.0102	0.0140	0.0182

Bore (nominal)		R2		R4		R5	
		Min.	Max.	Min.	Max.		
Over	Incl.	R1		R3		R5	
		Min.	Max.	Min.	Max.	Min.	Max.
mm in.	mm in.	mm in.	mm in.	mm in.	mm in.	mm in.	mm in.
<b>300</b>	<b>350</b>	<b>0.081</b>	<b>0.127</b>	<b>0.198</b>	<b>0.279</b>	<b>0.376</b>	<b>0.483</b>
11.8110	13.7795	0.0032	0.0050	0.0078	0.0110	0.0148	0.0190
<b>350</b>	<b>400</b>	<b>0.107</b>	<b>0.165</b>	<b>0.236</b>	<b>0.318</b>	<b>0.414</b>	<b>0.521</b>
13.7795	15.7480	0.0042	0.0065	0.0093	0.0125	0.0163	0.0205
<b>400</b>	<b>450</b>	<b>0.14</b>	<b>0.203</b>	<b>0.279</b>	<b>0.361</b>	<b>0.457</b>	<b>0.564</b>
15.7480	17.7165	0.0055	0.0080	0.0110	0.0142	0.0180	0.0222
<b>450</b>	<b>500</b>	<b>0.152</b>	<b>0.216</b>	<b>0.292</b>	<b>0.381</b>	<b>0.508</b>	<b>0.645</b>
17.7165	19.6850	0.0060	0.0085	0.0115	0.0150	0.0200	0.0254
<b>500</b>	<b>560</b>	<b>0.165</b>	<b>0.229</b>	<b>0.305</b>	<b>0.406</b>	<b>0.533</b>	<b>0.671</b>
19.6850	22.0472	0.0065	0.0090	0.0120	0.0160	0.0210	0.0264
<b>560</b>	<b>630</b>	<b>0.178</b>	<b>0.254</b>	<b>0.356</b>	<b>0.483</b>	<b>0.610</b>	<b>0.747</b>
22.0472	24.8031	0.0070	0.0100	0.0140	0.0190	0.0240	0.0294
<b>630</b>	<b>710</b>	<b>0.190</b>	<b>0.279</b>	<b>0.381</b>	<b>0.508</b>	<b>0.635</b>	<b>0.772</b>
24.8031	27.9528	0.0075	0.0110	0.0150	0.0200	0.0250	0.0304
<b>710</b>	<b>800</b>	<b>0.216</b>	<b>0.330</b>	<b>0.457</b>	<b>0.584</b>	<b>0.711</b>	<b>0.848</b>
27.9528	31.4961	0.0085	0.0130	0.0180	0.2300	0.0280	0.0334



MOUNTING DESIGNS - continued

NEEDLE ROLLER BEARINGS

INSPECTION OF DRAWN CUP NEEDLE ROLLER BEARINGS

Although the bearing cup is accurately drawn from strip steel because of its fairly thin section, it may go out of round during heat treatment. When the bearing is pressed into a true round housing or ring gage, of correct size and wall thickness, it becomes round and is sized properly. **For this reason, it is incorrect to inspect an unmounted drawn cup bearing by measuring the outside diameter.** The correct method for inspecting the bearing size is to:

1. Press the bearing into a ring gage of proper size.
2. Plug the bearing bore with the appropriate “go” and “no go” gages or measure it with a tapered arbor (lathe mandrel).

Table 15 lists the “go” gage size for metric bearings which is the minimum needle roller complement bore diameter. The “no go” gage size is larger than the maximum needle roller complement bore diameter by 0.002 mm.

TABLE 15

HK METRIC SERIES BEARINGS			
Nominal bore diameter mm	Ring gage *	Dimensions – mm	
		Needle roller complement bore diameter (F <sub>ws min</sub> )	
		Min.	Max.
3	6.484	3.006	3.024
4	7.984	4.010	4.028
5	8.984	5.010	5.028
6	9.984	6.010	6.028
7	10.980	7.013	7.031
8	11.980	8.013	8.031
9	12.980	9.013	9.031
10	13.980	10.013	10.031
12	15.980	12.016	12.034
12	17.980	12.016	12.034
13	18.976	13.016	13.034
14	19.976	14.016	14.034
15	20.976	15.016	15.034
16	21.976	16.016	16.034
17	22.976	17.016	17.034
18	23.976	18.016	18.034
20	25.976	20.020	20.041
22	27.976	22.020	22.041
25	31.972	25.020	25.041
28	34.972	28.020	28.041
30	36.972	30.020	30.041
35	41.972	35.025	35.050
40	46.972	40.025	40.050
45	51.967	45.025	45.050
50	57.967	50.025	50.050
60	67.967	60.030	60.060

\* The ring gage sizes are in accordance with ISO N6 lower limit.

Inspection procedures

Table 15-B provides the correct ring and plug gage diameters for inspecting inch drawn cup needle roller bearings. When the letter H appears in the columns headed “Bearing Bore Designation” and “Nominal Shaft Diameter”, the gage sizes listed are for the larger cross section bearings which include H in their bearing designation prefix.

Example

Find the ring gage and plug gage dimensions for a BH-68 bearing. The nominal bore diameter (F<sub>w</sub>) for this bearing, as shown in the table of dimensions is .3750 inch. Since the letter H appears in the bearing designation, the following information will be found opposite H6 .3750 in Table 15-B.

	INCH
ring gage	.6255
diameter under needle rollers, min.	.3765
diameter under needle rollers, max.	.3774

The “go” plug gage is the same size as the minimum needle roller complement bore diameter and the “no go” plug gage size is .00001 inch larger than the maximum bore diameter. Therefore the correct ring and plug gage dimensions are:

	INCH
ring gage	.6255
plug gage, “go”	.3765
plug gage, “no go”	.3775

These same gage dimensions also apply to JH-68.

MOUNTING DESIGNS - continued

TABLE 15-B

INCH SERIES EXTRA-PRECISION BEARINGS					
Bearing bore designation	Nominal shaft diameter	Nominal bore diameter	Dimensions – inch		
			Ring gage	Needle roller complement bore diameter	
				Min.	Max.
2	1/8	.1250	.2505	.1258	.1267
2 1/2	5/32	.1562	.2817	.1571	.1580
3	3/16	.1875	.3437	.1883	.1892
4	1/4	.2500	.4380	.2515	.2524
5	5/16	.3125	.5005	.3140	.3149
H 5	H 5/16	.3125	.5630	.3140	.3149
6	3/8	.3750	.5630	.3765	.3774
H 6	H 3/8	.3750	.6255	.3765	.3774
7	7/16	.4375	.6255	.4390	.4399
H 7	H 7/16	.4375	.6880	.4390	.4399
8	1/2	.5000	.6880	.5015	.5024
H 8	H 1/2	.5000	.7505	.5015	.5024
9	9/16	.5625	.7505	.5640	.5649
H 9	H 9/16	.5625	.8130	.5640	.5649
10	5/8	.6250	.8130	.6265	.6274
H 10	H 5/8	.6250	.8755	.6265	.6274
11	11/16	.6875	.8755	.6890	.6899
H 11	H 11/16	.6875	.9380	.6890	.6899
12	3/4	.7500	.9380	.7515	.7524
H 12	H 3/4	.7500	1.0620	.7515	.7524
13	13/16	.8125	1.0620	.8130	.8139
H 13	H 13/16	.8125	1.1245	.8130	.8139
14	7/8	.8750	1.1245	.8755	.8764
H 14	H 7/8	.8750	1.1870	.8755	.8764
15	15/16	.9375	1.1870	.9380	.9389
16	1	1.0000	1.2495	1.0005	1.0014
H 16	H 1	1.0000	1.3120	1.0005	1.0014
17	1 1/16	1.0625	1.3120	1.0630	1.0639
18	1 1/8	1.1250	1.3745	1.1255	1.1264
H 18	H 1 1/8	1.1250	1.4995	1.1255	1.1264
19	1 3/16	1.1875	1.4995	1.1880	1.1889
20	1 1/4	1.2500	1.4995	1.2505	1.2514
H 20	H 1 1/4	1.2500	1.6245	1.2505	1.2514
21	1 5/16	1.3125	1.6245	1.3130	1.3140
22	1 3/8	1.3750	1.6245	1.3755	1.3765
H 22	H 1 3/8	1.3750	1.7495	1.3755	1.3765
24	1 1/2	1.5000	1.7495	1.5005	1.5014
26	1 5/8	1.6250	1.9995	1.6255	1.6266
28	1 3/4	1.7500	2.1245	1.7505	1.7517
30	1 7/8	1.8750	2.2495	1.8755	1.8767
32	2	2.0000	2.3745	2.0006	2.0018
H 32	H 2 1/16	2.0625	2.5307	2.0635	2.0649
34	2 1/8	2.1250	2.4995	2.1256	2.1270
36	2 1/4	2.2500	2.6245	2.2506	2.2520
42	2 3/8	2.6250	2.9995	2.6260	2.6274
44	2 3/4	2.7500	3.1245	2.7510	2.7524
56	3 1/2	3.5000	3.9995	3.5010	3.5024
88	5 1/2	5.5000	5.9990	5.5010	5.5029

Bearing bore should be checked with “go” and “no go” plug gages. The “go” gage size is the minimum needle roller complement bore diameter. The “no go” gage size is larger than the maximum needle roller complement bore diameter by 0.0001 inch.

Inspection dimensions for the extra-precision bearings are given in the table below. Note that these bearings must be inspected while mounted in the specified ring gage. Bearing bores are checked with “go” and “no go” plug gages. The “go” gage size is the minimum diameter inside the needle rollers. The “no go” gage size is 0.0001 in. larger than the maximum diameter inside the needle rollers.

Procedures for selecting ring and plug gage dimensions are the same as for those involving precision needle bearings, except that the ring gage diameters and diameters inside the needle rollers must be drawn from the table on this page.

GAGING			
Nominal shaft diameter inch	Ring gage	Diameter inside needle rollers (F <sub>ws min</sub> )	
		Min.	Max.
		1/8	0.2473
5/32	0.2785	0.1569	0.1573
3/16	0.3390	0.1881	0.1885
1/4	0.4328	0.2506	0.2510
5/16	0.4953	0.3131	0.3135
H 5/16	0.5578	0.3756	0.3760
H 3/8	0.6203	0.4381	0.4385
H 7/16	0.6828	0.5006	0.5010
H 1/2	0.7453	0.5631	0.5635
H 9/16	0.8078	0.6256	0.6260
H 5/8	0.8703	0.6881	0.6885
H 11/16	0.9328	0.7506	0.7510
H 3/4	0.9953	0.8131	0.8135
H 7/8	1.0578	0.8756	0.8760
H 15/16	1.1203	0.9381	0.9385
H 1	1.1828	1.0006	1.0010
H 1 1/16	1.2453	1.0631	1.0635
H 1 1/8	1.3078	1.1256	1.1260
H 1 1/4	1.3703	1.1881	1.1885
H 1 3/8	1.4328	1.2506	1.2510
H 1 1/2	1.4953	1.3131	1.3135
H 1 5/8	1.5578	1.3756	1.3760
H 1 3/4	1.6203	1.4381	1.4385
H 1 7/8	1.6828	1.5006	1.5010
H 2	1.7453	1.5631	1.5635
H 2 1/16	1.8078	1.6256	1.6260
H 2 1/8	1.8703	1.6881	1.6885
H 2 1/4	1.9328	1.7506	1.7510
H 2 3/8	1.9953	1.8131	1.8135
H 2 1/2	2.0578	1.8756	1.8760
H 2 5/8	2.1203	1.9381	1.9385
H 2 3/4	2.1828	2.0006	2.0010
H 2 7/8	2.2453	2.0631	2.0635
H 3	2.3078	2.1256	2.1260
H 3 1/8	2.3703	2.1881	2.1885
H 3 1/4	2.4328	2.2506	2.2510
H 3 3/8	2.4953	2.3131	2.3135
H 3 1/2	2.5578	2.3756	2.3760
H 3 3/4	2.6203	2.4381	2.4385
H 3 7/8	2.6828	2.5006	2.5010
H 4	2.7453	2.5631	2.5635
H 4 1/16	2.8078	2.6256	2.6260
H 4 1/8	2.8703	2.6881	2.6885
H 4 1/4	2.9328	2.7506	2.7510
H 4 3/8	2.9953	2.8131	2.8135
H 4 1/2	3.0578	2.8756	2.8760
H 4 5/8	3.1203	2.9381	2.9385
H 4 3/4	3.1828	3.0006	3.0010
H 4 7/8	3.2453	3.0631	3.0635
H 5	3.3078	3.1256	3.1260
H 5 1/8	3.3703	3.1881	3.1885
H 5 1/4	3.4328	3.2506	3.2510
H 5 3/8	3.4953	3.3131	3.3135
H 5 1/2	3.5578	3.3756	3.3760
H 5 3/4	3.6203	3.4381	3.4385
H 5 7/8	3.6828	3.5006	3.5010
H 6	3.7453	3.5631	3.5635

MOUNTING DESIGNS - continued

NEEDLE ROLLER CAGE ASSEMBLIES

Metric series needle roller and cage radial assemblies are supplied with needle roller complements subdivided into groups (gages) shown in Table 16. The groups are at Timken’s option if nothing to the contrary is agreed upon at the time of ordering. This is in accordance with Grade G2 specified in ISO 3096 standard. The group limits of the needle rollers are indicated on the package. Labels of identifying colors show the group limits of the needle rollers. The needle roller and cage assemblies of one shipment usually contain needle rollers with group limits of between 0 to -2, and -5 to -7  $\mu\text{m}$  (colors red, blue and white). Information on needle roller and cage assemblies with needle rollers of different group limits will be supplied on request.

TABLE 16

NEEDLE ROLLER GROUP LIMITS (GRADE G2)		
Group Tolerance $\mu\text{m}$	Marking	Identifying color of label or on package
0 -2	P0M2	
-1 -3	M1M3	red
-2 -4	M2M4	
-3 -5	M3M5	blue
-4 -6	M4M6	
-5 -7	M5M7	white (gray)
-6 -8	M6M8	
-7 -9	M7M9	green
-8 -10	M8M10	
-9 -11	M9M11	yellow

In the marking of the gages, P identifies zero (0) or plus (+), M identifies minus (-).

The nominal inch assemblies, WJ and WJC, contain needle rollers manufactured to only one diameter grade. Within any one assembly, the needle rollers have a total diameter tolerance of .0001 inch.

The limit to precision of the radial clearance of mounted needle roller and cage assemblies is the capability of the user to hold close tolerances on the inner and outer raceways.

The tolerance of the overall width of these assemblies is given on the tabular pages of this section.

It may be impractical to finish the shaft to meet desired raceway design requirements. In this case, standard needle roller bearings with inner rings (forming complete bearings) will have to be used. Such bearings meet the quality requirements in accordance with ISO standards.

- For inner and outer ring tolerances the metric series bearings follow the normal tolerance class in ISO Standard 492 covering radial bearings. Bearings to more precise tolerance classes P6 and P5 may be obtained upon request.
- The metric series bearings may be obtained with radial internal clearance in accordance with ISO Standard 5753 also specified for cylindrical roller bearings. Mostly, they follow the normal (C0) radial clearance group although bearings to clearance groups C2, C3, and C4 may be made available on request.
- Inner ring and outer ring chamfer dimensions meet the requirements of ISO Standard 582.

Whenever the shaft can be used as the inner raceway, needle roller bearings without inner rings provide advantages of economy and close control of radial internal clearance in operation. Tolerance class F6 is the normal specification for the metric series needle roller complement bore diameter of an unmounted bearing as shown in the following table. In the case of needle roller bearings of series RNAO, without flanges and without inner rings, the outer rings and needle roller and cage assemblies are not interchangeable.

METRIC SERIES NEEDLE ROLLER COMPLEMENT BORE DIAMETER FOR BEARINGS WITHOUT INNER RINGS			
$F_w$ mm		$\Delta F_{ws \text{ min}}$ $\mu\text{m}$	
>	$\leq$	low	high
3	6	+10	+18
6	10	+13	+22
10	18	+16	+27
18	30	+20	+33
30	50	+25	+41
50	80	+30	+49
80	120	+36	+58
120	180	+43	+68
180	250	+50	+79
250	315	+56	+88
315	400	+62	+98



**MOUNTING DESIGNS - continued**

Alternatively, for inch designs the tolerances for the HJ bearings are given in Tables 17 and 18 and tolerances for the IR inner rings are given in Table 19 and 20.

**TABLE 17**

OUTSIDE DIAMETER AND WIDTH TOLERANCES, HJ BEARINGS						
D Nominal Outside Diameter		Deviations from Nominal				
		of Single Mean Outside Diameter, $D_{mp}^{(1)}$			of Width, C	
inch	inch	inch			inch	
>	≤	high	low	high	low	low
0.7500	2.0000	0	-0.0005	0		-0.005
2.0000	3.2500	0	-0.0006	0		-0.005
3.2500	4.7500	0	-0.0008	0		-0.005
4.7500	7.2500	0	-0.001	0		-0.005
7.2500	10.2500	0	-0.0012	0		-0.005
10.2500	12.5000	0	-0.0014	0		-0.005

<sup>(1)</sup>“Single mean diameter” is defined as the mean diameter in a single radial plane.

**TABLE 18**

ROLLER COMPLEMENT BORE TOLERANCE, HJ BEARINGS				
$F_w$ Nominal Roller Complement Bore Diameter		Deviations from Nominal of the Smallest Single Diameter <sup>(1)</sup> of the Roller Complement Bore, $F_{ws\ min}$		
inch		inch		
>	≤	low	high	high
0.5000	0.6250	+0.0008		+0.0017
0.6250	1.1250	+0.0009		+0.0018
1.1250	1.6250	+0.0010		+0.0019
1.6250	1.8750	+0.0010		+0.0020
1.8750	2.7500	+0.0011		+0.0021
2.7500	3.0000	+0.0011		+0.0023
3.0000	4.0000	+0.0012		+0.0024
4.0000	4.5000	+0.0012		+0.0026
4.5000	6.0000	+0.0013		+0.0027
6.0000	6.5000	+0.0013		+0.0029
6.5000	7.7500	+0.0014		+0.0030
7.7500	9.2500	+0.0014		+0.0032

<sup>(1)</sup> “The smallest single diameter of the roller complement bore” is defined as the diameter of the cylinder which, when used as a bearing inner ring, results in zero radial internal clearance in the bearing on at least one diameter.

TABLE 19

BORE AND WIDTH TOLERANCES, IR INNER RINGS						
d		Deviations from Nominal				
Nominal Outside Diameter		of Single Mean Outside Diameter, $d_{mp}^{(1)}$			of Width, B	
inch	inch	inch		inch		
>	≤	high	low	high	low	
0.3125	0.7500	0	-0.0004	+0.010	+0.005	
0.7500	2.0000	0	-0.0005	+0.010	+0.005	
2.0000	3.2500	0	-0.0006	+0.010	+0.005	
3.2500	4.2500	0	-0.0008	+0.015	+0.005	
4.2500	4.7500	0	-0.0008	+0.015	+0.010	
4.7500	7.0000	0	-0.001	+0.015	+0.010	
7.0000	8.0000	0	-0.0012	+0.015	+0.010	

<sup>(1)</sup>“Single mean diameter” is defined as the mean diameter in a single radial plane.

TABLE 20

OUTSIDE DIAMETER TOLERANCE, IR INNER RINGS				
F		Deviations from Nominal		
Nominal Outside Diameter		of Single Mean Outside Diameter, $F_{mp}^{(1)}$		
inch		inch		
>	≤	high	low	
0.5000	0.6250	-0.0005	-0.0009	
0.6250	1.0000	-0.0007	-0.0012	
1.0000	1.1250	-0.0009	-0.0014	
1.1250	1.3750	-0.0009	-0.0015	
1.3750	1.8750	-0.0010	-0.0016	
1.8750	3.0000	-0.0011	-0.0018	
3.0000	3.7500	-0.0013	-0.0022	
3.7500	4.5000	-0.0015	-0.0024	
4.5000	5.5000	-0.0015	-0.0025	
5.5000	6.5000	-0.0017	-0.0027	
6.5000	8.2500	-0.0019	-0.0031	
8.2500	9.2500	-0.0020	-0.0032	

<sup>(1)</sup>“Single mean diameter” is defined as the mean diameter in a single radial plane.

MOUNTING DESIGNS - *continued*

## NEEDLE ROLLER BEARINGS

## BEARINGS WITHOUT INNER RINGS

When the shaft is used as the inner raceway for needle roller bearings it must have a hardness between 58 and 64 HRC and a wave-free finish in order to realize the full load-carrying capability of the bearing.

- 1. Metallurgy** – either case hardening or through hardening grades of good bearing quality steel are satisfactory for raceways. Steels which are modified for free machining, such as those high in sulfur content and particularly those containing lead, are seldom satisfactory for raceways. To realize full bearing capacity, the raceway area must be at least surface hard with a reasonable core strength. It is preferred that the case depth be not less than 0.42 mm (0.015 inches). The preferred surface hardness is equivalent to 58 HRC. If the raceway is of lesser hardness, see the modification factors shown on pages A39 and A34. The minimum effective case depth of hardened and ground raceways, for use with all types of needle roller bearings, depends on the applied load, the diameter of the rolling elements and the core strength of the steel used. To calculate the approximate case depth the following formula may be used:

$$\text{Min case depth} = (0.07 \text{ to } 0.12) \cdot D_w$$

$D_w$  is the diameter of the rolling element.

The high value should apply to a low core strength material and/or heavy loads.

Note – The effective case is defined as the distance from the surface, after final grind, to the 50 HRC hardness level.

- 2. Strength** – the shaft must be of sufficient size to keep the operating deflections within the limits outlined.
- 3. Tolerance** – the suggested shaft diameter tolerances for each type of needle roller bearing are indicated in the appropriate section of this catalog.
- 4. Variation of mean shaft diameter** – within the length of the bearing raceway should not exceed 0.008 mm (0.0003 inches), or one-half the diameter tolerance, whichever is smaller.

## BEARINGS WITH INNER RINGS

When it is undesirable or impractical to prepare the shaft to be used as a raceway, inner rings are available as listed in the tabular pages. If the shaft is not used directly as a raceway, the following design specifications must be met:

- 1. Strength** – the shaft must be of sufficient size to keep the operating deflections within the limits outlined.
- 2. Tolerance** – the suggested shaft diameter tolerances for each type of needle roller bearing are indicated in the appropriate section of the catalog.

- 5. Deviation from circular form** – the radial deviation from true circular form of the raceway should not exceed 0.0025 mm (0.0001 inches) for diameters up to and including 25 mm (1.0 inches). For raceways greater than 25 mm (1.0 inches) the allowable radial deviation should not exceed 0.0025 mm (0.0001 inch) multiplied by a factor of the raceway diameter divided by 25 for mm (1.0 for inches).
- 6. High frequency lobing** – the lobing which occurs 10 or more times around the circumference of a shaft and exceeds 0.4  $\mu\text{m}$  (15 microinches) peak-to-valley is defined as chatter. Chatter usually causes undesirable noise and reduces fatigue life.
- 7. Surface finish** – In addition to a wave-free finish the raceway surface roughness of  $R_a \leq 0.2 \mu\text{m}$  (8.0 microinches) must be maintained for the bearing to utilize its full load rating. The raceway area must also be free of nicks, burrs, scratches and dents. Oil holes are permissible in the raceway area but care must be taken to blend the edges gently into the raceway, and if possible, the hole should be located in the unloaded zone of the raceway. Care must also be taken to prevent grind reliefs, fillets, etc., from extending into the raceway area. If the rollers overhang a grind relief or step on the shaft, there will be high stress concentration with resultant early damage.
- 8. End chamfer** – for the most effective assembly of the shaft into a bearing, the end of the shaft should have a large chamfer or rounding. This should help in preventing damage to the roller complement, scratching of the raceway surface and nicking of the shaft end.
- 9. Sealing surface** – in some instances bearings have integral or immediately adjacent seals that operate on the surface ground for the bearing raceway. Here, particular attention should be paid to the pattern of the shaft finish. In no instance should there be a “lead” or spiral effect, as often occurs with through feed centerless grinding. Such a “lead” may pump lubricant past the seal.

- 3. Variation of mean shaft raceway diameter and deviation from circular form of the raceway** – should not exceed one-half the shaft diameter tolerance.
- 4. Surface finish** – the surface finish should not exceed  $R_a 1.6 \mu\text{m}$  (63 microinches).
- 5. Locating shoulders or steps** – locating shoulders or steps in the shaft must be held to close concentricity with the bearing seat to prevent imbalance and resultant vibrations.

MOUNTING DESIGNS - *continued***NEEDLE ROLLER BEARINGS  
BEARINGS WITH OUTER RINGS**

For bearings with outer rings, the function of the housing is to locate and support the outer ring. The following specifications must be met:

- 1. Strength** – housings should be designed so that the radial loads, which will be placed on the bearings, will cause a minimum of deflection or distortion of the housing.
- 2. Variation of mean housing diameter** – within the length of the outer ring should not exceed 0.013 mm (0.0005 inches).
- 3. Deviation from circular form** – the housing bore should be round within one-half the housing bore tolerance.
- 4. Parallelism** – when possible, line bore housings which are common to one shaft to obtain parallelism of the housing bores and the shaft axis.
- 5. Surface finish** – The surface finish should not exceed  $R_a$  1.6  $\mu\text{m}$  (63 microinches).
- 6. End chamfer** – to permit easy introduction of the bearing into the housing, the end of the housing should have a generous chamfer.

**Needle roller bearings** can be installed into housings with a transition fit or a clearance fit. The outer ring should be a transition fit in the housing when it rotates relative to the load. The outer ring may be a clearance fit in the housing when it is stationary relative to the load in either case, locate the bearings by shoulders, or other locating devices, to prevent axial movement.

Since the needle roller bearing does not require an interference fit in the housing to round and size it properly, a split housing may be used if desired. Dowels should be used to maintain proper register of the housing sections.

**Drawn cup bearings** have a thin case-hardened outer ring which is out-of-round from the hardening operation. For proper mounting it must **always** be pressed into the housing. Split housings will not round and size a drawn cup bearing. When split housings must be used, the bearing should first be mounted in a cylindrical sleeve.

The housing should be of sufficient tensile strength and section to round and size the bearing. It must be designed for minimum distortion under load. Steel or cast iron housings are preferred. Housing bores in low tensile strength materials such as aluminum, magnesium, phenolics, etc., should be reduced to provide more interference fit. Thin section cast iron and steel housings may also require reduced bores. Consult your Timken representative for suggestions when working with these lower strength housings.

The housing should be through-bored if possible. When shouldered housing bores are unavoidable, the bearing should be located far enough from the shoulder to avoid the danger of crushing the end of the drawn cup during installation.

When the drawn cup bearing is mounted close to the housing face, care should be taken to mount the bearing at least 0.25 mm (0.010 inches) within the housing face to protect the bearing lip.

**BEARINGS WITHOUT OUTER RINGS**

In many cases, such as with gear bores, it is desirable to have the housing bore serve as the outer raceway for radial needle roller and cage assemblies or loose needle roller complements. In those instances, as for shafts used as a raceway, the housing bore must have a hardness between 58 and 64 HRC and a roughness  $R_a \leq 0.2 \mu\text{m}$  (8.0 microinches), so that the full load carrying capacity of the bearing is realized.

- 1. Strength** – the housing must be of sufficient cross section to maintain proper roundness and running clearance under maximum load.
- 2. Metallurgical** – material selection, hardness and case depth should be consistent with the requirements for inner raceways given in the shaft design.

- 3. Variation of mean housing raceway diameter and deviation from circular form of the raceway** – the raceway out-of-roundness and taper should not exceed 0.008 mm (0.0003 inches) or one-half the bore tolerance, whichever is smaller. In addition, the bore diameter must never be smaller at both ends than in the center [sway-back].

- 4. Surface finish** – In addition to a wave-free finish, the raceway surface roughness of  $R_a \leq 0.2 \mu\text{m}$  (8.0 microinches) must be maintained for the bearing to utilize its full load rating. The raceway area must also be free of nicks, burrs, scratches and dents.

- 5. Grind reliefs** – care must be exercised to ensure that grind reliefs, fillets, etc. do not extend to the raceway. Oil holes in the raceway area are permissible, but the edges must be blended smoothly with the raceway, and if possible, the hole should be located in the unloaded zone of the raceway.



MOUNTING DESIGNS - *continued***ADDITIONAL DETAILS ABOUT DRAWN CUP NEEDLE BEARINGS**

Drawn cup bearings are manufactured to a degree of precision that will satisfy the radial clearance requirements of most applications. The total radial clearance for an installed drawn cup bearing results from the build up of manufacturing tolerances of the housing bore, the inner raceway diameter and the bearing, as well as the minimum radial clearance required for the application.

For metric series drawn cup bearings requiring close control of radial internal clearance the suggested housing bore tolerance is N6 and h5 tolerance for the inner raceway diameter. When such exacting close control of radial internal clearance is not required, the user may select N7 housing bore and h6 inner raceway diameter tolerances.

For metric series drawn cup bearings used in housings made from materials of low rigidity or steel housings of small section the suggested housing bore tolerance is R6 (R7). To maintain normal radial internal clearance the inner raceway diameter tolerance should be h5 (h6).

For metric series drawn cup bearing applications where the outer ring rotates with respect to the load, it is suggested that both the housing bore and the inner raceway diameter be reduced using R6 (R7) and f5 (f6) tolerance practice respectively.

Metric series drawn cup bearing applications involving oscillating motion may require reduced radial internal clearances. This reduction may be accomplished by increasing the inner raceway diameter using j6 tolerance.

When it becomes impractical to meet the shaft raceway design requirements (hardness, case depth, surface finish etc.) outlined in this section, standard inner rings may be used with metric series drawn cup bearings. It is suggested that when metric series inner rings are used with metric series drawn cup bearings, they should be mounted with a loose transition fit on the shaft using g6 (g5) shaft diameter tolerance. The inner ring should be endclamped against a shoulder. If a tight transition fit must be used, [shaft diameter tolerance h6 (h5)], to keep the inner ring from rotating relative to the shaft, the inner ring outside diameter, as mounted, must not exceed the raceway diameter required by the drawn cup bearing for the particular application. In case the outside diameter of the inner ring, when mounted on the shaft, exceeds the required raceway diameter for the matching drawn cup bearing, it should be ground to proper diameter while mounted on the shaft.

Inch drawn cup needle roller bearings utilize the standard tolerance scheme outlined in the following figure.

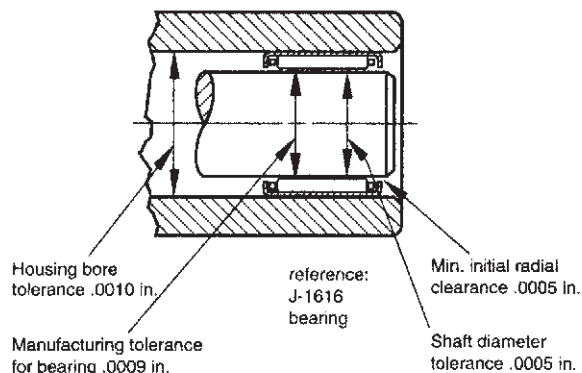

Fig. A-14

**MOUNTING DESIGNS - continued**

For housing materials of low rigidity or steel housings of small section, it is suggested that for initial trial the housing bore diameters given in the tabular pages be reduced by the amounts shown in Table 21. To maintain normal radial internal clearance, the inner raceway diameter tolerance given in the tabular pages should be used.

**TABLE 21**

LOW RIGIDITY HOUSING BORE		
Nom. Housing Bore Inch		Subtract Inch
over	incl.	
0	.38	.0004
.38	1.00	.0006
1.00	2.00	.0010
2.00	3.00	.0012
3.00	6.00	.0014

For applications where the outer ring rotates with respect to the load, it is suggested that both the housing bore and inner raceway diameter be reduced. Bearings of nominal inch dimensions should have the housing bore and inner raceway diameters reduced by .0005".

Applications involving oscillating motion often require reduced radial clearances. This reduction is accomplished by increasing the shaft raceway diameters as shown in Table 22.

**TABLE 22**

NOMINAL INCH BEARING OSCILLATING SHAFT SIZE	
Shaft Size	Add
inch	inch
.094 to .188	.0003
.25 to 1.875	.0005
2 to 5.5	.0006

Where it becomes impractical to meet the shaft raceway design requirements (hardness, case depth, surface finish, etc.) standard inner rings for inch drawn cup bearings are available.

Inner rings for inch drawn cup bearings are designed to be a loose transition fit on the shaft and should be clamped against a shoulder. If a tight transition fit must be used to keep the inner ring from rotating relative to the shaft, the inner ring O.D., as mounted, must not exceed the raceway diameters required by the drawn cup bearing for the particular application. See the previous discussion on internal clearances and fits for further details on inner raceway diameter choice.

**EXTRA-PRECISION INCH DRAWN CUP NEEDLE ROLLER BEARINGS**

MOUNTING						
Basic Bore Designation	Nominal Bore Inch	Nominal O.D.	Shaft Raceway Diameter		Housing Bore	
			Max.	Min.	Min.	Max.
GB-2	.1250	.2500	0.1251	0.1248	0.2470	0.2473
GB-2 1/2	.1562	.2812	0.1564	0.1561	0.2782	0.2785
GB-3	.1875	.3438	0.1876	0.1873	0.3387	0.3390
GB-4	.2500	.4375	0.2501	0.2498	0.4325	0.4328
GB-5	.3125	.5000	0.3126	0.3123	0.4950	0.4953
GBH-5	.3125	.5625	0.3126	0.3123	0.5575	0.5578
GB-6	.3750	.5625	0.3751	0.3748	0.5575	0.5578
GBH-6	.3750	.6250	0.3751	0.3748	0.6200	0.6203
GB-7	.4375	.6250	0.4376	0.4373	0.6200	0.6203
GBH-7	.4375	.6875	0.4376	0.4373	0.6825	0.6828
GB-8	.5000	.6875	0.5001	0.4998	0.6825	0.6828
GBH-8	.5000	.7500	0.5001	0.4998	0.7450	0.7453
GB-9	.5625	.7500	0.5626	0.5623	0.7450	0.7453
GBH-9	.5625	.8125	0.5626	0.5623	0.8075	0.8078
GB-10	.6250	.8125	0.6251	0.6248	0.8075	0.8078
GBH-10	.6250	.8750	0.6251	0.6248	0.8700	0.8703
GB-11	.6875	.8750	0.6876	0.6873	0.8700	0.8703
GBH-11	.6875	.9375	0.6876	0.6873	0.9325	0.9328
GB-12	.7500	1.0000	0.7501	0.7498	0.9950	0.9953
GBH-12	.7500	1.0625	0.7501	0.7498	1.0575	1.0578
GB-13	.8125	1.0625	0.8126	0.8123	1.0575	1.0578
GBH-13	.8125	1.1250	0.8126	0.8123	1.1200	1.1203
GB-14	.8750	1.1250	0.8751	0.8748	1.1200	1.1203
GBH-14	.8750	1.1875	0.8751	0.8748	1.1825	1.1829
GB-15	.9375	1.1875	0.9376	0.9373	1.1825	1.1829
GB-16	1.0000	1.2500	1.0001	0.9998	1.2450	1.2454
GBH-16	1.0000	1.3125	1.0001	0.9998	1.3075	1.3079
GB-17	1.0625	1.3125	1.0626	1.0623	1.3075	1.3079
GB-18	1.1250	1.3750	1.1251	1.1248	1.3700	1.3704
GBH-18	1.1250	1.5000	1.1251	1.1248	1.4950	1.4955
GB-19	1.1875	1.5000	1.1876	1.1873	1.4950	1.4955
GB-20	1.2500	1.5000	1.2501	1.2498	1.4950	1.4955
GBH-20	1.2500	1.6250	1.2501	1.2498	1.6200	1.6205
GB-21	1.3125	1.6250	1.3126	1.3123	1.6200	1.6205
GB-22	1.3750	1.6250	1.3750	1.3747	1.6200	1.6205
GBH-22	1.3750	1.7500	1.3750	1.3747	1.7450	1.7455
GB-24	1.5000	1.8750	1.5000	1.4997	1.8700	1.8705
GB-26	1.6250	2.0000	1.6250	1.6247	1.9950	1.9955
GB-28	1.7500	2.1250	1.7500	1.7497	2.1200	2.1205
GB-30	1.8750	2.2500	1.8750	1.8747	2.2450	2.2455
GB-32	2.0000	2.3750	2.0000	1.9997	2.3700	2.3705
GBH-33	2.0625	2.5312	2.0624	2.0621	2.5262	2.5267
GB-34	2.1250	2.5000	2.1249	2.1246	2.4950	2.4955
GB-36	2.2500	2.6250	2.2499	2.2496	2.6200	2.6205
GB-42	2.6250	3.0000	2.6248	2.6245	2.9950	2.9956
GB-44	2.7500	3.1250	2.7498	2.7495	3.1200	3.1206
GB-56	3.5000	4.0000	3.4998	3.4995	3.9950	3.9956

\* Check for availability - not every size may be in production.



MOUNTING DESIGNS - continued

**DRAWN CUP NEEDLE ROLLER BEARINGS – INCH**

**Installation of closed end bearings**

The installation tool combines all the features of the tool used to install open end bearings, but the pilot is spring-loaded and is part of the press bed.

The angled shoulder of the pressing tool should bear against the closed end with the bearing held on the pilot to aid in starting the bearing true in the housing.

- A – 1/64 in. less than housing bore
- B – .003 in. less than shaft diameter
- C – distance bearing will be inset into housing, minimum of .008 in.

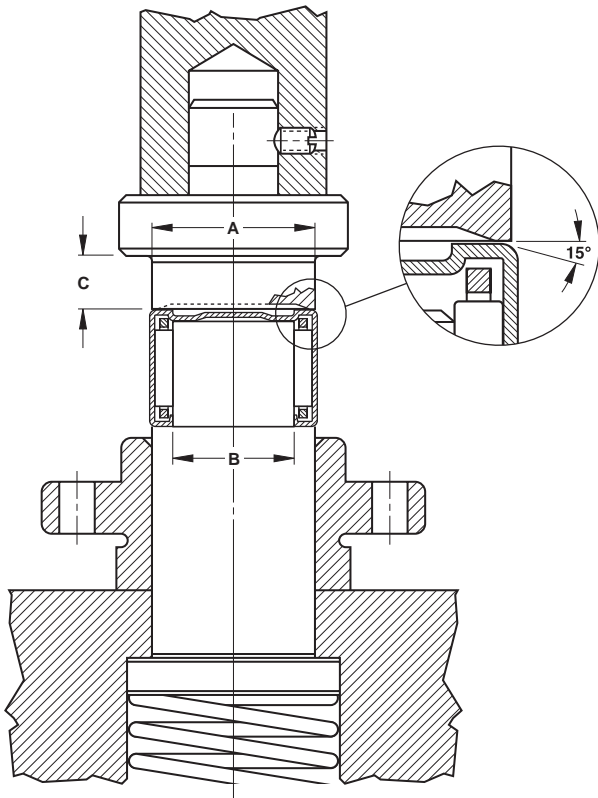

**Extraction of drawn cup bearings**

The need to extract a drawn cup bearing does not arise often. Standard extractor tools may be purchased from a reputable manufacturer. Customers may produce the special extraction tools at their own facilities. After extraction, the drawn cup bearing should not be reused.

**Extraction from a straight housing**

When it is necessary to extract a drawn cup bearing from a straight housing, a similar tool to the installation tool, but without the stop, may be used. To avoid damage to the bearing, pressure should be applied against the stamped end of the bearing, just as it is done at installation.

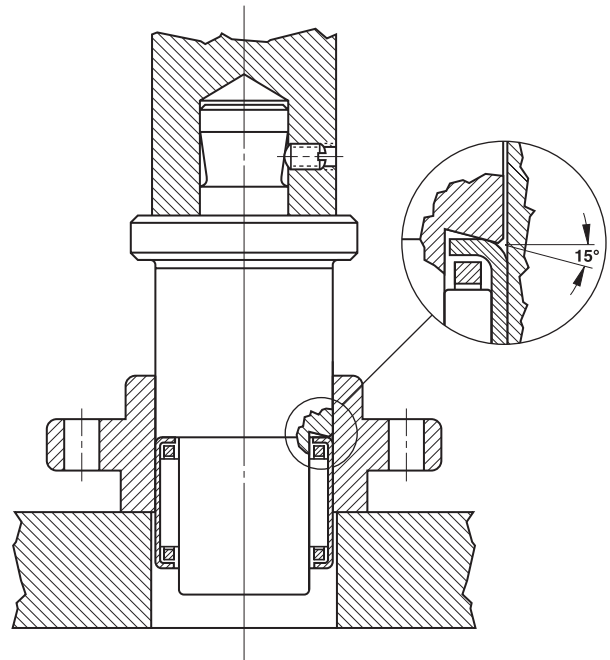

**MOUNTING DESIGNS - continued****DRAWN CUP NEEDLE ROLLER BEARINGS**  
**Extraction from a shouldered or dead-end housing (with space between the bearing and the housing shoulder)**

Bearings may be extracted from shouldered or dead-end housings with a common bearing puller tool as shown. This type of tool is slotted in two places at right angles to form four prongs. The four puller prongs are pressed together and inserted into the space between the end of the bearing and the shoulder. The prongs are forced outward by inserting the expansion rod, and then the bearing is extracted. Do not reuse the bearing after extraction.

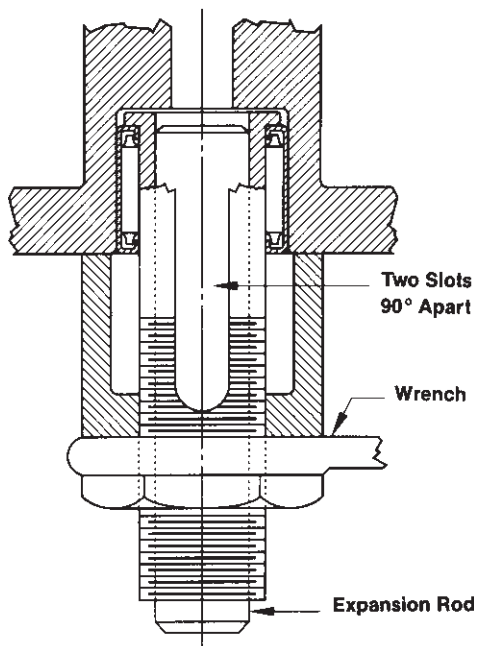
**Extraction from a shouldered housing (with bearing pressed up close to the shoulder)**

The tool to be used, as shown, is of a similar type described for a shouldered or dead-end housing, but the rollers must first be removed from the bearing.

The four segment puller jaws are collapsed and slipped into the empty cup. The jaws are then forced outward into the cup bore by means of the tapered expansion rod. The jaws should bear on the lip as near as possible to the cup bore. The cup is then pressed out from the top.

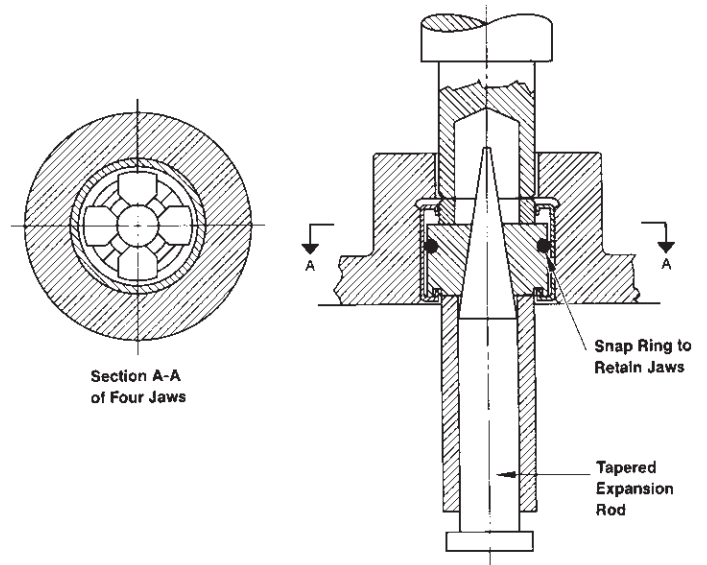

MOUNTING DESIGNS - continued

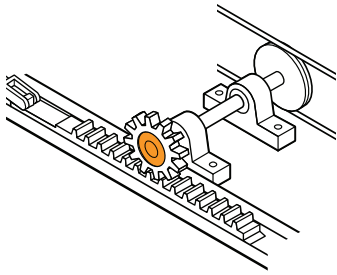

Rack Indexing Drive

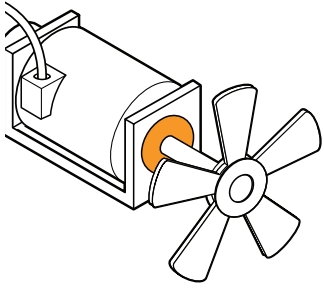

Motor Backstops

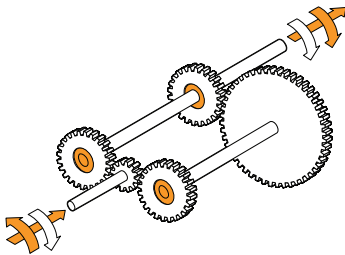

2-Speed Gearbox with Reversing Input

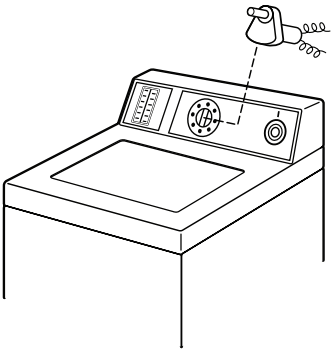

Timing Motor Freewheels

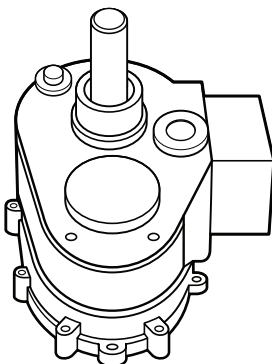

Washing Machine Transmission

**DRAWN CUP ROLLER CLUTCHES**

**Housing design**

Drawn cup clutches and clutch and bearing assemblies are mounted with a simple press fit in their housings. Through bored and chamfered housings are preferred. Provisions for axial location, such as shoulders or snap rings, are not required. The case hardened cups must be properly supported. Steel housings are preferred and must be used for applications involving high torque loads to prevent radial expansion of the clutch cups. The suggested minimum housing outside diameters in the tables of dimensions are for steel.

The housing bore should be round within one-half of the diameter tolerance. The taper within the length of the outer ring should not exceed 0.013 mm or 0.0005 inch.

The surface finish of the housing bore should not exceed 63 microinches, a.a. (arithmetic average) or 1.6 μm (on the Ra scale).

Low strength housings (non-steel, sintered metals and some plastics) may be entirely satisfactory in lightly loaded applications. When using non-steel housings, thoroughly test designs.

Adhesive compounds can be used to prevent creeping rotation of the clutch in plastic housings with low friction properties. Adhesives will not provide proper support in oversized metallic housings. When using adhesives, care must be taken to keep the adhesive out of the clutches and bearings.

**Shaft design**

The clutch or bearing assembly operates directly on the shaft whose specifications of dimensions, hardness and surface finish are well within standard manufacturing limits.

Either case hardening or through hardening grades of good bearing quality steel are satisfactory for raceways. Steels which are modified for free machining, such as those high in sulfur content and particularly those containing lead, are seldom satisfactory for raceways.

For long fatigue life, the shaft raceway, must have a hardness equivalent to 58 HRC (ref, ASTM E-18), and ground to the suggested diameter shown in the tables of dimensions. It may be through hardened, or it may be case hardened, with an effective case depth of 0. mm (0.015 inch) (Effective case depth is defined as the distance from the surface inward to the equivalent of 50 HRC hardness level after grinding.)

Taper within the length of the raceway should not exceed 0.008 mm (0.0003 inch), or one-half the diameter tolerance, whichever is smaller. The radial deviation from true circular form of the raceway should not exceed 0.0025 mm (.0001 inch) for diameters up to and including 25.4 mm (1 inch). For raceways greater than 25 mm or 1.0 inch the allowable radial deviation may be greater than 0.0025 mm (.0001 inch) by a factor of raceway diameter (in inches) divided by 1.0 or a factor of raceway diameter (in mm) divided by 25.4. Surface finish on the raceway should not exceed 16 microinches a.a. (arithmetic average) or 0.4 μm (on the Ra scale). Deviations will reduce the load capacity and fatigue life of the shaft.

MOUNTING DESIGNS - continued

Installation

Simplicity of installation promotes additional cost savings. The drawn cup roller clutch or the clutch and bearing assembly must be pressed into its housing. The unit is pressed into the bore of a gear hub or pulley hub or housing of the proper size and no shoulders, splines, keys, screws or snap rings are required.

Installation procedures are summarized in the following sketches:

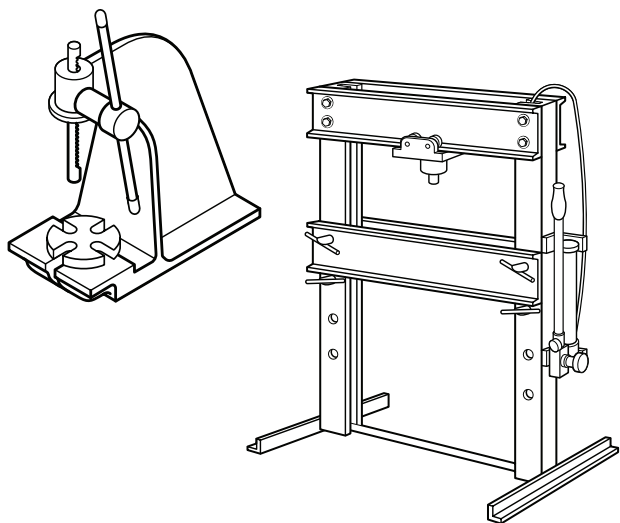

Use an arbor press or hydraulic ram press which will exert steady pressure. Never use a hammer or other tool requiring pounding to drive the clutch into its housing.

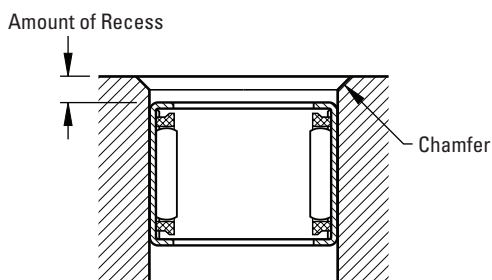

Make sure that the housing bore is chamfered to permit easy introduction of the clutch and bearing or the clutch unit. Press unit slightly beyond the chamfer in the housing bore to assure full seating. Through bored housings are always preferred. If the housing has a shoulder, never seat the clutch against the shoulder.



**IMPORTANT:** The mounted clutch or clutch and bearing assembly engages when the housing is rotated relative to the shaft in the direction of the arrow and LOCK marking (←LOCK) stamped on the cup. Make sure that the unit is oriented properly before pressing it into its housing.

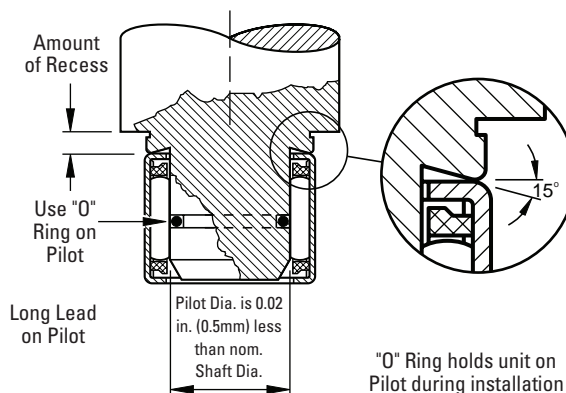

Use an installation tool as shown in the diagram above. If clutch is straddled by needle roller bearings, press units into position in proper sequence and preferably leave a small clearance between units.

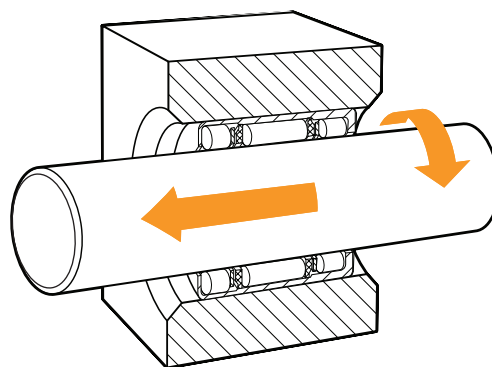

When assembling the shaft, it should be rotated during insertion. The end of the shaft should have a large chamfer or rounding.



MOUNTING DESIGNS - continued

**RADIAL NEEDLE ROLLER AND CAGE ASSEMBLIES – METRIC**

Radial needle roller and cage radial assemblies use the housing bore as the outer raceway and the shaft as the inner raceway. In order to realize full bearing load rating, the housing bore and the shaft raceways must have the correct geometric and metallurgical characteristics. The housing should be of sufficient cross section to maintain adequate roundness and running clearance under load. The only limit to precision of the radial clearance of a mounted assembly is the capability of the user to hold close tolerances on the inner and outer raceways. The suggested shaft tolerances listed in Table 23 are based on housing bore tolerance G6 and apply to metric series needle roller and cage radial assemblies with needle rollers of group limits between P0M2 and M5M7. Inch cage and roller assemblies list shaft tolerances in the bearing data tables based on h5 tolerances and housings to G6 tolerances.

TABLE 23

SUGGESTED SHAFT TOLERANCES FOR METRIC BEARINGS USING HOUSING BORES MACHINED TO G6 AS OUTER RACEWAYS		
Nominal shaft diameter in mm	≤ 80	> 80
Radial clearance	Shaft tolerance	
Smaller than normal	j5	h5
Normal	h5	g5
Larger than normal	g6	f6

Needle roller and cage radial assembly must be axially guided by shoulders or other suitable means. The end guiding surfaces should be hardened to minimize wear and must provide sufficient axial clearance to prevent end locking of the assembly. Metric length tolerance H11 is suggested. Inch bearings are designed for minimum 0.008 inch axial clearance.

If end guidance is provided by a housing shoulder at one end and by a shaft shoulder at the other end the shaft must be axially positioned to prevent end locking of needle roller and cage assembly. The housing and shaft shoulder heights should be 70 to 90 percent of the needle roller diameter to provide proper axial guidance.

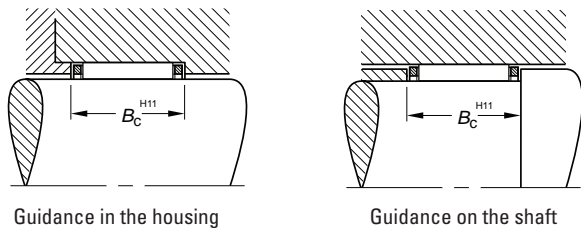

Needle roller and cage radial assemblies which are mounted side by side must have needle rollers of the same group limits to ensure uniform load distribution.

**Connecting rod guidance arrangements**

End guidance of a connecting rod can be provided either at the crank pin or at the wrist pin end. Connecting rod guidance is achieved at the crank pin end using a small clearance between the crank webs. Guidance at the wrist pin end is controlled by a small clearance between the piston bosses.

**Crank pin end guidance**

With crank pin end guidance, care must be taken to ensure that an adequate amount of lubricant is supplied to the crank pin bearing and the surfaces which guide the connecting rod. For this purpose, grooves in the connecting rod end faces or slots in the connecting rod bore aligned with the incoming lubrication path should be provided. Occasionally, brass or hardened steel washers may be used for end guidance of the connecting rod.

At the wrist pin end, the needle roller and cage radial assembly is located axially between the piston bosses. It may be both economical and effective to machine the connecting rod at the wrist pin end and at the crank pin end to the same width. It is suggested that at the wrist pin end, the needle roller length does not overhang the connecting rod width. Otherwise the load rating of the needle roller and cage assembly will be reduced.

**Wrist pin end guidance**

Wrist pin end will get the most effective axial guidance between the piston bosses. Grooves in the bottom of the piston bosses and a chamfer of small angle on each side of the upper portion of the connecting rod small end, can improve the oil flow to the needle roller and cage radial assembly and its guiding surfaces.

The length of the needle roller and cage radial assembly and the connecting rod width at the crank pin end should be identical to ensure best possible radial piloting of cage in the bore of the connecting rod. The crank webs are recessed to allow proper axial alignment of the connecting rod. As a rule it is not necessary to have additional supply of lubricant. Only in engines with sparse lubrication should consideration be given to provide lubricating slots in the connecting rod bores as with crank pin end guidance.

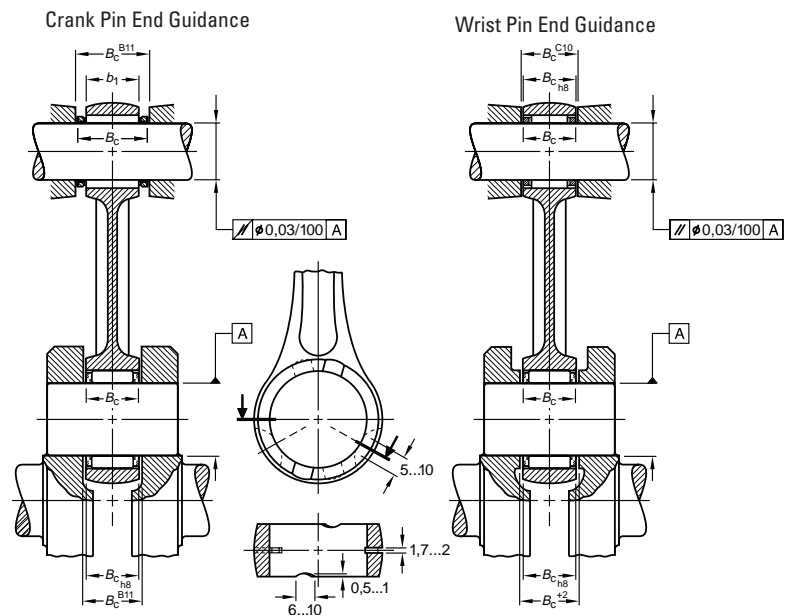





MOUNTING DESIGNS - continued

NEEDLE ROLLER BEARINGS

Heavy-duty needle roller bearings

It is suggested that needle roller bearings are mounted in their housings with a clearance fit if the load is stationary relative to the housing or with a tight transition fit if the load rotates relative to the housing. Table 24 lists the suggested tolerances for the housing bore and the shaft raceway for metric series bearings without inner rings. Table 25 lists the suggested shaft tolerances for the above two mounting conditions when the metric series bearings are used with inner rings. The suggested housing bore tolerances for metric series bearings with inner rings are the same as the housing bore tolerance listed in Table 24 for metric series bearings without inner rings.

The tables of dimensions for inch bearings list the suggested ISO H7 tolerances for the housing bore and the suggested ISO h6 tolerances for the shaft raceway when the outer ring is to be mounted with a clearance fit. They also list the suggested ISO N7 tolerances for the housing bore and the suggested ISO f6 tolerances for the shaft raceway when the outer ring is to be mounted with a tight transition fit.

Other mounting dimensions may be required for special operating conditions such as:

1. Extremely heavy radial loads
2. Shock loads
3. Temperature gradient across bearing
4. Housing material with heat expansion coefficient different than that of the bearing

If these conditions are expected, please consult your Timken representative.

TABLE 24

MOUNTING TOLERANCES FOR METRIC SERIES BEARINGS WITHOUT INNER RING						
Rotation conditions	Nominal housing bore diameter D mm	ISO tolerance zone for housing		Nominal shaft diameter F mm	ISO tolerance zone for shaft	
		caged	full		caged	full
Load stationary relative to housing	all diameters	H7	J6	all diameters	h6	h5
General work with larger clearance	all diameters	K7	—	all diameters	g6	—
Load rotates relative to housing	all diameters	N7	M6	all diameters	f6	g5

NOTE: Care should be taken that the selected bearing internal clearance is appropriate for the operating conditions.

TABLE 25

SHAFT TOLERANCES FOR METRIC SERIES BEARINGS WITH INNER RINGS (USE HOUSING TOLERANCE SHOWN IN TABLE 24)			
Rotation Conditions	Nominal Shaft Diameter d, mm		ISO Tolerance Zone for Shaft
load rotates relative to housing	all diameters		g6
load stationary relative to housing	>	≤	k6
	40	100	m6
	100	140	m6
	140		n6

NOTE: Care should be taken that the selected bearing internal clearance is appropriate for the operating conditions.

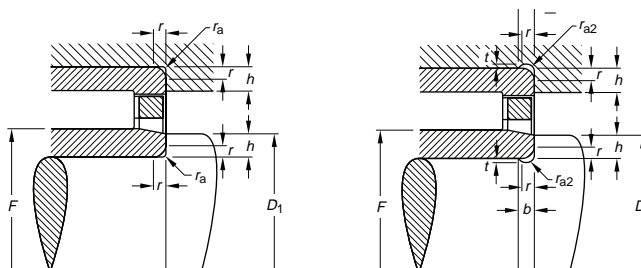

TABLE 26

FILLETS, UNDERCUTS, AND SHOULDER HEIGHTS FOR METRIC SERIES BEARINGS					
$r_s$ Min. mm	$r_{as}$ Max.	t	$r_{a2s}$ Min.	b	h Min.
0.15	0.15				0.6
0.3	0.3				1
0.6	0.6				2
1	1	0.2	1.3	2	2.5
1.1	1	0.3	2	3	3.25
1.5	1.5	0.4	2	3.2	4
2	2	0.5	2.5	4	5
2.1	2.1	0.5	3	4.7	5.5
3	2.5	0.5	3.5	5	36

Regardless of the fit of the bearing outer ring in the housing, the outer ring should be axially located by housing shoulders or other positive means. The bearing rings should closely fit against the shaft and housing shoulders and must not contact the fillet radius. In fact, the maximum shaft or housing fillet  $r_{as\ max}$  should be no greater than the minimum bearing chamfer  $r_{s\ min}$  as shown in Table 26.

In order to permit mounting and dismounting of the shaft, the maximum diameter  $D_1$  in Table 27 must not be exceeded.  $F_w$  is shown in the bearing tables.

For inch bearings, the unmarked end of the outer ring should be assembled against the housing shoulder to assure clearing the maximum housing fillet. Similarly, the unmarked end of the inner ring should be assembled against the shaft shoulder to assure clearing the maximum shaft fillet.

MOUNTING DESIGNS - continued

TABLE 27

SHOULDER DIAMETER D <sub>1</sub> MAX FOR METRIC SERIES BEARINGS						
Dimensions in mm						
Needle roller complement bore diameter F <sub>w</sub>	>	20	20	55	100	250
	≤	20	55	100	250	
Diameter	D <sub>1max</sub>	F <sub>w</sub> -0.3	F <sub>w</sub> -0.5	F <sub>w</sub> -0.7	F <sub>w</sub> -1	F <sub>w</sub> -1.5

Needle roller bearings without flanges of series RNAO and NAO must have the needle roller and cage radial assembly properly end guided by shoulders or other suitable means such as the spring steel washers (SNSH). These end guiding surfaces should be hardened and precision turned or ground to minimize wear and should properly fit against the outer rings and the inner rings to provide the desired end clearance for the needle roller and cage radial assembly.

NEEDLE ROLLER AND CAGE THRUST ASSEMBLIES

On NTA inch type needle roller and cage thrust assemblies the cage bore has a larger contact area and a closer tolerance than the outside diameter. Therefore, bore piloting is preferred for these assemblies. To reduce wear, it is suggested that the piloting surface for the cage be hardened to an equivalent of at least 55 HRC. Where design requirements prevent bore piloting, the NTA needle roller and cage thrust assemblies may be piloted on the outside diameters. It should be noted that the "diameter to clear washer O.D." given in the tabular data is not suitable for outside diameter piloting. For such cases, suitable O.D. piloting dimensions should be determined in consultation with your Timken representative.

On FNT and AXK Series needle roller and cage thrust assemblies, the cage bore has a closer tolerance than the outside diameter, therefore bore piloting is preferred for these assemblies. To reduce wear, it is suggested that the piloting surface for the cage be hardened to an equivalent of at least 55 HRC. Where design requirements prevent bore piloting, the FNT or AXK Series needle roller and cage thrust assemblies may be piloted on the outside diameters. For such cases, suitable O.D. piloting dimensions should be determined. Mounting tolerances are given in the table to the right.

Ideally, a thrust washer should be stationary with respect to, and piloted by, its supporting or backing member, whether or not this is an integral part of the shaft or housing. There should be no rubbing action between the thrust washer and any other machine member. The economics of design, however, often preclude these ideal conditions and thrust washers must be employed in another manner. In such cases, design details should be determined in consultation with your Timken representative.

The mounting tolerances for series AS, LS, WS and GS thrust washers for use with needle roller and cage thrust assemblies are given in the table to the right.

As for the FNT and AXK Series thrust assemblies, to reduce wear, the piloting surface for the thrust washers should also be hardened to an equivalent of at least 55 HRC.

Out of Square Surface

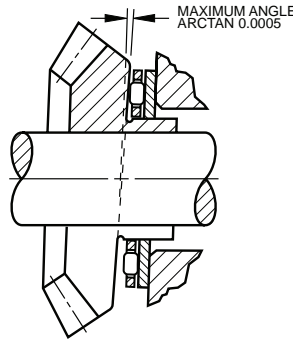

Fig. A-15

Dished or Coned Surface

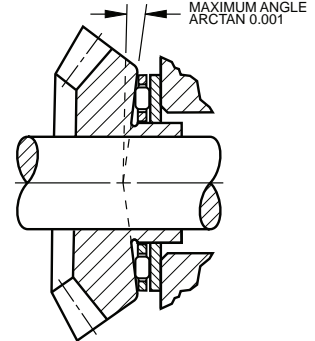

Fig. A-16

MOUNTING TOLERANCES FOR SHAFTS AND HOUSINGS FOR METRIC SERIES COMPONENTS

Bearing components	shaft tolerance	housing tolerance (shaft piloting)	piloting member (housing piloting)
Cylindrical roller & needle roller cage thrust assembly	h8	H10	shaft
Thin thrust washer AS	h10	H11	shaft
Heavy thrust washer LS	h10	H11	shaft
Shaft piloted thrust washer WS.811	h6 (j6)	clearance	shaft
Housing piloted thrust washer GS.811	Clearance	H7 (K7)	housing

In some applications, it is desirable to use the backup surfaces as raceways for the needle rollers of the needle roller and cage thrust assemblies. In such designs, these surfaces must be hardened to at least 58 HRC. If this hardness cannot be achieved and thrust washers cannot be used, the load ratings must be reduced, as explained in the Fatigue Life section.

Thrust raceway surfaces must be ground to a surface finish of 0.2 μm (0.8 μm) R<sub>a</sub>. When this requirement cannot be met, thrust washers must be used.

The raceways against which the needle rollers operate or the surface against which the thrust washers bear must be square with the axis of the shaft. Equally important, the raceway or surface backing the thrust washer, must not be dished or coned. The permissible limits of out-of-squareness and dishing or coning are shown in Figures A-15 and A-16.

Metric raceway contact dimensions E<sub>a</sub> and E<sub>b</sub> are given in the tabular pages. For the thin series AS thrust washers, full backup between the dimensions E<sub>a</sub> and E<sub>b</sub> should be provided.

**MOUNTING DESIGNS - continued****CONSTRUCTION****Basic designs**

Cylindrical roller thrust bearings dimension series 811 and 812 comprise a cylindrical roller and cage thrust assembly (K), a shaft washer (WS) and a housing washer (GS). Providing the backup surfaces can be hardened and ground they can be used as raceways for the cylindrical rollers of the cylindrical roller and cage thrust assembly, resulting in a compact bearing arrangement.

**Cage designs**

Metric series cylindrical roller thrust bearings use molded cages of glass fiber reinforced nylon 6/6 (suffix TVP) or machined cages of light metal (suffix LPB). The cages are designed to be piloted on the shaft. The reinforced nylon cages can be used at temperatures up to 120° C continuously for extended periods. When lubricating these bearings with oil it should be ensured that the oil does not contain additives detrimental to the cage over extended life at operating temperatures higher than 100° C. Also, care should be exercised that oil change intervals are observed as old oil may reduce cage life at such temperatures.

**BEARING THRUST WASHERS****Shaft washers and housing washers**

Shaft washers of types WS.811 and WS.812 as well as housing washers of types GS.811 and GS.812 are components of the metric series cylindrical roller thrust bearings of series 811 and 812. They are made of bearing quality steel, with hardened and precision ground and lapped flat raceway surfaces. The tolerances of the thrust bearing bore and outside diameter shown in Table 7 and Table 8 (on page A47) apply to shaft and housing piloted metric series washers.

**Heavy thrust washers (LS), thin thrust washers (AS)**

These thrust washers, more frequently used with needle roller and cage thrust assemblies of metric series FNT or AXK, are also suitable for use with the cylindrical roller and cage thrust assemblies K.811. The heavy thrust washer of series LS are made of bearing quality steel, hardened and precision ground on the flat raceway surfaces. The bore and outside diameters of the heavy thrust washers are not ground. Therefore, when used with K.811 type assemblies they are only suggested where accurate centering is not required. The thin thrust washers of series AS may be used in applications where the loads are light. Both types of these washers are listed in the tabular part of the metric series needle roller and cage thrust assemblies section.

**MOUNTING DESIGNS** - *continued***DIMENSIONAL ACCURACY**

The tolerances for the metric series cylindrical roller thrust bearing bore and outside diameter shown in Tables 7 and 8 (on page A47) apply to shaft piloted washers of series WS.811 and WS.812 as well as housing piloted washers of series GS.811 and GS.812.

The tolerances for the bore and outside diameter of series AS thrust washers are shown in Table 13. The tolerances for the bore and outside diameter of series LS thrust washers are given in Table 14. Bore inspection procedures for thin thrust washers (AS) and heavy thrust washers (LS) are given on page A50.

**MOUNTING TOLERANCES**

Shaft and housing tolerances for mounting metric series cylindrical roller and cage thrust assemblies are given on page A96. If the cylindrical rollers of the cylindrical roller and cage thrust assemblies are to run directly on the adjacent support surfaces, these must be hardened to at least 58 HRC. Raceway contact dimensions  $E_a$  and  $E_b$  must be observed.

The backup surfaces for the shaft washers WS.811 and WS.812 as well as the housing washers GS.811 and GS.812 of cylindrical roller thrust bearings must be square with the axis of the shaft. Equally important, the raceway or the surface backing the thrust washer must not be dished or coned. The permissible limits of the squareness and dishing or coning are shown in Figures A-15 and A-16. When using the thin (AS) thrust washers the cylindrical rollers of the thrust cage assembly must be supported over their entire length.

Bearing thrust washers should make close contact with the shaft or housing shoulder and must not touch the fillet radius. Therefore, the maximum fillet radius  $r_{as\ max}$  must be no greater than the minimum chamfer  $r_{s\ min}$  of the shaft washer (WS) and the housing washer (GS).

**THRUST BEARINGS**

Tapered Roller thrust bearings are generally mounted with a fit range on the inside diameter of 127  $\mu\text{m}$  (0.0050 in.) loose to 400  $\mu\text{m}$  (0.0150 in.) loose. Sufficient clearance should be provided on the outside diameter to permit free centering of the bearing without interference.

When Type TTHD or TTHDFL thrust bearings are subjected to continuous rotation, the rotating race should be applied with a minimum interference fit of 25  $\mu\text{m}$  (0.0010 in.). Sufficient clearance should be provided on the outside diameter of the stationary race to permit free centering of the bearing without interference.

**MOUNTING DESIGNS - continued****TAPERED ROLLER BEARING MOUNTING PROCEDURE**

Bearing performances can be adversely affected by improper mounting procedure or lack of care during the assembly phase.

**Environment**

Cleanliness during the bearing mounting operation is essential for a rolling bearing to operate for maximum service life. Bearings in their shipping containers or wrapping have been coated for rust protection. While this coating is not sufficient to properly lubricate the bearing, it is compatible with most lubricants and therefore does not have to be removed when mounting the bearing in the majority of applications. Burrs, foreign matter and damaged bearing seats cause misalignment. Care should be taken to avoid shearing or damaging bearing seats during assembly which may introduce misalignment or result in a change of bearing setting during operation.

**Fitting**

Adequate tools must be provided to properly fit the inner and outer races on shafts or in housings to avoid damage. Direct shock on the races must be avoided. Often, bearing races have to be heated or cooled to ease assembly. Do not heat standard bearings above 150° C (300° F) or freeze outer races below -55° C (-65° F). For precision bearings, do not heat above 65° C (150° F) or freeze below -30° C (-20° F). Note: For more information on this subject, please contact your Timken representative.

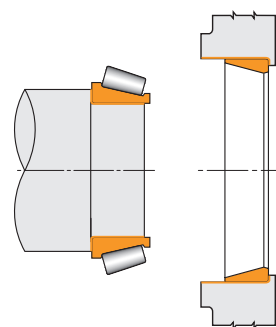

**Fig. A-17**  
Shaft and housing shoulders.

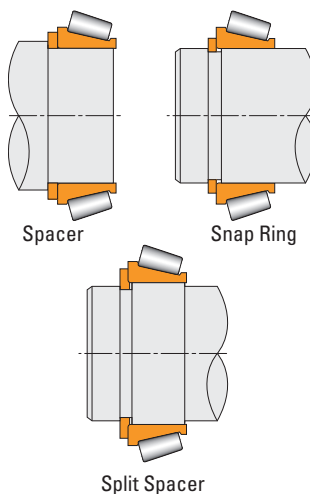

**Fig. A-18**  
Separate member used to provide adequate shaft shoulder diameter.

**MOUNTING DESIGNS**

The primary function of either the cone or cup backing shoulders is to positively establish the axial location and alignment of the bearing and its adjacent parts under all loading and operating conditions.

For a tapered roller bearing to operate for maximum service life, it is essential that a shoulder, square with the bearing axis and of sufficient diameter, is provided for each race. It must be of sufficient section and design to resist axial movement due to loading or distortion and must be wear-resistant at the interface with the bearing.

The conventional and most widely accepted method used to provide bearing backing is to machine a shoulder on a shaft or in the housing (Fig. A-17).

In some applications a spacer is used between a cone and shaft shoulder or a snap ring. As a further alternative, a split spacer can be used (Fig. A-18).

A spacer or snap ring can also be used for cup backing (Fig. A-19). If a snap ring is used for bearing backing it is suggested that an interference cup fit be used.

The cup used for bearing setting in a direct mounting (roller small ends pointing outwards) is usually set in position by a cup follower or by mounting in a carrier (Fig. A-20).

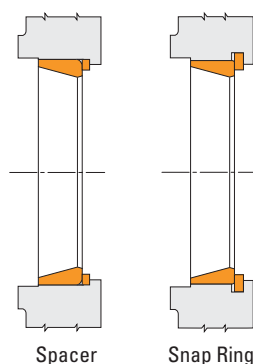

**Fig. A-19**  
Separate member used to provide adequate housing backing diameter.

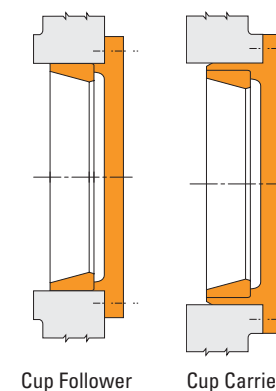

**Fig. A-20**  
Bearing setting devices  
- direct mounting.

**MOUNTING DESIGNS - continued**

With an indirect mounting (roller small ends pointing inwards), bearing setting can be achieved by a wide variety of devices (Fig. A-21).

In applications requiring precision class bearings, a special precision nut can be used. This has a soft metal shoe that is clamped against the threads with a locking screw. Other solutions can use split nut and/or ground spacers where setting cannot be altered (Fig. A-22).

**Snap rings**

In instances where snap rings are used to locate bearing components, it is important that they are of sufficient section to provide positive location. Care must be taken during installation or removal of the snap ring to prevent damage to the bearing cage.

**Removal**

Suitable means must be provided on adjacent bearing parts for easy bearing removal. Knockout slots, puller grooves and axial holes can be designed into the backing surfaces to ease removal of the cup or cone for servicing (Fig. A-23). In specific cases, hydraulic devices can also be used.

**Backing diameters**

Backing diameters, fillet clearances and cage clearances are listed for each individual part number in the bearing tables. Backing shoulder diameters shown should be considered as minimum values for shafts and maximum values for housings.

NOTE: Do not use a backing diameter that provides less backing surface than suggested.

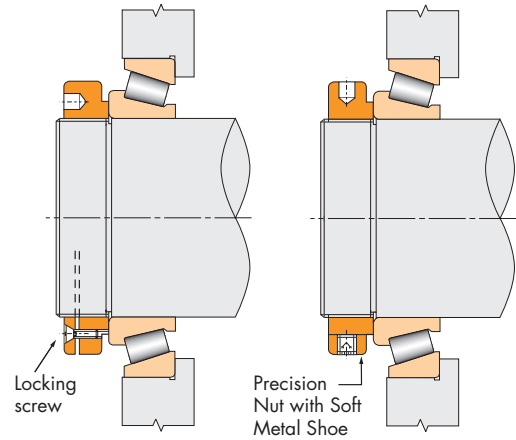

**Fig. A-22**  
Setting devices using split nut and precision nut with soft metal shoe.

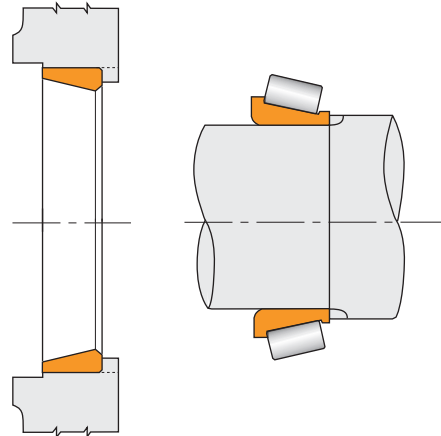

**Fig. A-23**  
Removal slots or puller grooves to ease removal.

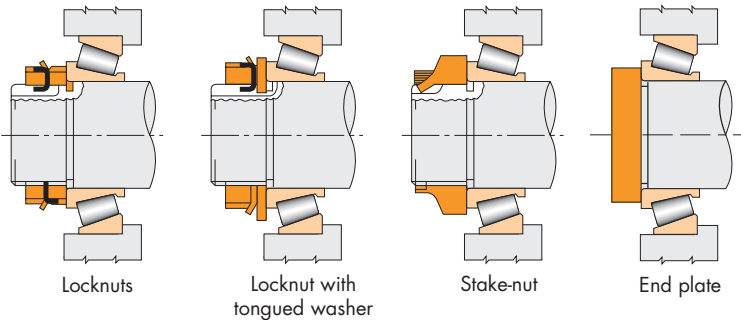

**Fig. A-21**  
Bearing setting devices - indirect mounting.



**MOUNTING DESIGNS - continued**

**SEATING**

**Geometry**

Two major causes of misalignment occur when the seats of cones and/or cups are machined out of square with the bearing axis or when the seats are parallel but out of alignment.

**Surface finishes – standard bearings**

For industrial applications, please refer to the following guidelines:

**GROUND SHAFTS**

All roller bearing shaft seats should be ground to a surface finish of 1.6 µm (65 µin)  $R_a$  maximum wherever possible. Ball bearing seats should be 0.8 µm (32 µin) for shafts under 2 inches and 1.6 µm (65 µin) for all other sizes.

**TURNED SHAFTS**

When shaft seats are turned, a tighter heavy-duty fit should be used. In this case the shaft diameter should be turned to a finish of 3.2 µm (125 µin)  $R_a$  maximum.

**HOUSING BORES**

Housing bores should be finished to 3.2 µm (125 µin)  $R_a$  maximum.

**Surface finishes - precision bearings**

Precision class bearings should be mounted on shafts and in housings that are finished to at least the same precision limits as the bearing bore or outside diameter.

Furthermore, high quality surface finishes together with close machining tolerances of bearing seats must also be provided. The following tabulations give some guidelines for all these criteria:

TAPERED ROLLER BEARINGS SURFACE FINISH – $R_a$ (µm - µin) BEARING CLASS				
ALL SIZES	C	B	A	AA
	3	0	00	000
Shaft	0.8 32	0.6 24	0.4 15	0.2 7
Housing	1.6 65	0.8 32	0.6 24	0.4 15

Correct fitting practice and precise bearing setting both affect bearing life, rigidity and, in the case of precision bearings, accuracy.

Improper fits will lead to problems such as poor machine performance including creeping of the cone on the spindle or the cup in the housing and lack of spindle stiffness.

The choice of fitting practices will mainly depend upon the following parameters:

- Precision class of the bearing.
- Rotating or stationary race.
- Type of layout (single/double-row bearings).
- Type and direction of load (continuous/alternate rotating).
- Particular running conditions like shocks, vibrations, overloading or high speed.
- Capability for machining the seats (grinding, turning or boring).
- Shaft and housing section and material.
- Mounting and setting conditions.
- Preadjusted tapered roller bearings must be mounted with the suggested fit.

**SHAFT AND HOUSING FITS**

Below is a graphical representation of shaft and housing fit selection for these bearings conforming to ANSI/ABMA Standard 7. The bars designated by g6, h6 etc., represent shaft/housing diameter and tolerance ranges to achieve various loose and interference fits required for various load and ring rotation conditions.

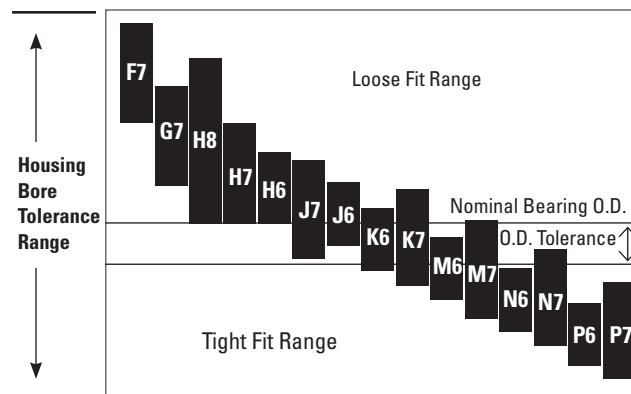
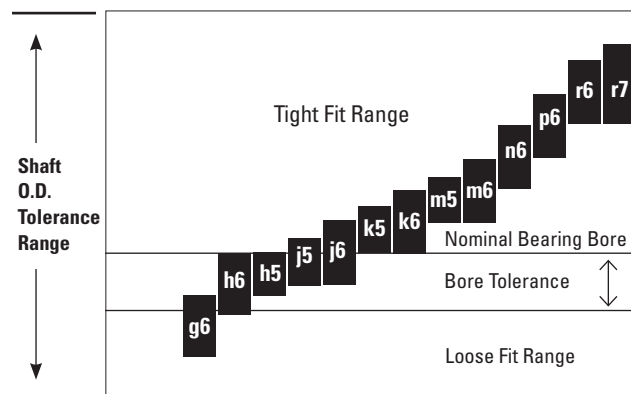



## FITTING PRACTICES

### TAPERED ROLLER BEARINGS

The design of a Timken tapered roller bearing allows the setting of bearing internal clearance during installation to optimize bearing operation.

General industrial application fitting practice standards for cones and cups are shown in the following tables. These tables apply to solid or heavy-sectioned steel shafts, heavy-sectioned ferrous housings and normal operating conditions. To use the tables, it is necessary to determine if the member is rotating or stationary, the magnitude, direction, and type of loading and the shaft finish.

Certain table fits may not be adequate for light shaft and housing sections, shafts other than steel, nonferrous housings, critical operation conditions such as high speed, unusual thermal or loading conditions or a combination thereof. Also assembly procedures and the means and ease of obtaining the bearing setting may require special fits. In these cases, experience should be used as a guideline or your Timken representative should be consulted for review and suggestions.

Rotating cones generally should be applied with an interference fit. In special cases loose fits may be considered if it has been determined by test or experience they will perform satisfactorily. The term "rotating cone" describes a condition in which the cone rotates relative to the load. This may occur with a rotating cone under a stationary load or a stationary cone with a rotating load. Loose fits will permit the cones to creep and wear the shaft and the backing shoulder. This will result in excessive bearing looseness and possible bearing and shaft damage.

Stationary cone fitting practice depends on the application. Under conditions of high speed, heavy loads or shock, interference fits using heavy-duty fitting practice should be used. With cones mounted on unground shafts subjected to moderate loads (no shock) and moderate speeds, a metal-to-metal or near zero average fit is used. In sheave and wheel applications using unground shafts, or in cases using ground shafts with moderate loads (no shock), a minimum fit near zero to a maximum looseness which varies with the cone bore size is suggested. In stationary cone applications requiring hardened and ground spindles, a slightly looser fit may be satisfactory. Special fits may also be necessary on installations such as multiple sheave crane blocks.

Rotating cup applications where the cup rotates relative to the load should always use an interference fit.

Stationary, nonadjustable and fixed single-row cup applications should be applied with a tight fit wherever practical. Generally, adjustable fits may be used where the bearing setup is obtained by sliding the cup axially in the housing bore. However, in certain heavy-duty, high-load applications, tight fits are necessary to prevent pounding and plastic deformation of the housing. Tightly fitted cups mounted in carriers can be used. Tight fits should always be used when the load rotates relative to the cup.

To permit through-boring when the outside diameters of single-row bearings mounted at each end of a shaft are equal and one is adjustable and the other fixed, it is suggested that the same adjustable fit be used at both ends. However, tight fits should be used if cups are backed against snap rings, to prevent excessive dishing of snap rings, groove wear and possible loss of ring retention. Only cups with a maximum housing fillet radius requirement of 1.3 mm (0.05 in.) or less should be considered for a snap ring backing.

Two-row stationary double cups are generally mounted with loose fits to permit assembly and disassembly. The loose fit also permits float when a floating bearing is mounted in conjunction with an axially fixed bearing on the other end of the shaft.

The fitting practice tables that follow have been prepared for both metric and inch dimensions.

For the inch system bearings, classes 4 and 2 (standard) and classes 3, 0, and 00 (precision) have been included.

The metric system bearings that have been included are: Classes K and N (metric system standard bearings) and classes C, B, and A (metric system precision bearings).

Precision class bearings should be mounted on shafts and in housings which are similarly finished to at least the same precision limits as the bearing bore and O.D. High quality surface finishes should also be provided.

Two-row and four-row bearings, which are provided with spacers and shipped as matched assemblies, have been preset to a specific bench endplay. The specific endplay setting is determined from a study of the bearing mounting and expected environment. It is dependent on the fitting practice and the required mounted bearing settings.



FITTING PRACTICES - continued

For rolling mill neck fitting practice, consult your Timken representative. For all other equipment associated with the rolling mill industry, the fitting practice suggestions in the tables that follow should be used.

In addition to all other axial tolerances and the overall bearing width tolerance, the width increase due to tight fits of the cone or cup, or both, must be considered when axial tolerance summation calculations are made. By knowing the fit range, the minimum and maximum bearing width increase can be determined to establish the initial design dimensions. For instance, all tolerances plus the bearing width increase range due to tight fits must be known in order to calculate the shim gap range that would occur on a cup adjusted, direct mounting design.

In a factory preset bearing or a SET-RIGHT™ mounting, where the bearing overall width is fixed and clamped, tight fits will cause cup expansion or cone contraction which will reduce the internal clearance (endplay) within the bearing.

**Endplay Removed for Single Cone**

$$= 0.5 \left( \frac{K}{0.39} \right) \left( \frac{d}{d_o} \right) \delta_S$$

The following equations under Normal Sections and Thin Wall Sections can be used to calculate endplay removed in a similar manner.

where:

- K = Tapered Roller Bearing Radial-to-Axial Dynamic Load Rating Factor
- d = Bearing Bore Diameter
- d<sub>o</sub> = Mean Inner Race Diameter
- D<sub>o</sub> = Mean Outer Race Diameter
- d<sub>s</sub> = Shaft Inside Diameter
- D = Bearing Outside Diameter
- D<sub>H</sub> = Housing Outside Diameter
- δ<sub>S</sub> = Interference Fit of Inner Race on Shaft
- δ<sub>H</sub> = Interference Fit of Outer Race in Housing

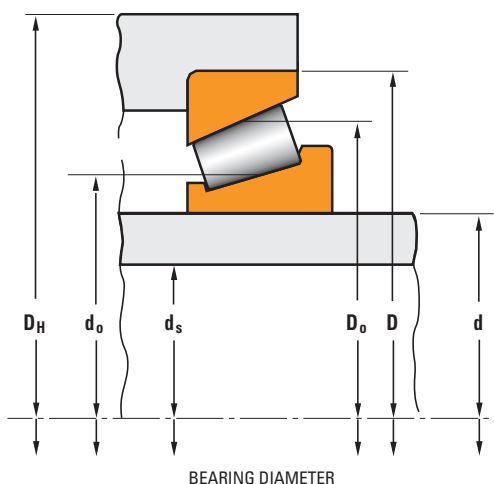

**EFFECT OF TIGHT FITS ON BEARING WIDTH**

**Normal Sections**

The interference fit of either the cone or the cup increases the overall bearing width. For solid steel shafts and heavy sectioned steel housings, the increased bearing width for a single-row bearing is as follows. (Refer to diagram to the left.)

**Bearing Width Increase for Single Cone**

$$= 0.5 \left( \frac{K}{0.39} \right) \left( \frac{d}{d_o} \right) \delta_S$$

**Bearing Width Increase for Single Cup**

$$= 0.5 \left( \frac{K}{0.39} \right) \left( \frac{D_o}{D} \right) \delta_H$$

If the shaft or housing material is other than steel, consult your Timken representative.

**Thin Wall Sections**

Interference fits on thin-walled steel shafts and light-sectioned steel housings have a tendency to collapse the cone seat and stretch the cup seat, causing less change in bearing width than when used with solid shafts and heavy housings. The bearing width change due to tight fits on thin bearing seat sections is as follows. (Refer to diagram to the left.)

**Bearing Width Increase for Single Cone**

$$= 0.5 \left( \frac{K}{0.39} \right) \left\{ \frac{\left( \frac{d}{d_o} \right) \left[ 1 - \left( \frac{d_s}{d} \right)^2 \right]}{1 - \left( \frac{d_s}{d_o} \right)^2} \right\} \delta_S$$

**Bearing Width Increase for Single Cup**

$$= 0.5 \left( \frac{K}{0.39} \right) \left\{ \frac{\left( \frac{D_o}{D} \right) \left[ 1 - \left( \frac{D}{D_H} \right)^2 \right]}{1 - \left( \frac{D_o}{D_H} \right)^2} \right\} \delta_H$$

These equations apply only to steel shafts and housings.

FITTING PRACTICES - continued

FITTING GUIDELINES FOR METRIC BEARINGS (ISO AND J PREFIX)  
INDUSTRIAL EQUIPMENT BEARING CLASSES K AND N

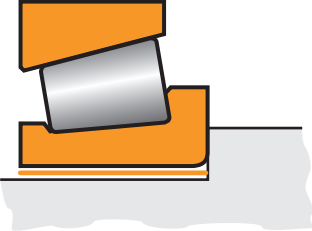
SHAFT O.D. (µm)	BEARING BORE		ROTATING SHAFT			ROTATING OR STATIONARY SHAFT			
	Range mm	Tolerance µm	Ground Constant loads with moderate shock			Unground or Ground Heavy Loads or High Speed or Shock			
Deviation from nominal (maximum bearing bore and resultant fit (µm))	over	incl.	Symbol	Shaft O.D. Deviation	Resultant Fit	Symbol	Shaft O.D. Deviation	Resultant Fit	
T = Tight L = Loose	10	18	-12 0	m6	+18 +7	30T 7T	n6	+23 +12	35T 12T
	18	30	-12 0	m6	+21 +8	33T 8T	n6	+28 +15	40T 15T
	30	50	-12 0	m6	+25 +9	37T 9T	n6	+33 +17	45T 17T
	50	80	-15 0	m6	+30 +11	45T 11T	n6	+39 +20	54T 20T
	80	120	-20 0	m6	+35 +13	55T 13T	n6	+45 +23	65T 23T
	120	180	-25 0	m6	+40 +15	65T 15T	p6	+68 +43	93T 43T
	180	200						+106 +77	136T 77T
	200	225	-30 0	m6	+46 +17	76T 17T	r6	+109 +80	139T 80T
	225	250						+113 +84	143T 84T
	250	280	-35 0	m6	+52 +20	87T 20T	r6	+126 +94	161T 94T
	280	315						+130 +98	165T 98T
	315	355	-40 0	n6	+73 +37	113T 37T	r6	+144 +108	184T 108T
	355	400						+150 +114	190T 114T
	400	450	-45 0	n6	+80 +40	125T 40T	r6	+166 +126	211T 126T
	450	500						+172 +132	217T 132T
	500	560	-50 0	n6	+88 +44	138T 44T	r6	+194 +150	244T 150T
	560	630						+199 +155	249T 155T
	630	710	-80 0	n7	+130 +50	210T 50T	r7	+255 +175	335T 175T
	710	800						+265 +185	345T 185T
	800	900	-100 0	n7	+146 +56	246T 56T	r7	+300 +210	400T 210T
	900	1000						+310 +220	410T 220T



STATIONARY SHAFT											
Unground Moderate Loads, No Shock			Ground Moderate Loads, No Shock			Unground Sheaves, Wheels, Idlers			Hardened and Ground Wheel Spindles		
Symbol	Shaft O.D. Deviation	Resultant Fit	Symbol	Shaft O.D. Deviation	Resultant Fit	Symbol	Shaft O.D. Deviation	Resultant Fit	Symbol	Shaft O.D. Deviation	Resultant Fit
h6	0 -11	12T 11L	g6	-6 -17	6T 17L	g6	-6 -17	6T 17L	f6	-16 -27	4L 27L
h6	0 -13	12T 13L	g6	-7 -20	5T 20L	g6	-7 -20	5T 20L	f6	-20 -33	8L 33L
h6	0 -16	12T 16L	g6	-9 -25	3T 25L	g6	-9 -25	3T 25L	f6	-25 -41	13L 41L
h6	0 -19	15T 19L	g6	-10 -29	5T 29L	g6	-10 -29	5T 29L	f6	-30 -49	15L 49L
h6	0 -22	20T 22L	g6	-12 -34	8T 34L	g6	-12 -34	8T 34L	f6	-36 -58	16L 58L
h6	0 -25	25T 25L	g6	-14 -39	11T 39L	g6	-14 -39	11T 39L	f6	-43 -68	18L 68L
h6	0 -29	30T 29L	g6	-15 -44	15T 44L	g6	-15 -44	15T 44L	f6	-50 -79	20L 79L
h6	0 -32	35T 32L	g6	-17 -49	18T 49L	g6	-17 -49	18T 49L	f6	-56 -88	21L 88L
h6	0 -36	40T 36L	g6	-18 -54	22T 54L	g6	-18 -54	22T 54L	-	-	-
h6	0 -40	45T 40L	g6	-20 -60	25T 60L	g6	-20 -60	25T 60L	-	-	-
h6	0 -44	50T 44L	g6	-22 -66	28T 66L	g6	-22 -66	28T 66L	-	-	-
h7	0 -80	80T 80L	g7	-24 -104	56T 104L	g7	-24 -104	56T 104L	-	-	-
h7	0 -90	100T 90L	g7	-26 -116	74T 116L	g7	-26 -116	74T 116L	-	-	-

FITTING PRACTICES - continued

FITTING GUIDELINES FOR METRIC BEARINGS (ISO AND J PREFIX)  
INDUSTRIAL EQUIPMENT BEARING CLASSES K AND N

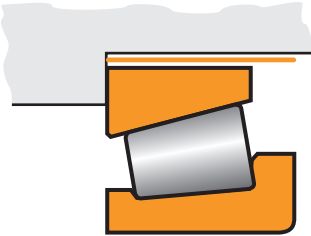
HOUSING BORE(μm)	BEARING O.D.		STATIONARY HOUSING		
	Range mm	Tolerance μm	Floating or Clamped Race		
Deviation from nominal (maximum) bearing bore and resultant fit (μm)	over	incl.	Symbol	Housing Bore Deviation	Resultant fit
T= Tight L = Loose	18	30	G7	+7	7L
				-12	+28
	30	50	G7	+9	9L
				-14	+34
	50	65	G7	+10	10L
				-16	+40
	65	80	G7	+12	12L
				-18	+47
	80	100	G7	+14	14L
				-20	+54
	100	120	G7	+14	14L
				-25	+54
	120	140	G7	+15	15L
				-30	+61
	140	150	G7	+17	17L
				-35	+69
	150	160	F7	+62	62L
				-40	+119
	160	180	F7	+68	68L
				-45	+131
	180	200	F7	+76	76L
				-50	+146
	200	225	F7	+80	80L
				-80	+160
	225	250	F7	+86	86L
				-100	+176
	250	280	F7		
	280	315	F7		
	315	355	F7		
	355	400	F7		
	400	450	F7		
	450	500	F7		
	500	560	F7		
	560	630	F7		
	630	710	F7		
	710	800	F7		
	800	900	F7		
	900	1000	F7		



STATIONARY HOUSING						ROTATING HOUSING		
Adjustable Race			Non-adjustable Race or in Carrier			Non-adjustable Race or in Carrier or Sheave - Clamped Race		
Symbol	Housing Bore Deviation	Resultant Fit	Symbol	Housing Bore Deviation	Resultant Fit	Symbol	Housing Bore Deviation	Resultant Fit
J7	-9 +12	9T 24L	P7	-35 -14	35T 2T	R7	-41 -20	41T 8T
J7	-11 +14	11T 28L	P7	-42 -17	42T 3T	R7	-50 -25	50T 11T
J7	-12 +18	12T 34L	P7	-51 -21	51T 5T	R7	-60 -30 -62 -32	60T 14T 62T 16T
J7	-13 +22	13T 40L	P7	-59 -24	59T 6T	R7	-73 -38 -76 -41	73T 20T 76T 23T
J7	-14 +26	14T 46L	P7	-68 -28	68T 8T	R7	-88 -48 -90 -50	88T 28T 90T 30T
J7	-14 +26	14T 51L	P7	-68 -28	68T 3T	R7	-90 -50 -93 -53	90T 25T 93T 28T
J7	-16 +30	16T 60L	P7	-79 -33	79T 3T	R7	-106 -60 -109 -63 -113 -67	106T 30T 109T 33T 113T 37T
J7	-16 +36	16T 71L	P7	-88 -36	88T 1T	R7	-126 -74 -130 -78	126T 39T 130T 43T
J7	-18 +39	18T 79L	P7	-98 -41	98T 1T	R7	-144 -87 -150 -93	144T 47T 150T 53T
J7	-20 +43	20T 88L	P7	-108 -45	108T 0	R7	-166 -103 -172 -109	166T 58T 172T 64T
JS7	-35 +35	35T 85L	P7	-148 -78	148T 28T	R7	-220 -150 -225 -155	220T 100T 225T 105T
JS7	-40 +40	40T 120L	P7	-168 -88	168T 8T	R7	-255 -175 -245 -185	255T 95T 265T 105T
JS7	-45 +45	45T 145L	P7	-190 -100	190T 0	R7	-300 -210 -310 -220	300T 110T 310T 120T

FITTING PRACTICES - *continued*

**FITTING GUIDELINES FOR INCH BEARINGS  
INDUSTRIAL EQUIPMENT BEARING CLASSES 4 AND 2**

SHAFT O.D. (µm - INCHES)	BEARING BORE		ROTATING SHAFT		
	Range mm (inches)		Tolerance µm (0.0001 in.)	Ground Constant loads with moderate shock	
Deviation from nominal (minimum) bearing bore and resultant fit (µm - 0.0001 inch)	over	incl.		Shaft O.D. Deviation	Resultant Fit
T= Tight L = Loose	0	76.2	0	+38	38T
	0	3.0000	+13	+25	12T
			0	+15	15T
			+5	+10	5T
	76.2	88.9			
	3.0000	3.5000			
	88.9	114.3			
	3.5000	4.5000			
	114.3	139.7			
	4.5000	5.5000			
139.7	165.1				
5.5000	6.5000				
165.1	190.5	0	+64	64T	
6.5000	7.5000	+25	+38	13T	
		0	+25	25T	
		+10	+15	5T	
190.5	215.9				
7.5000	8.5000				
215.9	241.3				
8.5000	9.5000				
241.3	266.7				
9.5000	10.5000				
266.7	292.1				
10.5000	11.5000				
292.1	304.8				
11.5000	12.0000				
304.8	317.5				
12.0000	12.5000	0	+127	127T	
		+51	+76	25T	
317.5	342.9	0	+50	50T	
12.5000	13.5000	+20	+30	10T	

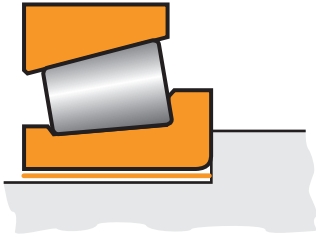

\* Suggested heavy-duty fitting practices shown above are applicable for case carburized bearings. Consult your Timken representative for the suggested heavy-duty fitting practices that are specified for through hardened bearings.



ROTATING OR STATIONARY SHAFT		STATIONARY SHAFT							
Unground or Ground Heavy Loads, High Speed or Shock*		Unground Moderate Loads, No Shock		Ground Moderate Loads, No Shock		Unground Sheaves, Wheels, Idlers		Hardened and Ground Wheel Spindles	
Shaft O.D. Deviation	Resultant Fit	Shaft O.D. Deviation	Resultant Fit	Shaft O.D. Deviation	Resultant Fit	Shaft O.D. Deviation	Resultant Fit	Shaft O.D. Deviation	Resultant Fit
+64	64T	+13	13T	0	0	0	0	-5	5L
+38	25T	0	13L	-13	26L	-13	26L	-18	31L
+25	25T	+5	5T	0	0	0	0	-2	2L
+15	10T	0	5L	-5	10L	-5	10L	-7	12L
+76	76T								
+51	25T								
+30	30T								
+20	10T								
+76	76T								
+51	25T								
+30	30T								
+20	10T								
+89	89T								
+64	38T								
+35	35T								
+25	15T								
+102	102T								
+76	51T								
+40	40T								
+30	20T								
+114	114T	+25	25T	0	0	0	0	-5	5L
+89	64T	0	25L	-25	50L	-25	50L	-30	55L
+45	45T	+10	10T	0	0	0	0	-2	2L
+35	25T	0	10L	-10	20L	-10	20L	-12	22L
+127	127T								
+102	76T								
+50	50T								
+40	30T								
+140	140T								
+114	89T								
+55	55T								
+45	35T								
+152	152T								
+127	102T								
+60	60T								
+50	40T								
+165	165T								
+140	114T								
+65	65T								
+55	45T								
+178	178T								
+152	127T								
+70	70T								
+60	50T								
+203	203T								
+152	101T								
+80	80T	+51	51T	0	0	0	0	-	-
+60	40T	0	51L	-51	102L	-51	102L	-	-
+216	216T	+20	20T	0	0	0	0	-	-
+165	114T	0	20L	-20	40L	-20	40L	-	-
+85	85T								
+65	45T								

FITTING PRACTICES - continued

FITTING GUIDELINES FOR INCH BEARINGS  
INDUSTRIAL EQUIPMENT BEARING CLASSES 4 AND 2

SHAFT O.D. (µm - INCHES)	BEARING BORE		ROTATING SHAFT		
	Range mm (inches)		Tolerance µm (0.0001 in.)	Ground Constant loads with moderate shock	
	over	incl.		Shaft O.D. Deviation	Resultant Fit
	342.9	368.3			
	13.5000	14.5000			
	368.3	393.7			
	14.5000	15.5000			
	393.7	419.1			
	15.5000	16.5000			
	419.1	444.5			
	16.5000	17.5000			
	444.5	469.9			
	17.5000	18.5000			
	469.9	495.3	0	+127	127T
	18.5000	19.5000	+51	+76	25T
			0	+50	50T
			+20	+30	10T
	495.3	520.7			
	19.5000	20.5000			
	520.7	546.1			
	20.5000	21.5000			
	546.1	571.5			
	21.5000	22.5000			
	571.5	596.9			
	22.5000	23.5000			
	596.9	609.6			
	23.5000	24.0000			
	609.6	914.4	0	+190	190T
	24.0000	36.0000	+76	+114	38T
			0	+75	75T
			+30	+45	15T
	914.4	1219.2	0	+252	252T
	36.0000	48.0000	+102	+150	48T
			0	+100	100T
			+40	+60	20T
	1219.2	—	0	+305	305T
	48.0000	—	+127	+178	51T
			0	+120	120T
			+50	+70	20T

Deviation from nominal (minimum) bearing bore and resultant fit (µm - 0.0001 inch)

T= Tight  
L= Loose

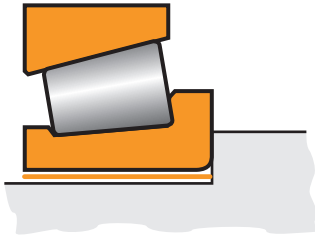

\* Suggested heavy-duty fitting practices shown above are applicable for case carburized bearings. Consult your Timken representative for the suggested heavy-duty fitting practices that are specified for through hardened bearings.



ROTATION OR STATIONARY SHAFT		STATIONARY SHAFT							
Unground or Ground Heavy Loads, High Speed or Shock*		Unground Moderate Loads, No Shock		Ground Moderate Loads, No Shock		Unground Sheaves, Wheels, Idlers		Hardened and Ground Wheel Spindles	
Shaft O.D. Deviation	Resultant Fit	Shaft O.D. Deviation	Resultant Fit	Shaft O.D. Deviation	Resultant Fit	Shaft O.D. Deviation	Resultant Fit	Shaft O.D. Deviation	Resultant Fit
+229	229T								
+178	127T								
+90	90T								
+70	50T								
+241	241T								
+190	139T								
+95	95T								
+75	55T								
+254	254T								
+203	152T								
+100	100T								
+80	60T								
+267	267T								
+216	165T								
+105	105T								
+85	65T								
+279	279T								
+229	178T								
+110	110T								
+90	70T								
+292	292T	+51	51T	0	0	0	0	-	-
+241	190T	0	51L	-51	102L	-51	102L	-	-
+115	115T	+20	20T	0	0	0	0	-	-
+95	75T	0	20L	-20	40L	-20	40L	-	-
+305	305T								
+254	203T								
+120	120T								
+100	80T								
+318	318T								
+267	216T								
+125	125T								
+105	85T								
+330	330T								
+279	228T								
+130	130T								
+110	90T								
+343	343T								
+292	241T								
+135	135T								
+115	95T								
+356	356T								
+305	254T								
+140	140T								
+120	100T								
+457	457T	+76	76T	0	0	0	0	-	-
+331	305T	0	76L	-76	152L	-76	152L	-	-
+180	180T	+30	30T	0	0	0	0	-	-
+150	120T	0	30L	-30	60L	-30	60L	-	-
+625	625T	+102	102T	0	0	0	0	-	-
+534	432T	0	102L	-102	204L	-102	204L	-	-
+250	250T	+40	40T	0	0	0	0	-	-
+210	170T	0	40L	-40	80L	-40	80L	-	-
+813	813T	+127	127T	0	0	0	0	-	-
+686	559T	0	127L	-127	254L	-127	254L	-	-
+320	320T	+50	50T	0	0	0	0	-	-
+270	220T	0	50L	-50	100L	-50	100L	-	-

FITTING PRACTICES - continued

FITTING GUIDELINES FOR INCH BEARINGS  
INDUSTRIAL EQUIPMENT BEARING CLASSES 4 AND 2

**HOUSING BORE (µm)**

Deviation from nominal (minimum) bearing bore and resultant fit (µm)

T= Tight  
L = Loose

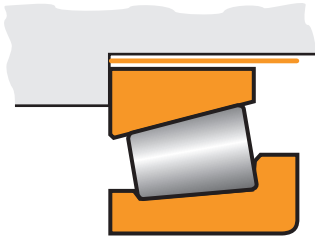

HOUSING BORE (µm)		BEARING O.D.		STATIONARY HOUSING	
Range mm		Tolerance µm		Floating or Clamped Race	
over	incl.			Housing Bore Deviation	Resultant Fit
0	76.2	+25	0	+51	26L
				+76	76L
76.2	127	+25	0	+51	26L
				+76	76L
127	304.8	+25	0	+51	26L
				+76	76L
304.8	609.6	+51	0	+102	51L
				+152	152L
609.6	914.4	+76	0	+152	76L
				+229	229L
914.4	1219.2	+102	0	+204	102L
				+305	305L
1219.2	—	+127	0	+254	127L
				+381	381L

\* Unclamped race design is applicable only to sheaves with negligible fleet angle.

**HOUSING BORE (INCHES)**

Deviation from nominal (minimum) bearing bore and resultant fit (0.0001 inch)

T= Tight  
L = Loose

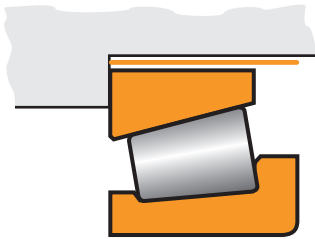

HOUSING BORE (INCHES)		BEARING O.D.		STATIONARY HOUSING	
Range inches		Tolerance 0.0001 in.		Floating or Clamped Race	
over	incl.			Housing Bore Deviation	Resultant Fit
0	3.0000	+10	0	+20	10L
				+30	30L
3.0000	5.0000	+10	0	+20	10L
				+30	30L
5.0000	12.0000	+10	0	+20	10L
				+30	30L
12.0000	24.0000	+20	0	+40	20L
				+60	60L
24.0000	36.0000	+30	0	+60	30L
				+90	90L
36.0000	48.0000	+40	0	+80	40L
				+120	120L
48.0000	—	+50	0	+100	50L
				+150	150L

\* Unclamped race design is applicable only to sheaves with negligible fleet angle.

STATIONARY HOUSING		STATIONARY OR ROTATION HOUSING		ROTATING HOUSING	
Adjustable Race		Non-adjustable Race or In Carrier or Sheave - Clamped Race		Sheave-unclamped Race*	
Housing bore Deviation	Resultant Fit	Housing Bore Deviation	Resultant Fit	Housing Bore Deviation	Resultant Fit
0	25T	-38	63T	-76	101T
+25	25L	-13	13T	-51	51T
0	25T	-51	76T	-76	101T
+25	25L	-25	25T	-51	51T
0	25T	-51	76T	-76	101T
+51	51L	-25	25T	-51	51T
+26	25T	-76	127T	-102	153T
+76	76L	-25	25T	-51	51T
+51	25T	-102	178T	–	–
+127	127L	-25	25T	–	–
+76	25T	-127	229T	–	–
+178	178L	-25	25T	–	–
+102	25T	-152	279T	–	–
+229	229L	-25	25T	–	–

STATIONARY HOUSING		STATIONARY OR ROTATION HOUSING		ROTATING HOUSING	
Adjustable Race		Non-adjustable Race or In Carrier or Sheave - Clamped Race		Sheave-unclamped Race*	
Housing bore Deviation	Resultant Fit	Housing Bore Deviation	Resultant Fit	Housing Bore Deviation	Resultant Fit
0	10T	-15	25T	-30	40T
+10	10L	-5	5T	-20	20T
0	10T	-20	30T	-30	40T
+10	10L	-10	10T	-20	20T
0	10T	-20	30T	-30	40T
+20	20L	-10	10T	-20	20T
+10	10T	-30	50T	-40	60T
+30	30L	-10	10T	-20	20T
+20	10T	-40	70T	–	–
+50	50L	-10	10T	–	–
+30	10T	-50	90T	–	–
+70	70L	-10	10T	–	–
+40	10T	-60	110T	–	–
+90	90L	-10	10T	–	–

FITTING PRACTICES - continued

FITTING GUIDELINES FOR PRECISION BEARINGS

SHAFT O.D. METRIC BEARINGS (ISO & J Prefix)

Deviation from nominal (maximum) bearing bore and resultant fit (µm)

T= Tight  
L = Loose

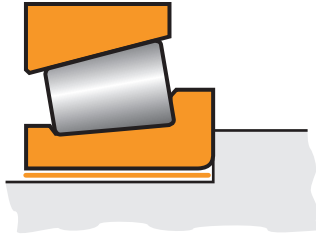

BEARING BORE		CLASS C			
Range		Bearing Bore Tolerance µm	Symbol	Shaft O.D. Deviation	Resultant Fit
over	incl.				
10	18	-7 0	k5	+9 +1	16T 1T
18	30	-8 0	k5	+11 +2	19T 2T
30	50	-10 0	k5	+13 +2	23T 2T
50	80	-12 0	k5	+15 +2	27T 2T
80	120	-15 0	k5	+18 +3	33T 3T
120	180	-18 0	k5	+21 +3	39T 3T
180	250	-22 0	k5	+24 +4	46T 4T
250	315	-22 0	k5	+27 +4	49T 4T

SHAFT O.D. INCH BEARINGS

Deviation from nominal (minimum) bearing bore and resultant fit (µm - 0.0001 inch)

T= Tight  
L = Loose

BEARING BORE		CLASS 3 AND 0 <sup>(1)</sup>			CLASS 00 AND 000		
Range mm (inches)		Bearing Bore Tolerance µm (0.0001 in.)	Shaft O.D. Deviation	Resultant Fit	Bearing Bore Tolerance	Shaft O.D. Deviation	Resultant Fit
over	incl.						
-	304.8	0	+30	30T	0	+20	20T
		+13	+18	5T	+8	+13	5T
		0	+12	12T	0	+8	8T
		+5	+7	2T	+3	+5	2T
304.8	609.6	0	+64	64T	-	-	-
		+25	+38	13T	-	-	-
		0	+25	25T	-	-	-
		+10	+15	5T	-	-	-
609.6	914.4	0	+102	102T	-	-	-
		+38	+64	26T	-	-	-
		0	+40	40T	-	-	-
		+15	+25	10T	-	-	-

<sup>(1)</sup>Class 0 made only to 304.8 mm (12 inch) O.D.

FITTING PRACTICES - *continued*

CLASS B				BEARING BORE		CLASS A AND AA			
Bearing Bore Tolerance	Symbol	Shaft O.D. Deviation	Resultant Fit	Range mm		Bearing Bore Tolerance	Symbol	Shaft O.D. Deviation	Resultant Fit
				over	incl.				
-5 0	k5	+9 +1	14T 1T	10	18	-5 0	k4	+6 +1	11T 1T
-6 0	k5	+11 +2	17T 2T	18	30	-6 0	k4	+8 +2	14T 2T
-8 0	k5	+13 +2	21T 2T	30	315	-8 0		+13 +5	21T 5T
-9 0	k5	+15 +2	24T 2T						
-10 0	k5	+18 +3	28T 3T						
-13 0	k5	+21 +3	34T 3T						
-15 0	k5	+24 +4	39T 4T						
-15 0	k5	+27 +4	42T 4T						

FITTING PRACTICES - continued

FITTING GUIDELINES FOR PRECISION BEARINGS

**HOUSING BORE METRIC BEARINGS**

Deviation from nominal (maximum) bearing O.D. and resultant fit (µm)

T= Tight  
L = Loose

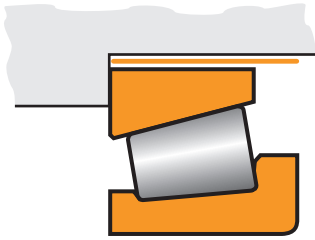

BEARING O.D.		CLASS C								
Range mm	Tolerance µm	Non-adjustable or In Carrier			Floating			Adjustable		
		Symbol	Housing Bore Deviation	Resultant Fit	Symbol	Housing Bore Deviation	Resultant Fit	Symbol	Housing Bore Deviation	Resultant Fit
18 over 30	0 -8	N5	-21 -12	21T 4T	G5	+7 +16	7L 24L	K5	-8 +1	8T 9L
30 over 50	0 -9	N5	-24 -13	24T 4T	G5	+9 +20	9L 29L	K5	-9 +2	9T 11L
50 over 80	0 -11	N5	-28 -15	28T 4T	G5	+10 +23	10L 34L	K5	-10 +3	10T 14L
80 over 120	0 -13	N5	-33 -18	33T 5T	G5	+12 +27	12L 40L	K5	-13 +2	13T 15L
120 over 150	0 -15	N5	-39 -21	39T 6T	G5	+14 +32	14L 47L	K5	-15 +3	15T 18L
150 over 180	0 -18	N5	-39 -21	39T 3T	G5	+14 +32	14L 50L	K5	-15 +3	15T 21L
180 over 250	0 -20	N5	-45 -25	45T 5T	G5	+15 +35	15L 55L	K5	-18 +2	18T 27L
250 over 315	0 -25	N5	-50 -27	50T 2T	G5	+17 +40	17L 65L	K5	-20 +3	20T 28L

**HOUSING BORE INCH BEARINGS**

Deviation from nominal (minimum) bearing O.D. and resultant fit (µm - 0.0001 inch)

T= Tight  
L = Loose

BEARING O.D.		CLASS 3 AND 0 <sup>1</sup>						
Range mm (inches)	Tolerance µm (0.0001 in.)	Non-adjustable or In Carrier			Floating		Adjustable	
		Housing Bore Deviation	Resultant Fit	Housing Bore Deviation	Resultant Fit	Housing Bore Deviation	Resultant Fit	
— over 152.4	+13 0 0	-13	26T	+25	12L	0	13T	
		0	0	+38	38L	+13	13L	
		0	0	+10 +15	5L 15L	0 +5	5T 5L	
152.4 over 304.8	+13 0 0	-25	38T	+25	12L	0	13T	
		0	0	+38	38L	+25	25L	
		0	0	+10 +15	5L 15L	0 +10	5T 10L	
304.8 over 609.6	+25 0 0	-25	50T	+38	13L	0	25T	
		0	0	+64	64L	+25	25L	
		0	0	+15 +25	5L 25L	0 +10	10T 10L	
609.6 over 914.4	+38 0 0	-38	76T	+51	13L	0	38T	
		0	0	+89	89L	+38	38L	
		0	0	+20 +35	5L 35L	0 +15	15T 15L	

<sup>(1)</sup>Class 0 made only to 304.8 mm (12 inch) O.D.



BEARING O.D.			CLASS B								
Range mm (inches)	Tolerance µm	Non-adjustable or In Carrier			Floating			Adjustable			
		Symbol	Housing Bore Deviation	Resultant Fit	Symbol	Housing Bore Deviation	Resultant Fit	Symbol	Housing Bore Deviation	Resultant Fit	
over	incl.										
18	30	0 -6	M5	-14 -5	14T 1L	G5	+7 +16	7L 22L	K5	-8 +1	8T 7L
30	50	0 -7	M5	-16 -5	16T 2L	G5	+9 +20	9L 27L	K5	-9 +2	9T 9L
50	80	0 -9	M5	-19 -6	19T 3L	G5	+10 +23	10L 32L	K5	-10 +3	10T 12L
80	120	0 -10	M5	-23 -8	23T 2L	G5	+12 +27	12L 37L	K5	-13 +2	13T 12L
120	150	0 -11	M5	-27 -9	27T 2L	G5	+14 +32	14L 43L	K5	-15 +3	15T 12L
150	180	0 -13	M5	-27 -9	27T 4L	G5	+14 +32	14L 45L	K5	-15 +3	15T 16L
180	250	0 -15	M5	-31 -11	31T 4L	G5	+15 +35	15L 50L	K5	-18 +2	18T 17L
250	315	0 -18	M5	-36 -13	36T 5L	G5	+17 +40	17L 58L	K5	-20 +3	20T 21L

BEARING O.D.			CLASS A AND AA					
Range mm	Tolerance µm (0.0001 in.)	Non-adjustable or In Carrier		Floating		Adjustable		
		Housing Bore Deviation	Resultant Fit	Housing Bore Deviation	Resultant Fit	Housing Bore Deviation	Resultant Fit	
over	incl.							
0	315	-0 -8	-16 -8	16T 0	+8 +16	8L 24L	-8 -0	8T 8L

BEARING O.D.			CLASS 00 AND 000					
Range mm (inches)	Tolerance µm (0.0001 in.)	Non-adjustable or In Carrier		Floating		Adjustable		
		Housing Bore Deviation	Resultant Fit	Housing Bore Deviation	Resultant Fit	Housing Bore Deviation	Resultant Fit	
over	incl.							
0	304.8	+8 0	-8 0	16T 0	+15 +23	7L 23L	0 +8	8T 8L
0	12	+3 0	-3 0	6T 0	+6 +9	3L 9L	0 +3	3T 3L

FITTING PRACTICES - continued

**FITTING GUIDELINES FOR INCH BEARINGS  
AUTOMOTIVE EQUIPMENT  
BEARING CLASSES 4 AND 2**

**SHAFT O.D. (µm - INCHES)**

Deviation from nominal (minimum) bearing bore and resultant fit (µm - 0.0001 inch)

T= Tight  
L= Loose

CONE BORE			STATIONARY CONE	
over	incl.	Tolerance	Resultant	
mm	mm	µm	Deviation	Fit
0	76.200	0 +13	-5 -18	5L 31L
76.200	304.800	0 +25	-13 -38	13L 63L
in.	in.	in.	in.	in.
0	3.0000	0 +.0005	-.0002 -.0007	.0002L .0012L
3.0000	12.0000	0 +.0010	-.0005 -.0015	.0005L .0025L

Heavy-duty min. fit of .0005 inch per inch of cone bore

**FITTING GUIDELINES FOR METRIC BEARINGS  
AUTOMOTIVE EQUIPMENT  
BEARING CLASSES K AND N**

**SHAFT O.D. (µm - INCHES)**

Deviation from nominal (maximum) bearing bore and resultant fit (µm - 0.0001 inch)

T= Tight  
L= Loose

CONE BORE			STATIONARY CONE	
over	incl.	Tolerance	Resultant	
mm	mm	µm	Deviation	Fit
18	30	-12 0	f6 -20 -33	8L 33L
30	50	-12 0	f6 -25 -41	13L 41L
50	80	-15 0	f6 -30 -49	15L 49L
80	120	-20 0	f6 -36 -58	16L 58L
120	180	-25 0	f6 -43 -68	18L 68L
in.	in.	in.	in.	in.
.7087	1.1811	-.0005 0	f6 -.0008 -.0013	.0003L .0013L
1.1811	1.9865	-.0005 0	f6 -.0010 -.0016	.0005L .0016L
1.9685	3.1496	-.0006 0	f6 -.0012 -.0019	.0006L .0019L
3.1496	4.7244	-.0008 0	f6 -.0014 -.0023	.0006L .0023L
4.7244	7.0866	-.0010 0	f6 -.0016 -.0026	.0006L .0026L





ROTATING CONE													
Rear Wheels (Semi-floating Axles)		Rear Wheels (UNIT-BEARING) (Semi-floating Axles)		Pinion						Differential		Transaxles Transmissions Transfer Cases Cross Shafts Non-adjustable	
Non-adjustable		Non-adjustable		Clamped		Collapsible Spacer		Non-adjustable		Non-adjustable		Non-adjustable	
Shaft O.D. Deviation	Resultant Fit	Shaft O.D. Deviation	Resultant Fit	Shaft O.D. Deviation	Resultant Fit	Shaft O.D. Deviation	Resultant Fit	Shaft O.D. Deviation	Resultant Fit	Shaft O.D. Deviation	Resultant Fit	Shaft O.D. Deviation	Resultant Fit
µm	µm	µm	µm	µm	µm	µm	µm	µm	µm	µm	µm	µm	µm
+51	51T	+56	56T	+38	38T	+30	30T	+51	51T	+102	102T	+38	38T
+38	25T	+38	25T	+25	13T	+18	5T	+38	25T	+64	51T	+25	12T
+76	76T			+63	63T			+76	76T	+102	102T	+64	64T
+51	26T			+38	13T			+51	26T	+76	51T	+38	13T
in.	in.	in.	in.	in.	in.	in.	in.	in.	in.	in.	in.	in.	in.
+0.020	.0020T	+0.022	.0022 T	+0.015	.0015T	+0.012	.0012T	+0.020	.0020T	+0.040	+0.040T	+0.015	.0015T
+0.015	.0010T	+0.015	.0010 T	+0.010	.0005T	+0.007	.0002T	+0.015	.0010T	+0.025	.0020T	+0.010	.0005T
+0.030	.0030T			.0025	.0025T			+0.030	.0030T	+0.040	.0040T	+0.025	.0025T
+0.020	.0010T			.0015	.0005T			+0.020	.0010T	+0.025	.0020T	+0.015	.0005T

ROTATING CONE																			
Rear Wheels (Semi-floating Axles)		Rear Wheels (UNIT-BEARING) (Semi-floating Axles)		Pinion						Differential		Transaxles Transmissions Transfer Cases Cross Shafts Non-adjustable							
Non-adjustable		Non-adjustable		Clamped		Collapsible Spacer		Non-adjustable		Non-adjustable		Non-adjustable							
Shaft O.D. Deviation	Resultant Fit	Shaft O.D. Deviation	Resultant Fit	Shaft O.D. Deviation	Resultant Fit	Shaft O.D. Deviation	Resultant Fit	Shaft O.D. Deviation	Resultant Fit	Shaft O.D. Deviation	Resultant Fit	Shaft O.D. Deviation	Resultant Fit						
µm	µm	µm	µm	µm	µm	µm	µm	µm	µm	µm	µm	µm	µm						
p6	+35 +22	47T 22T	p6	+35 +22	47T 22T	k6	+15 +2	27T 2T	k6	+15 +2	27T 2T	p6	+35 +22	47T +22	+56 22T	68T +35	m6	+21 +8	33T 8T
p6	+42 +26	54T 26T	p6	+42 +26	54T 26T	k6	+18 +2	30T 2T	k6	+18 +2	30T 2T	p6	+42 +26	54T 26T	+68 +43	80T 43T	m6	+25 +9	37T 9T
p6	+51 +32	66T 32T				k6	+21 +2	36T 2T	k6	+21 +2	36T 2T	p6	+51 +32	66T 32T	+89 +59	104T 59T	m6	+30 +11	45T 11T
n6	+45 +23	65T 23T				j6	+13 -9	33T 9L				n6	+45 +23	65T 23T	+114 +79	134T 79T	m6	+35 +13	55T 13T
n6	+52 +27	77T 29T				j6	+14 -11	39T 11L				n6	+52 +27	77T 29T	+140 +100	165T 100T	m6	+40 +15	66T 15T
in.	in.	in.	in.	in.	in.	in.	in.	in.	in.	in.	in.	in.	in.						
p6	+0.013 +0.008	.0018T .0008T	p6	+0.013 +0.008	.0018T .0008T	k6	+0.006 +0.001	.0011T .0001T	k6	+0.006 +0.001	.0011T .0001T	p6	+0.013 +0.008	.0018T .0008T	+0.022 +0.014	.0027T .0014T	m6	+0.008 +0.003	.0013T .0003 T
p6	+0.016 +0.010	.0021T .0010T	p6	+0.016 +0.010	.0021T .0010T	k6	+0.007 +0.001	.0012T .0001T	k6	+0.007 +0.001	.0012T .0001T	p6	+0.016 +0.010	.0021T .0010T	+0.028 +0.018	.0033T .0018T	m6	+0.010 +0.004	.0015T .0004T
p6	+0.021 +0.014	.0027T .0014T				k6	+0.008 -0.001	.0014T .0001L	k6	+0.008 +0.001	.0014T .0001L	p6	+0.021 +0.014	.0027T .0014T	+0.034 +0.022	.0040T .0022T	m6	+0.012 +0.005	.0018T .0005T
n6	+0.019 +0.010	.0027T .0010T				j6	+0.005 -0.004	.0013T .0004L				n6	+0.019 +0.010	.0027T .0010T	+0.044 +0.030	.0052T .0030T	m6	+0.014 +0.005	.0022T .0005T
n6	+0.022 +0.012	.0032T .0012T				j6	+0.006 -0.004	.0016T .0004L				n6	+0.022 +0.012	.0032T .0012T	+0.056 +0.040	.0066T .0040T	m6	+0.016 +0.006	.0026T .0006T

FITTING PRACTICES - continued

**FITTING GUIDELINES FOR INCH BEARINGS  
AUTOMOTIVE EQUIPMENT BEARING CLASSES 4 AND 2**

Deviation from nominal (minimum) bearing bore and resultant fit (µm - 0.001 inch)

HOUSING BORE (µm - INCHES)													
	CUP O.D.			ROTATING CUP				STATIONARY CUP					
	over	incl.	Tolerance	Front Wheels	Rear Wheels	Rear Wheels	(Semi-Floating Axles)	Differential	(Split Seat)	Trans-missions	Transfer Cases	Pinion	Differential
				(Full Floating Trailer Wheels)		Adjustable (TS)	Clamped (TSU)	Adjustable	Adjustable	Adjustable	Non-Adjustable	Transmission	Transfer Cases
	Non-adjustable	Resultant Fit	Housing Bore Deviation	Resultant Fit	Housing Bore Deviation								
mm	mm	µm	µm	µm	µm	µm	µm	µm	µm	µm	µm	µm	µm
Inch System Bearings Classes 4 and 2	0	76.200	+25 0	-51 -13	76T 13T	+38 +76	13L 76L	+25 +51	0 51L	0 +25	25T 25L	-38 -13	63T 13T
	76.200	127.00	+25 0	-77 -25	102T 25T	+38 +76	13L 76L	+25 +51	0 51L	0 +25	25T 25L	-51 -25	76T 25T
	127.00	304.800	+25 0	-77 -25	102T 25T			0 +51	25T 51L	0 +51	25T 51L	-77 -25	102T 25T
	in.	in.	in.	in.	in.	in.	in.	in.	in.	in.	in.	in.	in.
	0	3.0000	+0.010 0	-0.0020 -0.0005	.0030T .0005T	+0.0015 +0.0030	.0005L .0030L	+0.0010 +0.0020	0 .0020L	0 +0.0010	.0010T .0010L	-0.0015 -0.0005	.0025T .0005T
	3.0000	5.0000	+0.010 0	-0.0030 -0.0010	.0040T .0010T	+0.0015 +0.0030	.0005L .0030L	+0.0010 +0.0020	0 .0020L	0 +0.0010	.0010T .0010L	-0.0020 -0.0010	.0030T .0010T
	5.0000	12.0000	+0.010 0	-0.0030 -0.0010	.0040T .0010T			0 +0.0020	.0010T .0020L	0 +0.0020	.0010T .0020L	-0.0030 -0.0010	.0040T .0010T

Aluminum housings min. fit of .001 inch per inch of cup O.D.  
Magnesium housings min. fit of .0015 inch per inch of cup O.D.



FITTING PRACTICES - continued

**FITTING GUIDELINES FOR METRIC BEARINGS  
AUTOMOTIVE EQUIPMENT BEARING CLASSES K AND N**

Deviation from nominal (minimum) bearing bore and resultant fit (µm - inches)

HOUSING BORE (µm - INCHES)																	
CUP O.D.			ROTATING CUP			STATIONARY CUP											
			Front Wheels Rear Wheels (Full Floating Axles)			Rear Wheels (Semi-floating Axles)		Differential (Split Seat)		Transmissions Transfer Cases Cross Shafts			Pinion Differential (Solid Seat) Transaxles Transmission Transfer Cases				
			Non-adjustable			Adjustable (TS) Clamped (TSU)		Adjustable		Adjustable			Non-Adjustable				
over	incl.	Tolerance	Housing Bore Deviation	Resultant Fit		Housing Bore Deviation	Resultant Fit	Housing Bore Deviation	Resultant Fit	Housing Bore Deviation	Resultant Fit	Housing Bore Deviation	Resultant Fit	Housing Bore Deviation	Resultant Fit		
µm	µm	µm	µm	µm		µm	µm	µm	µm	µm	µm	µm	µm	µm	µm		
30	50	0 -14	R7	-50 -25	50T 11T	G7	+9 +34	9L 48L	H7	0 +25	0 39L	K6	-13 +3	13T 17L	R7	-50 -25	50T 11T
50	65	0 -16	R7	-60 -30	60T 14T	G7	+10 +40	10L 56L	H7	0 +30	0 46L	K6	-15 +4	15T 20L	R7	-60 -30	60T 14T
65	80	0 -16	R7	-62 -32	62T 16T										R7	-62 -32	62T 16T
80	100	0 -18	R7	-73 -38	73T 20T	G7	+12 +47	12L 65L	H7	0 +35	0 53L	K6	-18 +4	18T 22L	R7	-73 -38	73T 20T
100	120	0 -18	R7	-76 -41	76T 23T										R7	-76 -41	76T 23T
120	140	0 -20	R7	-88 -48	88T 28T	G7	+14 +54	14L 74L	J7	-14 +26	14T 46L	K6	-21 +4	21T 24L	R7	-88 -48	88T 28T
140	150	0 -20	R7	-90 -50	90T 30T										R7	-90 -50	90T 30T
150	160	0 -25	R7	-90 -50	90T 25T	G7	+14 +54	14L 79L	J7	-14 +26	14T 51L	K6	-21 +4	21T 29L	R7	-90 -50	90T 25T
160	180	0 -25	R7	-93 -53	93T 28T										R7	-93 -53	93T 28T
180	200	0 -30	R7	-106 -60	106T 30T				J7	-16 +30	16T 60L	J7	-16 +30	16T 60L	R7	-106 -60	106T 30T
200	225	0 -30	R7	-109 -63	109T 33T										R7	-109 -63	109T 33T
225	250	0 -30	R7	-113 -67	113T 37T										R7	-113 -67	113T 37T
250	280	0 -35	R7	-126 -74	126T 39T				J7	-16 +36	16T 71L	J7	-16 +36	16T 71L	R7	-126 -74	126T 39T
280	315	0 -35	R7	-130 -78	130T 43T										R7	-130 -78	130T 43T
in.	in.	in.	in.	in.		in.	in.	in.	in.	in.	in.	in.	in.	in.	in.	in.	
1.1811	1.9685	0 -0.006	R7	-0.020 -0.010	.0020T .0004T	G7	+0.004 +0.014	.0004L .0020L	H7	0 +0.010	0 .0016L	K6	-0.005 +0.001	.0005T .0007L	R7	-0.020 -0.010	.0020T .0004T
1.9685	2.5591	0 -0.006	R7	-0.023 -0.011	.0023T .0005T	G7	+0.004 +0.016	.0004L .0022L	H7	0 +0.012	0 .0018L	K6	-0.006 +0.001	.0006T .0007L	R7	-0.023 -0.011	.0023T .0005T
2.5591	3.1496	0 -0.006	R7	-0.023 -0.011	.0023T .0005T										R7	-0.023 -0.011	.0023T .0005T
3.1496	3.9370	0 -0.007	R7	-0.029 -0.015	.0029T .0008T	G7	+0.005 +0.019	.0005L .0026L	H7	0 +0.014	0 .0021L	K6	-0.007 +0.002	.0007T .0009L	R7	-0.029 -0.015	.0029T .0008T
3.9370	4.7244	0 -0.007	R7	-0.029 -0.015	.0029T .0008T										R7	-0.029 -0.015	.0029T .0008T
4.7244	5.5118	0 -0.008	R7	-0.035 -0.019	.0035T .0011T	G7	+0.006 +0.022	.0006L .0030L	J7	-0.006 +0.010	.0006T .0018L	K6	-0.008 +0.002	.0008T .0010L	R7	-0.035 -0.019	.0035T .0011T
5.5118	5.9055	0 -0.008	R7	-0.035 -0.019	.0035T .0011T										R7	-0.035 -0.019	.0035T .0011T
5.9055	6.2992	0 -0.010	R7	-0.035 -0.019	.0035T .0009T	G7	+0.006 +0.022	.0006L .0032L	J7	-0.006 +0.010	.0006T .0020L	K6	-0.008 +0.002	.0008T .0012L	R7	-0.035 -0.019	.0035T .0009T
6.2992	7.0866	0 -0.010	R7	-0.035 -0.019	.0035T .0009T										R7	-0.035 -0.019	.0035T .0009T
7.0866	7.8740	0 -0.012	R7	-0.042 -0.024	.0042T .0012T				J7	-0.007 +0.011	.0007T .0023L	J7	-0.007 +0.011	.0007T .0023L	R7	-0.042 -0.024	.0042T .0012T
7.8740	8.8583	0 -0.012	R7	-0.042 -0.024	.0042T .0012T										R7	-0.042 -0.024	.0042T .0012T
8.8583	9.8425	0 -0.012	R7	-0.042 -0.024	.0042T .0012T										R7	-0.042 -0.024	.0042T .0012T
9.8425	11.0236	0 -0.014	R7	-0.047 -0.027	.0047T .0013T				J7	-0.007 +0.013	.0007T .0027L	J7	-0.007 +0.013	.0007T .0027L	R7	-0.047 -0.027	.0047T .0013T
11.0236	12.4016	0 -0.014	R7	-0.047 -0.027	.0047T .0013T										R7	-0.047 -0.027	.0047T .0013T

Aluminum housings min. fit of .001 inch per inch of cup O.D.  
Magnesium housings min. fit of .0015 inch per inch of cup O.D.

FITTING PRACTICES - continued

**Non-ferrous housings**

Care should be taken when pressing cups into aluminum or magnesium housings to avoid metal pick up. This may result in unsatisfactory fits, backing, and alignment from debris trapped between the cup and backing shoulder. Preferably, the cup should be frozen or the housing heated, or both, during assembly. Also, a special lubricant may be used to ease assembly. In some cases, cups are mounted in steel inserts which are attached to the aluminum or magnesium housings. Table fits may then be used. Where the cup is fitted directly into an aluminum housing, it is suggested that a minimum tight fit of 1.0 µm per mm (0.0010 in. per in.) of cup outside diameter be used. For a magnesium housing, a minimum tight fit of 1.5 µm per mm (0.0015 in. per in.) of cup outside diameter is suggested.

**Hollow shafts**

In case of a thin section hollow shaft, the fits mentioned in the tables for industrial applications should be increased to avoid possible cone creeping under some load conditions.

**Heavy-duty fitting practice**

Where heavy-duty loads, shock loads or high speeds are involved, the heavy-duty fitting practice should be used, regardless of whether the cone seats are ground or unground. Where it is impractical to grind the shaft O.D. for the cone seats, the tighter heavy-duty fitting practice should be followed. In this case the turned shaft O.D. should not exceed a maximum surface finish of 3.2 µm (125 µin) arithmetic average.

The average interference cone fit for inch bearings above 76.2 mm (3 in.) bore should be 0.5 µm per mm (0.0005 in. per in.) of bearing bore. See inch fitting practice tables for cones with smaller bores. The minimum fit should not be less than 25 µm (0.0010 in.) tight. If the shaft diameter is held to the same tolerance as the bearing bore, use the average interference fit. For example, average interference fit between a 609.6 mm (24 in.) bore cone and shaft will be 305 µm (0.0120 in.). The fit range will be 305 µm (0.0120 in.) tight plus or minus the bearing bore tolerance. See metric fitting practice tables for heavy-duty metric cone fitting practice.

**Double-row assemblies with double cups**

Non-rotating double outer races of types TDO and TNA bearings are generally mounted with loose fits to permit assembly and disassembly (Fig. A-24). The loose fit also permits axial floating when the bearing is mounted in conjunction with an axially fixed (locating) bearing on the other end of the shaft. Double outer races types CD and DC can be pinned to prevent rotation in the housing. Fitting values can be taken from general industrial guidelines.

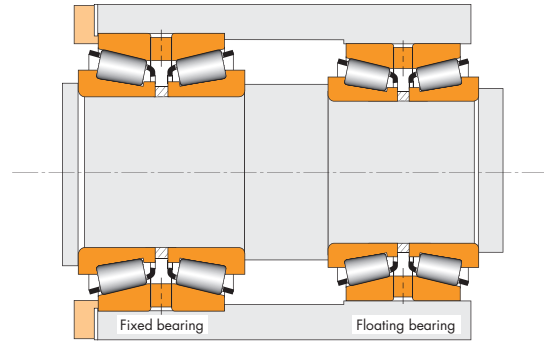

Fig. A-24 Double-row bearing arrangement assembled with loose fit.

**Bearing assemblies SR, TNA, TNASW, TNASWE types**

The tolerance and fits for bearing types SR, TNA, TNASW, and TNASWE are tabulated along with the other dimensions in the bearing tables.

**CAUTION: Failure to use the specified fits may result in improper bearing setting. Reduced bearing performance or malfunction may occur. This may cause damage to machinery in which the bearing is a component. If interference fits are either greater or less than those specified, the mounted bearing setting will be other than intended.**



FITTING PRACTICES - continued

SHAFT AND HOUSING FITS

RADIAL BALL AND CYLINDRICAL ROLLER BEARINGS

These charts are guidelines for specifying shaft and housing fits related to particular operating conditions.

SHAFT											
Ball Bearings (For all nominal diameters)			Operating Conditions	Examples	Cylindrical Roller Bearings (Except 5200 Series)						
Loads		Shaft Tolerance Symbol			Loads		Shaft Diameter mm		Shaft Tolerance Symbol <sup>(1)</sup>	Shaft Diameter inch	
Lower Load Limit	Upper Load Limit			Lower Load Limit	Upper Load Limit					over	incl.
<b>Inner Ring Stationary</b>			Inner ring to be easily displaced on shaft	Wheels Non-rotating shafts	0	C <sup>(6)</sup>	All	g6	All		
0	C <sub>e</sub> <sup>(7)</sup>	g6									
<b>Inner Ring Rotating or Indeterminate</b>			Inner ring does not need to be easily displaced	Tension pulleys	0	C	All	h6	All		
0	C <sub>e</sub>	h6									
<b>Inner Ring Rotating or Indeterminate</b>			Light loads	Electrical apparatus Machine tools Pumps Ventilators Industrial trucks	0	0.08C	over	incl.	j6 <sup>(8)</sup> k6 <sup>(4)</sup> m6 <sup>(5)</sup> n6 p6	over	incl.
0	0.07 C <sub>e</sub>	j6 <sup>(2)</sup>					0	40		140	0
<b>Inner Ring Rotating or Indeterminate</b>			Normal loads	Electrical motors Turbines Pumps Combustion engines Gear transmissions etc.	0.08C	0.18C	0	40	k5	0	1.57
0.07 C <sub>e</sub>	0.15 C <sub>e</sub>	k5					40	100	m5	1.57	
<b>Inner Ring Rotating or Indeterminate</b>			Heavy loads Shock loads	Rail vehicles Traction motors	0.18C	C	140	320	m6	3.94	5.51
0.15 C <sub>e</sub>	C <sub>e</sub>	m5					140	320	n6	5.51	
<b>Inner Ring Rotating or Indeterminate</b>			Pure thrust loads	All	0.18C	C	320	500	p6	12.60	19.68
0	C <sub>e</sub>	j6 <sup>(3)</sup>					320	500	r6 <sup>(3)</sup>	12.60	
<b>Thrust Loads</b>							500	r7 <sup>(3)</sup>	19.68	–	
										Not suggested, consult your Timken representative.	

(1) For solid shaft. See pages A61 for numerical values.  
 (2) Use j5 for accurate applications.  
 (3) Bearings with greater than nominal clearance must be used.  
 (4) Use k5 for accurate applications.  
 (5) Use m5 for accurate applications.  
 (6) C = Dynamic Load Rating.  
 (7) C<sub>e</sub> = Extended Dynamic Load Rating (Ball Bearings).  
 (8) Use j5 for accurate applications.

HOUSING			
Operating Conditions	Examples	Housing Tolerance Symbol <sup>(1)</sup>	Outer Ring Displaceable Axially
<b>Outer Ring Rotating</b>			
Heavy loads with thin-wall housing	Crane support wheels Wheel hubs (roller bearings) Crank bearings	P6	No
Normal to heavy loads	Wheel hubs (ball bearings) Crank bearings	N6	No
Light loads	Conveyor rollers Rope sheaves Tension pulleys	M6	No
<b>Indeterminate Load Direction</b>			
Heavy shock loads	Electric traction motors	M7	No
Normal to heavy loads, axial displacement of outer ring not required.	Electric motors Pumps Crankshaft main bearings	K6	No, normally
Light to normal loads, axial displacement of outer ring desired.	Electric motors Pumps Crankshaft main bearings	J6	Yes, normally
<b>Outer Ring Stationary</b>			
Shock loads, temporary complete unloading	Heavy rail vehicles	J6	Yes, normally
All loads	One-piece housing	H6	Easily
	Radially split housing	H7	Easily
Heat supplied through shaft	Drier cylinders	G7	Easily

\* Below this line, housing can either be one piece or split; above this line, a split housing is not suggested.

(1) Cast iron steel housing. See pages A61 to A72 for numerical values.  
 Where wider tolerances are permissible, P7, N7, M7, K7, J7 and H7 values may be used in place of P6, N6, M6, K6, J6, and H6 values respectively.

**FITTING PRACTICES - continued**

**RADIAL BALL BEARINGS  
ABEC 1 AND ABEC 3 BALL BEARINGS**

**Shaft and housing fits**

The tables on the following pages show information supplemental to and coherent with that found on pages A125 through A139 as applied to ball bearings. Actual shaft and housing diameters are listed for ABEC 1, ABEC 3 and angular contact 7000WN Series. These suggestions can be used for most applications having light to normal loads. Shaft and housing fits for wide inner ring ball bearings are found on page A133.

**ABEC 7 BALL BEARINGS**

**Shaft fits**

As a general rule, it is suggested that the shaft size and tolerance for seating ABEC 7 super precision bearings be the same as the bearing bore thus producing an average line-to-line fit. For larger shaft sizes, the average fit increases to a slight interference.

**EXAMPLE**

Bore Size, Inches	Shaft Diameter, Inches	Resultant Mounting Fits, Inches	Average Fit
Max. 2.1654	Min. 2.1652	.0002 tight	line-to-line
Min. 2.1652	Max. 2.1654	.0002 loose	

**HOUSING FITS**

Under normal conditions of rotating shaft, the outer ring is stationary and should be mounted with a hand push or light tapping fit. Should the housing be the rotating member, the same fundamental considerations apply in mounting the outer race as in the case of an inner ring mounted on a rotating shaft.

As a general rule, the minimum housing bore dimensions for super precision bearings may be established as the same as the maximum bearing outside diameter. If the bearing O.D. tolerance is .0003 inch, the maximum housing bore should be established as .0003 inch larger than the minimum housing bore dimension.

**EXAMPLE**

Outside Diameter, Inches	Housing Bore, Inches	Resultant Mounting Fits, Inches	Average Fit Inches
Max. 3.5433	Min. 3.5433	.0000 tight	.0003 loose
Min. 3.5430	Max. 3.5436	.0006 loose	

On high-speed applications, it is extremely important that the floating bearing or pair can move axially to compensate for thermal changes. It cannot float laterally if restricted by a tight housing bore or by the radial expansion of the bearing itself. Cases involving unusual conditions should be submitted to your Timken representative for suggestions.

It is equally important that all shaft and housing shoulders be absolutely square and that the faces of the spacers be square and parallel.

**Selective assembly**

Under certain conditions it may be desirable to control fits more accurately without the added expense of using closer-tolerance bearings and mating parts. This can be accomplished by selective assembly of bearings, shafts and housings after they have been sized and grouped according to bores and outside diameters. Generally, however, it is more satisfactory for production and servicing to use closer shaft and housing tolerances with bearings having a higher degree of precision.

Bearings with coded bores and O.D.s are available on special order to facilitate this selective assembly process.

**Shafts and housing fillets**

The suggested shaft and housing fillet radii listed in the dimension tables of the product catalogs should be used to assure proper seating of the bearings against shaft and housing shoulders. The manufacturing tolerances on bearing corner radii are such that the corners will clear the cataloged fillet radii when the bearings are tightly seated against shoulders. Shaft and housing radii and shoulders should be free from nicks and burrs. Whenever possible, undercutting of bearing seats and adjacent shoulders per figure below is advisable to help avoid tapered bearing seats and assure clearing corners.

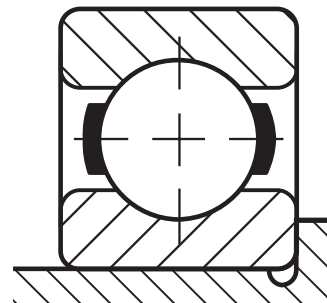



FITTING PRACTICES - continued

SHAFT AND HOUSING FITS RADIAL BALL BEARING

Shaft fits, ABEC 1, ABEC 3

Note: These tables are to be used for applications where only one ring (either inner or outer) has an interference fit with its shaft and housing. The guidelines for operating conditions covering these tables are found on page A123. In cases where interference fits are used for both rings, bearings with a special internal clearance may be required. Shaft diameter dimensions are for solid steel shafts. Consult your Timken representative when using hollow shafts.

SHAFT FITS, ABEC 1, ABEC 3																				
Basic Bearing Number	Bore Tolerance				These diameters result in shaft to bearing bore fit which closely conforms to k5 listed on pages A66 and A72								These diameters result in shaft to bearing bore fit which closely conforms to g6 listed on pages A66 and A72							
					Shaft Rotating, Load Stationary or Shaft Stationary, Load Rotating (Typical Inner Ring Rotation)				Shaft Stationary, Load Stationary or Shaft Rotating, Load Rotating (Typical Outer Ring Rotation)											
	Shaft Diameter		Mean Fit Tight		Shaft diameter		Mean Fit Loose													
Max.	Min.	Max.	Min.	ABEC 1	ABEC 3	Max.	Min.	ABEC 1	ABEC 3											
mm	in.	mm	in.	mm	in.	mm	in.	mm	in.	mm	in.	mm	in.	mm	in.					
<b>Extra-Small 30, S, F-Flanged Series</b>																				
33K3, F33K3	3.175	0.1250	3.167	0.1247	3.180	0.1252	3.175	0.1250	0.006	0.00025	0.005	0.00020	3.170	0.1248	3.162	0.1245	0.005	0.00020	0.006	0.00025
33K4	3.175	0.1250	3.167	0.1247	3.180	0.1252	3.175	0.1250	0.006	0.00025	0.005	0.00020	3.170	0.1248	3.162	0.1245	0.005	0.00020	0.006	0.00025
33K5	4.762	0.1875	3.754	0.1872	4.768	0.1877	4.762	0.1875	0.006	0.00025	0.005	0.00020	4.752	0.1873	4.750	0.1870	0.005	0.00020	0.006	0.00025
34K	4.000	0.1575	3.992	0.1572	4.006	0.1577	4.001	0.1575	0.006	0.00025	0.005	0.00020	3.995	0.1573	3.988	0.1570	0.005	0.00020	0.006	0.00025
35K	5.000	0.1969	4.992	0.1966	5.006	0.1971	5.001	0.1969	0.006	0.00025	0.005	0.00020	4.996	0.1967	4.989	0.1964	0.005	0.00020	0.006	0.00025
36K	6.000	0.2362	5.992	0.2359	6.005	0.2364	5.999	0.2362	0.006	0.00025	0.005	0.00020	5.994	0.2360	5.987	0.2357	0.005	0.00020	0.006	0.00025
37K	7.000	0.2756	6.992	0.2753	7.005	0.2758	6.998	0.2755	0.005	0.00020	0.004	0.00015	6.995	0.2754	6.985	0.2750	0.006	0.00025	0.008	0.00030
38K,38KV	8.000	0.3150	7.992	0.3147	8.006	0.3152	7.998	0.3149	0.005	0.00020	0.004	0.00015	7.996	0.3148	7.986	0.3144	0.006	0.00025	0.008	0.00030
39K	9.000	0.3543	8.992	0.3540	9.004	0.3545	8.997	0.3542	0.005	0.00020	0.004	0.00015	8.994	0.3541	8.984	0.3537	0.006	0.00025	0.008	0.00030
S1K,S1K7,FS1K7	6.350	0.2500	6.342	0.2497	6.355	0.2502	6.347	0.2499	0.005	0.00020	0.004	0.00015	6.345	0.2498	6.335	0.2494	0.006	0.00025	0.008	0.00030
S3K,FS3K	9.525	0.3750	9.517	0.3747	9.530	0.3752	9.522	0.3749	0.005	0.00020	0.004	0.00015	9.520	0.3748	9.510	0.3744	0.006	0.00025	0.008	0.00030
S5K	12.700	0.5000	12.692	0.4997	12.705	0.5002	12.697	0.4999	0.005	0.00020	0.004	0.00015	12.695	0.4998	12.682	0.4993	0.008	0.00030	0.009	0.00035
S7K	15.875	0.6250	15.867	0.6247	15.880	0.6252	15.872	0.6249	0.005	0.00020	0.004	0.00015	15.870	0.6248	15.857	0.6243	0.008	0.00030	0.009	0.00035
S8K	19.050	0.7500	19.040	0.7496	19.060	0.7504	19.053	0.7501	0.011	0.00045	0.009	0.00035	19.042	0.7497	19.030	0.7492	0.009	0.00035	0.011	0.00045
S9K	22.225	0.8750	22.215	0.8746	22.235	0.8754	22.228	0.8751	0.011	0.00045	0.009	0.00035	22.217	0.8747	22.205	0.8742	0.009	0.00035	0.011	0.00045
S10K	25.400	1.0000	25.390	0.9996	25.410	1.0004	25.403	1.0001	0.011	0.00045	0.009	0.00035	25.392	0.9997	25.380	0.9992	0.009	0.00035	0.011	0.00045
S11K	28.575	1.1250	28.565	1.1246	28.585	1.1254	28.578	1.1251	0.011	0.00045	0.009	0.00035	28.567	1.1247	28.555	1.1242	0.009	0.00035	0.011	0.00045
S12K	31.750	1.2500	31.737	1.2495	31.763	1.2505	31.753	1.2501	0.014	0.00055	0.011	0.00045	31.740	1.2496	31.725	1.2490	0.011	0.00045	0.014	0.00055
F2DD-2	3.183	0.1253	3.175	0.1250	3.175	0.1250	3.167	0.1247	0.008 <sup>(1)</sup>	0.00030	0.006 <sup>(1)</sup>	0.00025	3.175	0.1250	3.167	0.1247	0.008	0.00030	0.006	0.00025
F2	4.770	0.1878	4.762	0.1875	4.762	0.1875	4.755	0.1872	0.008 <sup>(1)</sup>	0.00030	0.006 <sup>(1)</sup>	0.00025	4.762	0.1875	4.755	0.1872	0.008	0.00030	0.006	0.00025
F3	4.770	0.1878	4.762	0.1875	4.762	0.1875	4.755	0.1872	0.008 <sup>(1)</sup>	0.00030	0.006 <sup>(1)</sup>	0.00025	4.762	0.1875	4.755	0.1872	0.008	0.00030	0.006	0.00025
F4	6.358	0.2503	6.350	0.2500	6.350	0.2500	6.342	0.2497	0.008 <sup>(1)</sup>	0.00030	0.006 <sup>(1)</sup>	0.00025	6.350	0.2500	6.342	0.2497	0.008	0.00030	0.006	0.00025
F5	7.946	0.3128	7.938	0.3125	7.938	0.3125	7.930	0.3122	0.008 <sup>(1)</sup>	0.00030	0.006 <sup>(1)</sup>	0.00025	7.938	0.3125	7.930	0.3122	0.008	0.00030	0.006	0.00025

<sup>(1)</sup> Mean fit loose. These sizes have plus bore tolerances.

FITTING PRACTICES - continued

SHAFT AND HOUSING FITS RADIAL BALL BEARING

Shaft fits, ABEC 1, ABEC 3

Note: These tables are to be used for applications where only one ring (either inner or outer) has an interference fit with its shaft and housing. The guidelines for operating conditions covering these tables are found on page A123. In cases where interference fits are used for both rings, bearings with a special internal clearance may be required. Shaft diameter dimensions are for solid steel shafts. Consult your Timken representative when using hollow shafts.

SHAFT FITS, ABEC 1, ABEC 3																				
Basic Bearing Number	Bore Tolerance				These diameters result in shaft to bearing bore fit which closely conforms to k5 listed on pages A66 and A72								These diameters result in shaft to bearing bore fit which closely conforms to g6 listed on pages A66 and A72							
					Shaft Rotating, Load Stationary or Shaft Stationary, Load Rotating				Shaft Stationary, Load Stationary or Shaft Rotating, Load Rotating				Shaft Stationary, Load Stationary or Shaft Rotating, Load Rotating				Shaft Stationary, Load Stationary or Shaft Rotating, Load Rotating			
	Max.		Min.		Shaft Diameter		Mean Fit Tight		Mean Fit Loose		Shaft Diameter		Mean Fit Loose		Shaft Diameter		Mean Fit Loose			
	mm	in.	mm	in.	mm	in.	mm	in.	mm	in.	mm	in.	mm	in.	mm	in.	mm	in.		
<b>9100, 9300, 200, 300, 400, 5200, 5300 SERIES</b>																				
00	10	0.3937	9.992	0.3934	10.005	0.3939	9.997	0.3936	0.005	0.0002	0.004	0.00015	9.995	0.3935	9.985	0.3931	0.006	0.00025	0.008	0.00030
01	12	0.4724	11.992	0.4721	12.004	0.4726	11.996	0.4723	0.005	0.0002	0.004	0.00015	11.994	0.4722	11.981	0.4717	0.008	0.00030	0.009	0.00035
02	15	0.5906	14.992	0.5903	15.006	0.5908	14.999	0.5905	0.005	0.0002	0.004	0.00015	14.996	0.5904	14.983	0.5899	0.008	0.00030	0.009	0.00035
03	17	0.6693	16.992	0.6690	17.005	0.6695	16.998	0.6692	0.005	0.0002	0.004	0.00015	16.995	0.6691	16.982	0.6686	0.008	0.00030	0.009	0.00035
04	20	0.7874	19.990	0.7870	20.010	0.7879	20.002	0.7875	0.013	0.0005	0.009	0.00035	19.992	0.7871	19.980	0.7866	0.009	0.00035	0.011	0.00045
05	25	0.9843	24.990	0.9839	25.014	0.9848	25.004	0.9844	0.013	0.0005	0.009	0.00035	24.994	0.9840	24.981	0.9835	0.009	0.00035	0.011	0.00045
06	30	1.1811	29.990	1.1807	30.010	1.1816	30.002	1.1812	0.013	0.0005	0.009	0.00035	29.992	1.1808	29.980	1.1803	0.009	0.00035	0.011	0.00045
07	35	1.3780	34.987	1.3775	35.014	1.3785	35.004	1.3781	0.014	0.0006	0.011	0.00045	34.991	1.3776	34.976	1.3770	0.011	0.00045	0.014	0.00055
08	40	1.5748	39.987	1.5743	40.013	1.5753	40.002	1.5749	0.014	0.0006	0.011	0.00045	39.990	1.5744	39.975	1.5738	0.011	0.00045	0.014	0.00055
09	45	1.7717	44.987	1.7712	45.014	1.7722	45.004	1.7718	0.014	0.0006	0.011	0.00045	44.991	1.7713	44.976	1.7707	0.011	0.00045	0.014	0.00055
10	50	1.9685	49.987	1.9680	50.013	1.9690	50.002	1.9686	0.014	0.0006	0.011	0.00045	49.990	1.9681	49.974	1.9675	0.011	0.00045	0.014	0.00055
11	55	2.1654	54.985	2.1648	55.016	2.1660	55.004	2.1655	0.017	0.0007	0.014	0.00055	54.991	2.1650	54.973	2.1643	0.011	0.00045	0.014	0.00055
12	60	2.3622	59.985	2.3616	60.015	2.3628	60.002	2.3623	0.017	0.0007	0.014	0.00055	59.990	2.3618	59.972	2.3611	0.011	0.00045	0.014	0.00055
13	65	2.5591	64.985	2.5585	65.016	2.5597	65.004	2.5592	0.017	0.0007	0.014	0.00055	64.991	2.5587	64.973	2.5580	0.011	0.00045	0.014	0.00055
14	70	2.7559	69.985	2.7553	70.015	2.7565	70.002	2.7560	0.017	0.0007	0.014	0.00055	69.990	2.7555	69.972	2.7548	0.011	0.00045	0.014	0.00055
15	75	2.9528	74.985	2.9522	75.016	2.9534	75.004	2.9529	0.017	0.0007	0.014	0.00055	74.991	2.9524	74.973	2.9517	0.011	0.00045	0.014	0.00055
16	80	3.1496	79.985	3.1490	80.015	3.1502	80.002	3.1497	0.017	0.0007	0.014	0.00055	79.990	3.1492	79.972	3.1485	0.011	0.00045	0.014	0.00055
17	85	3.3465	84.980	3.3457	85.019	3.3472	85.004	3.3466	0.020	0.0008	0.017	0.00065	84.988	3.3460	84.968	3.3452	0.013	0.00050	0.017	0.00065
18	90	3.5433	89.980	3.5425	90.018	3.5440	90.002	3.5434	0.020	0.0008	0.017	0.00065	89.987	3.5428	89.967	3.5420	0.013	0.00050	0.017	0.00065
19	95	3.7402	94.980	3.7394	95.019	3.7409	95.004	3.7403	0.020	0.0008	0.017	0.00065	94.988	3.7397	94.968	3.7389	0.013	0.00050	0.017	0.00065
20	100	3.9370	99.980	3.9362	100.018	3.9377	100.002	3.9371	0.020	0.0008	0.017	0.00065	99.987	3.9365	99.967	3.9357	0.013	0.00050	0.017	0.00065
21	105	4.1339	104.980	4.1331	105.019	4.1346	105.004	4.1340	0.020	0.0008	0.017	0.00065	104.988	4.1334	104.968	4.1326	0.013	0.00050	0.017	0.00065
22	110	4.3307	109.980	4.3299	110.018	4.3314	110.002	4.3308	0.020	0.0008	0.017	0.00065	109.987	4.3302	109.967	4.3294	0.013	0.00050	0.017	0.00065
<b>EXTRA-LARGE SERIES</b>																				
124, 224, 324	120	4.7244	119.980	4.7236	120.018	4.7251	120.002	4.7245	0.020	0.0008	0.017	0.00065	119.987	4.7239	119.967	4.7231	0.013	0.00050	0.017	0.00065
126, 226, 326	130	5.1181	129.975	5.1171	130.020	5.1189	130.002	5.1182	0.024	0.0010	0.019	0.00075	129.984	5.1175	129.962	5.1166	0.014	0.00055	0.019	0.00075
128, 228, 328	140	5.5118	139.975	5.5108	140.020	5.5126	140.002	5.5119	0.024	0.0010	0.019	0.00075	139.984	5.5112	139.962	5.5103	0.014	0.00055	0.019	0.00075
9130, 130, 230, 330	150	5.9055	149.975	5.9045	150.020	5.9063	150.002	5.9056	0.024	0.0010	0.019	0.00075	149.984	5.9049	149.962	5.9040	0.014	0.00055	0.019	0.00075
9132, 132, 232	160	6.2992	159.975	6.2982	160.020	6.3000	160.002	6.2993	0.024	0.0010	0.019	0.00075	159.984	6.2986	159.962	6.2977	0.014	0.00055	0.019	0.00075
9134, 134, 234	170	6.6929	169.975	6.6919	170.020	6.6937	170.002	6.6930	0.024	0.0010	0.019	0.00075	169.984	6.6923	169.962	6.6914	0.014	0.00055	0.019	0.00075
9136, 136, 236, 336	180	7.0866	179.975	7.0856	180.020	7.0874	180.002	7.0867	0.024	0.0010	0.019	0.00075	179.984	7.0860	179.962	7.0851	0.014	0.00055	0.019	0.00075
9138, 138, 238, 338	190	7.4803	189.970	7.4791	190.025	7.4813	190.005	7.4805	0.030	0.0012	0.024	0.00095	189.984	7.4797	189.956	7.4786	0.014	0.00055	0.020	0.00080
9140, 240, 340	200	7.8740	199.969	7.8728	200.025	7.8750	200.005	7.8742	0.030	0.0012	–	–	199.984	7.8734	199.954	7.8722	0.015	0.00060	–	–
9142, 242, 342	210	8.2677	212.509	8.2665	209.771	8.2587	210.002	8.2678	0.030	0.0012	–	–	209.987	8.2672	209.951	8.2658	0.015	0.00060	–	–
9144, 244, 344	220	8.6614	219.969	8.6602	220.025	8.6624	220.005	8.6616	0.030	0.0012	–	–	219.984	8.6608	219.954	8.6596	0.015	0.00060	–	–
9146, 246	230	9.0551	229.969	9.0539	230.025	9.0561	230.005	9.0553	0.030	0.0012	–	–	230.022	9.0545	229.951	9.0533	0.015	0.00060	–	–
248, 348	240	9.4488	239.969	9.4476	240.025	9.4498	240.005	9.4490	0.030	0.0012	–	–	239.984	9.4482	239.954	9.4470	0.015	0.00060	–	–
250	250	9.8425	249.964	9.8411	250.020	9.8434	250.005	9.8426	0.030	0.0012	–	–	250.022	9.8418	249.972	9.8406	0.015	0.00060	–	–
9152, 252, 352	260	10.2362	259.964	10.2348	260.027	10.2373	260.005	10.2364	0.036	0.0014	–	–	259.982	10.2355	259.951	10.2343	0.015	0.00060	–	–
9156, 256, 356	280	11.0236	279.964	11.0222	280.027	11.0247	280.005	11.0238	0.036	0.0014	–	–	279.982	11.0229	279.951	11.0217	0.015	0.00060	–	–
9160, 260	300	11.8110	299.964	11.8096	300.027	11.8121	300.005	11.8112	0.036	0.0014	–	–	299.982	11.8103	299.951	11.8091	0.015	0.00060	–	–
9164, 264	320	12.5984	319.964	12.5970	320.030	12.5996	320.005	12.5986	0.038	0.0015	–	–	319.982	12.5977	319.946	12.5963	0.015	0.00060	–	–
9180	400	15.7480	399.969	15.7464	400.030	15.7492	400.005	15.7482	0.038	0.0015	–	–	399.982	15.7473	399.946	15.7459	0.015	0.00060	–	–





FITTING PRACTICES - *continued*

**SHAFT FITS, 7000WN**

Note: These tables are to be used for applications where only one ring (either inner or outer) has an interference fit with its shaft and housing. The guidelines for operating conditions covering these tables are found on page A123. In cases where interference fits are used for both rings, bearings with a special internal clearance may be required. Shaft diameter dimensions are for solid steel shafts. Consult your Timken representative when using hollow shafts.

SHAFT FITS, 7000WN SINGLE ROW ANGULAR CONTACT BEARINGS										
Bearing Bore Number	Bearing Bore Diameter				Shaft Rotating, Load Stationary Shaft Diameter				Mean Tight Fit	
	Max.		Min.		Min.		Max.		mm	in.
	mm	in.	mm	in.	mm	in.	mm	in.		
00	10	0.3937	9.992	0.3934	9.997	0.3936	10.005	0.3939	0.005	0.0002
01	12	0.4724	11.991	0.4721	11.996	0.4723	12.004	0.4726	0.005	0.0002
02	15	0.5906	14.994	0.5903	14.999	0.5905	15.006	0.5908	0.005	0.0002
03	17	0.6693	16.993	0.6690	16.998	0.6692	17.005	0.6695	0.005	0.0002
04	20	0.7874	19.992	0.7871	19.997	0.7873	20.005	0.7876	0.005	0.0002
05	25	0.9843	24.994	0.9840	24.999	0.9842	25.006	0.9845	0.005	0.0002
06	30	1.1811	29.992	1.1808	29.997	1.1810	30.005	1.1813	0.005	0.0002
07	35	1.3780	34.994	1.3777	34.999	1.3779	35.009	1.3783	0.006	0.00025
08	40	1.5748	39.992	1.5745	39.997	1.5747	40.008	1.5751	0.006	0.00025
09	45	1.7717	44.994	1.7714	44.999	1.7716	45.009	1.7720	0.006	0.00025
10	50	1.9685	49.992	1.9682	49.997	1.9684	50.008	1.9688	0.006	0.00025
11	55	2.1654	54.991	2.1650	54.999	2.1653	55.011	2.1658	0.009	0.00035
12	60	2.3622	59.990	2.3618	59.997	2.3621	60.010	2.3626	0.009	0.00035
13	65	2.5591	64.991	2.5587	64.999	2.5590	65.011	2.5595	0.009	0.00035
14	70	2.7559	69.990	2.7555	69.997	2.7558	70.010	2.7563	0.009	0.00035
15	75	2.9528	74.991	2.9524	74.999	2.9527	75.011	2.9532	0.009	0.00035
16	80	3.1496	79.990	3.1492	79.997	3.1495	80.010	3.1500	0.009	0.00035
17	85	3.3465	84.988	3.3460	84.999	3.3464	85.014	3.3470	0.011	0.00045
18	90	3.5433	89.987	3.5428	89.997	3.5432	90.013	3.5438	0.011	0.00045
19	95	3.7402	94.988	3.7397	94.999	3.7401	95.014	3.7407	0.011	0.00045
20	100	3.9370	99.987	3.9365	99.997	3.9369	100.013	3.9375	0.011	0.00045
21	105	4.1339	104.988	4.1334	104.999	4.1338	105.014	4.1344	0.011	0.00045
22	110	4.3307	109.987	4.3302	109.997	4.3306	110.012	4.3312	0.011	0.00045
24	120	4.7244	119.987	4.7239	119.997	4.7243	120.012	4.7249	0.011	0.00045
26	130	5.1181	129.982	5.1174	129.997	5.1180	130.015	5.1187	0.015	0.0006
28	140	5.5118	139.982	5.5111	139.997	5.5117	140.015	5.5124	0.015	0.0006
30	150	5.9055	149.982	5.9048	149.997	5.9054	150.015	5.9061	0.015	0.0006

FITTING PRACTICES - continued

HOUSING FITS RADIAL BALL BEARING

Housing fits, ABEC 1, ABEC 3

Note: These tables are to be used for applications where only one ring (either inner or outer) has an interference fit with its shaft and housing. The guidelines for operating conditions covering these tables are found on page A123. In cases where interference fits are used for both rings, bearings with a special internal clearance may be required. Housing bore diameter dimensions are for steel materials. Consult your Timken representative when using other housing materials.

HOUSING FITS, ABEC 1, ABEC 3																
Basic Bearing Number					These diameters result in a bearing O.D. to housing bore fit which closely conforms to H6 listed on pages A66 and A72						These diameters result in a bearing O.D. to housing bore fit which closely conforms to M7 listed on pages A66 and A72					
					Housing Stationary, Load Stationary or Housing Rotating, Load Rotating				Mean Fit Loose		Housing Rotating, Load Stationary or Housing Stationary, Load Rotating					
Extra Small	Extra Light	Light	Medium	Heavy	Housing Bore		Mean Fit Loose		Housing Bore		Mean Fit Tight					
					Min.	Max	ABEC 1	ABEC 3	Min.	Max.	ABEC 1	ABEC 3				
					mm	in.	mm	in.	mm	in.	mm	in.	mm	in.		
30, S, F	9100, 9300	200, 5200, 7200	300, 5300, 7300	400 <sup>(2)</sup> 7400												
SERIES	SERIES	SERIES	SERIES	SERIES												
33K3, F33K3	—	—	—	—	9.525	0.3750	9.535	0.3754	0.010	0.00040	0.009	0.00035	9.507	0.3743		
33K4	—	—	—	—	12.700	0.5000	12.710	0.5004	0.010	0.00040	0.009	0.00035	12.682	0.4993		
33K5, F33K5	—	—	—	—	12.700	0.5000	12.710	0.5004	0.010	0.00040	0.009	0.00035	12.682	0.4993		
34K	—	—	—	—	15.999	0.6299	16.010	0.6303	0.010	0.00040	0.009	0.00035	15.982	0.6292		
35K	—	—	—	—	18.999	0.7480	19.012	0.7485	0.011	0.00045	0.010	0.00040	18.979	0.7472		
36K	—	—	—	—	18.999	0.7480	19.012	0.7485	0.011	0.00045	0.010	0.00040	18.979	0.7472		
37K	—	—	—	—	21.999	0.8661	22.012	0.8666	0.011	0.00045	0.010	0.00040	21.979	0.8653		
38K	—	—	—	—	21.999	0.8661	22.012	0.8666	0.011	0.00045	0.010	0.00040	21.979	0.8653		
38KV	—	—	—	—	24.000	0.9449	24.013	0.9454	0.011	0.00045	0.010	0.00040	23.980	0.9441		
39K	9100	—	—	—	25.999	1.0236	26.012	1.0241	0.011	0.00045	0.010	0.00040	25.979	1.0228		
S1K7, FS1K7	—	—	—	—	15.875	0.6250	15.885	0.6254	0.010	0.00040	0.009	0.00035	15.857	0.6243		
S1K	—	—	—	—	19.050	0.7500	19.063	0.7505	0.011	0.00045	0.010	0.00040	19.030	0.7492		
S3K, FS3K	—	—	—	—	22.225	0.8750	22.238	0.8755	0.011	0.00045	0.010	0.00040	22.205	0.8742		
S5K	—	—	—	—	28.575	1.1250	28.588	1.1255	0.011	0.00045	0.010	0.00040	28.555	1.1242		
S7K	—	—	—	—	34.925	1.3750	34.940	1.3756	0.014	0.00055	0.011	0.00045	34.900	1.3740		
S8K	—	—	—	—	41.275	1.6250	41.290	1.6256	0.014	0.00055	0.011	0.00045	41.250	1.6240		
S9K	—	—	—	—	47.625	1.8750	47.640	1.8756	0.014	0.00055	0.011	0.00045	47.600	1.8740		
S10K	—	—	—	—	50.800	2.0000	50.818	2.0007	0.015	0.00060	0.014	0.00055	50.770	1.9988		
S11K	—	—	—	—	53.975	2.1250	53.993	2.1257	0.015	0.00060	0.014	0.00055	53.945	2.1238		
S12K	—	—	—	—	57.150	2.2500	57.168	2.2507	0.015	0.00060	0.014	0.00055	57.120	2.2488		
F2002	—	—	—	—	9.525	0.3750	9.533	0.3753	0.000	0.00000	0.000	0.00000	9.522	0.3749		
F2	—	—	—	—	11.112	0.4375	11.120	0.4378	0.000	0.00000	0.000	0.00000	11.110	0.4374		
F3	—	—	—	—	14.285	0.5624	14.295	0.5628	0.000	0.00000	0.000	0.00000	14.285	0.5624		
F4	—	—	—	—	15.872	0.6249	15.883	0.6253	0.000	0.00000	0.000	0.00000	15.872	0.6249		
F5	—	—	—	—	17.460	0.6874	17.470	0.6878	0.000	0.00000	0.000	0.00000	17.460	0.6874		
—	9101, 9302	—	—	—	28.001	1.1024	28.014	1.1029	0.011	0.00045	0.000	0.00040	27.981	1.1016		
—	9303	200	—	—	30.000	1.1811	30.013	1.1816	0.011	0.00045	0.010	0.00040	29.980	1.1803		
—	9102	201	—	—	31.999	1.2598	32.014	1.2604	0.014	0.00055	0.011	0.00045	31.974	1.2588		
—	9103	202	300	—	35.001	1.3780	35.016	1.3786	0.014	0.00055	0.011	0.00045	34.976	1.3770		
—	9304	—	301	—	37.000	1.4567	37.015	1.4573	0.014	0.00055	0.011	0.00045	36.975	1.4557		
—	—	203	—	—	40.000	1.5748	40.015	1.5754	0.014	0.00055	0.011	0.00045	39.975	1.5738		
—	9104, 9305	—	302	—	41.999	1.6535	42.014	1.6541	0.014	0.00055	0.011	0.00045	41.974	1.6525		
—	9105, 9306	204	303	—	47.000	1.8504	47.015	1.8510	0.014	0.00055	0.011	0.00045	46.975	1.8494		
—	—	205	304	—	51.999	2.0472	52.017	2.0479	0.015	0.00060	0.014	0.00055	51.968	2.0460		
—	9106, 9307	—	—	—	55.001	2.1654	55.019	2.1661	0.015	0.00060	0.014	0.00055	54.971	2.1642		
—	9107, 9308	206	305	403	61.999	2.4409	62.017	2.4416	0.015	0.00060	0.014	0.00055	61.968	2.4397		
—	9108	—	—	—	68.001	2.6772	68.019	2.6779	0.015	0.00060	0.014	0.00055	67.970	2.6760		
—	9310	207	306	404	71.999	2.8346	72.017	2.8353	0.015	0.00060	0.014	0.00055	71.968	2.8334		
—	9109	—	—	—	75.001	2.9528	75.019	2.9535	0.015	0.00060	0.014	0.00055	74.971	2.9516		
—	9110	208	307	405	80.000	3.1496	80.018	3.1503	0.015	0.00060	0.014	0.00055	79.969	3.1484		
—	9312	209	—	—	85.001	3.3465	85.024	3.3474	0.019	0.00080	0.017	0.00065	84.966	3.3451		
—	9111	210	308	406	90.000	3.5433	90.023	3.5442	0.019	0.00080	0.017	0.00065	89.964	3.5419		
—	9112	—	—	—	95.001	3.7402	95.019	3.7411	0.019	0.00080	0.017	0.00065	94.965	3.7388		
—	9113	211	309	407	100.000	3.9370	100.023	3.9379	0.019	0.00080	0.017	0.00065	99.964	3.9356		
—	9114	212	310	408	110.000	4.3307	110.023	4.3316	0.019	0.00080	0.017	0.00065	109.964	4.3293		

<sup>(2)</sup>400 Series are "specials," consult your Timken representative.

FITTING PRACTICES - continued

HOUSING FITS, ABEC 1, ABEC 3

Note: These tables are to be used for applications where only one ring (either inner or outer) has an interference fit with its shaft and housing. The guidelines for operating conditions covering these tables are found on page A123. In cases where interference fits are used for both rings, bearings with a special internal clearance may be required. Housing bore diameter dimensions are for steel materials. Consult your Timken representative when using other housing materials.

HOUSING FITS, ABEC 1, ABEC 3																					
Basic Bearing Number					These diameters result in a bearing O.D. to housing bore fit which closely conforms to H6 beginning on A61								These diameters result in a bearing O.D. to housing bore fit which closely conforms to M7 listed on page A63								
					Housing Stationary, Load Stationary or Housing Rotating, Load Rotating				Mean Fit Loose				Housing Rotating, Load Stationary or Housing Stationary, Load Rotating				Mean Fit Tight				
Extra Small	Extra Light	Light	Medium	Heavy	Housing Bore		Max		ABEC 1		ABEC 3		Housing Bore		Max.		ABEC 1		ABEC 3		
					mm	in.	mm	in.	mm	in.	mm	in.	mm	in.	mm	in.	mm	in.	mm	in.	
<b>30,S,F</b>	<b>9100,</b>	<b>200,5200,</b>	<b>300,5300,</b>	<b>400,5400,</b>																	
<b>SERIES</b>	<b>SERIES</b>	<b>SERIES</b>	<b>SERIES</b>	<b>SERIES</b>																	
—	9115	—	—	—	115.001	4.5276	115.024	4.5285	0.019	0.0008	0.017	0.00065	114.965	4.5262	115.001	4.5276	0.010	0.0004	0.013	0.00050	
—	—	213	311	409	120.000	4.7244	120.023	4.7253	0.019	0.0008	0.017	0.00065	119.964	4.7230	120.000	4.7244	0.010	0.0004	0.013	0.00050	
—	—	214	—	—	125.001	4.9213	125.026	4.9223	0.023	0.0009	0.019	0.00075	124.960	4.9197	125.001	4.9213	0.010	0.0004	0.014	0.00055	
—	9117	215	312	410	130.000	5.1181	130.025	5.1191	0.023	0.0009	0.019	0.00075	129.959	5.1165	130.000	5.1181	0.010	0.0004	0.014	0.00055	
—	9118	216	313	411	140.000	5.5118	140.025	5.5128	0.023	0.0009	0.019	0.00075	139.959	5.5102	140.000	5.5118	0.010	0.0004	0.014	0.00055	
—	9120	217	314	412	150.000	5.9055	150.025	5.9065	0.023	0.0009	0.019	0.00075	149.959	5.9039	150.000	5.9055	0.010	0.0004	0.014	0.00055	
—	120-2	218	315	—	160.000	6.2992	160.025	6.3002	0.025	0.0010	0.020	0.00080	159.959	6.2976	160.000	6.2992	0.008	0.0003	0.013	0.00050	
—	9121	—	—	413	160.000	6.2992	160.025	6.3002	0.025	0.0010	0.020	0.00080	159.959	6.2976	160.000	6.2992	0.008	0.0003	0.013	0.00050	
—	9122	129	316	—	170.000	6.6929	170.025	6.6939	0.025	0.0010	0.020	0.00080	169.959	6.6913	170.000	6.6929	0.008	0.0003	0.013	0.00050	
—	122	—	—	—	175.000	6.8898	175.026	6.8908	0.025	0.0010	0.020	0.00080	174.960	6.8882	175.001	6.8898	0.008	0.0003	0.013	0.00050	
—	9124	220	317	414	180.000	7.0866	180.025	7.0876	0.025	0.0010	0.020	0.00080	179.959	7.0850	180.000	7.0866	0.008	0.0003	0.013	0.00050	
—	124	221	318	415	190.000	7.4803	190.028	7.4815	0.029	0.0012	0.023	0.00090	189.954	7.4785	190.000	7.4803	0.008	0.0003	0.014	0.00055	
—	9126	222	319	416	200.000	7.8740	200.028	7.8752	0.029	0.0012	0.023	0.00090	199.954	7.8722	200.000	7.8740	0.008	0.0003	0.014	0.00055	
—	126	—	—	—	205.001	8.0709	205.029	8.0721	0.029	0.0012	0.023	0.00090	204.955	8.0691	205.001	8.0709	0.008	0.0003	0.014	0.00055	
—	9128	—	—	—	210.000	8.2677	210.028	8.2689	0.029	0.0012	0.023	0.00090	209.954	8.2659	210.000	8.2677	0.008	0.0003	0.014	0.00055	
—	—	224	320	—	215.001	8.4646	215.029	8.4658	0.029	0.0012	0.023	0.00090	214.955	8.4628	215.001	8.4646	0.008	0.0003	0.014	0.00055	
—	128	—	—	—	220.000	8.6614	220.028	8.6626	0.029	0.0012	0.023	0.00090	219.954	8.6596	220.000	8.6614	0.008	0.0003	0.014	0.00055	
—	9130	—	321	418	225.001	8.8583	225.029	8.8595	0.029	0.0012	0.023	0.00090	224.955	8.8565	225.001	8.8583	0.008	0.0003	0.014	0.00055	
—	—	226	—	—	230.000	9.0551	230.027	9.0563	0.029	0.0012	0.023	0.00090	229.954	9.0533	230.000	9.0551	0.008	0.0003	0.014	0.00055	
—	130	—	—	—	235.001	9.2520	235.029	9.2532	0.029	0.0012	0.023	0.00090	234.955	9.2502	235.001	9.2520	0.008	0.0003	0.014	0.00055	
—	9132	—	322	—	240.000	9.4488	240.027	9.4506	0.029	0.0012	0.023	0.00090	239.954	9.4470	240.000	9.4488	0.008	0.0003	0.014	0.00055	
—	132	228	—	—	250.000	9.8425	250.027	9.8437	0.029	0.0012	0.023	0.00090	249.954	9.8407	250.000	9.8425	0.008	0.0003	0.014	0.00055	
—	9134	—	324	—	259.999	10.2362	260.032	10.2374	0.033	0.0013	0.027	0.00105	259.942	10.2342	259.999	10.2362	0.008	0.0003	0.015	0.00060	
—	134	—	—	420	265.001	10.4331	265.034	10.4343	0.033	0.0013	0.027	0.00105	264.950	10.4311	265.001	10.4331	0.008	0.0003	0.015	0.00060	
—	—	230	—	—	269.999	10.6299	270.032	10.6311	0.033	0.0013	0.027	0.00105	269.949	10.6279	269.999	10.6299	0.008	0.0003	0.015	0.00060	
—	136,9136	—	326	—	279.999	11.0236	280.032	11.0248	0.033	0.0013	0.027	0.00105	279.949	11.0216	279.999	11.0236	0.008	0.0003	0.015	0.00060	
—	9138	232	—	—	289.999	11.4173	290.039	11.4185	0.033	0.0013	0.027	0.00105	289.949	11.4153	289.999	11.4173	0.008	0.0003	0.015	0.00060	
—	138	—	328	—	299.999	11.8110	300.032	11.8122	0.033	0.0013	0.027	0.00105	299.949	11.8090	299.999	11.8110	0.008	0.0003	0.015	0.00060	
—	9140	234	—	—	309.999	12.2047	310.029	12.2059	0.033	0.0013	—	—	309.949	12.2027	309.999	12.2047	0.008	0.0003	—	—	
—	—	236	330	—	319.999	12.5984	320.035	12.5998	0.038	0.0015	—	—	319.943	12.5962	319.999	12.5984	0.008	0.0003	—	—	
—	9144	238	—	—	339.999	13.3858	340.035	13.3872	0.038	0.0015	—	—	339.943	13.3836	339.999	13.3858	0.008	0.0003	—	—	
—	9146	240	—	—	359.999	14.1732	360.035	14.1746	0.038	0.0015	—	—	359.943	14.1710	359.999	14.1732	0.008	0.0003	—	—	
—	—	242	336	—	380.007	14.9606	380.035	14.9620	0.038	0.0015	—	—	379.943	14.9584	379.999	14.9606	0.008	0.0003	—	—	
—	9152	244	338	—	399.999	15.7480	400.035	15.7494	0.038	0.0015	—	—	399.943	15.7458	399.999	15.7480	0.008	0.0003	—	—	
—	9156	246	340	—	419.999	16.5354	420.040	16.5370	0.038	0.0017	—	—	419.936	16.5329	419.999	16.5354	0.010	0.0004	—	—	
—	—	248	342	—	439.999	17.3228	440.040	17.3244	0.038	0.0017	—	—	439.936	17.3203	439.999	17.3228	0.010	0.0004	—	—	
—	9160	250	344	—	459.999	18.1102	460.040	18.1118	0.038	0.0017	—	—	459.936	18.1077	459.999	18.1102	0.010	0.0004	—	—	
—	9164	252	—	—	479.999	18.8976	480.040	18.8992	0.038	0.0017	—	—	479.936	18.8951	479.999	18.8976	0.010	0.0004	—	—	
—	—	256	348	—	499.999	19.6850	500.040	19.6866	0.038	0.0017	—	—	499.936	19.6825	499.999	19.6850	0.010	0.0004	—	—	
—	—	260	352	—	539.999	21.2598	540.042	21.2615	0.048	0.0019	—	—	539.930	21.2571	539.999	21.2598	0.010	0.0004	—	—	
—	—	264	356	—	579.999	22.8346	580.042	22.8363	0.048	0.0019	—	—	579.930	22.8319	579.999	22.8346	0.010	0.0004	—	—	
—	9180	—	—	—	599.999	23.6220	600.042	23.6237	0.048	0.0019	—	—	599.930	23.6193	599.999	23.6220	0.010	0.0004	—	—	

FITTING PRACTICES - continued

SHAFT AND HOUSING SHOULDERS

Shaft and housing shoulder diameters for radial roller and thrust ball and roller bearings are also found in the respective dimension tables. Shaft and housing shoulders for ball bearings are shown below.

RADIAL BALL BEARINGS

The preferred method of locating bearings on shafts and in housings is to provide accurate shoulders perpendicular to the shaft axis. Shoulders should be large enough to exceed the theoretical point of tangency between the corner radius and the face of the bearing, and small enough to permit bearing removal with proper pullers.

These tables give the suggested maximum and minimum shaft and housing shoulder diameters for the majority of applications. Where design limitations do not permit conformance to these suggested diameters, your Timken representative should be consulted.

Suggested shaft and housing fillet radii are listed in the dimensional tables of each product catalog and must be used to assure proper seating against shaft and housing shoulders.

Shaft and housing diameters for radial ball bearings are shown below and on the following two pages. For radial cylindrical, spherical and tapered roller bearings, refer to the respective dimension tables. Housing shoulders for wide inner ring bearings are shown on page A133.

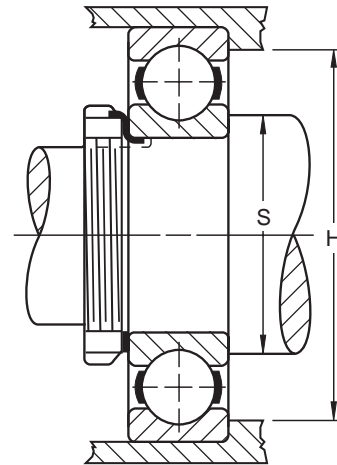

EXTRA-LIGHT 9300 SERIES				
Basic Bearing Number	Shaft Shoulder		Housing Shoulder	
	$\pm 0.25$ mm $\pm .010$ "		$\pm 0.25$ mm $\pm .010$ "	
	mm	in.	mm	in.
9301K	14.7	0.58	21.6	0.85
9302K	17.8	0.70	25.4	1.00
9303K	19.8	0.78	27.4	1.08
9304K	23.9	0.94	33.5	1.32
9305K	29.0	1.14	38.6	1.52
9306K	33.5	1.32	43.4	1.71
9307K	39.6	1.56	50.8	2.00
9308K	45.0	1.77	57.4	2.26
9309K	50.3	1.98	63.2	2.49
9310K	54.9	2.16	67.6	2.66
9311K	61.0	2.40	74.7	2.94
9312K	65.8	2.59	79.8	3.14

EXTRA-SMALL SERIES								
Basic Bearing Number	Shoulder Diameters							
	Shaft, S				Housing, H			
	Max.		Min.		Max.		Min.	
	mm	in.	mm	in.	mm	in.	mm	in.
33K3	5.1	0.20	4.8	0.19	8.1	0.32	7.9	0.31
33K4	6.1	0.24	5.8	0.23	11.2	0.44	10.9	0.43
33K5	6.6	0.26	6.4	0.25	11.2	0.44	10.9	0.43
34K	6.6	0.26	6.4	0.25	14.2	0.56	14.0	0.55
35K	9.4	0.37	9.1	0.36	17.0	0.67	16.8	0.66
36K	9.4	0.37	9.1	0.36	17.0	0.67	16.8	0.66
37K	11.2	0.44	10.7	0.42	20.1	0.79	19.6	0.77
38K	11.4	0.45	10.9	0.43	20.1	0.79	19.6	0.77
38KV	11.4	0.45	10.9	0.43	20.1	0.79	19.6	0.77
39K	13.0	0.51	12.5	0.49	23.1	0.91	22.6	0.89
S1K7	8.6	0.34	8.1	0.32	14.2	0.56	13.7	0.54
S1K	9.4	0.37	8.9	0.35	17.5	0.69	17.0	0.67
S3K	12.7	0.50	12.2	0.48	20.3	0.80	19.8	0.78
S5K	16.0	0.63	15.5	0.61	25.1	0.99	24.6	0.97
S7K	21.3	0.84	20.3	0.80	31.5	1.24	30.5	1.20
S8K	24.6	0.97	23.6	0.93	37.1	1.46	35.6	1.40
S9K	28.9	1.14	27.9	1.10	41.9	1.65	40.9	1.61
S10K	31.5	1.24	30.5	1.20	46.7	1.84	45.7	1.80
S11K	34.0	1.34	33.0	1.30	49.5	1.95	48.5	1.91
S12K	39.4	1.55	38.4	1.51	55.9	2.20	50.8	2.00

FITTING PRACTICES - continued

SHAFT AND HOUSING SHOULDERS  
RADIAL BALL BEARINGS

RADIAL BALL BEARINGS																											
Basic Bearing Number		Extra-Light • 9100 Series Shoulder Diameters								Light • 200, 5200, 7200WN Series Shoulder Diameters								Medium • 300, 5300, 7300WN Series Shoulder Diameters									
		Shaft, S				Housing, H				Shaft, S				Housing, H				Shaft, S				Housing, H					
		Max.	Min.	Max.	Min.	Max.	Min.	Max.	Min.	Max.	Min.	Max.	Min.	Max.	Min.	Max.	Min.	Max.	Min.	Max.	Min.						
		mm	in.	mm	in.	mm	in.	mm	in.	mm	in.	mm	in.	mm	in.	mm	in.	mm	in.	mm	in.						
9100	13.2	0.52	11.9	0.47	24.1	0.95	23.1	0.91	200	14.2	0.56	12.7	0.50	24.9	0.98	24.6	0.97	300	15.0	0.59	12.7	0.50	30.0	1.18	29.2	1.15	
9101	18.0	0.71	14.0	0.55	25.9	1.02	24.6	0.97	201	16.3	0.64	14.7	0.58	26.9	1.06	26.7	1.05	301	17.5	0.69	16.0	0.63	31.0	1.22	30.7	1.21	
9102	19.0	0.75	17.0	0.67	30.0	1.18	28.7	1.13	202	19.0	0.75	17.5	0.69	30.0	1.18	29.2	1.15	302	20.6	0.81	19.0	0.75	36.1	1.42	35.6	1.40	
9103	20.6	0.81	19.0	0.75	33.0	1.30	31.8	1.25	203	21.3	0.84	19.6	0.77	34.0	1.34	33.3	1.31	303	23.1	0.91	21.1	0.83	40.9	1.61	40.6	1.60	
9104	24.9	0.98	22.6	0.89	37.1	1.46	35.8	1.41	204	25.4	1.00	23.9	0.94	40.9	1.61	40.1	1.58	304	26.9	1.06	23.9	0.94	45.0	1.77	44.4	1.75	
9105	30.0	1.18	27.4	1.08	41.9	1.65	40.6	1.60	205	31.0	1.22	29.0	1.14	46.0	1.81	45.2	1.78	305	33.3	1.31	29.0	1.14	55.1	2.17	53.1	2.09	
9106	35.1	1.38	34.0	1.34	49.0	1.93	47.8	1.88	206	37.3	1.47	34.0	1.34	56.1	2.21	54.9	2.16	306	39.6	1.56	34.0	1.34	65.0	2.56	62.0	2.44	
9107	41.4	1.63	38.9	1.53	56.1	2.21	54.6	2.15	207	43.7	1.72	38.9	1.53	65.0	2.56	62.7	2.47	307	45.2	1.78	42.9	1.69	71.1	2.80	69.1	2.72	
9108	46.0	1.81	43.9	1.73	62.0	2.44	60.7	2.39	208	49.3	1.94	43.9	1.73	72.9	2.87	70.6	2.78	308	50.8	2.00	49.0	1.93	81.0	3.19	77.7	3.06	
9109	51.6	2.03	49.3	1.94	69.1	2.72	67.8	2.67	209	54.1	2.13	49.3	1.94	78.0	3.07	75.4	2.97	309	2.28	57.9	2.13	54.1	3.58	90.9	3.41	86.6	86.6
9110	56.4	2.22	54.1	2.13	73.9	2.91	72.6	2.86	210	59.4	2.34	54.1	2.13	83.1	3.27	80.5	3.17	310	63.5	2.50	59.9	2.36	100.1	3.94	95.2	3.75	
9111	63.0	2.48	59.2	2.33	83.1	3.27	81.8	3.22	211	64.5	2.54	61.2	2.41	93.5	3.68	90.4	3.56	311	69.8	2.75	65.0	2.56	110.0	4.33	104.9	4.13	
9112	67.8	2.67	64.3	2.53	88.1	3.47	86.9	3.42	212	71.4	2.81	67.8	2.67	101.1	3.98	98.3	3.87	312	74.7	2.94	72.1	2.84	118.1	4.65	112.8	4.44	
9113	72.1	2.84	69.1	2.72	93.0	3.66	91.7	3.61	213	77.0	3.03	72.6	2.86	111.0	4.37	106.4	4.19	313	81.0	3.19	77.0	3.03	128.0	5.04	122.2	4.81	
9114	79.0	3.11	73.9	2.91	103.1	4.06	100.8	3.97	214	81.8	3.22	77.7	3.06	116.1	4.57	112.0	4.41	314	87.4	3.44	82.0	3.23	137.9	5.43	130.3	5.13	
9115	84.1	3.31	79.0	3.11	108.0	4.25	105.7	4.16	215	87.4	3.44	82.6	3.25	120.9	4.76	116.6	4.59	315	98.6	3.88	87.1	3.43	148.1	5.83	139.7	5.50	
9116	90.4	3.56	84.1	3.31	118.1	4.65	114.3	4.50	216	93.7	3.69	90.2	3.55	130.0	5.12	125.2	4.93	316	100.1	3.94	91.9	3.62	158.0	6.22	149.4	5.88	
9117	95.2	3.75	88.9	3.50	122.9	4.84	119.6	4.71	217	98.6	3.88	95.2	3.75	140.0	5.51	134.9	5.31	317	104.9	4.13	99.1	3.90	166.1	6.54	157.2	6.19	
9118	102.4	4.03	97.5	3.84	131.1	5.16	130.3	5.13	218	105.7	4.16	100.1	3.94	150.1	5.91	142.7	5.62	318	111.3	4.38	103.9	4.09	176.0	6.93	165.1	6.50	
9120	111.3	4.38	107.4	4.23	141.0	5.55	138.2	5.44	219	111.3	4.38	106.9	4.21	158.0	6.22	153.9	6.06	319	117.6	4.63	109.0	4.29	185.9	7.32	174.8	6.88	
9121	118.4	4.66	115.1	4.53	150.1	5.91	146.0	5.75	220	117.6	4.63	112.0	4.41	167.9	6.61	160.3	6.31	320	124.0	4.88	114.0	4.49	200.9	7.91	187.4	7.38	
9122	124.7	4.91	119.9	4.72	160.0	6.30	157.0	6.18	221	124.0	4.88	117.1	4.61	178.1	7.01	174.8	6.88	321	130.3	5.13	119.1	4.69	211.1	8.31	196.8	7.75	
9124	134.1	5.28	130.0	5.12	169.9	6.69	165.1	6.50	222	130.3	5.13	121.9	4.80	188.0	7.40	179.3	7.06	322	139.7	5.50	124.0	4.88	226.1	8.90	209.6	8.25	
9126	147.6	5.81	140.0	5.51	190.0	7.48	184.1	7.25	224	143.0	5.63	132.1	5.20	202.9	7.99	192.0	7.56	324	152.4	6.00	134.1	5.28	246.1	9.69	226.8	8.93	
9128	153.9	6.06	147.6	5.81	200.2	7.88	195.1	7.68	226	152.4	6.00	144.0	5.67	215.9	8.50	206.5	8.13	326	163.6	6.44	148.1	5.83	262.1	10.32	246.1	9.69	
9130	167.4	6.59	162.1	6.38	213.1	8.39	206.5	8.13	228	165.1	6.50	153.9	6.06	236.0	9.29	223.8	8.81	328	176.0	6.93	158.0	6.22	281.9	11.10	263.7	10.38	
9132	176.8	6.96	166.6	6.56	228.6	9.00	222.2	8.75	230	177.0	6.97	164.1	6.46	256.0	10.08	241.3	9.50	330	189.0	7.44	167.9	6.61	302.0	11.89	280.9	11.06	
9134	192.0	7.56	182.1	7.17	247.9	9.76	239.8	9.44	232	186.9	7.36	174.0	6.85	276.1	10.87	260.4	10.25	332	188.0	7.84	178.0	7.01	322.1	12.68	294.1	11.58	
9138	212.9	8.38	201.9	7.95	278.1	10.95	266.7	10.50	234	202.7	7.98	188.0	7.40	292.1	11.50	276.4	10.88	334	213.4	8.40	188.0	7.40	342.1	13.47	311.7	12.27	
9140	224.5	8.84	212.1	8.35	297.9	11.73	285.0	11.22	236	212.9	8.38	198.1	7.80	302.0	11.89	281.7	11.09	336	223.5	8.80	198.1	7.80	362.0	14.25	331.5	13.05	
9144	246.4	9.70	233.9	9.21	326.1	12.84	310.9	12.24	238	222.8	8.77	208.0	8.19	322.1	12.68	301.8	11.88	338	237.5	9.35	212.1	8.35	378.2	14.89	345.2	13.59	
9148	266.7	10.50	254.0	10.00	345.9	13.62	330.7	13.02	240	239.3	9.42	217.9	8.58	342.1	13.47	319.3	12.57	340	249.9	9.84	222.0	8.74	398.0	15.67	365.0	14.37	
9152	291.8	11.49	278.1	10.95	382.0	15.04	366.8	14.44	242	246.1	9.69	225.3	8.87	362.2	14.26	336.8	13.26	342	260.1	10.24	232.2	9.14	418.3	16.47	385.3	15.17	
9156	313.2	12.33	297.9	11.73	402.1	15.83	386.8	15.23	244	257.6	10.14	238.0	9.37	382.0	15.04	356.6	14.04	344	272.5	10.73	242.1	9.53	437.9	17.24	405.4	15.96	
9160	339.3	13.36	318.0	12.52	442.0	17.40	421.6	16.60	246	268.7	10.58	247.9	9.76	402.1	15.83	370.8	14.60	348	292.6	11.52	262.1	10.32	478.0	18.82	439.9	17.32	
9164	360.4	14.19	338.1	13.31	462.0	18.19	441.7	17.39	248	283.5	11.16	258.1	10.16	421.9	16.61	385.6	15.18	352	318.5	12.54	288.0	11.34	512.1	20.16	474.0	18.66	
9180	457.2	18.00	431.8	17.00	561.8	22.12	549.1	21.62	250	293.4	11.55	268.0	10.55	442.0	17.40	398.8	15.70	356	341.1	13.43	308.1	12.13	551.9	21.73	511.3	20.13	

FITTING PRACTICES - continued

SHAFT AND HOUSING SHOULDERS  
RADIAL BALL BEARINGS

HEAVY • 400, 7400 SERIES

Basic Bearing Number	Shoulder Diameters							
	Shaft, S				Housing, H			
	Max.		Min.		Max.		Min.	
	mm	in.	mm	in.	mm	in.	mm	in.
7405	37.3	1.47	34.0	1.34	71.1	2.80	66.8	2.63
7406	43.7	1.72	39.1	1.54	81.0	3.19	76.2	3.00
7407	49.0	1.93	43.9	1.73	90.9	3.58	85.9	3.38
7408	55.6	2.19	50.0	1.97	100.1	3.94	93.7	3.69
7409	62.0	2.44	55.1	2.17	110.0	4.33	101.6	4.00
7410	68.3	2.69	62.0	2.44	118.1	4.65	111.3	4.38
7411	74.4	2.93	67.1	2.64	128.0	5.04	120.7	4.75
7412	81.0	3.19	72.1	2.84	137.9	5.43	130.3	5.13
7413	88.9	3.50	77.0	3.03	148.1	5.83	139.7	5.50
7414	93.7	3.69	84.1	3.31	166.1	6.54	155.7	6.13
7415	99.8	3.93	88.9	3.50	176.0	6.93	163.6	6.44
7416	104.9	4.13	94.0	3.70	185.9	7.32	173.0	6.81
7418	119.1	4.69	108.0	4.25	207.0	8.15	196.9	7.75
7420	131.3	5.17	119.9	4.72	233.9	9.21	223.3	8.79

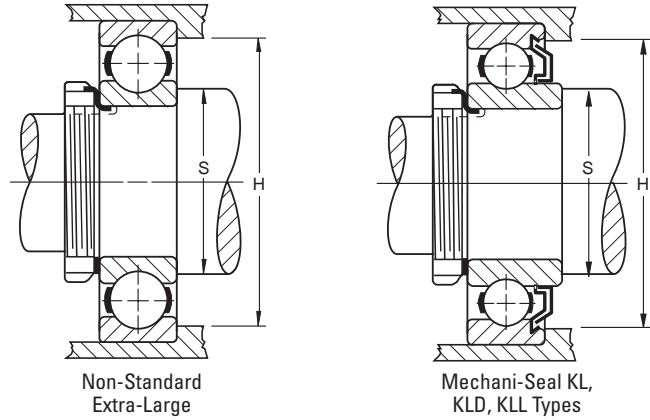

Housing shoulder diameters of bearings with Mechani-Seals differ slightly from those of other types to allow for clearance between the external rotating member of the seal and the housing shoulder.

NON-STANDARD EXTRA-LARGE

Basic Bearing Number	Shoulder Diameters							
	Shaft, S				Housing, H			
	Max.		Min.		Max.		Min.	
	mm	in.	mm	in.	mm	in.	mm	in.
120W2	117.6	4.63	111.8	4.40	150.1	5.91	146.0	5.75
122W	124.7	4.91	120.1	4.73	162.8	6.41	158.8	6.25
124W	134.1	5.28	130.0	5.12	178.1	7.01	174.5	6.87
126W	147.8	5.82	139.7	5.50	193.0	7.60	185.7	7.31
128W	157.2	6.19	150.1	5.91	207.8	8.18	202.2	7.96
130W	167.4	6.59	162.1	6.38	223.0	8.78	216.2	8.51
132W	189.0	7.44	174.0	6.85	234.7	9.24	223.8	8.81
134W	191.0	7.52	185.2	7.29	249.7	9.83	244.1	9.61
136W	203.2	8.00	195.3	7.69	264.7	10.42	257.8	10.15
138W	214.4	8.44	205.2	8.08	284.7	11.21	276.1	10.87
224W	143.0	5.63	132.1	5.20	203.2	8.00	192.0	7.56
226	152.4	6.00	144.0	5.67	215.9	8.50	206.5	8.13
228	165.1	6.50	153.9	6.06	236.0	9.29	223.8	8.81
276-2	401.8	15.82	400.1	15.75	463.6	18.25	461.5	18.17

MECHANI-SEAL KL, KLD, KLL TYPES

Basic Bearing Number	Housing Shoulder Diameter, H			
	Max.		Min.	
	mm	in.	mm	in.
36	17.0	0.67	16.8	0.66
36V	17.0	0.67	16.8	0.66
37	20.1	0.79	19.6	0.77
37V	20.1	0.79	19.6	0.77
34	20.1	0.79	19.6	0.77
38V	20.1	0.79	19.6	0.77
39	23.1	0.91	22.6	0.89
39V	23.1	0.91	22.6	0.89
200	27.7	1.09	26.2	1.03
201	29.5	1.16	27.7	1.09
20-2	29.5	1.16	27.7	1.09
201-3	29.5	1.16	27.7	1.09
202	32.5	1.28	31.0	1.22
202-2	32.5	1.28	31.0	1.22
202-3	32.5	1.28	31.0	1.22
202-4	32.5	1.28	31.0	1.22
203	36.6	1.44	35.8	1.41
204	43.7	1.72	41.1	1.62
204-2	43.7	1.72	41.1	1.62
205	48.5	1.91	46.7	1.84
205-2	48.5	1.91	46.7	1.84
206	57.9	2.28	56.4	2.22
207	67.6	2.66	64.3	2.53
208	75.4	2.97	71.4	2.81
209	80.3	3.16	77.0	3.03
209-2	80.3	3.16	77.0	3.03
211	93.7	3.69	90.4	3.56

FITTING PRACTICES - continued

WIDE INNER RING BALL BEARINGS

When shafts are selected for use with wide inner ring bearings, a minimum slip fit is very desirable for the most satisfactory mounting. Special shaft limits are required in certain cases, and a variety of standard fits can be used, including a press fit. The suggested figures are noted below. In some applications, it may be permissible to use increased shaft tolerances. In such cases, applications should be forwarded to your Timken representative for complete suggestions.

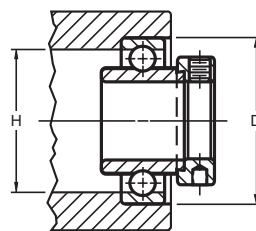

Bearing bore tolerance:

1/2" - 2 3/16" = nominal to +.013 mm +.0005";  
 2 1/4" - 3 3/16" = nominal to +.015 mm +.0006";  
 3 7/16" - 3 15/16" = nominal to +.018 mm +.0007";

Shaft tolerances:

1/2" - 1 15/16" = nominal to -.013 mm -.0005";  
 2" - 3 15/16" = nominal to -.025 mm -.0010";

HOUSING, SHOULDERS AND SHAFT DIAMETERS

KRR Type	BEARING NUMBER				Shaft Size mm in.	Basic Outer Ring Size	House Stationary <sup>(1)</sup>			Shoulder Diameter H	
	G-KRR Type	RA-RR Type	GRA-RR Type	GYA-RR* Type			Housing Bore, D Min. mm in.	Max. mm in.	Mean Fit Loose mm in.	Max. mm in.	Min. mm in.
1008KRR	—	RA008RR	GRA008RR	GYA0008RR	1/2	203	1.5748 40.000	1.5754 40.015	0.0005 0.013	1.37 34.8	1.34 34.0
—	—	RA009RR	GRA009RR	GYA009RR	9/16						
1010KRR(KR)	G1010KRR	RA010RR	GRA010RR	GYA010RR	5/8						
1011KRR	G1011KRR	—	—	—	11/16						
E17KRR	GE17KRR	RAE17RR	GRAE17RR	GYAE17RR	17						
1012KRR(KR)	G1012KRR	RA012RR	GRA012RR	GYA012RR	3/4	204	1.8504 47.000	1.8510 47.015	0.0005 0.013	1.61 40.9	1.60 40.6
E20KRR	GE20KRR	RAE20RR	GRAE20RR	GYAE20RR	20						
1013KRR	—	RA013RR	GRA013RR	GYA013RR	13/16	205	2.0472 51.999	2.0479 52.017	0.0006 0.015	1.81 46.0	1.80 45.7
1014KRR	G1014KRR	RA014RR	GRA014RR	GYA014RR	7/8						
1015KRR(KR)	G1015KRR	RA015RR	GRA015RR	GYA015RR	15/16						
1100KRR(KR)	G1100KRR	RA100RR	GRA100RR	GYA100RR	1						
E25KRR	GE25KRR	RAE25RR	GRAE25RR	GYAE25RR	25						
—	G1101KRR	RA101RR	GRA101RR	GYA101RR	1 1/16	206	2.4409 61.999	2.4416 62.017	0.0006 0.015	2.21 56.1	2.16 54.9
1102KRR(KR)	G1102KRR	RA102RR	GRA102RR	GYA102RR	1 1/8						
1103KRR(KR)	G1103KRR	RA103RR	GRA103RR	GYA103RR	1 3/16						
—	—	—	—	GYA103RR2	1 1/4						
E30KRR	GE30KRR	RAE30RR	GRAE30RR	GYAE30RR	30						
1104KRR(KR)	G1104KRR	RA104RR	GRA104RR	GYA104RR	1 1/4	207	2.8346 71.999	2.8353 72.017	0.0006 0.015	2.56 56.1	2.47 54.9
1105KRR	—	RA105RR	GRA105RR	GYA105RR	1 3/16						
1106KRR	G1106KRR	RA106RR	GRA106RR	GYA106RR	1 3/8						
1107KRR(KR)	G1107KRR	RRA107RR	GRA107RR	GYA107RR	1 7/16						
E35KRR	GE35KRR	RAE35RR	GRAE35RR	GYAE35RR	35						
1108KRR(KR)	G1108KRR	RA108RR	GRA108RR	GYA108RR	1 1/2	208	3.1496 80.000	3.1503 80.018	0.0006 0.020	2.87 78.0	2.78 75.4
—	—	RA106RR	GRA109RR	GYA109RR	1 9/16						
—	—	—	GRAE40RR	GYAE40RR	40						
1110KRR	G1110KRR	RA110RR	GRA110RR	GYA110RR	1 5/8	209	3.3465 85.001	3.3474 85.024	0.0008 0.020	3.07 78.0	2.97 75.4
1111KRR(KR)	G1111KRR	RA111RR	GRA111RR	GYA111RR	1 11/16						
1112KRR(KR)	G1112KRR	RA112RR	GRA112RR	GYA112RR	1 3/4						
E45KRR	—	—	GRAE45RR	GYAE45RR	45						
—	—	RA113RR	GRA113RR	GYA113RR	1 13/16	210	3.5433 90.000	3.5442 90.023	0.0008 0.020	3.27 83.1	3.19 81.0
1114KRR	—	RA114RR	GRA114RR	GYA114RR	1 7/8						
1115KRR(KR)	G1115KRR	RA115RR	GRA115RR	GYA115RR	1 15/16						
—	—	—	GRA115RR2	—	2						
E50KRR	GE50KRR	RAE50RR	GRAE50RR	GYAE50RR	50						
1200KRR(KR)	G1200KRR	RA200RR	GRA200RR	GYA200RR	2	211	3.9370 100.000	3.9379 100.023	0.0008 0.020	3.58 90.9	3.56 90.4
—	—	RA201RR	GRA201RR	GYA201RR	2 1/16						
1202KRR	—	RA202RR	GRA202RR	GYA202RR	2 1/8						
1203KRR(KR)	G1203KRR	RA203RR	GRA203RR	GYA203RR	2 3/16						
E55KRR	GE55KRR	RAE55RR	GRAE55RR	GYAE55RR	55						
1204KRR	—	—	—	—	2 1/4	212	4.3307 110.000	4.3316 110.02	0.0008 0.020	3.98 101.1	3.87 98.3
1207KRR(KR)	G1207KRR	—	—	—	2 7/16						
E60KRR	GE60KRR	—	—	—	60						
1215KRR	—	—	—	—	2 15/16	215	5.1181 130.000	5.1191 130.025	0.0009 0.023	4.76 120.9	4.59 116.6
E75KRR	—	—	—	—	75						

<sup>(1)</sup> When the housing revolves in relation to the shaft, housing bore dimensions shown on page A134 should be used. Outer ring tolerances and housing fillet radii correspond to equivalent 299 Series single-row radial bearings.

\* Available as non-relubricatable type (omit Prefix "G").



FITTING PRACTICES - continued

SHAFT AND HOUSING FITS  
RADIAL SPHERICAL ROLLER BEARINGS

These charts are guidelines for specifying shaft and housing fits related to particular operating conditions.

SHAFT					
Conditions	Examples	Shaft Diameter		Tolerance Symbol <sup>(1)</sup>	Remarks
Stationary inner ring load	The inner ring to be easily displaced on the shaft	Two-bearing shaft mechanism		s4	See table below for shaft size
	The inner ring not to be easily displaced on the shaft	Wheel on non-rotating shaft Tension pulleys and rope sheaves		g6 h6	
Rotating inner ring load or indeterminate load direction	Light and variable loads $P \leq 0.07C$	Electrical apparatus, machine tools, pumps, ventilators, industrial trucks	over 18 incl. 100	k6 m6	In very accurate applications k5 and m5 are used instead of k6 and m6 respectively.
	Normal and heavy loads $P > 0.07C$ $\leq 0.25C$	Applications in general, electrical motors, turbines, pumps, combustion engines, gear transmissions, woodworking machines	18 65 65 100 100 140 140 280 280 500 500 and up	m5 m6 n6 p6 r6 r7	
	Very heavy loads and shock loads $P > 0.25C$	Journal boxes for locomotives and other heavy rail vehicles, traction motors	18 65 65 100 100 140 140 200 200 500	m6 n6 p6 r6 r7	
<b>Bearings with Tapered Bore and Adapter Sleeve</b> All loads		Applications in general		All diameters	See tables for Reduction of RIC on page A76.

<sup>(1)</sup> For solid steel shaft. See tables on pages A62-A72 for numerical value.

s4 fits

A centrifugal force load produces a rotating outer ring load and a stationary inner ring load, even though the inner ring rotates. This makes it desirable to fit the outer ring tight in the housing (using a P6 fit as shown on pages A63 and A69), and the inner ring loose on the shaft using an s4 fit as listed in the table. The standard W33 bearing with oil groove and oil holes can be used.

**Note:** The s4 fit designation as referenced on this page is a special fit tolerance developed by The Timken Company for this specific application. It DOES NOT conform to ISO standards similarly published as s4 preferred shaft fits.

S4 FITS					
Data shown in thousandths of a millimeter (15=0.015 mm) or ten-thousandths of an inch (6=.0006"). See dimensional tables for nominal bore.					
Bore		Variance from Nominal Bore			
over	mm incl.	Tolerance +0	Shaft Diameter		Fit
		mm in.	mm in.	mm in.	mm in.
50	80	-15	-25	-36	10L
					36L
		-6	-10	-14	4L 14L
80	120	-20	-33	-43	13L
					43L
		-8	-13	-17	5L 17L
120	180	-25	-41	-53	15L
					53L
		-10	-16	-21	6L 21L
180	250	-30	-48	-64	18L
					64L
		-12	-19	-25	7L 25L





FITTING PRACTICES - continued

**SHAFT AND HOUSING FITS**  
**RADIAL SPHERICAL ROLLER BEARINGS**

These charts are guidelines for specifying shaft and housing fits related to particular operating conditions.

HOUSING						
Conditions		Examples	Tolerance Symbol <sup>(2)</sup>	Remarks		
One piece bearing housing	Rotating outer ring load	Variable load direction	Two-bearing eccentric shaft mechanism	P6	The outer ring is not displaceable axially	
		Heavy loads on bearings in thin walled housings	Supporting wheels in cranes, wheel hubs, crank bearings	P7		
		Normal and heavy loads	Wheel hubs, crank bearings	N7		
		Light and variable loads	Conveyor rollers, rope sheaves, tension pulleys	M7		
Split or one piece bearing housing	Indeterminate load direction	Heavy shock loads	Electrical traction motors	K7	The outer ring is, as a rule, not displaceable axially.	
		Heavy and normal loads, axial displacement of outer ring not required	Electrical motors, pumps, crankshaft main bearings			
	Stationary outer ring load	Normal and light loads, axial displacement of the outer ring desirable	Electrical motors, pumps, crankshaft main bearings	J7	The outer ring is, as a rule, displaceable axially.	
		Shock loads, temporarily complete unloading	Journal boxes for rail vehicles			
		All loads	Bearing applications in general, journal boxes for rail vehicles			H7
		Normal and light loads, loads under simple operating conditions	Line shaftings			H8
	Heat supplied through the shaft	Dryer cylinders	G7	The outer ring is easily displaced axially.		
One piece bearing housing	Applications requiring particular accuracy	Very accurate running and small deflections under variable loads	For main spindles in machine tools O.D. less than 125 mm O.D. 125 to 250 mm O.D. over 250 mm	M6 N6 P6	The outer ring is not displaceable axially.	
		Very accurate running under light loads and indeterminate load direction	Held bearings in high speed centrifugal force compressors	K6	The outer ring is, as a rule not displaceable axially.	
		Very accurate running, axial displacement of outer ring desirable	Floating bearings in high speed centrifugal force compressors	J6	The outer ring is easily displaced axially.	

<sup>(2)</sup> Cast iron or steel housing. For numerical values see tables on pages A62-A69. For housings of light metal, tolerances generally are selected which give a slightly tighter fit than those given in the table.

FITTING PRACTICES - continued

SHAFT AND HOUSING FITS  
THRUST BALL BEARINGS

TYPE TVB SHAFT				TYPE TVL AND DTVL SHAFT					
Shaft and housing diameters shown as variance from nominal dimensions. Shaft and housing data shown in millimeters over inches.									
Bearing Bore Nominal (Min.)		Shaft Diameter		Bearing Bore Nominal (Max.)		Shaft Diameter		Loose Fit**	
over	incl.	Max.	Min.	over	incl.	Interference Fit*	Min.	Max.	Min.
mm	mm	mm	mm	mm	mm	mm	mm	mm	mm
in.	in.	in.	in.	in.	in.	in.	in.	in.	in.
0.000	171.450	+0	-0.030	0.000	504.825	+0.076	+0	-0.152	-0.076
0.0000	6.7500	+0	-0.0012	0.0000	19.8750	+0.0030	+0	-0.0060	-0.0030
171.450	508.000	+0	-0.038	504.825	1524.000	+0.127	+0	-0.254	-0.127
6.7500	20.0000	+0	-0.0015	19.8750	60.0000	+0.0050	+0	-0.0100	-0.0050
HOUSING				HOUSING					
Bearing Bore Nominal (Min.)		Housing Bore		Bearing O. D. Nominal (Max.)		Shaft Diameter		Interference Fit*	
over	incl.	Max.	Min.	over	incl.	Loose Fit**	Min.	Max.	Min.
mm	mm	mm	mm	mm	mm	mm	mm	mm	mm
in.	in.	in.	in.	in.	in.	in.	in.	in.	in.
119.858	441.325	+0.229	+0.127	0.000	584.000	+0.152	0.076	-0.152	-0.076
4.7188	17.3750	+0.0090	+0.0050	0.0000	23.0000	+0.0060	0.0030	-0.0060	-0.0030
441.325	1000.000	+0.254	+0.152	584.000	1778.000	+0.254	0.127	-0.254	-0.127
17.3750	39.3701	+0.0100	+0.0060	23.0000	70.0000	+0.0100	0.0050	-0.0100	-0.0050

\* Dowel pin suggested.

\*\* Dowel pin required.



FITTING PRACTICES - continued

**SHAFT AND HOUSING FITS  
THRUST SPHERICAL ROLLER BEARING**

Tolerances for housing bore and for shaft diameters are shown as variance from nominal bearing dimension. Data is shown in inches over millimeters. When application calls for thrust loads only, the housing must be relieved by 1/16 in. on diameter so that no radial load is carried on the bearing. All tolerances are in number of micrometers (µm) and ten thousandths of an inch (.0001 in.).

SHAFT						HOUSING							
Tolerances are 1/1000 of a millimeter (µm) and 1/10,000 of an inch (5 = .0005")						Tolerances are 1/1000 of a millimeter (µm) and 1/10,000 of an inch (5 = .0005")							
Bearing Bore		Shaft Diameter				Bearing O.D.		Housing Bore					
Nominal (Max.)		Stationary Load		Rotating Load		Nominal (Max.)		Springs in Housing Light Radial Load		Combined Axial & Radial Load			
inches		Max.	Min.	Max.	Min.	inches		Min. Max.		Stationary Outer Ring		Rotating Outer Ring	
over	incl.	mm	mm	mm	mm	over	incl.	mm	mm	mm	mm	mm	mm
in.	in.	in.	in.	in.	in.	in.	in.	in.	in.	in.	in.	in.	in.
80	120	+13	-10	+25	+3	180	250	+15	+61	-18	+28	-33	+13
3.1496	4.7244	+5	-4	+10	+1	7.0866	9.8425	+6	+24	-7	+11	-13	+5
120	180	+15	-10	+28	+3	250	315	+18	+69	-18	+33	-36	+15
4.7244	7.0866	+6	-4	+11	+1	9.8425	12.4016	+7	+27	-7	+13	-14	+6
180	200	+18	-13	+36	+5	315	400	+18	+74	-18	+38	-41	+15
7.0866	7.8740	+7	-5	+14	+2	12.4016	15.7480	+7	+29	-7	+15	-16	+6
200	240	+18	-13	+46	+15	400	500	+20	+84	-23	+41	-46	+18
7.8740	9.4488	+7	-5	+18	+6	15.7480	19.6850	+8	+33	-9	+16	-18	+7
240	315	+18	-15	+51	+20	500	630	+23	+91	-23	+46	-48	+20
9.4488	12.4016	+7	-6	+20	+8	19.6850	24.8031	+9	+36	-9	+18	-19	+8
315	400	+18	-18	+56	+20	630	800	+23	+102	-23	+51	-51	+23
12.4016	15.7480	+7	-7	+22	+8	24.8031	31.4960	+9	+40	-9	+20	-20	+9
400	500	+23	-18	+86	+46	800	1000	+25	+109	-25	+58	-58	+25
15.7480	19.6850	+9	-7	+34	+18	31.4960	39.3700	+10	+43	-10	+23	-23	+10
500	630	+23	-20	+86	+43	1000	1250	+28	+122	-28	+66	-64	+30
19.6850	24.8031	+9	-8	+34	+17	39.3700	49.2126	+11	+48	-11	+26	-25	+12

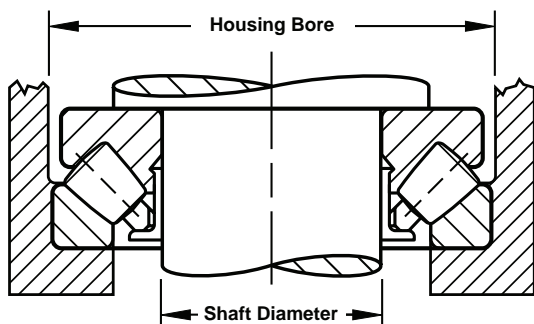

FITTING PRACTICES - continued

SHAFT AND HOUSING FITS  
THRUST CYLINDRICAL ROLLER BEARINGS

SHAFT TYPE TP AND TPS			
Tolerances for housing bore and for shaft diameters shown as variance from nominal bearing dimension. Data shown in millimeters over inches.			
Bearing Bore Nominal (Min.)		Shaft Diameter	
over	incl.	Max.	Min.
mm	mm	mm	mm
in.	in.	in.	in.
47.625	53.975	-0.025	-0.051
1.8750	2.1250	-0.0010	-0.0020
53.975	63.500	-0.028	-0.053
2.1250	2.5000	-0.0011	-0.0021
63.500	76.200	-0.030	-0.056
2.5000	3.0000	-0.0012	-0.0022
76.200	88.900	-0.033	-0.058
3.0000	3.5000	-0.0012	-0.0023
88.900	177.800	-0.038	-0.064
3.5000	7.0000	-0.0015	-0.0025
177.800	228.600	-0.038	-0.076
7.0000	9.0000	-0.0015	-0.0030
228.600	304.800	-0.046	-0.084
9.0000	12.0000	-0.0018	-0.0033
304.800	381.000	-0.051	-0.089
12.0000	15.0000	-0.0020	-0.0035
381.000	482.600	-0.051	-0.102
15.0000	19.0000	-0.0020	-0.0040
482.600	584.200	-0.064	-0.114
19.0000	23.0000	-0.0025	-0.0045
584.200	762.000	-0.076	-0.140
23.0000	30.0000	-0.0030	-0.0055

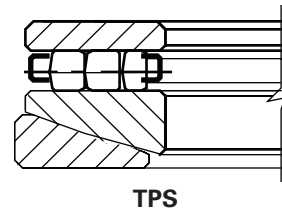
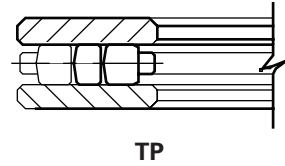

HOUSING TYPE TPS			
Deviations in $\mu\text{m}$ / 0.0001 inches			
Bearing O. D. Nominal (Min.)		Housing Diameter Deviation from D	
over	incl.	high	low
mm	mm	mm	mm
in.	in.	in.	in.
50.800	60.325	+38	+13
2.0000	2.3750	+15	+5
60.325	82.550	+43	+18
2.3750	3.2500	+17	+7
82.550	93.663	+48	+23
3.2500	3.6875	+19	+9
93.663	101.600	+53	+28
3.6875	4.0000	+21	+11
101.600	115.092	+71	+33
4.0000	4.5312	+28	+13
115.092	254.000	+76	+38
4.5312	10.0000	+30	+15
254.000	457.200	+102	+51
10.0000	18.0000	+40	+20
457.200	558.800	+127	+64
18.0000	22.0000	+50	+25
558.800	660.400	+140	+64
22.0000	26.0000	+55	+25
660.400	711.200	+152	+76
26.0000	28.0000	+60	+30
711.200	863.600	+178	+76
28.0000	34.0000	+70	+30
863.600	965.200	+203	+89
34.0000	38.0000	+80	+35
965.200	1117.600	+229	+102
38.0000	44.0000	+90	+40

HOUSING TYPE TP			
Bearing O. D. Nominal (Min.)		Housing Bore	
over	incl.	Max.	Min.
mm	mm	mm	mm
in.	in.	in.	in.
115.092	254.000	+0.076	+0.038
4.5312	10.0000	+0.0030	+0.0015
254.000	457.200	+0.102	+0.051
10.0000	18.0000	+0.0040	+0.002
457.200	558.800	+0.127	+0.064
18.0000	22.0000	+0.0050	+0.0025
558.800	660.400	+0.140	+0.064
22.0000	26.0000	+0.0055	+0.0025
660.400	711.200	+0.152	+0.076
26.0000	28.0000	+0.0060	+0.0030
711.200	863.600	+0.178	+0.076
28.0000	34.0000	+0.0070	+0.0030
863.600	965.200	+0.203	+0.089
34.0000	38.0000	+0.0080	+0.0035
965.200	1117.600	+0.229	+0.102
38.0000	44.0000	+0.0090	+0.0040

FITTING PRACTICES - continued

SHAFT AND HOUSING FITS  
THRUST TAPERED ROLLER BEARINGS

Tolerances for housing bore and shaft diameters are shown as variance from nominal bearing dimension. Data is shown in millimeters over inches. When one washer is piloted by the housing, sufficient clearances must be allowed at the outside diameter of the other washer as well as at the bore of both washers to prevent cross-loading of the rollers. For most applications, this clearance is approximately 1/16 in. (1.588 mm, .0625 in.).

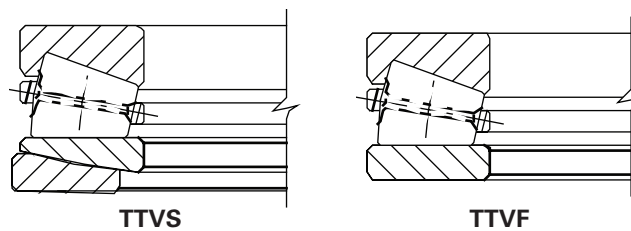

SHAFT			
TYPES TTVS AND TTVF			
Bearing Bore Nominal (Min.)		Shaft Diameter	
over	incl.	Max. +0 Min.	
mm	mm	mm	
in.	in.	in.	
0.000	304.800	-0.051	
0.0000	12.0000	-0.0020	
304.800	508.000	-0.051	
12.0000	20.0000	-0.0020	
508.000	711.200	-0.076	
20.0000	28.0000	-0.0030	
711.200	1219.200	-0.102	
28.0000	48.0000	-0.0040	
1219.200	1727.200	-0.127	
48.0000	68.0000	-0.0050	

HOUSING				
TYPES TTVS AND TTVF				
Bearing Bore Nominal (Min.)		Housing Bore		
over	incl.	Max.	Min.	
mm	mm	mm	mm	
in.	in.	in.	in.	
161.925	265.113	+0.060	+0.025	
6.3750	10.4375	+0.0025	+0.0010	
265.113	317.500	+0.076	+0.025	
10.3475	12.5000	+0.0030	+0.0010	
317.500	482.600	+0.102	+0.051	
12.5000	19.0000	+0.0040	+0.0020	
482.600	603.250	+0.113	+0.051	
19.0000	23.7500	+0.0045	+0.0020	
603.250	711.200	+0.152	+0.076	
23.7500	28.0000	+0.0060	+0.0030	
711.200	838.200	+0.178	+0.076	
28.0000	33.0000	+0.0070	+0.0030	

FITTING GUIDELINES - TTHD BEARINGS

(Tolerances and fits in µm and 0.0001 in.)

BORE mm (in.)		Rotating Race						Stationary Race Class 2 and 3	
over	incl.	Tolerance	Class 2 Shaft O.D. Deviation	Resultant Fit	Tolerance	Class 3 Shaft O.D. Deviation	Resultant Fit		
0	304.800	0	+76	76 T	0	+51	51 T		
		+25	+50	25 T	+13	+38	25 T		
0	12	0	+30	30 T	0	+20	20 T		
		+10	+20	10 T	+5	+15	10 T		
304.800	609.600	0	+152	152 T	0	+102	102 T		
		+51	+102	51 T	+25	+76	51 T		
12	24	0	+60	60 T	0	+40	40 T		
		+20	+40	20 T	+10	+30	20 T		
609.600	914.400	0	+204	204 T	0	+127	127 T		
		+76	+127	51 T	+38	+89	51 T		
24	36	0	+80	80 T	0	+50	50 T		
		+30	+50	20 T	+15	+35	20 T		
914.400	1219.200	0	+254	254 T	0	+153	153 T		
		+102	+153	51 T	+51	+102	51 T		
36	48	0	+100	100 T	0	+60	60 T		
		+40	+60	20 T	+20	+40	20 T		
1219.200		0	+305	305 T	0	+204	204 T		
		+127	+178	51 T	+76	+127	51 T		
48		0	120	+120 T	0	+80	80 T		
		+50	+70	20 T	+30	+50	20 T		

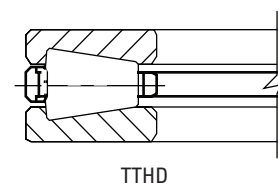

All sizes Provide a minimum radial clearance of 2.5 mm (0.1 in.) between race bore and shaft O.D.

- Rotating race O.D. must have a minimum radial clearance of 2.5 mm (0.1 in.)
- TTHD stationary race O.D. must have a minimum loose fit of 0.25 to 0.37 mm (0.01 to 0.015 in.)
- TTHDFL washer when stationary may be loose fit on its O.D. (same as the TTHD) or may be 0.025 to 0.076 mm (0.001 to 0.003 in.) tight.

# A BEARING SETTING

## SETTING TAPERED ROLLER BEARINGS

Setting is defined as a specific amount of either endplay or preload. Establishing the setting at the time of assembly is an inherent advantage of tapered roller bearings. They can be set to provide optimum performance in almost any application. The following figure gives an example of the relationship between fatigue life and bearing setting. Unlike some types of anti-friction bearings, tapered roller bearings do not rely strictly on housing or shaft fits to obtain a certain bearing setting. One race can be moved axially relative to the other to obtain the desired bearing setting.

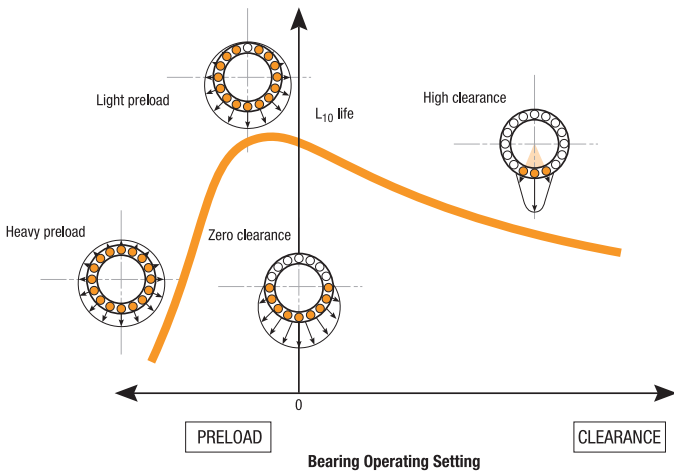

Relationship between bearing setting and fatigue life.

At assembly, the conditions of bearing setting are defined as:

- **Endplay** – An axial clearance between rollers and races producing a measurable axial shaft movement when a small axial force is applied - first in one direction, then in the other, while oscillating or rotating the shaft.
- **Preload** – An axial interference between rollers and races such that there is no measurable axial shaft movement when a small axial force is applied – in both directions, while oscillating or rotating the shaft.
- **Line-to-line** – A zero setting condition: the transitional point between endplay and preload.

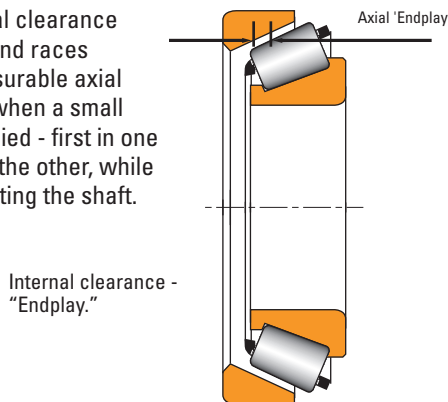

Bearing setting obtained during initial assembly and adjustment is the cold or ambient bearing setting and is established before the equipment is subjected to service.

Bearing setting during operation is known as the operating bearing setting and is a result of changes in the ambient bearing setting due to thermal expansion and deflections encountered during service.

The ambient bearing setting necessary to produce the optimum operating bearing setting varies with the application. Application experience, or testing, generally permits the determination of optimum settings. Frequently, however, the exact relationship of ambient to operating bearing setting is an unknown and an educated estimate has to be made. To determine a suggested ambient bearing setting for a specific application, consult your Timken representative.

Generally, the ideal operating bearing setting is near zero to maximize bearing life. Most bearings are set with endplay at assembly to reach the desired near zero setting at operating temperature when mounted.

### Standard mounting

$$\text{Operating setting} = \text{mounted setting} \pm \text{temperature effect} \pm \text{deflection}$$

### Pre-set assemblies

$$\text{Mounted EP or PL} = \text{Bench EP or Bench PL} - \text{effect of fits}$$

$$\text{Operating setting} = \text{mounted EP or PL (MEP or MPL)} \pm \text{temperature effect} \pm \text{deflection}$$

The temperature and fit effects will depend upon the type of mounting, bearing geometry and size, shaft and housing size and material according to the following sketch:

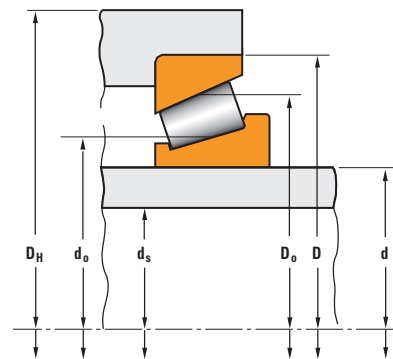

Dimensions affecting the effects of temperature and fit.

BEARING SETTING - *continued*

TEMPERATURE EFFECT  
(IN A TWO-ROW MOUNTING)

Symbols used:

- $\delta_S$  = interference fit of inner race on shaft
- $\delta_H$  = interference fit of outer race in housing
- $K_n$  = K-factor for bearing #n
- $d$  = bearing bore diameter
- $d_o$  = mean inner race diameter
- $D$  = bearing outside diameter
- $D_o$  = mean outer race diameter
- $L$  = distance between bearing geometric center lines, mm (in.)
- $\alpha$  = coefficient of linear expansion:  $11 \times 10^{-6}/^\circ\text{C}$  ( $6.1 \times 10^{-6}/^\circ\text{F}$ ) for ferrous metal shaft and housing materials
- $d_S$  = shaft inside diameter
- $D_H$  = housing outside diameter
- $\Delta T$  = temperature difference between shaft/inner race + rollers and housing/bearing outer race

DIRECT MOUNTING

$$\text{Thermal Lateral Loss} = \alpha \Delta T \left[ \left( \frac{K_1}{0.39} \times \frac{D_{o1}}{2} \right) + \left( \frac{K_2}{0.39} \times \frac{D_{o2}}{2} \right) + L \right]$$

INDIRECT MOUNTING

$$\text{Thermal Lateral Loss} = \alpha \Delta T \left[ \left( \frac{K_1}{0.39} \times \frac{D_{o1}}{2} \right) + \left( \frac{K_2}{0.39} \times \frac{D_{o2}}{2} \right) - L \right]$$

Note: Positive lateral loss is the amount of setting reduction or loss of endplay.

FIT EFFECT (SINGLE-ROW)

SOLID SHAFT/HEAVY SECTION HOUSING

Inner Race:

$$F = 0.5 \left( \frac{K}{0.39} \right) \left( \frac{d}{d_o} \right) \delta_S$$

Outer Race:

$$F = 0.5 \left( \frac{K}{0.39} \right) \left( \frac{D}{D_o} \right) \delta_H$$

Hollow shaft/thin wall section

Inner Race:

$$F = 0.5 \left( \frac{K}{0.39} \right) \left( \frac{d}{d_o} \right) \left[ \frac{1 - \left( \frac{d_s}{d} \right)^2}{1 - \left( \frac{d_s}{d_o} \right)^2} \right] \delta_S$$

Note: These equations apply only to ferrous shaft and housing.

Outer Race:

$$F = 0.5 \left( \frac{K}{0.39} \right) \left( \frac{D_o}{D} \right) \left[ \frac{1 - \left( \frac{D}{D_H} \right)^2}{1 - \left( \frac{D_o}{D_H} \right)^2} \right] \delta_H$$

SETTING METHODS FOR  
TAPERED ROLLER BEARINGS

Upper and lower limits of bearing setting value are determined by consideration of the following factors:

- Application type.
- Duty.
- Operational features of adjacent mechanical drive elements.
- Changes in bearing setting due to temperature differentials and deflections.
- Size of bearing and method of obtaining bearing setting.
- Lubrication method.
- Housing and shaft material.

The setting value to be applied during assembly will depend on any changes that may occur during operation. In the absence of experience with bearings of similar size and operating conditions, bearing setting range suggestions should be obtained from your Timken representative.

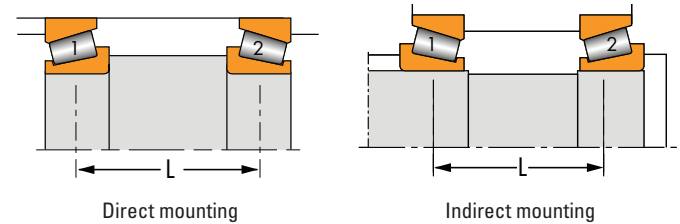

Use the push-pull method (manual setting) to measure any axial endplay (used as reference) while rotating the shaft or the housing. Correct this reference value to the final required endplay or preload by changing the setting on the adjusting device. Fig. A-25 and A-26 are typical examples of manual setting applications.

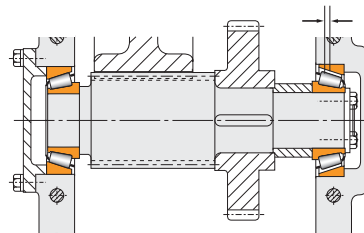

Fig. A-25  
Axial clearance (endplay).

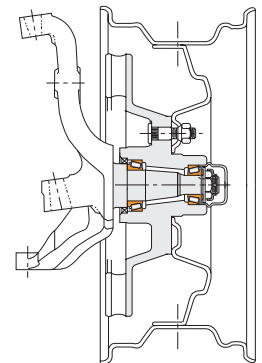
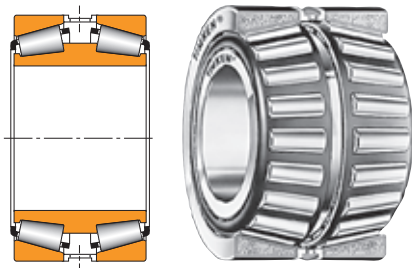

Fig. A-26  
Truck nondriven wheel.

BEARING SETTING - *continued*

PRESET BEARING ASSEMBLIES



TDI with outer race spacer

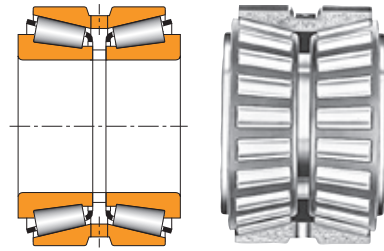

TDO with inner race spacer

Fig. A-27  
Typical preset  
bearing  
assemblies.

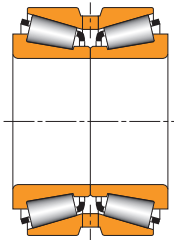

TNA

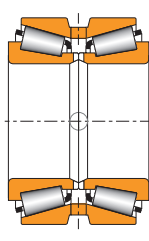

TNASW

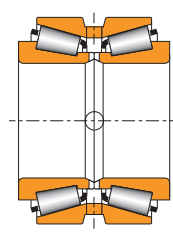

TNASWE

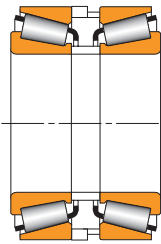

SR

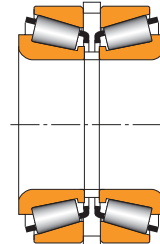

SS

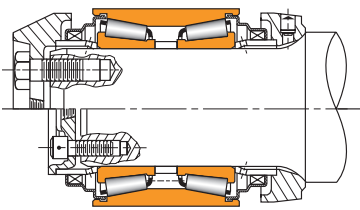
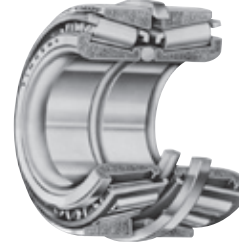

AP

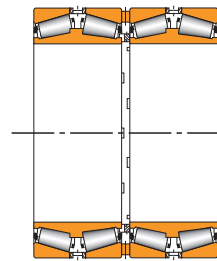

TQ0

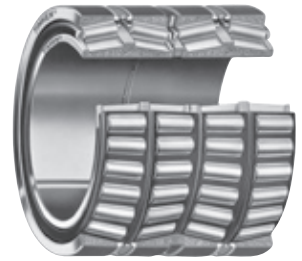

If the application requires the use of multi-row bearing assemblies, preset bearings can be used (Fig. A-27). Various types of multi-row bearing combinations can be provided with spacers that are ground and custom-fitted to provide a bearing setting to meet the requirements of the application (Fig. A-28). Types SS, TDI, TDIT and TDO, listed in this publication, are examples.

Each matched assembly has an identifying serial number marked on each outer race, inner race and spacer. Some small preset assemblies are not marked with a serial number but their component parts are supplied as a boxed set.

A preset bearing assembly contains a specific fixed internal clearance (or preload) built in during manufacture. The value of this "setting" is referred to as "bench endplay" (BEP) or "bench preload" (BPL) and is normally determined by The Timken Company during the design stage of new equipment. Components from one bearing assembly are NOT interchangeable with similar parts from another.

Bearing settings for types TNA, TNASW, TNASWE (standard version) and SR bearings are obtained through close axial tolerance control and components from these assemblies are interchangeable for bearings having bore sizes under 305 mm (12 in.).



**BEARING SETTING - continued**

The Timken Company has developed various automated bearing setting techniques. The advantages of these techniques are:

- Reduced set-up time.
- Reduced assembly cost.
- Increased consistency and reliability of bearing settings.
- In most cases they can be applied to the assembly line for moderate and high volume production.

It is possible to select and adapt one of the following automated setting methods for a wide range of applications.

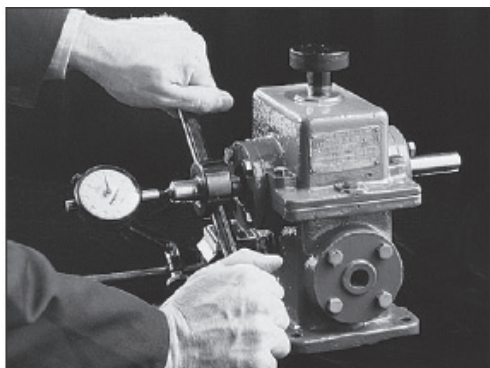

**Fig. A-28**  
Bearing setting.

**“Set-Right”™**

This technique applies the laws of probability. The setting in the bearing is controlled by the radial and axial tolerances of the various components of the assembly.

**“Acro-Set”™**

The Acro-Set method is achieved through measurement of a shim or spacer gap with a specified set-up load applied. The correct shim or spacer dimension is then taken from a prepared chart or by a direct instrument reading. This technique is based on Hooke’s law, which states that within the elastic limit, deformation or deflection is proportional to the load applied. It is applicable to either endplay or preload bearing settings.

**“Torque-Set”™**

The Torque-Set technique is a method of obtaining correct bearing settings by using low-speed bearing rolling torque as a basis for determining the amount of deformation or deflection of the assembly parts affecting bearing settings. This technique is applicable regardless of whether the final bearing setting is preload or endplay.

**“Projecta-Set”™**

The Projecta-Set technique is used to “project” an inaccessible shim or spacer gap to a position where it can easily be measured. This is achieved using a spacer and a gauging sleeve. The Projecta-Set technique is of most benefit on applications where the inner and outer races are an interference fit and therefore disassembly for adjustment is more difficult and time-consuming than with loose-fitting races.

Deciding which automated bearing setting technique should be used must be made early in the design sequence. It is necessary to review each application to determine the most economical method and necessary fixtures and tools. The final decision will be based on the size and weight of the unit, machining tolerances, production volume, access to retaining devices (locknuts, end plates, etc.) and available tools. Your Timken representative can assist in determining the best method to obtain the correct bearing setting.

## DUPLEX SETS OF BALL BEARINGS AND PRELOADING

Two single-row ball bearings manufactured specially for use as a unit are known as a duplex bearing. It may be considered analogous to a double-row bearing having the same bore and outside diameter, but twice the single-row bearing width.

The main purpose of duplex bearings in an application is to achieve greater axial and radial rigidity than is possible with one single-row bearing. The extra “stiffness” in these bearings is obtained by “preloading.” Preloading is incorporated into bearings by selective face grinding which is described in detail below.

Although angular contact bearings, such as the 7000, M-WI and MMWI types, are more commonly used in duplex arrangements, other types of bearings such as radial single-row open, shielded and sealed types, can be duplexed where required to meet specific conditions.

**PRELOADING**

Preloading to a predetermined value is accomplished by grinding a certain amount of material off inner or outer ring faces so that before mounting the two single bearings as a duplex pair, the faces on abutting sides are offset an amount equal to the deflection under the “preload.”

When mounted, these faces are clamped together so that the bearings are subjected to an internal load caused by one bearing opposing the other. This “preloading” materially decreases subsequent deflection due to external loads applied to the clamped-up pair.

Timken has established, for each bearing size, standard preload levels which are considered proper for most duplex bearing applications. Special preloads can also be provided to satisfy

**BEARING SETTING - continued**

extreme requirements. For example, a heavily loaded, slow-speed rotating shaft may require heavier than normal preload in order to minimize deflection. It must be remembered, however, that although heavy preload provides slightly greater rigidity, it reduces bearing life and increases power consumption; therefore preload levels should be chosen with care.

The axial deflection of a bearing subject to thrust loading is based on Hertz's theories for elastic bodies in contact. The general expression is:

$$\delta = K \left( \frac{T^2}{nd^2} \right)^{1/3}$$

- where  $\delta$  = axial deflection
- K = a constant based on bearing geometry
- T = thrust load applied
- n = number of balls
- d = ball diameter

A typical axial deflection curve for an unpreloaded single-row angular contact bearing is shown in Figure A-29, as curve A. This curve represents the deflection characteristics of bearing "A" being subjected to thrust load T. The amount of deflection due to load  $T_1$  is much greater than the increase in deflection caused by doubling the thrust load to  $T_2$ . This illustrates the non-linear deflection of a ball bearing.

Curves  $C_1$  and  $C_2$  show the deflection of bearings A and B flushmounted as a pair, shown below, with each bearing having a preload of  $T_1$  and  $T_2$  lbs., respectively. Comparing curves  $C_1$  and  $C_2$  with A shows the deflection of the preloaded pair is much less than that of a single unpreloaded bearing. This has been accomplished essentially by eliminating the "high deflection" points of curve A (from no load to  $T_1$  or  $T_2$  lbs.).

Curves  $B_1$  and  $B_2$  show the axial deflection of bearing B as mounted in Figure A-30 below from the preloaded conditions  $T_1$  or  $T_2$  to a no preload condition.

Preloading can be accomplished by the use of springs or spacer width adjustment, but your Timken representative should be consulted for design review.

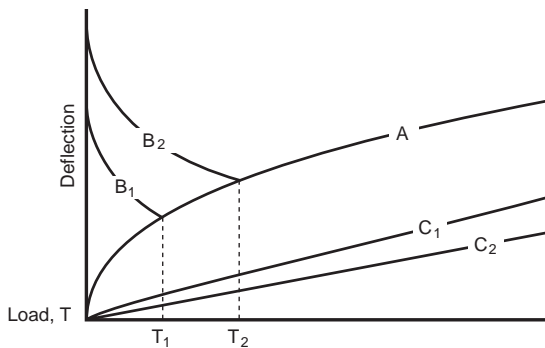

**Fig. A-29**  
Axial load-deflection curve of back-to-back mounted angular-contact bearings. Curve A is for Bearing A, B is for bearing B, and  $C_1$  and  $C_2$  are preload curves.

**TYPICAL APPLICATIONS**

Deep well pumps, marine propeller shafts, machine tool spindles, gear shafts, speed reducers, elevator worm drives, and similar applications often require the use of preloaded duplex bearings.

**WIDTH TOLERANCES**

To allow for face grinding of single bearings to specified preload for use in duplex pairs or other multiple bearing units, the inner and outer ring width tolerance of each bearing is greater than that for a standard single bearing as follows:

Bearing Bore mm		Width Tolerance ABEC	Width Tolerance ABEC
over	incl.	1,3	5,7,9
0	50	+0.000" -.010"	+0.000" -.010"
50	80	+0.000" -.015"	+0.000" -.010"
80	120	+0.000" -.015"	+0.000" -.015"
120	180	+0.000" -.020"	+0.000" -.015"
180	315	+0.000" -.020"	+0.000" -.020"
315	400	+0.000" -.025"	+0.000" -.025"

The inner and outer ring width tolerances of duplex pairs and other multiple bearing units equal the tolerances listed above times the number of bearings in the unit. For example, a duplex pair of 2MM9115 WI DUL bearings has an inner and outer ring width tolerance of .010 in x 2 or .020 in.

**MOUNTINGS OF BALL BEARINGS**

Duplex bearings may be used with spacers between the matching faces in order to increase the system's resistance to moment loading or to increase the system rigidity by using the bearings to minimize shaft deflection. Shaft and housing spacers should be ground together on a surface grinder to obtain exactly equal lengths to assure that the built-in preload will be maintained. Since duplex bearings provide a very rigid mounting, it is important that special attention be given to correct shaft and housing fits, squareness of shaft and housing shoulders and alignment of all mating parts. In order to prevent cramping of bearings and an abnormal increase in preload which could result in excessive heat and possible bearing damage, suggested shaft and housing tolerances must be followed, shaft and housing shoulders must be square, bearing spacers must be of equal length and all parts must be free of nicks and burrs.

Typical preloaded mountings are shown here.

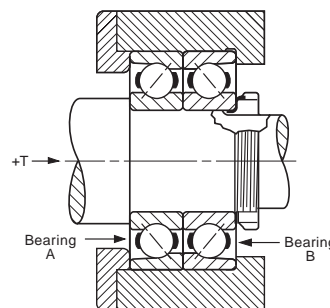

**Fig. A-30**  
Typical preload mountings

BEARING SETTING - *continued*

## TYPICAL MOUNTINGS OF DUPLEX BEARINGS

**Back-to-Back Mounting, DB or ("O")**  
**(Contact angles diverging toward shaft centerline)**

Before mounting, there is clearance between the two adjacent inner ring faces. After mounting, these faces are clamped together to provide an internal preload on each bearing. This arrangement is well suited for pulleys, sheaves and in other applications where there are overturning loads and also in all floating positions where thermal expansion of shaft occurs. It also provides axial and radial rigidity and equal thrust capacity in either direction when used in a fixed location. Back-to-back is the most commonly used of all duplex arrangements. Specify bearing number followed by suffix DU. Examples: 7207W-DU, 2MM207W1-DU. Also available as two single flush-ground bearings, e.g., 7207W SU (2 bearings).

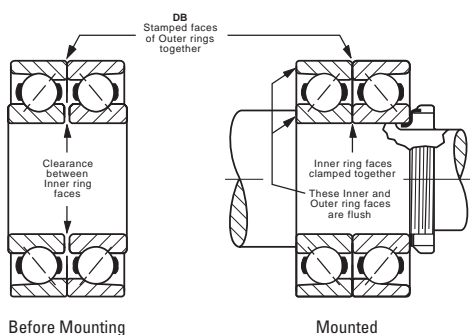
**Tandem Mounting, DT**

Before mounting, the inner ring faces of each bearing are offset from the outer ring faces. After mounting, when a thrust load is applied equal to that of twice the normal preload, the inner and outer ring faces are brought into alignment on both sides. This arrangement provides double thrust capacity in one direction only. More than two bearings can be used in tandem if additional thrust capacity is required. Timken pairs for tandem mounting should be specified as DU. Examples: 7205W-DU, 2M205W1-DU. Also available as two single flush-ground bearings with suffix SU, e.g., 7210W SU (two bearings).

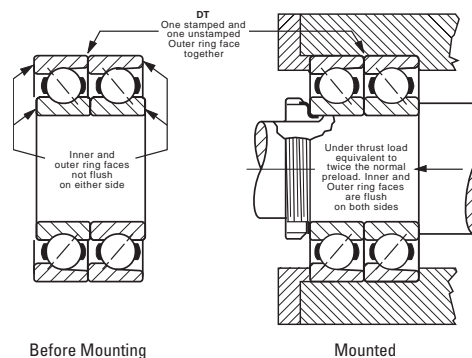
**Face-to-Face Mounting, DF or ("X")**  
**(Contact angles converging toward shaft centerline)**

Before mounting, there is clearance between the two adjacent outer ring faces. After mounting, these faces are clamped together between the housing shoulder and cover plate shoulder providing an internal preload on each bearing. This arrangement provides equal thrust capacity in either direction as well as radial and axial rigidity. Since the face-to-face mounting has inherent disadvantages of low resistance to moment loading and thermal instability, it should not be considered unless a significantly more convenient method of assembly or disassembly occurs from its use. Timken pairs for face-to-face mounting should be ordered as DU. Examples: 7212W-DU, 2M212W1-DU. Also available as two single flush-ground bearings, e.g., 7212W SU (two bearings).

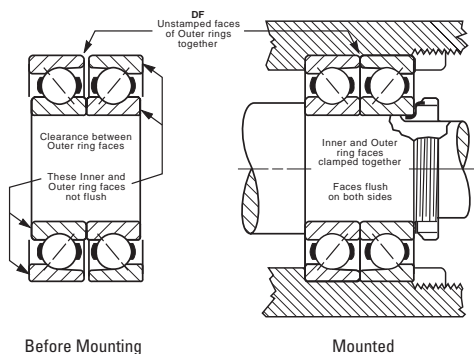
**Other Mountings**

Flush ground (DU) pairs may be mounted in combination with a single flush-ground bearing as a "triplex" (TU) set shown below illustrates a "quadruplex" (QU) set where three bearings in tandem are mounted back-to-back with a single bearing. These arrangements provide high capacity in one direction and also a positively rigid mounting capable of carrying a moderate amount of reverse thrust.

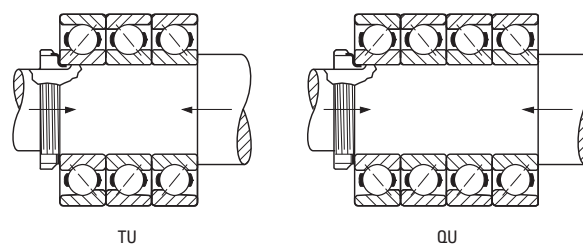

# A LUBRICATION AND SEALS

## LUBRICATION

To help maintain a rolling bearing’s anti-friction characteristics, lubrication is needed to:

- Minimize rolling resistance due to deformation of the rolling elements and raceway under load by separating the mating surfaces.
- Minimize sliding friction occurring between rolling elements, raceways and cage.
- Transfer heat (with oil lubrication).
- Protect from corrosion and, with grease lubrication, from contaminant ingress.

Modern lubricants do this very effectively, although in many applications the means by which they accomplish this are extremely complex and not completely understood. Because the principles involved with lubricating rolling element bearings are complex and do not have to be known to employ lubricants successfully, this discussion will stress the practical rather than the theoretical aspects of lubrication.

## LUBRICATION SELECTION

The wide range of bearing types and operating conditions precludes any simple, all-inclusive statement or guideline allowing the selection of the proper lubricant. At the design level, the first consideration is whether oil or grease is best for the particular operation. The advantages of oil and grease are outlined in the table below. When heat must be carried away from the bearing, oil must be used. It is nearly always preferred for very high-speed applications. For limiting speeds of grease and oil-lubricated bearings, refer to the section entitled “Speed, Heat and Torque” section.

ADVANTAGES OF OIL AND GREASE	
OIL	GREASE
Carries heat away from the bearings	Simplifies seal design and acts as a sealant
Carries away moisture and particulate matter	Permits prelubrication of sealed or shielded bearings
Easily controlled lubrication	Generally requires less frequent lubrication

## LUBRICANT ADDITIVES

Additives are materials, usually chemicals, that improve specific properties when added to lubricants. Additives, when properly formulated into a lubricant, can increase lubricant life, provide greater resistance to corrosion, increase load-carrying capacity and enhance other properties. Additives are very complex and should not be added indiscriminately to lubricants as a cure-all for all lubrication problems.

The more common lubricant additives include:

- Oxidation inhibitors for increasing lubricant service life.
- Rust or corrosion inhibitors to protect surfaces from rust or corrosion.

- Demulsifiers to promote oil and water separation.
- Viscosity-index improvers to decrease viscosity sensitivity to temperature change.
- Pour-point depressants to lower the pouring point at low temperatures.
- Lubricity agents to modify friction.
- Antiwear agents to retard wear.
- Extreme pressure (EP) additives to prevent scoring under boundary-lubrication conditions.
- Detergents and dispersants to maintain cleanliness.
- Antifoam agents to reduce foam.
- Tackiness agents to improve adhesive properties.

Inorganic additives such as molybdenum disulphide, graphite, and zinc oxide are sometimes included in lubricants. In most tapered roller bearing applications, inorganic additives are of no significant benefit; conversely, as long as the concentration is low and the particle size small, they are not harmful.

Recently, the effects of lubricant chemistry on bearing life (as opposed to the purely physical characteristics) have received much emphasis. Rust, oxidation, extreme pressure and anti-wear additive packages are widely used in engine and gear oils. Fatigue testing has shown these additives may, depending on their chemical formulation, concentration and operating temperature, have a positive or negative impact on bearing life.

Consult your Timken representative for more information regarding lubricant additives.

## GUIDANCE FOR OIL/GREASE SELECTION

### Oil lubrication

Oils used for bearing lubrication should be high-quality, non-oxidizing mineral oils or synthetic oils with similar properties. Selection of the proper type of oils depends on bearing speed, load, operating temperature and method of lubrication.

Some features and advantages of oil lubrication, in addition to the above, are as follows:

- Oil is a better lubricant for high speeds or high temperatures. It can be cooled to help reduce bearing temperature.
- With oil, it is easier to handle and control the amount of lubricant reaching the bearing. It is harder to retain in the bearing. Lubricant losses may be higher than with grease.
- As a liquid, oil can be introduced to the bearing in many ways, such as drip-feed, wick-feed, pressurized circulating systems, oil-bath or air-oil mist. Each is suited to certain types of applications.
- Oil is easier to keep clean for recirculating systems. Oil may be introduced to the bearing housing in many ways.

## LUBRICATION AND SEALS - *continued*

The most common systems are:

- **Oil bath.** The housing is designed to provide a sump through which the rolling elements of the bearing will pass. Generally, the oil level should be no higher than the center point of the lowest rolling element. If speed is high, lower oil levels should be used to reduce churning. Gages or controlled elevation drains are used to achieve and maintain the proper oil level.
- **Circulating system.** This system has the advantages of:
  - An adequate supply of oil for both cooling and lubrication.
  - Metered control of the quantity of oil delivered to each bearing.
  - Removal of contaminants and moisture from the bearing by flushing action.
  - Suitability for multiple bearing installations.
  - Large reservoir, which reduces deterioration. Increased lubricant life provides economical efficiency.
  - Incorporation of oil filtering devices.
  - Positive control to deliver the lubricant where needed.

A typical circulating oil system consists of an oil reservoir, pump, piping and filter. A cooler may be required.

- **Oil-mist lubrication.** Oil-mist lubrication systems are used in high-speed, continuous operation applications. This system permits close control of the amount of lubricant reaching the bearings. The oil may be metered, atomized by compressed air and mixed with air, or it may be picked up from a reservoir using a venturi effect. In either case, the air is filtered and supplied under sufficient pressure to assure adequate lubrication of the bearings. Control of this type of lubrication system is accomplished by monitoring the operating temperatures of the bearings being lubricated. The continuous passage of the pressurized air and oil through the labyrinth seals used in the system prevents the entrance of contaminants from the atmosphere to the system. The successful operation of this type of system is based upon the following factors: proper location of the lubricant entry ports in relation to the bearings being lubricated, avoidance of excessive pressure drops across void spaces within the system, the proper air pressure and oil quantity ratio to suit the particular application, and the adequate exhaust of the air-oil mist after lubrication has been accomplished. To ensure "wetting" of the bearings and to prevent possible damage to the rolling elements and races, it is imperative that the oil mist system be turned on for several minutes before the equipment is started. The importance of "wetting" the bearing before starting cannot be overstated and has particular significance for equipment that has been idled for extended periods of time.

## WARNING

**Proper maintenance and handling practices are critical. Failure to follow installation instructions and to maintain proper lubrication can result in equipment failure, creating a risk of serious bodily harm.**

## OIL LUBRICATION GUIDELINES

### Oil lubrication

Lubricating oils are commercially available in many forms for automotive, industrial, aircraft and other uses. Oils are classified as either petroleum types (refined from crude oil) or synthetic types (produced by chemical synthesis).

### Petroleum oils

Petroleum oils are used for nearly all oil-lubricated applications of Timken bearings. These oils have physical and chemical properties that can help in the selection of the correct oil for any bearing application.

### Synthetic oils

Synthetic oils cover a broad range of categories, and include polyalphaolefins, silicones, polyglycols, and various esters. In general, synthetic oils are less prone to oxidation and can operate at extreme hot or cold temperatures. Physical properties such as pressure-viscosity coefficients tend to vary between oil types and caution should be used when making oil selections.

The polyalphaolefins (PAO) have a hydrocarbon chemistry, which parallel petroleum oil both in their chemical structures and pressure-viscosity coefficients. Therefore, PAO oil is mostly used in the oil-lubricated applications of Timken bearings when severe temperature environments (hot and cold) are encountered or when extended lubricant life is required. The silicone, ester and polyglycol oils have an oxygen based chemistry that is structurally quite different from petroleum oils and PAO oils. This difference has a profound effect on its physical properties where pressure-viscosity coefficients can be lower compared to mineral and PAO oils. This means that these types of synthetic oils may actually generate a smaller EHD film thickness than a mineral or PAO oil of equal viscosity at operating temperature. Reductions in bearing fatigue life and increases in bearing wear could result from this reduction of lubricant film thickness.

## SELECTION OF OILS

The selection of oil viscosity for any bearing application requires consideration of several factors: load, speed, bearing setting, type of oil, and environmental factors. Since viscosity varies inversely with temperature, a viscosity value must always be stated with the temperature at which it was determined. High viscosity oil is used for low-speed or high-ambient temperature applications. Low viscosity oil is used for high-speed or low-ambient temperature applications.

**Approximate Temperature Limits  
For Oils**

Petroleum	149° C	300° F
Super Refined Petroleum	177° C	350° F
Synthetic Hydrocarbon	204° C	400° F
Synthetic Esters	204° C	400° F
Silicones	260° C	500° F
Polyphenylether	288° C	550° F
Perfluorinated	316° C	600° F



LUBRICATION AND SEALS - continued

CLASSIFICATION

There are several classifications of oils based on viscosity grades. The most familiar are the Society of Automotive Engineers (SAE) classifications for automotive engine and gear oils. The American Society for Testing and Materials (ASTM) and the International Organization for Standardization (ISO) have adopted standard viscosity grades for industrial fluids. Fig. A-31 shows the viscosity comparisons of ISO/ASTM with SAE classification systems at 40° C.

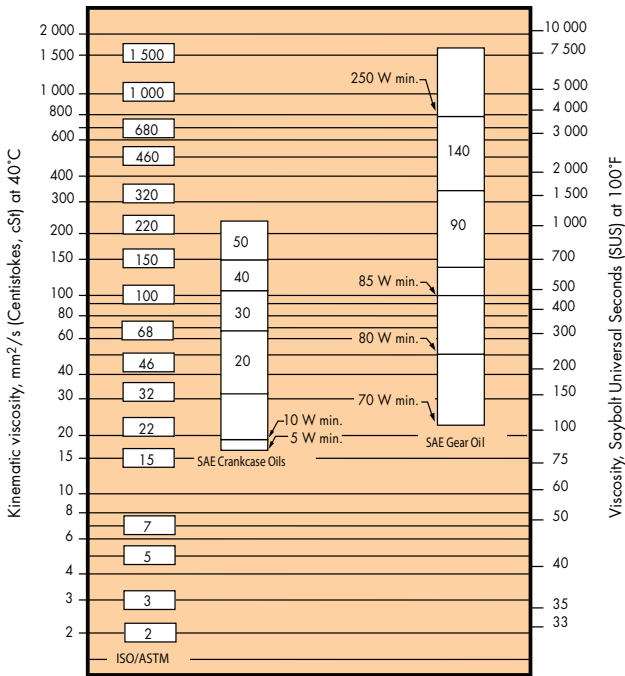

**Fig. A-31** Viscosity classification comparison between ISO/ASTM grades (ISO 3448/ASTM D2442) and SAE grades (SAE J 300-80 for crankcase oils, SAE J 306-81 for axle and manual transmission oils).

The figure below can be used to predict the oil's kinematic viscosity versus temperature (use base oil for grease).

TEMPERATURE VS. KINEMATIC VISCOSITY

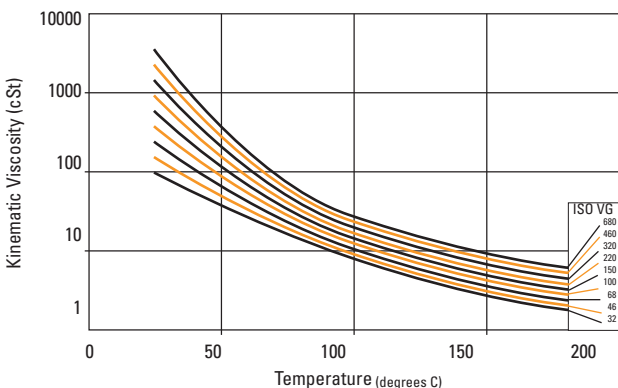

**Fig. A-31a**

TYPICAL OIL LUBRICATION GUIDELINES

In this section, the properties and characteristics of lubricants for typical tapered roller bearing applications are listed. These general characteristics have resulted from long successful performance in these applications.

General purpose rust and oxidation lubricating oil

General purpose rust and oxidation (R&O) inhibited oils are the most common type of industrial lubricant. They are used to lubricate Timken bearings in all types of industrial applications where conditions requiring special considerations do not exist.

SUGGESTED GENERAL PURPOSE R&O LUBRICATING OIL PROPERTIES

Base stock	Solvent refined, high viscosity-index petroleum oil
Additives	Corrosion and oxidation inhibitors
Viscosity index	80 min.
Pour point	-10° C max.
Viscosity grades	ISO/ ASTM 32 through 220

Some low-speed and/or high-ambient temperature applications require the higher viscosity grades, and high-speed and/or low-temperature applications require the lower viscosity grades.

Industrial extreme pressure (EP) gear oil

Extreme pressure gear oils are used to lubricate Timken bearings in all types of heavily loaded industrial equipment. They should be capable of withstanding heavy loads including abnormal shock loads common in heavy-duty equipment.

SUGGESTED INDUSTRIAL EP GEAR OIL PROPERTIES

Base stock	Solvent refined, high viscosity index petroleum oil
Additives	Corrosion and oxidation inhibitors. Extreme pressure (EP) additive* - 15.8 kg (35 lb) min. "OK" Timken load rating
Viscosity index	80 min.
Pour point	-10° C max.
Viscosity grades	ISO/ ASTM 100, 150, 220, 320, 460

\* ASTM D 2782

Industrial EP gear oils should be composed of a highly refined petroleum oil-based stock plus appropriate inhibitors and additives. They should not contain materials that are corrosive or abrasive to bearings. The inhibitors should provide long-term protection from oxidation and protect the bearing from corrosion in the presence of moisture. The oils should resist foaming in service and have good water separation properties. An EP additive protects against scoring under boundary-lubrication conditions. The viscosity grades suggested represent a wide range. High temperature and/or slow-speed applications generally require the higher viscosity grades. Low temperatures and/or high speeds require the use of lower viscosity grades.

## LUBRICATION AND SEALS - *continued*

### LUBRICATING GREASES

#### Definition

According to the ASTM definition, lubricating grease is a "solid to semi-fluid product of the dispersion of a thickening agent in a liquid lubricant; other ingredients imparting special properties may be included." If this definition were applied in the manner a chemist would use to illustrate a chemical reaction, the composition of a grease could be described by the formula below.

Fluids	+Thickening Agents	+Special Ingredients	=Lubricating Grease
Mineral Oils	Soaps	Oxidation Inhibitors	
Esters	Lithium, Sodium	Rust Inhibitors	
Organic Esters	Barium, Calcium	VI Improver	
Glycols	Strontium	Tackiness	
Silicones	Non-Soap (Inorganic)	Perfumes	
	Microgel (Clay)	Dyes	
	Carbon Black	Metal Deactivator	
	Silica-gel		
	Non-Soap (Organic)		
	Urea compounds		
	Terephthamate		
	Organic Dyes		

At this time, there is no known universal anti-friction bearing grease. Each individual grease has certain limiting properties and characteristics.

Synthetic lubricating fluids, such as esters, organic esters and silicones, are used with conventional thickeners or chemical additives to provide greases capable of performing over an extremely wide range of temperatures, from as low as -73° C (-100° F) to a high of 288° C (550° F).

The successful use of lubricating grease in roller bearings depends on the physical and chemical properties of the lubricant pertaining to the bearing, its application, installation and general environmental factors. Because the choice of a lubricating grease for a particular bearing under certain service conditions is often difficult to make, your Timken representative should be consulted for proper suggestions.

#### Grease lubrication

The simplest lubrication system for any bearing application is grease. Conventionally, greases used in Timken bearing applications are petroleum oils of some specific viscosity that are thickened to the desired consistency by some form of metallic soap. Greases are available in many soap types such as sodium, calcium, lithium, calcium-complex and aluminium-complex. Organic and inorganic type non-soap thickeners also are used in some products.

#### Soap type

Calcium greases have good water resistance. Sodium greases generally have good stability and will operate at higher temperatures, but they absorb water and cannot be used where moisture is present. Lithium, calcium-complex and aluminium-complex greases generally combine the higher temperature properties and stability of sodium grease with the water resistance of calcium grease. These greases are often referred to as multi-purpose greases since they combine the two most important lubricant advantages into one product.

### CHARACTERISTICS AND OPERATING ENVIRONMENTS

Listed below are the general characteristics of prominent rolling bearing greases.

Thickener	Typical Dropping PT		Usable** Temperature		Typical Water Resistance
	C	F	C	F	
Sodium Soap	260+	500+	121	250	Poor
Lithium Soap	193	380	104	220	Good
Polyurea	238	460	149	300	Excellent
Lithium Complex Soap	260+	500+	163	325	Good

\*\* Continuous operation with no relubrication. Depending upon the formulation the service limits may vary. The usable limit can be extended significantly with relubrication.

Polyurea as a thickener for lubricating fluids is one of the most significant lubrication developments in more than 30 years. Polyurea grease performance in a wide range of bearing applications is outstanding, and in a relatively short time it has gained acceptance as a factory-packed lubricant for ball bearings.

#### Consistency

Greases may vary in consistency from semifluids hardly thicker than a viscous oil, to solid grades almost as hard as a soft wood.

Consistency is measured by a penetrometer, in which a standard weighted cone is dropped into the grease. The distance the cone penetrates (measured in tenths of a millimeter in a specific time) is the penetration number.

The National Lubricating Grease Institute (N.L.G.I.) classification of grease consistency is shown below:

NLGI Grease Grades	Penetration Number
0	355-385
1	310-340
2	265-295
3	220-250
4	175-205
5	130-160
6	85-115

Grease consistency is not fixed; it normally becomes softer when sheared or "worked." In the laboratory this "working" is accomplished by forcing a perforated plate up and down through a closed container of grease. This "working" does not compare with the violent shearing action that takes place in a ball bearing and does not necessarily correlate with actual performance.

LUBRICATION AND SEALS - *continued*

**Low Temperatures**

Starting torque in a grease-lubricated ball bearing at low temperatures can be critical. Some greases may function adequately as long as the bearing is operating, but resistance to initial movement is such that the starting torque is excessive. In certain smaller machines, starting is an impossibility when very cold. Under such operating circumstances, the greases containing low-temperature characteristic oils are generally required.

If the operating temperature range is wide, synthetic fluid greases offer definite advantages. Greases are available to provide very low starting and running torque at temperatures as low as -73° C (-100° F). In certain instances, these greases perform better in this respect than oil.

An important point concerning lubricating greases is that the starting torque is not necessarily a function of the consistency or the channel properties of the grease. It appears to be more a function of the individual properties of the particular grease and is difficult to measure. Experience alone will indicate whether one grease is superior to another.

**High Temperatures**

The high temperature limit for modern grease is generally a function of the thermal and oxidation stability of the fluid and the effectiveness of the oxidation inhibitors. The graph, to the right, was prepared using military-specification greases to illustrate the thermal limitations of mineral oil, ester, silicone, and fluorinated ether greases. The limits as shown apply only to prelubricated bearings or to applications where relubrication is not possible. Where provisions have been made for relubrication, the temperature limits may be extended provided the interval between cycles is reduced accordingly.

A rule of thumb, developed from years of testing grease-lubricated bearings, indicates that grease life is halved for every 10° C (18° F) increase in temperature. For example, if a particular grease is providing 2,000 hours of life at 90° C (194° F) by raising the temperature to 100° C (212° F) reduction in life to approximately 1,000 hours would result. On the other hand, 4,000 hours could be expected by lowering the temperature to 80° C (176° F).

It becomes obvious that the reactions started by the normal reaction of lubricant with oxygen increases rapidly at higher temperatures. The lubricants undergo a series of chemical reactions, that ultimately result in the development of viscous or hard residues that interfere with the operation of the bearing.

Thermal stability, oxidation resistance, and temperature limitations must be considered when selecting greases for high-temperature applications. In non-relubricatable applications, highly refined mineral oils or chemically stable synthetic fluids are required as the oil component of greases for operation at temperatures above 121° C (250° F).

**Approximate Temperature Limits For Grease Thickeners**

Soaps	121° C	250° F
Complexes	177° C	350° F
Polyureas	177° C	350° F
Non-soap	>260° C	>500° F

**Timken Multi-Use Lithium Grease**

Soap Type:	Lithium
Consistency:	NLGI No. 1 or No. 2
Additives:	Corrosion and oxidation inhibitors
Base Oil:	Petroleum/Mineral
Base Oil Viscosity at 40° C:	145.6
Pour Point:	-18° C max.
Color:	Light Brown

**LUBRICATION GREASE TEMPERATURE RANGES**

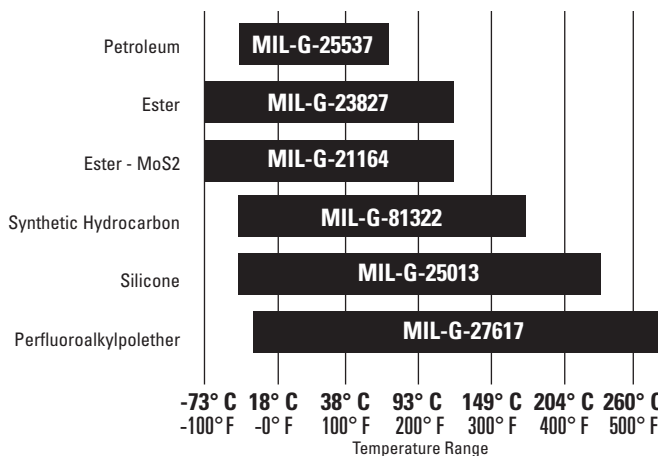



LUBRICATION AND SEALS - *continued*

Grease Compatibility Chart

	Al Complex	Ba Complex	Ca Stearate	Ca 12 Hydroxy	Ca Complex	Ca Sulfonate	Clay Non-Soap	Li Stearate	Li 12 Hydroxy	Li Complex	Polyurea	Polyurea S S
<b>Aluminum Complex</b>	Best Choice	Incompatible	Incompatible	Compatible	Incompatible	Borderline	Incompatible	Incompatible	Incompatible	Compatible	Incompatible	Compatible
<b>Timken Food Safe</b>	Best Choice	Incompatible	Incompatible	Compatible	Incompatible	Borderline	Incompatible	Incompatible	Incompatible	Compatible	Incompatible	Compatible
<b>Barium Complex</b>	Incompatible	Best Choice	Incompatible	Compatible	Incompatible	Compatible	Incompatible	Incompatible	Incompatible	Incompatible	Incompatible	Borderline
<b>Calcium Stearate</b>	Incompatible	Incompatible	Best Choice	Compatible	Incompatible	Compatible	Compatible	Compatible	Borderline	Compatible	Incompatible	Compatible
<b>Calcium 12 Hydroxy</b>	Compatible	Compatible	Incompatible	Best Choice	Borderline	Borderline	Compatible	Compatible	Compatible	Compatible	Incompatible	Compatible
<b>Calcium Complex</b>	Incompatible	Incompatible	Incompatible	Borderline	Best Choice	Incompatible	Incompatible	Incompatible	Incompatible	Compatible	Compatible	Compatible
<b>Calcium Sulfonate</b>	Borderline	Compatible	Compatible	Borderline	Incompatible	Best Choice	Incompatible	Borderline	Borderline	Compatible	Incompatible	Compatible
<b>Timken Premium Mill Timken Heavy Duty Moly</b>	Borderline	Compatible	Compatible	Borderline	Incompatible	Best Choice	Incompatible	Borderline	Borderline	Compatible	Incompatible	Compatible
<b>Clay Non-Soap</b>	Incompatible	Incompatible	Compatible	Compatible	Incompatible	Incompatible	Best Choice	Incompatible	Incompatible	Incompatible	Incompatible	Borderline
<b>Lithium Stearate</b>	Incompatible	Incompatible	Compatible	Compatible	Incompatible	Borderline	Incompatible	Best Choice	Compatible	Compatible	Incompatible	Compatible
<b>Lithium 12 Hydroxy</b>	Incompatible	Incompatible	Borderline	Compatible	Incompatible	Borderline	Incompatible	Compatible	Best Choice	Compatible	Incompatible	Compatible
<b>Lithium Complex</b>	Compatible	Incompatible	Compatible	Compatible	Compatible	Compatible	Incompatible	Compatible	Compatible	Best Choice	Incompatible	Compatible
<b>Polyurea Conventional</b>	Incompatible	Incompatible	Incompatible	Incompatible	Compatible	Compatible	Incompatible	Incompatible	Incompatible	Incompatible	Best Choice	Compatible
<b>Polyurea Shear Stable</b>	Compatible	Borderline	Compatible	Compatible	Compatible	Compatible	Borderline	Compatible	Compatible	Compatible	Compatible	Best Choice
<b>Timken Multi-Use</b>	Incompatible	Incompatible	Borderline	Compatible	Incompatible	Borderline	Incompatible	Compatible	Best Choice	Compatible	Incompatible	Compatible
<b>Timken All Purpose Timken Premium Synthetic</b>	Compatible	Incompatible	Compatible	Compatible	Compatible	Compatible	Incompatible	Compatible	Compatible	Best Choice	Incompatible	Compatible
<b>Timken High Speed</b>	Incompatible	Incompatible	Incompatible	Incompatible	Incompatible	Incompatible	Incompatible	Incompatible	Incompatible	Incompatible	Best Choice	Compatible
<b>Timken Pillow Block</b>	Compatible	Borderline	Compatible	Compatible	Compatible	Compatible	Borderline	Compatible	Compatible	Compatible	Compatible	Best Choice

**WARNING**

Mixing grease types can cause the lubricant to become ineffective, which can result in equipment failure, creating a risk of serious bodily harm.

**LUBRICATION AND SEALS - continued**

**WET CONDITIONS**

Water and moisture can be particularly conducive to bearing damage. Lubricating greases may provide a measure of protection from this contamination. Certain greases, the calcium, lithium and non-soap type, for example, are highly water-resistant. However, these greases exhibit poor rust preventative characteristics unless properly inhibited.

Sodium-soap greases emulsify with small amounts of moisture that may be present and prevent the moisture from coming in contact with the bearing surfaces. In certain applications, this characteristic may be advantageous; however, emulsions are generally considered undesirable.

Many bearing applications require lubricants with special properties or lubricants formulated specifically for certain environments, such as:

- Friction Oxidation (Fretting Corrosion).
- Chemical and Solvent Resistance.
- Food Handling.
- Quiet Running.
- Space and/or Vacuum.
- Electrical Conductivity.

For assistance with these or other areas requiring special lubricants, consult your Timken representative.

**CONTAMINATION**

**Abrasive particles**

When tapered roller bearings operate in a clean environment, the primary cause of damage is the eventual fatigue of the surfaces where rolling contact occurs. However, when particle contamination enters the bearing system, it is likely to cause damage such as bruising, which can shorten bearing life.

When dirt from the environment or metallic wear debris from some component in the application is allowed to contaminate the lubricant, wear can become the predominant cause of bearing damage. If, due to particle contamination of the lubricant, bearing wear becomes significant, changes will occur to critical bearing dimensions that could adversely affect machine operation.

Bearings operating in a contaminated lubricant exhibit a higher initial rate of wear than those running in an uncontaminated lubricant. But, with no further contaminant ingress, this wear rate quickly diminishes as the contamination particles are reduced in size as they pass through the bearing contact area during normal operation.

**Water**

Either dissolved or suspended water in lubricating oils can exert a detrimental influence on bearing fatigue life. Water can cause bearing etching that also can reduce bearing fatigue life. The exact mechanism by which water lowers fatigue life is not fully understood. It has been suggested that water enters microcracks in the bearing races that are caused by repeated stress cycles. This leads to corrosion and hydrogen embrittlement in the microcracks, reducing the time required for these cracks to propagate to an unacceptable size spall.

Water-base fluids such as water glycol and invert emulsions also have shown a reduction in bearing fatigue life. Although water from these sources is not the same as contamination, the results support the previous discussion concerning water-contaminated lubricants.

The following chart gives a good idea of the influence of water on bearing life. Based on Timken Technology tests, it was determined that water content of 0.01 percent (100 parts per million) or less, had no effect on bearing life. Greater amounts of water in the oil will reduce bearing life significantly.

**LIFE REDUCTION WITH WATER CONTAMINATION**

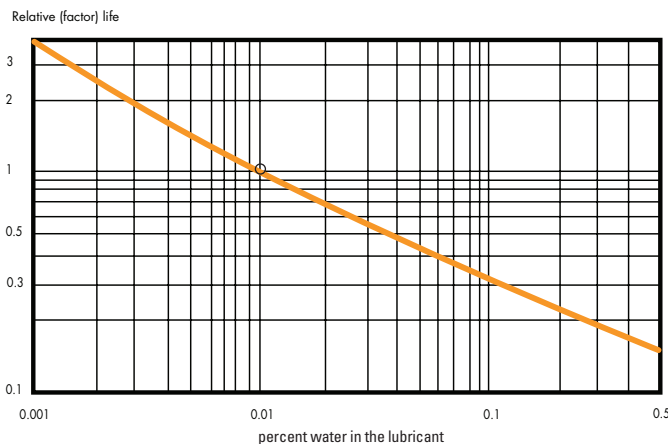

## LUBRICATION AND SEALS - *continued*

### GREASES - APPLICATIONS AND LUBRICATING METHODS

Grease lubrication is generally applicable to the following conditions, and features low-to-moderate speed applications within operating temperature limits of the grease:

- Easily confined in the housing. This is important in the food, textile and chemical industries.
- Bearing enclosure and seal design simplified.
- Improves the efficiency of external mechanical seals to give better protection to the bearing.
- Successfully used for integrally-sealed, prelubricated ball bearings.

### Advantages of prelubricated ball bearings

Prelubricated shielded and sealed bearings are extensively used with much success in applications where:

- Grease might be injurious to other parts of the mechanism.
- Cost and space limitations preclude the use of a grease filled housing.
- Housings cannot be kept free of dirt and grit, water or other contaminants.
- Relubrication is impossible or would be a hazard to satisfactory use.

Prelubricated Timken bearings are prepacked with greases that have chemical and mechanical stability and have demonstrated long life characteristics in rotating bearings. Greases are filtered several times to remove all harmful material and accurately metered so that each bearing receives the proper amount of grease.

### GREASE LUBRICATION FOR BEARING / HOUSING ASSEMBLIES

Polyurea and lithium-based greases are normally preferred for general purpose bearing lubrication and are advantageous in high moisture applications. Both greases have good water-resistant characteristics. For temperature ranges of standard greases, see chart below.

The grease must be carefully selected with regard to its consistency at operating temperature. It should not exhibit thickening, separation of oil, acid formation or hardening to any marked degree. It should be smooth, non-fibrous and entirely free from chemically active ingredients. Its melting point should be considerably higher than the operating temperature.

Frictional torque is influenced by the quantity and the quality of lubricant present. Excessive quantities of grease cause churning. This results in excessive temperatures, separation of the grease components, and breakdown in lubrication values. In normal speed applications, the housings should be kept approximately one-third to one-half full.

Only on low speed applications may the housing be entirely filled with grease. This method of lubrication is a safeguard against the entry of foreign matter, where sealing provisions are inadequate for exclusion of contaminants or moisture.

During periods of non-operation, it is often wise to completely fill the housings with grease to protect the bearing surfaces. Prior to subsequent operation, the excess grease should be removed and the proper level restored.

Applications utilizing grease lubrication should have a grease fitting and a vent at opposite ends of the housing near the top. A drain plug should be located near the bottom of the housing to allow purging of the old grease from the bearing.

Relubricate at regular intervals to prevent damage to the bearing. Relubrication intervals are difficult to determine. If plant practice or experience with other applications is not available, consult your lubricant supplier.

#### STANDARD LUBRICATION - TIMKEN BALL BEARINGS

Bearing Type	Grease Type	Grease Temperature Range
<b>Radial Bearings</b> (Double shielded and Single and Double Sealed)	Polyurea thickener Petroleum oil	-30° to +275° F
<b>Wide Inner Ring Bearings</b> (Contact Seal Types)	Polyurea thickener Petroleum oil	-30° to +275° F
<b>Wide Inner Ring Bearings</b> (Labyrinth Seal Types)	Synthetic thickener Synthetic hydrocarbon fluid	-65° to +325° F

Note: Open type bearings and single shielded types are NOT prelubricated. They have a rust preventative coating only and must be lubricated by the customer or end-user before operation.

LUBRICATION AND SEALS - continued

Multi-purpose industrial grease

These are typical of greases that can be used to lubricate many Timken bearing applications in all types of standard equipment. Special consideration should be given to applications where speed, load, temperature or environmental conditions are extreme.

Timken Multi-Use Lithium Grease	
Soap Type:	Lithium
Consistency:	NLGI No. 1 or No. 2
Additives:	Corrosion and oxidation inhibitors
Base Oil:	Petroleum/Mineral
Base Oil Viscosity at 40° C:	145.6
Pour Point:	-18° C max.
Color:	Light Brown

General purpose industrial grease should be a smooth, homogeneous and uniform, premium-quality product composed of petroleum oil, a thickener, and appropriate inhibitors. It should not contain materials that are corrosive or abrasive to tapered roller bearings. The grease should have excellent mechanical and chemical stability and should not readily emulsify with water. The grease should contain inhibitors to provide long-term protection against oxidation in high-performance applications and protect the bearings from corrosion in the presence of moisture.

The suggested base oil viscosity covers a fairly wide range. Lower viscosity products should be used in high-speed and/or lightly loaded applications to minimize heat generation and torque. Higher viscosity products should be used in moderate- to low-speed applications and under heavy loads to maximize lubricant film thickness.

Mineral grease

When conventional (mineral) greases are used, the rib speed should be limited to 5 m/s. This limit can be increased under pure radial loads up to 13 m/s provided that the bearings remain in endplay under all operating conditions. Generally, No. 2 consistency greases are used with medium- to low-viscosity base oils.

$$V_{mg} = f_{mg} \times V = f_{mg} \times \left[ \frac{\pi}{4} \times T \times (D^2 - d^2) \times 10^{-3} - \frac{M}{7.8 \times 10^{-3}} \right] \text{ (cm}^3\text{)}$$

where:

- $f_{mg}$  = factor depending on speed:  $0.3 < f_{mg} < 0.5$
- $V$  = free volume of the bearing (cm<sup>3</sup>)
- $T$  = overall bearing width (mm)
- $D$  = cup outer diameter (mm)
- $d$  = cone bore (mm)
- $M$  = bearing weight (kg)

Synthetic grease fill

The use of "low torque" greases (or synthetic greases) can be considered for rib speeds over 2,560 fpm (13 m/s), up to maximum of 4,920 fpm (25 m/s). Experience has shown that stabilized temperatures, around 15° C to 20° C (60° F to 68° F) above ambient, can be obtained at the maximum permissible speed.

The following procedures must be respected to achieve the above performance:

- Very small initial quantity of grease is applied to prevent excessive churning.
- Initial run-in period to evacuate unnecessary grease from the bearing.
- Good spindle design to retain grease around the bearings.
- Efficient sealing to protect against external contamination.

$$V_{sg} = f_{sg} \times V = f_{sg} \times \left[ \frac{\pi}{4} \times T \times (D^2 - d^2) \times 10^{-3} - \frac{M}{7.8 \times 10^{-3}} \right] \text{ (cm}^3\text{)}$$

where:

$f_{sg}$  = factor depending on speed:  $0.15 < f_{sg} < 0.3$

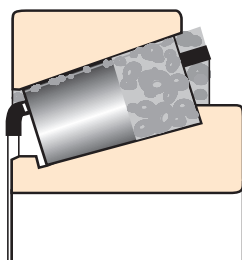
LUBRICATION AND SEALS - *continued*

Filling a bearing with synthetic grease

When using synthetic greases, the limiting factor is the "lubrication for life" concept (without re-greasing).

A normal way to fill the bearing with grease is to do it by hand before heating and fitting the components. For the cone, the free volume corresponding to the first third of the rollers, starting from their large end, is filled with grease; an additional quantity is provided below the cage. For the cup, a thin film of grease is spread all around the race.

Grease lubrication of spindle bearings is generally preferred by machine tool builders over oil circulation lubrication due to its simplicity and low heat generation. For high loads or high speeds, circulating oil is probably the most widely used method because of its capability to remove heat from the spindle.

**RE-GREASING CYCLE**

The two primary considerations that determine the re-greasing cycle on any application are operating temperature and sealing efficiency. Obviously, seal leakage will dictate frequent relubrication. Every attempt should be made to maintain seals at peak efficiency. It is generally stated that the higher the temperature, the more rapidly the grease oxidizes. Grease life is reduced by approximately half for every 10° C rise in temperature.

The higher the operating temperature, the more often the grease must be replenished. In most cases, experience in the specific application will dictate the frequency of lubrication.

**LUBRICATION AND SEALS - *continued***

Timken application specific lubricants have been developed by leveraging our knowledge of tribology and anti-friction bearings and how these two elements affect overall system performance. Timken lubricants help bearings and related components operate effectively in demanding industrial operations. High-temperature,

anti-wear and water-resistant additives offer superior protection in challenging environments. This chart is intended to provide an overview of the Timken greases available for general applications. Contact your local Timken representative for a more detailed publication on Timken lubrication solutions.

**LUBRICATION SELECTION GUIDE**

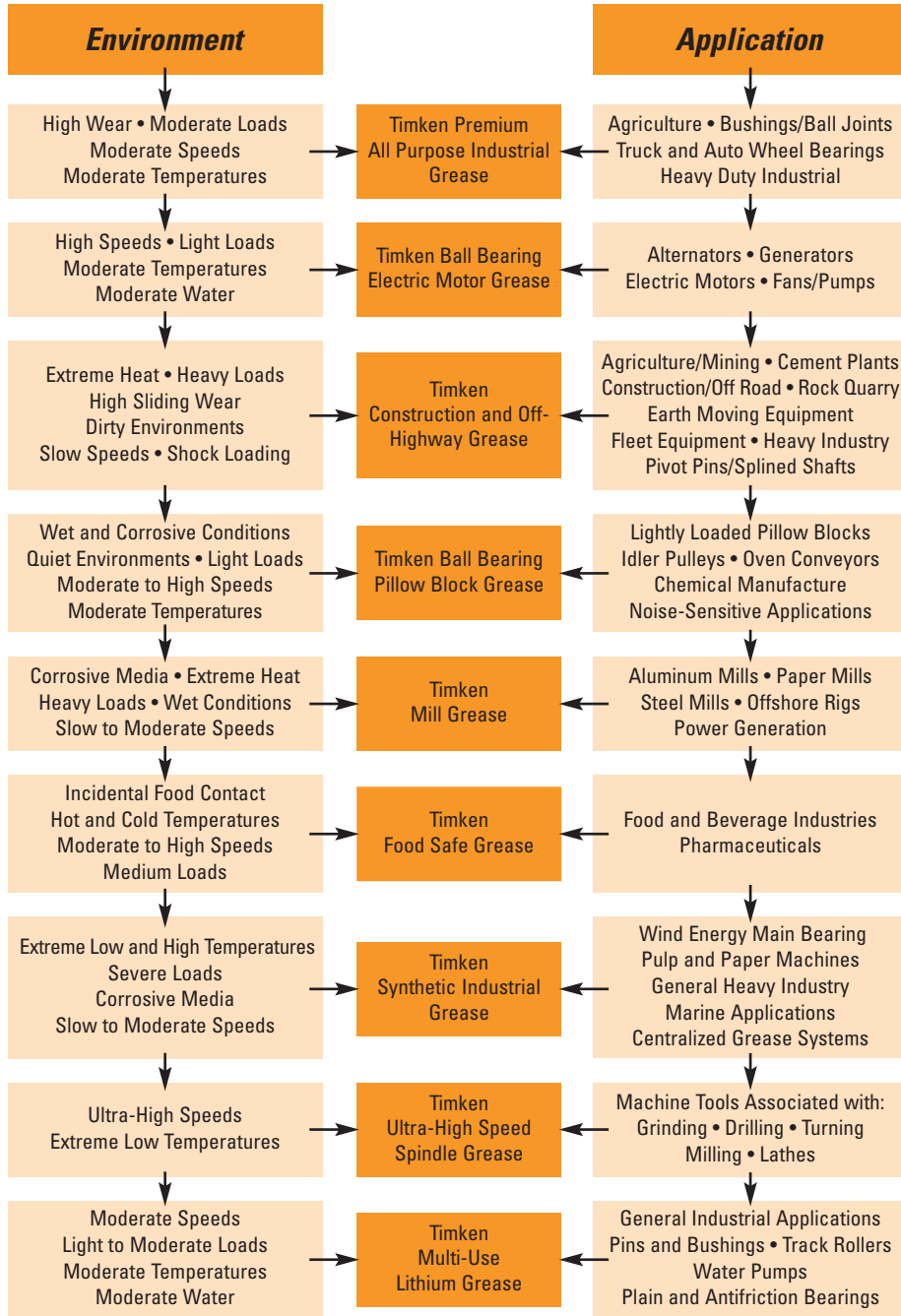

This selection guide is not intended to replace the specifications by the equipment builder.

LUBRICATION AND SEALS - *continued*

## SEALS

## SELECTING THE RIGHT SEAL

When selecting the proper seal design for any Timken bearing application, it is necessary to consider the type of lubricant, the operation environment, the speed of the application and general operating conditions.

## Shaft finish

It is important to ensure that no spiral grooves result from machining of shaft surfaces since these will tend to draw lubricant out of, or contaminant into, the bearing cavity. Plunge grinding normally produces a satisfactory surface finish.

## Grease lubrication - venting

Venting should be provided in the cavity between the two bearings when grease lubrication is used in conjunction with rubbing or non-rubbing seals. This will prevent an ingress of contamination past the seals, in the event of a pressure differential between the bearing cavity and atmosphere.

## Vertical shaft closures - oil lubrication

Lubricating vertical shaft bearings is a difficult problem. Normally, grease, oil mist or oil-air lubrication is used because of the simplicity. However, some high speed and/or heavy load applications will use circulating oil. This requires a very good sealing system and a suction pump to remove the oil from the bottom bearing position.

## NON-RUBBING SEALS

## Metal stampings

Metal stamping closures are effective in clean applications. Where environmental conditions are dirty, stampings are used in combination with other closure elements to provide an effective labyrinth against the entry of foreign matter into the bearing chamber.

The stamping shown in Fig. A-32 is effective for applications that are grease-lubricated and operate in clean conditions. The design illustrated in Fig. A-33 uses stampings on both sides of the bearing to keep the grease in close proximity to the bearing. The flinger mounted at the outer side of the bearing adds a labyrinth effect.

Stampings should be designed to provide a clearance of 0.5 to 0.6 mm (0.020 to 0.025 in.) on diameters between rotating and stationary parts. A minimum axial clearance of 3 mm (0.125 in.) should be provided.

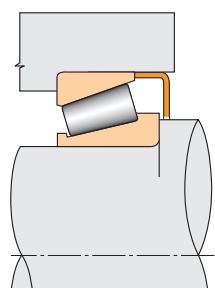

Fig. A-32  
Metal stamping.

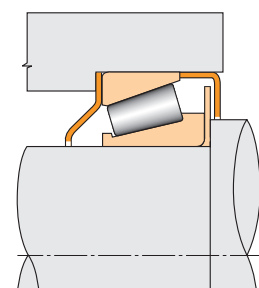

Fig. A-33  
Metal stampings.

## Machined flingers

Machined parts, along with other closure elements, can be used in place of stampings where closer clearances are desired. This results in a more efficient retention of lubricant and exclusion of foreign matter from the bearing housing. Examples are shown in Fig. A-34 and A-35.

An umbrella-shaped flinger is shown in Fig. A-35 combined with an annular groove closure. At high shaft speeds this combination effectively retains oil and keeps out dirt.

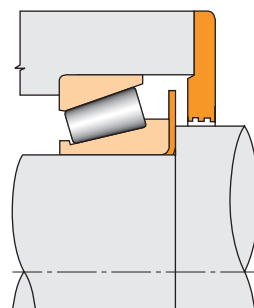

Fig. A-34  
Machined flinger combined with annular grooves.

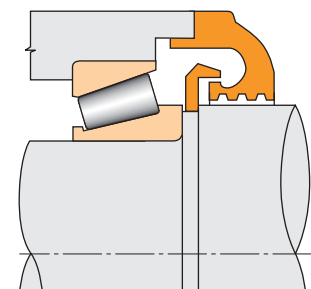

Fig. A-35  
Machined umbrella flinger combined with annular grooves.

LUBRICATION AND SEALS - continued

Annular grooves

Annular groove closures are often used with grease lubrication in place of radial lip seals where considerable grit and dust are encountered. The closure usually has several grooves machined in the bore or on the outside diameter depending on the design. They become filled with grease, which tends to harden and provide a tight closure. When used with oil, the grooves tend to interrupt the capillary action which would otherwise draw oil out of the bearing cavity. Annular grooves with a machined labyrinth effectively protect a grease-lubricated bearing when the unit is required to operate in an extremely dirty environment (Fig. A-36). This type of closure is most effective when applied with close-running clearances and the maximum possible number of grooves. Suggested dimensions are shown in Fig. A-37.

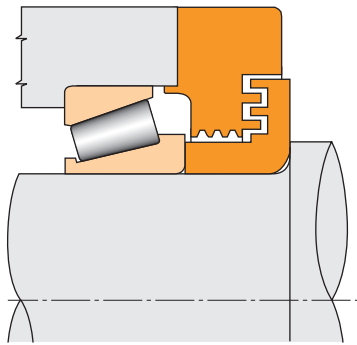
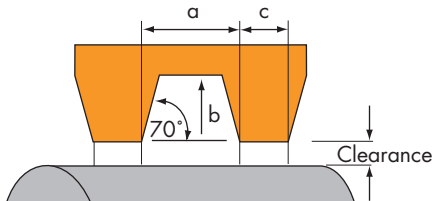

Fig. A-36  
Annular grooves combined with machined labyrinth.



dimension "a"	3.20 - 4.80 0.125 - 0.190	
dimension "b"	4.00 - 4.80 0.160 - 0.190	
dimension "c"	0.5a	
diametral clearance	0.25 - 0.40 0.010 - 0.016	for diameters to 50 mm (2 in)
	1.3 max. 0.05 max.	for diameters over 50 mm (2 in)

Fig. A-37  
Annular grooves. Suggested dimensions (mm, in.).

RUBBING SEALS

Radial lip seals

Many types and styles of radial lip seals are commercially available to satisfy different sealing requirements. In clean environments, where the primary requirement is the retention of lubricant in the bearing housing, a single lip seal with the lip pointing inward is often used. Where the critical concern is exclusion of contaminants, the lip is usually pointed outwards (Fig. A-38).

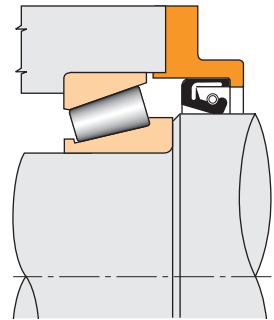

Fig. A-38  
Radial lip seals.

Lip seals are available with or without a spring-loaded lip. The spring maintains a constant pressure of the lip on the sealing surface, thereby providing a more efficient seal for a longer period of time. When environmental conditions require a seal to prevent contaminants from entering the bearing chamber as well as retaining the lubricant, a double or triple lip seal is often used. Additional flingers or shrouds should be used as primary seals where extremely dirty conditions are present so that the seal lip and sealing surface are protected to avoid rapid wear and premature seal damage (Fig. A-39).

Seal wear surfaces are normally required to have a surface finish in the order of 0.25-0.40  $\mu\text{m}$  (10-15  $\mu\text{in.}$ )  $R_a$ . For applications exposed to severe contamination, the seal wear surface should in general have a minimum surface hardness of Rockwell C-45. The seal supplier should be consulted for more specific guidance.

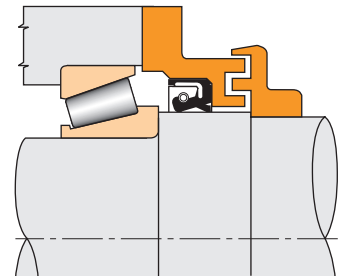
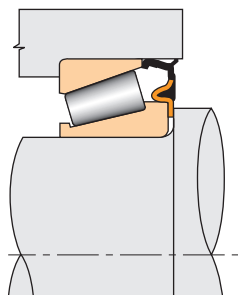

Fig. A-39  
Lip seal plus machined labyrinth.



**LUBRICATION AND SEALS - continued****“DUO FACE®-PLUS” seals**

The “DUO FACE®-PLUS” seal (Fig. A-40) has double lips that seal in the housing bore and the ground surface of the outer race front face. This eliminates the need to machine a special seal surface. The “DUO FACE®-PLUS” seal has proven successful in many different types of grease-lubricated applications. The range of Timken bearings available with “DUO FACE®-PLUS” seals is listed in this book. Also, a brochure showing application examples is available on request.



**Fig. A-40**  
DUO FACE®-PLUS seal.

**Mechanical face seals**

These are often used in extremely dirty environments where rotational speeds are low. Fig. A-42 shows one of the proprietary types of mechanical face seals available. This type of seal generally needs to run in an oil bath. Designs are also available for high-speed and other special applications.

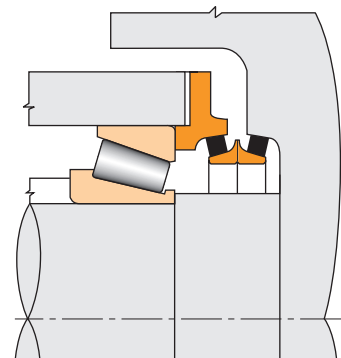

**Fig. A-42**  
Mechanical face seal for low speeds  
and contaminated environment.

**Diaphragm seals**

Diaphragm seals (Fig. A-41) are commercially available. The metallic lip is designed to be spring-loaded against the narrow face of the outer race. The type shown in Fig. A-41b has a second lip which seals against the housing.

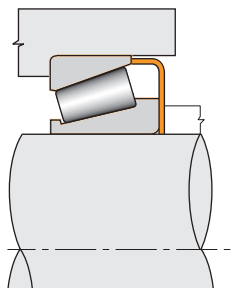

**Fig. A-41**  
Diaphragm seal.

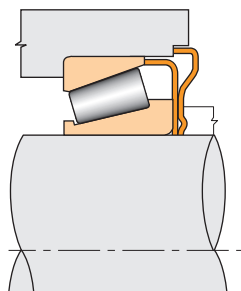

**Fig. A-41b**  
Diaphragm seal.

**V-ring seals**

V-ring seals can be used in conjunction with grease or oil lubrication. As rotational speeds increase, the lip tends to pull away from the sealing surface and act like a flinger. This seal may be used with either oil or grease lubrication (Fig A-43). Consult your V-ring seal supplier for application restrictions.

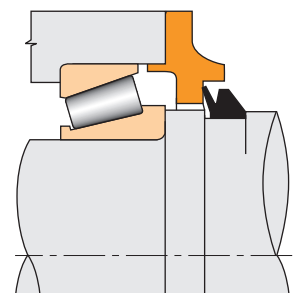

**Fig. A-43**  
V-ring seals.

LUBRICATION AND SEALS - *continued*

**BALL BEARINGS WITH SHIELDS AND SEALS**

**Shields (D-Type)**

Both K and W single-row radial types are available with one shield, designated by suffix D, or two shields, suffix DD. A shield on one side provides protection against the entrance of coarse dirt or chips and makes it possible to relubricate the bearing from the open side as shown (at right).

Double-shielded bearings are prelubricated with the correct amount of Timken suggested ball bearing grease and are designed for applications where relubrication is not required. Typical mountings are shown.

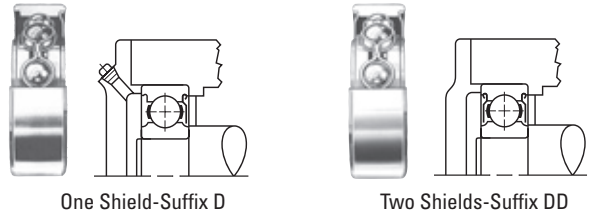

**Labyrinth or Mechani-Seals (L-Type)**

Bearings with Mechani-Seals are made in the non-filling slot type only and are available with a single seal, designated by suffix L, one seal and one shield, suffix LD, and two seals, suffix LL. These bearings have standard bores, outside diameters and outer ring widths, but the inner ring is wider than standard unshielded and shielded sizes. As illustrated, in the L and LD-Types, the inner rings are offset slightly on the side opposite the seal in order to permit clearance when the bearings are mounted in blind housings.

The Mechani-Seal was developed by Timken to provide a frictionless seal for effective grease retention and exclusion of foreign material. It consists of two "dished" steel plates. The inner member is fixed securely in the outer ring of the bearing and provides an ample grease chamber plus effective grease retention. The outer member is pressed on the outside diameter of the inner ring and rotates as a slinger to throw off contaminants. Close running clearances between the inner and outer members assure effective sealing under extremely severe conditions. This seal configuration is very effective under high speed, because it is virtually frictionless and utilizes slinger action. Mechani-Seal bearings are very popular in high-speed pneumatic tools, small electric motors, pumps, domestic appliances and similar high-speed applications. A typical mounting arrangement for the LL-Type is shown.

Wide-type radial bearings (W-LL-Type) with Mechani-Seals are designated by the prefix W and suffix LL for two seals. They are made in standard bores and outside diameters, but in widths the same as those of corresponding size double-row bearings. The extra width affords greater space for long-life factory-filtered grease and provides extra support on shafts and in housings so that locknuts and lockwashers are not needed on applications such as electric motors. A typical mounting is shown (at right).

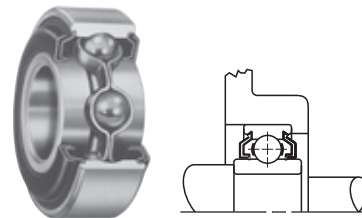
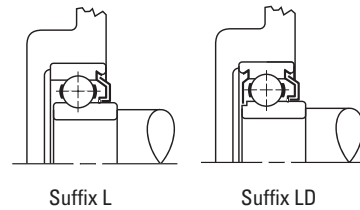

Two Mechani-Seals Suffix LL

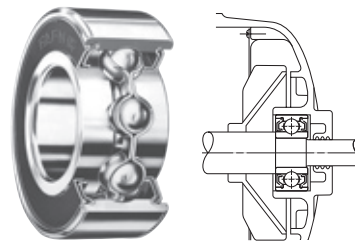

W-LL-Type Typical Mounting

## LUBRICATION AND SEALS - *continued*

### Felt Seals (T-Type)

The felt seal consists of two metal plates fixed in the outer ring of the bearing that enclose a felt washer. This felt washer, which is saturated with oil before assembly in the bearing, contacts the ground outside diameter of the inner ring to provide sealing with minimum friction drag.

Bearings with felt seals are made only in the non-filling slot type and are available with one seal (designated by the suffix T), one seal and one shield (identified by suffix TD), and two seals (suffix TT). Bore and outside diameters of these bearings are the same as standard unshielded and shielded types, but overall widths are greater. As illustrated, in the T- and TD-types, the inner rings are offset slightly on the opposite side of the seal to permit clearance when the bearings are mounted in blind housings as illustrated.

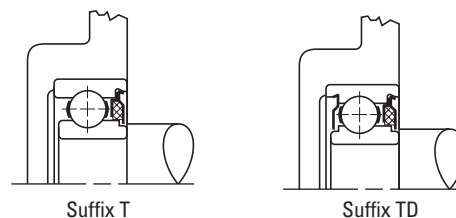

### Rubber Seals (P-Type)

Radial bearings with rubber seals having one or two seals are designated by the suffixes P and PP, respectively. With the exception of the extra-small sizes, they are dimensionally interchangeable with open-type and shielded bearings.

The P-Type design is a positive contact seal using a molded synthetic rubber. Firmly fixed to the outer ring, the seal flares outward and rides on the inner ring. The flare-out of the seal against the inner ring radius assures constant positive contact to provide an effective barrier against the entrance of contaminants or loss of lubricants.

Because they interchange dimensionally with standard single-row radial types, Timken® rubber seal bearings provide a convenient compact design.

Wide-type radial rubber seal bearings (W-PP Type) designated by prefix W and suffix PP for two seals are made with standard bores and outside diameters, but with widths the same as those as corresponding double-row bearings. This design also utilizes a molded seal.

The extra width offers a larger contact area for the shaft and housing and also provides additional space for displacement of grease under agitation.

These wide type rubber seal bearings are particularly well-suited for use by electric motor manufacturers where their advantages have helped simplify design. A typical example of motor design simplification is illustrated (right).

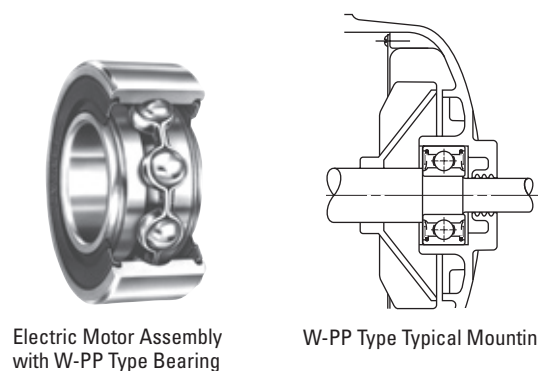
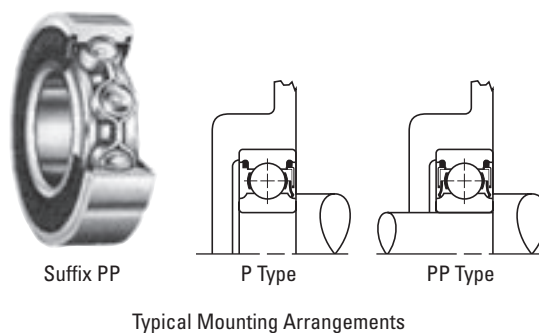

LUBRICATION AND SEALS - *continued*

**Rubber Seals (R-Type)**

One of the most advanced sealing designs introduced by Timken is the R-Type rubber seal bearing. This is a positive contact seal of three-piece construction, utilizing a synthetic rubber seal retained by two steel caps. The seal flares outward and rides or wipes on the ground land of the inner ring. In this design, the rubber sealing element is completely protected by a closely fitting outer cap or shroud, which nests tightly against the seal member following its flared-out shape at the inner ring of the outside diameter. The innermost member is crimped into a groove in the outer ring and encapsulates the seal and outside shroud. Providing firm seal contact, the back-up plate of the seal assembly has a close clearance with the outside diameter of the inner ring, preventing the seal from being pushed inward.

Laboratory tests have clearly established the superior performance of the shroud-type R-Seal. With improved lubricant retention and greater protection against contaminants, the shroud design guards the rubber seal against abrasive damage by dirt and fiber wrap, which may be prevalent in agriculture and textile applications. This seal construction also is available in standard and heavy series wide inner ring bearings.



Shroud Seal suffix RR

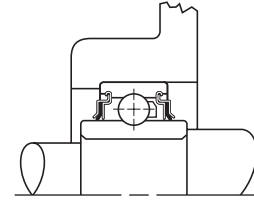

Shroud Seal suffix RR

**Tri-Ply Seals**

Tri-Ply Shroud Seal ball bearings are designed for bearing applications involving exceptionally severe contamination or abrasion environments. They are produced in many types and sizes, both in the radial and wide inner ring designs.

Each Tri-Ply seal consists of a triple-lip nitrile seal molded to a heavy metal shroud cap. All three seal lips have heavy flare-out contact with the inner ring outside diameter and provide exceptionally effective protection against the loss of lubricant and the entrance of wet or abrasive contaminants. The shroud cap, which nests closely with the outside seal lip, helps protect the rubber seal members from wrap and abrasion.

A feature of these bearings is the balanced design, consisting of deep raceways, large ball size, and extra-wide or heavy inner rings. The use of Tri-Ply bearings simplifies housing designs, and their extra inner ring width provides greater support on the shaft. These bearings are widely used on conveyors and farm machinery such as disc harrows, hillers, tomato harvesters, cotton harvesters, etc.



Tri-Ply Seals

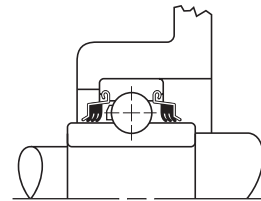

## SPEED, HEAT AND TORQUE

### SPEED RATINGS

#### RADIAL BALL BEARINGS

There is no precise method for determining the maximum speed at which a ball bearing may operate. Bearing characteristics and features of surrounding parts, shafts, housing and other component as well as basic service conditions are all variables dependent upon each other for continued satisfactory high-speed performance.

The safe operating speed of a bearing is often limited by the temperature within the bearing, which, in turn, is dependent upon the temperature surrounding the application, accuracy of bearings, shafts, housings, auxiliary parts, etc., and the type and amount of lubricant.

Radial bearings with proper internal refinements will operate at high speeds for long periods if properly installed and lubricated. Tolerance grade, cage design, and lubricant are bearing characteristics which affect speed limitations.

Bearings with ABEC 1 tolerances are generally satisfactory for normal speeds with grease or oil lubrication.

Ball bearings with ABEC 5 tolerances or better and ring-piloted composition cages lubricated with an efficient, non-churning, cooling oil-mist system have exceptional high-speed ability.

In the case of duplex mountings, as frequently used in a high-speed machine tool spindles, bearing preload and contact angle affect the permissible speeds.

The values in the accompanying table may be used as a general guide for determining the safe maximum speed of standard types of Timken ball bearings. To obtain the speed value for any bearing size with inner ring rotating, multiply the pitch diameter in millimeters (or, in the case of extra-small inch dimension bearings, the nearest millimeter equivalent) by the speed in revolutions per minute. Refer to page A164 for the most suitable bearing type, cage style, tolerance guide and type of lubrication.

For outer ring rotation of ball bearings, multiply the speed value (pitch or mean dia. in. mm x RPM of the outer ring) by the following factors before referring to the table of speed values.

#### BALL BEARING SERIES FACTOR

Extra-small (30 and S) and extra-light (9100 and M9300)	1.3
Light (200, 5200 and 7200)	1.5
Medium (300, 5300 and 7300)	1.7

Although the speed values shown in the tables on the following page are based on many years of research and accumulated data, numerous application of Timken bearings are successfully operating with speed values far in excess of those tabulated. Such applications require particular consideration of proper tolerance grade, lubrication, the effect of centrifugal force on rolling elements and other factors. For further information consult your Timken representative.

Conversely, under certain application conditions of load, temperature, contamination, etc., limiting speeds may be less than the figures shown. These values do not apply to certain special bearings, such as radial Tri-Ply series, square or hex bore bearings.

The speed capability of a bearing in any application is subject to a number of factors including:

- Temperature.
- Bearing setting or clearance.
- Lubrication.
- Bearing design.

The relative importance of each of these factors depends on the nature of the application. The effect of each factor is not isolated – each contributes in varying degrees, depending on the application and overall speed capability of the design.

An understanding of how each of these factors affects performance as speeds change is required to achieve the speed capabilities inherent in a bearing.

#### SPHERICAL AND CYLINDRICAL ROLLER BEARINGS

For Timken cylindrical and spherical roller bearings, the thermal speed ratings are listed in the bearing tables. These values have been determined by balancing the heat generated within the bearing with the heat dissipated from the bearing. In calculating these numbers, the following assumptions have been made:

- The radial load is five percent of the static load rating.
- For oil, it is assumed to be in a bath with the fill to the middle of the lowest rolling element. For grease it is assumed a 30 percent bearing cavity fill.
- The oil viscosity is assumed to be 12 cSt (ISO VG32) operated at 70° C, (158° F) and the grease base oil viscosity is assumed to be 22 cSt operated at 70° C (158° F). The bearing and its components are at 70° C and the bearing environment is at 20° C (68° F).
- The housing and shaft are steel or cast iron.
- The bearing rotational axis is horizontal.
- The outer ring is stationary and the inner ring is rotating.
- The bearing radial internal clearance complies with class normal and standard fits are used.
- The bearing does not contain seals.
- The bearing does not experience misalignment or axial load.

The thermal speed ratings are for reference only and can be considerably lower or higher depending on your application. Consult your Timken representative for more accurate information regarding a bearing's speed limitations in your application.

RADIAL BALL BEARINGS									
d <sub>m</sub> X N VALUES (d <sub>m</sub> * IN MILLIMETERS X RPM)									
Bearing Type / Series	Cage Type	ABEC 1		ABEC 3			ABEC 5 and 7 Circulating Oil <sup>(1)</sup>		
		Grease	Oil <sup>(1)</sup>	Grease	Oil <sup>(1)</sup>	Grease	Grease	Oil <sup>(1)</sup>	Oil Mist
<b>BALL BEARINGS</b>									
<b>SINGLE-ROW</b>									
Non-Filling Slot 9300K, 9100K 200K, 300K, XLS, and variations	Ball Piloted Molded Nylon (PRB)	250,000	300,000	250,000	300,000	—	300,000	300,000	300,000
	Pressed Steel, Brass	300,000	350,000	300,000	350,000	—	350,000	400,000	450,000
	Ring Piloted Molded Reinforced Nylon (PRC) Composition (CR)	350,000	400,000	350,000	450,000	—	400,000	550,000	650,000
Filling Slot 200W and variations 300W and variations	Ball Piloted Molded Nylon (PRB)	250,000	250,000	—	—	—	—	—	—
	Pressed Steel	250,000	300,000	—	—	—	—	—	—
Angular Contact 7200WN 7300WN Angular Contact- Extra precision 2M9300WI, 2M200WI, 2M300WI, 2M9100WI, 2MM9300WI, 2MM9100, 2MM200WI, 2MM300WI	Ball Piloted Pressed Steel, Molded Nylon (PRB)	200,000	300,000	300,000	350,000	—	—	—	—
	Ring Piloted Brass (MBR), Ball Piloted Br (MBR)	300,000	400,000	—	—	—	—	—	—
	Ring Piloted Molded Reinforced Nylon (PRC)	350,000	400,000	350,000	400,000	—	—	—	—
	Ring Piloted Composition (CR) or (PRC)	350,000	400,000	750,000	1,000,000	1,200,000	1,000,000	1,400,000	1,700,000
<b>DOUBLE-ROW</b>									
5200 5300	Ball Piloted Molded Nylon (PRB), Pressed Steel	250,000	300,000	—	—	—	—	—	—
	Ball Piloted Brass (BR)								

\* Bore + O.D.  
2

<sup>(1)</sup> For oil bath lubrication, oil level should be maintained covering between 1/3 to 1/2 up from the bottom of the lowest ball.

**Note:** Single or double normal contact (P or PP) sealed bearings should not exceed 300,000 PDN. Consult your Timken representative for limiting speed of RR or Tri-Ply sealed bearings.

SPEED, HEAT AND TORQUE - continued

TAPERED ROLLER BEARINGS

The usual measure of the speed of a tapered roller bearing is the circumferential velocity at the midpoint of the inner race large end rib (Fig. A-44). This may be calculated as:

Rib speed:

$$V_r = \frac{\pi D_m n}{60000} \text{ (m/s)}$$

$$= \frac{\pi D_m n}{12} \text{ (ft/min)}$$

where:

- $D_m$  = Mean inner race large rib diameter mm, in.
- $n$  = Bearing speed rev/min

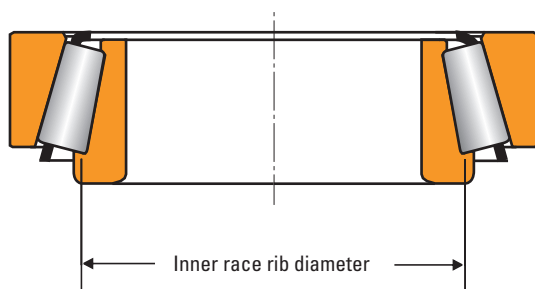
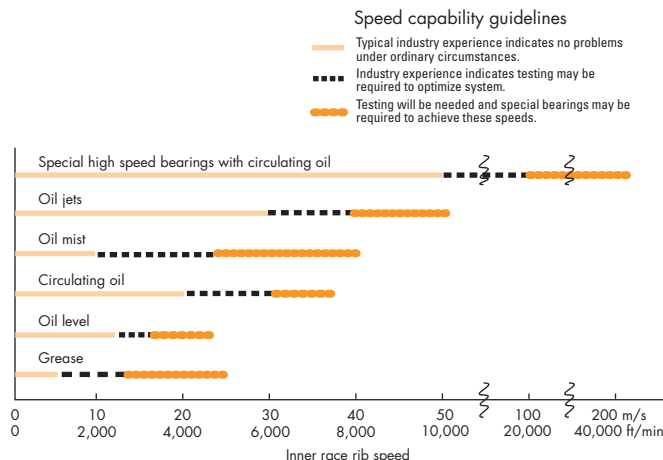

**Fig. A-44**  
Cone rib diameter. The inner race rib diameter may be scaled from a print.

The mean large rib diameter at the midpoint of the roller end contact can be scaled from a drawing of the bearing, if available, or this diameter can be determined by consulting your Timken representative. The inner cone mean large rib diameter can be approximated by taking 99 percent of larger rib O.D.

DN values (the product of the inner race bore in mm and the speed in rev/min) are often used as a measure of bearing speed by other bearing manufacturers. There is no direct relationship between the rib speed of a tapered roller bearing and DN value because of the wide variation in bearing cross sectional thickness. However, for rough approximation, one meter per second rib speed is about equal to 16,000 DN for average section bearings. One foot per minute is equal to approximately 80 DN.

SPEED CAPABILITY GUIDELINES FOR VARIOUS TYPES OF LUBRICATION SYSTEMS



**Fig. A-45**

Fig. A-45 is a summary of guidelines relating to speed and temperature based on customer experience, customer tests and research conducted by The Timken Company. Consult your Timken representative with questions regarding high-speed capability.



SPEED, HEAT AND TORQUE - *continued*

## OPERATING TEMPERATURES

### TEMPERATURE LIMITATIONS

Bearing equilibrium temperature is not simply a question of speed. It is also dependent on the heat generation rate of all contributing heat sources, nature of the heat flow between sources, and heat dissipation rate of the system. Seals, gears, clutches, and oil supply temperature affect bearing operating temperature.

Heat dissipation rate is governed by such factors as type of lubrication system, materials and masses of the shaft and housing and intimacy of contact with the bearing, and surface area and character of the fluid both inside and outside the housing.

Temperature of the outer surface of the housing is not an accurate indication of bearing temperature. The inner ring temperature is often greater than the outer ring temperature and both are usually greater than the outer surface of the housing. There are temperature gradients within the bearing with the temperature of the internal parts usually being greater than the outer surfaces. Although the temperature of the outer ring O.D. or the inner ring I.D., or the oil outlet is often used as an indicator of bearing temperature, it should be recognized that these are generally not the highest bearing temperatures.

During transient conditions, such as at startup, bearing temperatures will often peak and then reduce to a lower level. This is due to the thermal changes taking place between the bearing, shaft and housing causing variations in setting and internal loading. Also, a new bearing will usually generate more heat until it runs in.

The allowable operating temperature depends on:

- Equipment requirements
- Lubrication limitations
- Bearing material limitations
- Reliability requirements

Each factor is an area of increasing concern as operating temperatures rise.

The equipment designer must decide how operating temperature will affect the performance of the equipment being designed. Precision machine tools, for example, can be very sensitive to thermal expansions. In many cases it is important that the temperature rise over ambient be minimized and held to 20 to 25° C (36 to 45° F) for some precision spindles.

Most industrial equipment can operate satisfactorily with considerably higher temperature rises. Thermal ratings on gear drives, for example, are based on 93° C (200° F).

Some equipment such as plastic calendars and gas turbine engines operate continuously at temperatures well above 100° C (212° F).

Standard bearing steels cannot maintain the desired minimum hot hardness of 58 HRC much above 135° C (275° F).

Standard Timken spherical roller bearings are dimensionally stabilized up to 200° C. Upon request, the bearings can be ordered with dimensional stabilization up to 250° C (S2 suffix) or 300° C (S3 suffix). Consult your Timken representative for availability in specific part numbers.

Standard Timken cylindrical roller bearings are dimensionally stabilized up to 150° C. Upon request, the bearings can be ordered

with dimensional stabilization up to 200° C (S1 suffix), 250° C (S2 suffix) or 300° C (S3 suffix).

Dimensional stability of Timken ball bearings is achieved by tempering the hardened steel until any further growth by transformation of austenite to martensite is balanced by shrinkage from tempering martensite. This balance is never perfect, and some size change will always occur, the amount depending upon the operating time and temperature of the bearings and the composition of and heat treatment of the steel. The ABMA definition for stabilized rings and balls permits a change of less than .0001 inch per inch after exposure to a temperature of 300° F for 2,500 hours. Rings and balls used at elevated temperatures are defined as stable by ABMA where there is a size change of less than .00015 inch per inch after 1,500 hours exposure at temperatures of 450°, 600° and 800° F.

Above this, special high-temperature steels are used by Timken.

Timken CBS 600™ steel should be considered for temperatures between 150 to 230° C (300 to 450° F) and Timken CBS 1000M™ steel should be used for temperatures above 230° C (450° F). Also, CBS 600 and CBS 1000M have increased resistance to scoring - important in very high-speed applications. Consult your Timken representative for availability of S1, S2, S3 suffixes or high-temperature steels in specific part numbers and applications.

Although bearings can operate satisfactorily at higher temperatures, an upper temperature limit of 80 to 95° C (176 to 203° F) is usually more practical for small, high volume equipment where prototype testing is possible. Higher operating temperatures increase the risk of damage from some unforeseen transient condition. If prototype testing is not practical, an upper design limit of 80° C (176° F) is appropriate unless prior experience on similar equipment suggests otherwise.

History on some machines operating at higher temperatures, such as high-speed rolling mills, offers good background data for establishing limits on new similar machines.

Obviously none of the above examples of equipment, lubricant or bearing materials limitations are single point limitations but rather areas of gradually increasing concern. It is the responsibility of the equipment designer to weigh all relevant factors and make the final determination of what operating temperature is satisfactory for his particular machine.

Suggested materials for use in rings, balls and rollers at various operating temperatures are listed together with data on chemical composition, hardness and dimensional stability. A temperature of 427° C (800° F) is generally the top limit for successful bearing operation using steels. Above 427° C (800° F), or below where lubricant is not permitted, cast or wrought cobalt alloys are generally used. Although chosen primarily for their good retention of physical properties, they also possess good oxidation resistance at elevated temperatures.

Suggested materials for cages, shields, and seals are tabulated on page A168 with their temperature capabilities.



**SPEED, HEAT AND TORQUE - continued****Other Considerations**

Until now, temperature limitation has been discussed in reference to metallurgical considerations. However, installations which operate at high temperatures for extended periods may lose the quality of shaft and housing fits. Carefully machined and heat-treated shafts and housings will minimize trouble from this source. In some applications the internal clearance of bearings may be partially absorbed. For example, during the first few seconds of rotation a massive housing may keep the outer race cooler than the inner race and rolling elements even if the housing is already at some elevated temperature and, also, during heat soakback when rotation stops heat may flow back to the bearing along the shaft. If, while stationary, the effects of heat soakback more than removes the radial internal clearance, radial brinell of the races may occur and the bearing will be rough during subsequent rotation. Bearings with extra internal looseness may be required to compensate for the above conditions.

**HEAT GENERATION AND DISSIPATION**

One of the major benefits of oil-lubricated systems is that the heat generated by the bearings is carried away by the circulating oil and dissipated through the system.

**Heat generation**

Under normal operating conditions, most of the torque and heat generated by the bearing is due to the elastohydrodynamic losses at the roller/race contacts.

The following equation is used to calculate the heat generated by the bearing:

$$Q_{gen} = k_4 n M$$

$$M = k_1 G_1 (n\mu)^{0.62} (P_{eq})^{0.3}$$

where:

- $Q_{gen}$  = generated heat (W or Btu/min)
- $M$  = running torque N.m or lbf-in.
- $n$  = rotational speed (RPM)
- $G_1$  = geometry factor from bearing data tables
- $\mu$  = viscosity at operating temperature (cP)
- $P_{eq}$  = equivalent dynamic load (N or lbf)
- $k_1$  = bearing torque constant
  - =  $2.56 \times 10^{-6}$  for  $M$  in N-m
  - =  $3.54 \times 10^{-5}$  for  $M$  in lbf-in.

**Heat dissipation**

The heat dissipation rate of a bearing system is affected by many factors. The modes of heat transfer need to be considered. Major heat transfer modes in most systems are conduction through the housing walls, convection at the inside and outside surfaces of the housing, and convection by the circulating lubricant. In many applications, overall heat dissipation can be divided into two categories: Heat removed by circulating oil and heat removed through the housing.

**Heat dissipation by circulating oil**

Heat dissipated by a circulating oil system is:

$$Q_{oil} = k_5 f (\theta_o - \theta_i)$$

If a circulating lubricant other than petroleum oil is used, the heat carried away by that lubricant will be:

$$Q_{oil} = k_6 C_p \rho f (\theta_o - \theta_i)$$

The following factors apply to the heat generation and dissipation equations listed on this page.

$k_4$	Dimensional factor to calculate heat generation rate $k_4 = 0.105$ for $Q_{gen}$ in W when $M$ in N-m $= 6.73 \times 10^{-4}$ for $Q_{gen}$ in Btu/min when $M$ in lbf-in.	
$k_5$	Dimensional factor to calculate heat carried away by a petroleum oil $k_5 = 28$ for $Q_{oil}$ in W when $f$ in L/min and $\theta$ in °C $= 0.42$ for $Q_{oil}$ in Btu/min when $f$ in U.S. pt/min and $\theta$ in °F	
$k_6$	Dimensional factor to calculate heat carried away by a circulating fluid $k_6 = 1.67 \times 10^{-5}$ for $Q_{oil}$ in W $= 1.67 \times 10^{-2}$ for $Q_{oil}$ in Btu/min	
$Q_{oil}$	Heat dissipation rate of circulating oil	W, Btu/min
$\theta_i$	Oil inlet temperature	°C, °F
$\theta_o$	Oil outlet temperature	°C, °F
$C_p$	Specific heat of lubricant	J/(kg x °C), Btu/(lb x °F)
$f$	Lubricant flow rate	L/min, U.S. pt/min
$\rho$	Lubricant density	kg/m <sup>3</sup> , lb/ft <sup>3</sup>

SPEED, HEAT AND TORQUE - *continued*

These tables provide standard operating temperatures for common bearing component materials. They should be used for reference purposes only. Other bearing component materials are available on request. Contact your Timken representative for further information.

OPERATING TEMPERATURES FOR BEARING COMPONENT MATERIALS

RINGS, BALLS AND ROLLERS SINGLE-ROW													
Material	Approximate Chemical Analysis-%	Temp. °F	Hardness HRC	Operating Temperature									
				-100° F -73° C	-65° F	0° F -17° C	100° F 38° C	200° F 93° C	250° F	300° F 149° C	400° F 204° C	500° F 260° C	600° F 316° C
Low alloy carbon-chromium bearing steels. 52100 and others per ASTM A295	1C 0.5-1.5Cr 0.35Mn	70	60	STANDARD DIMENSIONAL STABILIZATION <0.0001 in/in dimensional change in 2,500 hours at 212° F. Good oxidation resistance.									
Low alloy carbon-chromium bearing steels. 52100 and others per ASTM A295	1C 0.5-1.5Cr 0.35Mn	70 350 450	58 56 54	Heat stabilized per FS136 <.0001 in/in dimensional change in 2,500 hours at 300° F. When given a stabilizing heat treatment, A295 steel is suitable for many applications in the 350-450° F range; however, it is not as stable dimensionally as it is at temperatures below 350° F. If utmost stability is required, use materials in the 600° F group below.									
Deep hardening steels for heavy sections per ASTM A485	1C 1-1.8Cr 1-1.5 Mn .06Si	70 450 600	58 55 52	As heat treated and tempered, it is stabilized, <.0001 in/in dimensional change in 2500 HR at 300° F (149° C).									
Carburizing steels per ASTM A534 (a) low alloy 4118 (b) 8620 (c) high nickel 3310	.2C, .5Cr, .80Mn, .12Mo .2C, .5Cr, .80 Mn, .20 Mo, .55Ni .10C, 1.60Cr, .50Mn, 3.50Ni	70	58	4118, 8620 steel frequently used to achieve extra ductility in inner rings for locking device bearings. 3310 and others used for extra thick section rings.									
Corrosion Resistant 440C stainless steel per ASTM A756	1C 18Cr	70	58	Excellent corrosion resistance.									
Corrosion Resistant 440C stainless steel per ASTM A756	1C 18Cr	70 450 600	58 55 52	As heat stabilized for maximum hardness at high temperatures (FS238). Good oxidation resistance at higher temperatures. Note load capacity drops off more rapidly at higher temperatures than M50 shown below, which should be considered if loads are high. <.0001 in/in dimensional change in 1,200 hours.									
M-50 Medium High Speed	4 Cr. 4 Mo 1V 0.8C	70 450 600	60 59 57	Recommended where stable high hardness at elevated temperature is required. <.0001 in/in dimensional change in 1,200 hours at 600° F.									

Dimensional stability data shown above is the permanent metallurgical growth and/or shrinkage only. Thermal expansion effects are not included. Bearings have been made of special material for operation at temperatures above 800° F. Consult your Timken representative regarding the application.

Note: ASTM A295 bearing steels are suitable for many applications up to 250° F but are not as dimensionally stable as they are at temperatures below 212° F.

OPERATING TEMPERATURES FOR BEARING COMPONENT MATERIALS

CAGES, SHIELDS AND SEALS										
	-65° F -54° C	0° F -17° C	100° F 38° C	200° F 93° C	300° F 149° C	400° F 204° C	500° F 260° C	600° F 316° C	700° F 371° C	800° F 427° C
<b>CAGES</b>										
Molded 6/6 Nylon (PRB)	[Bar chart showing temperature range from 0°F to 200°F]									
Molded 6/6 Fiberglass reinforced Nylon (PRC)	[Bar chart showing temperature range from 0°F to 300°F]									
Phenolic Resin Laminate	[Bar chart showing temperature range from 0°F to 400°F]									
Low Carbon Pressed Steel	[Bar chart showing temperature range from 0°F to 500°F]									
Pressed Stainless Steel	[Bar chart showing temperature range from 0°F to 600°F]									
Machined Brass	[Bar chart showing temperature range from 0°F to 600°F]									
Machined Iron-Silicone	[Bar chart showing temperature range from 0°F to 600°F]									
Machined Steel	[Bar chart showing temperature range from 0°F to 800°F]									
<b>SHIELDS</b>										
Low Carbon Steel	[Bar chart showing temperature range from 0°F to 400°F]									
Stainless Steel	[Bar chart showing temperature range from 0°F to 600°F]									
Nylon	[Bar chart showing temperature range from 0°F to 200°F]									
<b>SEALS</b>										
Buna N	[Bar chart showing temperature range from 0°F to 300°F]									
Polyacrylic	[Bar chart showing temperature range from 0°F to 400°F]									
Fluoroelastomer	[Bar chart showing temperature range from 0°F to 500°F]									
Stabilized TFE Fluorocarbon*	[Bar chart showing temperature range from 0°F to 600°F]									
TFE Fluorocarbon* (with glass fabric)	[Bar chart showing temperature range from 0°F to 600°F]									

\* Limited life above these temperatures.

SPEED, HEAT AND TORQUE - continued

TORQUE

TAPERED ROLLER BEARINGS

Running torque-M

The rotational resistance of a rolling bearing is dependent on load, speed, lubrication conditions and bearing internal characteristics.

The following formulas yield approximations to values of bearing running torque. The formulas apply to bearings lubricated by oil. For bearings lubricated by grease or oil mist, torque is usually lower, although for grease lubrication this depends on amount and consistency of the grease. The formulas also assume the bearing running torque has stabilized after an initial period referred to as "running-in."

Single-row tapered roller bearing

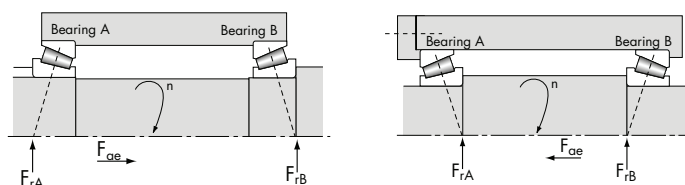

Design (external thrust,  $F_{ae}$ , onto bearing A)

Thrust condition	Net bearing thrust load	
$\frac{0.47 F_{rA}}{K_A} \leq \frac{0.47 F_{rB}}{K_B} + F_{ae}$	$F_{aA} = \frac{0.47 F_{rB}}{K_B} + F_{ae}$ $F_{aB} = \frac{0.47 F_{rB}}{K_B}$	$M = k_1 G_1 (n\mu)^{0.62} \left( \frac{f_1 F_r}{K} \right)^{0.3}$ $n_{min} = \frac{k_2}{G_2\mu} \left( \frac{f_2 F_r}{K} \right)^{2/3}$
$\frac{0.47 F_{rA}}{K_A} > \frac{0.47 F_{rB}}{K_B} + F_{ae}$	$F_{aA} = \frac{0.47 F_{rA}}{K_A}$ $F_{aB} = \frac{0.47 F_{rA}}{K_A} - F_{ae}$	

NOTE: The torque equations will be underestimated if operating speed,  $n$ , is less than  $n_{min}$ . For values of  $f_1$  and  $f_2$ , refer to figure A-46 on page A171.

**Double-row tapered roller bearing**

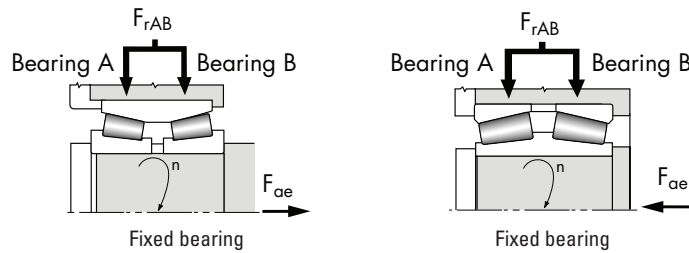

Design (external thrust,  $F_{ae}$ , onto bearing A)

**Fixed position**

Load condition	Radial load on each row $F_r$	
$F_{ae} > \frac{0.47 F_{rAB}}{K_A}$	Bearing B is unloaded $F_{rA} = F_{rAB}$ $F_{aA} = F_{ae}$	$M = k_1 G_1 (n\mu)^{0.62} \left( \frac{f_1 F_{rAB}}{K} \right)^{0.3}$ $n_{min} = \frac{k_2}{G_2\mu} \left( \frac{f_2 F_{rAB}}{K} \right)^{2/3}$
$F_{ae} \leq \frac{0.47 F_{rAB}}{K_A}$	$F_{rA} = \frac{F_{rAB}}{2} + 1.06 K F_{ae}$ $F_{rB} = \frac{F_{rAB}}{2} - 1.06 K F_{ae}$	$M = k_1 G_1 (n\mu)^{0.62} \left( \frac{0.060}{K} \right)^{0.3} (F_{rA}^{0.3} + F_{rB}^{0.3})$ $n_{minA} = \frac{k_2}{G_2\mu} \left( \frac{1.78F_{rA}}{K} \right)^{2/3}; \quad n_{minB} = \frac{k_2}{G_2\mu} \left( \frac{1.78F_{rB}}{K} \right)^{2/3}$

**Floating position**

$$M = 2 k_1 G_1 (n\mu)^{0.62} \left( \frac{0.030 F_{rC}}{K} \right)^{0.3}$$

$$n_{min} = \frac{k_2}{G_2\mu} \left( \frac{0.890 F_r}{K} \right)^{2/3}$$

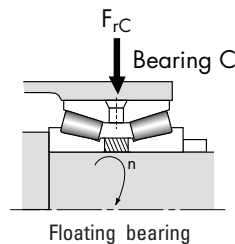

NOTE: The torque equations will be underestimated if operating speed,  $n$ , is less than  $n_{min}$ . For values of  $f_1$  and  $f_2$ , refer to figure A-46 on page A171.

- $M$  = running torque, N.m (lbf-in.)
- $F_r$  = radial load, N (lbf)
- $G_1$  = geometry factor from bearing data tables
- $G_2$  = geometry factor from bearing data tables
- $K$  = K-factor
- $n$  = speed of rotation, rev/min
- $k_1$  =  $2.56 \times 10^{-6}$  (metric) or  $3.54 \times 10^{-5}$  (inch)
- $k_2$  = 625 (metric) or 1700 (inch)
- $\mu$  = lubricant dynamic viscosity at operating temperature centipoise  
For grease, use the base oil viscosity.
- $f_1$  = combined load factor, see chart on A171
- $f_2$  = combined load factor, see chart on A171

SPEED, HEAT AND TORQUE - continued

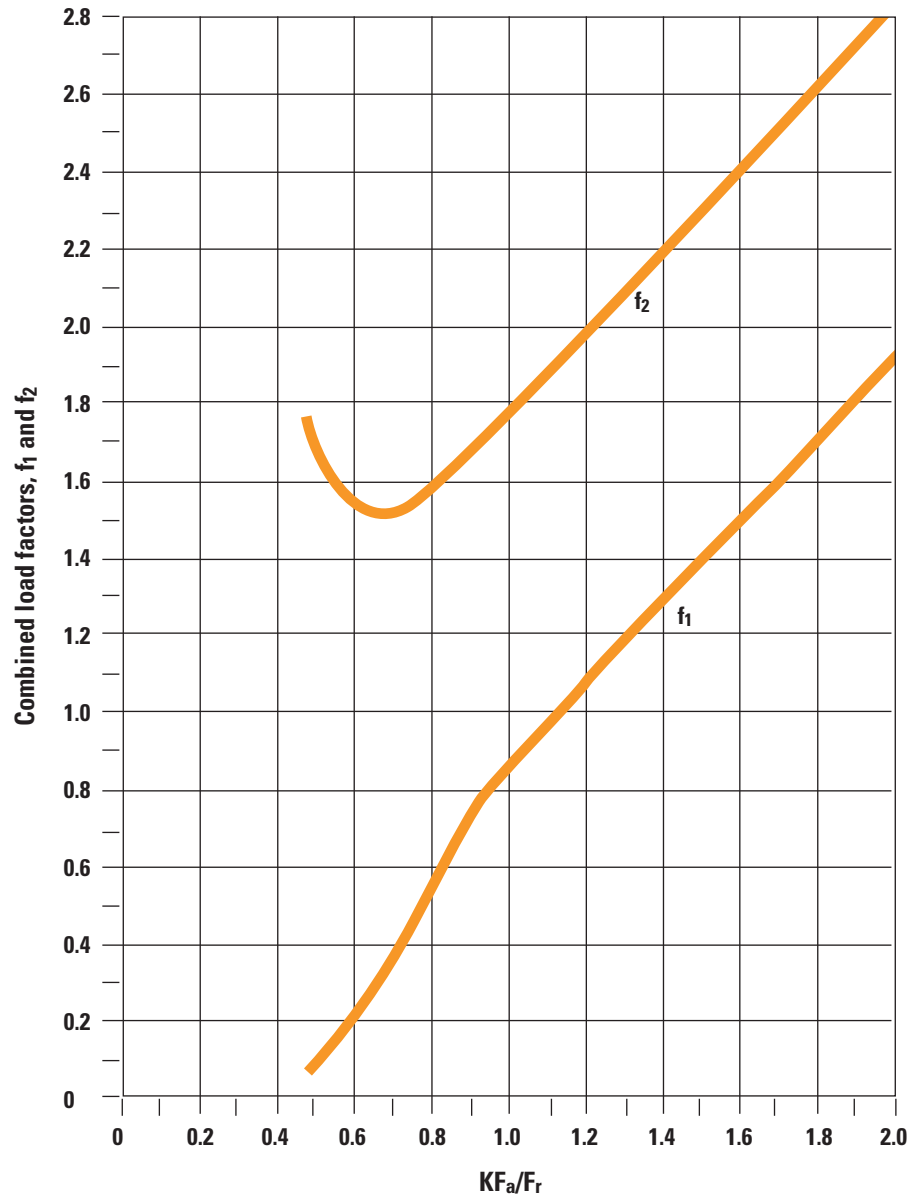

DETERMINATION OF COMBINED LOAD FACTORS  $f_1$  AND  $f_2$

Load condition	$f_1$ and $f_2$
$KF_a/F_r > 2.0$	$f_1 = KF_a/F_r$ $f_2 = f_1 + 0.8$
$0.47 \leq KF_a/F_r \leq 2.0$	use graph above
$KF_a/F_r < 0.47$	$f_1 = 0.06$ $f_2 = 1.78$

Fig. A-46

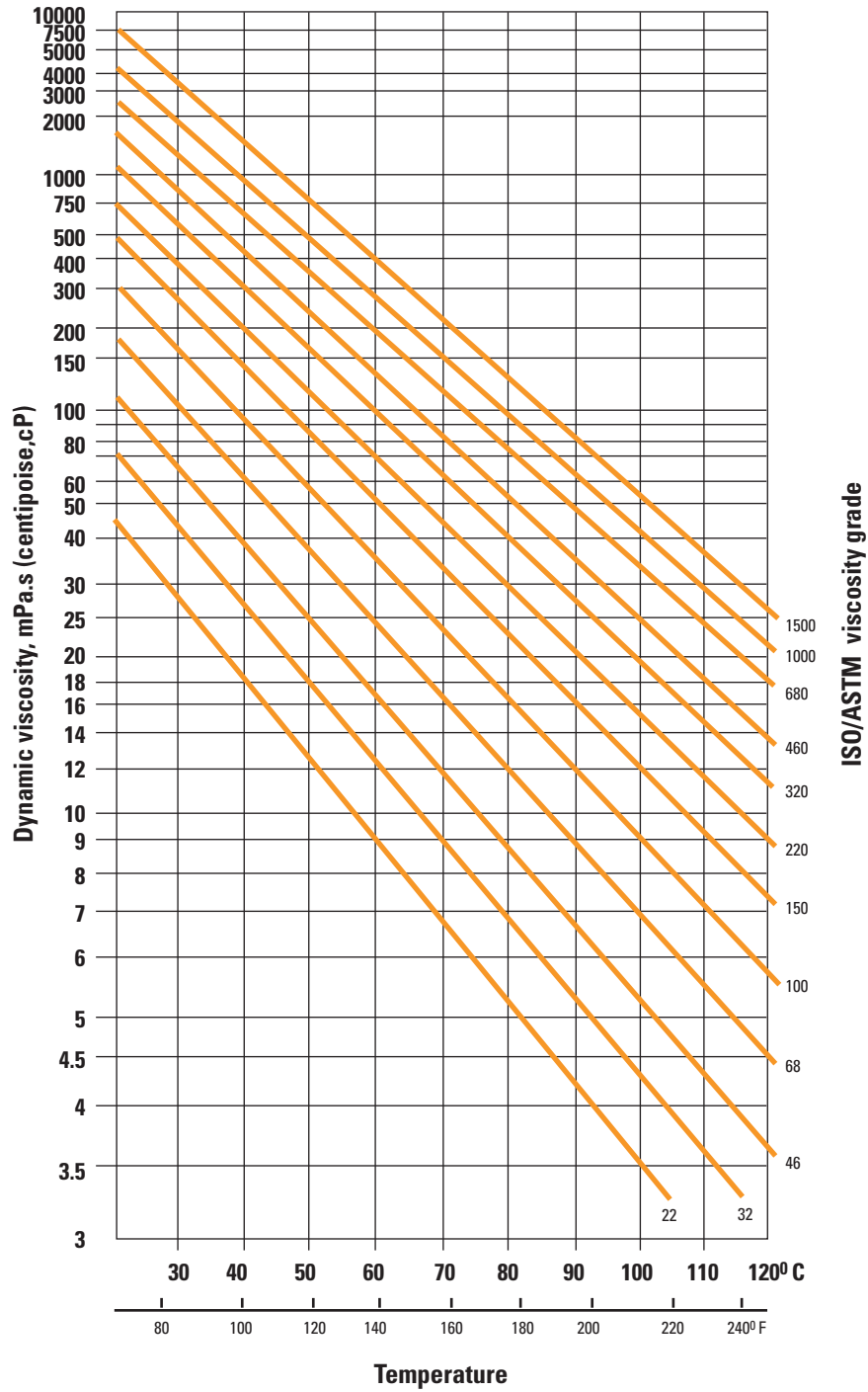

Viscosities in mPa.s (centipoise, cP) for ISO/ASTM industrial fluid lubricant grade designations. Assumes: Viscosity Index 90; Specific Gravity 0.875 at 40° C.

Fig. A-47



**SPEED, HEAT AND TORQUE - continued**

**NEEDLE ROLLER BEARINGS**

Empirical torque equations for radial and thrust needle bearings were developed by Timken:

$$M = d_m (4.5 \times 10^{-7} v^{0.3} n^{0.6} + 0.12F_r^{0.4})$$

Testing also showed that full complement radial needle roller bearings operate at 1.5 to 2 times the torque determined for caged radial needle roller bearings. Similarly, the running torque of thrust needle roller bearings is given:

$$M = 4.5 \times 10^{-7} v^{0.3} n^{0.6} d_m + 0.016F_a l$$

In both equations, the mean diameter  $d_m$  is the average of the bore and O.D. Of the bearings, while the length ( $l$ ) in the thrust bearing torque equation can be approximated using the bearing's radial section (e.g.,  $l = 1/2 [E_a - E_b]$ ). Finally, note that the viscosity is in units of centistokes, while that for tapered roller bearings was in centipoise. A typical conversion factor for mineral oil is  $1 \text{ cSt} = 0.875 \text{ cp}$ .

Both of the aforementioned equations were determined for circulating oil lubrication systems. For grease lubrication, the viscosity of the base oil should be used to estimate the running torque.

**CYLINDRICAL AND SPHERICAL ROLLER AND BALL BEARINGS**

The torque equations for cylindrical and spherical roller bearings are given as follows, where the coefficients are based on series and found in the following table:

$$M = \begin{cases} f_1 F_\beta d_m + 10^{-7} f_0 (v \cdot n)^{2/3} d_m^3 & \text{if } (v \cdot n) \geq 2000 \\ f_1 F_\beta d_m + 160 \times 10^{-7} f_0 d_m^3 & \text{if } (v \cdot n) < 2000 \end{cases}$$

Again, note that the viscosity is in units of centistokes. The load term ( $F_\beta$ ) is dependent on bearing type as follows:

Radial Ball: 
$$F_\beta = \max \left( \begin{array}{c} 0.9F_a \cot \alpha - 0.1F_r \\ \text{or} \\ F_r \end{array} \right)$$

Radial Cylindrical and Spherical Roller: 
$$F_\beta = \max \left( \begin{array}{c} 0.8F_a \cot \alpha \\ \text{or} \\ F_r \end{array} \right)$$

Thrust Ball and Cylindrical and Spherical Roller: 
$$F_\beta = F_a$$

COEFFICIENTS FOR THE TORQUE EQUATION			
Bearing Type	Dimension Series	$f_0$	$f_1$
Single-row deep groove ball bearings	18	1.7	0.00010
	28	1.7	0.00010
	38	1.7	0.00010
	19	1.7	0.00015
	39	1.7	0.00015
	00	1.7	0.00015
	10	1.7	0.00015
	02	2	0.00020
	03	2.3	0.00020
	04	2.3	0.00020
Single-row angular contact ball bearings $22^\circ < \alpha \leq 45^\circ$	02	2	0.00025
	03	3	0.00035
Double-row or paired single-row angular contact ball bearings	32	5	0.00035
	33	7	0.00035
Gothic Arch ball bearings	02	2	0.00037
	03	3	0.00037
Single-row cylindrical roller bearings with cage	10	2	0.00020
	02	2	0.00030
	22	3	0.00040
	03	2	0.00035
	23	4	0.00040
04	2	0.00040	
Single-row cylindrical roller bearings full complement	18	5	0.00055
	29	6	0.00055
	30	7	0.00055
	22	8	0.00055
	23	12	0.00055
Spherical Roller Bearings	39	4.5	0.00017
	30	4.5	0.00017
	40	6.5	0.00027
	31	5.5	0.00027
	41	7	0.00049
	22	4	0.00019
	32	6	0.00036
	03	3.5	0.00019
23	4.5	0.00030	
Double-row cylindrical roller bearings full complement	48	9	0.00055
	49	11	0.00055
	50	13	0.00055
Thrust cylindrical roller bearings	11	3	0.00150
	12	4	0.00150
Thrust spherical roller bearings	92	2.5	0.00023
	93	2.5	0.00023
	94	3	0.00030

# CONVERSION TABLES

TO CONVERT FROM	TO	MULTIPLY BY	
<b>ACCELERATION</b>			
foot/second <sup>2</sup>	meter/second <sup>2</sup>	m/s <sup>2</sup>	0.3048
inch/second <sup>2</sup>	meter/second <sup>2</sup>	m/s <sup>2</sup>	0.0254
<b>AREA</b>			
foot <sup>2</sup>	meter <sup>2</sup>	m <sup>2</sup>	0.09290304
inch <sup>2</sup>	meter <sup>2</sup>	m <sup>2</sup>	0.00064516
inch <sup>2</sup>	millimeter <sup>2</sup>	mm <sup>2</sup>	645.16
yard <sup>2</sup>	meter <sup>2</sup>	m <sup>2</sup>	0.836127
mile <sup>2</sup> (U.S. statute)	meter <sup>2</sup>	m <sup>2</sup>	2589988
<b>BENDING MOMENT OR TORQUE</b>			
dyne-centimeter	newton-meter	N • m	0.000001
kilogram-force-meter	newton-meter	N • m	9.806650
pound-force-inch	newton-meter	N • m	0.1129848
pound-force-foot	newton-meter	N • m	1.355818
<b>ENERGY</b>			
BTU (International Table)	joule	J	1055.056
foot-pound-force	joule	J	1.355818
kilowatt-hour	megajoule	MJ	3.6
<b>FORCE</b>			
kilogram-force	newton	N	9.806650
kilopound-force	newton	N	9.806650
pound-force (lbf)	newton	N	4.448222
<b>LENGTH</b>			
fathom	meter	m	1.8288
foot	meter	m	0.3048
inch	millimeter	mm	25.4
microinch	micrometer	µm	0.0254
micron (µm)	millimeter	mm	0.0010
mile (U.S. statute)	meter	m	1609.344
yard	meter	m	0.9144
nautical mile	meter	m	1852
<b>MASS</b>			
kilogram-force-second <sup>2</sup> /meter(mass)	kilogram	kg	9.806650
kilogram-mass	kilogram	kg	1.0
pound-mass (lbm avoirdupois)	kilogram	kg	0.4535924
ton (long, 2240 lbm)	kilogram	kg	1016.047
ton (short, 2000 lbm)	kilogram	kg	907.1847
tonne	kilogram	kg	1000.000
<b>POWER</b>			
BTU (International Table)/hour	watt	W	0.293071
BTU (International Table)/minute	watt	W	17.58427
horsepower (550 ft lbf/s)	kilowatt	kW	0.745700
BTU (Thermochemical)/minute	watt	W	17.57250
<b>PRESSURE OR STRESS (FORCE/AREA)</b>			
newton/meter <sup>2</sup>	pascal	Pa	1.0000
kilogram-force/centimeter <sup>2</sup>	pascal	Pa	98066.50
kilogram-force/meter <sup>2</sup>	pascal	Pa	9.806650
kilogram-force/millimeter <sup>2</sup>	pascal	Pa	9806650
pound-force/foot <sup>2</sup>	pascal	Pa	47.88026
pound-force/inch <sup>2</sup> (psi)	megapascal	MPa	0.006894757
<b>TEMPERATURE</b>			
degree Celsius	kelvin	k	t <sub>k</sub> = t <sub>c</sub> + 273.15
degree Fahrenheit	kelvin	k	k = 5/9 (t <sub>f</sub> + 459.67)
degree Fahrenheit	degree Celsius	°C	t <sub>c</sub> = 5/9 (t <sub>f</sub> - 32)
<b>VELOCITY</b>			
foot/minute	meter/second	m/s	0.00508
0.3048 foot/second	meter/second	meter/second	m/s
inch/second	meter/second	m/s	0.0254
kilometer/hour	meter/second	m/s	0.27778
mile/hour (U.S. statute)	meter/second	m/s	0.44704
mile/hour (U.S. statute)	kilometer/hour	km/h	1.609344
<b>VOLUME</b>			
foot <sup>3</sup>	meter <sup>3</sup>	m <sup>3</sup>	0.02831685
gallon (U.S. liquid)	liter	l	3.785412
liter	meter <sup>3</sup>	m <sup>3</sup>	0.001
inch <sup>3</sup>	meter <sup>3</sup>	m <sup>3</sup>	0.00001638706
inch <sup>3</sup>	centimeter <sup>3</sup>	cm <sup>3</sup>	16.38706
inch <sup>3</sup>	millimeter <sup>3</sup>	mm <sup>3</sup>	16387.06
ounce (U.S. fluid)	centimeter <sup>3</sup>	cm <sup>3</sup>	29.57353
yard <sup>3</sup>	meter <sup>3</sup>	m <sup>3</sup>	0.7645549

VISCOSITY CONVERSION TABLE			
SUS	R'	E	cSt
Saybolt (sec.)	Redwood (sec.)	Engler (deg.)	Centistokes
35	32.2	1.18	2.7
40	36.2	1.32	4.3
45	40.6	1.46	5.9
50	44.9	1.60	7.4
55	49.1	1.75	8.9
60	53.5	1.88	10.4
65	57.9	2.02	11.8
70	62.3	2.15	13.1
75	67.6	2.31	14.5
80	71.0	2.42	15.8
85	75.1	2.55	17.0
90	79.6	2.68	18.2
95	84.2	2.81	19.4
100	88.4	2.95	20.6
110	97.1	3.21	23.0
120	105.9	3.49	25.0
130	114.8	3.77	27.5
140	123.6	4.04	29.8
150	132.4	4.32	32.1
160	141.1	4.59	34.3
170	150.0	4.88	36.5
180	158.8	5.15	38.8
190	167.5	5.44	41.0
200	176.4	5.72	43.2
220	194.0	6.28	47.5
240	212	6.85	51.9
260	229	7.38	56.5
280	247	7.95	60.5
300	265	8.51	64.9
325	287	9.24	70.3
350	309	9.95	75.8
375	331	10.7	81.2
400	353	11.4	86.8
425	375	12.1	92.0
450	397	12.8	97.4
475	419	13.5	103
500	441	14.2	108
550	485	15.6	119
600	529	17.0	130
650	573	18.5	141
700	617	19.9	152
750	661	21.3	163
800	705	22.7	173
850	749	24.2	184
900	793	25.6	195
950	837	27.0	206
1000	882	28.4	217
1200	1058	34.1	260
1400	1234	39.8	302
1600	1411	45.5	347
1800	1587	51	390
2000	1763	57	433
2500	2204	71	542
3000	2646	85	650
3500	3087	99	758
4000	3526	114	867
4500	3967	128	974
5000	4408	142	1082
5500	4849	156	1150
6000	5290	170	1300
6500	5730	185	1400
7000	6171	199	1510
7500	6612	213	1630
8000	7053	227	1740
8500	7494	242	1850
9000	7934	256	1960
9500	8375	270	2070
10000	8816	284	2200



CONVERSION TABLES - continued

INCHES TO MILLIMETERS — UNITS

inches	0	1	2	3	4	5	6	7	8	9	
0	0.0000	0.000	25.400	50.800	76.200	101.600	127.000	152.400	177.800	203.200	228.600
1/16	0.0625	1.588	26.988	52.388	77.788	103.188	128.588	153.988	179.388	204.788	230.188
1/8	0.1250	3.175	28.575	53.975	79.375	104.775	130.175	155.575	180.975	206.375	231.775
3/16	0.1875	4.763	30.162	55.562	80.962	106.362	131.762	157.162	182.562	207.962	233.362
1/4	0.2500	6.350	31.750	57.150	82.550	107.950	133.350	158.750	184.150	209.550	234.950
5/16	0.3125	7.938	33.338	58.738	84.138	109.538	134.938	160.338	185.735	211.138	236.538
3/8	0.3750	9.525	34.925	60.325	85.725	111.125	136.525	161.925	187.325	212.725	238.125
7/16	0.4375	11.112	36.512	61.912	87.312	112.712	138.112	163.512	188.912	214.312	239.712
1/2	0.5000	12.700	38.100	63.500	88.900	114.300	139.700	165.100	190.500	215.900	241.300
9/16	0.5625	14.288	39.688	65.088	90.488	115.888	141.288	166.688	192.088	217.488	242.888
5/8	0.6250	15.875	41.275	66.675	92.075	117.475	142.875	168.275	193.675	219.075	244.475
11/16	0.6875	17.462	42.862	68.262	93.662	119.062	144.462	169.862	195.262	220.662	246.062
3/4	0.7500	19.050	44.450	69.850	95.250	120.650	146.050	171.450	196.850	222.250	247.650
13/16	0.8125	20.638	46.038	71.438	96.838	122.238	147.638	173.038	198.438	223.838	249.238
7/8	0.8750	22.225	47.625	73.025	98.425	123.825	149.225	174.625	200.025	225.425	250.825
15/16	0.9375	23.812	49.212	74.612	100.012	125.412	150.812	176.212	201.612	227.012	252.412

inches	10	11	12	13	14	15	
0	0.0000	254.000	279.400	304.800	330.200	355.600	381.000
1/16	0.0625	255.588	280.988	306.388	331.788	357.188	382.588
1/8	0.1250	257.175	282.575	307.975	333.375	358.775	384.175
3/16	0.1875	258.762	284.162	309.562	334.962	360.362	385.762
1/4	0.2500	260.350	285.750	311.150	336.550	361.950	387.350
5/16	0.3125	261.938	287.338	312.738	338.138	363.538	388.938
3/8	0.3750	263.525	288.925	314.325	339.725	365.125	390.525
7/16	0.4375	265.112	290.512	315.912	341.312	366.712	392.112
1/2	0.5000	266.700	292.100	317.500	342.900	368.300	393.700
9/16	0.5625	268.288	293.688	319.088	344.488	369.888	395.288
5/8	0.6250	269.875	295.275	320.675	346.075	371.475	396.875
11/16	0.6875	271.462	296.862	322.262	347.662	373.062	398.462
3/4	0.7500	273.050	298.450	323.850	349.250	374.650	400.050
13/16	0.8125	274.638	300.038	325.438	350.838	376.238	401.638
7/8	0.8750	276.225	301.625	327.025	352.425	377.825	403.225
15/16	0.9375	277.812	303.212	328.612	354.012	379.412	404.812

B.S.I. Norm No. 350 } 1 inch = 25.400 mm  
 A.S.A. Norm No. B48.1 } (exact)  
 DIN 4890, 1 mm =  $\frac{1}{25.4}$  inches

UNITS

inches	10
0	— 254
1	25.4 279.4
2	50.8 304.8
3	76.2 330.2
4	101.6 355.6
5	127 381
6	152.4 406.4
7	177.8 431.8
8	203.2 457.2
9	228.6 482.6

FRACTIONS

1/10"		1/100"		1/1000"		1/10000"	
inch	mm	inches	mm	inches	mm	inches	mm
0.1	2.54	0.01	0.254	0.001	0.0254	0.0001	0.00254
0.2	5.08	0.02	0.508	0.002	0.0508	0.0002	0.00508
0.3	7.62	0.03	0.762	0.003	0.0762	0.0003	0.00762
0.4	10.16	0.04	1.016	0.004	0.1016	0.0004	0.01016
0.5	12.70	0.05	1.270	0.005	0.1270	0.0005	0.01270
0.6	15.24	0.06	1.524	0.006	0.1524	0.0006	0.01524
0.7	17.78	0.07	1.778	0.007	0.1778	0.0007	0.01778
0.8	20.32	0.08	2.032	0.008	0.2032	0.0008	0.02032
0.9	22.86	0.09	2.286	0.009	0.2286	0.0009	0.02286

MILLIMETERS TO INCHES — UNITS

mm	10	20	30	40	50	60	70	80	90	
0	—	0.39370	0.78740	1.18110	1.57480	1.96850	2.36220	2.75591	3.14961	3.54331
1	0.03937	0.43307	0.82677	1.22047	1.61417	2.00787	2.40157	2.79528	3.18898	3.58268
2	0.07874	0.47244	0.86614	1.25984	1.65354	2.04724	2.44094	2.83465	3.22835	3.62205
3	0.11811	0.51181	0.90551	1.29921	1.69291	2.08661	2.48031	2.87402	3.26772	3.66142
4	0.15748	0.55118	0.94488	1.33858	1.73228	2.12598	2.51969	2.91339	3.30709	3.70079
5	0.19685	0.59055	0.98425	1.37795	1.77165	2.16535	2.55906	2.95276	3.34646	3.74016
6	0.23622	0.62992	1.02362	1.41732	1.71102	2.20472	2.59843	2.99213	3.38583	3.77953
7	0.27559	0.66929	1.06299	1.45669	1.85039	2.24409	2.63780	3.03150	3.42520	3.81890
8	0.31496	0.70866	1.10236	1.49606	1.88976	2.28346	2.67717	3.07087	3.46457	3.85827
9	0.35433	0.74803	1.14173	1.53543	1.92913	2.32283	2.71654	3.11024	3.50394	3.89764

FRACTIONS

mm	1/10 mm		1/100 mm		1/1000 mm	
	mm	inches	mm	inches	mm	inches
0.1	0.00394	0.01	0.00039	0.001	0.000039	0.000039
0.2	0.00787	0.02	0.00079	0.002	0.000079	0.000079
0.3	0.01181	0.03	0.00118	0.003	0.000118	0.000118
0.4	0.01575	0.04	0.00157	0.004	0.000157	0.000157
0.5	0.01969	0.05	0.00197	0.005	0.000197	0.000197
0.6	0.02362	0.06	0.00236	0.006	0.000236	0.000236
0.7	0.02756	0.07	0.00276	0.007	0.000276	0.000276
0.8	0.03150	0.08	0.00315	0.008	0.000315	0.000315
0.9	0.03543	0.09	0.00354	0.009	0.000354	0.000354

CONVERSION TABLES - continued

STEEL HARDNESS NUMBERS*													
APPROXIMATE HARDNESS CONVERSION NUMBERS FOR STEEL, BASED ON ROCKWELL C													
Rockwell C-Scale Hardness Number	Diamond Pyramid Hardness Number Vickers	Brinell Hardness Number 10 mm Ball 3000 kg Load			Rockwell Hardness Number			Rockwell Superficial Hardness Number Superficial Brale Penetrator			Shore Scleroscope Hardness Number	Tensile Strength (approx.) 1000 psi	Rockwell C-Scale Hardness Number
		Standard Ball	Hultgren Ball	Tungsten Carbide Ball	A-Scale 60 kg Load Brale Penetrator	B-Scale 100 kg Load 1/16" Dia. Ball	D-Scale 100 kg Brale Penetrator	15-N Scale 15 kg Load	30-N Scale 30 kg Load	45-N Scale 45 kg Load			
68	940	—	—	—	85.6	—	76.9	93.2	84.4	75.4	97	—	68
67	900	—	—	—	85	—	76.1	92.9	83.6	74.2	95	—	67
66	865	—	—	—	84.5	—	75.4	92.5	82.8	73.3	92	—	66
65	832	—	—	739	83.9	—	74.5	92.2	81.9	72	91	—	65
64	800	—	—	722	83.4	—	73.8	91.8	81.1	71	88	—	64
63	772	—	—	705	82.8	—	73	91.4	80.1	69.9	87	—	63
62	746	—	—	688	82.3	—	72.2	91.1	79.3	68.8	85	—	62
61	720	—	—	670	81.8	—	71.5	90.7	78.4	67.7	83	—	61
60	697	—	613	654	81.2	—	70.7	90.2	77.5	66.6	81	—	60
59	674	—	599	634	80.7	—	69.9	89.8	76.6	65.5	80	326	59
58	653	—	587	615	80.1	—	69.2	89.3	75.7	64.3	78	315	58
57	633	—	575	595	79.6	—	68.5	88.9	74.8	63.2	76	305	57
56	613	—	561	577	79	—	67.7	88.3	73.9	62	75	295	56
55	595	—	546	560	78.5	—	66.9	87.9	73	60.9	74	287	55
54	577	—	534	543	78	—	66.1	87.4	72	59.8	72	278	54
53	560	—	519	525	77.4	—	65.4	86.9	71.2	58.6	71	269	53
52	544	500	508	512	76.8	—	64.6	86.4	70.2	57.4	69	262	52
51	528	487	494	496	76.3	—	63.8	85.9	69.4	56.1	68	253	51
50	513	475	481	481	75.9	—	63.1	85.5	68.5	55	67	245	50
49	498	464	469	469	75.2	—	62.1	85	67.6	53.8	66	239	49
48	484	451	455	455	74.7	—	61.4	84.5	66.7	52.5	64	232	48
47	471	442	443	443	74.1	—	60.8	83.9	65.8	51.4	63	225	47
46	458	432	432	432	73.6	—	60	83.5	64.8	50.3	62	219	46
45	446	421	421	421	73.1	—	59.2	83	64	49	60	212	45
44	434	409	409	409	72.5	—	58.5	82.5	63.1	47.8	58	206	44
43	423	400	400	400	72	—	57.7	82	62.2	46.7	57	201	43
42	412	390	390	390	71.5	—	56.9	81.5	61.3	45.5	56	196	42
41	402	381	381	381	70.9	—	56.2	80.9	60.4	44.3	55	191	41
40	392	371	371	371	70.4	—	55.4	80.4	59.5	43.1	54	186	40
39	382	362	362	362	69.9	—	54.6	79.9	58.6	41.9	52	181	39
38	372	353	353	353	69.4	—	53.8	79.4	57.7	40.8	51	176	38
37	363	344	344	344	68.9	—	53.1	78.8	56.8	39.6	50	172	37
36	354	336	336	336	68.4	(109)	52.3	78.3	55.9	38.4	49	168	36
35	345	327	327	327	67.9	(108.5)	51.5	77.7	55	37.2	48	163	35
34	336	319	319	319	67.4	(108)	50.8	77.2	54.2	36.1	47	159	34
33	327	311	311	311	66.8	(107.5)	50	76.6	53.3	34.9	46	154	33
32	318	301	301	301	66.3	(107)	49.2	76.1	52.1	33.7	44	150	32
31	310	294	294	294	65.8	(106)	48.4	75.6	51.3	32.5	43	146	31
30	302	286	286	286	65.3	(105.5)	47.7	75	50.4	31.3	42	142	30
29	294	279	279	279	64.7	(104.5)	47	74.5	49.5	30.1	41	138	29
28	286	271	271	271	64.3	(104)	46.1	73.9	48.6	28.9	41	134	28
27	279	264	264	264	63.8	(103)	45.2	73.3	47.7	27.8	40	131	27
26	272	258	258	258	63.3	(102.5)	44.6	72.8	46.8	26.7	38	127	26
25	266	253	253	253	62.8	(101.5)	43.8	72.2	45.9	25.5	38	124	25
24	260	247	247	247	62.4	(101)	43.1	71.6	45	24.3	37	121	24
23	254	243	243	243	62	100	42.1	71	44	23.1	36	118	23
22	248	237	237	237	61.5	99	41.6	70.5	43.2	22	35	115	22
21	243	231	231	231	61	98.5	40.9	69.9	42.3	20.7	35	113	21
20	238	226	226	226	60.5	97.8	40.1	69.4	41.5	19.6	34	110	20

\* Source ASTM