

# DRAWN CUP NEEDLE ROLLER BEARINGS

## Full Complement Bearings



Full Complement  
Mechanically Retained Rollers



Full Complement  
Closed End

## INTRODUCTION

Before selecting individual bearings the Engineering section of this catalog should be reviewed for detailed information concerning:

- bearing type selection
- bearing life and reliability
- definition of load ratings
- life and load relationships
- effect of raceway hardness
- example of life calculation
- lubrication
- limiting speeds
- shaft design
- housing design

In addition to these general considerations, review the material which follows when selecting drawn cup bearings.

## IDENTIFICATION

The prefix letter or letters in the bearing designation for Drawn Cup (DC) bearings denote whether the bearings are made to inch or metric nominal dimensions as well as their major construction features.

For example, a bearing with metric nominal dimensions is indicated by the code letter **F** or **HK** having open ends and letters **BK** for closed ends, in the prefix. Letters in the prefix other than **HK**, **BK** or **F** indicate a bearing of inch nominal dimensions.

Most sizes of inch bearings are available with either a full complement of rollers or caged rollers. Metric bearings are available with caged rollers as a standard. The use of caged rollers in inch bearings is indicated by the prefix code letter **J**.

Inch bearings are available in either of two radial cross sections. The larger cross section is indicated by the prefix code letter **H**. Absence of the letter **H** indicates the smaller radial cross section.

These major features of dimension and construction are summarized in Table 1.

In addition, there can be other identifying letters which cover special modifications.

Table 1

### Identifying Letters

	Prefix Letters in Bearing Designation		
	Inch Series		Metric Series
	Smaller Roller	Larger Roller	Regular Roller
Full Complement Mechanically Retained	<b>B</b>	<b>BH</b>	—
Caged	<b>J</b>	<b>JH</b>	<b>HK,FJ</b>

Other prefix letters in inch bearings denoting major construction features are:

- M** – closed end style
- P** – open end (finger) cage
- T** – single seal
- TT** – double seal
- G** – extra-precision

Since the entire identification code in the bearing designation may not appear on the bearing itself, the manufacturers' parts list or another reliable source should always be consulted when ordering bearings for service or field replacement to make certain that the correct bearing with the correct lubricant is used.

## BORE/O.D. COMPARISON, STANDARD AND LARGER ROLLERS

As noted above, many sizes of inch drawn cup needle roller bearings are made in two bore/o.d. series, differing primarily in the roller diameter for a given bearing bore. Both series are very compact and offer very low cross section profiles compared with other rolling bearing types. The more compact series with the smaller rollers offers optimum performance with minimum feasible outside diameter for a given shaft size. The series with larger rollers, designated by the letter prefix **H**, offers more capacity and better performance at higher speeds for the same given shaft size.

# DRAWN CUP NEEDLE ROLLER BEARINGS

## FULL COMPLEMENT BEARING CONSTRUCTION

The full complement drawn cup bearing combines maximum capacity and low cost with the advantages of the drawn outer ring. The inward turned lips of the cup are used to mechanically retain the full complement of needle rollers to provide positive radial retention of the rollers even though it may be necessary to remove the shaft repeatedly during the servicing of the mechanism employing the bearing.

Full Complement Mechanically Retained Rollers

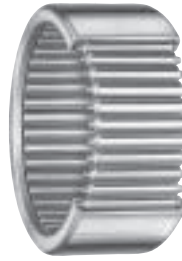

Full Complement Closed End



## CAGED BEARING CONSTRUCTION

Caged drawn cup bearings have a steel cage which provides inward retention of the needle rollers. The design provides maximum cage strength consistent with the long life requirements.

Bearings with other cage designs are also available. Bearings with reinforced plastic cages are for use where operating conditions permit.

Caged, Cage Retained Rollers



Caged, Closed End



Caged Bearing Construction

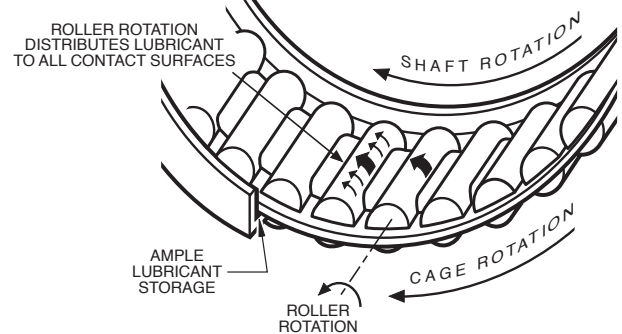

## SEALED BEARINGS

Drawn cup caged needle roller bearings are offered with integral seals. The tables of dimensions on pages 378-379 indicate those sizes available with lip contact seals which limit the bearing operating temperature between -25°F and +225°F (-30°C and +110°C). The seal lip design achieves a light and constant contact with the shaft throughout the range of mounting bearing clearances thereby ensuring positive sealing and low frictional drag.

Sealed drawn cup bearings are intended to retain grease or non-pressurized oil within a bearing while also preventing contaminants entering the raceway area. These seals are not intended to withstand a pressure differential exceeding 2 psi (14kPa).

Details of shaft design for sealed bearings are given in the Engineering section of this catalog.

The standard lip contact seals are compatible with common lubricating oils and petroleum based fuels, but they are adversely affected by certain fire-resistant hydraulic fluids and most common solvents.

Caged, Double Sealed

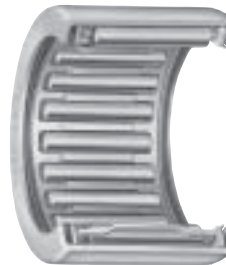

# DRAWN CUP NEEDLE ROLLER BEARINGS

## DESCRIPTION OF TABULAR DATA

The opportunities for interchange of different types and series are seen in the tables of dimensions starting on page 364, where bearings with the same bore, o.d. and width are listed on the same line in the table. (Sealed DC bearings are shown on pages 378-379 and extraprecision DC bearings are shown on pages 376-377.)

## INTERNAL CLEARANCES AND FITS

Drawn cup bearings are manufactured to a degree of precision that will satisfy the radial clearance requirements of most applications. The total radial clearance of an installed DC bearing results from the build-up of manufacturing tolerances of the housing bore, inner raceway o.d. and the bearing, as well as the minimum radial clearance required for the application.

For bearings of nominal inch dimensions, the recommended mounting dimensions will provide correct running clearance for most applications. Closer control of radial clearance would be governed by the user's capability of holding housing and shaft raceway dimensional tolerances tighter than the limits shown on the tabular pages.

For bearings of nominal metric dimensions, the recommended mounting dimensions shown on the tabular pages are consistent with ISO N7 housing bore and h6 inner raceway o.d. tolerances. When closer control of clearance is required, the user may select N6 housing bore and h5 inner raceway o.d. tolerances.

The drawing illustrates the manufacturing tolerances and the built-in clearances applying to medium size drawn cup bearings in rotating applications when using the recommended tabulated mounting dimensions.

Radial clearance in a mounted bearing may be more closely controlled by reducing the manufacturing tolerances of the housing bore and inner raceway diameter. Where extremely close control of radial clearance is required for bearings of nominal inch dimensions, extraprecision full complement bearings are available.

### Manufacturing Tolerances and Built-in Clearances

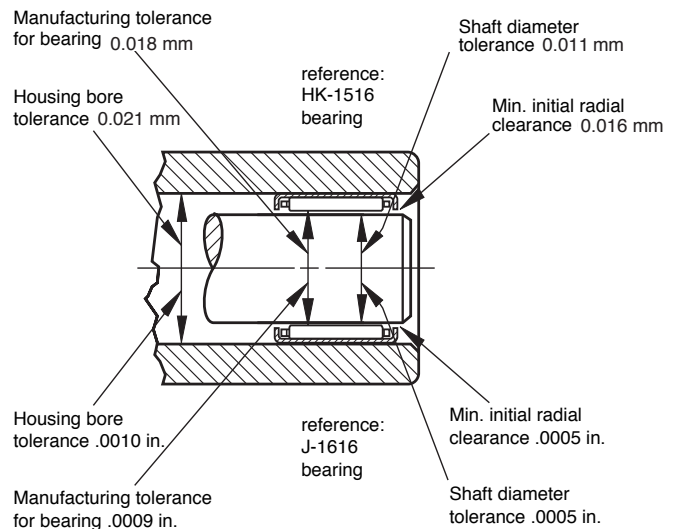

## OUTER RING ROTATION

For applications where the outer ring rotates with respect to the load, it is recommended that both the housing bore and the inner raceway diameter be reduced.

Bearings of nominal inch dimensions should have the housing bore and inner raceway diameter reduced by .0005" or .013 mm.

Bearings of nominal metric dimensions should follow ISO R7 and f6 tolerance practices.

## OSCILLATING MOTION

Applications involving oscillating motion often require reduced radial clearances. This reduction is accomplished by increasing the shaft raceway diameters as shown in Tables 2 and 3. The metric bearing user should note that addition of these values to the h6 tolerances given in tables of dimensions results in a standard j6 tolerance.

**Table 2**  
Nominal inch bearing oscillating shaft size

shaft size		add	
inch	mm	inch	mm
½ to ¾ incl	2.38 to 4.76 incl	0.0003	0.008
¾ to 1 ¼ incl	6.35 to 47.62 incl	0.0005	0.013
2 to 5 ½ incl	50.8 to 139.7 incl	0.0006	0.015

**Table 3**  
Nominal metric bearing oscillating shaft size

shaft size		add	
mm	inch	mm	inch
over 3 to 6	over .1181 to .2362	0.006	0.0002
over 6 to 10	over .2362 to .3937	0.007	0.0003
over 10 to 18	over .3937 to .7087	0.008	0.0003
over 18 to 30	over .7087 to 1.1811	0.009	0.0004
over 30 to 50	over 1.1811 to 1.9685	0.011	0.0004
over 50 to 80	over 1.9685 to 3.1496	0.012	0.0005

# DRAWN CUP NEEDLE ROLLER BEARINGS

## INSTALLATION PROCEDURES

A drawn cup bearing must be pressed into its housing. An installation tool similar to the one illustrated must be used in conjunction with a standard press.

It is advisable to utilize a positive stop on the press tool to locate the bearing properly in the housing. The assembly tool should have a leader or pilot, as shown, to aid in starting the bearing true in the housing.

The installation tool must be coaxial with the housing bore. The ball detent shown on the drawing is used to assist in aligning the rollers of a full complement bearing during installation and to hold the bearing on the installation tool.

Assemble the bearing with the stamped end (the end with identification markings) against the angled shoulder of the pressing tool.

**Never** hammer the bearing into its housing even in conjunction with the proper assembly mandrel.

**Never** press the bearing tightly against a shoulder in the housing. If it is necessary to use a shouldered housing, the depth of the housing bore must be sufficient to ensure the housing shoulder fillet, as well as the shoulder face, clears the bearing.

To remove a drawn cup bearing from a through-bored housing, use a tool similar to the installation tool illustrated, but without the stop. For suggested methods of removing bearings from blind and shouldered bores, consult the Torrington Engineering Sales Office personnel.

- A-  $\frac{1}{64}$ " (0.4 mm) less than housing bore
- B- .003" (0.08 mm) less than shaft diameter
- C- distance bearing will be inset into housing, minimum of .008" (0.2 mm)
- D- pilot length should be length of bearing less  $\frac{1}{32}$ " (0.8 mm)
- E- approximately  $\frac{1}{2}$  D

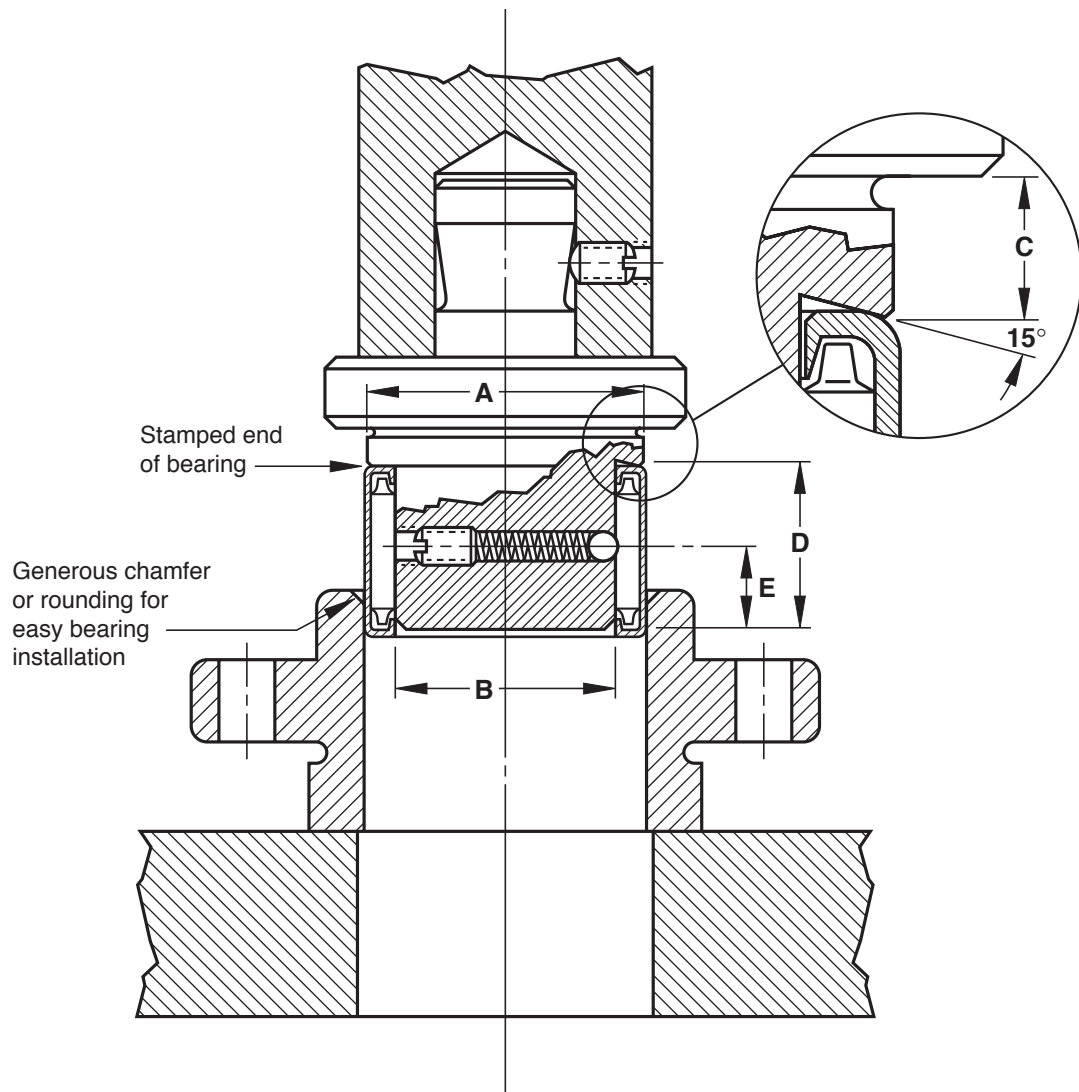

# DRAWN CUP NEEDLE ROLLER BEARINGS

## INNER RINGS

Where it becomes impractical to meet the shaft raceway design requirements (hardness, case depth, surface finish, etc.) outlined in the General Engineering section, standard inner rings for drawn cup bearings are available. These are tabulated on pages 380 to 383 of the drawn cup section.

Inner rings for drawn cup bearings are designed to be a loose transition fit on the shaft and should be clamped against a shoulder.

If a tight transition fit must be used to keep the inner ring from rotating relative to the shaft, the inner ring o.d., as mounted, must not exceed the raceway diameters required by the drawn cup bearing for the particular application. See the previous discussion on internal clearances and fits for further details on inner raceway diameter choice.

## LUBRICATION

Drawn cup bearings can be furnished with an oil hole (centered in the drawn cup) to facilitate relubrication. If desired, specify on order.

For general information regarding lubrication of drawn cup bearings refer to page E72.

## INSPECTION PROCEDURES

Although the bearing cup (outer ring) is accurately drawn from strip steel it may go out of round during heat treatment. When the bearing is pressed into a true round housing or ring gauge of correct size and wall thickness, it becomes round and is sized properly. **For this reason, it is incorrect to inspect an unmounted drawn cup bearing by measuring the o.d.** The correct method for inspecting the bearing size is to:

- (1) press the bearing into a ring gauge of proper size.
- (2) plug the bearing bore with the appropriate "go" and "no go" gauges.

Tables 4 and 5 provide the correct ring and plug gauge diameters for inspecting drawn cup needle roller bearings. When the letter **H** appears in the inch series bearings column headed "nominal bore diameter," the gauge sizes listed are for the larger cross section inch series bearings which include **H** in their bearing designation prefix.

### Example 1

Find the ring gauge and plug gauge dimensions for a BH-68 bearing.

Since the bearing designation prefix does not include the letter **SF** or **HK**, this bearing is of nominal inch dimensions. The nominal bore diameter for the bearing, as shown in the table of dimensions on page 364, is  $\frac{3}{8}$  inch. Since the letter **H** appears in the bearing designation, the following information will be found opposite **H**  $\frac{3}{8}$  in the **nominal bore diameter** column for the **inch series bearings** in Table 4:

	<u>inch</u>	<u>mm</u>
ring gauge	.6255	15.8877
diameter under needle rollers, min.	.3765	9.5631
diameter under needle rollers, max.	.3774	9.5860

The "go" plug gauge is the same size as the **minimum** diameter under the needle rollers and the "no go" plug gauge size is .0001 inch (.0025 mm) larger than the **maximum** diameter under the needle rollers. Therefore the correct ring and plug gauge dimensions are:

	<u>inch</u>	<u>mm</u>
ring gauge	.6255	15.8877
plug gauge, "go"	.3765	9.5631
plug gauge, "no go"	.3775	9.5885

These same gauge dimensions also apply to JH-68.

### Example 2

Find the ring gauge and plug gauge dimensions for a HK-1516 bearing.

The bearing designation prefix letters **HK** indicate that, the bearing is of nominal metric dimensions. The nominal bore diameter for this bearing, as shown in the table of dimensions on page 367, is 15 mm. Opposite "15", in the **nominal bore diameter** column for **metric series bearings** in Table 5, will be found the following information:

	<u>mm</u>	<u>inch</u>
ring gauge	20.976	.82583
diameter under needle rollers, min.	15.016	.59118
diameter under needle rollers, max.	15.034	.59189

The "go" plug gauge is the same size as the **minimum** diameter under the needle rollers and the "no go" plug gauge size is 0.0020 mm (.00008 inch) larger than the **maximum** diameter under the needle rollers. Therefore the correct ring and plug gauge dimensions are:

	<u>mm</u>	<u>inch</u>
ring gauge	20.976	.82583
plug gauge, "go"	15.016	.59118
plug gauge, "no go"	15.036	.59197

# DRAWN CUP NEEDLE ROLLER BEARINGS

**Table 4**

Inch series bearings

nominal bore diameter inch	dimensions-inch			dimensions-mm		
	ring gauge	diameter inside needle rollers		ring gauge	diameter inside needle rollers	
		min.	max.		min.	max.
1/8	0.2505	0.1258	0.1267	6.3627	3.1953	3.2182
5/32	0.2817	0.1571	0.1580	7.1552	3.9903	4.0132
3/16	0.3437	0.1883	0.1892	8.7300	4.7828	4.8057
1/4	0.4380	0.2515	0.2524	11.1252	6.3881	6.4110
5/16	0.5005	0.3140	0.3149	12.7127	7.9756	7.9985
<b>H</b> 5/16	0.5630	0.3140	0.3149	14.3002	7.9756	7.9985
3/8	0.5630	0.3765	0.3774	14.3002	9.5631	9.5860
<b>H</b> 3/8	0.6255	0.3765	0.3774	15.8877	9.5631	9.5860
7/16	0.6255	0.4390	0.4399	15.8877	11.1506	11.1735
<b>H</b> 7/16	0.6880	0.4390	0.4399	17.4752	11.1506	11.1735
1/2	0.6880	0.5015	0.5024	17.4752	12.7381	12.7610
<b>H</b> 1/2	0.7505	0.5015	0.5024	19.0627	12.7381	12.7610
5/16	0.7505	0.5640	0.5649	19.0627	14.3256	14.3485
<b>H</b> 5/16	0.8130	0.5640	0.5649	20.6502	14.3256	14.3485
3/4	0.8130	0.6265	0.6274	20.6502	15.9131	15.9360
<b>H</b> 3/4	0.8755	0.6265	0.6274	22.2377	15.9131	15.9360
11/16	0.8755	0.6890	0.6899	22.2377	17.5006	17.5235
<b>H</b> 11/16	0.9380	0.6890	0.6899	23.8252	17.5006	17.5235
3/4	0.9995	0.7505	0.7514	25.3873	19.0627	19.0856
<b>H</b> 3/4	1.0620	0.7505	0.7514	26.9748	19.0627	19.0856
13/16	1.0620	0.8130	0.8139	26.9748	20.6502	20.6731
<b>H</b> 13/16	1.1245	0.8130	0.8139	28.5623	20.6502	20.6731
7/8	1.1245	0.8755	0.8764	28.5623	22.2377	22.2606
<b>H</b> 7/8	1.1870	0.8755	0.8764	30.1498	22.2377	22.2606
15/16	1.1870	0.9380	0.9389	30.1498	23.8252	23.8481
1	1.2495	1.0005	1.0014	31.7373	25.4127	25.4356
<b>H</b> 1	1.3120	1.0005	1.0014	33.3248	25.4127	25.4356
1 1/16	1.3120	1.0630	1.0639	33.3248	27.0002	27.0231
1 1/8	1.3745	1.1255	1.1264	34.9123	28.5877	28.6106
<b>H</b> 1 1/8	1.4995	1.1255	1.1264	38.0873	28.5877	28.6106
1 3/16	1.4995	1.1880	1.1889	38.0873	30.1752	30.1981
1 1/4	1.4995	1.2505	1.2514	38.0873	31.7627	31.7856
<b>H</b> 1 1/4	1.6245	1.2505	1.2514	41.2623	31.7627	31.7856
1 5/16	1.6245	1.3130	1.3140	41.2623	33.3502	33.3756
1 3/8	1.6245	1.3755	1.3765	41.2623	34.9377	34.9631
<b>H</b> 1 3/8	1.7495	1.3755	1.3765	44.4373	34.9377	34.9631
1 1/2	1.8745	1.5005	1.5016	47.6123	38.1127	38.1406
1 5/8	1.9995	1.6255	1.6266	50.7873	41.2877	41.3156
1 3/4	2.1245	1.7505	1.7517	53.9623	44.4627	44.4932
1 7/8	2.2495	1.8755	1.8767	57.1373	47.6377	47.6682
2	2.3745	2.0006	2.0018	60.3123	50.8152	50.8457
<b>H</b> 2 1/16	2.5307	2.0635	2.0649	64.2798	52.4129	52.4485
2 1/8	2.4995	2.1256	2.1270	63.4873	53.9902	54.0258
2 1/4	2.6245	2.2506	2.2520	66.6623	57.1652	57.2008
<b>NB</b> 2 1/2	2.8795	2.5006	2.5020	73.1393	63.5152	63.5508
2 3/8	2.9995	2.6260	2.6274	76.1873	66.7004	66.7360
2 1/2	3.1245	2.7510	2.7524	79.3623	69.8754	69.9110
<b>NBH</b> 3	3.5045	3.0006	3.0020	89.0143	76.2152	76.2508
3 1/2	3.9995	3.5010	3.5024	101.5873	88.9254	88.9610
5 1/2	5.9990	5.5010	5.5029	152.3746	139.7254	139.7737

**Table 5**

Metric series bearings

nominal bore diameter mm	dimensions-mm			dimensions-inch		
	ring gauge *	diameter inside needle rollers		ring gauge *	diameter inside needle rollers	
		min.	max.		min.	max.
4	7.984	4.010	4.028	0.31433	0.15787	0.15858
5	8.984	5.010	5.028	0.35370	0.19724	0.19795
6	9.984	6.010	6.028	0.39307	0.23661	0.23732
7	10.980	7.013	7.031	0.43228	0.27610	0.27681
8	11.980	8.013	8.031	0.47165	0.31547	0.31618
9	12.980	9.013	9.031	0.51102	0.35484	0.35555
10	13.980	10.013	10.031	0.55039	0.39421	0.39492
12	15.980	12.016	12.034	0.62913	0.47307	0.47378
12	17.980	12.016	12.034	0.70787	0.47307	0.47378
13	18.976	13.016	13.034	0.74709	0.51244	0.51315
14	19.976	14.016	14.034	0.78646	0.55181	0.55252
15	20.976	15.016	15.034	0.82583	0.59118	0.59189
16	21.976	16.016	16.034	0.86520	0.63055	0.63126
17	22.976	17.016	17.034	0.90457	0.66992	0.67063
18	23.976	18.016	18.034	0.94394	0.70929	0.71000
20	25.976	20.020	20.041	1.02268	0.78819	0.78901
22	27.976	22.020	22.041	1.10142	0.86693	0.86776
25	31.972	25.020	25.041	1.25874	0.98504	0.98586
28	34.972	28.020	28.041	1.37685	1.10315	1.10398
30	36.972	30.020	30.041	1.45559	1.18189	1.18272
35	41.972	35.025	35.050	1.65244	1.37894	1.37992
40	46.972	40.025	40.050	1.84929	1.57579	1.57677
45	51.967	45.025	45.050	2.04594	1.77264	1.77362
50	57.967	50.025	50.050	2.28217	1.96949	1.97047
55	62.967	55.030	55.060	2.47902	2.16654	2.16772
64	71.967	64.030	64.060	2.83335	2.52087	2.52205

Bearing bore should be checked with "go" and "no go" plug gauges. The "go" gauge size is the minimum diameter inside the needle rollers. The "no go" gauge size is larger than the maximum diameter inside the needle rollers by the following amounts:

- Inch Series – 0.0001 inch
- 0.0025 millimeters
- Metric Series – 0.0020 millimeters
- 0.00008 inch

\* The ring gauge sizes for metric series bearings are in accordance with ISO N6 lower limit.

Inch - metric conversions given are for the convenience of the user. The controlling dimensions are in inches for nominal inch bearings and in millimeters for nominal metric bearings.



# DRAWN CUP NEEDLE ROLLER BEARINGS

## Caged Bearings

Check for availability.

Inch - metric conversions given are for the convenience of the user. The controlling dimensions are in inches for nominal inch bearings and in millimeters for nominal metric bearings.

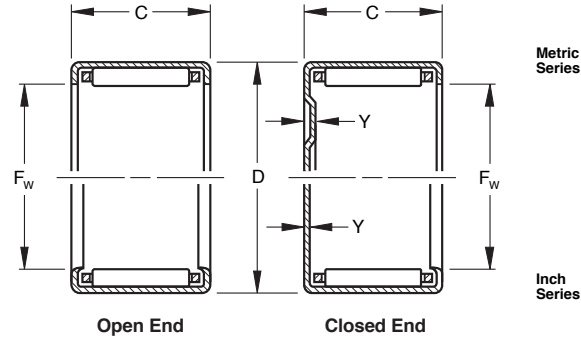

BEARING MOUNTING				CAGE RETAINED ROLLERS						Limiting Speed Caged Bearings	Y End Thickness	
Metric Mounting				Bearing Designation	Load Ratings			rpm	Y End Thickness			
S Shaft Raceway Diameter	H Housing Bore				Basic Dynamic Cr	Basic Static Co	Working Load		Y End Thickness			
millimeters	millimeters			open end	closed end	Ⓓ	ISO 281	ISO 76	(max.)	inch	mm	
max.	min.	min.	max.			lbf	lbf	lbf	lbf	rpm	inch	mm
3,000	2,992	6,481	6,496	HK-0306	—	239	327	257	86	13 000	—	—
3,175	3,167	6,350	6,363	JP-23-F	—	109	149	105	69	75 000	—	—
3,175	3,167	6,350	6,363	—	—	—	—	—	—	—	—	—
3,970	3,962	7,142	7,155	JP-2 1/2 3-F	—	111	152	110	69	75 000	—	—
3,970	3,962	7,142	7,155	—	—	—	—	—	—	—	—	—
3,970	3,962	7,142	7,155	—	—	—	—	—	—	—	—	—
4,000	3,992	7,981	7,996	HK-0408	—	280	384	310	103	75 000	—	—
4,762	4,754	8,717	8,730	—	—	—	—	—	—	—	—	—
4,762	4,754	8,717	8,730	J-36	MJ-361	257	352	336	202	75 000	0.04	1.0
5,000	4,992	8,981	8,996	HK-0509	—	376	515	466	155	74 000	—	—
6,000	5,992	9,981	9,996	HK-0608	—	350	479	438	146	60 000	—	—
6,000	5,992	9,981	9,996	HK-0609	BK-0609	496	679	641	214	60 000	0.06	1.6
—	—	—	—	—	—	—	—	—	—	—	—	—
6,350	6,337	11,100	11,125	J-45	MJ-451	290	397	331	203	57 000	0.04	1.0
6,350	6,337	11,100	11,125	J-47	MJ-471	473	648	617	379	57 000	0.04	1.0
7,000	6,991	10,977	10,995	HK-0709	—	482	660	686	229	50 000	—	—
7,938	7,925	12,687	12,712	J-55	—	315	431	383	226	44 000	—	—
7,938	7,925	12,687	12,712	—	—	—	—	—	—	—	—	—
7,938	7,925	12,687	12,712	J-57	MJ-571	560	767	805	474	44 000	0.04	1.0
7,938	7,925	12,687	12,712	—	—	—	—	—	—	—	—	—
7,938	7,925	14,275	14,300	JH-57	MJH-571	696	954	849	543	47 000	0.04	1.0
7,938	7,925	14,275	14,300	—	—	—	—	—	—	—	—	—
8,000	7,991	11,977	11,995	HK-0808	BK-0808	433	593	615	205	43 000	0.06	1.6
8,000	7,991	11,977	11,995	HK-0810	BK-0810	590	808	915	305	43 000	0.06	1.6
9,000	8,991	12,977	12,995	HK-0910	—	683	936	1 140	380	38 000	—	—
9,000	8,991	12,977	12,995	HK-0912	BK-0912	843	1 164	1 500	500	38 000	0.06	1.6
9,525	9,512	14,275	14,300	J-65	MJ-651	358	491	474	271	36 000	0.04	1.0
—	—	—	—	—	—	—	—	—	—	—	—	—
9,525	9,512	14,275	14,300	—	—	—	—	—	—	—	—	—
9,525	9,512	14,275	14,300	J-68	—	755	1 030	1 240	707	36 000	—	—
9,525	9,512	14,275	14,300	—	—	—	—	—	—	—	—	—
9,525	9,512	14,275	14,300	—	—	—	—	—	—	—	—	—
9,525	9,512	15,862	15,887	JH-68	—	987	1 350	1 370	843	38 000	—	—
10,000	9,991	13,977	13,995	HK-1010	—	713	982	1 240	413	34 000	—	—
10,000	9,991	13,977	13,995	HK-1012	—	881	1 210	1 630	543	34 000	—	—
10,000	9,991	13,977	13,995	HK-1015	—	1 120	1 530	2 210	737	34 000	—	—

Mounting dimensions are based on the inner ring rotating and the outer ring being stationary relative to the load. The housing should be of high strength material. See pages E77-78 for discussion of shaft and housing design.

Drawn cup bearings of nominal inch and metric dimensions with one closed end, which are not tabulated, may be made available upon request.

Caged drawn cup bearings of nominal inch and metric dimensions, with an engineered polymer cage, may be made available upon request.

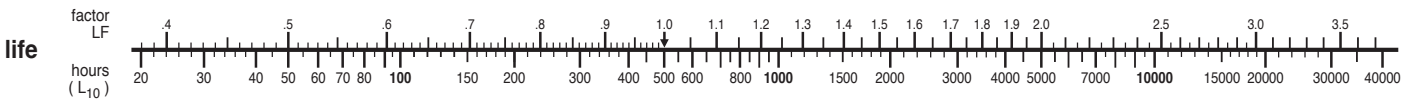



# DRAWN CUP NEEDLE ROLLER BEARINGS

## Full Complement Bearings

Check for availability.

Inch-metric conversions given are for the convenience of the user. The controlling dimensions are in inches for nominal inch bearings and in millimeters for nominal metric bearings.

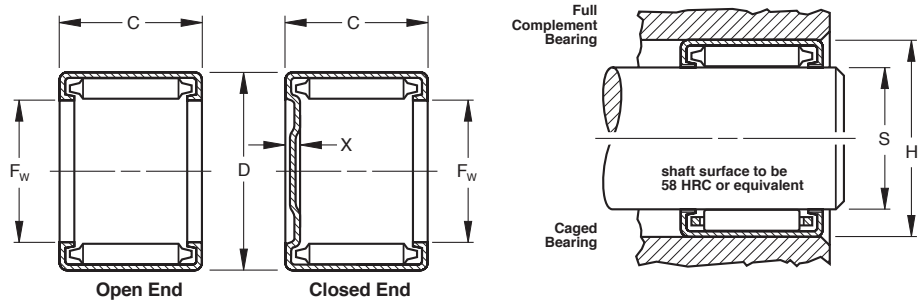

BEARING DIMENSIONS						MECHANICALLY RETAINED ROLLERS						BEARING MOUNTING						
F <sub>w</sub> Bore		D Outside Diameter		C Width		Bearing Designation		Load Ratings				Limiting Speed Full Complement Bearings	X End Thickness		Inch Mounting			
(nom.)		(nom.)		+0.000	+0.00	open end	closed end	Basic Dynamic C <sub>r</sub>	Basic Static C <sub>0</sub>	Working Load	(max.)		(max.)	S Shaft Raceway Diameter		H Housing Bore		
inch	mm	inch	mm	-0.010	-0.25			Ⓣ	ISO 281	ISO 76		(max.)		rpm	inch	mm	max.	min.
7/16	11,11	5/16	15,88	0.375	9,52	B-76	—	906	1 390	1 930	1 080	6 300	—	—	0.4375	0.4370	0.6245	0.6255
7/16	11,11	5/16	15,88	0.438	11,13	B-77	—	1 100	1 700	2 480	1 390	6 300	—	—	0.4375	0.4370	0.6245	0.6255
7/16	11,11	5/16	15,88	0.500	12,70	B-78	M-781	1 290	1 980	3 030	1 690	6 300	0.08	2.0	0.4375	0.4370	0.6245	0.6255
7/16	11,11	5/16	15,88	0.625	15,88	B-710	—	1 640	2 520	4 130	2 310	6 300	—	—	0.4375	0.4370	0.6245	0.6255
7/16	11,11	11/16	17,46	0.500	12,70	BH-78	—	1 470	2 260	2 780	1 660	8 300	—	—	0.4375	0.4370	0.6870	0.6880
0.47	12	0.63	16	0.394	10	—	—	—	—	—	—	—	—	—	0.4724	0.4720	0.6290	0.6297
0.47	12	0.71	18	0.472	12	—	—	—	—	—	—	—	—	—	0.4724	0.4720	0.7078	0.7085
1/2	12,70	11/16	17,46	0.312	7,92	B-85	—	754	1 160	1 580	870	5 500	—	—	0.5000	0.4995	0.6870	0.6880
1/2	12,70	11/16	17,46	0.375	9,52	B-86	M-861	976	1 500	2 200	1 210	5 500	0.08	2.0	0.5000	0.4995	0.6870	0.6880
1/2	12,70	11/16	17,46	0.438	11,13	B-87	M-871	1 190	1 830	2 840	1 560	5 500	0.08	2.0	0.5000	0.4995	0.6870	0.6880
1/2	12,70	11/16	17,46	0.500	12,70	B-88	M-881	1 390	2 130	3 460	1 910	5 500	0.08	2.0	0.5000	0.4995	0.6870	0.6880
1/2	12,70	11/16	17,46	0.625	15,88	B-810	M-8101	1 770	2 720	4 720	2 600	5 500	0.08	2.0	0.5000	0.4995	0.6870	0.6880
1/2	12,70	11/16	17,46	0.750	19,05	B-812	M-8121	2 120	3 260	5 980	3 290	5 500	0.08	2.0	0.5000	0.4995	0.6870	0.6880
1/2	12,70	3/4	19,05	0.438	11,13	BH-87	—	1 340	2 060	2 550	1 490	7 500	—	—	0.5000	0.4995	0.7495	0.7505
1/2	12,70	3/4	19,05	0.500	12,70	BH-88	—	1 590	2 450	3 180	1 850	7 500	—	—	0.5000	0.4995	0.7495	0.7505
1/2	12,70	3/4	19,05	0.625	15,88	BH-810	—	2 060	3 180	4 440	2 590	7 500	—	—	0.5000	0.4995	0.7495	0.7505
1/2	12,70	3/4	19,05	0.750	19,05	BH-812	—	2 510	3 850	5 690	3 290	7 500	—	—	0.5000	0.4995	0.7495	0.7505
0.51	13	0.75	19	0.472	12	—	—	—	—	—	—	—	—	—	0.5118	0.5114	0.7469	0.7477
0.55	14	0.79	20	0.472	12	—	—	—	—	—	—	—	—	—	0.5512	0.5508	0.7863	0.7871
5/16	14,29	3/4	19,05	0.312	7,92	B-95	M-951	804	1 240	1 780	966	5 000	0.08	2.0	0.5625	0.5620	0.7495	0.7505
5/16	14,29	3/4	19,05	0.375	9,52	B-96	—	1 040	1 600	2 480	1 350	5 000	—	—	0.5625	0.5620	0.7495	0.7505
5/16	14,29	3/4	19,05	0.438	11,13	B-97	—	1 270	1 950	3 190	1 740	5 000	—	—	0.5625	0.5620	0.7495	0.7505
5/16	14,29	3/4	19,05	0.500	12,70	B-98	—	1 480	2 280	3 900	2 120	5 000	—	—	0.5625	0.5620	0.7495	0.7505
5/16	14,29	3/4	19,05	0.625	15,88	B-910	—	1 880	2 900	5 310	2 890	5 000	—	—	0.5625	0.5620	0.7495	0.7505
5/16	14,29	3/4	19,05	0.750	19,05	B-912	M-9121	2 260	3 480	6 730	3 660	5 000	0.08	2.0	0.5625	0.5620	0.7495	0.7505
5/16	14,29	11/16	20,64	0.500	12,70	BH-98	—	1 710	2 630	3 580	2 050	6 800	—	—	0.5625	0.5620	0.8120	0.8130
5/16	14,29	11/16	20,64	0.625	15,88	BH-910	—	2 210	3 400	5 000	2 860	6 800	—	—	0.5625	0.5620	0.8120	0.8130
5/16	14,29	11/16	20,64	0.750	19,05	BH-912	—	2 690	4 130	6 410	3 670	6 800	—	—	0.5625	0.5620	0.8120	0.8130
0.59	15	0.83	21	0.472	12	—	—	—	—	—	—	—	—	—	0.5906	0.5902	0.8257	0.8265
0.59	15	0.83	21	0.630	16	—	—	—	—	—	—	—	—	—	0.5906	0.5902	0.8257	0.8265
5/8	15,88	11/16	20,64	0.312	7,92	B-105	—	851	1 310	1 980	1 060	4 500	—	—	0.6250	0.6245	0.8120	0.8130
5/8	15,88	11/16	20,64	0.438	11,13	B-107	M-1071	1 340	2 070	3 550	1 910	4 500	0.08	2.0	0.6250	0.6245	0.8120	0.8130
5/8	15,88	11/16	20,64	0.500	12,70	B-108	M-1081	1 570	2 410	4 330	2 330	4 500	0.08	2.0	0.6250	0.6245	0.8120	0.8130
5/8	15,88	11/16	20,64	0.625	15,88	B-1010	—	1 990	3 070	5 900	3 180	4 500	—	—	0.6250	0.6245	0.8120	0.8130
5/8	15,88	11/16	20,64	0.750	19,05	B-1012	M-10121	2 400	3 690	7 480	4 020	4 500	0.08	2.0	0.6250	0.6245	0.8120	0.8130

Ⓣ Symbol denotes Basic Dynamic Load Rating to be used in load-life calculations taking into consideration the application guidelines and limitations given in this catalog. Applications involving loads approaching this rating or the tabulated working load, whichever is the smaller, should be referred to the Torrington Engineering Sales Office before a final selection is made.

Load ratings are based on a minimum raceway hardness of 58 HRC or equivalent. Load ratings are given in pounds-force: 1 lbf = 0.454kgf = 4.448N. Required Basic Dynamic Load Rating (C<sub>r</sub>) = Applied Load • SF • LF • HF (see page E75).

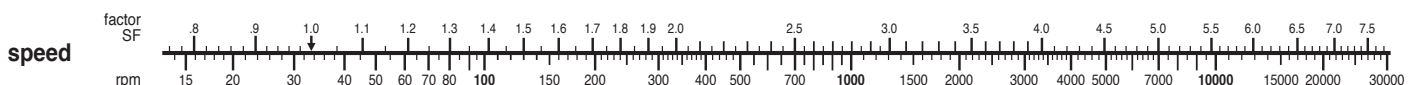

# DRAWN CUP NEEDLE ROLLER BEARINGS

## Caged Bearings

Check for availability.

Inch-metric conversions given are for the convenience of the user. The controlling dimensions are in inches for nominal inch bearings and in millimeters for nominal metric bearings.

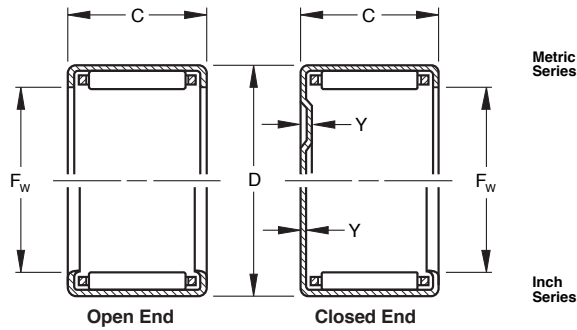

BEARING MOUNTING				CAGE RETAINED ROLLERS								
Metric Mounting				Bearing Designation	Load Ratings				Limiting Speed Caged Bearings	Y End Thickness		
S Shaft Raceway Diameter		H Housing Bore			open end	closed end	Basic Dynamic	Basic Static		Working Load		
millimeters	millimeters	millimeters	millimeters				$C_r$	$C_o$		(max.)	rpm	inch
max.	min.	min.	max.			Ⓓ	ISO 281	ISO 76			(max.)	
lbf	lbf	lbf	lbf									
11,112	11,099	15,862	15,887	—	—	—	—	—	—	—	—	
11,112	11,099	15,862	15,887	—	—	—	—	—	—	—	—	
11,112	11,099	15,862	15,887	J-78	MJ-781	882	1 210	1 580	883	30 000	0.04 1.0	
11,112	11,099	15,862	15,887	—	—	—	—	—	—	—	—	
11,112	11,099	17,450	17,475	JH-78	—	1 060	1 450	1 510	928	38 000	— —	
12,000	11,989	15,977	15,995	HK-1210	BK-1210	740	1 110	1 370	460	28 000	0.06 1.6	
12,000	11,989	17,977	17,995	HK-1212	BK-1212	986	1 350	1 640	547	28 000	0.11 2.7	
12,700	12,687	17,450	17,475	J-85	MJ-851	454	621	697	384	26 000	0.04 1.0	
12,700	12,687	17,450	17,475	J-86	MJ-861	661	906	1 130	598	26 000	0.04 1.0	
12,700	12,687	17,450	17,475	—	—	—	—	—	—	—	—	
12,700	12,687	17,450	17,475	J-88	MJ-881	914	1 250	1 710	942	26 000	0.04 1.0	
12,700	12,687	17,450	17,475	—	—	—	—	—	—	—	—	
12,700	12,687	17,450	17,475	J-812	—	1 500	2 060	3 240	1 790	26 000	— —	
12,700	12,687	19,037	19,062	JH-87	—	958	1 310	1 400	816	27 000	— —	
12,700	12,687	19,037	19,062	JH-88	MJH-881	1 160	1 590	1 800	1 050	27 000	0.04 1.0	
12,700	12,687	19,037	19,062	—	—	—	—	—	—	—	—	
12,700	12,687	19,037	19,062	JH-812	—	1 840	2 530	3 250	1 900	27 000	— —	
13,000	12,989	18,972	18,993	HK-1312	BK-1312	1 030	1 410	1 770	590	26 000	0.11 2.7	
14,000	13,989	19,972	19,993	HK-1412	—	1 080	1 470	1 910	640	24 000	— —	
14,288	14,275	19,037	19,062	—	—	—	—	—	—	—	—	
14,288	14,275	19,037	19,062	—	—	—	—	—	—	—	—	
14,288	14,275	19,037	19,062	J-97	—	761	1 040	1 400	758	23 000	— —	
14,288	14,275	19,037	19,062	J-98	—	901	1 230	1 730	942	23 000	— —	
14,288	14,275	19,037	19,062	J-910	—	1 190	1 630	2 490	1 350	23 000	— —	
14,288	14,275	19,037	19,062	—	—	—	—	—	—	—	—	
14,288	14,275	20,625	20,650	—	—	—	—	—	—	—	—	
14,288	14,275	20,625	20,650	—	—	—	—	—	—	—	—	
14,288	14,275	20,625	20,650	—	—	—	—	—	—	—	—	
15,000	14,989	20,972	20,993	HK-1512	BK-1512	1 120	1 530	2 050	680	22 000	0.11 2.7	
15,000	14,989	20,972	20,993	HK-1516	BK-1516	1 590	2 180	3 230	1 080	22 000	0.11 2.7	
15,875	15,862	20,625	20,650	—	—	—	—	—	—	—	—	
15,875	15,862	20,625	20,650	—	—	—	—	—	—	—	—	
15,875	15,862	20,625	20,650	J-108	—	970	1 330	1 970	1 060	21 000	— —	
15,875	15,862	20,625	20,650	J-1010	MJ-10101	1 280	1 760	2 830	1 520	21 000	0.04 1.0	
15,875	15,862	20,625	20,650	J-1012	MJ-10121	1 850	2 540	4 570	2 460	21 000	0.04 1.0	

Mounting dimensions are based on the inner ring rotating and the outer ring being stationary relative to the load. The housing should be of high strength material. See pages E77-78 for discussion of shaft and housing design.

Drawn cup bearings of nominal inch and metric dimensions with one closed end, which are not tabulated, may be made available upon request.

Caged drawn cup bearings of nominal inch and metric dimensions, with an engineered polymer cage, may be made available upon request.

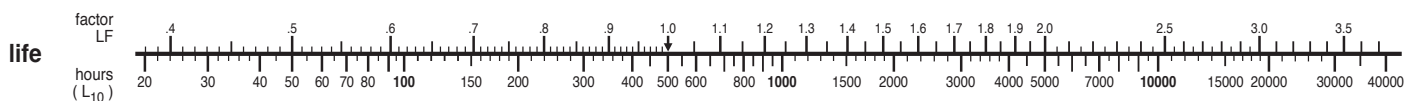

# DRAWN CUP NEEDLE ROLLER BEARINGS

## Full Complement Bearings

Check for availability.

Inch-metric conversions given are for the convenience of the user. The controlling dimensions are in inches for nominal inch bearings and in millimeters for nominal metric bearings.

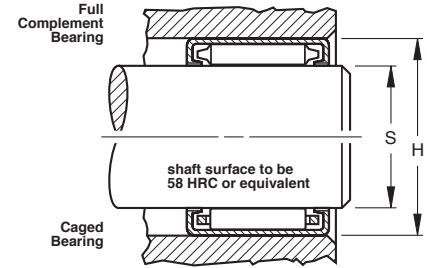
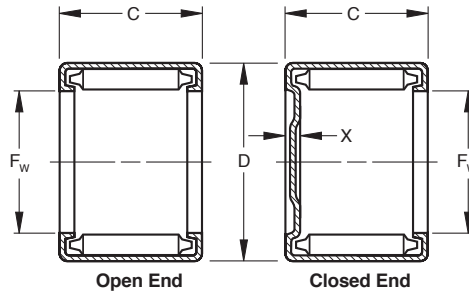

BEARING DIMENSIONS						MECHANICALLY RETAINED ROLLERS						BEARING MOUNTING						
F <sub>w</sub> Bore		D Outside Diameter		C Width		Bearing Designation		Load Ratings			Limiting Speed Full Complement Bearings	X End Thickness		Inch Mounting				
(nom.)	(nom.)	(nom.)	(nom.)	+0.000 -0.010	+0.00 -0.25	open end	closed end	Basic Dynamic C <sub>r</sub>	Basic Static C <sub>0</sub>	Working Load		(max.)	(max.)	S Shaft Raceway Diameter		H Housing Bore		
inch	mm	inch	mm	inch	mm			Ⓓ	ISO 281	ISO 76	(max.)	rpm	inch	mm	max.	min.	min.	max.
5/16	15.88	5/16	22.22	0.500	12.70	BH-108	MH-1081	1 810	2 790	3 980	2 240	6 200	0.09	2.3	0.6250	0.6245	0.8745	0.8755
5/16	15.88	5/16	22.22	0.625	15.88	BH-1010	—	2 350	3 620	5 530	3 130	6 200	—	—	0.6250	0.6245	0.8745	0.8755
5/16	15.88	5/16	22.22	0.750	19.05	BH-1012	—	2 850	4 390	7 130	4 010	6 200	—	—	0.6250	0.6245	0.8745	0.8755
5/16	15.88	5/16	22.22	1.000	25.40	BH-1016	—	3 790	5 830	10 300	5 780	6 200	—	—	0.6250	0.6245	0.8745	0.8755
0.63	16	0.87	22	0.472	12	—	—	—	—	—	—	—	—	—	0.6299	0.6295	0.8650	0.8658
0.63	16	0.87	22	0.630	16	—	—	—	—	—	—	—	—	—	0.6299	0.6295	0.8650	0.8658
0.67	17	0.91	23	0.472	12	—	—	—	—	—	—	—	—	—	0.6693	0.6689	0.9044	0.9052
11/16	17.46	5/16	22.22	0.375	9.52	B-116	—	1 160	1 790	3 030	1 620	4 200	—	—	0.6875	0.6870	0.8745	0.8755
11/16	17.46	5/16	22.22	0.500	12.70	B-118	—	1 650	2 540	4 770	2 540	4 200	—	—	0.6875	0.6870	0.8745	0.8755
11/16	17.46	5/16	22.22	0.625	15.88	B-1110	M-11101	2 100	3 230	6 500	3 460	4 200	0.08	2.0	0.6875	0.6870	0.8745	0.8755
11/16	17.46	5/16	22.22	0.750	19.05	B-1112	M-11121	2 520	3 880	8 230	4 390	4 200	0.08	2.0	0.6875	0.6870	0.8745	0.8755
11/16	17.46	19/16	23.81	0.438	11.13	BH-117	—	1 610	2 480	3 510	1 950	5 700	—	—	0.6875	0.6870	0.9370	0.9380
11/16	17.46	19/16	23.81	0.625	15.88	BH-1110	MH-11101	2 480	3 820	6 110	3 400	5 700	0.09	2.3	0.6875	0.6870	0.9370	0.9380
11/16	17.46	19/16	23.81	0.750	19.05	BH-1112	—	3 010	4 640	7 840	4 360	5 700	—	—	0.6875	0.6870	0.9370	0.9380
0.71	18	0.94	24	0.472	12	—	—	—	—	—	—	—	—	—	0.7087	0.7083	0.9438	0.9446
0.71	18	0.94	24	0.630	16	—	—	—	—	—	—	—	—	—	0.7087	0.7083	0.9438	0.9446
3/4	19.05	1	25.40	0.375	9.52	B-126	—	1 360	2 100	2 900	1 600	5 500	—	—	0.7500	0.7495	0.9995	1.0005
3/4	19.05	1	25.40	0.500	12.70	B-128	M-1281	2 010	3 100	4 790	2 630	5 500	0.09	2.3	0.7500	0.7495	0.9995	1.0005
3/4	19.05	1	25.40	0.625	15.88	B-1210	M-12101	2 610	4 010	6 670	3 670	5 500	0.09	2.3	0.7500	0.7495	0.9995	1.0005
3/4	19.05	1	25.40	0.750	19.05	B-1212	M-12121	3 160	4 870	8 560	4 710	5 500	0.09	2.3	0.7500	0.7495	0.9995	1.0005
0.79	20	1.02	26	0.472	12	—	—	—	—	—	—	—	—	—	0.7874	0.7869	1.0225	1.0233
0.79	20	1.02	26	0.630	16	—	—	—	—	—	—	—	—	—	0.7874	0.7869	1.0225	1.0233
0.79	20	1.02	26	0.787	20	—	—	—	—	—	—	—	—	—	0.7874	0.7869	1.0225	1.0233
19/16	20.64	1 1/16	26.99	0.375	9.52	B-136	—	1 420	2 190	3 140	1 710	5 200	—	—	0.8125	0.8120	1.0620	1.0630
19/16	20.64	1 1/16	26.99	0.500	12.70	B-138	M-1381	2 100	3 240	5 190	2 830	5 200	0.09	2.3	0.8125	0.8120	1.0620	1.0630
19/16	20.64	1 1/16	26.99	0.875	22.22	B-1314	—	3 860	5 940	11 300	6 180	5 200	—	—	0.8125	0.8120	1.0620	1.0630
19/16	20.64	1 1/16	26.99	1.000	25.40	B-1316	M-13161	4 390	6 760	13 400	7 290	5 200	0.09	2.3	0.8125	0.8120	1.0620	1.0630
19/16	20.64	1 1/8	28.58	0.625	15.88	BH-1310	—	2 810	4 320	6 510	3 640	6 200	—	—	0.8125	0.8120	1.1245	1.1255
19/16	20.64	1 1/8	28.58	0.750	19.05	BH-1312	—	3 470	5 340	8 550	4 790	6 200	—	—	0.8125	0.8120	1.1245	1.1255
0.87	22	1.1	28	0.472	12	—	—	—	—	—	—	—	—	—	0.8661	0.8656	1.1013	1.1021
0.87	22	1.1	28	0.630	16	—	—	—	—	—	—	—	—	—	0.8661	0.8656	1.1013	1.1021
0.87	22	1.1	28	0.787	20	—	—	—	—	—	—	—	—	—	0.8661	0.8656	1.1013	1.1021

Ⓓ Symbol denotes Basic Dynamic Load Rating to be used in load-life calculations taking into consideration the application guidelines and limitations given in this catalog. Applications involving loads approaching this rating or the tabulated working load, whichever is the smaller, should be referred to the Torrington Engineering Sales Office before a final selection is made.

Load Ratings are based on a minimum raceway hardness of 58 HRC or equivalent. Load ratings are given in pounds-force: 1 lbf = 0.454kgf = 4.448N Required Basic Dynamic Load Rating (Cr) = Applied Load • SF • LF • HF (see page E75).

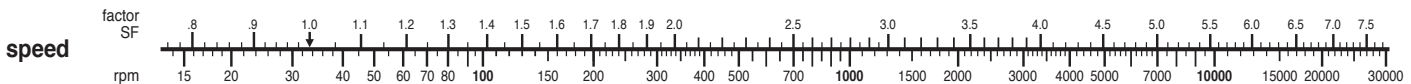

# DRAWN CUP NEEDLE ROLLER BEARINGS

## Caged Bearings

Check for availability.

Inch-metric conversions given are for the convenience of the user. The controlling dimensions are in inches for nominal inch bearings and in millimeters for nominal metric bearings.

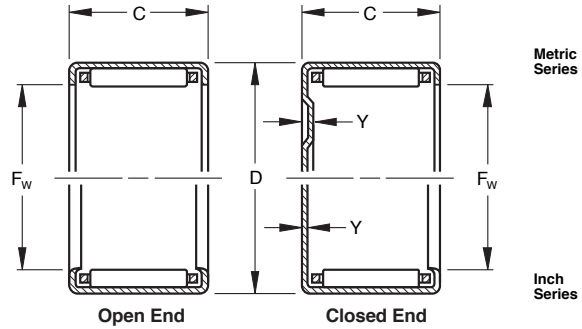

BEARING MOUNTING				CAGE RETAINED ROLLERS								
Metric Mounting				Bearing Designation	Load Ratings				Limiting Speed Caged Bearings	Y End Thickness		
S Shaft Raceway Diameter		H Housing Bore			Basic Dynamic $C_r$	Basic Static $C_o$	Working Load	Limiting Speed Caged Bearings		Y End Thickness		
millimeters		millimeters								open end	closed end	(max.)
max.	min.	min.	max.					rpm	inch	mm		
15,875	15,862	22,212	22,237	—	—	—	—	—	—	—		
15,875	15,862	22,212	22,237	JH-1010	—	1 730	2 370	3 180	1 790	21 000	—	—
15,875	15,862	22,212	22,237	—	—	—	—	—	—	—	—	—
15,875	15,862	22,212	22,237	JH-1016	—	2 960	4 050	6 330	3 560	21 000	—	—
16,000	15,989	21,972	21,993	HK-1612	—	1 160	1 590	2 180	730	21 000	—	—
16,000	15,989	21,972	21,993	HK-1616	—	1 650	2 260	3 450	1 150	21 000	—	—
17,000	16,989	22,972	22,993	HK-1712	—	1 210	1 660	2 350	780	20 000	—	—
17,462	17,449	22,212	22,237	—	—	—	—	—	—	—	—	—
17,462	17,449	22,212	22,237	—	—	—	—	—	—	—	—	—
17,462	17,449	22,212	22,237	—	—	—	—	—	—	—	—	—
17,462	17,449	22,212	22,237	J-1112	—	1 830	2 500	4 610	2 460	19 000	—	—
17,462	17,449	23,800	23,825	—	—	—	—	—	—	—	—	—
17,462	17,449	23,800	23,825	JH-1110	—	1 800	2 470	3 430	1 910	19 000	—	—
17,462	17,449	23,800	23,825	JH-1112	—	2 410	3 300	5 000	2 780	19 000	—	—
18,000	17,989	23,972	23,993	HK-1812	—	1 250	1 720	2 500	830	18 000	—	—
18,000	17,989	23,972	23,993	HK-1816	—	1 910	2 620	4 290	1 430	18 000	—	—
19,050	19,037	25,387	25,412	J-126	—	975	1 340	1 600	879	18 000	—	—
19,050	19,037	25,387	25,412	J-128	—	1 490	2 040	2 760	1 520	18 000	—	—
19,050	19,037	25,387	25,412	J-1210	—	1 870	2 560	3 690	2 030	18 000	0.04	1.0
19,050	19,037	25,387	25,412	J-1212	MJ-12101 MJ-12121	2 320	3 180	4 880	2 680	18 000	0.04	1.0
20,000	19,987	25,972	25,993	HK-2012	—	1 340	1 830	2 810	940	16 000	—	—
20,000	19,987	25,972	25,993	HK-2016	—	1 850	2 530	4 240	1 410	16 000	—	—
20,000	19,987	25,972	25,993	HK-2020	—	2 320	3 170	5 680	1 890	16 000	—	—
20,638	20,625	26,975	27,000	—	—	—	—	—	—	—	—	—
20,638	20,625	26,975	27,000	—	—	—	—	—	—	—	—	—
20,638	20,625	26,975	27,000	—	—	—	—	—	—	—	—	—
20,638	20,625	26,975	27,000	—	—	—	—	—	—	—	—	—
20,638	20,625	28,562	28,587	—	—	—	—	—	—	—	—	—
20,638	20,625	28,562	28,587	JH-1312	—	2 780	3 810	5 460	3 060	16 000	—	—
22,000	21,987	27,972	27,993	HK-2212	—	1 460	2 010	3 250	1 080	15 000	—	—
22,000	21,987	27,972	27,993	HK-2216	—	1 950	2 680	4 710	1 570	15 000	—	—
22,000	21,987	27,972	27,993	HK-2220	—	2 280	3 130	5 730	1 910	15 000	—	—

Mounting dimensions are based on the inner ring rotating and the outer ring being stationary relative to the load. The housing should be of high strength material. See pages E77-78 for discussion of shaft and housing design.

Drawn cup bearings of nominal inch and metric dimensions with one closed end, which are not tabulated, may be made available upon request.

Caged drawn cup bearings of nominal inch and metric dimensions, with engineered polymer cage, may be made available upon request.

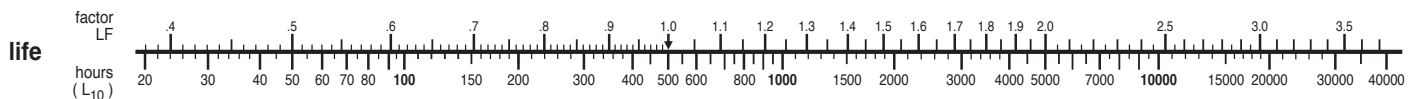

# DRAWN CUP NEEDLE ROLLER BEARINGS

## Full Complement Bearings

Check for availability.

Inch-metric conversions given are for the convenience of the user. The controlling dimensions are in inches for nominal inch bearings and in millimeters for nominal metric bearings.

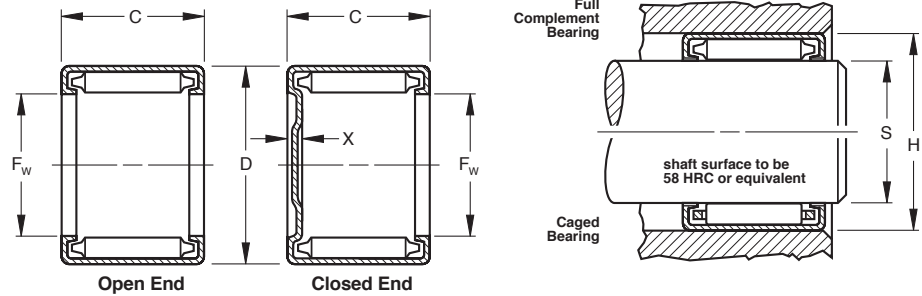

BEARING DIMENSIONS						MECHANICALLY RETAINED ROLLERS						BEARING MOUNTING						
F <sub>w</sub> Bore		D Outside Diameter		C Width		Bearing Designation		Load Ratings				Limiting Speed Full Complement Bearings	X End Thickness	Inch Mounting				
(nom.)		(nom.)		+0.000 -0.010	+0.00 -0.25	open end	closed end	Basic Dynamic C <sub>r</sub>	Basic Static C <sub>0</sub>	Working Load	rpm			(max.)	S Shaft Raceway Diameter		H Housing Bore	
inch	mm	inch	mm	inch	mm			Ⓣ	ISO 281	ISO 76		(max.)				max.	min.	min.
3/8	22.22	1 1/8	28.58	0.375	9.52	B-146	—	1 480	2 280	3 380	1 830	4 800	—	—	0.8750	0.8745	1.1245	1.1255
3/8	22.22	1 1/8	28.58	0.500	12.70	B-148	—	2 190	3 370	5 590	3 030	4 800	—	—	0.8750	0.8745	1.1245	1.1255
3/8	22.22	1 1/8	28.58	0.750	19.05	B-1412	M-14121	3 440	5 300	9 990	5 410	4 800	0.09	2.3	0.8750	0.8745	1.1245	1.1255
3/8	22.22	1 1/8	28.58	1.000	25.40	B-1416	M-14161	4 570	7 040	14 400	7 800	4 800	0.09	2.3	0.8750	0.8745	1.1245	1.1255
3/8	22.22	1 1/8	28.58	1.125	28.58	B-1418	—	5 110	7 860	16 600	8 990	4 800	—	—	0.8750	0.8745	1.1245	1.1255
3/8	22.22	1 3/16	30.16	0.625	15.88	BH-1410	—	2 910	4 470	7 030	3 890	5 880	—	—	0.8750	0.8745	1.1870	1.1880
3/8	22.22	1 3/16	30.16	0.750	19.05	BH-1412	—	3 590	5 530	9 230	5 110	5 880	—	—	0.8750	0.8745	1.1870	1.1880
3/8	22.22	1 3/16	30.16	1.000	25.40	BH-1416	—	4 860	7 480	13 600	7 550	5 880	—	—	0.8750	0.8745	1.1870	1.1880
1/2	23.81	1 3/16	30.16	0.500	12.70	B-158	—	2 270	3 500	5 990	3 220	4 500	—	—	0.9375	0.9370	1.1870	1.1880
1/2	23.81	1 3/16	30.16	1.000	25.40	B-1516	M-15161	4 750	7 300	15 400	8 300	4 500	0.09	2.3	0.9375	0.9370	1.1870	1.1880
0.98	25	1.26	32	0.472	12	—	—	—	—	—	—	—	—	—	0.9843	0.9838	1.2585	1.2595
0.98	25	1.26	32	0.630	16	—	—	—	—	—	—	—	—	—	0.9843	0.9838	1.2585	1.2595
0.98	25	1.26	32	0.787	20	—	—	—	—	—	—	—	—	—	0.9843	0.9838	1.2585	1.2595
0.98	25	1.26	32	1.024	26	—	—	—	—	—	—	—	—	—	0.9842	0.9837	1.2585	1.2595
1	25.40	1 1/4	31.75	0.375	9.52	B-166	—	1 590	2 450	3 870	2 070	4 300	—	—	1.0000	0.9995	1.2495	1.2505
1	25.40	1 1/4	31.75	0.438	11.13	B-167	—	1 980	3 050	5 120	2 740	4 300	—	—	1.0000	0.9995	1.2495	1.2505
1	25.40	1 1/4	31.75	0.500	12.70	B-168	—	2 350	3 620	6 390	3 420	4 300	—	—	1.0000	0.9995	1.2495	1.2505
1	25.40	1 1/4	31.75	0.625	15.88	B-1610	—	3 050	4 690	8 910	4 760	4 300	—	—	1.0000	0.9995	1.2495	1.2505
1	25.40	1 1/4	31.75	0.750	19.05	B-1612	M-16121	3 700	5 690	11 400	6 110	4 300	0.09	2.3	1.0000	0.9995	1.2495	1.2505
1	25.40	1 1/4	31.75	1.000	25.40	B-1616	M-16161	4 910	7 560	16 500	8 800	4 300	0.09	2.3	1.0000	0.9995	1.2495	1.2505
1	25.40	1 1/2	33.34	0.500	12.70	BH-168	MH-1681	2 340	3 600	5 500	3 000	5 200	0.11	2.8	1.0000	0.9995	1.3120	1.3130
1	25.40	1 3/16	33.34	0.625	15.88	BH-1610	—	3 140	4 830	8 020	4 370	5 200	—	—	1.0000	0.9995	1.3120	1.3130
1	25.40	1 3/16	33.34	0.750	19.05	BH-1612	MH-16121	3 880	5 970	10 500	5 750	5 200	0.11	2.8	1.0000	0.9995	1.3120	1.3130
1	25.40	1 3/16	33.34	1.000	25.40	BH-1616	MH-16161	5 260	8 090	15 600	8 500	5 200	0.11	2.8	1.0000	0.9995	1.3120	1.3130
1	25.40	1 3/16	33.34	1.250	31.75	BH-1620	—	6 540	10 100	20 600	11 200	5 200	—	—	1.0000	0.9995	1.3120	1.3130
1	25.40	1 3/16	33.34	1.500	38.10	BH-1624	—	7 750	11 900	25 600	14 000	5 200	—	—	1.0000	0.9995	1.3120	1.3130
1 1/16	26.99	1 3/16	33.34	0.625	15.88	B-1710	—	3 150	4 840	9 470	5 030	4 000	—	—	1.0625	1.0620	1.3120	1.3130
1.10	28	1.38	35	0.630	16	—	—	—	—	—	—	—	—	—	1.1024	1.1019	1.3767	1.3777
1.10	28	1.38	35	0.787	20	—	—	—	—	—	—	—	—	—	1.1024	1.1019	1.3767	1.3777
1 1/8	28.58	1 3/8	34.92	0.375	9.52	B-186	—	1 700	2 610	4 350	2 310	3 800	—	—	1.1250	1.1245	1.3745	1.3755
1 1/8	28.58	1 3/8	34.92	0.500	12.70	B-188	—	2 510	3 850	7 190	3 810	3 800	—	—	1.1250	1.1245	1.3745	1.3755
1 1/8	28.58	1 3/8	34.92	0.750	19.05	B-1812	—	3 940	6 060	12 900	6 810	3 800	—	—	1.1250	1.1245	1.3745	1.3755
1 1/8	28.58	1 3/8	34.92	1.000	25.40	B-1816	M-18161	5 230	8 050	18 500	9 810	3 800	0.09	2.3	1.1250	1.1245	1.3745	1.3755
1 1/8	28.58	1 1/2	38.10	0.750	19.05	BH-1812	—	4 500	6 920	11 500	6 350	5 500	—	—	1.1250	1.1245	1.4995	1.5005
1 1/8	28.58	1 1/2	38.10	1.000	25.40	BH-1816	—	6 120	9 420	17 100	9 430	5 500	—	—	1.1250	1.1245	1.4995	1.5005
1 1/8	28.58	1 1/2	38.10	1.125	28.58	—	—	—	—	—	—	—	—	—	1.1250	1.1245	1.4995	1.5005
1 1/8	28.58	1 1/2	38.10	1.250	31.75	BH-1820	—	7 660	11 800	22 900	12 600	5 500	—	—	1.1250	1.1245	1.4995	1.5005

Ⓣ Symbol denotes Basic Dynamic Load Rating to be used in load-life calculations taking into consideration the application guidelines and limitations given in this catalog.

Load Ratings are based on a minimum raceway hardness of 58 HRC or equivalent. Load ratings are given in pounds-force: 1 lbf = 0.454kgf = 4.448N. Required Basic Dynamic Load Rating (C<sub>r</sub>) = Applied Load • SF • LF • HF (see page E75).

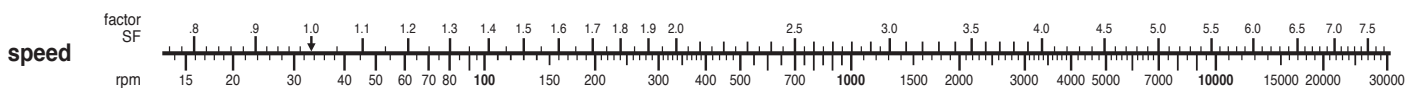

# DRAWN CUP NEEDLE ROLLER BEARINGS

## Caged Bearings

Check for availability.

Inch-metric conversions given are for the convenience of the user. The controlling dimensions are in inches for nominal inch bearings and in millimeters for nominal metric bearings.

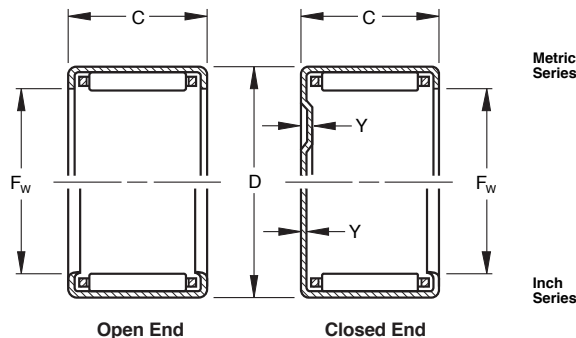

BEARING MOUNTING				CAGE RETAINED ROLLERS								
Metric Mounting				Bearing Designation	Load Ratings				Limiting Speed Caged Bearings	Y End Thickness		
S Shaft Raceway Diameter	H Housing Bore				open end	closed end	Basic Dynamic C <sub>r</sub>	Basic Static C <sub>0</sub>		Working Load		
	millimeters	millimeters					①	ISO 281		ISO 76	(max.)	rpm
max.	min.	min.	max.			lbf	lbf	lbf	lbf			
22,225	22,212	28,562	28,587	J-146	—	1 080	1 480	1 910	1 030	15 000	—	—
22,225	22,212	28,562	28,587	J-148	—	1 640	2 250	3 270	1 770	15 000	—	—
22,225	22,212	28,562	28,587	J-1412	MJ-14121	2 570	3 530	5 830	3 160	15 000	0.04	1.0
22,225	22,212	28,562	28,587	J-1416	MJ-14161	3 540	4 850	8 780	4 750	15 000	0.04	1.0
22,225	22,212	28,562	28,587	—	—	—	—	—	—	—	—	—
22,225	22,212	30,150	30,175	—	—	—	—	—	—	—	—	—
22,225	22,212	30,150	30,175	JH-1412	—	2 710	3 710	5 450	3 020	15 000	—	—
22,225	22,212	30,150	30,175	JH-1416	—	3 770	5 160	8 330	4 610	15 000	—	—
23,812	23,799	30,150	30,175	—	—	—	—	—	—	—	—	—
23,812	23,799	30,150	30,175	—	—	—	—	—	—	—	—	—
25,000	24,987	31,967	31,992	HK-2512	—	1 660	2 270	3 410	1 140	13 000	—	—
25,000	24,987	31,967	31,992	HK-2516	—	2 730	3 240	5 390	1 800	13 000	—	—
25,000	24,987	31,967	31,992	HK-2520	—	3 100	4 250	7 620	2 540	13 000	—	—
25,000	24,987	31,967	31,992	HK-2526	BK-2526	3 860	5 280	10 100	3 370	13 000	.11	2.7
25,400	25,387	31,737	31,762	—	—	—	—	—	—	—	—	—
25,400	25,387	31,737	31,762	—	—	—	—	—	—	—	—	—
25,400	25,387	31,737	31,762	—	—	—	—	—	—	—	—	—
25,400	25,387	31,737	31,762	—	—	—	—	—	—	—	—	—
25,400	25,387	31,737	31,762	J-1612	—	2 710	3 720	6 500	3 470	13 000	—	—
25,400	25,387	31,737	31,762	J-1616	—	3 730	5 110	9 780	5 230	13 000	—	—
25,400	25,387	33,325	33,350	—	—	—	—	—	—	—	—	—
25,400	25,387	33,325	33,350	—	—	—	—	—	—	—	—	—
25,400	25,387	33,325	33,350	JH-1612	MJH-16121	3 060	4 190	6 570	3 590	13 000	0.05	1.3
25,400	25,387	33,325	33,350	JH-1616	MJH-16161	4 090	5 610	9 570	5 220	13 000	0.05	1.3
25,400	25,387	33,325	33,350	—	—	—	—	—	—	—	—	—
25,400	25,387	33,325	33,350	—	—	—	—	—	—	—	—	—
26,988	26,975	33,325	33,350	—	—	—	—	—	—	—	—	—
28,000	27,987	34,967	34,992	HK-2816	—	2 410	3 300	5 690	1 900	12 000	—	—
28,000	27,987	34,967	34,992	HK-2820	—	3 150	4 310	8 040	2 680	12 000	—	—
28,575	28,562	34,912	34,937	—	—	—	—	—	—	—	—	—
28,575	28,562	34,912	34,937	J-188	—	1 790	2 460	3 960	2 100	11 000	—	—
28,575	28,562	34,912	34,937	J-1812	—	2 840	3 890	7 160	3 790	11 000	—	—
28,575	28,562	34,912	34,937	J-1816	—	3 910	5 350	10 800	5 700	11 000	—	—
28,575	28,562	38,087	38,112	JH-1812	—	3 510	4 810	7 120	3 920	12 000	—	—
28,575	28,562	38,087	38,112	JH-1816	MJH-18161	4 970	6 810	11 100	6 140	12 000	0.05	1.3
28,575	28,562	38,087	38,112	JH-1818	—	5 440	7 460	12 500	6 890	12 000	—	—
28,575	28,562	38,087	38,112	—	—	—	—	—	—	—	—	—

Mounting dimensions are based on the inner ring rotating and the outer ring being stationary relative to the load. The housing should be of high strength material. See pages E77-78 for discussion of shaft and housing design.

Drawn cup bearings of nominal inch and metric dimensions with one closed end, which are not tabulated, may be made available upon request.

Caged drawn cup bearings of nominal inch and metric dimensions, with engineered polymer cage, may be made available upon request.

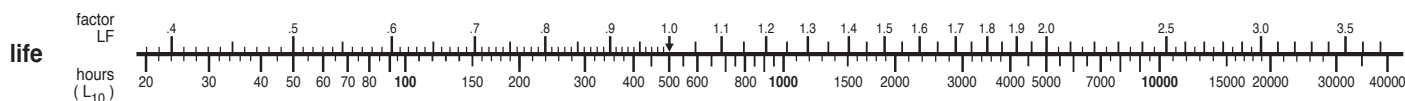

# DRAWN CUP NEEDLE ROLLER BEARINGS

## Full Complement Bearings

Check for availability.

Inch-metric conversions given are for the convenience of the user. The controlling dimensions are in inches for nominal inch bearings and in millimeters for nominal metric bearings.

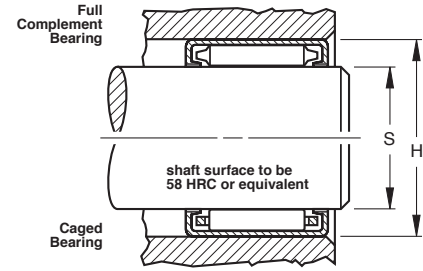
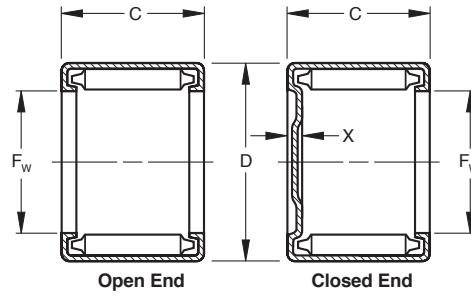

BEARING DIMENSIONS						MECHANICALLY RETAINED ROLLERS						BEARING MOUNTING						
F <sub>w</sub> Bore		D Outside Diameter		C Width		Bearing Designation		Load Ratings			Limiting Speed Full Complement Bearings	X End Thickness	Inch Mounting					
(nom.)		(nom.)		+0.000 -0.010	+0.00 -0.25	open end	closed end	Basic Dynamic C <sub>r</sub>	Basic Static C <sub>0</sub>	Working Load			S Shaft Raceway Diameter	H Housing Bore				
inch	mm	inch	mm	inch	mm			Ⓣ	ISO 281	ISO 76	(max.)	rpm	inch	mm	max.	min.	min.	max.
1.18	30	1.46	37	0.472	12	—	—	—	—	—	—	—	1.1811	1.1806	1.4554	1.4564	1.4554	1.4564
1.18	30	1.46	37	0.787	20	—	—	—	—	—	—	—	1.1811	1.1806	1.4554	1.4564	1.4554	1.4564
1.18	30	1.46	37	1.024	26	—	—	—	—	—	—	—	1.1811	1.1806	1.4554	1.4564	1.4554	1.4564
1 1/16	30.16	1 1/2	38.10	1.000	25.40	<b>B-1916</b>	—	5 760	8 860	18 500	9 920	4 400	—	—	1.1875	1.1870	1.4995	1.5005
1 1/4	31.75	1 1/2	38.10	0.500	12.70	<b>B-208</b>	—	2 650	4 080	7 990	4 200	3 500	—	—	1.2500	1.2495	1.4995	1.5005
1 1/4	31.75	1 1/2	38.10	0.625	15.88	<b>B-2010</b>	—	3 430	5 280	11 100	5 850	3 500	—	—	1.2500	1.2495	1.4995	1.5005
1 1/4	31.75	1 1/2	38.10	0.750	19.05	<b>B-2012</b>	—	4 160	6 410	14 300	7 510	3 500	—	—	1.2500	1.2495	1.4995	1.5005
1 1/4	31.75	1 1/2	38.10	1.000	25.40	<b>B-2016</b>	<b>M-20161</b>	5 530	8 510	20 600	10 800	3 500	0.09	2.3	1.2500	1.2495	1.4995	1.5005
1 1/4	31.75	1 1/2	38.10	1.250	31.75	<b>B-2020</b>	<b>M-20201</b>	6 810	10 500	26 900	14 100	3 500	0.09	2.3	1.2500	1.2495	1.4995	1.5005
1 1/4	31.75	1 5/8	41.28	0.500	12.70	<b>BH-208</b>	—	2 730	4 200	6 320	3 440	5 000	—	—	1.2500	1.2495	1.6245	1.6255
1 1/4	31.75	1 5/8	41.28	0.750	19.05	<b>BH-2012</b>	—	4 720	7 250	12 700	6 930	5 000	—	—	1.2500	1.2495	1.6245	1.6255
1 1/4	31.75	1 5/8	41.28	1.000	25.40	<b>BH-2016</b>	<b>MH-20161</b>	6 440	9 910	19 000	10 400	5 000	0.12	3.0	1.2500	1.2495	1.6245	1.6255
1 1/4	31.75	1 5/8	41.28	1.250	31.75	<b>BH-2020</b>	<b>MH-20201</b>	8 070	12 400	25 400	13 800	5 000	0.12	3.0	1.2500	1.2495	1.6245	1.6255
1 1/16	33.34	1 5/8	41.28	0.500	12.70	<b>B-218</b>	—	2 720	4 180	7 220	3 840	4 000	—	—	1.3125	1.3120	1.6245	1.6255
1 1/16	33.34	1 5/8	41.28	0.625	15.88	<b>B-2110</b>	—	3 640	5 600	10 500	5 600	4 000	—	—	1.3125	1.3120	1.6245	1.6255
1 1/16	33.34	1 5/8	41.28	1.250	31.75	<b>B-2120</b>	—	7 620	11 700	27 200	14 500	4 000	—	—	1.3125	1.3120	1.6245	1.6255
1 3/8	34.92	1 5/8	41.28	0.500	12.70	<b>B-228</b>	—	2 780	4 280	8 790	4 590	3 200	—	—	1.3750	1.3745	1.6245	1.6255
1 3/8	34.92	1 5/8	41.28	0.750	19.05	<b>B-2212</b>	—	4 380	6 730	15 700	8 200	3 200	—	—	1.3750	1.3745	1.6245	1.6255
1 3/8	34.92	1 5/8	41.28	1.000	25.40	<b>B-2216</b>	—	5 820	8 950	22 700	11 800	3 200	—	—	1.3750	1.3745	1.6245	1.6255
1 3/8	34.92	1 5/8	41.28	1.250	31.75	<b>B-2220</b>	—	7 160	11 000	29 600	15 400	3 200	—	—	1.3750	1.3745	1.6245	1.6255
1 3/8	34.92	1 3/4	44.45	0.625	15.88	<b>BH-2210</b>	—	4 060	6 240	10 600	5 740	4 700	—	—	1.3750	1.3745	1.7495	1.7505
1 3/8	34.92	1 3/4	44.45	0.750	19.05	<b>BH-2212</b>	—	5 050	7 770	14 100	7 610	4 700	—	—	1.3750	1.3745	1.7495	1.7505
1 3/8	34.92	1 3/4	44.45	1.000	25.40	<b>BH-2216</b>	—	6 870	10 600	20 900	11 300	4 700	—	—	1.3750	1.3745	1.7495	1.7505
1 3/8	34.92	1 3/4	44.45	1.250	31.75	<b>BH-2220</b>	—	8 600	13 200	28 000	15 100	4 700	—	—	1.3750	1.3745	1.7495	1.7505
1.38	35	1.65	42	0.472	12	—	—	—	—	—	—	—	1.3779	1.3774	1.6522	1.6532	1.6522	1.6532
1.38	35	1.65	42	0.630	16	—	—	—	—	—	—	—	1.3780	1.3774	1.6522	1.6532	1.6522	1.6532
1.38	35	1.65	42	0.787	20	—	—	—	—	—	—	—	1.3780	1.3774	1.6522	1.6532	1.6522	1.6532
1 1/2	38.10	1 5/8	47.62	0.500	12.70	<b>B-248</b>	—	3 110	4 780	7 830	4 190	4 300	—	—	1.5000	1.4995	1.8745	1.8755
1 1/2	38.10	1 5/8	47.62	0.625	15.88	<b>B-2410</b>	—	4 220	6 500	11 600	6 200	4 300	—	—	1.5000	1.4995	1.8745	1.8755
1 1/2	38.10	1 5/8	47.62	0.750	19.05	<b>B-2412</b>	—	5 260	8 090	15 400	8 220	4 300	—	—	1.5000	1.4995	1.8745	1.8755
1 1/2	38.10	1 5/8	47.62	0.875	22.22	<b>B-2414</b>	—	6 240	9 590	19 200	10 200	4 300	—	—	1.5000	1.4995	1.8745	1.8755
1 1/2	38.10	1 5/8	47.62	1.000	25.40	<b>B-2416</b>	<b>M-24161</b>	7 150	11 000	22 800	12 200	4 300	0.12	3.0	1.5000	1.4995	1.8745	1.8755
1 1/2	38.10	1 5/8	47.62	1.250	31.75	<b>B-2420</b>	<b>M-24201</b>	8 950	13 800	30 500	16 300	4 300	0.12	3.0	1.5000	1.4995	1.8745	1.8755
1.57	40	1.85	47	0.472	12	—	—	—	—	—	—	—	1.5748	1.5742	1.8491	1.8501	1.8491	1.8501
1.57	40	1.85	47	0.630	16	—	—	—	—	—	—	—	1.5748	1.5742	1.8491	1.8501	1.8491	1.8501
1.57	40	1.85	47	0.787	20	—	—	—	—	—	—	—	1.5748	1.5742	1.8491	1.8501	1.8491	1.8501

Ⓣ Symbol denotes Torrington Basic Dynamic Load Rating to be used in load-life calculations taking into consideration the application guidelines and limitations given in this catalog. Applications involving loads approaching this rating or the tabulated working load, whichever is the smaller, should be referred to the Torrington Engineering Sales Office before a final selection is made.

Load Ratings are based on a minimum raceway hardness of 58 HRC or equivalent. Load ratings are given in pounds-force: 1 lbf = 0.454kgf = 4.448N. Required Basic Dynamic Load Rating (Cr) = Applied Load • SF • LF • HF (see page E75).

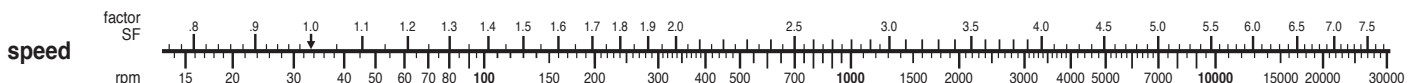

# DRAWN CUP NEEDLE ROLLER BEARINGS

## Caged Bearings

Check for availability.

Inch-metric conversions given are for the convenience of the user. The controlling dimensions are in inches for nominal inch bearings and in millimeters for nominal metric bearings.

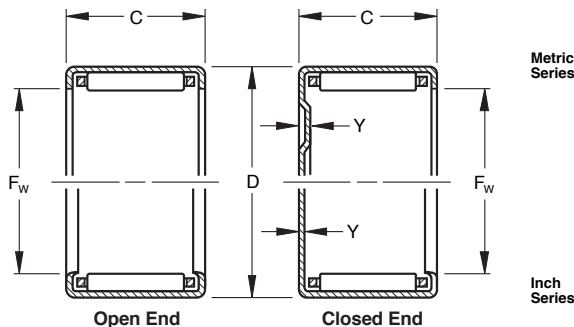

BEARING MOUNTING				CAGE RETAINED ROLLERS								
Metric Mounting				Bearing Designation	Load Ratings				Limiting Speed Caged Bearings	Y End Thickness		
S Shaft Raceway Diameter		H Housing Bore			Basic Dynamic $C_r$	Basic Static $C_o$	Working Load	Y End Thickness				
max.	min.	min.	max.					open end		closed end	inch	mm
30,000	29,987	36,967	36,992	HK-3012	—	1 830	2 500	4 100	1 370	11 000	—	—
30,000	29,987	36,967	36,992	HK-3020	—	3 410	4 680	9 140	3 050	11 000	—	—
30,000	29,987	36,967	36,992	HK-3026	—	4 120	5 640	11 600	3 870	11 000	—	—
30,162	30,149	38,087	38,112	—	—	—	—	—	—	—	—	—
31,750	31,737	38,087	38,112	—	—	—	—	—	—	—	—	—
31,750	31,737	38,087	38,112	—	—	—	—	—	—	—	—	—
31,750	31,737	38,087	38,112	—	—	—	—	—	—	—	—	—
31,750	31,737	38,087	38,112	J-2016	MJ-20161	4 310	5 900	12 700	6 650	10 000	—	—
31,750	31,737	38,087	38,112	—	—	—	—	—	—	—	—	—
31,750	31,737	41,262	41,287	—	—	—	—	—	—	—	—	—
31,750	31,737	41,262	41,287	JH-2012	—	3 620	4 960	7 710	4 190	10 000	—	—
31,750	31,737	41,262	41,287	JH-2016	—	5 090	6 970	11 900	6 490	10 000	—	—
31,750	31,737	41,262	41,287	JH-2020	—	6 370	8 730	15 900	8 660	10 000	—	—
33,338	33,325	41,262	41,287	—	—	—	—	—	—	—	—	—
33,338	33,325	41,262	41,287	—	—	—	—	—	—	—	—	—
33,338	33,325	41,262	41,287	—	—	—	—	—	—	—	—	—
34,925	34,912	41,262	41,287	J-228	—	2 090	2 870	5 170	2 700	9 200	—	—
34,925	34,912	41,262	41,287	J-2212	—	3 410	4 670	9 690	4 890	9 200	—	—
34,925	34,912	41,262	41,287	—	—	—	—	—	—	—	—	—
34,925	34,912	41,262	41,287	—	—	—	—	—	—	—	—	—
34,925	34,912	44,437	44,462	—	—	—	—	—	—	—	—	—
34,925	34,912	44,437	44,462	JH-2212	—	3 950	5 410	8 740	4 720	9 400	—	—
34,925	34,912	44,437	44,462	JH-2216	MJH-22161	5 480	7 510	13 300	7 190	9 400	0.05	1.3
34,925	34,912	44,437	44,462	—	—	—	—	—	—	—	—	—
35,000	34,987	41,967	41,992	HK-3512	—	2 040	2 790	4 950	1 650	9 100	—	—
35,000	34,987	41,967	41,992	HK-3516	—	2 630	3 600	6 840	2 280	9 100	—	—
35,000	34,987	41,967	41,992	HK-3520	—	3 700	5 070	10 700	3 570	9 100	—	—
38,100	38,087	47,612	47,637	—	—	—	—	—	—	—	—	—
38,100	38,087	47,612	47,637	—	—	—	—	—	—	—	—	—
38,100	38,087	47,612	47,637	J-2412	—	4 260	5 830	9 970	5 330	8 600	—	—
38,100	38,087	47,612	47,637	—	—	—	—	—	—	—	—	—
38,100	38,087	47,612	47,637	J-2416	—	5 890	8 080	15 100	8 100	8 600	—	—
38,100	38,087	47,612	47,637	J-2420	—	7 410	10 200	20 300	10 900	8 600	—	—
40,000	39,984	46,967	46,992	HK-4012	—	2 040	2 800	5 170	1 720	7 900	—	—
40,000	39,984	46,967	46,992	HK-4016	—	2 860	3 910	7 960	2 650	7 900	—	—
40,000	39,984	46,967	46,992	HK-4020	—	3 790	5 190	11 500	3 830	7 900	—	—

Mounting dimensions are based on the inner ring rotating and the outer ring being stationary relative to the load. The housing should be of high strength material. See pages E77-E78 for discussion of shaft and housing design.

Drawn cup bearings of nominal inch and metric dimensions with one closed end, which are not tabulated, may be made available upon request.

Caged drawn cup bearings of nominal inch and metric dimensions, with engineered polymer cage, may be made available upon request.

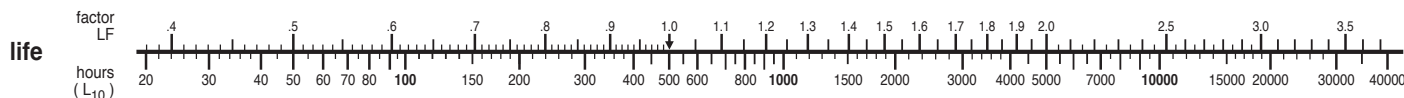



# DRAWN CUP NEEDLE ROLLER BEARINGS

## Full Complement Bearings

Check for availability.

Inch-metric conversions given are for the convenience of the user. The controlling dimensions are in inches for nominal inch bearings and in millimeters for nominal metric bearings.

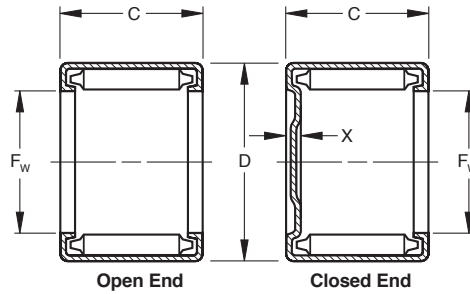

BEARING DIMENSIONS						MECHANICALLY RETAINED ROLLERS						BEARING MOUNTING						
F <sub>w</sub> Bore  (nom.)	D Outside Diameter  (nom.)		C Width  +0.000 -0.010		Bearing Designation  open end closed end	Load Ratings				Limiting Speed Full Comple- ment Bearings  rpm	X End Thickness  (max.)		Inch Mounting					
	inch	mm	inch	mm		Basic Dynamic C <sub>r</sub>  Ⓟ	Basic Static C <sub>0</sub>  ISO 281	Working Load  ISO 76  (max.)	inch		mm	S Shaft Raceway Diameter  inches		H Housing Bore  inches				
												max.	min.	min.	max.			
1 1/8	41.28	2	50.8	0.500	12.70	B-268	—	3 200	4 920	8 390	4 450	3 900	—	—	1.6250	1.6245	1.9995	2.0005
1 1/8	41.28	2	50.8	0.625	15.88	B-2610	—	4 360	6 710	12 500	6 630	3 900	—	—	1.6250	1.6245	1.9995	2.0005
1 1/8	41.28	2	50.80	1.000	25.40	B-2616	—	7 430	11 400	24 800	13 100	3 900	—	—	1.6250	1.6245	1.9995	2.0005
1 1/8	41.28	2	50.80	1.250	31.75	B-2620	—	9 280	14 300	33 000	17 500	3 900	—	—	1.6250	1.6245	1.9995	2.0005
1 3/8	44.45	2 1/2	53.98	0.750	19.05	B-2812	—	5 630	8 660	17 900	9 410	3 700	—	—	1.7500	1.7495	2.1245	2.1255
1 3/8	44.45	2 1/2	53.98	1.000	25.40	B-2816	M-28161	7 690	11 800	26 700	14 100	3 700	0.12	3.0	1.7500	1.7495	2.1245	2.1255
1 3/8	44.45	2 1/2	53.98	1.250	31.75	B-2820	—	9 600	14 800	35 500	18 700	3 700	—	—	1.7500	1.7495	2.1245	2.1255
1 3/8	44.45	2 1/2	53.98	1.500	38.10	B-2824	—	11 400	17 600	44 300	23 400	3 700	—	—	1.7500	1.7495	2.1245	2.1255
1.77	45	2.05	52	0.472	12	—	—	—	—	—	—	—	—	—	1.7717	1.7711	2.0457	2.0469
1.77	45	2.05	52	0.630	16	—	—	—	—	—	—	—	—	—	1.7717	1.7711	2.0457	2.0469
1.77	45	2.05	52	0.787	20	—	—	—	—	—	—	—	—	—	1.7717	1.7711	2.0457	2.0469
1 7/8	47.62	2 1/4	57.15	0.500	12.70	B-308	—	3 500	5 380	9 790	5 140	3 500	—	—	1.8750	1.8745	2.2495	2.2505
1 7/8	47.62	2 1/4	57.15	0.750	19.05	B-3012	—	5 920	9 100	19 200	10 100	3 500	—	—	1.8750	1.8745	2.2495	2.2505
1 7/8	47.62	2 1/4	57.15	1.000	25.40	B-3016	—	8 050	12 400	28 600	15 000	3 500	—	—	1.8750	1.8745	2.2495	2.2505
1.97	50	2.28	58	0.787	20	—	—	—	—	—	—	—	—	—	1.9685	1.9679	2.2819	2.2831
2	50.80	2 3/8	60.32	0.500	12.70	B-328	—	3 570	5 490	10 300	5 390	3 300	—	—	2.0000	1.9994	2.3745	2.3755
2	50.80	2 3/8	60.32	1.000	25.40	B-3216	M-32161	8 290	12 700	30 500	15 900	3 300	0.12	3.0	2.0000	1.9994	2.3745	2.3755
2	50.80	2 3/8	60.32	1.250	31.75	B-3220	—	10 300	15 900	40 600	21 200	3 300	—	—	2.0000	1.9994	2.3745	2.3755
2	50.80	2 3/8	60.32	1.750	44.45	B-3228	M-32281	14 200	21 800	60 700	31 700	3 300	0.12	3.0	2.0000	1.9994	2.3745	2.3755
2 1/16	52.39	2 11/32	64.29	0.750	19.05	BH-3312	—	6 590	10 100	19 000	10 100	4 000	—	—	2.0625	2.0619	2.5307	2.5317
2 1/16	52.39	2 11/32	64.29	1.000	25.40	BH-3316	—	9 250	14 200	29 400	15 600	4 000	—	—	2.0625	2.0619	2.5307	2.5317
2 1/8	53.98	2 1/2	63.50	0.500	12.70	B-348	—	3 670	5 650	11 000	5 710	3 100	—	—	2.1250	2.1244	2.4995	2.5005
2 1/8	53.98	2 1/2	63.50	1.000	25.40	B-3416	—	8 530	13 100	32 400	16 900	3 100	—	—	2.1250	2.1244	2.4995	2.5005
2 1/8	53.98	2 1/2	63.50	1.500	38.10	B-3424	—	12 700	19 500	53 900	28 000	3 100	—	—	2.1250	2.1244	2.4995	2.5005
2.17	55	2.48	63	0.787	20	—	—	—	—	—	—	—	—	—	2.1654	2.1647	2.4788	2.4800
2 1/4	57.15	2 5/8	66.68	0.750	19.05	B-3612	—	6 590	10 100	23 100	12 000	3 000	—	—	2.2500	2.2494	2.6245	2.6255
2 1/4	57.15	2 5/8	66.68	1.000	25.40	—	—	—	—	—	—	—	—	—	2.2500	2.2494	2.6245	2.6255
2 1/4	57.15	2 5/8	66.68	1.250	31.75	B-3620	—	11 200	17 300	45 800	23 800	3 000	—	—	2.2500	2.2494	2.6245	2.6255
2 1/4	57.15	2 5/8	66.68	1.500	38.10	B-3624	—	13 300	20 500	57 200	29 700	3 000	—	—	2.2500	2.2494	2.6245	2.6255
2.36	60	2.68	68	0.472	12	—	—	—	—	—	—	—	—	—	2.3622	2.3618	2.7150	2.7162
2 3/8	66.68	3	76.20	1.000	25.40	B-4216	M-42161	9 590	14 800	40 100	20 600	2 500	0.13	3.3	2.6250	2.6244	2.9995	3.0005
2 3/4	69.85	3 1/8	79.38	0.625	15.88	B-4410	—	5 840	8 980	21 300	10 900	2 500	—	—	2.7500	2.7494	3.1245	3.1255
2 3/4	69.85	3 1/8	79.38	0.750	19.05	—	—	—	—	—	—	—	—	—	2.7500	2.7494	3.1245	3.1255
2 3/4	69.85	3 1/8	79.38	1.000	25.40	B-4416	—	9 920	15 300	42 100	21 600	2 500	—	—	2.7500	2.7494	3.1245	3.1255
2 3/4	69.85	3 1/8	79.38	1.250	31.75	B-4420	—	12 400	19 000	56 000	28 700	2 500	—	—	2.7500	2.7494	3.1245	3.1255
3 1/2	88.90	4	101.60	0.750	19.05	B-5612	—	9 310	14 300	32 800	16 900	2 700	—	—	3.5000	3.4994	3.9995	4.0005
5 1/2	139.7	6	152.40	0.750	19.05	B-8812	—	10 900	16 700	49 900	25 100	1 600	—	—	5.5000	5.4993	5.9990	6.0010

Ⓟ Symbol denotes Basic Dynamic Load Rating to be used in load-life calculations taking into consideration the application guidelines and limitations given in this catalog.

Load Ratings are based on a minimum raceway hardness of 58 HRC or equivalent. Load ratings are given in pounds-force: 1 lbf = 0.454kgf = 4.448N. Required Basic Dynamic Load Rating (Cr) = Applied Load • SF • LF • HF (see page E75).

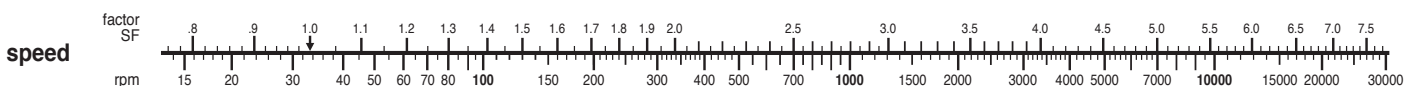

# DRAWN CUP NEEDLE ROLLER BEARINGS

## Caged Bearings

Inch-metric conversions given are for the convenience of the user. The controlling dimensions are in inches for nominal inch bearings and in millimeters for nominal metric bearings.

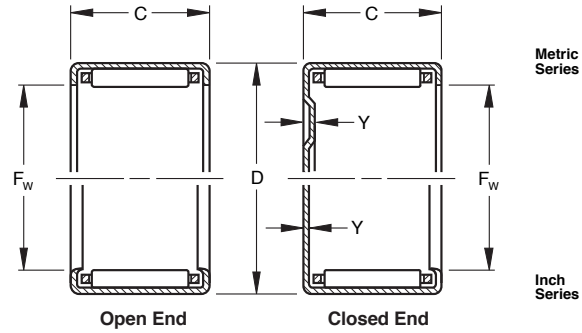

BEARING MOUNTING				CAGE RETAINED ROLLERS							
Metric Mounting				Bearing Designation	Load Ratings				Limiting Speed Caged Bearings	Y End Thickness	
S Shaft Raceway Diameter		H Housing Bore			Basic Dynamic $C_r$	Basic Static $C_o$	Working Load	rpm		mm	
max.	min.	min.	max.							inch	mm
41,275	41,262	50,787	50,812	—	—	—	—	—	—	—	
41,275	41,262	50,787	50,812	<b>J-2610</b>	3 930	5 390	9 620	4 930	7 900	—	
41,275	41,262	50,787	50,812	<b>J-2616</b>	5 890	8 060	15 600	8 280	7 900	—	
41,275	41,262	50,787	50,812	—	—	—	—	—	—	—	
44,450	44,437	53,962	53,987	<b>J-2812</b>	4 440	6 080	11 200	5 890	7 300	—	
44,450	44,437	53,962	53,987	<b>J-2816</b>	6 000	8 230	16 500	8 690	7 300	—	
44,450	44,437	53,962	53,987	—	—	—	—	—	—	—	
44,450	44,437	53,962	53,987	<b>J-2824</b>	8 940	12 200	27 500	14 500	7 300	—	
45,000	44,984	51,961	51,991	<b>HK-4512</b>	2 140	2 670	5 720	1 910	7 000	—	
45,000	44,984	51,961	51,991	<b>FJ-4516</b>	3 490	4 780	10 300	3 430	7 000	—	
45,000	44,984	51,961	51,991	<b>HK-4520</b>	3 960	5 430	12 600	4 200	7 000	—	
47,625	47,612	57,137	57,162	—	—	—	—	—	—	—	
47,625	47,612	57,137	57,162	—	—	—	—	—	—	—	
47,625	47,612	57,137	57,162	<b>J-3016</b>	6 160	8 440	17 200	9 040	6 800	—	
50,000	49,984	57,961	57,991	<b>FJ-5020</b>	4 760	6 520	14 100	4 700	6 300	—	
50,800	50,785	60,312	60,337	—	—	—	—	—	—	—	
50,800	50,785	60,312	60,337	<b>J-3216</b>	6 350	8 700	18 400	9 600	6 300	—	
50,800	50,785	60,312	60,337	—	—	—	—	—	—	—	
50,800	50,785	60,312	60,337	—	—	—	—	—	—	—	
52,388	52,373	64,280	64,305	—	—	—	—	—	—	—	
52,388	52,373	64,280	64,305	—	—	—	—	—	—	—	
53,975	53,960	63,487	63,512	—	—	—	—	—	—	—	
53,975	53,960	63,487	63,512	—	—	—	—	—	—	—	
53,975	53,960	63,487	63,512	—	—	—	—	—	—	—	
55,000	54,981	62,961	62,991	<b>FJ-5520</b>	5 000	6 850	15 500	8 040	5 700	—	
57,150	57,135	66,662	66,687	<b>J-3612</b>	5 110	7 000	14 200	7 360	5 600	—	
57,150	57,135	66,662	66,687	<b>J-3616</b>	6 930	9 490	20 900	10 900	5 600	—	
57,150	57,135	66,662	66,687	—	—	—	—	—	—	—	
57,150	57,135	66,662	66,687	—	—	—	—	—	—	—	
60,000	59,991	68,961	68,991	<b>HK-6012</b>	2 690	3 680	7 410	2 470	5 200	—	
66,675	66,660	76,187	76,212	—	—	—	—	—	—	—	
69,850	69,835	79,362	79,387	—	—	—	—	—	—	—	
69,850	69,835	79,362	79,387	<b>J-4412</b>	5 460	7 480	16 000	8 520	4 500	—	
69,850	69,835	79,362	79,387	—	—	—	—	—	—	—	
69,850	69,835	79,362	79,387	—	—	—	—	—	—	—	
88,900	88,885	101,587	101,612	—	—	—	—	—	—	—	
139,700	139,682	152,375	152,426	—	—	—	—	—	—	—	

Mounting dimensions are based on the inner ring rotating and the outer ring being stationary relative to the load. The housing should be of high strength material. See pages E77- E78 for discussion of shaft and housing design.

Drawn cup bearings of nominal inch and metric dimensions with one closed end, which are not tabulated, may be made available upon request.

Caged drawn cup bearings of nominal inch and metric dimensions, with engineered polymer cage, may be made available upon request.

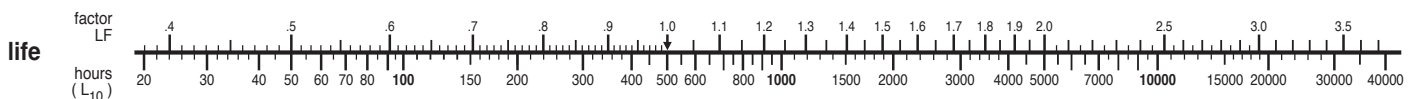



# PIB

## Drawn Cup Roller Clutches

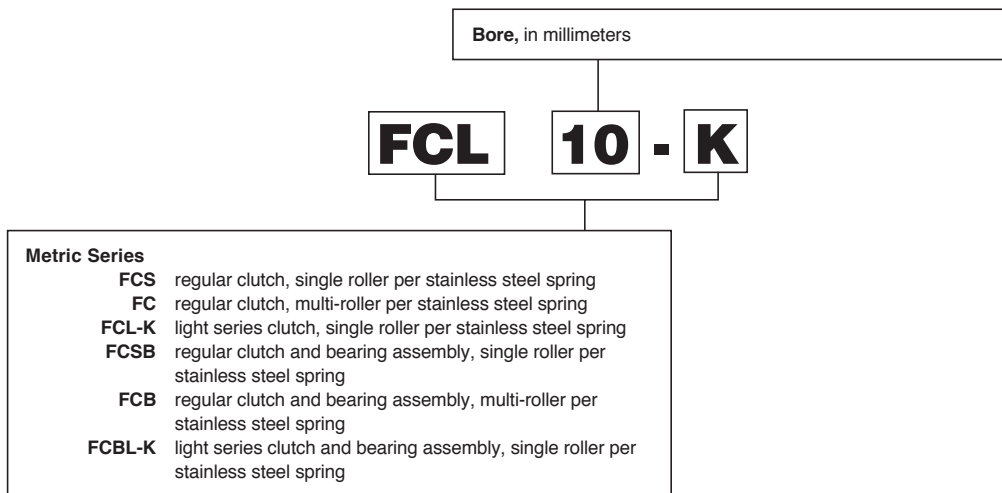
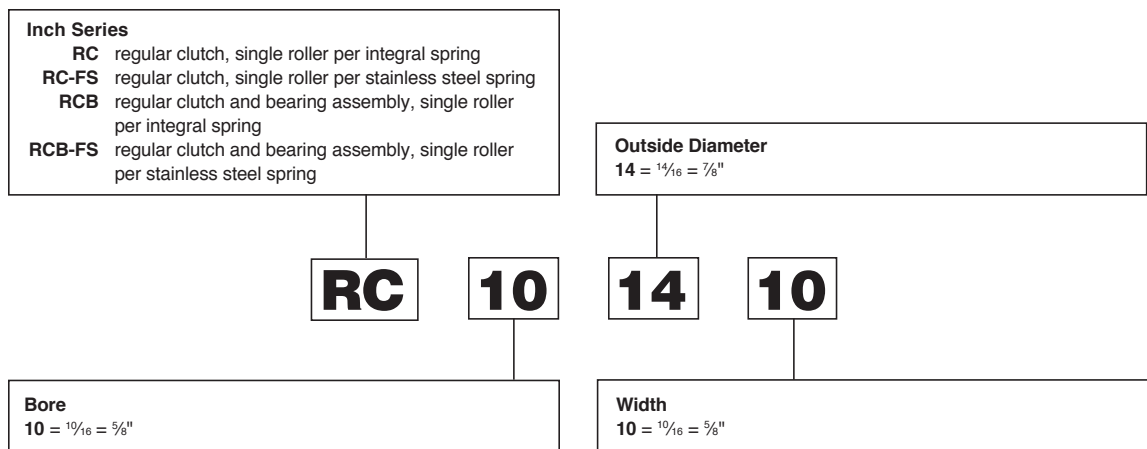

# ***DRAWN CUP ROLLER CLUTCHES***

---

	<b>Page</b>		<b>Page</b>
Introduction .....	494	Temperatures .....	499
Design .....	494	Backlash .....	499
Operation .....	494	Rate of Engagement .....	499
Identification .....	495	Overrun Limit Speed .....	499
Construction .....	495	Inspection .....	499
Special Clutches .....	495		
Application .....	496-497	<b>DC ROLLER CLUTCHES</b>	
Housing Design .....	497	Types FC, FCS, FCL-K, RC-FS and RC	
Shaft Design .....	497	Dimensions, Ratings, Gauging and Mounting .....	500-501
Installation .....	498		
Applied Loads .....	499	<b>DC ROLLER CLUTCH AND BEARING ASSEMBLIES</b>	
Lubrication .....	499	Types FCB, FCBL-K, RCB-FS and RCB	
		Dimensions, Ratings, Gauging and Mounting .....	502-503

# DRAWN CUP ROLLER CLUTCHES

## INTRODUCTION

### Function

The drawn cup roller clutch transmits torque between the shaft and housing in one direction and allows free overrun in the opposite direction. When transmitting torque, either the shaft or the housing can be the input member. Applications are generally described as indexing, backstopping or overrunning.

### Lock Function

Shaft Drives Gear

Clockwise ( White arrows )

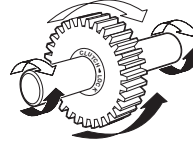

or Gear Can Drive Shaft Counter-Clockwise  
( Black arrows )

### Overrun Function

Shaft Overruns In Gear

Counter-Clockwise ( White arrows )

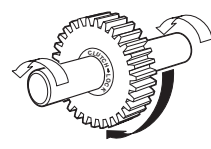

or Gear Overruns on Shaft Clockwise  
( Black arrow )

## DESIGN

The patented design utilizes the same low profile radial section as drawn cup needle roller bearings. The units are compact, light in weight and operate directly on a hardened shaft. Proper mounting is easily accomplished with a simple press fit in the housing.

Precisely formed interior ramps provide surfaces against which the rollers wedge to positively lock the clutch with the shaft when rotated in the proper direction. Transition from the overrun to locked operation normally occurs with minimal lost motion (backlash).

Two basic configurations are produced:

**clutch only** - Use with external radial support (usually two drawn cup needle roller bearings). Separate bearings position the shaft and housing concentrically and carry the radial load during overrun.



Clutch Only

**clutch and bearing assemblies** - Use without additional radial support. An integral assembly within a single drawn cup, in which two roller bearings straddle the clutch.

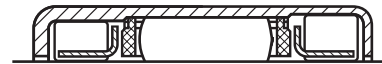

Clutch and Bearing Assembly

## OPERATION

Operation is in two modes; the **overrun** mode and the **lock** mode. Operational mode is controlled by the direction of the clutch or shaft rotation with respect to the locking ramps.

In the **overrun** mode shown in the drawings below, the relative rotation between the housed clutch and the shaft causes the rollers to move away from their locking position against the locking ramps in the drawn cup. The housing and the clutch are thus free to overrun in one direction, or the shaft is free to overrun in the other direction.

In the **lock** mode shown in the drawings below, the relative rotation between the housed clutch and the shaft is opposite to that in the overrun mode. The rollers, assisted by the leaf type springs, become wedged between the locking ramps and the shaft to transmit torque between the two members. Either the member housing the clutch drives the shaft in one direction, or the shaft can drive the clutch and its housing member in the other direction.

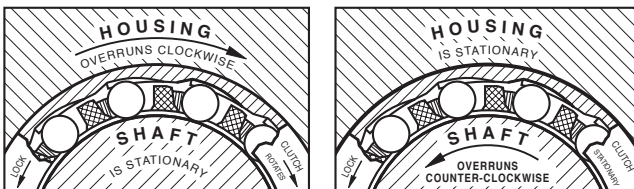

Clearance between the rollers and cup ramps is exaggerated in these drawings.

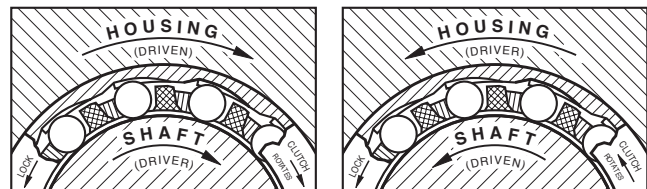

# DRAWN CUP ROLLER CLUTCHES

## IDENTIFICATION

The prefix letters in the designation of the drawn cup roller clutches and drawn cup roller clutch and bearing assemblies denote whether these are manufactured to inch or metric nominal dimensions. Designation codes for clutches and clutch and bearing assemblies with inch nominal dimensions begin with the letter "R". Those for clutches and clutch and bearing assemblies with metric nominal dimensions begin with the letter "F".

The basic types of clutches and clutch and bearing assemblies are listed below:

### Inch Series

- RC** – regular clutch, single roller per integral spring
- RC-FS** – regular clutch, single roller per stainless steel spring
- RCB** – regular clutch and bearing assembly, single roller per integral spring
- RCB-FS** – regular clutch and bearing assembly, single roller per stainless steel spring

### Metric Series

- FCS** – regular clutch, single roller per stainless steel spring
- FC** – regular clutch, multi-roller per stainless steel spring
- FCL-K** – light series clutch, single roller per stainless steel spring
- FCSB** – regular clutch and bearing assembly, single roller per stainless steel spring
- FCB** – regular clutch and bearing assembly, multi-roller per stainless steel spring
- FCBL-K** – light series clutch and bearing assembly, single roller per stainless steel spring

## CONSTRUCTION

In many respects, construction is similar to that of drawn cup bearings. Design and manufacture of drawn cup clutches, just as with drawn cup bearings, was pioneered and developed by.

The interior ramps which control the lockup and free run of the clutch are formed during the operation of drawing the cup. The ramps are case hardened to assure long wear life. The incorporation of ramp forming into the cup drawing operation is a manufacturing innovation that contributes much to the units low cost.

Two types of precision molded clutch cages are employed. Types RC and RCB utilize a one-piece cage of acetal resin plastic with integral leaf style springs. Types FC, FCS, FCL-K, RC-FS, FCB, FCBL-K and RCB-FS use a glass fiber reinforced nylon cage equipped with inserted stainless steel leaf springs. The stainless steel springs permit higher rates of engagement, and achieve a greater spring life. The nylon cage permits operation at higher temperatures than the acetal resin cage.

Types RCB, FCB, FCBL-K and RCB-FS clutch and bearing assemblies have cages for retention and guidance of the rollers in the bearings located on both sides of the clutch unit.



**Drawn Cup Roller Clutch  
Type FC  
with Steel Springs**



**Drawn Cup Clutch and  
Bearing Assembly  
Type FCB  
with Steel Springs**



**Drawn Cup Roller Clutch  
Types FCS, FCL-K and RC-FS  
with Steel Springs**



**Drawn Cup Clutch and  
Bearing Assembly  
Types FCBL-K  
and RCB-FS  
with Steel Springs**



**Drawn Cup Roller Clutch  
Type RC  
with Integral Springs**



**Drawn Cup Clutch and  
Bearing Assembly Type RCB  
with Integral Springs**

## SPECIAL CLUTCHES

Where volume justifies tooling costs, special clutches may result in a lower unit cost or, in the event of additional costs, may provide an economical solution to an unusual design problem.

## APPLICATION

Both clutches and clutch and bearing assemblies are successfully applied in a wide range of commercial products where indexing, backstopping and overrunning operations must be performed reliably. The sketches on these pages illustrate some of the many possible uses.

When applying the clutch-only unit, separate bearings on each side of the clutch are required to position the shaft concentrically with the housing and to carry the radial loads during overrun. Drawn cup needle roller bearings with the same radial section as the clutch should be used in the through bored housings for simplicity and economy. Two clutches can be used side by side for greater torque capacity.

Where the radial loads are light, the clutch and bearing assembly can be used without additional support bearings. This reduces the overall assembly width, the number of stocked and ordered parts, and assembly costs as well.

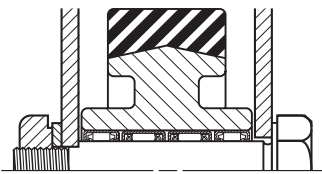

**Clutch and Bearing Arrangement  
Heavy Loads**

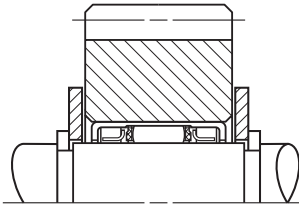

**Clutch and Bearing Assembly  
Light Loads**

Drawn Cup Roller Clutches are manufactured to commercial hardware standards and are used extensively in appliances, business machines, industrial and recreation equipment and a wide range of other applications.

In any application where our clutch may be considered, it will be part of a system in which the operating conditions and the clutch mounting will affect its function. Therefore, before any clutch selection is made, it is important that the following catalog section be carefully studied to understand the effects of these factors.

Consideration should be given to operating conditions such as:

- Magnitude of externally applied torque as well as inertial torque
- Magnitude of applied radial loads during overrunning
- Potential for vibration or axial shaft movement within the clutch during engagement
- Engagement rate, as it pertains to the selection of stainless steel or plastic leaf springs
- Oil lubrication supply during high overrunning speeds
- External and internal environmental temperatures that can affect clutch performance
- Lubricant selection effect on clutch engagement
- Indexing inaccuracies resulting from backlash (lost motion)

Consideration should be given to the Shaft and Housing design requirements such as:

- Shaft hardness and strength particularly when approaching torque rating limits
- Shaft roundness, taper and surface finish necessary to ensure sufficient fatigue life and torque carrying ability
- Housing strength (hardness and cross section) to support the applied torque loads
- Housing roundness, taper and surface finish necessary to ensure uniform torque and load distribution

**Stair Steppers  
Nordic Trak and other  
Athletic Equipment**

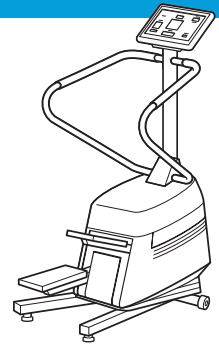

**Lawnmower  
Differential**

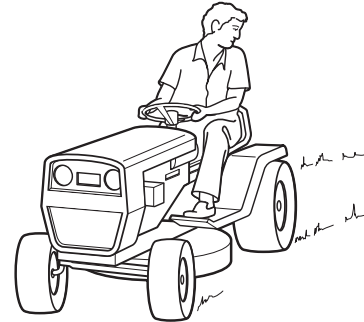

**Tape Dispensers  
and Similar  
Web Roll Feed  
Mechanisms**

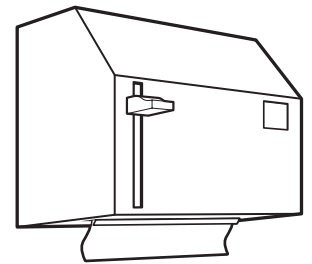

**Conveyor  
Rollers**

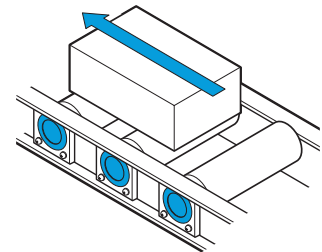

**Chainsaw Starters**

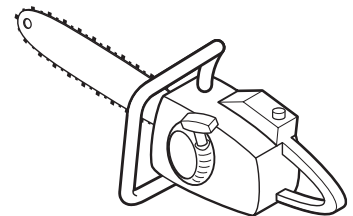

**Paper  
Feed Rolls  
in Business  
Machines**

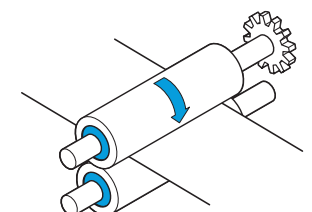

# DRAWN CUP ROLLER CLUTCHES

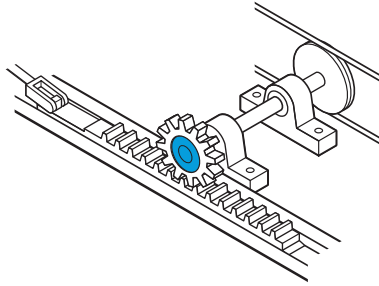

Rack Indexing Drive

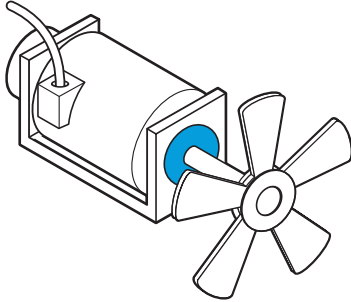

Motor Backstops

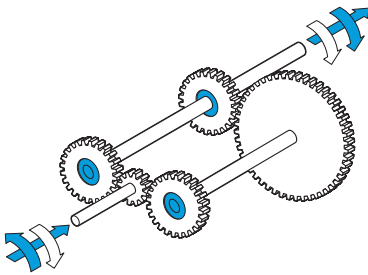

2-Speed Gearbox with Reversing Input

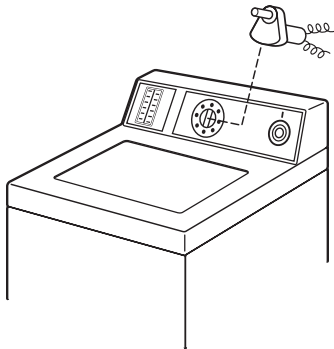

Timing Motor Freewheels

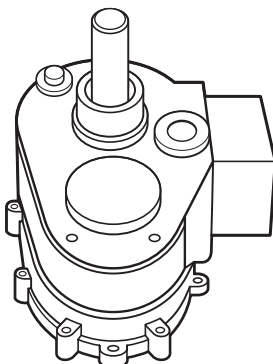

Washing Machine Transmission

## HOUSING DESIGN

Drawn cup clutches and clutch and bearing assemblies are mounted with a simple press fit in their housings. Through bored and chamfered housings are preferred. Provisions for axial location, such as shoulders or snap rings, are not required. The case hardened cups have a long fatigue life, but must be properly supported to realize this benefit. Steel housings are preferred and must be used for applications involving high torque loads to prevent radial expansion of the clutch cups. The recommended minimum housing outside diameters in the tables of dimensions are for steel.

The housing bore should be round within one-half of the diameter tolerance.

The taper within the length of the outer ring should not exceed 0.0005 inch or 0.013 mm.

The surface finish of the housing bore should not exceed 125 microinches, a.a. (arithmetic average) or 3.2 $\mu$ m (on the R<sub>a</sub> scale).

Low strength housings (non-steel, sintered metals and some plastics) may be entirely satisfactory in lightly loaded applications. When using non-steel housings, thoroughly test designs.

Adhesive compounds can be used to prevent creeping rotation of the clutch in plastic housings with low friction properties. Adhesives will not provide proper support in oversized metallic housings. When using adhesives, care must be taken to keep the adhesive out of the clutches and bearings.

## SHAFT DESIGN

The clutch or clutch and bearing assembly operates directly on the shaft whose specifications of dimensions, hardness and surface finish are well within standard manufacturing limits.

Either case hardening or through hardening grades of good bearing quality steel are satisfactory for raceways. Steels which are modified for free machining, such as those high in sulfur content and particularly those containing lead, are seldom satisfactory for raceways.

For long fatigue life, the shaft raceway, must have a hardness equivalent to 58 HRC (ref, ASTM E-18), and ground to the recommended diameter shown in the tables of dimensions. It may be through hardened, or it may be case hardened, with an effective case depth of 0.030 inch (0.8 mm) (Effective case depth is defined as the distance from the surface inward to the equivalent of 50 HRC hardness level after grinding.)

Taper within the length of the raceway should not exceed 0.0003 inch (0.008 mm), or one-half the diameter tolerance, whichever is smaller. The radial deviation from true circular form of the raceway should not exceed .0001 inch (0.0025 mm) for diameters up to and including 1 inch (25.4 mm). For raceways greater than 1.0 inch or 25mm the allowable radial deviation may be greater than .0001 inch (0.0025 mm) by a factor of raceway diameter (in inches) divided by 1.0 or a factor of raceway diameter (in mm) divided by 25.4. Surface finish on the raceway should not exceed 16 microinches a.a. (arithmetic average) or 0.4  $\mu$ m (on the R<sub>a</sub> scale). Deviations will reduce the load capacity and fatigue life of the shaft.



# DRAWN CUP ROLLER CLUTCHES

## INSTALLATION

Simplicity of installation promotes additional cost savings. The drawn cup roller clutch, or the clutch and bearing assembly, must be pressed into its housing. Procedures are virtually identical with those for installing drawn cup bearings as detailed on page 361. The unit is pressed into the bore of a gear hub or pulley hub, or housing of the proper size, and no shoulders, splines, keys, screws or snap rings are required.

Installation procedures are summarized in the following sketches:

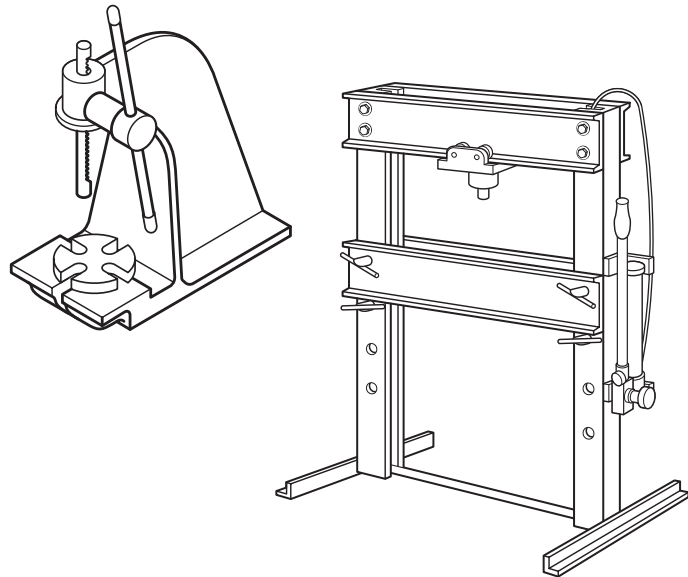

Use an arbor press or hydraulic ram press which will exert steady pressure. Never use a hammer or other tool requiring pounding to drive the clutch into its housing.

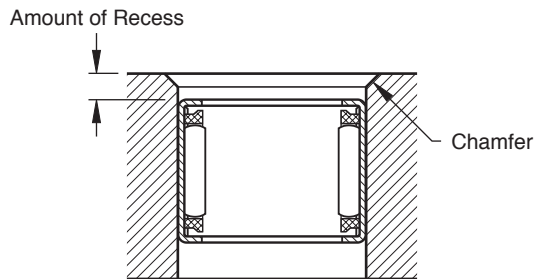

Make sure that the housing bore is chamfered to permit easy introduction of the clutch and bearing or the clutch unit. Press unit slightly beyond the chamfer in the housing bore to assure full seating. Through bored housings are always preferred. If the housing has a shoulder, never seat the clutch against the shoulder. For further details see page 361.



**IMPORTANT:** The mounted clutch or clutch and bearing assembly engages when the housing is rotated relative to the shaft in the direction of the arrow and LOCK marking (← LOCK) stamped on the cup. Make sure that the unit is oriented properly before pressing it into its housing.

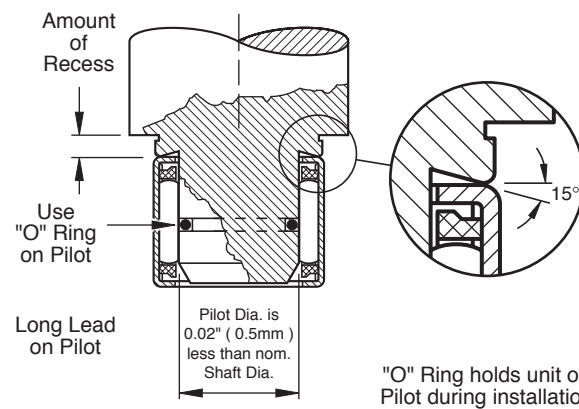

Use an installation tool as shown in the diagram above. If clutch is straddled by needle roller bearings, press units into position in proper sequence and preferably leave a small clearance between units.

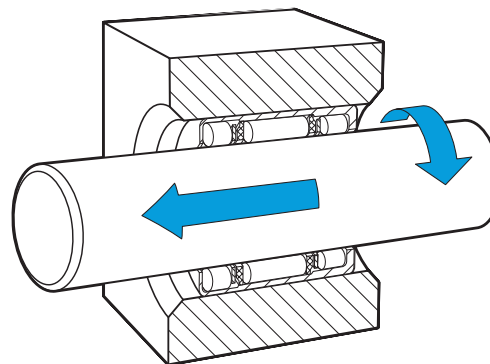

When assembling the shaft, it should be rotated during insertion. The end of the shaft should have a large chamfer or rounding.

# DRAWN CUP ROLLER CLUTCHES

## APPLIED LOADS

The clutch-only unit is designed to transmit purely torque loads. Applied torque should not exceed the catalog ratings which are based on the compressive strength of well-aligned clutch components. Bearings on either side of the clutch are required to assure concentricity between the shaft and the housing and to support radial loads during clutch overrun. Integral clutch and bearing assemblies are available for this purpose where the radial loads are light.

In determining the total torque load on a clutch, it is essential to consider the torque due to inertial forces developed in the mechanism, in addition to the externally applied torque. The larger the clutch and the greater the mass of the mechanism controlled by it, the more important this consideration becomes.

Clutch lockup depends upon static friction. For this reason applications involving severe vibrations or axial motion of the shaft within the clutch are to be avoided. Applications in which there are overhanging or overturning loads should incorporate bearings which will maintain alignment between the shaft and the clutch housing. Consult your Torrington Engineering Sales Office for recommendations.

## LUBRICATION

Oil is the preferred lubricant, as it minimizes wear and heat generation. For those applications where oil is not practical, clutches are packed with a soft grease containing mineral oil. Thick grease will retard roller engagement and can cause individual rollers to slip, possibly overload- ing any engaged rollers.

## TEMPERATURE

Temperature extremes can cause clutch malfunctions and failure. The molded acetal resin plastic cage with integral springs holds its necessary resiliency and strength when the operating temperature within the clutch is kept below 200°F (93°C). The clutch with reinforced nylon cage and separate steel springs operates well at temperatures up to 250°F (121°C) continuously and to 300°F (150°C) intermittently. Excessive thickening of the lubricant at low temperatures may prevent some or all of the rollers from engaging. New applications should be tested under expected operating conditions to determine whether or not temperature problems exist.

## BACKLASH

Backlash, or lost motion, prior to engagement is minimal. The variation in backlash from one cycle to another is extremely low. Grease lubrication or improper fitup (housing bore and shaft diameter) may increase backlash. Angular displacement between the shaft and housing increases as an applied torque load is increased.

## RATE OF ENGAGEMENT

Clutch lockup depends upon static friction. Axial motion between shaft and clutch rollers prevents lockup.

Clutches with integral springs engage satisfactorily at cyclic rates up to 200 engagements per minute. Intermittent operation at higher rates has been successful. The steel spring type clutches have proven dependability at rates up to 6000 or 7000 engagements per minute. Even higher cyclic rates may be practical. Since grease may impair engagement at high cyclic rates, a light oil should be used.

## OVERRUN LIMIT SPEED

Exact limiting speeds are not easily predictable. The value for each clutch given in the tabular data is not absolute but serves as a guide for the designer. Oil lubrication is absolutely necessary for high speed operations. Consultation with the Engineering Sales Office is recommended when overrunning speeds are high.

## INSPECTION

Although the outer cup of the clutch is accurately drawn from strip steel, it can go slightly out of round during heat treatment. When the assembly is pressed into a ring gauge or properly prepared housing of correct size and wall thickness, it becomes round and is properly sized. Direct measurement of the outside diameter of a drawn cup assembly is an incorrect inspection procedure. The proper inspection procedure is as follows:

1. Press the assembly into a ring gauge of the proper size as given in the tabular data.
2. Gauge the bore with the specified plug gauges of the proper size, as given in the tables of dimensions.
  - a. The **locking plug** is rotated to insure lockup when the clutch is operated on a low limit shaft and is mounted in a high limit housing strong enough to properly size the clutch.
  - b. The **overrun plug** is rotated to insure free overrunning when the clutch is operated on a high limit shaft and is mounted in a low limit housing.
  - c. The **go plug** and **no go plug** insure proper size of the bearings in the clutch and bearing assemblies.

Gauge sizes are listed in the tables of dimensions. Plug gauge sizes reflect adjustment for the loose and tight conditions resulting from high or low housings and shafts. Inch to metric and metric to inch conversions are listed for the convenience of the user, but the designer should understand that the controlling dimensions are in inches for nominal inch assemblies and millimeters for nominal metric assemblies.

# DRAWN CUP ROLLER CLUTCHES

## Type DC Roller Clutches

Before ordering any clutch check for availability.

Nominal dimensions with rounded conversions are shown below. Shaft raceway and housing bore diameters necessary for proper mounting and operation are listed on the opposite page.

Types FC, FCS, FCL-K and RC-FS clutches have stainless steel springs inserted in the, molded cage to position the rollers for instantaneous lockup.

Type RC clutches have springs integrally molded with the cage to position the rollers for instantaneous lockup.



The mounted clutch engages when the housing is rotated relative to the shaft in the direction of the arrow marking (←LOCK) stamped on the cup.

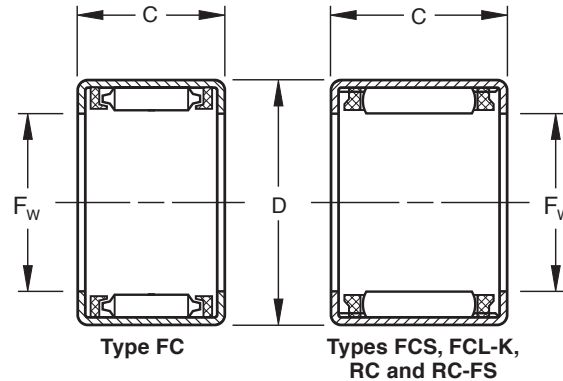

### DIMENSIONS AND RATINGS

F <sub>w</sub> Bore		D O.D.		C Width		Clutch Designation		Torque Rating †	Z Minimum O.D. of Steel Housing for Rated Torque		Overrun Limiting Speed
(nominal)		(nominal)		+0.000 -0.010	+0.00 -0.25	with Stainless Steel Springs	with Integral Springs		inch	mm	
inch	mm	inch	mm	inch	mm			lbf • in.			
1/8	3,18	3/32	7,14	0.250	6,35	—	RC-02	2.86	0.44	11	50000
0.16	<b>4</b>	0.31	8	0.236	6	FC-4-K	—	2.78	0.44	11	50000
0.24	<b>6</b>	0.39	10	0.472	12	FCS-6	—	18.60	0.55	14	39300
1/4	6,35	7/16	11,11	0.500	12,70	—	RC-040708	17.20	0.62	16	38000
0.31	<b>8</b>	0.47	12	0.472	12	FCL-8-K	—	28.70	0.67	17	28700
0.31	<b>8</b>	0.55	14	0.472	12	FC-8	—	35.80	0.79	20	30500
3/8	9,52	5/8	15,88	0.500	12,70	RC-061008-FS*	RC-061008	45.40	0.88	22	25300
0.39	<b>10</b>	0.55	14	0.472	12	FCL-10-K	—	39.10	0.77	20	22700
0.39	<b>10</b>	0.63	16	0.472	12	FC-10	—	50.40	0.98	25	23700
0.47	<b>12</b>	0.71	18	0.630	16	FC-12	—	118	1.10	27	19300
1/2	12,70	3/4	19,05	0.500	12,70	RC-081208-FS*	RC-081208	73.60	1.10	28	18700
3/8	15,88	7/8	22,22	0.625	15,88	RC-101410-FS*	RC-101410	143	1.20	30	14700
0.63	<b>16</b>	0.87	22	0.630	16	FC-16	—	182	1.20	31	14000
3/4	19,05	1	25,40	0.625	15,88	RC-121610-FS*	RC-121610	196	1.40	36	11300
0.79	<b>20</b>	1.02	26	0.630	16	FC-20	—	274	1.50	38	10700
0.98	<b>25</b>	1.26	32	0.787	20	FC-25	—	605	1.80	46	8670
<b>1</b>	25,40	1 3/16	33,34	0.625	15,88	RC-162110-FS*	RC-162110	412	1.90	48	8670
1.18	<b>30</b>	1.46	37	0.787	20	FC-30	—	845	2.0	51	7330

\* Suffix "-FS" is not always stamped on the clutch cup. Type RC-FS with stainless steel springs is always readily identified by RED clutch cage.

† Torque ratings are given in pound force inches: 1 lbf • in = 0.113 N • m = 0.0115 kgf • m

# DRAWN CUP ROLLER CLUTCHES

Proper inspection requires installation of the clutch in a ring gauge and then checking the bore with the appropriate plug gauges. Please read the section on "INSPECTION" on page 499.

Types FC, FCS and FCL-K clutch series are manufactured to metric dimensions. Inch dimensions shown are for the convenience of the designer. The controlling dimensions are in millimeters.

Types RC and RC-FS clutch series are manufactured to inch dimensions. Metric dimensions shown are for the convenience of the designer. The controlling dimensions are in inches.

When applying these clutches, it is important that separate bearings be used adjacent to the clutches to carry radial loads and assure concentricity between the shaft and the housing.

For full details on "INSTALLATION" see page 498.

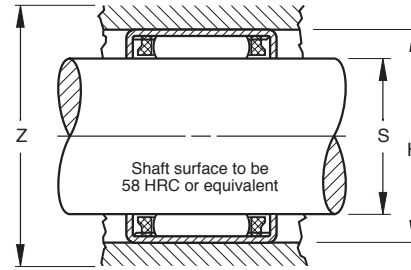

GAUGING						MOUNTING							
Ring gauge		Clutch Locking Plug		Clutch Overrun Plug		Inch Mounting				Metric Mounting			
						S		H		S		H	
						Shaft Raceway Diameter		Housing Bore		Shaft Raceway Diameter		Housing Bore	
inch	mm	inch	mm	inch	mm	inches		inches		millimeters		millimeters	
						max	min	min	max	max	min	min	max
0.28170	7,1552	0.12440	3,1598	0.12580	3,1953	0.1250	0.1247	0.2812	0.2817	3,175	3,167	7,142	7,155
0.31433	7,9840	0.15669	3,9800	0.15764	4,0040	0.1575	0.1572	0.3142	0.3148	4,000	3,992	7,981	7,996
0.39307	9,9840	0.23543	5,9800	0.23638	6,0040	0.2362	0.2359	0.3930	0.3935	6,000	5,992	9,981	9,996
0.43800	11,1252	0.24950	6,3373	0.25130	6,3830	0.2500	0.2495	0.4370	0.4380	6,350	6,337	11,100	11,125
0.47165	11,9800	0.31402	7,9760	0.31516	8,0050	0.3150	0.3146	0.4715	0.4722	8,000	7,991	11,977	11,995
0.55039	13,9800	0.31402	7,9760	0.31516	8,0050	0.3150	0.3146	0.5503	0.5510	8,000	7,991	13,977	13,995
0.62550	15,8877	0.37450	9,5123	0.37630	9,5580	0.3750	0.3745	0.6245	0.6255	9,525	9,512	15,862	15,887
0.55039	13,9800	0.39276	9,9760	0.39390	10,0050	0.3937	0.3933	0.5503	0.5510	10,000	9,991	13,977	13,995
0.62913	15,9800	0.39276	9,9760	0.39390	10,0050	0.3937	0.3933	0.6290	0.6297	10,000	9,991	15,977	15,995
0.70787	17,9800	0.47142	11,9740	0.47268	12,0060	0.4724	0.4720	0.7078	0.7085	12,000	11,989	17,977	17,995
0.75050	19,0627	0.49950	12,6873	0.50130	12,7330	0.5000	0.4995	0.7495	0.7505	12,700	12,687	19,037	19,062
0.87550	22,2377	0.62450	15,8623	0.62630	15,9080	0.6250	0.6245	0.8745	0.8755	15,875	15,862	22,212	22,237
0.86520	21,9760	0.62882	15,9720	0.63016	16,0060	0.6299	0.6295	0.8650	0.8659	16,000	15,989	21,972	21,993
0.99950	25,3873	0.74850	19,0119	0.75030	19,0576	0.7500	0.7495	0.9995	1.0005	19,050	19,037	25,387	25,412
1.02268	25,9760	0.78622	19,9700	0.78768	20,0070	0.7874	0.7869	1.0225	1.0233	20,000	19,987	25,972	25,992
1.25874	31,9720	0.98295	24,9670	0.98453	25,0070	0.9843	0.9838	1.2585	1.2595	25,000	24,987	31,967	31,992
1.31200	33,3248	0.99850	25,3619	1.00030	25,4076	1.0000	0.9995	1.3120	1.3130	25,400	25,387	33,325	33,350
1.45559	36,9720	1.17980	29,9670	1.18138	30,0070	1.1811	1.1806	1.4554	1.4564	30,000	29,987	36,967	36,992

# DRAWN CUP ROLLER CLUTCHES

## Type DC Roller Clutch and Bearing Assemblies

Nominal dimensions with rounded conversions are shown below. Shaft raceway and housing bore diameters necessary for proper mounting and operation are listed on the opposite page.

Types FCB, FCBL-K and RCB-FS clutch and bearing assemblies have stainless steel springs inserted in the molded cage to position the rollers for instantaneous lockup.

Type RCB clutch and bearing assemblies have springs integrally molded with the cage to position the rollers for instantaneous lockup.

Before ordering any clutch and bearing assemblies check for availability.



The mounted clutch and bearing assemblies engages when the housing is rotated relative to the shaft in the direction of the arrow marking (←LOCK) stamped on the cup.

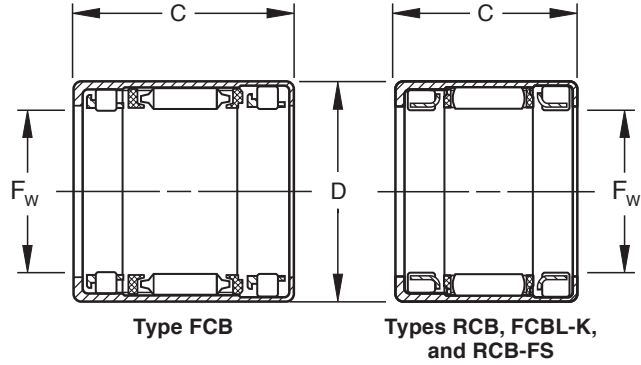

### DIMENSIONS AND RATINGS

F <sub>w</sub> Bore		D O.D.		C Width		Clutch and Bearing Assembly Designation		Torque Rating †	Z Minimum O.D. of Steel Housing for Rated Torque		Bearing Basic Dynamic Load Rating § Cr ISO 281 (max)		Bearing Working Load	Overrun Limiting Speed
(nominal)		(nominal)		0.000 -0.010	+0.00 -0.25	with Stainless Steel Springs	with Integral Springs		inch	mm	lbf	lbf		
inch	mm	inch	mm	inch	mm			lbf • in.	inch	mm	lbf	lbf	lbf	rpm
0.31	8	0.47	12	0.866	22	FCBL-8K	—	29	0.67	17	523	717	344	28 700
0.31	8	0.55	14	0.787	20	FCB-8	—	35.8	0.79	20	541	742	322	30 500
3/8	9.52	5/8	15.88	0.875	22.22	RCB-061014-FS*	RCB-061014	45.4	0.88	22	848	1 160	566	25 300
0.39	10	0.63	16	0.787	20	FCB-10	—	50.4	0.98	25	628	861	388	23 700
0.47	12	0.71	18	1.024	26	FCB-12	—	118	1.1	28	882	1 210	634	19 300
1/2	12.70	3/4	19.05	0.875	22.22	RCB-081214-FS*	RCB-081214	73.6	1.1	28	1 020	1 400	720	18 700
5/8	15.88	7/8	22.22	1.000	25.40	RCB-101416-FS*	RCB-101416	143	1.2	30	1 140	1 560	914	14 700
0.63	16	0.87	22	1.024	26	FCB-16	—	182	1.2	30	951	1 300	742	14 000
3/4	19.05	1	25.40	1.000	25.40	RCB-121616-FS*	RCB-121616	196	1.4	36	1 270	1 740	1 030	11 300
0.79	20	1.02	26	1.024	26	FCB-20	—	274	1.5	38	1 180	1 610	974	10 700
0.98	25	1.26	32	1.181	30	FCB-25	—	605	1.8	46	1 580	2 170	1 350	8 670
1	25.40	1 1/16	33.34	1.063	27	RCB-162117-FS*	RCB-162117	412	1.9	48	2 240	3 060	1 890	8 670
1.18	30	1.46	37	1.181	30	FCB-30	—	845	2.0	51	1 620	2 210	1 510	7 330

\* Suffix "-FS" is not always stamped on the clutch cup. Type RC-FS with stainless steel springs is always readily identified by RED clutch cage.

† Torque ratings are given in pound force inches: 1 lbf • in = 0.113 N • m = 0.0115 kgf • m

§ Bearing load ratings are given in pounds-force: 1 lbf = 0.454 kgf = 4.448N. For single roller path use one-half the listed rating.

Required Basic Dynamic Load Rating (C<sub>r</sub>) = Applied Load • SF • LF

Ⓣ Symbol denotes Basic Dynamic Load Rating to be used in load-life calculations taking into consideration the application guidelines and limitations given in this catalog.

Applications involving loads approaching this rating or the tabulated working load, whichever is the smaller, should be referred to your Engineering Sales Office before a final selection is made.

Load Ratings are based on a minimum raceway hardness of 58 HRC or equivalent.

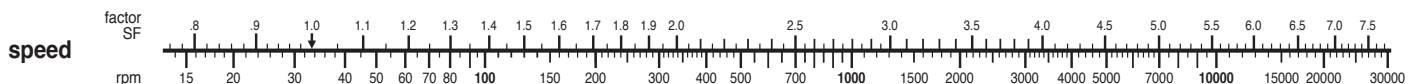

# DRAWN CUP ROLLER CLUTCHES

Proper inspection requires installation of the clutch and bearing assembly in a ring gauge and then checking the bore with the appropriate plug gauges. Please read the section on "INSPECTION" on page 499.

Types FCB and FCBL-K clutch and bearing assemblies are manufactured to metric dimensions. Inch dimensions shown are for the convenience of the designer. The controlling dimensions are in millimeters.

Types RCB and RCB-FS clutch and bearing assemblies are manufactured to inch dimensions. Metric dimensions shown are for the convenience of the designer. The controlling dimensions are in inches.

For full details on "INSTALLATION" see page 498.

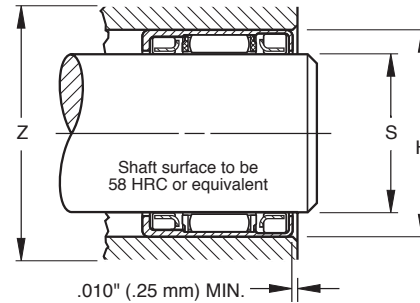

GAUGING								MOUNTING							
Ring gauge		Clutch Locking Plug		Clutch Overrun and Bearing Go Plug		Bearing No Go Plug		Inch Mounting				Metric Mounting			
								S Shaft Raceway Diameter		H Housing Bore		S Shaft Raceway Diameter		H Housing Bore	
								inches		inches		millimeters		millimeters	
inch	mm	inch	mm	inch	mm	inch	mm	max	min	min	max	max	min	min	max
0.47165	11,9800	0.31402	7,9760	0.31516	8,0050	0.31626	8,0330	0.3150	0.3146	0.4715	0.4722	8,000	7,991	11,977	11,995
0.55039	13,9800	0.31402	7,9760	0.31516	8,0050	0.31626	8,0330	0.3150	0.3146	0.5503	0.5510	8,000	7,991	13,977	13,995
0.6255	15,8877	0.37450	9,5123	0.37610	9,5529	0.37750	9,5885	0.3750	0.3745	0.6245	0.6255	9,525	9,512	15,862	15,888
0.62913	15,9800	0.39276	9,9760	0.39390	10,0050	0.39500	10,0330	0.3937	0.3933	0.6290	0.6297	10,000	9,991	15,977	15,995
0.70787	17,9800	0.47142	11,9740	0.47268	12,0060	0.47386	12,0360	0.4724	0.4720	0.7078	0.7085	12,000	11,989	17,977	17,995
0.7505	19,0627	0.49950	12,6873	0.50110	12,7279	0.50250	12,7635	0.5000	0.4995	0.7495	0.7505	12,700	12,687	19,037	19,062
0.8755	22,2377	0.62450	15,8623	0.62610	15,9089	0.62750	15,9385	0.6250	0.6245	0.8745	0.8755	15,875	15,862	22,212	22,237
0.8652	21,9760	0.62882	15,9720	0.63016	16,0060	0.63134	16,0360	0.6299	0.6295	0.8650	0.8659	16,000	15,989	21,972	21,993
0.9995	25,3873	0.74850	19,0119	0.75010	19,0525	0.75150	19,0881	0.7500	0.7495	0.9995	1.0005	19,050	19,037	25,387	25,412
1.02268	25,9760	0.78622	19,9700	0.78768	20,0070	0.78909	20,0430	0.7874	0.7869	1.0225	1.0233	20,000	19,987	25,972	25,992
1.25874	31,9720	0.98295	24,9670	0.98453	25,0070	0.98594	25,0430	0.9843	0.9838	1.2585	1.2595	25,000	24,987	31,967	31,992
1.312	33,3248	0.99850	25,3619	1.00010	25,4025	1.00150	25,4381	1.0000	0.9995	1.3120	1.3130	25,400	25,387	33,325	33,350
1.45559	36,9720	1.17980	29,9670	1.18138	30,0070	1.18280	30,0430	1.1811	1.1806	1.4554	1.4564	30,000	29,987	36,967	36,992

