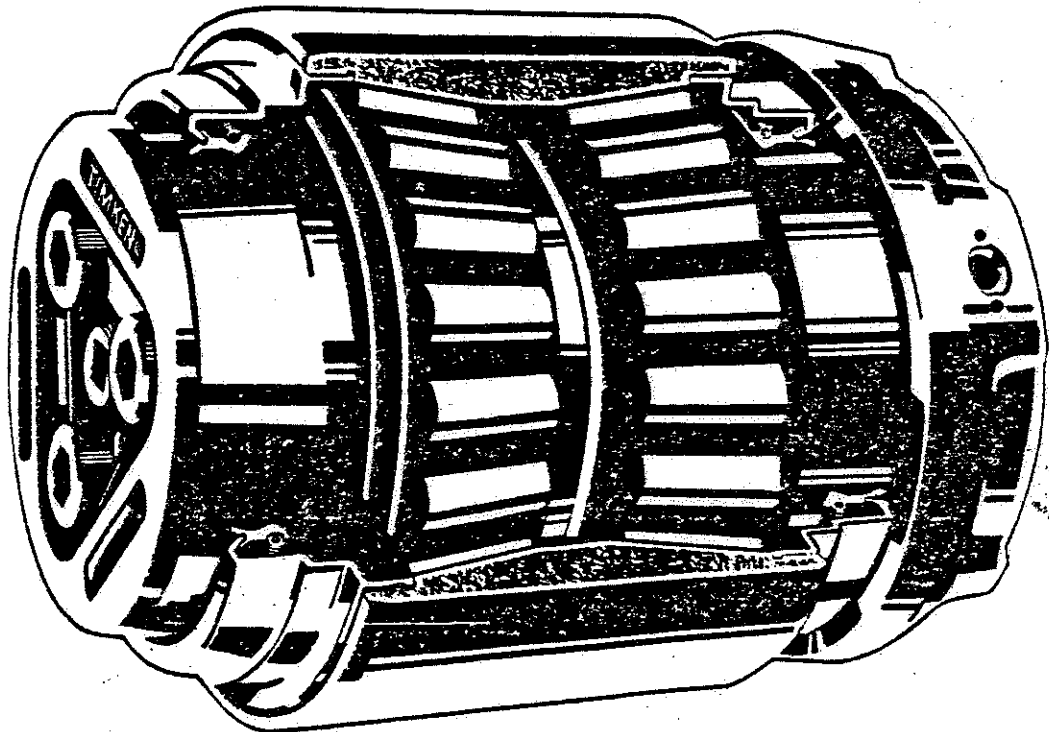

TIMKEN

REGISTERED TRADEMARK
TAPERED ROLLER BEARINGS

**"AP" BEARINGS
FOR INDUSTRIAL APPLICATIONS**

SUPPLEMENT

**ASSEMBLY NUMBERS
AND
NON-STANDARD BEARINGS**



C

C

C

"AP"™ BEARINGS FOR INDUSTRIAL APPLICATIONS SUPPLEMENT

CONTENTS

	PAGE
Nomenclature; Typical "AP" Bearing Mounting Arrangements	1
"AP" Bearing Ordering Procedure	3
OVERALL ASSEMBLY NUMBERS	
Standard "AP" Bearings With: Backing Ring With Flinger (Except G(7 x 12), GG(7); Axle End Cap: Recessed End Cap; Backing Spacer	
Class B	4
Class C	6
Class D	8
Class E	10
Class F	12
Class G(7 x 12)	14
Class G(7 x 14)	15
Class GG(7)	17
Class K	19
Standard "AP" Bearings With: Backing Ring Without Flinger; NFL** End Cap	
Class B through G(7 x 12)	20
Breakdown of NFL** End Cap Assemblies and Backing Ring Without Flinger	
	22
NON-STANDARD "AP" BEARINGS	
Reduced Width Assemblies	23
Special Cone Bore Sizes: Class B(3¾); D(5); EE(6); G(6¾); G(6½); GG(6½)	24
Breakdown of Axle End Cap Assemblies and Backing Ring Assemblies	
	26
Standard Parts for Timken "AP" Bearings	27

TM - Trademark of The Timken Company

**NO FIELD LUBRICATION

NOMENCLATURE

NFL*
END CAP
ASSEMBLY

RECESSED
END CAP
ASSEMBLY

AXLE
END CAP
ASSEMBLY

BEARING
ASSEMBLY

BACKING RING
ASSEMBLY

BACKING SPA

WITH
FLINGER

WITHOUT
FLINGER

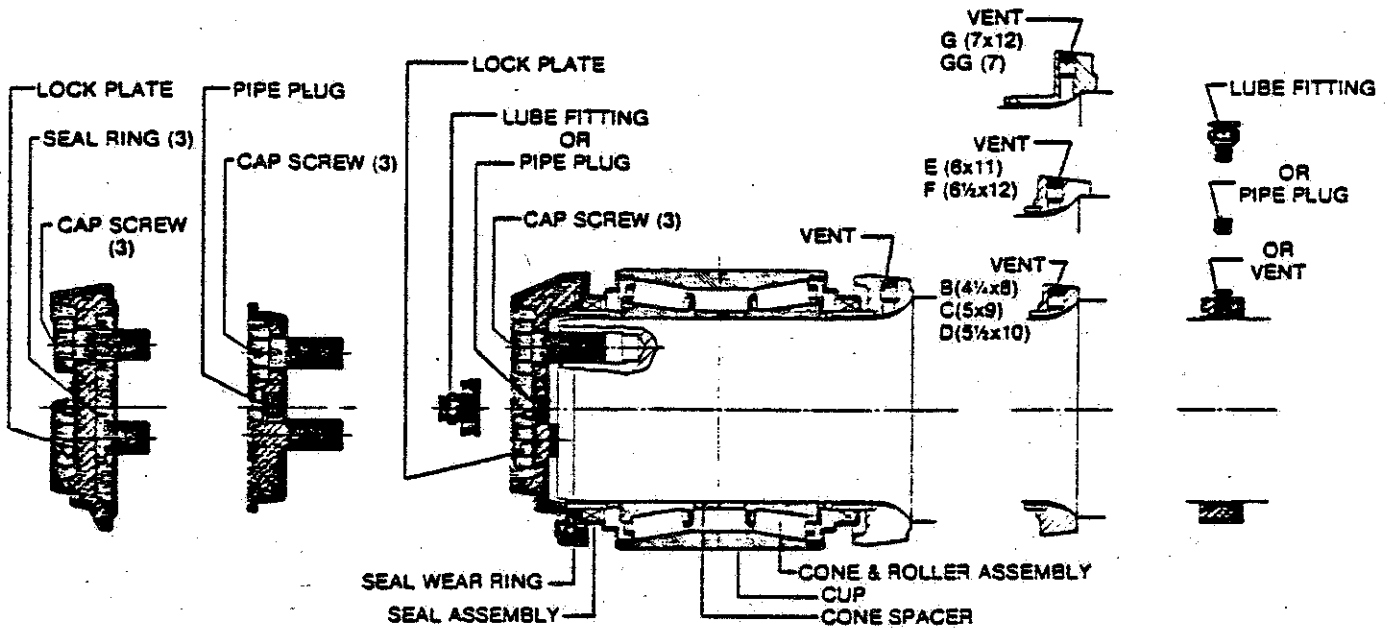

* No Field Lubrication

TYPICAL "AP" BEARING MOUNTING ARRANGEMENTS

The following illustrations show typical combinations of basic "AP" bearings, and auxiliary parts (shaded).

When making up a mounting arrangement, a provision for relubrication should be made on one side of the bearing, with a vent at the opposite side. If an auxiliary part is not used, these provisions should be made in the parts adjacent the bearing.

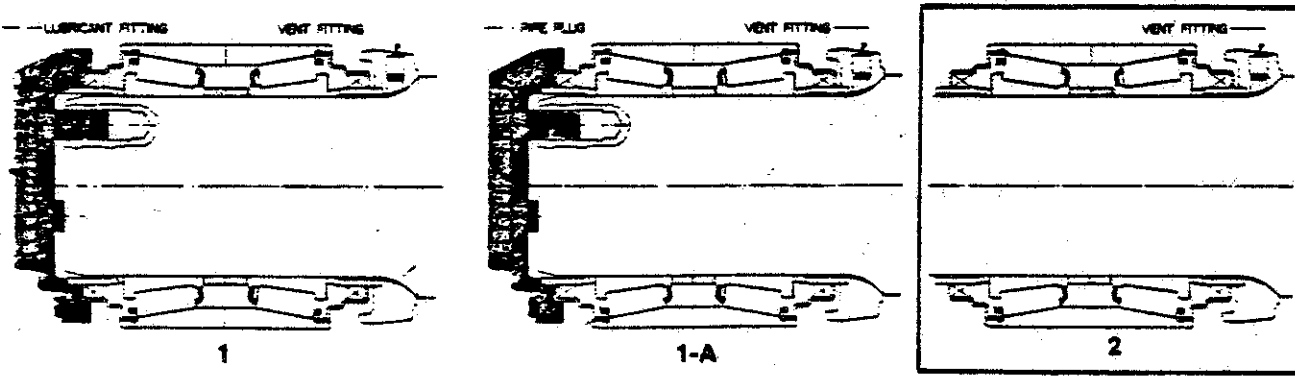

NOTE: Shaded items are ordered separately from basic bearing (2 or 4).

TYPICAL "AP" BEARING MOUNTING ARRANGEMENTS

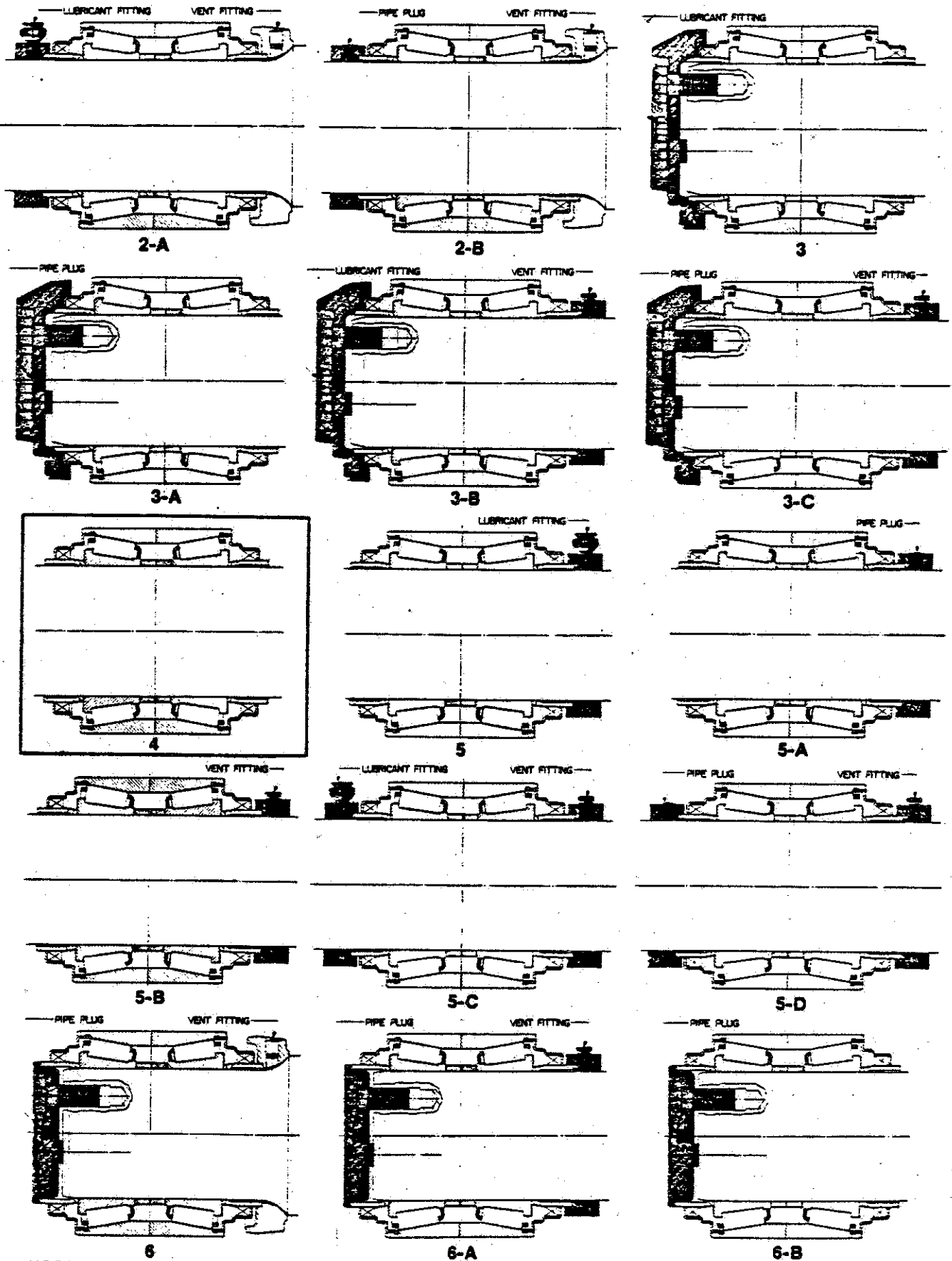

NOTE: Shaded items are ordered separately from basic bearing (2 or 4).



"AP" BEARING ORDERING PROCEDURE

When ordering "AP" Bearings specify the following information:

1. Quantity of Assemblies
2. Bearing Class
3. Cone Number
4. Assembly Number

NOTE:

If no overall assembly number is listed for bearing and auxiliary parts needed, then specify the overall assembly number of the cone and mounting arrangement (2 or 4) desired along with the list of auxiliary parts needed.

EXAMPLE

To order 8 class F "AP" bearings with an overall assembly number of 90107:

8 - Class F (6½ x 12) "AP" Bearings
Cone Number - HM133444
Overall Bearing Number - 90107

"AP" BEARING ASSEMBLIES
CLASS-B (4¼ x 8)
HM120848

To form an overall bearing assembly, combine the basic "AP" bearing (the number 4 bearing mounting arrangement shown below) with the appropriate auxiliary part(s).

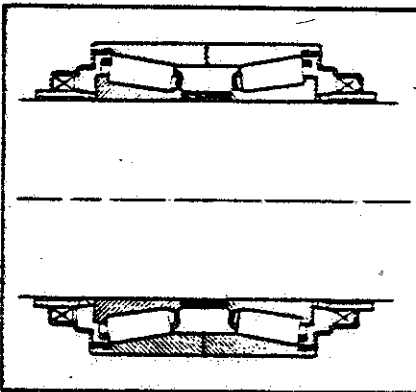

OVERALL ASSEMBLIES			AUXILIARY PARTS			
STANDARD	CODE	BRG. MOUNTING ARRANGEMENT	QTY.	AUXILIARY PART	PART NO.	ASSEMBLY NO.
90C14	90078	4				
90C23	--	1*	(1)	Axle end cap	K86877	90012
			(1)	Backing ring	K86874	90010
90C11	9005C	1-A*	(1)	Axle end cap	K86877	90010
			(1)	Backing ring	K86874	90010
90C12	9006C	2	(1)	Backing ring	K86874	90
90C80	--	2-A*	(1)	Backing spacer	K118891	
			(1)	Lube fitting	K78880	
			(1)	Backing ring	K86874	90010
90C86	--	2-B*	(1)	Backing spacer	K118891	
			(1)	Pipe plug	K46462	
			(1)	Backing ring	K86874	90010
90C91	90C97	3*	(1)	Axle end cap	K86877	90012
90C121	90C99	3-A*	(1)	Axle end cap	K86877	90010
90115	--	3-B*	(1)	Axle end cap	K86877	90012
			(1)	Backing spacer	K118891	
			(1)	Vent fitting	K83093	
90C83	90161	3-C*	(1)	Axle end cap	K86877	90010
			(1)	Backing spacer	K118891	
			(1)	Vent fitting	K83093	
90C74	--	5*	(1)	Backing spacer	K118891	
			(1)	Lube fitting	K78880	
90C88	--	5-A*	(2)	Backing spacer	K118891	
			(1)	Pipe plug	K46462	
90C82	90160	5-B*	(1)	Backing spacer	K118891	
			(1)	Vent fitting	K83093	
90106	90138	5-C*	(2)	Backing spacer	K118891	
			(1)	Lube fitting	K78880	
			(1)	Vent fitting	K83093	
90C84	90C98	5-D*	(2)	Backing spacer	K118891	
			(1)	Pipe plug	K46462	
			(1)	Vent fitting	K83093	
90C65	90105	6*	(1)	Recessed end cap	K399069	90010
			(1)	Backing ring	K86874	90010
90C81	--	6-A*	(1)	Recessed end cap	K399069	90010
			(1)	Backing spacer	K118891	
			(1)	Vent fitting	K83093	
90C37	90C77	6-B*	(1)	Recessed end cap	K399069	90010

*See Pages 1 and 2 for Bearing Mounting Arrangements

- NOTE: (1) The standard cup O.D. is ground to a tolerance of +.005 -.000 and can be used in any application which does not require a press fit for the cup.
- (2) The code 350 cup O.D. is ground to a tolerance of +.003 +.004 and is used in applications that require a press fit for the cup. This assembly can be used in any application.

**"AP" BEARING ASSEMBLIES
CLASS-B (4 1/4 x 8)
HM120848**

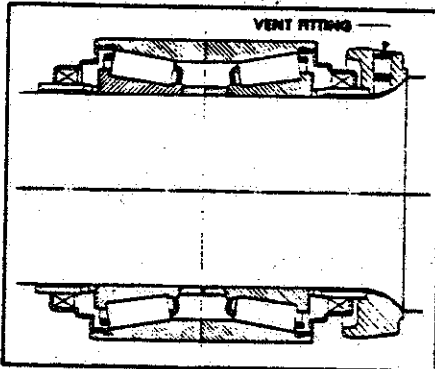

OVERALL ASSEMBLIES			AUXILIARY PARTS		
STANDARD	CODE	BRG. MOUNTING ARRANGEMENT	QTY. AUXILIARY PART	PART NO.	ASSEMBLY NO.
	90060	2			
90012	90060	2			
90023	--	1*	(1) Axle end cap	K86877	90012
90011	90059	1-A*	(1) Axle end cap	K86877	90010
90080	--	2-A*	(1) Backing spacer	K118891	
			(1) Lube fitting	K78880	
90086	--	2-B*	(1) Backing spacer	K118891	
			(1) Pipe plug	K46462	
90065	90105	6*	(1) Recessed end cap	K399069	90010

To form an overall bearing assembly, combine the number 2 bearing mounting arrangement with the appropriate auxiliary parts(s)

Note: A number 2 bearing mounting arrangement is shipped with the backing ring pressed on the seal wear ring.



Backing Ring

K86874 90010 consists of
(1) K86874 - Backing ring
(1) K89716 - Vent fitting



Axle End Cap

K86877 90010 consists of:
(1) K86877 - End cap
(3) K53399 - Cap screws 3/4"
(1) K84326 - Lock plate
(1) K86891 - Pipe plug 3/8"

K86877 90012 consists of:
(1) K86877 - End cap
(3) K53399 - Cap screws 3/4"
(1) K84326 - Lock plate
(1) K399065 - Lube fitting 3/8"



Recessed End Cap

K399069 90010 consists of:
(1) K399069 - End cap
(3) K344077 - Cap screws 5/8" socket head
(1) K75801 - Pipe plug 1/2"



Backing Spacer

K118891 with one of the following:
K83093 - Vent fitting 1/4"
K46462 - Pipe plug 1/4"
K78880 - Grease fitting 1/4"

HM124646
K86003

Asy 1 Tim HM124646
Asy 1 Tim K86003

10050
90056
↑

"AP" BEARING ASSEMBLIES
CLASS-C (5 x 9)
HM124646

has nothing
but wear Rings

To form an overall bearing assembly, combine the basic "AP" bearing (the number 4 bearing mounting arrangement shown below) with the appropriate auxiliary part(s).

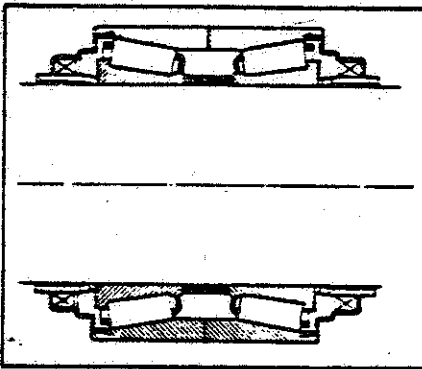

OVERALL ASSEMBLIES			AUXILIARY PARTS		
CODE	BRG. MOUNTING ARRANGEMENT	QTY.	AUXILIARY PART	PART NO.	ASSEMBLY NO.
STANDARD	350				
90056	90068	4			
90047	--	1*	(1) Axle end cap	K86003	90015
			(1) Backing ring	K85588	90010
90013	--	1-A*	(1) Axle end cap	K86003	90010
			(1) Backing ring	K85588	90010
90014	90180	2	(1) Backing ring	K85588	90
90086	90098	2-A*	(1) Backing spacer	K120198	
			(1) Lube fitting	K78880	
			(1) Backing ring	K85588	90010
90078	--	2-B*	(1) Backing spacer	K120198	
			(1) Pipe plug	K46462	
			(1) Backing ring	K85580	90010
90085	--	3*	(1) Axle end cap	K86003	90015
90083	--	3-A*	(1) Axle end cap	K86003	90010
90089	90185	3-B*	(1) Axle end cap	K86003	90015
			(1) Backing spacer	K120198	
			(1) Vent fitting	K83093	
--	--	3-C*	(1) Axle end cap	K86003	90010
			(1) Backing spacer	K120198	
			(1) Vent fitting	K83093	
90108	--	5*	(1) Backing spacer	K120198	
			(1) Lube fitting	K78880	
90084	--	5-A*	(1) Backing spacer	K120198	
			(1) Pipe plug	K46462	
90092	90184	5-B*	(1) Backing spacer	K120198	
			(1) Vent fitting	K83093	
90090	--	5-C*	(2) Backing spacer	K120198	
			(1) Lube fitting	K78880	
			(1) Vent fitting	K83093	
--	--	5-D*	(2) Backing spacer	K120198	
			(1) Pipe plug	K46462	
			(1) Vent fitting	K83093	
90065	--	6*	(1) Recessed end cap	K399070	90010
			(1) Backing ring	K85588	90010
--	--	6-A*	(1) Recessed end cap	K399070	
			(1) Backing spacer	K120198	
			(1) Vent fitting	K83093	
90057	90069	6-B*	(1) Recessed end cap	K399070	90010

*See Pages 1 and 2 for Bearing Mounting Arrangements

- NOTE: (1) The standard cup O.D. is ground to a tolerance of +.005 -.000 and can be used in any application which does not require a press fit for the cup.
- (2) The code 350 cup O.D. is ground to a tolerance of +.003 +.004 and is used in applications that require a press fit for the cup. This assembly can be used in any application.

**"AP" BEARING ASSEMBLIES
CLASS-C (5 x 9)
HM124646**

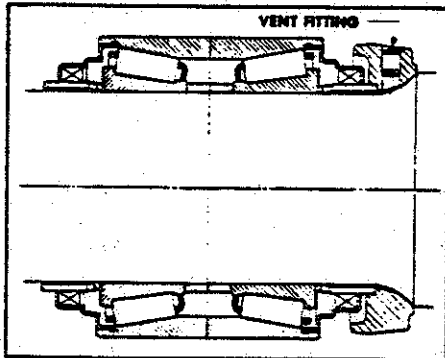

To form an overall bearing assembly, combine the number 2 bearing mounting arrangement with the appropriate auxiliary parts(s)

OVERALL ASSEMBLIES			AUXILIARY PARTS		
STANDARD	CODE	BRG. MOUNTING ARRANGEMENT	QTY. AUXILIARY PART	PART NO.	ASSEMBLY NO.
	350				
90014	90180	2			
90047	--	1*	(1) Axle end cap	K86003	90015
90013	--	1-A*	(1) Axle end cap	K86003	90010
90086	90098	2-A*	(1) Backing spacer (1) Lube fitting	K120198 K78880	
90078	--	2-B*	(1) Backing spacer (1) Pipe plug	K120198 K46462	
90065	--	6*	(1) Recessed end cap	K399070	90010

Note: A number 2 bearing mounting arrangement is shipped with the backing ring pressed on the seal wear ring.



Backing Ring

K85588 90010 consists of
(1) K85588 - Backing ring
(1) K89716 - Vent fitting



Recessed End Cap

K399070 90010 consists of:
(1) K399070 - End cap
(3) K344077 - Cap screws 5/8" socket head
(1) K75801 - Pipe plug 1/2"



Axle End Cap

K86003 90010 consists of:
(1) K86003 - End cap
(3) K44434 - Cap screws 7/8"
(1) K84325 - Lock plate
(1) K86891 - Pipe plug 3/8"

K86003 90015 consists of:
(1) K86003 - End cap
(3) K44434 - Cap screws 7/8"
(1) K84325 - Lock plate
(1) K399065 - Lube fitting 3/8"



Backing Spacer

K120198 with one of the following:
K83093 - Vent fitting 1/4"
K46462 - Pipe plug 1/4"
K78880 - Grease fitting 1/4"

"AP" BEARING ASSEMBLIES
CLASS - D (5½ x 10)
HM127446

To form an overall bearing assembly, combine the basic "AP" bearing (the number 4 bearing mounting arrangement shown below) with the appropriate auxiliary part(s).

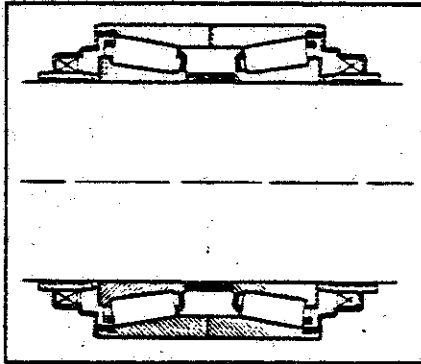

OVERALL ASSEMBLIES			AUXILIARY PARTS		
CODE		BEG. MOUNTING ARRANGEMENT	QTY. AUXILIARY PART	PART NO.	ASSEMBLY NO.
STANDARD	350				
90048	90106	4			
90011	90211	1*	(1) Axle end cap (1) Backing ring	K85521 K85525	90011 90010
90013	--	1-A*	(1) Axle end cap (1) Backing ring	K85521 K85525	90010 90
90012	90098	2	(1) Backing ring	K85525	90010
90120	--	2-A*	(1) Backing spacer (1) Lube fitting (1) Backing ring	K120178 K78880 K85525	90010
90118	--	2-B*	(1) Backing spacer (1) Pipe plug (1) Backing ring	K120178 K46462 K85525	90010
90093	--	3*	(1) Axle end cap	K85521	90011
--	90107	3-A*	(1) Axle end cap	K85521	90010
90167	90189	3-B*	(1) Axle end cap (1) Backing spacer (1) Vent fitting	K85521 K120178 K83093	90011
--	--	3-C*	(1) Axle end cap (1) Backing spacer (1) Vent fitting	K85521 K120178 K83093	90010
90168	--	5*	(1) Backing spacer (1) Lube fitting	K120178 K78880	
90114	--	5-A*	(1) Backing spacer (1) Pipe plug	K120178 K46462	
90138	90188	5-B*	(1) Backing spacer (1) Vent fitting	K120178 K83093	
90170	--	5-C*	(2) Backing spacer (1) Lube fitting (1) Vent fitting	K120178 K78880 K83093	
90166	--	5-D*	(2) Backing spacer (1) Pipe plug (1) Vent fitting	K120178 K46462 K83093	
90101	90099	6*	(1) Recessed end cap (1) Backing ring	K399071 K85525	90010 90010
90157	--	6-A*	(1) Recessed end cap (1) Backing spacer (1) Vent fitting	K399071 K120178 K83093	90010
90083	90181	6-B*	(1) Recessed end cap	K399071	90010

*See Pages 1 and 2 for Bearing Mounting Arrangements.

- NOTE: (1) The standard cup O.D. is ground to a tolerance of +.005 -.000 and can be used in any application which does not require a press fit for the cup.
- (2) The code 350 cup O.D. is ground to a tolerance of +.003 +.004 and is used in applications that require a press fit for the cup. This assembly can be used in any application.

**"AP" BEARING ASSEMBLIES
CLASS-D (5½ x 10)
HM127446**

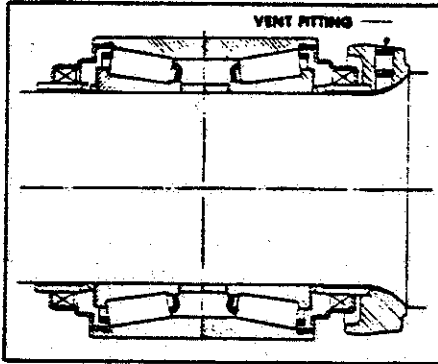

OVERALL ASSEMBLIES			AUXILIARY PARTS			
CODE	STANDARD	BRG. MOUNTING ARRANGEMENT	QTY.	AUXILIARY PART	PART NO.	ASSEMBLY NO.
90012	90098	2				
90011	90211	1*	(1)	Axle end cap	K85521	90011
90013	--	1-A*	(1)	Axle end cap	K85521	90010
90120	--	2-A*	(1)	Backing spacer	K120178	
			(1)	Lube fitting	K78880	
90118	--	2-B*	(1)	Backing spacer	K120178	
			(1)	Pipe plug	K46462	
90101	90099	6*	(1)	Recessed end cap	K399071	90010

To form an overall bearing assembly, combine the number 2 bearing mounting arrangement with the appropriate auxiliary parts(s).

Note: A number 2 bearing mounting arrangement is shipped with the backing ring pressed on the seal wear ring.



Backing Ring

K85525 90010 consists of:
(1) K85525 - Backing ring
(1) K89716 - Vent fitting



Recessed End Cap

K399071 90010 consists of:
(1) K399071 - End cap
(3) K33003 - Cap screws 7/8"
(1) K75801 - Pipe plug 1/2"



Axle End Cap

K85521 90010 consists of:
(1) K85521 - End cap
(3) K44434 - Cap screws 7/8"
(1) K80511 - Lock plate
(1) K75801 - Pipe plug 1/2"

K85521 90011 consists of:
(1) K85521 - End cap
(3) K44434 - Cap screws 7/8"
(1) K80511 - Lock plate
(1) K49022 - Lube fitting 1/2"



Backing Spacer

K120178 with one of the following:
K83093 - Vent fitting 1/4"
K46462 - Pipe plug 1/4"
K78880 - Grease fitting 1/4"

**"AP" BEARING ASSEMBLIES
CLASS-E (6 x 11)
HM129848**

To form an overall bearing assembly, combine the basic "AP" bearing (the number 4 bearing mounting arrangement shown below) with the appropriate auxiliary part(s).

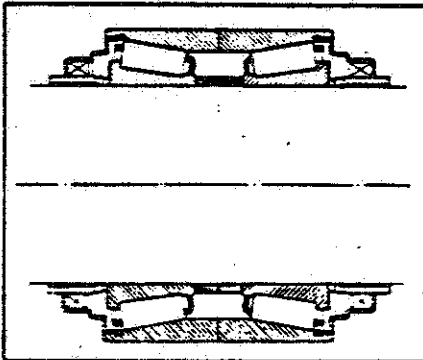

OVERALL ASSEMBLIES			AUXILIARY PARTS			
CODE		SER. MOUNTING ARRANGEMENT	QTY.	AUXILIARY PART	PART NO.	ASSEMBLY NO.
STANDARD	350					
90054	90104	4				
90011	90125	1"	(1)	Axle end cap	K85510	90011
			(1)	Backing ring	K85095	90010
90013	--	1-A"	(1)	Axle end cap	K85510	90010
			(1)	Backing ring	K85095	90010
90012	90114	2	(1)	Backing ring	K85095	901
90142	90212	2-A"	(1)	Backing spacer	K120190	
			(1)	Lube fitting	K78880	
			(1)	Backing ring	K85095	90010
90126	--	2-B"	(1)	Backing spacer	K120190	
			(1)	Pipe plug	K46462	
			(1)	Backing ring	K85095	90010
90169	90105	3"	(1)	Axle end cap	K85510	90011
--	--	3-A"	(1)	Axle end cap	K85510	90010
90155	--	3-B"	(1)	Axle end cap	K85510	90011
			(1)	Backing spacer	K120190	
			(1)	Vent fitting	K83093	
--	--	3-C"	(1)	Axle end cap	K85510	90010
			(1)	Backing spacer	K120190	
			(1)	Vent fitting	K83093	
90154	--	5"	(1)	Backing spacer	K120190	
			(1)	Lube fitting	K78880	
90120	--	5-A"	(1)	Backing spacer	K120190	
			(1)	Pipe plug	K46462	
90156	--	5-B"	(1)	Backing spacer	K120190	
			(1)	Vent fitting	K83093	
90248	--	5-C"	(2)	Backing spacer	K120190	
			(1)	Lube fitting	K78880	
			(1)	Vent fitting	K83093	
90122	--	5-D"	(2)	Backing spacer	K120190	
			(1)	Pipe plug	K46462	
			(1)	Vent fitting	K83093	
90109	90199	6"	(1)	Recessed end cap	K399072	90010
			(1)	Backing ring	K85095	90010
90171	--	6-A"	(1)	Recessed end cap	K399072	90010
			(1)	Backing spacer	K120190	
			(1)	Vent fitting	K83093	
90101	--	6-B"	(1)	Recessed end cap	K399072	90010

*See Pages 1 and 2 for Bearing Mounting Arrangements

- NOTE: (1) The standard cup O.D. is ground to a tolerance of $+0.005 -0.000$ and can be used in any application which does not require a press fit for the cup.
- (2) The code 350 cup O.D. is ground to a tolerance of $+0.003 +0.004$ and is used applications that require a press fit for the cup. This assembly can be used in any application.

**"AP" BEARING ASSEMBLIES
CLASS-E (6 x 11)
HM129848**

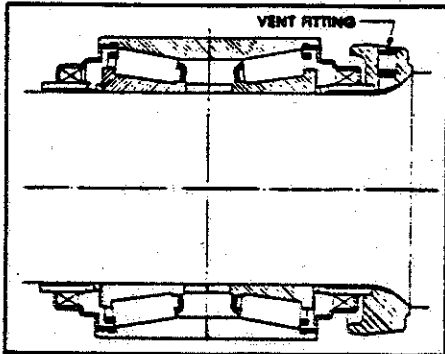

OVERALL ASSEMBLIES			AUXILIARY PARTS		
CODE		BRG. MOUNTING ARRANGEMENT	QTY. AUXILIARY PART	PART NO.	ASSEMBLY NO.
STANDARD	350				
90012	90114	2			
90011	90125	1*	(1) Axle end cap	K85510	90011
90013	--	1-A*	(1) Axle end cap	K85510	90010
90142	90212	2-A*	(1) Backing spacer (1) Lube fitting	K120190 K78880	
90126	--	2-B*	(1) Backing spacer (1) Pipe plug	K120190 K46462	
90109	90199	5*	(1) Recessed end cap	K399072	90010

To form an overall bearing assembly, combine the number 2 bearing mounting arrangement with the appropriate auxiliary parts(s)

Note: A number 2 bearing mounting arrangement is shipped with the backing ring pressed on the seal wear ring.

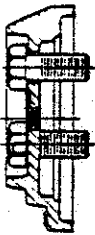

Axle End Cap

K85510 90010 consists of:
 (1) K85510 - End cap
 (3) K84354 - Cap screws 1"
 (1) K80596 - Lock plate
 (1) K75801 - Pipe plug 1/2"

K85510 90011 consists of:
 (1) K85510 - End cap
 (3) K84354 - Cap screws 1"
 (1) K80596 - Lock plate
 (1) K49022 - Lube fitting 1/2"



Backing Ring

K85095 90010 consists of
 (1) K85095 - Backing ring
 (1) K89716 - Vent fitting



Recessed End Cap

K399072 90010 consists of:
 (1) K399072 - End cap
 (3) K74600 - Cap screws 1"
 (1) K75801 - Pipe plug 1/2"



Backing Spacer

K120190 with one of the following:
 K83093 - Vent fitting 1/4"
 K46462 - Pipe plug 1/4"
 K78880 - Grease fitting 1/4"

"AP" BEARING ASSEMBLIES
CLASS-F (6½ x 12)
HM133444

To form an overall bearing assembly, combine the basic "AP" bearing (the number 4 bearing mounting arrangement shown below) with the appropriate auxiliary part(s).

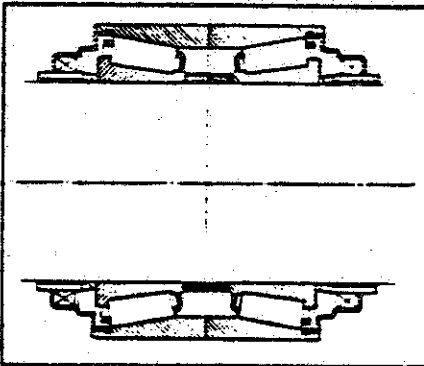

OVERALL ASSEMBLIES			AUXILIARY PARTS		
CODE		BRG. MOUNTING ARRANGEMENT	QTY. AUXILIARY PART	PART NO.	ASSEMBLY NO.
STANDARD	350				
90076	90128	4			
90015	90211	1*	(1) Axle end cap	K85517	90012
			(1) Backing ring	K85516	90010
90011	--	1-A*	(1) Axle end cap	K85517	90010
			(1) Backing ring	K85516	90010
90012	90212	2	(1) Backing ring	K85516	90010
90124	--	2-A*	(1) Backing spacer	K120160	
			(1) Lube fitting	K78880	
			(1) Backing ring	K85516	90010
90122	--	2-B*	(1) Backing spacer	K120160	
			(1) Pipe plug	K46462	
			(1) Backing ring	K85516	90010
90107	90175	3*	(1) Axle end cap	K85517	90012
--	90141	3-A*	(1) Axle end cap	K85517	90010
90221	--	3-3*	(1) Axle end cap	K85517	90012
			(1) Backing spacer	K120160	
			(1) Vent fitting	K83093	
--	--	3-C*	(1) Axle end cap	K85517	90010
			(1) Backing spacer	K120160	
			(1) Vent fitting	K83093	
90184	--	3*	(1) Backing spacer	K120160	
			(1) Lube fitting	K78880	
90126	--	3-A*	(1) Backing spacer	K120160	
			(1) Pipe plug	K46462	
90220	--	3-B*	(1) Backing spacer	K120160	
			(1) Vent fitting	K83093	
--	90236	3-C*	(2) Backing spacer	K120160	
			(1) Lube fitting	K78880	
			(1) Vent fitting	K83093	
90270	--	3-D*	(2) Backing spacer	K120160	
			(1) Pipe plug	K46462	
			(1) Vent fitting	K83093	
90117	--	6*	(1) Recessed end cap	K399073	90010
			(1) Backing ring	K85516	90010
--	--	6-A*	(1) Recessed end cap	K399073	90010
			(1) Backing spacer	K120160	
			(1) Vent fitting	K83093	
90087	90169	6-B*	(1) Recessed end cap	K399073	90010

*See Pages 1 and 2 for Bearing Mounting Arrangements

- NOTE:**
- (1) The standard cup O.D. is ground to a tolerance of +.005 -.000 and can be used in any application which does not require a press fit for the cup.
 - (2) The code 350 cup O.D. is ground to a tolerance of +.003 +.004 and is used in applications that require a press fit for the cup. This assembly can be used in any application.

"AP" BEARING ASSEMBLIES
CLASS-F (6½ x 12)
HM133444

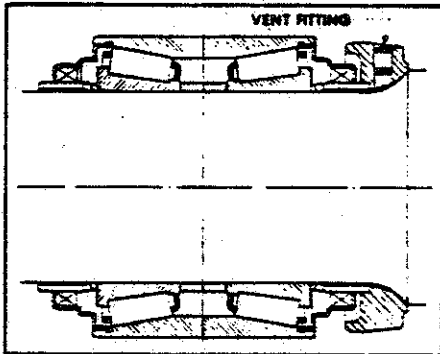

OVERALL ASSEMBLIES			AUXILIARY PARTS			
STANDARD	CODE	SRG. MOUNTING ARRANGEMENT	QTY.	AUXILIARY PART	PART NO.	ASSEMBLY NO.
	90012	90212	2			
	90015	90211	1*	(1) Axle end cap	K85517	90012
	90011	--	1-A*	(1) Axle end cap	K85517	90010
	90124	--	2-A*	(1) Backing spacer	K120160	
				(1) Lube fitting	K78880	
	90122	--	2-B*	(1) Backing spacer	K120160	
				(1) Pipe plug	K46462	
	90117	--	6*	(1) Recessed end cap	K399073	90010

To form an overall bearing assembly, combine the number 2 bearing mounting arrangement with the appropriate auxiliary parts(s)

Note: A number 2 bearing mounting arrangement is shipped with the backing ring pressed on the seal wear ring.



Backing Ring

K85516 90010 consists of
 (1) K85516 - Backing ring
 (1) K89716 - Vent fitting



Axle End Cap

K85517 90010 consists of:
 (1) K85517 - End cap
 (3) K84351 - Cap screws 1-1/8"
 (1) K84324 - Lock plate
 (1) K75801 - Pipe plug 1/2"

K85517 90012 consists of:
 (1) K85517 - End cap
 (3) K84351 - Cap screws 1-1/8"
 (1) K84324 - Lock plate
 (1) K49022 - Lube fitting 1/2"



Recessed End Cap

K399073 90010 consists of:
 (1) K399073 - End cap
 (3) K74600 - Cap screws 1"
 (1) K75801 - Pipe plug 1/2"



Backing Spacer

K120160 with one of the following:
 K83093 - Vent fitting 1/4"
 K46462 - Pipe plug 1/4"
 K78880 - Grease fitting 1/4"

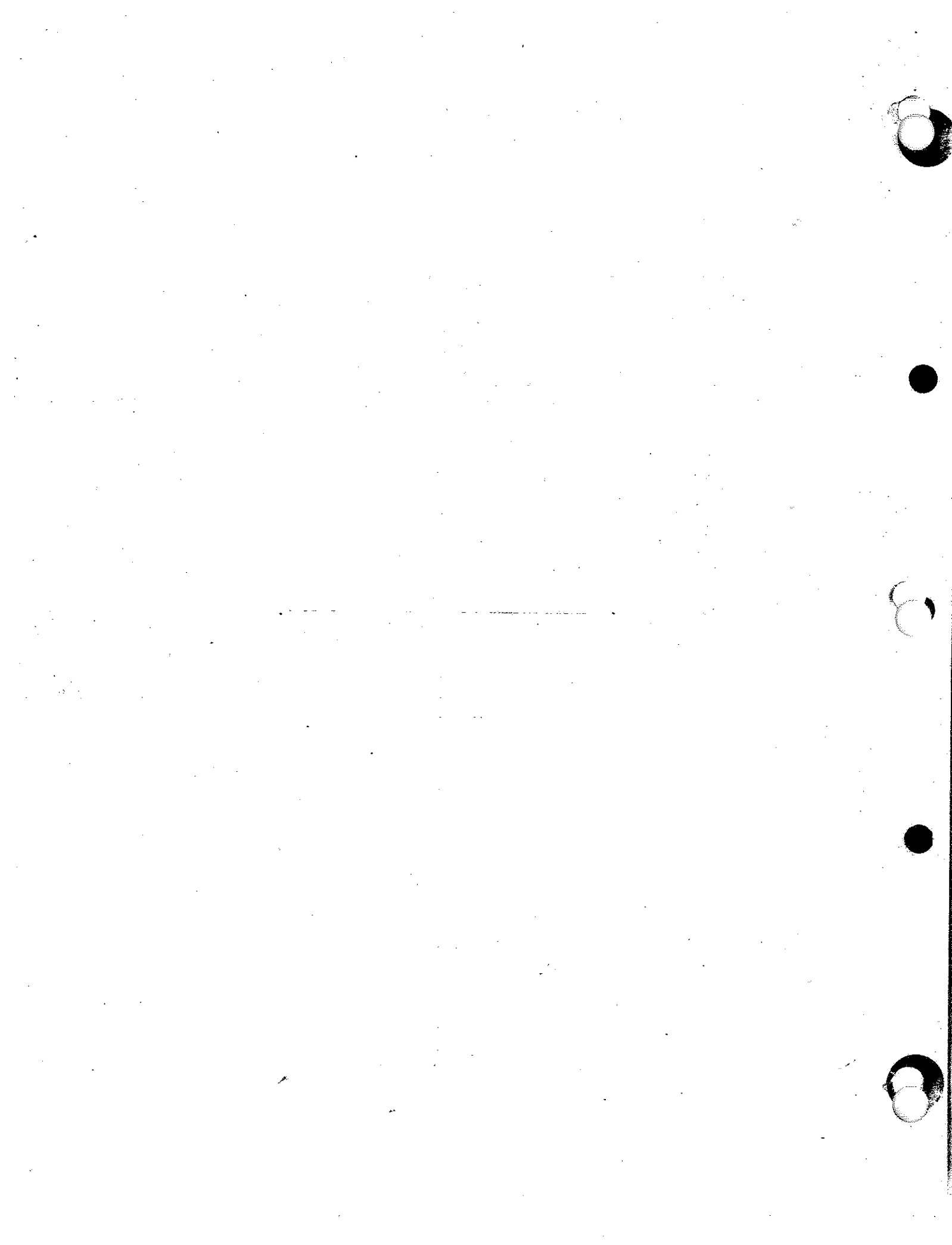

**"AP" BEARING ASSEMBLIES
CLASS-G (7 x 12)
HM136948**

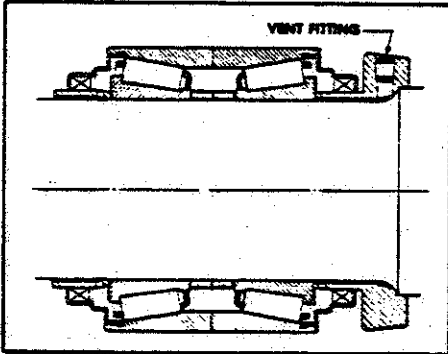

To form an overall bearing assembly, combine the number 2 bearing mounting arrangement with the appropriate auxiliary parts(s)

OVERALL ASSEMBLIES			AUXILIARY PARTS		
STANDARD	CODE	Brg. MOUNTING ARRANGEMENT	QTY. AUXILIARY PART	PART NO.	ASSEMBLY NO.
	350				
90048	90104	2			
90049	90105	1*	(1) Axle end cap	K95199	90011
90051	--	1-A*	(1) Axle end cap	K95199	90010
90124	90184	2-A*	(1) Backing spacer (1) Lube fitting	K118866 K78880	
90146	--	2-B*	(1) Backing spacer (1) Pipe plug	K118866 K46462	
90089	--	6*	(1) Recessed end cap	K399074	90010

*See Pages 1 and 2 for Bearing Mounting Arrangements



Axle End Cap

K95199 90010 consists of:
 (1) K95199 - End cap
 (3) K84398 - Cap screws 1-1/4"
 (1) K84701 - Lock plate
 (1) K75801 - Pipe plug 1/2"

K95199 90011 consists of:
 (1) K95199 - End cap
 (3) K84398 - Cap screws 1-1/4"
 (1) K84701 - Lock plate
 (1) K49022 - Lube fitting 1/2"



Recessed End Cap

K399074 90010 consists of:
 (1) K399074 - End cap
 (3) K74588 - Cap screws 1-1/8"
 (1) K75801 - Pipe plug 1/2"



Backing Spacer

K118866 with one of the following:
 K46462 - Pipe plug 1/4"
 K78880 - Grease fitting 1/4"

**"AP" BEARING ASSEMBLIES
CLASS-G (7 x 14)
HM136948**

To form an overall bearing assembly, combine the basic "AP" bearing (the number 4 bearing mounting arrangement shown below) with the appropriate auxiliary part(s).

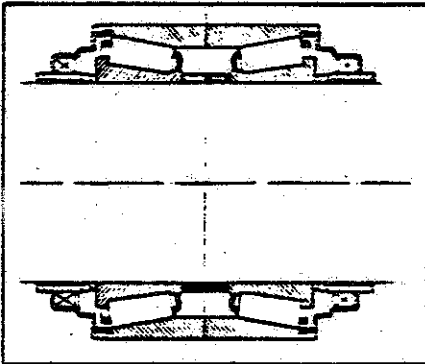

OVERALL ASSEMBLIES			AUXILIARY PARTS		
CODE		BEG. MOUNTING ARRANGEMENT	QTY. AUXILIARY PART	PART NO.	ASSEMBLY NO.
STANDARD	350				
90082	90098	4			
90093	--	1*	(1) Axle end cap (1) Backing ring	K412057 K95200	90011 90010
90085	--	1-A*	(1) Axle end cap (1) Backing ring	K412057 K95200	90010 90010
90012	90096	2	(1) Backing ring	K95200	90010
90170	--	2-A*	(1) Backing spacer (1) Lube fitting (1) Backing ring	K118866 K78880 K95200	90010
90108	--	2-B*	(1) Backing spacer (1) Pipe plug (1) Backing ring	K118866 K46462 K95200	90010
90137	--	3*	(1) Axle end cap	K412057	90011
--	90107	3-A*	(1) Axle end cap	K412057	90010
90149	--	3-B*	(1) Axle end cap (1) Backing spacer (1) Vent fitting	K412057 K118866 K83093	90011
--	--	3-C*	(1) Axle end cap (1) Backing spacer (1) Vent fitting	K412057 K118866 K83093	90010
90138	--	5*	(1) Backing spacer (1) Lube fitting	K118866 K78880	
90080	--	5-A*	(1) Backing spacer (1) Pipe plug	K118866 K46462	
90150	--	5-B*	(1) Backing spacer (1) Pipe plug	K118866 K83093	
--	--	5-C*	(2) Backing spacer (1) Lube fitting (1) Vent fitting	K118866 K78880 K83093	
--	--	5-D*	(2) Backing spacer (1) Pipe plug (1) Vent fitting	K118866 K46462 K83093	
90109	90095	6*	(1) Recessed end cap (1) Backing ring	K399074 K95200	90010 90010
90171	--	6-A*	(1) Recessed end cap (1) Backing spacer (1) Vent fitting	K399074 K118866 K83093	90010
90083	--	6-B*	(1) Recessed end cap	K399074	90010

*See Pages 1 and 2 for Bearing Mounting Arrangements

- NOTE: (1) The standard cup O.D. is ground to a tolerance of $+.005 - .000$ and can be used in any application which does not require a press fit for the cup.
- (2) The code 350 cup O.D. is ground to a tolerance of $+.003 + .004$ and is used in applications that require a press fit for the cup. This assembly can be used in any application.

**"AP" BEARING ASSEMBLIES
CLASS-G (7 x 14)
HM136948**

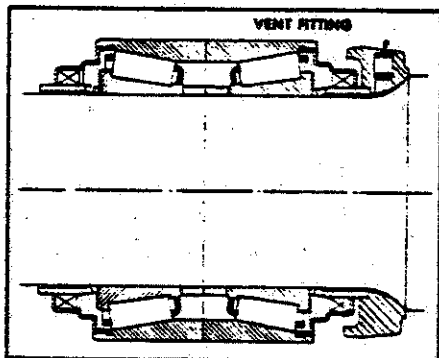

OVERALL ASSEMBLIES			AUXILIARY PARTS		
CODE		BRG. MOUNTING ARRANGEMENT	QTY. AUXILIARY PART	PART NO.	ASSEMBLY NO.
STANDARD	350				
90012	90096	2			
90093	--	1*	(1) Axle end cap	K412057	90011
90085	--	1-A*	(1) Axle end cap	K412057	90010
90170	--	2-A*	(1) Backing spacer (1) Lube fitting	K118866 K78880	
90108	--	2-B*	(1) Backing spacer (1) Pipe plug	K118866 K46462	
90109	90095	6*	(1) Recessed end cap	K399074	90010

To form an overall bearing assembly, combine the number 2 bearing mounting arrangement with the appropriate auxiliary parts(s)

Note: A number 2 bearing mounting arrangement is shipped with the backing ring pressed on the seal wear ring.



Backing Ring

K95200 90010 consists of
(1) K95200 - Backing ring
(1) K89716 - Vent fitting



Recessed End Cap

K399074 90010 consists of:
(1) K399074 - End cap
(3) K74588 - Cap screws 1-1/8"
(1) K75801 - Pipe plug 1/2"



Axle End Cap

K412057 90010 consists of:
(1) K412057 - End cap
(3) K84398 - Cap screws 1-1/4"
(1) K84701 - Lock plate
(1) K75801 - Pipe plug 1/2"

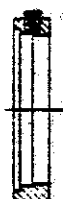

Backing Spacer

K412057 90011 consists of:
(1) K412057 - End cap
(3) K84398 - Cap screws 1-1/4"
(1) K84701 - Lock plate
(1) K49022 - Lube fitting 1/2"

K118866 with one of the following:
K83093 - Vent fitting 1/4"
K46462 - Pipe plug 1/4"
K78880 - Grease fitting 1/4"

**"AP" BEARING ASSEMBLIES
CLASS-GG (7)
H337846**

To form an overall bearing assembly, combine the basic "AP" bearing (the number 4 bearing mounting arrangement shown below) with the appropriate auxiliary part(s).

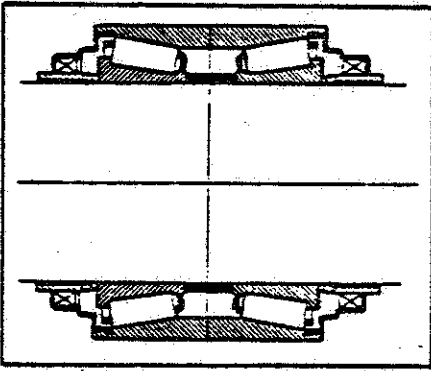

OVERALL ASSEMBLIES			AUXILIARY PARTS			
CODE		ERG. MOUNTING ARRANGEMENT	QTY.	AUXILIARY PART	PART NO.	ASSEMBLY NO.
STANDARD	350					
90120	90116	4				
		1*	(1)	Axle end cap	K462064**	
			(1)	Backing ring	K83160	90010
		1-A*	(1)	Axle end cap	K462064**	
			(1)	Backing ring	K83160	90010
90076	90112	2	(1)	Backing ring	K83160	90010
		2-A*	(1)	Backing spacer	K118866	
			(1)	Lube fitting	K78880	
			(1)	Backing ring	K83160	90010
		2-B*	(1)	Backing spacer	K118866	
			(1)	Pipe plug	K46462	
			(1)	Backing ring	K83160	90010
		3*	(1)	Axle end cap	K462064**	
		3-A*	(1)	Axle end cap	K462064**	
		3-B*	(1)	Axle end cap	K462064**	
			(1)	Backing spacer	K118866	
			(1)	Vent fitting	K83093	
		3-C*	(1)	Axle end cap	K462064**	
			(1)	Backing spacer	K118866	
			(1)	Vent fitting	K83093	
		5*	(1)	Backing spacer	K118866	
			(1)	Lube fitting	K78880	
		5-A*	(1)	Backing spacer	K118866	
			(1)	Pipe plug	K46462	
		5-B*	(1)	Backing spacer	K118866	
			(1)	Vent fitting	K83093	
		5-C*	(2)	Backing spacer	K118866	
			(1)	Lube fitting	K78880	
			(1)	Vent fitting	K83093	
		5-D*	(2)	Backing spacer	K118866	
			(1)	Pipe plug	K46462	
			(1)	Vent fitting	K83093	
		6*	(1)	Recessed end cap	K399074	90010
			(1)	Backing ring	K83160	90010
		6-A*	(1)	Recessed end cap	K399074	90010
			(1)	Backing spacer	K118866	
			(1)	Vent fitting	K83093	
90119	--	6-B*	(1)	Recessed end cap	K399074	90010

**K462064 not currently available. class G (7 x 12) axle end cap K95199 may be substituted.

*See Pages 1 and 2 for Bearing Mounting Arrangements

- NOTE: (1) The standard cup O.D. is ground to a tolerance of $+.003$ $+.005$ and can be used in any application which does not require a press fit for the cup.
- (2) The code 350 cup O.D. is ground to a tolerance of $+.003$ $+.004$ and is used in applications that require a press fit for the cup. This assembly can be used in any application.

**"AP" BEARING ASSEMBLIES
CLASS-GG (7)
H337846**

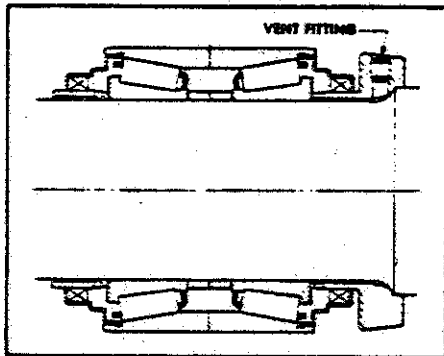

OVERALL ASSEMBLIES			AUXILIARY PARTS		
CODE		BRG. MOUNTING ARRANGEMENT	QTY. AUXILIARY PART	PART NO.	ASSEMBLY NO.
STANDARD	350				
90076	90112	2			
		1*	(1) Axle end cap	K462064**	
		1-A*	(1) Axle end cap	K462064**	
		2-A*	(1) Backing spacer	K118866	
			(1) Lube fitting	K78880	
		2-B*	(1) Backing spacer	K118866	
			(1) Pipe plug	K46462	
		6*	(1) Recessed end cap	K399074	

To form an overall bearing assembly, combine the number 2 bearing mounting arrangement with the appropriate auxiliary parts(s)

**K462064 Not currently available.

Class G (7 x 12) Axle End Cap K95199 may be substituted.

Axle End Cap G(7 x 12)



K95199 90010 consists of:
 (1) K95199 - End cap
 (3) K84398 - Cap screws 1-1/4"
 (1) K84701 - Lock plate
 (1) K75801 - Pipe plug 1/2"

K95199 90011 Consists of:
 (1) K95199 - End cap
 (3) K84398 - Cap screws 1-1/4"
 (1) K84701 - Lock plate
 (1) K49022 - Lube fitting 1/2"

Axle End Cap GG(7)

**K462064 90010 consists of:
 (1) K462064 - End cap
 (3) K462063 - Cap screws 1-1/4"H.S.
 (1) K84701 - Lock plate
 (1) K49022 - Lube fitting 1/2"

**K462064 consists of:
 (1) K462064 - End cap
 (3) K462063 - Cap screws 1-1/4"H.S.
 (1) K84701 - Lock plate
 (1) K75801 - Pipe plug 1/2"



Backing Ring

K83160 90010 consists of:
 (1) K83160 - Backing ring
 (1) K89716 - Vent fitting



Recessed End Cap

K399074 90010 consists of:
 (1) K399074 - End cap
 (3) K74588 - Cap screws 1-1/8"
 (1) K75801 - Pipe plug 1/2"



Backing Spacer

K118866 with one of the following:
 K83093 - Vent fitting 1/4"
 K46462 - Pipe plug 1/4"
 K78880 - Grease fitting 1/4"

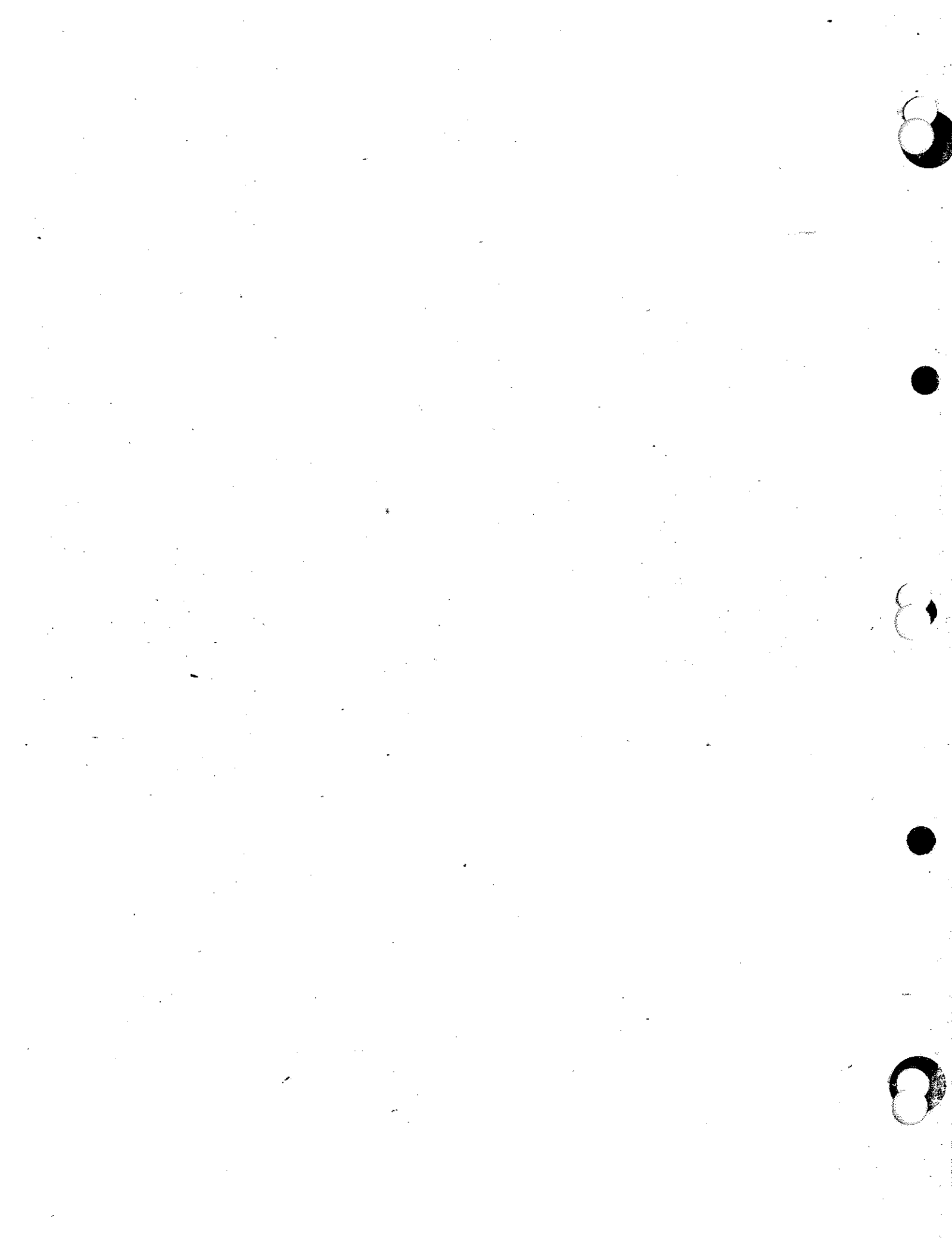

**"AP" BEARING ASSEMBLIES
CLASS-K (8)
M241547**

To form an overall bearing assembly, combine the basic "AP" bearing (the number 4 bearing mounting arrangement shown below) with the appropriate auxiliary part(s).

OVERALL ASSEMBLIES			AUXILIARY PARTS		
STANDARD	CODE	BRG. MOUNTING ARRANGEMENT	QTY. AUXILIARY PART	PART NO.	ASSEMBLY NO.
	350	4			
90028	90050	4			
90029	--	6-B*	(1) Recessed end cap	K504075	90010

*See Pages 1 and 2 for Bearing Mounting Arrangements

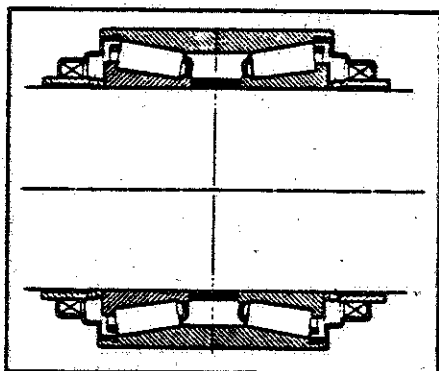

Recessed End Cap

K504075 90010 consists of:
 (1) K504075 - End cap
 (3) K74588 - Cap screws 1-1/8"
 (1) K75801 - Pipe plug 1/2"

- NOTE:** (1) The standard cup O.D. is ground to a tolerance of $+0.005 - .000$ and can be used in any application which does not require a press fit for the cup.
- (2) The code 350 cup O.D. is ground to a tolerance of $+0.003 +0.004$ and is used in applications that require a press fit for the cup. This assembly can be used in any application.

OVERALL ASSEMBLIES - STANDARD "AP" BEARINGS

CLASSES - B THROUGH G(7 x 12)
ASSEMBLIES USING NFL** END CAP; BACKING RING WITHOUT FLINGER

CLASS B (4-1/4 x 8)
HML20848-817XD-848XA

OVERALL ASSEMBLIES		BRG. MOUNTING ARRANGEMENT	AUXILIARY PARTS			
CODE	350		QTY.	AUXILIARY PART	PART NO.	ASSEMBLY NO.
90014	90078	4*				
90127	--	1-A*	(1)	NFL** End Cap	K523660	90010
			(1)	Backing Ring	K127203	90010
90124	--	2*	(1)	Backing Ring	K127203	90010
--	--	3-A*	(1)	NFL**End Cap	K523660	90010

CLASS C (5 x 9)
HML24646-618XD-646XA

OVERALL ASSEMBLIES		BRG. MOUNTING ARRANGEMENT	AUXILIARY PARTS			
CODE	350		QTY.	AUXILIARY PART	PART NO.	ASSEMBLY NO.
90056	90068	4*				
90151	--	1-A	(1)	NFL** End Cap	K523742	90010
			(1)	Backing Ring	K127204	90010
90148	--	2*	(1)	Backing Ring	K127204	90010
--	--	3-A*	(1)	NFL** End Cap	K523742	90010

CLASS D (5-1/2 x 10)
HML27446-415XD-446XA

OVERALL ASSEMBLIES		BRG. MOUNTING ARRANGEMENT	AUXILIARY PARTS			
CODE	350		QTY.	AUXILIARY PART	PART NO.	ASSEMBLY NO.
90048	90106	4*				
90205	--	1-A*	(1)	NFL** End Cap	K523744	90010
			(1)	Backing Ring	K127205	90010
90202	--	2*	(1)	Backing Ring	K127205	90010
--	--	3-A*	(1)	NFL**End Cap	K523744	90010

*See Pages 1 and 2 for Bearing Mounting Arrangements

**No field lubrication

OVERALL ASSEMBLIES - STANDARD "AP" BEARINGS

CLASSES - B THROUGH G(7 x 12)
ASSEMBLIES USING NFL** END CAP; BACKING RING WITHOUT FLINGER

CLASS E (6 x 11)
HM129848-814XD-848XA

OVERALL ASSEMBLIES			AUXILIARY PARTS		
CODE		BRG. MOUNTING ARRANGEMENT	QTY. AUXILIARY PART	PART NO.	ASSEMBLY NO.
STANDARD	350				
90054	90104	4*			
90203	--	1-A*	(1) NFL** End Cap	K523746	90010
			(1) Backing Ring	K127206	90010
90200	--	2*	(1) Backing Ring	K127206	90010
--	--	3-A*	(1) NFL** End Cap	K523746	90010

CLASS F (6-1/2 x 12)
HM133444-416XD-444XA

OVERALL ASSEMBLIES			AUXILIARY PARTS		
CODE		BRG. MOUNTING ARRANGEMENT	QTY. AUXILIARY PART	PART NO.	ASSEMBLY NO.
STANDARD	350				
90076	90128	4*			
90227	--	1-A*	(1) NFL** End Cap	K523748	90010
			(1) Backing Ring	K125685	90010
90206	--	2*	(1) Backing Ring	K125685	90010
--	--	3-A*	(1) NFL** End Cap	K523748	90010

CLASS G (7 x 12)
HM136948-916XD-948XA

OVERALL ASSEMBLIES			AUXILIARY PARTS		
CODE		BRG. MOUNTING ARRANGEMENT	QTY. AUXILIARY PART	PART NO.	ASSEMBLY NO.
STANDARD	350				
90179	--	1-A*	(1) NFL** End Cap	K523750	90010
			(1) Backing Ring	K83160	90010
90048	90104	2*	(1) Backing Ring	K83160	90010

*See Pages 1 and 2 for Bearing Mounting Arrangements

** No Field Lubrication



BREAKDOWN OF NFL** END CAP ASSEMBLIES AND BACKING RING WITHOUT FLINGER ASSEMBLIES

	NFL**END CAP	BACKING RING WITHOUT FLINGER
B(4 1/4 x 8)	<u>K523660 90010</u> Consists of: (1) K523660 End Cap (3) K53399 Cap Screws 3/4" (3) K523654 Seal Rings (1) K84326 Lock Plate	<u>K127203 90010</u> Consists of: (1) K127203 Backing Ring (1) K89716 Vent Fitting
C(5 x 9)	<u>K523742 90010</u> Consists of: (1) K523742 End Cap (3) K44434 Cap Screws 7/8" (3) K523655 Seal Rings (1) K84325 Lock Plate	<u>K127204 90010</u> Consists of: (1) K127204 Backing Ring (1) K89716 Vent Fitting
D(5 1/2 x 10)	<u>K523744 90010</u> Consists of: (1) K523744 End Cap (3) K44434 Cap Screws 7/8" (3) K523655 Seal Rings (1) K80511 Lock Plate	<u>K127205 90010</u> Consists of: (1) K127205 Backing Ring (1) K89716 Vent Fitting
E(6 x 11)	<u>K523746 90010</u> Consists of: (1) K523746 End Cap (3) K84354 Cap Screws 1" (3) K523656 Seal Rings (1) K80596 Lock Plate	<u>K127206 90010</u> Consists of: (1) K127206 Backing Ring (1) K89716 Vent Fitting
F(6 1/2 x 12)	<u>K523748 90010</u> Consists of: (1) K523748 End Cap (3) K84351 Cap Screws 1-1/8" (3) K523657 Seal Rings (1) K84324 Lock Plate	<u>K125685 90010</u> Consists of: (1) K125685 Backing Ring (1) K39716 Vent Fitting
G(7 x 12)	<u>K523750 90010</u> Consists of: (1) K523750 End Cap (3) K84398 Cap Screws 1-1/4" (3) K523658 Seal Rings (1) K84701 Lock Plate	<u>K83160 90010</u> Consists of: (1) K83160 Backing Ring (1) K89716 Vent Fitting

Backing Ring Without Flinger

NFL** End Cap



VENT FITTING

G(7x12)



VENT FITTING

E(6x11)
F(6 1/2 x 12)



VENT FITTING

B(4 1/4 x 8)
C(5 x 9)
D(5 1/2 x 10)



**NO FIELD LUBRICATION



OVERALL ASSEMBLIES NON-STANDARD "AP" BEARINGS - REDUCED WIDTH ASSEMBLIES

**CLASS-C (5 x 9)
HM124646-616XD-646XC**

OVERALL ASSEMBLIES			AUXILIARY PARTS		
CODE		BRG. MOUNTING ARRANGEMENT	QTY. AUXILIARY PART	PART NO.	ASSEMBLY NO.
STANDARD	350				
90116	90140	4*			
90132	--	2*	(1) Backing Ring	K85588	90010
90133	--	6*	(1) Recessed End Cap (1) Backing Ring	K399070 K85588	90010 90010
--	--	6-B*	(1) Recessed End Cap	K399070	

**CLASS-D (5-1/2 x 10)
HM127446-417XD-446XB**

OVERALL ASSEMBLIES			AUXILIARY PARTS		
CODE		BRG. MOUNTING ARRANGEMENT	QTY. AUXILIARY PART	PART NO.	ASSEMBLY NO.
STANDARD	350				
--	--	4*			
--	--	2*	(1) Backing Ring	K85525	90010
--	--	6*	(1) Recessed End Cap (1) Backing Ring	K399071 K85525	90010 90010
--	--	6-B*	(1) Recessed End Cap	K399071	90010

**CLASS-E (6 x 11)
HM129848-813XB -848XB**

OVERALL ASSEMBLIES			AUXILIARY PARTS		
CODE		BRG. MOUNTING ARRANGEMENT	QTY. AUXILIARY PART	PART NO.	ASSEMBLY NO.
STANDARD	350				
90176	--	4*			
90218	--	2*	(1) Backing Ring	K85095	90010
90219	--	6*	(1) Recessed End Cap (1) Backing Ring	K399072 K85095	90010 90010
90177	--	6-B*	(1) Recessed End Cap	K399072	90010

**CLASS-F (6-1/2 x 12)
HM133444-413XD-444XE**

OVERALL ASSEMBLIES			AUXILIARY PARTS		
CODE		BRG. MOUNTING ARRANGEMENT	QTY. AUXILIARY PART	PART NO.	ASSEMBLY NO.
STANDARD	350				
--	--	4*			
--	90190	2*	(1) Backing Ring	K85516	90010
--	--	6*	(1) Recessed End Cap (1) Backing Ring	K399073 K85516	90010 90010
--	--	6-B*	(1) Recessed End Cap	K399073	90010

*See Pages 1 and 2 for Bearing Mounting Arrangements

OVERALL ASSEMBLIES NON-STANDARD "AP" BEARINGS - SPECIAL CONE BORE SIZES

CLASS B (3-3/8) HMI20835-817XD-835XA

OVERALL ASSEMBLIES		BRG. MOUNTING ARRANGEMENT	AUXILIARY PARTS		
CODE	350		QTY. AUXILIARY PART	PART NO.	ASSEMBLY NO.
STANDARD					
90100	--	4*			
--	--	1*	(1) Axle End Cap (1) Backing Ring	K103535 K103528	90010
90017	--	1-A*	(1) Axle End Cap (1) Backing Ring	K103535 K103528	90010 90010
90018	--	2*	(1) Backing Ring	K103528	90010
--	--	3*	(1) Axle End Cap	K103535	
90101	--	3-A*	(1) Axle End Cap	K103535	90010

CLASS D(5) HMI27440-415XD-440XB

OVERALL ASSEMBLIES		BRG. MOUNTING ARRANGEMENT	AUXILIARY PARTS		
CODE	350		QTY. AUXILIARY PART	PART NO.	ASSEMBLY NO.
STANDARD					
--	--	4*			
--	--	1*	(1) Axle End Cap + (1) Backing Ring	K462066	
--	--	1A*	(1) Axle End Cap + (1) Backing Ring	K462066	
90130	--	2*	(1) Backing Ring	K462066	
--	--	3*	(1) Axle End Cap +		
--	--	3-A*	(1) Axle End Cap +		

+ Not Available

CLASS EE(6) H432649-614XD-649XA

OVERALL ASSEMBLIES		BRG. MOUNTING ARRANGEMENT	AUXILIARY PARTS		
CODE	350		QTY. AUXILIARY PART	PART NO.	ASSEMBLY NO.
STANDARD					
--	90014	4*			
90011	--	1*	(1) Axle End Cap (1) Backing Ring	K83094 K83088	90010 90010
--	--	1-A*	(1) Axle End Cap (1) Backing Ring	K83094 K83088	90010 90010
90012	--	2*	(1) Backing Ring	K83088	90010
--	--	3*	(1) Axle End Cap	K83094	90010
--	--	3-A*	(1) Axle End Cap	K83094	

OVERALL ASSEMBLIES NON-STANDARD "AP" BEARINGS - SPECIAL CONE BORE SIZES

CLASS G (6-3/16) HM136936-916XD-936XA

OVERALL ASSEMBLIES			AUXILIARY PARTS		
CODE		BRG. MOUNTING ARRANGEMENT	QTY. AUXILIARY PART	PART NO.	ASSEMBLY NO.
STANDARD	350				
90188	--	4*			
--	--	1*	(1) Axle End Cap	K98394+	
			(1) Backing Ring	K100636	90010
--	--	1-A*	(1) Axle End Cap	K98394+	
			(1) Backing Ring	K100636	90010
90016	--	2*	(1) Backing Ring	K100636	90010
--	--	3*	(1) Axle End Cap	K98394+	
--	--	3-A*	(1) Axle End Cap	K98394+	

+ Not available - PAS required.

CLASS G (6-1/2) HM136940-916XD-940XA

OVERALL ASSEMBLIES			AUXILIARY PARTS		
CODE		BRG. MOUNTING ARRANGEMENT	QTY. AUXILIARY PART	PART NO.	ASSEMBLY NO.
STANDARD	350				
90148	90134	4*			
--	--	1*	(1) Axle End Cap	K98394+	
			(1) Backing Ring	K100638	90010
90045	--	1-A*	(1) Axle End Cap	K98394+	
			(1) Backing Ring	K100638	90010
90018	--	2*	(1) Backing Ring	K100638	90010
--	--	3*	(1) Axle End Cap	K98394+	
--	--	3-A*	(1) Axle End Cap	K98394+	

+ Not available - PAS required.

CLASS GG (6-1/2) H337840-816XD-840XA

OVERALL ASSEMBLIES			AUXILIARY PARTS		
CODE		BRG. MOUNTING ARRANGEMENT	QTY. AUXILIARY PART	PART NO.	ASSEMBLY NO.
STANDARD	350				
90124	--	4*			
90133	90105	1*	(1) Axle End Cap	K82740	90013
			(1) Backing Ring	K100280	90010
--	--	1-A*	(1) Axle End Cap	K82740	90013
			(1) Backing Ring	K100280	90010
90084	90106	2*	(1) Backing Ring	K100280	90010
--	--	3*	(1) Axle End Cap	K82740	90013
--	--	3-A*	(1) Axle End Cap	K82740	90013

