

Helping you build a better machine, faster.

New Super Metric Ball Bushing* Bearings Technical Bulletin

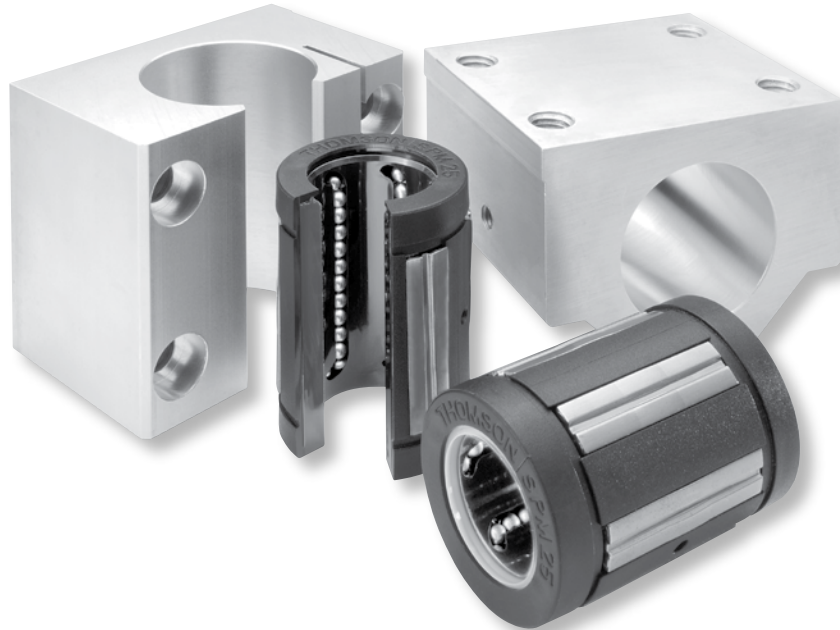

Super Metric Ball Bushing* Bearings



High performance from superior design:

- A coefficient of friction as low as 0,001. This allows the use of smaller less expensive motors, belts, gears and ball screws, when replacing high friction, plain bearings.
- A self-aligning capability up to 0,5° compensates for inaccuracies in base flatness or carriage machining. Achieved with Thomson Super Bearing plates which have defined radius crowns for maximized self-alignment accuracy.
- Accelerations as high as 150 m/s² and steady state travel speeds up to 3 m/s without the derating factors commonly required with linear guides.
- Double lip integral wipers that keep out dirt while retaining lubrication. Travel life is maximized.
- Light weight, wear-resistant, engineered polymer retainers and outer sleeves that reduce inertia and noise.
- Adjustable, closed and open configurations.

Quick to ship, drop-in replacement parts for existing applications:

- Dimensional interchangeable with competitive and legacy applications.
- Easy to order with local manufacturer's stock available in Europe and North America.
- Plus worldwide availability from over 1800 authorized distributors and direct from our manufacturing plants.

Genuine Thomson Quality:

- Thomson Ball Bushing bearings in combination with 60 Case* shafting last longer and carry significantly more load than conventional linear bearings, allowing you to reduce component size, saving space and cost. Thomson is the one and only name you'll need when choosing a round rail solution.
- To complete your application with genuine Thomson 60 Case shafting and shaft supports, please visit www.danahermotion.com/shafting.htm.
- Thomson is the innovator of linear bearings and has supplied superior quality product to the linear industry for 60 years. Superior Thomson quality translates into better reliability and performance.

* Trademark of Danaher Motion. DANAHER MOTION is registered in the U.S. Patent and Trademark Office and in other countries.

Super Metric Ball Bushing Bearings (Closed Type) for End Supported Applications

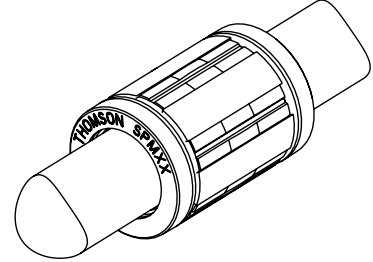
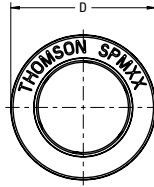
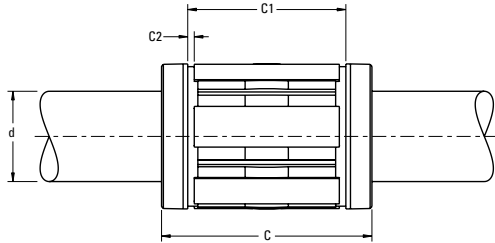

Super Metric Ball Bushing Bearings (Closed Type)

Part Number			Dimensions (mm)					Number of ball tracks	Mass (kg)	Dynamic Load $W^{(1)(3)}$ (N)	Load Limit $W_0^{(2)(3)}$ (N)
Without Integral Wipers	With One Integral Wiper	With Two Integral Wipers	$\phi d^{(4)}$	ϕD	C h14	C1 h13	C2 min				
SPM 08	SPM 08 W	SPM 08 WW	8	16	25	16.2	1.10	4	0.02	310	340
SPM 12	SPM 12 W	SPM 12 WW	12	22	32	22.6	1.30	5	0.02	830	910
SPM 16	SPM 16 W	SPM 16 WW	16	26	36	24.6	1.30	5	0.03	1020	1120
SPM 20	SPM 20 W	SPM 20 WW	20	32	45	31.2	1.60	6	0.06	2020	2220
SPM 25	SPM 25 W	SPM 25 WW	25	40	58	43.7	1.85	6	0.13	3950	4350
SPM 30	SPM 30 W	SPM 30 WW	30	47	68	51.7	1.85	6	0.19	4800	5280
SPM 40	SPM 40 W	SPM 40 WW	40	62	80	60.3	2.15	6	0.36	8240	9060
SPM 50	SPM 50 W	SPM 50 WW	50	75	100	77.3	2.65	6	0.66	12060	13270

- (1) For rated travel life of 100 km. For longer travel lives, reduce load to $W \cdot (100/L)^{0.33}$ where L (km) is the required travel life. Do not exceed the Dynamic Load Rating for travel life of less than 100 km.
- (2) The Load Limit is the maximum load that may be applied to a bearing and shaft. It is important to analyze the application so that peak and/or shock loads do not exceed the Load Limit.
- (3) The load capacities W and W_0 are valid for a resultant load applied at 90° with the ball tracks oriented as shown in the polar graphs below. If the resultant acts along another direction, the appropriate multiplicative correction factor K_θ should be applied to W and W_0 respectively.
- (4) Internal bearing diameter is affected by the housing bore, see Table 1.

NOTE: External seals and retaining rings are available. See Advanced Linear Motion Metric Components catalog for specifications.
 NOTE: For additional technical data, see the Engineering Support section of Advanced Linear Motion Metric Components catalog.
 NOTE: For a corrosion resistant bearing add suffix-CR to the part number and reduce the load capacity by 30%.

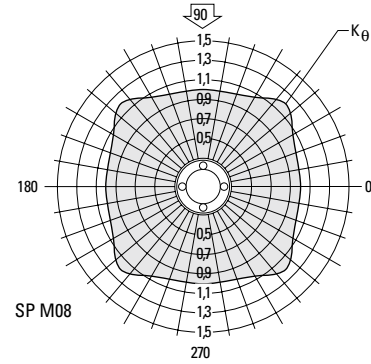
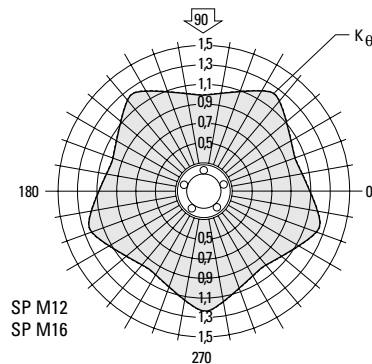
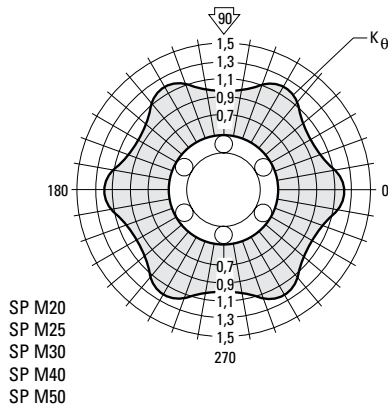

Super Metric Ball Bushing Bearings (Open Type) for Continuously Supported Applications

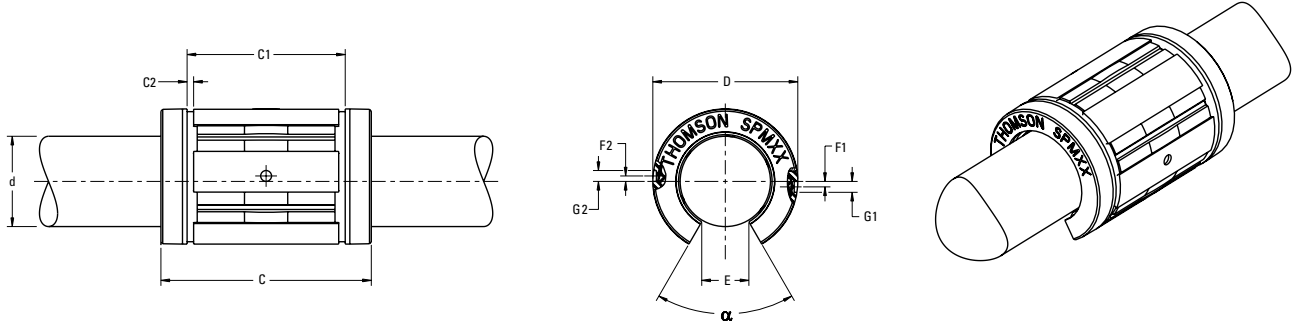

Super Metric Ball Bushing Bearings (Open Type)

Part Number			Dimensions (mm)										Angle α (deg)	Number of ball tracks	Mass (kg)	Dynamic Load $W^{(1)(3)}$ (N)	Load Limit $W_0^{(2)(3)}$ (N)
Without Integral Wipers	With One Integral Wiper	With Two Integral Wipers	$\phi d^{(4)}$	ϕD	C h14	C1 h13	C2 min	E $\pm 0,1$	F1	$\phi G1$	F2	$\phi G2$					
SPM 12 OPN	SPM 12 OPN W	SPM 12 OPN WW	12	22	32	22,3	1,30	7,0	1,35 ⁽⁵⁾	3,0	-	-	70	4	0,02	1060	1170
SPM 16 OPN	SPM 16 OPN W	SPM 16 OPN WW	16	26	36	24,6	1,30	9,8	0	3,0	-	-	70	4	0,02	1280	1410
SPM 20 OPN	SPM 20 OPN W	SPM 20 OPN WW	20	32	45	31,2	1,60	10,5	0	3,0	-	-	58	5	0,05	2100	2310
SPM 25 OPN	SPM 25 OPN W	SPM 25 OPN WW	25	40	58	43,7	1,85	13,0	1,50	3,0	0	3,5	60	5	0,10	4130	4540
SPM 30 OPN	SPM 30 OPN W	SPM 30 OPN WW	30	47	68	51,7	1,85	15,3	0	3,5	2,0	3,0	60	5	0,15	5020	5520
SPM 40 OPN	SPM 40 OPN W	SPM 40 OPN WW	40	62	80	60,3	2,15	21,4	0	3,5	1,5	3,0	58	5	0,30	8620	9480
SPM 50 OPN	SPM 50 OPN W	SPM 50 OPN WW	50	75	100	77,3	2,65	24,0	0	4,5	2,5	5,0	55	5	0,55	12500	13750

- For rated travel life of 100 km. For longer travel lives, reduce load to $W \cdot (100/L)^{0,33}$ where L (km) is the required travel life. Do not exceed the Dynamic Load Rating for travel life of less than 100 km.
 - The Load Limit is the maximum load that may be applied to a bearing and shaft. It is important to analyze the application so that peak and/or shock loads do not exceed the Load Limit.
 - The load capacities W and W_0 are valid for a resultant load applied at 90° with the ball tracks oriented as shown in the polar graphs below. If the resultant acts along another direction, the appropriate multiplicative correction factor K_θ should be applied to W and W_0 respectively. Open type bearings have reduced load capacities when used in pull-off situations.
 - Internal bearing diameter is affected by the housing bore, see Table 1.
 - Hole for anti-rotation pin is above centerline.
- NOTE: External seals and retaining are available. See Advanced Linear Motion Metric Components catalog for specifications.
 NOTE: For additional technical data, see the Engineering Support section of the Advanced Linear Motion Metric Components catalog.
 NOTE: For corrosion resistant bearing add suffix-CR to the part number and reduce the load capacity by 30%.

Table 1 - Standard Diametral Clearances

Nominal Shaft Diameter d (mm)	Nominal Housing Bore Diameter D (mm)	Diametral Clearance	
		Housing Bore H7 (μm)	Housing Bore H6 (μm)
12	22	+33 +4	+26 +3
16	26	+33 +4	+26 +3
20	32	+37 +6	+30 +4
25	40	+37 +6	+30 +4
30	47	+37 +6	+30 +4
40	62	+44 +7	+35 +5
50	75	+44 +7	+35 +5

For Super Metric Ball Bushing bearings mounted in a housing and with LinearRace® shafts, h6 tolerance

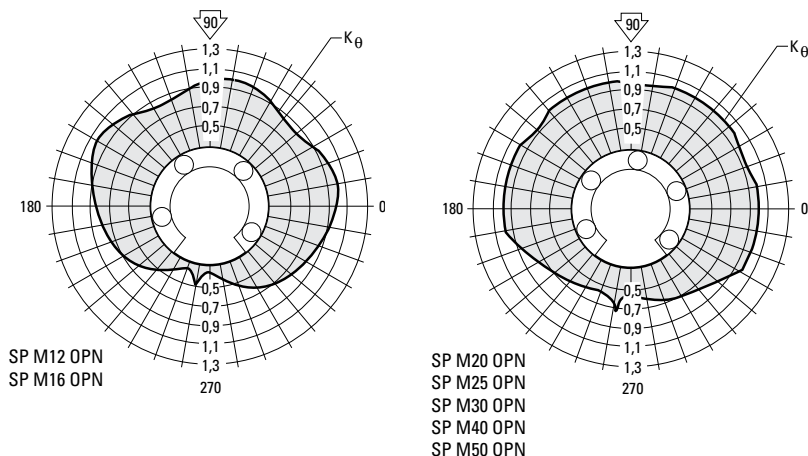

* Trademark of Danaher Motion. DANAHER MOTION is registered in the U.S. Patent and Trademark Office and in other countries.

Super Metric Pillow Blocks



Thomson Pillow Blocks with factory-installed Super Metric Ball Bushing bearings offer:

- Accelerations as high as 150 m/s^2 and steady state travel speeds up to 3 m/s without the derating factors commonly required with linear guides.
- Replaceable bearing components for quick, cost-effective machine maintenance and minimal downtime.
- Light weight, wear-resistant, engineered polymer retainers and outer sleeves that reduce inertia and noise.
- Standard, double-acting, integral seals at both ends which keep out dirt, grit and other contaminants, retain lubrication and maximize bearing life.
- Lubrication hole for easy maintenance.
- Tapped or thru hole mounting configuration for ease of installation.
- Twin version with two Super Ball Bushing bearings providing twice the load capacity or 8 times more travel life than the single version.
- A single bearing version that self aligns in all directions, minimizing installation time and cost.

Note: See page 2 for information on Thomson Super Metric Ball Bushing bearings.

Super Metric Pillow Blocks (Closed Type) for End Supported Applications

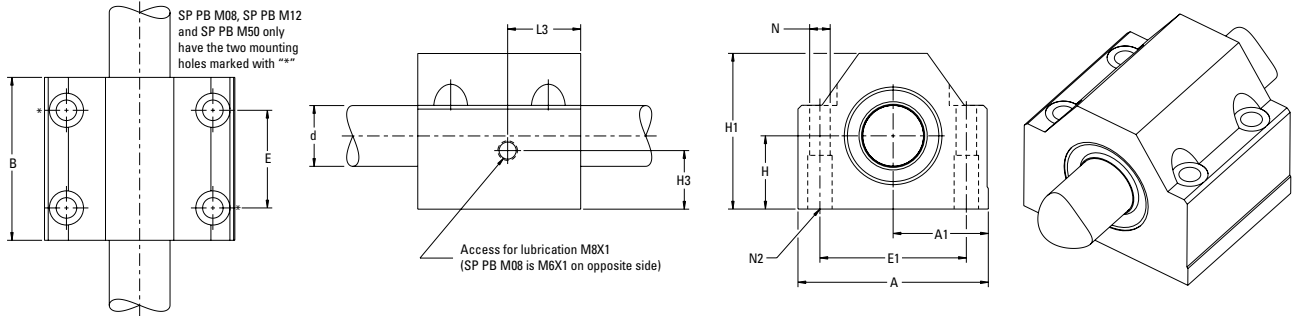

Super Pillow Blocks (Closed Type)

Part Number	Dimensions (mm)												Mass (kg)	Dynamic Load $W^{(1)(3)}$ (N)	Load Limit $W_0^{(2)(3)}$ (N)
	$\varnothing d^{(4)}$	H $\pm 0,020$	H1	A	A1 $\pm 0,020$	B	E $\pm 0,1$	E1 $\pm 0,1$	H3	L3 ⁽⁵⁾	$\varnothing N$	N2			
SP PB M08	8	15	28	35	17,5	32	20 ⁽⁶⁾	25 ⁽⁶⁾	12 ⁽⁵⁾	8,5	3,3	M4	0,07	310	340
SP PB M12	12	18	35	43	21,5	39	23 ⁽⁶⁾	32 ⁽⁶⁾	10	10,5	4,3	M5	0,13	830	910
SP PB M16	16	22	42	53	26,5	43	26	40	16	15,7	5,3	M6	0,21	1020	1120
SP PB M20	20	25	50	60	30,0	54	32	45	13	20	6,6	M8	0,35	2020	2220
SP PB M25	25	30	60	78	39,0	67	40	60	15	23	8,4	M10	0,66	3950	4350
SP PB M30	30	35	71	87	43,5	79	45	68	16	26,5	8,4	M10	0,97	4800	5280
SP PB M40	40	45	91	108	54,0	91	58	86	21,5	30	10,5	M12	1,81	8240	9060
SP PB M50	50	50	105	132	66,0	113	50	108	12,5	22	13,5	M16	3,00	12060	13270

- (1) For rated travel life of 100 km. For longer travel lives, reduce load to $W \cdot (100/L)^{0,33}$ where L (km) is the required travel life. Do not exceed the Dynamic Load Rating for travel life of less than 100 km.
- (2) The Load Limit is the maximum load that may be applied to a bearing and shaft. It is important to analyze the application so that peak and/or shock loads do not exceed the Load Limit.
- (3) The load capacities W and W_0 are valid for a resultant load applied at 90° with the ball tracks oriented as shown in the polar graphs below. If the resultant acts along another direction, the appropriate multiplicative correction factor K_θ should be applied to W and W_0 respectively.
- (4) For bearing diametral clearances, see Table 2.
- (5) SP PB M08 lube hole is M6X1 tapped hole located on opposite side
- (6) SP PB M08, SP PB M12 and SP PB M50 pillow blocks have only 2 mounting holes. The mounting holes on these sizes are marked in the chart above with "*"

Table 2 - Standard Diametral Clearances (Closed Type)

Nominal Size d (mm)	Diametral Clearance (μm)
8	+23 +2
12	+26 +3
16	+26 +3
20	+30 +4
25	+30 +4
30	+30 +4
40	+35 +5
50	+35 +5

For Pillow Blocks used with LinearRace Shaft, h6 tolerance

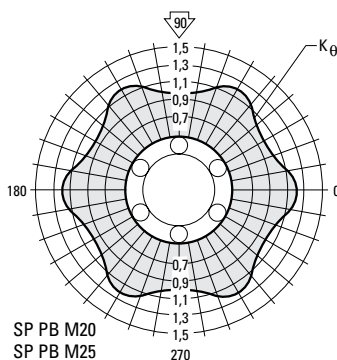

SP PB M20
SP PB M25
SP PB M30
SP PB M40
SP PB M50

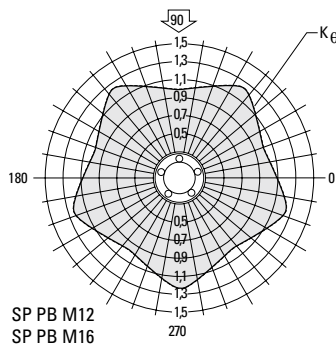

SP PB M12
SP PB M16

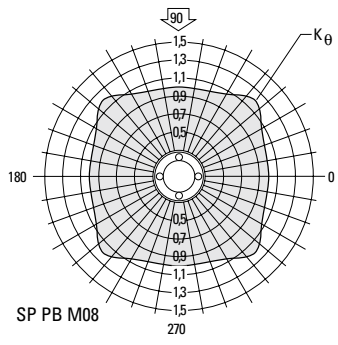

SP PB M08

Super Metric Pillow Blocks (Closed Adjustable Type) for End Supported Applications

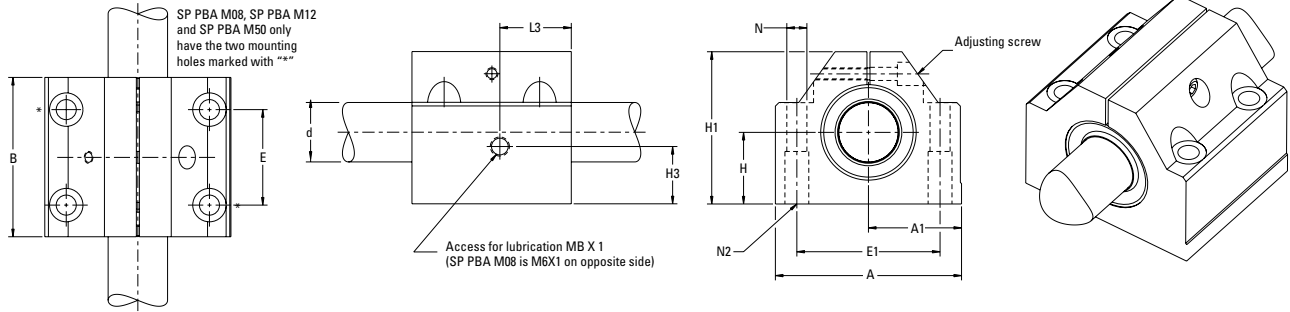

Super Pillow Blocks (Closed Adjustable Type)

Part Number	Dimensions (mm)												Mass (kg)	Dynamic Load $W^{(1)(3)}$ (N)	Load Limit $W_0^{(2)(3)}$ (N)
	$\varnothing d$	H $\pm 0,020$	H1	A	A1 $\pm 0,020$	B	E $\pm 0,1$	E1 $\pm 0,1$	H3	L3	$\varnothing N$	N2			
SP PBA M08	8	15	28	35	17,5	32	20 ⁽⁶⁾	25 ⁽⁶⁾	12 ⁽⁶⁾	8,5 ⁽⁶⁾	3,3	M4	0,07	310	340
SP PBA M12	12	18	35	43	21,5	39	23 ⁽⁶⁾	32 ⁽⁶⁾	10	10,5	4,3	M5	0,13	830	910
SP PBA M16	16	22	42	53	26,5	43	26	40	16	15,7	5,3	M6	0,21	1020	1120
SP PBA M20	20	25	50	60	30,0	54	32	45	13	20	6,6	M8	0,35	2020	2220
SP PBA M25	25	30	60	78	39,0	67	40	60	15	23	8,4	M10	0,66	3950	4350
SP PBA M30	30	35	71	87	43,5	79	45	68	16	26,5	8,4	M10	0,97	4800	5280
SP PBA M40	40	45	91	108	54,0	91	58	86	21,5	30	10,5	M12	1,81	8240	9060
SP PBA M50	50	50	105	132	66,0	113	50	108	12,5	22	13,5	M16	3,00	12060	13270

- (1) For rated travel life of 100 km. For longer travel lives, reduce load to $W \cdot (100/L)^{0,33}$ where L (km) is the required travel life. Do not exceed the Dynamic Load Rating for travel life of less than 100 km.
- (2) The Load Limit is the maximum load that may be applied to a bearing and shaft. It is important to analyze the application so that peak and/or shock loads do not exceed the Load Limit.
- (3) The load capacities W and W_0 are valid for a resultant load applied at 90° with the ball tracks oriented as shown in the polar graphs below. If the resultant acts along another direction, the appropriate multiplicative correction factor K_θ should be applied to W and W_0 respectively.
- (4) For bearing diametral clearances, see Table 2.
- (5) SP PBA M08 lube hole is M6X1 tapped hole located on opposite side
- (6) SP PBA M08, SP PBA M12 and SP PBA M50 pillow blocks have only 2 mounting holes. The mounting holes on these sizes are marked in the chart above with "***"

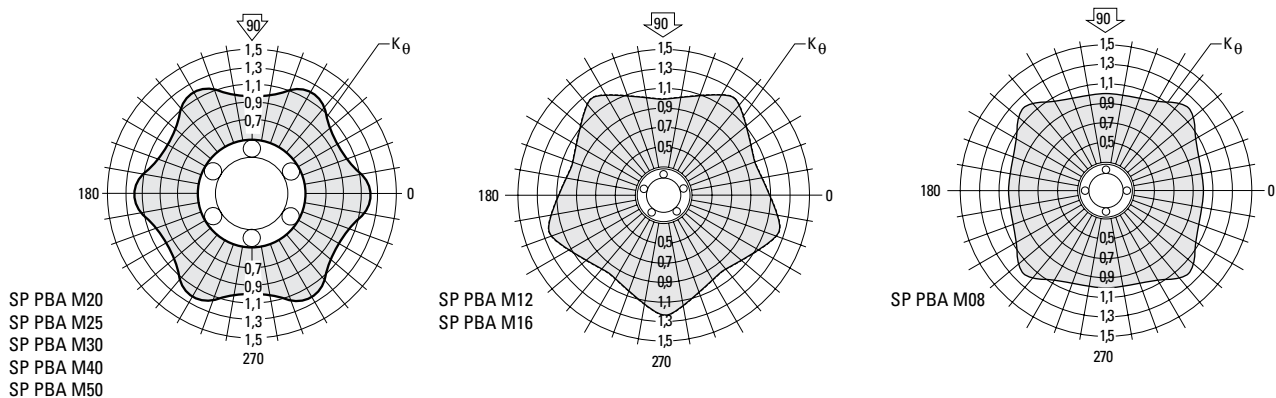

Super Metric Pillow Blocks (Open Type) for Continuously Supported Applications

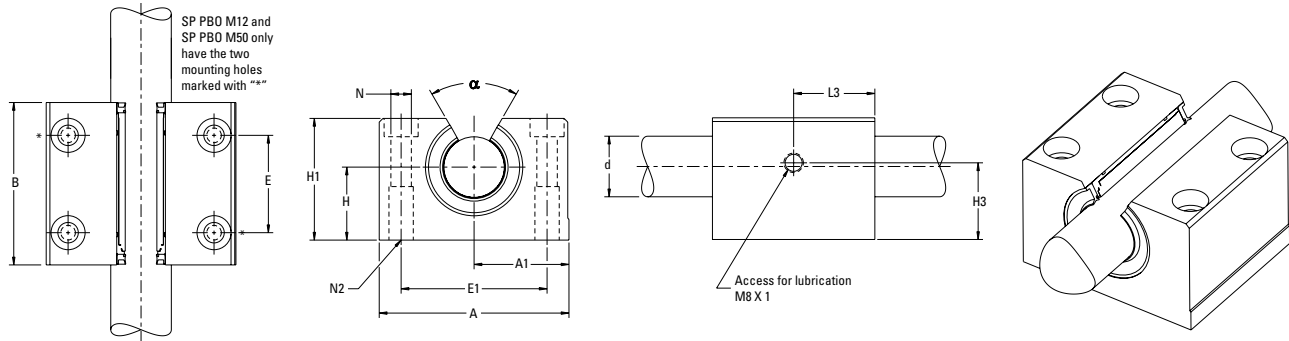

Super Pillow Blocks (Open Type)

Part Number	Dimensions (mm)												Angle α (deg)	Mass (kg)	Dynamic Load $W^{(1)(3)}$ (N)	Load Limit $W_0^{(2)(3)}$ (N)
	$\varnothing d^{(4)}$	H $\pm 0,020$	H1	A	A1 $\pm 0,020$	B	E $\pm 0,1$	E1 $\pm 0,1$	H3	L3	$\varnothing N$	N2				
SP PBO M12	12	18	35	43	21,5	39	23 ⁽⁶⁾	32 ⁽⁶⁾	10	10,5	4,3	M5	70	0,11	1060	1170
SP PBO M16	16	22	42	53	26,5	43	26	40	10,8	15,7	5,3	M6	58	0,19	1280	1410
SP PBO M20	20	25	50	60	30,0	54	32	45	13	20	6,6	M8	60	0,30	2100	2310
SP PBO M25	25	30	60	78	39,0	67	40	60	15	23	8,4	M10	60	0,60	4130	4540
SP PBO M30	30	35	71	87	43,5	79	45	68	20,5	27	8,4	M10	58	0,92	5020	5520
SP PBO M40	40	45	91	108	54,0	91	58	86	21,5	30	10,5	M12	55	1,65	8620	9480
SP PBO M50	50	50	113	132	66,0	113	50	108	12,5	22	13,5	M16	55	2,60	12500	13750

- (1) For rated travel life of 100 km. For longer travel lives, reduce load to $W \cdot (100/L)^{0,33}$ where L (km) is the required travel life. Do not exceed the Dynamic Load Rating for travel life of less than 100 km.
- (2) The Load Limit is the maximum load that may be applied to a bearing and shaft. It is important to analyze the application so that peak and/or shock loads do not exceed the Load Limit.
- (3) The load capacities W and W_0 are valid for a resultant load applied at 90° with the ball tracks oriented as shown in the polar graphs below. If the resultant acts along another direction, the appropriate multiplicative correction factor K_θ should be applied to W and W_0 respectively. Open type bearings have reduced load capacities when used in pull-off situations.
- (4) For bearing diametral clearances, see Table 3.
- (5) SP PBO M12 and SP PBO M50 pillow blocks have only 2 mounting holes. The mounting holes on these sizes are marked in the chart above with "*".

Table 3 - Standard Diametral Clearances (Open Type)

Nominal Size d (mm)	Diametral Clearance (μm)
12	+26 +3
16	+26 +3
20	+30 +4
25	+30 +4
30	+30 +4
40	+35 +5
50	+35 +5

For Pillow Blocks used with Linear-Race Shaft, h6 tolerance

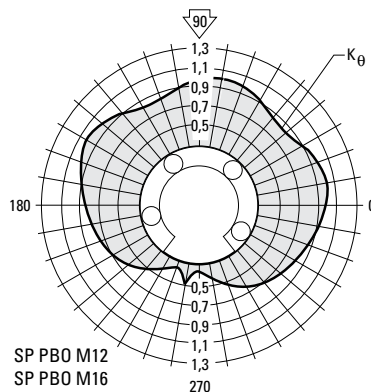

SP PBO M12
SP PBO M16

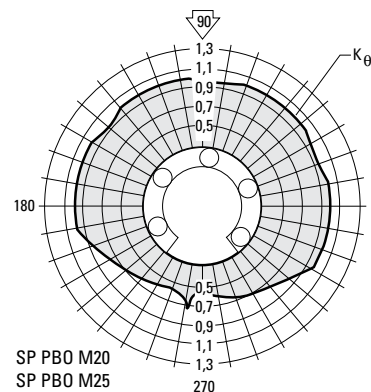

SP PBO M20
SP PBO M25
SP PBO M30
SP PBO M40
SP PBO M50

Super Metric Pillow Blocks (Open Adjustable Type) for Continuously Supported Applications

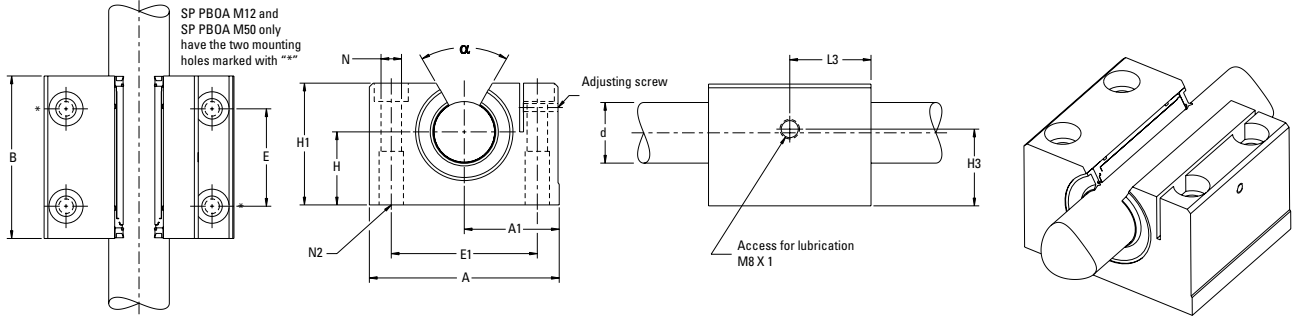

Super Pillow Blocks (Open Adjustable Type)

Part Number	Dimensions (mm)												Angle α (deg)	Mass (kg)	Dynamic Load $W^{(1)(3)}$ (N)	Load Limit $W_0^{(2)(3)}$ (N)
	$\varnothing d$	H $\pm 0,020$	H1	A	A1 $\pm 0,020$	B	E $\pm 0,1$	E1 $\pm 0,1$	H3	L3	$\varnothing N$	N2				
SP PBOA M12 ⁽⁴⁾	12	18	35	43	21,5	39	23	32	10	10,5	4,3	M5	70	0,11	1060	1170
SP PBOA M16	16	22	42	53	26,5	43	26	40	10,8	15,7	5,3	M6	58	0,19	1280	1410
SP PBOA M20	20	25	50	60	30,0	54	32	45	13	20	6,6	M8	60	0,30	2100	2310
SP PBOA M25	25	30	60	78	39,0	67	40	60	15	23	8,4	M10	60	0,60	4130	4540
SP PBOA M30	30	35	71	87	43,5	79	45	68	20,5	27	8,4	M10	58	0,92	5020	5520
SP PBOA M40	40	45	91	108	54,0	91	58	86	21,5	30	10,5	M12	55	1,65	8620	9480
SP PBOA M50	50	50	113	132	66,0	113	50	108	12,5	22	13,5	M16	55	2,60	12500	13750

- (1) For rated travel life of 100 km. For longer travel lives, reduce load to $W \cdot (100/L)^{0,33}$ where L (km) is the required travel life. Do not exceed the Dynamic Load Rating for travel life of less than 100 km.
- (2) The Load Limit is the maximum load that may be applied to a bearing and shaft. It is important to analyze the application so that peak and/or shock loads do not exceed the Load Limit.
- (3) The load capacities W and W_0 are valid for a resultant load applied at 90° with the ball tracks oriented as shown in the polar graphs below. If the resultant acts along another direction, the appropriate multiplicative correction factor K_θ should be applied to W and W_0 respectively. Open type bearings have reduced load capacities when used in pull-off situations.
- (4) SP PBOA M12 and SP PBOA M50 pillow blocks have only 2 mounting holes. The mounting holes on these sizes are marked in the chart above with "***"

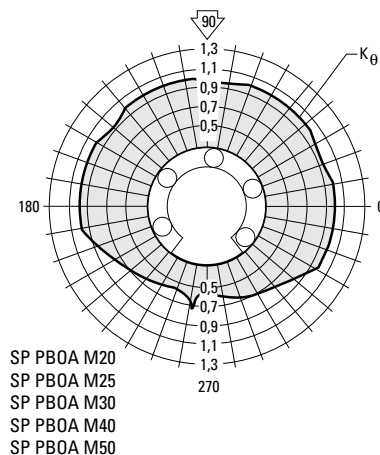
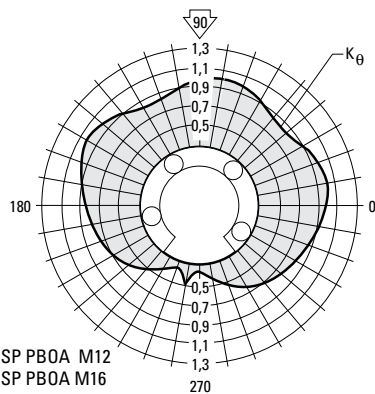

Super Metric Twin Pillow Blocks (Closed Type) for End Supported Applications

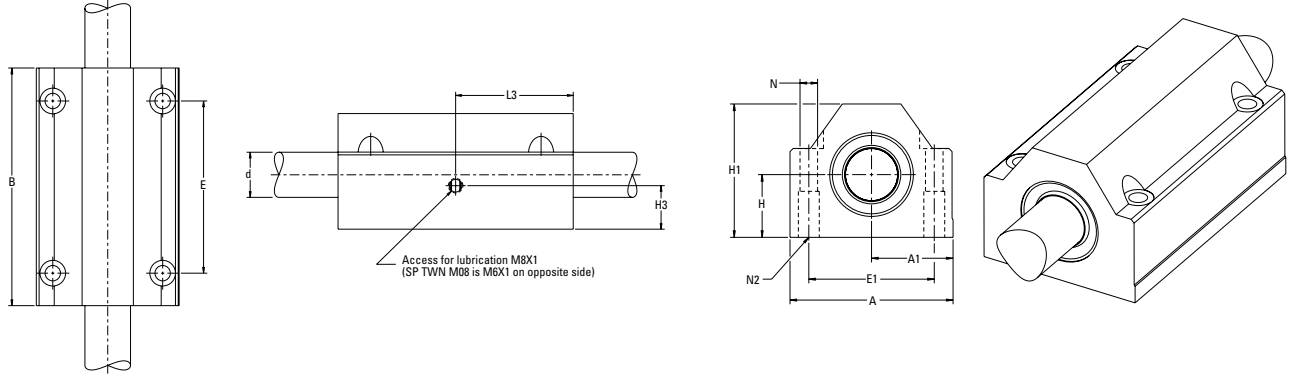

Part Number	Dimensions (mm)												Mass (kg)	Dynamic Load $W^{(1)(3)}$ (N)	Load Limit $W_0^{(2)(3)}$ (N)
	$\varnothing d^{(4)}$	H $\pm 0,020$	H1	A	A1 $\pm 0,020$	B	E $\pm 0,1$	E1 $\pm 0,1$	H3	L3	$\varnothing N$	N2			
SP TWN M08	8	15	28	35	17,5	62	50	25	12 ⁽⁵⁾	31 ⁽⁵⁾	3,3	M4	0,15	500	550
SP TWN M12	12	18	35	43	21,5	76	56	32	10	38	4,3	M5	0,27	1350	1490
SP TWN M16	16	22	42	53	26,5	84	64	40	16	42	5,3	M6	0,41	1660	1830
SP TWN M20	20	25	50	60	30,0	104	76	45	13	52	6,6	M8	0,66	3280	3610
SP TWN M25	25	30	60	78	39,0	130	94	60	15	65	8,4	M10	1,22	6410	7050
SP TWN M30	30	35	71	87	43,5	152	106	68	16	76	8,4	M10	1,90	7800	8580
SP TWN M40	40	45	91	108	54,0	176	124	86	21,5	88	10,5	M12	3,57	13380	14720
SP TWN M50	50	50	105	132	66,0	224	160	108	20	112	13,5	M16	6,30	19590	21550

(Closed Adjustable Type) for End Supported Applications

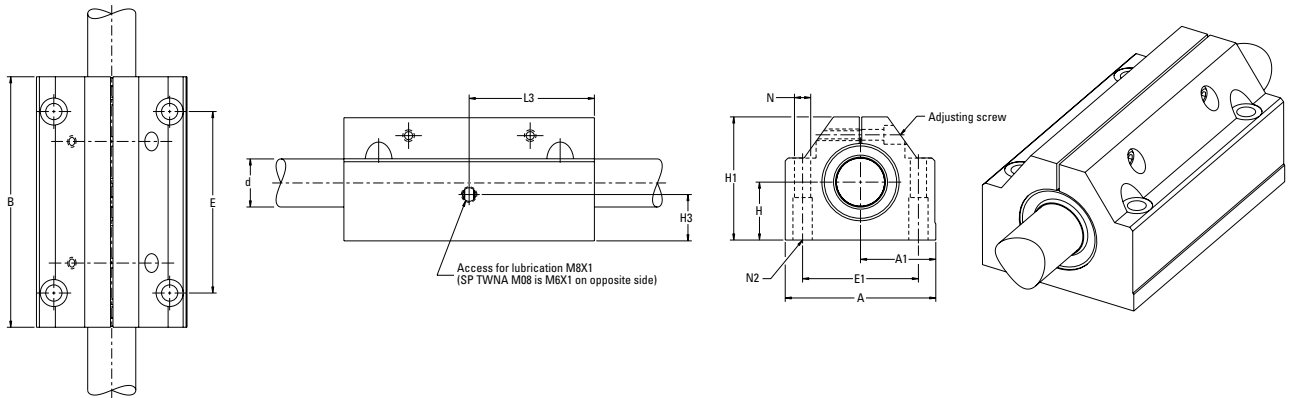

Part Number	Dimensions (mm)												Mass (kg)	Dynamic Load $W^{(1)(3)}$ (N)	Load Limit $W_0^{(2)(3)}$ (N)
	$\varnothing d$	H $\pm 0,020$	H1	A	A1 $\pm 0,020$	B	E $\pm 0,1$	E1 $\pm 0,1$	H3	L3	$\varnothing N$	N2			
SP TWNA M08	8	15	28	35	17,5	62	50	25	12 ⁽⁵⁾	31 ⁽⁵⁾	3,3	M4	0,15	500	550
SP TWNA M12	12	18	35	43	21,5	76	56	32	10	38	4,3	M5	0,27	1350	1490
SP TWNA M16	16	22	42	53	26,5	84	64	40	12	42	5,3	M6	0,41	1660	1830
SP TWNA M20	20	25	50	60	30,0	104	76	45	13	52	6,6	M8	0,66	3280	3610
SP TWNA M25	25	30	60	78	39,0	130	94	60	15	65	8,4	M10	1,22	6410	7050
SP TWNA M30	30	35	71	87	43,5	152	106	68	20	76	8,4	M10	1,90	7800	8580
SP TWNA M40	40	45	91	108	54,0	176	124	86	21,5	88	10,5	M12	3,57	13380	14720
SP TWNA M50	50	50	105	132	66,0	224	160	108	20	112	13,5	M16	6,30	19590	21550

See footnotes (1) (2) (3) (4) (5) on page 6. For diametral clearances, see single versions of pillow block.

Super Metric Twin Pillow Blocks (Open Type) for Continuously Supported Applications

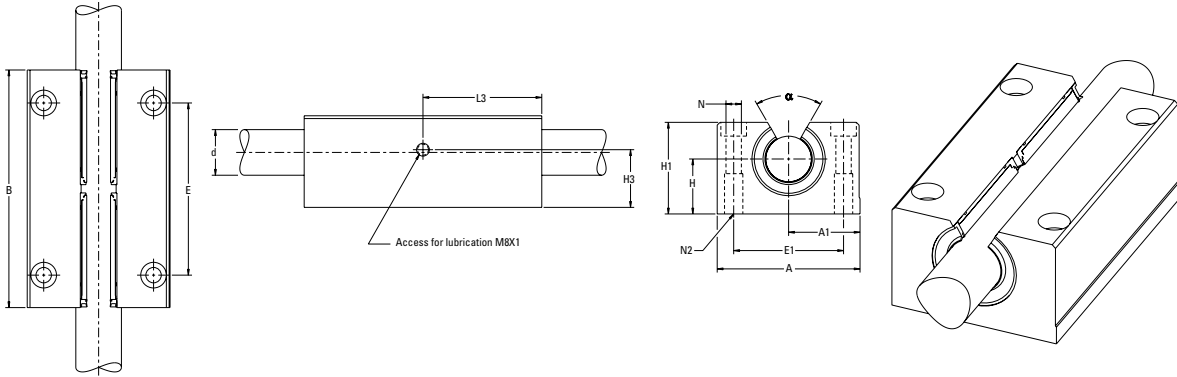

Part Number	Dimensions (mm)												Angle α (deg)	Mass (kg)	Dynamic Load $W^{(1)(3)}$ (N)	Load Limit $W_0^{(2)(3)}$ (N)
	$\varnothing d^{(4)}$	H $\pm 0,020$	H1	A	A1 $\pm 0,020$	B	E $\pm 0,1$	E1 $\pm 0,1$	H3	L3	$\varnothing N$	N2				
SP TWNO M12	12	18	28	43	21.5	76	56	32	10	38	4,3	M5	70	0,22	1350	1490
SP TWNO M16	16	22	35	53	26.5	84	64	40	18	42	5,3	M6	58	0,37	1660	1830
SP TWNO M20	20	25	41	60	30.0	104	76	45	16	52	6,6	M8	60	0,57	3280	3610
SP TWNO M25	25	30	50	78	39.0	130	94	60	15	65	8,4	M10	60	1,15	6410	7050
SP TWNO M30	30	35	60	87	43.5	152	106	68	16	76	8,4	M10	58	1,76	7800	8580
SP TWNO M40	40	45	77	108	54.0	176	124	86	21,5	88	10,5	M12	55	3,22	13380	14720
SP TWNO M50	50	50	88	130	66.0	224	160	108	20	112	13,5	M16	55	5,50	19590	21550

(Open Adjustable Type) for Continuously Supported Applications

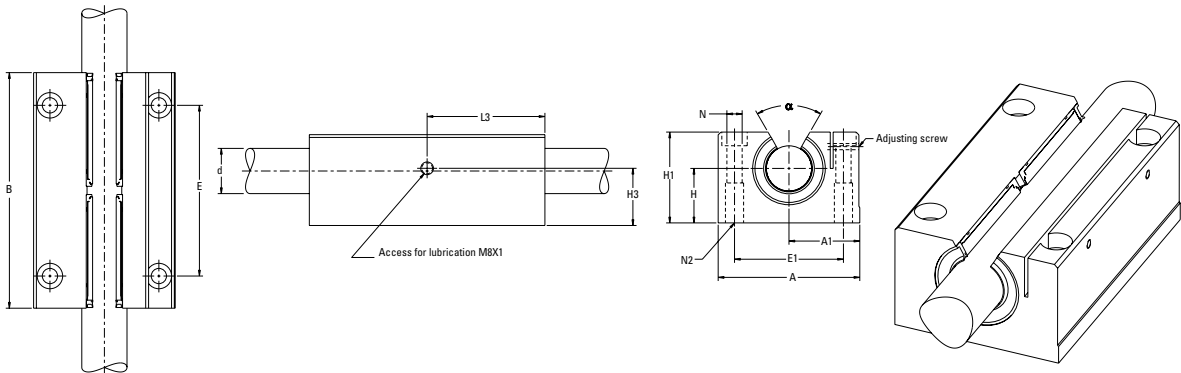

Part Number	Dimensions (mm)												Angle α (deg)	Mass (kg)	Dynamic Load $W^{(1)(3)}$ (N)	Load Limit $W_0^{(2)(3)}$ (N)
	$\varnothing d$	H $\pm 0,020$	H1	A	A1 $\pm 0,020$	B	E $\pm 0,1$	E1 $\pm 0,1$	H3	L3	$\varnothing N$	N2				
SP TWNOA M12	12	18	28	43	21.5	76	56	32	10	38	4,3	M5	70	0,22	1350	1490
SP TWNOA M16	16	22	35	53	26.5	84	64	40	18	42	5,3	M6	58	0,37	1660	1830
SP TWNOA M20	20	25	41	60	30.0	104	76	45	16	52	6,6	M8	60	0,57	3280	3610
SP TWNOA M25	25	30	50	78	39.0	130	94	60	15	65	8,4	M10	60	1,15	6410	7050
SP TWNOA M30	30	35	60	87	43.5	152	106	68	16	76	8,4	M10	58	1,76	7800	8580
SP TWNOA M40	40	45	77	108	54.0	176	124	86	21,5	88	10,5	M12	55	3,22	13380	14720
SP TWNOA M50	50	50	88	130	66.0	224	160	108	20	112	13,5	M16	55	5,50	19590	21550

See footnotes (1) (2) (3) (4) on page 8. For diametral clearances, see single versions of pillow block.

USA, Canada and Mexico

Danaher Motion
203A West Rock Road
Radford, VA 24141 USA
Phone: 1-540-633-3400
Fax: 1-540-639-4162
E-mail: DMAC@danahermotion.com

United Kingdom

Danaher Motion
Chartmoor Road, Chartwell Business Park
Leighton Buzzard, Bedfordshire
LU7 4WG; United Kingdom
Phone: +44 (0)1525 243 243
Fax: +44 (0)1525 243 244
E-mail: sales.uk@danahermotion.com

Germany

Danaher Motion GmbH
Sales Office North
Wacholderstr. 40-42
40489 Düsseldorf
Germany
Phone: +49 (0) 203 9979 214
Fax: +49 (0) 203 9979 3214
E-mail: iris.tolusch@danahermotion.com

Danaher Motion GmbH
Sales Office South West
Brückenfeldstraße 26/1
75015 Bretten
Germany
Phone: +49 (0) 7252 96462 10
Fax: +49 (0) 7252 96462 69
E-mail: kerstin.mueller@danahermotion.com

Danaher Motion GmbH
Sales Office South East
Kiesgräble 7
89129 Langenau
Germany
Phone: +49 (0) 7471 62 23 23
Fax: +49 (0) 7471 62 23 26
E-mail: ursula.koschak@danahermotion.com

France

Danaher Motion
C.P 80018
12, Rue Antoine Becquerel – Z.I. Sud
72026 Le Mans Cedex 2
France
Phone: +33 (0) 243 50 03 30
Fax: +33 (0) 243 50 03 39
E-mail: sales.france@danahermotion.com

Italy

Danaher Motion srl
Largo Brughetti
20030 Bovisio Masciago
Italy
Phone: +39 0362 594260
Fax: +39 0362 594263
E-mail: info@danahermotion.it

Sweden

Danaher Motion
Box 9053
291 09 Kristianstad
Sweden
Phone: +46 (0) 44-24 67 00
Fax: +46 (0) 44-24 40 85
E-mail: sales.scandinavia@danahermotion.com

Switzerland

Danaher Motion SA
La Pierreire 2
1029 Villars-Ste-Croix
Switzerland
Phone: +41 (0) 21 631 33 33
Fax: +41 (0) 21 636 05 09
E-mail: info@danaher-motion.ch

China

Danaher Motion
Rm 2205, Scitech Tower
22 Jianguomen Wai Street
Beijing, China, 100004
Phone: +86 10 6515 0260
Fax: +86 10 6515 0263
E-mail: chinainfo@danahermotion.com.cn

Japan

Danaher Motion Japan
2F, Tokyu Reit Hatchobori Bldg,
2-7-1 Hatchobori Chuo-ku,
Tokyo 104-0032 Japan
Phone: +81-3-6222-1051
Fax: +81-3-6222-1055
E-mail: info@danahermotion.co.jp

Asia Pacific

Danaher Motion (HK) Ltd
Unit A, 16 Floor, 169 Electric Road
Manulife Tower, North Point
Hong Kong
Phone: +852 2503 6581
Fax: +852 2571 8585
E-mail: victor.lim@danahermotion.com