



Helping you build a better machine, faster.

New Stainless Steel Ball Bushing* Bearings Technical Bulletin



Benefits of Thomson Stainless Steel MultiTrac Ball Bushing* Bearing and Stainless Steel “A” Ball Bushing* Bearing Products:



Ideal for harsh environments:

- Stainless steel (440) components resist rust and corrosion.
- “A” bearing withstands up to 600 degrees F (315°C).
- MultiTrac Ball Bushing bearings are rated at a maximum of 180 degrees F (82°C)
- MultiTrac has wear-resistant, engineered-polymer retainers to reduce inertia and noise levels.

High performance from superior design:

- A coefficient of friction as low as 0.001. This allows the use of smaller less expensive motors, belts, gears and ball screws, when replacing high friction, plain bearings.
- Steady state travel speeds up to 10 ft/s (3 m/s) and accelerations to 450 ft/s² (150 m/s²) without the use of derating factors.
- Adjustable, closed and open configurations.
- MultiTrac only: offers a patented multiple-track design with up to twice the load carrying capacity, or 8 times the life, of conventional linear bearings. Patented ball control technology which eliminates binding and chatter (stick-slip) common to high friction, plain bushings and sliding-way bearings.
- “A” Bearing only: all-steel construction, for maximum system rigidity. Two accuracy classes allowing for immediate improvements in system positioning and repeatability. Availability in a self-aligning pillow block housing for ease of installation and use.

Quick to ship, drop-in replacement parts for existing applications:

- Industry standard dimensions for direct interchange with competitive and legacy applications.
- Easy to order with local stock available in Europe and North America.
- Plus worldwide availability from over 1800 authorized distributors.

Genuine Thomson Quality:

- Thomson invented anti-friction linear bearings and has supplied superior quality product to the linear industry for 60 years. Superior Thomson quality translates into better reliability and performance.
- To complete your application with genuine Thomson 60 Case* shafting and shaft supports, please visit www.danahermotion.com/shafting.htm
- Thomson Ball Bushing bearings in combination with 60 Case shafting last longer and carry significantly more load than conventional linear bearings, allowing you to reduce component size, saving space and cost. Thomson is the one and only name you'll need when choosing a round rail solution.

* Trademark of Danaher Motion. DANAHER MOTION is registered in the U.S. Patent and Trademark Office and in other countries.

Stainless Steel MultiTrac Ball Bushing Bearings

Our Thomson MultiTrac Ball Bushing bearings are designed with greater rigidity and up to twice the load capacity of conventional linear bearings. The design incorporates a one-piece, bearing quality steel sleeve (see Figure 1) for maximum rigidity. The single-piece engineered polymer ball retainer provides smooth, quiet operation.

Corrosion Resistant

The MultiTrac Ball Bushing bearing incorporates 440 stainless bearing steels with a proprietary polymer guide system. This provides excellent performance in harsh environments where carbon steel is not desirable.

Twice the Load Capacity

The bearing's load capacity is improved by the optimal positioning of the load tracks. This places the maximum number of load-bearing balls in the load zone (see Figure 1).

High Speed Operation

The advanced design also improves the bearing's ball control. This allows accelerations as high as 150 m/s² and travel speeds up to 3 m/s.

Integral Seals

The bearing includes double acting integral wipers, which keep out dirt, grit and other contaminants, and retain bearing lubrication.

Improved Ball Control

Through advanced computer-aided design techniques, ball control improvements assure smooth entry and exit of the balls in and out of the load zone.

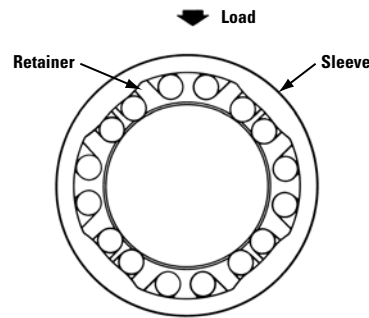

Figure 1

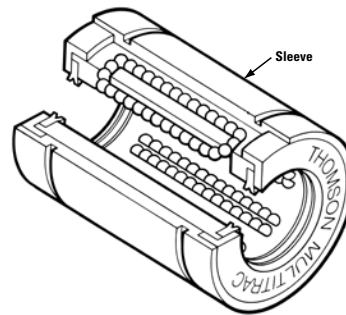
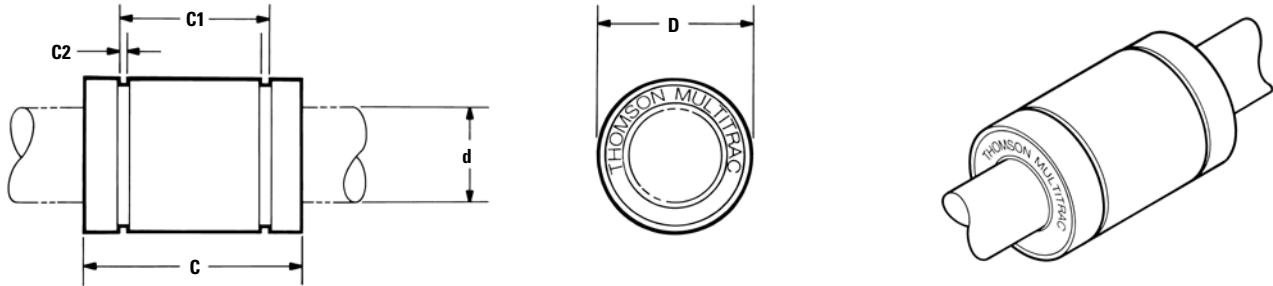

Figure 2

MultiTrac Ball Bushing Bearings

Closed Type



Part Number			Dimensions (mm)					Number of Ball Tracks	Mass (kg)	Dynamic Load W ⁽¹⁾⁽³⁾ (N)	Load Limit W ₀ ⁽²⁾⁽³⁾ (N)
Without Integral Wipers	With One Integral Wiper	With Two Integral Wipers	∅ d ⁽⁴⁾	∅ D	C h14	C1 H13	C2 min.				
MAM08SS	MAM08WSS	MAM08WWSS	8	16	25	16,2	1,10	4	0,02	140	260
MAM12SS	MAM12WSS	MAM12WWSS	12	22	32	22,6	1,30	6	0,04	280	700
MAM16SS	MAM16WSS	MAM16WWSS	16	26	36	24,6	1,30	8	0,06	440	1040
MAM20SS	MAM20WSS	MAM20WWSS	20	32	45	31,2	1,60	8	0,11	800	1890
MAM25SS	MAM25WSS	MAM25WWSS	25	40	58	43,7	1,85	8	0,20	1580	4080
MAM30SS	MAM30WSS	MAM30WWSS	30	47	68	51,7	1,85	8	0,33	1650	4640

- (1) For rated travel life of 100 km. For longer travel lives, reduce load to $W \cdot (100/L)^{0.33}$ where L (km) is the required travel life. Do not exceed the Dynamic Load Rating for travel life of less than 100 km.
 - (2) The load Limit is the maximum load that may be applied to a bearing and shaft. It is important to analyze the application so that peak and/or shock loads do not exceed the Load Limit.
 - (3) The load capacities W and W₀ are valid for a resultant load applied at 90° with the ball tracks oriented as shown in the polar graphs below. If the resultant acts along another direction, the appropriate multiplicative correction factor, K_φ, should be applied to W and W₀ respectively. Open type bearings have reduced load capacities when used in pull-off situations.
 - (4) For diametral clearance, see Table 1.
- NOTE: External seals and retaining rings are available. See Advanced Linear Motion Metric Components catalog, pages 42,43 for specifications.
 NOTE: For additional technical data, see the Engineering Support section of the Advanced Linear Motion Metric Components catalog.

Table 1: Standard Diametral Clearance - Closed Type

Nominal Size d (mm)	Diametral Clearance (µm)	
8	+15	+3
12	+19	+3
16	+19	+3
20	+22	+4
25	+22	+4
30	+22	+4

For closed type bearings with LinearRace™ Shaft, h6 tolerance.

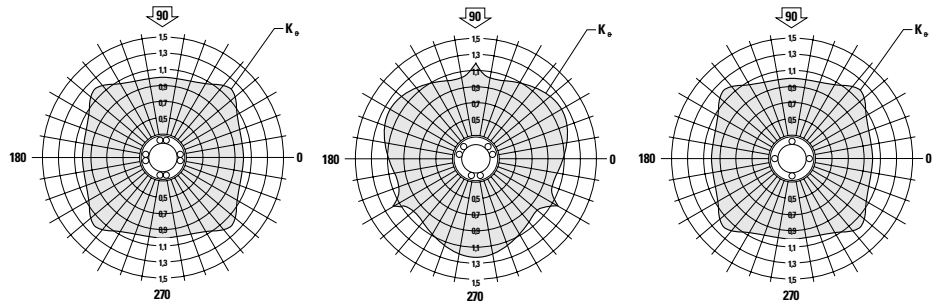

MAM16SS
MAM20SS
MAM25SS
MAM30SS

MAM12SS

MAM08SS

MultiTrac Ball Bushing Bearings

Closed Adjustable Type

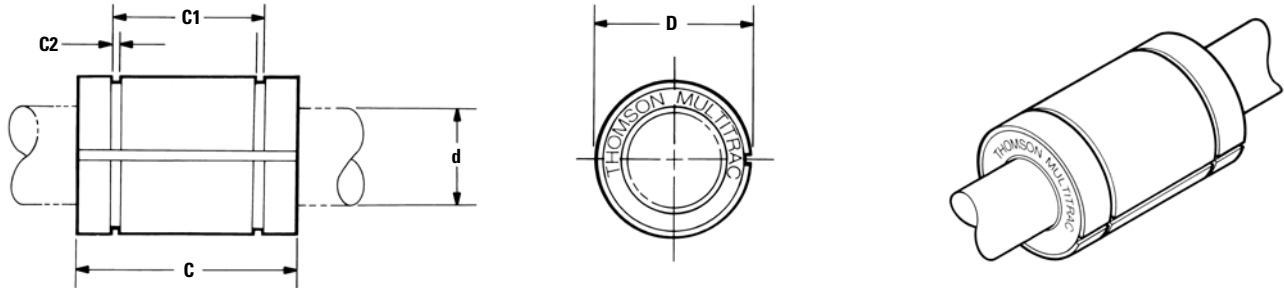

Part Number			Dimensions (mm)					Number of Ball Tracks	Mass (kg)	Dynamic Load W ⁽¹⁾⁽³⁾ (N)	Load Limit W ₀ ⁽²⁾⁽³⁾ (N)
Without Integral Wipers	With One Integral Wiper	With Two Integral Wipers	∅ d ⁽⁴⁾	∅ D	C h14	C1 H13	C2 min.				
MAM08ADJSS	MAM08ADJWSS	MAM08ADJWWSS	8	16	25	16,2	1,10	4	0,02	140	260
MAM12ADJSS	MAM12ADJWSS	MAM12ADJWWSS	12	22	32	22,6	1,30	6	0,04	280	700
MAM16ADJSS	MAM16ADJWSS	MAM16ADJWWSS	16	26	36	24,6	1,30	8	0,06	440	1040
MAM20ADJSS	MAM20ADJWSS	MAM20ADJWWSS	20	32	45	31,2	1,60	8	0,11	800	1890
MAM25ADJSS	MAM25ADJWSS	MAM25ADJWWSS	25	40	58	43,7	1,85	8	0,20	1580	4080
MAM30ADJSS	MAM30ADJWSS	MAM30ADJWWSS	30	47	68	51,7	1,85	8	0,33	1650	4640

- For rated travel life of 100 km. For longer travel lives, reduce load to $W \cdot (100/L)^{0,33}$ where L (km) is the required travel life. Do not exceed the Dynamic Load Rating for travel life of less than 100 km.
 - The load Limit is the maximum load that may be applied to a bearing and shaft. It is important to analyze the application so that peak and/or shock loads do not exceed the Load Limit.
 - The load capacities W and W₀ are valid for a resultant load applied at 90° with the ball tracks oriented as shown in the polar graphs below. If the resultant acts along another direction, the appropriate multiplicative correction factor, K_α, should be applied to W and W₀ respectively. Open type bearings have reduced load capacities when used in pull-off situations.
 - Diametral fit-up is determined by the housing diameter. See Table 2.
- NOTE: External seals and retaining rings are available. See Advanced Linear Motion Metric Components catalog, pages 42,43 for specifications.
NOTE: For additional technical data, see the Engineering Support section of the Advanced Linear Motion Metric Components catalog.

Table 2: Standard Diametral Clearances - Adjustable & Open Type

Nominal Clearances Size d (mm)	Diametral Housing Bore H6 (µm)	
	With One Wiper	With Two Wipers
8	+28	+7
12	+33	+9
16	+33	+9
20	+40	+10
25	+40	+10
30	+40	+10

For closed type bearings with LinearRace™ Shaft, h6 tolerance.

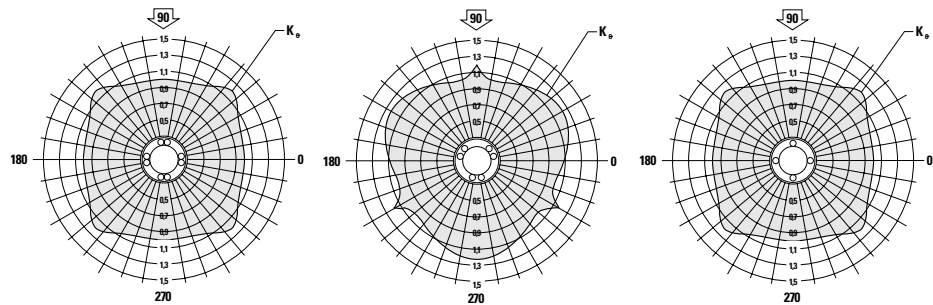

MAM16ADJSS
MAM20ADJSS
MAM25ADJSS
MAM30ADJSS

MAM12ADJSS

MAM08ADJSS

MultiTrac Ball Bushing Bearings

Open Type

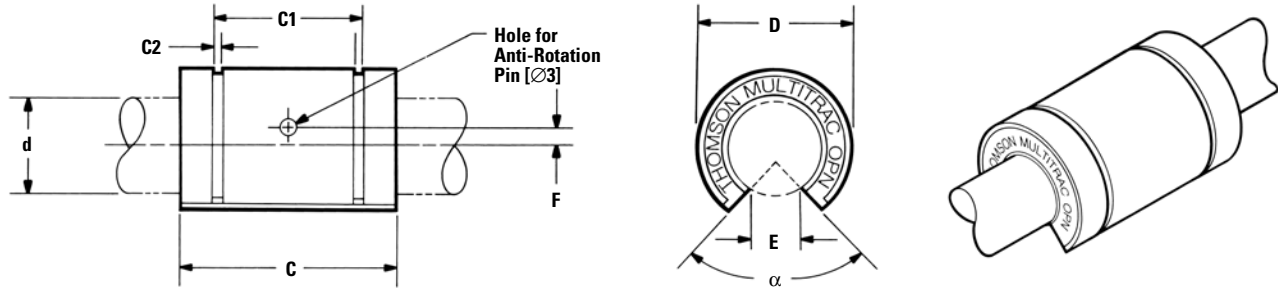

Part Number			Dimensions (mm)							Angle a (deg)	Number of Ball Tracks	Mass (kg)	Dynamic Load $W^{(1)(3)}$ (N)	Load Limit $W_0^{(2)(3)}$ (N)
Without Integral Wipers	With One Integral Wiper	With Two Integral Wipers	$\varnothing d^{(4)}$	$\varnothing D$	C h14	C1 H13	C2 min.	E	F					
MAM120PNSS	MAM120PNWSS	MAM120PNWWSS	12	22	32	22,6	1,30	7,3	1,35	120	6	0,04	354	880
MAM160PNSS	MAM160PNWSS	MAM160PNWWSS	16	26	36	24,6	1,30	10,6	0	90	8	0,06	480	1200
MAM200PNSS	MAM200PNWSS	MAM200PNWWSS	20	32	45	31,2	1,60	1,5	0	90	8	0,11	880	2176
MAM250PNSS	MAM250PNWSS	MAM250PNWWSS	25	40	58	43,7	1,85	13,9	1,50 ⁽⁵⁾	90	8	0,20	1736	4240
MAM300PNSS	MAM300PNWSS	MAM300PNWWSS	30	47	68	51,7	1,85	20,3	2,00	90	8	0,33	1808	5368

- For rated travel life of 100 km. For longer travel lives, reduce load to $W \cdot (100/L)^{0,33}$ where L (km) is the required travel life. Do not exceed the Dynamic Load Rating for travel life of less than 100 km.
- The load Limit is the maximum load that may be applied to a bearing and shaft. It is important to analyze the application so that peak and/or shock loads do not exceed the Load Limit.
- The load capacities W and W_0 are valid for a resultant load applied at 90° with the ball tracks oriented as shown in the polar graphs below. If the resultant acts along another direction, the appropriate multiplicative correction factor, K_a , should be applied to W and W_0 respectively. Open type bearings have reduced load capacities when used in pull-off situations.
- Diametral fit-up is determined by the housing diameter. See Table 2 on page 5.
- Hole for anti-rotation pin is below centerline.

NOTE: External seals and retaining rings are available. See Advanced Linear Motion Metric Components catalog, pages 42,43 for specifications.

NOTE: For additional technical data, see the Engineering Support section of the Advanced Linear Motion Metric Components catalog.

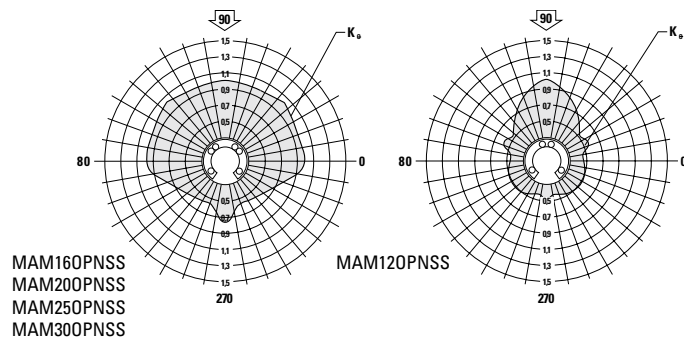

Precision Steel Ball Bushing Bearings

The basis for the performance of all Precision Steel Ball Bushing bearings is a simple but ingenious system of ball recirculation that permits almost frictionless, unlimited travel.

Replace High Friction Plain Bearings

Plain bearings cause friction, stick-slip, binding and chatter. The Precision Steel Ball Bushing bearing's patented ball recirculation virtually eliminates wear and provides a constant coefficient of friction as low as .001. This dramatic reduction in friction allows the designer to use smaller less expensive drive motors, ball screws, belts, linkages and gears.

Lasting Precision Alignment

High friction plain bearings cause wear resulting in a loss in system alignment and repeatability. Each Precision Steel Ball Bushing bearing is manufactured with high quality bearing steel that is hardened and precision ground. The rolling elements of each Ball Bushing bearing are precision ground bearing balls that recirculate freely into and out of the load zone. The balls are guided through their recirculation path by a steel retainer and hardened sleeve. The inherent non-wear characteristics of each Precision Steel Ball Bushing bearing assures maximum system accuracy and repeatability.

High Travel Speeds

Precision Steel Ball Bushing can operate at travel rates as high as 10 ft/s and accelerations as high as 450 ft/s². When replacing inefficient v-way or flat-way systems, this travel rate capability provides immediate improvements in machine efficiency and productivity.

Ease of Installation

The Precision Steel Ball Bushing bearing can be retained in a housing, internally or externally. The retaining ring groove on the outside diameter allows the bearing to be captured and retained by an external retaining ring. If internal retention is required, the Ball Bushing bearing can be installed in a housing and held in place with an internal retaining ring.

Protection from Contamination

Precision Steel Ball Bushing bearings most popular sizes are available with double acting integral wipers that keep out contamination, retain lubrication and maximize travel life.

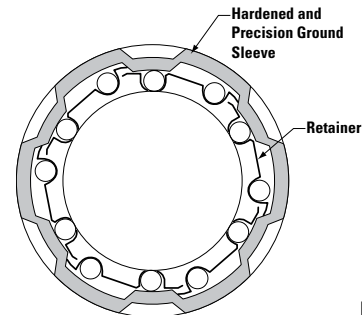

Figure 3

Precision Steel Ball Bushing Bearing Cross-section

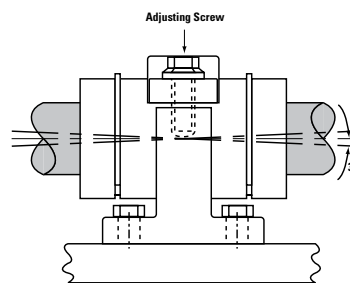
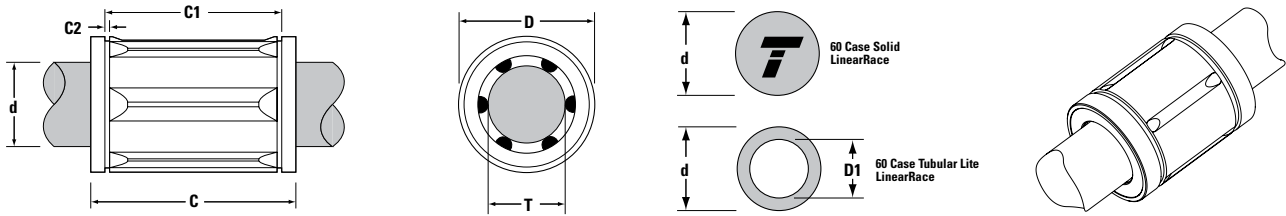

Figure 4

When the Precision Steel Ball Bushing bearing is installed in its standard Pillow Block it will self-align up to 3 degrees in all directions.

Precision Steel Ball Bushing Bearings (Closed Type) for End Supported Applications



Precision Steel Ball Bushing Bearings (Closed Type) and 60 Case LinearRace* (Dimensions in inches)

Part Number			Nominal Diameter	Length C	Distance Between Retaining Grooves C1	Retaining Ring Groove min. C2	Number of Ball Circuits	∅ D	60 Case Solid LinearRace Mass lb/in	60 Case Tubular Lite LinearRace ⁽³⁾ Mass lb/in	60 Case Tubular Lite LinearRace ⁽³⁾ ID ∅ D1
w/o Seals	with Seals	60 Case Linear Race									
A-4812-SS	—	1/4 S	.250	.750/735	.515/.499	.039	3	.5000/.4996	.01	—	—
A-61014-SS	—	3/8 S	.375	.875/.860	.640/.624	.039	4	.6250/.6246	.03	—	—
A-81420-SS	A-81420-SS-DD	1/2 S	.500	1.250/1.235	.967/.951	.046	4	.8750/.8746	.06	—	—
A-101824-SS	—	5/8 S	.625	1.500/1.485	1.108/1.092	.056	4	1.1250/1.1246	.09	—	—
A-122026-SS	A-122026-SS-DD	3/4 S	.750	1.625/1.610	1.170/1.154	.056	5	1.2500/1.2496	.13	.08	.46/.41
A-162536-SS	A-162536-SS-DD	1 S	1.000	2.250/2.235	1.759/1.741	.068	5	1.5625/1.5621	.22	.16	.62/.56

Part Number		Working Bore Diameter T	Recommended Housing Bore		60 Case LinearRace Diameter ∅ d	Precision Steel Ball Bushing Bearing/ LinearRace Fit Up ‡	Precision Steel Ball Bushing Bearing Mass lb	Dynamic Load Capacity W ^{(1) (2)} lb _f
w/o Seals	with Seals		Normal Fit	Press Fit				
A-4812-SS	—	.2500/.2495	.5005/.5000	.4995/.4990	.2490/.2485	.0015C/.0005C	.02	13
A-61014-SS	—	.3750/.3745	.6255/.6250	.6245/.6240	.3740/.3735	.0015C/.0005C	.06	26
A-81420-SS	A-81420-SS-DD	.5000/.4995	.8755/.8750	.8745/.8740	.4990/.4985	.0015C/.0005C	.08	60
A-101824-SS	—	.6250/.6245	1.1255/1.1250	1.1245/1.1240	.6240/.6235	.0015C/.0005C	.16	100
A-122026-SS	A-122026-SS-DD	.7500/.7495	1.2505/1.2500	1.2495/1.2490	.7490/.7485	.0015C/.0005C	.21	140
A-162536-SS	A-162536-SS-DD	1.0000/.9995	1.5630/1.5625	1.5620/1.5615	.9990/.9985	.0015C/.0005C	.38	250

‡ C = Clearance

(1) For rated travel life of 100 km. For longer travel lives, reduce load to $W \cdot (100/L)^{0.33}$ where L (km) is the required travel life. Do not exceed the Dynamic Load Rating for travel life of less than 100 km.

(2) The load capacities W are valid for a resultant load applied at 90° with the ball tracks oriented as shown in the polar graphs below. If the resultant acts along another direction, the appropriate multiplicative correction factor, K_{θ} , should be applied to W respectively. Open type bearings have reduced load capacities when used in pull-off situations.

(3) 60 Case Tubular Lite Linear Race available only 52100 carbon steel.

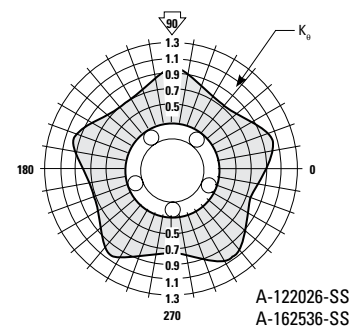
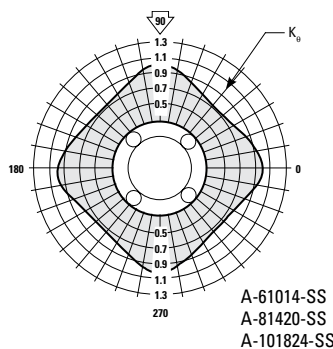
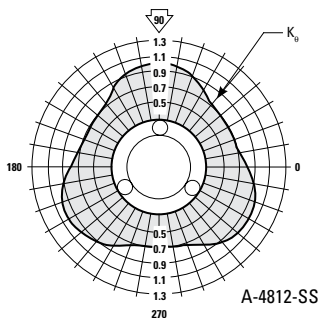

Extra Precision Steel Ball Bushing Bearings (Closed Type) for End Supported Applications

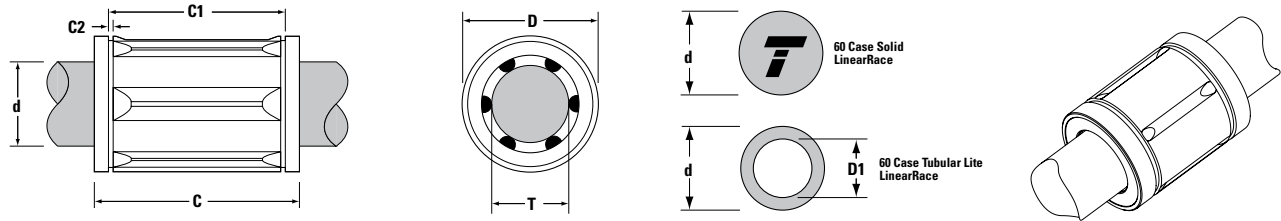

Extra Precision Steel Ball Bushing Bearings (Closed Type) and 60 Case LinearRace (Dimensions in inches)

Part Number		60 Case Linear Race	Nominal Diameter	Length C	Distance Between Retaining Grooves C1	Retaining Ring Groove min. C2	Number of Ball Circuits	∅ D	60 Case Solid LinearRace Mass lb/in	60 Case Tubular Lite LinearRace Mass lb/in	60 Case Tubular Lite LinearRace ID ∅ D1
w/o Wipers	with Wipers										
XA-4812-SS	–	1/4 L	.250	.750/735	.515/.499	.039	3	.5000/.4996	.01	–	–
XA-61014-SS	–	3/8 L	.375	.875/.860	.640/.624	.039	4	.6250/.6246	.03	–	–
XA-81420-SS	XA-81420-SS-DD	1/2 L	.500	1.250/1.235	.967/.951	.046	4	.8750/.8746	.06	–	–
XA-101824-SS	–	5/8 L	.625	1.500/1.485	1.108/1.092	0.56	4	1.1250/1.1246	.09	–	–
XA-122026-SS	XA-122026-SS-DD	3/4 L	.750	1.625/1.610	1.170/1.154	.056	5	1.2500/1.2496	.13	.08	.46/.41
XA-162536-SS	XA-162536-SS-DD	1 L	1.000	2.250/2.235	1.759/1.741	0.68	5	1.5625/1.5621	.22	.16	.62/.56

Part Number		Working Bore Diameter T	Recommended Housing Bore		60 Case LinearRace Diameter ∅ d	Precision Steel Ball Bushing Bearing/ LinearRace Fit Up ‡	Precision Steel Ball Bushing Bearing Mass lb	Dynamic Load Capacity W ₁ ^{(1) (2)} lb ₁
w/o Seals	with Seals		Normal Fit	Press Fit				
XA-4812-SS	–	.2500/.2497	.5005/.5000	Not Normally Recommended	.2495/.2490	.0010C/.0002C	.02	13
XA-61014-SS	–	.3750/.3747	.6255/.6250		.3745/.3740	.0010C/.0002C	.06	26
XA-81420-SS	XA-81420-SS-DD	.5000/.4997	.8755/.8750		.4995/.4990	.0010C/.0002C	.08	60
XA-101824-SS	–	.6250/.6247	1.1255/1.1250		.6245/.6240	.0010C/.0002C	.16	100
XA-122026-SS	XA-122026-SS-DD	.7500/.7497	1.2505/1.2500		.7490/.7485	.0010C/.0002C	.21	140
XA-162536-SS	XA-162536-SS-DD	1.0000/.9997	1.5630/1.5625		.9995/.9990	.0010C/.0002C	.38	250

‡ C = Clearance

(1) For rated travel life of 100 km. For longer travel lives, reduce load to $W \cdot (100/L)^{0.33}$ where L (km) is the required travel life. Do not exceed the Dynamic Load Rating for travel life of less than 100 km.

(2) The load capacities W are valid for a resultant load applied at 90° with the ball tracks oriented as shown in the polar graphs below. If the resultant acts along another direction, the appropriate multiplicative correction factor, K_{θ} , should be applied to W respectively. Open type bearings have reduced load capacities when used in pull-off situations.

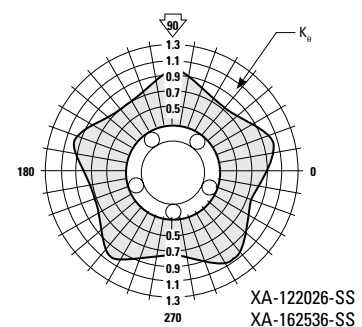
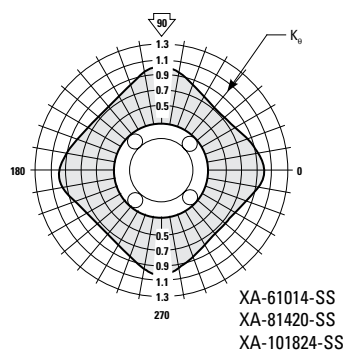
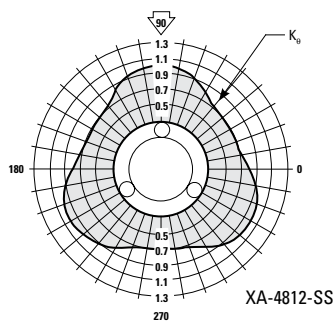

Adjustable Precision Steel Ball Bushing Bearings (Closed Type) for End Supported Applications

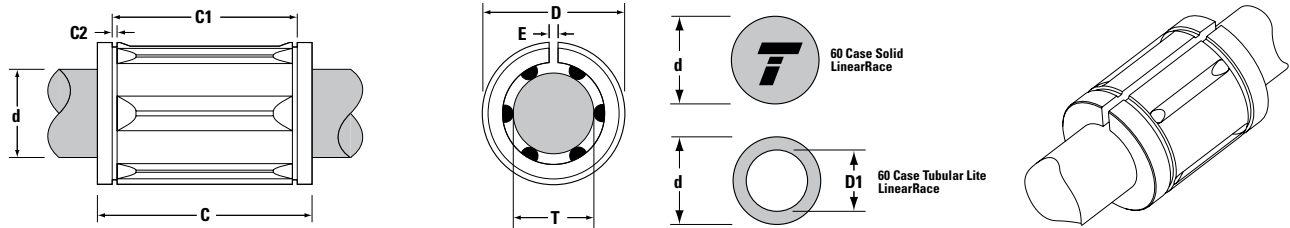

Adjustable Precision Steel Ball Bushing Bearings (Closed Type) and 60 Case LinearRace (Dimensions in inches)

Part Number		Nominal Diameter	Length C	Distance Between Retaining Grooves C1	Retaining Ring Groove min. C2	Min. Slot Width E	Number of Ball Circuits	60 Case LinearRace Minimum Depth of Hardness	60 Case Solid LinearRace Mass lb/in	60 Case Tubular Lite LinearRace Mass lb/in	60 Case Tubular Lite LinearRace ID \varnothing D1
Precision Steel Ball Bushing Bearing	60 Case Linear Race										
ADJ-81420-SS	1/2 L	.500	1.250/1.235	.967/.951	.046	.06	4	.04	.06	—	—
ADJ-101824-SS	5/8 L	.625	1.500/1.485	1.108/1.092	0.56	.09	4	.04	.09	—	—
ADJ-122026-SS	3/4 L	.750	1.625/1.610	1.170/1.154	.056	.09	5	.06	.13	.08	.46/.41
ADJ-162536-SS	1 L	1.000	2.250/2.235	1.759/1.741	0.68	.09	5	.08	.22	.16	.62/.56

Part Number	Working Bore Diameter T	Recommended Housing Bore Diameter \varnothing D	60 Case LinearRace Diameter \varnothing d	Precision Steel Ball Bushing Bearing Mass lb	Dynamic Load Capacity W ^{(1) (2)} lb _r
		Normal Fit			
ADJ-81420-SS	.5000/.4995	.8755/.8750	.4995/.4990	.08	60
ADJ-101824-SS	.6250/.6245	1.1255/1.1250	.6245/.6240	.16	100
ADJ-122026-SS	.7500/.7495	1.2505/1.2500	.7490/.7485	.21	140
ADJ-162536-SS	1.0000/.9995	1.5630/1.5625	.9995/.9990	.38	250

- (1) For rated travel life of 100 km. For longer travel lives, reduce load to $W \cdot (100/L)^{0.33}$ where L (km) is the required travel life. Do not exceed the Dynamic Load Rating for travel life of less than 100 km.
- (2) The load capacities W are valid for a resultant load applied at 90° with the ball tracks oriented as shown in the polar graphs below. If the resultant acts along another direction, the appropriate multiplicative correction factor, K_0 , should be applied to W respectively. Open type bearings have reduced load capacities when used in pull-off situations.

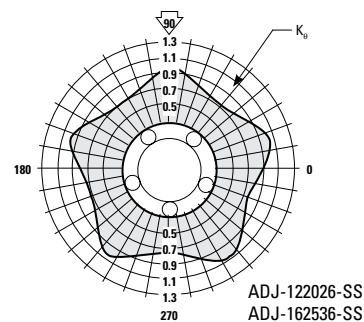
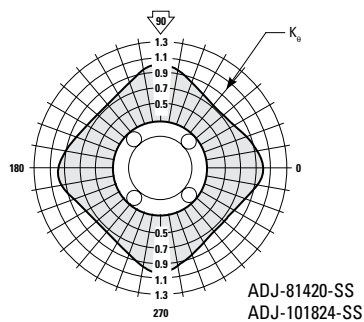

Precision Steel Ball Bushing Bearings (Open Type) for Continuously Supported Applications

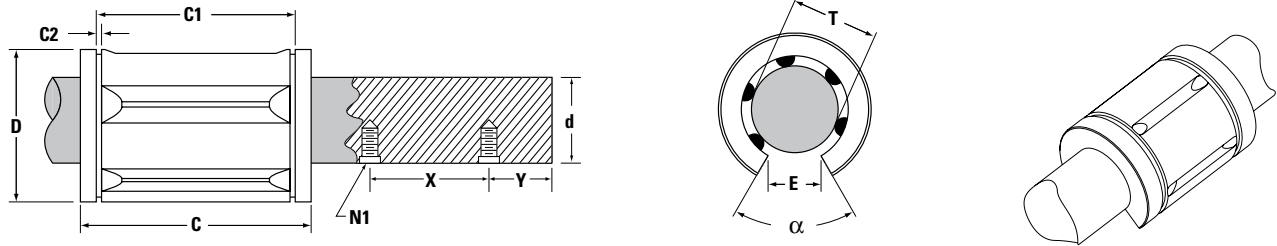

Precision Steel Ball Bushing Bearings (Open Type) and 60 Case LinearRace (Dimensions in inches)

Part Number		Nom. Dia.	Length C	Distance Between Retaining Rings C1	Ret. Ring Groove min. C2	60 Case LinearRace Minimum Depth of Hardness	60 Case Solid LinearRace Mass lb/in	60 Case LinearRace Mounting Holes		
Precision Steel Ball Bushing Bearing	60 Case Linear Race							X	Y	N1
OPN-81420-SS	1/2 L PD	.500	1.250/1.235	.967/.951	.046	.04	.06	4	2	#6-32
OPN-101824-SS	5/8 L PD	.625	1.500/1.485	1.108/1.092	.056	.04	.09	4	2	#8-32
OPN-122026-SS	3/4 L PD	.750	1.625/1.610	1.170/1.154	.056	.06	.13	6	3	#10-32
OPN-162536-SS	1 L PD	1.000	2.250/2.235	1.759/1.741	.068	.08	.22	6	3	1/4-20

Part Number	Working Bore Diameter T	Recommended Housing Bore Before Adjustment $\varnothing D$	60 Case LinearRace Diameter $\varnothing d$	Minimum Slot Width E	Angle deg α	Number of Ball Circuits	Ball Bushing Bearing Mass lb	Dynamic Load Capacity $W^{(1)(2)}$ lb _f
OPN-81420-SS	.5005/.4995	.8760/.8740	.4995/.4990	.31	50	3	.07	40
OPN-101824-SS	.6255/.6245	1.1260/1.1240	.6245/.6240	.38	60	3	.11	75
OPN-122026-SS	.7505/.7495	1.2510/1.2490	.7495/.7490	.44	60	4	.17	100
OPN-162536-SS	1.0005/.9995	1.5635/1.5615	.9995/.9990	.56	60	4	.32	170

(1) For rated travel life of 100 km. For longer travel lives, reduce load to $W \cdot (100/L)^{0.33}$ where L (km) is the required travel life. Do not exceed the Dynamic Load Rating for travel life of less than 100 km.

(2) The load capacities W are valid for a resultant load applied at 90° with the ball tracks oriented as shown in the polar graphs below. If the resultant acts along another direction, the appropriate multiplicative correction factor, K_{θ} , should be applied to W respectively. Open type bearings have reduced load capacities when used in pull-off situations.

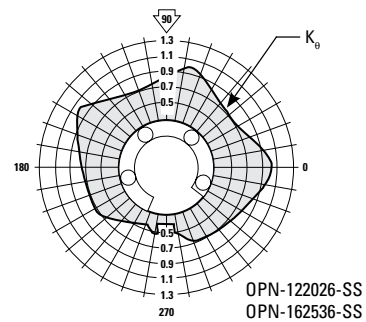
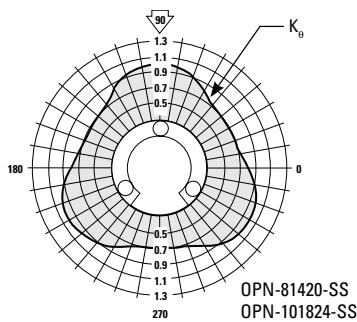

USA, Canada and Mexico

Danaher Motion
203A West Rock Road
Radford, VA 24141 USA
Phone: 1-540-633-3400
Fax: 1-540-639-4162
E-mail: DMAC@danahermotion.com

United Kingdom

Danaher Motion
Chartmoor Road, Chartwell Business Park
Leighton Buzzard, Bedfordshire
LU7 4WG; United Kingdom
Phone: +44 (0)1525 243 243
Fax: +44 (0)1525 243 244
E-mail: sales.uk@danahermotion.com

Germany

Danaher Motion GmbH
Sales Office North
Wacholderstr. 40-42
40489 Düsseldorf
Germany
Phone: +49 (0) 203 9979 214
Fax: +49 (0) 203 9979 3214
E-mail: iris.tolusch@danahermotion.com

Danaher Motion GmbH
Sales Office South West
Brückenfeldstraße 26/1
75015 Bretten
Germany
Phone: +49 (0) 7252 96462 10
Fax: +49 (0) 7252 96462 69
E-mail: kerstin.mueller@danahermotion.com

Danaher Motion GmbH
Sales Office South East
Kiesgräble 7
89129 Langenau
Germany
Phone: +49 (0) 7471 62 23 23
Fax: +49 (0) 7471 62 23 26
E-mail: ursula.koschak@danahermotion.com

France

Danaher Motion
C.P 80018
12, Rue Antoine Becquerel – Z.I. Sud
72026 Le Mans Cedex 2
France
Phone: +33 (0) 243 50 03 30
Fax: +33 (0) 243 50 03 39
E-mail: sales.france@danahermotion.com

Italy

Danaher Motion srl
Largo Brughetti
20030 Bovisio Masciago
Italy
Phone: +39 0362 594260
Fax: +39 0362 594263
E-mail: info@danahermotion.it

Sweden

Danaher Motion
Box 9053
291 09 Kristianstad
Sweden
Phone: +46 (0) 44-24 67 00
Fax: +46 (0) 44-24 40 85
E-mail: sales.scandinavia@danahermotion.com

Switzerland

Danaher Motion SA
La Pierreire 2
1029 Villars-Ste-Croix
Switzerland
Phone: +41 (0) 21 631 33 33
Fax: +41 (0) 21 636 05 09
E-mail: info@danaher-motion.ch

China

Danaher Motion
Rm 2205, Scitech Tower
22 Jianguomen Wai Street
Beijing, China, 100004
Phone: +86 10 6515 0260
Fax: +86 10 6515 0263
E-mail: chinainfo@danahermotion.com.cn

Japan

Danaher Motion Japan
2F, Tokyu Reit Hatchobori Bldg,
2-7-1 Hatchobori Chuo-ku,
Tokyo 104-0032 Japan
Phone: +81-3-6222-1051
Fax: +81-3-6222-1055
E-mail: info@danahermotion.co.jp

Asia Pacific

Danaher Motion (HK) Ltd
Unit A, 16 Floor, 169 Electric Road
Manulife Tower, North Point
Hong Kong
Phone: +852 2503 6581
Fax: +852 2571 8585
E-mail: victor.lim@danahermotion.com