



Thomas Flexible Disc Couplings Catalog

(Inch)

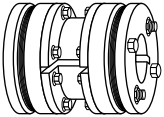
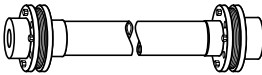
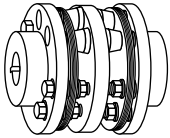
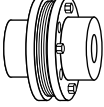
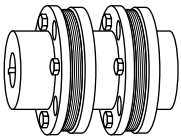
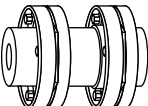
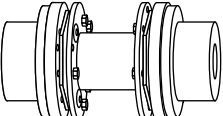
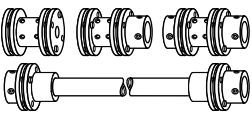
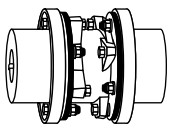
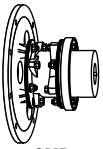
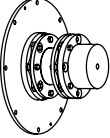
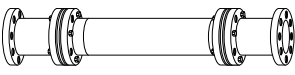

DESCRIPTION	PAGE
Rexnord Thomas Coupling Application Guide	3
Rexnord Thomas Flexible Disc Couplings Overview	4
Rexnord Thomas Coupling Nomenclature	5
Service Factors	6
Ordering Instructions	7
REXNORD THOMAS COUPLINGS	
Series 54RDG Close-Coupled Coupling	8
Series 54RD Close-Coupled Coupling	9
Types DBZ, DBZ-A, DBZ-B Close-Coupled Couplings	10
Series XTSR52 Spacer Type Coupling with Optional Adapter	11
Series XTSR71 Spacer Type Coupling with Adapters	14
Tollok TLK 603 External Shrink Disc Standard Version	17
Series XTSRSL52 Spacer Type Coupling with Optional Adapter	18
Series XTSRSL71 Spacer Type Coupling with Adapter	21
Series XTSRGA Spacer Type Coupling	24
Series XTSRS Single Flex Type Coupling with Optional Adapter	25
Type AMR Spacer Coupling	28
Type CMR Flywheel Adapter Coupling	30
Series 44 Flywheel Adapter Type Spacer Coupling	32
Style CB & CBC Miniature Couplings	35
Style CE & CS Miniature Couplings	36
REXNORD THOMAS SUPPORTED PRODUCTS	
Series 63 High Performance Couplings	38
Series 52 Spacer Type Couplings	39
Series 71 Spacer Type Couplings	40
Series 71 4-, 6- & 8-Bolt Spacer Type Couplings	41
Type SN-GA Floating Shaft Coupling	42
Types SN, SF, SV Floating Shaft Couplings	43
Types SN, SF, SV Floating Shaft Couplings	44
Type SN Single Flexing Disc Coupling	46
Engineering Data — All Rexnord Couplings	47
Standard Keyway Dimensions – Tolerances	48
Customized Flexible Disc Couplings Designs	49

Coupling Type	Typical Applications	Coupling Type	Typical Applications
 <p>Series 54RDG</p>	Close-coupled applications. Suitable as replacement for gear and grid couplings.	 <p>Series XTSSL52, XTSSL71</p>	<p>XTSSL52: Pumps, generators, fans (mine ventilating, forced and induced draft), paper mills drives, line shafts, pumps, and printing machines.</p> <p>XTSSL71: Turbines, pumps, compressors, test stands, generators, generators, and engine drives.</p>
 <p>DBZ, DBZ-A, DBZ-B</p>	Mixers, compressors, agitators, blowers and fans, centrifugal pumps, conveyors.	 <p>Series XTSSRS</p>	Accommodates angular misalignment only. May be used with an intermediate solid shaft to accommodate long spans, three bearing applications where radial load is supported by the coupling, such as single bearing generators, V-belt sheaves, etc.
 <p>Series XTSSR52</p>	Pumps and compressors (centrifugal, rotary, lobe and axial), speed increasers, fans, dynamometers.	 <p>Series 63</p>	Turbines, pumps, compressors, test stands, generators, speed increasers.
 <p>Series XTSSR71</p>	Pumps and compressors with popular shaft separation standards, blowers, fans, speed increasers.	 <p>Miniature Couplings</p>	Tachometers, encoders, switches, ball screws, test stands, pumps, compressors, centrifuges, theodolites, sonar, radar, scales, carburetors.
 <p>AMR</p>	Reciprocating pumps and compressors, fan drives, blowers, heavy-duty industrial drives, crushers, extruders, hoists, dredges, generators, chippers, calenders, mill drives, conveyors.		
 <p>CMR</p>	Engine drivers, reciprocating pumps and compressors, heavy-duty industrial drives where flywheel mounting is required.		
 <p>Series 44</p>	Engine drivers, reciprocating pumps and compressors, heavy-duty industrial drives where flywheel mounting is required.		
 <p>Series XTSSRGA</p>	Pulp and paper machines, line shafts, pelletizers, crushers and mill drives. Replacing long span gear couplings, bolting to existing rigid hubs.		

A flexible coupling is a device used to connect the ends of two shafts, transmit torque, and at the same time, accommodate slight misalignments which develop in service.

The primary functions of all flexible couplings are:

1. To transmit power from one shaft to another, efficiently and effectively.
2. To accommodate slight shaft misalignments which develop in service.

The secondary functions of flexible couplings are:

1. Protect connected equipment:
 - a. Absorb shock, vibration and pulsations.
 - b. Decrease cross load on bearings.
 - c. Accept load reversals.
 - d. Minimize backlash.

2. Minimize "installation" and "maintenance" difficulties. Shafts become misaligned during operation because of settling foundations, the effects of heat, vibration, etc. These misalignments take place in the form of angular misalignment, parallel misalignment or axial movement of the shafts; therefore, to get full service life from any flexible coupling, it is necessary to:
 - a. Assure proper shaft alignment during initial installation.
 - b. Occasionally check for and correct shaft misalignments during operation.

Misalignment Overview

Misaligned shafts not properly coupled are subject to severe stresses that damage bearings and seals. Any or all of the misalignments shown in the above diagrams are present in all connected drives; therefore, it is imperative that flexible couplings be used to avoid costly damage to your equipment.

Initial alignment of machinery is one of the most critical factors affecting coupling performance and reliability. Each particular style of coupling has its own misalignment capabilities. The installation and alignment instructions outline the initial alignment requirements. These initial values are approximately one-third of the total coupling misalignment capacity. This means that the coupling has ample reserve to compensate for operational misalignments which develop as a result of bearing wear, foundation settling, thermal growth, pipe strain, etc. However, the closer the initial alignment, the

more reserve margin a coupling has to compensate for misalignments during the life of the machine. A coupling that operates with large amounts of misalignment will have a limited life, while a coupling operating within capacity will have infinite life.

The customer and coupling manufacturer must mutually select the correct size and type coupling for the application. Good service life will then become a reality if proper installation and alignment procedures are followed.

The following pages show basic coupling arrangements and load classifications based on years of experience in coupling applications in all phases of power transmission. Any unusual operating or misalignment conditions should be referred to Rexnord to assure proper selection of size and type of coupling.

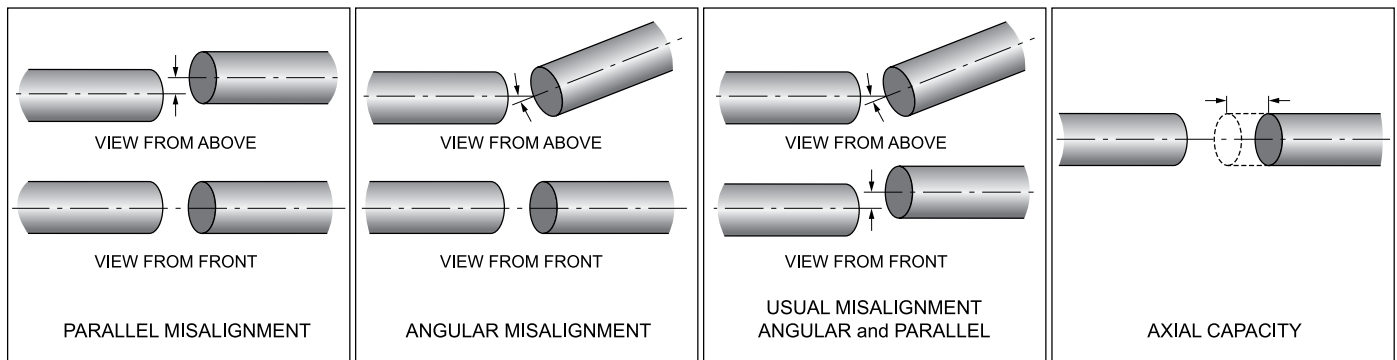

Maximum RPM and Balance Recommendations

Rexnord has developed recommendations for coupling balancing based on AGMA 9000-D11 and the inherent balance level of the various couplings shown in this catalog. These are shown on the data sheets as follows:

Max. RPM Not Balanced

This is the maximum operating speed where the coupling will operate under normal conditions, and not create unacceptable vibration due to coupling unbalance. This is based on many years of operating experience on a wide variety of drive systems.

Max. RPM Balanced

This is the maximum operating speed where the coupling, after balancing, will still be compatible with the typical drive system. Consult Rexnord for speed requirements in excess of this value; special designs or manufacturing procedures may be required.

Certain coupling types are not suitable for dynamic balancing, and should not be used if balancing is required. These types are AMR, CMR, BMR and ST.

Series 63 and THP couplings are always furnished dynamically balanced in accordance with the requirements of the application.

CAUTION: All rotating power transmission products are potentially dangerous and must be properly guarded. Never operate coupling without an OSHA-approved guard.

The following procedure can be used to select disc couplings for most applications.

For applications involving other than normal loading in design, special considerations must be given to coupling selection. Rexnord application engineers are readily available for selection, advice and assistance.

1. Select coupling type.

Refer to page 3 and select the type of coupling to suit your application. If an application requires a special purpose coupling, refer application details to the local Rexnord Representative.

2. Calculate operating torque of application.

- a. Use the following formula to calculate operating torque of application:

$$i. \text{ Torque (lb-in) } = \frac{\text{Driver Horsepower} \times 63025}{\text{Operating Speed}}$$

3. Determine service factor.

- a. Find application in table on page 6; use the service factor value assigned to that application.

- b. Note: if application not listed, see Load Classification Table on page 6.

- c. Note: The service factor table considers the driven equipment only and assumes a normal electric or turbine driver. For prime movers of the reciprocating type (engines, etc) use the engine drive service factor adder on page 6 to the selected service factor.

4. Multiply operating torque by the selected service factor to determine minimum required torque rating of coupling.

5. Find coupling in the coupling type section of catalog that meets the minimum required torque rating.

6. Verify that the selected coupling will accommodate the shaft sizes or flywheel if engine mount, of driving and driven equipment. Shaft diameters should be equal or less than published maximum bore of selected coupling.

- a. If coupling will not accommodate shaft sizes, select the next largest size that will accommodate shaft sizes.

7. Verify coupling selected can accommodate operating speed of application.

8. Check limiting data.

- a. Other data in coupling type section of catalog can be used to verify that selected coupling will work in application. Additional data can help verify application envelope of space, weight and WR² considerations.

IMPORTANT NOTE:

The coupling selection criteria is intended for the determination of the coupling and style only. It is also recommended that the system be analyzed for torsional and lateral stability using the specific mass elastic data available from Rexnord. The analysis is the responsibility of the user since the coupling is only a single component in the system.

Rexnord Thomas Coupling Nomenclature

Use the following nomenclature guide to identify and order Thomas Disc Couplings.

Coupling Size	Type/Series	Modifications	Distance Between Shaft Ends ("C" Length)	Hub Bore
2506	XTSR71	B	9.00	3.250 x 2.50
	XTSR71	B = Balanced	9.00"	110 mm x Taper
	XTSR52	ES = Engineered Special	N/A	1.00 x 2.00
	DBZ	L = Long Hub	130 mm	Taper x 3.00
	AMR	C = Special Coating (defined on drawings)		etc.
	CMR	D = Special Disc Pack Material (defined on drawings)		
	SR54RDG	R = Retrofit assembly (XTSR71 with special adapters to bolt up to John Crane or Thomas adapter hubs)		
	XTSRLS52			
	XTSRLS71			
	XTSRGA			
	SR63			
	SR71			
	SR71-8			
	SR52			







Typical Service Factors – Motor And Turbine Driven Equipment*

Application	Service Factor	Application	Service Factor	Application	Service Factor
AGITATORS		Bottling1.5		Presses2.0	
Pure Liquids.....1.0		GENERATORS		Reel1.5	
Variable Density1.5		Non-Welding.....1.5		Stock Chests1.5	
ALTERNATOR	1.5	Welding3.0		Suction Roll2.0	
BLOWERS		HAMMER MILLS	3.0	Washers and Thickeners.....1.5	
Centrifugal1.0		LUMBER INDUSTRY		Winders.....1.5	
Lobe1.5		Barkers - Drum Type2.5		PRINTING PRESSES	1.5
Vane1.5		Edger Feed2.0		PULLERS	
BRIQUETTER MACHINES	2.0	Live Rolls2.0		Barge Haul2.0	
CAN FILLING MACHINES	1.0	Log Haul - Incline2.0		PUMPS	
CANE KNIVES	2.0	Log Haul - Well Type.....2.0		Centrifugal	
CAR DUMPERS	2.5	Off Bearing Rolls2.0		General Duty (Liquid).....1.0	
CAR PULLERS	1.5	Planer Feed Chains2.0		Boiler Feed1.5	
CLAY WORKING MACHINERY	2.0	Planer Floor Chains2.0		Slurry (Sewage, etc.).....1.5	
COMPRESSORS		Planer Tilting Hoist2.0		Dredge2.0	
Centrifugal1.0		Slab Conveyor1.5		Reciprocating	
Lobe, Vane, Screw.....1.5		Sorting Table.....1.5		Double Acting2.0	
Reciprocating - Multi-Cylinder.....Consult Rexnord		Trimmer Feed2.0		Single Acting	
Axial.....1.0		MACHINE TOOLS		1 or 2 Cylinders2.5	
CONVEYORS - uniformly loaded or fed1.5		Bending Roll2.0		3 or more Cylinders2.0	
CONVEYORS - heavy duty - not uniformly fed2.5		Plate Planer1.5		Rotary - Gear, Lobe, Vane1.5	
CRANES AND HOISTS	2.0	Punch Press - Gear Driven.....2.0		RUBBER INDUSTRY	
CRUSHERS	3.0	Tapping Machines.....2.5		Mixer - Banbury.....3.0	
DREDGES		Other Machine Tools		Rubber Calendar2.0	
Cable Reels2.0		Main Drives.....1.5		Rubber Mill (2 or more)2.5	
Conveyors.....1.5		Auxiliary Drives.....1.5		Sheeter.....2.0	
Cutter Head Drives2.5		METAL MILLS		Tire Building Machines2.5	
Jig Drives2.5		Draw Bench - Carriage2.5		Tire & Tube Press Openers.....1.0	
Maneuvering Winches.....2.0		Draw Bench - Main Drive.....2.5		Tubers and Strainers2.0	
Pumps.....2.0		Forming Machines2.5		SCREENS	
Screen Drives.....2.0		Stilters.....2.0		Air Washing1.0	
Stackers2.0		Table Conveyors		Rotary - Stone or Gravel.....1.5	
Utility Winches1.5		Non-Reversing2.5		Traveling Water Intake1.5	
ELEVATORS		Reversing3.0		Vibratory2.5	
Bucket2.0		Wire Drawing & Flattening Machine.....2.0		SEWAGE DISPOSAL EQUIPMENT	1.5
Centrifugal Discharge.....1.5		Wire Winding Machine.....2.0		SEWAGE TREATMENT PUMPS	1.5
Escalators1.5		MILLS, ROTARY TYPE		TEXTILE INDUSTRY	
Freight.....2.0		Ball.....2.5		Batchers1.5	
Gravily Discharge.....1.5		Cement Kilns.....2.0		Calenders.....2.0	
EXTRUDERS		Dryers & Coolers.....2.0		Card Machines1.5	
Plastic2.0		Kilns.....2.0		Cloth Finishing Machines	
Metal.....2.5		Pebble.....2.0		(washers, pads, tenters)	
FANS		Rod2.0		(dryers, calenders, etc.).....1.5	
Centrifugal		Tumbling Barrels.....2.0		Dry Cans2.0	
Forced Draft (Hostile Environment)1.5		MIXERS		Dryers1.5	
Induced Draft (Hostile Environment)1.5		Concrete Mixers.....2.0		Dyeing Machinery.....1.5	
Axial		Drum Type.....2.0		Looms1.5	
Forced Draft (Hostile Environment)1.5		OIL INDUSTRY		Mangles1.5	
Induced Draft (Hostile Environment)1.5		Chillers1.5		Nappers.....1.5	
Mine Ventilation2.5		Oil Well Pumping.....2.0		Soapers.....1.5	
Cooling Towers1.5		Paraffin Filter Press.....2.0		Spinners.....1.5	
Light Duty Blower & Fans1.0		Rotary Kilns2.0		Tenter Frames.....1.5	
FEEDERS		PAPER MILLS		Winders (Other than Batchers)1.5	
Light Duty1.5		Barker Auxiliaries, Hydraulic2.5		WINDLASS	2.0
Heavy Duty.....2.5		Barker, Mechanical.....2.5		WOODWORKING MACHINERY	1.5
FOOD INDUSTRY		Barking Drum (Spur Gear Only)2.5			
Beet Slicer2.0		Beater & Pulper.....2.0			
Cereal Cooker1.5		Bleacher1.0			
Dough Mixer.....2.0		Calenders.....2.0			
Meat Grinders2.0		Converting Machines, except			
Can Filling Machine.....1.0		Cutters, Platers.....1.5			
		Couch2.0			
		Cutters, Platers.....2.0			
		Cylinders.....2.0			
		Dryers2.0			
		Felt Stretcher1.5			
		Felt Whipper2.0			
		Jordans2.0			
		Log Haul2.0			

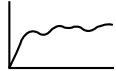
*Service Factors in this table are for driven equipment based on smooth prime movers such as electric motors and turbines. For reciprocating prime movers, such as diesel or gas engines, add the following to the Service Factor:

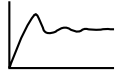
For 8 or more cylinders, add 0.5.
 For 6 cylinders, add 1.0.
 For 4 cylinders, add 1.5.
 For less than 4 cylinders, consult Rexnord.

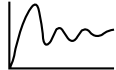
Service Factors – Service Factors are a means of classifying different equipment and applications into various load classifications. Due to variations in application of equipment, service factors are used to adjust equipment ratings to accommodate for variable loading conditions.

	Load Classifications	Service Factors		Load Classifications	Service Factors
	Continuous service and running loads vary only slightly.	1.0		For shock loading and substantial torque variations.	2.5
	Torque loading varies during operation of the equipment.	1.5		For heavy shock loading or light reversing drives.	3.0
	Torque loading varies during operation, frequent stop/start cycles are encountered.	2.0		Reversing torque loads do not necessarily mean reversal of rotation. Depending upon severity of torque reversal, such loads must be classified between "medium" and "extreme."	Consult Rexnord

Complete steps 1 through 6 below. See page 37 for types of fits and shaft diameters.

1. Determine quantity.
2. Determine coupling size and type.
3. Determine bore sizes. Couplings will be bored in accordance with ANSI/AGMA 9002-B04. The type of bore fit normally supplied by Rexnord is listed below.

Bore Specifications

DBZ	Straight Bore – Clearance fit – stocked Straight Bore – Interference fit on bore-to-order sizes ① Taper Bore – To customer specification
AMR, CMR, SN, SF, SV, 52, 54RDG, 54RD, 71, 71-8, XTSR52, XTSR71	Straight Bore – Interference fit on all bores ① Taper Bore – To customer specification
Series 63	All bores per customer specification
Miniatures	See pages 30-32.

① Unless specified otherwise by customer.

NOTE: Rexnord recommends an interference fit be used whenever possible.

4. Determine keyway and set screw sizes (if non-standard).
5. Determine dynamic balancing (if required).
6. Additional data (where applicable).
 - a. Disc pack material (if other than Tomaloy).
 - b. Free or interference fit on shafts (if shaft diameters are given).
 - c. Complete details on tapered bore requirements, see supplemental taper bore information section below.
 - d. On DBZ-A Couplings:
 1. Identify bore of standard hub and bore of extended hub.
 - e. On SN, SF, and SV Couplings:
 1. Corrosion resistance class
 2. "L" dimension
 3. Dynamic balancing if required
 4. Sketch of stub shaft (SF only) if non-standard
 5. On SV, identify bore of upper hub and lower hub
 6. Operating speed required
 - f. On CMR Couplings:
 1. Adapter:
 - (a) Outside diameter
 - (b) Bolt circle diameter
 - (c) Bolt hole diameter
 - (d) Number of bolts and spacing

Ordering Information – Tapered Bores

Information Required

1. Drawing of hub showing complete bore and keyway details.
- OR -
2. Drawing of shaft with dimensions shown below, allowing Rexnord to bore hubs to suit.

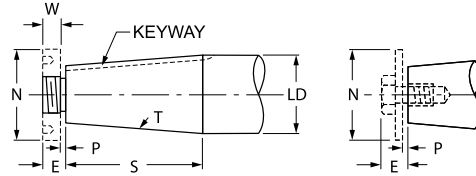

(LD) Large diameter, specify in decimals.

(S): Length of taper; measure parallel to shaft centerline.

(T): Taper per foot; difference in diameter in one foot length.

(P): Clearance space for drawing hub up on tapered shaft. Usually 1/8 in. or 1/4 in., depending on shaft size and taper.

Keyway: Width, depth.

NOTE: Specify if keyway is parallel to taper or if parallel to shaft center line. Specify depth at larger diameter of taper if keyway is parallel to shaft center line.

Supplemental Taper Bore Information

With connected equipment in fixed position, the following additional information is necessary:

Dimensions "V" and "X" must be given when one or both connected machines are fixed on their bases. Advise if dimension "X" is fixed, or if variable between what limits.

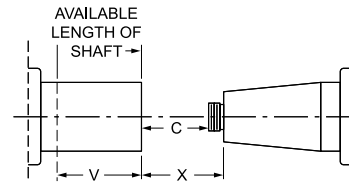

A fixed "X" dimension may require altered or special coupling hubs. Often the straight bored hub can be positioned on its shaft allowing the use of a standard coupling. See illustrations below.

Consult AGMA Standard 9002-A86 "Taper Bores for Flexible Couplings" for new applications.

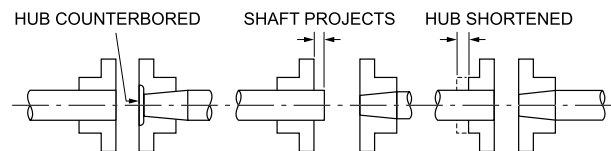

Series 54RDG couplings are reduced diameter gear and grid replacement couplings. Applications include any situation where the overall shaft-to-shaft spacing is minimal. The center member of the 54RDG is split axially, which permits maintenance of the couplings without moving the hubs or the connected equipment. Center member is piloted into the adapter providing high-speed potential at high-torque density.

Construction

- Hubs and Center members: Carbon steel
- Bolts: Alloy steel
- Disc Packs: Stainless steel
- Coatings Available: Consult Rexnord
- Other disc pack materials such as Tomaloy, Monel and Inconel are available; please consult Rexnord.
- Misalignment: 1/8° per disc pack

When specified, Series 54RDG couplings meet all requirements of API 610 or API 671. If application requires API specification, please consult Rexnord.

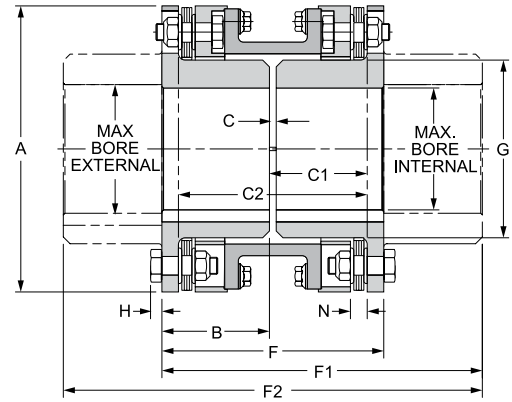

General Dimensions (in)

Size	Max. Bore Internal	Max. Bore* External	A	B	C	C1**	F	F1**	H	N	G	C2***	F2***
125	1.188	1.375	3.81	1.88	0.12	1.75	3.875	4.94	0.17	0.27	1.75	3.38	6.00
162	1.625	1.875	4.47	1.88	0.12	1.77	3.875	5.40	0.17	0.29	2.34	3.42	6.92
200	2.250	2.250	5.56	2.12	0.12	1.96	4.375	6.14	0.22	0.36	3.25	3.80	7.92
225	2.375	2.625	5.88	2.19	0.12	2.03	4.499	6.84	0.22	0.36	3.50	3.94	9.18
262	2.750	3.125	6.88	2.59	0.19	2.42	5.370	7.89	0.25	0.47	4.12	4.65	10.41
312	3.375	3.625	7.84	2.84	0.19	2.62	5.870	8.84	0.30	0.50	5.00	5.05	11.81
350	3.750	4.000	8.78	3.28	0.25	3.06	6.810	10.09	0.22	0.54	5.50	5.87	13.37
375	4.188	4.500	9.72	3.56	0.25	3.26	7.370	10.82	0.25	0.59	6.06	6.27	14.27
425	4.500	4.750	10.50	3.97	0.25	3.61	8.190	11.83	0.30	0.62	6.56	6.97	15.47
450	4.750	5.125	11.31	4.50	0.31	4.15	9.310	13.15	0.47	0.71	7.00	7.99	16.99
500	5.000	5.375	12.88	4.78	0.31	4.32	9.870	14.10	0.50	0.78	7.88	8.33	18.33
550	5.500	6.000	14.44	5.37	0.38	4.87	11.120	15.74	0.58	0.91	8.75	9.36	20.36
600	6.000	6.500	16.00	6.00	0.38	5.40	12.380	17.40	0.67	0.98	9.31	10.42	22.42
700	7.000	7.500	18.25	7.00	0.38	6.22	14.380	20.22	0.75	1.20	10.88	12.06	26.06
750	7.500	8.000	19.81	7.75	0.50	7.00	16.000	22.25	0.84	1.27	11.75	13.50	28.50
800	8.000	8.750	21.50	8.25	0.50	7.37	17.000	23.87	0.91	1.34	12.50	14.24	30.74
850	8.500	9.250	23.00	8.88	0.56	7.97	18.320	25.60	1.00	1.40	13.19	15.38	32.88
925	9.000	10.125	25.00	9.91	0.62	8.91	20.440	28.32	1.09	1.50	14.12	17.20	36.20



* Uses Series 52 hubs. Non-bored hubs available upon request.
 ** Hubs may be reversed for alternate shaft spacing.
 *** Both hubs reversed.

Size	Max. Horsepower Per 100 RPM	Max. RPM		Max. Continuous Torque (lb-in)	Peak Overload Torque (lb-in)	② Weight (lb)	② WR ² (lb-in ²)	③ Axial Capacity (in)
	Service Factor 1.0	① Not Balanced	① Balanced					
125	4.3	4,600	10,500	2,700	5,400	6.9	12.5	±0.036
162	8.5	4,200	9,700	5,350	10,700	9.3	24	±0.036
200	16.7	3,800	8,600	10,500	21,000	16	67	±0.036
225	27.8	3,700	8,400	17,500	35,000	19	85	±0.036
262	52.1	3,600	7,400	32,830	65,660	31	192	±0.043
312	81.6	3,000	6,700	51,400	102,800	46	384	±0.051
350	106	2,800	6,200	66,900	133,800	66	689	±0.056
375	159	2,500	5,800	100,300	200,600	88	1,160	±0.062
425	213	2,300	5,400	134,300	268,600	117	1,780	±0.067
450	239	2,200	5,000	150,400	300,800	154	2,690	±0.072
500	391	2,000	4,600	246,400	492,800	224	4,970	±0.082
550	524	1,900	4,200	330,400	660,800	324	8,970	±0.092
600	688	1,800	3,900	433,800	867,600	437	14,900	±0.102
700	1,071	1,700	3,600	674,800	1,349,600	657	29,000	±0.115
750	1,331	1,550	3,400	838,800	1,677,600	839	43,400	±0.125
800	1,712	1,450	3,200	1,078,700	2,157,400	1,040	63,900	±0.136
850	2,020	1,350	3,000	1,273,000	2,546,000	1,260	88,900	±0.144
925	2,735	1,300	2,800	1,724,000	3,448,000	1,690	140,000	±0.156

① See page 4 for explanation of RPM limits and balancing recommendations.
 ② Weight and WR² with standard length hubs, maximum bore and standard "C."
 ③ All Thomas disc couplings meet NEMA frame sleeve bearing motor specifications without modifications or the addition of end-float restricting devices.

Series 54RD Close-Coupled Coupling

Series 54RD couplings are specifically designed as replacements for close-coupled gear and grid couplings, and where overall shaft-to-shaft spacing is minimal. Materials of construction are identical to the Series 52. Stainless steel disc packs are supplied as standard.

To reduce maintenance costs, the Series 54RD is furnished with an axially split center member. This design permits the removal of the disc packs without moving the connected equipment. When specified, and based on speed requirements, the Series 54RD can be manufactured to meet API 610. If application requires API specification, please consult Rexnord.

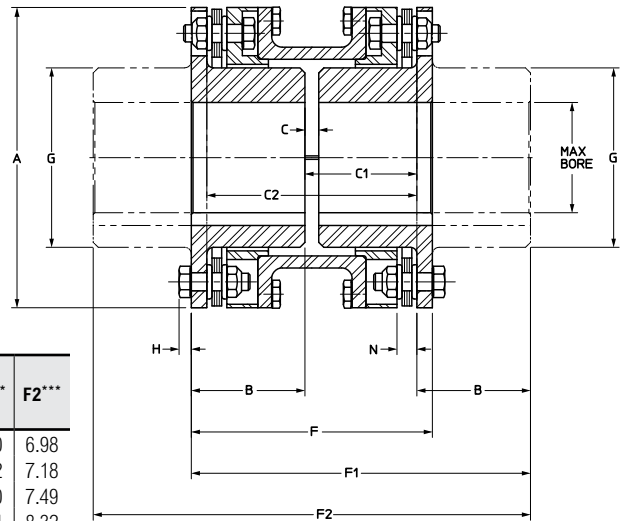

General Dimensions (in)

Size	Max Bore* Internal	Max Bore* External	A	B	C	C1**	F	F1**	H	N	G	C2***	F2***
125	1.19	1.38	3.69	1.84	0.12	1.71	3.80	5.39	0.17	0.27	1.75	3.30	6.98
162	1.62	1.88	4.34	1.88	0.12	1.77	3.88	5.52	0.17	0.29	2.34	3.42	7.18
200	2.25	2.25	5.44	2.12	0.12	1.97	4.36	6.22	0.22	0.36	3.25	3.80	7.49
225	2.38	2.63	5.69	2.19	0.12	2.03	4.50	6.40	0.22	0.36	3.50	3.94	8.32
262	2.75	3.13	6.62	2.59	0.19	2.42	5.37	7.61	0.25	0.47	4.12	4.65	9.83
312	3.38	3.63	7.81	2.84	0.19	2.62	5.87	8.31	0.30	0.50	5.00	5.05	10.73
350	3.75	4.00	8.69	3.28	0.25	3.06	6.81	9.62	0.34	0.54	5.50	5.87	12.43
375	4.19	4.50	9.69	3.56	0.25	3.27	7.37	10.40	0.39	0.59	6.06	6.27	13.39
425	4.50	4.75	10.50	3.97	0.25	3.61	8.19	11.55	0.42	0.62	6.56	6.97	14.91
450	4.75	5.13	11.31	4.50	0.31	4.16	9.31	13.16	0.47	0.71	7.00	7.99	16.99
500	5.00	5.38	12.88	4.72	0.31	4.27	9.75	13.71	0.50	0.78	7.88	8.21	17.65
550	5.50	6.00	14.44	5.31	0.38	4.81	11.00	15.44	0.58	0.91	8.75	9.24	19.86
600	6.00	6.50	16.00	6.00	0.38	5.39	12.38	17.39	0.67	0.98	9.31	10.42	22.42
700	7.00	7.50	18.25	7.00	0.38	6.22	14.38	20.22	0.75	1.19	10.88	12.06	26.06
750	7.50	8.00	19.81	7.75	0.50	7.00	16.00	22.50	0.84	1.27	11.75	13.50	29.00
800	8.00	8.75	21.50	8.25	0.50	7.37	17.00	23.87	0.91	1.34	12.50	14.24	30.74
850	8.50	9.25	23.00	8.88	0.56	7.97	18.32	25.73	1.00	1.40	13.19	15.38	33.14
925	9.00	10.12	25.00	9.91	0.62	8.91	20.44	28.73	1.09	1.50	14.12	17.20	37.02
1000	10.38	11.00	27.50	10.75	0.62	9.62	22.12	31.12	1.16	1.69	16.25	18.62	40.12

* Non-bored hubs available upon request.

** Hubs may be reversed for alternate shaft spacing.

*** Both hubs reversed.

NOTE: When hub is used with barrel positioned outside of spacer, a Series 52 hub is used.

Size	Max. Horsepower Per 100 RPM	Max. RPM		Max. Continuous Torque (lb-in)	Peak Overload Torque (lb-in)	② Weight (lb)	② WR ² (lb-in ²)	① Axial Capacity (in)
	Service Factor 1.0	Not Balanced	③ Balanced					
125	3.7	4,600	7,200	2,330	4,660	6.7	12	±0.036
162	6.9	4,200	7,000	4,360	8,720	9.7	24	±0.036
200	13.5	3,800	6,300	8,490	16,980	16.0	65	±0.036
225	17.0	3,700	6,000	10,700	21,400	18.0	80	±0.036
262	27.8	3,600	5,500	17,500	35,000	31.0	179	±0.043
312	38.6	3,000	5,000	24,300	48,600	47.4	399	±0.051
350	54.1	2,800	4,500	34,100	68,200	68.3	708	±0.056
375	81.1	2,500	4,000	51,100	102,200	94.4	1,240	±0.062
425	115.0	2,300	3,700	72,300	144,600	125.0	1,920	±0.067
450	130.0	2,200	3,400	82,200	164,400	165.0	2,900	±0.072
500	197.0	2,000	3,300	124,000	248,000	241.0	5,420	±0.082
550	341.0	1,900	2,800	215,000	430,000	347.0	9,810	±0.092
600	427.0	1,800	2,500	269,000	538,000	478.0	16,500	±0.102
700	549.0	1,700	2,500	346,000	692,000	713.0	31,900	±0.115
750	741.0	1,550	2,200	467,000	934,000	885.0	46,100	±0.125
800	920.0	1,450	2,100	580,000	1,160,000	1,100.0	67,500	±0.136
850	1,125.0	1,350	1,950	709,000	1,418,000	1,460.0	103,000	±0.144
925	1,503.0	1,300	1,850	947,000	1,894,000	1,960.0	162,000	±0.156
1000	2,063.0	1,200	1,750	1,300,000	2,600,000	2,440.0	247,000	±0.172

For larger sizes, consult Rexnord.

① All Thomas disc couplings meet NEMA frame sleeve bearing motor specifications without modifications or the addition of end-float restricting devices.

② Weight and WR² at maximum bore.

③ For higher speeds, consult Rexnord.

The standard DBZ coupling has two hubs inverted inside the disc pack and is used where overall shaft to shaft spacing is minimal.

DBZ style has both hubs with inverted orientation.

DBZ-A style has one hub extended to permit taper boring.

DBZ-B style has both hubs extended to allow for greater spacing where required.

Construction

Hubs and Center Assembly: Carbon steel

Bolts: Alloy steel

Disc Packs: Tomaloy

Coatings Available: Consult Rexnord

Other disc pack materials such as stainless steel, Monel and Inconel are available; please consult Rexnord.

Misalignment: 1/2° per disc pack

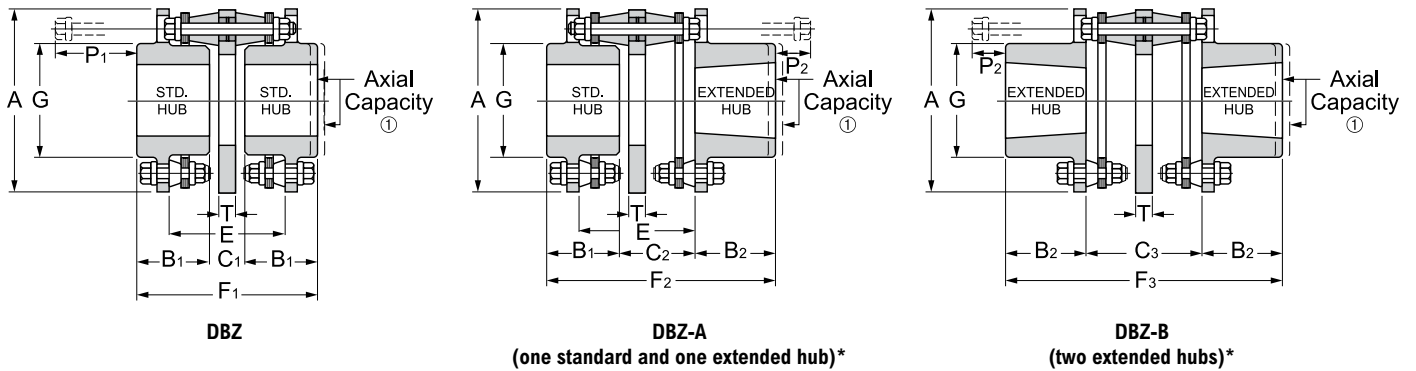

General Dimensions (in)

Size	Standard Hub Max. Bore	Extended Hub Max. Bore	A	B1	B2	C1	C2	C3	E	F1	F2	F3	G	P1	P2	T
50	0.63	0.63	2.00	0.88	0.88	0.32	0.84	1.36	1.36	2.08	2.60	3.12	1.00	1.25	0.78	0.19
62	0.75	0.75	2.44	1.09	1.09	0.38	1.05	1.72	1.72	2.56	3.23	3.90	1.19	1.56	1.06	0.25
75	0.88	0.88	2.69	1.12	1.12	0.37	1.06	1.75	1.75	2.61	3.30	3.99	1.44	1.56	1.06	0.25
101	1.13	1.16	3.22	1.38	1.38	0.69	1.39	2.08	2.08	3.45	4.15	4.84	1.69	1.69	1.00	0.31
126	1.38	1.38	3.84	1.50	1.62	0.96	1.70	2.45	2.45	3.96	4.82	5.69	2.06	2.00	1.13	0.41
163	1.88	1.88	4.56	1.69	1.88	0.95	1.70	2.45	2.45	4.33	5.27	6.21	2.75	1.81	0.88	0.41
201	2.13	2.25	5.34	1.94	2.12	0.96	1.96	2.96	2.96	4.84	6.02	7.20	3.28	2.31	1.13	0.56
226	2.38	2.63	6.06	2.38	2.62	1.22	2.53	3.84	3.84	5.98	7.53	9.08	3.78	2.69	1.13	0.66
263	2.88	3.00	7.00	2.75	3.00	1.31	2.81	4.31	4.31	6.81	8.56	10.31	4.44	3.00	1.25	0.75
301	3.13	3.50	8.00	3.12	3.44	1.50	3.19	4.88	4.88	7.74	9.75	11.76	5.06	3.56	1.56	0.84
351	3.63	4.00	9.38	3.69	4.06	1.80	3.86	5.92	5.92	9.18	11.61	14.04	5.81	4.50	2.06	1.06
401	4.13	4.50	10.69	4.19	4.62	1.94	4.32	6.70	6.70	10.32	13.13	15.94	6.63	5.13	2.31	1.19
451	4.63	4.75	12.13	4.75	5.25	2.12	4.72	7.28	7.28	11.66	14.72	17.78	7.38	5.44	2.38	1.34

Size	Max. Horsepower Per 100 RPM	Max. RPM		Max. Continuous Torque (lb-in)	Peak Overload Torque (lb-in)	② Weight (lb)			② WR ² (lb-in ²)			① Axial Capacity (in)
	Service Factor 1.0	Not Balanced	Balanced			DBZ	DBZ-A	DBZ-B	DBZ	DBZ-A	DBZ-B	
50	0.23	6,000	9,000	145	220	0.7	0.7	0.7	0.3	0.3	0.3	±0.023
62	0.39	6,000	8,200	246	370	1.5	1.5	1.5	0.7	0.7	0.7	±0.028
75	0.56	6,000	7,800	353	530	1.9	1.9	1.9	1.5	1.5	1.5	±0.032
101	1.10	6,000	7,100	693	1,040	3.3	3.3	3.3	4.5	4.5	4.5	±0.038
126	2.00	5,500	6,500	1,260	1,900	5.5	5.6	5.7	9.9	10.1	10.1	±0.046
163	2.70	5,000	6,000	1,700	2,600	8.4	8.6	8.8	21	21	22	±0.057
201	4.79	4,600	5,500	3,020	4,500	14.4	14.4	15.4	53	53	54	±0.067
226	8.73	4,100	5,200	5,500	8,300	21	22	23	95	95	105	±0.076
263	13.60	3,700	4,800	8,600	12,900	33	34	35	199	209	209	±0.089
301	20.50	3,300	4,500	12,900	19,400	50	52	54	365	375	385	±0.102
351	35.90	2,900	4,100	22,600	33,900	83	87	90	916	936	965	±0.118
401	52.70	2,700	3,900	33,200	49,800	125	125	135	1,705	1,710	1,710	±0.136
451	68.90	2,600	3,600	43,400	65,100	170	180	180	3,168	3,170	3,270	±0.154

① All Thomas disc couplings meet NEMA frame sleeve bearing motor specifications without modifications or the addition of end-float restricting devices.

② Weight and WR² at maximum bore.

* Extended hubs can be supplied with straight bores or taper bores.

Optimized design and construction include stainless disc packs and corrosion protection; additional modifications may be made to reduce coupling weight, or special mountings to make it an economical alternative to high performance styles. Common engineered solutions are available such as torque overload protection, electrically insulated, spark resistant, and alloy construction.

The XTZR52 couplings are an all-purpose high-speed, high-torque coupling used where minimum coupling weight is desirable. The XTZR52 couplings are API 610, ISO 14691 compliant when specified, and ATEX II 2GD c T6 certified. Common applications include motor and turbine driven pumps, compressors, fans, synchronized rollers, wire feeders and blowers.

Construction

Hubs and Center assembly: Carbon steel

Bolts: Alloy steel

Disc Packs: Stainless steel. Max misalignment is 2/3° per disc pack for sizes 494 & 644, 1/2° per disc pack for sizes 726-996, and 1/3° per disc pack for sizes 1088-5258.

Coatings Available: Manganese Phosphate provided as standard. Other coatings available upon request.

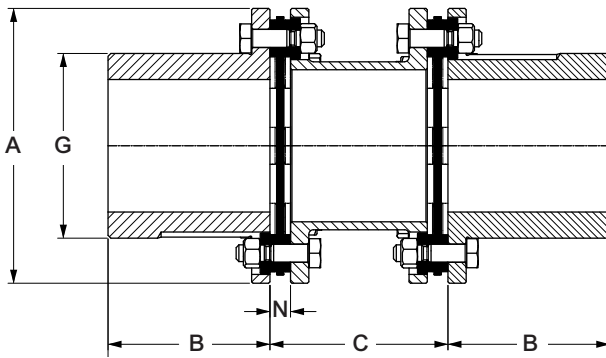

STANDARD HUB (WITHOUT ADAPTER)

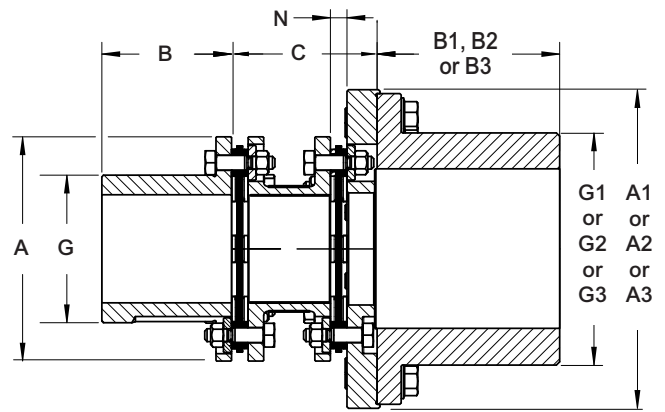

WITH ADAPTER AND LARGE HUB



WITHOUT ADAPTER



WITH ADAPTER

Example Selection:

1. Select coupling size 1088 for 19,000 lb-in torque and 2.5 in pump shaft diameter.
2. Select XXL 2nd hub for 3.5 in motor shaft diameter.
3. Therefore, coupling is a 1088 XTSR52 XXL.

A 1088 XTSR52 XXL has one hub with 2.5 in max bore and one hub with 4 in max bore.

General Coupling Data

An optional one size larger LH hub, two sizes larger XL hub, or three sizes larger XXL hub is available with adapter to increase bore capacity.

Size	Max. Cont. Torque (lb•in) ⑤	③ Std Hub Max. Bore	③ LH Hub Max. Bore	③ XL Hub Max. Bore	③ XXL Hub Max. Bore	Min. C (in)	Min. C with Adapter (in)	⑥⑦ Max. C (in)	Max. Speed (rpm)		① Axial Capacity (in)	N (in)	② WR ² (lb•in ²)
									④ Not Balanced	Balanced			
494	750	1.00	1.13	1.50	1.63	3.23	3.74	6.40	13,800	23,000	±0.05	0.339	1.65
644	1,280	1.50	1.50	—	2.00	3.23	3.78	9.40	12,500	21,500	±0.07	0.339	3.89
726	2,630	1.75	—	2.00	2.38	3.23	3.72	14.68	12,000	20,000	±0.05	0.339	6.55
826	4,900	2.00	—	2.38	2.88	3.47	4.06	14.74	10,900	18,500	±0.06	0.368	15.4
996	8,210	2.25	2.38	2.88	3.38	3.84	4.59	30.76	9,800	15,000	±0.07	0.378	32.6
1088	19,400	2.50	2.88	3.38	4.00	4.06	4.80	30.82	9,000	14,000	±0.05	0.408	64.2
1298	31,400	3.00	3.38	4.00	4.50	4.56	5.46	31.02	8,000	12,000	±0.06	0.508	152
1548	52,300	3.50	4.00	4.50	5.00	5.04	6.11	31.16	7,100	10,000	±0.07	0.582	336
1698	72,500	4.00	4.50	5.00	5.50	6.00	7.22	31.24	6,600	9,100	±0.08	0.622	568
1928	98,200	4.50	5.00	5.50	6.00	6.30	7.59	31.34	6,100	8,500	±0.09	0.672	968
2068	136,000	4.75	5.50	6.00	6.50	6.93	8.47	31.45	5,800	7,800	±0.10	0.725	1,470
2278	176,000	5.38	6.00	6.50	7.75	8.38	9.97	31.51	5,500	7,100	±0.11	0.755	2,430
2468	232,000	5.75	6.50	7.75	8.63	8.73	10.42	31.61	5,200	6,500	±0.12	0.807	3,550
2698	318,000	6.00	7.75	8.63	9.13	9.36	11.27	43.85	4,800	6,000	±0.13	0.924	5,540
2888	416,000	6.75	8.63	9.13	10.00	10.63	12.68	43.98	4,600	5,700	±0.14	0.991	8,570
3058	461,000	7.13	9.13	10.00	11.00	10.63	12.69	43.98	4,400	5,400	±0.15	0.991	11,100
3358	622,000	8.00	10.00	11.00	11.50	11.88	14.21	44.15	4,200	4,700	±0.16	1.076	17,700
3668	834,000	8.88	11.00	11.50	12.25	12.62	15.09	44.39	3,900	4,400	±0.17	1.196	29,100
3908	909,000	9.50	11.50	12.25	14.00	12.62	15.12	44.39	3,800	4,100	±0.19	1.196	37,600
4178	1,130,000	10.13	12.25	14.00	15.00	13.50	16.26	44.55	3,600	3,900	±0.20	1.277	52,700
4588	1,670,000	11.00	14.00	15.00	16.00	19.62	22.77	40.83	3,400	3,600	±0.22	1.415	90,800
4918	2,080,000	11.75	15.00	16.00	—	20.38	23.68	41.00	3,200	3,300	±0.23	1.501	129,000
5258	2,510,000	12.63	16.00	—	—	21.25	24.82	41.17	3,100	3,100	±0.25	1.586	179,000

Size	Std A (in)	LH A1 (in)	XL A2 (in)	XXL A3 (in)	Std B (in)	LH B1 (in)	XL B2 (in)	XXL B3 (in)	Std G (in)	LH G1 (in)	XL G2 (in)	XXL G3 (in)	② Std Weight (lb)	Weight Change Per in of "C" (lb/in)
494	2.76	2.77	3.36	3.74	0.79	0.79	0.98	1.38	1.61	1.65	2.28	2.32	1.9	0.091
644	3.35	3.36	—	4.25	0.98	0.98	—	1.65	2.20	2.28	—	2.87	3.0	0.169
726	3.74	—	4.25	5.08	1.18	—	1.65	2.01	2.51	—	2.87	3.39	3.9	0.203
826	4.25	—	5.08	5.51	1.97	—	2.01	3.23	2.83	—	3.39	4.09	7.4	0.315
996	5.08	5.08	5.51	6.54	1.97	2.01	3.23	3.74	3.32	3.39	4.09	4.84	10.5	0.286
1088	5.51	5.51	6.54	7.83	3.19	3.23	3.74	4.49	3.63	4.09	4.84	5.71	18.4	0.551
1298	6.54	6.54	7.83	8.66	3.82	3.74	4.49	4.80	4.35	4.84	5.71	6.50	29.9	0.687
1548	7.76	7.83	8.66	9.66	3.82	4.49	4.80	5.31	5.21	5.71	6.50	7.17	45.9	0.983
1698	8.58	8.66	9.66	10.39	4.33	4.80	5.31	6.10	5.78	6.50	7.17	7.87	63.9	1.23
1928	9.65	9.66	10.39	11.44	4.33	5.31	6.10	6.57	6.60	7.17	7.87	8.66	84.2	1.50
2068	10.39	10.39	11.44	12.32	4.92	6.10	6.57	7.48	7.03	7.87	8.66	9.29	110	1.90
2278	11.46	11.44	12.32	13.58	5.71	6.57	7.48	7.28	7.74	8.66	9.29	11.02	154	2.21
2468	12.32	12.32	13.58	15.00	5.91	7.48	7.28	7.87	8.41	9.29	11.02	12.13	192	2.66
2698	13.50	13.58	15.00	15.94	5.91	7.28	7.87	7.52	9.14	11.02	12.13	13.07	245	3.39
2888	14.61	15.00	15.94	17.20	6.89	7.87	7.52	8.86	9.69	12.13	13.07	13.98	331	4.35
3058	15.55	15.94	17.20	18.98	7.28	7.52	8.86	10.12	10.35	13.07	13.98	15.67	380	4.32
3358	16.81	17.20	18.98	19.80	9.65	8.86	10.12	9.80	11.34	13.98	15.67	16.50	512	5.37
3668	18.35	18.98	19.80	20.83	11.06	10.12	9.80	10.47	12.41	15.67	16.50	17.48	725	6.58
3908	19.29	19.80	20.83	23.94	11.93	9.80	10.47	11.81	13.35	16.50	17.48	19.84	840	6.46
4178	20.63	20.83	23.94	25.51	12.68	10.47	11.81	12.60	14.22	17.48	19.84	21.46	1030	7.51
4588	23.11	23.94	25.51	26.69	13.78	11.81	12.60	13.62	15.44	19.84	21.46	22.64	1460	10.5
4918	24.80	25.51	26.69	—	14.76	12.60	13.62	—	16.55	21.46	22.64	—	1800	12.4
5258	26.46	25.51	—	—	15.79	—	—	—	17.70	—	—	—	2190	13.9

- ① All Thomas disc couplings meet NEMA frame sleeve bearing motor specifications without modification or the addition of end-float restricting devices.
- ② Weight and WR² of couplings without adapters at maximum bore and minimum "C" dimension listed.
- ③ Consult Rexnord for minimum rough bore sizes.
- ④ XTSR52 couplings meet AGMA Class 9 balance requirements as manufactured with interference fit bore and close fit keyway. If clearance fit and/or setscrews are required, consult Rexnord.
- ⑤ Peak Overload Torque (lb•in) is twice the Maximum Continuous Torque.
- ⑥ Consult Rexnord for C lengths greater than 31.61 in for sizes 2698-5258.
- ⑦ If larger C lengths are required than the listed Max., refer to XTSR52 page.

Component Part Numbers

Size	① Standard Hub	⑥ LH Hub + Cap Screw Kit	⑥ XL Hub + Cap Screw Kit	⑥ XXL Hub + Cap Screw Kit	Adapters ⑤			Inch Standard C Dimensions						
					LH Part No.	XL Part No.	XXL Part No.	3.5"	3.75"	4.375"	5.0"	7.5"	8.0"	9.0"
								② Standard Center Member When Adapter Not Used						
494	10003201	10611141	10611142	10001611	10003209	10003210	10003211	10003219	10003220	-	10003221	-	-	-
644	10003202	10611142	-	10001612	10003212	-	10003214	10003227	10003228	-	10003229	-	-	-
726	10001191	10001611	10001612	10001613	10000241	10001161	10002621	10000921	10467168	-	10000922	-	-	-
826	10001192	10001612	10001613	10001614	10000242	10001162	10002622	10000923	10467167	-	10000924	-	-	-
996	10001193	10001613	10001614	10001615	10000243	10001163	10002623	-	-	10000925	10000926	-	-	-
1088	10001194	10001614	10001615	10001616	10000244	10001164	10002624	-	-	10000927	10000928	-	-	-
1298	10001195	10001615	10001616	10001617	10000245	10001165	10002625	-	-	-	10000930	-	-	-
1548	10001196	10001616	10001617	10001618	10000246	10001166	10002626	-	-	-	10000931	10000932	10000933	-
1698	10001197	10001617	10001618	10001619	10000247	10001167	10002627	-	-	-	10000934	10000935	-	-
1928	10001198	10001618	10001619	10001620	10000248	10001168	10002628	-	-	-	10000936	10000937	-	10000938
2068	10001199	10001619	10001620	10001621	10000249	10001169	10002629	-	-	-	10000939	10000940	10000941	-
2278	10001200	10001620	10001621	10001622	10000250	10001170	10002630	-	-	-	-	-	-	10000943
2468	10001201	10001621	10001622	10001623	10000251	10001171	10002631	-	-	-	-	-	-	10000944
2698	10001202	10001622	10001623	10001624	10000252	10001172	10002632	-	-	-	-	-	-	-
2888	10001203	10001623	10001624	10001631	10000253	10001173	10002633	-	-	-	-	-	-	-
3058	10001204	10001624	10001631	10001625	10000254	10001174	10002634	-	-	-	-	-	-	-
3358	10001205	10001631	10001625	10001626	10000255	10001175	10002635	-	-	-	-	-	-	-
3668	10001206	10001625	10001626	10001627	10000256	10001176	10002636	-	-	-	-	-	-	-
3908	10001207	10001626	10001627	10001628	10000257	10001177	10002637	-	-	-	-	-	-	-
4178	10001208	10001627	10001628	10001629	10000258	10001178	10002638	-	-	-	-	-	-	-
4588	10001209	10001628	10001629	10001630	10000259	10001179	10002639	-	-	-	-	-	-	-
4918	10001210	10001629	10001630	-	-	10000260	10001180	-	-	-	-	-	-	-
5258	10001211	10001630	-	-	10000261	-	-	-	-	-	-	-	-	-

NOTE: An optional one size larger LH hub, two sizes larger XL hub, or three sizes larger XXL hub is available with adapter to increase bore capacity.

Size	Metric Standard C Dimensions				Inch Standard C Dimensions When Adapter Used					Metric Standard C Dimensions				③ Disc Pack Hardware Kit	④ Disc Pack
	100mm	140mm	180mm	250mm	4.375"	5.0"	7.5"	8.0"	9.0"	100mm	140mm	180mm	250mm		
	② Standard Center Member When Adapter Not Used				② Standard Center Member When Adapter Used (LH, XL, XXL)										
494	10003222	10003223	-	-	-	10003224	-	-	-	10003225	10003226	-	-	10611144	10003753
644	10003230	10003231	-	-	-	10003232	-	-	-	10003233	10003234	-	-	10611145	10002803
726	10000831	10000910	-	-	-	10447053	-	-	-	10399144	10447054	-	-	10001561	10000091
826	10000832	10000911	-	-	10447077	10447078	-	-	-	-	10397202	-	-	10001562	10000092
996	10000912	10000833	10000913	-	-	10447082	-	-	-	-	10399148	10397204	-	10001563	10000093
1088	-	10000834	10000914	-	-	10404466	-	-	-	-	10399150	10397205	-	10001564	10000094
1298	-	10000835	10000915	-	-	-	-	-	-	-	10447083	10397206	-	10001565	10000095
1548	-	10000916	10000836	10000917	-	-	10447085	10447086	-	-	-	10399155	10447084	10001566	10000096
1698	-	-	10000837	10000918	-	-	10447087	10447088	-	-	-	-	10397207	10001567	10000097
1928	-	-	10000838	10000919	-	-	-	10447089	10447090	-	-	-	10397208	10001568	10000098
2068	-	-	10000920	10000839	-	-	-	-	10447043	-	-	-	10397211	10001569	10000099
2278	-	-	-	10000840	-	-	-	-	-	-	-	-	-	10001570	10000100
2468	-	-	-	10000841	-	-	-	-	-	-	-	-	-	10001571	10000101
2698	-	-	-	10000842	-	-	-	-	-	-	-	-	-	10001572	10000102
2888	-	-	-	10000843	-	-	-	-	-	-	-	-	-	10001573	10000103
3058	-	-	-	10000844	-	-	-	-	-	-	-	-	-	10001574	10000104
3358	-	-	-	10000845	-	-	-	-	-	-	-	-	-	10001575	10000105
3668	-	-	-	-	-	-	-	-	-	-	-	-	-	10001576	10000106
3908	-	-	-	-	-	-	-	-	-	-	-	-	-	10001577	10000107
4178	-	-	-	-	-	-	-	-	-	-	-	-	-	10001578	10000108
4588	-	-	-	-	-	-	-	-	-	-	-	-	-	10001579	10000109
4918	-	-	-	-	-	-	-	-	-	-	-	-	-	10001580	10000110
5258	-	-	-	-	-	-	-	-	-	-	-	-	-	10001581	10000111

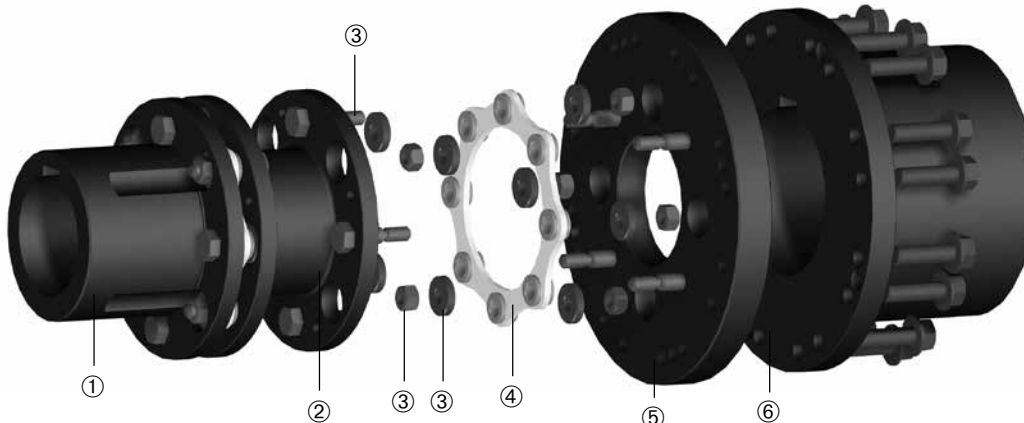

The optimized 3-piece design allows for the smallest possible package for an application. The hubs are pilot fitted to the factory assembled center member. The design allows for repeatable installations without special tooling. Additional modifications may be made to reduce coupling weight, or special mountings to make it an economical option on various critical and high speed applications. Common engineered solutions are available such as torque overload protection, electrically insulated, spark resistant and alloy construction.

The XTSR71 couplings are designed for spacer type coupling critical applications including API applications. The XTSR71 couplings are API 610 and ISO 14691 compliant, API 671 (ISO 10441) compliant when specified, and ATEX II 2GD c T6 certified. Common applications include motor and turbine driven pumps, compressors, fans, synchronized rollers, wire feeders and blowers.

Construction

Hubs and Center assembly: Carbon steel

Bolts: Alloy steel

Disc Packs: Stainless steel. Max misalignment is 2/3° per disc pack for sizes 494 & 644, 1/2° per disc pack for sizes 726-996, and 1/3° per disc pack for sizes 1088-5258.

Coatings Available: Manganese Phosphate provided as standard. Other coatings available upon request.

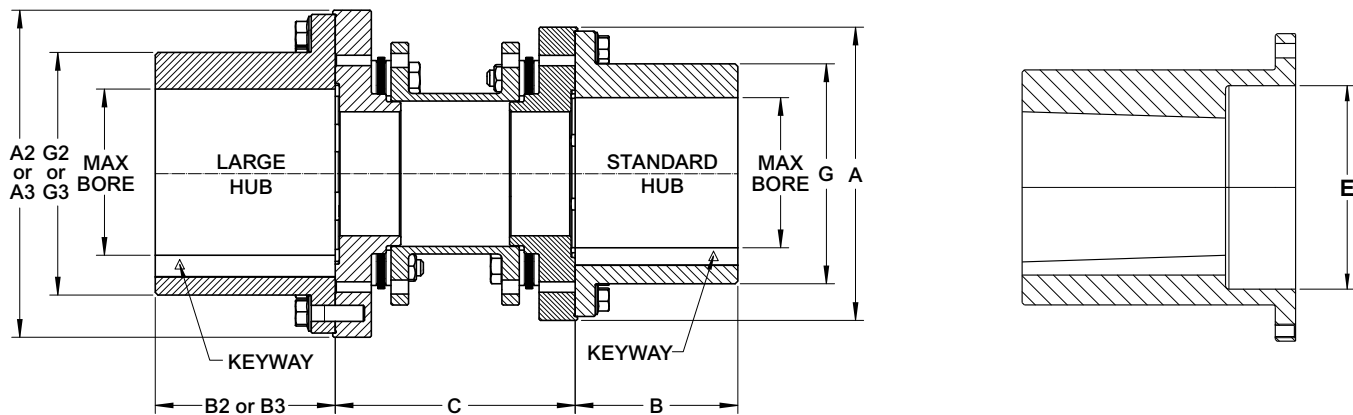

Example Selection:

1. Select coupling size 1088 for 19,000 lb-in torque and 2.5 in pump shaft diameter.
2. Select XXL 2nd hub for 3.5 in motor shaft diameter.
3. Therefore, coupling is a 1088 XTSR71 XXL.

1088 XTSR71 XXL has one hub with 2.88 in max bore and one hub with 4 in max bore.

General Coupling Data

An optional one size larger XL hub or two sizes larger XXL hub is available to increase bore capacity.

Size	Max. Cont. Torque (lb•in) ⑤	③ Std Hub Max. Bore	③ XL Hub Max. Bore	③ XXL Hub Max. Bore	Min. C (in)	⑥⑦ Max. C (in)	Max. Speed (rpm)		Axial Capacity (in) ①	Max Counter Bore E (in)
							④ Not Balanced	Balanced		
494	750	1.13	1.50	1.63	2.56	6.40	13,800	23,000	±0.05	1.25
644	1,280	1.50	—	2.00	2.68	10.50	12,500	21,500	±0.07	1.88
726	2,630	1.63	2.00	2.38	2.56	15.68	12,000	20,000	±0.05	2.08
826	4,900	2.00	2.38	2.88	3.03	15.89	10,900	18,500	±0.06	2.58
996	8,210	2.38	2.88	3.38	3.62	32.30	9,800	15,000	±0.07	3.03
1088	19,400	2.88	3.38	4.00	3.78	32.28	9,000	14,000	±0.05	3.47
1298	31,400	3.38	4.00	4.50	4.53	32.80	8,000	12,000	±0.06	4.13
1548	52,300	4.00	4.50	5.00	5.31	33.33	7,100	10,000	±0.07	4.86
1698	72,500	4.50	5.00	5.50	5.94	33.65	6,600	9,100	±0.08	5.60
1928	98,200	5.00	5.50	6.00	6.34	33.87	6,100	8,500	±0.09	6.17
2068	136,000	5.50	6.00	6.50	7.36	34.59	5,800	7,800	±0.10	6.70
2278	176,000	6.00	6.50	7.75	7.72	34.69	5,500	7,100	±0.11	7.42
2468	232,000	6.50	7.75	8.63	8.23	34.99	5,200	6,500	±0.12	7.85
2698	318,000	7.75	8.63	9.13	9.29	47.62	4,800	6,000	±0.13	9.69
2888	416,000	8.63	9.13	10.00	10.04	48.09	4,600	5,700	±0.14	10.69
3058	461,000	9.13	10.00	11.00	10.12	48.13	4,400	5,400	±0.15	11.73
3358	622,000	10.00	11.00	11.50	11.30	48.85	4,200	4,700	±0.16	12.37
3668	834,000	11.00	11.50	12.25	12.20	49.34	3,900	4,400	±0.17	13.97
3908	909,000	11.50	12.25	14.00	12.24	49.39	3,800	4,100	±0.19	14.85
4178	1,130,000	12.25	14.00	15.00	13.39	50.11	3,600	3,900	±0.20	15.64
4588	1,670,000	14.00	15.00	16.00	15.20	47.13	3,400	3,600	±0.22	17.72
4918	2,080,000	15.00	16.00	—	16.06	47.60	3,200	3,300	±0.23	19.21
5258	2,510,000	16.00	—	—	17.24	48.31	3,100	3,100	±0.25	20.19

Size	Std A (in)	XL A2 (in)	XXL A3 (in)	Std B (in)	XL B2 (in)	XXL B3 (in)	Std G (in)	XL G2 (in)	XXL G3 (in)	② Std Weight (lb)	Weight Change Per in of "C" (lb/in)	② WR ² (lb•in ²)
494	2.77	3.36	3.74	0.79	0.98	1.38	1.65	2.28	2.32	3.47	0.088	3.15
644	3.36	—	4.25	0.98	—	1.65	2.28	—	2.87	5.50	0.137	7.62
726	3.74	4.25	5.08	1.38	1.65	2.01	2.32	2.87	3.39	6.83	0.174	12.4
826	4.25	5.08	5.51	1.65	2.01	3.23	2.87	3.39	4.09	11.0	0.300	26.3
996	5.08	5.51	6.54	2.01	3.23	3.74	3.39	4.09	4.84	18.5	0.281	64.2
1088	5.51	6.54	7.83	3.23	3.74	4.49	4.09	4.84	5.71	27.6	0.541	115
1298	6.54	7.83	8.66	3.74	4.49	4.80	4.84	5.71	6.50	45.4	0.661	272
1548	7.83	8.66	9.66	4.49	4.80	5.31	5.71	6.50	7.17	76.3	0.901	646
1698	8.66	9.66	10.39	4.80	5.31	6.10	6.50	7.17	7.87	104	1.20	1,090
1928	9.66	10.39	11.44	5.31	6.10	6.57	7.17	7.87	8.66	138	1.40	1,820
2068	10.39	11.44	12.32	6.10	6.57	7.48	7.87	8.66	9.29	187	1.82	2,870
2278	11.44	12.32	13.58	6.57	7.48	7.28	8.66	9.29	11.02	243	2.11	4,440
2468	12.32	13.58	15.00	7.48	7.28	7.87	9.29	11.02	12.13	315	2.52	6,630
2698	13.58	15.00	15.94	7.28	7.87	7.52	11.02	12.13	13.07	406	3.20	11,300
2888	15.00	15.94	17.20	7.87	7.52	8.86	12.13	13.07	13.98	567	4.01	18,300
3058	15.94	17.20	18.98	7.52	8.86	10.12	13.07	13.98	15.67	604	4.05	23,200
3358	17.20	18.98	19.80	8.86	10.12	9.80	13.98	15.67	16.50	807	5.08	35,500
3668	18.98	19.80	20.83	10.12	9.80	10.47	15.67	16.50	17.48	1,150	6.23	60,100
3908	19.80	20.83	23.94	9.80	10.47	11.81	16.50	17.48	19.84	1,180	6.21	71,400
4178	20.83	23.94	25.51	10.47	11.81	12.60	17.48	19.84	21.46	1,430	7.28	96,000
4588	23.94	25.51	26.69	11.81	12.60	13.62	19.84	21.46	22.64	2,190	10.0	185,000
4918	25.51	26.69	—	12.60	13.62	—	21.46	22.64	—	2,650	11.8	260,000
5258	26.69	—	—	13.62	—	—	22.64	—	—	3,130	13.1	341,000

- ① All Thomas disc couplings meet NEMA frame sleeve bearing motor specifications without modification or the addition of end-float restricting devices.
- ② Weight and WR² of couplings with standard adapters at maximum bore and minimum "C" dimension listed.
- ③ Consult Rexnord for minimum rough bore sizes.
- ④ XTSR71 couplings meet AGMA Class 9 balance requirements as manufactured with interference fit bore and close fit keyway. If clearance fit and/or setscrews are required, consult Rexnord.
- ⑤ Peak Overload Torque (lb•in) is twice the Maximum Continuous Torque.
- ⑥ Consult Rexnord on C lengths greater than 34.99" for sizes 2698-5258.
- ⑦ If larger C lengths are required than the listed maxes, refer to XTSR71 page.

Component Part Numbers

Size	① Standard Hub + Cap Screw Kit	XL Hub + Cap Screw Kit	② Standard Adapter	XL Adapter	XXL Adapter	Inch Standard C Dimensions							
						3.5"	3.75"	4.375"	5.0"	7.0"	7.5"	8.0"	9.0"
						③ Standard Center Member STD, XL, XXL							
494	10611141	10611142	10003755	10003215	10003216	10003235	10003236	—	10003237	—	—	—	—
644	10611142	—	10003754	—	10003218	10003240	10003241	—	10003242	—	—	—	—
726	10001611	10001612	10001131	10001781	10002805	10000871	10311913	10000872	10000873	—	—	—	—
826	10001612	10001613	10001132	10001782	10002806	10355817	10319474	10000875	10000876	—	—	—	—
996	10001613	10001614	10001133	10001783	10002807	—	10613540	10000877	10000878	10000879	—	—	—
1088	10001614	10001615	10001134	10001784	10002808	—	—	—	10000880	10000881	—	—	—
1298	10001615	10001616	10001135	10001785	10002809	—	—	—	10000882	10000883	—	—	—
1548	10001616	10001617	10001136	10001786	10002810	—	—	—	—	10000885	—	—	—
1698	10001617	10001618	10001137	10001787	10002811	—	—	—	—	10000886	—	—	—
1928	10001618	10001619	10001138	10001788	10002812	—	—	—	—	10000887	10000888	10000889	—
2068	10001619	10001620	10001139	10001789	10002813	—	—	—	—	—	—	10000891	—
2278	10001620	10001621	10001140	10001790	10002814	—	—	—	—	—	—	10000892	—
2468	10001621	10001622	10001141	10001791	10002815	—	—	—	—	—	—	—	10000893
2698	10001622	10001623	10001142	10001792	10002816	—	—	—	—	—	—	—	—
2888	10001623	10001624	10001143	10001793	10002817	—	—	—	—	—	—	—	—
3058	10001624	10001631	10001144	10001794	10002818	—	—	—	—	—	—	—	—
3358	10001631	10001625	10001145	10001795	10002819	—	—	—	—	—	—	—	—
3668	10001625	10001626	10001146	10001796	10002820	—	—	—	—	—	—	—	—
3908	10001626	10001627	10001147	10001797	10002821	—	—	—	—	—	—	—	—
4178	10001627	10001628	10001148	10001798	10002822	—	—	—	—	—	—	—	—
4588	10001628	10001629	10001149	10001799	10002823	—	—	—	—	—	—	—	—
4918	10001629	10001630	10001150	10001800	—	—	—	—	—	—	—	—	—
5258	10001630	—	10001151	—	—	—	—	—	—	—	—	—	—

NOTE: The XXL hub+capscrew kit is the same hub+capscrew kit as the next size XL. For example, the 996 XXL hub+capscrew kit is 10001615.

Size	Metric Standard C Dimensions				④ Disc Pack Hardware Kit	⑤ Disc Pack
	100mm	140mm	180mm	250mm		
	③ Standard Center Member STD, XL, XXL					
494	10003238	10003239	—	—	10611144	10003753
644	10003243	10003244	—	—	10611145	10002803
726	10000801	10000860	—	—	10001561	10000091
826	10000802	10000861	—	—	10001562	10000092
996	10000862	10000803	10000863	—	10001563	10000093
1088	—	10000804	10000864	—	10001564	10000094
1298	—	10000805	10000865	10447569	10001565	10000095
1548	—	10000866	10000806	10000867	10001566	10000096
1698	—	—	10000807	10000868	10001567	10000097
1928	—	—	10000808	10000869	10001568	10000098
2068	—	—	—	10000809	10001569	10000099
2278	—	—	—	10000810	10001570	10000100
2468	—	—	—	10000811	10001571	10000101
2698	—	—	—	10000812	10001572	10000102
2888	—	—	—	—	10001573	10000103
3058	—	—	—	—	10001574	10000104
3358	—	—	—	—	10001575	10000105
3668	—	—	—	—	10001576	10000106
3908	—	—	—	—	10001577	10000107
4178	—	—	—	—	10001578	10000108
4588	—	—	—	—	10001579	10000109
4918	—	—	—	—	10001580	10000110
5258	—	—	—	—	10001581	10000111

NOTE: An optional one size larger XL hub or two sizes larger XXL hub is available to increase bore capacity.

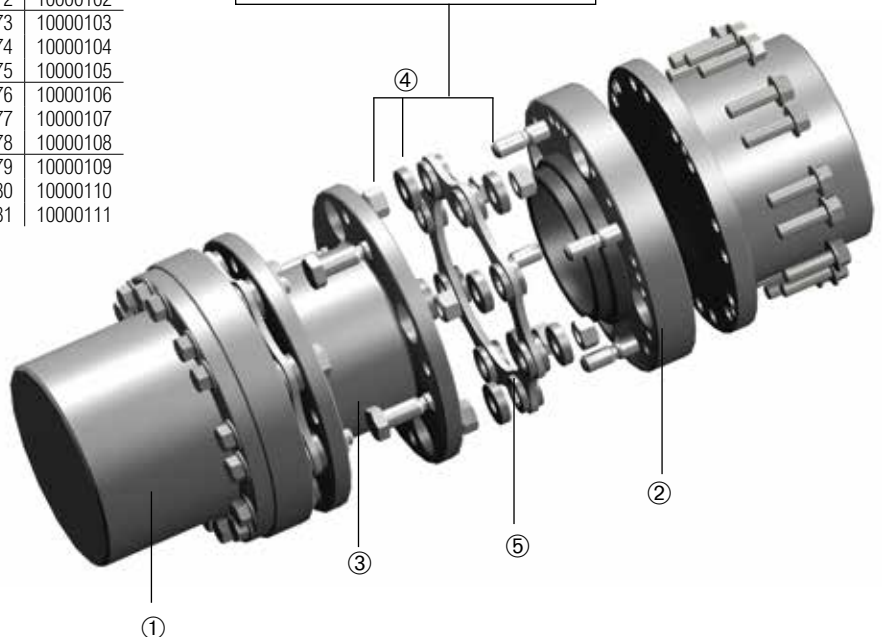
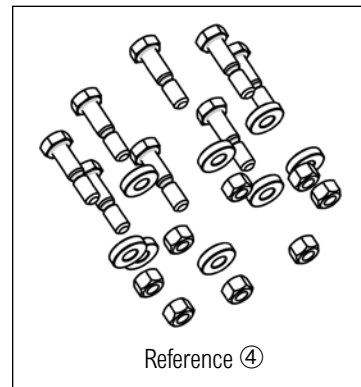

Characteristics

- Medium-high torque
- No shaft-hub axial movement
- Limited installation time
- Quick dismantling

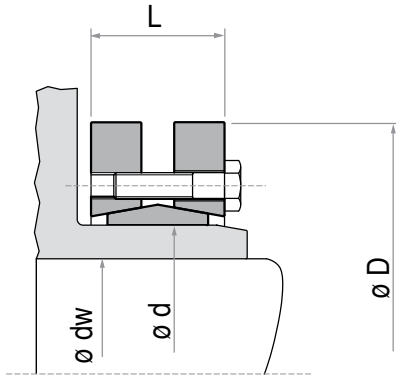

TLK 603 shown mounted on separately sold XTSR71 coupling.

TLK 603

Tollok TLK 603 $\varnothing d$ (in)	Shaft O.D. $\varnothing dw$		Max. Continuous Torque (lb-in)		Tollok Data			XTSR71 Coupling Size												
	Min (in)	Max (in)	at Min dw	at Max dw	$\varnothing D$ (in)	L (in)	Weight (lb)	726	826	996	1088	1298	1548	1698	1928	2068	2278	2468	2698	
1.181	0.945	1.024	2,652	3,363	2.362	0.846	0.7													
1.417	1.102	1.220	3,894	5,576	2.835	0.925	1													
1.732	1.260	1.417	5,487	7,612	3.150	1.004	1													
1.969	1.496	1.654	8,320	12,214	3.543	1.083	2													
2.165	1.654	1.890	10,267	16,639	3.937	1.201	2													
2.441	1.890	2.047	16,374	21,242	4.331	1.201	3													
2.677	1.969	2.362	17,702	27,880	4.528	1.201	3													
2.953	2.165	2.559	22,127	34,960	5.433	1.280	4													
3.150	2.362	2.756	28,322	40,713	5.709	1.280	4													
3.346	2.559	2.953	42,484	65,496	6.102	1.535	8													
3.543	2.559	2.953	42,041	64,168	6.102	1.535	7													
3.937	2.756	3.150	61,070	79,657	6.693	1.732	10													
4.331	2.953	3.346	63,725	95,588	7.283	1.969	13													
4.528	3.150	3.543	65,496	98,243	7.402	1.969	12													
4.724	3.150	3.543	93,818	128,336	8.465	2.126	20													
4.921	3.346	3.740	97,358	132,761	8.465	2.126	18													
5.118	3.543	3.937	100,013	136,302	8.465	2.126	18													
5.512	3.740	4.134	133,646	177,900	9.055	2.382	22													
6.102	4.134	4.528	194,717	247,821	10.433	2.539	33													
6.299	4.331	4.724	200,027	254,902	10.433	2.539	32													
6.496	4.528	4.921	274,373	345,179	11.417	2.795	49													
6.693	4.724	5.118	282,339	354,915	11.417	2.795	46													
6.890	4.921	5.315	318,627	398,284	11.811	2.795	49													
7.087	5.118	5.512	327,478	409,790	11.811	2.795	46													
7.283	5.315	5.709	460,239	548,747	12.992	3.386	82													
7.480	5.512	5.906	473,515	564,678	12.992	3.386	79													
7.677	5.512	6.102	575,299	721,336	13.780	3.386	90													
7.874	5.906	6.299	654,956	761,165	13.780	3.386	90													
8.661	6.299	6.693	840,821	973,583	14.567	4.094	119													
9.449	6.693	7.480	1,062,090	1,380,717	15.945	4.291	148													

Identified selections meet minimum bore, maximum bore and are equal to or greater than coupling size peak overload torque rating. TLK 622 is available for applications where installation of the shrink disc without torque wrenches is desired.

The XTSRLS52 couplings are an all-purpose high-torque coupling used where minimum coupling weight is desirable at longer coupling spans. Optimized design and construction include stainless disc packs. An optional one size larger LH hub, two sizes larger XL hub, or three sizes larger XXL hub is available with adapter to increase bore capacity.

The XTSRLS52 couplings are API 610, ISO 10441, ISO 14691 compliant when specified, and ATEX II 2GD c T6 certified. Common applications include motor and turbine driven compressors, fans, synchronized rollers, wire feeders and blowers.

Construction

Hubs and Center assembly: Carbon steel with welded carbon steel tube

Bolts: Alloy steel

Disc Packs: Stainless steel. Max misalignment is 1/2° per disc pack for sizes 726-996,
and 1/3° per disc pack for sizes 1088-4588.

Coatings Available: Consult Rexnord

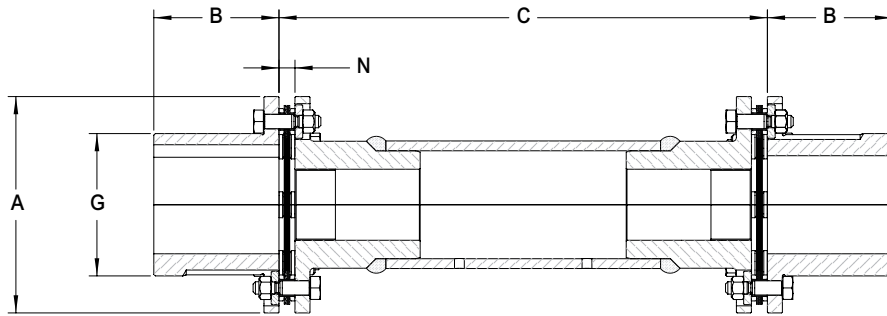

STANDARD HUB (WITHOUT ADAPTER)



WITHOUT ADAPTER

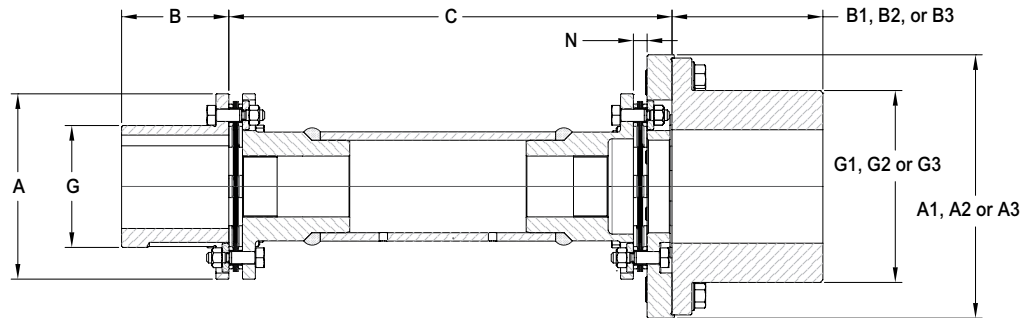

WITH ADAPTER AND LARGE HUB



WITH ADAPTER

Example Selection:

1. Select coupling size 1088 for a 19,000 lb-in torque and 2.5 in pump shaft diameter.
2. Select XXL 2nd hub for 3.5 in motor shaft diameter.
3. Operation speed is 1,800 rpm.
4. DBSE is 78.75 in.
5. Therefore, coupling is a 1088 XTSRLS52 XXL to accommodate long span need.

A 1088 XTSRLS52 XXL has one hub with 2.5in max bore and one hub with 4in max bore. The max DBSE without an adapter is 87 in at 1,800 rpm.

General Coupling Data

Size	④ Max. Cont. Torque (lb•in)	③ Std Hub Max. Bore	③ LH Hub Max. Bore	③ XL Hub Max. Bore	③ XXL Hub Max. Bore	⑤ Min. C (in)	Min. C with Adapter (in)	① Axial Capac- ity (in)	N (in)	② WR2 (lb•in ²)	② Std Weight (lb)	Weight Change Per in of "C" (lb/in)
726	2,630	1.75	—	2.00	2.38	14.68	15.17	±0.05	0.339	9.11	6.60	0.119
826	4,900	2.00	—	2.38	2.88	14.74	15.33	±0.06	0.368	21.6	12.1	0.264
996	8,210	2.25	2.38	2.88	3.38	30.76	31.51	±0.07	0.378	55.1	22.1	0.320
1088	19,400	2.50	2.88	3.38	4.00	30.82	31.56	±0.05	0.408	114	42.8	0.667
1298	31,400	3.00	3.38	4.00	4.50	31.02	31.92	±0.06	0.508	254	62.7	0.834
1548	52,300	3.50	4.00	4.50	5.00	31.16	32.23	±0.07	0.582	518	86.0	1.00
1698	72,500	4.00	4.50	5.00	5.50	31.24	32.47	±0.08	0.622	807	107	1.11
1928	98,200	4.50	5.00	5.50	6.00	31.34	32.63	±0.09	0.672	1,350	135	1.28
2068	136,000	4.75	5.50	6.00	6.50	31.45	32.99	±0.10	0.725	2,110	196	1.96
2278	176,000	5.38	6.00	6.50	7.75	31.51	33.10	±0.11	0.755	3,360	253	2.21
2468	232,000	5.75	6.50	7.75	8.63	31.61	33.31	±0.12	0.807	4,690	295	2.38
2698	318,000	6.00	7.75	8.63	9.13	43.85	45.76	±0.13	0.924	8,150	443	3.44
2888	416,000	6.75	8.63	9.13	10.00	43.98	46.03	±0.14	0.991	11,600	538	3.67
3058	461,000	7.13	9.13	10.00	11.00	43.98	46.05	±0.15	0.991	15,200	616	4.00
3358	622,000	8.00	10.00	11.00	11.50	44.15	46.48	±0.16	1.076	25,000	891	5.40
3668	834,000	8.88	11.00	11.50	12.25	44.39	46.86	±0.17	1.196	38,800	1,130	5.98
3908	909,000	9.50	11.50	12.25	14.00	44.39	46.89	±0.19	1.196	52,500	1,390	7.67
4178	1,130,000	10.13	12.25	14.00	15.00	44.55	47.31	±0.20	1.277	71,400	1,430	8.17
4588	1,670,000	11.00	14.00	15.00	16.00	40.83	43.98	±0.22	1.415	115,000	2,180	10.9

Size	Std A (in)	LH A1 (in)	XL A2 (in)	XXL A3 (in)	Std B (in)	LH B1 (in)	XL B2 (in)	XXL B3 (in)	Std G (in)	LH G1 (in)	XL G2 (in)	XXL G3 (in)
726	3.74	—	4.25	5.08	1.18	—	1.65	2.01	2.51	—	2.87	3.39
826	4.25	—	5.08	5.51	1.97	—	2.01	3.23	2.83	—	3.39	4.09
996	5.08	5.08	5.51	6.54	1.97	2.01	3.23	3.74	3.32	3.39	4.09	4.84
1088	5.51	5.51	6.54	7.83	3.19	3.23	3.74	4.49	3.63	4.09	4.84	5.71
1298	6.54	6.54	7.83	8.66	3.82	3.74	4.49	4.80	4.35	4.84	5.71	6.50
1548	7.76	7.83	8.66	9.66	3.82	4.49	4.80	5.31	5.21	5.71	6.50	7.17
1698	8.58	8.66	9.66	10.39	4.33	4.80	5.31	6.10	5.78	6.50	7.17	7.87
1928	9.65	9.66	10.39	11.44	4.33	5.31	6.10	6.57	6.60	7.17	7.87	8.66
2068	10.39	10.39	11.44	12.32	4.92	6.10	6.57	7.48	7.03	7.87	8.66	9.29
2278	11.46	11.44	12.32	13.58	5.71	6.57	7.48	7.28	7.74	8.66	9.29	11.02
2468	12.32	12.32	13.58	15.00	5.91	7.48	7.28	7.87	8.41	9.29	11.02	12.13
2698	13.50	13.58	15.00	15.94	5.91	7.28	7.87	7.52	9.14	11.02	12.13	13.07
2888	14.61	15.00	15.94	17.20	6.89	7.87	7.52	8.86	9.69	12.13	13.07	13.98
3058	15.55	15.94	17.20	18.98	7.28	7.52	8.86	10.12	10.35	13.07	13.98	15.67
3358	16.81	17.20	18.98	19.80	9.65	8.86	10.12	9.80	11.34	13.98	15.67	16.50
3668	18.35	18.98	19.80	20.83	11.06	10.12	9.80	10.47	12.41	15.67	16.50	17.48
3908	19.29	19.80	20.83	23.94	11.93	9.80	10.47	11.81	13.35	16.50	17.48	19.84
4178	20.63	20.83	23.94	25.51	12.68	10.47	11.81	12.60	14.22	17.48	19.84	21.46
4588	23.11	23.94	25.51	26.69	13.78	11.81	12.60	13.62	15.44	19.84	21.46	22.64

- ① All Thomas disc couplings meet NEMA frame sleeve bearing motor specifications without modification or the addition of end-float restricting devices.
- ② Weight and WR² of couplings with standard adapters at maximum bore and minimum "C" dimension listed.
- ③ Consult Rexnord for minimum rough bore sizes.
- ④ Peak Overload Torque (lb • in) is twice the Maximum Continuous Torque.
- ⑤ If shorter C lengths are required than the listed minimums, refer to XTSR52 page.

Maximum C (Without Adapter) at Given rpm (in)

Size	3,600 rpm	3,000 rpm	1,800 rpm	1,500 rpm	1,200 rpm	1,000 rpm	900 rpm	750 rpm	720 rpm	600 rpm	500 rpm
726	51	56	72	79	88	96	101	111	113	124	136
826	54	60	77	84	94	103	109	119	122	133	146
996	60	66	85	93	104	114	120	131	134	147	161
1088	61	67	87	95	106	116	123	134	137	150	164
1298	68	75	97	106	119	130	137	150	153	168	184
1548	75	82	106	116	130	142	150	164	168	184	201
1698	79	87	112	122	137	150	158	173	177	194	212
1928	85	93	120	131	147	161	169	186	189	208	227
2068	86	94	121	133	148	163	171	188	192	210	230
2278	91	100	129	141	158	173	182	199	203	223	244
2468	94	103	133	146	163	179	189	207	211	231	253
2698	98	108	139	152	170	187	197	216	220	241	264
2888	102	111	144	157	176	193	203	222	227	249	272
3058	106	116	150	164	184	201	212	232	237	260	285
3358	110	120	155	170	190	208	219	240	245	269	294
3668	115	126	163	178	200	219	230	252	258	282	309
3908	120	131	170	186	208	228	240	263	268	294	322
4178	124	136	175	192	214	235	247	271	277	303	332
4588	128	140	181	198	221	243	256	280	286	313	343

NOTE: Consult Rexnord for intended applications at speeds not covered in the table.

Component Part Numbers

Size	① Standard Hub	② LH Hub + Cap Screw Kit	② XL Hub + Cap Screw Kit	② XXL Hub + Cap Screw Kit	⑤ Adapters			③ Disc Pack Hardware Kit	④ Disc Pack
					LH Part No.	XL Part No.	XXL Part No.		
726	10001191	10001611	10001612	10001613	10000241	10001161	10002621	10001561	10000091
826	10001192	10001612	10001613	10001614	10000242	10001162	10002622	10001562	10000092
996	10001193	10001613	10001614	10001615	10000243	10001163	10002623	10001563	10000093
1088	10001194	10001614	10001615	10001616	10000244	10001164	10002624	10001564	10000094
1298	10001195	10001615	10001616	10001617	10000245	10001165	10002625	10001565	10000095
1548	10001196	10001616	10001617	10001618	10000246	10001166	10002626	10001566	10000096
1698	10001197	10001617	10001618	10001619	10000247	10001167	10002627	10001567	10000097
1928	10001198	10001618	10001619	10001620	10000248	10001168	10002628	10001568	10000098
2068	10001199	10001619	10001620	10001621	10000249	10001169	10002629	10001569	10000099
2278	10001200	10001620	10001621	10001622	10000250	10001170	10002630	10001570	10000100
2468	10001201	10001621	10001622	10001623	10000251	10001171	10002631	10001571	10000101
2698	10001202	10001622	10001623	10001624	10000252	10001172	10002632	10001572	10000102
2888	10001203	10001623	10001624	10001631	10000253	10001173	10002633	10001573	10000103
3058	10001204	10001624	10001631	10001625	10000254	10001174	10002634	10001574	10000104
3358	10001205	10001631	10001625	10001626	10000255	10001175	10002635	10001575	10000105
3668	10001206	10001625	10001626	10001627	10000256	10001176	10002636	10001576	10000106
3908	10001207	10001626	10001627	10001628	10000257	10001177	10002637	10001577	10000107
4178	10001208	10001627	10001628	10001629	10000258	10001178	10002638	10001578	10000108
4588	10001209	10001628	10001629	10001630	10000259	10001179	10002639	10001579	10000109



The XTSRLS71 couplings are designed for spacer type coupling critical applications including API applications. The optimized 3-piece design allows for the smallest possible package for an application. The hubs are pilot fitted to the factory assembled center member. The design allows for repeatable installations without special tooling. Additional modifications may be made to reduce coupling weight, or special mountings to make it an economical option on various critical and high speed applications. Additional engineered modifications available to provide unique application solutions.

The XTSRLS71 couplings are API 610 and ISO 14691 compliant when specified, compliant with API 671 (ISO 10441) when requested. ATEX II 2GD c T6 certified. Common applications include motor and turbine driven compressors, fans, synchronized rollers, wire feeders, generators and blowers.

Construction

- Hubs and Center assembly: Carbon steel with welded carbon steel tube
- Bolts: Alloy steel
- Disc Packs: Stainless steel. Max misalignment is 1/2° per disc pack for sizes 726-996, and 1/3° per disc pack for sizes 1088-4588.
- Coatings Available: Consult Rexnord

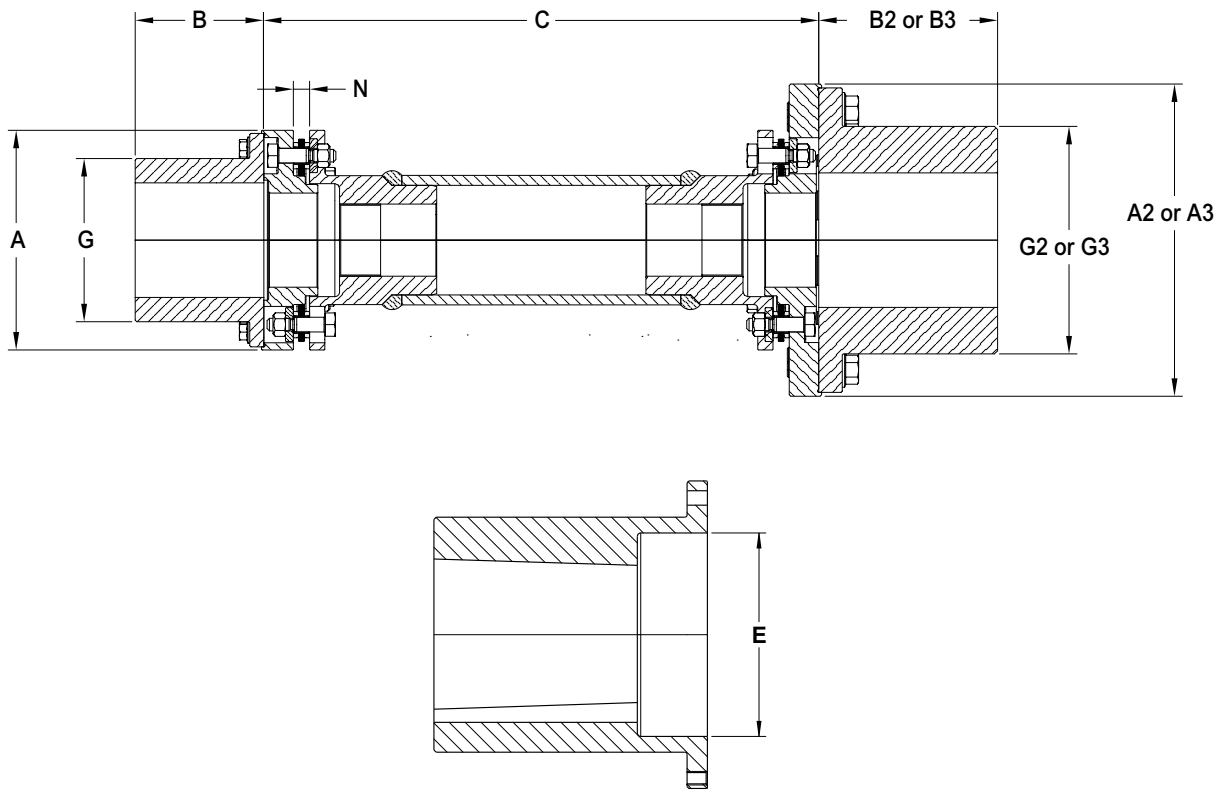

Example Selection:

1. Select coupling size 1088 for a 19,000 lb-in torque and 2.5 in pump shaft diameter.
2. Select XXL 2nd hub for 3.5 in motor shaft diameter.
3. Operation speed is 1,800 rpm.
4. DBSE is 78.75 in.
5. Therefore, coupling is a 1088 XTSRLS71 XXL to accommodate long span need.

A 1088 XTSRLS71 XXL has one hub with 2.88 in max bore and one hub with 4 in max bore. The max DBSE is 88 in at 1,800 rpm.

General Coupling Data

Size	④ Max. Cont. Torque (lb•in)	③ Std Hub Max. Bore	③ XL Hub Max. Bore	③ XXL Hub Max. Bore	⑤ Min. C (in)	① Axial Capacity (in)	Max Counter Bore E (in)
726	2,630	1.63	2.00	2.38	15.68	±0.05	2.08
826	4,900	2.00	2.38	2.88	15.89	±0.06	2.58
996	8,210	2.38	2.88	3.38	32.30	±0.07	3.03
1088	19,400	2.88	3.38	4.00	32.28	±0.05	3.47
1298	31,400	3.38	4.00	4.50	32.80	±0.06	4.13
1548	52,300	4.00	4.50	5.00	33.33	±0.07	4.86
1698	72,500	4.50	5.00	5.50	33.65	±0.08	5.60
1928	98,200	5.00	5.50	6.00	33.87	±0.09	6.17
2068	136,000	5.50	6.00	6.50	34.59	±0.10	6.70
2278	176,000	6.00	6.50	7.75	34.69	±0.11	7.42
2468	232,000	6.50	7.75	8.63	34.99	±0.12	7.85
2698	318,000	7.75	8.63	9.13	47.62	±0.13	9.69
2888	416,000	8.63	9.13	10.00	48.09	±0.14	10.69
3058	461,000	9.13	10.00	11.00	48.13	±0.15	11.73
3358	622,000	10.00	11.00	11.50	48.85	±0.16	12.37
3668	834,000	11.00	11.50	12.25	49.34	±0.17	13.97
3908	909,000	11.50	12.25	14.00	49.39	±0.19	14.85
4178	1,130,000	12.25	14.00	15.00	50.11	±0.20	15.64
4588	1,670,000	14.00	15.00	16.00	47.13	±0.22	17.72

Size	Std A (in)	XL A2 (in)	XXL A3 (in)	Std B (in)	XL B2 (in)	XXL B3 (in)	Std G (in)	XL G2 (in)	XXL G3 (in)	② Std Weight (lb)	Weight Change Per in of "C" (lb/in)	② WR2 (lb•in ²)
726	3.74	4.25	5.08	1.38	1.65	2.01	2.32	2.87	3.39	9.34	0.119	14.6
826	4.25	5.08	5.51	1.65	2.01	3.23	2.87	3.39	4.09	15.5	0.264	31.8
996	5.08	5.51	6.54	2.01	3.23	3.74	3.39	4.09	4.84	30.0	0.320	85.8
1088	5.51	6.54	7.83	3.23	3.74	4.49	4.09	4.84	5.71	51.0	0.667	156
1298	6.54	7.83	8.66	3.74	4.49	4.80	4.84	5.71	6.50	76.5	0.834	357
1548	7.83	8.66	9.66	4.49	4.80	5.31	5.71	6.50	7.17	114	1.000	788
1698	8.66	9.66	10.39	4.80	5.31	6.10	6.50	7.17	7.87	147	1.11	1,280
1928	9.66	10.39	11.44	5.31	6.10	6.57	7.17	7.87	8.66	189	1.28	2,110
2068	10.39	11.44	12.32	6.10	6.57	7.48	7.87	8.66	9.29	269	1.96	3,340
2278	11.44	12.32	13.58	6.57	7.48	7.28	8.66	9.29	11.02	341	2.21	5,170
2468	12.32	13.58	15.00	7.48	7.28	7.87	9.29	11.02	12.13	414	2.38	7,430
2698	13.58	15.00	15.94	7.28	7.87	7.52	11.02	12.13	13.07	599	3.44	13,200
2888	15.00	15.94	17.20	7.87	7.52	8.86	12.13	13.07	13.98	764	3.67	20,200
3058	15.94	17.20	18.98	7.52	8.86	10.12	13.07	13.98	15.67	856	4.00	26,100
3358	17.20	18.98	19.80	8.86	10.12	9.80	13.98	15.67	16.50	1,140	5.40	40,200
3668	18.98	19.80	20.83	10.12	9.80	10.47	15.67	16.50	17.48	1,530	5.98	66,600
3908	19.80	20.83	23.94	9.80	10.47	11.81	16.50	17.48	19.84	1,720	7.67	82,000
4178	20.83	23.94	25.51	10.47	11.81	12.60	17.48	19.84	21.46	2,010	8.17	109,000
4588	23.94	25.51	26.69	11.81	12.60	13.62	19.84	21.46	22.64	2,890	10.9	199,000

- ① All Thomas disc couplings meet NEMA frame sleeve bearing motor specifications without modification or the addition of end-float restricting devices.
- ② Weight and WR² of couplings with standard adapters at maximum bore and minimum "C" dimension listed.
- ③ Consult Rexnord for minimum rough bore sizes.
- ④ Peak Overload Torque (lb•in) is twice the Maximum Continuous Torque.
- ⑤ If shorter C lengths are required than the listed minimums, refer to XTSR71 page.

Maximum C at Given rpm (in)*

Size	3,600 rpm	3,000 rpm	1,800 rpm	1,500 rpm	1,200 rpm	1,000 rpm	900 rpm	750 rpm	720 rpm	600 rpm	500 rpm
726	52	57	73	80	89	97	102	112	114	125	137
826	56	61	78	86	96	105	110	121	123	135	147
996	61	67	86	94	105	115	121	133	135	148	162
1088	63	69	88	96	108	118	124	136	139	152	166
1298	70	77	99	108	120	132	139	152	155	170	186
1548	77	84	108	118	132	144	152	166	170	186	203
1698	81	89	114	125	139	152	161	176	179	196	215
1928	87	95	122	134	149	163	172	188	192	210	230
2068	89	97	124	136	152	166	174	191	195	213	233
2278	94	103	132	144	161	176	185	203	207	226	247
2468	98	107	137	150	167	182	192	210	214	234	257
2698	102	112	143	156	174	191	201	219	224	245	268
2888	106	115	148	161	180	197	207	227	231	253	277
3058	110	120	154	168	188	205	216	236	241	264	289
3358	114	125	160	175	195	213	224	245	250	273	299
3668	120	131	168	183	204	224	235	257	263	287	314
3908	125	136	175	191	213	233	245	268	273	299	327
4178	129	141	181	197	220	240	253	277	282	309	338
4588	134	146	187	204	228	249	262	286	292	319	349

* For API-671 required couplings, consult Rexnord for maximum spans.

NOTE: Consult Rexnord for intended applications at speeds not covered in the table.

Component Part Numbers

Size	① Standard Hub + Cap Screw Kit	XL Hub + Cap Screw Kit	② Standard Adapter	XL Adapter	XXL Adapter	③ Disc Pack Hardware Kit	④ Disc Pack
726	10001611	10001612	10001131	10001781	10002805	10001561	10000091
826	10001612	10001613	10001132	10001782	10002806	10001562	10000092
996	10001613	10001614	10001133	10001783	10002807	10001563	10000093
1088	10001614	10001615	10001134	10001784	10002808	10001564	10000094
1298	10001615	10001616	10001135	10001785	10002809	10001565	10000095
1548	10001616	10001617	10001136	10001786	10002810	10001566	10000096
1698	10001617	10001618	10001137	10001787	10002811	10001567	10000097
1928	10001618	10001619	10001138	10001788	10002812	10001568	10000098
2068	10001619	10001620	10001139	10001789	10002813	10001569	10000099
2278	10001620	10001621	10001140	10001790	10002814	10001570	10000100
2468	10001621	10001622	10001141	10001791	10002815	10001571	10000101
2698	10001622	10001623	10001142	10001792	10002816	10001572	10000102
2888	10001623	10001624	10001143	10001793	10002817	10001573	10000103
3058	10001624	10001631	10001144	10001794	10002818	10001574	10000104
3358	10001631	10001625	10001145	10001795	10002819	10001575	10000105
3668	10001625	10001626	10001146	10001796	10002820	10001576	10000106
3908	10001626	10001627	10001147	10001797	10002821	10001577	10000107
4178	10001627	10001628	10001148	10001798	10002822	10001578	10000108
4588	10001628	10001629	10001149	10001799	10002823	10001579	10000109

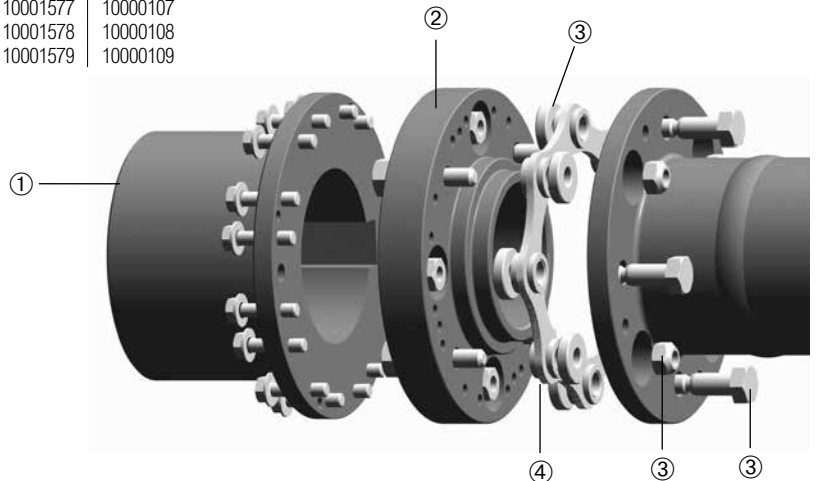

Replaces troublesome gear couplings on pulp and paper applications. The Thomas one-piece, factory-torqued assembly is easy to install. This coupling is designed to bolt directly to existing rigid hubs using the gear coupling bolts. Axial shims are supplied for minor axial positioning adjustment.

Construction

Hubs and Center assembly: Carbon steel

Bolts: Alloy steel

Disc Packs: Stainless steel. Max misalignment is 1/2° per disc pack for size 996 and 1/3° per disc pack for sizes 1088-4178.

Coatings Available: Consult Rexnord

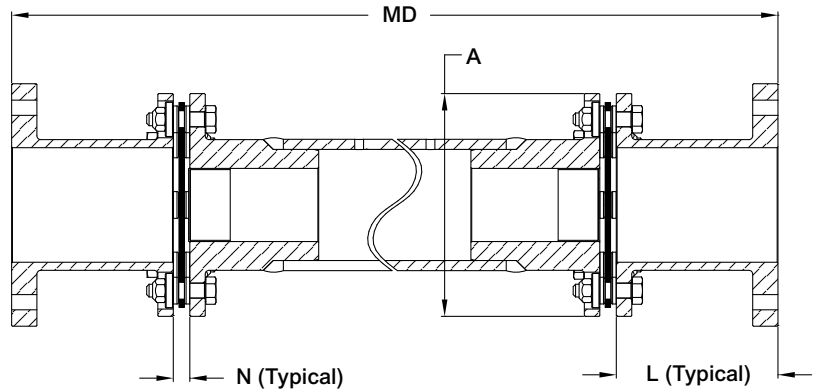

General Coupling Data

For maximum centermember lengths per application speeds and coupling size, consult Rexnord.

Gear Coupling (Falk) Thomas Coupling	#1½ (1015)	#2 (1020)	#2½ (1025)	#3 (1030)	#3½ (1035)	#4 (1040)	#4½ (1045)	#5 (1050)	#5½ (1055)	#6 (1060)	#7 (1070)
	996										
1088											
1298											
1548											
1698											
1928											
2068											
2278											
2468											
2698											
2888											
3058											
3358											
3668											
3908											
4178											

Available In These Sizes

Size	Max. Horsepower per 100 RPM	Max. Continuous Torque (lb-in)	Peak Overload Torque (lb-in) ②	A (in)	L (in)	Min. Mounting Dimension "MD" (in)	N (in)	Axial Capacity (in) ①
	Service Factor 1.0							
996	13.0	8,210	16,420	5.08	4.00	38.76	0.38	±0.07
1088	30.8	19,400	38,800	5.51	4.00	38.82	0.41	±0.05
1298	49.8	31,400	62,800	6.54	5.13	41.27	0.51	±0.06
1548	83.0	52,300	104,600	7.76	5.50	42.16	0.58	±0.07
1698	115	72,500	145,000	8.58	6.63	44.49	0.62	±0.08
1928	156	98,200	196,400	9.65	6.50	44.34	0.67	±0.09
2068	216	136,000	272,000	10.39	6.75	44.95	0.73	±0.10
2278	279	176,000	352,000	11.46	7.25	46.01	0.75	±0.11
2468	368	232,000	464,000	12.32	7.75	47.11	0.81	±0.12
2698	505	318,000	636,000	13.50	9.13	62.10	0.92	±0.13
2888	660	416,000	832,000	14.61	9.13	62.23	0.99	±0.14
3058	731	461,000	922,000	15.55	9.13	62.23	0.99	±0.15
3358	987	622,000	1,244,000	16.81	9.25	62.65	1.08	±0.16
3668	1,323	834,000	1,668,000	18.35	9.75	63.89	1.20	±0.17
3908	1,442	909,000	1,818,000	19.29	10.25	64.89	1.20	±0.19
4178	1,793	1,130,000	2,260,000	20.63	10.25	65.05	1.28	±0.20

① All Thomas disc couplings meet NEMA frame sleeve bearing motor specifications without modification or the addition of end-float restricting devices.

② The peak overload torque is not an alternating torque limit.

Optimized design and construction include stainless disc pack and corrosion protection; additional modifications may be made to reduce coupling weight, or special mountings to make alternative to high performance styles. Common engineered solutions are available such as spark resistant, and alloy construction. An optional one size larger LH hub, two sizes larger or three sizes larger XXL hub is available with adapter to increase bore capacity.

The XTSRS single couplings are XL hub, an all-purpose high-speed, high-torque coupling used where minimum coupling weight is desirable. ATEX II 2GD c T6 certified. Common applications include units where one shaft is fully supported in its own bearings and the other shaft is single bearing supported. The radial load is transmitted through the coupling to the inner bearing of the other shaft.

Construction

Hubs and Center assembly: Carbon steel

Bolts: Alloy steel

Disc Packs: Stainless steel. Max misalignment is 2/3° per disc pack for sizes 494 & 644,
1/2° per disc pack for sizes 726-996, and 1/3° per disc pack for sizes 1088-5258.

Coatings Available: Manganese Phosphate provided as standard. Other coatings available upon request.

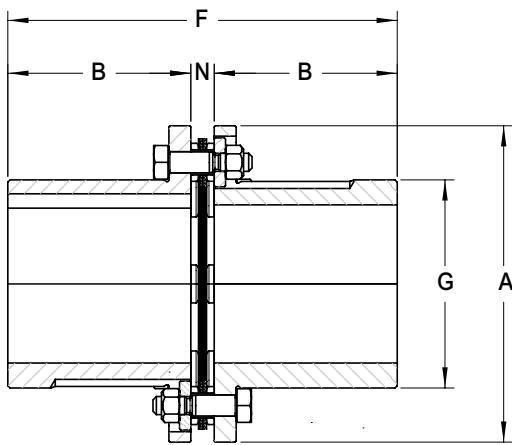

STANDARD HUB (WITHOUT ADAPTER)

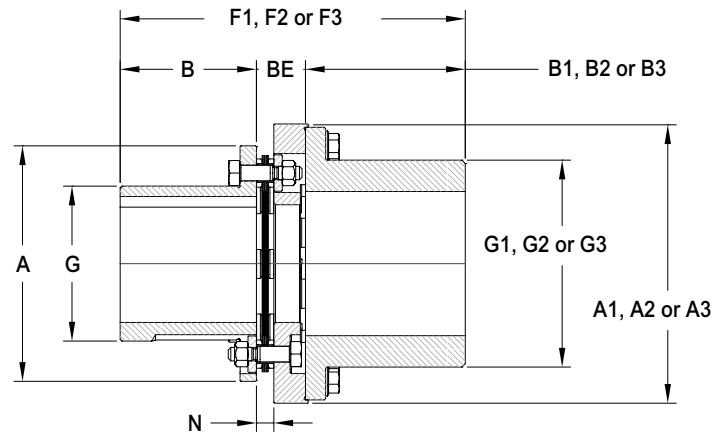

WITH ADAPTER AND LARGE HUB

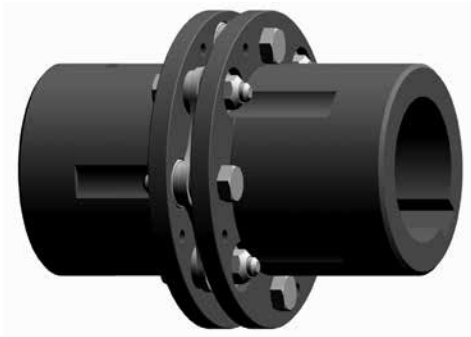

WITHOUT ADAPTER

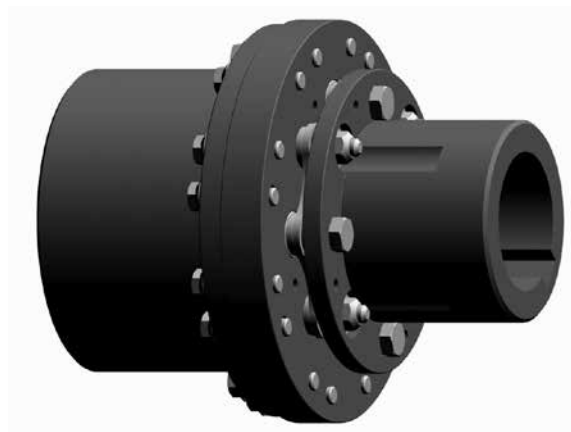

WITH ADAPTER

Example Selection:

1. Select coupling size 1088 for 19,000 lb-in torque and 2.5 in pump shaft diameter.
2. Select XXL 2nd hub for 3.5 in motor shaft diameter.
3. Therefore, coupling is a 1088 XTSRS XXL.

A 1088 XTSRS XXL has one hub with 2.5 in max bore and one hub with 4 in max bore.

General Coupling Data

Size	⑤ Max. Cont. Torque (lb•in)	③ Std Hub Max. Bore	③ LH Hub Max. Bore	③ XL Hub Max. Bore	③ XXL Hub Max. Bore	Max. Speed (rpm)	① Axial Capacity (in)	N (in)	BE (in)	Std F (in)	LH F1 (in)	XL F2 (in)	XXL F2 (in)	② Std Weight (lb)
494	750	1.00	1.13	1.50	1.63	13,800	±0.02	0.339	0.819	1.92	2.39	2.59	2.99	1.06
644	1,280	1.50	1.50	—	2.00	12,500	±0.03	0.339	0.863	2.30	2.83	—	3.50	1.74
726	2,630	1.75	—	2.00	2.38	12,000	±0.03	0.339	0.831	2.70	—	3.67	4.02	2.72
826	4,900	2.00	—	2.38	2.88	10,900	±0.03	0.368	0.962	4.30	4.58	4.94	6.16	5.26
996	8,210	2.25	2.38	2.88	3.38	9,800	±0.04	0.378	1.130	4.31	5.11	6.33	6.84	8.24
1088	19,400	2.50	2.88	3.38	4.00	9,000	±0.03	0.408	1.148	6.79	7.57	8.08	8.83	14.4
1298	31,400	3.00	3.38	4.00	4.50	8,000	±0.03	0.508	1.410	8.15	8.97	9.72	10.03	24.7
1548	52,300	3.50	4.00	4.50	5.00	7,100	±0.04	0.582	1.649	8.22	9.96	10.27	10.78	37.9
1698	72,500	4.00	4.50	5.00	5.50	6,600	±0.04	0.622	1.846	9.28	10.98	11.49	12.28	50.0
1928	98,200	4.50	5.00	5.50	6.00	6,100	±0.05	0.672	1.960	9.33	11.61	12.39	12.87	67.4
2068	136,000	4.75	5.50	6.00	6.50	5,800	±0.05	0.725	2.269	10.57	13.29	13.76	14.67	89.9
2278	176,000	5.38	6.00	6.50	7.75	5,500	±0.05	0.755	2.349	12.17	14.63	15.54	15.34	119
2468	232,000	5.75	6.50	7.75	8.63	5,200	±0.06	0.807	2.500	12.62	15.89	15.69	16.28	150
2698	318,000	6.00	7.75	8.63	9.13	4,800	±0.06	0.924	2.833	12.73	16.02	16.61	16.26	196
2888	416,000	6.75	8.63	9.13	10.00	4,600	±0.07	0.991	3.038	14.77	17.80	17.45	18.79	245
3058	461,000	7.13	9.13	10.00	11.00	4,400	±0.07	0.991	3.054	15.56	17.86	19.20	20.46	288
3358	622,000	8.00	10.00	11.00	11.50	4,200	±0.08	1.076	3.403	20.37	21.91	23.17	22.85	415
3668	834,000	8.88	11.00	11.50	12.25	3,900	±0.09	1.196	3.668	23.32	24.85	24.53	25.20	553
3908	909,000	9.50	11.50	12.25	14.00	3,800	±0.09	1.196	3.692	25.05	25.42	26.09	27.43	658
4178	1,130,000	10.13	12.25	14.00	15.00	3,600	±0.10	1.277	4.033	26.63	27.18	28.52	29.31	604
4588	1,670,000	11.00	14.00	15.00	16.00	3,400	±0.11	1.415	4.565	28.97	30.16	30.94	31.97	1,080
4918	2,080,000	11.75	15.00	16.00	—	3,200	±0.12	1.501	4.800	31.03	32.16	33.19	—	1,340
5258	2,510,000	12.63	16.00	—	—	3,100	±0.12	1.586	5.153	33.16	34.56	—	—	1,630

Size	Std A (in)	LH A1 (in)	XL A2 (in)	XXL A3 (in)	Std B (in)	LH B1 (in)	XL B2 (in)	XXL B3 (in)	Std G (in)	LH G1 (in)	XL G2 (in)	XXL G3 (in)	② WR2 (lb•in ²)
494	2.76	2.77	3.36	3.74	0.79	0.79	0.98	1.38	1.61	1.65	2.28	2.32	0.889
644	3.35	3.36	—	4.25	0.98	0.98	—	1.65	2.20	2.28	—	2.87	2.21
726	3.74	—	4.25	5.08	1.18	—	1.65	2.01	2.51	—	2.87	3.39	4.23
826	4.25	—	5.08	5.51	1.97	—	2.01	3.23	2.83	—	3.39	4.09	10.3
996	5.08	5.08	5.51	6.54	1.97	2.01	3.23	3.74	3.32	3.39	4.09	4.84	22.4
1088	5.51	5.51	6.54	7.83	3.19	3.23	3.74	4.49	3.63	4.09	4.84	5.71	45.5
1298	6.54	6.54	7.83	8.66	3.82	3.74	4.49	4.80	4.35	4.84	5.71	6.50	111
1548	7.76	7.83	8.66	9.66	3.82	4.49	4.80	5.31	5.21	5.71	6.50	7.17	244
1698	8.58	8.66	9.66	10.39	4.33	4.80	5.31	6.10	5.78	6.50	7.17	7.87	398
1928	9.65	9.66	10.39	11.44	4.33	5.31	6.10	6.57	6.60	7.17	7.87	8.66	694
2068	10.39	10.39	11.44	12.32	4.92	6.10	6.57	7.48	7.03	7.87	8.66	9.29	1,060
2278	11.46	11.44	12.32	13.58	5.71	6.57	7.48	7.28	7.74	8.66	9.29	11.02	1,720
2468	12.32	12.32	13.58	15.00	5.91	7.48	7.28	7.87	8.41	9.29	11.02	12.13	2,530
2698	13.50	13.58	15.00	15.94	5.91	7.28	7.87	7.52	9.14	11.02	12.13	13.07	3,930
2888	14.61	15.00	15.94	17.20	6.89	7.87	7.52	8.86	9.69	12.13	13.07	13.98	5,880
3058	15.55	15.94	17.20	18.98	7.28	7.52	8.86	10.12	10.35	13.07	13.98	15.67	7,670
3358	16.81	17.20	18.98	19.80	9.65	8.86	10.12	9.80	11.34	13.98	15.67	16.50	12,900
3668	18.35	18.98	19.80	20.83	11.06	10.12	9.80	10.47	12.41	15.67	16.50	17.48	20,800
3908	19.29	19.80	20.83	23.94	11.93	9.80	10.47	11.81	13.35	16.50	17.48	19.84	27,500
4178	20.63	20.83	23.94	25.51	12.68	10.47	11.81	12.60	14.22	17.48	19.84	21.46	38,400
4588	23.11	23.94	25.51	26.69	13.78	11.81	12.60	13.62	15.44	19.84	21.46	22.64	63,500
4918	24.80	25.51	26.69	—	14.76	12.60	13.62	—	16.55	21.46	22.64	—	90,600
5258	26.46	25.51	—	—	15.79	—	—	—	17.70	—	—	—	126,000

- ① All Thomas disc couplings meet NEMA frame sleeve bearing motor specifications without modification or the addition of end-float restricting devices.
- ② Weight and WR² of couplings with standard adapters at maximum bore and minimum "C" dimension listed.
- ③ Consult Rexnord for minimum rough bore sizes.
- ④ XTSRS single couplings meet AGMA Class 9 balance requirements as manufactured with interference fit bore and close fit keyway. If clearance fit and/or setscrews are required, consult Rexnord.
- ⑤ Peak Overload Torque (lb • in) is twice the Maximum Continuous Torque.

Component Part Numbers

Size	① Standard Hub	⑤ LH Hub + Cap Screw Kit	⑤ XL Hub + Cap Screw Kit	⑤ XXL Hub + Cap Screw Kit	Adapters ④			② Disc Pack Hardware Kit	③ Disc Pack
					LH Part No.	XL Part No.	XXL Part No.		
494	10003201	10611141	10611142	10001611	10003209	10003210	10003211	10611144	10003753
644	10003202	10611142	—	10001612	10003212	—	10003214	10611145	10002803
726	10001191	10001611	10001612	10001613	10000241	10001161	10002621	10001561	10000091
826	10001192	10001612	10001613	10001614	10000242	10001162	10002622	10001562	10000092
996	10001193	10001613	10001614	10001615	10000243	10001163	10002623	10001563	10000093
1088	10001194	10001614	10001615	10001616	10000244	10001164	10002624	10001564	10000094
1298	10001195	10001615	10001616	10001617	10000245	10001165	10002625	10001565	10000095
1548	10001196	10001616	10001617	10001618	10000246	10001166	10002626	10001566	10000096
1698	10001197	10001617	10001618	10001619	10000247	10001167	10002627	10001567	10000097
1928	10001198	10001618	10001619	10001620	10000248	10001168	10002628	10001568	10000098
2068	10001199	10001619	10001620	10001621	10000249	10001169	10002629	10001569	10000099
2278	10001200	10001620	10001621	10001622	10000250	10001170	10002630	10001570	10000100
2468	10001201	10001621	10001622	10001623	10000251	10001171	10002631	10001571	10000101
2698	10001202	10001622	10001623	10001624	10000252	10001172	10002632	10001572	10000102
2888	10001203	10001623	10001624	10001631	10000253	10001173	10002633	10001573	10000103
3058	10001204	10001624	10001631	10001625	10000254	10001174	10002634	10001574	10000104
3358	10001205	10001631	10001625	10001626	10000255	10001175	10002635	10001575	10000105
3668	10001206	10001625	10001626	10001627	10000256	10001176	10002636	10001576	10000106
3908	10001207	10001626	10001627	10001628	10000257	10001177	10002637	10001577	10000107
4178	10001208	10001627	10001628	10001629	10000258	10001178	10002638	10001578	10000108
4588	10001209	10001628	10001629	10001630	10000259	10001179	10002639	10001579	10000109
4918	10001210	10001629	10001630	—	10000260	10001180	—	10001580	10000110
5258	10001211	10001630	—	—	10000261	—	—	10001581	10000111

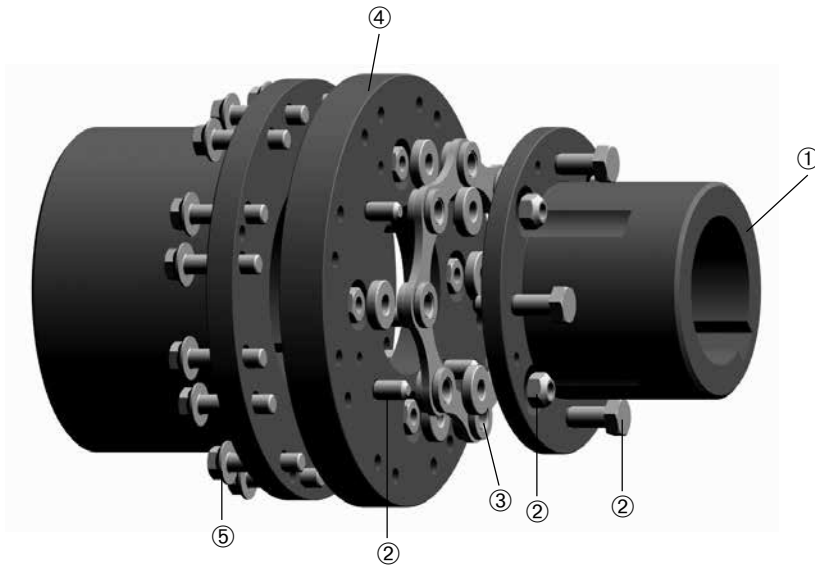

AMR couplings are used in heavy-duty, slow to medium speed applications, where high-starting torque, shock loads, torque reversals or continuous alternating torque are present. The open lug type center member provides ample clearance for assembly while minimizing the space required for coupling installation.

Construction

Hubs: Sizes 162 - 550 are carbon steel with integral washer, sizes 600 and larger are carbon steel with separate grooved washer

Center Member: Sizes 162 - 750 are cast alloy iron, sizes 800 and larger are cast steel

Bolts: Alloy steel

Disc Packs: Tomaloy Tpack (sizes 225 - 750)

Coatings Available: Consult Renord

Other disc pack materials such as stainless steel, Monel and Inconel are available; please consult Renord.

Misalignment: 1/3° per disc pack

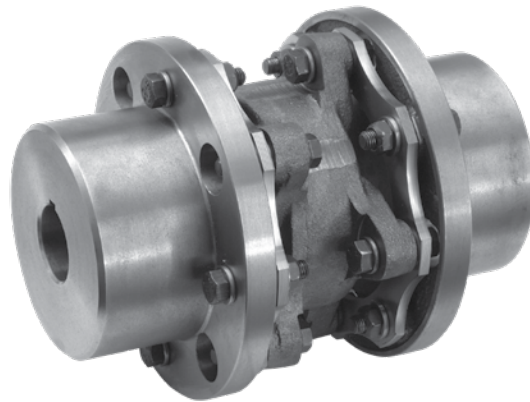
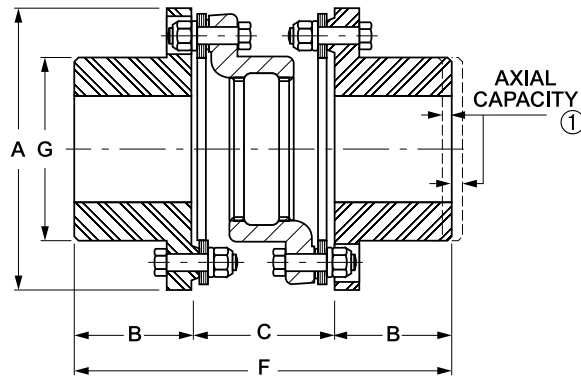

General Dimensions (in)

Coupling Size	④ Rough Bore	⑥ Max. Bore	A	B	C	F	G	⑨ Min. Shaft Length H
162	—	1.88	4.56	1.75	2.64	6.14	2.75	1.34
200	—	2.25	5.75	2.12	2.99	7.23	3.62	1.58
225	—	2.63	6.00	2.50	2.99	7.99	3.88	1.97
262	—	3.13	6.88	2.88	3.51	9.27	4.50	2.26
312	—	3.63	8.12	3.38	4.14	10.90	5.44	2.63
350	—	4.00	9.12	3.75	4.58	12.08	6.00	2.91
375	—	4.50	10.06	4.00	5.18	13.18	6.50	3.13
425	—	4.75	11.00	4.25	5.55	14.05	7.00	3.25
450	—	5.13	11.88	4.50	5.93	14.93	7.44	3.44
500	2.69	5.38	13.44	5.00	6.81	16.81	8.38	3.81
550	2.69	6.00	15.00	5.50	7.70	18.70	9.44	4.19
600	3.69	6.50	16.75	6.00	8.43	20.43	10.31	4.57
700	4.25	7.50	18.94	7.00	9.66	23.66	11.75	5.32
750	4.94	8.00	20.62	7.25	10.54	25.04	12.62	5.5
800	5.19	8.75	22.38	7.75	11.36	26.86	13.75	5.81
850	5.44	9.25	23.75	8.25	12.18	28.68	14.50	6.12
925	5.94	10.12	25.75	9.00	13.25	31.25	15.88	6.75
1000	6.50	11.00	28.25	9.50	14.48	33.48	17.50	7.19
1100	7.00	12.00	30.25	10.25	15.50	36.00	18.50	7.81
1200	7.50	13.00	33.38	11.00	17.06	39.06	20.25	—
1300	8.00	14.00	36.00	12.00	18.31	42.31	22.50	—
1550	8.50	15.50	39.25	14.50	19.44	48.44	26.00	—

Coupling Size	Max. Horsepower per 100 RPM	③ Max. RPM	Max. Continuous Torque (lb-in)	⑦ Peak Overload Torque (lb-in)	② Weight (lb)	② ⑤ WR ² (lb-in ²)	① Axial Capacity (in)
	Service Factor 1.0						
162	9.1	2,500	5,740	6,888	8	18	±0.036
200	17.5	2,500	11,030	13,236	16	57	±0.036
225	24.7	2,500	15,575	18,690	20	76	±0.036
262	33.4	2,500	21,038	25,245	32	162	±0.043
312	37.5	2,500	23,650	28,380	47	365	±0.051
350	83.8	2,300	52,800	63,360	71	659	±0.056
375	126	2,200	79,442	95,330	92	1,025	±0.062
425	140	2,000	88,000	105,600	117	1,590	±0.067
450	216	1,900	136,125	163,350	144	2,250	±0.072
500	319	1,800	200,750	240,900	212	4,240	±0.082
550	436	1,800	275,055	330,066	290	7,220	±0.092
600	569	1,800	358,875	430,650	389	12,000	±0.102
700	724	1,500	456,500	547,800	587	22,800	±0.115
750	1,023	1,500	644,930	773,916	722	33,900	±0.125
800	1,291	1,200	813,780	976,536	938	55,600	±0.136
850	1,426	1,100	898,700	1,078,440	1,150	75,600	±0.144
925	2,033	1,000	1,281,280	1,537,536	1,400	102,000	±0.156
1000	2,360	900	1,487,200	1,784,640	1,900	172,000	±0.172
1100	3,246	800	2,046,000	2,455,200	2,280	245,000	±0.183
1200	3,494	650	2,202,200	2,642,640	2,990	394,000	±0.203
1300	3,787	600	2,387,000	2,864,400	3,900	561,000	±0.218
1550	4,957	600	3,124,000	3,748,800	5,150	889,000	±0.242

- ① All Thomas disc couplings meet NEMA frame sleeve bearing motor specifications without modification or the addition of end-float restricting devices.
- ② Weight and WR² at maximum bore.
- ③ Consult Rexnord if balancing is required.
- ④ Consult Rexnord for minimum rough bore on size 162-450.
- ⑤ Special hub available for size 600 with 6 3/4 max. bore. Consult Rexnord.
- ⑥ Straight bores with no keyway require a special material hub. Consult Rexnord.
- ⑦ The peak overload torque is not an alternating torque limit.

CMR couplings are used in heavy-duty, slow to medium speed applications, where high-starting torque, shock loads, torque reversals or continuous alternating torque are present. The open lug type center member provides ample clearance for assembly while minimizing the space required for coupling installation.

The CMR couplings are designed with a flywheel adapter plate which bolts directly to the flywheel of an engine or compressor. The adapters are made to fit accurately into the recess in the flywheel, and external strains on the crankshaft resulting from the misalignment of the driven equipment is minimized.

Construction

Hubs: Sizes 162 - 550 are carbon steel with integral washer, sizes 600 and larger are carbon steel with separate grooved washer

Center Section: Sizes 162-750 are cast alloy iron, Sizes 800 and above are cast steel

Bolts: Alloy steel

Disc Packs: Tomaloy Tpack (225-750 size)

Coatings: Consult Rexnord

Other disc pack materials such as stainless steel, Monel and Inconel are available; please consult Rexnord.

Misalignment: 1/3° per disc pack

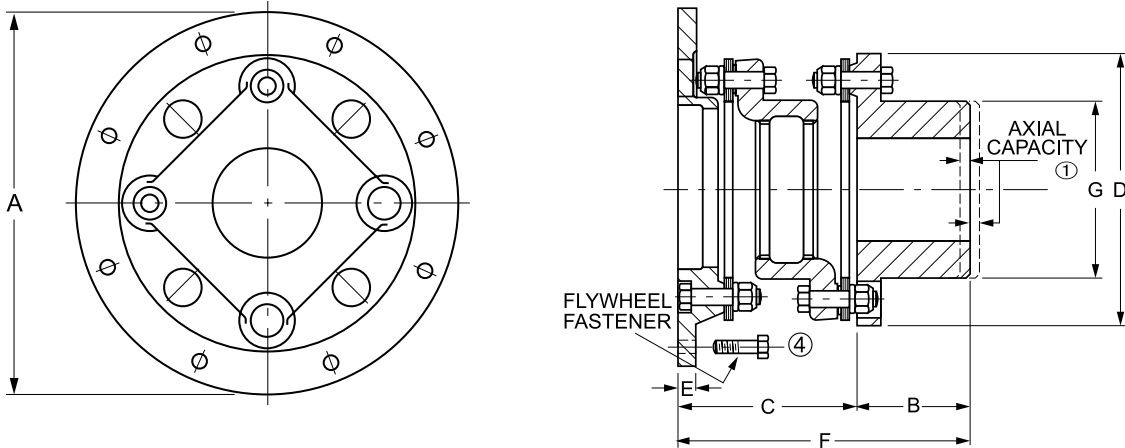
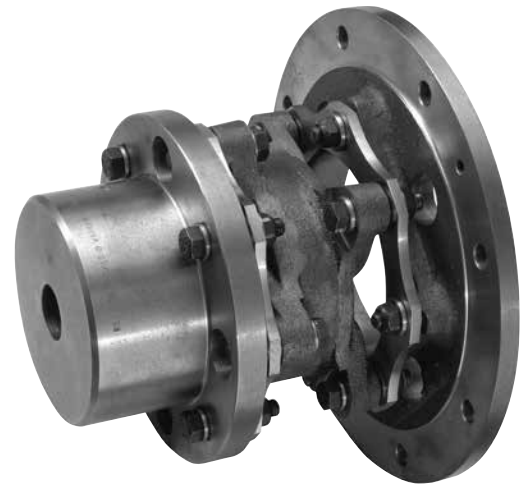

Flywheel Adapter Information

Adapters can be furnished to accommodate virtually any flange design. Where possible, the user should select dimensions from the tables below, as these represent industry standards and thus are the most economical selection. Note that most sizes are available either with SAE bolting or Thomas heavy-duty bolting.

Available Adapters

Coupling Size	Adapters Available in Shaded Sizes (in)										
	8.500	9.500	10.375	12.375	13.875	16.000	18.375	20.375	22.500	26.500	28.875
Adapter Tolerance	8.498	9.498	10.373	12.373	13.873	15.998	18.373	20.372	22.497	26.497	28.872
162											
200											
225											
262											
312											
350											
375											
425											
450											
500											
550											
600											
700											
750											
800											
850											

Available In These Sizes

Sizes 925 to 1550 - Adapting dimensions available upon request.

Bolting

Standard A Diameter (in)	Light-Duty SAE Bolting			Heavy-Duty Thomas Bolting		
	Bolt Circle	No. Holes	Size (Dia.)	Bolt Circle	No. Holes	Size (Dia.)
8.5	7.88	6	0.34	7.50	8	0.41
9.5	8.75	8	0.34	8.62	8	0.47
10.38	9.62	6	0.41	9.50	8	0.47
12.38	11.62	8	0.41	11.50	8	0.53
13.88	13.12	8	0.41	12.50	8	0.66
16	-	-	-	14.38	8	0.78
18.38	17.25	8	0.53	16.75	8	0.78
20.38	19.25	8	0.53	18.50	8	0.91
22.5	21.38	6	0.66	20.50	8	1.03
26.5	25.25	12	0.66	24.50	12	1.03
28.88	27.25	12	0.78	26.88	12	1.03

General Dimensions (in)

Coupling Size	⑦ Rough Bore	② Max. Bore	Min. "A" Dia.	B	C	D	E	F	G
162	—	1.88	6.25	1.75	3.32	4.56	0.31	5.07	2.75
200	—	2.25	7.38	2.12	3.87	5.75	0.38	5.99	3.62
225	—	2.63	7.62	2.50	3.87	6.00	0.38	6.37	3.88
262	—	3.13	8.50	2.88	4.47	6.88	0.44	7.35	4.50
312	—	3.63	9.50	3.38	5.34	8.12	0.50	8.72	5.44
350	—	4.00	10.88	3.75	5.89	9.12	0.50	9.64	6.00
375	—	4.50	11.88	4.00	6.62	10.06	0.56	10.62	6.50
425	—	4.75	13.12	4.25	7.18	11.00	0.62	11.43	7.00
450	—	5.13	14.75	4.50	7.68	11.88	0.69	12.18	7.44
500	2.69	5.38	16.00	5.00	8.75	13.44	0.75	13.75	8.38
550	2.69	6.00	18.00	5.50	9.89	15.00	0.88	15.39	9.44
600	3.69	6.50	18.38	6.00	10.89	16.75	1.00	16.89	10.31
700	4.25	7.50	20.38	7.00	12.48	18.94	1.00	19.48	11.75
750	4.94	8.00	24.00	7.25	13.54	20.62	1.12	20.79	12.62
800	5.19	8.75	25.62	7.75	14.74	22.38	1.25	22.49	13.75
850	5.44	9.25	27.38	8.25	15.86	23.75	1.25	24.11	14.50
925	5.94	10.12	28.88	9.00	17.24	25.75	1.38	26.24	15.88
1000	6.50	11.00	31.62	9.50	18.57	28.25	1.62	28.07	17.50
1100	7.00	12.00	33.38	10.25	19.81	30.25	1.75	30.06	18.50
1200	7.50	13.00	37.50	11.00	21.56	33.88	2.00	32.56	20.25
1300	8.00	14.00	39.88	12.00	23.31	36.00	2.12	35.31	22.12
1550	8.50	15.50	43.62	14.50	23.75	39.25	2.12	38.25	26.00

Coupling Size	Max. Horsepower per 100 RPM	③ Max. RPM	Max. Continuous Torque (lb-in)	⑧ Peak Overload Torque (lb-in)	⑤ ⑥ Weight (lb)	⑤ WR ² (lb-in ²)	① Axial Capacity
	Service Factor 1.0						
162	9.1	2,500	5,740	6,888	8	27	±0.036
200	17.5	2,500	11,030	13,236	12	68	±0.036
225	24.7	2,500	15,575	18,690	16	83	±0.036
262	33.4	2,500	21,038	25,245	25	178	±0.043
312	37.5	2,500	23,650	28,380	39	367	±0.051
350	83.8	2,300	52,800	63,360	56	630	±0.056
375	126	2,200	79,442	95,330	77	1,040	±0.062
425	140	2,200	88,000	105,600	101	1,780	±0.067
450	216	1,900	136,125	163,350	126	2,470	±0.072
500	319	1,800	200,750	240,900	178	4,310	±0.082
550	436	1,800	275,055	330,066	245	7,700	±0.092
600	569	1,800	358,875	430,650	321	11,500	±0.102
700	724	1,500	456,500	547,800	481	21,200	±0.115
750	1,023	1,500	644,930	773,916	610	34,300	±0.125
800	1,291	1,200	813,780	976,536	800	58,700	±0.136
850	1,426	1,100	898,700	1,078,440	975	73,300	±0.144
925	2,033	1,000	1,281,280	1,537,536	1,180	107,000	±0.156
1000	2,360	900	1,487,200	1,784,640	1,650	156,000	±0.172
1100	3,246	800	2,046,000	2,455,200	1,950	247,000	±0.183
1200	3,494	650	2,202,200	2,642,640	2,550	407,000	±0.203
1300	3,787	600	2,387,000	2,864,400	3,320	567,000	±0.218
1550	4,957	600	3,124,000	3,748,800	4,100	840,000	±0.242

- ① All Thomas disc couplings meet NEMA frame sleeve bearing motor specifications without modification or the addition of end-float restricting devices.
- ② Straight bores with no keyway require special material.
- ③ Maximum speeds are based on smallest available adapter O.D. For higher speeds, consult Rexnord.
- ④ Flywheel bolts are not supplied with coupling.
- ⑤ Weight and WR² at maximum bores and minimum adapter diameter.
- ⑥ Special hub available for size 600 with 6.75 in. max. bore. Consult Rexnord.
- ⑦ Consult Rexnord for minimum rough bore on sizes 162-450.
- ⑧ The peak overload torque is not an alternating torque limit.

The Series 44 is an all-steel fully machined flywheel adapter style coupling. It is used in heavy-duty applications where high starting torque, shock loads, torque reversals or alternating torques are present. This coupling is similar to the type CMR, but with the following benefits:

Dimension "C" and spool are adjustable to meet specific spacing requirements and/or to make adjustment to torsional characteristics.

The all-steel design provides a higher maximum continuous and peak overload torque rating. Fully-machined components offer a higher operating speed and balancing level.

Construction

- Hubs and Center Assembly: Carbon Steel
- Bolts: Alloy Steel
- Disc Packs: Tomaloy Tpack (225-750 Size)
- Coatings Available: Black Oxide, Zinc, Cadmium
- Other disc pack materials such as stainless steel, Monel and Inconel are available; please consult Rexnord.
- Misalignment: 1/3° per disc pack

When specified, Series 44 couplings meet all requirements of API 610 or API 671. If application requires API specification, please consult Rexnord.



Flywheel to Adapter Bolt Patterns

Standard A Diameter (in)	Light-Duty SAE Bolting			Heavy-Duty Thomas Bolting		
	Bolt Circle	No. Holes	Size (Dia.)	Bolt Circle	No. Holes	Size (Dia.)
12.375	11.62	8	0.41	11.50	8	0.53
13.875	13.12	8	0.41	12.50	8	0.66
16.000	N/A	N/A	N/A	14.37	8	0.78
18.375	17.25	8	0.53	16.75	8	0.78
20.375	19.25	8	0.53	18.50	8	0.91
22.500	21.38	6	0.66	20.50	8	1.03
26.500	25.25	12	0.66	24.50	12	1.03
28.875	27.25	12	0.78	26.88	12	1.03

All dimensions listed are in inches and bolt holes are equally spaced.

Flywheel Adapter Information*

Adapters can be furnished to accommodate most flange designs. Where possible, the user should select dimensions from the tables shown, as these represent industry standards that are more economical and readily available. Note that most sizes can be supplied with either SAE light-duty bolting or Thomas heavy-duty bolting. Please contact Rexnord for custom designs.

Coupling Size	Minimum Adapter "A" Dia.	① Standard Available Adapter Diameters (in) - Actual OD Tolerance as Listed							
		12.375	13.875	16.00	18.375	20.375	22.500	26.500	28.875
		12.373	13.873	15.998	18.373	20.372	22.497	26.497	28.872
350	10.88	Wt. = 3.88 WR ² = 132	Wt. = 8.25 WR ² = 320	Wt. = 15.3 WR ² = 716	Wt. = 24.4 WR ² = 1,391	Wt. = 33 WR ² = 2,200	Wt. = 43.1 WR ² = 3,365		
375	11.88	Wt. = 1.51 WR ² = 56	Wt. = 6.41 WR ² = 267	Wt. = 14.3 WR ² = 710	Wt. = 24.5 WR ² = 1,466	Wt. = 34.1 WR ² = 2,371	Wt. = 45.5 WR ² = 3,681		
425	13.12		Wt. = 2.79 WR ² = 127	Wt. = 11.5 WR ² = 616	Wt. = 22.8 WR ² = 1,453	Wt. = 33.5 WR ² = 2,460	Wt. = 46 WR ² = 3,901		
450	14.75			Wt. = 5.89 WR ² = 349	Wt. = 18.4 WR ² = 1,277	Wt. = 30.3 WR ² = 2,396	Wt. = 44.3 WR ² = 4,008	Wt. = 74.3 WR ² = 8,543	
500	16.00			Wt. = 0 WR ² = 0 ①	Wt. = 13.6 WR ² = 1,009	Wt. = 26.5 WR ² = 2,223	Wt. = 41.7 WR ² = 3,973	Wt. = 74.4 WR ² = 8,912	Wt. = 96.3 WR ² = 13,118
550	18.00				Wt. = 2.67 WR ² = 221	Wt. = 17.8 WR ² = 1,645	Wt. = 35.6 WR ² = 3,695	Wt. = 74 WR ² = 9,493	Wt. = 99.7 WR ² = 14,429
600	18.38				Wt. = 0 WR ² = 0 ①	Wt. = 17.2 WR ² = 1,618	Wt. = 37.5 WR ² = 3,956	Wt. = 81 WR ² = 10,529	Wt. = 110 WR ² = 16,107
700	20.38					Wt. = 0 WR ² = 0 ①	Wt. = 20.3 WR ² = 2,338	Wt. = 63.8 WR ² = 8,911	Wt. = 93 WR ² = 14,519
750	24.00							Wt. = 31.4 WR ² = 5,017	Wt. = 64.2 WR ² = 11,313
800	25.62							Wt. = 12.7 WR ² = 2,157	Wt. = 49.2 WR ² = 9,166
850	27.38								Wt. = 23.4 WR ² = 4,631
925	28.88								Wt. = 0 WR ² = 0 ①
1000	31.62	No industry standards exist for adapters to fit couplings this size or larger. Consult Rexnord.							

* Weight adder values are given in pounds. WR² values are given in lb-in².

① Wt. and WR² is zero if the listed minimum adapter "A" diameter is the same as complete coupling calculated values in general dimension tables on page 18.

NOTE: Add Wt. and WR² values listed in table to the weight and inertia values provided on page 18 for given size to calculate actual values based on selected adapter size.

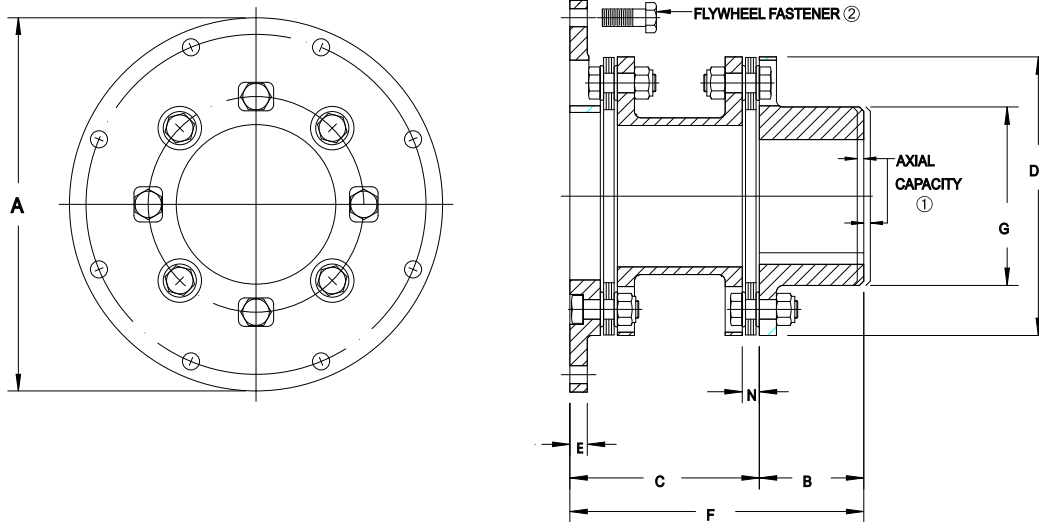

General Dimensions (in)

Coupling Size	Max. Bore	Min. "A" Dia.	B	Std. C	Min. C	D	E	F (Ref.)	G	N
350	4.00	10.88	3.75	5.88	5.15	8.69	0.50	9.63	5.88	0.54
375	4.50	11.88	4.00	6.62	5.71	9.69	0.56	10.62	6.50	0.59
425	4.75	13.12	4.25	7.18	6.15	10.50	0.62	11.43	7.00	0.62
450	5.13	14.75	4.50	7.62	6.71	11.31	0.69	12.12	7.44	0.71
500	5.38	16.00	5.00	8.75	7.53	12.88	0.75	13.75	8.38	0.78
550	6.00	18.00	5.50	9.88	8.53	14.44	0.88	15.38	9.44	0.91
600	6.50	18.38	6.00	10.88	9.36	16.00	1.00	16.88	10.25	0.98
700	7.50	20.38	7.00	12.44	10.68	18.25	1.00	19.44	11.75	1.20
750	8.00	24.00	7.50	13.50	11.58	19.81	1.12	21.00	12.62	1.27
800	8.75	25.62	8.25	14.75	12.68	21.50	1.25	23.00	13.62	1.34
850	9.25	27.38	8.75	15.75	13.59	23.00	1.25	24.50	14.50	1.40
925	10.12	28.88	9.50	17.25	14.56	25.00	1.38	26.75	15.75	1.50
1000	11.00	31.62	10.50	18.56	16.91	27.50	1.62	29.06	17.25	1.69

Coupling Size	Max. Horsepower Per 100 Service Factor 1.0	Max. RPM ^③		Max. Continuous Torque (lb-in)	Peak Overload Torque (lb-in) ^④	Weight (lb) ^⑤	Weight Change Per Inch of "C" (lb)	WR ² (lb-in ²) ^⑤	WR ² Change Per Inch of "C" (lb-in ²)	Axial Capacity (in) ^①
		Not Balanced	Balanced							
350	92.2	3,200	10,500	58,080	116,160	51	0.83	588	4.82	± 0.056
375	135	3,000	9,400	85,000	170,000	70	1.03	994	7.21	± 0.062
425	150	2,800	8,700	94,500	189,000	93	1.42	1,560	11.68	± 0.067
450	216	2,700	8,100	136,125	272,250	120	1.47	2,450	13.72	± 0.072
500	319	2,500	7,100	200,750	401,500	177	2.29	4,340	27.17	± 0.082
550	494	2,300	6,300	311,430	622,860	259	2.88	8,090	42.75	± 0.092
600	624	2,150	5,700	393,325	786,650	325	3.35	11,835	61.50	± 0.102
700	793	1,950	5,000	499,870	999,740	490	4.86	22,435	108	± 0.115
750	1037	1,850	4,600	653,725	1,307,450	642	5.37	36,510	146	± 0.125
800	1387	1,750	4,300	874,000	1,748,000	803	5.54	54,155	199	± 0.136
850	1782	1,600	3,900	1,123,375	2,246,750	975	6.67	74,430	284	± 0.144
925	2450	1,500	3,600	1,544,400	3,088,800	1,289	8.49	113,780	413	± 0.156
1000	2813	1,500	3,250	1,773,200	3,546,400	1,655	8.54	173,840	506	± 0.172

- ① Thomas disc couplings meet NEMA MG1-14.37, 1-20.81, & 1-21.81 specifications without the addition of end-float restricting devices.
- ② Flywheel fasteners are not supplied with this coupling. Contact equipment manufacturer for this hardware and tightening instructions.
- ③ Maximum speeds are based on use with all standard available adapters. For larger sizes or higher speeds, please consult Rexnord.
- ④ The peak overload torque rating is an infrequent torque overload limit and not an alternating or vibratory torque limit.
- ⑤ Weight and WR² values are based on maximum bores and minimum adapter diameters listed above.

Construction

Hubs and Center Member: Aluminum alloy, anodized
 Rivets: Brass
 Washers: Brass
 Discs: Stainless steel
 Set screws: 18-8 Stainless steel, Passivated
 Max. Temperature: 250°F
 Available with electronically insulated phenolic material.

Guide to Proper Designation of Hubs

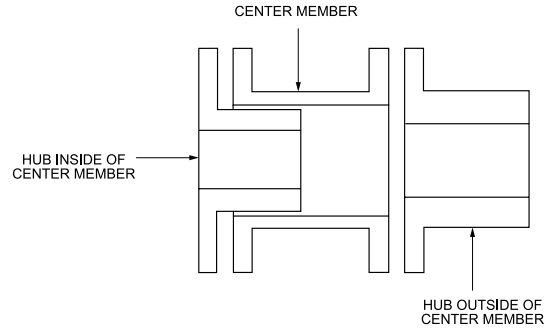

Style CC

This coupling has both hubs inverted and is designed to fit shafts normally encountered at a given torque range. Ideal for use where space limitations require close coupling of the shafts.

General Dimensions (in)

Coupling Size	A	B	C	F	T	① Torque Capacity (lb-in)
12	0.500	0.250	0.0313	0.531	0.018	1.1
18	0.750	0.375	0.0625	0.813	0.023	2.2
25	1.000	0.500	0.0625	1.063	0.025	4.7
37	1.437	0.688	0.125	1.500	0.035	19.0
50	1.750	0.938	0.125	2.000	0.045	75.0
62	2.250	1.063	0.125	2.250	0.060	300
75	2.500	1.188	0.125	2.500	0.060	440
100	3.000	1.375	0.250	3.000	0.060	700

- ① Torque capacities are based on smooth drives with moderate torque fluctuations. Reduce ratings to 1/3 the value shown for severe applications such as indexing drives where torque reversals occur.
- ② All Thomas disc couplings meet NEMA frame sleeve bearing motor specifications without modification or the addition of end-float restricting devices.

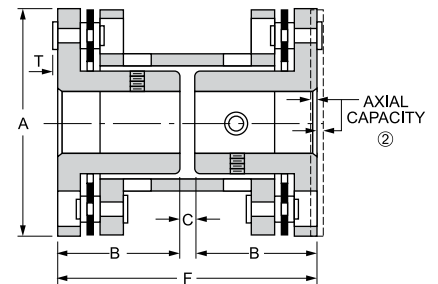
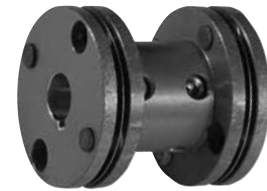

Style CA

This design of our miniature coupling has one inverted hub to accept a normal shaft and one extended hub to accommodate oversize shafts. It also accommodates a larger shaft gap than the Style CC.

General Dimensions (in)

Coupling Size	A	B	C	F	G	T	① Torque Capacity (lb-in)
12	0.500	0.250	0.234	0.734	0.313	0.018	1.10
18	0.750	0.375	0.375	1.125	0.469	0.023	2.20
25	1.000	0.500	0.469	1.469	0.625	0.025	4.70
37	1.438	0.688	0.688	2.063	0.875	0.035	19.0
50	1.750	0.938	0.906	2.781	1.063	0.045	75.0
62	2.250	1.063	1.000	3.125	1.375	0.060	300
75	2.500	1.188	1.125	3.500	1.625	0.060	440
100	3.000	1.375	1.375	4.125	1.875	0.060	700

- ① Torque capacities are based on smooth drives with moderate torque fluctuations. Reduce ratings to 1/3 the value shown for severe applications such as indexing drives where torque reversals occur.
- ② All Thomas disc couplings meet NEMA frame sleeve bearing motor specifications without modification or the addition of end-float restricting devices.

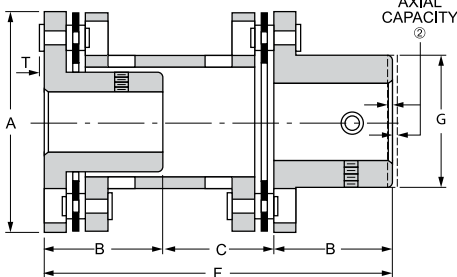

This coupling design has both hubs extended to accept two oversized shafts. Shaft gap is larger than that of the Style CA or CC couplings.

Style CBC is the newest addition to our miniature coupling line. It offers clamping hubs that are an integral part of the coupling. The clamping hubs assure positive fit on the shafts. There are no loose parts to handle during installation. The Style CBC coupling has the same dimensions and torque capacities as the Style CB. Consult Rexnord for additional design and engineering data.

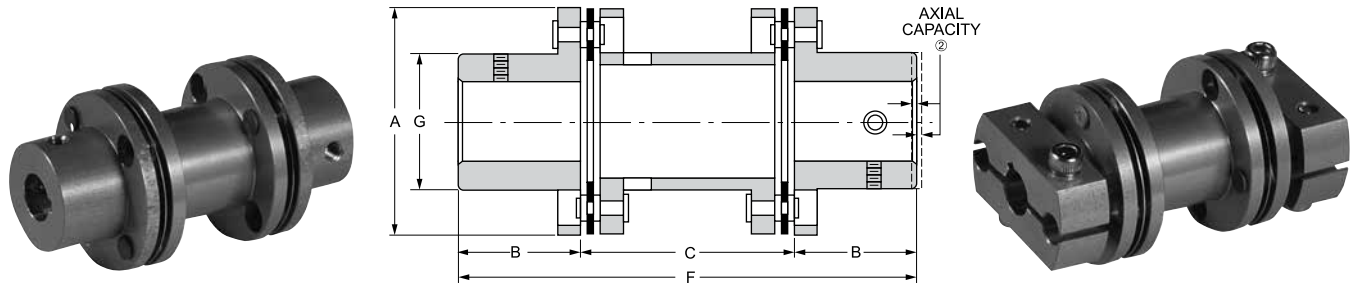

General Dimensions (in)

Coupling Size	A	B	C	F	G	Torque Capacity (lb-in)
12	0.500	0.250	0.438	0.938	0.313	1.10
18	0.750	0.375	0.688	1.438	0.469	2.20
25	1.000	0.500	0.875	1.875	0.625	4.70
37	1.437	0.688	1.250	2.625	0.875	19.0
50	1.750	0.938	1.688	3.563	1.063	75.0
62	2.250	1.063	1.875	4.000	1.375	300
75	2.500	1.188	2.125	5.000	1.625	440
100	3.000	1.375	2.500	5.000	1.875	700

Styles CC, CA, CB & CBC
Ratings and Mass Elastic Data

Coupling Size	Max. RPM	① Approx Weight (oz)	① Approx WR ² (oz-in ²)	Torsional Rigidity Kt (lb-in/radian)	Max. Angular Misalignment Continuous Per Flexing Element	Max. Parallel Misalignment Continuous (in)	Axial Capacity (lb-in)
12	150,000	0.09	0.00	422	2°	0.015	±0.016
18	100,000	0.29	0.02	688	2°	0.015	±0.016
25	80,000	0.74	0.08	1689	2°	0.028	±0.031
37	55,000	2.02	0.47	11,282	1.5°	0.028	±0.031
50	45,000	4.02	1.42	17,265	1°	0.028	±0.031
62	35,000	9.36	4.99	44,964	0.67°	0.028	±0.031
75	30,000	11.57	8.61	70,225	0.67°	0.028	±0.031
100	25,000	20.00	23.00	94,697	0.50°	0.020	±0.031

① Weight and WR² at maximum bore.

② All Thomas disc couplings meet NEMA frame sleeve bearing motor specifications without modification or the addition of end-float restricting devices.

The Style CE coupling consists of two Style CS single flexing couplings that are connected by a tubular shaft. It is designed to span large distances between shafts and is ideal for those applications where a large amount of parallel misalignment is anticipated.

The Style CS is designed for applications where one shaft is fully supported in its own bearings and the other shaft is single-bearing supported. The single flexing design can only accept angular misalignment.

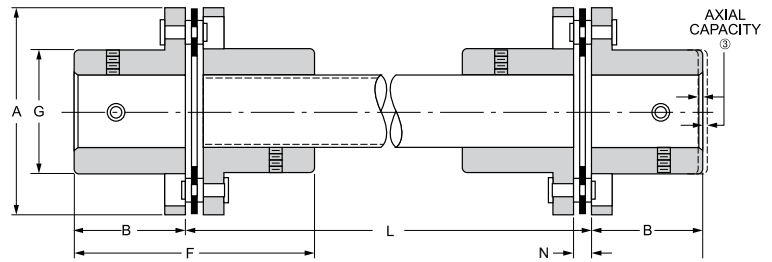

General Data ④

Coupling Size	A	B	N	F	G	L	Max. RPM		① Torque Capacity (lb-in)	Weight (oz)		Weight Change Per Inch of "L" (oz)
							Style CE	Style CS		② CE	CS	
12	0.500	0.250	0.031	0.531	0.313	Varies to suit as required	Consult Rexnord	150,000	1.1	0.45	0.06	0.027
18	0.750	0.375	0.063	0.813	0.469			100,000	2.2	0.97	0.20	0.048
25	1.000	0.500	0.094	1.094	0.625			80,000	4.7	1.70	0.50	0.059
37	1.438	0.688	0.109	1.484	0.875			55,000	19	4.10	1.40	0.110
50	1.750	0.938	0.141	2.016	1.063			45,000	75	7.80	2.82	0.180
62	2.250	1.063	0.172	2.297	1.375			35,000	300	14.30	5.85	0.220
75	2.500	1.188	0.188	2.563	1.625			30,000	440	18.10	6.02	0.380
100	3.000	1.375	0.225	2.975	1.875			25,000	700	28.60	12.8	0.420

- ① Torque capacities are based on smooth drives with moderate torque fluctuations. Reduce ratings to 1/3 the value shown for severe applications such as indexing drives where torque reversals occur.
- ② Weight calculated at maximum bore and "L" = 12".
- ③ All Thomas disc couplings meet NEMA frame sleeve bearing motor specifications without modification or the addition of end-float restricting devices.
- ④ For WR², misalignment capacities and torsional rigidity consult Rexnord.

Standard Bore Sizes for Style CC, CA, CB, CBC, CE & CS Miniature Couplings ①

Coupling Size	Bores ②③ (in)		Coupling Size	Bores ②③ (in)	
	Hub Inside Center Member	Hub Outside Center Member		Hub Inside Center Member	Hub Outside Center Member
12	0.0781, 0.0937	0.1200, 0.1250	50	0.2505, 0.3130	0.2505, 0.3130
	0.1200, 0.1250	0.1562, 0.1875		0.3755, 0.4380	0.3755, 0.4380
18	0.0937, 0.1200	0.1250, 0.1562	62	0.3755, 0.4380	0.4380, 0.5005
	0.1250, 0.1562	0.1875, 0.2500		0.5005, 0.6255	0.6255, 0.7505
25	0.1255, 0.1880	0.1255, 0.1880	75	0.4380, 0.5005	0.5005, 0.6255
	0.2505	0.2505, 0.3130		0.6255, 0.7505	0.7505, 0.8755
37	0.1255, 0.1880	0.1880, 0.2505	100	0.6255, 0.7505	0.7505, 0.8755
	0.2505, 0.3130	0.3130, 0.3755		0.8755, 1.0005	1.0005, 1.1255
	0.3755	0.4380, 0.5005			1.2505

- ① Couplings not available with rough bore. Keyway not included in standard bore. Keyways and nonstandard bores also available.
- ② Tolerances: Sizes 12 and 18, ±0.0003". Larger sizes, ±0.0005".
- ③ The largest bore shown for each hub is maximum allowable bore. Consult Rexnord if a larger bore is required.

Rexnord Thomas Supported Products

Series 63 couplings incorporate a patented* one-piece disc/diaphragm flexing element for positive torque transmission with low restoring forces. This unitized assembly accommodates misalignment and transmits torque through a multiple disc arrangement which provides redundancy in construction with a high degree of reliability. Pilot plates on the sides of each flexing element give accurate, repeatable registration of coupling components, and retain original dynamic balance repeatability while protecting the flexing members from damage.

Series 63 couplings are ideal for the most demanding drive requirements. Prime movers include motor, steam and gas turbines, rotary engines, and gas expanders. Driven equipment applications include centrifugal and rotary compressors, generators, test stands, boiler feed pumps and other multi-stage pumps, and marine propulsion drives. Custom designs available for torsional tuning and reduced moment.

*U.S. Patent 4055966

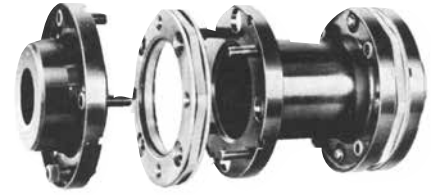

To determine Kt for a coupling with longer than standard "C" dimension, use the formula shown to the right:

$$K_t = \frac{1}{\frac{1}{K_t} + \frac{\Delta L}{\Delta K_t}}$$

Where ΔL = additional "C" dimension required ΔK_t = torsional stiffness change per inch of "C" dimension and $1/K_t$ - inverse of catalog value.

Construction

- Hubs and Center Member: Heat-treated alloy steel
- Bolts: Alloy steel
- Disc Packs: High strength 300 series stainless steel
- Coatings Available: Consult Rexnord
- Other disc pack materials such as stainless steel, Monel and Inconel are available; please consult Rexnord.
- When specified, Series 63 couplings meet all requirements of API 671.
- If application requires API specification, please consult Rexnord.

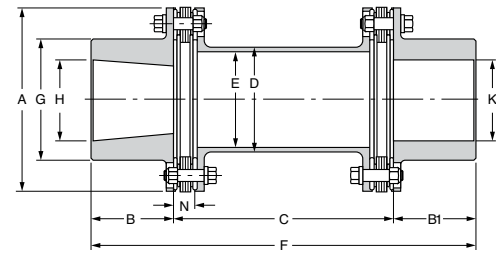

General Dimensions (in)

Coupling Size	Max. Bore		A	B	B1	① Std. C	Min. C	D	E	F	② G Max.	N	Capacity
	Hydraulic H	Keyed K											
162	2.00	1.88	4.25	2.06	1.88	5.00	3.25	2.41	2.22	8.94	2.81	0.53	±0.050
200	2.62	2.45	5.47	2.75	2.45	5.00	4.12	3.38	3.19	10.20	3.68	0.68	±0.070
225	2.81	2.62	5.72	2.91	2.62	5.00	4.25	3.50	3.31	10.53	3.94	0.70	±0.055
262	3.22	3.00	6.72	3.38	3.00	6.00	4.75	3.94	3.69	12.38	4.50	0.78	±0.060
312	3.75	3.50	8.00	3.94	3.50	6.00	5.00	4.75	4.44	13.44	5.25	0.94	±0.075
350	4.16	3.88	8.91	4.38	3.88	7.00	6.44	5.00	4.69	15.26	5.81	1.13	±0.080
375	4.69	4.38	9.88	4.88	4.38	7.00	6.62	6.06	5.72	16.26	6.56	1.17	±0.090
425	4.97	4.62	10.69	5.28	4.62	8.00	7.37	6.50	6.06	17.90	6.94	1.31	±0.100
450	5.36	5.00	11.50	5.69	5.00	8.00	7.62	7.00	6.55	18.69	7.50	1.37	±0.110
500	6.00	5.58	13.12	6.47	5.58	9.00	8.50	7.75	7.19	21.05	8.38	1.48	±0.120
550	6.70	6.25	14.75	7.38	6.25	9.88	9.88	8.75	8.06	23.51	9.38	1.73	±0.140
600	7.33	6.83	16.38	8.06	6.83	11.25	11.25	9.38	8.58	26.14	10.25	2.03	±0.150
700	8.17	7.62	18.69	8.97	7.62	12.00	-	10.63	9.67	28.59	11.44	2.10	±0.175
750	8.84	8.25	20.31	9.69	8.25	14.00	-	11.81	10.80	31.94	12.38	2.30	±0.190

Coupling Size	Dynamic Data			④ Standard Mass-Elastic Data						
	③ Max. Speed RPM	Max. Continuous Torque (lb-in)	Peak Overload Torque (lb-in)	Weight (lb)	WR ² (lb-in ²)	Kt (10 ⁶ lb-in/Rad)	C.G. (in)	Change per inch of "C"		
								Weight (lb)	WR ² (lb-in ²)	Kt (10 ⁶ lb-in/Rad)
162	36,000	5,890	14,700	7.76	16.5	0.502	0.37	0.19	0.26	10.5
200	28,600	13,600	34,000	16.4	59.8	1.78	0.56	0.27	0.76	29.9
225	26,700	21,100	52,700	19.2	78.2	2.33	0.62	0.28	0.82	33.6
262	22,500	37,800	94,500	30.7	167	3.9	0.67	0.42	1.53	62.7
312	19,100	64,100	160,000	51	397	5.66	0.74	0.63	3.33	137
350	17,200	81,900	205,000	69.2	666	9.54	0.79	0.67	3.9	160
375	15,600	126,000	315,000	93.1	1,100	12.3	0.99	0.89	7.72	317
425	14,300	169,000	423,000	118	1,630	19	0.97	1.21	11.9	491
450	13,300	213,000	533,000	147	2,330	21	1.09	1.35	15.5	636
500	11,600	316,000	790,000	214	4,350	34.8	1.2	1.85	25.8	1,060
550	10,300	454,000	1,135,000	308	7,870	49.9	1.35	2.54	45	1,850
600	9,300	630,000	1,575,000	416	13,000	61.3	1.37	3.15	63.5	2,610
700	8,200	903,000	2,258,000	605	24,600	100	1.46	4.25	110	4,510
750	7,500	1,150,000	2,875,000	773	37,000	131	1.52	5.02	162	6,600

- ① Standard dimension - may be modified as necessary.
- ② "G" dimension at listed maximum bore and will vary depending on bore size.
- ③ Consult Rexnord with higher speed requirements.
- ④ Weight and C.G. data based on standard "C" dimension, maximum hydraulic bores (H) and hydraulic hub lengths (B). Torsional stiffness (Kt) assumes a 1/3 shaft penetration factor.

SEE PAGES 11-13 FOR UPDATED VERSION WITH ENHANCED FEATURES

Series 52 couplings are all-purpose high-speed, high-torque couplings used where minimum coupling weight is desirable. They are commonly used on motor and turbine driven pumps, compressors and fans. Design modifications may be made to further reduce the coupling weight, making it an economic alternative to high performance disc and diaphragm couplings.

Construction

- Hubs and Center Assembly: Carbon Steel
- Bolts: Alloy Steel
- Disc Packs: Tomaloy Tpack (225-750 Size)
- Coatings Available: Black Oxide, Zinc, Cadmium
- Other materials such as stainless steel, Monel and Inconel are available; please consult Rexnord.
- Misalignment: 1/3° per disc pack

When specified, Series 52 couplings meet all requirements of API 610 or API 671. If application requires API specification, please consult Rexnord.



General Dimensions (in)

Coupling Size	⑥ Max. Bore	A	B	② Std. C	② Stocked C	Min. C	F	G	N
125	1.38	3.69	1.31	4.00	4	—	6.63	2.06	0.27
162	1.88	4.34	1.75	5.00	5	2.03	8.50	2.75	0.29
200	2.25	5.44	2.06	5.00	5	2.63	9.13	3.28	0.36
225	2.63	5.69	2.63	5.00	5 & 7	2.75	10.25	3.78	0.36
262	3.13	6.62	2.88	5.00	5 & 7	3.22	10.75	4.50	0.47
312	3.63	7.81	3.38	5.50	5.5 & 7	3.75	12.25	5.25	0.50
350	4.00	8.69	3.75	6.00	6 & 7	4.16	13.50	5.88	0.54
375	4.50	9.69	4.00	7.00	7	4.59	15.00	6.50	0.59
425	4.75	10.50	4.25	7.00	7	4.94	15.50	7.00	0.62
450	5.13	11.31	4.50	8.00	7 & 8	5.34	17.00	7.44	0.71
500	5.38	12.88	5.00	9.00	9	6.03	19.00	8.38	0.78
550	6.00	14.44	5.50	10.00	10	6.88	21.00	9.44	0.91
600	6.50	16.00	6.00	10.00	10	7.50	22.00	10.25	0.98
700	7.50	18.25	7.00	11.00	—	8.56	25.00	11.75	1.20
750	8.00	19.81	7.50	11.00	—	9.25	26.00	12.63	1.27
800	8.75	21.50	8.25	12.00	—	10.02	28.50	13.62	1.34
850	9.25	23.00	8.75	13.00	—	10.75	30.50	14.50	1.40
925	10.12	25.00	9.50	14.00	—	11.50	33.00	15.75	1.50
1000	11.00	27.50	10.50	14.50	—	—	35.50	17.25	1.69
1100	12.00	29.19	11.25	16.00	—	—	38.50	18.50	1.75
1200	13.00	32.12	12.25	17.00	—	—	41.50	20.25	1.97
1300	14.00	34.50	13.25	18.00	—	—	44.50	21.88	2.03

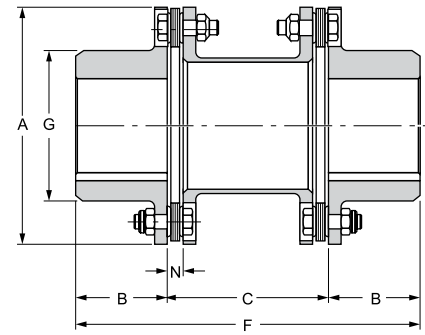

Taper Bores Also Available

Coupling Size	Max. Horsepower Per 100 RPM	⑤ Max. RPM		Max. Continuous Torque (lb-in)	Peak Overload Torque (lb-in)	④ Weight (lb)	Weight Change Per Inch of "C" (lb)	④ WR ² (lb-in ²)	WR ² Change Per Inch of "C" (lb-in ²)	① Axial Capacity (in)
	Service Factor 1.0	③ Not Balanced	Balanced							
125	4.28	5,000	15,000	2,700	5,400	4.6	0.16	7.4	0.15	±0.036
162	8.49	4,600	15,000	5,350	10,700	7.2	0.21	15.8	0.27	±0.036
200	16.7	4,250	15,000	10,500	21,000	12.4	0.25	43.7	0.58	±0.036
225	27.8	4,100	14,000	17,500	35,000	16.0	0.35	61	0.85	±0.036
262	52.1	3,900	13,000	32,830	65,660	26.0	0.50	137	1.6	±0.043
312	81.6	3,450	11,700	51,400	102,800	41.4	0.66	300	3.1	±0.051
350	106	3,200	10,500	66,900	133,800	58.6	0.83	528	4.8	±0.056
375	159	3,000	9,400	100,300	200,600	80.0	1.03	909	7.2	±0.062
425	213	2,800	8,700	134,300	268,600	104.0	1.43	1,380	11.7	±0.067
450	239	2,700	8,100	150,400	300,800	127	1.44	1,970	13.5	±0.072
500	391	2,500	7,100	246,400	492,800	196	2.30	3,800	27.2	±0.082
550	524	2,300	6,300	330,400	660,800	281	2.90	6,900	43.0	±0.092
600	688	2,150	5,700	433,800	867,600	370	3.30	11,200	61.2	±0.102
700	1,071	1,950	5,000	674,800	1,349,600	567	4.60	22,300	103.0	±0.115
750	1,331	1,850	4,600	838,800	1,677,600	712	5.20	33,100	143.0	±0.125
800	1,712	1,750	4,300	1,078,700	2,157,400	911	6.00	51,450	200.0	±0.136
850	2,020	1,600	3,900	1,273,000	2,546,000	1,109	6.00	71,700	200.0	±0.144
925	2,735	1,500	3,600	1,724,000	3,448,000	1,459	8.00	111,400	400.0	±0.156
1000	3,094	—	3,250	1,950,000	3,900,000	1,880	9.00	171,900	506.0	±0.172
1100	3,689	—	3,100	2,325,000	4,650,000	2,250	11.00	235,500	794.0	±0.183
1200	4,498	—	2,800	2,835,000	5,670,000	3,010	15.00	376,500	1,196.0	±0.203
1300	5,379	—	2,600	3,390,000	6,780,000	3,660	15.00	523,700	1,350.0	±0.218

- ① All Thomas disc couplings meet NEMA frame sleeve bearing motor specifications without modification or the addition of end-float restricting devices.
- ② Additional "C" dimensions available. Consult Rexnord.
- ③ Series 52 couplings meet AGMA Class 9 balance requirements as manufactured with interference fit bore and close fit keyway. If clearance fit and/or setscrews are required, please consult Rexnord. See page 4 for explanation of RPM limits and balancing recommendations.
- ④ Weight and WR² at maximum bore and standard "C" dimension listed.
- ⑤ Balance recommendations based on AGMA Specification 9000-C90 Average Sensitivity.
- ⑥ Consult Rexnord for minimum rough bore sizes.

SEE PAGES 21-23 FOR UPDATED VERSION WITH ENHANCED FEATURES

Series 71 couplings are designed for applications requiring a spacer-type coupling such as ANSI, API and other process pumps. Series 71 couplings are most commonly applied on motor, turbine, and gear driven pumps, compressors and blowers.

Series 71 is a simple three-piece design. Three piece design features unitized center member assembly and two piloted hubs. Hubs are piloted fit to the factory assembled center member. The piloting provides repeatable assembly of components for better dynamic balance characteristics. The center assembly simply “drops out” for fast installation or removal without special tools. The disc design allows for low flexing forces and high overload capacity.

Construction

- Hubs and Center Assembly: Carbon steel
- Bolts: Alloy steel
- Disc Packs: Stainless steel for 4- & 6-bolt designs
- Stainless steel Tpack for 8-bolt design
- Coatings Available: Black oxide, zinc, cadmium
- Other disc pack materials such as Monel and Inconel are available; please consult Rexnord.
- Misalignment: 1/2° per disc pack for 4- and 6-bolt designs, 1/3° per disc pack for 8-bolt design

When specified, Series 71 couplings meet all requirements of API 610 or API 671. If application requires API specification, please consult Rexnord.

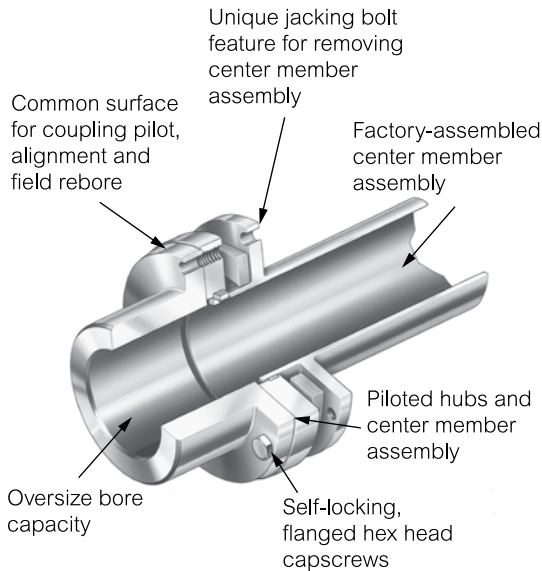

Series 71 Balance Recommendations

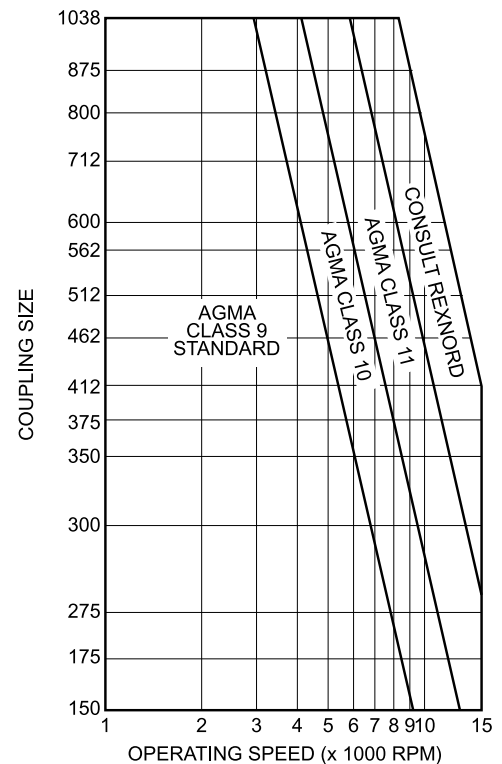

NOTE: These recommendations and balance classes are based on AGMA Specifications 9000-C90, high sensitivity. If conditions exist other than as defined in 9000-C90, for sensitivity, consult Rexnord. The above information should be used as a guide only. AGMA Class 9 balance is furnished as standard when Series 71 couplings are finished bored with interference fits.

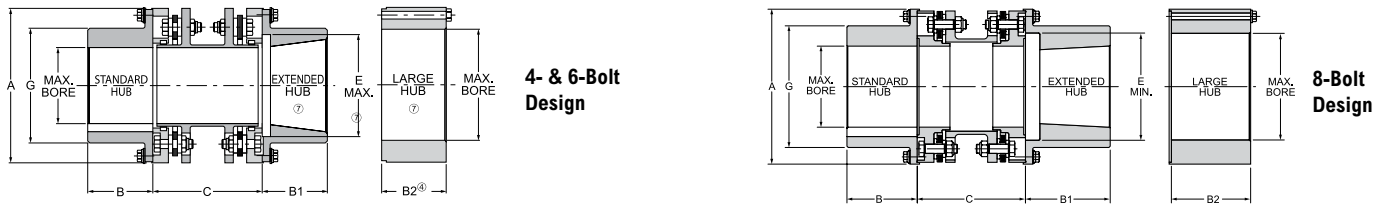

General Dimensions (in)

Coupling Size	⑥ B&B ¹ Hub Max. Bore	⑥ B ² Hub Max. Bore	A	③ B	B1	Std. B2	Std. C	Min. C	E	G
4-Bolt Design										
150	1.500	2.375	3.59	1.31	1.69	1.62	3.50	3.44	2.06	2.31
175	1.875	2.750	4.16	1.56	2.06	1.81	3.50	3.44	2.56	2.81
6-Bolt Design										
225	2.250	3.250	4.94	2.00	2.50	2.06	5.00	3.44	3.09	3.34
300	3.000	4.000	5.97	2.62	3.25	2.75	5.00	4.00	4.13	4.44
350	3.500	4.500	6.75	3.12	3.75	3.00	5.00	4.88	5.00	5.25
375	3.750	5.000	7.62	3.25	4.00	3.25	5.50	5.00	3.31	5.66
412	4.125	5.310	8.00	3.62	4.38	3.62	7.00	6.12	5.75	6.09
462	4.625	6.000	9.00	4.12	5.00	4.12	7.00	7.00	6.31	6.84
512	5.125	6.690	10.03	4.50	5.38	4.50	7.00	7.00	7.06	7.62
562	5.625	7.310	10.97	5.00	6.00	5.00	8.00	8.00	7.69	8.38
600	6.000	7.810	11.72	5.25	6.38	5.25	9.00	9.00	8.31	8.94
8-Bolt Design										
225-8	3.000	3.750	5.97	2.50	3.12	3.06	5.00	4.75	4.19	4.56
262-8	3.438	4.188	6.88	3.06	3.69	3.56	7.00	5.50	4.69	5.19
312-8	4.188	5.125	8.00	3.56	4.31	4.12	7.50	6.00	5.75	6.31
350-8	4.688	5.562	8.94	3.88	4.75	4.50	7.50	6.75	6.50	7.06
375-8	5.250	6.500	9.94	4.44	5.31	5.16	7.50	7.25	7.13	7.94
425-8	5.625	6.750	10.75	4.88	5.88	5.50	8.00	7.50	7.44	8.44
450-8	6.188	7.500	11.56	5.06	6.19	6.00	9.00	8.75	8.38	9.28
500-8	7.000	8.750	13.12	5.94	7.06	6.75	11.00	10.25	9.13	10.50
550-8	7.625	—	14.69	6.56	7.81	—	11.50	11.50	10.00	11.50
600-8	8.812	—	16.38	7.19	8.44	—	12.50	12.50	11.75	13.22
700-8	9.750	—	18.56	8.31	9.69	—	14.50	14.50	12.78	14.69
750-8	10.812	—	20.12	8.94	10.31	—	15.75	15.75	14.31	16.25

Coupling Size	Max. Horsepower Per 100 RPM	④ Max. RPM		Max. Continuous Torque (lb-in)	Peak Overload Torque (lb-in)	② Weight (lb)	Weight Change Per Inch of "C" (lb)	② WR ² (lb-in ²)	WR ² Change Per Inch of "C" (lb-in ²)	① Axial Capacity (in)
	Service Factor 1.0	⑤ Not Balanced	④ Balanced							
4-Bolt Design										
150	1.48	9,000	20,800	930	1,860	6.7	0.10	10.6	0.03	±0.050
175	2.59	8,300	17,000	1,630	3,260	9.4	0.14	20.6	0.09	±0.070
6-Bolt Design										
225	4.86	7,700	16,000	3,060	6,120	14.0	0.19	42.0	0.25	±0.075
300	11.5	6,800	14,000	7,260	14,520	26.0	0.26	121.0	0.66	±0.085
350	21.3	6,200	13,500	13,400	26,800	43.0	0.42	259.0	1.18	±0.090
375	30.6	5,650	12,000	19,300	38,600	55.0	0.43	423.0	1.62	±0.095
412	35.7	5,350	11,000	22,500	45,000	71.0	0.60	615.0	2.90	±0.110
462	64.1	5,000	10,000	40,400	80,800	101.0	0.80	1,110.0	4.65	±0.120
512	87.3	4,700	9,200	55,000	110,000	135.0	1.04	1,830.0	7.43	±0.130
562	133.00	4,350	8,300	84,100	168,200	186.0	1.28	3,020.0	10.38	±0.145
600	145.00	4,150	7,800	91,700	183,400	228.0	1.75	4,250.0	17.51	±0.160
8-Bolt Design										
225-8	27.77	7,500	14,000	17,500	35,000	27.8	0.38	128.0	1.07	±0.036
262-8	52.09	6,800	12,500	32,830	65,660	43.0	0.46	265.0	1.95	±0.043
312-8	81.55	6,200	11,500	51,400	102,800	67.0	0.55	580.0	3.34	±0.051
350-8	106.00	5,700	10,500	66,900	133,800	95.0	0.75	1,031.0	5.63	±0.056
375-8	159.00	5,200	9,800	100,300	200,600	134.0	1.05	1,784.0	9.23	±0.062
425-8	213.00	5,000	9,300	134,300	268,600	169.0	1.22	2,616.0	12.60	±0.067
450-8	239.00	4,700	8,700	150,400	300,800	220.0	1.59	4,020.0	18.00	±0.072
500-8	391.00	4,200	7,900	246,400	492,800	341.0	2.12	8,040.0	31.40	±0.082
550-8	524.00	3,900	7,300	330,400	660,800	475.0	2.65	13,930.0	49.80	±0.092
600-8	688.00	3,600	6,800	433,800	867,600	653.0	3.05	24,130.0	69.10	±0.102
700-8	1,071.00	3,300	6,200	674,800	1,349,600	961.0	4.13	44,900.0	118.00	±0.115
750-8	1,331.00	3,100	5,800	838,800	1,677,600	1,242.0	5.17	69,220.0	175.00	±0.125

- ① All Thomas disc couplings meet NEMA frame sleeve bearing motor specifications without modifications or the addition of end-float restricting devices.
- ② Weight and WR² with standard length hubs, maximum bore and standard "C".
- ③ Extended hub length is designed longer in order to include a counter-bore for the threaded extension on a tapered shaft.
- ④ See page 4 for explanation of RPM limits and balancing recommendations.
- ⑤ Series 71 Coupling assembly meets AGMA Class 9 Balance when finish bored with interference fits.
- ⑥ Consult Rexnord for minimum rough bore sizes.
- ⑦ If a block hub is supplied, extra capscrews will be provided for center member jacking feature.

Replaces troublesome gear couplings on pulp and paper applications. The Thomas one-piece, factory-torqued assembly is easy to install. This coupling is designed to bolt directly to existing rigid hubs using the gear coupling bolts. Axial shims are supplied for minor axial positioning adjustment.

Construction

Hubs and Center Assembly: Carbon steel
 Bolts: Alloy steel
 Disc Packs: Stainless Tpack
 Coatings Available: Consult Rexnord
 Other disc pack materials such as Tomaloy, stainless steel, Monel and Inconel are available; please consult Rexnord.
 Misalignment: 1/3° per disc pack



Available Adapters

Gear Coupling (Falk) Thomas Coupling	#1½ (1015)	#2 (1020)	#2½ (1025)	#3 (1030)	#3½ (1035)	#4 (1040)	#4½ (1045)	#5 (1050)	#5½ (1055)	#6 (1060)	#7 (1070)
226											
262											
312											
350											
375											
425											
450											
500T											
550T											
600T											
700T											
750T											
800T											
850T											

Available In These Sizes

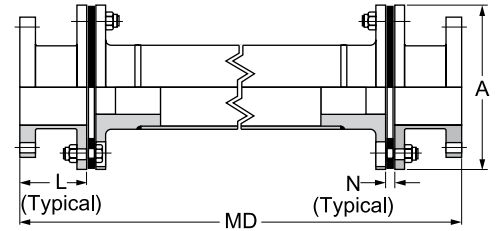

For other sizes, please consult Rexnord.

Coupling Size	Max. Horsepower per 100 RPM	Max. Continuous Torque (lb-in)	Peak Overload Torque (lb-in) ^②	A	L	Min. MD	N	Axial Capacity (in) ^①
	Service Factor 1.0							
226	22.6	14,260	28,520	5.81	4	16.25	0.58	0.036
262	34.9	22,000	44,000	6.69	4.5	17.25	0.47	0.043
312	44.7	28,200	56,400	7.81	5.12	20	0.5	0.051
350	55.7	35,100	70,200	8.75	5.31	22.12	0.54	0.056
375	123	77,300	154,600	9.69	6.62	26	0.59	0.062
425	187	117,850	235,700	10.5	6.5	26.25	0.62	0.067
450 ^③	216	136,000	272,000	11.31	6.75	28.5	0.78	0.072
500T	369	232,400	464,800	12.88	7.25	30	0.78	0.082
550T	427	269,200	538,400	14.44	7.75	33.5	0.91	0.092
600T	652	411,000	822,000	16	9.12	36.74	0.98	0.102
700T	871	549,000	1,098,000	18.25	9.25	40.5	1.2	0.115
750T	1,001	631,000	1,262,000	19.81	9.75	43	1.27	0.125
800T	1,441	908,000	1,816,000	21.5	10.25	—	1.34	0.136
850T	1,756	1,107,000	2,214,000	23	10.25	—	1.4	0.144

- ① All Thomas disc couplings meet NEMA frame sleeve bearing motor specifications without modification or the addition of end-float restricting devices.
- ② The peak overload torque is not an alternating torque limit.
- ③ Available with Tpack for new couplings, not retrofittable in size 450.

Floating shaft couplings are used to connect units which are relatively far apart. Such arrangements are particularly suited to transmit power into areas where moisture, dust or corrosive conditions would adversely affect the driving machinery. Floating shaft couplings' operating speeds are dependent upon the length of span required. Refer to the speed/span table for speed recommendations. In addition, special balancing may be required for high-speed service or for extended shaft lengths. Consult Rexnord for intended applications at speeds not covered in the table. The SN, SF and SV type couplings are furnished with stainless steel disc packs unless otherwise specified.

Type SN Full-Floating Shaft Coupling

Type SN couplings use a tubular center shaft, fabricated complete by Rexnord. Typical applications include cooling tower fan drives, paper machinery, printing presses, pumps and compressors.

Connected shafts should be rigidly supported and long shaft overhang should be avoided. The tubular coupling shaft **MUST NOT** be supported with a bearing. They may be operated vertically if length does not exceed 36 in.



Type SF Semi-Floating Shaft Coupling

Type SF couplings are a tubular shaft design with a stub shaft and bearing journal replacing the half-coupling on one end. They are typically used in tandem with the Type SN or Type SV where spans are too long for a single section of shafting.

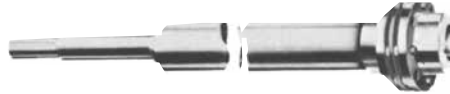

Type SV Vertical Floating Shaft Couplings

Type SV couplings are similar to the Type SN except that the lower half-coupling is modified to support the weight of the floating shaft. Typical applications include fresh-water pumps, sewage pumps, and marine cargo pumps. They may be used in tandem with the Type SF where spans are too long for a single shaft.



Corrosion Resistant Materials

Types SN, SV and SF couplings are particularly suited to applications involving wet or corrosive conditions, for this reason they are all furnished with 300 series stainless steel disc packs. For extremely corrosive environments, 316 stainless steel, Inconel 625 or Monel disc pack materials are available on request. As standard, these couplings are available in the following material classes.

NOTE: The stub shaft on the SF coupling is always furnished as unplated carbon steel in classes A, B, C and D. Couplings may be painted with acid and alkali resistant paints or coating besides the corrosion resistant classes listed.

CLASS

- A** – All steel
- B** – All steel – zinc plated
- C** – All steel – zinc plated w/stainless steel hardware
- D** – Stainless steel except for zinc plated hubs
- E** – All 300 series stainless steel

Floating Shaft Couplings

Types SN, SV and SF center members are of tubular construction, requiring special considerations for the operating speed and span length. The graph to the right may be used as a guide when determining whether it is desirable to balance the center member.

The standard procedure for balancing of SN, SV and SF couplings includes straightening of the tubular shaft prior to balancing. Many couplings of this type operate relatively near to the lateral resonant frequency of the coupling center member, and special balancing techniques are often required. For speeds 1800 RPM and under see page 4 for balancing recommendations. Consult Rexnord for any application with speed in excess of 1800 RPM.

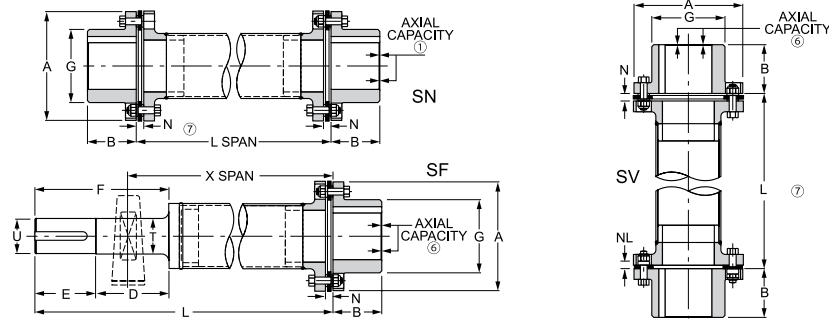

General Dimensions

Coupling Size	Coupling Type			Max. Bore	A	B	D	E	T	U	F	G	N	NL	Min. L	
	SN	SV	SF												SN	SF
50	•			0.63	2.00	0.88	—	—	—	—	—	1.00	0.24	—	4.00	—
62	•			0.75	2.44	1.09	—	—	—	—	—	1.19	0.32	—	4.50	—
75	•			0.88	2.69	1.13	—	—	—	—	—	1.44	0.33	—	4.75	—
100	•	•	•	1.16	3.22	1.38	3.75	1.75	0.94	0.88	5.50	1.69	0.45	0.13	5.75	12.00
125	•	•	•	1.38	3.84	1.63	4.25	2.13	1.19	1.13	6.38	2.06	0.52	0.15	6.25	12.20
162	•	•	•	1.88	4.47	1.88	4.50	2.63	1.44	1.38	7.13	2.75	0.54	0.16	6.75	13.20
200	•	•	•	2.25	5.44	2.13	5.50	2.88	1.69	1.63	8.38	3.28	0.57	0.16	7.50	15.50
226*	•	•	•	2.63	5.81	2.63	5.63	3.38	1.94	1.88	9.00	3.78	0.58	0.18	8.25	16.50
262	•	•	•	3.13	6.69	3.00	6.13	3.75	2.19	2.13	9.88	4.50	0.47	0.22	8.25	18.00
312	•	•	•	3.63	7.81	3.38	6.38	4.00	2.44	2.38	10.38	5.25	0.50	0.25	9.75	19.50
350	•	•	•	4.00	8.75	3.75	7.50	4.50	2.94	2.88	12.00	5.88	0.54	0.29	11.50	20.50
375	•	•	•	4.50	9.69	4.00	8.00	4.75	3.44	3.38	12.75	6.50	0.59	0.33	12.75	23.20
425	•	•	•	4.75	10.50	4.25	9.00	5.00	3.69	3.63	14.00	7.00	0.62	0.37	13.25	25.20
450*	•	•		5.13	11.31	4.50	—	—	—	—	—	7.44	0.78	0.40	15.00	—
500T	•	•		5.38	12.88	5.00	—	—	—	—	—	8.38	0.78	0.47	15.50	—
550T	•	•		6.00	14.44	5.50	—	—	—	—	—	9.44	0.91	0.53	18.00	—
600T	•	•		6.50	16.00	6.00	—	—	—	—	—	10.25	0.98	0.60	18.50	—
700T	•	•		7.50	18.25	7.00	—	—	—	—	—	11.75	1.20	0.70	22.00	—
750T	•	•		8.00	19.81	7.50	—	—	—	—	—	12.63	1.27	0.77	23.50	—
800T	•	•		8.75	21.50	8.25	—	—	—	—	—	13.62	1.34	0.84	26.00	—
850T	•	•		9.25	23.00	8.75	—	—	—	—	—	14.50	1.40	0.90	36.00	—
925T	•	•		10.12	25.00	9.50	—	—	—	—	—	15.75	1.50	1.00	36.00	—

Coupling Size	Max. Continuous Torque	Peak Overload Torque (lb-in)	Weight (lb)		Weight Change Per inch of "L"	WR ² (lb-in ²)		WR ² Change Per inch of "L"	Type SN Axial Capacity (in)
			SN, SV	SF		SN, SV	SF		
50	170	340	1.1	—	0.022	0.5	—	0.0026	±0.023
62	290	580	1.6	—	0.03	1.2	—	0.0063	±0.028
75	410	820	2.4	—	0.052	1.9	—	0.018	±0.032
100	820	1,640	4.9	3.6	0.076	5.3	3.1	0.033	±0.038
125	2,230	4,460	7.5	6.5	0.095	12.2	7.1	0.068	±0.046
162	4,250	8,500	11	10.5	0.13	27	15	0.22	±0.036
200	8,600	17,200	21	11	0.29	32	17	0.56	±0.036
226*	14,260	28,520	26.6	25	0.33	105	61	0.82	±0.036
262	22,000	44,000	38.6	36	0.41	218	133	1.6	±0.043
312	28,200	56,400	60.7	54	0.47	456	291	2.2	±0.051
350	35,100	70,200	85.5	78	0.52	807	478	3.1	±0.056
375	77,300	154,600	127	110	0.97	1,421	844	7.3	±0.062
425	117,850	235,700	173	—	1.58	2,448	—	15.9	±0.067
450*	136,000	272,000	206	—	1.58	3,350	—	15.9	±0.072
500T	232,400	464,800	239	—	2.38	4,955	—	41.1	±0.082
550T	269,200	538,400	337	—	2.38	8,400	—	41.1	±0.092
600T	411,000	822,000	442	—	3.37	14,510	—	91	±0.102
700T	549,000	1,098,000	717	—	4.56	27,970	—	120	±0.115
750T	631,000	1,262,000	882	—	4.56	40,270	—	120	±0.125
800T	908,000	1,816,000	1,140	—	5.45	64,170	—	205	±0.136
850T	1,107,000	2,214,000	1,420	—	6.00	91,730	—	274	±0.144
925T	1,466,000	2,932,000	1,820	—	6.89	143,500	—	414	±0.156

- ① All Thomas disc couplings meet NEMA frame sleeve bearing motor specifications without modification or the addition of end-float restricting devices.
- ② Shorter "L" requires special construction. Consult Rexnord.
- ③ Shaft tolerances: 5/16 to 11/2 + .000 - .0005, 1 5/8 to 311/16 .000 - .001. Key furnished with standard keyway in SF stub shaft.
- ④ Weight and WR² at max. bore and min. "L" dimension.
- ⑤ T suffix to coupling size indicates thin flange design. Consult Rexnord for larger sizes.
- ⑥ Types SF and SV end-float is one half ± value shown for type SN.
- ⑦ Maximum span (L) in inches for various speeds - For SN & SV
- ⑧ Consult Rexnord for larger sizes.

*Not available with Tpack.

Maximum Span at Given RPM

Coupling Size	3600 RPM	3000 RPM	1800 RPM	1500 RPM	1200 RPM	1000 RPM	900 RPM	750 RPM	720 RPM	600 RPM	500 RPM
50	Consult Rexnord		43	47	52	56	56	56	56	56	56
62	Consult Rexnord		50	54	61	67	70	75	75	75	75
75	Consult Rexnord		56	61	68	75	79	86	88	94	94
100	41	45	57	64	71	78	82	91	93	102	102
125	47	51	64	72	81	88	93	103	105	114	114
162	54	59	75	84	94	103	109	119	122	133	133
200	60	66	85	93	104	114	120	132	135	147	161
226	64	70	90	99	112	122	128	141	144	157	172
262	71	77	100	110	123	135	142	156	160	173	191
312	75	82	107	117	130	143	151	165	173	185	203
350	79	87	113	123	138	151	159	174	178	195	213
375	87	95	123	135	151	165	174	191	195	213	234
425	90	99	128	141	157	172	182	199	203	222	244
450*	90	99	128	141	157	172	182	199	203	222	244
500T	104	113	147	161	180	197	207	227	232	254	279
550T	Consult Rexnord		147	161	180	197	207	227	232	254	279
600T	Consult Rexnord		165	180	202	221	233	255	260	285	312
700T	Consult Rexnord		164	179	200	219	231	253	258	283	310
750T	Consult Rexnord		164	179	200	219	231	253	258	283	309
800T	Consult Rexnord		179	196	219	240	252	276	282	309	Consult Rexnord
850T	Consult Rexnord		187	205	229	251	265	290	296	309	Consult Rexnord
925T	Consult Rexnord		200	220	245	269	284	311	317	309	Consult Rexnord

* Not available with Tpack

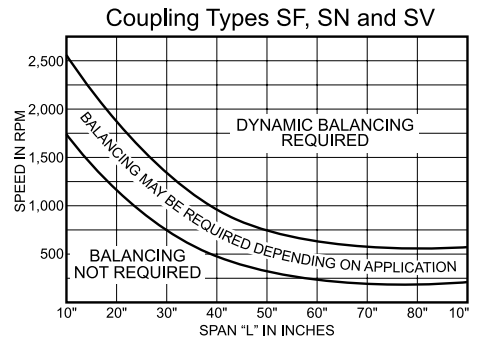

Type SN Adjustable

Type SN adjustable couplings were developed as emergency replacements for standard Type SN couplings and are available from stock in most sizes required for cooling tower applications. Each shaft may be adjusted through a four-inch length range, using a special compression bushing to lock the shaft in place once the length is set.

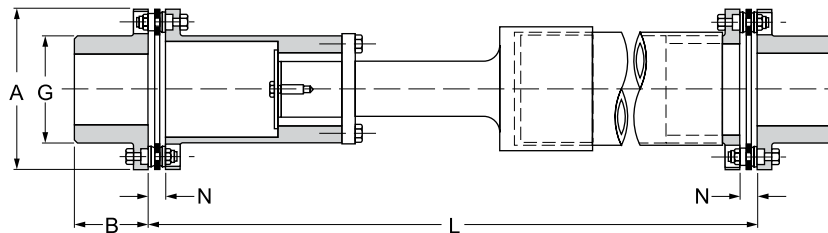

General Dimensions (in)

Coupling Size	Max. Bore	A	B	G	H	Min. "L"	Adjustment Range	② Weight (lb)	Weight Change Per inch of "L" (lb)	② WR ² (lb-in ²)	WR ² Change per inch of "L" (lb-in ²)	① Axial Capacity (in)
162	1.88	4.47	1.88	2.75	0.54	14.25	4.00	19	0.13	37	0.22	± 0.036
200	2.25	5.44	2.12	3.28	0.57	15.12	4.00	30	0.29	80	0.56	± 0.036
226	2.62	5.81	2.62	3.78	0.58	17.28	4.00	43	0.33	151	0.82	± 0.036
262	3.12	6.69	3.00	4.50	0.47	18.88	4.00	61	0.41	253	1.60	± 0.043

① All Thomas disc couplings meet NEMA frame sleeve bearing motor specifications without modification or the addition of end-float restricting devices.

② Weight and WR² at maximum bore.

Type SN single couplings are used for floating shaft applications where the user wishes to supply his own intermediate solid shaft, or for single-flexing applications where light-to-moderate radial loads occur. They are generally more economical than ST couplings.

Construction

- Hubs: Carbon steel
- Bolts: Alloy steel
- Disc Packs: Tomaloy Tpack (not available for size 450)
- Coatings Available: Consult Rexnord
- Other disc pack materials such as stainless steel, Monel and Inconel are available; please consult Rexnord.
- Misalignment: 1/3° per disc pack

NOTE:

Single-flexing couplings cannot accommodate parallel misalignment. They are not suitable for connecting equipment where both shafts are held rigidly in their own bearings.



General Dimensions (in)

Coupling Size	② Max. Bore	A	B	F	G	N
100	1.16	3.22	1.38	3.21	1.69	0.45
125	1.38	3.84	1.63	3.78	2.06	0.52
162	1.88	4.47	1.88	4.30	2.75	0.54
200	2.25	5.44	2.13	4.83	3.28	0.57
226	2.63	5.81	2.63	5.84	3.78	0.58
262	3.13	6.69	3.00	6.47	4.50	0.47
312	3.63	7.81	3.38	7.26	5.25	0.50
350	4.00	8.75	3.75	8.04	5.88	0.54
375	4.50	9.69	4.00	8.59	6.50	0.59
425	4.75	10.50	4.25	9.12	7.00	0.62
450	5.13	11.31	4.50	9.78	7.44	0.78
500T	5.38	12.88	5.00	10.78	8.38	0.78
550T	6.00	14.44	5.50	11.91	9.44	0.91
600T	6.50	16.00	6.00	12.98	10.25	0.98
700T	7.50	18.25	7.00	15.20	11.75	1.20
750T	8.00	19.81	7.50	16.27	12.63	1.27

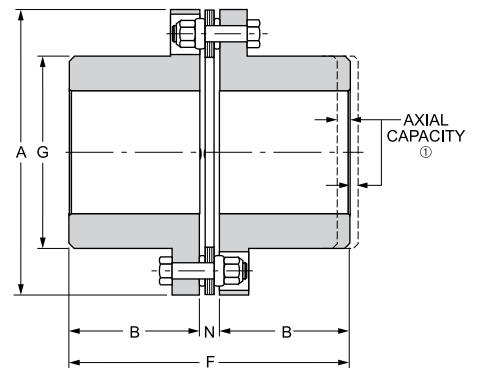

Coupling Size	Max. Horsepower Per 100 RPM	Max. RPM	Max. Continuous Torque (lb-in)	Peak Overload Torque (lb-in)	③ Weight (lb-in)	③ WR ² (lb-in ²)	① Axial Capacity (in)
	Service Factor 1.0						
100	1.3	7,100	820	1,640	2.3	2.7	±0.019
125	3.5	6,500	2,230	4,460	3.8	6.5	±0.023
162	7.1	6,000	4,450	8,900	5.8	17.1	±0.018
200	13.6	5,500	8,600	17,200	11	37	±0.018
226	22.6	5,200	14,260	28,520	14	53	±0.018
262	52.1	4,800	32,830	65,660	23	117	±0.022
312	81.6	4,500	51,400	102,800	37	264	±0.026
350	106	4,100	66,900	133,800	52	459	±0.028
375	159	3,900	100,300	200,600	71	770	±0.031
425	213	3,700	134,300	268,600	89	1,160	±0.034
450	239	3,600	150,400	300,800	121	1,580	±0.036
500T	391	2,800	246,400	492,800	150	2860	±0.041
550T	524	2,500	330,400	660,800	210	5,130	±0.046
600T	688	2,300	433,800	867,600	257	7,010	±0.051
700T	1,071	2,000	674,800	1,349,600	390	12,100	±0.057
750T	1,331	1,800	838,800	1,677,600	534	24,650	±0.062

- ① All Thomas disc couplings meet NEMA frame sleeve bearing motor specifications without modification or the addition of the end-float restricting devices.
- ② Consult Rexnord for minimum rough bore on sizes 162-450.
- ③ Weight and WR² shown at maximum bore.

Recommended Hub Bores for Clearance & Interference Fit on Keyed Shafting

Shaft Dia.	Clearance Fit		Interference Fit		Shaft Dia.	Clearance Fit		Interference Fit		Shaft Dia.	Interference Fit	
	Hub Bore	Clearance	Hub Bore	Interference		Hub Bore	Clearance	Hub Bore	Interference		Hub bore	Interference
+0.000	+0.010	.0000	+0.0005	.0000	3.1250	3.1250		3.1220		+0.000	0.0015	0.0015
-0.005	-0.000	.0015	-0.0000	.0010	3.1875	3.1875		3.1845		-0.0010	-.0000	0.0040
.5000	.5000		0.4990		3.2500	3.2500		3.2470		6.7500	6.7460	
.5625	.5625		0.5615		3.3125	3.3125		3.3095		7.0000	6.9960	
.625	.625		0.6240		3.3750	3.3750		3.3720				
.6875	.6875		0.6865		3.4375	3.4375		3.4350				
.7500	.7500		0.7490		3.5000	3.5000		3.4970				
.8125	.8125		0.8115		3.5625	3.5625		3.5595				
.8750	.8750		0.8740		3.6250	3.6250		3.6220				
.9375	.9375		0.9365		3.6875	3.6875		3.6845				
1.0000	1.0000		0.9990		3.7500	3.7500		3.7470				
1.0625	1.0625		1.0615		3.8750	3.8750		3.8720				
1.125	1.125		1.1240		3.9375	3.9375		3.9345				
1.1875	1.1875		1.1865		4.0000	4.0000		3.9970				
1.2500	1.2500		1.2490									
1.3125	1.3125		1.3115		+0.000	+0.015	.0000	+0.015	.0010			
1.3750	1.3750		1.3740		-0.010	-0.000	.0025	-0.000	.0035			
1.4375	1.4375		1.4365		4.0625	4.0625		4.0590				
1.5000	1.5000		1.4990		4.1250	4.1250		4.1215				
					4.1875	4.1875		4.1840				
+0.000	+0.010	.0000	+0.010	.0000	4.2500	4.2500		4.2465				
-0.010	-0.000	.0020	-0.000	.0020	4.3125	4.3125		4.3090				
1.5625	1.5625		1.5605		4.3750	4.3750		4.3715				
1.6250	1.6250		1.6230		4.5000	4.5000		4.4965				
1.6875	1.6875		1.6855		4.5625	4.5625		4.5590				
1.7500	1.7500		1.7480		4.6250	4.6250		4.6215				
1.8125	1.8125		1.8105		4.6875	4.6875		4.6840				
1.8750	1.8750		1.8730		4.7500	4.7500		4.7465				
1.9375	1.9375		1.9355		4.8125	4.8125		4.8090				
2.0000	2.0000		1.9980		4.8750	4.8750		4.8715				
					4.9375	4.9375		4.9340				
+0.000	+0.015	.0000	+0.010	.0000	5.0000	5.0000		4.9965				
-0.010	-0.000	.0025	-0.000	.0020	5.0625	5.0625		5.0585	0.0015			
2.0625	2.0625		2.0605		5.1250	5.1250		5.1210	0.0040			
2.1250	2.1250		2.1230		5.1875	5.1875		5.1835				
2.1875	2.1875		2.1855		5.2500	5.2500		5.2460				
2.2500	2.2500		2.2480		5.3125	5.3125		5.3085				
2.31250	2.31250		2.3105		5.3750	5.3750		5.3710				
2.3750	2.3750		2.3730		5.4375	5.4375		5.4335				
2.4375	2.4375		2.4355		5.5000	5.5000		5.4960				
2.5000	2.5000		2.4980		5.5625	5.5625		5.5585				
2.5625	2.5625		2.5605		5.6250	5.6250		5.6210				
2.6250	2.6250		2.6230		5.6875	5.6875		5.6835				
2.6875	2.6875		2.6855		5.7500	5.7500		5.7460				
2.7500	2.7500		2.7480		5.8125	5.8125		5.8085				
2.8125	2.8125		2.8105		5.8750	5.8750		5.8710				
2.8750	2.8750		2.8730		5.9375	5.9375		5.9335				
2.9375	2.9375		2.9355		6.0000	6.0000		5.9960				
3.0000	3.0000		2.9980		6.2500	6.2500		6.2460				
+0.000	+0.015	.0000	+0.015	.0000	6.5000	6.5000		6.4960				
-0.010	-0.000	.0025	-0.000	.0030								
3.0625	3.0625		3.0595									

NOTE: Consult Rexnord for all keyless bore fits.

Taper-Lock and Q.D. Bushing Selection Cross Reference

In order to cross reference tapered bushing and bore sizes to a coupling selection, the following tables will cover the majority of cases.

Taper-Lock Type

Bushing Size	Coupling Size and Type					
	Max. Bore	DBZ	SV, SF, SN	Series 52	Series 54RDG	AMR, BMR, CMR, ST
1108	1.125	126	125	125	162	162
1215	1.250	163	162	162	200	200
1310	1.375	201	200	200	200	200
1610	1.625	201	200	200	200	200
1615	1.625	201	200	200	225	200
2012	2.000	226	226	225	262	262
2517	2.500	263	262	262	312	312
2525	2.500	263	262	262	312	262
3020	3.000	351	350	350	375	375
3030	3.000	351	312	312	350	350
3535	3.500	401	375	375	450	425

NOTE: "C" Dimension will be as listed for all couplings; "F" Dimension will vary according to bushing selection; Consult Rexnord for "F" dimensions and bushings.

Hubs bored for Q.D. or Taper-Lock® bushings will be modified for proper fit with bushing length. Consult Rexnord for specific dimensional data.

If specific reference to the coupling series or type is not found in the table, i.e. special designs, comparison of the shaft size with the maximum bore table only, will indicate the correct taper bushing in the left side of each table. Other flange style and compression bushings can be used with coupling hubs.

Q.D. Type

① Bushing Size	Coupling Size and Type						
	Max. Bore	DBZ	SV, SF, SN	Series 52	Series 54RDG	Series 71	AMR, BMR, CMR, ST
JA	1.250	126	125	125	162	150	162
SH	1.625	163	162	200	200	175	200
SDS	1.938	201	226	225	225	300	200
SD	1.938	201	226	225	225	300	200
SK	2.500	263	262	262	312	300	262
SF	2.938	301	312	350	350	350	312
E	3.438	401	375	375	425	462	375
F	3.938	-	450	450	500	512	450

① With shallow keyway. Key supplied with bushing where shallow keyway is furnished.

Standard Keyway Dimensions – Tolerances

Nominal Shaft Diameter		Keyway			Keyway Tolerance		
Over	Thru	Width	Depth		Width		Depth
			Sq. ②	Rect. ②	Close Side Fit ③	Free Side Fit ④	
5/16	7/16	3/32	3/64	–			+0.015 -0.000
7/16	9/16	1/8	1/16	3/64			
9/16	7/8	3/16	3/32	1/16	+0.0005	+0.002	
7/8	1 1/4	1/4	1/8	3/32	-0.0015	-0.000	
1 1/4	1 3/8	5/16	5/32	1/8			
1 3/8	1 3/4	3/8	3/16	1/8	+0.0005	+0.0025	+0.023 -0.000
1 3/4	2 1/4	1/2	1/4	3/16	-0.0020	-0.000	
2 1/4	2 3/4	5/8	5/16	7/32			
2 3/4	3 1/4	3/4	3/8	1/4	+0.0005	+0.003	
3 1/4	3 3/4	7/8	7/16	5/16	-0.0025	-0.000	
3 3/4	4 1/2	1	1/2	3/8			
4 1/2	5 1/2	1 1/4	5/8	7/16	+0.0010	+0.0035	+0.030 -0.000
5 1/2	6 1/2	1 1/2	3/4	1/2	-0.0025	-0.000	
6 1/2	7 1/2	1 3/4	7/8	3/4	+0.0010	+0.004	
7 1/2	9	2	1	3/4	-0.0030	-0.000	

② Rectangular keyways recommended for shafts over 6 1/2" diameter.

③ Close Side Fit Keyways – recommended for reversing torque, drives or other drives which are vibratory in nature, or where zero backlash is required. A close side fit keyway will be furnished on all **Disc Type couplings** unless specified by the customer.

④ Free Side Fit Keyways – recommended for use on smooth, unidirectional drives where fitting of key as assembly cannot be tolerated. A free side fit keyway will be furnished on **DBZ couplings** with Class 1 clearance fits unless specified by customer.

The following pages illustrate a sampling of the special disc coupling products designed and manufactured by Rexnord for applications requiring special coupling designs; please contact your Rexnord representative.

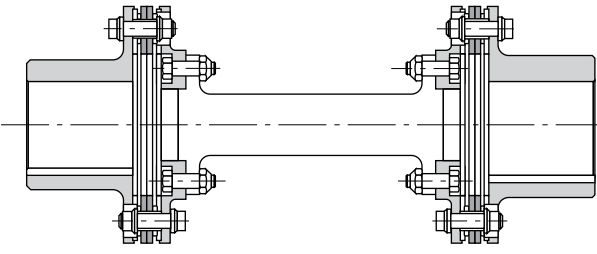
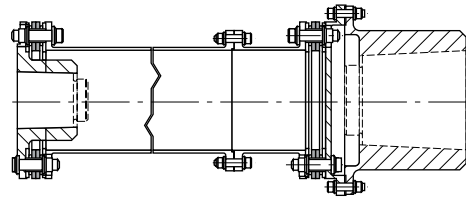
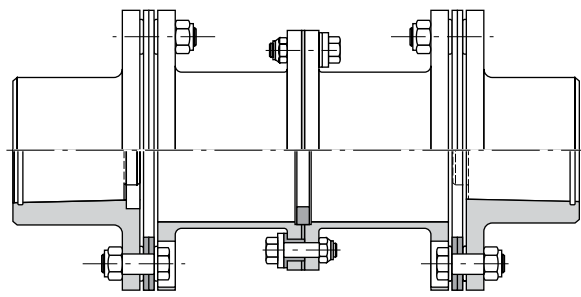
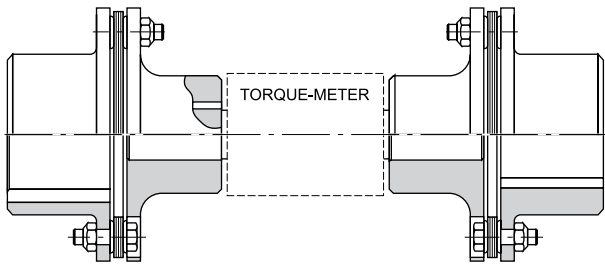
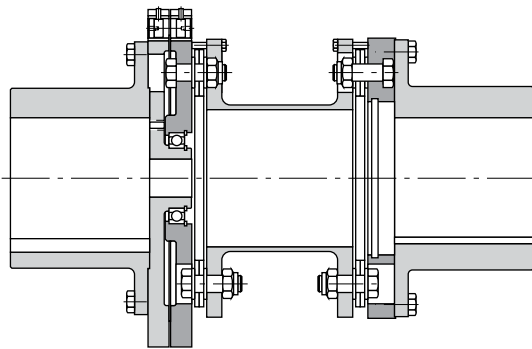
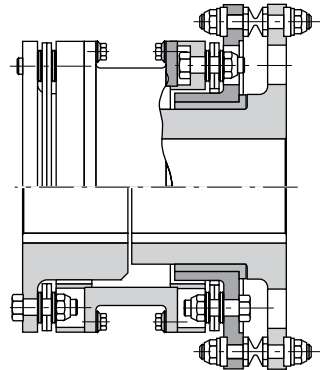
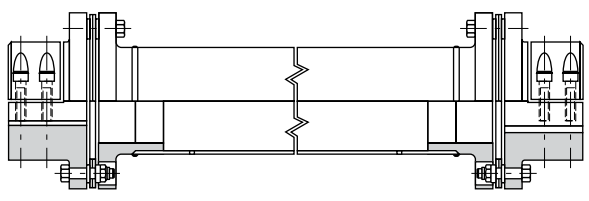
 <p>Torsionally Tuned Center Members</p>	 <p>Semi-Reduced Moment – Bolt On Hub</p>
 <p>Electrically Insulated Couplings</p>	 <p>Torque Meter Coupling</p>
 <p>Breaker Pin Coupling – Bearing Style</p>	 <p>Breaker Pin Coupling – Bushing Style</p>
 <p>Clamp Hub Mounting</p>	

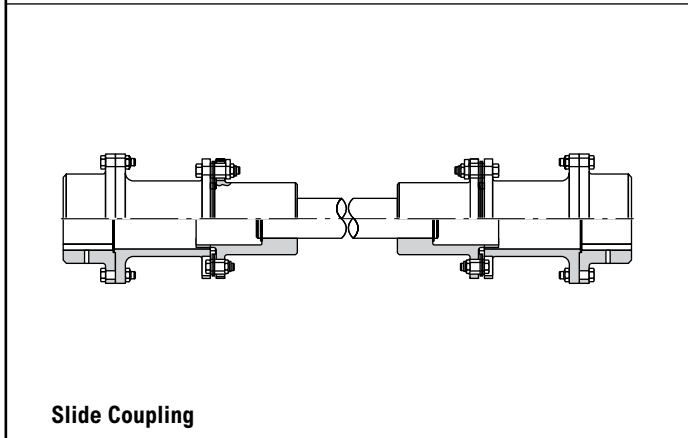
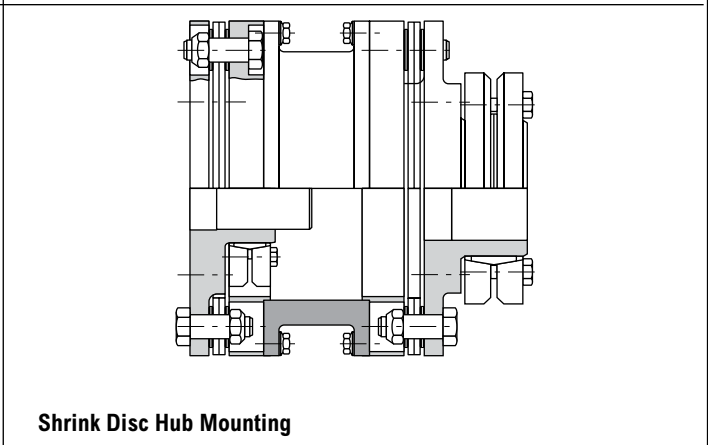
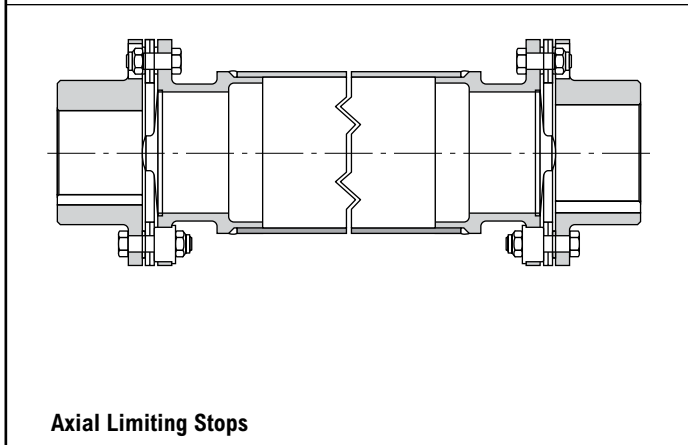
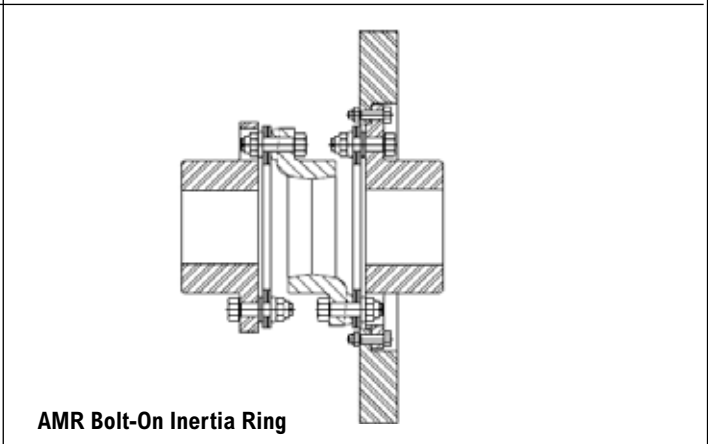
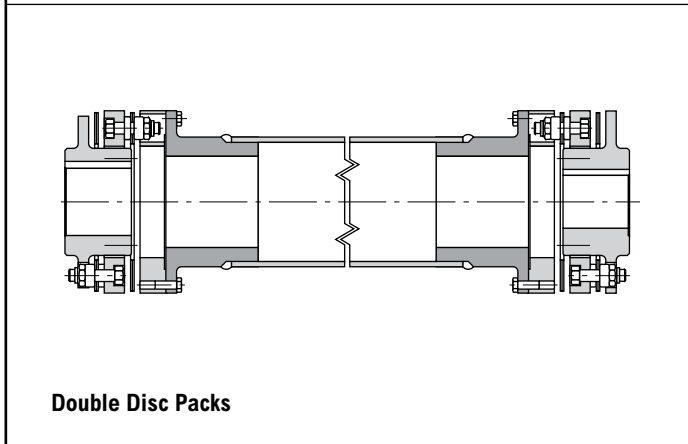
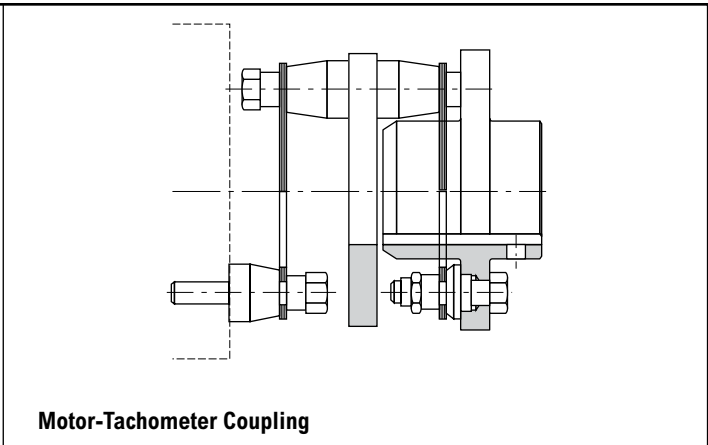
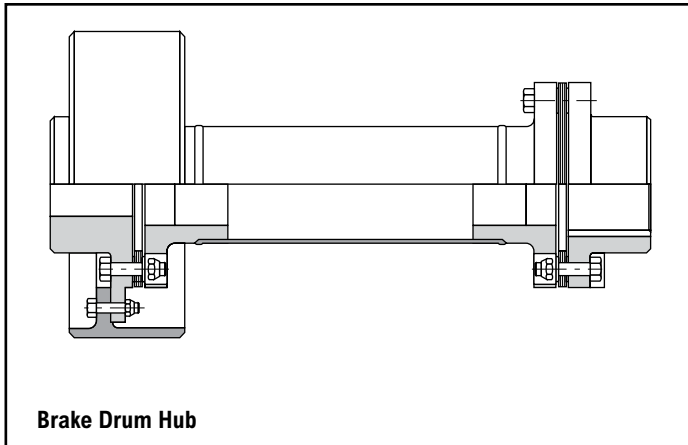



866-REXNORD/866-739-6673 (Within the U.S.)
414-643-2366 (Outside the U.S.)
www.rexnord.com

Why Choose Rexnord?

When it comes to providing highly engineered products that improve productivity and efficiency for industrial applications worldwide, Rexnord is the most reliable in the industry. Commitment to customer satisfaction and superior value extend across every business function.

Delivering Lowest Total Cost of Ownership

The highest quality products are designed to help prevent equipment downtime and increase productivity and dependable operation.

Valuable Expertise

An extensive product offering is accompanied by global sales specialists, customer service and maintenance support teams, available anytime.

Solutions to Enhance Ease of Doing Business

Commitment to operational excellence ensures the right products at the right place at the right time.

REXNORD

Rexnord Company Overview

Rexnord is a growth-oriented, multi-platform industrial company with leading market shares and highly trusted brands that serve a diverse array of global end markets.

Process & Motion Control

The Rexnord Process & Motion Control platform designs, manufactures, markets and services specified, highly engineered mechanical components used within complex systems where our customers' reliability requirements and the cost of failure or downtime are extremely high.

Water Management

The Rexnord Water Management platform designs, procures, manufactures and markets products that provide and enhance water quality, safety, flow control and conservation.