

THK

The Mark of Linear Motion

Linear Actuator Type: GL

High Performance / Low Cost



Linear Actuator with Ball Screw Drive

GL15S & GL20S Series

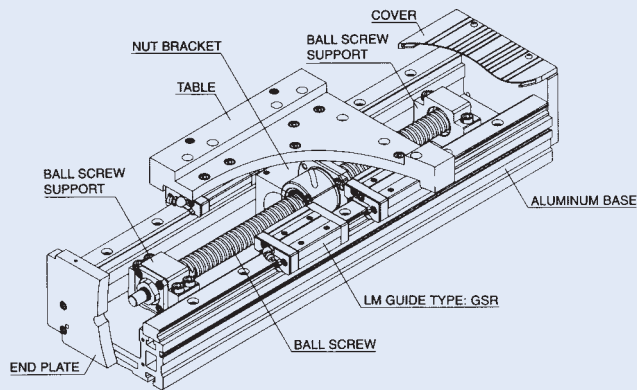

Figure 1

■ Rigid Construction

Incorporating the THK LM Guide Type GSR with a robust aluminum extrusion base and an oversized ball screw makes the GL15S and GL20S rigidly constructed, compactly designed linear actuators with high load capacities.

■ High Speed

By utilizing a THK Super Lead Ball Screw, some models can obtain a maximum linear velocity of 2000 mm (78") per second!

■ Standard Stroke Models

The GL15S and GL20S models are available up to 2000 mm* standard travel lengths for quick delivery. (*1500 mm max. for GL15S model)

■ Unsurpassed Economy

The GL Series Linear Actuators are attractively priced. Now you too can benefit from a high performance pre-engineered linear actuator solution that is sure to meet your budget requirement.

Linear Actuator with Belt Drive

GL15B & GL20B Series

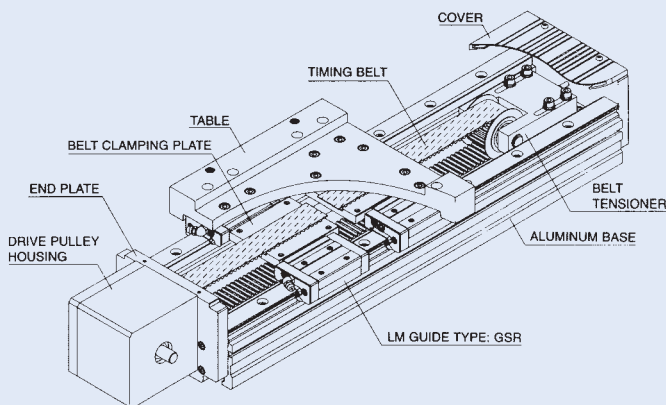

Figure 2

■ High Load Capacity / Compact Design

Combining the THK LM Guide Type GSR with a robust aluminum extrusion base and a steel reinforced timing belt drive, the GL15B and GL20B models provide a high load capacity linear slide in a compact package.

■ High Speed

By incorporating a belt drive design, the maximum linear velocity of the GL15B and GL20B models can exceed 3000 mm (118") per second!

■ Standard Stroke Up to 10 ft.

The GL15B and GL20B models are in stock up to 3000 mm* standard travel lengths for quick delivery. (*2000 mm max. for GL15B model)

■ Wide Range of Drive Options

The GL15B and GL20B belt drive models are available with a large selection of reducer options to fit a variety of drive motors for application specific conditions.

Mechanical Data

Accuracy Standards

Table 1

Unit: mm (inch)

Model Number	Type of Drive	Repeatability
GL15S GL20S	Ball Screw Drive	±0.02 (±0.00079")
GL15B GL20B	Timing Belt Drive	±0.08 (±0.00315")

LM Guide Basic Load Ratings

Table 2

Unit: kN

GL size	GL15		GL20	
LM Guide Model Number	GSR15T		GSR20T	
Loading Rating	C*	C ₀ **	C*	C ₀ **
A	5.69	8.43	9.22	13.20
B	5.29	7.56	8.57	11.90
C	4.78	6.58	7.74	10.30
D	5.29	7.56	8.57	11.90

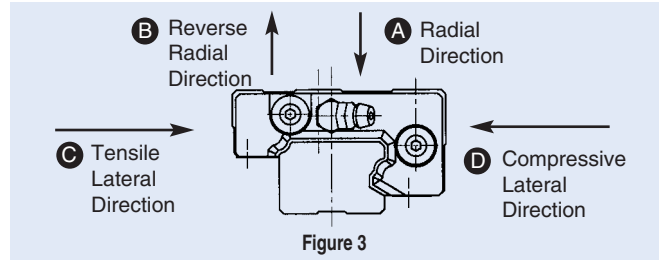

Figure 3

* C: Basic Dynamic Load Rating
Basic Dynamic Load Rating (C) is based on 50 km of travel life. This rating is used to determine the application dependent service life of the LM Guides incorporated in the GL.

**C₀: Basic Static Load Rating
Basic Static Load Rating (C₀) indicates the maximum load where the sum of the permanent deformations of the rolling element and raceway equals 0.0001 times the diameter of the rolling element.

Recommended Maximum Loads and Moment Loads*

Table 3

Unit: kg (lbs)

Mounting Orientation	GL15S	GL20S	GL15B	GL20B
Horizontal Use	113 (250)	181 (400)	34 (75)**	45 (100)**
Vertical Use	45.4 (100)	56.7 (125)	n/a	n/a

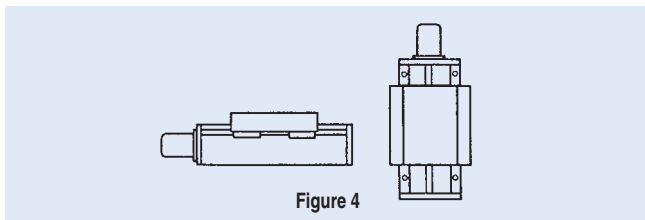

Figure 4

Table 4

Unit: N-m

Moment Direction	GL15	GL20
M _A	121.6	217.6
M _B	114.7	195.8
M _C	171.6	311.8

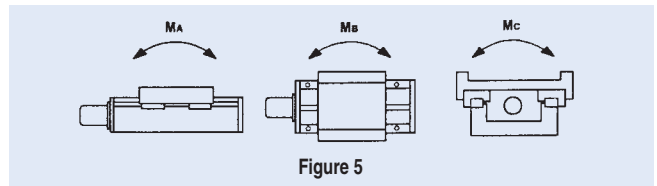

Figure 5

* Note: Consult a THK Engineer for precise application evaluation. Load ratings represent the maximum recommended operating loads & moments for optimal performance, allowing for safety, approximately 5000km of LM guide life, T-slot strength, implications of load inertia, and thrust load support. Capacity of the system in a static state will increase markedly. Note that the actual performance capability of a linear positioning system lies with the suitability of the actuator's motion control system with the parameters of the original application.

** Due to higher reflected load inertias and torque requirements, belt and pulley driven actuators typically require a gear reducer for optimum performance. Contact a THK Engineer for assistance.

Support Bearing Data

Table 5

GL size	Support Unit	Side	Axial Direction			Radial Direction	
			Basic dynamic load rating Ca N (lbf)	Permissible Load N (lbf)	Rigidity N/μm (lbf/μm)	Basic dynamic load rating C N (lbf)	Basic static load rating C ₀ N (lbf)
GL15	BK10	Fixed	6080 (1370)	3080 (692)	65 (15)	—	—
	BF10	Supported	—	—	—	3350 (753)	1400 (315)
GL20	BK12	Fixed	6660 (1500)	3240 (728)	88 (20)	—	—
	BF12	Supported	—	—	—	4550 (1020)	1960 (441)

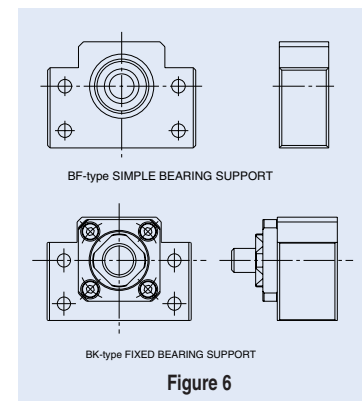
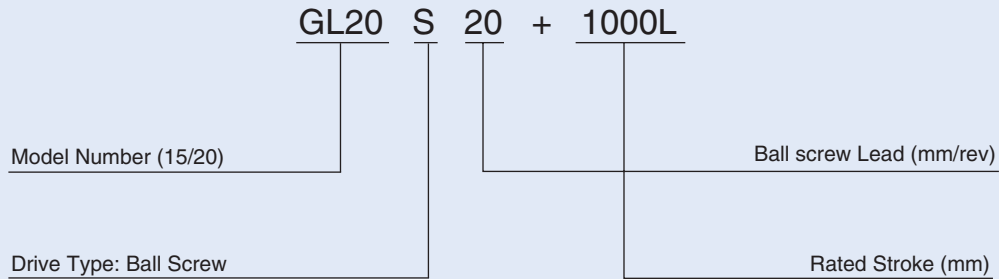

Figure 6

Model Number Coding

Ball Screw Drive



Belt Drive

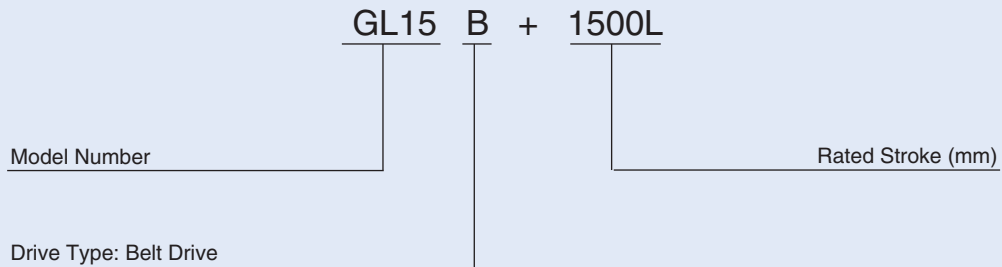

* Note: Previously available options, such as bellows and electromagnetic brakes, have now been classified as “**ME-Standard Options**”. See pages 17-18 for details.

Figure 7

Standard Stroke Lengths

GL15S & GL20S Ball Screw Drive Type*

Table 6 o Standard available

	Model	GL15S		GL20S		
	Screw Lead	5mm	16mm	5mm	20mm	40mm
STROKE mm (inch)	200 (8)	o		o		
	300 (12)	o		o		
	400 (16)	o		o		
	500 (20)	o	o	o	o	
	600 (24)		o		o	
	800 (32)		o		o	
	100 (40)		o		o	o
	1250 (50)		o		o	o
	1500 (60)		o		o	o
	1750 (70)				o	o
	2000 (80)				o	o

GL15B & GL20B Belt Drive Type*

Table 7 o Standard available

	Model	GL15B	GL20B
	STROKE mm (inch)	300 (12)	o
500 (20)		o	o
750 (30)		o	o
1000 (40)		o	o
1250 (50)		o	o
1500 (60)		o	o
1750 (70)		o	o
2000 (80)		o	o
2500 (100)			o
3000 (120)			o

* Note: Custom rated stroke lengths and leads (from standard available GL leads) available upon request.

Drive Data

Ball Screw Data

Table 8

Model	GL15S05	GL15S16	GL20S05	GL20S20	GL20S40
Static Load Rating	13.3 kN	14.3 kN	16.5 kN	24.7 kN	13.6 kN
Dynamic Load Rating	5.4 kN	7.1 kN	6.0 kN	11.1 kN	5.4 kN
Shaft Dia. (mm)	16	16	20	20	20
Lead (mm/rev.)	5	16	5	20	40
Breakaway Torque	< 0.1 N-m				
Accuracy Grade	C10				
Axial Clearance	< 0.1 mm				

SI Unit: 1 kN is approx. 224.8 lbs.
1 N-m is approx. 141.6 oz-in

Ball Screw Length

Table 9

(mm)

Standard Stroke	Model: GL15S	Model: GL20S
200	406	440
300	506	540
400	606	640
500	706	740
600	806	840
800	1006	1040
1000	1206	1240
1250	1456	1490
1500	1706	1740
1750	N/A	1990
2000	N/A	2240

Maximum Speed Data for Ball Screw Drive

Figure 8

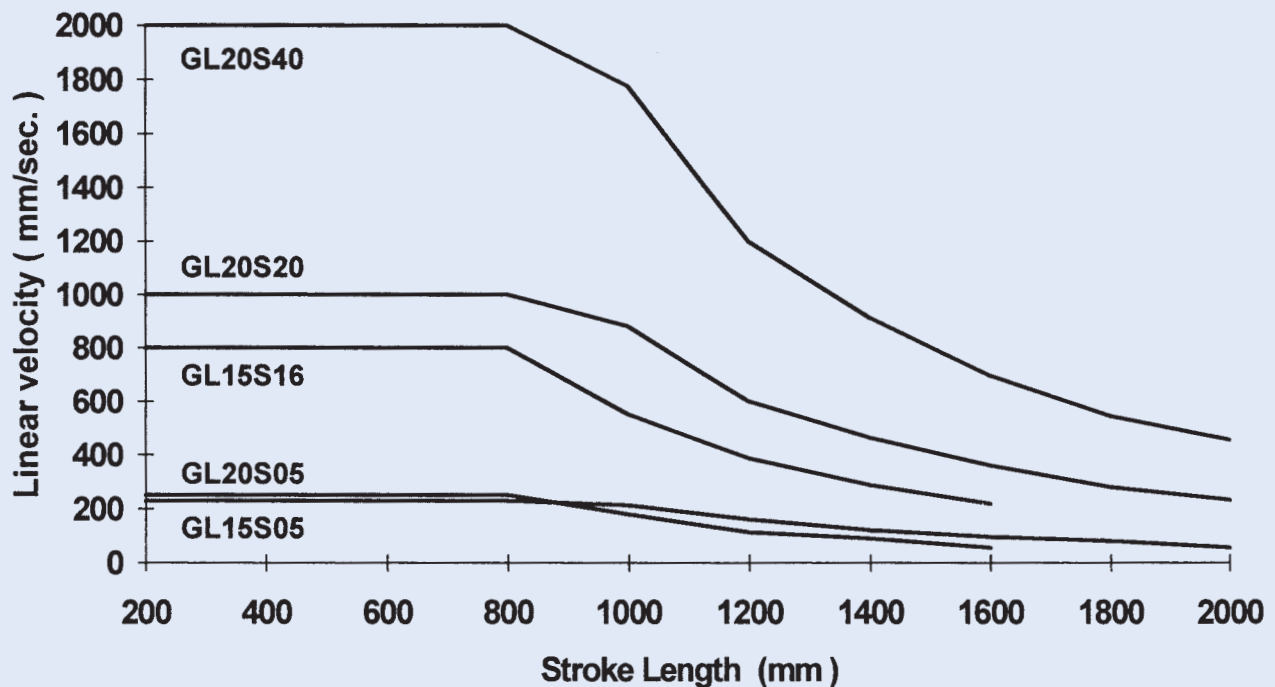

Drive Data

■ Belt & Pulley Data

Table 10

Attribute	Model GL15B	Model GL20B
Belt Type	S5M-25, Zero Backlash	S5M-25, Zero Backlash
Material	Steel reinforced polyurethane	Steel reinforced polyurethane
Tooth Pitch	5.0 mm	5.0 mm
Belt Weight/1000 mm	0.0819 kg	0.0819 kg
Pulley Diameter	35.01 mm	38.2 mm
Drive Pulley Inertia	0.000046 kg•m ²	0.000056 kg•m ²
Idler Pulley Inertia	0.000041 kg•m ²	0.000052 kg•m ²

■ Standard Reducer Data

Table 11

Model #	GL NE23-XX	GL NE34-XX	GL PX23-XX	GL PX34-XX
Reducer Type*	In-Line Spur Type**	In-Line Spur Type**	Helical Planetary***	Helical Planetary***
Standard Red. Ratios	3:1, 5:1, 10:1	3:1, 5:1, 10:1	3:1, 5:1, 10:1	3:1, 5:1, 10:1
Rated Output Torque (N•m)	6	28	34	90
Rated Input Speed (rpm)	4000	4000	5000	4000
Average Efficiency	92%	92%	90%	90%
Moment of Inertia (kg•m ²)	0.0000005	0.000004	0.000011	0.00002
Max. Backlash (arcmin)****	20	20	15	15
Reducer Weight (kg)	0.5	1.4	2	3

* Right-angle reducers also available, contact your THK Engineer for more information.

** 1/4" clamp-on pinion provided for GL NE23-XX type; 3/8" clamp-on pinion provided for GL NE34-XX type; contact THK for non-NEMA motors.

*** Motor P/N must be specified upon order to insure receipt of proper mounting flange & bushing (unless matching NEMA-type).

**** Low backlash (10 arcmin. available). Contact a THK Engineer for more information.

■ Reducer Mounting Configuration

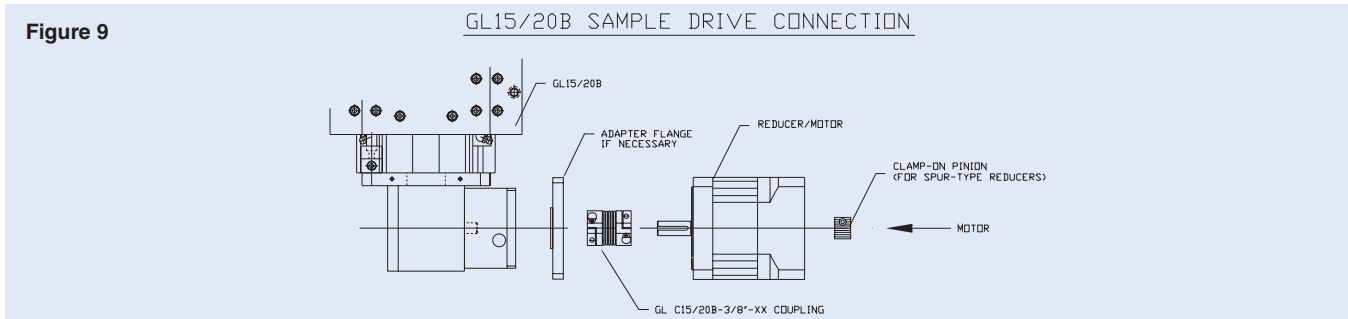

■ Assembly Weight*

Table 12

Unit: kg (lb)

Stroke (mm)	GL15S		GL15B		GL20S		GL20B	
200	6.8	(15.0)	–	–	10.1	(22.3)	–	–
300	7.8	(17.1)	9.5	(20.9)	11.4	(25.1)	13.7	(30.2)
400	8.7	(19.1)	–	–	12.7	(28.0)	–	–
500	9.6	(21.1)	11.1	(24.5)	14.0	(30.9)	16.0	(35.2)
600	10.6	(23.3)	–	–	15.3	(33.7)	–	–
750	–	–	13.1	(29.0)	–	–	18.7	(41.1)
800	12.4	(27.3)	–	–	17.9	(39.4)	–	–
1000	14.3	(31.4)	15.2	(33.5)	20.5	(45.1)	21.4	(47.1)
1250	16.6	(36.6)	17.3	(38.0)	23.7	(52.3)	24.2	(53.2)
1500	18.1	(39.8)	18.3	(40.4)	26.1	(57.4)	25.9	(57.1)
1750	–	–	20.2	(44.6)	29.2	(64.3)	28.5	(62.9)
2000	–	–	22.2	(48.8)	32.3	(71.1)	31.2	(68.6)
2500	–	–	–	–	–	–	36.4	(80.2)
3000	–	–	–	–	–	–	41.6	(91.7)

*Complete unit including LM Guide, base extrusion, and all other components.

■ Base Rigidity

Table 13

Base	I _x (mm ⁴)	I _y (mm ⁴)
GL15	2.05 x 10 ⁵	2.72 x 10 ⁶
GL20	4.60 x 10 ⁵	4.65 x 10 ⁶

Figure 10

I_x: Geometrical moment of inertia around X axis

I_y: Geometrical moment of inertia around Y axis

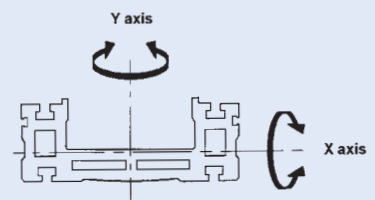

1/4-20 UNC w/ thread inserts 4 places w/
 ø11 dia. c-bore depth 6 from bottom side.
 (to mount the load from the back using an M5)

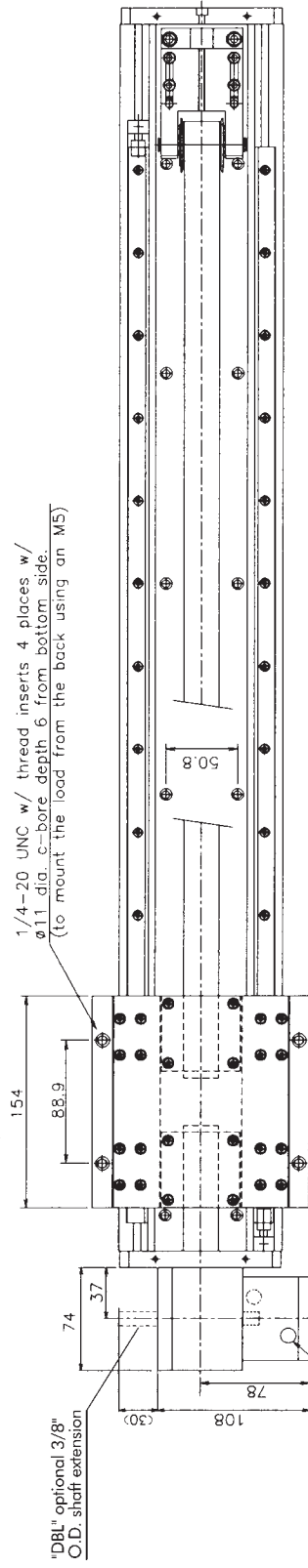

TOP VIEW SHOWN WITHOUT COVER

Check with THK for available motor adapter flanges

Aluminum cover (available only on strokes up to 1250L)

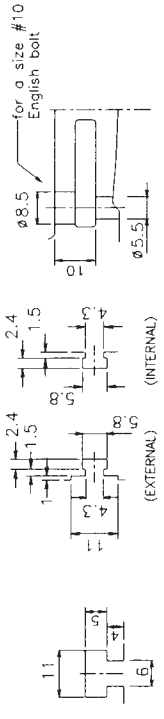
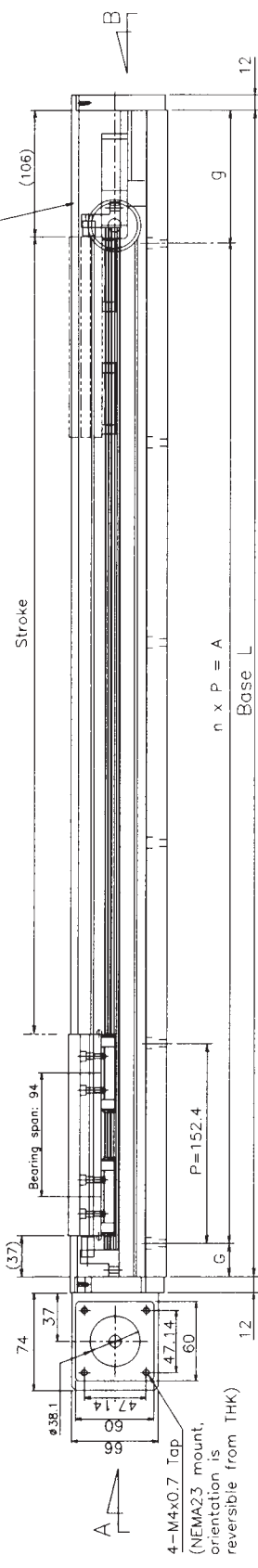

C detail D detail E detail F detail

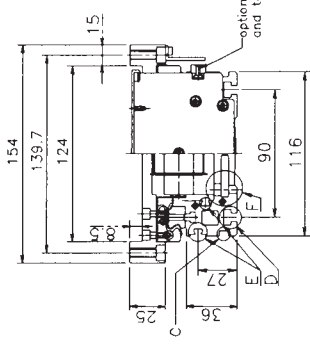

B View

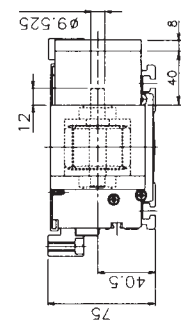

A View

Stroke	Base L	G	n x P = A	g
300	620	25.4	3x152.4=457.2	137.4
500	820	25.4	4x152.4=609.6	185
750	1070	25.4	6x152.4=914.4	130.2
1000	1320	25.4	7x152.4=1066.8	227.8
1250	1570	25.4	9x152.4=1371.6	173
1500	1820	25.4	11x152.4=1676.4	118.2
1750	2070	25.4	12x152.4=1828.8	215.8
2000	2320	25.4	14x152.4=2133.6	161

Units: mm

Model: GL15B

NOTE: The maximum available stroke for each unit is slightly more than the stated stroke. Summation of the dimensions from this drawing will indicate the maximum stroke within size and assembly tolerances.

Mounting Flanges/ Sensor Kits

Motor Mounting Flanges*

All GL15 and GL20 actuators have been designed to accommodate standard NEMA23 dimension motors & reducers without the use of additional mounting flanges.

For motors or reducers that have non-NEMA23 dimensions, THK has more than 50 different motor adapter flanges available for unit product actuators. They are available for immediate delivery.

For specific flange information and part numbers, contact a THK Engineer and reference the required mounting dimensions in Figures 11 through 14.

* Motor Couplings

THK offers a variety of motor couplings. Contact a THK Regional Engineer for the coupling best suited to your application.

Figure 11
GL F-TYPE FLANGE (STD)

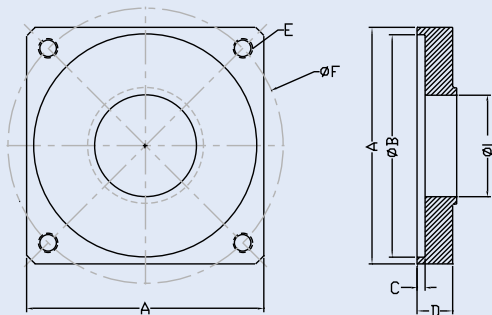
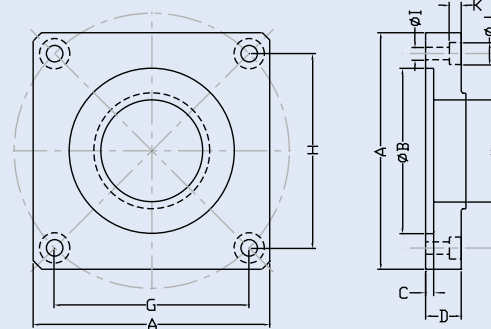

Figure 12
GL F-TYPE FLANGE (C-BORE)



GL FS-TYPE FLANGE (STD)

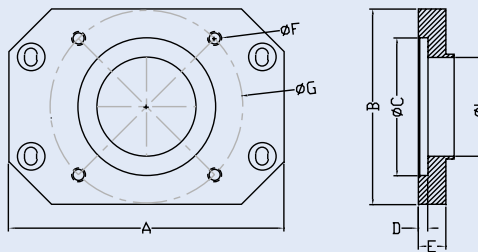

Figure 13

GL FS-TYPE FLANGE (C-BORE)

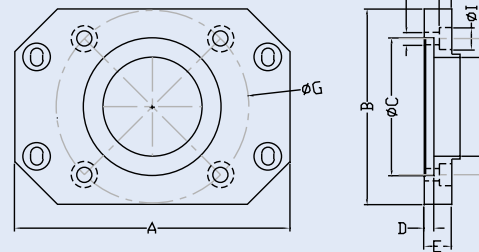

Figure 14

Proximity Sensor Kits

The base of the GL15 and GL20 linear actuators provides extruded T-slots for convenient end-of-travel and home sensor mounting locations. THK can provide two types of sensor kits (PNP or NPN logic) that mount directly to the T-slots located on either side of the linear actuator base.

Sensor Kit: GL SK-1N

Kit includes:

3 NPN inductive type proximity sensors (1 normally open, 2 normally closed)

1 sensor target to be mounted to the bottom side of the carriage plate as shown to the right

Sensor Kit: GL SK-1P

Kit includes:

3 PNP inductive type proximity sensors (1 normally open, 2 normally closed)

1 sensor target to be mounted to the bottom side of the carriage plate as shown to the right.

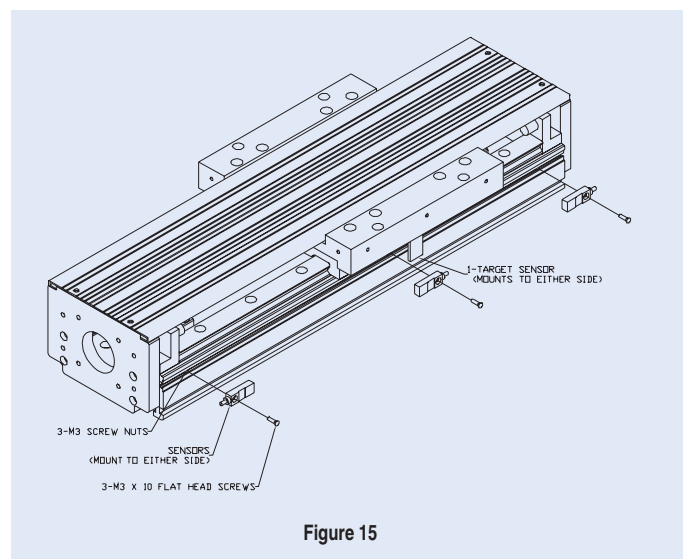

Figure 15

Note: Above kits include all necessary hardware. Proximity switches require a 12DC-24DC power source.

Bellows Covers

■ Bellows Covers

All GL series linear actuators can be ordered with optional bellows covers for applications requiring an extra degree of contamination protection. The bellows are made of high-quality thermic-weld PVC coated nylon with PVC stiffeners that prevent the bellows from sagging or buckling. Bellows can be ordered separately or installed on your GL unit using THK's standard ME-options (see pages 17-18). Contact your THK representative for pricing and delivery.

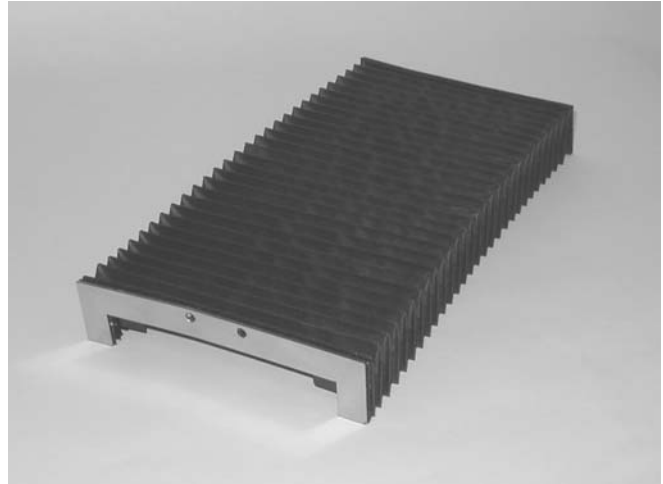

■ Approximate Actuator Stroke with Bellows Installed

Table 14

Standard Stroke Length (mm)	GL15S stroke w/ bellows	GL15B stroke w/ bellows	GL20S stroke w/ bellows	GL20B stroke w/ bellows
200	190	-	200	-
300	270	290*	285	300*
400	350	-	370	-
500	420	470	445	480
600	500	-	530	-
750	-	675	-	710
800	650	-	690	-
1000	810	870	850	920
1250	1000	1065	1050	1120
1500	1200	1260	1255	1320
1750	-	1450	1450	1515
2000	-	1640	1650	1720
2500	-	-	-	2125
3000	-	-	-	2525

* Use caution when incorporating bellows with smaller stroke GL units. End-of-travel stops are removed to accommodate bellows assembly. Bellows "Lc" (closed length) may be less than original end-of-travel stops.

ME-Standard Options

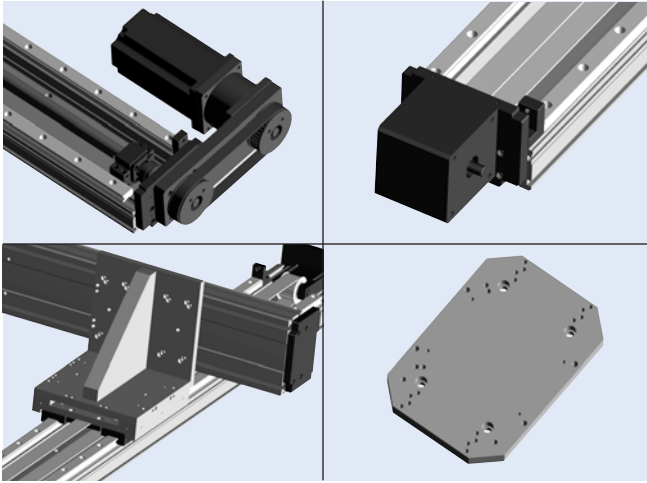

By using THK's pre-engineered standard options, you can reduce your company's initial design time and associated costs, leading to improved time-to-market productivity.

Choose from a multitude of interchangeable standard options to customize your GL actuator, including:

- Multi-axis mounting brackets
 - High performance, pre-selected "plug-and-play" servomotors and servo amplifiers
 - Carriage options - including dual carriages, steel carriages and opposing motion
 - Keyed input shafts and shaft extensions for gantry applications
 - Electromagnetic power-off holding brakes
 - NTDC "Armor" plating for added protection in severe environments
 - THK's exclusive pre-tensioned motor "wrap" designs for tight design spaces
- ...and many more.

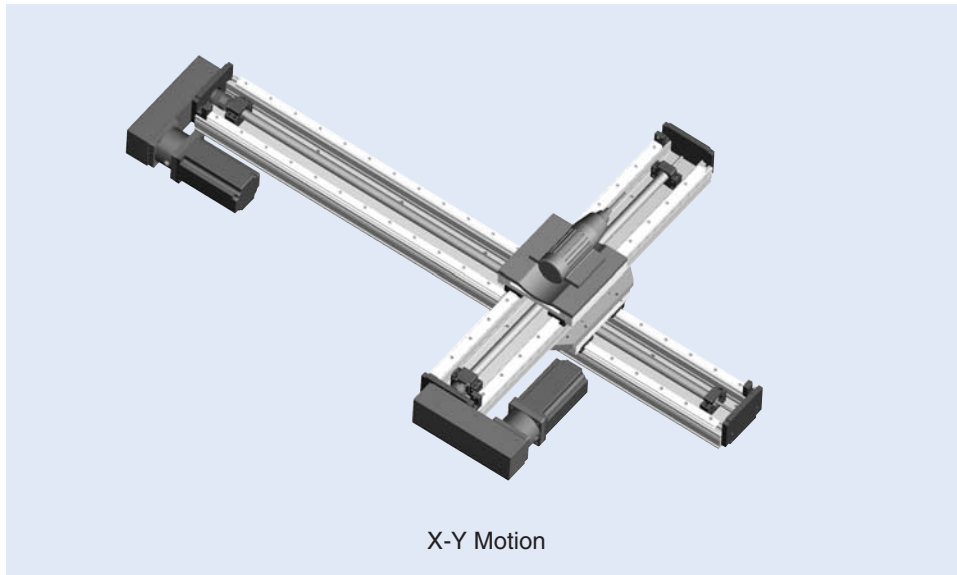

X-Y Motion

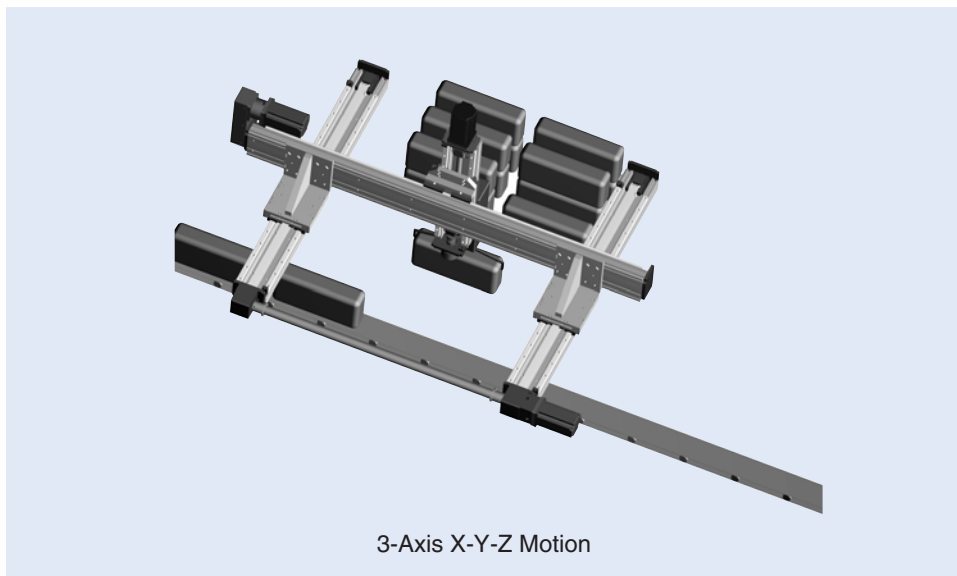

3-Axis X-Y-Z Motion

Unit Product Mounting Brackets

THK's revolutionary UPMB kits (Unit Product Mounting Brackets) allow you to build custom multi-axis positioning systems for your linear motion applications without the hassle of creating new components or modifying existing ones. Contact your THK representative for application assistance, part numbers, and pricing.

- UPMB kit stock availability for immediate delivery and low cost.
- Six different mounting configurations.
- Compatible with GL15 & GL20 models for maximum interchangeability.
- Limitless 2-axis & gantry configurations via the GL extrusion T-slots for maximum adjustability.
- Rigid construction.
- Ready-made fastener kits with custom T-slot nuts available for quick installation (sold separately).

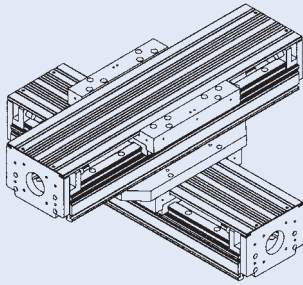

Carriage-to-Base XY configuration

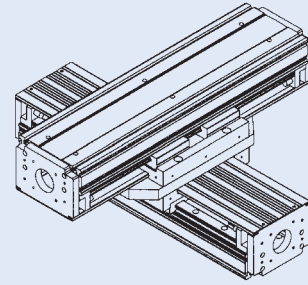

Carriage-to-Carriage XY configuration

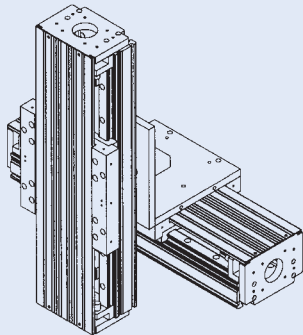

Carriage-to-Base XZ configuration (side mounted)

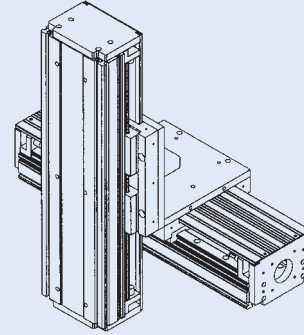

Carriage-to-Carriage XZ configuration (side mounted)

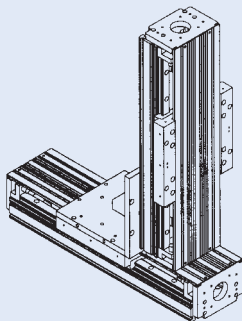

Carriage-to-Base Inline XZ configuration

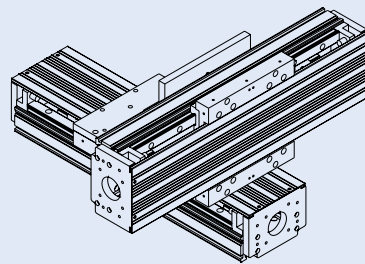

Carriage-to-Base 90° XY configuration

ME-Standard Options

Use THK's ME-Standard Options for GL actuators to build your own linear positioning systems without the hassle of having to design them from scratch. From ready-made UPMB multi-axis interface brackets to N.T.D.C. "armor-plated" systems for severe environments, THK has your system needs covered. Contact your THK representative for more information.

■ Dual Axis Automation System with Ball Screw Actuators

Example #1 - Dual Axis General Automation System with N.T.D.C "Armor" Plating

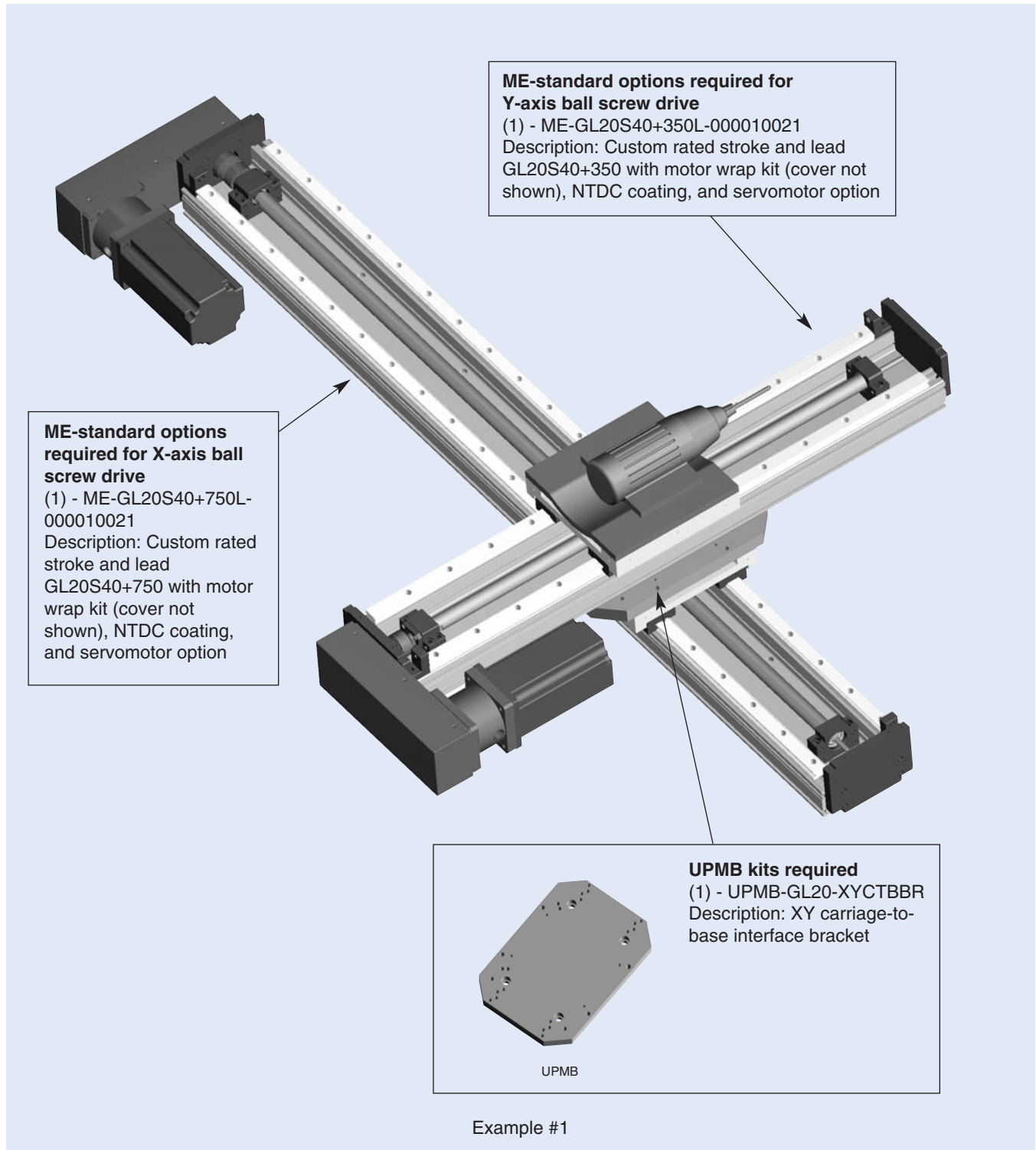

Note - necessary couplings and motor adapter flanges not detailed here. Contact your THK representative for more details.

ME-Standard Options

■ 3-Axis Gantry with Ballscrew and Belt Drive Actuators

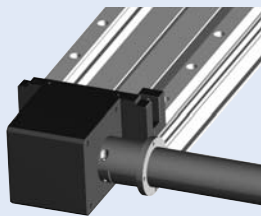

NMB option

ME-standard option required for X-axis belt-drive
 (1) - ME-GL20B+700L-10000000
 Description: Standard GL20B+700L with NMB shaft option (for gantry applications)
 *Drive shaft not included

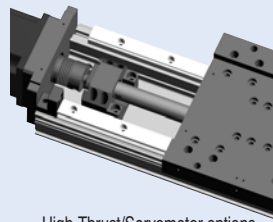

High-Thrust/Servomotor options

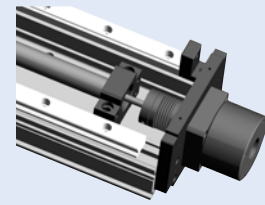

External EMB option

ME-standard option required for Z-axis ballscrew drive
 (1) - ME-GL20S05+350L-100200001
 Description: Custom rated stroke GL20S05 with high-thrust, external holding brake, and servomotor options

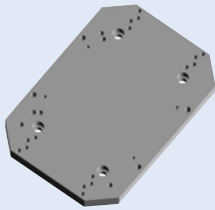

UPMB-GL20-XYCTCBBR

UPMB kit required
 (1) - UPMB-GL20-XYCTCBBR
 Description: XY carriage-to-carriage interface bracket

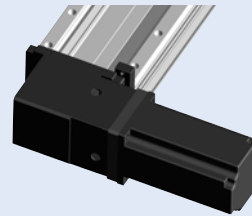

Servomotor option

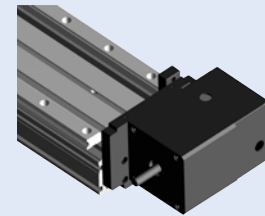

Extended Shaft option

ME-standard options required for X-axis belt drives
 (1) - ME-GL20B+700L-000020100
 Description: Standard GL20B+700L with extended shaft option (for gantry applications) and servomotor option

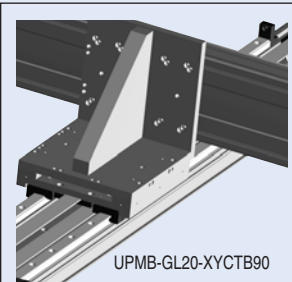
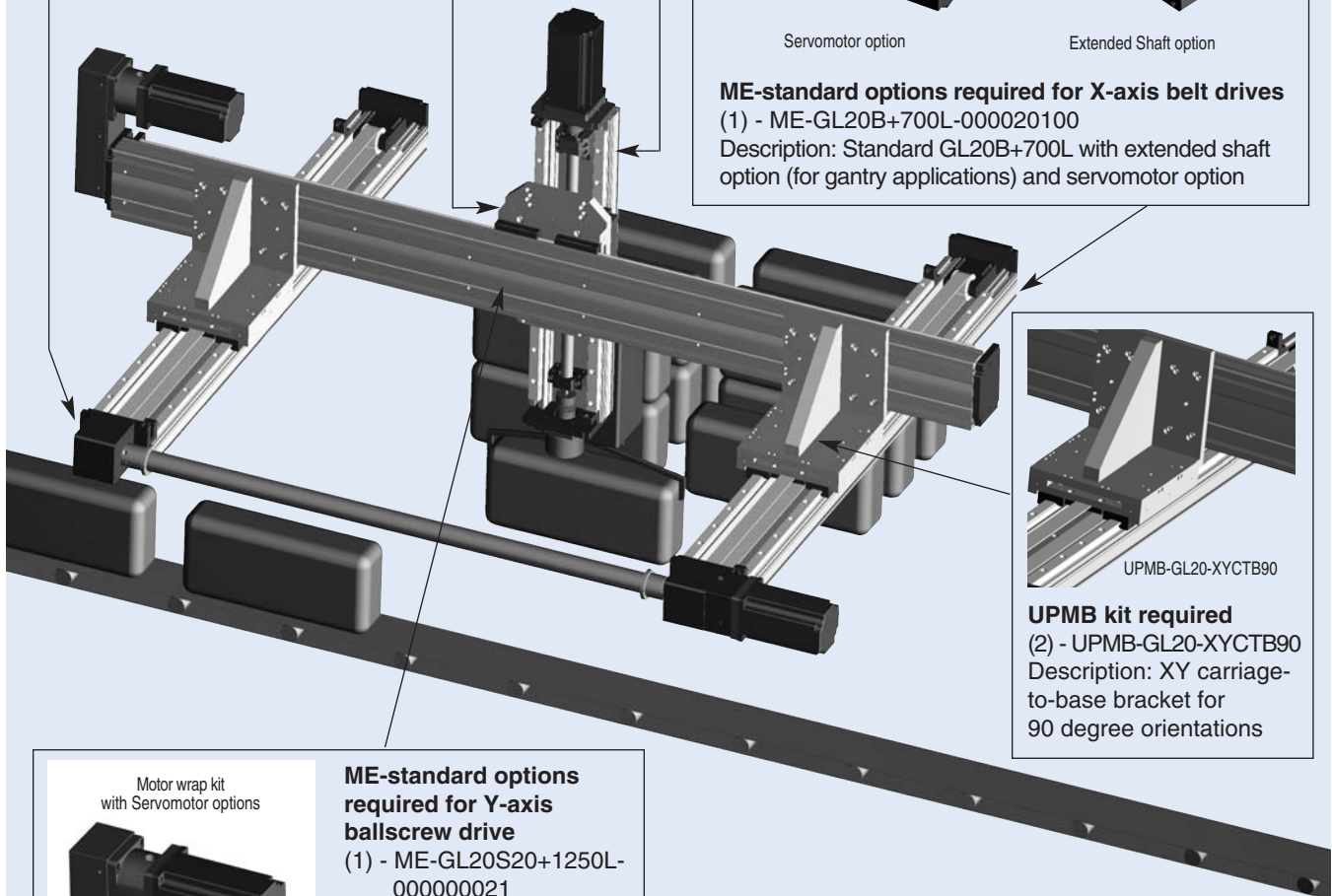

UPMB-GL20-XYCTB90

UPMB kit required
 (2) - UPMB-GL20-XYCTB90
 Description: XY carriage-to-base bracket for 90 degree orientations

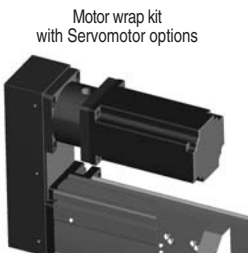

Motor wrap kit with Servomotor options

ME-standard options required for Y-axis ballscrew drive
 (1) - ME-GL20S20+1250L-000000021
 Description: Standard GL20S20+1250L with motor wrap kit and servomotor option

Example #2

Note - necessary couplings and motor adapter flanges not detailed here. Contact your THK representative for more details.

ME-Standard Options

■ Dual Axis/Carriage, Opposing Motion Spraying System

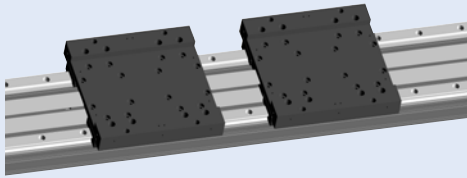

Dual carriage (AL) opposing motion option

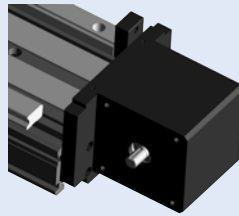

1/8" keyed input shaft option

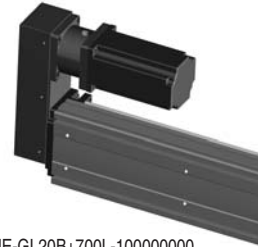

ME-GL20B+700L-100000000

ME-standard options required for X-axis

(1) - ME-GL20B+1750L-040050100

Description: Custom rated stroke GL20B+1275L with opposing motion AL carriages, reversed motor input direction, keyed shaft, and servomotor

ME-standard options required for Z-axes

(2) - ME-GL15S16+350L-000200021

Description: Custom rated stroke and lead GL15S16 with motor wrap kit, external brake, and servomotor option

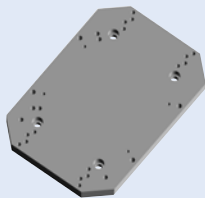
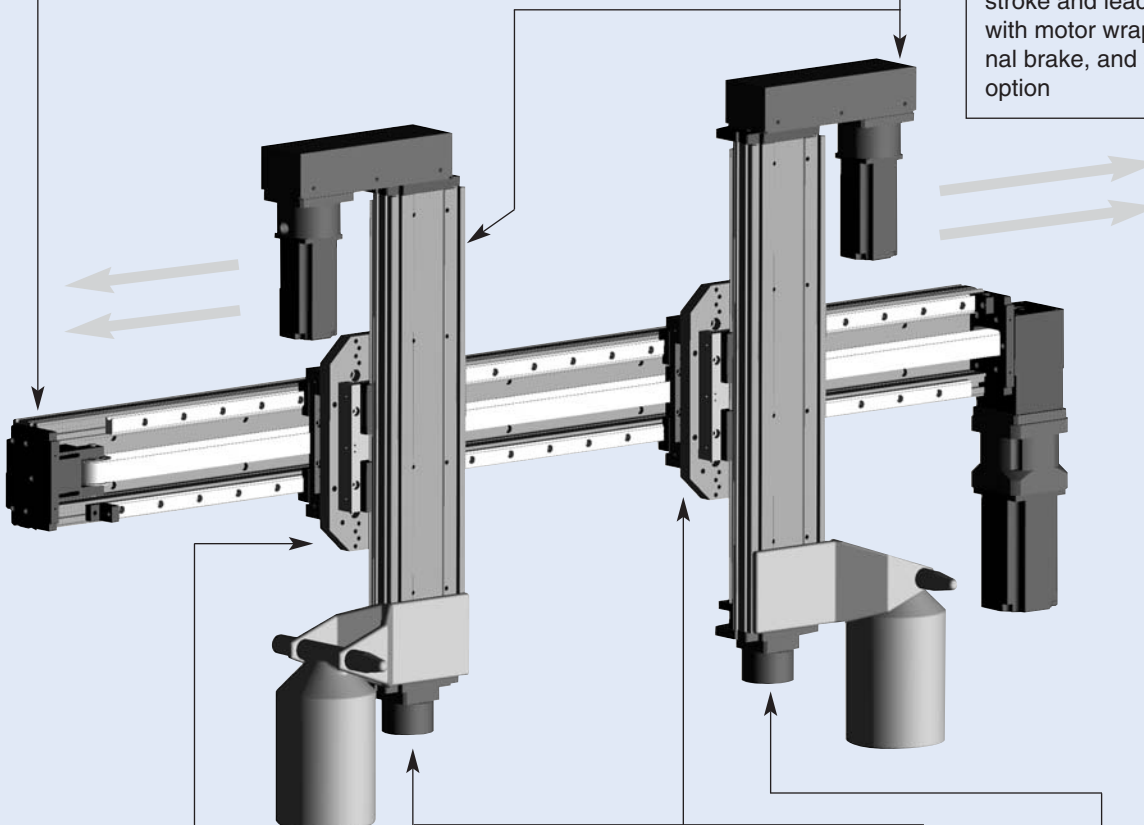

UPMB

UPMB kits required

(2) - UPMB-GL20-XYCTCBR

Description: XY carriage-to-carriage interface bracket

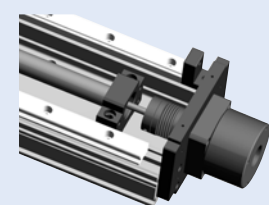

External EMB option

Example #3

Note - necessary couplings and motor adapter flanges not detailed here. Contact your THK representative for more details.

GL Ball Screw Driven Actuators

ME-Standard Options For GL Ball Screw Driven Actuators

- Custom Performance at Minimal Cost
- Multiple Options Can Be Combined for Maximum Versatility
- Stocked Components, Immediate Availability

THK's ME-Standard Options for GL Ball screw Driven Actuators can help give your application the edge over your competition by providing custom-tailored options for your GL unit at minimal cost. From N.T.D.C. "armor-plate" options for severe environments to custom rated stroke lengths and specialized lubrication, THK has ME-Standard Options to suit your application's particular needs. Options from all component sub-headings are compatible with one another, giving you almost limitless flexibility when ordering. Contact your THK representative for specifications, pricing, delivery, and ordering information.

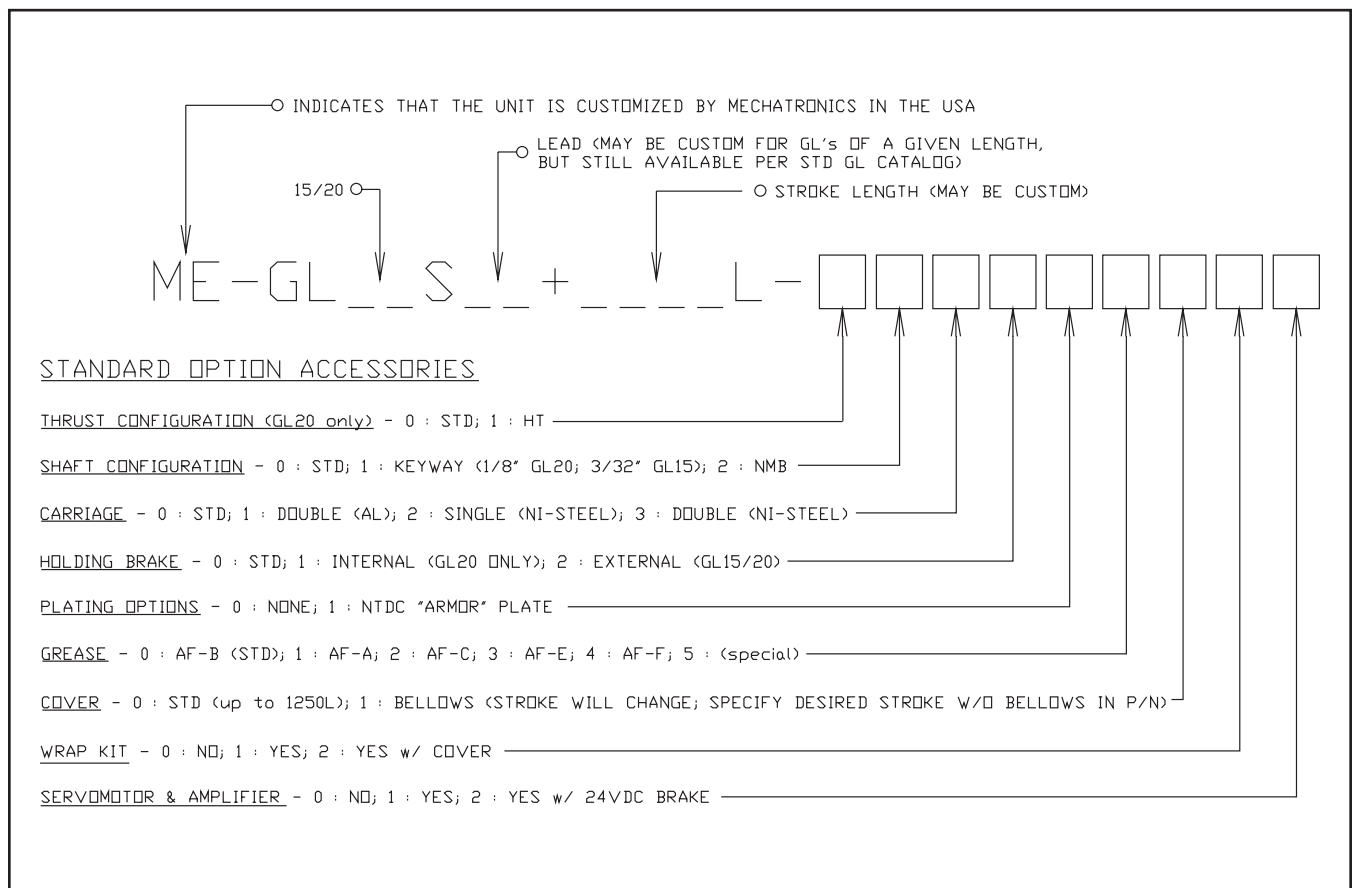

GL Belt Driven Actuators

ME-Standard Options For GL Belt Driven Actuators

- Custom Performance at Minimal Cost
- Multiple Options Can Be Combined for Maximum Versatility
- Stocked Components, Immediate Availability

THK's ME-Standard Options for GL Belt Driven Actuators can help give your application the edge over your competition by providing custom-tailored options for your GL unit at minimal cost. From gantry-ready configurations to dual carriage opposing motion, THK has ME-Standard Options to suit your application's particular needs. Options from all component sub-headings are compatible with one another, giving you almost limitless flexibility when ordering. Contact your THK representative for specifications, pricing, delivery, and ordering information.

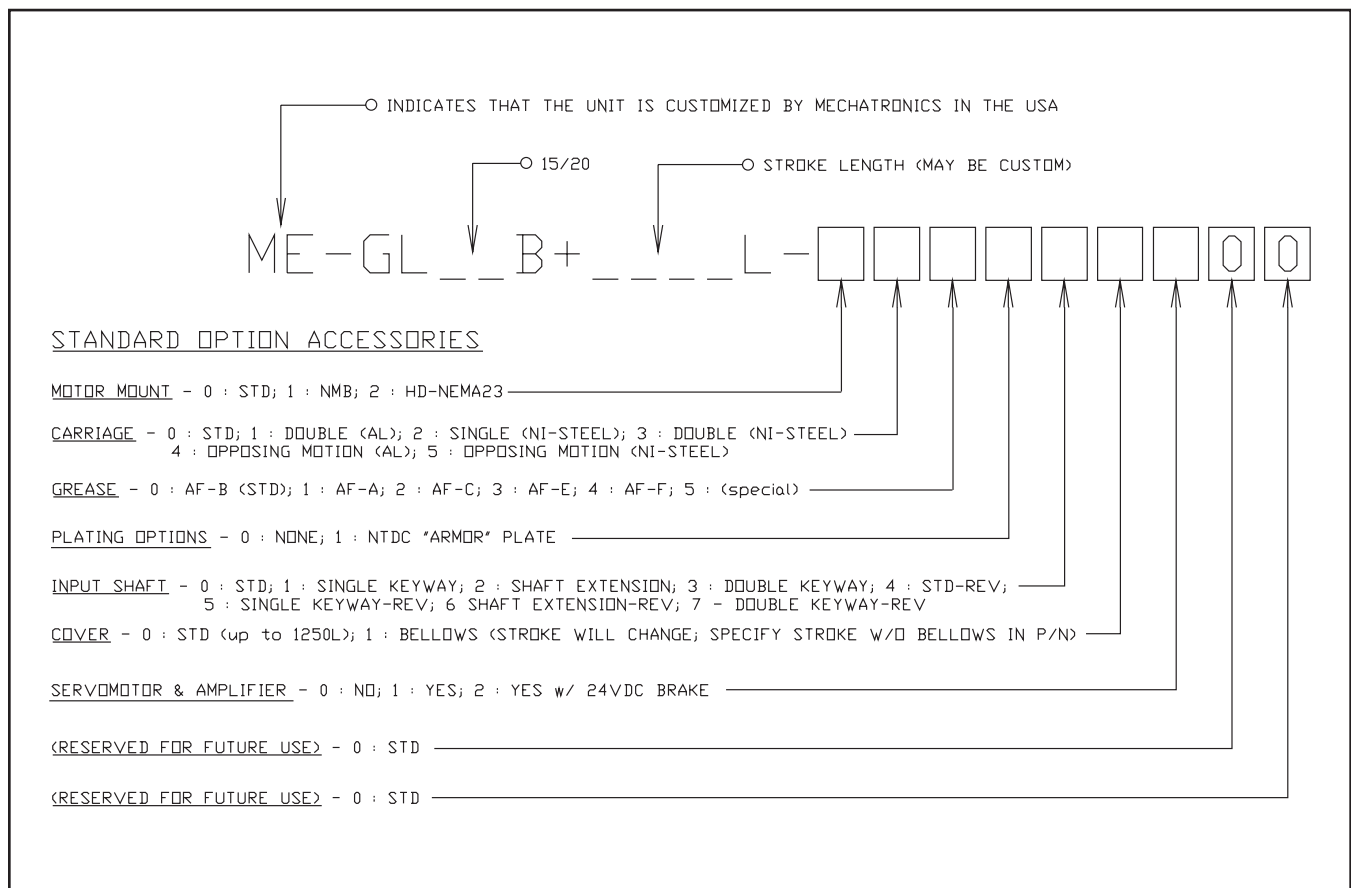

Note: This Catalog provides basic information relating to THK linear motion and related products. The Catalog, including all information, charts, formulas, factors, accuracy standards, tolerances and applications recommendations contained herein, is only a starting point for the customer's selection of appropriate products, and may not apply in all intended applications. The Catalog is not a substitute for a proper application analysis conducted by an experienced, knowledgeable design engineer. Product selection should be based upon your specific application needs and conditions, which will vary greatly depending on many factors. No specific product application should be based solely on the information contained in this Catalog. All purchases of THK Products are subject to THK America's and the manufacturer's limited warranty. Customers should confirm independently that a contemplated application is safe, appropriate and effective.

THK Linear Slide Type GL



Specifications are subject to change without notice.

THK **T H K CO., LTD.**
www.thk.com

• **THK AMERICA, INC.**

HEADQUARTERS

200 East Commerce Drive, Schaumburg, IL 60173
Phone: (847) 310-1111 Fax: (847) 310-1271

CHICAGO REGIONAL OFFICE

200 East Commerce Drive, Schaumburg, IL 60173
Phone: (847) 310-1111 Fax: (847) 310-1182

NEW JERSEY REGIONAL OFFICE

300 F, RT. 17, South, Mahwah, NJ 07430
Phone: (201) 529-1950 Fax: (201) 529-1962

ATLANTA REGIONAL OFFICE

6135-E Northbelt Drive, Norcross, GA 30071
Phone: (770) 840-7990 Fax: (770) 840-7897

LOS ANGELES REGIONAL OFFICE

6000 Phyllis Drive, Cypress, CA 90630
Phone: (714) 891-6752 Fax: (714) 894-9315

SAN FRANCISCO REGIONAL OFFICE

4603 Las Positas Road #E, Livermore, CA 94550
Phone: (925) 455-8948 Fax: (925) 455-8965

• **THK CANADA**

(Division of THK AMERICA, Inc.)

130 Matheson Blvd. East #1
Mississauga, ON L4Z 1Y6
Phone: (905) 712-2922 Fax: (905) 712-2925