SURE-FLEX[®]

ELASTOMERIC

COUPLINGS

- **Need No Lubrication, No Maintenance**
- **Quick, Easy Installation**
- **Clean, Quiet Performance**



4-WAY FLEXING ACTION absorbs all types of shock, vibration and misalignment

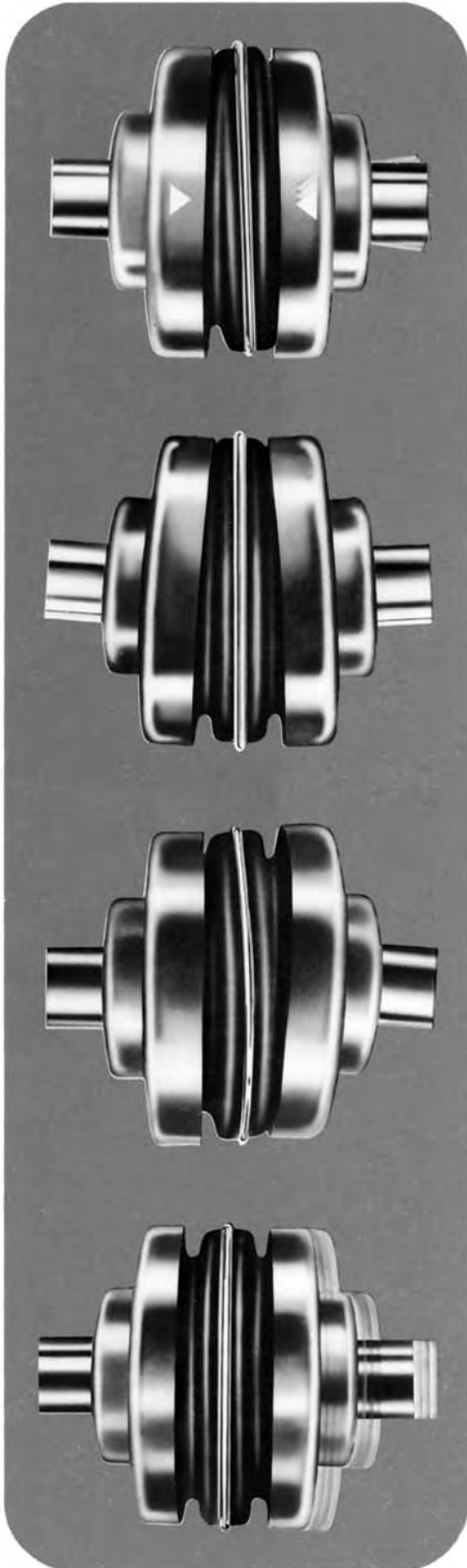

TORSIONAL

Sure-Flex coupling sleeves have an exceptional ability to absorb torsional shock and dampen torsional vibrations. The EPDM and Neoprene sleeves wind-up approximately 15° torsionally at their rated torque. Hytrel sleeves will wind-up about 7°.

ANGULAR

The unique design of the Sure-Flex coupling's teeth allows for the absorption of angular misalignment without wear. Refer to page F1—18 for actual allowable misalignment limits. These limits allow for the alignment of the coupling using only a scale and calipers.

PARALLEL

Parallel misalignment is absorbed without wear or appreciable energy losses. The lateral flexibility of the coupling sleeve minimizes radial bearing loads normally associated with parallel misalignment. This feature also allows for easier installation by the use of components bored for slip fits without fretting corrosion occurring at the shaft. Refer to page F1—18 for parallel misalignment limits. Only a straight-edge and feeler gage are required to obtain these limits.

AXIAL

Sure-Flex couplings may be used in applications with limited axial shaft movements. The axial compressibility of the EPDM and Neoprene sleeves allows for shaft end-float without the absolute transfer of thrust loads.



EASY, QUICK INSTALLATION

Sure-Flex can be installed quickly and easily, because there are no bolts, gaskets, covers or seals. Alignment can be checked with a straightedge placed across the outside of the precision-machined flanges. No special tools are needed for installation, alignment or removal.



NO LUBRICATION, TROUBLE-FREE OPERATION

The teeth of the sleeve lock into the teeth of the flanges without clamps or screws, tightening under torque to provide smooth transmission of power. There is no rubbing action of metal against rubber to cause wear. Couplings are not affected by abrasives, dirt, or moisture. This eliminates the need for lubrication or maintenance, provides clean, dependable, quiet performance.

SURE-FLEX SELECTION

Sure-Flex couplings are selected as component parts.

1. Determine SLEEVE material and type.
Refer to pages F1—4 & 5
2. Determine coupling SIZE.
Refer to pages F1—6, 7, & 8
3. Determine FLANGES to be used.
Refer to pages F1—9 thru 16

Specify coupling components.

- Example #1 - Close coupled
 - Size 6, Type S flange w 1-3/8 bore
 - Size 6, Type S flange w 1" bore
 - Size 6, Solid EPDM sleeve
- Example #2 - 5" Between shaft spacer
 - Size 9, Type SC flange for #11 hub
 - Size 9, Type SC flange for #9 hub
 - Size 11 hub w 2-3/8 bore
 - Size 9 short hub w 1-1/8 bore
 - Size 9 Solid Hytrel sleeve

PROD. NUMBER	PROD. DESCRIPTION
6S138	6Sx1-3/8
6S1	6Sx1
6J	6JE
9SC5011	9SC50-11
9SC50	9SC50
11SCH238	11SCH x 2-3/8
9SCHS118	9SCHS x 1-1/8
9H	9H



SURE-FLEX SLEEVE SELECTION

Sure-Flex Sleeves are available in four materials or compounds and various shape configurations.

	EPDM	Neoprene	Hytrel	Urethane
CONSTRUCTIONS AVAILABLE 1 pc, unsplit 1 pc, split 2 piece	JE JES E	JN JNS N	H — HS	U — —
TYPICAL USE	General Purpose	Oil Resist Non-flame	General Purpose	Stiffness
REL. RATING WIND-UP ANGULAR MISALIGN	1X 15° 1°	1X 15° 1°	4X 7° 1/4°	4X 3° 1/4°
TEMPERATURE (F) maximum minimum	+275° -30°	+200° -0°	+250° -65°	+200° -80°

SURE-FLEX SLEEVES

Product No.	Product Description
3J	3JE EPDM
4J	4JE EPDM
5J	5JE EPDM
6J	6JE EPDM
7J	7JE EPDM
8J	8JE EPDM
9J	9JE EPDM
10J	10JE EPDM
3JS	3JES EPDM Split
4JS	4JES EPDM Split
5JS	5JES EPDM Split
6JS	6JES EPDM Split
7JS	7JES EPDM Split
8JS	8JES EPDM Split
9JS	9JES EPDM Split
10JS	10JES EPDM Split
3JN	3JN Neoprene
4JN	4JN Neoprene
5JN	5JN Neoprene
6JN	6JN Neoprene
7JN	7JN Neoprene
8JN	8JN Neoprene
3JNS	3JNS Neoprene Split
4JNS	4JNS Neoprene Split
5JNS	5JNS Neoprene Split
6JNS	6JNS Neoprene Split
7JNS	7JNS Neoprene Split
8JNS	8JNS Neoprene Split







Product No.	Product Description
4	4E EPDM
5	5E EPDM
6	6E EPDM
7	7E EPDM
8	8E EPDM
9	9E EPDM
10	10E EPDM
11	11E EPDM
12	12E EPDM
13	13E EPDM
14	14E EPDM
16	16E EPDM
4N	4N Neoprene
5N	5N Neoprene
6N	6N Neoprene
7N	7N Neoprene
8N	8N Neoprene
9N	9N Neoprene
10N	10N Neoprene
11N	11N Neoprene
12N	12N Neoprene
13N	13N Neoprene
14N	14N Neoprene

Product No.	Product Description
6H	6H Hytrel
7H	7H Hytrel
8H	8H Hytrel
9H	9H Hytrel
10H	10H Hytrel
11H	11H Hytrel
12H	12H Hytrel
6HS	6HS Split Hytrel
7HS	7HS Split Hytrel
8HS	8HS Split Hytrel
9HS	9HS Split Hytrel
10HS	10HS Split Hytrel
11HS	11HS Split Hytrel
12HS	12HS Split Hytrel
13HS	13HS Split Hytrel
14HS	14HS Split Hytrel
10U	10U Urethane
11U	11U Urethane
12U	12U Urethane

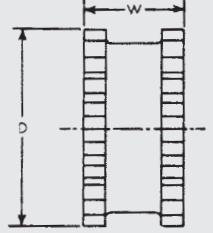
SURE-FLEX SLEEVE SELECTION

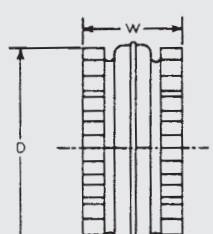

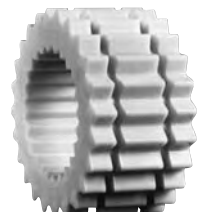
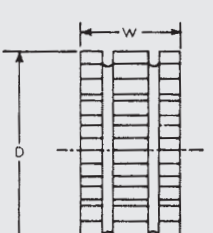
Flexible sleeves for Wood's Sure-Flex couplings are available in four materials (EPDM Neoprene, Hytrel and Urethane) and in three basic constructions. Characteristics of the materials are given on page F1—4 and the various types are shown and described here.

 <p>JE, JN</p>		 <p>Types JES, JNS</p>	<p>JE-JES-JN-JNS</p> <p>J sleeves are molded EPDM rubber (E) or Neoprene (N). They are available in one-piece solid construction (JE, JN) or one-piece split construction (JES, JNS). These sleeves may be used in any Sure-Flex flange within a given size.</p>
 <p>E and N (Assembled)</p>		 <p>Types E and N (Disassembled)</p>	<p>E-N</p> <p>These sleeves are of two-piece design with a retaining ring. They are available in either EPDM (E) or Neoprene (N). They may be used with any flange within a given size. Sleeves are shown here assembled and disassembled.</p>
 <p>H or U</p>		 <p>HS</p>	<p>H-HS-U</p> <p>H (Hytrel) and U (Urethane) sleeves, designed for high-torque applications, transmit four times as much power as an equivalent EPDM or Neoprene sleeve. Available in one-piece solid construction (H or U) or two-piece split construction (HS), these can be used only with S, C and SC flanges. They cannot be used with J or B flanges or as direct replacements for EPDM or Neoprene sleeves.</p>

DIMENSIONS (in.)

Coupling Size	JE, JES, JN & JNS Sleeves EPDM & Neoprene			E and N Sleeves EPDM & Neoprene			H, U & HS Sleeves Hytrel & Urethane		
	D	W	Wt. (lbs.)	D	W	Wt. (lbs.)	D	W	Wt. (lbs.)
3	1 7/8	1	.06
4	2 5/16	1 1/4	.10	2 5/16	1 1/4	.11
5	2 15/16	1 9/16	.20	2 15/16	1 9/16	.25
6	3 3/4	1 7/8	.40	3 3/4	1 7/8	.49	3 3/4	1 7/8	.44
7	4 11/32	2 3/16	.62	4 11/32	2 3/16	.77	4 11/32	2 3/16	.69
8	5 1/16	2 1/2	1.13	5 1/16	2 1/2	1.4	5 1/16	2 1/2	1.4
9*	6	3	1.46	6	3	2.0	6	3	1.8
10*	7 1/16	3 7/16	2.32	7 1/16	3 7/16	3.2	7 1/16	3 7/16	2.9
11	8 3/16	4	5.1	8 3/16	4	4.5
12	9 9/16	4 11/16	8.1	9 9/16	4 11/16	7.3
13	11 3/16	5 1/2	13.0	11 3/16	5 1/2	11.8
14	13 3/32	6 1/2	21.1	13 3/32	6 1/2	19.3
16	17 29/32	8 3/4	45.3

The 13 and 14 Hytrel available with HS sleeves only.

*All 9J and 10J sleeves available in EPDM only.

Only sizes available in Urethane.



SURE-FLEX COUPLING SIZE SELECTION

1. Select Load Symbol based on your driveN machine.

Application	Load Symbol	Application	Load Symbol	Application	Load Symbol
AGITATORS—Paddle, Propeller, Screw	L	DEWATERING SCREEN (sewage)	M	MILLS	
BAND RESAW (lumber)	M	DISC FEEDER	L	Ball, Pebble, Rod, Tube, Rubber Tumbling	H
BARGE HAUL PULLER	H	DOUGH MIXER	M	Dryer and Cooler	M
BARKING (lumber)	H	DRAW BENCH CONVEYOR and		MIXERS	
BAR SCREEN (sewage)	L	MAIN DRIVE	H	Concrete, Muller	M
BATCHES (textile)	L	DREDGES		Banbury	H
BEATER AND PULPER (paper)	M	Cable Reel, Pumps	M	ORE CRUSHER	H
BENDING ROLL (metal)	M	Cutter Head Drive, Jig Drive, Screen Drive	H	OVEN CONVEYOR	L
BLEACHER (paper)	L	Maneuvering and Utility Winch, Stackers	M	PLANER (metal or wood)	M
BLOWERS		DYNAMOMETER	L	PRESSES	
Centrifugal, Vane	L	DRYERS (rotary)	M	Brick, Briquette Machine	H
Lobe	M	EDGER (lumber)	H	Notching, Paper, Punch, Printing	M
BOTTLING MACHINERY	L	ELEVATOR		PUG MILL	M
BREW KETTLES (distilling)	L	Bucket	M	PULP GRINDER (paper)	H
BUCKET ELEVATOR OR CONVEYOR	M	Escalator	L	PULVERIZERS	
CALENDERS		Freight, Passenger, Service, Man Lift	H	Hammermill—light duty, Roller	M
Calendar (paper)	M	ESCALATORS	L	Hammermill—heavy duty, Hog	H
Calender-super (paper), Calender (rubber)	H	EXTRUDER (metal)	H	PUMPS	
CANE KNIVES (sugar)	M	FANS		Centrifugal, Axial	L
CARD MACHINE (textile)	H	Centrifugal	L	Gear, Lobe, Vane	M
CAR DUMPERS	H	Cooling Tower	H	Reciprocating—sgl. or dbl. acting,	
CAR PULLERS	M	Forced Draft, Large Industrial or Mine	M	cylinder	*
CEMENT KILN	H	FEEDERS		REEL, REWINDER (paper) CABLE	M
CENTRIFUGAL BLOWERS,		Apron, Belt, Disc	L	ROD MILL	H
COMPRESSORS, FANS or PUMPS	L	Reciprocating	H	SAWDUST CONVEYOR	L
CHEMICAL FEEDERS (sewage)	L	Screw	M	SCREENS	
CHILLER (oil)	M	FILTER, PRESS-OIL	M	Air Washing, Water	L
CHIPPER (paper)	H	GENERATORS		Rotary for coal or sand	M
CIRCULAR RESAW (lumber)	M	Uniform load	L	Vibrating	H
CLARIFIER or CLASSIFIER	L	Varying load, Hoist	M	SCREW CONVEYOR	L
CLAY WORKING MACHINERY	M	Welders	H	SLAB CONVEYOR (lumber)	M
COLLECTORS (sewage)	L	GRIT COLLECTOR (sewage)	L	SLITTERS (metal)	M
COMPRESSORS		GRIZZLY	H	SOAPERS (textile)	L
Centrifugal	L	HAMMERMILL		SORTING TABLE (lumber)	M
Reciprocating	*	Light Duty, Intermittent	M	SPINNER (textile)	M
Screw, Lobe	L	Heavy Duty, Continuous	H	STOKER	L
CONCRETE MIXERS	M	HOISTS		SUCTION ROLL (paper)	M
CONVERTING MACHINE (paper)	M	Heavy Duty	H	TENTER FRAMES (textile)	M
CONVEYORS		Medium Duty	M	TIRE BUILDING MACHINES	H
Apron, Assembly Belt, Flight, Oven, Screw	L	JORDAN (paper)	H	TIRE & TUBE PRESS OPENER	L
Bucket	M	KILN, ROTARY	H	TUMBLING BARRELS	H
COOKERS—Brewing, Distilling, Food	L	LAUNDRY WASHER or TUMBLER	H	WASHER and THICKENER (paper)	M
COOLING TOWER FANS	H	LINE SHAFTS	L	WINCHES	M
COUCH (paper)	M	LOG HAUL (lumber)	H	WINDERS, Paper, Textile, Wire	M
CRANES and HOISTS	M	LOOM (textile)	M	WINDLASS	M
Heavy Duty Mine	H	MACHINE TOOLS, MAIN DRIVE	M	WIRE	
CRUSHERS—Cane (sugar), Stone or Ore	H	MANGLE (textile)	L	Drawing	H
CUTTER—Paper	H	MASH TUBS (distilling)	L	Winding	M
CYLINDER (paper)	H	MEAT GRINDER	M	WOODWORKING MACHINERY	L
		METAL FORMING MACHINES	M		

*Consult Factory

2. Determine Service Factor using Load Symbol and driveR.

Load Symbol	L Light	M Medium	H Heavy
Standard AC Motor DC Shunt Motor *Engine, 8 or more cylinders	1.25	1.5	2.0
High Torque AC Motor DC Series & Comp. *Engine, 4-6 cylinders	1.5	2.0	2.5
*Engine, 3 cylinders or less	2.0	2.5	3.0
Turbine	1.0	1.25	1.5

*On applications involving varying torque loads, design around the maximum load. Then determine the resulting service factor at minimum load. If this value is greater than 4.0, special coupling alignment will be required (see page F1—18).

Caution: Applications involving reciprocating engines and reciprocating driven devices are subject to rotational vibrational critical speeds which may destroy the coupling. The factory can determine these speeds when the rotational inertia (WR^2) of the driveR and driveN units is known.

SURE-FLEX COUPLING SIZE SELECTION (continued)



3. If coupling to the shaft of a 60 HZ AC motor, you may refer to page 8, locate the correct chart & columns for your sleeve material, motor speed and service factor; you can read the coupling size across from the motor horsepower.

Example: For 150 HP @ 1750 RPM and 1.5 Service Factor - Use #13 EPDM or Neoprene or #10 Hytrel or Urethane.

4. For other speeds, use the following formula to calculate the required coupling horsepower rating @ 100 rpm.

$$\text{HP @ 100 rpm} = \text{HP} \times \text{Service Factor} \times 100 / \text{coupling RPM}$$

5. Use the chart below to find a coupling with a HP @ 100 RPM rating which is greater than calculated above.

Example: For 5 HP @ 55 RPM and 1.25 Service Factor:

$$\text{HP @ 100} = 5 \times 1.25 \times 100 / 55 = 11.36$$

Use #12 EPDM or Neoprene or #9 Hytrel with rating of 11.4 HP.

COUPLING RATINGS

Size	EPDM Sleeves	Neoprene Sleeves	HP @ RPM				Torque (in. lbs.)	Stiffness (in. lbs./rad)	Max RPM
			100	1160	1750	3500			
3	JE,JES	JN,JNS	0.1	1.1	1.7	3.3	60	229	9200
4	E,JE,JES	N,JN,JNS	0.2	2.2	3.3	6.7	120	458	7600
5	E,JE,JES	N,JN,JNS	0.4	4.4	6.7	13	240	916	7600
6	E,JE,JES	N,JN,JNS	0.7	8.3	12.5	25	450	1718	6000
7	E,JE,JES	N,JN,JNS	1.2	13	20	40	725	2769	5250
8	E,JE,JES	N,JN,JNS	1.8	20	32	63	1135	4335	4500
9	E,JE,JES	N	2.9	33	50	100	1800	6875	3750
10	E,JE,JES	N	4.6	53	80	160	2875	10980	3600
11	E	N	7.2	83	126	252	4530	17300	3600
12	E	N	11.4	132	200		7200	27500	2800
13	E	N	18.0	209	315		11350	43350	2400
14	E	N	28.6	331	500		18000	68755	2200
16	E		75.0	870			47250	180480	1500
Size	Hytrel Sleeves	Urethane Sleeves	HP @ RPM				Torque (in. lbs.)	Stiffness (in. lbs./rad)	Max RPM
			100	1160	1750	3500			
6	H, HS		2.9	33	50	100	1800	10000	6000
7	H, HS		4.6	53	80	160	2875	20000	5250
8	H, HS		7.2	84	126	252	4530	30000	4500
9	H, HS		11.4	132	200	400	7200	47500	3750
10	H, HS	U	18.0	209	315	630	11350	100000*	3600
11	H, HS	U	28.6	331	500	1000	18000	125000*	3600
12	H, HS	U	50.0	580	875		31500	225000*	2800
13	HS		75.0	870	1312		47268	368900	2400
14	HS		115.0	1334	2013		72480	593250	2200

* Urethane values are 220000, 350000, and 600000.



SURE-FLEX COUPLING SELECTION

EPDM or NEOPRENE SLEEVES

860 RPM MOTORS						1160 RPM MOTORS						1750 RPM MOTORS						3500 RPM MOTORS					
HP	Service Factors					HP	Service Factors					HP	Service Factors					HP	Service Factors				
	1.0	1.25	1.5	2.0	2.5		1.0	1.25	1.5	2.0	2.5		1.0	1.25	1.5	2.0	2.5		1.0	1.25	1.5	2.0	2.5
1/2	3	3	3	4	4	1/2	3	3	3	3	4	1/2	3	3	3	3	3	1/2
3/4	3	4	4	4	5	3/4	3	3	4	4	4	3/4	3	3	3	3	4	3/4	3	3	3	3	3
1	4	4	4	5	5	1	3	4	4	4	5	1	3	3	3	4	4	1	3	3	3	3	3
1 1/2	4	5	5	5	6	1 1/2	4	4	5	5	5	1 1/2	3	4	4	4	5	1 1/2	3	3	3	3	4
2	5	5	5	6	6	2	4	5	5	5	6	2	4	4	4	5	5	2	3	3	3	4	4
3	5	6	6	6	7	3	5	5	6	6	6	3	4	5	5	5	6	3	3	4	4	4	5
5	6	6	7	7	8	5	6	6	6	7	7	5	5	5	6	6	6	5	4	4	5	5	5
7 1/2	7	7	8	8	9	7 1/2	6	7	7	8	8	7 1/2	6	6	6	7	7	7 1/2	5	5	5	6	6
10	7	8	8	9	9	10	7	7	8	8	9	10	6	6	7	7	8	10	5	5	6	6	6
15	8	9	9	10	10	15	8	8	9	9	10	15	7	7	8	8	9	15	6	6	6	7	7
20	9	9	10	10	11	20	8	9	9	10	10	20	7	8	8	9	9	20	6	6	7	7	8
25	9	10	10	11	11	25	9	9	10	10	11	25	8	8	9	9	10	25	6	7	7	8	8
30	10	10	11	11	12	30	9	10	10	11	11	30	8	9	9	10	10	30	7	7	8	8	9
40	10	11	11	12	12	40	10	10	11	11	12	40	9	9	10	10	11	40	7	8	8	9	9
50	11	11	12	12	13	50	10	11	11	12	12	50	9	10	10	11	11	50	8	8	9	9	10
60	11	12	12	13	13	60	11	11	12	12	13	60	10	10	11	11	12	60	8	9	9	10	10
75	12	12	13	13	14	75	11	12	12	13	13	75	10	11	11	12	12	75	9	9	10	10	11
100	12	13	13	14	14	100	12	12	13	13	14	100	11	11	12	12	13	100	9	10	10	11	11
125	13	13	14	14	...	125	12	13	13	14	14	125	11	12	12	13	13	125	10	10	11	11	...
150	13	14	14	16	16	150	13	13	14	14	16	150	12	12	13	13	14	150	10	11	11
200	14	14	16	16	16	200	13	14	14	16	16	200	12	13	13	14	14	200	11	11
250	14	16	16	16	16	250	14	14	16	16	16	250	13	13	14	14	...	250	11
300	16	16	16	16	...	300	14	16	16	16	16	300	13	14	14	300
350	16	16	16	350	16	16	16	16	16	350	14	14	350
400	16	16	16	400	16	16	16	16	...	400	14	14	400
450	16	16	450	16	16	450	14	450
500	16	16	500	16	16	500	14	500
600	16	600	16	600	600
700	700	700	700
800	800	800	800

HYTREL or URETHANE SLEEVES

860 RPM MOTORS						1160 RPM MOTORS						1750 RPM MOTORS						3500 RPM MOTORS					
HP	Service Factors					HP	Service Factors					HP	Service Factors					HP	Service Factors				
	1.0	1.25	1.5	2.0	2.5		1.0	1.25	1.5	2.0	2.5		1.0	1.25	1.5	2.0	2.5		1.0	1.25	1.5	2.0	2.5
7 1/2	6	6	6	6	6	7 1/2	7 1/2	7 1/2
10	6	6	6	6	6	10	6	6	6	6	6	10	10
15	6	6	6	7	7	15	6	6	6	6	7	15	6	6	6	6	6	15
20	6	6	7	7	8	20	6	6	6	7	7	20	6	6	6	6	6	20
25	6	7	7	8	8	25	6	6	7	7	8	25	6	6	6	6	7	25
30	7	7	8	8	9	30	6	7	7	8	8	30	6	6	6	7	7	30	6	6	6	6	6
40	7	8	8	9	9	40	7	7	8	8	9	40	6	6	7	7	8	40	6	6	6	6	6
50	8	8	9	9	10	50	7	8	8	9	9	50	6	7	7	8	8	50	6	6	6	6	7
60	8	9	9	10	10	60	8	8	9	9	10	60	7	7	8	8	9	60	6	6	6	7	7
75	9	9	10	10	11	75	8	9	9	10	10	75	7	8	8	9	9	75	6	6	7	7	8
100	9	10	10	11	11	100	9	9	10	10	11	100	8	8	9	9	10	100	6	7	7	8	8
125	10	10	11	11	12	125	9	10	10	11	11	125	8	9	9	10	10	125	7	7	8	8	9
150	10	11	11	12	12	150	10	10	11	11	12	150	9	9	10	10	11	150	7	8	8	9	9
200	11	11	12	12	13	200	10	11	11	12	12	200	9	10	10	11	11	200	8	8	9	9	10
250	11	12	12	13	13	250	11	11	12	12	13	250	10	10	11	11	12	250	8	9	9	10	10
300	12	12	13	13	14	300	11	12	12	13	13	300	10	11	11	12	12	300	9	9	10	10	11
350	12	12	13	14	14	350	12	12	12	13	14	350	11	11	12	12	12	350	9	10	10	11	11
400	12	13	13	14	14	400	12	12	13	13	14	400	11	11	12	12	13	400	9	10	10	11	11
500	13	13	14	14	...	500	12	13	13	14	14	500	11	12	12	13	13	500	10	10	11	11	...
600	13	14	14	600	13	13	13	14	...	600	12	12	13	13	14	600	10	11	11
700	14	14	700	13	13	14	14	...	700	12	12	13	14	14	700	11	11
800	14	14	800	13	14	14	800	12	13	13	14	14	800	11	11
900	14	900	14	14	14	900	13	13	14	14	...	900	11
1000	1000	14	14	1000	13	13	14	14	...	1000	11

TYPE J SURE-FLEX BTS – FOR CLOSE COUPLED APPLICATIONS

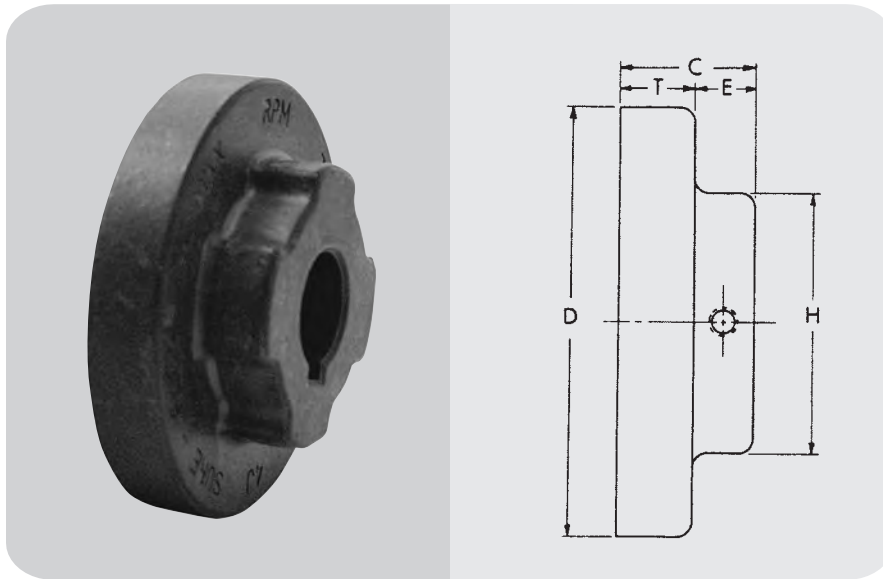

FLANGES

Type J flanges size 3 and 4 are manufactured of sintered carbon steel. The powdered metal manufacturing process provides high dimensional accuracy and uniform material properties for high strength. Size 5 and 6 are made of high strength cast iron. All flanges are bored-to-size for a slip fit on standard shafts. The outside diameter of the flange is machined so the surface can be used to check alignment without a special tool. Type J flanges can be used with sleeves of any construction except the Hytrel. Each flange has a keyseat and one (1) setscrew over the keyway.

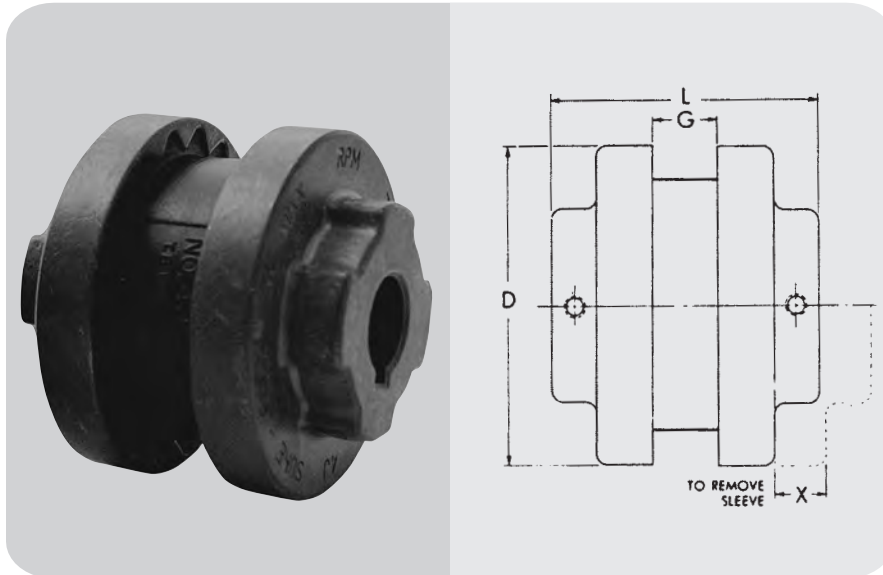

COUPLINGS

Type J Sure-Flex Couplings are bored-to-size. Normally, they employ the one-piece JE sleeve, or the one-piece JES sleeve with saw cut to permit replacement where there is insufficient gap between shafts.

Spacing between internal flange hubs equals G. Spacing between shafts should be greater than 1/8 in. and less than L minus .85 times the sum of the two bore diameters.

To order complete couplings, specify coupling size with flange symbol (J) giving bore and keyseat. Refer to page F1-3 to order the required coupling.

DIMENSIONS (in.)

Product No.	Dimensions								Wt. (lbs.)	STOCK BORES*																					
										(Inches)										Millimeters											
	C	D	E	G	H	L	T	X		3/8	1/2	5/8	3/4	7/8	15/16	1	1-1/8	1-3/16	1-1/4	1-3/8	Max Bore	9	11	12	14	15	16	19	20	24	25
3J	51/64	2.062	13/32	3/8	1-1/2	1-31/32	25/64	5/8	0.3	X	X	X	X	X							7/8	...	X	X	X	X	X	X			
4J	55/64	2.500	27/64	5/8	1-5/8	2-11/32	7/16	5/8	0.4		X	X	X	X	X	X					1	X	X	X	X	X	X	X
5J	1-3/64	3.250	29/64	3/4	1-7/8	2-27/32	19/32	59/64	0.9		X	X	X	X	X	X					1-1/8
6J	1-5/16	4.000	9/16	7/8	2-1/2	3-1/2	3/4	1-3/32	1.2			X	X	X	X	X	X	X	X		1-3/8

*We do not recommend reboring the 3J and 4J Flanges. See page F1-13 for standard keyseat dimensions & F1-10 for bore tolerances.

■ Approximate weight for each flange.

TYPE S SURE-FLEX BTS – FOR CLOSE COUPLED APPLICATIONS

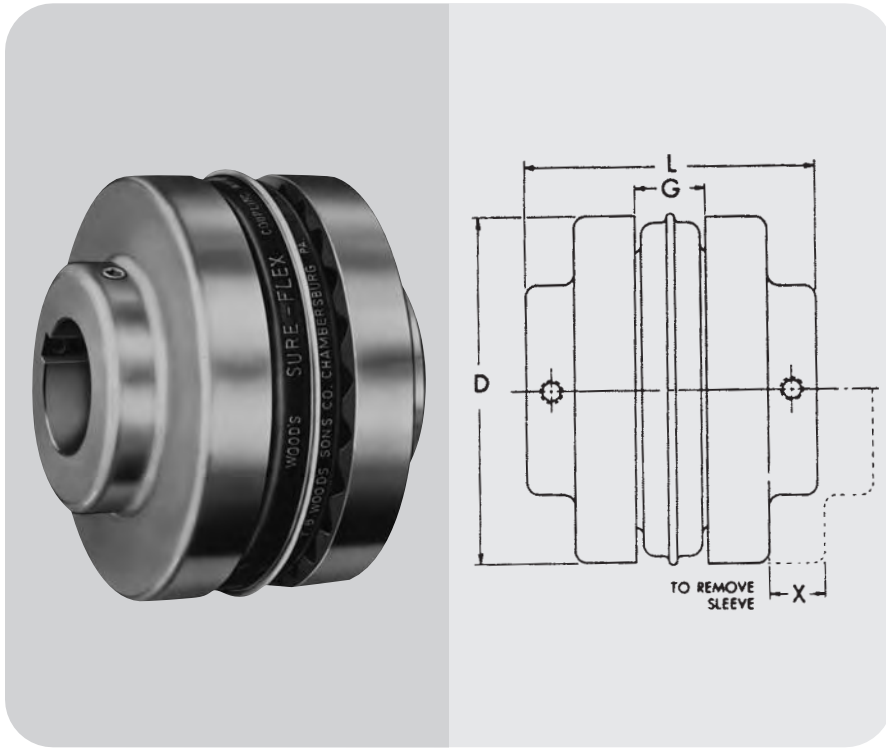

COUPLINGS

Type S Sure-Flex couplings are normally supplied with the two-piece E sleeve. However, any of the sleeves shown on page F1—5 can be used with Type S flanges.

Spacing between internal flange hubs equals L minus 2 times C. Spacing between shafts should be greater than 1/8 in. and less than L minus .85 times the sum of the two bore diameters.

To order complete couplings, specify coupling size with flange symbol (S) giving bore and keyseat. Refer to page F1—3 to order the required coupling.

DIMENSIONS (in.)

STOCK BORES																					Max. Bore		SHALLOW KEYSEAT DIMENSIONS ②										
Millimeters																					①	②	Bore			K.S.			Key				
14	15	16	19	20	24	25	28	30	32	35	38	42	45	48	50	52	55	60	65	70	80	90	Standard Keyseat	Shallow Keyseat	Bore	K.S.	Key	Bore	K.S.	Key	Bore	K.S.	Key
X	X	X	X	X	X	X	X															1-3/16	1-1/4	1-1/4	1/4 X 3/16	1/4 X 3/16 X 1-3/8	1/4 X 3/16 X 1-3/8
	X		X	X	X	X	X	X	X	X	X											1-7/16	1-1/2
																						...	1-3/4	1-1/2 & 1-5/8	3/8 X 1/8	3/8 x 5/16 X ▲	1-3/4	3/8 X 1/16	3/8 X 1/4 X 1-1/4	
																						...	1-7/8	1-7/8	1/2 X 1/16	1/2 X 5/16 X 1-9/16	
		X		X	X	X	X	X	X	X												1-5/8	1-7/8	1-7/8	1/2 X 1/8	1/2 X 3/8 X 1-7/8	
				X		X	X	X	X	X	X											1-15/16	2-1/4	2-1/8	1/2 X 3/16	1/2 X 7/16 X 2-1/8	
																						...	2-3/8	2-3/8	5/8 X 1/8	5/8 X 7/16 X 1-7/8	
				X		X	X	X	X	X												2-1/2	2-3/4	
																						...	2-7/8	2-7/8	3/4 X 1/8	3/4 X 1/2 X 2-1/4	
							X	X	X	X	X	X	X	X	X							2-3/4	3-1/8	2-7/8	3/4 X 1/4	3/4 X 5/8 X 2-3/4	
																						...	3-3/8	3-3/8	7/8 X 3/16	7/8 X 5/8 X 2-5/8	
							X	X	X	X	X	X	X	X			X	X	X	X		3-3/8	3-7/16	3-7/16	7/8 X 3/16	7/8 X 5/8 X 3-7/16	
																						...	3-7/8	3-7/8	1 X 1/4	1 X 3/4 X 3	
															X		X	X	X	X		3-7/8	3-15/16	
																						4-1/2	
																						5	
																						5-1/2	6	

① See charts on page F1—13
 ② Some large bore Type S flanges are supplied with shallow keyseats. In these cases, a rectangular key is furnished. The bores involved are listed above.
 ▲ 1-5/8 for 1-1/2 bore, 1-5/16 for 1-5/8 bore.

TYPE B BUSHED-FLEX

QD – FOR CLOSE COUPLED APPLICATIONS

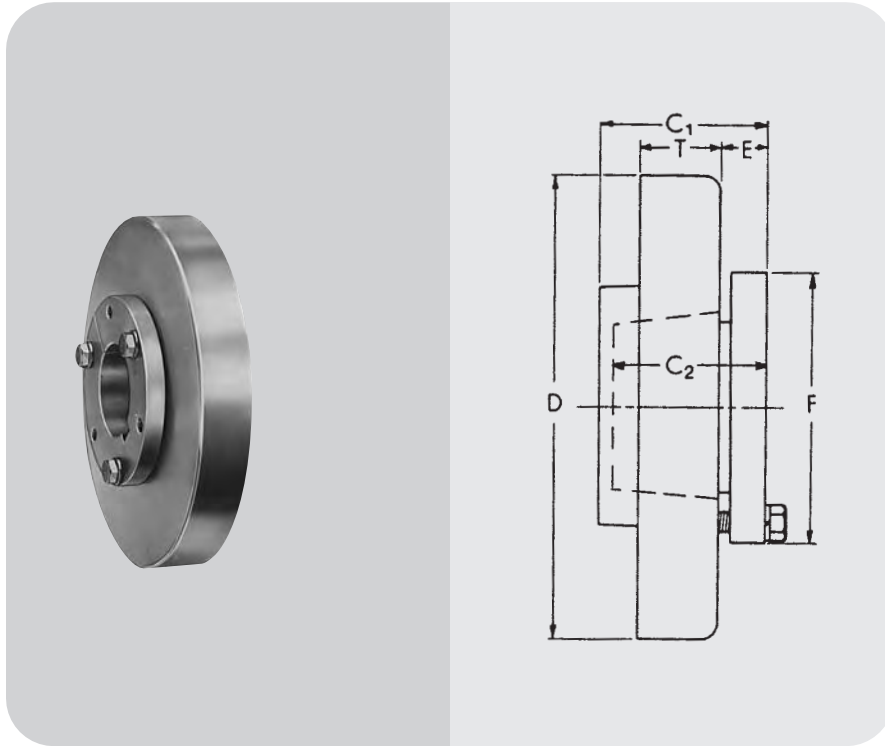

FLANGES

Type B flanges are made of high-strength cast iron the same as Types S, C and SC Sure-Flex flanges. Type B, however, is designed to accommodate Wood's Sure-Grip Bushing for easy installation and removal.

BUSHINGS

Sure-Grip Bushings offer convenient mounting of the flange to the shaft securely without setscrews. They are tapered and are split through both the bushing flange and taper to provide a clamp fit, eliminating wobble, vibration and fretting corrosion. This is the same bushing used in Wood's sheaves and pulleys and is readily available everywhere.

DIMENSIONS (in.)

Product No.	Bushing Required	Dimensions									Max. * Bore	Flange	Weight (lbs.) ■ Bushing
		C ₁	C ₂	D	E	F	G	L	T	X			
6B	JA	1 7/32	1	4.000	15/32	2	7/8	3 3/8	25/32	1 3/32	1 1/4	1.4	.8
7B	JA	1 5/8	1	4.625	15/32	2	1	3 1/2	25/32	1 5/16	1 1/4	1.9	.8
8B	SH	1 29/32	1 1/4	5.450	9/16	2 11/16	1 1/8	4 1/16	29/32	1 1/2	1 5/8	2.9	1.0
9B	SD	2 1/4	1 13/16	6.350	5/8	3 3/16	1 7/16	4 3/4	1 1/32	1 3/4	1 15/16	4.8	1.5
10B	SK	1 15/16	1 7/8	7.500	23/32	3 7/8	1 5/8	5 1/2	1 7/32	2	2 1/2	7.8	2.0
11B	SF	2 3/16	2	8.625	11/16	4 5/8	1 7/8	6 1/4	1 1/2	2 3/8	2 15/16	12.0	3.5
12B	E	2 23/32	2 5/8	10.000	29/32	6	2 5/16	7 1/2	1 11/16	2 11/16	3 1/2	18.0	9.0
13B	F	3 3/4	3 5/8	11.750	1 1/16	6 5/8	2 11/16	8 3/4	1 31/32	3	3 15/16	31.2	14.0
14B	F	3 3/4	3 5/8	13.875	1 1/16	6 5/8	3 1/4	9 7/8	2 1/4	3 1/2	3 15/16	51.4	14.0
16B	J	4 13/16	4 1/2	18.875	1 1/4	7 1/4	4 3/4	12 3/4	2 3/4	4 1/4	4 1/2	120.0	22.0

*Maximum bore with keyseat. ■ Approximate weight for each flange.

TYPE B BUSHED-FLEX QD – FOR CLOSE COUPLED APPLICATIONS

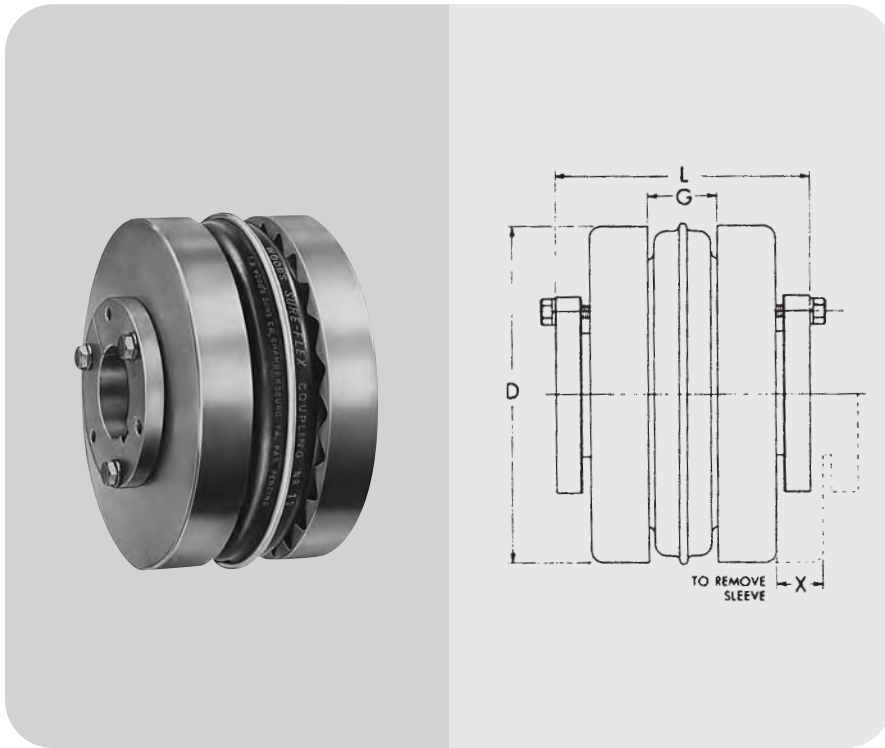

COUPLINGS

Type B Sure-Flex Couplings are normally supplied with the two-piece E sleeve, and can use any EPDM or Neoprene sleeves. DO NOT use Hytrel sleeves with Type B couplings.

Spacing between internal flange hubs equals L minus 2 times C. Spacing between shafts should be greater than 1/8 in. and less than G.

To order complete couplings, specify coupling size with flange symbol (B) and bushing. Refer to page F1–3 to order the required coupling. Refer to charts below for bushings.

SURE-GRIP® BUSHING KEYSEAT DIMENSIONS (in.)

Bushing	Bores	Keyseat
JA	1/2 – 1	Standard ②
	1 1/16 – 1 3/16	1/4 X 1/16
	1 1/4	1/4 X 1/32
SH	1/2 – 1 3/8	Standard ②
	1 7/16 – 1 5/8	3/8 X 1/16
	1 11/16	No K.S.
SD	1/2 – 1 11/16	Standard ②
	1 3/4	3/8 X 1/8
	1 13/16	1/2 X 1/8
	1 7/8 – 1 15/16	1/2 X 1/16
SK	1/2 – 2 1/8	Standard ②
	2 3/16 – 2 1/4	1/2 X 1/8
	2 5/16 – 2 1/2	5/8 X 1/16
	2 9/16 – 2 5/8	No K.S.

Bushing	Bores	Keyseat
SF	1/2 – 2 1/4	Standard ②
	2 5/16 – 2 1/2	5/8 X 3/16
	2 9/16 – 2 3/4	5/8 X 1/16
	2 13/16 – 2 7/8	3/4 X 1/16
	2 15/16	3/4 X 1/32
E	7/8 – 2 7/8	Standard ②
	2 15/16 – 3 1/4	3/4 X 1/8
	3 5/16 – 3 1/2	7/8 X 1/16
F	1 – 3 1/4	Standard ②
	3 5/16 – 3 3/4	7/8 X 3/16
	3 13/16 – 3 15/16	1 X 1/8
	4	No K.S.
J	1 7/16 – 3 13/16	Standard ②
	3 7/8 – 3 15/16	1 X 3/8
	4 – 4 1/2	1 X 1/8

②

Standard Keyseat Dimension

Shaft Dia.	Width	Depth
1/2 – 9/16	1/8	1/16
5/8 – 7/8	3/16	3/32
15/16 – 1 1/4	1/4	1/8
1 5/16 – 1 3/8	5/16	5/32
1 7/16 – 1 3/4	3/8	3/16
1 13/16 – 2 1/4	1/2	1/4
2 5/16 – 2 3/4	5/8	5/16
2 13/16 – 3 1/4	3/4	3/8
3 5/16 – 3 3/4	7/8	7/16
3 13/16 – 4 1/2	1	1/2
4 9/16 – 5 1/2	1 1/4	5/8
5 9/16 – 6 1/2	1 1/2	3/4

TYPE SC SPACER COUPLINGS

BTS - CONVENTIONAL SPACER DESIGN

BTS - CONVENTIONAL SPACER DESIGN

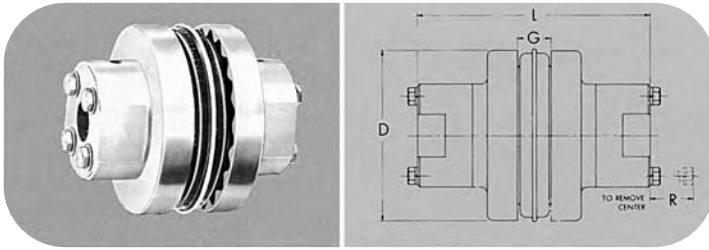

The table below shows assembled dimensions of Sure-Flex Type SC Spacer Couplings. For dimensions of separate components, refer to page F1—15.

Coupling Size	Required Distance Between Shafts	Use Flange No.	Use Hub No.	Max. Bore Std. KS	Dimensions				Wt. (lbs.) ■
					D	L(2)	G	R	
4JSC	3-1/2	4JSC35	1-1/8 ⁽¹⁾	2.460	5-5/8	5/8	2.7
5SC	3-1/2	5SC35	5SCH	1-1/8	3.250	5-5/8	3/4	9/16	4.5
6SC	3-1/2	6SC35	6SCH-6SCHS	1-3/8	4.000	5-7/8	7/8	3/4	7.3
	4-3/8	6SC44	6SCH-6SCHS	1-3/8	4.000	6-3/4	7/8	3/4	8.1
	5	6SC50	6SCH-6SCHS	1-3/8	4.000	7-3/8	7/8	3/4	8.7
7SC	3-1/2	7SC35	7SCH-7SCHS	1-5/8	4.625	6-3/8	1	5/8	9.9
	4-3/8	7SC44	7SCH-7SCHS	1-5/8	4.625	7-1/4	1	5/8	10.8
	5	7SC50	7SCH-7SCHS	1-5/8	4.625	7-7/8	1	5/8	11.4
8SC	3-1/2	8SC35	8SCH-8SCHS	1-7/8	5.450	6-7/8	1-1/8	13/16	15.2
		8SC35-10	10SCH-10SCHS	2-3/8	5.450	8-1/8	1-1/8	13/16	23.2
	4-3/8	8SC44	8SCH-8SCHS	1-7/8	5.450	7-3/4	1-1/8	13/16	16.4
	5	8SC50	8SCH-8SCHS	1-7/8	5.450	8-3/8	1-1/8	1-3/16	17.4
		8SC50-10	10SCH-10SCHS	2-3/8	5.450	9-5/8	1-1/8	1-3/16	27.2
9SC	3-1/2	9SC35	9SCH-9SCHS	2-1/8	6.350	7-1/2	1-7/16	1-1/16	18.6
	4-3/8	9SC44	9SCH-9SCHS	2-1/8	6.350	8-1/4	1-7/16	1-1/16	22.2
	5	9SC50	9SCH-9SCHS	2-1/8	6.350	8-7/8	1-7/16	1-1/16	23.2
		9SC50-11	11SCH-11SCHS	2-7/8	6.350	10-3/8	1-7/16	1-3/16	40.4
	7	9SC70-11	11SCH-11SCHS	2-7/8	6.350	12-3/8	1-7/16	1-3/16	48.2
10SC	7-3/4	9SC78-11	11SCH-11SCHS	2-7/8	6.350	13-1/8	1-7/16	1-3/16	51.0
	4-3/4	10SC48	10SCH-10SCHS	2-3/8	7.500	9-3/8	1-5/8	1-3/16	37.6
	5	10SC50	10SCH-10SCHS	2-3/8	7.500	9-5/8	1-5/8	1-3/16	38.4
	7	10SC70-13	13SCH-13SCHS	3-3/8	7.500	13-5/8	1-5/8	1-7/8	72.0
	7-3/4	10SC78-13	13SCH-13SCHS	3-3/8	7.500	14-3/8	1-5/8	1-7/8	76.0
11SC	10	10SC100-13	13SCH-13SCHS	3-3/8	7.500	16-5/8	1-5/8	1-7/8	88.0
	4-3/4	11SC48	11SCH-11SCHS	2-7/8	8.625	10-5/16	1-7/8	1-3/16	54.5
	5	11SC50	11SCH-11SCHS	2-7/8	8.625	10-3/8	1-7/8	1-3/16	54.7
	7	11SC70-14	14SCH	3-7/8	8.625	14-5/8	1-7/8	2	86.1
	7-3/4	11SC78-14	14SCH	3-7/8	8.625	15-3/8	1-7/8	2	90.3
12SC	10	11SC100-14	14SCH	3-7/8	8.625	17-5/8	1-7/8	2	102.7
	7	12SC70	12SCH-12SCHS	2-7/8	10.000	12-7/8	2-5/16	1-1/2	88.1
		12SC70-14	14SCH	3-7/8	10.000	14-5/8	2-5/16	2	99.1
	7-3/4	12SC78	12SCH-12SCHS	2-7/8	10.000	13-5/8	2-5/16	1-1/2	91.9
		12SC78-14	14SCH	3-7/8	10.000	15-3/8	2-5/16	2	103.3
13SC	10	12SC100-14	14SCH	3-7/8	10.000	17-5/8	2-5/16	2	115.7
	7-3/4	13SC78	13SCH-13SCHS	3-3/8	11.750	14-3/8	2-11/16	1-7/8	129.6
14SC	7-3/4	14SC78	14SCH	3-7/8	13.875	15-3/8	3-1/4	2	179.9

■ Approximate weight for completely assembled spacer coupling.

(1) 4JSC35 x 1-1/8 has shallow keyseat. (2) "L" dimension and weight will change if one or two short (HS) hubs used.

Note: Refer to page F1—15 to order — specify components separately.

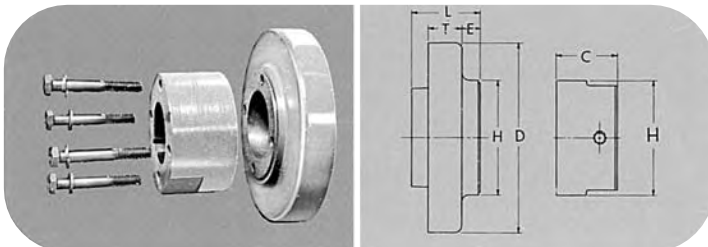

TYPE SC FLANGES AND HUBS

Tables on page F1—15 provide dimensional information for flanges and hubs used for Spacer Couplings. For assembled dimensions, see table above. Any of the sleeves shown on page F1—5 may be used.

TYPE SC FLANGES AND HUBS

BTS - CONVENTIONAL SPACER DESIGN



(ILLUSTRATION AND DIMENSIONAL DRAWINGS SHOWN AT BOTTOM OF PAGE F1—14.)

Coupling Size	Flange No.	For Distance Between Shafts*	For Hub	Dimensions					Wt. (lbs.) ■
				D	E	H	L	T	
4JSC	4JSC35	3-1/8	...	2.460	2-1/16	2	2-1/2	7/16	1.3
5SC	5SC35	3-1/2	5SCH	3.250	51/64	2	1-11/16	19/32	1.3
6SC	6SC35	3-1/2	6SCH-6SCHS	4.000	19/32	2-1/2	1-5/8	23/32	2.0
	6SC44	4-3/8	6SCH-6SCHS	4.000	1-1/32	2-1/2	2-1/16	23/32	2.4
	6SC50	5	6SCH-6SCHS	4.000	1-11/32	2-1/2	2-3/8	23/32	2.7
7SC	7SC35	3-1/2	7SCH-7SCHS	4.625	15/32	2-13/16	1-5/8	25/32	2.5
	7SC44	4-3/8	7SCH-7SCHS	4.625	29/32	2-13/16	2-1/16	25/32	3.0
	7SC50	5	7SCH-7SCHS	4.625	1-7/32	2-13/16	2-3/8	25/32	3.3
8SC	8SC35	3-1/2	8SCH-8SCHS	5.450	9/32	3-1/4	1-5/8	29/32	3.7
	8SC35-10	3-1/2	10SCH-10SCHS	5.450	9/32	4-3/8	1-5/8	29/32	3.5
	8SC44	4-3/8	8SCH-8SCHS	5.450	23/32	3-1/4	2-1/16	29/32	4.3
	8SC50	5	8SCH-8SCHS	5.450	1-1/32	3-1/4	2-3/8	29/32	4.8
9SC	8SC50-10	5	10SCH-10SCHS	5.450	1-1/32	4-3/8	2-3/8	29/32	5.5
	9SC35	3-1/2	9SCH-9SCHS	6.350	1/16	3-5/8	1-11/16	1-1/32	4.1
	9SC44	4-3/8	9SCH-9SCHS	6.350	7/16	3-5/8	2-1/16	1-1/32	5.9
	9SC50	5	9SCH-9SCHS	6.350	3/4	3-5/8	2-3/8	1-1/32	6.4
10SC	9SC50-11	5	11SCH-11SCHS	6.350	3/4	5-1/4	2-3/8	1-1/32	7.0
	9SC70-11	7	11SCH-11SCHS	6.350	1-3/4	5-1/4	3-3/8	1-1/32	10.9
	9SC78-11	7-3/4	11SCH-11SCHS	6.350	2-1/8	5-1/4	3-3/4	1-1/32	12.3
	10SC48	4-3/4	10SCH-10SCHS	7.500	11/32	4-3/8	2-1/4	1-7/32	9.8
11SC	10SC50	5	10SCH-10SCHS	7.500	15/32	4-3/8	2-3/8	1-7/32	10.2
	10SC70-13	7	13SCH-13SCHS	7.500	1-15/32	6-1/8	3-3/8	1-7/32	14.5
	10SC78-13	7-3/4	13SCH-13SCHS	7.500	1-27/32	6-1/8	3-3/4	1-7/32	16.5
	10SC100-13	10	13SCH-13SCHS	7.500	2-31/32	6-1/8	4-7/8	1-7/32	22.5
12SC	11SC48	4-3/4	11SCH-11SCHS	8.625	1/32	5-1/4	1-1/2	1-1/2	12.5
	11SC50	5	11SCH-11SCHS	8.625	1/16	5-1/4	1-9/16	1-1/2	12.6
	11SC70-14	7	14SCH	8.625	1-1/16	6-1/2	2-9/16	1-1/2	16.3
	11SC78-14	7-3/4	14SCH	8.625	1-7/16	6-1/2	2-15/16	1-1/2	18.4
13SC	11SC100-14	10	14SCH	8.625	2-9/16	6-1/2	4-1/16	1-1/2	24.6
	12SC70	7	12SCH-12SCHS	10.000	21/32	5-3/4	2-15/32	1-11/16	23.4
	12SC70-14	7	14SCH	10.000	21/32	6-1/2	2-15/32	1-11/16	21.3
	12SC78	7-3/4	12SCH-12SCHS	10.000	1-1/32	5-3/4	2-27/32	1-11/16	25.3
14SC	12SC78-14	7-3/4	14SCH	10.000	1-1/32	6-1/2	2-27/32	1-11/16	23.4
	12SC100-14	10	14SCH	10.000	2-5/32	6-1/2	3-31/32	1-11/16	29.6
13SC	13SC78	7-3/4	13SCH-13SCHS	11.750	9/16	6-1/8	3-1/4	1-31/32	38.4
14SC	14SC78	7-3/4	14SCH	13.875	1/32	6-1/2	2-23/32	2-1/4	55.2

* Flanges can be mixed to form different Between-Shaft Dimensions. See chart page F1—16. ■ Approximate weight for each flange.
 ▲ If using 10HS hub, 7/16-14NC x 2-1/4 long capscrew needed (not furnished).

Coupling Size	Hub No.	Max. Bore	STOCK BORES *		Dimensions			Wt. (lbs.) ■
			Plain Bore	Bore with Standard Keyway & Set Screw	C	H	Cap Screws Furnished	
4JSC	†	1-1/8	...	5/8 - 7/8 - 1 - 1-1/8*	1-1/16	2
5SC	5SCH	1-1/8	1/2	5/8 - 3/4 - 7/8 - 1 - 1-1/8	1-3/32	2	4-10 x 1-1/2	.8
6SC	6SCH	1-3/8	5/8	3/4 - 7/8 - 1 - 1-1/8 - 1-1/4 - 1-3/8	1-7/32	2-1/2	4-1/4 x 1-3/4	1.4
	6SCHS	7/8	...	7/8	31/32	2-1/2	4-1/4 x 1-1/2	1.1
7SC	7SCH	1-5/8	5/8	7/8 - 1 - 1-1/8 - 1-3/8 - 1-1/2 - 1-5/8	1-15/32	2-13/16	4-1/4 x 1-7/8	2.0
	7SCHS	7/8	...	7/8	1-3/32	2-13/16	4-1/4 x 1-1/2	1.5
8SC	8SCH	1-7/8	3/4	7/8 - 1 - 1-1/8 - 1-3/8 - 1-1/2 - 1-5/8 - 1-3/4 - 1-7/8	1-23/32	3-1/4	4-5/16 x 2-1/4	3.2
	8SCHS	7/8	...	7/8	1-7/32	3-1/4	4-5/16 x 1-3/4	2.0
9SC	9SCH	2-1/8	7/8	1 - 1-1/8 - 1-3/8 - 1-1/2 - 1-5/8 - 1-3/4 - 1-7/8 - 2-1/8	1-31/32	3-5/8	4-3/8 x 2-3/4	4.2
	9SCHS	1-1/2	...	1-1/8	1-17/32	3-5/8	4-3/8 x 2-1/4	3.7
10SC	10SCH	2-3/8	1-1/8	1-5/8 - 1-7/8 - 2-1/8 - 2-3/8	2-11/32	4-3/8	4-7/16 x 3-1/4	7.4
	10SCHS	1-5/8	...	1-1/8	1-21/32	4-3/8	4-7/16 x 2-1/2	5.5
11SC	11SCH	2-7/8	1-1/8	1-7/8 - 2-1/8 - 2-3/8 - 2-7/8	2-23/32	5-1/4	4-1/2 x 3-1/2	12.2
	11SCHS	1-7/8	...	1-1/8 - 1-5/8	1-29/32	5-1/4	4-1/2 x 2-3/4	9.3
12SC	12SCH	2-7/8	1-3/8	2-1/8 - 2-3/8 - 2-7/8	2-31/32	5-3/4	4-5/8 x 4	16.6
	12SCHS	2-1/2	...	2-3/8	2-17/32	5-3/4	4-5/8 x 3-1/2	14.1
13SC	13SCH	3-3/8	1-3/8	2-3/8 - 2-7/8 - 3-3/8	3-11/32	6-1/8	4-5/8 x 4-1/2	19.9
	13SCHS	2-1/2	...	2-1/8 - 2-3/8	2-15/32	6-1/8	4-5/8 x 3-1/2	16.0
14SC	14SCH	3-7/8	1-5/8	2-3/8 - 2-7/8 - 3-3/8 - 3-7/8	3-27/32	6-1/2	4-5/8 x 5	24.2

† FOR 4JSC the hub is an integral part of the flange. 4JSC x 1-1/8 has 1/4 x 1/16 shallow keyseat. ■ Approximate weight for each hub.
 * See page F1—10 for bore tolerances F1—13 for std. keyseat dimensions.

BETWEEN SHAFT SPACINGS AVAILABLE

Spacer couplings are available having the most popular between shaft dimensions. Other spacings can be achieved by mixing flanges.

The "Standard" column provides spacings using identical flanges; the "Combination" column mixes flanges; the column headed "Semi-Spacer" uses one flange that is not made for spacer coupling applications and thus does not have a detachable hub.

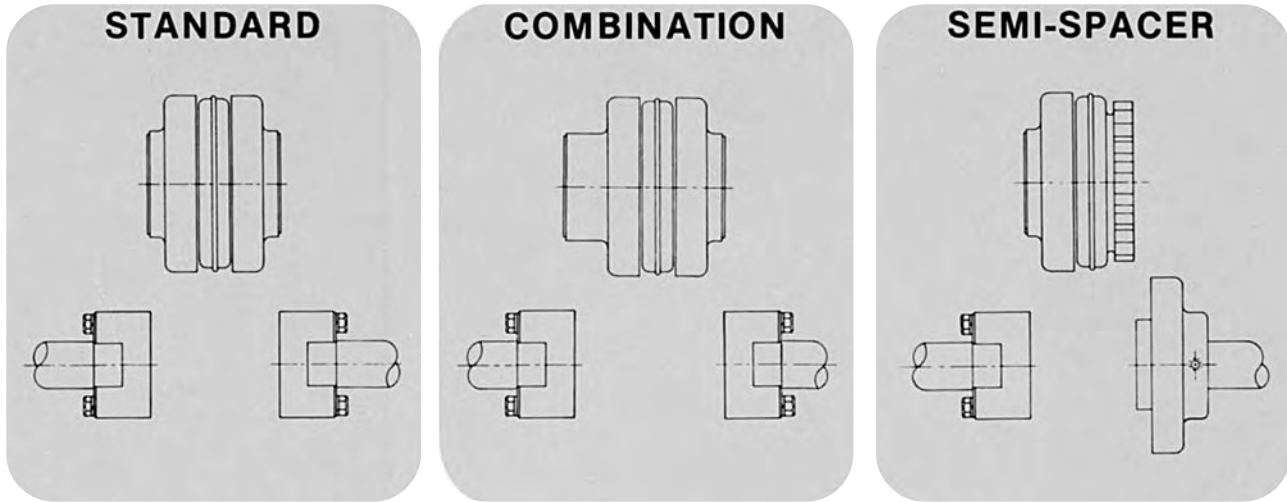

STANDARD		COMBINATION		SEMI-SPACER	
Spacing	Use Flanges*	Spacing	Use Flanges*	Spacing	Use Flanges*
3-1/2	2-() SC35	3-15/16	SC35 & SC44	1-7/8	S & SC35
4-3/8	2-() SC44	4-1/4	SC35 & SC50	2-5/16	S & SC44
5	2-() SC50	4-11/16	SC44 & SC50	2-5/8	S & SC50
7	2-() SC70	5-1/4	SC35 & SC70	3-5/8	S & SC70
7-3/4	2-() SC78	5-5/8	SC35 & SC78	4	S & SC78
10	2-() SC100	5-11/16	SC44 & SC70	5-1/8	S & SC100
		6	SC50 & SC70		
		6-1/16	SC44 & SC78		
		6-3/8	SC50 & SC78		
		6-3/4	SC35 & SC100**		
		7-3/16	SC44 & SC100**		
		7-3/8	SC70 & SC78		
		7-1/2	SC50 & SC100		
		8-1/2	SC70 & SC100		
		8-7/8	SC78 & SC100		

* Check individual coupling size for flange availability.
 ** Non-Stock
 Note: Other combinations available — consult factory.

CLAMP HUB – SPACER DESIGN

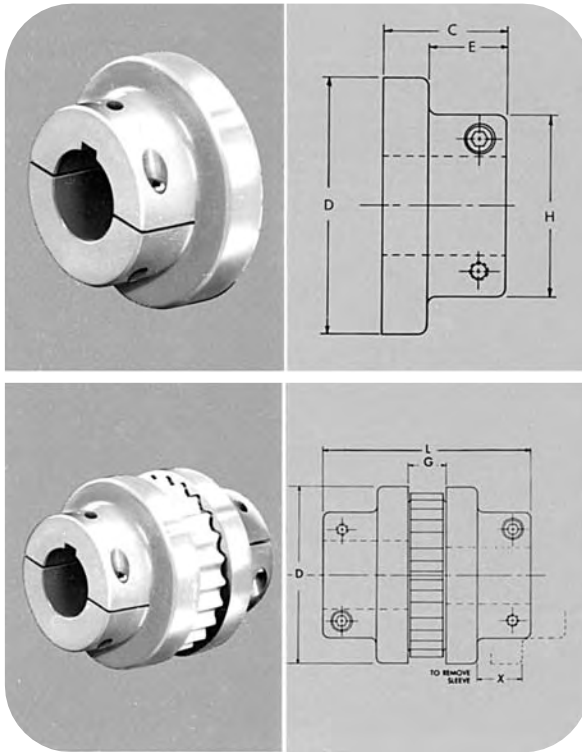

FLANGES

Sure-Flex® Type C Clamp Hub flanges employ integral locking collars and screws to assure a clamp fit on the shaft. One setscrew is furnished over the key. They are designed primarily for applications where flanges must be removed from one or both shafts without moving either the driver or driven units. A typical application is a screw compressor which uses a replaceable face seal around the input shaft.

COUPLINGS

Type C Clamp Hub Couplings normally use Hytrel sleeves. However, any of the sleeves shown on page F1–5 can be used. Type C couplings may often be used where spacer couplings are required.

Spacing between internal flange hubs equals G.

To order complete couplings, specify coupling size with flange symbol (C), giving bore required. Refer to page F1–3 to order the required coupling.

DIMENSIONS (in.)

Flange Size	S k Botes	Min. Bore	Maximum Bore		Distance Between Shafts		Dimensions						Approx. Wt. (lbs.)*	
			Standard Keyseat	Shallow Keyseat	Min.	Max.	C	D	E	G	H	L		X
6C	1-1/8, 1-7/8, 40mm	7/8	1-5/8	1-7/8	2	2-3/4	1-15/16	4.000	1.16	7/8	3	4-3/4	1	2.6
7C	1-3/8, 1-7/8, 35mm, 40mm	1-1/8	1-7/8	–	2-5/16	3-7/16	2-3/16	4.625	1.41	1-1/16	3-1/4	5-7/16	1-3/16	3.6
8C	1-3/8, 1-5/8, 1-3/4, 1-7/8, 2-1/8, 2-1/4, 2-3/8, 40mm	1-3/8	2-1/4	2-3/8	2-9/16	4	2-1/2	5.450	1.59	1-1/8	3-7/8	6-1/8	1-3/8	6.5
9C	1-5/8, 1-3/4, 1-7/8, 2, 2-1/8, 2-1/4, 2-3/8, 2-1/2	1-5/8	2-1/2	2-11/16	3-1/16	4-5/8	3	6.350	1.97	1-7/16	4-1/4	7-7/16	1-9/16	9.8
10C	1-5/8, 1-7/8, 2-1/4, 2-3/8, 2-1/2	1-5/8	2-7/8	–	3-9/16	5-1/4	3-1/2	7.500	2.28	1-11/16	5	8-11/16	1-13/16	16.6
11C	2-1/8, 2-3/8, 2-1/2	1-7/8	3-3/8	–	4-1/8	5-7/8	4	8.625	2.5	1-7/8	5-3/8	9-7/8	2-1/8	26.0
12C	2-1/8	1-7/8	3-3/8	–	4-7/8	6-1/2	4-3/8	10.000	2.69	2-3/8	6	11-1/8	2-3/8	38.3

For Standard keyseat dimensions, see chart page F1–13. * Weight of one flange.

Bore Tolerances for Type C Flanges

These bores provide a slip fit.

Bore (in.)	Tolerance (in.)
Up to and including 2"	+0.0005 to +0.0015
Over 2"	+0.0005 to +0.0020

Shallow Keyseat Dimensions

Some large bore Type C flanges are supplied with shallow keyseats. In these cases, a rectangular key is furnished. The flanges and bores involved are as follows:

Size	Bore Range	KS	Key Furnished
6C	1-11/16 to 1-7/8	1/2 X 1/16	1/2 x 5/16 x 1-15/16
8C	2-5/16 to 2-3/8	5/8 x 1/16	5/8 x 3/8 x 2-1/2
9C	2-7/16 to 2-11/16	5/8 x 3/16	5/8 x 1/2 x 3

Installation Instructions

Sure-Flex flanges (outer metallic parts) and sleeves (inner elastomeric members) come in many sizes and types. First, determine the size and type of components being used. Remove all components from their boxes, and loosely assemble the coupling on any convenient surface. (Do not attempt to install the wire ring on the two-piece E or N sleeve at this time.) Also check maximum RPM values in the table against operating speed. All rubber sleeves (EPDM and Neoprene) have the same ratings for a given size and may be used interchangeably. However, because rubber and Hytrel sleeves have completely different ratings, they never should be used interchangeably.

- 1** Inspect all coupling components and remove any protective coatings or lubricants from bores, mating surfaces and fasteners. Remove any existing burrs, etc. from the shafts.
- 2** Slide one coupling flange onto each shaft, using snug-fitting keys where required. When using Type B flanges, follow the instructions furnished with the Sure-Grip bushing.
- 3** Position the flanges on the shafts to approximately achieve the Y dimension shown in the table. It is usually best to have an equal length of shaft extending into each flange. Move one flange to its final position. Torque fasteners to proper values. Slide the other flange far enough away to install the sleeve. With a two-piece sleeve, do not move the wire ring to its final position; allow it to hang loosely in the groove adjacent to the teeth.

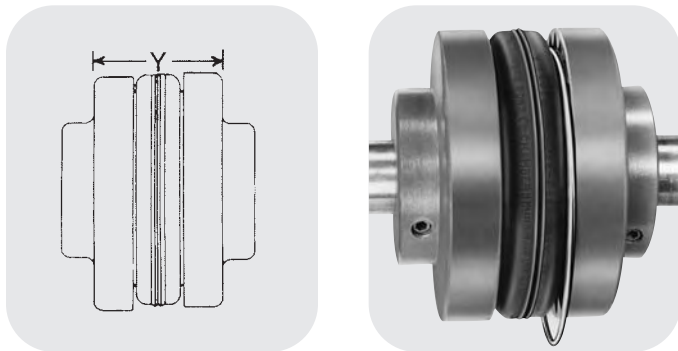

- 4** Slide the loose flange on the shaft until the sleeve is completely seated in the teeth of each flange. (The “Y” dimension is for reference and not critical.) Secure the flange to the shaft. Different coupling sleeves require different degrees of alignment precision. Locate the alignment values for your sleeve size and type in the table.

- 5** Check parallel alignment by placing a straight-edge across the two coupling flanges and measuring the maximum offset at various points around the periphery of the coupling without rotating the coupling. If the maximum offset exceeds the figure shown under “Parallel” in the table, realign the shafts.

- 6** Check angular alignment with a micrometer or caliper. Measure from the outside of one flange to the outside of the other at intervals around the periphery of the coupling. Determine the maximum and minimum dimensions without rotating the coupling. The difference between the maximum and minimum must not exceed the figure given under “Angular” in the table. If a correction is necessary, be sure to recheck the parallel alignment.



Parallel



Angular

MAXIMUM RPM AND ALLOWABLE MISALIGNMENT

(Dimensions in inches)

Sleeve Size	Maximum RPM	Types JE, JN, JES, JNS, E & N			*Type H & HS		
		Parallel	Angular	Y	Parallel	Angular	Y
3	9200	.010	.035	1.188
4	7600	.010	.043	1.500
5	7600	.015	.056	1.938
6	6000	.015	.070	2.375	.010	.016	2.375
7	5250	.020	.081	2.563	.012	.020	2.563
8	4500	.020	.094	2.938	.015	.025	2.938
9	3750	.025	.109	3.500	.017	.028	3.500
10	3600	.025	.128	4.063	.020	.032	4.063
11	3600	.032	.151	4.875	.022	.037	4.875
12	2800	.032	.175	4.688	.025	.042	5.688
13	2400	.040	.195	6.688	.030	.050	6.625
14	2200	.045	.242	7.750	.035	.060	7.750
16	1500	.062	.330	10.250

Note: Values shown above apply if the actual torque transmitted is more than 1/4 the coupling rating. For lesser torque, reduce the above values by 1/2.

*Type H and HS sleeves **should not** be used as direct replacements for EPDM or Neoprene sleeves.

- 7** If the coupling employs the two-piece sleeve with the wire ring, force the ring into its groove in the center of the sleeve. It may be necessary to pry the ring into position with a blunt screwdriver.

- 8** Install coupling guards per OSHA requirements.

CAUTION: Coupling sleeves may be thrown from the coupling assembly with substantial force when the coupling is subjected to a severe shock load or abuse.