

Mounted Bearings

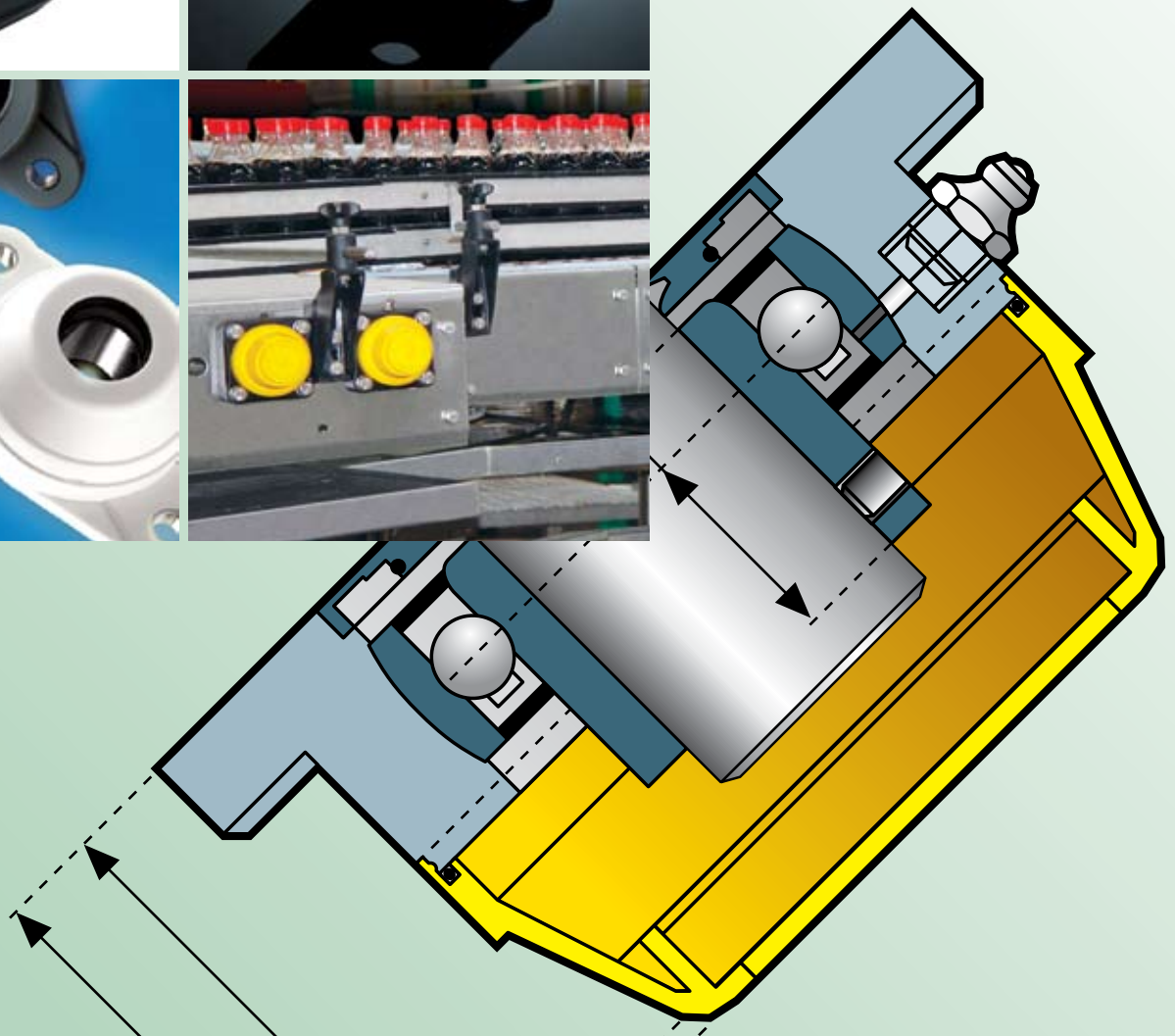

- High Load Polymer Housings
- Antimicrobial
- Stainless Inserts
- Caps and Seals
- Wash Down Applications
- Self Aligning





Long Life Grease • Easy Cleaning • Lo

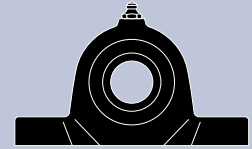
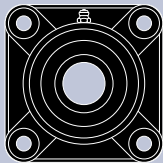

UCFQ

UCFH

UCFA

UCP

- Solid housing
- 4 bolt mounting
- Interchangeable with cast iron version

Inch shaft dia. sizes:

3/4, 1, 1-1/4, 1-7/16, 1-1/2

Millimeter shaft dia. sizes:

20, 25, 30, 35, 40

Housing materials:

- Black polyamide
- White Nolu-Clean antimicrobial polyamide

Bearing materials:

- Chrome steel
- Stainless Steel

- Solid housing
- 2 bolt mounting
- Interchangeable with cast iron version

Inch shaft dia. sizes:

3/4, 1, 1-1/4, 1-7/16, 1-1/2

Millimeter shaft dia. sizes:

20, 25, 30, 35, 40

Housing materials:

- Black polyamide
- White Nolu-Clean antimicrobial polyamide

Bearing materials:

- Chrome steel
- Stainless Steel

- Solid housing
- 3 bolt mounting
- Interchangeable with cast iron version

Inch shaft dia. sizes:

3/4, 1, 1-1/4

Millimeter shaft dia. sizes:

20, 25, 30

Housing materials:

- Black polyamide
- White Nolu-Clean antimicrobial polyamide

Bearing materials:

- Chrome steel
- Stainless Steel

- Pillow block design
- 2 bolt mounting
- Interchangeable with cast iron version

Inch shaft dia. sizes:

3/4, 1, 1-1/4, 1-7/16, 1-1/2

Millimeter shaft dia. sizes:

20, 25, 30, 35, 40

Housing materials:

- Black polyamide
- White Nolu-Clean antimicrobial polyamide

Bearing materials:

- Chrome steel
- Stainless Steel

Nolu-Clean[®]
White Bearings

A new antimicrobial material for improved hygiene. Created through new technology which will help equipment builders meet the requirements of the USDA and other government agencies as they relate to the prevention of contamination of food products and the growth of bacteria.

All bearing support units are also available without caps if desired. See **Solusii.com** or the Solus catalog for in stock part numbers.





Low Maintenance • Corrosion Resistant

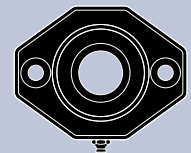
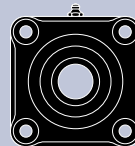

UCPA

UCFG

UCF

UCFL

- Tapped base design
- 2 bolt mounting
- Interchangeable with cast iron version

Inch shaft dia. sizes:
3/4, 1, 1-1/4

Millimeter shaft dia. sizes:
20, 25, 30

Housing materials:

- Black polyamide
- White Nolu-Clean antimicrobial polyamide

Bearing materials:

- Chrome steel
- Stainless Steel

- Solid housing
- 3 bolt mounting
- Interchangeable with cast iron version

Inch shaft dia. sizes:
1, 1-1/4

Millimeter shaft dia. sizes:
25, 30

Housing materials:

- Black polyamide

Bearing materials:

- Chrome steel
- Stainless Steel

- Economical
- 4 bolt mounting
- Interchangeable with cast iron version

Inch shaft dia. sizes:
3/4, 1, 1-1/4, 1-7/16, 1-1/2

Millimeter shaft dia. sizes:
20, 25, 30, 35, 40

Housing materials:

- Black polyamide

Bearing materials:

- Chrome steel
- Stainless Steel

- Economical
- 2 bolt mounting
- Interchangeable with cast iron version

Inch shaft dia. sizes:
3/4, 1, 1-1/4, 1-7/16

Millimeter shaft dia. sizes:
20, 25, 30, 35

Housing materials:

- Black polyamide

Bearing materials:

- Chrome steel
- Stainless Steel

Polypropylene material can be special ordered. For the full range of bearing configurations, see SystemPlastUSA.com or the System Plast Bearing Line catalog.



Solus 
A System Plast Group Company

**Four Brands
One Source**





Mounted Bearings With Caps and Seals

- Clean
- Strong
- Corrosion resistant
- Low maintenance

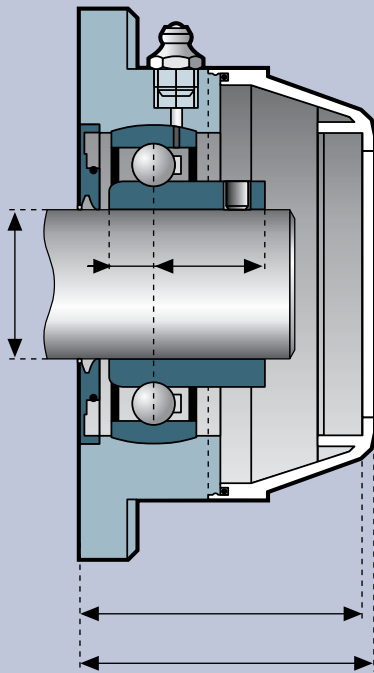

Nolu-Clean[®]

A new antimicrobial material for improved hygiene. Created through new technology which will help equipment builders meet the requirements of the USDA and other government agencies as they relate to the prevention of contamination of food products and the growth of bacteria.



For use in:

- Food and beverage industry
- Chemical applications
- Pharmaceutical
- Agriculture
- Material handling

Bearing units feature:

- Thermoplastic FDA cap material
- Fiberglass reinforced thermoplastic housing
- Stainless steel insert option
- Special long-life grease lubrication
- Constant application and thermal stability
- Self alignment - will adjust to a misaligned straight shaft up to 2.5°
- Solid housings for HACCP needs

Ideal applications:

- Humid conditions
- Wet areas
- Alkaline and acidic conditions
- Frequent wash down areas



Cap and seal system keeps contaminants out and lubrication in the bearing. Mounted bearings are also available without caps if desired.

Harsh Environment Performance Advantage

Plastic covers lock in place and seal against high pressure washdown. Bearing stays free of liquids and particulates so inserts do not rust or fail prematurely.



Contacting Customer Service

Toll free

phone: **(866) 765-8744**

S O L U S I I

fax: **(866) 447-6587**

4 4 S O L U S



30152 Aventura Rancho Santa Margarita, California 92688 phone: (949) 589-3900 fax: (949) 858-0300
Aston, Pennsylvania • Indianapolis, Indiana • Sanford, North Carolina

solusteam@solusii.com

www.solusii.com

© 2003 Solus Industrial Innovations, LLC 8/06