

Rod Ends and Spherical Plain Bearings

Rod ends and spherical plain bearings are designed to support a load, accommodate angular motion, misalignment and oscillation in mechanical motion systems. Rod ends consist of a threaded housing with an integral spherical plain bearing or a threaded housing formed around a ball. Spherical plain bearings consist of an outer race and hardened spherical ball. Spherical plain bearings provide a similar function as rod ends and require housing support.

Bearing Configurations

Male And Female Thread Types In Right And Left Hand Threads With The Option Of Grease Fittings.

Mounting Requirements

Light Press Or Mechanical Fit, Threaded Rod.

Bore Size Range

3/16" To 2"

Materials Housing & Balls







Carbon Steel, Alloy Steel, Stainless Steel

Races

Carbon Steel, Bronze, Delrin^{*}, Stainless And PTFE Liners

* The following trade names, trademarks and/or registered trademarks are used in this material by Regal Power Transmission Solutions are NOT owned or controlled by Regal Power Transmission Solutions and are believed to be owned by the following parties: Delrin; E.I. du Pont de Nemurs and Company. Regal Power Transmission Solutions cannot and does not represent or warrant the accuracy of this information.

Rod End Selection Guide

Brand	Image	Product Series	Housing / Race Material	Bore Size Range
Sealmaster Rod Ends		AR / ARE	HT Steel / Steel	3/16" - 3/4"
		ARE-20	HT Steel / Steel	3/16" - 3/4"
		TR / TRE	Steel / Steel	3/16" - 1"
		CFF-T / CFM-T	Steel / PTFE Liner	3/16" - 1"
		TF / TM	Steel / Bronze	3/16" - 3/4"
		CFF / CFM	Steel	3/16" - 1"
		CTFD / CTMD	Steel / Delrin*	3/16" - 3/4"

HT = Heat Treated
 SS = Stainless Steel

* The following trade names, trademarks and/or registered trademarks are used in this material by Regal Power Transmission Solutions are NOT owned or controlled by Regal Power Transmission Solutions and are believed to be owned by the following parties: Delrin; E.I. du Pont de Nemours and Company. Regal Power Transmission Solutions cannot and does not represent or warrant the accuracy of this information.











DESIGN CHARACTERISTICS				FEATURES					
Static Load	Reversing Load	Shock Load	Relative Base Cost	Construction	Max Temp. (°F)	Grease Fitting	Left Hand Thread	Y-Stud	Page No.
			\$\$\$	3 Piece	350	Optional	Standard	---	J-13, J-15
			\$\$\$	3 Piece	350	Optional	Standard	---	J-14
			\$	3 Piece	350	Optional	Standard	Optional	J-16 to J-17
			\$\$	2 Piece	250	---	Standard	Optional	J-18 to J-19
			\$	3 Piece	350	Optional	Standard	Optional	J-20 to J-21
			\$	2 Piece	350	Optional	Standard	Optional	J-22 to J-23
			\$	3 Piece	150	---	-Standard-	Optional	J-24 to J-25

○ = Not Recommended



Poor ← → Best

Spherical Plain Bearings Selection Guide

Brand	Image	Product Series	Outer / Race Material	Bore Size Range
Sealmaster Spherical Plain Bearings		SBG	Bronze / Steel Ball	3/16" - 1"
		SBG-S	HT Steel / Steel Ball	3/16" - 1"
		SBG-SA	HT Steel / Steel Ball	1/2" - 1"
		SBG-SS	SS / SS Ball	3/16" - 1"
		COR	SS / SS Ball	3/16" - 1"
		COM	Steel / Steel Ball	3/16" - 1"
		FLBG	Steel Outer / Bronze Race / Steel Ball	3/16" - 1"
Sealmaster Heavy Duty Spherical Plain Bearings		BTS-LS	Steel / Steel Ball	3/4" - 1 1/2"
		BH-LS	Steel / Steel Ball	1" - 2"

HT = Heat Treated
 SS = Stainless Steel

DESIGN CHARACTERISTICS				FEATURES				
Static Load	Reversing Load	Shock Load	Relative Base Cost	Construction	Max Temp. (°F)	Groove on Ball ID and Inter-connecting Hole	Seal	Page No.
			\$	2 Piece	350	---	---	J-32
			\$	2 Piece	350	---	---	J-32
			\$	2 Piece	350	Standard	---	J-32
			\$\$	2 Piece	500	---	---	J-32
			\$\$	2 Piece	500	---	---	J-33
			\$	2 Piece	350	---	---	J-34
			\$\$	3 Piece	350	---	---	J-35
			\$\$\$	2 Piece	250	---	Standard	J-36
			\$\$\$	2 Piece	350	---	---	J-37

○ = Not Recommended



Poor ← → Best

Sealmaster Rod Ends Bearings

Sealmaster two and three piece rod end bearing housing designs have been optimized for overall strength. This housing advantage and variety of outer race materials including brass, steel, DELRIN*, and PTFE liners provide a wide selection of application solutions. Sealmaster rod end bearings can be joined together or connected with a threaded rod or tube as linkage assemblies for flexibility in motion transfer. In addition Sealmaster rod end bearings can accommodate angular misalignment to provide ease in assembly and smooth motion transfer in a variety of applications.

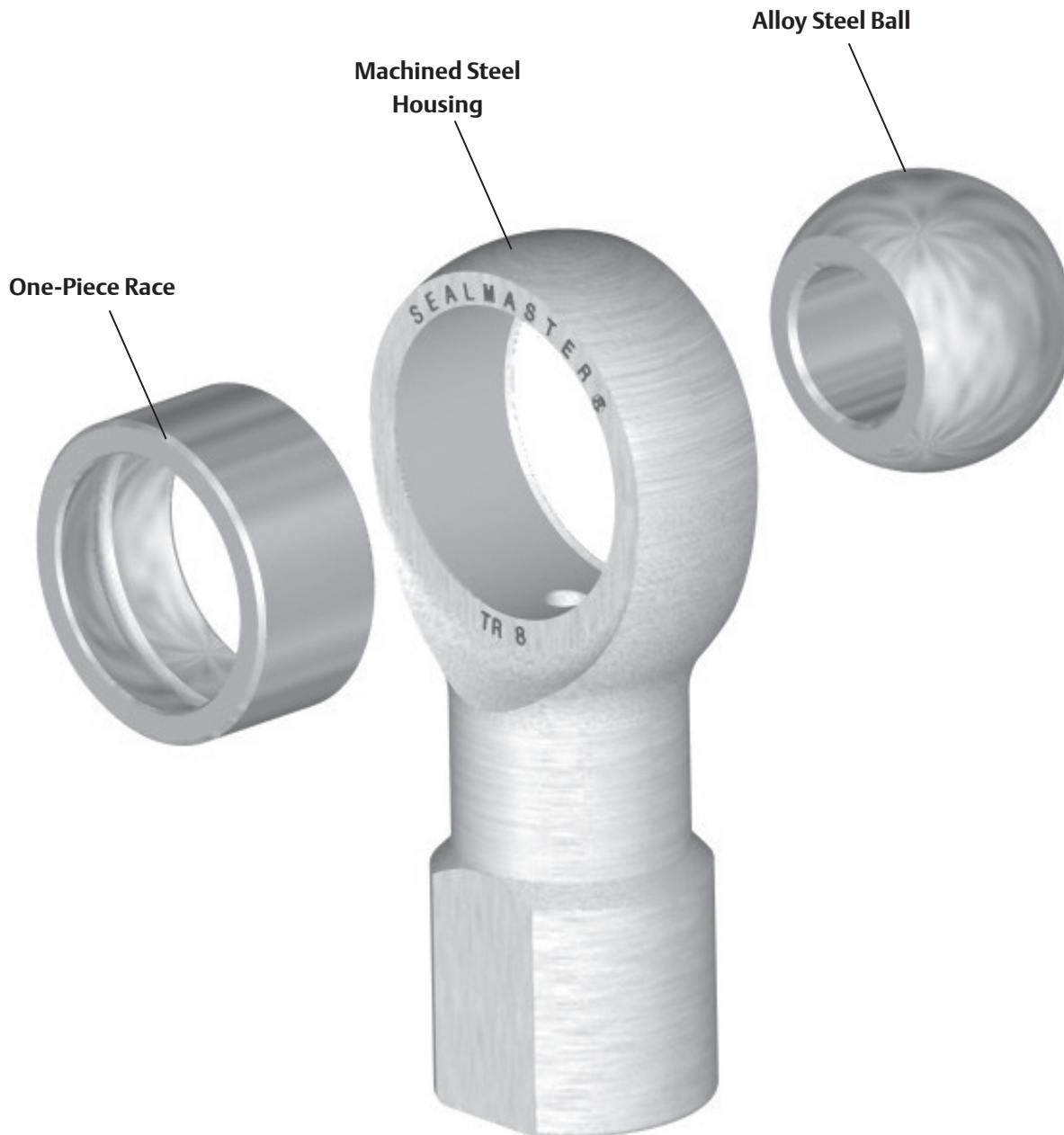

* The following trade names, trademarks and/or registered trademarks are used in this material by Regal Power Transmission Solutions are NOT owned or controlled by Regal Power Transmission Solutions and are believed to be owned by the following parties: Delrin; E.I. du Pont de Nemours and Company. Regal Power Transmission Solutions cannot and does not represent or warrant the accuracy of this information.

Rod End Bearing Nomenclature

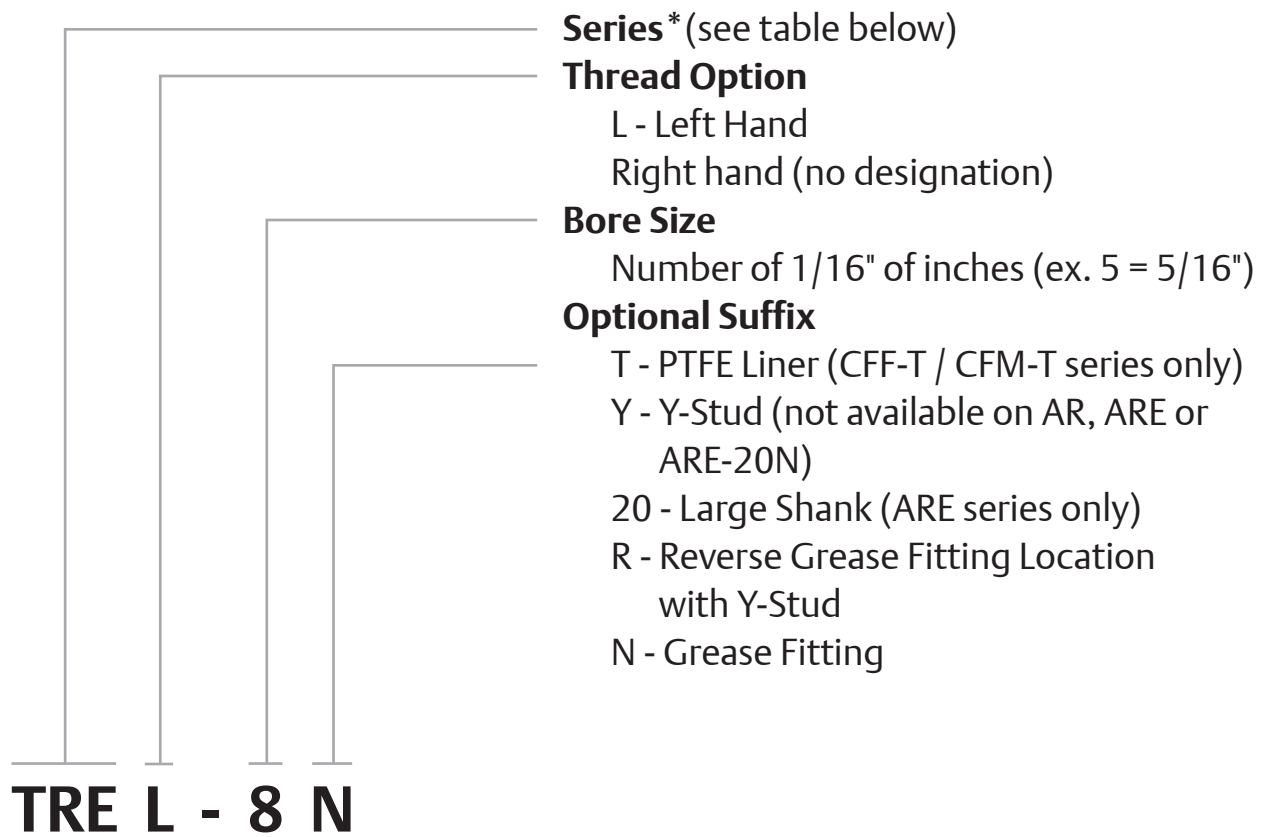

*Series	Description
TR	Three Piece Rod End (Internal Threads)
TRE	Three Piece Rod End (Male External Threads)
AR	Alloy Rod End (Internal Threads)
ARE	Alloy Rod End (External Threads)
CFF	Commercial Female (Internal Threads)
CFM	Commercial Male (External Threads)
TF	Three Piece Female (Internal Threads)
TM	Three Piece Male (External Threads)
CTFD	Commercial Three Piece Female Delrin* (Internal Threads)
CTMD	Commercial Three Piece Male DELRIN (External Threads)

* The following trade names, trademarks and/or registered trademarks are used in this material by Regal Power Transmission Solutions are NOT owned or controlled by Regal Power Transmission Solutions and are believed to be owned by the following parties: Delrin;E.I. du Pont de Nemurs and Company. Regal Power Transmission Solutions cannot and does not represent or warrant the accuracy of this information.

Features and Benefits

Three-Piece Rod Ends

Sealmaster three-piece rod ends incorporate a one-piece race formed around a hardened steel chrome plated ball in a controlled manufacturing process. Three-piece construction offers flexibility for alternative race materials designed to help solve specific application problems. Consult Application Engineering for material combinations available to meet your application needs.



Machined Steel Housing

- Protective coated for corrosion resistance
- Higher average tensile strength and fatigue life vs. competition
- Wrench flat on female rod ends facilitates assembly
- Full catalog thread depth for maximum thread engagement



One-piece Race

- Reduces pound-out in applications with high frequency oscillation, vibration or shock loading
- Improved spherical ball-race conformity for even load distribution
- Precision ball-race fit
- Less wear than rod ends with two-piece race designs
- Manufactured in steel, aluminum bronze and self lubricating Delrin®



Ball

- Alloy steel heat treated and chrome plated for corrosion resistance
- Better wear resistance properties than carbon steel tin nickel plated balls

Two-Piece Rod Ends

Sealmaster two-piece design rod ends consist of a machined housing formed around a hardened steel chrome plated ball. This construction offers more load capacity than three-piece designs with like housing materials because of greater housing cross section.



Machined Steel Housing

- Protective coated for corrosion resistance
- Wrench flat on female rod ends facilitates assembly



Ball

- Alloy steel, heat treated, chrome plated for wear resistance properties



Multiple Configurations



AR



ARE



ARE-N

Sealmaster AR, ARE and ARE-20N Precision Series Extra Capacity Rod Ends

- Three-piece design rod ends with heat treated alloy steel housing for high static, radial loads. The construction also helps reduce "pound-out" in applications with high frequency oscillation, vibration or shock loading.
- One-piece carbon steel outer race with protective coating for corrosion resistance
- Alloy steel, heat treated, chrome plated ball for wear resistance properties
- Wrench flat on female rod ends facilitates assembly
- Bore sizes form 3/16" to 3/4"
- Grease fittings available on 1/4" through 3/4" bore sizes
- Male and female versions with right and left hand threads
- The ARE-20N Series offers an oversized shank for additional shank strength



CFF-T



CFM-T

Sealmaster CFF-T and CFM-T Precision Two Piece Rod Ends

- Two piece construction with self-lubricating PTFE liner for applications where grease lubrication is not practical or desirable
- Manufactured with consistent, no load, rotational torque values for accurate linkage control
- Machined carbon steel housings with protective coating for corrosion resistance
- Alloy steel, heat treated, chrome plated ball for wear resistance properties
- Wrench flat on female rod ends facilitates assembly
- Bore sizes form 3/16" to 3/4"
- Male and female versions with right and left hand threads



TR



TRE

Sealmaster TR and TRE Precision Series Rod Ends

- Three-piece construction to help reduce "pound-out" in applications with high frequency oscillation, vibration or shock loading
- One-piece carbon steel outer race with protective coating for corrosion resistance
- Alloy steel, heat treated, chrome plated ball for wear resistance properties
- Wrench flat on female rod ends facilitates assembly
- Bore sizes from 3/16" to 1"
- Grease fittings available on 1/4" through 1" bore sizes
- Male and female versions in both right and left hand threads

Multiple Configurations continued

Sealmaster TF/TM, CFF/CFM, CTFD, CTMD Commercial Series Rod Ends

- Two and three-piece design
- Variety of material and construction combinations
- Machined carbon steel housings with protective coating for corrosion resistance
- Alloy steel, heat treated, chrome plated ball for wear resistance properties
- Wrench flat on female rod ends facilitates assembly
- Bore sizes from 3/16" to 3/4"
- Grease fitting available on CFF/CFM and TF/TM series in 1/4" through 3/4" bore sizes
- Male and female versions in both right and left hand threads



TF



TM

TF and TM

- TF and TM series is designed with one-piece bronze race for lower coefficient of friction.



CFF



CFM

CFF and CFM

- CFF and CFM series with two piece construction has a greater housing cross section and increased load capacity than three piece rod ends with like housing materials.
- The commercial CFF, CFM series provides a lower cost alternative to the precision grade three piece rod ends with like housing material.



CTFD



CTMD

CTFD and CTMD

- CTFD and CTMD series with self-lubricating Delrin* race for light duty applications where oil and grease should be avoided.
- The rod end utilizes a DELRIN acetal resin race material with lower coefficient of friction than metal to metal versions.
- Delrin material withstands vibration without galling or fretting and absorbs little moisture compared to bearings with nylon races.

* The following trade names, trademarks and/or registered trademarks are used in this material by Regal Power Transmission Solutions are NOT owned or controlled by Regal Power Transmission Solutions and are believed to be owned by the following parties: Delrin; E.I. du Pont de Nemours and Company. Regal Power Transmission Solutions cannot and does not represent or warrant the accuracy of this information.



Multiple Configurations continued



CFF-Y





Sealmaster Rod Ends with Y-Studs

- Y-studs are available on Sealmaster TR/TRE, TR-N/TRE-N, CFF/CFM, CFF-N/CFM-N and CTFD/CTMD rod ends bore sizes from 3/16" to 3/4".
- They are designed to facilitate right angle connections and accommodates up to ± 25 degrees of angular misalignment in any direction.
- The Y-stud contains a hex wrench flat to facilitate assembly advantages and are manufactured from carbon steel and plated for corrosion protection.
- Caution when selecting rod ends with Y-studs: Catalog load ratings are not applicable with Y-studs because of the reduced stud strength due to bending. For load ratings with Y-stud contact Application Engineering.



Design Modifications

Sealmaster rod ends can be ordered with the following design modifications at an extra cost.

Stock Modifications	Design Modifications	Option Offered on These Series	Ordering Instructions and Example for Specifying
	Zerk Type Fitting	AR, ARE, ARE-20, TR, TRE, TF, TM, CFF, CFM	Add "N" to part number suffix Example: TRE-8N (available on sizes 4-16 only) Caution: Catalog load ratings of rod ends are not applicable when grease fittings are specified, because of the reduced cross section of the head. When selecting rod ends with grease fittings, consult Application Engineering for static load capacities.
	Y-Studs	TR, TRE, TF, TM, CFF, CFM, CFF-T, CFM-T, CTFD, CTMD	Add "Y" to part number suffix Example: TRE-8Y (see page J-37 for stud specifications) Caution when selecting rod ends with Y-studs: Catalog load ratings are not applicable with Y-studs because of the reduced stud strength due to bending. For load ratings with Y-stud contact Application Engineering.
Special Modifications	Design Modifications	Option Offered on These Series	Ordering Instructions and Example for Specifying
	Alloy Steel Race	AR, ARE, ARE-20, TR, TRE	Add "S" to part number suffix Example ARE-8S
	Stainless Steel Race	AR, ARE, ARE-20, TR, TRE	Add "SS" to part number suffix Example TRE-6SS

Rod End Bearings **SEALMASTER**®



- Basic Construction Type:** Female 3 pc. Extra Capacity, Precision
- Outer Member Material:** Alloy Steel, Heat Treated Protective Plating for Corrosion Resistance
- Race Material:** Carbon Steel with Protective Plating for Corrosion Resistance
- Ball Material:** Alloy Steel, Heat Treated, Chrome Plated

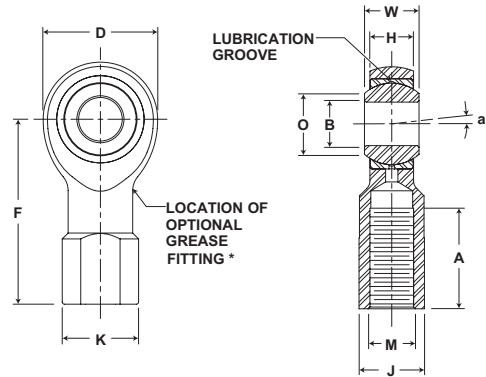

AR, AR-N Series Rod Ends

Part No.	Dimensions inch / mm											Max Static Radial Load lb/N	Misalignment Angle a Deg. +/-	Unit Wt. lb/kg
	B	W	H	D	F	A	M	K	J	Ball Diam.	O			
	+0.015 -0.005	+0.00 -0.005	+0.005 -0.005	+0.010 -0.010	+0.010 -0.010	Min.	Class UNF-3B	Ref.	+0.010 -0.010	Ref.	Ref.			
AR-3	.1900	.312	.250	.625	1.062	.531	#10-32	.375	.312	.437	.306	3700	6 1/2	.030
	4.826	7.92	6.35	15.88	26.97	13.49		9.53	7.92	11.10	7.77	16458		
AR-4	.2500	.375	.281	.750	1.312	.719	1/4-28	.469	.375	.500	.331	5370	8	.060
	6.350	9.53	7.14	19.05	33.32	18.26		11.91	9.53	12.70	8.41	23887		
AR-5	.3125	.437	.344	.875	1.375	.719	5/16-24	.531	.437	.625	.447	7500	7	.080
	7.938	11.10	8.74	22.23	34.93	18.26		13.49	11.10	15.88	11.35	33362		
AR-6	.3750	.500	.406	1.000	1.625	.906	3/8-24	.688	.562	.718	.517	9570	6	.140
	9.525	12.70	10.31	25.40	41.28	23.01		17.48	14.27	18.24	13.13	42569		
AR-7	.4375	.562	.437	1.125	1.812	1.031	7/16-20	.750	.625	.812	.586	11000	7	.180
	11.113	14.27	11.10	28.58	46.02	26.19		19.05	15.88	20.62	14.88	48930		
AR-8	.5000	.625	.500	1.312	2.125	1.156	1/2-20	.875	.750	.937	.698	13500	6	.290
	12.700	15.88	12.70	33.32	53.98	29.36		22.23	19.05	23.80	17.73	60051		
AR-10	.6250	.750	.562	1.500	2.500	1.469	5/8-18	1.000	.875	1.125	.839	17300	8	.430
	15.875	19.05	14.27	38.10	63.50	37.31		25.40	22.23	28.58	21.31	76954		
AR-12	.7500	.875	.687	1.750	2.875	1.719	3/4-16	1.125	1.000	1.312	.978	23200	7	.640
	19.050	22.23	17.45	44.45	73.03	43.66		28.58	25.40	33.32	24.84	103199		

NOTES

1. Rod ends with Zerk type grease fittings can be obtained by ordering the AR-N series; Example: AR-8N.
2. Grease fittings are available on sizes 4 through 12 only.
- *3. Load ratings apply to the AR series only. For AR-N load ratings contact Application Engineering.
4. To order left hand threaded units add letter "L" to part number prefix; Example: ARL-8.
5. For design modifications, see page J-13.

Metric dimensions for reference only.

Not all parts are available from stock. Please contact customer service for availability (800) 626-2120.

For more information on bearing capabilities outside of our standard offering, please contact Application Engineering (800) 626-2093.

SEALMASTER® Rod End Bearings



- Basic Construction Type:** Male 3 pc. Extra Capacity, Precision
- Outer Member Material:** Alloy Steel, Heat Treated Protective Plating for Corrosion Resistance
- Race Material:** Carbon Steel with Protective Plating for Corrosion Resistance
- Ball Material:** Alloy Steel, Heat Treated, Chrome Plated
- Feature:** Large Shank

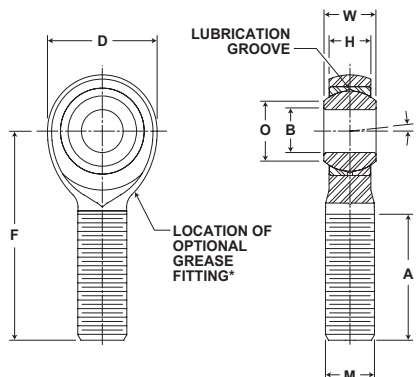

ARE-20, ARE-20N Series Male Rod Ends

Part No.	Dimensions inch / mm									Max Static Radial Load lb/N	Misalignment Angle a	Unit Wt. lb/kg
	B	W	H	D	F	A	M	Ball Diam.	O			
	+0.015 -0.005	+0.000 -0.005	+0.005 -0.005	+0.010 -0.010	+0.010 -0.010	Min.	Class UNF-3A	Ref.	Ref.			
ARE-3-20	.1900	.312	.250	.625	1.250	.719	1/4-28	.437	.306	3700	6 1/2	.030
	4.826	7.92	6.35	15.88	31.75	18.26		11.10	7.77	16458		.014
ARE-4-20	.2500	.375	.281	.750	1.562	.969	5/16-24	.500	.331	5370	8	.060
	6.350	9.53	7.14	19.05	39.67	24.61		12.70	8.41	23887		.027
ARE-5-20	.3125	.437	.344	.875	1.875	1.219	3/8-24	.625	.447	7500	7	.090
	7.938	11.10	8.74	22.23	47.63	30.96		15.88	11.35	33362		.041
ARE-6-20	.3750	.500	.406	1.000	1.938	1.219	7/16-20	.718	.517	9570	6	.130
	9.525	12.70	10.31	25.40	49.23	30.96		18.24	13.13	42569		.059
ARE-7-20	.4375	.562	.437	1.125	2.125	1.344	1/2-20	.812	.586	11000	7	.180
	11.113	14.27	11.10	28.58	53.98	34.14		20.62	14.88	48930		.082
ARE-8-20	.5000	.625	.500	1.312	2.438	1.469	5/8-18	.937	.698	13500	6	.300
	12.700	15.88	12.70	33.32	61.93	37.31		23.80	17.73	60051		.136
ARE-10-20	.6250	.750	.562	1.500	2.625	1.594	3/4-16	1.125	.839	17300	8	.460
	15.875	19.05	14.27	38.10	66.68	40.49		28.58	21.31	76954		.209
ARE-12-20	.7500	.875	.687	1.750	2.875	1.719	7/8-14	1.312	.978	23200	7	.720
	19.050	22.23	17.45	44.45	73.03	43.66		33.32	24.84	103199		.327

NOTES

1. Rod ends with Zerk type grease fittings can be obtained by ordering the ARE-20N series; Example: ARE-8-20N.
2. Grease fittings are available on sizes 4 through 12 only.
- *3. Load ratings apply to the ARE-20 series only. For ARE-20N load ratings contact Application Engineering.
4. To order left hand threaded units add letter "L" to part number prefix; Example: AREL-8-20.
5. For design modifications, see page J-13.

Metric dimensions for reference only.

Not all parts are available from stock. Please contact customer service for availability (800) 626-2120.

For more information on bearing capabilities outside of our standard offering, please contact Application Engineering (800) 626-2093.

Rod End Bearings **SEALMASTER**®



Basic Construction Type: Male 3 pc. Extra Capacity, Precision

Outer Member Material: Alloy Steel, Heat Treated Protective Plating for Corrosion Resistance

Race Material: Carbon Steel with Protective Plating for Corrosion Resistance

Ball Material: Alloy Steel, Heat Treated, Chrome Plated

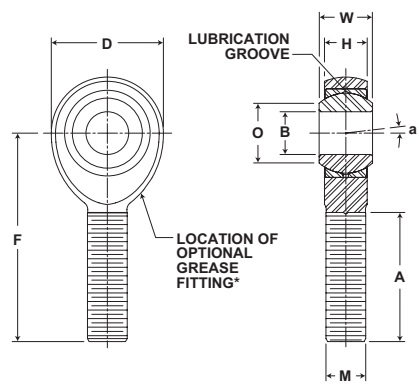

ARE, ARE-N Series Male Rod Ends

Part No.	Dimensions inch / mm									Max Static Radial Load lb/N	Misalignment Angle a Deg. +/-	Unit Wt. lb/kg
	B	W	H	D	F	A	M	Ball Diam.	O			
	+0.0015 -0.0005	+0.000 -0.005	+0.005 -0.005	+0.010 -0.010	+0.010 -0.010	Min.	Class UNF-3A	Ref.	Ref.			
ARE-3	.1900	.312	.250	.625	1.250	.719	#10-32	.437	.306	2850	6 1/2	.030
	4.826	7.92	6.35	15.88	31.75	18.26		11.10	7.77	12677		.014
ARE-4	.2500	.375	.281	.750	1.562	.969	1/4-28	.500	.331	4480	8	.050
	6.350	9.53	7.14	19.05	39.67	24.61		12.70	8.41	19928		.023
ARE-5	.3125	.437	.344	.875	1.875	1.219	5/16-24	.625	.447	7280	7	.080
	7.938	11.10	8.74	22.23	47.63	30.96		15.88	11.35	32383		.036
ARE-6	.3750	.500	.406	1.000	1.938	1.219	3/8-24	.718	.517	9580	6	.120
	9.525	12.70	10.31	25.40	49.23	30.96		18.24	13.13	42614		.054
ARE-7	.4375	.562	.437	1.125	2.125	1.344	7/16-20	.812	.586	11000	7	.170
	11.113	14.27	11.10	28.58	53.98	34.14		20.62	14.88	48930		.077
ARE-8	.5000	.625	.500	1.312	2.438	1.469	1/2-20	.937	.698	13500	6	.260
	12.700	15.88	12.70	33.32	61.93	37.31		23.80	17.73	60051		.118
ARE-10	.6250	.750	.562	1.500	2.625	1.594	5/8-18	1.125	.839	17300	8	.410
	15.875	19.05	14.27	38.10	66.68	40.49		28.58	21.31	76954		.186
ARE-12	.7500	.875	.687	1.750	2.875	1.719	3/4-16	1.312	.978	23200	7	.640
	19.050	22.23	17.45	44.45	73.03	43.66		33.32	24.84	103199		.290

- NOTES
1. Rod ends with Zerk type grease fittings can be obtained by ordering the ARE-N series; Example: ARE-8N.
 2. Grease fittings are available on sizes 4 through 12 only.
 - *3. Load ratings apply to the ARE series only. For ARE-N load ratings contact Application Engineering.
 4. To order left hand threaded units add letter "L" to part number prefix; Example: AREL-8.
 5. For design modifications, see page J-13.

SEALMASTER® Rod End Bearings



- Basic Construction Type:** Female 3 pc. General Purpose, Precision
- Outer Member Material:** Carbon Steel with Protective Plating for Corrosion Resistance
- Race Material:** Carbon Steel with Protective Plating for Corrosion Resistance
- Ball Material:** Alloy Steel, Heat Treated, Chrome Plated

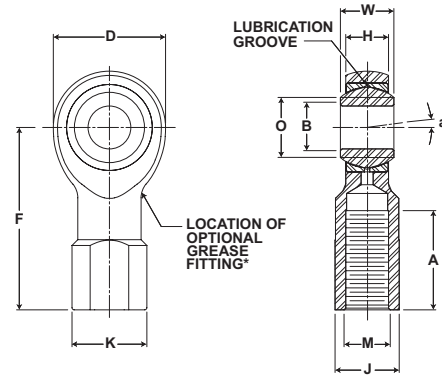

TR, TR-N Series Female Rod Ends

Part No.	Dimensions inch / mm											Max Static Radial Load lb/N	Misalignment Angle a Deg. +/-	Unit Wt. lb/kg
	B	W	H	D	F	A	M	K	J	Ball Diam.	O			
	+0.0015 -0.0005	+0.000 -0.005	+0.005 -0.005	+0.010 -0.010	+0.015 -0.015	Min.	Class UNF-2B	Ref.	+0.010 -0.010	Ref.	Ref.			
TR-3	.1900 4.826	.312 7.92	.250 6.35	.625 15.88	1.062 26.97	.531 13.49	#10-32	.375 9.53	.312 7.92	.437 11.10	.306 7.77	1850 8229	6 1/2	.030 .014
TR-4	.2500 6.350	.375 9.53	.281 7.14	.750 19.05	1.312 33.32	.719 18.26	1/4-28	.469 11.91	.375 9.53	.500 12.70	.331 8.41	2700 12010	8	.060 .027
TR-5	.3125 7.938	.437 11.10	.344 8.74	.875 22.23	1.375 34.93	.719 18.26	5/16-24	.531 13.49	.437 11.10	.625 15.88	.447 11.35	3350 14902	7	.080 .036
TR-6	.3750 9.525	.500 12.70	.406 10.31	1.000 25.40	1.625 41.28	.906 23.01	3/8-24	.688 17.48	.562 14.27	.718 18.24	.517 13.13	4450 19795	6	.140 .064
TR-7	.4375 11.113	.562 14.27	.437 11.10	1.125 28.58	1.812 46.02	1.031 26.19	7/16-20	.750 19.05	.625 15.88	.812 20.62	.586 14.88	5350 23798	7	.180 .082
TR-8	.5000 12.700	.625 15.88	.500 12.70	1.312 33.32	2.125 53.98	1.156 29.36	1/2-20	.875 22.23	.750 19.05	.937 23.80	.698 17.73	7400 32917	6	.290 .132
TR-10	.6250 15.875	.750 19.05	.562 14.27	1.500 38.10	2.500 63.50	1.469 37.31	5/8-18	1.000 25.40	.875 22.23	1.125 28.58	.839 21.31	8050 35808	8	.430 .195
TR-12	.7500 19.050	.875 22.23	.687 17.45	1.750 44.45	2.875 73.03	1.719 43.66	3/4-16	1.125 28.58	1.000 25.40	1.312 33.32	.978 24.84	11300 50265	7	.640 .290
** TR-16	1.0000 25.400	1.375 34.93	1.000 25.40	2.750 69.85	4.125 104.78	2.094 53.19	1 1/4-12	1.688 42.88	1.500 38.10	1.875 47.63	1.269 32.23	21000 93413	8 1/2	2.250 1.021

NOTES

1. Rod ends with Zerk type grease fittings can be obtained by ordering the TR-N series; Example: TR-8N.
2. Grease fittings are available on sizes 4 through 16 only.
- *3. Load ratings apply to the TR series only. For TR-N load ratings contact Application Engineering.
4. To order left hand threaded units add letter "L" to part number prefix; Example: TRL-8.
5. Add letter "Y" to the part number suffix to indicate stud. Example: TR-8Y.
6. For design modifications, see page J-13.
- **7. Tolerances for "D" dimensions is +.030, -.010. For "H" dimensions is +.030, -.010.

Metric dimensions for reference only.

Not all parts are available from stock. Please contact customer service for availability (800) 626-2120.

For more information on bearing capabilities outside of our standard offering, please contact Application Engineering (800) 626-2093.

Rod End Bearings **SEALMASTER**®



Basic Construction Type: Male 3 pc. General Purpose, Precision

Outer Member Material: Carbon Steel with Protective Plating for Corrosion Resistance

Race Material: Carbon Steel with Protective Plating for Corrosion Resistance

Ball Material: Alloy Steel, Heat Treated, Chrome Plated

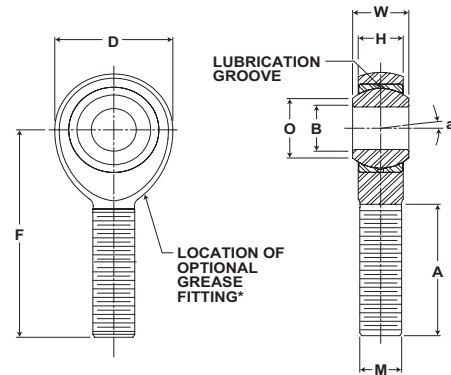

TRE, TRE-N Series Female Rod Ends

Part No.	Dimensions inch / mm									Max Static Radial Load lb/N	Misalignment Angle a Deg. +/-	Unit Wt. lb/kg
	B	W	H	D	F	A	M	Ball Diam.	O			
	+0.0015 -0.0005	+0.000 -0.005	+0.005 -0.005	+0.010 -0.010	+0.015 -0.015	Min.	Class UNF-3A	Ref.	Ref.			
TRE-3	.1900 4.826	.312 7.92	.250 6.35	.625 15.88	1.250 31.75	.719 18.26	#10-32	.437 11.10	.306 7.77	900 4003	6 1/2	.030 .014
TRE-4	.2500 6.350	.375 9.53	.281 7.14	.750 19.05	1.562 39.67	.969 24.61	1/4-28	.500 12.70	.331 8.41	1700 7562	8	.050 .023
TRE-5	.3125 7.938	.437 11.10	.344 8.74	.875 22.23	1.875 47.63	1.219 30.96	5/16-24	.625 15.88	.447 11.35	2500 11121	7	.080 .036
TRE-6	.3750 9.525	.500 12.70	.406 10.31	1.000 25.40	1.938 49.23	1.219 30.96	3/8-24	.718 18.24	.517 13.13	4000 17793	6	.120 .054
TRE-7	.4375 11.113	.562 14.27	.437 11.10	1.125 28.58	2.125 53.98	1.344 34.14	7/16-20	.812 20.62	.586 14.88	5000 22241	7	.170 .077
TRE-8	.5000 12.700	.625 15.88	.500 12.70	1.312 33.32	2.438 61.93	1.469 37.31	1/2-20	.937 23.80	.698 17.73	7000 31138	6	.260 .118
TRE-10	.6250 15.875	.750 19.05	.562 14.27	1.500 38.10	2.625 66.68	1.594 40.49	5/8-18	1.125 28.58	.839 21.31	8050 35808	8	.410 .186
TRE-12	.7500 19.050	.875 22.23	.687 17.45	1.750 44.45	2.875 73.03	1.719 43.66	3/4-16	1.312 33.32	.978 24.84	11300 50265	7	.640 .290
** TRE-16	1.0000 25.400	1.375 34.93	1.000 25.40	2.750 69.85	4.125 104.78	2.094 53.19	1 1/4-12	1.875 47.63	1.269 32.23	21000 93413	8 1/2	2.250 1.021

NOTES

1. Rod ends with Zerk type grease fittings can be obtained by ordering the TRE-N series; Example: TRE-8N.
2. Grease fittings are available on sizes 4 through 16 only.
- *3. Load ratings apply to the TRE series only. For TRE-N load ratings contact Application Engineering.
4. To order left hand threaded units add letter "L" to part number prefix; Example: TREL-8.
5. Add letter "Y" to the part number suffix to indicate stud; Example: TRE-8Y.
6. For design modifications, see page J-13.
- ** 7. Tolerances for "D" Dimension is +.030, -.010. For "H" Dimension is +.030, -.010.



Basic Construction Type: Female 2 pc. General Purpose, Precision

Outer Member Material: Carbon Steel with Protective Plating for Corrosion Resistance

Ball Material: Alloy Steel, Heat Treated, Chrome Plated

Feature: PTFE Fabric Liner

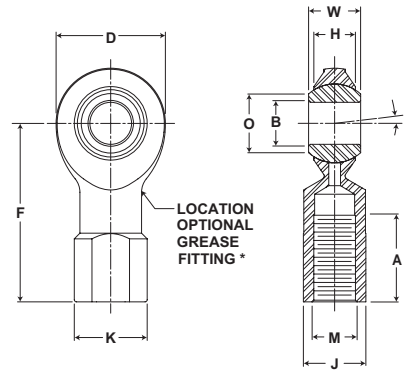

CFF-T Series Female Rod Ends

Part No.	Dimensions inch / mm											Max Static Radial Load lb/N	Misalignment Angle a	Unit Wt. lb/kg
	B	W	H	D	F	A	M	K	J	Ball Diam.	O			
	+0.015 -0.005	+0.000 -0.005	+0.015 -0.015	+0.031 -0.031	+0.015 -0.015	Min.	Class UNF-2B	Ref.	+0.010 -0.010	Ref.	Ref.			
CFF-3T	.1900	.312	.250	.625	1.062	.469	#10-32	.375	.312	.437	.306	865	6 1/2	.030
	4.826	7.92	6.35	15.88	26.97	11.91		9.53	7.92	11.10	7.77	3848		.014
CFF-4T	.2500	.375	.281	.750	1.312	.656	1/4-28	.469	.375	.500	.331	1550	8	.060
	6.350	9.53	7.14	19.05	33.32	16.66		11.91	9.53	12.70	8.41	6895		.027
CFF-5T	.3125	.437	.344	.875	1.375	.656	5/16-24	.531	.437	.625	.447	2080	7	.080
	7.938	11.10	8.74	22.23	34.93	16.66		13.49	11.10	15.88	11.35	9252		.036
CFF-6T	.3750	.500	.406	1.000	1.625	.781	3/8-24	.688	.562	.718	.517	2950	6	.140
	9.525	12.70	10.31	25.40	41.28	19.84		17.48	14.27	18.24	13.13	13122		.064
CFF-7T	.4375	.562	.437	1.125	1.812	.906	7/16-20	.750	.625	.812	.586	3160	7	.180
	11.113	14.27	11.10	28.58	46.02	23.01		19.05	15.88	20.62	14.88	14056		.082
CFF-8T	.5000	.625	.500	1.312	2.125	1.031	1/2-20	.875	.750	.937	.698	4920	6	.290
	12.700	15.88	12.70	33.32	53.98	26.19		22.23	19.05	23.80	17.73	21885		.132
CFF-10T	.6250	.750	.562	1.500	2.500	1.344	5/8-18	1.000	.875	1.125	.839	5460	8	.430
	15.875	19.05	14.27	38.10	63.50	34.14		25.40	22.23	28.58	21.31	24287		.195
CFF-12T	.7500	.875	.687	1.750	2.875	1.531	3/4-16	1.125	1.000	1.312	.978	8300	7	.640
	19.050	22.23	17.45	44.45	73.03	38.89		28.58	25.40	33.32	24.84	36920		.290
CFF-16T	1.0000	1.375	1.000	2.750	4.125	2.000	1 1/4-12	1.688	1.500	1.875	1.269	21000	8 1/2	2.250
	25.400	34.93	25.40	69.85	104.78	50.80		42.88	38.10	47.63	32.23	93413		1.021

NOTES

1. To order left hand threaded units add letter "L" to part number prefix; Example: CFFL-8T.
2. "T" in part number prefix indicates PTFE liner.
3. Add letter "Y" to the part number suffix to indicate stud; Example: CFF-8TY.
4. For design modifications, see page J-13.

Metric dimensions for reference only.

Not all parts are available from stock. Please contact customer service for availability (800) 626-2120.

For more information on bearing capabilities outside of our standard offering, please contact Application Engineering (800) 626-2093.

Rod End Bearings **SEALMASTER®**



- Basic Construction Type:** Male 2 pc. General Purpose, Precision
- Outer Member Material:** Carbon Steel with Protective Plating for Corrosion Resistance
- Ball Material:** Alloy Steel, Heat Treated, Chrome Plated
- Feature:** PTFE Fabric Liner

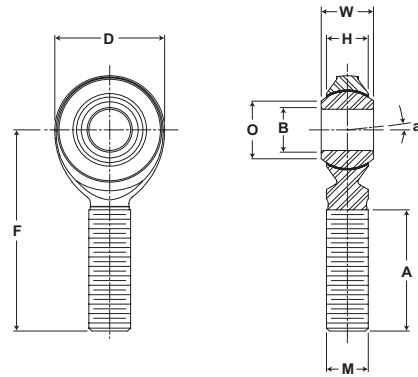

CFM-T Series Male Rod Ends

Part No.	Dimensions inch / mm									Max Static Radial Load lb/N	Misalignment Angle a Deg. +/-	Unit Wt. lb/kg
	B	W	H	D	F	A	M	Ball Diam.	O			
	+0.0015 -0.0005	+0.000 -0.005	+0.015 -0.015	+0.031 -0.031	+0.015 -0.015	Min.	Class UNF-3A	Ref.	Ref.			
CFM-3T	.1900	.312	.250	.625	1.250	.719	#10-32	.437	.306	865	6 1/2	.030
	4.826	7.92	6.35	15.88	31.75	18.26		11.10	7.77	3848		.014
CFM-4T	.2500	.375	.281	.750	1.562	.969	1/4-28	.500	.331	1550	8	.050
	6.350	9.53	7.14	19.05	39.67	24.61		12.70	8.41	6895		.023
CFM-5T	.3125	.437	.344	.875	1.875	1.219	5/16-24	.625	.447	2080	7	.080
	7.938	11.10	8.74	22.23	47.63	30.96		15.88	11.35	9252		.036
CFM-6T	.3750	.500	.406	1.000	1.938	1.219	3/8-24	.718	.517	2950	6	.120
	9.525	12.70	10.31	25.40	49.23	30.96		18.24	13.13	13122		.054
CFM-7T	.4375	.562	.437	1.125	2.125	1.344	7/16-20	.812	.586	3160	7	.170
	11.113	14.27	11.10	28.58	53.98	34.14		20.62	14.88	14056		.077
CFM-8T	.5000	.625	.500	1.312	2.438	1.469	1/2-20	.937	.698	4920	6	.260
	12.700	15.88	12.70	33.32	61.93	37.31		23.80	17.73	21885		.118
CFM-10T	.6250	.750	.562	1.500	2.625	1.594	5/8-18	1.125	.839	5460	8	.410
	15.875	19.05	14.27	38.10	66.68	40.49		28.58	21.31	24287		.186
CFM-12T	.7500	.875	.687	1.750	2.875	1.719	3/4-16	1.312	.978	8300	7	.640
	19.050	22.23	17.45	44.45	73.03	43.66		33.32	24.84	36920		.290
CFM-16T	1.0000	1.375	1.000	2.750	4.125	2.094	1 1/4-12	1.875	1.269	21000	8 1/2	2.250
	25.400	34.93	25.40	69.85	104.78	53.19		47.63	32.23	93413		1.021

NOTES

1. To order left hand threaded units add letter "L" to part number prefix. Example: CFML-8T.
2. "T" in part number prefix indicates PTFE liner.
3. Add letter "Y" to the part number suffix to indicate stud; Example: CFM-8TY.
4. For design modifications, see page J-13.



Basic Construction Type: Female 3 pc. General Purpose, Commercial

Outer Member Material: Carbon Steel with Protective Plating for Corrosion Resistance

Race Material: Bronze

Ball Material: Alloy Steel, Heat Treated, Chrome Plated

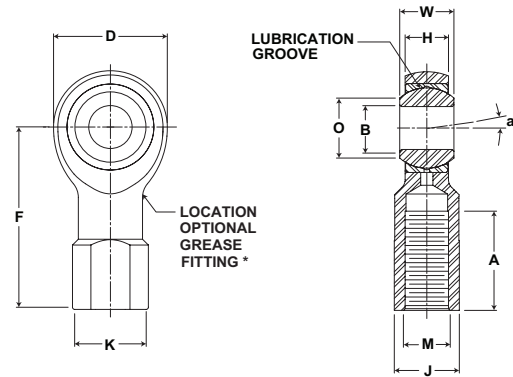

TF, TF-N Series Female Rod Ends

Part No.	Dimensions inch / mm											Max Static Radial Load lb/N	Misalignment Angle a	Unit Wt. lb/kg
	B	W	H	D	F	A	M	K	J	Ball Diam.	O			
	+0.0025 -0.0005	+0.000 -0.005	+0.010 -0.010	+0.031 -0.031	+0.015 -0.015	Min.	Class UNF-2B	Ref.	+0.010 -0.010	Ref.	Ref.			
TF-3	.1900	.312	.250	.625	1.062	.531	#10-32	.375	.312	.437	.306	1850	6 1/2	.030
	4.826	7.92	6.35	15.88	26.97	13.49		9.53	7.92	11.10	7.77	8229		.014
TF-4	.2500	.375	.281	.750	1.312	.719	1/4-28	.469	.375	.500	.331	2700	8	.060
	6.350	9.53	7.14	19.05	33.32	18.26		11.91	9.53	12.70	8.41	12010		.027
TF-5	.3125	.437	.344	.875	1.375	.719	5/16-24	.531	.437	.625	.447	3350	7	.080
	7.938	11.10	8.74	22.23	34.93	18.26		13.49	11.10	15.88	11.35	14902		.036
TF-6	.3750	.500	.406	1.000	1.625	.906	3/8-24	.688	.562	.718	.517	4450	6	.140
	9.525	12.70	10.31	25.40	41.28	23.01		17.48	14.27	18.24	13.13	19795		.064
TF-7	.4375	.562	.437	1.125	1.812	1.031	7/16-20	.750	.625	.812	.586	5350	7	.180
	11.113	14.27	11.10	28.58	46.02	26.19		19.05	15.88	20.62	14.88	23798		.082
TF-8	.5000	.625	.500	1.312	2.125	1.156	1/2-20	.875	.750	.937	.698	7400	6	.290
	12.700	15.88	12.70	33.32	53.98	29.36		22.23	19.05	23.80	17.73	32917		.132
TF-10	.6250	.750	.562	1.500	2.500	1.469	5/8-18	1.000	.875	1.125	.839	8050	8	.430
	15.875	19.05	14.27	38.10	63.50	37.31		25.40	22.23	28.58	21.31	35808		.195
TF-12	.7500	.875	.687	1.750	2.875	1.719	3/4-16	1.125	1.000	1.312	.978	11300	7	.640
	19.050	22.23	17.45	44.45	73.03	43.66		28.58	25.40	33.32	24.84	50265		.290

NOTES

1. Rod ends with Zerk type grease fittings can be obtained by ordering the TF-N series; Example: TF-8N.
2. Grease fittings are available on sizes 4 through 12 only.
- *3. Load ratings apply to the TF series only. For TF-N load ratings contact Application Engineering.
4. To order left hand threaded units add letter "L" to part number prefix; Example: TFL-8.
5. Add letter "Y" to the part number suffix to indicate stud; Example: TF-8Y.
6. For design modifications, see page J-13.

Metric dimensions for reference only.

Not all parts are available from stock. Please contact customer service for availability (800) 626-2120.

For more information on bearing capabilities outside of our standard offering, please contact Application Engineering (800) 626-2093.

Rod End Bearings **SEALMASTER**®



Basic Construction Type: Male 3 pc. General Purpose, Commercial

Outer Member Material: Carbon Steel with Protective Plating for Corrosion Resistance

Race Material: Bronze

Ball Material: Alloy Steel, Heat Treated, Chrome Plated

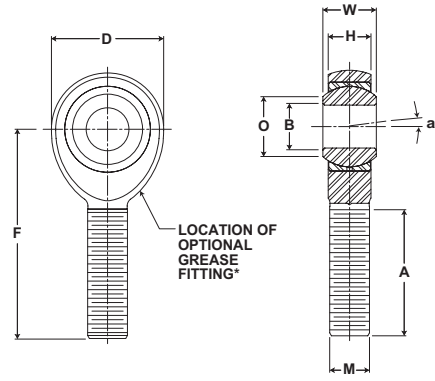

TM, TM-N Series Male Rod Ends

Part No.	Dimensions inch / mm									Max Static Radial Load lb/N	Misalignment Angle a	Unit Wt. lb/kg
	B	W	H	D	F	A	M	Ball Diam.	O			
	+0.0025 -0.0005	+0.000 -0.005	+0.010 -0.010	+0.031 -0.031	+0.015 -0.015	Min.	Class UNF-3A	Ref.	Ref.			
TM-3	.1900	.312	.250	.625	1.250	.719	#10-32	.437	.306	900	6 1/2	.030
	4.826	7.92	6.35	15.88	31.75	18.26		11.10	7.77	4003		.014
TM-4	.2500	.375	.281	.750	1.562	.969	1/4-28	.500	.331	1700	8	.050
	6.350	9.53	7.14	19.05	39.67	24.61		12.70	8.41	7562		.023
TM-5	.3125	.437	.344	.875	1.875	1.219	5/16-24	.625	.447	2500	7	.080
	7.938	11.10	8.74	22.23	47.63	30.96		15.88	11.35	11121		.036
TM-6	.3750	.500	.406	1.000	1.938	1.219	3/8-24	.718	.517	4000	6	.120
	9.525	12.70	10.31	25.40	49.23	30.96		18.24	13.13	17793		.054
TM-7	.4375	.562	.437	1.125	2.125	1.344	7/16-20	.812	.586	5000	7	.170
	11.113	14.27	11.10	28.58	53.98	34.14		20.62	14.88	22241		.077
TM-8	.5000	.625	.500	1.312	2.438	1.469	1/2-20	.937	.698	7000	6	.260
	12.700	15.88	12.70	33.32	61.93	37.31		23.80	17.73	31138		.118
TM-10	.6250	.750	.562	1.500	2.625	1.594	5/8-18	1.125	.839	8050	8	.410
	15.875	19.05	14.27	38.10	66.68	40.49		28.58	21.31	35808		.186
TM-12	.7500	.875	.687	1.750	2.875	1.719	3/4-16	1.312	.978	11300	7	.640
	19.050	22.23	17.45	44.45	73.03	43.66		33.32	24.84	50265		.290

NOTES

1. Rod ends with Zerk type grease fittings can be obtained by ordering the TM-N series; Example: TM-8N.
2. Grease fittings are available on sizes 4 through 12 only.
- *3. Load ratings apply to the TM series only. For TM-N load ratings contact Application Engineering.
4. To order left hand threaded units add letter "L" to part number prefix; Example: TML-8.
5. Add letter "Y" to the part number suffix to indicate stud; Example: TM-8Y.
6. For design modifications, see page J-13.



Basic Construction Type: Female 2 pc. General Purpose, Commercial

Outer Member Material: Carbon Steel with Protective Plating for Corrosion Resistance

Ball Material: Alloy Steel, Heat Treated, Chrome Plated

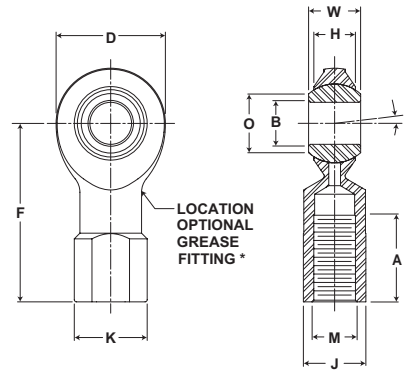

CFF, CFF-N Series Female Rod Ends

Part No.	Dimensions inch / mm											Max Static Radial Load lb/N	Misalignment Angle a	Unit Wt. lb/kg
	B	W	H	D	F	A	M	K	J	Ball Diam.	O			
	+0.0025 -0.0005	+0.005 -0.005	+0.015 -0.015	+0.031 -0.031	+0.015 -0.015	Min.	Class UNF-2B	Ref.	+0.010 -0.010	Ref.	Ref.			
CFF-3	.1900	.312	.250	.625	1.062	.469	#10-32	.375	.312	.437	.306	2000	6 1/2	.030
	4.826	7.92	6.35	15.88	26.97	11.91		9.53	7.92	11.10	7.77	8896		
CFF-4	.2500	.375	.281	.750	1.312	.656	1/4-28	.469	.375	.500	.331	3200	8	.060
	6.350	9.53	7.14	19.05	33.32	16.66		11.91	9.53	12.70	8.41	14234		
CFF-5	.3125	.437	.344	.875	1.375	.656	5/16-24	.531	.437	.625	.447	3800	7	.080
	7.938	11.10	8.74	22.23	34.93	16.66		13.49	11.10	15.88	11.35	16903		
CFF-6	.3750	.500	.406	1.000	1.625	.781	3/8-24	.688	.562	.718	.517	5000	6	.140
	9.525	12.70	10.31	25.40	41.28	19.84		17.48	14.27	18.24	13.13	22241		
CFF-7	.4375	.562	.437	1.125	1.812	.906	7/16-20	.750	.625	.812	.586	6500	7	.180
	11.113	14.27	11.10	28.58	46.02	23.01		19.05	15.88	20.62	14.88	28913		
CFF-8	.5000	.625	.500	1.312	2.125	1.031	1/2-20	.875	.750	.937	.698	9000	6	.290
	12.700	15.88	12.70	33.32	53.98	26.19		22.23	19.05	23.80	17.73	40034		
CFF-10	.6250	.750	.562	1.500	2.500	1.344	5/8-18	1.000	.875	1.125	.839	10000	8	.430
	15.875	19.05	14.27	38.10	63.50	34.14		25.40	22.23	28.58	21.31	44482		
CFF-12	.7500	.875	.687	1.750	2.875	1.531	3/4-16	1.125	1.000	1.312	.978	14000	7	.640
	19.050	22.23	17.45	44.45	73.03	38.89		28.58	25.40	33.32	24.84	62275		
CFF-16	1.0000	1.375	1.000	2.750	4.125	2.000	1 1/4-12	1.688	1.500	1.875	1.269	25200	8 1/2	2.250
	25.400	34.93	25.40	69.85	104.78	50.80		42.88	38.10	47.63	32.23	112095		

NOTES

1. Rod ends with Zerk type grease fittings can be obtained by ordering the CFF-N series; Example: CFF-8N.
2. Grease fittings are available on sizes 4 through 16 only.
- *3. Load ratings apply to the CFF series only. For CFF-N load ratings contact Application Engineering.
4. To order left hand threaded units add letter "L" to part number prefix; Example: CFFL-8.
5. Add letter "Y" to the part number suffix to indicate stud; Example: CFF-8Y.
6. For design modifications, see page J-13.

Metric dimensions for reference only.

Not all parts are available from stock. Please contact customer service for availability (800) 626-2120.

For more information on bearing capabilities outside of our standard offering, please contact Application Engineering (800) 626-2093.

Rod End Bearings **SEALMASTER**®



Basic Construction Type: Male 2 pc. General Purpose, Commercial

Outer Member Material: Carbon Steel with Protective Plating for Corrosion Resistance

Ball Material: Alloy Steel, Heat Treated, Chrome Plated

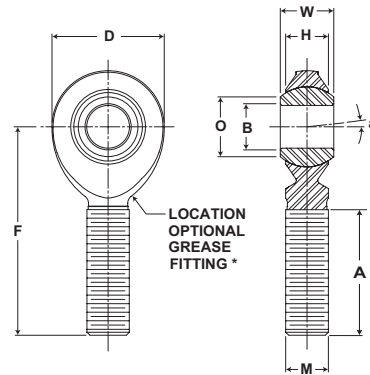

CFM, CFM-N Series Male Rod Ends

Part No.	Dimensions inch / mm									Max Static Radial Load lb/N	Misalignment Angle a Deg. +/-	Unit Wt. lb/kg
	B	W	H	D	F	A	M	Ball Diam.	O			
	+0.0025 -0.0005	+0.005 -0.005	+0.015 -0.015	+0.031 -0.031	+0.015 -0.015	Min.	Class UNF-3A	Ref.	Ref.			
CFM-3	.1900	.312	.250	.625	1.250	.719	#10-32	.437	.306	950	6 1/2	.030
	4.826	7.92	6.35	15.88	31.75	18.26		11.10	7.77			
CFM-4	.2500	.375	.281	.750	1.562	.969	1/4-28	.500	.331	2000	8	.050
	6.350	9.53	7.14	19.05	39.67	24.61		12.70	8.41			
CFM-5	.3125	.437	.344	.875	1.875	1.219	5/16-24	.625	.447	3000	7	.080
	7.938	11.10	8.74	22.23	47.63	30.96		15.88	11.35			
CFM-6	.3750	.500	.406	1.000	1.938	1.219	3/8-24	.718	.517	5000	6	.110
	9.525	12.70	10.31	25.40	49.23	30.96		18.24	13.13			
CFM-7	.4375	.562	.437	1.125	2.125	1.344	7/16-20	.812	.586	6500	7	.160
	11.113	14.27	11.10	28.58	53.98	34.14		20.62	14.88			
CFM-8	.5000	.625	.500	1.312	2.438	1.469	1/2-20	.937	.698	9000	6	.240
	12.700	15.88	12.70	33.32	61.93	37.31		23.80	17.73			
CFM-10	.6250	.750	.562	1.500	2.625	1.594	5/8-18	1.125	.839	10000	8	.400
	15.875	19.05	14.27	38.10	66.68	40.49		28.58	21.31			
CFM-12	.7500	.875	.687	1.750	2.875	1.719	3/4-16	1.312	.978	14000	7	.630
	19.050	22.23	17.45	44.45	73.03	43.66		33.32	24.84			
CFM-16	1.0000	1.375	1.000	2.750	4.125	2.094	1 1/4-12	1.875	1.269	25200	8 1/2	2.250
	25.400	34.93	25.40	69.85	104.78	53.19		47.63	32.23			

NOTES

1. Rod ends with Zerk type grease fittings can be obtained by ordering the CFM-N series; Example: CFM-8N.
2. Grease fittings are available on sizes 4 through 16 only.
- *3. Load ratings apply to the CFM series only. For CFM-N load ratings contact Application Engineering.
4. To order left hand threaded units add letter "L" to part number prefix; Example: CFML-8.
5. Add letter "Y" to the part number suffix to indicate stud; Example: CFM-8Y.
6. For design modifications, see page J-13.



- Basic Construction Type:** Female 3 pc. General Purpose, Commercial
- Outer Member Material:** Carbon Steel with Protective Plating for Corrosion Resistance
- Race Material:** Delrin*
- Ball Material:** Alloy Steel, Heat Treated, Chrome Plated
- Feature:** Self-Lubricating

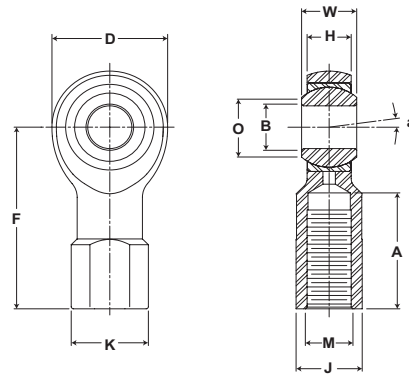

CTFD Series Female Rod Ends

Part No.	Dimensions inch / mm											Max Static Radial Load lb/N	Misalignment Angle a Deg. +/-	Unit Wt. lb/kg
	B	W	H	D	F	A	M	K	J	Ball Diam.	O			
	+0.0025 -0.0005	+0.005 -0.005	+0.010 -0.010	+0.031 -0.031	+0.015 -0.015	Min.	Class UNF-2B	Ref.	+0.010 -0.010	Ref.	Ref.			
CTFD-3	.1900 4.826	.312 7.92	.250 6.35	.625 15.88	1.062 26.97	.531 13.49	#10-32	.375 9.53	.312 7.92	.437 11.10	.306 7.77	800 3559	6 1/2	.030 .014
CTFD-4	.2500 6.350	.375 9.53	.281 7.14	.750 19.05	1.312 33.32	.719 18.26	1/4-28	.469 11.91	.375 9.53	.500 12.70	.331 8.41	1060 4715	8	.060 .027
CTFD-5	.3125 7.938	.437 11.10	.344 8.74	.875 22.23	1.375 34.93	.719 18.26	5/16-24	.531 13.49	.437 11.10	.625 15.88	.447 11.35	1570 6984	7	.080 .036
CTFD-6	.3750 9.525	.500 12.70	.406 10.31	1.000 25.40	1.625 41.28	.906 23.01	3/8-24	.688 17.48	.562 14.27	.718 18.24	.517 13.13	2150 9564	6	.140 .064
CTFD-7	.4375 11.113	.562 14.27	.437 11.10	1.125 28.58	1.812 46.02	1.031 26.19	7/16-20	.750 19.05	.625 15.88	.812 20.62	.586 14.88	2600 11565	7	.180 .082
CTFD-8	.5000 12.700	.625 15.88	.500 12.70	1.312 33.32	2.125 53.98	1.156 29.36	1/2-20	.875 22.23	.750 19.05	.937 23.80	.698 17.73	3420 15213	6	.290 .132
CTFD-10	.6250 15.875	.750 19.05	.562 14.27	1.500 38.10	2.500 63.50	1.469 37.31	5/8-18	1.000 25.40	.875 22.23	1.125 28.58	.839 21.31	4620 20551	8	.430 .195
CTFD-12	.7500 19.050	.875 22.23	.687 17.45	1.750 44.45	2.875 73.03	1.719 43.66	3/4-16	1.125 28.58	1.000 25.40	1.312 33.32	.978 24.84	6600 29358	7	.640 .290

NOTES

- To order left hand threaded units add letter "L" to part number prefix; Example: CTFDL-8.
- Add letter "Y" to the part number suffix to indicate stud; Example: CTFD-8Y.
- For design modifications, see page J-13.
- Caution: Prolonged exposure to ultraviolet light can cause loss of mechanical properties in DELRIN material. Consult Application Engineering for application assistance.

* The following trade names, trademarks and/or registered trademarks are used in this material by Regal Power Transmission Solutions are NOT owned or controlled by Regal Power Transmission Solutions and are believed to be owned by the following parties: Delrin; E.I. du Pont de Nemours and Company. Regal Power Transmission Solutions cannot and does not represent or warrant the accuracy of this information.

Metric dimensions for reference only.

Not all parts are available from stock. Please contact customer service for availability (800) 626-2120.

For more information on bearing capabilities outside of our standard offering, please contact Application Engineering (800) 626-2093.

Rod End Bearings **SEALMASTER**®



- Basic Construction Type:** Male 3 pc. General Purpose, Commercial
- Outer Member Material:** Carbon Steel with Protective Plating for Corrosion Resistance
- Race Material:** Delrin*
- Ball Material:** Alloy Steel, Heat Treated, Chrome Plated
- Feature:** Self-Lubricating

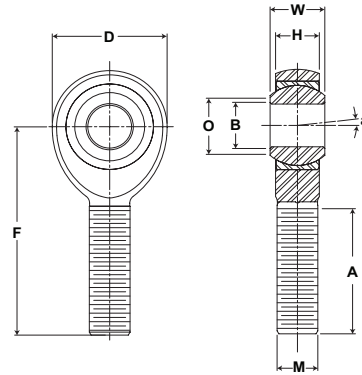

CTMD Series Male Rod Ends

Part No.	Dimensions inch / mm									Max Static Radial Load lb/N	Misalignment Angle a Deg. +/-	Unit Wt. lb/kg
	B	W	H	D	F	A	M	Ball Diam.	O			
	+0.0025 -0.0005	+0.005 -0.005	+0.010 -0.010	+0.031 -0.031	+0.015 -0.015	Min.	Class UNF-3A	Ref.	Ref.			
CTMD-3	.1900	.312	.250	.625	1.250	.719	#10-32	.437	.306	800	6 1/2	.030
	4.826	7.92	6.35	15.88	31.75	18.26		11.10	7.77	3559		.014
CTMD-4	.2500	.375	.281	.750	1.562	.969	1/4-28	.500	.331	1060	8	.050
	6.350	9.53	7.14	19.05	39.67	24.61		12.70	8.41	4715		.023
CTMD-5	.3125	.437	.344	.875	1.875	1.219	5/16-24	.625	.447	1570	7	.080
	7.938	11.10	8.74	22.23	47.63	30.96		15.88	11.35	6984		.036
CTMD-6	.3750	.500	.406	1.000	1.938	1.219	3/8-24	.718	.517	2150	6	.120
	9.525	12.70	10.31	25.40	49.23	30.96		18.24	13.13	9564		.054
CTMD-7	.4375	.562	.437	1.125	2.125	1.344	7/16-20	.812	.586	2600	7	.170
	11.113	14.27	11.10	28.58	53.98	34.14		20.62	14.88	11565		.077
CTMD-8	.5000	.625	.500	1.312	2.438	1.469	1/2-20	.937	.698	3420	6	.260
	12.700	15.88	12.70	33.32	61.93	37.31		23.80	17.73	15213		.118
CTMD-10	.6250	.750	.562	1.500	2.625	1.594	5/8-18	1.125	.839	4620	8	.410
	15.875	19.05	14.27	38.10	66.68	40.49		28.58	21.31	20551		.186
CTMD-12	.7500	.875	.687	1.750	2.875	1.719	3/4-16	1.312	.978	6600	7	.640
	19.050	22.23	17.45	44.45	73.03	43.66		33.32	24.84	29358		.290

NOTES

1. To order left hand threaded units add letter "L" to part number prefix; Example: CTMDL-8.
2. Add letter "Y" to the part number suffix to indicate stud; Example: CTMD-8Y.
3. For design modifications, see page J-13.
4. Caution: Prolonged exposure to ultraviolet light can cause loss of mechanical properties in DELRIN® material. Consult Application Engineering for application assistance.

* The following trade names, trademarks and/or registered trademarks are used in this material by Regal Power Transmission Solutions are NOT owned or controlled by Regal Power Transmission Solutions and are believed to be owned by the following parties: Delrin;E.I. du Pont de Nemours and Company. Regal Power Transmission Solutions cannot and does not represent or warrant the accuracy of this information.



Sealmaster Spherical Plain Bearings

Sealmaster spherical plain bearings perform a similar function as rod end bearings and must be supported in a housing. Sealmaster spherical plain bearings are designed with a variety of outer race materials including steel, heat treated steel, bronze, stainless steel and heat treated stainless steel for flexibility in a wide range of application requirements. In addition Sealmaster spherical plain bearings can accommodate angular misalignment to provide ease in assembly and smooth motion transfer in a variety of applications.

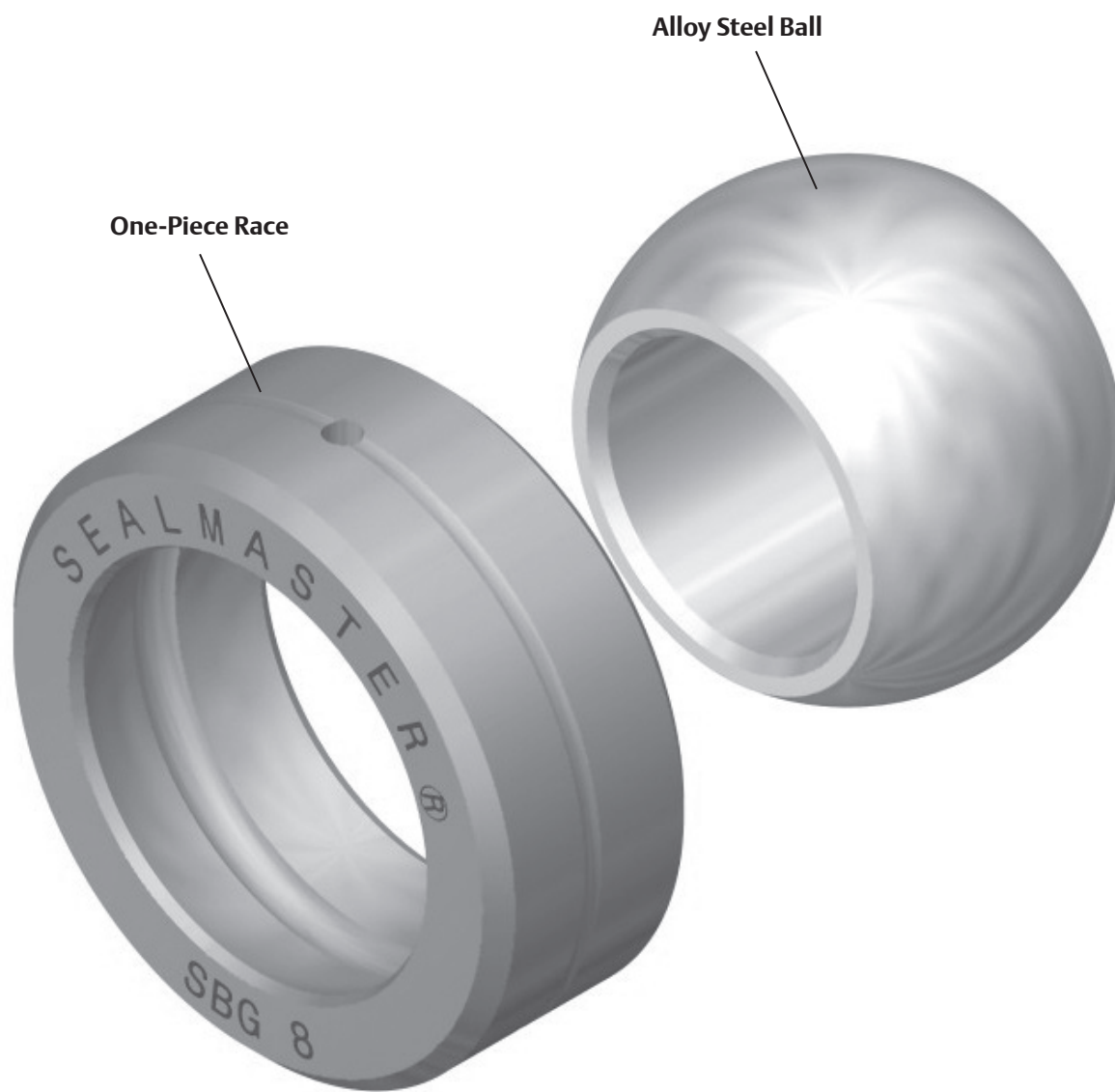



Spherical Plain Bearing Nomenclature

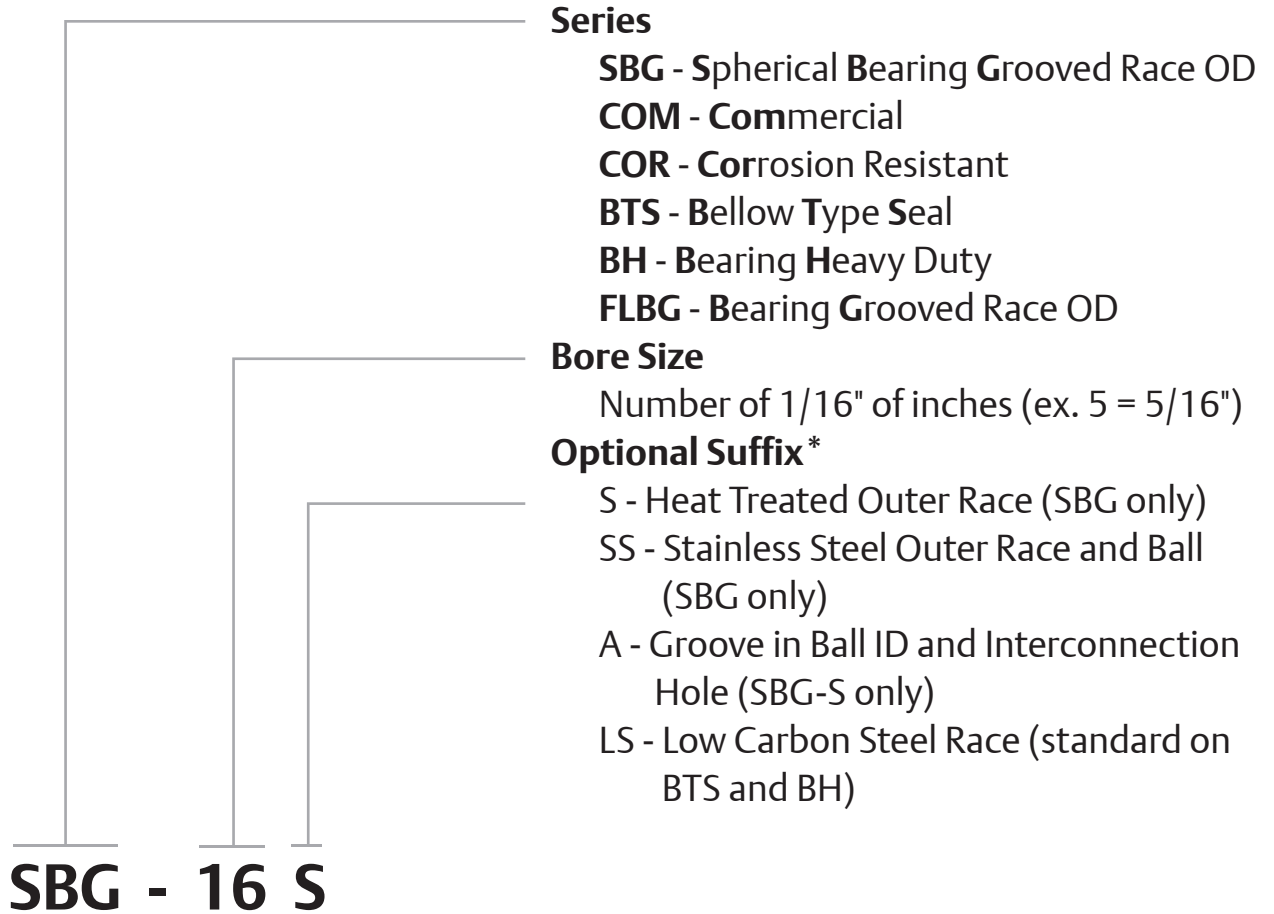

* Options listed may not be available on all sizes and configurations, refer to product tables or consult Application Engineering for more information.



Features and Benefits



One-piece Race

- Helps reduce pound-out in applications with high frequency oscillation, vibration or shock loading
- Improved spherical ball-race conformity for even load distribution
- Precision ball-race fit
- Outer race lubrication grooves and interconnecting hole in outer race to direct grease to the ball and race area. The outer races are chamfered to facilitate installation and retention into housings
- Steel, heat treated steel, stainless steel, and heat treated stainless steel materials

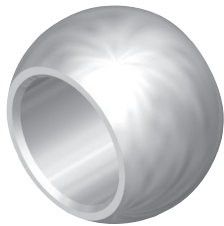

Ball

- Alloy steel heat treated and chrome plated for corrosion resistance
- Heat treated stainless steel balls for corrosion resistance

Multiple Configurations



Sealmaster SBG Precision Spherical Plain Bearings

- SBG series contain a bronze outer race and alloy steel, heat treated, chrome plated ball for wear resistance properties. This material combination provides for low coefficient of friction.



Sealmaster SBG-S Precision Spherical Plain Bearings

- SBG-S series utilize an alloy steel, heat treated outer race with protective coating for corrosion resistance and alloy steel, heat treated, chrome plated ball for wear resistance properties



Sealmaster SBG-SS Precision Spherical Plain Bearings

- SBG-SS series is manufactured with a 300 series stainless steel outer race for corrosion resistance and a stainless steel, heat treated ball for corrosion resistance.



Sealmaster SBG-SA Precision Spherical Plain Bearings

- SBG-SA series is the same as the SBG-S series and has a groove in ball ID and interconnecting hole to facilitate lubrication from the shaft into the bearing



Multiple Configurations continued



Sealmaster COR Precision Spherical Plain Bearings

- COR series spherical plain bearings have a stainless steel, heat treated outer race for strength and corrosion resistance and stainless steel, heat treated ball for corrosion resistance



Sealmaster FLBG Precision Spherical Plain Bearings

- FLBG series is available in with a carbon steel outer race with protective coating for corrosion resistance and bronze race. Also contains an alloy steel, heat treated, chrome plated ball for wear resistance properties



Sealmaster COM Commercial Series Spherical Plain Bearings

- Bore sizes from 3/16" to 1"
- Materials include a carbon steel outer race with protective coating for corrosion resistance with an alloy steel, heat treated, chrome plated ball for wear resistance properties
- Outer race lubrication grooves and interconnecting hole in outer race direct grease to the ball and race area. The outer races are chamfered to facilitate installation and retention into housings

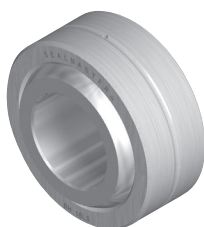

Sealmaster BH-LS Heavy Duty Spherical Plain Bearings

- Heavy duty bearings with radial static load capacities up to 221,000 lbs.
- Available in 1", 1-3/16", 1-1/4", 1-1/2", 1-3/4" and 2" bore sizes
- Materials include a carbon steel outer race with protective coating for corrosion resistance and alloy steel, heat treated, chrome plated ball for wear resistance properties
- Outer race lubrication grooves and interconnecting hole in outer race direct grease to the ball and race area. The outer races are chamfered to facilitate installation and retention into housings.



Multiple Configurations continued

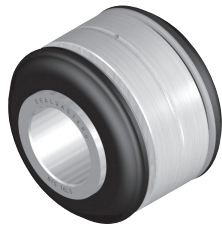

Sealmaster BTS-LS Sealed Spherical Plain Bearings

- This is a sealed design for applications where the bearing is exposed to dirt, dust, moisture and contaminants. They are available in four bore sizes (3/4", 1", 1-1/4" and 1-1/2")
- Materials include a carbon steel outer race with protective coating for corrosion resistance and alloy steel, heat treated, chrome plated ball for wear resistance properties
- Integral nitrile rubber "bellows type" seals misalign with the bearing and help reduce contaminant entry as well as seal in lubricant.
- Outer race lubrication grooves and interconnecting hole in outer race direct grease to the ball and race area. The outer races are chamfered to facilitate installation and retention into housings.

Design Modifications

Sealmaster spherical plain bearings can be ordered with the following design modifications at an extra cost.

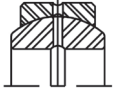
Special Modifications	Design Modifications	Option Offered on These Series	Ordering Instructions and Example for Specifying
	Groove on Ball I.D. and Interconnecting Hole	SBG	Add "A" to part number suffix Example: SBG-8A

Spherical Plain Bearings **SEALMASTER**®



Basic Construction Type: 2 pc. General Purpose, Precision

Race Material: Variable, See Below

Ball Material: Variable, See Below

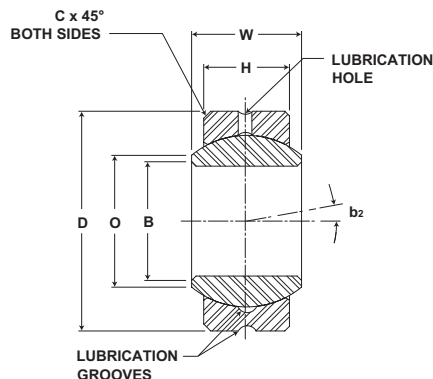

SBG, SBG-S, SBG-SA, SBG-SS Series Spherical Plain Bearings

Part No.	Part No.	Part No.	Part No.	Dimensions inch / mm							Max Static Radial Load lb/N				Misalignment Angle b_2	Unit Wt. lb/kg
				B	D	W	H	C	Ball Diam.	O	SBG	SBG-S	SBG-SA	SBG-SS	Deg. +/-	
				+0.000 -0.005	+0.000 -0.005	+0.000 -0.005	+0.005 -0.005	Ref.	Ref.	Ref.						
SBG-3	SBG-3S	-	SBG-3SS	.1900 4.826	.5625 14.288	.281 7.14	.218 5.54	.025 .64	.406 10.31	.293 7.44	2750 12233	6480 28824	- -	4400 19572	11 1/2	.020 .009
SBG-4	SBG-4S	-	SBG-4SS	.2500 6.350	.6562 16.667	.343 8.71	.250 6.35	.025 .64	.500 12.70	.364 9.25	4200 18683	10000 44482	- -	6700 29803	13 1/2	.020 .009
SBG-5	SBG-5S	-	SBG-5SS	.3125 7.938	.7500 19.050	.375 9.53	.281 7.14	.025 .64	.562 14.27	.419 10.64	5800 25800	13900 61830	- -	9200 40924	12	.030 .014
SBG-6	SBG-6S	-	SBG-6SS	.3750 9.525	.8125 20.638	.406 10.31	.312 7.92	.030 .76	.656 16.66	.515 13.08	7750 34474	18700 83182	- -	12400 55158	10	.040 .018
SBG-7	SBG-7S	-	SBG-7SS	.4375 11.113	.9062 23.017	.437 11.10	.343 8.71	.035 .89	.687 17.45	.530 13.46	9300 41368	22300 99195	- -	14900 66279	9 1/2	.050 .023
SBG-8	SBG-8S	SBG-8SA	SBG-8SS	.5000 12.700	1.0000 25.400	.500 12.70	.390 9.91	.035 .89	.781 19.84	.600 15.24	11200 49820	26900 119657	26900 119657	17900 79623	10	.070 .032
SBG-10	SBG-10S	SBG-10SA	SBG-10SS	.6250 15.875	1.1875 30.163	.625 15.88	.500 12.70	.035 .89	.968 24.59	.739 18.77	20000 88964	48000 213515	48000 213515	32000 142343	9	.120 .054
SBG-12	SBG-12S	SBG-12SA	SBG-12SS	.7500 19.050	1.4375 36.513	.750 19.05	.593 15.06	.045 1.14	1.187 30.15	.920 23.37	30000 133447	78000 346961	78000 346961	48000 213515	9	.210 .095
SBG-14	SBG-14S	SBG-14SA	SBG-14SS	.8750 22.225	1.5625 39.688	.875 22.23	.703 17.86	.045 1.14	1.312 33.32	.980 24.89	43000 191274	103000 458167	103000 458167	69000 306927	9 1/2	.270 .122
SBG-16	SBG-16S	SBG-16SA	SBG-16SS	1.0000 25.400	1.7500 44.450	1.000 25.40	.797 20.24	.045 1.14	1.500 38.10	1.118 28.40	52000 231308	125000 556028	125000 556028	83000 369202	9 1/2	.380 .172

NOTES:

1. Add letter "A" to suffix to indicate cross drilled oil hole in ball and race and a grooved I.D. on ball.
2. For design modifications, see page J-31.
3. For mounting information, see Recommended Housing Bore Diameters page J-43.

Material Specifications

SBG

Outer Race - Aluminum bronze
Ball - Alloy steel, heat treated, chrome plated

SBG-S

Outer Race - Alloy steel, heat treated with protective plating for corrosion resistance
Ball - Alloy steel, heat treated, chrome plated

SBG-SA

Outer Race - Alloy steel, heat treated with protective plating for corrosion resistance
Ball - Alloy steel, heat treated, chrome plated

SBG-SS

Outer Race - 300 series stainless steel
Ball - Stainless steel, heat treated

Metric dimensions for reference only.

Not all parts are available from stock. Please contact customer service for availability (800) 626-2120.

For more information on bearing capabilities outside of our standard offering, please contact Application Engineering (800) 626-2093.



Basic Construction Type: 2 pc. Corrosion Resistant, Precision

Race Material: Stainless Steel, Heat Treated

Ball Material: Stainless Steel, Heat Treated

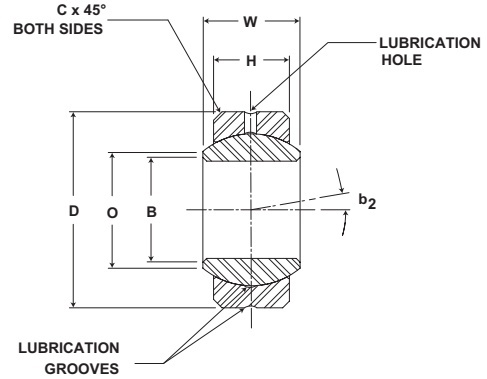

COR Series Spherical Plain Bearings

Part No.	Dimensions inch / mm							Max Static Radial Load lb/N	Misalignment Angle b_2 Deg. +/-	Unit Wt. lb/kg
	B	D	W	H	C	Ball Diam.	O			
	+0.0000 -0.0005	+0.0000 -0.0005	+0.000 -0.005	+0.005 -0.005	Ref.	Ref.	Ref.			
COR-3	.1900	.5625	.281	.218	.025	.406	.293	4800	11 1/2	.020 .009
	4.826	14.288	7.14	5.54	.64	10.31	7.44	21351		
COR-4	.2500	.6562	.343	.250	.025	.500	.364	7500	13 1/2	.020 .009
	6.350	16.667	8.71	6.35	.64	12.70	9.25	33362		
COR-5	.3125	.7500	.375	.281	.025	.562	.419	10400	12	.030 .014
	7.938	19.050	9.53	7.14	.64	14.27	10.64	46262		
COR-6	.3750	.8125	.406	.312	.030	.656	.515	14000	10	.040 .018
	9.525	20.638	10.31	7.92	.76	16.66	13.08	62275		
COR-8	.5000	1.0000	.500	.390	.035	.781	.600	20000	10	.070 .032
	12.700	25.400	12.70	9.91	.89	19.84	15.24	88964		
COR-10	.6250	1.1875	.625	.500	.035	.968	.739	36000	9	.120 .054
	15.875	30.163	15.88	12.70	.89	24.59	18.77	160136		
COR-12	.7500	1.4375	.750	.593	.045	1.187	.920	54000	9	.210 .095
	19.050	36.513	19.05	15.06	1.14	30.15	23.37	240204		
COR-14	.8750	1.5625	.875	.703	.045	1.312	.980	77000	9 1/2	.270 .122
	22.225	39.688	22.23	17.86	1.14	33.32	24.89	342513		
COR-16	1.0000	1.7500	1.000	.797	.045	1.500	1.118	93500	9 1/2	.380 .172
	25.400	44.450	25.40	20.24	1.14	38.10	28.40	415909		

NOTES

1. For mounting information, see Recommended Housing Bore Diameters, page J-43.

Metric dimensions for reference only.

Not all parts are available from stock. Please contact customer service for availability (800) 626-2120.

For more information on bearing capabilities outside of our standard offering, please contact Application Engineering (800) 626-2093.

Spherical Plain Bearings **SEALMASTER®**



- Basic Construction Type:** 2 pc. General Purpose, Commercial
- Race Material:** Carbon Steel with Protective Plating for Corrosion Resistance
- Ball Material:** Alloy Steel, Heat Treated, Chrome Plated

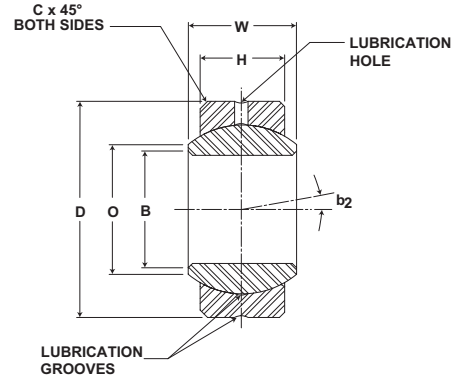

COM Series Spherical Plain Bearings

Part No.	Dimensions inch / mm							Max Static Radial Load lb/N	Misalignment Angle b_2 Deg. +/-	Unit Wt. lb/kg
	B	D	W	H	C	Ball Diam.	O			
	+0.0015 -0.0005	+0.0000 -0.0007	+0.000 -0.005	+0.005 -0.005	Ref.	Ref.	Ref.			
COM-3	.1900	.5625	.281	.218	.025	.406	.293	3250	11 1/2	.020
	4.826	14.288	7.14	5.54	.64	10.31	7.44	14457		.009
COM-4	.2500	.6562	.343	.250	.025	.500	.364	4900	13 1/2	.020
	6.350	16.667	8.71	6.35	.64	12.70	9.25	21796		.009
COM-5	.3125	.7500	.375	.281	.025	.562	.419	6450	12	.030
	7.938	19.050	9.53	7.14	.64	14.27	10.64	28691		.014
COM-6	.3750	.8125	.406	.312	.030	.656	.515	8250	10	.040
	9.525	20.638	10.31	7.92	.76	16.66	13.08	36698		.018
COM-7	.4375	.9062	.437	.343	.035	.687	.530	10200	9 1/2	.050
	11.113	23.017	11.10	8.71	.89	17.45	13.46	45372		.023
COM-8	.5000	1.0000	.500	.390	.035	.781	.600	13600	10	.070
	12.700	25.400	12.70	9.91	.89	19.84	15.24	60496		.032
COM-10	.6250	1.1875	.625	.500	.035	.968	.739	21000	9	.120
	15.875	30.163	15.88	12.70	.89	24.59	18.77	93413		.054
COM-12	.7500	1.4375	.750	.593	.045	1.187	.920	30000	9	.210
	19.050	36.513	19.05	15.06	1.14	30.15	23.37	133447		.095
COM-14	.8750	1.5625	.875	.703	.045	1.312	.980	41100	9 1/2	.270
	22.225	39.688	22.23	17.86	1.14	33.32	24.89	182822		.122
COM-16	1.0000	1.7500	1.000	.797	.045	1.500	1.118	54700	9 1/2	.380
	25.400	44.450	25.40	20.24	1.14	38.10	28.40	243318		.172

NOTES

1. For mounting information, see Recommended Housing Bore Diameters, page J-43.



Basic Construction Type: 3 pc. General Purpose, Precision

Outer Member Material: Carbon Steel with Protective Plating for Corrosion Resistance

Race Material: Bronze

Ball Material: Alloy Steel, Heat Treated, Chrome Plated

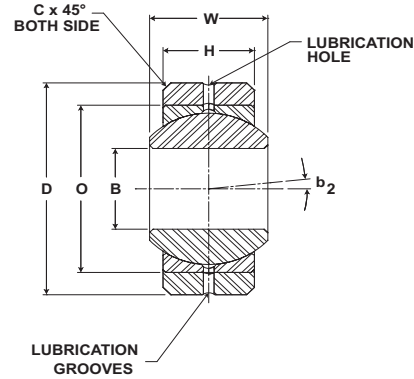

FLBG Series Spherical Plain Bearings

Part No.	Dimensions inch / mm							Max Static Radial Load lb/N	Misalignment Angle b_2 Deg. +/-	Unit Wt. lb/kg
	B	D	W	H	C	Ball Diam.	O			
	+0.0000 -0.0005	+0.0000 -0.0005	+0.000 -0.005	+0.005 -0.005	Ref.	Ref.	Ref.			
FLBG-3	.1900	.6250	.281	.187	.020	.406	.293	2960	16 1/2	.020
	4.826	15.875	7.14	4.75	.51	10.31	7.44	13167		.009
FLBG-4	.2500	.7500	.375	.281	.020	.500	.331	5240	14 1/2	.040
	6.350	19.050	9.53	7.14	.51	12.70	8.41	23309		.018
FLBG-5	.3125	.8750	.437	.313	.025	.625	.447	6550	14 1/2	.050
	7.938	22.225	11.10	7.95	.64	15.88	11.35	29136		.023
FLBG-6	.3750	1.0000	.500	.375	.025	.718	.517	8600	12 1/2	.080
	9.525	25.400	12.70	9.53	.64	18.24	13.13	38255		.036
FLBG-7	.4375	1.1875	.562	.437	.040	.812	.586	11100	11	.120
	11.113	30.163	14.27	11.10	1.02	20.62	14.88	49375		.054
FLBG-8	.5000	1.3125	.687	.531	.045	.937	.637	15600	12 1/2	.180
	12.700	33.338	17.45	13.49	1.14	23.80	16.18	69392		.082
FLBG-10	.6250	1.5625	.875	.687	.045	1.187	.802	25700	12	.330
	15.875	39.688	22.23	17.45	1.14	30.15	20.37	114319		.150
FLBG-12	.7500	2.2500	1.250	.937	.050	1.625	1.038	47600	15	.970
	19.050	57.150	31.75	23.80	1.27	41.28	26.37	211735		.440
FLBG-16	1.0000	2.3750	1.125	.875	.065	1.750	1.345	48200	10	.940
	25.400	60.325	28.58	22.23	1.65	44.45	34.16	214404		.426

NOTES

1. For mounting information, see Recommended Housing Bore Diameters, page J-43.

Metric dimensions for reference only.

Not all parts are available from stock. Please contact customer service for availability (800) 626-2120.

For more information on bearing capabilities outside of our standard offering, please contact Application Engineering (800) 626-2093.

Spherical Plain Bearings **SEALMASTER**®

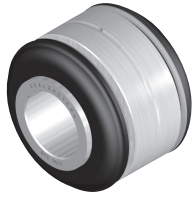

- Basic Construction Type:** 2 pc. Heavy Duty, Precision
- Race Material:** Carbon Steel with Protective Plating for Corrosion Resistance
- Ball Material:** Alloy Steel, Heat Treated, Chrome Plated
- Feature:** Nitrile Rubber Seals

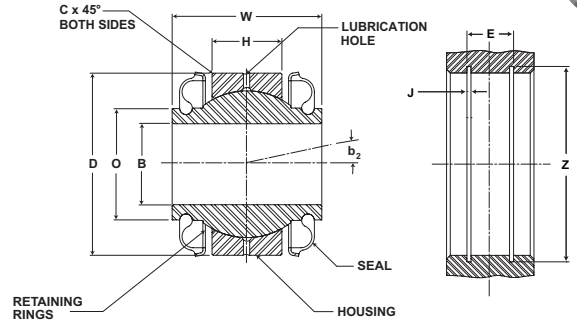

BTS-LS Series Spherical Plain Bearings

Part No.	Dimensions inch / mm											Max Static Radial Load lb/N	Misalignment Angle b_2 Deg. +/-	Unit Wt. lb/kg	Recommended Snap Ring
	B	D	W	H	C	Ball Diam.	O	Housing Width	E	Z	J				
	+0.0000 -0.0007	+0.0000 -0.0007	+0.000 -0.005	+0.005 -0.005	Ref.	Ref.	Ref.		Groove Spacing	Groove Diam.	Groove Width				
BTS-12LS	.7500	1.5000	1.250	.500	.015	1.250	1.000	1.250	.507	1.576/1.584	.056/0.060	31500 140119	13 1/2	.250 .113	TRUARC #5000-150
	19.050	38.100	31.75	12.70	.38	31.75	25.40	31.75	12.88	40.03/40.23	1.42/1.52				SPIROLOX #RR-150
BTS-16LS	1.0000	2.2500	1.875	.875	.015	1.813	1.375	1.687	.882	2.364/2.376	.086/0.091	83500 371427	12	.950 .431	TRUARC #5000-225
	25.400	57.150	47.63	22.23	.38	46.05	34.93	42.85	22.40	60.05/60.35	2.18/2.31				SPIROLOX #RR-225
BTS-20LS	1.2500	2.3750	1.875	.875	.015	2.000	1.625	1.687	.882	2.499/2.511	.086/0.091	94000 418133	9 1/2	.990 .449	TRUARC #5000-237
	31.750	60.325	47.63	22.23	.38	50.80	41.28	42.85	22.40	63.47/63.78	2.18/2.31				SPIROLOX #RR-237
BTS-24LS	1.5000	2.7500	1.875	1.000	.015	2.375	2.000	1.875	1.007	2.894/2.906	.103/0.108	130000 578269	7 1/2	1.440 .653	TRUARC #5000-275
	38.100	69.850	47.63	25.40	.38	60.33	50.80	47.63	25.58	73.51/73.81	2.62/2.74				SPIROLOX #RR-275

NOTES

1. Retaining rings are NOT furnished with the bearings.
2. For mounting information, see Recommended Housing Bore Diameters, page J-43.

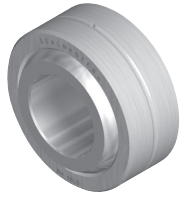

Basic Construction Type: 2 pc. Heavy Duty, Precision

Race Material: Carbon Steel with Protective Plating for Corrosion Resistance

Ball Material: Alloy Steel, Heat Treated, Chrome Plated

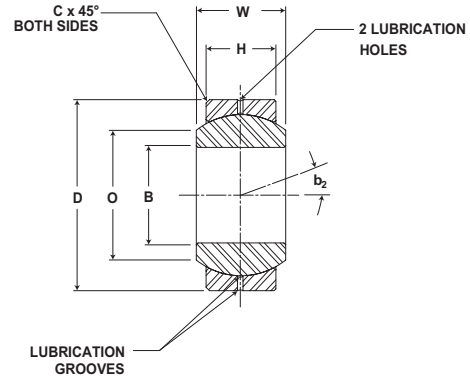

BH-LS Series Spherical Plain Bearings

Part No.	Dimensions inch / mm							Max Static Radial Load lb/N	Misalignment Angle b_2 Deg. +/-	Unit Wt. lb/kg
	B	D	W	H	C	Ball Diam.	O			
	+0.000 -0.007	+0.000 -0.007	+0.00 -0.05	+0.07 -0.07	Ref.	Ref.	Ref.			
BH-16LS	1.0000 25.400	2.0000 50.800	1.000 25.40	.781 19.84	.035 .89	1.687 42.85	1.360 34.54	69500 309151	9	.550 .249
BH-19LS	1.1875 30.163	2.3750 60.325	1.187 30.15	.937 23.80	.035 .89	2.000 50.80	1.610 40.89	100000 444822	8 1/2	.940 .426
BH-20LS	1.2500 31.750	2.3750 60.325	1.187 30.15	.937 23.80	.035 .89	2.000 50.80	1.610 40.89	100000 444822	8 1/2	.900 .408
BH-24LS	1.5000 38.100	2.7500 69.850	1.375 34.93	1.094 27.79	.035 .89	2.312 58.72	1.860 47.24	135000 600510	8	1.360 .617
BH-28LS	1.7500 44.450	3.1250 79.375	1.562 39.67	1.250 31.75	.040 1.02	2.625 66.68	2.110 53.59	178000 791783	8	1.950 .885
BH-32LS	2.0000 50.800	3.5000 88.900	1.750 44.45	1.375 34.93	.040 1.02	2.937 74.60	2.360 59.94	221000 983057	8 1/2	2.640 1.197

NOTES

1. For mounting information, see Recommended Housing Bore Diameters, page J-43.

Metric dimensions for reference only.

Not all parts are available from stock. Please contact customer service for availability (800) 626-2120.

For more information on bearing capabilities outside of our standard offering, please contact Application Engineering (800) 626-2093.



Rod Ends and Spherical Plain Bearing Engineering Section

Sealmaster Rods Ends with Y-Studs

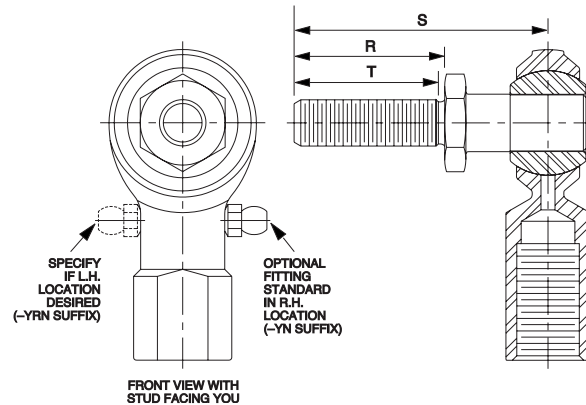

Stud Size	Dimensions in inch				Thread Size Class UNF-2A
	R +.031 -.031	S +.031 -.031	T Min.		
-3	.500	.968	7/16		#10-32
-4	.562	1.047	1/2		1/4-28
-5	.687	1.234	19/32		5/16-24
-6	.906	1.540	13/16		3/8-24
-7	1.125	1.930	1		7/16-20
-8	1.125	2.000	1		1/2-20
-10	1.500	2.500	1 3/8		5/8-18
-12	1.812	3.000	1 5/8		3/4-16

Rod Ends with Y-Studs are available in the following series:

- | | |
|-----------------|-----------------|
| CTFD-Y, CTFDL-Y | TF-Y, TFL-Y |
| CTMD-Y, CTMDL-Y | TF-YN, TFL-YN |
| CFF-Y, CFFL-Y | TM-Y, TML-Y |
| CFF-YN, CFFL-YN | TM-YN, TML-YN |
| CFM-Y, CFML-Y | TR-Y, TRL-Y |
| CFM-YN, CFML-YN | TR-YN, TRL-YN |
| CFF-TY, CFFL-TY | TRE-Y, TREL-Y |
| CFM-TY, CFML-TY | TRE-YN, TREL-YN |

- Sealmaster Y-studs are available with the above rod end series to facilitate right angle connections in a variety of linkage applications.
- To order, add the letter Y to the rod end part number; Example: TR-8Y.
- Sealmaster Y-studs are manufactured from carbon steel and plated for corrosion resistance.
- They are secured in the rod end bore, threaded and manufactured with a hex wrench flat.
- Rod ends with Y-studs can accommodate up to ± 25 degrees of angular misalignment in any direction for linkage design flexibility.
- Y-stud thread sizes are the same as the corresponding rod end and are available in right hand threads only.

Caution: When selecting rod ends with Y-studs: Catalog load ratings are not applicable with Y-studs because of the reduced stud strength due to bending. For load ratings with Y-studs contact Application Engineering.



Rod Ends and Spherical Plain Bearing Engineering Section

Sealmaster rod ends can be joined together or connected with a threaded rod or tube to form linkage assemblies allowing design engineers flexibility in transferring motion between points with long center distances.

Normal operation of rod ends results in wear of the raceways or fatigue or fracture of the outer member. Give consideration to this in the design of the equipment. Spherical plain bearings provide a similar function as rod ends and must be supported in a housing. Spherical plain bearings afford customers greater load rating per equivalent rod end bore size. This occurs because rod end load capacity is controlled by the head and shank geometry. Spherical plain bearings have a larger bearing area and generally are less restricted by the housing material or dimensions in which they are mounted.

Load Ratings Rod Ends

Static radial load ratings are applied perpendicular to the bearing ball bore and are a function of strength of race and housing materials. Sealmaster static load ratings listed in this catalog are maximum working loads and factors of safety should be applied as necessary. External conditions including mounting components, bolts, pins and housings should be considered separately when designing this product into an application. Static axial load ratings are applied parallel or through the bearing ball bore. In general, rod ends are not intended to carry axial loads. Applications of rod ends with axial loading should be reviewed with Application Engineering.

Spherical Bearings

Static radial load ratings listed in the catalog are based on a maximum permanent set in the bearing race of .2% of normal ball diameter.

Static axial load ratings are approximately 20% of the radial static load ratings listed with each unit. Caution should be exercised in designing adequate housings to support spherical bearings.

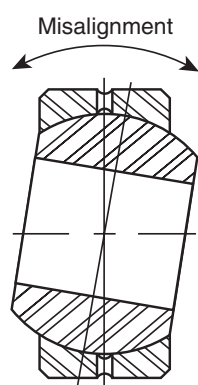

Angular Misalignment

Sealmaster rod ends and spherical plain bearings are primarily selected for their ability to withstand misalignment. As an example, a rod end and a shaft may not always be positioned at right angles and misalignment capability is important. Misalignment can occur through wear, tolerance build-up, structural deflection, or in design. The angle of misalignment in a rod end is controlled by the outside diameter of the head and ball width. The maximum degree of misalignment is obtained when the head contacts the inside of the fork or clevis in which it is mounted. Greater than catalog misalignment can be accomplished by adding a spacer washer between the ball flat and the clevis I.D. or by selecting a rod end with a Y-Stud. The angle of misalignment in a spherical bearing is calculated somewhat differently than a rod end. Illustrated on the following page are common mountings for spherical bearings and the corresponding formula for calculating the angle of misalignment.



Rod Ends and Spherical Plain Bearing Engineering Section

Spherical Plain Bearing Misalignment Capabilities

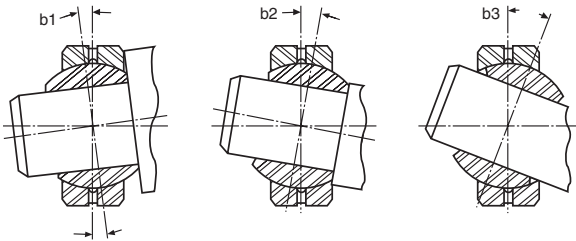

SERIES SBG, SBG-S, SBG-SS, SBG-SA, COM, COR (degrees)			
PART NO.	(+/-) b1	(+/-) b2	(+/-) b3
-3	7 1/2	11 1/2	29 1/2
-4	9	13 1/2	30
-5	8	12	26
-6	7 1/2	10	26 1/2
-7	6 1/2	9 1/2	20 1/2
-8	7	10	20
-10	6 1/2	9	18 1/2
-12	7	9	21
-14	7	9 1/2	16
-16	7	9 1/2	16

SERIES FLBG (degrees)			
PART NO.	(+/-) b1	(+/-) b2	(+/-) b3
-3	9 1/2	16 1/2	34 1/2
-4	8	14 1/2	26
-5	9	14 1/2	30
-6	8	12 1/2	27
-7	6 1/2	11	25
-8	7 1/2	12 1/2	23
-10	7 1/2	12	23
-12	8 1/2	15	27 1/2
-16	6 1/2	10	25

SERIES BH-LS (degrees)			
PART NO.	(+/-) b1	(+/-) b2	(+/-) b3
-16	6 1/2	9	26
-19	6 1/2	8 1/2	25 1/2
-20	6 1/2	8 1/2	23 1/2
-24	6	8	21 1/2
-28	6	8	20
-32	6 1/2	8 1/2	19

SERIES BTS-LS (degrees)			
PART NO.	(+/-) b1	(+/-) b2	(+/-) b3
-12	-	13 1/2	-
-16	-	12	-
-20	-	9 1/2	-
-24	-	7 1/2	-

Rod End Misalignment Capabilities

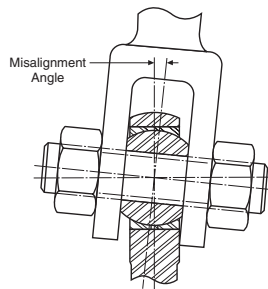

SERIES AR, ARE, ARE-20, TR, TRE, CFF-T, CFM-T, TF, TM, CFF, CFM, CTFD, CTMD (degrees)	
PART NO.	(+/-) a
-3	6 1/2
-4	8
-5	7
-6	6
-7	7
-8	6
-10	8
-12	7
-16	8 1/2

Reference Letters

- B = Bore of Ball
- C = Chamfer on Outer Race
- D = Head or Diameter of Outer Race
- E = Ball Diameter
- H = Housing Width
- $V = \sqrt{(D-2C)^2 + H^2}$
- W = Ball Width



Rod Ends and Spherical Plain Bearing Engineering Section

Common Retention Methods

Clevis mounting is a common practice in securing rod ends in an application. Generally they are assembled into the clevis (or yoke) with a bolt or machined pin.

Clevis Installation

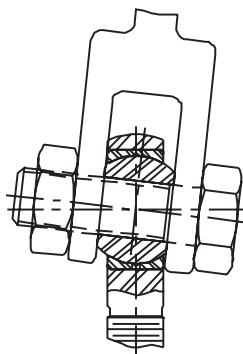

Shoulder on Shaft with Lock Nut

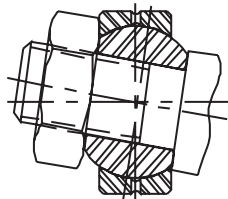

Rod End Grease Fitting Table			
Bore Size	Fitting Number	Thread Size	Hex size
1/4" - 7/16"	#3018 (no ball check)	#6-40 UNF-2A	1/4"
1/2" - 1"	#3016 (no ball check)	#10-32 UNF-2A	1/4"

Lubrication

Sealmaster metal three-piece rod ends are greased from the factory and can be furnished with grease fittings on sizes #4 through #16 to facilitate relubrication in the field. Sealmaster CFF/CFM two-piece rod ends are oil coated and are also available with grease fittings. Sealmaster spherical bearings are oil coated except the stainless steel series which are dry. The BH-LS and BTS-LS series are greased from the factory.

Periodic relubrication helps prevent excessive wear, protects balls and races from corrosion, purges contamination and wear debris and helps to seal against contamination. Relubrication is recommended whenever possible for most applications. The length of interval between greasing is dependent on the application parameters and external conditions. Self-Lubricating PTFE and Delrin* rod ends are generally used where grease relubrication is not practical or desirable. Zerk type threaded grease fittings (designated as "N" suffix) are available on all rod end series except for PTFE and DELRIN. Replacement grease fittings can be ordered by identifying the appropriate rod end series and size.

Caution: Catalog load ratings of rod ends are not applicable when grease fittings are specified, because of the reduced cross section of the head. When selecting rod ends with grease fittings, consult Application Engineering for static load capacities.

* The following trade names, trademarks and/or registered trademarks are used in this material by Regal Power Transmission Solutions are NOT owned or controlled by Regal Power Transmission Solutions and are believed to be owned by the following parties: Delrin; E.I. du Pont de Nemours and Company. Regal Power Transmission Solutions cannot and does not represent or warrant the accuracy of this information.



Rod Ends and Spherical Plain Bearing Engineering Section

Sealmaster spherical plain bearings are manufactured with two lubrication systems which provide a path for lubrication to the ball and race area.

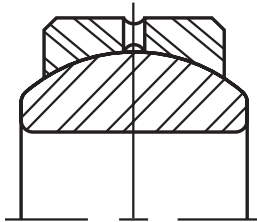

Outer races are manufactured with lubrication grooves and an interconnecting hole in the outer race to direct grease to the ball and race area. Standard on the following series: COM, SBG, SBG-S, SBG-SS, COR, FLBG, HH-LS, BTS-LS

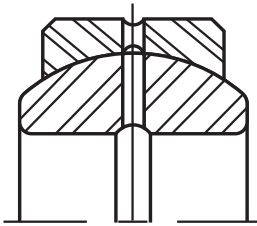

A groove on the ball I.D. and interconnecting hole on "A" series only, directs lubrication from the shaft to the ball and race area. Standard on the SBG-SA

Application

Sealmaster rod ends and spherical plain bearings are designed to provide an efficient smooth transfer of motion in a wide variety of applications and equipment. This motion is usually associated with various types of linkage controls. Commonly referred to as plain or sliding bearings, they are designed primarily to assist and provide motion transfer, support a load, allow for angular motion and angular misalignment. Sealmaster rod ends and spherical bearings serve the industrial market. Typical applications for rod ends and spherical plain bearings can be found in:

- Textile Equipment
- Food Processing
- Bakery Equipment
- Recreational Equipment
- Farm/Garden Machinery
- Bottling Equipment
- Printing Machinery
- Material Handling
- Mining Machinery
- Packaging Machinery
- Labeling Machinery
- Industrial Fans
- Construction Equipment
- Exercise Machines
- Dairy Machinery
- Agricultural Equipment
- Transportation Equipment
- Off-Road Equipment

Rod Ends and Spherical Plain Bearing Engineering Section

Recommended Housing Diameters - Spherical Plain Bearings

Spherical Bearings		Housing Bore (inch)			
Series	Bearing O.D.	Steel Housing		Aluminum Housing	
		Min	Max	Min	Max
SBG, SBG-S, SBG-SS, SBG-SA	+.0000 -.0005				
3	.5625	.5616	.5620	.5614	.5619
4	.6562	.6553	.6557	.6551	.6556
5	.7500	.7491	.7495	.7489	.7494
6	.8125	.8116	.8120	.8114	.8119
7	.9062	.9053	.9057	.9051	.9056
8	1.0000	.9991	.9995	.9989	.9994
10	1.1875	1.1866	1.1870	1.1864	1.1869
12	1.4375	1.4366	1.4370	1.4364	1.4369
14	1.5625	1.5616	1.5620	1.5614	1.5619
16	1.7500	1.7491	1.7495	1.7489	1.7494
FLBG	+.0000 -.0005	Min	Max	Min	Max
3	.6250	.6241	.6245	.6239	.6244
4	.7500	.7491	.7495	.7489	.7494
5	.8750	.8741	.8745	.8739	.8744
6	1.0000	.9991	.9995	.9989	.9994
7	1.1875	1.1865	1.1870	1.1863	1.1869
8	1.3125	1.3115	1.3120	1.3113	1.3119
10	1.5625	1.5613	1.5620	1.5611	1.5619
12	2.2500	2.2488	2.2495	2.2486	2.2494
16	2.3750	2.3738	2.3745	2.3736	2.3744
COM	+.0000 -.0007	Min	Max	Min	Max
3	.5625	.5615	.5619	.5613	.5618
4	.6562	.6552	.6556	.6550	.6555
5	.7500	.7490	.7494	.7488	.7493
6	.8125	.8115	.8119	.8113	.8118
7	.9062	.9052	.9056	.9050	.9055
8	1.0000	.9990	.9994	.9988	.9993
10	1.1875	1.1864	1.1869	1.1862	1.1868
12	1.4375	1.4364	1.4369	1.4362	1.4368
14	1.5625	1.5614	1.5619	1.5612	1.5618
16	1.7500	1.7489	1.7494	1.7487	1.7493

Spherical Bearings		Housing Bore (inch)			
Series	Bearing O.D.	Steel Housing		Aluminum Housing	
		Min	Max	Min	Max
COR	+.0000 -.0005				
3	.5625	.5616	.5620	.5614	.5619
4	.6562	.6553	.6557	.6551	.6556
5	.7500	.7491	.7495	.7489	.7494
6	.8125	.8116	.8120	.8114	.8119
8	1.0000	.9991	.9995	.9989	.9994
10	1.1875	1.1866	1.1870	1.1864	1.1869
12	1.4375	1.4366	1.4370	1.4364	1.4369
14	1.5625	1.5616	1.5620	1.5614	1.5619
16	1.7500	1.7491	1.7495	1.7489	1.7494
BTS-LS	+.0000 -.0007	Min	Max	Min	Max
12	1.5000	1.4988	1.4993	1.4986	1.4992
16	2.2500	2.2488	2.2493	2.2486	2.2492
20	2.3750	2.3738	2.3743	2.3736	2.3742
24	2.7500	2.7488	2.7493	2.7486	2.7492
BH-LS	+.0000 -.0007	Min	Max	Min	Max
16	2.0000	1.9988	1.9993	1.9986	1.9992
19	2.3750	2.3738	2.3743	2.3736	2.3742
20	2.3750	2.3738	2.3743	2.3736	2.3742
24	2.7500	2.7488	2.7493	2.7486	2.7492
28	3.1250	3.1238	3.1243	3.1236	2.1242
32	3.5000	3.4988	3.4993	3.4986	3.4992



Rod Ends and Spherical Plain Bearings

Application Inquiry Worksheet

Company Name	Contact
Address	Phone
	Fax
	Date

I. Application

Currently in use (if current application, what bearings are now being used?)

New _____

Manufacturer _____ Manufacturer's Part No. _____

Your Company's Part No. _____ Application Detail _____

II. Engineering Detail

Rod End 2 pc Steel Race DELRIN Race Spherical Bearing 3 pc Bronze Race TEFLON Liner

Misalignment Angle _____ (Degrees)

Radial Clearance _____ (Min/Max)

Axial Clearance _____ (Min/Max)

Preload Torque (lined rod ends only) _____ Min _____ Max _____

Materials: Ball _____ Race _____ Housing _____

Protective Finish: Ball _____ Race _____ Housing _____

Solid Film Race ID Ball ID Ball & Race ID Grease (specify)

III. Operating Conditions

Radial _____ Lbs.

Axial _____ Lbs.

Type: Reversing Alternating Unidirectional Vibrating Static

Operating Temperature Range _____

Operating Speeds _____

Motion _____ (Degrees/Cycle)

Environmental Conditions: Dry Moisture Corrosive Contamination

Bearing Life Required _____

*Remarks - Specify bearing dimensions on separate sheet or attach part drawing if available.
Fax your application worksheet to: Application Engineering 219-465-2263.*

Customer Signature _____ Date _____

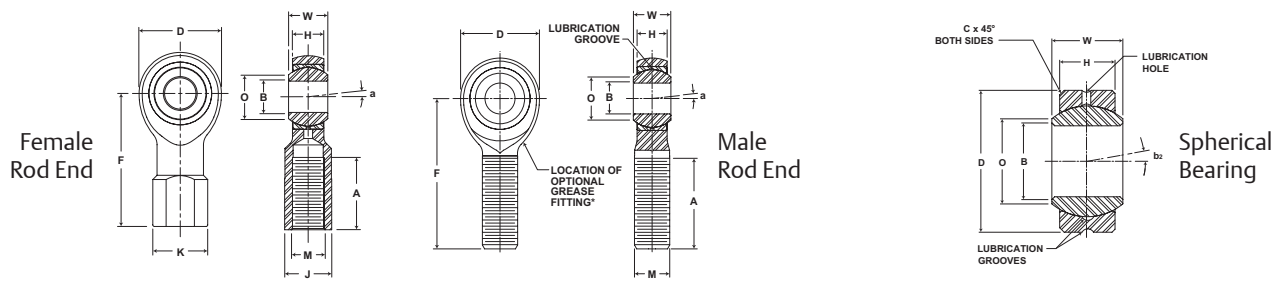

	Bore B	Ball Width W	Housing Width H	Head Dia. D	Length to Ctr. of Ball F	Thread Length A	Thread Size M	Base Dia. K	Across Wrench Flats J	Ball Dia. O	Ball Flat Dia. O	Misalign- ment Angle a	Bore B	Chamfer C Ref	Outside Dia D	Ball Width W	Race Width H	Ball Dia. O	Ball Flat Dia. O	Misalign- ment Angle a	
Male																					
Female																					