

# SEALMASTER®

## ROD ENDS AND SPHERICAL BEARINGS

SEALMASTER Bearings have been providing our customers a broad line of quality rod end and spherical plain bearings for nearly 50 years.

Combining years of innovative bearing design, our engineers have improved materials, construction and manufacturing processes to enhance product performance. Our three piece rod ends with a steel, bronze and Delrin\* races provide a variety of application solutions.

SEALMASTER Bearings has built a solid reputation for high quality, reliable products as well as an outstanding ability to understand and meet the needs of our customers. Our design, manufacturing and technological capabilities are made possible by experienced product engineers and production specialists who are devoted to a single goal - producing the highest quality, most dependable rod ends and spherical bearings possible .... worthy of carrying the SEALMASTER brand name.

SEALMASTER rod ends and spherical bearings are available in a wide variety of designs, bore diameters, thread sizes and materials to meet most industrial application requirements.



As part of our continuing commitment to quality - Statistical Process Control and state-of-the-art equipment is integral to the total manufacturing process to assure the highest quality possible. Our development and testing programs give us constant improvement in design, processes and quality to enable us to better serve your rod end and spherical plain bearing requirements.

# TABLE OF CONTENTS



	Page Number
<b>Introduction</b> .....	144-146
<b>Selection Guide</b> .....	147
<b>Application</b> .....	148-149
<b>Lubrication</b> .....	149
<b>Bearing Nomenclature</b> .....	150
<b>Extra Capacity Precision Series - Rod Ends</b> .....	151-153
AR <i>Three-Piece Female</i> Steel-on-Steel .....	151
ARE <i>Three-Piece Male</i> Steel-on-Steel .....	152
ARE-20 <i>Three-Piece Male</i> Steel-on-Steel .....	153
<b>Precision Series - Rod Ends</b> .....	154-155
TR <i>Three-Piece Female</i> Steel-on-Steel .....	154
TRE <i>Three-Piece Male</i> Steel-on-Steel .....	155
<b>Precision Series - Rod Ends</b> .....	156-157
CFF-T <i>Two-Piece Female</i> Self-Lubricating TEFLON Lined .....	156
CFM-T <i>Two-Piece Male</i> Self-Lubricating TEFLON Lined .....	157
<b>Commercial Series - Rod Ends</b> .....	158-163
TF <i>Three-Piece Female</i> Bronze-on-Steel .....	158
TM <i>Three-Piece Male</i> Bronze-on-Steel .....	159
CFF <i>Two-Piece Female</i> Steel-on-Steel .....	160
CFM <i>Two-Piece Male</i> Steel-on-Steel .....	161
CTFD <i>Three-Piece Female</i> Self-Lubricating DELRIN .....	162
CTMD <i>Three-Piece Male</i> Self-Lubricating DELRIN .....	163
<b>Y - Studs</b> .....	164
<b>Misalignment - Rod Ends and Spherical Bearings</b> .....	165
<b>Precision Series - Spherical Bearings</b> .....	166-167
SBG/SBG-S/SBG-SA/SBG-SS -Metal-to-Metal .....	166
COR Stainless Steel-on-Stainless Steel .....	167
<b>Commercial Series - Spherical Bearings</b> .....	168
COM Steel-on-Steel-Commercial .....	168
<b>Precision Series Spherical Bearings-Special Purpose</b> .....	169
FLBG Bronze-on-Steel .....	169
<b>Precision Series - Heavy Duty Spherical Bearings</b> .....	170-171
BTS-LS Steel-on-Steel Bellows Type Sealed .....	170
BH-LS Steel-on-Steel Heavy Duty .....	171
<b>Engineering/General Information</b> .....	172-173
Recommended Housing Bore Diameters .....	172
Design Modifications .....	173
Application Inquiry Worksheet .....	174-175

## Three-Piece Rod Ends

SEALMASTER three-piece rod ends incorporate a one-piece race formed around a hardened steel chrome plated ball in a controlled manufacturing process. Three-piece construction offers flexibility for alternative race materials designed to help solve specific application problems. Consult our engineering department for material combinations available to meet your application needs.

### Machined Steel Housing

- Increased wrench flat depth on female rod ends to facilitate assembly and installation.

### One-Piece Race

- Improved spherical ball–race conformity for even load distribution.

### Ball

- Alloy steel, heat treated, chrome plated for wear resistance properties.



## Two-Piece Rod Ends

SEALMASTER two-piece design rod ends consist of a machined housing formed around a hardened steel chrome plated ball. This construction offers more load capacity than three-piece design with like housing materials because of greater housing cross section.

### Machined Steel Housing

- Increased wrench flat depth on female rod ends to facilitate assembly and installation.

### Ball

- Alloy steel, heat treated, chrome plated for wear resistance properties.



## Two Types of Self-Lubricating Rod End Designs Are Offered.



**Two-Piece TEFLON Rod Ends...** combine the strength of two-piece design and self-lubricating TEFLON liner for use in a wide variety of industrial applications.

**DELRIN Rod Ends...** for light duty applications where relubrication should be avoided.

# TYPE, SIZES, AVAILABILITY, SELECTION FACTORS

## Selection Guide

The tables below are intended as a guide to help choose the rod end or spherical plain bearing best suited for the application. Careful consideration should be given when selecting rod ends and spherical bearings. For special rod end or spherical bearing requirements – See Application Data Worksheet on pages 174-175. We recommend the product be tested to be sure it meets minimum application requirements. Contact our engineering department for application assistance.

### Other important factors that should be considered are:

- Duty cycle
- Speed (surface velocity in FPM)
- Oscillating angle
- Installation requirements, retention methods, housing and shaft fits
- Allowable wear
- Environmental conditions

### Rod Ends

Series	Pages	Bore Size	Max Static Load Capacity (lbs)	Construction	Race Material	Static Load	Reversing Load	Shock Load	Maximum Temp.	Grease Fitting Available	Y-Stud	Self-Lubricating	Relative Price Index ▲
AR/ARE/ARE-20	151-153	3/16-3/4"	2,850 – 23,200	3 Pc.	Steel	***	***	***	350 F	Y	N/A	N	2.0
TR/TRE	154-155	3/16-1"	900 – 21,000	3 Pc.	Steel	**	***	***	350 F	Y	Y	N	1.0
CFF-T/CFM-T	156-157	3/16-1"	865 – 21,000	2 Pc.	TEFLON Liner	**	**	**	250 F	N/A	Y	Y	1.7
TF/TM	158-159	3/16-3/4"	900 – 11,300	3 Pc.	Bronze	**	**	**	350 F	Y	Y	N	0.8
CFF/CFM	160-161	3/16-1"	950 – 25,200	2 Pc.	Steel	**	**	**	350 F	Y	Y	N	0.7
CTFD/CTMD	162-163	3/16-3/4"	800 – 6,600	3 Pc.	DELTRIN	*	*	*	150 F	N/A	Y	Y	0.8

### Spherical Bearings

Series	Page	Bore Size	Max Static Load Capacity (lbs)	Construction	Race Material	Static Load	Reversing Load	Shock Load	Maximum Temp.	Relative Price Index
SBG	166	3/16-1"	2,750 – 52,000	2 Pc.	Bronze	**	**	**	350 F	1.0
SBG-S	166	3/16-1"	6,480 – 125,000	2 Pc.	H.T. Steel	***	***	***	350 F	0.8
SBG-SA	166	1/2-1"	26,900 – 125,000	2 Pc.	H.T. Steel	***	***	***	350 F	0.9
SBG-SS	166	3/16-1"	4,400 – 83,000	2 Pc.	Stainless Steel	**	**	**	500 F	1.0
COR	167	3/16-1"	4,800 – 93,500	2 Pc.	Stainless Steel, Heat Treated	***	***	***	500 F	1.4
COM	168	3/16-1"	3,250 – 54,700	2 Pc.	Steel	**	**	**	350 F	0.5
FLBG	169	3/16-1"	2,960 – 48,200	3 Pc.	Bronze	**	**	**	350 F	1.5
BTS-LS	170	3/4-1 1/2"	31,500 – 130,000	2 Pc.	Steel	***	***	***	350 F	2.3
BH-LS	171	1-2"	69,500 – 221,000	2 Pc.	Steel	***	***	***	350 F	1.6

\*Good      \*\*Better      \*\*\*Best

▲ -For Estimating Purposes Only — Individual Sizes Will Vary; Subject to Change Without Notification

## Application

SEALMASTER rod ends and spherical plain bearings are designed to provide an efficient smooth transfer of motion in a wide variety of applications and equipment. This motion is usually associated with various types of linkage controls. Commonly referred to as plain or sliding bearings, they are designed primarily to assist and provide motion transfer, support a load, allow for angular motion and angular misalignment.

SEALMASTER rod ends and spherical bearings serve the industrial market. Typical applications for rod ends and spherical plain bearings can be found in:

- Textile Equipment
- Packaging Machinery
- Food Processing
- Labeling Machinery
- Bakery Equipment
- Industrial Fans
- Recreational Equipment
- Construction Equipment
- Farm/Garden Machinery
- Exercise Machines
- Bottling Equipment
- Dairy Machinery
- Printing Machinery
- Agricultural Equipment
- Material Handling
- Transportation Equipment
- Mining Machinery
- Off-Road Equipment

SEALMASTER rod ends can be joined together or connected with a threaded rod or tube to form linkage assemblies allowing design engineers flexibility in transferring motion between points with long center distances.

Normal operation of rod ends results in wear of the raceways or fatigue or fracture of the outer member. Give consideration to this in the design of the equipment.

Spherical plain bearings provide a similar function as rod ends and must be supported in a housing. Spherical bearings afford customers greater load rating per equivalent rod end bore size. This occurs because rod end load capacity is controlled by the head and shank geometry. Spherical bearings have a larger bearing area and generally are less restricted by the housing material or dimensions in which they are mounted.

## Load Ratings

### Rod Ends

*Static radial load ratings* are applied perpendicular to the bearing ball bore and are a function of strength of race and housing materials. SEALMASTER static load ratings listed in this catalog are maximum working loads and factors of safety should be applied as necessary. External conditions including mounting components, bolts, pins and housings should be considered separately when designing this product into an application.

*Static axial load ratings* are applied parallel or through the bearing ball bore. In general, rod ends are not intended to carry axial loads. Applications of rod ends with axial loading should be reviewed with engineering.

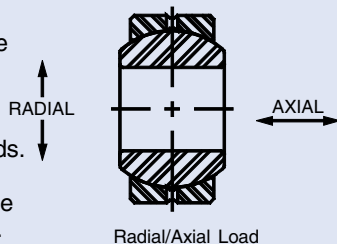

### Spherical Bearings

*Static radial load ratings* listed in the catalog are based on a maximum permanent set in the bearing race of .2% of normal ball diameter.

*Static axial load ratings* are approximately 20% of the radial static load ratings listed with each unit. Caution should be exercised in designing adequate housings to support spherical bearings.

### Angular Misalignment

SEALMASTER rod ends and spherical bearings are primarily selected for their ability to withstand misalignment. As an example, a rod end and a shaft may not always be positioned at right angles and misalignment capability is important. Misalignment can occur through wear, tolerance build-up, structural deflection, or in design. For more information on misalignment, refer to page 165 in this catalog.

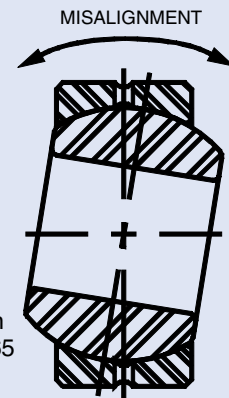

### Common Retention Methods

Clevis mounting is a common practice in securing rod ends in an application. Generally they are assembled into the clevis (or yoke) with a bolt or machined pin.

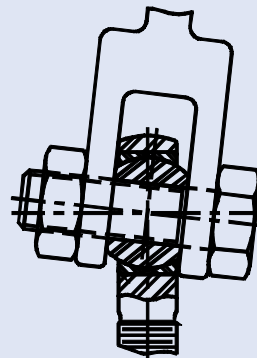

Clevis Installation

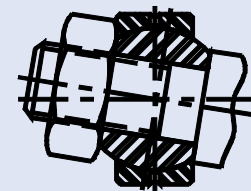

Shoulder on Shaft with lock nut



# APPLICATION, LOAD RATINGS, LUBRICATION

## Lubrication

SEALMASTER metal three-piece rod ends are greased from the factory and can be furnished with grease fittings on sizes #4 through #16 to facilitate relubrication in the field. SEALMASTER CFF/CFM two-piece rod ends are oil coated and are also available with grease fittings. SEALMASTER spherical bearings are oil coated except the stainless steel series which are dry. The BH-LS and BTS-LS Series are greased from the factory. Periodic relubrication helps prevent excessive wear, protects balls and races from corrosion, purges contamination and wear debris and helps to seal against contamination. Relubrication is recommended whenever possible for most applications. The length of interval between greasing is dependent on the application parameters and external conditions. Self-Lubricating TEFLON and DELRIN rod ends are generally used where grease relubrication is not practical or desirable.

Zerk type threaded grease fittings (designated as "N" suffix) are available on all rod end series except for TEFLON and DELRIN. Replacement grease fittings can be ordered by identifying the appropriate rod end series and size.

**Caution:** Catalog load ratings of rod ends are not applicable when grease fittings are specified, because of the reduced cross section of the head. When selecting rod ends with grease fittings, consult our engineering department for static load capacities.

Rod ends with flush type grease fittings (designated as "FN" suffix) are available on special order. (See page 173.)

SEALMASTER spherical bearings are manufactured with two lubrication systems which provide a path for lubrication to the ball and race area.

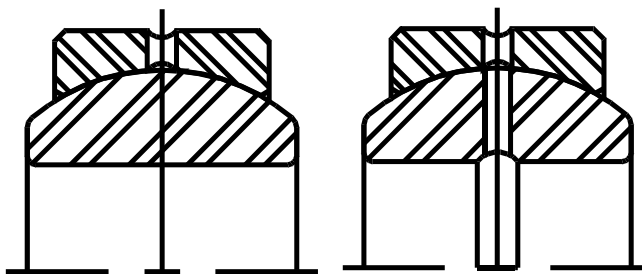

Outer races are manufactured with lubrication grooves and an interconnecting hole in the outer race to direct grease to the ball and race area.

A groove on the ball I.D. and interconnecting hole on "A" series only, directs lubrication from the shaft to the ball and race area.

Standard on the following series:

COM	SBG-SS	BH-LS
SBG	COR	BTS-LS
SBG-S	FLBG	

Standard on the SBG-SA sizes #8-16 only

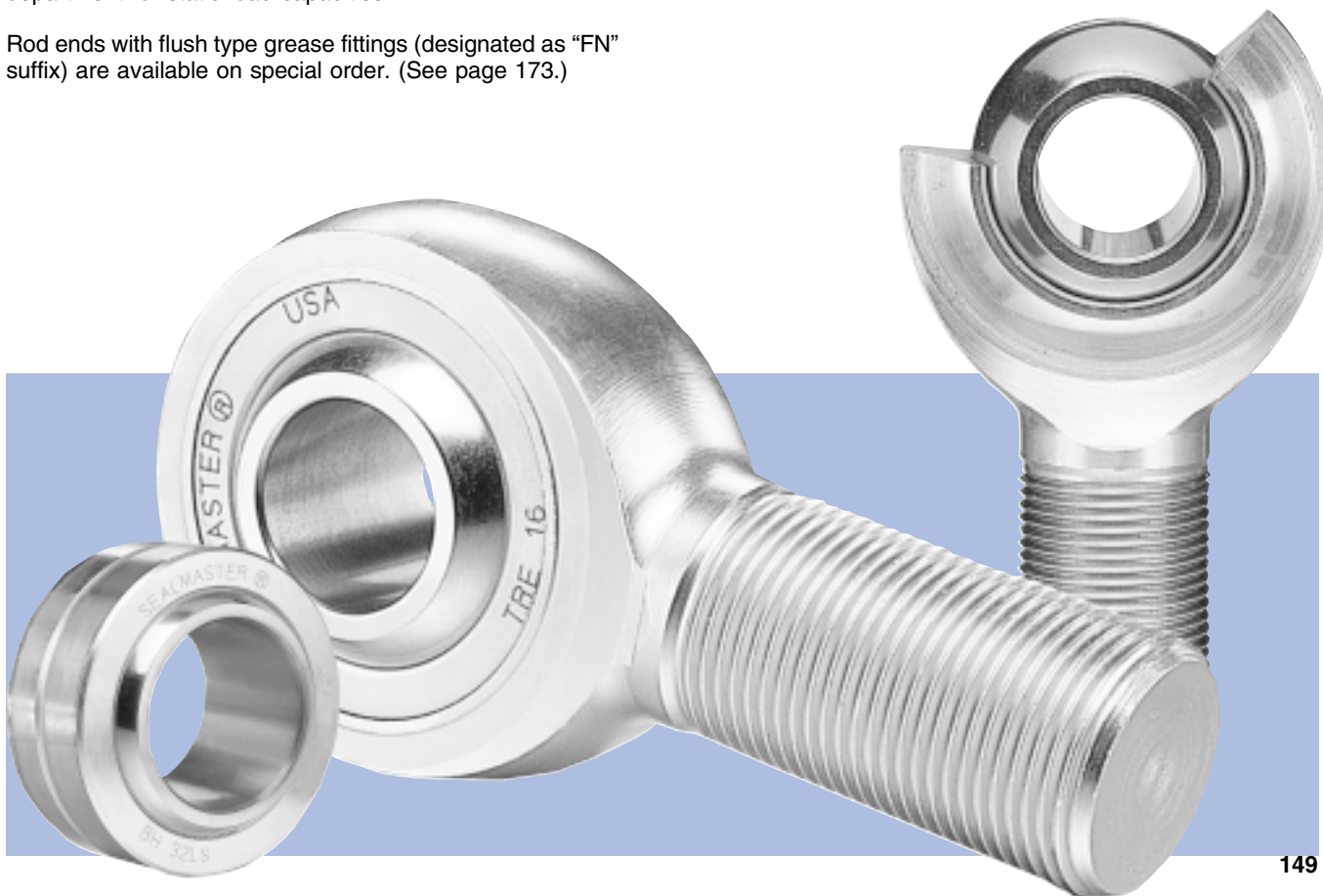

# SEALMASTER® ROD ENDS & SPHERICAL BEARINGS

## NOMENCLATURE - ROD ENDS

SEALMASTER rod end part number descriptions are called out as follows:

### TYPE OR SERIES

AR, ARE  
TR, TRE  
CFF-T, CFM-T  
TF, TM  
CFF, CFM  
CTFD, CTMD

### SIZE NUMBER

Bore size in increments of one-sixteenth (1/16) inches

### SUFFIX FOR FEATURE

(May or may not be found on all units)

20 - Large Shank  
N - Grease Fitting  
T - TEFLON Liner  
Y - Y-Stud  
# - MTO Special Designation  
R - Reverse Fitting Location with Y-Stud

### PRECISION ROD ENDS

Example: AREL-8-20N

A - Alloy Steel Outer Member  
R - Rod End  
E - External (Male) Thread  
L - Left Hand Thread  
8 - 8/16" or 1/2" Ball Bore  
20 - Large Shank (5/8")  
N - Grease Fitting

Example: TRE-8YN

T - Three-Piece  
R - Rod End  
E - External (Male) Thread  
8 - 8/16" or 1/2" Ball Bore & Thread Size  
Y - Y-Stud  
N - Grease Fitting

Example: AR-8N

A - Alloy Steel Outer Member  
R - Rod End  
8 - 8/16" or 1/2" Ball Bore & Thread Size  
N - Grease Fitting

### COMMERCIAL ROD ENDS

Example: TF-10N

T - Three-Piece  
F - Female (Internal) Thread  
10 - 10/16" or 5/8" Ball Bore & Thread Size

N - Grease Fitting

Example: CFF-6N

C - Commercial Series  
F - Female (Internal) Thread

6 - 6/16" or 3/8" Ball Bore & Thread Size

N - Grease Fitting

Example: CTMD-4

C - Commercial Series  
T - Three-Piece

M - Male  
D - DELRIN Race  
4 - 4/16" or 1/4" Ball Bore & Thread Size

## NOMENCLATURE - SPHERICAL BEARINGS

SEALMASTER spherical bearing catalog part number descriptions are called out as follows:

### TYPE OR SERIES

SBG  
COM  
COR  
BTS  
BH  
FLBG

### SIZE NUMBER

Bore size in increments of one-sixteenth (1/16) inches

### SUFFIX FOR FEATURE

(May or may not be found on all units)

S - 4130 H.T. Steel Race  
SS - Stainless Steel Race and Ball  
A - Groove on Ball I.D. and Interconnecting Hole  
LS - Low Carbon Steel Race  
# - MTO Special Designation

### PRECISION SPHERICAL BEARINGS

Example: SBG-14

S - Spherical  
B - Bearing  
G - Grooved (Race O.D.)  
14 - 14/16" or 7/8" Ball Bore

Example: SBG-16S

S - Spherical  
B - Bearing  
G - Grooved (Race O.D.)  
16 - 16/16" or 1" Ball Bore  
S - 4130 H.T. Steel Race

Example: SBG-5SS

S - Spherical  
B - Bearing  
G - Grooved (Race O.D.)  
5 - 5/16" Ball Bore  
SS - Stainless Steel Race and Ball

Example: COR-12

C - Corrosion Series  
O - CORrosion Series  
R - 12 - 12/16" or 3/4" Ball Bore

Example: BTS-20LS

B - Bellows  
T - Type  
S - Seal  
2 - 20 - 20/16" or 1 1/4" Ball Bore  
LS - Low Carbon Steel Race

Example: BH-32LS

B - Bearing  
H - Heavy Duty  
32 - 32/16" or 2" Ball Bore  
LS - Low Carbon Steel Race

### COMMERCIAL SPHERICAL BEARINGS

Example: COM-3

C - Commercial Series  
O - COMmercial Series  
M - 3 - 3/16" Ball Bore

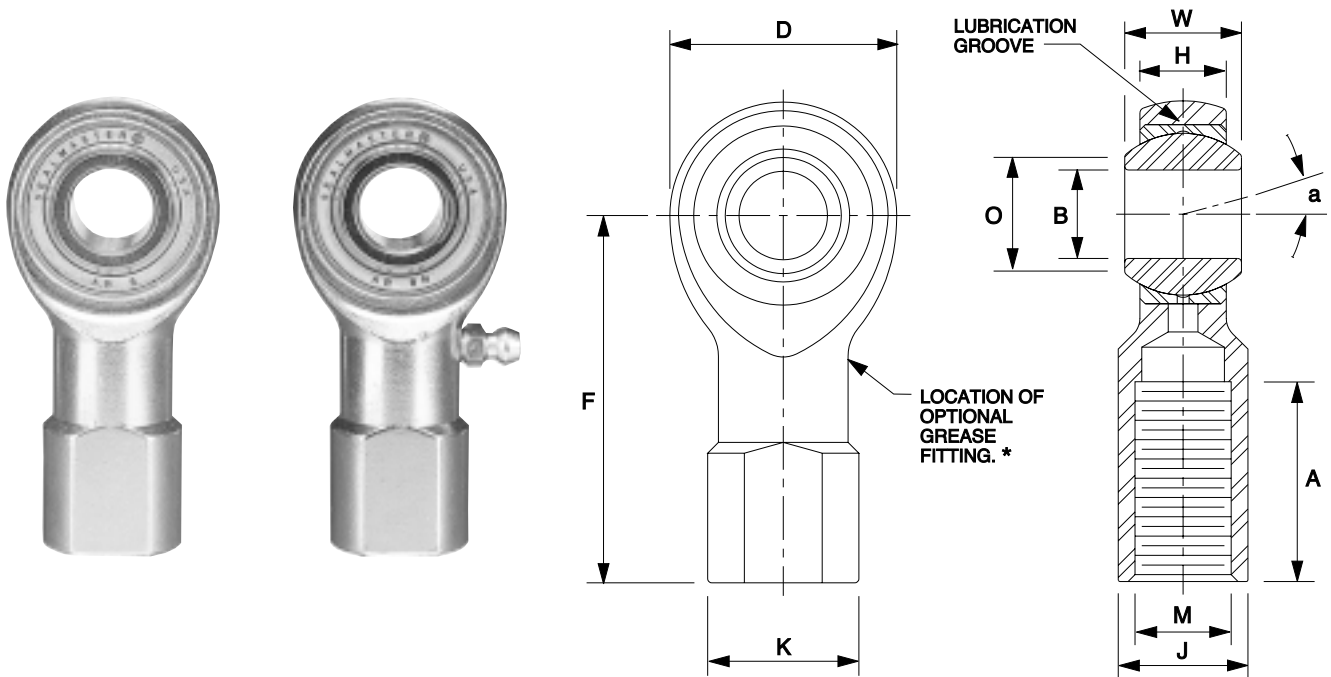

## AR,AR-N Series Three-Piece Precision Extra Capacity Female Rod Ends

PART NUMBER	BORE B +.0015 -.0005	BALL WIDTH W +.000 -.005	HOUSING WIDTH H +.005 -.005	HEAD DIA. D +.010 -.010	LENGTH TO CTR. OF BALL F +.010 -.010	THREAD LENGTH A MIN.	THREAD SIZE M CLASS UNF-3B	BASE DIA. K REF.	ACROSS WRENCH FLATS J +.010 -.010	BALL DIA. REF.	BALL FLAT DIA. O REF.	MAX. STATIC RADIAL LOAD LBS.	MIS-ALIGNMENT ANGLE a DEG. +/-	APPROX. WEIGHT LBS.
AR-3	.1900	.312	.250	.625	1.062	.531	#10-32	.375	.312	.437	.306	3,700	6½	.03
AR-4	.2500	.375	.281	.750	1.312	.719	¼-28	.469	.375	.500	.331	5,370	8	.06
AR-5	.3125	.437	.344	.875	1.375	.719	⅜-24	.531	.437	.625	.447	7,500	7	.08
AR-6	.3750	.500	.406	1.000	1.625	.906	⅝-24	.688	.562	.718	.517	9,570	6	.14
AR-7	.4375	.562	.437	1.125	1.812	1.031	7/16-20	.750	.625	.812	.586	11,000	7	.18
AR-8	.5000	.625	.500	1.312	2.125	1.156	½-20	.875	.750	.937	.698	13,500	6	.29
AR-10	.6250	.750	.562	1.500	2.500	1.469	⅝-18	1.000	.875	1.125	.839	17,300	8	.43
AR-12	.7500	.875	.687	1.750	2.875	1.719	¾-16	1.125	1.000	1.312	.978	23,200	7	.64

AR and AR-N series extra capacity female rod ends are manufactured with an alloy steel heat treated outer member to produce higher static load ratings. This series is intended for heavier duty applications such as linkages on hoists and cranes or on the ends of hydraulic cylinder connectors.

### MATERIAL SPECIFICATIONS

**OUTER MEMBER** - 4130 Alloy steel, heat treated, with protective plating for corrosion resistance  
**RACE** - Carbon steel with protective plating for corrosion resistance  
**BALL** - Alloy steel, heat treated, chrome plated

### NOTES

- \*1. Rod ends with Zerk type grease fittings can be obtained by ordering the AR-N series; Example: AR-8N.
- Grease fittings are available on sizes 4 through 12 only.
- Optional flush type fittings are available on special order by adding "FN" suffix to the part numbers; Example: AR-8FN.
- Load ratings apply to the AR series only. For AR-N load ratings contact engineering.
- This series is magnetic particle inspected upon request only.
- To order left hand threaded units add letter "L" to part number prefix; Example: ARL-8.
- For design modifications, see page 173.



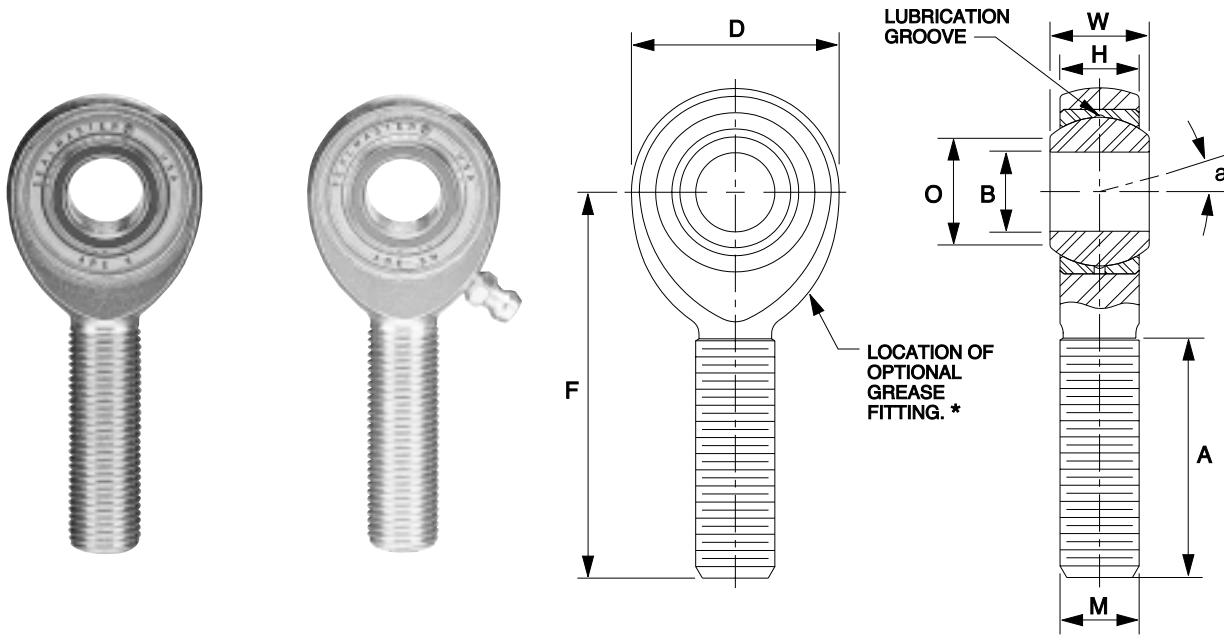

## ARE, ARE-N Series Three-Piece Precision Extra Capacity Male Rod Ends

PART NUMBER	BORE B +.0015 -.0005	BALL WIDTH W +.000 -.005	HOUSING WIDTH H +.005 -.005	HEAD DIA. D +.010 -.010	LENGTH TO CTR. OF BALL F +.010 -.010	THREAD LENGTH A MIN.	THREAD SIZE M CLASS UNF-3A	BALL DIA. REF.	BALL FLAT DIA. O REF.	MAX. STATIC RADIAL LOAD LBS.	MIS-ALIGNMENT ANGLE a DEG. +/-	APPROX. WEIGHT LBS.
ARE-3	.1900	.312	.250	.625	1.250	.719	#10-32	.437	.306	2,850	6½	.03
ARE-4	.2500	.375	.281	.750	1.562	.969	¼-28	.500	.331	4,480	8	.05
ARE-5	.3125	.437	.344	.875	1.875	1.219	5/16-24	.625	.447	7,280	7	.08
ARE-6	.3750	.500	.406	1.000	1.938	1.219	3/8-24	.718	.517	9,580	6	.12
ARE-7	.4375	.562	.437	1.125	2.125	1.344	7/16-20	.812	.586	11,000	7	.17
ARE-8	.5000	.625	.500	1.312	2.438	1.469	½-20	.937	.698	13,500	6	.26
ARE-10	.6250	.750	.562	1.500	2.625	1.594	5/8-18	1.125	.839	17,300	8	.41
ARE-12	.7500	.875	.687	1.750	2.875	1.719	¾-16	1.312	.978	23,200	7	.64

ARE and ARE-N extra capacity male rod ends are manufactured with an alloy steel heat treated outer member to produce higher static load ratings. This series is intended for heavier duty applications such as linkages on hoists and cranes or on hydraulic cylinder connectors.

### MATERIAL SPECIFICATIONS

**OUTER MEMBER - 4130 Alloy steel, heat treated, with protective plating for corrosion resistance**

**RACE - Carbon steel with protective plating for corrosion resistance**

**BALL - Alloy steel, heat treated, chrome plated**

### NOTES

- \*1. Rod ends with Zerk type grease fittings can be obtained by ordering the ARE-N series; Example: ARE-8N.
2. Grease fittings are available on sizes 4 through 12 only.
3. Optional flush type fittings are available on special order by adding "FN" suffix to the part numbers; Example: ARE-8FN.
4. Load ratings apply to the ARE series only. For ARE-N load ratings contact engineering.
5. This series is magnetic particle inspected upon request only.
6. To order left hand threaded units add letter "L" to part number prefix; Example: AREL-8.
7. For design modifications, see page 173.

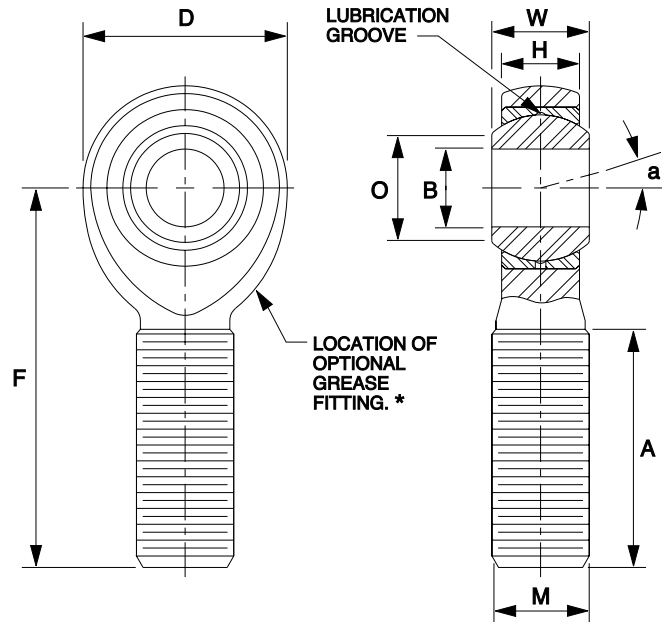

## ARE-20, ARE-20N Series Three-Piece Precision Extra Capacity Male Rod Ends

PART NUMBER	BORE B +.0015 -.0005	BALL WIDTH W +.000 -.005	HOUSING WIDTH H +.005 -.005	HEAD DIA. D +.010 -.010	LENGTH TO CTR. OF BALL F +.010 -.010	THREAD LENGTH A MIN.	THREAD SIZE M CLASS UNF-3A	BALL DIA. REF.	BALL FLAT DIA. O REF.	MAX. STATIC RADIAL LOAD LBS.	MIS-ALIGNMENT ANGLE a DEG. +/-	APPROX. WEIGHT LBS.
ARE-3-20	.1900	.312	.250	.625	1.250	.719	1/4-28	.437	.306	3,700	6 1/2	.03
ARE-4-20	.2500	.375	.281	.750	1.562	.969	5/16-24	.500	.331	5,370	8	.06
ARE-5-20	.3125	.437	.344	.875	1.875	1.219	3/8-24	.625	.447	7,500	7	.09
ARE-6-20	.3750	.500	.406	1.000	1.938	1.219	7/16-20	.718	.517	9,570	6	.13
ARE-7-20	.4375	.562	.437	1.125	2.125	1.344	1/2-20	.812	.586	11,000	7	.18
ARE-8-20	.5000	.625	.500	1.312	2.438	1.469	5/8-18	.937	.698	13,500	6	.30
ARE-10-20	.6250	.750	.562	1.500	2.625	1.594	3/4-16	1.125	.839	17,300	8	.46
ARE-12-20	.7500	.875	.687	1.750	2.875	1.719	7/8-14	1.312	.978	23,200	7	.72

ARE-20 and ARE-20N extra capacity male rod ends are manufactured with an alloy steel heat treated outer member to produce higher static load ratings. This series has oversize shanks (larger threads compared to the bore size) for additional shank strength. This series is intended for heavier duty applications such as linkages on hoists and cranes or on hydraulic cylinder connectors.

### MATERIAL SPECIFICATIONS

**OUTER MEMBER** - 4130 Alloy steel, heat treated, with protective plating for corrosion resistance  
**RACE** - Carbon steel with protective plating for corrosion resistance  
**BALL** - Alloy steel, heat treated, chrome plated

### NOTES

- \*1. Rod ends with Zerk type grease fittings can be obtained by ordering the ARE-20N series; Example: ARE-8-20N.
- Grease fittings are available on sizes 4 through 12 only.
- Optional flush type fittings are available on special order by adding "FN" suffix to the part numbers; Example: ARE-8-20FN.
- Load ratings apply to the ARE-20 series only. For ARE-20N load ratings contact engineering.
- This series is magnetic particle inspected upon request only.
- To order left hand threaded units add letter "L" to part number prefix; Example: AREL-8-20.
- For design modifications, see page 173.

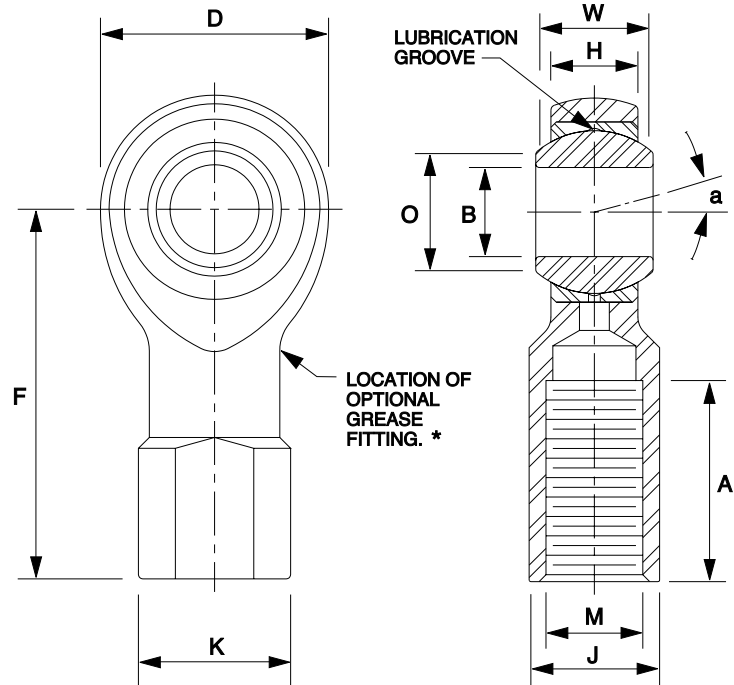

## TR, TR-N Series Three-Piece Precision Female Rod Ends

PART NUMBER	BORE B +.0015 -.0005	BALL WIDTH W +.000 -.005	HOUSING WIDTH H +.005 -.005	HEAD DIA. D +.010 -.010	LENGTH TO CTR. OF BALL F +.015 -.015	THREAD LENGTH A MIN.	THREAD SIZE M CLASS UNF-2B	BASE DIA. K REF.	ACROSS WRENCH FLATS J +.010 -.010	BALL DIA. REF.	BALL FLAT DIA. O REF.	MAX. STATIC RADIAL LOAD LBS.	MIS-ALIGNMENT ANGLE a DEG. +/-	APPROX. WEIGHT LBS.
TR-3	.1900	.312	.250	.625	1.062	.531	#10-32	.375	.312	.437	.306	1,850	6½	.03
TR-4	.2500	.375	.281	.750	1.312	.719	¼-28	.469	.375	.500	.331	2,700	8	.06
TR-5	.3125	.437	.344	.875	1.375	.719	5/16-24	.531	.437	.625	.447	3,350	7	.08
TR-6	.3750	.500	.406	1.000	1.625	.906	3/8-24	.688	.562	.718	.517	4,450	6	.14
TR-7	.4375	.562	.437	1.125	1.812	1.031	7/16-20	.750	.625	.812	.586	5,350	7	.18
TR-8	.5000	.625	.500	1.312	2.125	1.156	½-20	.875	.750	.937	.698	7,400	6	.29
TR-10	.6250	.750	.562	1.500	2.500	1.469	5/8-18	1.000	.875	1.125	.839	8,050	8	.43
TR-12	.7500	.875	.687	1.750	2.875	1.719	¾-16	1.125	1.000	1.312	.978	11,300	7	.64
**TR-16	1.0000	1.375	1.000	2.750	4.125	2.094	1 ¼-12	1.688	1.500	1.875	1.269	21,000	8½	2.25

TR and TR-N precision series female rod ends are a popular choice for general industrial applications, including control linkages in packaging, printing, material handling, actuators and bag closures, etc.

### MATERIAL SPECIFICATIONS

**OUTER MEMBER - Carbon steel with protective plating for corrosion resistance**  
**RACE - Carbon steel with protective plating for corrosion resistance**  
**BALL - Alloy steel, heat treated, chrome plated**

### NOTES

- \* 1. Rod ends with Zerk type grease fittings can be obtained by ordering the TR-N series; Example: TR-8N.
2. Grease fittings are available on sizes 4 through 16 only.
3. Optional flush type fittings are available on special order by adding "FN" suffix to the part numbers; Example: TR-8FN.
4. Load ratings apply to the TR series only. For TR-N load ratings contact engineering.
5. To order left hand threaded units add letter "L" to part number prefix; Example: TRL-8.
6. Add letter "Y" to the part number suffix to indicate stud. Example: TR-8Y.
7. For design modifications, see page 173.
- \*\* 8. Tolerances for "D" Dimension is +.030, -.010. For "H" Dimension is +.030, -.010.

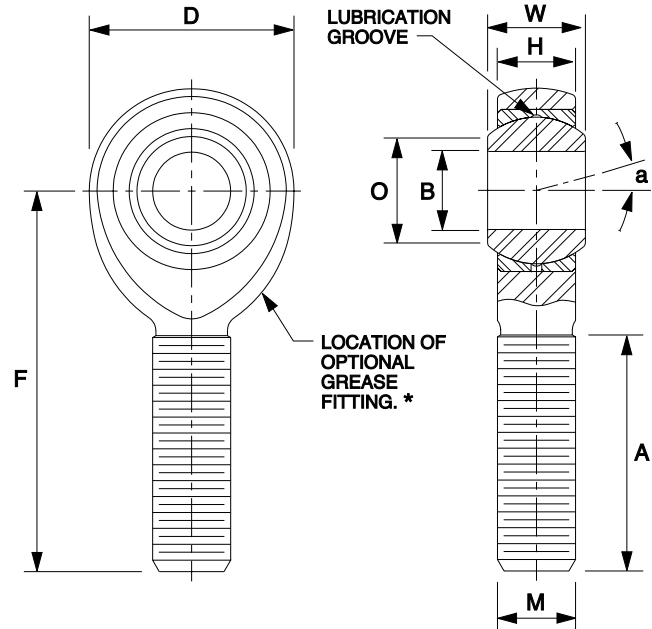

## TRE, TRE-N Series Three-Piece Precision Male Rod Ends

PART NUMBER	BORE B +.0015 -.0005	BALL WIDTH W +.000 -.005	HOUSING WIDTH H +.005 -.005	HEAD DIA. D +.010 -.010	LENGTH TO CTR. OF BALL F +.015 -.015	THREAD LENGTH A MIN.	THREAD SIZE M CLASS UNF-3A	BALL DIA. REF.	BALL FLAT DIA. O REF.	MAX. STATIC RADIAL LOAD LBS.	MIS-ALIGNMENT ANGLE a DEG. +/-	APPROX. WEIGHT LBS.
TRE-3	.1900	.312	.250	.625	1.250	.719	#10-32	.437	.306	900	6 1/2	.03
TRE-4	.2500	.375	.281	.750	1.562	.969	1/4-28	.500	.331	1,700	8	.05
TRE-5	.3125	.437	.344	.875	1.875	1.219	5/16-24	.625	.447	2,500	7	.08
TRE-6	.3750	.500	.406	1.000	1.938	1.219	3/8-24	.718	.517	4,000	6	.12
TRE-7	.4375	.562	.437	1.125	2.125	1.344	7/16-20	.812	.586	5,000	7	.17
TRE-8	.5000	.625	.500	1.312	2.438	1.469	1/2-20	.937	.698	7,000	6	.26
TRE-10	.6250	.750	.562	1.500	2.625	1.594	5/8-18	1.125	.839	8,050	8	.41
TRE-12	.7500	.875	.687	1.750	2.875	1.719	3/4-16	1.312	.978	11,300	7	.64
** TRE-16	1.0000	1.375	1.000	2.750	4.125	2.094	1 1/4-12	1.875	1.269	21,000	8 1/2	2.25

TRE and TRE-N precision series male rod ends are a popular choice for general industrial applications, including control linkages in packaging, printing, material handling, actuators and bag closures, etc.

### MATERIAL SPECIFICATIONS

**OUTER MEMBER** - Carbon steel with protective plating for corrosion resistance  
**RACE** - Carbon steel with protective plating for corrosion resistance  
**BALL** - Alloy steel, heat treated, chrome plated

### NOTES

- \* 1. Rod ends with Zerk type grease fittings can be obtained by ordering the TRE-N series; Example: TRE-8N.
2. Grease fittings are available on sizes 4 through 16 only.
3. Optional flush type fittings are available on special order by adding "FN" suffix to the part numbers; Example: TRE-8FN.
4. Load ratings apply to the TRE series only. For TRE-N load ratings contact engineering.
5. To order left hand threaded units add letter "L" to part number prefix; Example: TREL-8.
6. Add letter "Y" to the part number suffix to indicate stud; Example: TRE-8Y.
7. For design modifications, see page 173.
- \*\* 8. Tolerances for "D" Dimension is +.030, -.010. For "H" Dimension is +.030, -.010.

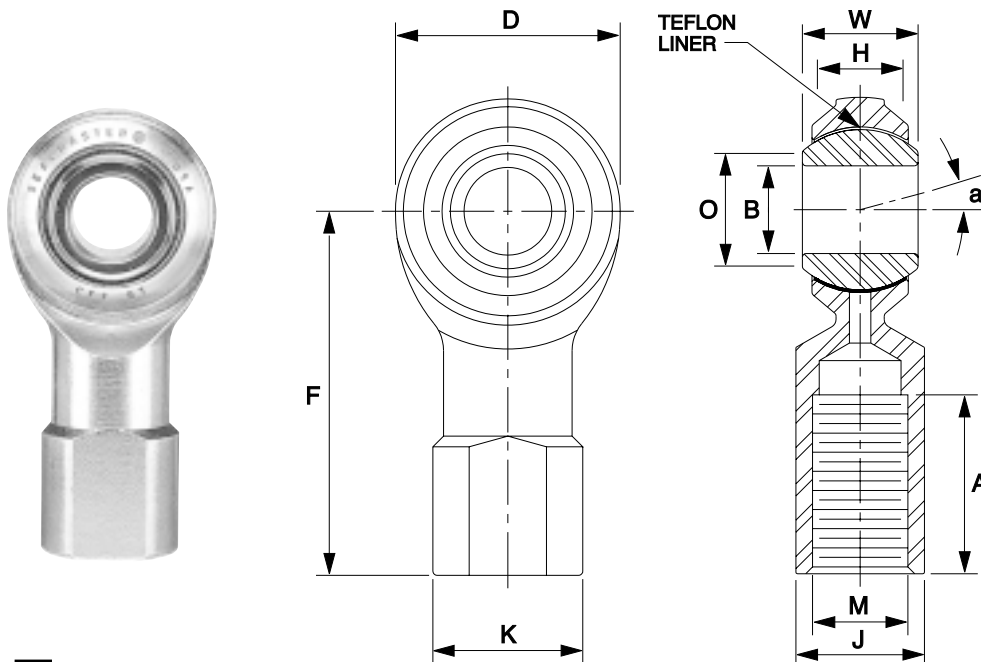

## CFF-T Series Two-Piece Precision Female Rod Ends - Self Lubricating Teflon Lined

PART NUMBER	BORE B +.0015 -.0005	BALL WIDTH W +.000 -.005	HOUSING WIDTH H REF.	HEAD DIA. D +.031 -.031	LENGTH TO CTR. OF BALL F +.015 -.015	THREAD LENGTH A MIN.	THREAD SIZE M CLASS UNF-2B	BASE DIA. K REF.	ACROSS WRENCH FLATS J +.010 -.010	BALL DIA. O REF.	BALL FLAT DIA. O REF.	MAX. STATIC RADIAL LOAD LBS.	MIS-ALIGNMENT ANGLE a DEG. +/-	APPROX. WEIGHT LBS.
CFF-3T	.1900	.312	.250	.625	1.062	.469	#10-32	.375	.312	.437	.306	865	6 1/2	.03
CFF-4T	.2500	.375	.281	.750	1.312	.656	1/4-28	.469	.375	.500	.331	1,550	8	.06
CFF-5T	.3125	.437	.344	.875	1.375	.656	5/16-24	.531	.437	.625	.447	2,080	7	.08
CFF-6T	.3750	.500	.406	1.000	1.625	.781	3/8-24	.688	.562	.718	.517	2,950	6	.14
CFF-7T	.4375	.562	.437	1.125	1.812	.906	7/16-20	.750	.625	.812	.586	3,160	7	.18
CFF-8T	.5000	.625	.500	1.312	2.125	1.031	1/2-20	.875	.750	.937	.698	4,920	6	.29
CFF-10T	.6250	.750	.562	1.500	2.500	1.344	5/8-18	1.000	.875	1.125	.839	5,460	8	.43
CFF-12T	.7500	.875	.687	1.750	2.875	1.531	3/4-16	1.125	1.000	1.312	.978	8,300	7	.64
CFF-16T	1.0000	1.375	1.000	2.750	4.125	2.000	1 1/4-12	1.688	1.500	1.875	1.269	21,000	8 1/2	2.25

CFF-T precision series female rod ends combine the strength of two-piece design and self-lubricating TEFLON for use in a wide variety of applications. These self-lubricating rod ends are used where grease relubrication is not practical or desirable and operate to 250 degrees F in normal industrial applications. A hardened steel chrome plated ball moving against a TEFLON fabric liner results in smooth operation and longer wear when compared with most metal-metal units. CFF-T rod ends are manufactured with consistent no load rotational torque values making them a popular choice in carton folding, book binding, and printing equipment applications, etc., where close tolerances and accurate linkage control are important.

### MATERIAL SPECIFICATIONS

**OUTER MEMBER** - Carbon steel with protective plating for corrosion resistance  
**BALL** - Alloy steel, heat treated, chrome plated  
**LINER** - Teflon fabric

### NOTES

1. To order left hand threaded units add letter "L" to part number prefix; Example: CFFL-8T.
2. "T" in part number prefix indicates TEFLON liner.
3. Add letter "Y" to the part number suffix to indicate stud; Example: CFF-8TY.
4. For design modifications, see page 173.



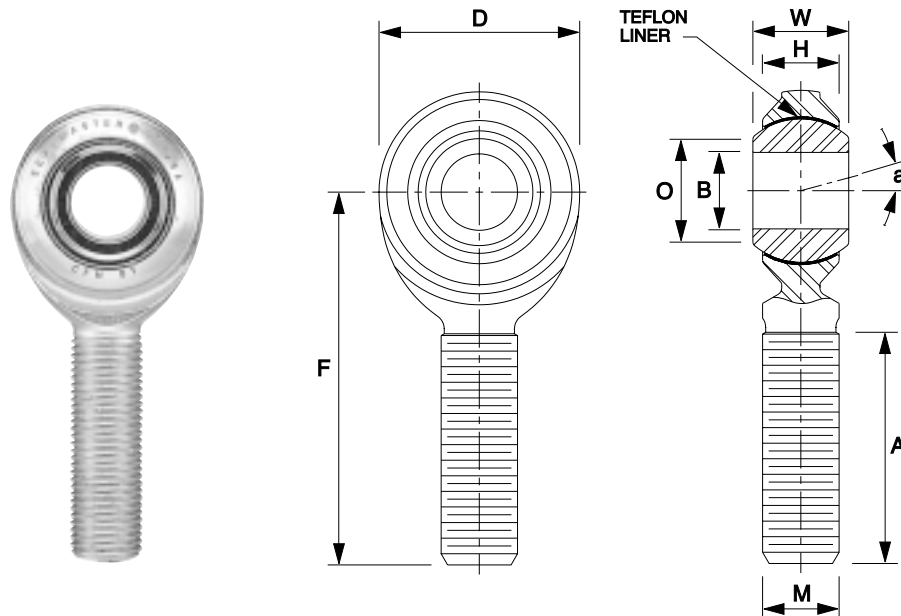

## CFM-T Series Two-Piece Precision Male Rod Ends - Self Lubricating Teflon Lined

PART NUMBER	BORE B +.0015 -.0005	BALL WIDTH W +.000 -.005	HOUSING WIDTH H REF.	HEAD DIA. D +.031 -.031	LENGTH TO CTR. OF BALL F +.015 -.015	THREAD LENGTH A MIN.	THREAD SIZE M CLASS UNF-3A	BALL DIA. REF.	BALL FLAT DIA. O REF.	MAX. STATIC RADIAL LOAD LBS.	MIS-ALIGNMENT ANGLE a DEG. +/-	APPROX. WEIGHT LBS.
CFM-3T	.1900	.312	.250	.625	1.250	.719	#10-32	.437	.306	865	6 1/2	.03
CFM-4T	.2500	.375	.281	.750	1.562	.969	1/4-28	.500	.331	1,550	8	.05
CFM-5T	.3125	.437	.344	.875	1.875	1.219	5/16-24	.625	.447	2,080	7	.08
CFM-6T	.3750	.500	.406	1.000	1.938	1.219	3/8-24	.718	.517	2,950	6	.12
CFM-7T	.4375	.562	.437	1.125	2.125	1.344	7/16-20	.812	.586	3,160	7	.17
CFM-8T	.5000	.625	.500	1.312	2.438	1.469	1/2-20	.937	.698	4,920	6	.26
CFM-10T	.6250	.750	.562	1.500	2.625	1.594	5/8-18	1.125	.839	5,460	8	.41
CFM-12T	.7500	.875	.687	1.750	2.875	1.719	3/4-16	1.312	.978	8,300	7	.64
CFM-16T	1.0000	1.375	1.000	2.750	4.125	2.094	1 1/4-12	1.875	1.269	21,000	8 1/2	2.25

CFM-T precision series male rod ends combine the strength of two-piece design and self-lubricating TEFLON for use in a wide variety of applications. These self-lubricating rod ends are used where grease relubrication is not practical or desirable and operate to 250 degrees F in normal industrial applications. A hardened steel chrome plated ball moving against a TEFLON fabric liner results in smooth operation and longer wear when compared with most metal-metal units. CFM-T rod ends are manufactured with consistent no load rotational torque values making them a popular choice in carton folding, book binding, and printing equipment applications, etc., where close tolerances and accurate linkage control are important.

### MATERIAL SPECIFICATIONS

**OUTER MEMBER** - Carbon steel with protective plating for corrosion resistance  
**BALL** - Alloy steel, heat treated, chrome plated  
**LINER** - Teflon fabric

### NOTES

1. To order left hand threaded units add letter "L" to part number prefix. Example: CFML-8T.
2. "T" in part number prefix indicates TEFLON liner.
3. Add letter "Y" to the part number suffix to indicate stud; Example: CFM-8TY.
4. For design modifications, see page 173.

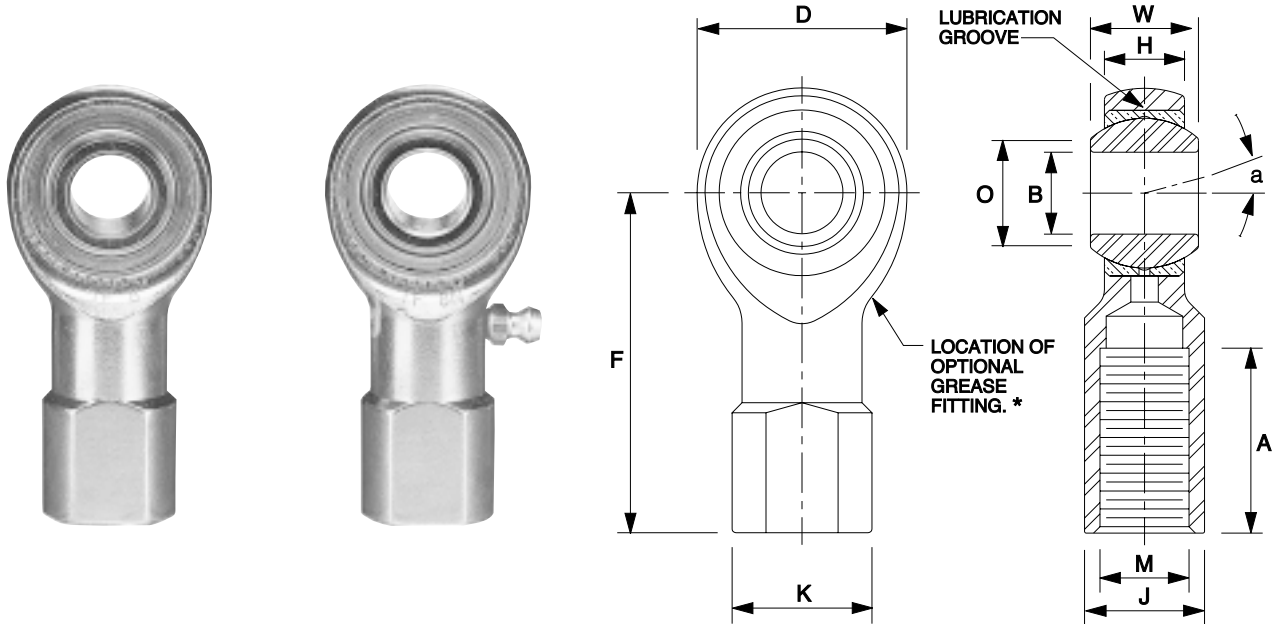

## TF, TF-N Series Three-Piece Commercial Female Rod Ends

PART NUMBER	BORE B +.0025 -.0005	BALL WIDTH W +.005 -.005	HOUSING WIDTH H +.010 -.010	HEAD DIA. D +.031 -.031	LENGTH TO CTR. OF BALL F REF.	THREAD LENGTH A MIN.	THREAD SIZE M CLASS UNF-2B	BASE DIA. K REF.	ACROSS WRENCH FLATS J +.010 -.010	BALL DIA. REF.	BALL FLAT DIA. O REF.	MAX. STATIC RADIAL LOAD LBS.	MISALIGNMENT ANGLE a DEG. +/-	APPROX. WEIGHT LBS.
TF-3	.1900	.312	.250	.625	1.062	.531	#10-32	.375	.312	.437	.306	1,850	6 1/2	.03
TF-4	.2500	.375	.281	.750	1.312	.719	1/4-28	.469	.375	.500	.331	2,700	8	.06
TF-5	.3125	.437	.344	.875	1.375	.719	5/16-24	.531	.437	.625	.447	3,350	7	.08
TF-6	.3750	.500	.406	1.000	1.625	.906	3/8-24	.688	.562	.718	.517	4,450	6	.14
TF-7	.4375	.562	.437	1.125	1.812	1.031	7/16-20	.750	.625	.812	.586	5,350	7	.18
TF-8	.5000	.625	.500	1.312	2.125	1.156	1/2-20	.875	.750	.937	.698	7,400	6	.29
TF-10	.6250	.750	.562	1.500	2.500	1.469	5/8-18	1.000	.875	1.125	.839	8,050	8	.43
TF-12	.7500	.875	.687	1.750	2.875	1.719	3/4-16	1.125	1.000	1.312	.978	11,300	7	.64

TF and TF-N commercial series female three-piece rod ends are machined from carbon steel and feature one-piece bronze races for lower friction and longer wear.

### MATERIAL SPECIFICATIONS

**OUTER MEMBER - Low carbon steel with protective plating for corrosion resistance**

**RACE - Bronze**

**BALL - Alloy steel, heat treated, chrome plated**

### NOTES

- \* 1. Rod ends with Zerk type grease fittings can be obtained by ordering the TF-N series; Example: TF-8N.
2. Grease fittings are available on sizes 4 through 12 only.
3. Optional flush type fittings are available on special order by adding "FN" suffix to the part numbers; Example: TF-8FN.
4. Load ratings apply to the TF series only. For TF-N load ratings contact engineering.
5. To order left hand threaded units add letter "L" to part number prefix; Example: TFL-8.
6. Add letter "Y" to the part number suffix to indicate stud; Example: TF-8Y.
7. For design modifications, see page 173.

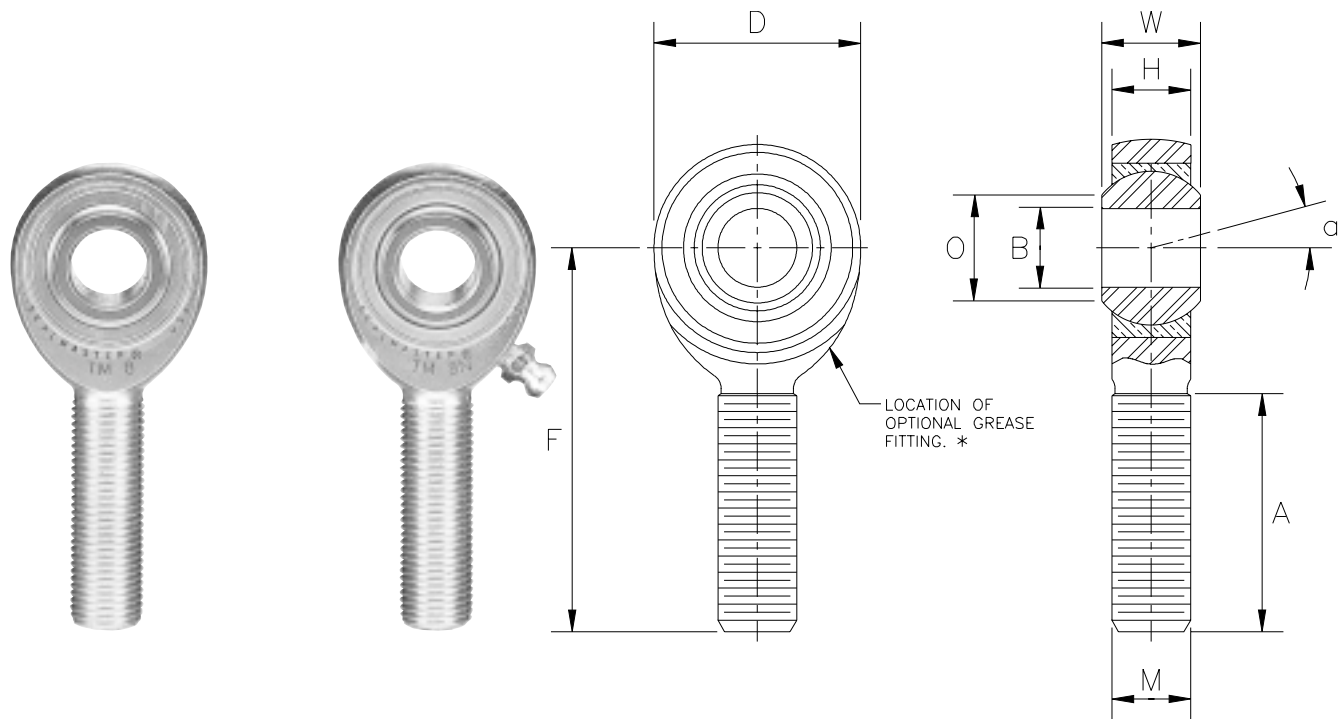
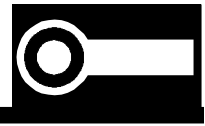

## TM, TM-N Series Three-Piece Commercial Male Rod Ends

PART NUMBER	BORE B +.0025 -.0005	BALL WIDTH W +.005 -.005	HOUSING WIDTH H +.010 -.010	HEAD DIA. D +.031 -.031	LENGTH TO CTR. OF BALL F REF.	THREAD LENGTH A MIN.	THREAD SIZE M CLASS UNF-3A	BALL DIA. REF.	BALL FLAT DIA. O REF.	MAX. STATIC RADIAL LOAD LBS.	MIS-ALIGNMENT ANGLE a DEG. +/-	APPROX. WEIGHT LBS.
TM-3	.1900	.312	.250	.625	1.250	.719	#10-32	.437	.306	900	6½	.03
TM-4	.2500	.375	.281	.750	1.562	.969	¼-28	.500	.331	1,700	8	.05
TM-5	.3125	.437	.344	.875	1.875	1.219	⅜-24	.625	.447	2,500	7	.08
TM-6	.3750	.500	.406	1.000	1.938	1.219	⅜-24	.718	.517	4,000	6	.12
TM-7	.4375	.562	.437	1.125	2.125	1.344	7/16-20	.812	.586	5,000	7	.17
TM-8	.5000	.625	.500	1.312	2.438	1.469	½-20	.937	.698	7,000	6	.26
TM-10	.6250	.750	.562	1.500	2.625	1.594	5/8-18	1.125	.839	8,050	8	.41
TM-12	.7500	.875	.687	1.750	2.875	1.719	¾-16	1.312	.978	11,300	7	.64

TM and TM-N commercial series male three-piece rod ends are machined from carbon steel and feature one-piece bronze races for lower friction and longer wear.

### MATERIAL SPECIFICATIONS

**OUTER MEMBER - Carbon steel with protective plating for corrosion resistance**

**RACE - Bronze**

**BALL - Alloy steel, heat treated, chrome plated**

### NOTES

- \* 1. Rod ends with Zerk type grease fittings can be obtained by ordering the TM-N series; Example: TM-8N.
2. Grease fittings are available on sizes 4 through 12 only.
3. Optional flush type fittings are available on special order by adding "FN" suffix to the part numbers; Example: TM-8FN.
4. Load ratings apply to the TM series only. For TM-N load ratings contact engineering.
5. To order left hand threaded units add letter "L" to part number prefix; Example: TML-8.
6. Add letter "Y" to the part number suffix to indicate stud; Example: TM-8Y.
7. For design modifications, see page 173.

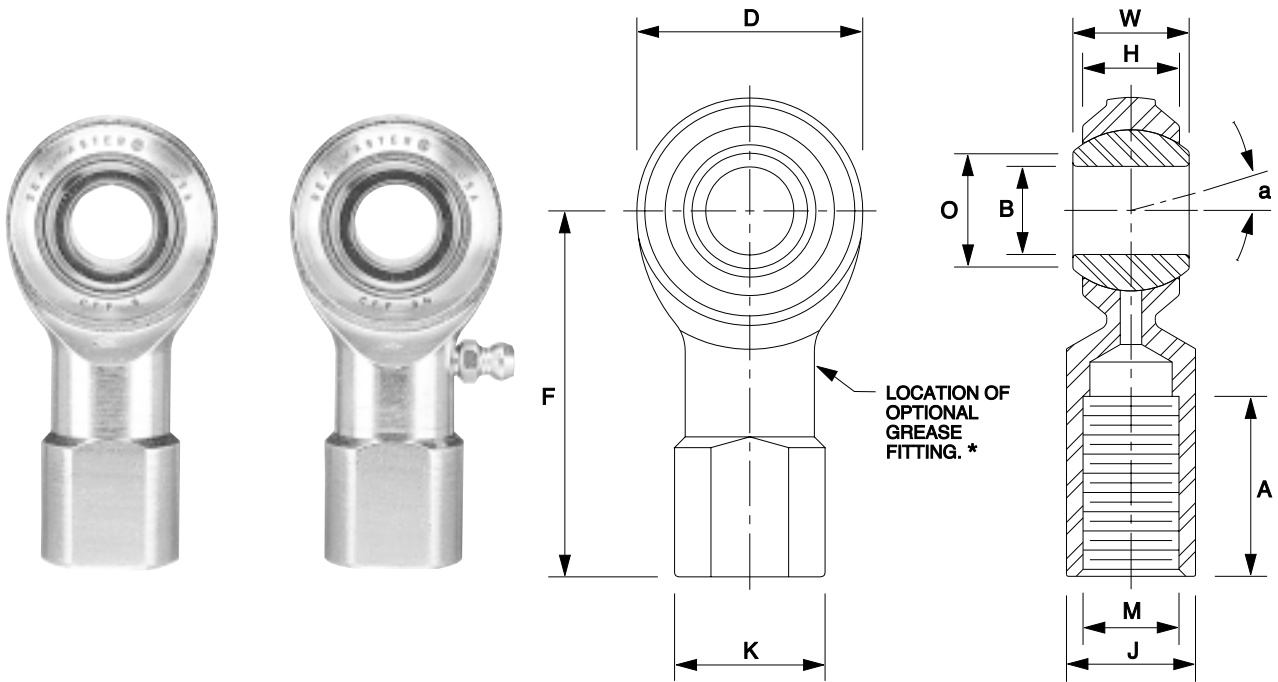

## CFF, CFF-N Series Two-Piece Commercial Female Rod Ends

PART NUMBER	BORE B +.0025 -.0005	BALL WIDTH W +.005 -.005	HOUSING WIDTH H REF.	HEAD DIA. D +.031 -.031	LENGTH TO CTR. OF BALL F REF.	THREAD LENGTH A MIN.	THREAD SIZE M CLASS UNF-2B	BASE DIA. K REF.	ACROSS WRENCH FLATS J +.010 -.010	BALL DIA. REF.	BALL FLAT DIA. O REF.	MAX. STATIC RADIAL LOAD LBS.	MIS-ALIGNMENT ANGLE a DEG. +/-	APPROX. WEIGHT LBS.
CFF-3	.1900	.312	.250	.625	1.062	.469	#10-32	.375	.312	.437	.306	2,000	6½	.03
CFF-4	.2500	.375	.281	.750	1.312	.656	¼-28	.469	.375	.500	.331	3,200	8	.06
CFF-5	.3125	.437	.344	.875	1.375	.656	5/16-24	.531	.437	.625	.447	3,800	7	.08
CFF-6	.3750	.500	.406	1.000	1.625	.781	3/8-24	.688	.562	.718	.517	5,000	6	.14
CFF-7	.4375	.562	.437	1.125	1.812	.906	7/16-20	.750	.625	.812	.586	6,500	7	.18
CFF-8	.5000	.625	.500	1.312	2.125	1.031	½-20	.875	.750	.937	.698	9,000	6	.29
CFF-10	.6250	.750	.562	1.500	2.500	1.344	5/8-18	1.000	.875	1.125	.839	10,000	8	.43
CFF-12	.7500	.875	.687	1.750	2.875	1.531	¾-16	1.125	1.000	1.312	.978	14,000	7	.64
CFF-16 <sup>8</sup>	1.0000	1.375	1.000	2.750	4.125	2.000	1 ¼-12	1.688	1.500	1.875	1.269	25,200	8½	2.25

CFF and CFF-N female commercial rod ends combine higher strength two-piece design for heavier static loads. The two-piece design provides greater housing cross section and increased load capacity than three-piece rod ends with like housing materials. This commercial series provides a lower cost alternative for applications requiring a higher static load capacity.

**MATERIAL SPECIFICATIONS**  
**OUTER MEMBER - Carbon steel with protective plating for corrosion resistance**  
**BALL - Alloy steel, heat treated, chrome plated**

### NOTES

- \* 1. Rod ends with Zerk type grease fittings can be obtained by ordering the CFF-N series; Example: CFF-8N.
- 2. Grease fittings are available on sizes 4 through 16 only.
- 3. Optional flush type fittings are available on special order by adding "FN" suffix to the part numbers; Example: CFF-8FN.
- 4. Load ratings apply to the CFF series only. For CFF-N load ratings contact engineering.
- 5. To order left hand threaded units add letter "L" to part number prefix; Example: CFFL-8.
- 6. Add letter "Y" to the part number suffix to indicate stud; Example: CFF-8Y.
- 7. For design modifications, see page 173.
- 8. New larger size.

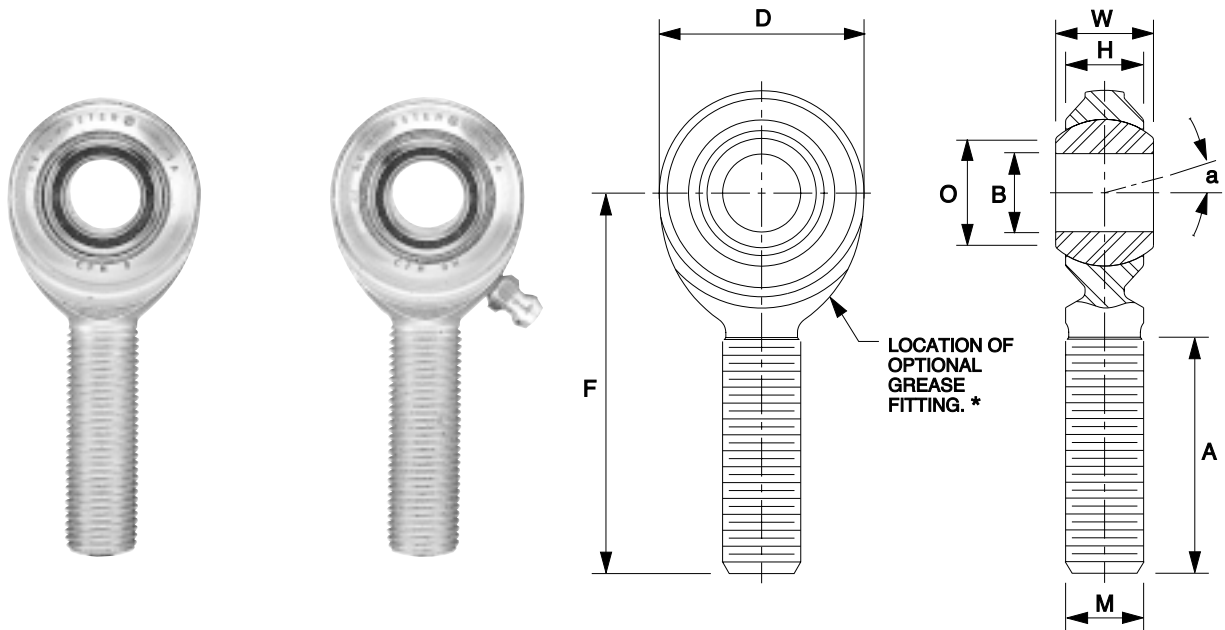
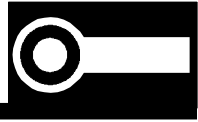

## CFM, CFM-N Series Two-Piece Commercial Male Rod Ends

PART NUMBER	BORE B +.0025 -.0005	BALL WIDTH W +.005 -.005	HOUSING WIDTH H REF.	HEAD DIA. D +.031 -.031	LENGTH TO CTR. OF BALL F REF.	THREAD LENGTH A MIN.	THREAD SIZE M CLASS UNF-3A	BALL DIA. REF.	BALL FLAT DIA. O REF.	MAX. STATIC RADIAL LOAD LBS.	MIS- ALIGN- ANGLE a DEG. +/-	APPROX. WEIGHT LBS.
CFM-3	.1900	.312	.250	.625	1.250	.719	#10-32	.437	.306	950	6½	.03
CFM-4	.2500	.375	.281	.750	1.562	.969	¼-28	.500	.331	2,000	8	.05
CFM-5	.3125	.437	.344	.875	1.875	1.219	⅝-24	.625	.447	3,000	7	.08
CFM-6	.3750	.500	.406	1.000	1.938	1.219	⅞-24	.718	.517	5,000	6	.11
CFM-7	.4375	.562	.437	1.125	2.125	1.344	7/16-20	.812	.586	6,500	7	.16
CFM-8	.5000	.625	.500	1.312	2.438	1.469	½-20	.937	.698	9,000	6	.24
CFM-10	.6250	.750	.562	1.500	2.625	1.594	⅝-18	1.125	.839	10,000	8	.40
CFM-12	.7500	.875	.687	1.750	2.875	1.719	¾-16	1.312	.978	14,000	7	.63
CFM-16*	1.0000	1.375	1.000	2.750	4.125	2.094	1 ¼-12	1.875	1.269	25,200	8½	2.25

CFM and CFM-N male commercial rod ends combine higher strength two-piece design for heavier static loads. The two-piece design provides greater housing cross section and increased load capacity than three-piece rod ends with like housing materials. This commercial series provides a lower cost alternative for applications requiring a higher static load capacity.

### MATERIAL SPECIFICATIONS

**OUTER MEMBER - Carbon steel with protective plating for corrosion resistance**  
**BALL - Alloy steel, heat treated, chrome plated**

### NOTES

- \* 1. Rod ends with Zerk type grease fittings can be obtained by ordering the CFM-N series; Example: CFM-8N.
2. Grease fittings are available on sizes 4 through 16 only.
3. Optional flush type fittings are available on special order by adding "FN" suffix to the part numbers; Example: CFM-8FN.
4. Load ratings apply to the CFM series only. For CFM-N load ratings contact engineering.
5. To order left hand threaded units add letter "L" to part number prefix; Example: CFML-8.
6. Add letter "Y" to the part number suffix to indicate stud; Example: CFM-8Y.
7. For design modifications, see page 173.
8. New larger size.



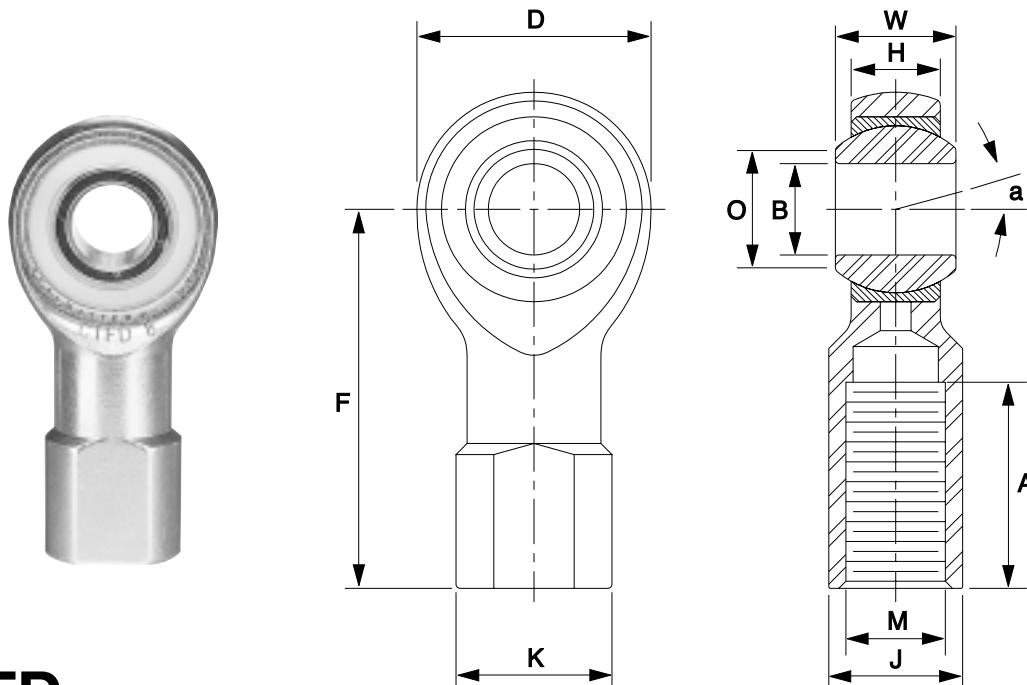

## CTFD Series Three-Piece Commercial Female Rod Ends - Self Lubricating Delrin

PART NUMBER	BORE B +.0025 -.0005	BALL WIDTH W +.005 -.005	HOUSING WIDTH H +.010 -.010	HEAD DIA. D +.031 -.031	LENGTH TO CTR. OF BALL F REF.	THREAD LENGTH A MIN.	THREAD SIZE M CLASS UNF-2B	BASE DIA. K REF.	ACROSS WRENCH FLATS J +.010 -.010	BALL DIA. REF.	BALL FLAT DIA. O REF.	MAX. STATIC RADIAL LOAD LBS.	MIS-ALIGNMENT ANGLE a DEG. +/-	APPROX. WEIGHT LBS.
CTFD-3	.1900	.312	.250	.625	1.062	.531	#10-32	.375	.312	.437	.306	800	6 1/2	.03
CTFD-4	.2500	.375	.281	.750	1.312	.719	1/4-28	.469	.375	.500	.331	1,060	8	.06
CTFD-5	.3125	.437	.344	.875	1.375	.719	5/16-24	.531	.437	.625	.447	1,570	7	.08
CTFD-6	.3750	.500	.406	1.000	1.625	.906	3/8-24	.688	.562	.718	.517	2,150	6	.14
CTFD-7	.4375	.562	.437	1.125	1.812	1.031	7/16-20	.750	.625	.812	.586	2,600	7	.18
CTFD-8	.5000	.625	.500	1.312	2.125	1.156	1/2-20	.875	.750	.937	.698	3,420	6	.29
CTFD-10	.6250	.750	.562	1.500	2.500	1.469	5/8-18	1.000	.875	1.125	.839	4,620	8	.43
CTFD-12	.7500	.875	.687	1.750	2.875	1.719	3/4-16	1.125	1.000	1.312	.978	6,600	7	.64

CTFD commercial three-piece female rod ends feature DELRIN races for applications where oil and grease should be avoided. This maintenance-free design is a popular choice in lighter duty applications such as food processing, packaging and textile equipment.

DELRIN features include:

Lower coefficient of friction than metal-to-metal types.

Withstands vibration without galling or fretting of the surface.

Absorbs less moisture compared to bearings with nylon races.

### MATERIAL SPECIFICATIONS

**OUTER MEMBER - Carbon steel with protective plating for corrosion resistance**

**RACE - DELRIN Acetal Resin**

**BALL - Alloy steel, heat treated, chrome plated**

### NOTES

1. To order left hand threaded units add letter "L" to part number prefix; Example: CTFDL-8.

2. Add letter "Y" to the part number suffix to indicate stud; Example: CTFD-8Y.

3. For design modifications, see page 173.

4. Caution: Prolonged exposure to ultraviolet light can cause loss of mechanical properties in DELRIN material.

Consult our engineering department for application assistance.



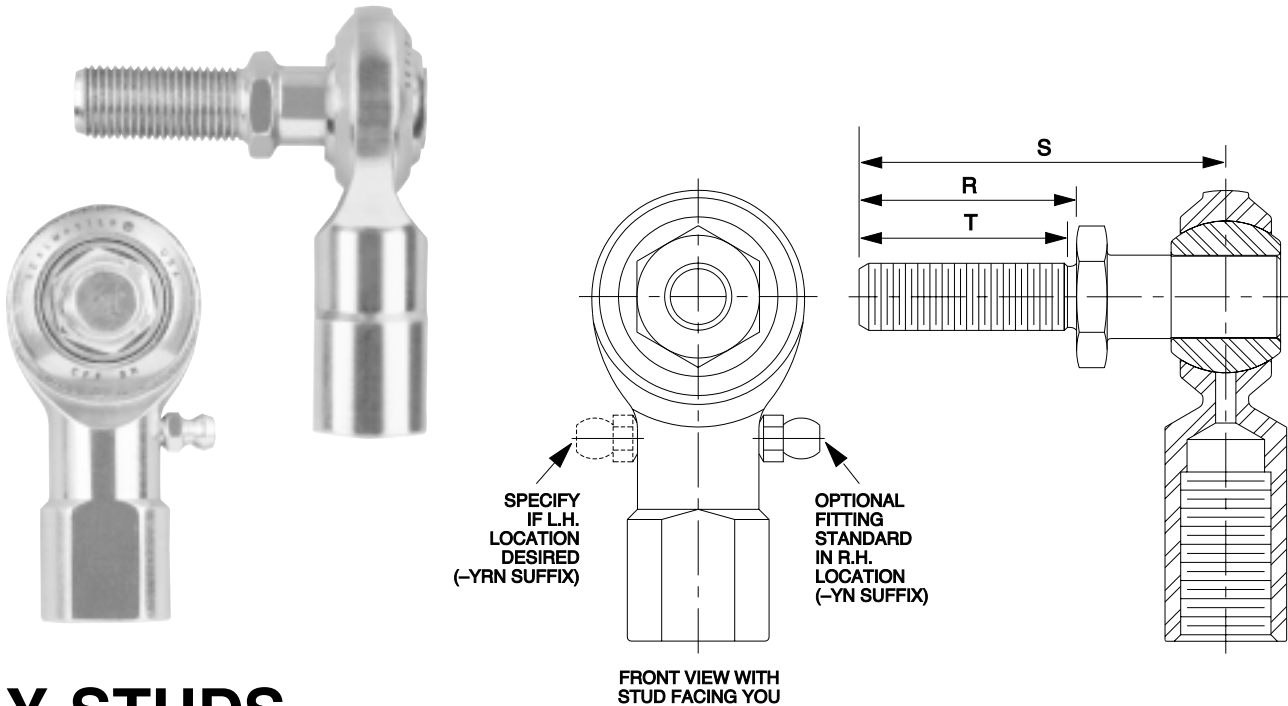

## Y-STUDS

STUD SIZE	R +.031 -.031	S +.031 -.031	T MIN.	THREAD SIZE CLASS UNF-2A
-3	.500	.968	$\frac{7}{16}$	#10-32
-4	.562	1.047	$\frac{1}{2}$	$\frac{1}{4}$ -28
-5	.687	1.234	$\frac{19}{32}$	$\frac{5}{16}$ -24
-6	.906	1.540	$\frac{13}{16}$	$\frac{3}{8}$ -24
-7	1.125	1.930	1	$\frac{7}{16}$ -20
-8	1.125	2.000	1	$\frac{1}{2}$ -20
-10	1.500	2.500	$1 \frac{3}{8}$	$\frac{5}{8}$ -18
-12	1.812	3.000	$1 \frac{5}{8}$	$\frac{3}{4}$ -16

### AVAILABLE AS:

**TR-Y, TRE-Y SERIES**  
**CFF-TY, CFM-TY SERIES**  
**TF-Y, TM-Y SERIES**  
**CTFD-Y, CTMD-Y SERIES**  
**CFF-Y, CFM-Y SERIES**

**SEALMASTER Y-studs** are available in all of the above rod end designs to facilitate right angle connections in a wide variety of linkage applications. Y-studs are manufactured from carbon steel and plated for corrosion protection. They are secured in the bore, threaded for mounting and manufactured with a hex wrench flat to accommodate tightening. Rod ends with Y-studs can accommodate up to  $\pm 25$  degrees of angular misalignment in any direction for maximum flexibility in linkage design.

To order, simply add the letter Y to the rod end part number; Example: TR-8Y.

### NOTE

Caution when selecting rod ends with Y-studs: Catalog load ratings are not applicable with Y-studs because of the reduced stud strength due to bending. For load ratings with Y-studs contact our engineering department.

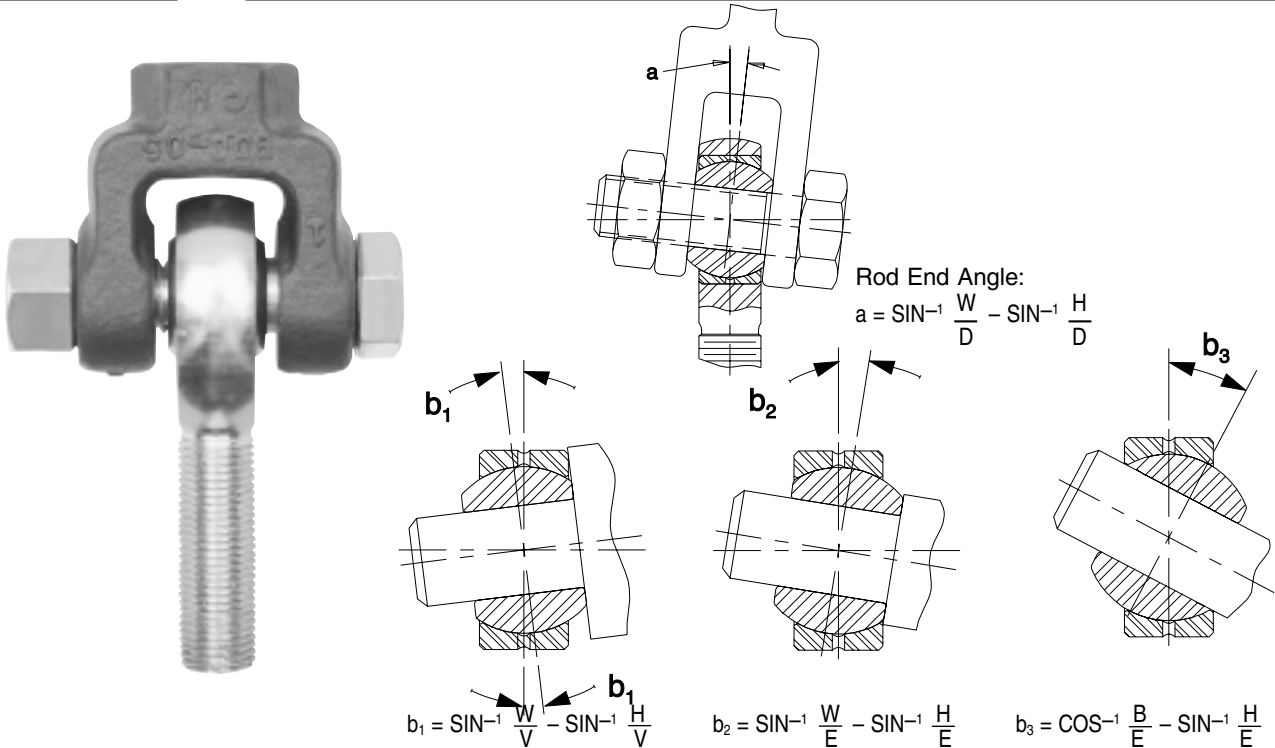

## MISALIGNMENT CAPABILITIES

### SPHERICAL BEARINGS

SERIES SBG, SBG-S, SBG-SS, SBG-SA, COM, COR			
PART NO.	(+/-) b <sub>1</sub>	(+/-) b <sub>2</sub>	(+/-) b <sub>3</sub>
-3	7 1/2	11 1/2	29 1/2
-4	9	13 1/2	30
-5	8	12	26
-6	7 1/2	10	26 1/2
-7	6 1/2	9 1/2	20 1/2
-8	7	10	20
-10	6 1/2	9	18 1/2
-12	7	9	21
-14	7	9 1/2	16
-16	7	9 1/2	16

SERIES FLBG			
PART NO.	(+/-) b <sub>1</sub>	(+/-) b <sub>2</sub>	(+/-) b <sub>3</sub>
-3	9 1/2	16 1/2	34 1/2
-4	8	14 1/2	26
-5	9	14 1/2	30
-6	8	12 1/2	27
-7	6 1/2	11	25
-8	7 1/2	12 1/2	23
-10	7 1/2	12	23
-12	8 1/2	15	27 1/2
-16	6 1/2	10	25

SERIES BH-LS			
PART NO.	(+/-) b <sub>1</sub>	(+/-) b <sub>2</sub>	(+/-) b <sub>3</sub>
-16	6 1/2	9	26
-19	6 1/2	8 1/2	25 1/2
-20	6 1/2	8 1/2	23 1/2
-24	6	8	21 1/2
-28	6	8	20
-32	6 1/2	8 1/2	19

SERIES BTS-LS	
PART NO.	(+/-) b <sub>2</sub>
-12	13 1/2
-16	12
-20	9 1/2
-24	7 1/2

### ROD ENDS

SERIES AR, ARE, ARE-20, TR, TRE, CFF-T, CFM-T, TF, TM, CFF, CFM, CTFD, CTMD	
PART NO.	(+/-) a
-3	6 1/2
-4	8
-5	7
-6	6
-7	7
-8	6
-10	8
-12	7
-16	8 1/2

The angle of misalignment in a rod end is controlled by the outside diameter of the head and ball width. The maximum degree of misalignment is obtained when the head contacts the inside of the fork or clevis in which it is mounted. Greater than catalog misalignment can be accomplished by adding a spacer washer between the ball flat and the clevis I.D. or by selecting a rod end with a Y-Stud.

The angle of misalignment in a spherical bearing is calculated somewhat differently than a rod end. Illustrated above are common mountings for spherical bearings and the corresponding formula for calculating the angle of misalignment.

#### Reference Letters

- B** = Bore of Ball
- C** = Chamfer on Outer Race
- D** = Head or Diameter of Outer Race
- E** = Ball Diameter
- H** = Housing Width
- V** =  $\sqrt{(D - 2C)^2 + H^2}$
- W** = Ball Width



Typical SBG Series

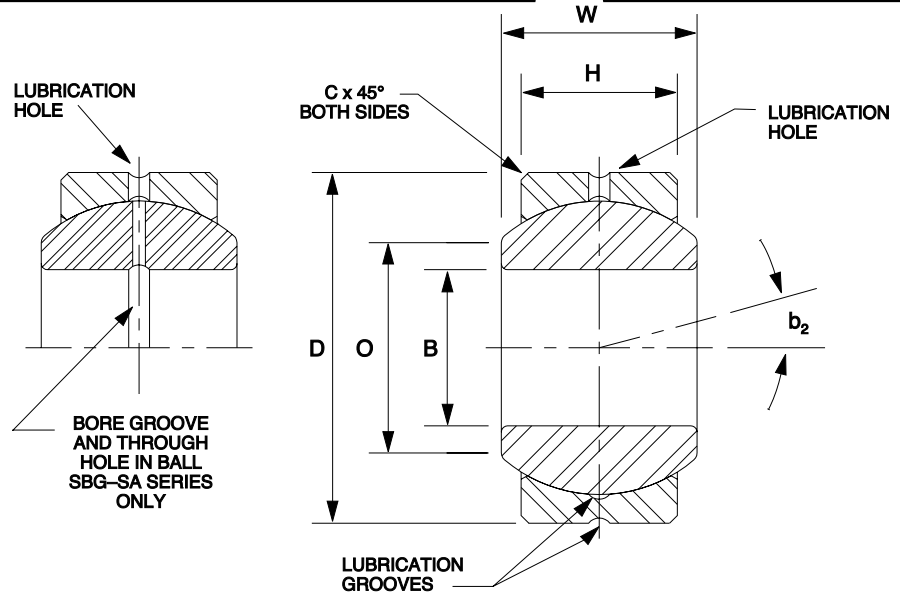

## SBG, SBG-S, SBG-SA, SBG-SS

Series Two-Piece Precision Spherical Bearings

SPHERICAL BEARING PART NUMBER				BORE B	OUTSIDE DIA. D	BALL WIDTH W	RACE WIDTH H	CHAMFER C	BALL DIA. REF.	BALL FLAT DIA. O REF.	SBG SERIES MAX. STATIC RADIAL LOAD RATING LBS.	SBG-S SERIES STATIC RADIAL LOAD RATING LBS.	SBG-SA SERIES STATIC RADIAL LOAD RATING LBS.	SBG-SS SERIES STATIC RADIAL LOAD RATING LBS.	MISALIGNMENT ANGLE b <sub>2</sub> DEG. +/-	APPROX. WEIGHT LBS.
SBG-3	SBG-3S		SBG-3SS	.1900	.5625	.281	.218	.025	.406	.293	2,750	6,480		4,400	11½	.02
SBG-4	SBG-4S		SBG-4SS	.2500	.6562	.343	.250	.025	.500	.364	4,200	10,000		6,700	13½	.02
SBG-5	SBG-5S		SBG-5SS	.3125	.7500	.375	.281	.025	.562	.419	5,800	13,900		9,200	12	.03
SBG-6	SBG-6S		SBG-6SS	.3750	.8125	.406	.312	.030	.656	.515	7,750	18,700		12,400	10	.04
SBG-7	SBG-7S		SBG-7SS	.4375	.9062	.437	.343	.035	.687	.530	9,300	22,300		14,900	9½	.05
SBG-8	SBG-8S	SBG-8SA	SBG-8SS	.5000	1.0000	.500	.390	.035	.781	.600	11,200	26,900	26,900	17,900	10	.07
SBG-10	SBG-10S	SBG-10SA	SBG-10SS	.6250	1.1875	.625	.500	.035	.968	.739	20,000	48,000	48,000	32,000	9	.12
SBG-12	SBG-12S	SBG-12SA	SBG-12SS	.7500	1.4375	.750	.593	.045	1.187	.920	30,000	78,000	78,000	48,000	9	.21
SBG-14	SBG-14S	SBG-14SA	SBG-14SS	.8750	1.5625	.875	.703	.045	1.312	.980	43,000	103,000	103,000	69,000	9½	.27
SBG-16	SBG-16S	SBG-16SA	SBG-16SS	1.0000	1.7500	1.000	.797	.045	1.500	1.118	52,000	125,000	125,000	83,000	9½	.38

The **SBG/SBG-S/SBG-SA/SBG-SS** family of metal-to-metal spherical bearings have common mounting dimensions and are manufactured in a variety of material combinations tailored for a wide range of applications. The bearings have lubrication grooves in the outer race and an interconnecting hole for grease lubrication. The outer races are chamfered on the O.D. to facilitate installation and retention into housings. Common applications include shock absorbers, industrial fans, packaging equipment, cylinders etc.

### MATERIAL SPECIFICATIONS

**SBG** - Bronze race for lower coefficient of friction - General purpose applications

OUTER RACE - Aluminum bronze

BALL - Alloy steel, heat treated, chrome plated

**SBG-S** - Heat treated race for higher load capacity and increased wear life

OUTER RACE - 4130 Alloy steel, heat treated, with protective plating for corrosion resistance

BALL - Alloy steel, heat treated, chrome plated

**SBG-SA** - Groove on ball I.D. and interconnecting hole to facilitate lubrication from the shaft to the bearing

OUTER RACE - 4130 Alloy steel, heat treated, with protective plating for corrosion resistance

BALL - Alloy steel, heat treated, chrome plated

**SBG-SS** - Stainless race and ball to improve corrosion resistance

OUTER RACE - 300 Series stainless steel

BALL - Stainless steel, heat treated

### NOTES:

1. Add letter "A" to suffix to indicate cross drilled oil hole in ball and race and a grooved I.D. on ball.
2. For design modifications, see page 173.
3. For mounting information, see Recommended Housing Bore Diameters page 172.



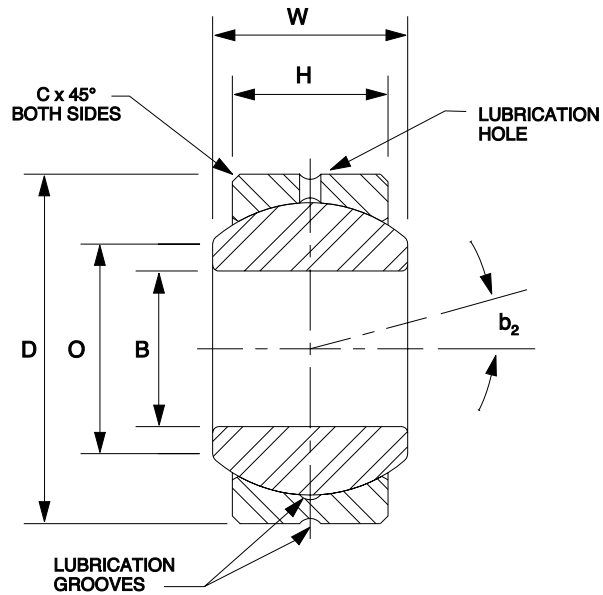

## COR Series Corrosion-Resistant Two-Piece Precision Spherical Bearings

PART NUMBER	BORE B +.0000 -.0005	OUTSIDE DIA. D +.0000 -.0005	BALL WIDTH W +.000 -.005	RACE WIDTH H +.005 -.005	CHAM- FER C REF.	BALL DIA. REF.	BALL FLAT DIA. O REF.	MAX. STATIC RADIAL LOAD LBS.	MIS- ALIGN- MENT ANGLE b <sub>2</sub> DEG. +/-	APPROX. WEIGHT LBS.
COR-3	.1900	.5625	.281	.218	.025	.406	.293	4,800	11½	.02
COR-4	.2500	.6562	.343	.250	.025	.500	.364	7,500	13½	.02
COR-5	.3125	.7500	.375	.281	.025	.562	.419	10,400	12	.03
COR-6	.3750	.8125	.406	.312	.030	.656	.515	14,000	10	.04
COR-8	.5000	1.0000	.500	.390	.035	.781	.600	20,000	10	.07
COR-10	.6250	1.1875	.625	.500	.035	.968	.739	36,000	9	.12
COR-12	.7500	1.4375	.750	.593	.045	1.187	.920	54,000	9	.21
COR-14	.8750	1.5625	.875	.703	.045	1.312	.980	77,000	9½	.27
COR-16	1.0000	1.7500	1.000	.797	.045	1.500	1.118	93,500	9½	.38

The COR corrosion-resistant spherical bearing series is manufactured with a heat treated stainless steel race and ball for improved corrosion resistance and higher load capacity.

**MATERIAL SPECIFICATIONS**  
**OUTER RACE - Stainless steel, heat treated**  
**BALL - Stainless steel, heat treated**

### NOTES

1. For mounting information, see Recommended Housing Bore Diameters, page 172.

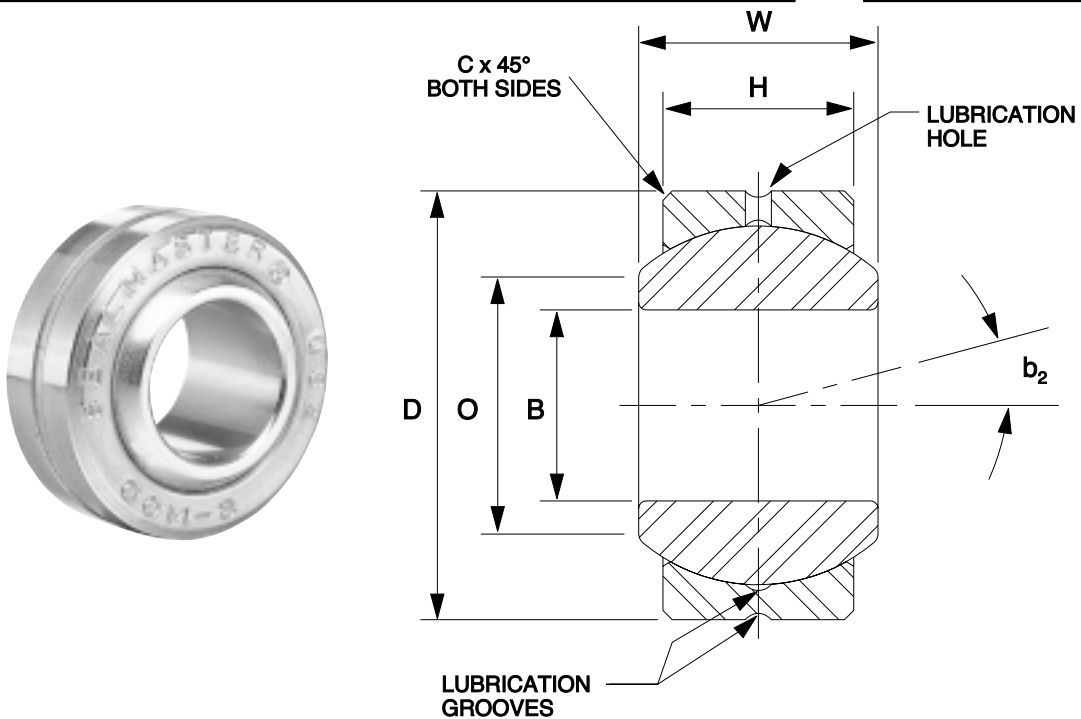

## COM Series Two-Piece Commercial Spherical Bearings

PART NUMBER	BORE B +.0015 -.0005	OUTSIDE DIA. D +.0000 -.0007	BALL WIDTH W +.005 -.005	RACE WIDTH H +.010 -.010	CHAMFER C REF.	BALL DIA. REF.	BALL FLAT DIA. O REF.	MAX. STATIC RADIAL LOAD LBS.	MIS-ALIGNMENT ANGLE $b_2$ DEG. +/-	APPROX. WEIGHT LBS.
COM-3	.1900	.5625	.281	.218	.025	.406	.293	3,250	11½	.02
COM-4	.2500	.6562	.343	.250	.025	.500	.364	4,900	13½	.02
COM-5	.3125	.7500	.375	.281	.025	.562	.419	6,450	12	.03
COM-6	.3750	.8125	.406	.312	.030	.656	.515	8,250	10	.04
COM-7	.4375	.9062	.437	.343	.035	.687	.530	10,200	9½	.05
COM-8	.5000	1.0000	.500	.390	.035	.781	.600	13,600	10	.07
COM-10	.6250	1.1875	.625	.500	.035	.968	.739	21,000	9	.12
COM-12	.7500	1.4375	.750	.593	.045	1.187	.920	30,000	9	.21
COM-14	.8750	1.5625	.875	.703	.045	1.312	.980	41,100	9½	.27
COM-16	1.0000	1.7500	1.000	.797	.045	1.500	1.118	54,700	9½	.38

COM commercial series spherical bearings are an economical alternative in a wide variety of industrial applications where a precision ball bore and close tolerances are not required.

**MATERIAL SPECIFICATIONS**  
**OUTER RACE - Carbon steel with protective coating for corrosion resistance**  
**BALL - Alloy steel, heat treated, chrome plated**

### NOTES

1. For design modifications, see page 173.
2. For mounting information, see Recommended Housing Bore Diameters, page 172.

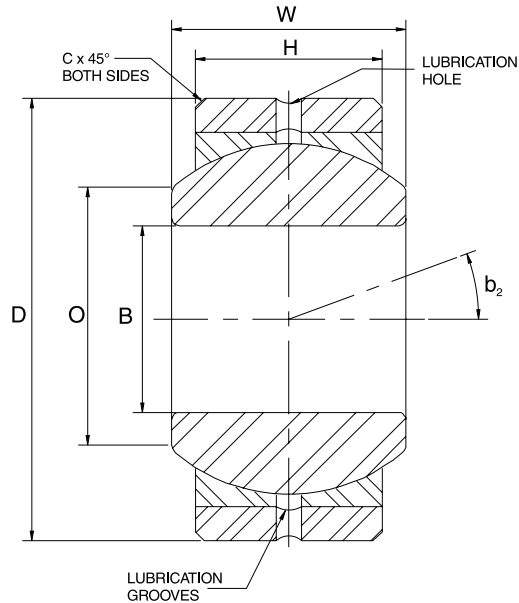

## FLBG Series Three-Piece Precision Spherical Bearings

PART NUMBER	BORE B +.0000 -.0005	OUTSIDE DIA. D +.0000 -.0005	BALL WIDTH W +.000 -.005	RACE WIDTH H +.000 -.005	CHAM- FER C REF.	BALL DIA. REF.	BALL FLAT DIA. O REF.	MAX. STATIC RADIAL LOAD LBS.	MIS- ALIGN- MENT ANGLE b <sub>2</sub> DEG. +/-	APPROX. WEIGHT LBS.
FLBG-3	.1900	.6250	.281	.187	.020	.406	.293	2,960	16½	.02
FLBG-4	.2500	.7500	.375	.281	.020	.500	.331	5,240	14½	.04
FLBG-5	.3125	.8750	.437	.313	.025	.625	.447	6,550	14½	.05
FLBG-6	.3750	1.0000	.500	.375	.025	.718	.517	8,600	12½	.08
FLBG-7	.4375	1.1875	.562	.437	.040	.812	.586	11,100	11	.12
FLBG-8	.5000	1.3125	.687	.531	.045	.937	.637	15,600	12½	.18
FLBG-10	.6250	1.5625	.875	.687	.045	1.187	.802	25,700	12	.33
FLBG-12	.7500	2.2500	1.250	.937	.050	1.625	1.038	47,600	15	.97
FLBG-16	1.0000	2.3750	1.125	.875	.065	1.750	1.345	48,200	10	.94

FLBG series spherical bearings are manufactured with a one-piece bronze race mounted in a carbon steel housing and contain a hardened steel chrome plated ball for improved spherical conformity and even load distribution. The FLBG has specialized mounting dimensions and will not interchange with other catalog spherical bearings with like bore sizes.

### MATERIAL SPECIFICATIONS

**OUTER MEMBER - Carbon steel with protective plating for corrosion resistance**

**RACE - Bronze**

**BALL - Alloy steel, heat treated, chrome plated**

### NOTES

1. For mounting information, see Recommended Housing Bore Diameters, page 172.

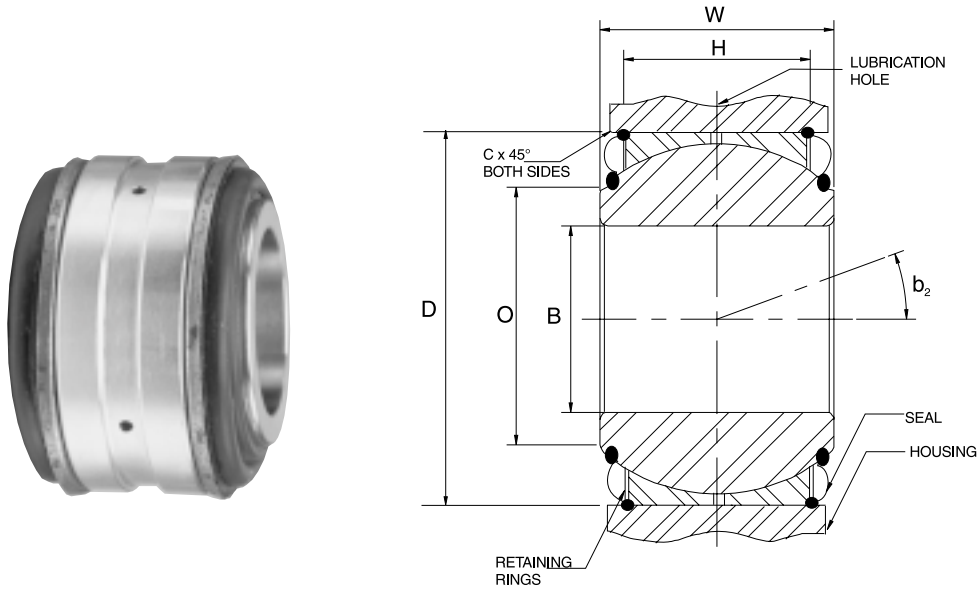

## BTS-LS Series Heavy Duty Sealed Two-Piece Precision Spherical Bearings

PART NUMBER	BORE B +.0000 -.0007	OUTSIDE DIA. D +.0000 -.0007	BALL WIDTH W +.000 -.005	RACE WIDTH H +.005 -.005	CHAMFER C REF.	BALL DIA. REF.	BALL FLAT DIA. O REF.	MAX. STATIC RADIAL LOAD LBS.	MISALIGNMENT ANGLE b <sub>2</sub> DEG. +/-	APPROX. WEIGHT LBS.
BTS-12LS	.7500	1.5000	1.250	.500	.015	1.250	1.000	31,500	13½	.25
BTS-16LS	1.0000	2.2500	1.875	.875	.015	1.813	1.375	83,500	12	.95
BTS-20LS	1.2500	2.3750	1.875	.875	.015	2.000	1.625	94,000	9½	.99
BTS-24LS	1.5000	2.7500	1.875	1.000	.015	2.375	2.000	130,000	7½	1.44

PART NUMBER	HOUSING WIDTH (REF.)	GROOVE SPACING E +/- .002	RECOMMENDED SNAP RING	GROOVE DIA. Z	GROOVE WIDTH J
BTS-12LS	1.250	0.507	TRUARC #5000-150	1.576/1.584	.056/.060
			SPIROLOX #RR-150	1.551/1.556	.045/.048
BTS-16LS	1.687	0.882	TRUARC #5000-225	2.364/2.376	.086/.091
			SPIROLOX #RR-225	2.324/2.330	.055/.058
BTS-20LS	1.687	0.882	TRUARC #5000-237	2.499/2.511	.086/.091
			SPIROLOX #RR-237	2.453/2.459	.055/.058
BTS-24LS	1.875	1.007	TRUARC #5000-275	2.894/2.906	.103/.108
			SPIROLOX #RR-275	2.841/2.847	.055/.058

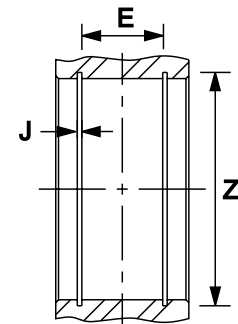

BTS-LS precision series *sealed* spherical bearings were developed for those difficult applications where bearings would be exposed to dust, dirt and grime. Two bellows type seals integral with each bearing help reduce contaminant entry as well as seal in lubricant.

### MATERIAL SPECIFICATION

**OUTER RACE - Carbon steel with protective plating for corrosion resistance**  
**BALL - Alloy steel, heat treated, chrome plated**  
**SEALS - Synthetic Rubber**

### NOTES

1. Retaining rings are NOT furnished with the bearings.
2. For mounting information, see Recommended Housing Bore Diameters, page 172.

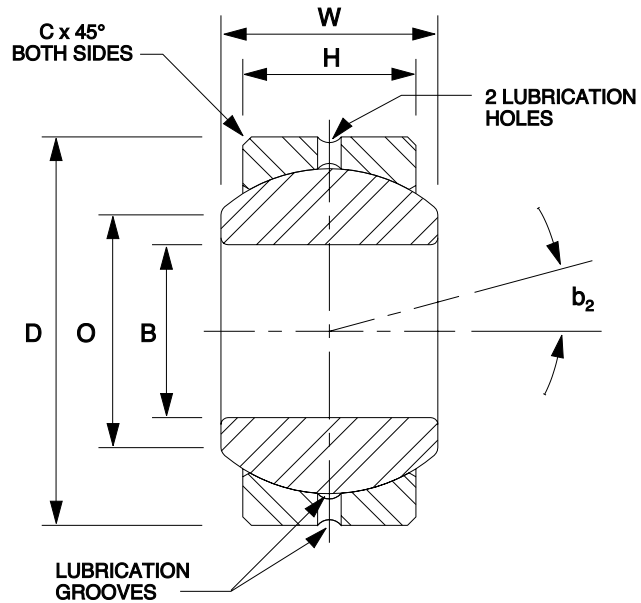

## BH-LS Series Heavy Duty Two-Piece Precision Spherical Bearings

PART NUMBER	BORE B +.0000 -.0007	OUTSIDE DIA. D +.0000 -.0007	BALL WIDTH W +.000 -.005	RACE WIDTH H +.007 -.007	CHAMFER C REF.	BALL DIA. REF.	BALL FLAT DIA. O REF.	MAX. STATIC RADIAL LOAD LBS.	MIS-ALIGNMENT ANGLE b <sub>2</sub> DEG. +/-	APPROX. WEIGHT LBS.
BH-16LS	1.0000	2.0000	1.000	.781	.035	1.687	1.360	69,500	9	.55
BH-19LS	1.1875	2.3750	1.187	.937	.035	2.000	1.610	100,000	8½	.94
BH-20LS	1.2500	2.3750	1.187	.937	.035	2.000	1.610	100,000	8½	.90
BH-24LS	1.5000	2.7500	1.375	1.094	.035	2.312	1.860	135,000	8	1.36
BH-28LS	1.7500	3.1250	1.562	1.250	.040	2.625	2.110	178,000	8	1.95
BH-32LS	2.0000	3.5000	1.750	1.375	.040	2.937	2.360	221,000	8½	2.64

The BH-LS series is generally selected for use in heavier duty, higher load applications such as bearing connectors at the ends of hydraulic cylinders and mechanical shock arrestors, etc.

### MATERIAL SPECIFICATION

**OUTER RACE - Carbon steel with protective plating for corrosion resistance**

**BALL - Alloy steel, heat treated, chrome plated**

### NOTES

1. For mounting information, see Recommended Housing Bore Diameters, page 172.



**RECOMMENDED HOUSING BORE DIAMETERS – SPHERICAL BEARINGS**





SPHERICAL BEARINGS		HOUSING BORE			
SERIES	BEARING O.D.	STEEL HOUSING		ALUMINUM HOUSING	
SBG, SBG-S, SBG-SS, SBG-SA	+ .0000/- .0005	MIN	MAX	MIN	MAX
3	.5625	.5616	.5620	.5614	.5619
4	.6562	.6553	.6557	.6551	.6556
5	.7500	.7491	.7495	.7489	.7494
6	.8125	.8116	.8120	.8114	.8119
7	.9062	.9053	.9057	.9051	.9056
8	1.0000	.9991	.9995	.9989	.9994
10	1.1875	1.1866	1.1870	1.1864	1.1869
12	1.4375	1.4366	1.4370	1.4364	1.4369
14	1.5625	1.5616	1.5620	1.5614	1.5619
16	1.7500	1.7491	1.7495	1.7489	1.7494
SERIES FLBG	+ .0000/- .0005	MIN	MAX	MIN	MAX
3	.6250	.6241	.6245	.6239	.6244
4	.7500	.7491	.7495	.7489	.7494
5	.8750	.8741	.8745	.8739	.8744
6	1.0000	.9991	.9995	.9989	.9994
7	1.1875	1.1865	1.1870	1.1863	1.1869
8	1.3125	1.3115	1.3120	1.3113	1.3119
10	1.5625	1.5613	1.5620	1.5611	1.5619
12	2.2500	2.2488	2.2495	2.2486	2.2494
16	2.3750	2.3738	2.3745	2.3736	2.3744
SERIES COM	+ .0000/- .0007	MIN	MAX	MIN	MAX
3	.5625	.5615	.5619	.5613	.5618
4	.6562	.6552	.6556	.6550	.6555
5	.7500	.7490	.7494	.7488	.7493
6	.8125	.8115	.8119	.8113	.8118
7	.9062	.9052	.9056	.9050	.9055
8	1.0000	.9990	.9994	.9988	.9993
10	1.1875	1.1864	1.1869	1.1862	1.1868
12	1.4375	1.4364	1.4369	1.4362	1.4368
14	1.5625	1.5614	1.5619	1.5612	1.5618
16	1.7500	1.7489	1.7494	1.7487	1.7493
SERIES COR	+ .0000/- .0005	MIN	MAX	MIN	MAX
3	.5625	.5616	.5620	.5614	.5619
4	.6562	.6553	.6557	.6551	.6556
5	.7500	.7491	.7495	.7489	.7494
6	.8125	.8116	.8120	.8114	.8119
8	1.0000	.9991	.9995	.9989	.9994
10	1.1875	1.1866	1.1870	1.1864	1.1869
12	1.4375	1.4366	1.4370	1.4364	1.4369
14	1.5625	1.5616	1.5620	1.5614	1.5619
16	1.7500	1.7491	1.7495	1.7489	1.7494
SERIES BTS-LS	+ .0000/- .0007	MIN	MAX	MIN	MAX
12	1.5000	1.4988	1.4993	1.4986	1.4992
16	2.2500	2.2488	2.2493	2.2486	2.2492
20	2.3750	2.3738	2.3743	2.3736	2.3742
24	2.7500	2.7488	2.7493	2.7486	2.7492
SERIES BH-LS	+ .0000/- .0007	MIN	MAX	MIN	MAX
16	2.0000	1.9988	1.9993	1.9986	1.9992
19	2.3750	2.3738	2.3743	2.3736	2.3742
20	2.3750	2.3738	2.3743	2.3736	2.3742
24	2.7500	2.7488	2.7493	2.7486	2.7492
28	3.1250	3.1238	3.1243	3.1236	3.1242
32	3.5000	3.4988	3.4993	3.4986	3.4992



# SEALMASTER® ROD ENDS & SPHERICAL BEARINGS

## DESIGN MODIFICATIONS

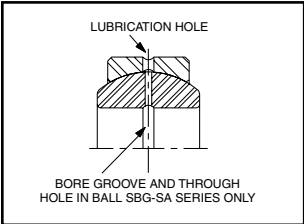
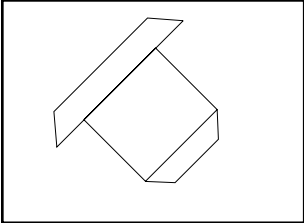
SEALMASTER rod ends and spherical bearings can be ordered with the following design modifications at extra cost

	DESIGN MODIFICATION	OPTION OFFERED ON THESE SERIES	ORDERING INSTRUCTIONS & EXAMPLE FOR SPECIFYING
<b>STOCK MODIFICATIONS</b>			
	Zerk Type Fitting	<b>AR, ARE, ARE-20 TR, TRE, TF, TM CFF, CFM</b>	Add "N" to part number suffix Example: a TRE-8 with a Zerk type fitting would be a TRE-8N (available on sizes 4 through 16 only)
	Y-Studs	<b>TR, TRE, TF, TM CFF, CFM CFF-T, CFM-T CTFD, CTMD</b>	Add "Y" to part number suffix Example: a TRE-8 with a stud would be a TRE-8Y (see page 164 for stud specifications).  Caution when selecting rod ends with Y-studs: Catalog load ratings are not applicable with Y-studs because of the reduced stud strength due to bending. For load ratings with Y-studs contact our engineering department.
<b>SPECIAL MODIFICATIONS</b>			
	Groove on Ball I.D. and Interconnecting Hole	<b>SBG, COM</b>	Add "A" to part number suffix Example: SBG-8A
	Flush Type Fitting	<b>AR, ARE, ARE-20 TR, TRE, TF, TM CFF, CFM</b>	Add "FN" to part number suffix Example: a TRE-8 with a flush type fitting would be a TRE-8FN (available on sizes 4 through 16 only)
	Alloy Steel Race	<b>AR, ARE, ARE-20 TR, TRE</b>	Add "S" to part number suffix Example: ARE-8S
	Stainless Steel Race	<b>AR, ARE, ARE-20 TR, TRE</b>	Add "SS" to part number suffix Example: TRE-6SS

# SEALMASTER<sup>®</sup> ROD ENDS & SPHERICAL BEARINGS

## APPLICATION INQUIRY WORKSHEET

\_\_\_\_\_  
Company Name

\_\_\_\_\_  
Address

\_\_\_\_\_

\_\_\_\_\_  
Contact

\_\_\_\_\_  
Phone

\_\_\_\_\_  
Fax

\_\_\_\_\_  
Date

### I. APPLICATION

- Currently in use (if current application, what bearings are now being used?)  
\_\_\_\_\_
- New \_\_\_\_\_
- Manufacturer \_\_\_\_\_
- Manufacturer's Part Number \_\_\_\_\_
- Your Company's Part Number \_\_\_\_\_
- Application Detail \_\_\_\_\_

### II. ENGINEERING DETAIL

- |  |                               |                                      |                                       |
|--|-------------------------------|--------------------------------------|---------------------------------------|
| <input type="checkbox"/> Rod End           | <input type="checkbox"/> 2 pc | <input type="checkbox"/> Steel Race  | <input type="checkbox"/> DELRIN Race  |
| <input type="checkbox"/> Spherical Bearing | <input type="checkbox"/> 3 pc | <input type="checkbox"/> Bronze Race | <input type="checkbox"/> TEFLON Liner |
- Misalignment Angle \_\_\_\_\_ (Degrees)
- Radial Clearance \_\_\_\_\_ (Min/Max)
- Axial Clearance \_\_\_\_\_ (Min/Max)
- Preload Torque (lined rod ends only) \_\_\_\_\_ Min \_\_\_\_\_ Max
- Materials: Ball \_\_\_\_\_ Race \_\_\_\_\_ Housing \_\_\_\_\_
- Protective Finish: Ball \_\_\_\_\_ Race \_\_\_\_\_ Housing \_\_\_\_\_
- |   |   |                                  |
|---|---|----------------------------------|
| <input type="checkbox"/> Solid Film     | <input type="checkbox"/> Race ID          | <input type="checkbox"/> Ball ID |
| <input type="checkbox"/> Ball & Race ID | <input type="checkbox"/> Grease (Specify) |                                  |

### III. OPERATING CONDITIONS

- Radial \_\_\_\_\_ Lbs.
- Axial \_\_\_\_\_ Lbs.
- Type:  Reversing  Alternating  Unidirectional
- Vibrating  Static
- Operating Temperature Range \_\_\_\_\_
- Operating Speeds \_\_\_\_\_
- Motion \_\_\_\_\_ (Degrees/Cycle)
- Environmental Conditions  Dry  Moisture  Corrosive
- Contamination
- Bearing Life Required \_\_\_\_\_

**REMARKS – Specify bearing dimensions on reverse side – please attach part drawing or sketch if available**

Fax your application worksheet to:

**SEALMASTER ENGINEERING**  
Aurora, Illinois  
630-898-6064

\_\_\_\_\_  
Customer Signature

\_\_\_\_\_  
Date

# APPLICATION INQUIRY WORKSHEET

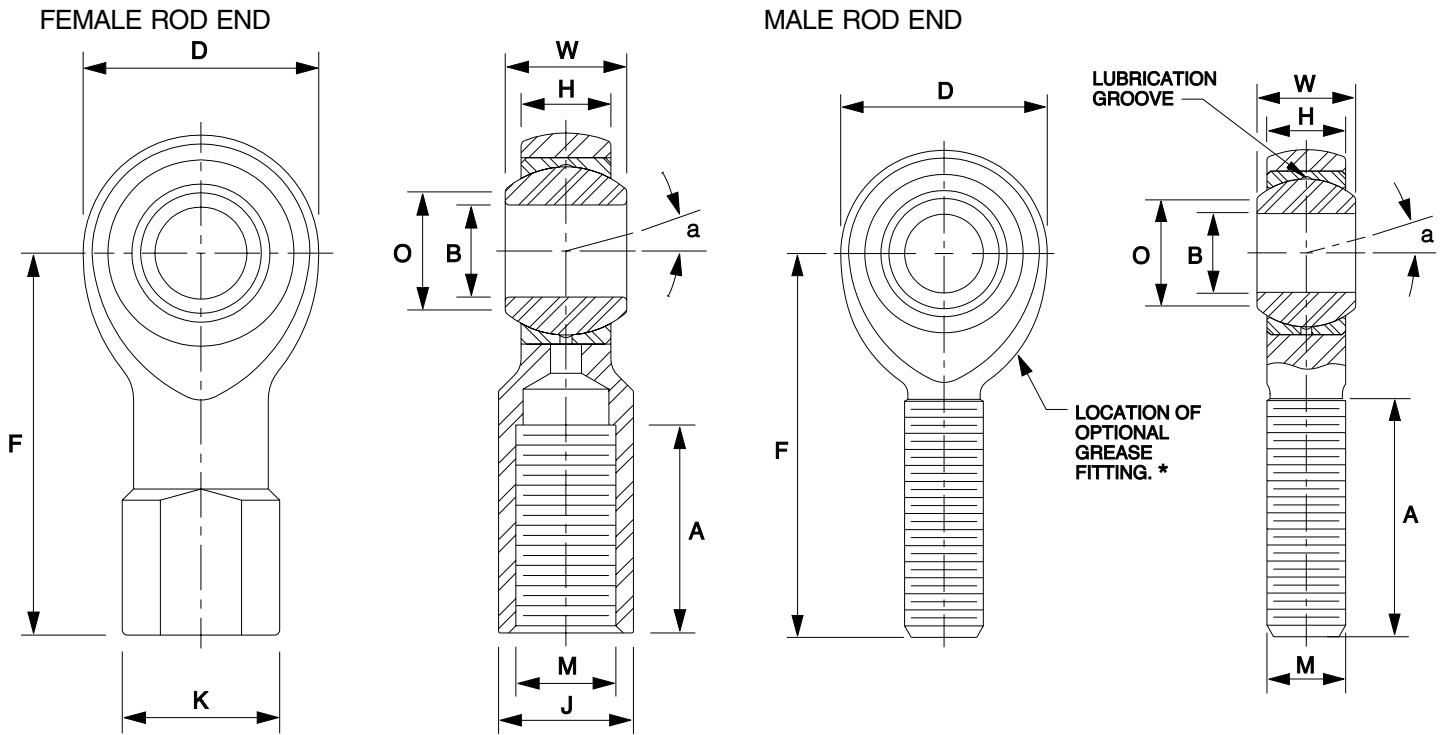

	BORE B	BALL WIDTH W	HOUSING WIDTH H	HEAD DIA. D	LENGTH TO CTR. OF BALL F	THREAD LENGTH A	THREAD SIZE M	BASE DIA. K	ACROSS WRENCH FLATS J	BALL DIA. O	BALL FLAT DIA. O	MIS- ALIGN- MENT ANGLE a
MALE												
FEMALE												

## SPHERICAL BEARING

## SKETCH OR ADDITIONAL INFORMATION

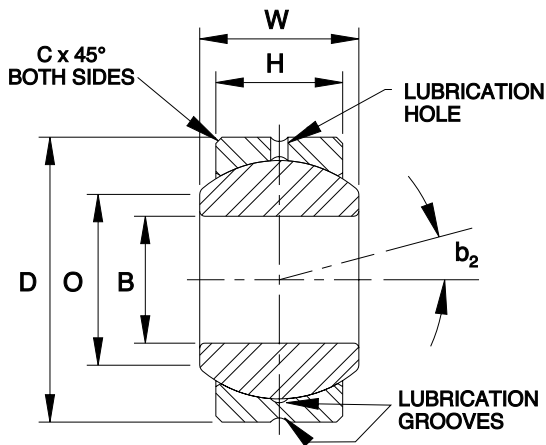

BORE B	CHAMFER C REF	OUTSIDE DIA. D	BALL WIDTH W	RACE WIDTH H	BALL DIA.	BALL FLAT DIA. O	MIS- ALIGN- MENT ANGLE b <sub>2</sub>