

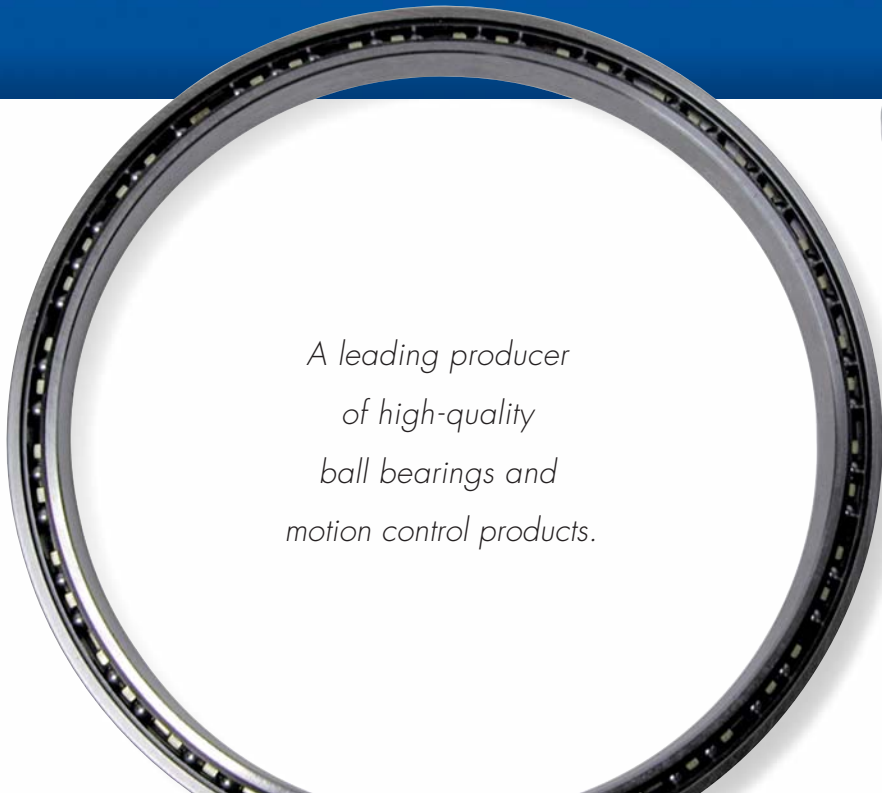

Schatz Bearing Corporation® AIRCRAFT APPLICATIONS



*A leading producer  
of high-quality  
ball bearings and  
motion control products.*



Control Ball Bearings  
Precision Ball Bearings  
Custom Ball Bearings

**Call Toll Free  
800.554.1403  
or visit  
[www.SchatzBearing.com](http://www.SchatzBearing.com)**

# SCHATZ BEARING CORPORATION



Schatz Bearing Corporation is a leading producer of high-quality ball bearings and motion control products. The Schatz name has been associated with quality and innovation for nearly a century. Our products are used in demanding applications in numerous industries including Aerospace, Machine Tool, Automation and Robotics, Medical Equipment, and Semiconductor Manufacturing Equipment.

Schatz products are manufactured in our AS9100 certified and ISO 9001 certified facility in Poughkeepsie, New York. Our product lines cover a broad range of ball bearing designs:

- Commercial Ball Bearings
- Aircraft Control Bearings
- Linear Motion Guide Wheels, Components, and Systems
- Thin Section Ball Bearings

Our experience and expertise has helped numerous customers solve problems using special bearing designs suited to their specific applications. Our long history allows us to call on previous designs to expeditiously design and develop special bearings to solve problems in demanding applications. Schatz manufactures most types of commercially available ball bearing designs, including radial ball bearings, angular contact bearings, double-row angular contact bearings, duplex angular contact bearings, four point contact bearings, and thrust bearings.

Please contact us for further assistance:

Schatz Bearing Corporation  
10 Fairview Avenue  
Poughkeepsie, New York 12601  
Tel: 845.452.6000  
Fax: 845.452.1660  
[www.schatzbearing.com](http://www.schatzbearing.com)



## SCHATZ BEARING CORPORATION

*A leading producer of high-quality ball bearings and motion control products.*

10 Fairview Avenue, Poughkeepsie, New York 12601  
Tel: 845.452.6000 • [schatzbearing.com](http://schatzbearing.com) • Fax: 845.452.1660



# TABLE OF CONTENTS

Schatz Aircraft Control Bearings, Standard Series/Precision Series

## SCHATZ PRECISION BEARINGS

Precision Series Part Numbering System	p. 2
1900 (Extremely Light) Series	p. 3
9100 (Extra Light) Series	p. 4
1200 (Light) Series	p. 5
1300 (Medium) Series	p. 6
R (Inch Boundary Dimension) Series	p. 7

## SCHATZ AIRCRAFT CONTROL BEARINGS

Aircraft Control Bearings Part Numbering System	p. 8
B500/MB500 (Extra Light Torque Tube Type) Standard Series/Precision Series	p. 9
B500DD/MB500DD (Extra Light Torque Tube Type) Standard Series/Precision Series	p.10
B5500WZZ (Double Row Torque Tube Type) Series	p.11
DPP/MDPP (Radial Type/Double Row, DF) Standard Series/Precision Series	p.12
DPP-W (Radial Type/Double Row, DB) Series	p.13
DSP/MDSP (Self-aligning Type, Double Row) Standard Series/Precision Series	p.14
DW, GDW/MDW, MGDW (Extra Wide, Double Row) Standard Series/Precision Series	p.15
FL (Fairlead) Series	p.16
K (Track Rollers) Series	p.17
KP/MKP (Radial Type) Standard Series/Precision Series	p.18
KP-A/MKP-A (Radial Type) Standard Series/Precision Series	p.19
KP-B/MKP-B (Torque Tube Type) Standard Series/Precision Series	p.20
KP-BS/MKP-BS (Self-aligning Torque Tube Type) Standard Series/Precision Series	p.21
KSP, KSP-A/MKSP, MKSP-A (Self-aligning Type) Standard Series/Precision Series	p.22
P (Pulley Type) Series	p.23

## BEARING ENGINEERING

Engineering Index	p.24
Bearing Engineering Specifications and Calculations	p.25
Lubrication Choices Table	p.28
Schatz Materials and Design Options	
Materials Options	p.29
Retainer Materials and Options	p.30
Closure Options: Seals and Shields	p.31
ABEC Tolerances Tables	p.32
Bearings for Special Applications	p.36

## SCHATZ BEARING CORPORATION

*A leading producer of high-quality ball bearings and motion control products.*

10 Fairview Avenue, Poughkeepsie, New York 12601  
Tel: 845.452.6000 • [schatzbearing.com](http://schatzbearing.com) • Fax: 845.452.1660



# SCHATZ PRECISION SERIES

Precision Series Part Numbering Descriptions

## Series

19	(1900 Series) Extremely Light
91	(9100 Series) Extra Light
12	(1200 Series) Light
13	(1300 Series) Medium
R	(R Series) Inch Boundary

## Closure Designation

—	Open Bearing
F	One Shield
FF	Two Shields
L	One Buna N Lip Seal
LL	Two Buna N Lip Seals
LT	One Teflon® Lip Seal
LLT	Two Teflon® Lip Seals

## Series

## Closure Designation

1205 LLT SS - I V I

## Material Designation

## Material Designation

—	52100
SS	440C
NS	EMS138

## Bore Size Designation

## Bore Size

00	10mm
01	12mm
02	15mm
03	17mm
04 +	is equal to the number x 5
R	(R Series) 1/16" increments

## Internal Clearance

1	Standard
2	Tight
3	Loose
4	Extra-loose

Please refer to the table on page 26 for specific measurements.

## Tolerance Class

## Tolerance Class

1	ABEC1
3	ABEC3
5	ABEC5
7	ABEC7

## Lubrication Internal Clearance

## Lubrication

B	MIL-PRF-6085
C	Special Lubricant
D	MIL-L-15719A
E	MIL-G-25013
L	MIL-PRF-23827
Q	MIL-PRF-10924
V	MIL-PRF-81322

## SCHATZ BEARING CORPORATION

A leading producer of high-quality ball bearings and motion control products.

10 Fairview Avenue, Poughkeepsie, New York 12601

Tel: 845.452.6000 • schatzbearing.com • Fax: 845.452.1660

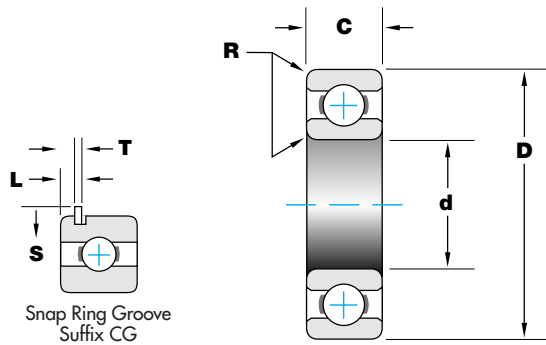

- Extremely light duty
- Single row radial
- Deep groove
- Non-filling slot bearings

Tolerances shown below are ABEC 1. For ABEC 3, 5, and 7 ratings see pages 32-35.

## 1900 SERIES BEARING DIMENSIONS AND LOAD RATINGS

Basic Bearing Dimensions in inches (mm)

Bearing Part No.	Bore		O.D.		Width C	Radius	With Snap Ring			Balls		Basic Dynamic Radial Load Rating (lbs.) C <sub>r</sub>
	d inches (mm)	+0.0000 to Minus	D inches (mm)	+0.0000 to Minus	+0.000 to -0.005 inches (mm)	R*	S	T	L	No.	Size	
1900	0.3937 (10)	.0003	0.8661 (22)	.0004	0.2362 (6)	0.012	0.984	0.026	0.066	9	1/8	610
1901	0.4724 (12)	.0003	0.9449 (24)	.0004	0.2362 (6)	0.012	1.062	0.026	0.066	9	9/64	740
1902	0.5906 (15)	.0003	1.1024 (28)	.0004	0.2756 (7)	0.012	1.203	0.031	0.081	10	5/32	970
1903	0.6693 (17)	.0003	1.1811 (30)	.0004	0.2756 (7)	0.012	1.281	0.031	0.081	11	5/32	1030
1904	0.7874 (20)	.0004	1.4567 (37)	.0005	0.3543 (9)	0.012	1.562	0.031	0.096	11	3/16	1420
1905	0.9843 (25)	.0004	1.6535 (42)	.0005	0.3543 (9)	0.012	1.750	0.031	0.096	11	7/32	1880
1906	1.1811 (30)	.0004	1.8504 (47)	.0005	0.3543 (9)	0.012	1.953	0.031	0.096	14	3/16	1620
1907	1.3780 (35)	.0005	2.1654 (55)	.0005	0.3937 (10)	0.025	2.281	0.031	0.096	14	7/32	2130
1908	1.5748 (40)	.0005	2.4409 (62)	.0005	0.4724 (12)	0.025	2.562	0.031	0.096	13	9/32	3250
1909	1.7717 (45)	.0005	2.6772 (68)	.0005	0.4724 (12)	0.025	2.797	0.031	0.096	15	17/64	3150
1910	1.9685 (50)	.0005	2.8346 (72)	.0005	0.4724 (12)	0.025	2.953	0.031	0.096	16	17/64	3240
1911	2.1654 (55)	.0006	3.1496 (80)	.0005	0.5118 (13)	0.040	3.312	0.042	0.120	17	9/32	3810
1912	2.3622 (60)	.0006	3.3465 (85)	.0006	0.5118 (13)	0.040	3.516	0.042	0.120	17	5/16	4520
1913	2.5591 (65)	.0006	3.5433 (90)	.0006	0.5118 (13)	0.040	3.703	0.042	0.120	19	9/32	3950
1914	2.7559 (70)	.0006	3.9370 (100)	.0006	0.6299 (16)	0.040	4.109	0.042	0.136	17	11/32	5290
1915	2.9528 (75)	.0006	4.1339 (105)	.0006	0.6299 (16)	0.040	4.359	0.042	0.136	17	3/8	6230
1916	3.1496 (80)	.0006	4.3307 (110)	.0006	0.6299 (16)	0.040	4.457	0.042	0.136	19	11/32	5600

\* Maximum shaft or housing radius which bearing corner will clear.

Notes: 1 Available with shields or seals.

2 Contact Schatz Bearing Corporation's Engineering Department for further technical information.

3 Check with Schatz Bearing Corporation's Sales Department for price and availability.

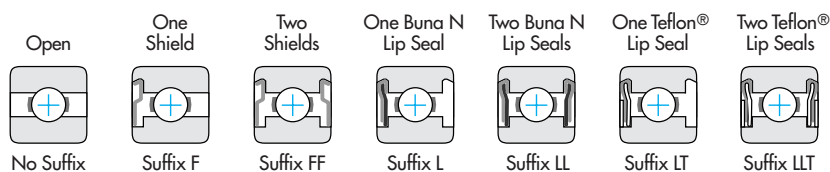

Materials Options

See page 29 for details.

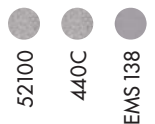

## SCHATZ BEARING CORPORATION

A leading producer of high-quality ball bearings and motion control products.

10 Fairview Avenue, Poughkeepsie, New York 12601

Tel: 845.452.6000 • schatzbearing.com • Fax: 845.452.1660

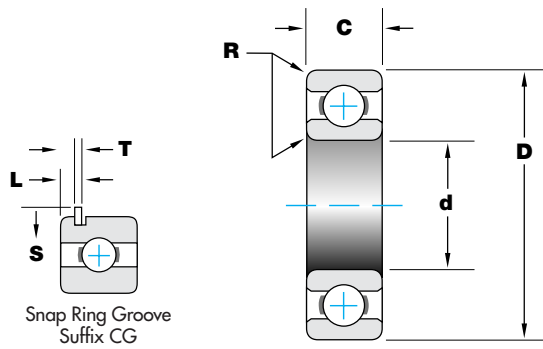

- Extra light duty
- Single row radial
- Deep groove
- Non-filling slot bearings
- Similar shield and seal options to 1900 Series

Tolerances shown below are ABEC 1. For ABEC 3, 5, and 7 ratings see pages 32-35.

## 9100 SERIES BEARING DIMENSIONS AND LOAD RATINGS

Basic Bearing Dimensions in inches (mm)

Bearing Part No.	Bore		O.D.		Width C	Radius	With Snap Ring			Balls		Basic Dynamic Radial Load Rating (lbs.) C <sub>r</sub>
	d inches (mm)	+0.000 to Minus	D inches (mm)	+0.000 to Minus	+0.000 to -0.005 inches (mm)	R*	S	T	L	No.	Size	
9100	0.3937 (10)	.0003	1.0236 (26)	.0004	0.3150 (8)	0.012	-	-	-	7	3/16	1020
9101	0.4724 (12)	.0003	1.1024 (28)	.0004	0.3150 (8)	0.012	1.203	0.031	0.081	8	3/16	1140
9102	0.5906 (15)	.0003	1.2598 (32)	.0005	0.3543 (9)	0.012	1.438	0.042	0.120	9	3/16	1250
9103	0.6693 (17)	.0003	1.3780 (35)	.0005	0.3937 (10)	0.012	1.547	0.042	0.120	10	3/16	1340
9104	0.7874 (20)	.0003	1.6535 (42)	.0005	0.4724 (12)	0.025	1.812	0.042	0.120	9	1/4	2090
9105	0.9843 (25)	.0003	1.8504 (47)	.0005	0.4724 (12)	0.025	2.062	0.042	0.120	10	1/4	2250
9106	1.1811 (30)	.0003	2.1654 (55)	.0005	0.5118 (13)	0.040	2.375	0.042	0.120	11	9/32	2950
9107	1.3780 (35)	.0003	2.4409 (62)	.0005	0.5512 (14)	0.040	2.656	0.065	0.143	11	5/16	3570
9108	1.5748 (40)	.0003	2.6772 (68)	.0005	0.5906 (15)	0.040	2.922	0.065	0.159	13	5/16	3950
9109	1.7717 (45)	.0003	2.9528 (75)	.0005	0.6299 (16)	0.040	3.203	0.065	0.159	13	11/32	4860
9110	1.9685 (50)	.0003	3.1496 (80)	.0005	0.6299 (16)	0.040	3.406	0.065	0.159	13	3/8	5480
9111	2.1654 (55)	.0006	3.5433 (90)	.0006	0.7087 (18)	0.040	3.797	0.095	0.204	13	13/32	6310
9112	2.3622 (60)	.0006	3.7402 (95)	.0006	0.7087 (18)	0.040	3.984	0.095	0.204	13	7/16	7210
9113	2.5591 (65)	.0006	3.9370 (100)	.0006	0.7087 (18)	0.040	4.188	0.095	0.204	14	7/16	7520
9114	2.7559 (70)	.0006	4.3307 (110)	.0006	0.7874 (20)	0.040	4.578	0.095	0.204	13	1/2	9160
9115	2.9528 (75)	.0006	4.5276 (115)	.0006	0.7874 (20)	0.040	4.781	0.095	0.204	14	1/2	9550
9116	3.1496 (80)	.0006	4.9213 (125)	.0008	0.8661 (22)	0.040	5.297	0.109	0.218	14	17/32	10630
9117	3.3465 (85)	.0008	5.1181 (130)	.0008	0.8661 (22)	0.040	5.500	0.109	0.218	14	9/16	11800
9118	3.5433 (90)	.0008	5.5118 (140)	.0008	0.9449 (24)	0.060	5.891	0.109	0.250	14	19/32	12360
9119	3.7402 (95)	.0008	5.7087 (145)	.0008	0.9449 (24)	0.060	6.078	0.109	0.250	14	5/8	14250
9120	3.9370 (100)	.0008	5.9055 (150)	.0008	0.9449 (24)	0.060	6.281	0.109	0.250	14	21/32	15580
9121	4.1339 (105)	.0008	6.2992 (160)	.0010	1.0236 (26)	0.080	6.2672	0.109	0.250	14	11/16	16910
9122	4.3307 (110)	.0008	6.6929 (170)	.0010	1.1024 (28)	0.080	7.188	0.120	0.261	13	3/4	18910
9124	4.7244 (120)	.0008	7.0866 (180)	.0010	1.1024 (28)	0.080	7.594	0.120	0.261	14	3/4	19670
9126	5.1181 (130)	.0010	7.8740 (200)	.0012	1.2992 (33)	0.080	8.8375	0.120	0.339	14	13/16	21600

\* Maximum shaft or housing radius which bearing corner will clear.

- Notes: 1 Available with shields or seals.  
 2 Contact Schatz Bearing Corporation's Engineering Department for further technical information.  
 3 Check with Schatz Bearing Corporation's Sales Department for price and availability.  
 4 For seal options please look to the diagram to the immediate right on page 5.

Materials Options

See page 29 for details.

52100

440C

EMS 138

## SCHATZ BEARING CORPORATION

A leading producer of high-quality ball bearings and motion control products.

10 Fairview Avenue, Poughkeepsie, New York 12601

Tel: 845.452.6000 • schatzbearing.com • Fax: 845.452.1660



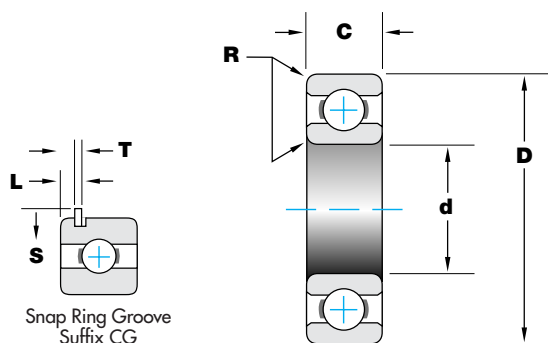

- Light duty
- Single row radial
- Deep groove
- Non-filling slot bearings

Tolerances shown below are ABEC 1. For ABEC 3, 5, and 7 ratings see pages 32-35.

## 1200 SERIES BEARING DIMENSIONS AND LOAD RATINGS

Basic Bearing Dimensions in inches (mm)

Bearing Part No.	Bore		O.D.		Width C	Radius	With Snap Ring			Balls		Basic Dynamic Radial Load Rating (lbs.) C <sub>r</sub>
	d inches (mm)	+0.0000 to Minus	D inches (mm)	+0.0000 to Minus	+0.000 to -0.005 inches (mm)	R*	S	T	L	No.	Size	
<b>1200</b>	0.3937 (10)	.0003	1.1811 (30)	.0004	0.3543 (9)	0.025	1.359	0.042	0.120	7	7/32	1330
<b>1201</b>	0.4724 (12)	.0003	1.2598 (32)	.0005	0.3937 (10)	0.025	1.438	0.042	0.120	7	15/64	1520
<b>1202</b>	0.5906 (15)	.0003	1.3780 (35)	.0005	0.4331 (11)	0.025	1.547	0.042	0.120	8	7/32	1510
<b>1203</b>	0.6693 (17)	.0003	1.5748 (40)	.0005	0.4724 (12)	0.025	1.750	0.042	0.120	8	17/64	2130
<b>1204</b>	0.7874 (20)	.0004	1.8504 (47)	.0005	0.5512 (14)	0.040	2.062	0.042	0.136	8	5/16	2850
<b>1205</b>	0.9843 (25)	.0004	2.0472 (52)	.0005	0.5906 (15)	0.040	2.266	0.042	0.136	9	5/16	3130
<b>1206</b>	1.1811 (30)	.0004	2.4409 (62)	.0005	0.6299 (16)	0.040	2.656	0.065	0.190	9	13/32	4980
<b>1207</b>	1.3780 (35)	.0005	2.8346 (72)	.0005	0.6693 (17)	0.040	3.078	0.065	0.190	9	7/16	5820
<b>1208</b>	1.5748 (40)	.0005	3.1496 (80)	.0005	0.7087 (18)	0.040	3.406	0.065	0.190	9	1/2	7280
<b>1209</b>	1.7717 (45)	.0005	3.3465 (85)	.0006	0.7480 (19)	0.040	3.594	0.065	0.190	10	1/2	7830
<b>1210</b>	1.9685 (50)	.0005	3.5433 (90)	.0006	0.7874 (20)	0.040	3.797	0.095	0.220	10	1/2	7830
<b>1211</b>	2.1654 (55)	.0006	3.9370 (100)	.0006	0.8268 (21)	0.060	4.188	0.095	0.220	10	9/16	9680
<b>1212</b>	2.3622 (60)	.0006	4.3307 (110)	.0006	0.8661 (22)	0.060	4.578	0.095	0.220	10	9/16	9680
<b>1213</b>	2.5591 (65)	.0006	4.7244 (120)	.0006	0.9055 (23)	0.060	5.094	0.109	0.265	10	21/32	12770
<b>1214</b>	2.7559 (79)	.0006	4.9213 (125)	.0008	0.9449 (24)	0.060	5.297	0.109	0.265	10	11/16	13890
<b>1215</b>	2.9528 (75)	.0006	5.1181 (130)	.0008	0.9843 (25)	0.060	5.500	0.109	0.265	11	11/16	14770

\* Maximum shaft or housing radius which bearing corner will clear.

Notes: 1 Available with shields or seals.

2 Contact Schatz Bearing Corporation's Engineering Department for further technical information.

3 Check with Schatz Bearing Corporation's Sales Department for price and availability.

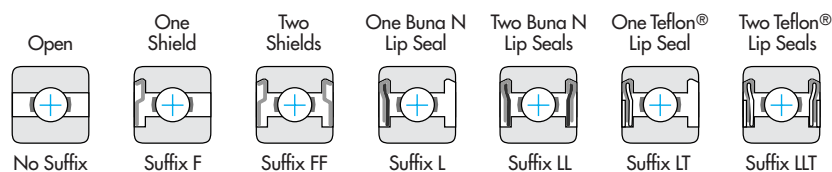

Materials Options

See page 29 for details.

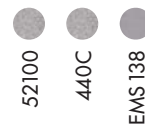

## SCHATZ BEARING CORPORATION

A leading producer of high-quality ball bearings and motion control products.

10 Fairview Avenue, Poughkeepsie, New York 12601

Tel: 845.452.6000 • schatzbearing.com • Fax: 845.452.1660

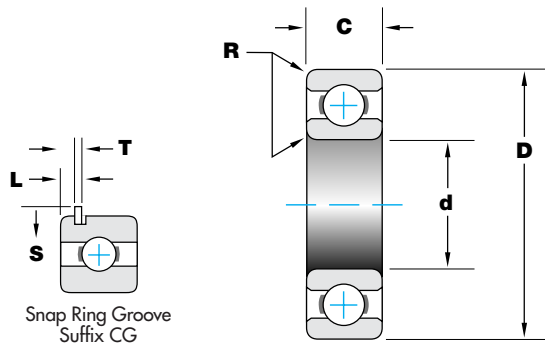

- Medium duty
- Single row radial
- Deep groove
- Non-filling slot bearings

Tolerances shown below are ABEC 1. For ABEC 3, 5, and 7 ratings see pages 32-35.

## 1300 SERIES BEARING DIMENSIONS AND LOAD RATINGS

Basic Bearing Dimensions in inches (mm)

Bearing Part No.	Bore		O.D.		Width C + .000 to -.005 inches (mm)	Radius R*	With Snap Ring			Balls		Basic Dynamic Radial Load Rating (lbs.) C <sub>r</sub>
	d inches (mm)	+ .0000 to Minus	D inches (mm)	+ .0000 to Minus			S	T	L	No.	Size	
<b>1300</b>	0.3937 (10)	.0003	1.3780 (35)	.0005	0.4331 (11)	0.025	1.547	0.042	0.120	6	9/32	1920
<b>1301</b>	0.4724 (12)	.0003	1.4567 (37)	.0005	0.4724 (12)	0.040	1.609	0.042	0.120	6	5/16	2170
<b>1302</b>	0.5906 (15)	.0003	1.6535 (42)	.0005	0.5118 (13)	0.040	1.812	0.042	0.120	6	11/32	2620
<b>1303</b>	0.6693 (17)	.0003	1.8504 (47)	.0005	0.5512 (14)	0.040	2.062	0.042	0.136	6	3/8	3100
<b>1304</b>	0.7874 (20)	.0004	2.0472 (52)	.0005	0.5906 (15)	0.040	2.266	0.042	0.136	7	13/32	4020
<b>1305</b>	0.9843 (25)	.0004	2.4409 (62)	.0005	0.6693 (17)	0.040	2.656	0.065	0.190	7	15/32	5270
<b>1306</b>	1.1811 (30)	.0004	2.8346 (72)	.0005	0.7480 (19)	0.040	3.078	0.065	0.190	8	1/2	6600
<b>1307</b>	1.3780 (35)	.0005	3.1496 (80)	.0005	0.8268 (21)	0.060	3.406	0.065	0.190	8	9/16	8160
<b>1308</b>	1.5748 (40)	.0005	3.5433 (90)	.0006	0.9055 (23)	0.060	3.797	0.095	0.220	8	5/8	9890
<b>1309</b>	1.7717 (45)	.0005	3.9370 (100)	.0006	0.9843 (25)	0.060	4.188	0.095	0.220	8	11/16	11770
<b>1310</b>	1.9685 (50)	.0005	4.3307 (110)	.0006	1.0630 (27)	0.080	4.578	0.095	0.220	8	11/16	11770
<b>1311</b>	2.1654 (55)	.0006	4.7244 (120)	.0006	1.1417 (29)	0.080	5.094	0.109	0.265	8	13/16	15950
<b>1312</b>	2.3622 (60)	.0006	5.1181 (130)	.0008	1.2205 (31)	0.080	5.500	0.109	0.265	8	7/8	18240
<b>1313</b>	2.5591 (65)	.0006	5.5118 (140)	.0008	1.2992 (33)	0.080	5.891	0.109	0.297	8	15/16	20670
<b>1314</b>	2.7559 (70)	.0006	5.9055 (150)	.0008	1.3780 (35)	0.080	6.281	0.109	0.297	8	1	23240

\* Maximum shaft or housing radius which bearing corner will clear.

Notes: 1 Available with shields or seals.

2 Contact Schatz Bearing Corporation's Engineering Department for further technical information.

3 Check with Schatz Bearing Corporation's Sales Department for price and availability.

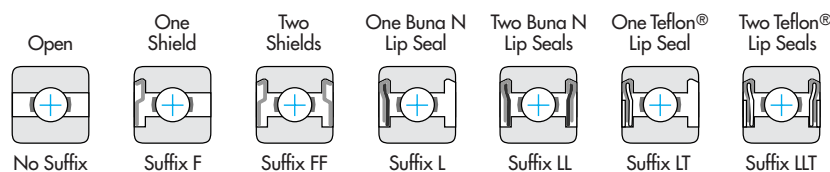

Materials Options

See page 29 for details.

- 52100
- 440C
- EMS 138

## SCHATZ BEARING CORPORATION

A leading producer of high-quality ball bearings and motion control products.

10 Fairview Avenue, Poughkeepsie, New York 12601

Tel: 845.452.6000 • schatzbearing.com • Fax: 845.452.1660



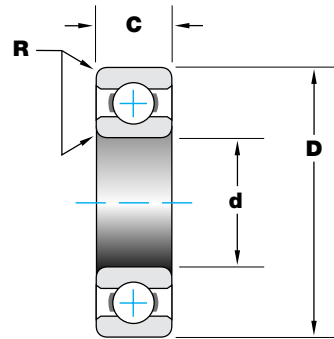

- Inch boundary dimensions
- Single row radial
- Deep groove
- Non-filling slot bearings

Tolerances shown below are ABEC 1. For ABEC 3, 5, and 7 ratings see pages 32-35.

## R SERIES BEARING DIMENSIONS AND LOAD RATINGS

Basic Bearing Dimensions in inches (mm)

Bearing Part Number	Bore		O.D.		Width: C +.000 to -.005 (inches)		Radius	Balls		Basic Dynamic Radial Load Rating (lbs.) C <sub>r</sub>
	d (inches)	+0.000 to Minus	D (inches)	+0.000 to Minus	Open	Shielded or Sealed	R* (inches)	No.	Size	
<b>R2</b>	0.1250	0.0003	0.3750	0.0004	0.1562	0.1562	0.012	7	1/16	140
<b>R2A</b>	0.1250	0.0003	0.5000	0.0004	0.1719	0.1719	0.012	7	1/16	140
<b>R3</b>	0.1875	0.0003	0.5000	0.0004	0.1562	0.1960	0.012	7	3/32	290
<b>R4</b>	0.2500	0.0003	0.6250	0.0004	0.1960	0.1960	0.012	7	1/8	480
<b>R4A</b>	0.2500	0.0003	0.7500	0.0004	0.2188	0.2812	0.016	6	5/32	630
<b>R6</b>	0.3750	0.0003	0.8750	0.0004	0.2188	0.2812	0.016	7	5/32	820
<b>R8</b>	0.5000	0.0003	1.1250	0.0004	0.2500	0.3125	0.016	8	3/16	1140
<b>R10</b>	0.6250	0.0003	1.3750	0.0005	0.2812	0.3438	0.031	8	7/32	1520
<b>R12</b>	0.7500	0.0004	1.6250	0.0005	0.3125	0.4375	0.031	9	1/4	2090
<b>R14</b>	0.8750	0.0004	1.8750	0.0005	0.3750	0.5000	0.031	9	9/32	2590
<b>R16</b>	1.0000	0.0004	2.0000	0.0005	0.3750	0.5000	0.031	10	9/32	2780
<b>R18</b>	1.1250	0.0004	2.1250	0.0005	0.3750	0.5000	0.031	11	9/32	2960
<b>R20</b>	1.2500	0.0005	2.2500	0.0005	0.3750	0.5000	0.031	12	9/32	3120
<b>R22</b>	1.3750	0.0005	2.5000	0.0005	0.4375	0.5625	0.031	11	5/16	3560
<b>R24</b>	1.5000	0.0005	2.6250	0.0005	0.4375	0.5625	0.031	12	5/16	3750

\* Maximum shaft or housing radius which bearing corner will clear.

Notes: 1 Available with shields or seals.

2 Contact Schatz Bearing Corporation's Engineering Department for further technical information.

3 Check with Schatz Bearing Corporation's Sales Department for price and availability.

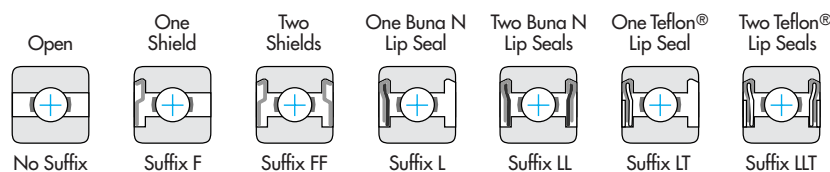

Materials Options

See page 29  
for details.

- 52100
- 440C
- EMS 138

## SCHATZ BEARING CORPORATION

A leading producer of high-quality ball bearings and motion control products.

10 Fairview Avenue, Poughkeepsie, New York 12601

Tel: 845.452.6000 • schatzbearing.com • Fax: 845.452.1660



# AIRCRAFT CONTROL BEARINGS

Schatz Precision Series Part Numbering Descriptions

Many of the Schatz Aircraft Control Bearings are manufactured and approved to the applicable SAE and U.S. Government military standards, controlled by AS7949. The following is a list of Schatz series and the corresponding MS series designation.

This table is a list of the Schatz approvals to the AS7949 series as of the publication of this catalog. Please consult the Schatz website at [www.schatzbearing.com](http://www.schatzbearing.com) for an updated listing of these approvals.

AS7949 Series	Schatz Series	Description	Catalog Page
<b>AS21428</b>	<b>MB500DD</b>	Extra Light Torque Tube, Precision	10
<b>AS21443</b>	<b>Pulley</b>	Pulley Type	22
<b>AS27640</b>	<b>KP</b>	Heavy Duty	17
<b>AS27641</b>	<b>KP-A</b>	Intermediate Duty	18
<b>AS27643</b>	<b>DSP</b>	Heavy Duty, Self-Aligning	23
<b>AS27644</b>	<b>DPP</b>	Extra Heavy Duty, Double Row	12
<b>AS27645</b>	<b>KSP</b>	Self-Aligning	19
<b>AS27646</b>	<b>B500DD</b>	Extra Light Torque Tube	10
<b>AS27647</b>	<b>DW, GDW</b>	Heavy Duty, Extra Wide, Double Row	14
<b>AS27648</b>	<b>KP-BS</b>	Extra Light Duty, Torque Tube, Self-Aligning	21

*This list is based upon current approvals as of the printing of this catalog. Please check with Schatz Engineering for any updates to our approval listing.*

## Grease specification

Bearings with a suffix –H are packed with grease that is approved to MIL-PRF-81322. Bearings with a –L are packed with grease that is approved to MIL-PRF-23827. Additionally, many other lubricants are available. Please see the engineering section for an additional listing of the available lubricants.

## Bearing modifications

Many of the Schatz Aircraft Control series can be manufactured with modified designs to suit application requirements. Examples of these modifications follow:

### Corrosion-resistant materials

Schatz manufactures many of these bearing series in 440C corrosion resistant steel. Additionally, many of these series can be manufactured utilizing Schatz specification EMS138 which utilizes a high corrosion resistant and high fatigue resistant steel. (Consult page 29 of the Engineering Section for further details)

### Higher precision level

Many of these series are offered in compliance to higher precision levels.

### Low starting torque

Schatz can modify the seal, grease, separator, and ball complement on many of the bearings to offer a lower starting torque than the standard series offers.

### Angular contact bearings and duplex sets

Schatz can manufacture some of the series in angular contact versions that can be mounted as single bearings or in pairs as a duplex set for increased axial capacity and rigidity.

## SCHATZ BEARING CORPORATION

*A leading producer of high-quality ball bearings and motion control products.*

10 Fairview Avenue, Poughkeepsie, New York 12601

Tel: 845.452.6000 • [schatzbearing.com](http://schatzbearing.com) • Fax: 845.452.1660

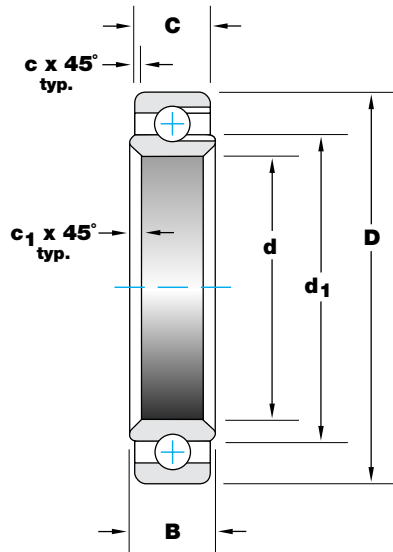

- Extra light duty
- Single row, ball
- Open type
- Lubricated with a preservative

### MB500 SERIES

- Precision Series **tolerances in gray**

When ordering precision parts be sure to add the "M" prefix to the standard part number.

## B500/MB500 SERIES BEARING DIMENSIONS AND LOAD RATINGS

Bearing Part Number	Basic Bearing Dimensions (inches)								Load Ratings (lbs.) †			
	Bore d		O.D. D		Width			d <sub>1</sub>	c <sub>1</sub>	c	Radial Limit	Thrust Limit
	+0.0007 -0.0007	+0.0000 -0.0005	+0.0000 -0.0010	+0.0000 -0.0005	B +0.000 -0.005	C +0.000 -0.005	+0.000 -0.005	Minimum	Chamfer*	Chamfer*		
<b>B538</b>	0.6250		1.0625		0.281	0.250		0.777	0.015	0.015	3280	1500
<b>B539</b>	0.7500		1.1875		0.281	0.250		0.895	0.015	0.015	3750	1700
<b>B540</b>	0.8750		1.3125		0.281	0.250		1.016	0.015	0.015	4220	1900
<b>B541</b>	1.0625		1.5000		0.281	0.250		1.216	0.015	0.015	5000	2200
<b>B542</b>	1.3125		1.7500		0.281	0.250		1.451	0.015	0.015	5950	2700
<b>B543</b>	1.5625		2.0000		0.281	0.250		1.702	0.015	0.015	6880	3200
<b>B544</b>	1.8125**		2.2500***		0.281	0.250		1.970	0.015	0.015	7980	3600
<b>B545</b>	2.0625**		2.6250***		0.281	0.250		2.286	0.015	0.015	9220	4000
<b>B546</b>	2.3125**		2.8750***		0.281	0.250		2.527	0.015	0.015	10150	4400

\* Maximum shaft or housing radius which bearing corner will clear.

† Refer to p.27 for details.

\*\* +.0010 inch/-0.0010 inch

+0.0010 inch/-0.0008 inch

\*\*\* +.0000 inch/-0.0015 inch

+0.0000 inch/-0.0007 inch

- Notes: 1 Do not use bearings as track rollers, cam follower rolls or for similar applications.  
 2 Check with Schatz Bearing Corporation for current approval status.  
 3 Contact Schatz Bearing Corporation's Engineering Department for further technical information.  
 4 Check with Schatz Bearing Corporation's Sales Department for price and availability.

#### Materials Options

See page 29  
for details.

- 52100
- 440C
- EMS 138

## SCHATZ BEARING CORPORATION

A leading producer of high-quality ball bearings and motion control products.

10 Fairview Avenue, Poughkeepsie, New York 12601

Tel: 845.452.6000 • schatzbearing.com • Fax: 845.452.1660

# B500DD/MB500DD SERIES

Schatz Extra Light, Torque Tube Type, Aircraft Control Bearings, Standard Series/Precision Series

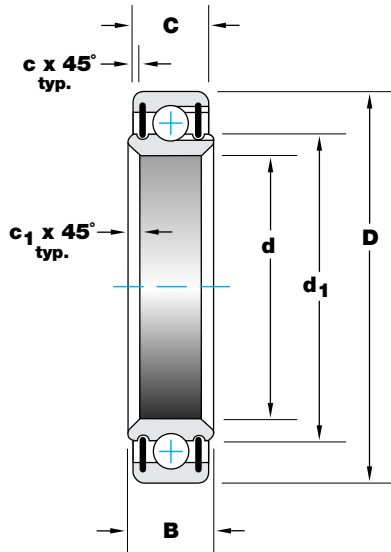

- Manufactured to AS27646 per SAE AS7949
- Extra light duty
- Single row, ball
- Teflon® coated fiberglass seals
- All external surfaces except bore and seals are cadmium plated.
- Pre-lubricated (see page 8 for grease specifications.)
- This series is dimensionally interchangeable with the unshielded B500 series.

## MB500DD SERIES

- Precision Series **tolerances in gray**
  - Manufactured to AS21428 per SAE AS7949
- When ordering precision parts be sure to add the "M" prefix to the standard part number.

## B500DD/MB500DD SERIES BEARING DIMENSIONS AND LOAD RATINGS

Bearing Part Number	MS 27646-	Basic Bearing Dimensions (inches)								Load Ratings (lbs.) †				
		Bore d		O.D. D		Width				d <sub>1</sub> Approx.	c <sub>1</sub> Chamfer*	c Chamfer*	Radial Limit	Thrust Limit
		+0.0007 -0.0007	+0.0000 -0.0005	+0.0000 -0.0010	+0.0000 -0.0005	+0.000 -0.005	+0.0000 -0.0025	+0.000 -0.005	+0.000 -0.005					
<b>B538DD</b>	<b>-38</b>	0.6250	1.0625	0.281	0.250	0.777	0.015	0.015	3280	1500				
<b>B539DD</b>	<b>-39</b>	0.7500	1.1875	0.281	0.250	0.895	0.015	0.015	3750	1700				
<b>B540DD</b>	<b>-40</b>	0.8750	1.3125	0.281	0.250	1.016	0.015	0.015	4220	1700				
<b>B541DD</b>	<b>-41</b>	1.0625	1.5000	0.281	0.250	1.216	0.015	0.015	5000	2200				
<b>B542DD</b>	<b>-42</b>	1.3125	1.7500	0.281	0.250	1.451	0.015	0.015	5950	2700				
<b>B543DD</b>	<b>-43</b>	1.5625	2.0000	0.281	0.250	1.702	0.015	0.015	6880	3200				
<b>B544DD</b>	<b>-44</b>	1.8125**	2.2500***	0.281	0.250	1.970	0.015	0.015	7980	3600				
<b>B545DD</b>	<b>-45</b>	2.0625**	2.6250***	0.281	0.250	2.286	0.015	0.015	9220	4000				
<b>B546DD</b>	<b>-46</b>	2.3125**	2.8750***	0.281	0.250	2.527	0.015	0.015	10150	4400				

\* Maximum shaft or housing radius which bearing corner will clear.

† Refer to p.27 for details.

\*\* +.0010 inch/-0.0010 inch    +.0010 inch/-0.0008 inch  
 \*\*\* +.0000 inch/-0.0015 inch    +.0000 inch/-0.0007 inch

- Notes: 1 Do not use bearings as track rollers, cam follower rolls or for similar applications.  
 2 Check with Schatz Bearing Corporation for current approval status.  
 3 Contact Schatz Bearing Corporation's Engineering Department for further technical information.  
 4 Check with Schatz Bearing Corporation's Sales Department for price and availability.

Materials Options

See page 29  
for details.

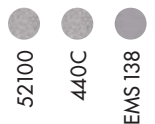

## SCHATZ BEARING CORPORATION

A leading producer of high-quality ball bearings and motion control products.

10 Fairview Avenue, Poughkeepsie, New York 12601

Tel: 845.452.6000 • schatzbearing.com • Fax: 845.452.1660

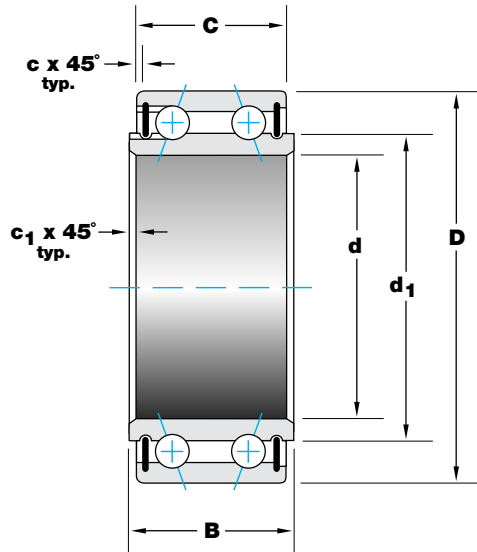

- Extra light duty
- Double row, ball
- Teflon® coated fiberglass seals
- All external surfaces except bore and seals are cadmium plated.
- Pre-lubricated (see page 8 for grease specifications.)

## B5500WZZ SERIES BEARING DIMENSIONS AND LOAD RATINGS

Bearing Part Number	Basic Bearing Dimensions (inches)							Load Ratings (lbs.) †	
	Bore d	O.D. D	Width		d <sub>1</sub>	c <sub>1</sub>	c	Radial Limit	Thrust Limit
	+0.0000 -0.0005	+0.0000 -0.0005	+0.000 -0.005	+0.000 -0.005	Minimum	Chamfer*	Chamfer*		
<b>B5538WZZ</b>	0.6250	1.0625	0.562	0.500	0.745	0.015	0.015	6250	2060
<b>B5539WZZ</b>	0.7500	1.1875	0.562	0.500	0.865	0.015	0.015	7190	2370
<b>B5540WZZ</b>	0.8750	1.3125	0.562	0.500	0.989	0.015	0.015	8120	2680
<b>B5541WZZ</b>	1.0625	1.5000	0.562	0.500	1.190	0.015	0.015	9690	3200
<b>B5542WZZ</b>	1.3125	1.7500	0.562	0.500	1.430	0.015	0.015	11600	3820
<b>B5543WZZ</b>	1.5625	2.0000	0.562	0.500	1.665	0.015	0.015	13400	4430
<b>B5544WZZ</b>	1.8125**	2.2500***	0.562	0.500	1.935	0.015	0.015	15600	5160
<b>B5545WZZ</b>	2.0625**	2.6250***	0.562	0.500	2.265	0.015	0.015	18100	5980
<b>B5546WZZ</b>	2.3125**	2.8750***	0.562	0.500	2.505	0.015	0.015	20000	6600

\* Maximum shaft or housing radius which bearing corner will clear.

\*\* +.0000 inch/-0.0008 inch

\*\*\* +.0000 inch/-0.0007 inch

† Refer to p.27 for details.

- Notes: 1 Do not use bearings as track rollers, cam follower rolls or for similar applications.  
 2 Check with Schatz Bearing Corporation for current approval status.  
 3 Contact Schatz Bearing Corporation's Engineering Department for further technical information.  
 4 Check with Schatz Bearing Corporation's Sales Department for price and availability.

Materials Options

See page 29  
for details.

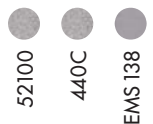

**SCHATZ BEARING CORPORATION**  
A leading producer of high-quality ball bearings and motion control products.

10 Fairview Avenue, Poughkeepsie, New York 12601  
Tel: 845.452.6000 • schatzbearing.com • Fax: 845.452.1660

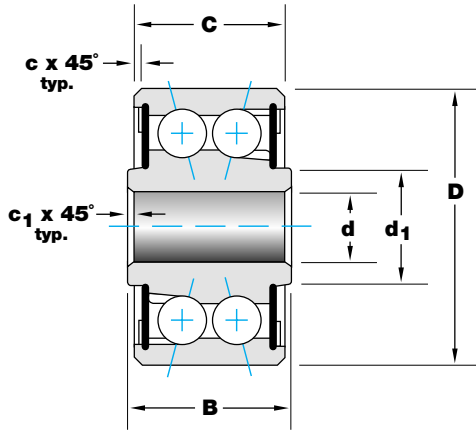

- Manufactured to AS27644 per SAE AS7949
- Double row, ball
- All external surfaces except bore, seals, and stainless steel seal retainers are cadmium plated.
- Installed with Teflon® seals
- Pre-lubricated (see page 8 for grease specifications.)

### MDPP SERIES

- Precision Series **tolerances in gray**

When ordering precision parts be sure to add the "M" prefix to the standard part number.

## DPP/MDPP SERIES BEARING DIMENSIONS AND LOAD RATINGS

Bearing Part Number	MS 27644-	Basic Bearing Dimensions (inches)								Load Ratings (lbs.) †			
		Bore d		O.D. D		Width B		C	d <sub>1</sub>	c <sub>1</sub>	c	Radial Limit	Thrust Limit
		+0.000 -0.0005	+0.000 -0.0003	+0.000 -0.0005	+0.000 -0.0004	+0.000 -0.0005	+0.000 -0.0025						
<b>DPP3</b>	<b>-3</b>	0.1900	0.7774	0.495	0.473	0.302	0.005	0.018	2950	1700			
<b>DPP4</b>	<b>-4</b>	0.2500	0.9014	0.620	0.491	0.410	0.005	0.032	5370	1800			
<b>DPP5</b>	<b>-5</b>	0.3125	1.2500	0.745	0.687	0.469	0.015	0.032	11000	4000			
<b>DPP6</b>	<b>-6*</b>	0.3750	1.4375	0.870	0.794	0.551	0.015	0.032	15760	5300			
<b>DPP8</b>	<b>-8*</b>	0.5000	1.6875	0.932	0.856	0.735	0.015	0.044	23600	7800			
<b>DPP10</b>	<b>-10*</b>	0.6250	1.9375	0.995	0.920	0.890	0.015	0.044	28400	9400			

\* Refer to QLP-AS7949 for current approval status.

† Refer to p.27 for details.

- Notes: 1 Do not use bearings as track rollers, cam follower rolls or for similar applications.  
 2 Check with Schatz Bearing Corporation for current approval status.  
 3 Contact Schatz Bearing Corporation's Engineering Department for further technical information.  
 4 Check with Schatz Bearing Corporation's Sales Department for price and availability.

#### Materials Options

See page 29 for details.

- 52100
- 440C
- EMS 138

## SCHATZ BEARING CORPORATION

A leading producer of high-quality ball bearings and motion control products.

10 Fairview Avenue, Poughkeepsie, New York 12601

Tel: 845.452.6000 • schatzbearing.com • Fax: 845.452.1660



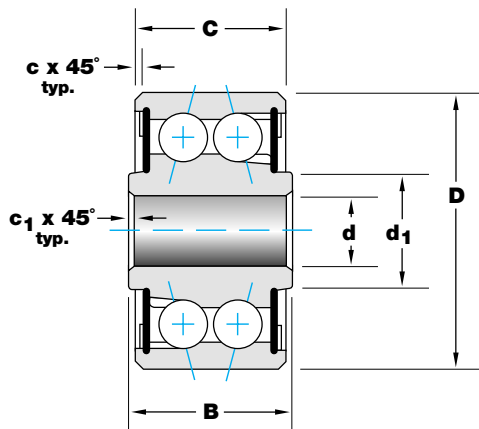

- Double row, ball
- All external surfaces except bore, seals, and stainless steel seal retainers are cadmium plated.
- Installed with Teflon® seals
- Pre-lubricated (see page 8 for grease specifications.)
- Designed for applications requiring high movement rigidity

## DPP-W SERIES BEARING DIMENSIONS AND LOAD RATINGS

Bearing Part Number	Basic Bearing Dimensions (inches)							Load Ratings (lbs.) †	
	Bore d	O.D. D	Width		d <sub>1</sub> Approx.	c <sub>1</sub> +.015 -.000	c +.015 -.000	Radial Limit	Thrust Limit
	+ .0000 - .0005	+ .0000 - .0005	B +.000 -.005	C +.000 -.005					
<b>DPP3W</b>	0.1900	0.7774	0.495	0.473	0.297	0.005	0.018	2950	1450
<b>DPP4W</b>	0.2500	0.9014	0.620	0.491	0.405	0.005	0.032	5370	1800
<b>DPP5W</b>	0.3125	1.2500	0.745	0.687	0.548	0.015	0.032	11000	4000
<b>DPP6W</b>	0.3750	1.4375	0.870	0.794	0.603	0.015	0.032	15760	5300
<b>DPP8W</b>	0.5000	1.6875	0.932	0.856	0.730	0.015	0.044	23600	7800
<b>DPP10W</b>	0.6250	1.9375	0.995	0.920	0.945	0.015	0.044	28400	9400

- Notes: 1 Do not use bearings as track rollers, cam follower rolls or for similar applications.  
 2 Check with Schatz Bearing Corporation for current approval status.  
 3 Contact Schatz Bearing Corporation's Engineering Department for further technical information.  
 4 Check with Schatz Bearing Corporation's Sales Department for price and availability.

† Refer to p.27 for details.

Materials Options

See page 29  
for details.



52100

## SCHATZ BEARING CORPORATION

A leading producer of high-quality ball bearings and motion control products.

10 Fairview Avenue, Poughkeepsie, New York 12601

Tel: 845.452.6000 • schatzbearing.com • Fax: 845.452.1660

# DSP/MDSP SERIES

Schatz Self-Aligning Type, Double Row Aircraft Control Bearings, Standard Series/Precision Series

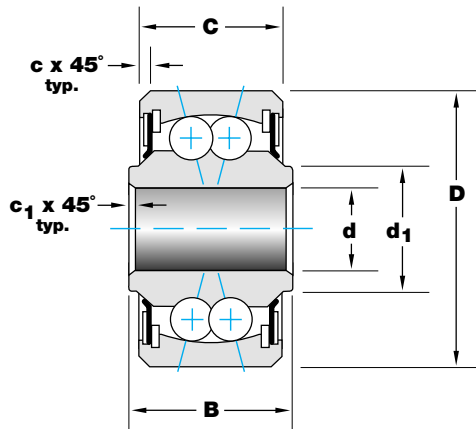

- Manufactured to AS27643 per SAE AS7949
- Double row, ball, self-aligning
- All external surfaces except bore, seals, and stainless steel seal retainers are cadmium plated.
- Installed with Teflon® seals
- Pre-lubricated (see page 8 for grease specifications.)

## MDSP SERIES

- Precision Series **tolerances in gray**

When ordering precision parts be sure to add the "M" prefix to the standard part number.

## DSP/MDSP SERIES BEARING DIMENSIONS AND LOAD RATINGS

Bearing Part Number	MS 27643-	Basic Bearing Dimensions (inches)								Load Ratings (lbs.) †				
		Bore d		O.D. D		Width				d <sub>1</sub>	c <sub>1</sub>	c	Radial Limit	Thrust Limit
		+0.000 -0.005	+0.000 -0.003	+0.000 -0.005	+0.000 -0.004	+0.000 -0.005	+0.000 -0.0025	+0.000 -0.005	+0.000 -0.005					
<b>DSP3</b>	<b>-3</b>	0.1900	0.7774	0.500	0.392	0.304	0.005	0.022	1420	200				
<b>DSP4</b>	<b>-4</b>	0.2500	0.9014	0.687	0.464	0.430	0.005	0.032	1780	300				
<b>DSP5</b>	<b>-5</b>	0.3125	1.2500	0.812	0.656	0.515	0.015	0.032	3740	600				
<b>DSP6</b>	<b>-6*</b>	0.3750	1.4375	0.937	0.750	0.564	0.015	0.032	5100	800				
<b>DSP8</b>	<b>-8*</b>	0.5000	1.6875	1.000	0.812	0.775	0.015	0.044	7120	1000				
<b>DSP10</b>	<b>-10*</b>	0.6250	1.9375	1.125	0.937	0.869	0.015	0.044	9000	1300				

\* Refer to QLP-AS7949 for current approval status.

† Refer to p.27 for details.

- Notes: 1 DSP Series bearings are self-aligning for 10 degrees in either direction.  
 2 Check with Schatz Bearing Corporation for current approval status.  
 3 Contact Schatz Bearing Corporation's Engineering Department for further technical information.  
 4 Check with Schatz Bearing Corporation's Sales Department for price and availability.

Materials Options

See page 29 for details.

52100 ●

440C ●

EMS 138 ●

**SCHATZ BEARING CORPORATION**  
 A leading producer of high-quality ball bearings and motion control products.

10 Fairview Avenue, Poughkeepsie, New York 12601  
 Tel: 845.452.6000 • schatzbearing.com • Fax: 845.452.1660

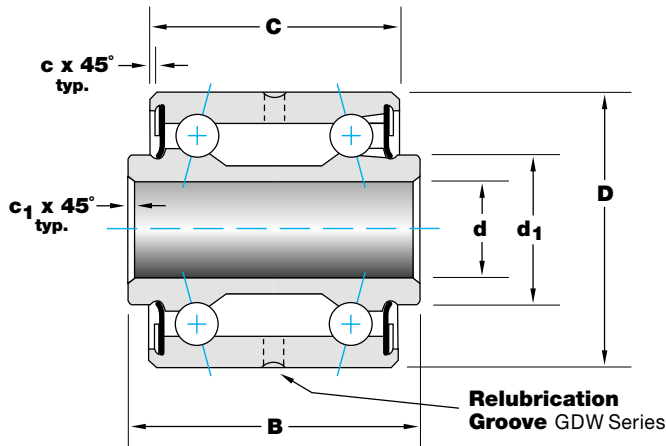

- Manufactured to AS27647 per SAE AS7949
- Extra wide double row, ball
- All external surfaces except bore, seals, and stainless steel seal retainers are cadmium plated.
- Installed with Teflon® seals
- Pre-lubricated (see page 8 for grease specifications.)
- This series is dimensionally interchangeable except the GDW series can be re-lubricated, through holes and a groove in the outer ring.

## MDW, MGDW SERIES

- Precision Series **tolerances in gray**

When ordering precision parts be sure to add the "M" prefix to the standard part number.

## DW, GDW/MDW, MGDW SERIES BEARING DIMENSIONS AND LOAD RATINGS

Bearing Part Number	MS 27647-	Basic Bearing Dimensions (inches)								Load Ratings (lbs.)†				
		Bore d		O.D. D		Width				d <sub>1</sub>	c <sub>1</sub>	c	Radial Limit	Thrust Limit
		+0.000 -0.005	+0.000 -0.003	+0.000 -0.005	+0.000 -0.004	+0.000 -0.005	+0.000 -0.0025	+0.000 -0.005	+0.000 -0.005					
<b>DW4K2*</b>	<b>-4A</b>	0.2500	0.6250	0.562	0.500	0.339	0.005	0.016	1400	500				
<b>GDW4K2*</b>	<b>-4AG</b>	0.2500	0.6250	0.562	0.500	0.339	0.005	0.016	1400	500				
<b>DW4K*</b>	<b>-4</b>	0.2500	0.7500	0.875	0.750	0.380	0.005	0.016	2770	900				
<b>GDW4K*</b>	<b>-4G</b>	0.2500	0.7500	0.875	0.750	0.380	0.005	0.016	2770	900				
<b>DW4</b>	<b>-</b>	0.2500	0.7500	0.875	0.750	0.375	0.005	0.016	3750	1240				
<b>GDW4</b>	<b>-</b>	0.2500	0.7500	0.875	0.750	0.375	0.005	0.016	3750	1240				
<b>DW5</b>	<b>-5</b>	0.3125	0.8750	0.938	0.813	0.469	0.005	0.016	5140	1600				
<b>GDW5</b>	<b>-5G</b>	0.3125	0.8750	0.938	0.813	0.469	0.005	0.016	5140	1600				
<b>DW6</b>	<b>-6</b>	0.3750	1.0625	1.188	1.063	0.573	0.005	0.016	8440	2600				
<b>GDW6</b>	<b>-6G</b>	0.3750	1.0625	1.188	1.063	0.573	0.005	0.016	8440	2600				
<b>DW8</b>	<b>-8</b>	0.5000	1.4375	1.500	1.375	0.712	0.005	0.032	15520	4700				
<b>GDW8</b>	<b>-8G</b>	0.5000	1.4375	1.500	1.375	0.712	0.005	0.032	15520	4700				

\* Retainer type

† Refer to p.27 for details.

- Notes: 1 Do not use bearings as track rollers, cam follower rolls or for similar applications.  
 2 Check with Schatz Bearing Corporation for current approval status.  
 3 Contact Schatz Bearing Corporation's Engineering Department for further technical information.  
 4 Check with Schatz Bearing Corporation's Sales Department for price and availability.

### Materials Options

See page 29  
for details.

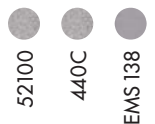

## SCHATZ BEARING CORPORATION

A leading producer of high-quality ball bearings and motion control products.

10 Fairview Avenue, Poughkeepsie, New York 12601

Tel: 845.452.6000 • schatzbearing.com • Fax: 845.452.1660

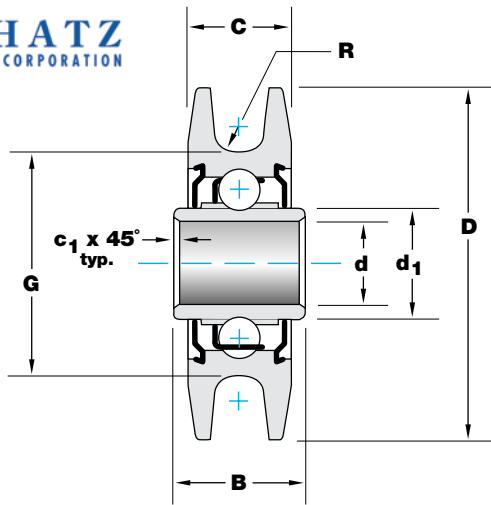

- All external surfaces except bore and stainless steel shields are cadmium plated.
- Installed with stainless shields
- Conrad construction for low torque
- Pre-lubricated (see page 8 for grease specifications.)

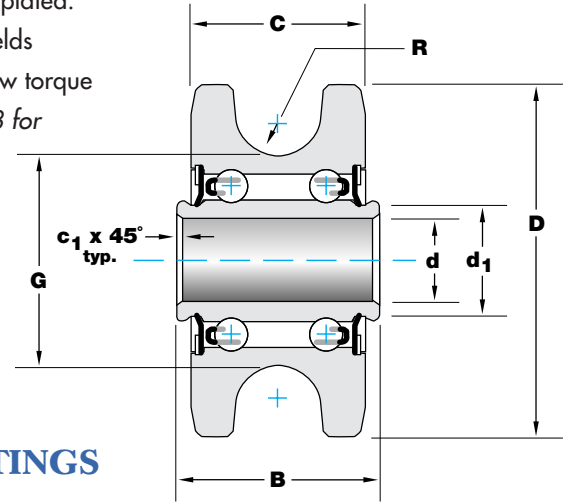

## FL SERIES BEARING DIMENSIONS AND LOAD RATINGS

Basic Bearing Dimensions (inches)

Bearing Part Number	Bore d	O.D. D +0.00 -0.10	Width		d <sub>1</sub> Approx.	c <sub>1</sub> +0.015 -0.000 Chamfer	G	R Radius	Max. Safe Working Radial Load* (lbs.)
			B +0.00 -0.05	C +0.00 -0.05					
<b>FL3C2-3</b> ** ***	0.1905 0.1895	0.500	0.297	0.234	0.237	0.005	0.385	0.055 0.052	80
<b>FL3C3</b>	0.1905 0.1895	0.798	0.297	0.234	0.244	Broken Corner	0.510 0.500	0.055 0.052	200
<b>FL3C3-2</b>	0.1905 0.1895	0.688	0.297	0.234	0.244	Broken Corner	0.510 0.500	0.055 0.052	200
<b>FL3C3-3</b> ***	0.1905 0.1895	0.798	0.297	0.234	0.258	Broken Corner	0.510 0.500	0.055 0.052	200
<b>FL3C6</b>	0.1905 0.1895	1.250	0.484	0.350	0.330	0.010	0.750 0.740	0.112 0.109	500
<b>FL3C6-2</b>	0.1905 0.1895	0.980 0.960	0.484	0.350	0.330	0.010	0.750 0.740	0.112 0.109	500
<b>FL3C6-3</b> *** †	0.1905 0.1895	1.025	0.500	0.410	0.280	0.005	0.755	0.160 0.150	15 (Static Load)
<b>FL3C6-10</b> ***	0.1905 0.1895	1.250	0.484	0.350	0.350	0.010	0.750	0.112 0.109	500
<b>FL3C8-2</b> ©	0.1905 0.1895	0.965	0.406	0.312	0.317	0.005	0.805	0.160 0.150	15 (Static Load)
<b>FL4C6-2</b> ** ***	0.2500 0.2495	1.000	0.5625	0.500	0.339	0.005	0.600 0.590	0.130 0.120	200
<b>FL4C8-3</b> *** †	0.2500 0.2495	1.063	0.348	0.335	0.386	0.005	0.910 0.900	0.160 0.150	200

440C

\* Radial load to obtain 100,000 ft. peripheral travel life

\*\* Double row bearings

\*\*\* Teflon seals

† Inner ring is 440C, outer ring is made of Molybdenum Disulphide Composite.

© Buna N Seal

- Notes: 1 Check with Schatz Bearing Corporation for current approval status.  
 2 Contact Schatz Bearing Corporation's Engineering Dept. for technical information.  
 3 Check with Schatz Bearing Corporation's Sales Dept. for price and availability.

Materials Options

See page 29  
for details.

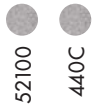

## SCHATZ BEARING CORPORATION

A leading producer of high-quality ball bearings and motion control products.

10 Fairview Avenue, Poughkeepsie, New York 12601

Tel: 845.452.6000 • schatzbearing.com • Fax: 845.452.1660

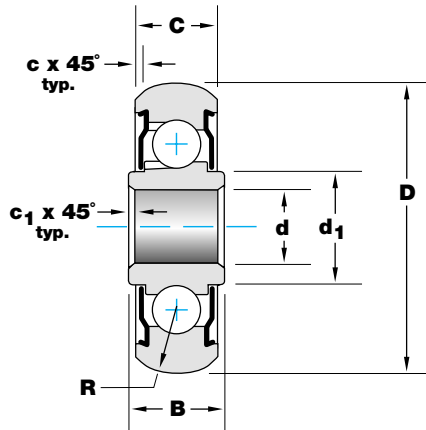

- Single row ball
- All external surfaces except bore and stainless steel seal retainers are cadmium plated.
- Available with removable Teflon® seals or stainless shields
- Pre-lubricated (see page 8 for grease specifications.)

## K SERIES BEARING DIMENSIONS AND LOAD RATINGS

Basic Bearing Dimensions (inches)

Bearing Part Number	Bore d +.0000 -.0005	O.D. D +.0000 -.0020	Width		d <sub>1</sub> Approx.	R Maximum Radius	c <sub>1</sub> +.015 -.000 Chamfer	c Chamfer	Max. Safe Working Radial Load (lbs.) †
			B +.000 -.005	C +.000 -.005					
<b>K3L2</b>	0.1900	0.687	0.245	0.203	0.275	0.187	0.005	0.020	200
<b>K3L3</b>	0.1900	0.635*	0.245	0.203	0.275	0.550	0.005	0.020	200
<b>K3LR48</b>	0.1900	0.687	0.245	0.203	0.275	3.015	0.005	0.020	200
<b>KP3AR11-2</b>	0.1908	0.718**	0.297	0.265	0.297	0.359	0.005	0.015	300
<b>KP4AR13</b>	0.2500	0.800	0.281	0.219	0.375	0.812	0.005	0.015	400
<b>KP4AR48</b>	0.2500	0.800	0.281	0.219	0.375	3.015	0.005	0.015	400
<b>KP4R16</b>	0.2500	0.901	0.484	0.335	0.390	1.000	0.005	0.015	400
<b>KP4R16-2</b>	0.2500	1.000	0.390	0.335	0.390	1.000	0.005	0.015	500
<b>KP4R16-3</b>	0.2500	0.901	0.390	0.335	0.390	1.000	0.005	0.015	400
<b>KP4R21-2</b>	0.2500	1.312	0.376	0.281	0.616	1.312	0.005	0.015	500
<b>KP4R25-2</b>	0.2500	1.656	0.376	0.315	0.616	1.658	0.005	0.015	500
<b>K8AR4</b>	0.5000	1.250	0.344	0.375	0.610	0.252	0.016	0.015	500

\* O.D. tolerances +.000 inch/-.003 inch

\*\* Denotes spherical diameter

† Radial load to obtain 100,000 ft. peripheral travel life.

- Notes: 1 Check with Schatz Bearing Corporation for current approval status.  
 2 Contact Schatz Bearing Corporation's Engineering Department for further technical information.  
 3 Check with Schatz Bearing Corporation's Sales Department for price and availability.

Materials Options

See page 29  
for details.

52100

## SCHATZ BEARING CORPORATION

A leading producer of high-quality ball bearings and motion control products.

10 Fairview Avenue, Poughkeepsie, New York 12601

Tel: 845.452.6000 • schatzbearing.com • Fax: 845.452.1660

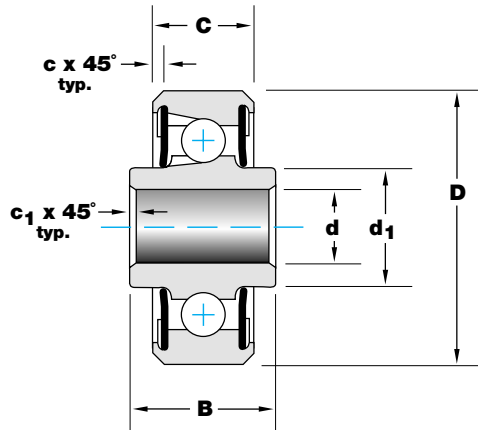

- Manufactured to AS27640 per SAE AS7949
- All external surfaces except bore, seals, and stainless steel seal retainers are cadmium plated.
- Installed with Teflon® seals
- Pre-lubricated (see page 8 for grease specifications.)

### MKP SERIES

- Precision Series **tolerances in gray**

When ordering precision parts be sure to add the "M" prefix to the standard part number.

## KP/MKP SERIES BEARING DIMENSIONS AND LOAD RATINGS

Bearing Part Number	MS 27640-	Basic Bearing Dimensions (inches)								Load Ratings (lbs.) †			
		Bore d		O.D. D		Width B		C	d <sub>1</sub>	c <sub>1</sub>	c	Radial Limit	Thrust Limit
		+0.000 -0.005	+0.000 -0.003	+0.000 -0.005	+0.000 -0.004	+0.000 -0.005	+0.000 -0.0025						
<b>KP3L</b>	<b>-3A</b>	0.1900	0.6250	0.245	0.203	0.280	0.005	0.010	1560	700			
<b>KP3</b>	<b>-3</b>	0.1900	0.7774	0.297	0.270	0.331	0.005	0.022	1880	900			
<b>KP4</b>	<b>-4</b>	0.2500	0.9014	0.484	0.335	0.387	0.005	0.032	2680	1200			
<b>KP5</b>	<b>-5</b>	0.3125	1.2500	0.558	0.375	0.469	0.015	0.032	5620	2500			
<b>KP6</b>	<b>-6</b>	0.3750	1.4375	0.620	0.469	0.591	0.015	0.032	7910	3500			
<b>KP8</b>	<b>-8</b>	0.5000	1.6875	0.620	0.500	0.752	0.015	0.044	11810	5200			
<b>KP10</b>	<b>-10</b>	0.6250	1.9375	0.620	0.500	0.850	0.015	0.044	14100	6200			

† Refer to p.27 for details.

- Notes: 1 Check with Schatz Bearing Corporation for current approval status.  
 2 Contact Schatz Bearing Corporation's Engineering Department for further technical information.  
 3 Check with Schatz Bearing Corporation's Sales Department for price and availability.

#### Materials Options

See page 29 for details.

- 52100
- 440C
- EMS 138

**SCHATZ BEARING CORPORATION**  
 A leading producer of high-quality ball bearings and motion control products.

10 Fairview Avenue, Poughkeepsie, New York 12601  
 Tel: 845.452.6000 • schatzbearing.com • Fax: 845.452.1660



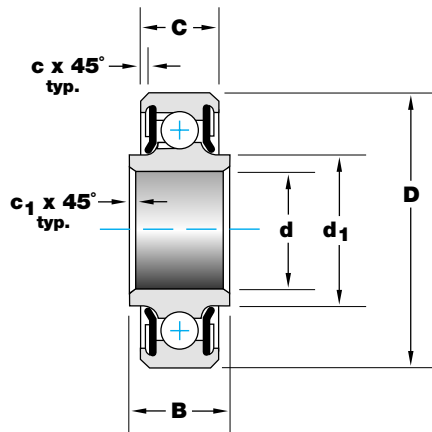

- Manufactured to AS27641 per SAE AS7949
- All external surfaces except bore, seals, and stainless steel seal retainers are cadmium plated.
- Installed with Teflon® seals
- Pre-lubricated (see page 8 for grease specifications.)

### MKP-A SERIES

- Precision Series **tolerances in gray**

When ordering precision parts be sure to add the "M" prefix to the standard part number.

## KP-A/MKP-A SERIES BEARING DIMENSIONS AND LOAD RATINGS

Bearing Part Number	MS 27641-	Basic Bearing Dimensions (inches)							Load Ratings (lbs.) †				
		Bore d		O.D. D		Width			d <sub>1</sub>	c <sub>1</sub>	c	Radial Limit	Thrust Limit
		+0.000 -0.0005	+0.000 -0.0003	+0.000 -0.0005	+0.000 -0.0004	+0.000 -0.005	+0.000 -0.0025	+0.000 -0.005					
<b>KP3A</b>	<b>-3</b>	0.1900	0.6250	0.297	0.234	0.270	0.005	0.016	1560	700			
<b>KP4A</b>	<b>-4</b>	0.2500	0.7500	0.281	0.219	0.349	0.005	0.016	1880	900			
<b>KP5A</b>	<b>-5</b>	0.3125	0.8125	0.297	0.234	0.428	0.015	0.016	2190	1000			
<b>KP6A</b>	<b>-6</b>	0.3750	0.8750	0.313	0.250	0.505	0.015	0.016	2500	1100			
<b>KP8A</b>	<b>-8</b>	0.5000	1.1250	0.375	0.313	0.635	0.015	0.016	3910	1700			
<b>KP10A</b>	<b>-10</b>	0.6250	1.3750	0.406	0.344	0.760	0.015	0.032	6700	3000			
<b>KP12A</b>	<b>-12</b>	0.7500	1.6250	0.437	0.375	0.955	0.015	0.032	8790	3900			
<b>KP16A</b>	<b>-16</b>	1.0000	2.0000	0.500	0.438	1.262	0.015	0.032	11900	5200			
<b>KP20A</b>	<b>-20</b>	1.2500	2.2500	0.500	0.438	1.512	0.015	0.032	13800	6100			

† Refer to p.27 for details.

- Notes: 1 Check with Schatz Bearing Corporation for current approval status.  
 2 Contact Schatz Bearing Corporation's Engineering Department for further technical information.  
 3 Check with Schatz Bearing Corporation's Sales Department for price and availability.

#### Materials Options

See page 29  
for details.

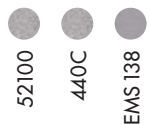

## SCHATZ BEARING CORPORATION

A leading producer of high-quality ball bearings and motion control products.

10 Fairview Avenue, Poughkeepsie, New York 12601

Tel: 845.452.6000 • schatzbearing.com • Fax: 845.452.1660

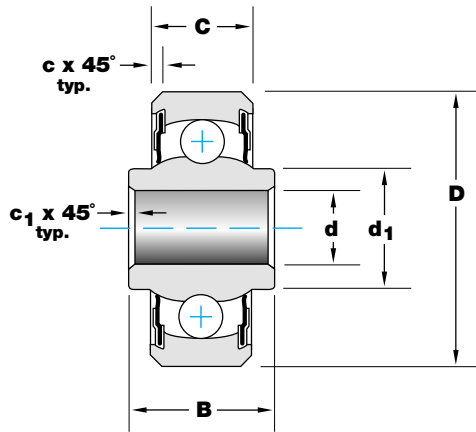

- Single row, ball, self-aligning
- Manufactured to AS27645 per SAE AS7949
- All external surfaces except bore, seals, and stainless steel seal retainers are cadmium plated.
- Installed with Teflon® seals
- Pre-lubricated (see page 8 for grease specifications.)

### MKSP, MKSP-A SERIES

- Precision Series **tolerances in gray**

When ordering precision parts be sure to add the "M" prefix to the standard part number.

## KSP, KSP-A/MKSP, MKSP-A SERIES BEARING DIMENSIONS AND LOAD RATINGS

Bearing Part Number	MS 27645-	Basic Bearing Dimensions (inches)								Load Ratings (lbs.) †				
		Bore d		O.D. D		Width				d <sub>1</sub>	c <sub>1</sub>	c	Radial Limit	Thrust Limit
		+0.000 -0.0010	+0.0000 -0.0003	+0.0000 -0.0010	+0.0000 -0.0004	+0.000 -0.005	+0.0000 -0.0025	+0.000 -0.005	+0.000 -0.005					
<b>KSP3L</b>	<b>-3A</b>	0.1900	0.6250	0.245	0.203	0.256	0.005	0.016	550	100				
<b>KSP4L</b>	<b>-4A</b>	0.2500	0.7500	0.281	0.219*	0.328	0.005	0.016	900	200				
<b>KSP5L</b>	<b>-5A</b>	0.3125	0.8125	0.297	0.234	0.389	0.015	0.016	1000	200				
<b>KSP6L</b>	<b>-6A</b>	0.3750	0.8750	0.313	0.250	0.462	0.016	0.016	1120	200				
<b>KSP3</b>	<b>-3</b>	0.1900	0.7774	0.297	0.270	0.297	0.005	0.022	900	200				
<b>KSP4</b>	<b>-4</b>	0.2500	0.9014	0.484	0.335	0.396	0.005	0.032	1410	300				
<b>KSP5</b>	<b>-5</b>	0.3125	1.2500	0.558	0.375	0.567	0.015	0.032	2190	300				
<b>KSP6</b>	<b>-6</b>	0.3750	1.4375	0.620	0.469	0.612	0.015	0.032	2980	400				
<b>KSP8</b>	<b>-8</b>	0.5000	1.6875	0.620	0.500	0.796	0.015	0.044	3670	500				
<b>KSP10</b>	<b>-10</b>	0.6250	1.9375	0.813	0.625	0.922	0.015	0.044	5320	600				

\* .244 ref. over seal

† Refer to p.27 for details.

- Notes: 1 Bearings are self-aligning for 10 degrees in either direction except for KSP4A, KSP5A, and KSP6A which are self-aligning for 8 degrees in either direction.
- 2 Check with Schatz Bearing Corporation for current approval status.
- 3 Contact Schatz Bearing Corporation's Engineering Department for further technical information.
- 4 Check with Schatz Bearing Corporation's Sales Department for price and availability.

#### Materials Options

See page 29 for details.

- 52100
- 440C
- EMS 138

## SCHATZ BEARING CORPORATION

A leading producer of high-quality ball bearings and motion control products.

10 Fairview Avenue, Poughkeepsie, New York 12601

Tel: 845.452.6000 • schatzbearing.com • Fax: 845.452.1660



# KP-B/MKP-B SERIES

Schatz Torque Tube Type, Aircraft Control Bearings, Standard Series/Precision Series

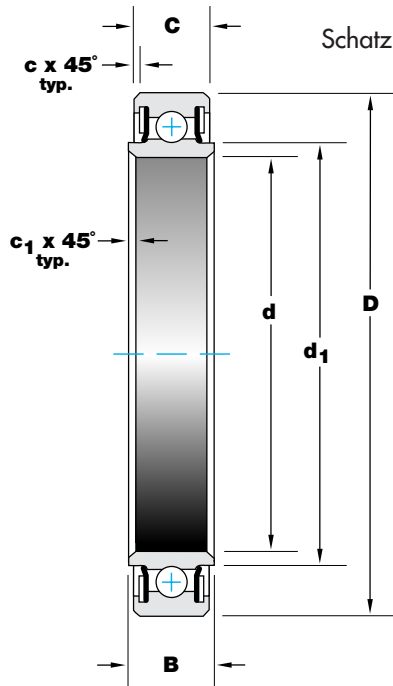

- Single row, ball
- Installed with Teflon® seals
- All external surfaces except bore, seals, and stainless steel seal retainers are cadmium plated.
- Pre-lubricated (see page 8 for grease specifications.)

## MKP-B SERIES

- Precision Series **tolerances in gray**

When ordering precision parts be sure to add the "M" prefix to the standard part number.

## KP-B/MKP-B SERIES BEARING DIMENSIONS AND LOAD RATINGS

Bearing Part Number	Basic Bearing Dimensions (inches)								Load Ratings (lbs.) †				
	Bore d		O.D. D		Width				d <sub>1</sub> Approx.	c <sub>1</sub> +0.015 -0.000	c +0.015 -0.000	Radial Limit	Thrust Limit
	+0.000 -0.0010	+0.0000 -0.0005	+0.0000 -0.0010	+0.0000 -0.0010	B	C	B	C					
<b>KP16B</b>	1.0000*		1.7500		0.437	0.375	1.141	0.024	0.024	8090	3600		
<b>KP21B</b>	1.3130		2.0625		0.437	0.375	1.454	0.024	0.024	9640	4400		
<b>KP23B</b>	1.4380		2.1875		0.437	0.375	1.574	0.024	0.024	10500	4700		
<b>KP25B</b>	1.5630		2.3125		0.437	0.375	1.693	0.024	0.024	11300	5000		
<b>KP29B</b>	1.8130		2.5625		0.437	0.375	1.931	0.024	0.024	12700	5600		
<b>KP33B</b>	2.0630		2.8125		0.437	0.375	2.231	0.024	0.024	14400	6400		
<b>KP37B</b>	2.3130		3.0625		0.437	0.375	2.468	0.024	0.024	15800	7000		
<b>KP47B</b>	2.9380		3.8750		0.531	0.469	3.093	0.039	0.039	24700	10900		
<b>KP49B</b>	3.0630		4.0000		0.531	0.469	3.222	0.039	0.039	27500	12100		
<b>KP52B</b>	3.2500		4.1875		0.531	0.469	3.479	0.039	0.039	28700	12600		
<b>KP56B</b>	3.5000		4.4375		0.531	0.469	3.775	0.039	0.039	31200	13700		

\* +0.0000 inch/-0.0005 inch

† Refer to p.27 for details.

- Notes: 1 Do not use bearings as track rollers, cam follower rolls or for similar applications.  
 2 Check with Schatz Bearing Corporation for current approval status.  
 3 Contact Schatz Bearing Corporation's Engineering Department for further technical information.  
 4 Check with Schatz Bearing Corporation's Sales Department for price and availability.

### Materials Options

See page 29 for details.

- 52100
- 440C
- EMS 138

## SCHATZ BEARING CORPORATION

A leading producer of high-quality ball bearings and motion control products.

10 Fairview Avenue, Poughkeepsie, New York 12601

Tel: 845.452.6000 • schatzbearing.com • Fax: 845.452.1660

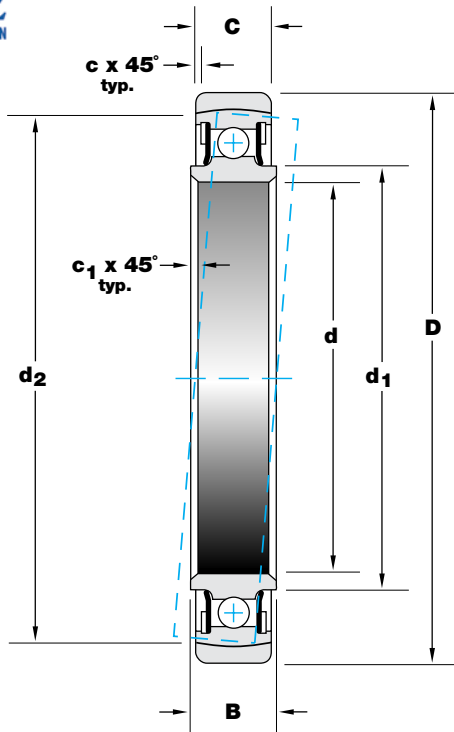

- Manufactured to AS27648 per SAE AS7949
- Single row, ball, external self-aligning
- Installed with Teflon® seals
- All external surfaces except bore and stainless steel seal retainers are cadmium plated.
- Pre-lubricated (see page 8 for grease specifications.)
- Designed to compensate for initial misalignment, the KP-BS series is internally identical to the KP-B series on the previous page. Self-alignment is performed by an external self-aligning ring whose internal spherically-ground surface is accurately matched to the external spherically-ground surface of the outer ring.

### MKP-BS SERIES

- Precision Series **tolerances in gray**

When ordering precision parts be sure to add the "M" prefix to the standard part number.

## KP-BS/MKP-BS SERIES BEARING DIMENSIONS AND LOAD RATINGS

Bearing Part Number	MS 27648-	Basic Bearing Dimensions (inches)								Load Rating †				
		Bore d		O.D. D		Width B		C	d <sub>1</sub>	c <sub>1</sub>	c	d <sub>2</sub> to sharp corner	Mis-alignment angle (1)	Radial Limit (lbs.)
		+0.000 -0.010	+0.000 -0.005	+0.000 -0.010	+0.000 -0.010	+0.00 -0.05	+0.000 -0.025	+0.00 -0.05	+0.00 -0.05	Approx.	+0.015 -0.00	+0.015 -0.00		
<b>KP16BS</b>	<b>-16*</b>	1.0000**		1.9375		0.437	0.375		1.141	0.024	0.024	1.709	7° 25'	8090
<b>KP21BS</b>	<b>-21*</b>	1.3130		2.2500		0.437	0.375		1.454	0.024	0.024	2.028	6° 30'	9840
<b>KP23BS</b>	<b>-23*</b>	1.4380		2.3750		0.437	0.375		1.575	0.024	0.024	2.155	6°	10500
<b>KP25BS</b>	<b>-25*</b>	1.5630		2.5000		0.437	0.375		1.693	0.024	0.024	2.282	5° 45'	11300
<b>KP29BS</b>	<b>-29</b>	1.8130		2.7500		0.437	0.375		1.931	0.024	0.024	2.535	5°	12700
<b>KP33BS</b>	<b>-33</b>	2.0630		3.0000		0.437	0.375		2.231	0.024	0.024	2.787	5°	14400
<b>KP37BS</b>	<b>-37</b>	2.3130		3.2500		0.437	0.375		2.468	0.024	0.024	3.039	4° 30'	15800
<b>KP47BS</b>	<b>-47*</b>	2.9380		4.1250		0.531	0.469		3.093	0.039	0.039	3.846	4° 30'	24700
<b>KP48BS</b>	<b>-48*</b>	3.0000		4.2500		0.531	0.469		3.222	0.039	0.039	3.972	4°	27500
<b>KP49BS</b>	<b>-49*</b>	3.0625		4.2500		0.531	0.469		3.222	0.039	0.039	3.972	4°	27500

\* Refer to QLP-AS7949 for current approval status.

\*\* +0.000 inch/-0.005 inch

† Refer to p.27 for details.

Notes: 1 KP-BS Series bearings are self-aligning in either direction.

2 Check with Schatz Bearing Corporation for current approval status.

3 Contact Schatz Bearing Corporation's Engineering Department for further technical information.

4 Check with Schatz Bearing Corporation's Sales Department for price and availability.

#### Materials Options

See page 29 for details.

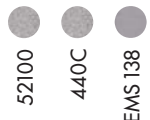

## SCHATZ BEARING CORPORATION

A leading producer of high-quality ball bearings and motion control products.

10 Fairview Avenue, Poughkeepsie, New York 12601

Tel: 845.452.6000 • schatzbearing.com • Fax: 845.452.1660

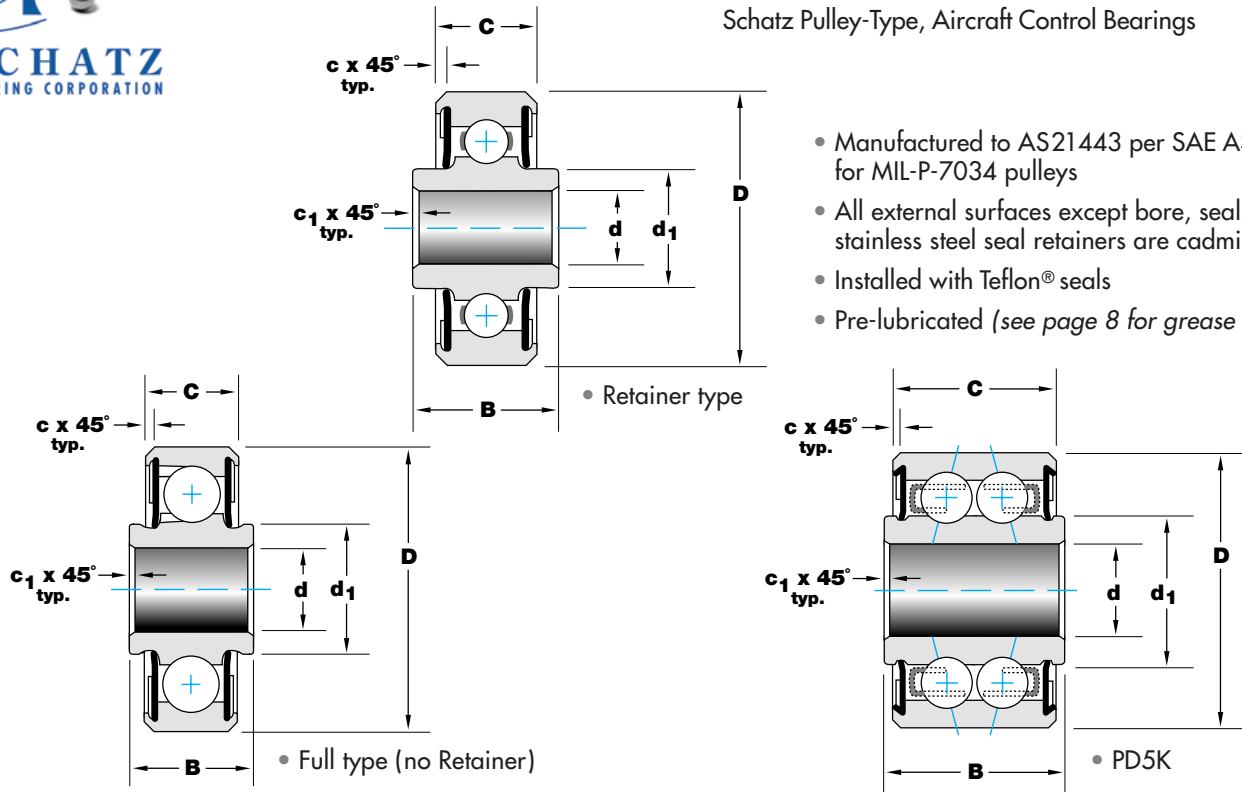

- Manufactured to AS21443 per SAE AS7949 for MIL-P-7034 pulleys
- All external surfaces except bore, seals, and stainless steel seal retainers are cadmium plated.
- Installed with Teflon® seals
- Pre-lubricated (see page 8 for grease specifications.)

## P SERIES BEARING DIMENSIONS AND LOAD RATINGS

Bearing Part Number	MS 21443-	Basic Bearing Dimensions (inches)							Load Ratings (lbs.) †	
		Bore d +.0000 -.0005	O.D. D +.0000 -.0005	Width B C +.000 -.005		d <sub>1</sub> Approx.	c <sub>1</sub> +.015 -.000	c +.015 -.000	Radial Limit	Thrust Limit
<b>KP3K</b>	<b>-3B</b>	0.1900	0.7774	0.297	0.270	0.332	0.005	0.024	1090	600
<b>KP3AK</b>	<b>-3A</b>	0.1900	0.6250	0.297	0.234	0.297	0.005	0.016	705	385
<b>KP3AK-2</b>		0.1900	0.6250	0.625	0.234	0.297	0.005	0.016	705	385
<b>W4AK</b>	<b>-4A</b>	0.2500	0.7500	0.438	0.312	0.372	0.005	0.016	1090	600
<b>KP4K</b>	<b>-4C</b>	0.2500	0.9014	0.484	0.335	0.390	0.005	0.034	1710	800
<b>P4K</b>	<b>-4B</b>	0.2500	0.8750	0.438	0.375	0.423	0.005	0.022	1710	800
<b>P5K</b>	<b>-5A</b>	0.3125	0.8750	0.625	0.375	0.455	0.005	0.022	1710	800
<b>PD5K</b>	<b>-5B</b>	0.3125	0.9375	0.625	0.563	0.455	0.005	0.022	3420	1030
<b>P8*</b>	<b>-8</b>	0.5000	1.6875	0.750	0.563	0.768	0.005	0.032	11800	5200
<b>P10K</b>	<b>-10</b>	0.6250	1.1875	0.438	0.375	0.769	0.005	0.022	2440	1100

\* Full type—no retainer.

† Refer to p.27 for details.

- Notes: 1 Designed for use in pulleys, the P Series bearings work well in other airframe applications. Do not use bearings as track rollers, cam follower rolls or for similar applications.
- 2 Check with Schatz Bearing Corporation for current approval status.
- 3 Contact Schatz Bearing Corporation's Engineering Department for further technical information.
- 4 Check with Schatz Bearing Corporation's Sales Department for price and availability.

Materials Options

See page 29 for details.

- 52100
- 440C
- EMS 138

**SCHATZ BEARING CORPORATION**  
A leading producer of high-quality ball bearings and motion control products.

10 Fairview Avenue, Poughkeepsie, New York 12601  
Tel: 845.452.6000 • schatzbearing.com • Fax: 845.452.1660



# ENGINEERING INDEX

Schatz Bearing Capabilities, Options, and Technical Data

## BEARING ENGINEERING

Schatz Bearings Types .....	p.25
Aircraft Control Bearings Specifications .....	p.26
Load Ratings and Life Calculations and Life Adjustment Factors .....	p.27
Lubrication Choices Table .....	p.28

## SCHATZ MATERIALS AND DESIGN OPTIONS

Materials Options .....	p. 29
Retainer Cage Materials and Options .....	p. 30
Closure Options: Seals and Shields .....	p.31

## ABEC TOLERANCES TABLES

ABEC 1 Tolerances for Inner Ring, Outer Ring, and Width .....	p.32
ABEC 3 Tolerances for Inner Ring, Outer Ring, and Width .....	p.33
ABEC 5 Tolerances for Inner Ring, Outer Ring, and Width .....	p.34
ABEC 7 Tolerances for Inner Ring, Outer Ring, and Width .....	p.35

## SPECIAL CAPABILITIES

Bearings for Special Applications .....	p. 36
---	-------

## SCHATZ BEARING CORPORATION

*A leading producer of high-quality ball bearings and motion control products.*

10 Fairview Avenue, Poughkeepsie, New York 12601

Tel: 845.452.6000 • [schatzbearing.com](http://schatzbearing.com) • Fax: 845.452.1660



## BEARING TYPES

### Radial Bearings

These are non filling slot bearings that are suitable for applications that have radial or thrust loads or combination loading.

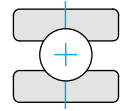

### Angular Contact Bearings

These bearings are designed to give maximum capacity for thrust loads in one direction, or combined radial and thrust loads where the thrust load is primary. These bearings should not be used for pure radial loads. Many of the Radial Series bearings listed in this catalog can be manufactured as Angular Contact Bearings (please contact Schatz Customer Service or Engineering for further information). For applications with thrust loads in either direction, these bearings can be mounted in pairs. See description for Duplex Bearings.

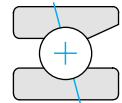

### Duplex Bearings

Duplex bearings are two single row bearings that are manufactured to be mounted in pairs. Duplex bearings offer greater stiffness and are typically preloaded. Preloading is the process of grinding a predetermined amount of material off of the faces of each bearing to achieve a mounted internal deflection. This pre-set internal deflection decreases the amount of application deflection experienced by external loading, therefore increasing the stiffness of the bearing set. Duplex bearings can be mounted in the following configurations:

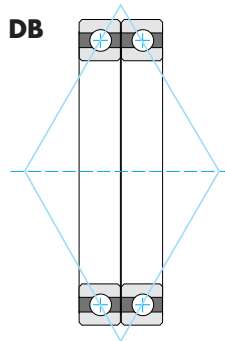

### Back-to-Back (DB)

These bearings are mounted with the contact angles divergent to the shaft. The preload on these bearings is achieved by clamping the inner rings together after mounting. This mounting arrangement is preferred when high moment rigidity is needed.

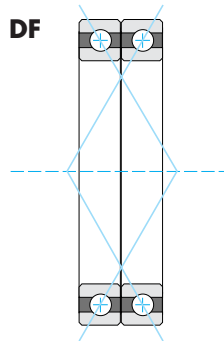

### Face-to-Face (DF)

These bearings are mounted with the contact angles convergent to the shaft. The preload is achieved by clamping the outer rings together. This arrangement is best suited for slow speed applications where misalignment occurs or where the assembly necessitates it.

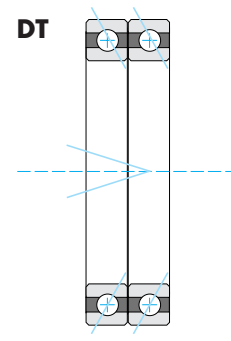

### Tandem (DT)

These bearings are mounted with parallel contact angles. The tandem arrangement is used to increase capacity to support a unidirectional thrust load.

### Double Row Angular Contact Bearings

These bearings utilize two rows of balls and offer increased capacity and rigidity in a compact space. These bearings have high radial capacity and have thrust capacity in both directions. Schatz manufactures many different double row series and cross sections and many of them are not detailed in this catalog. Please consult Schatz Customer Service or Engineering for more information on the availability of double row product.

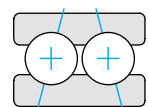

## SCHATZ BEARING CORPORATION

*A leading producer of high-quality ball bearings and motion control products.*

10 Fairview Avenue, Poughkeepsie, New York 12602

Tel: 845.452.6000 • [schatzbearing.com](http://schatzbearing.com) • Fax: 845.452.1660

## Maximum Capacity

These bearings are provided with filling slots to allow for an increased number of balls. The increased number of balls allows for increased radial capacity. However, due to the filling slots, the thrust capacity of these bearings is limited. These bearings should be used in applications that have primarily heavy radial load with light thrust components. These bearings should not be used in applications that have pure thrust loading or are primarily thrust loaded.

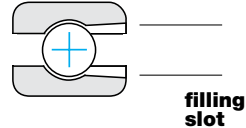

## Internal Clearances

Ball bearings are assembled with a specified amount of looseness between the inner and outer ring raceways and balls. This looseness or internal clearance is designed to compensate for mounting fits, thermal expansion, or application factors. This clearance can be measured in the radial and axial direction. Radial internal clearance is the amount of total movement in the radial direction of one ring, measured while the other ring is held in place. This is calculated by the following: the average outer ring raceway diameter minus the average inner ring raceway diameter minus twice the ball diameter. Axial internal clearance is the total amount of axial movement of one ring, measured while the other ring is held in place. The specifications for radial internal clearance for the Schatz Precision Series are listed in the table on this page. The specifications for the Aircraft Control bearing product are listed in the table on page 27. Please consult the Schatz engineering department for assistance with the specific needs of your application.

**Internal Clearance Acceptance Limits for Precision Series Bearings\***

Basic Bore Diameter mm		1 Standard		2 Tight		3 Loose		4 Extra Loose	
Over	Incl.	low	high	low	high	low	high	low	high
2.5	10	1	5	0	3	3	9	6	11
		2	13	0	7	8	23	14	29
10	18	1	7	0	3.5	4	10	7	13
		3	18	0	9	11	25	18	33
18	24	2	8	0	4	5	11	8	14
		5	20	0	10	13	28	20	36
24	30	2	8	0.5	4.5	5	11	9	16
		5	20	1	11	13	28	23	41
30	40	2	8	0.5	4.5	6	13	11	18
		6	20	1	11	15	33	28	46
40	50	2.5	9	0.5	4.5	7	14	12	20
		6	23	1	11	18	36	30	51
50	65	3.5	11	0.5	6	9	17	15	24
		8	28	1	15	23	43	38	61
65	80	4	12	0.5	6	10	20	18	28
		10	30	1	15	25	51	46	71
80	100	4.5	14	0.5	7	12	23	21	33
		12	36	1	18	30	58	53	84
100	120	6	16	1	8	14	26	24	38
		15	41	2	20	36	66	61	97
120	140	7	19	1	9	16	32	28	45
		18	48	2	23	41	81	71	114
140	160	7	21	1	9	18	36	32	51
		18	53	2	23	46	91	81	130
160	180	8	24	1	10	21	40	36	58
		20	61	2	25	53	102	91	147
180	200	10	28	1	12	25	46	42	64
		25	71	2	30	63	117	107	163
200	240	12	32	1	14	29	54	50	76
		30	81	3	36	74	137	127	193

\* Dimensions in ten-thousandths inches (.0001")

Dimensions in micrometers

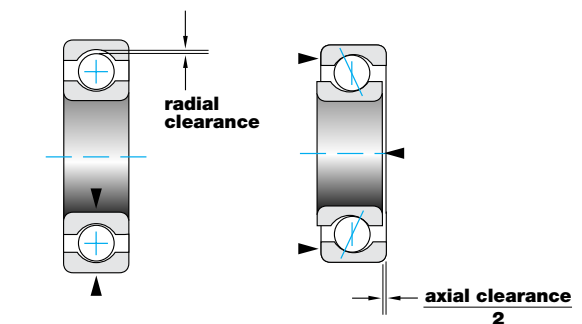

## SCHATZ BEARING CORPORATION

A leading producer of high-quality ball bearings and motion control products.

10 Fairview Avenue, Poughkeepsie, New York 12601

Tel: 845.452.6000 • schatzbearing.com • Fax: 845.452.1660

## Specifications for Aircraft Control Bearings

<b>Radial Internal Clearance</b>	Standard Series	KP, KP-A and DPP	4	10
	Precision Series	MKP, MKP-A, MKSP, MKSP-A, MDPP, MDSP and MDW	2	5
	Standard Series	KSP, KSP-A, DSP and DW	0	10
	Standard Series	KP-B and KP-BS	3	10
	Precision Series	MKP-B and MKP-BS	1	5
	Standard Series	B500 and B500DD	8	18
	Precision Series	MB500 and MB500DD	1	5

Dimensions in ten-thousandths inches (.0001")

### Shaft and Housing Fits

It is essential for proper operation that small, heavily loaded bearings in oscillating service be mounted in housings with a light but positive interface (press) fit. Staking or spinning of the housing over the outer ring chamfer is recommended to secure the bearing axially. In some applications involving considerable thrust load a housing shoulder is desirable.

## LOAD RATINGS AND LIFE CALCULATIONS

### Aircraft Control Bearings Load Limit Rating

The Limit Load Ratings listed in this catalog were developed to rate bearings that operate in slow speed applications such as those encountered in aircraft control applications. For *Bearing Life Calculations*, please consult the Schatz Engineering Department.

### Basic Dynamic Radial Load Rating $C_r$

Schatz dynamic radial load ratings are the radial bearing loads that will give a basic rating life of 1,000,000 revolutions. The basic dynamic load ratings have been determined in accordance with the methods prescribed by ISO, ABMA, and ANSI.

### Bearing Fatigue Life

If a population of identical bearings is subjected to identical operating conditions, there will be a significant dispersion of fatigue life between individual bearings. Therefore, fatigue life is often expressed in the number of hours that 90% of a group of identical bearings will exceed under a given set of conditions or  $L_{10}$  life.

Where:

The basic equation for radial ball bearings is:

$$L_{10} = \frac{16,667 * A1 * A2 * A3}{S(C_r/P)^3}$$

$C_r$  – basic Dynamic Radial Load Rating (listed in catalog)

$P$  – applied

$S$  – speed in RPM

$A1$  – life adjustment factor for reliability

$A2$  – life adjustment factor for material

$A3$  – life adjustment factor for lubrication

## LIFE ADJUSTMENT FACTORS

Many life adjustment factors can be applied to the calculated bearing life as stated above. These factors are simply multiplied by the bearing life to determine the final expected operating life of the bearing.

$$L_{10} \text{ (calculated)} * A1 * A2 * A3 = \text{Adjusted Bearing Life}$$

The three life adjustment factors that Schatz recommends using are:

$A1$  – life adjustment factor for reliability

$A2$  – life adjustment factor for material

$A3$  – life adjustment factor for lubrication

## SCHATZ BEARING CORPORATION

*A leading producer of high-quality ball bearings and motion control products.*

10 Fairview Avenue, Poughkeepsie, New York 12601

Tel: 845.452.6000 • schatzbearing.com • Fax: 845.452.1660

### Reliability (A1):

All formulas are based on an **L<sub>10</sub>** life. If a different life needs to be calculated, use the following table for the adjustment factor:

Reliability (%)	90 ( <b>L<sub>10</sub></b> )	95 ( <b>L<sub>5</sub></b> )	96 ( <b>L<sub>4</sub></b> )	97 ( <b>L<sub>3</sub></b> )	98 ( <b>L<sub>2</sub></b> )	99 ( <b>L<sub>1</sub></b> )
Factor ( <b>A1</b> )	1.00	.62	.53	.44	.33	.21

### Material (A2):

There are several material options for use with Schatz bearings. The following chart shows the life adjustment factors for the materials offered:

Material Type	52100	440C	Schatz EMS 138
Factor ( <b>A2</b> )	2.2	.6	4.2

### Lubrication (A3):

Lubrication and the presence of an elastic-hydrodynamic lubrication film is critical to achieving proper bearing life. Please consult the Schatz engineering department for information on determining the lubrication factor for a specific application. While the calculation for the specific lubrication film thickness is complex, in general, choosing a grease with a base oil that has a high viscosity is more suitable for low to moderate speed and high load applications. Alternatively, grease with a low viscosity base oil is more suitable for high speed applications with light to moderate loads.

Name	Manufacturer	Mil-SPEC	Lube Type	Temperature Range (°F)	Oil Type	Thickener Type	Color	Viscosity @ 100°F	Viscosity @ 210°F	Characteristics/ Application
<b>Aeroshell 22</b>	Shell Oil Co.	MIL-PRF-81322	Grease	-80 to 350	SH	Microgel	Dark Grey	30.5 cSt	5.7 cSt	General purpose
<b>Aeroshell 33</b>	Shell Oil Co.	MIL-PRF-23827	Grease	-99 to 250	SH/Ester	Lithium	Green	14.2 cSt	3.4 cSt	Aircraft, Gen. purpose, Corrosion-inhibiting
<b>Aeroshell 7</b>	Shell Oil Co.	MIL-PRF-23827	Grease	-100 to 300	Synthetic	Microgel	Amber	10.3 cSt	3.1 cSt	Wide temperature range
<b>Alvania #2</b>	Shell Oil Co.	—	Grease	-65 to 275	Mineral	Lithium	Amber	189 cSt	15.6 cSt	General purpose
<b>Asonic HQ 72-102</b>	Kluber	—	Grease	-40 to 356	Ester	Polyurea	Beige	100 cSt	12 cSt	High temperature
<b>Beacon 325</b>	Exxon Corp.	MIL-PRF-23827	Grease	-65 to 250	Diester	Lithium	Light Tan	12 cSt	—	General purpose
<b>Braycote 815</b>	Castrol	—	Oil	-100 to 400	PFPE	—	—	148 cSt	45 cSt	Wide temperature range, Chemically inert
<b>Braycote 601 EF</b>	Castrol	—	Grease	-112 to 400	PFPE	—	Off-White	148 cSt	45 cSt	High-vacuum grease
<b>Braycote Micronic 1613</b>	Castrol	—	Grease	-99 to 400	PFPE	—	Off-White	148 cSt	45 cSt	High-vacuum grease, Long shelf life
<b>Isoflex NBU 15</b>	Kluber	—	Grease	-40 to 265	SH/Est./Min.	Alkaline Earth	Beige	21 cSt	4.7 cSt	High speed
<b>Krytox 240 AC</b>	Dupont	—	Grease	-30 to 550	Fluorinated	Fluorotelomer	White	270 cSt	—	Stable at high temperatures
<b>Mobil 28</b>	Mobil Oil	MIL-PRF-81322	Grease	-65 to 350	SH	Clay	Dark Red	29.3 cSt	—	Wide temperature range
<b>Mobil SHC 220</b>	Mobil Oil	—	Grease	-40 to 350	SH	Lithium	Red	220 cSt	23.8 cSt	High wear resistance, Corrosion resistance
<b>RheoTemp 500</b>	NYE	—	Grease	-65 to 350	Diester	Sodium	Dark Blue	51 cSt	8.9 cSt	High speed, Moderate temperature
<b>RheoLube 2000</b>	NYE	—	Grease	-49 to 257	SH	Organic Gel	Light Tan	110 cSt	15 cSt	Low temp. operation, Vacuum Applications
<b>RheoLube 374-C*</b>	NYE	—	Grease	-40 to 248	SH	Lithium	Tan	60.7 cSt	9.5 cSt	Superior washout characteristics
<b>RheoTemp 700B</b>	NYE	—	Grease	-40 to 347	Polyester	Lithium	Blue Black	51 cSt	8.9 cSt	High speed, High temperature
<b>SRI-2</b>	Chevron Oil Co.	—	Grease	-20 to 350	Mineral	Polyurea	Blue/Green	100 cSt	11 cSt	General purpose

\* Replacement for Andok C      SH- Synthetic Hydrocarbon



**SCHATZ BEARING CORPORATION**  
A leading producer of high-quality ball bearings and motion control products.

10 Fairview Avenue, Poughkeepsie, New York 12601  
Tel: 845.452.6000 • schatzbearing.com • Fax: 845.452.1660

## RINGS AND BALLS

### SAE 52100

This is the most commonly used high-quality bearing material and contains 1% carbon and 2.5% chromium. It offers good wear resistance. The standard stabilization temperature range for Schatz aircraft bearings utilizing SAE 52100 is -65°C to 250°F. Special heat treatment can increase the maximum operating temperature to 400°F.

### 440C

The most commonly used stainless steel bearing material. It is fully hardened (Rc 58-61) and offers moderate wear resistance and can be used in moderately corrosive environments. The standard maximum operating temperature for Schatz aircraft bearings utilizing 440C is 300°F. Special heat treatment can increase the maximum operating temperature to 450°F.

### 440C Modified

This material offers corrosion resistance for applications requiring high operating temperatures. Maximum operating temperature is 850°F.

### EMS 138 Stainless Steel (X.D15N.W)

This is a stainless bearing steel that offers very good corrosion resistance and excellent wear resistance. Standard heat treatment for Schatz aircraft bearings utilizing this material allow for operating temperatures up to 300°F. A special heat treatment can be applied to allow for operating temperatures up to 850°F.

### M50

This is an aerospace bearing material that offers excellent fatigue and wear resistance at moderate to high operating temperatures. The maximum operating temperature for bearings utilizing this material is 600°F.

### Hybrid Bearings with Steel Rings and Ceramic Balls

Bearings utilizing steel inner and outer rings with ceramic rolling elements offer higher speed capability, higher stiffness, and extended wear life.

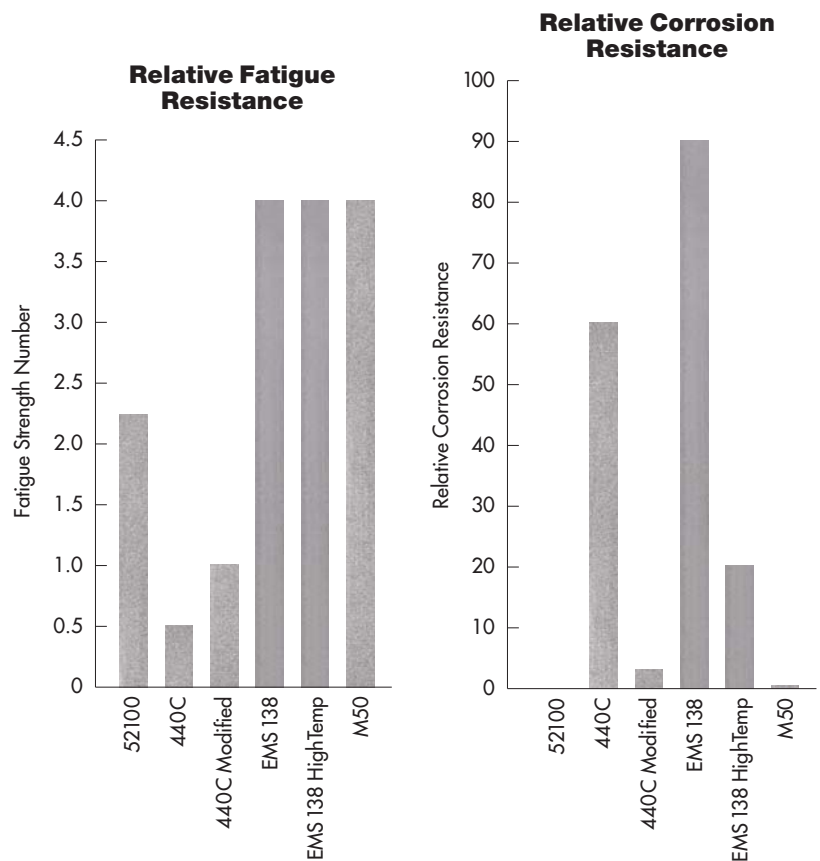

## SCHATZ BEARING CORPORATION

*A leading producer of high-quality ball bearings and motion control products.*

10 Fairview Avenue, Poughkeepsie, New York 12601

Tel: 845.452.6000 • [schatzbearing.com](http://schatzbearing.com) • Fax: 845.452.1660

## RETAINER OPTIONS

### Pressed Steel, Tabbed Style (Steel or Stainless Steel)

These cages are made from pressed low carbon steel or 300 Series stainless steel.



### Riveted or Bent-Tab, Ball Piloted, Ribbon Style (Carbon Steel or Stainless Steel)

These cages are made from pressed low carbon steel or 300 Series stainless steel. This is the standard cage used in the 1900, 9100, 1200, 1300, and "R" Series precision bearings.



### Machined, Ring-Piloted (Carbon Steel, Stainless Steel, Bronze, Al-Bronze, Phenolic)

These ring-piloted cages are designed for high durability and accuracy and can be used for high-load and high-speed applications.



### Machined, Full Pocket, Ball-Piloted, or Ring-Piloted (Carbon Steel, Stainless Steel, Bronze, Al-Bronze, Phenolic)

The full ball pocket cages are offered on angular contact bearings. Please consult the Schatz engineering department for further details.



### Special Cages

Schatz offers many special cages with features to suit specific application or design needs. Examples are thin cross-section cages for aircraft bearings, cages specially designed to withstand high acceleration, or cages made with high-temperature materials. Additionally, Schatz can manufacture cages with several coatings to suit application needs.

Please consult the Schatz engineering department for further information.

## SCHATZ BEARING CORPORATION

*A leading producer of high-quality ball bearings and motion control products.*

10 Fairview Avenue, Poughkeepsie, New York 12601

Tel: 845.452.6000 • [schatzbearing.com](http://schatzbearing.com) • Fax: 845.452.1660



## BEARING SHIELDS

Shields are the basic ball bearing closures. They protect the bearing from large particle contamination and also help retain lubricant. The shield does not contact the inner ring and protection is afforded by the close running tolerances between the i.d. of the shield and the inner ring step.

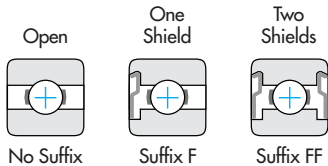

Shields are available in carbon and stainless steel. Additionally, some bearings can be manufactured with removable shields to facilitate periodic relubrication. (Check with Schatz's engineering department for the availability of removable shields.)



## BEARING SEALS

Seals are a positive contacting closure that protects the bearing contamination and provide an excellent retention of grease. There are numerous materials and designs available for seal options. The following is a list of the standard Schatz sealing designs:

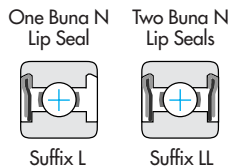

### Buna N molded rubber lip seal

The rubber lip seal provides excellent protection due to the face contacting seal. The seal is available as a molded seal with a steel insert, or as steel shrouded with Buna N inserts. The operating temperature range of these seals is 65°F to 225°F.



### Teflon® Lip seals

These seals provide a wider operating temperature range than the rubber seal (maximum operating temperature of 550°F). Additionally, the Teflon® contact results in lower starting torque, therefore these seals can be used in applications where torque sensitivity is a consideration. Most designs incorporate a steel retaining ring to support the Teflon® disk. Some designs are removable.

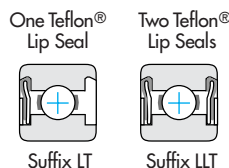

These seals provide a wider operating temperature range than the rubber seal (maximum operating temperature of 550°F). Additionally, the Teflon® contact results in lower starting torque, therefore these seals can be used in applications where torque sensitivity is a consideration. Most designs incorporate a steel retaining ring to support the Teflon® disk. Some designs are removable.



### Special seals

Schatz has designed many special seals to accommodate the needs of difficult applications. Seals are available that are designed for use in high temperatures, high operating speeds, low starting torque, or that are designed to operate in environments of extreme contamination. Please consult the Schatz engineering department for further information on seal designs.



## INNER RING

Specifications for Metric and Inch Ball Bearings (all tolerances shown are in .0001 inch)

Bore Diameter d				Bore Tolerance Limits				Raceway Radial Runout
mm		Inches		d <sub>m</sub>		d <sub>min</sub> d <sub>max</sub>		
Over	Incl.	Over	Incl.	Low	High			
0	10	0	0.3937	-3	+0	-4	+1	4
10	18	0.3937	0.7087	-3	+0	-4	+1	4
18	30	0.7087	1.1811	-4	+0	-5	+1	5
30	50	1.1811	1.9685	-4	+0	-7	+2	6
50	80	1.9685	3.1496	-6	+0	-8	+2	8
80	120	3.1496	4.7244	-8	+0	-11	+3	10
120	150	4.7244	7.0866	-10	+0	-13	+3	12
150	180	4.7244	7.0866	-10	+0	-13	+3	12
180	250	7.0866	9.8425	-12	+0	-16	+4	16

## OUTER RING

Specifications for Metric and Inch Ball Bearings (all tolerances shown are in .0001 inch)

Bore Diameter d				Outside Diameter Tolerance Limits						Raceway Radial Runout
mm		Inches		D <sub>m</sub>		Open Bearings		Shielded/Sealed Bearings		
Over	Incl.	Over	Incl.	High	Low	D <sub>max</sub>	D <sub>min</sub>	D <sub>max</sub>	D <sub>min</sub>	
0	18	0	0.7078	+0	-3	+1	-5	+2	-6	6
18	30	0.7078	1.1811	+0	-3	+1	-5	+2	-6	6
30	50	1.1811	1.9685	+0	-4	+2	-7	+4	-9	8
50	80	1.9685	3.1496	+0	-5	+2	-7	+4	-9	10
80	120	3.1496	4.7244	+0	-6	+3	-9	+6	-12	14
120	150	4.7244	5.9055	+0	-7	+3	-11	+6	-14	16
150	180	5.9055	7.0866	+0	-10	+3	-13	+6	-16	18
180	250	7.0866	9.8425	+0	-12	+4	-16	+8	-20	20
250	315	9.8425	12.4015	+0	-14	+4	-18	+8	-22	24

## WIDTH TOLERANCES

Specifications for Metric and Inch Ball Bearings (all tolerances shown are in .0001 inch)

Bearings Other Than Duplex Width of Individual Inner or Outer Ring

Duplex Bearings Total Width of Inner or Outer Ring\*

Inner Ring Bore				Width Tolerance Limits		Inner Ring Bore				Width Tolerance Limits	
mm		Inches				mm		Inches			
Over	Incl.	Over	Incl.			Over	Incl.	Over	Incl.		
0	10	0	7.0866	+0	-50	0	80	0	3.1496	+0	-200
180	315	7.0866	12.4015	+0	-100	80	180	3.1496	7.0866	+0	-300
—	—	—	—	—	—	180	315	7.0866	12.4015	+0	-400

\* If other than a pair of bearings is involved, the tolerances are in proportion to the number of bearings.

## SCHATZ BEARING CORPORATION

A leading producer of high-quality ball bearings and motion control products.

10 Fairview Avenue, Poughkeepsie, New York 12601

Tel: 845.452.6000 • schatzbearing.com • Fax: 845.452.1660

## INNER RING

Specifications for Metric and Inch Ball Bearings (all tolerances shown are in .0001 inch)

Bore Diameter d				Bore Tolerance Limits				Raceway Radial Runout
mm		Inches		d <sub>m</sub>		d <sub>min</sub>	d <sub>max</sub>	
Over	Incl.	Over	Incl.	Low	High			
0	10	0	0.3937	-3	+0	-4	+1	2
10	18	0.3937	0.7087	-3	+0	-4	+1	3
18	30	0.7087	1.1811	-3	+0	-4	+1	3
30	50	1.1811	1.9685	-4	+0	-5	+2	4
50	80	1.9685	3.1496	-4	+0	-6	+2	4
80	120	3.1496	4.7244	-6	+0	-8	+2	5
120	150	4.7244	7.0866	-7	+0	-9	+3	7
150	180	4.7244	7.0866	-7	+0	-9	+3	7
180	250	7.0866	9.8425	-8	+0	-11	+4	8

## OUTER RING

Specifications for Metric and Inch Ball Bearings (all tolerances shown are in .0001 inch)

Bore Diameter d				Outside Diameter Tolerance Limits						Raceway Radial Runout
mm		Inches		D <sub>m</sub>		Open Bearings		Shielded/Sealed Bearings		
Over	Incl.	Over	Incl.	High	Low	D <sub>max</sub>	D <sub>min</sub>	D <sub>max</sub>	D <sub>min</sub>	
0	18	0	0.7078	+0	-3	+1	-4	-2	-5	4
18	30	0.7078	1.1811	+0	-3	+1	-4	+2	-5	4
30	50	1.1811	1.9685	+0	-3	+2	-5	+4	-7	4
50	80	1.9685	3.1496	+0	-4	+2	-6	+4	-8	5
80	120	3.1496	4.7244	+0	-5	+3	-7	+6	-10	7
120	150	4.7244	5.9055	+0	-6	+3	-8	+6	-11	8
150	180	5.9055	7.0866	+0	-7	+3	-9	+6	-12	9
180	250	7.0866	9.8425	+0	-8	+4	-11	+8	-15	10
250	315	9.8425	12.4015	+0	-10	+4	-12	+8	-16	12

## WIDTH TOLERANCES

Specifications for Metric and Inch Ball Bearings (all tolerances shown are in .0001 inch)

Bearings Other Than Duplex Width of Individual Inner or Outer Ring

Duplex Bearings Total Width of Inner or Outer Ring\*

Inner Ring Bore				Width Tolerance Limits		Inner Ring Bore				Width Tolerance Limits	
mm		Inches				mm		Inches			
Over	Incl.	Over	Incl.			Over	Incl.	Over	Incl.		
0	10	0	7.0866	+0	-50	0	80	0	3.1496	+0	-200
180	315	7.0866	12.4015	+0	-100	80	180	3.1496	7.0866	+0	-300
—	—	—	—	—	—	180	315	7.0866	12.4015	+0	-400

\* If other than a pair of bearings is involved, the tolerances are in proportion to the number of bearings.

## SCHATZ BEARING CORPORATION

A leading producer of high-quality ball bearings and motion control products.

10 Fairview Avenue, Poughkeepsie, New York 12601

Tel: 845.452.6000 • schatzbearing.com • Fax: 845.452.1660

## INNER RING

Specifications for Metric and Inch Ball Bearings (all tolerances shown are in .0001 inch)

Bore Diameter d				Bore Tolerance Limits		Raceway Radial Runout*	Width Variation	Face Runout w/Bore*	Raceway Axial Runout*
mm		Inches		d <sub>min</sub>	d <sub>max</sub>				
Over	Incl.	Over	Incl.						
0	10	0	0.3937	-2	+0	1.5	2	3	3
10	18	0.3937	0.7087	-2	+0	1.5	2	3	3
18	30	0.7087	1.1811	-2.5	+0	1.5	2	3	3
30	50	1.1811	1.9685	-3	+0	2	2	3	3
50	80	1.9685	3.1496	-3.5	+0	2	2.5	3	3
80	120	3.1496	4.7244	-4	+0	2.5	3	3.5	3.5
120	150	4.7244	7.0866	-5	+0	3	3	4	4
150	180	4.7244	7.0866	-5	+0	3	3	4	4
180	250	7.0866	9.8425	-6	+0	4	4	4.5	5

## OUTER RING

Specifications for Metric and Inch Ball Bearings (all tolerances shown are in .0001 inch)

Bore Diameter d				Outside Diameter Tolerance Limits						Raceway Radial Runout*	Width Variation	Face Runout w/OD*	Raceway Axial Runout*
mm		Inches		Open Bearings		Shielded/Sealed Bearings							
Over	Incl.	Over	Incl.	D <sub>max</sub>	D <sub>min</sub>	D <sub>m</sub>		D <sub>max</sub>	D <sub>min</sub>				
						High	Low						
0	18	0	0.7078	+0	-2	+0	-2	+1	-3	2	1	3	3
18	30	0.7078	1.1811	+0	-2.5	+0	-2.5	+1	-3.5	2.5	2	3	3
30	50	1.1811	1.9685	+0	-3	+0	-3	+2	-4.5	3	2	3	3
50	80	1.9685	3.1496	+0	-3.5	+0	-3.5	+2	-5.5	3	2	3	4
80	120	3.1496	4.7244	+0	-4	+0	-4	+3	-7	4	3	3.5	4.5
120	150	4.7244	5.9055	+0	-4.5	+0	-4.5	+3	-7.5	4.5	3	4	5
150	180	5.9055	7.0866	+0	-5	+0	-5	+3	-8	5	3	4	5.5
180	250	7.0866	9.8425	+0	-6	+0	-6	+4	-10	6	4	4.5	6
250	315	9.8425	12.4015	+0	-7	+0	-7	+4	-11	7	4.5	5	7

\* with Reference Sides

## WIDTH TOLERANCES

Specifications for Metric and Inch Ball Bearings (all tolerances shown are in .0001 inch)

Bearings Other Than Duplex Width of Individual Inner or Outer Ring						Duplex Bearings Total Width of Inner or Outer Ring*					
Inner Ring Bore				Width Tolerance Limits		Inner Ring Bore				Width Tolerance Limits	
mm		Inches				mm		Inches			
Over	Incl.	Over	Incl.			Over	Incl.	Over	Incl.		
0	10	0	0.3937	+0	-16	0	80	0	3.1496	+0	-200
10	18	0.3937	0.7078	+0	-32	80	180	3.1496	7.0866	+0	-300
18	180	0.7078	7.0866	+0	-50	180	315	7.0866	12.4015	+0	-400
180	315	7.0866	12.4015	+0	-100	—	—	—	—	—	—

\* If other than a pair of bearings is involved, the tolerances are in proportion to the number of bearings.

## SCHATZ BEARING CORPORATION

A leading producer of high-quality ball bearings and motion control products.

10 Fairview Avenue, Poughkeepsie, New York 12601

Tel: 845.452.6000 • schatzbearing.com • Fax: 845.452.1660

## INNER RING

Specifications for Metric and Inch Ball Bearings (all tolerances shown are in .0001 inch)

Bore Diameter d				Bore Tolerance Limits		Raceway Radial Runout*	Width Variation	Face Runout w/Bore*	Raceway Axial Runout*
mm		Inches		d <sub>min</sub>	d <sub>max</sub>				
Over	Incl.	Over	Incl.						
0	10	0	0.3937	-1.5	+0	1	1	1	1
10	18	0.3937	0.7087	-1.5	+0	1	1	1	1
18	30	0.7087	1.1811	-2	+0	1	1	1.5	1.5
30	50	1.1811	1.9685	-2.5	+0	1.5	1	1.5	1.5
50	80	1.9685	3.1496	-3	+0	1.5	1.5	2	2
80	120	3.1496	4.7244	-3	+0	2	1.5	2	2
120	150	4.7244	7.0866	-4	+0	2.5	2	2.5	3
150	180	4.7244	7.0866	-4	+0	2.5	2	2.5	3
180	250	7.0866	9.8425	-4.5	+0	3	2.5	3	3

## OUTER RING

Specifications for Metric and Inch Ball Bearings (all tolerances shown are in .0001 inch)

Bore Diameter d				Outside Diameter Tolerance Limits						Raceway Radial Runout*	Width Variation	Face Runout w/OD*	Raceway Axial Runout*
mm		Inches		Open Bearings		Shielded/Sealed Bearings							
Over	Incl.	Over	Incl.	D <sub>max</sub>	D <sub>min</sub>	D <sub>m</sub>		D <sub>max</sub>	D <sub>min</sub>				
						High	Low						
0	18	0	0.7078	+0	-1.5	+0	-1.5	+1	-2.5	1	1	1.5	2
18	30	0.7078	1.1811	+0	-2	+0	-2	+1	-3	1.5	1	1.5	2
30	50	1.1811	1.9685	+0	-2.5	+0	-2.5	+2	-4.5	2	1	1.5	2
50	80	1.9685	3.1496	+0	-3	+0	-3	+2	-5	2	1	1.5	2
80	120	3.1496	4.7244	+0	-3	+0	-3	+3	-6	2.5	1.5	2	2.5
120	150	4.7244	5.9055	+0	-3.5	+0	-3.5	+3	-6.5	3	2	2	3
150	180	5.9055	7.0866	+0	-4	+0	-4	+3	-7	3	2	2	3
180	250	7.0866	9.8425	+0	-4.5	+0	-4.5	+4	-8.5	4	3	3	4
250	315	9.8425	12.4015	+0	-5	—	—	—	—	4.5	3	3	4

\* with Reference Sides

## WIDTH TOLERANCES

Specifications for Metric and Inch Ball Bearings (all tolerances shown are in .0001 inch)

Bearings Other Than Duplex Width of Individual Inner or Outer Ring						Duplex Bearings Total Width of Inner or Outer Ring*					
Inner Ring Bore				Width Tolerance Limits		Inner Ring Bore				Width Tolerance Limits	
mm		Inches				mm		Inches			
Over	Incl.	Over	Incl.			Over	Incl.	Over	Incl.		
0	10	0	0.3937	+0	-16	0	80	0	3.1496	+0	-200
10	18	0.3937	0.7078	+0	-32	80	180	3.1496	7.0866	+0	-300
18	180	0.7078	7.0866	+0	-50	180	315	7.0866	12.4015	+0	-400
180	315	7.0866	12.4015	+0	-100	—	—	—	—	—	—

\* If other than a pair of bearings is involved, the tolerances are in proportion to the number of bearings.

## SCHATZ BEARING CORPORATION

A leading producer of high-quality ball bearings and motion control products.

10 Fairview Avenue, Poughkeepsie, New York 12601

Tel: 845.452.6000 • schatzbearing.com • Fax: 845.452.1660

Schatz designs and manufactures many different bearing configurations that are used to suit a wide variety of applications. While these configurations are far too numerous to list here, the following section presents a handful of examples of some of the design and materials options that we offer.

Schatz can custom design and manufacture parts and assemblies to meet the specific requirements of your particular application.

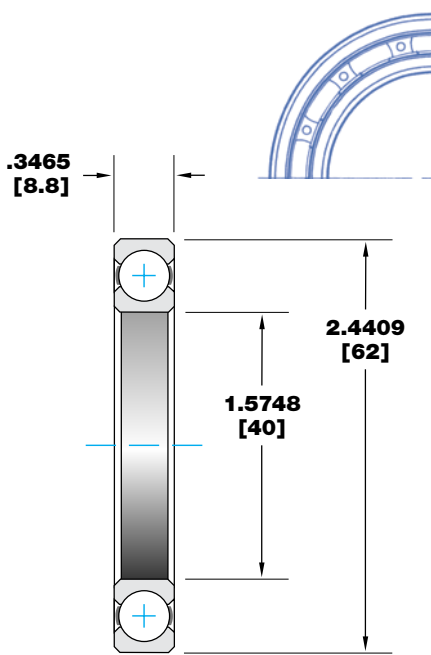

EMS138 stainless steel, for high corrosion resistance, narrow cross section, large ball size for maximum capacity.

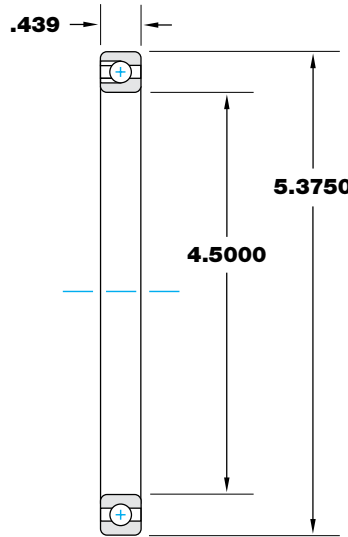

Thin section ball bearing, full complement for high radial capacity.

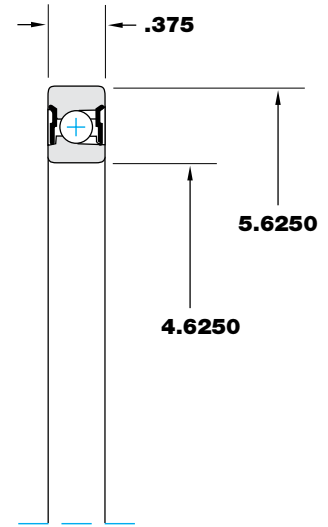

Thin section ball bearing, full complement for maximum radial capacity, shielded.

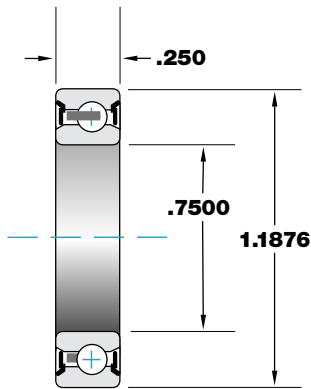

Shielded radial ball bearing, ABEC 5 tolerances, 440C rings and balls, aluminum bronze land riding retainer.

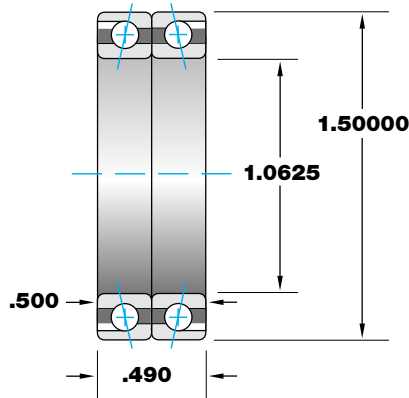

ABEC 5 duplex preloaded pair mounted in DB arrangement, 440C rings and balls, phenolic laminate retainer.

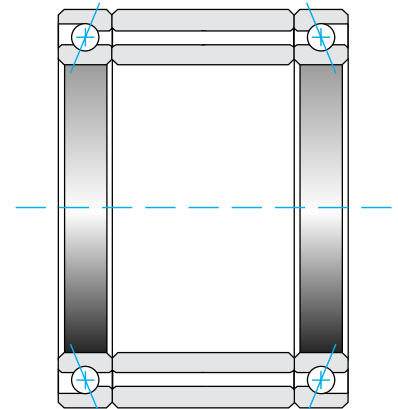

ABEC 5 duplex preloaded pair mounted in DB arrangement with spacers, 440C rings and balls, stainless steel retainer.

## SCHATZ BEARING CORPORATION

*A leading producer of high-quality ball bearings and motion control products.*

10 Fairview Avenue, Poughkeepsie, New York 12601

Tel: 845.452.6000 • [schatzbearing.com](http://schatzbearing.com) • Fax: 845.452.1660

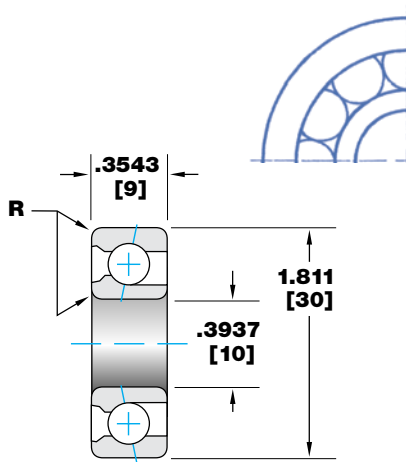

High temperature, angular contact bearing, full compliment, 440C modified rings and balls, operating temperature limit is 850 degrees F.

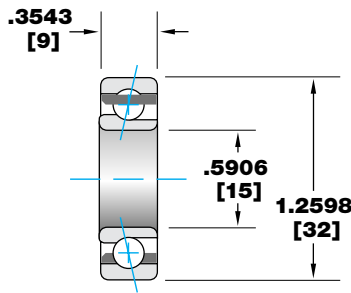

ABEC 5 tolerances, M50 rings and balls, outer ring land riding bronze cage.

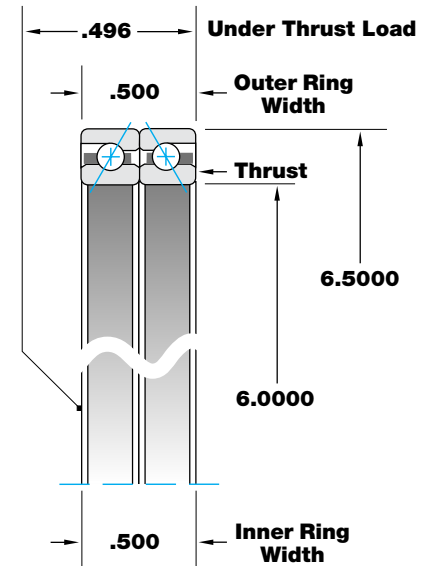

ABEC 5 tolerances, duplex preloaded pair of thin section bearings, mounted in back to back (DB) arrangement. Special cross-corner tolerance to control overall width under load.

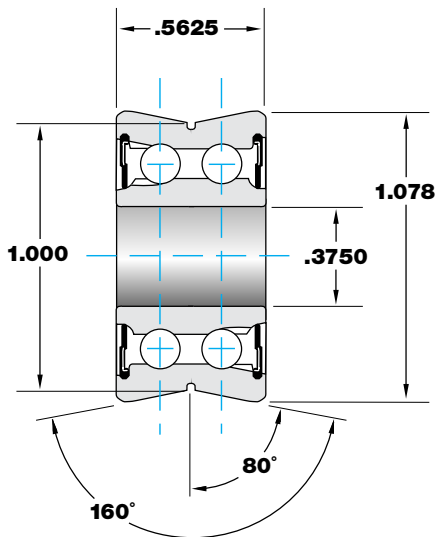

High speed V-Groove track roller, Flouroelastomer seals, ceramic rolling elements, full compliment for high load capacity.

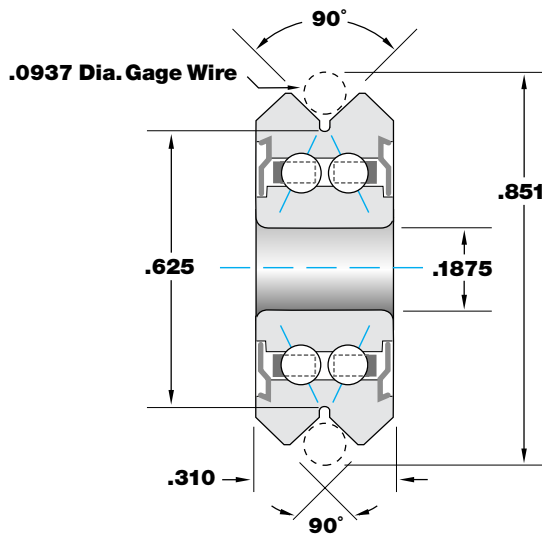

V-Groove track roller, EMS138 stainless rings and balls, high temperature retainer, tungsten disulfide dry film coating on races. Operating temperature limit is 550 degrees F.

## SCHATZ BEARING CORPORATION

A leading producer of high-quality ball bearings and motion control products.

10 Fairview Avenue, Poughkeepsie, New York 12601

Tel: 845.452.6000 • schatzbearing.com • Fax: 845.452.1660



*A leading producer of high-quality ball bearings and motion control products.*



*Thin Section Bearings • Angular Contact Bearings • Double-row Angular Contact Bearings  
Aerospace and Defense • Semiconductor Equipment • Automation Equipment  
Duplex Angular Contact Bearings • Four Point Contact Bearings • Thrust Bearings  
Commercial and Precision Bearings • Guide Wheels, Tracks and Assemblies*

*Radial Ball Bearings  
Precision Bearings  
Linear Motion Products  
Medical Equipment*



10 Fairview Avenue, Poughkeepsie, New York 12601  
Tel: 845.452.6000 • [schatzbearing.com](http://schatzbearing.com) • Fax: 845.452.1660

