

SKF

SKF spherical plain bearings and rod ends

SKF spherical plain bearings and rod ends



Contents

The SKF brand now stands for more than ever before, and means more to you as a valued customer.

While SKF maintains its leadership as the hallmark of quality bearings throughout the world, new dimensions in technical advances, product support and services have evolved SKF into a truly solutions-oriented supplier, creating greater value for customers.

These solutions encompass ways to bring greater productivity to customers, not only with breakthrough application-specific products, but also through leading-edge design simulation tools and consultancy services, plant asset efficiency maintenance programs, and the industry's most advanced supply management techniques.

The SKF brand still stands for the very best in rolling bearings, but it now stands for much more.

SKF – The knowledge engineering company



1 Product information	4
Where self-alignment is called for	4
When flexibility pays	6
An incomparable range	9
Multi-purpose performance	12
2 Recommendations	16
Selection of bearing size	16
Load ratings	16
Basic rating life	17
Load	18
Equivalent dynamic bearing load	18
Equivalent static bearing load	20
Permissible loads for rod ends	20
Requisite bearing size	21
Specific bearing load	21
Mean sliding velocity	21
Basic rating life	24
Sliding contact surface combinations requiring maintenance: steel-on-steel and steel-on-bronze	24
Maintenance-free sliding contact surface combination steel/sinter bronze composite	26
Maintenance-free sliding contact surface combination steel/PTFE fabric	27
Maintenance-free sliding contact surface combination steel/PTFE composite	29
Variable load and sliding velocity	30
Calculation examples	30
Friction	35
Application of bearings	36
Radial location of bearings	36
Axial location of bearings	40
Sealing	43
Designing the bearing arrangement for easy mounting and dismounting	46
Lubrication	48
Spherical plain bearings requiring maintenance	48
Maintenance-free spherical plain bearings	48
Rod ends requiring maintenance	50
Maintenance-free rod ends	50
Maintenance	51
Mounting	52
Spherical plain bearings	52
Rod ends	54
Dismounting	55
Spherical plain bearings	55
Rod ends	55

3 Product data 57

Radial spherical plain bearings requiring maintenance 58
General 58
Steel-on-steel spherical plain bearings
with metric dimensions..... 62
with inch dimensions..... 66
with extended inner ring..... 70
Maintenance-free radial spherical plain bearings 72
General 72
Bearings with sliding contact surface combination
steel/sinter bronze composite 76
steel/PTFE fabric 78
steel/PTFE composite 82
Angular contact spherical plain bearings 86
General 86
Maintenance-free bearings with sliding contact
surface combination steel/PTFE composite 90
Spherical plain thrust bearings 92
General 92
Maintenance-free bearings with sliding contact
surface combination steel/PTFE composite..... 94
Rod ends requiring maintenance 96
General 96
Steel-on-steel rod ends
with female thread.....100
with female thread for hydraulic cylinders102
with male thread104
with cylindrical section welding shank106
with rectangular section welding shank108
Steel-on-bronze rod ends
with female thread.....110
with male thread112
Maintenance-free rod ends114
General114
Maintenance-free rod ends
with female thread, steel/sinter bronze composite 118
with male thread, steel/sinter bronze composite120
with female thread, steel/PTFE fabric122
with male thread, steel/PTFE fabric124
with female thread, steel/PTFE composite.....126
with male thread, steel/PTFE composite128
Special solutions and related products.....130
Plain bearings for road vehicles130
Plain bearings for rail vehicles130
Spherical plain bearings and rod ends for
airframe applications131
Dry sliding bushings and flanged bushings.....132
Dry sliding thrust washers and strip133

SKF – The knowledge engineering company 134

Product information 4 1

Recommendations 16 2

Product data 57 3

Radial spherical plain bearings requiring maintenance 58 3.1

Maintenance-free radial spherical plain bearings 72 3.2

Angular contact spherical plain bearings 86 3.3

Spherical plain thrust bearings 92 3.4

Rod ends requiring maintenance 96 3.5

Maintenance-free rod ends 114 3.6

Special solutions and related products 130 3.7

Where self-alignment is called for

Spherical plain bearings

Spherical plain bearings are standardized, ready-to-mount mechanical components that are self-aligning and enable multi-directional alignment movements to be made. The inner ring has a sphered convex outside diameter and the outer ring a correspondingly sphered but concave inside surface (→ fig 1). The forces acting on the bearing may be static or may occur when the bearing makes oscillating or recurrent tilting and slewing movements at relatively low speeds.

The advantages inherent in the design of spherical plain bearings mean that in practice

- errors of alignment or angular misalignment do not influence bearing life
- deformation of surrounding components in operation has no effect
- edge stresses and excessive stressing of adjacent components do not occur
- operational reliability of lightweight constructions is enhanced
- reasonably wide manufacturing tolerances allow the use of cost-favourable welded constructions

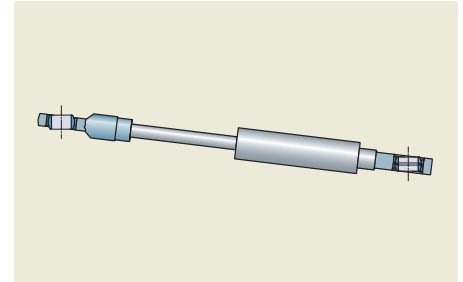
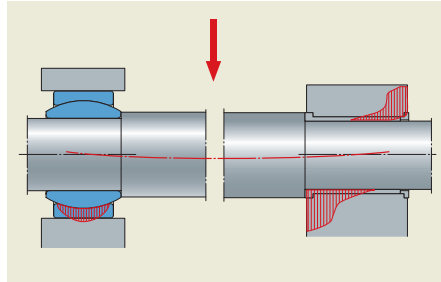

Operational reliability is high even when a design is made more compact – edge stresses and overloading do not occur

Misalignment is not a problem for spherical plain bearings

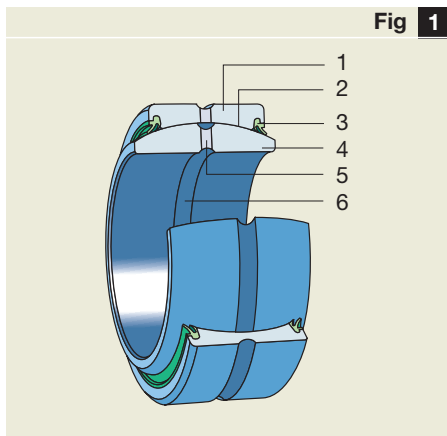
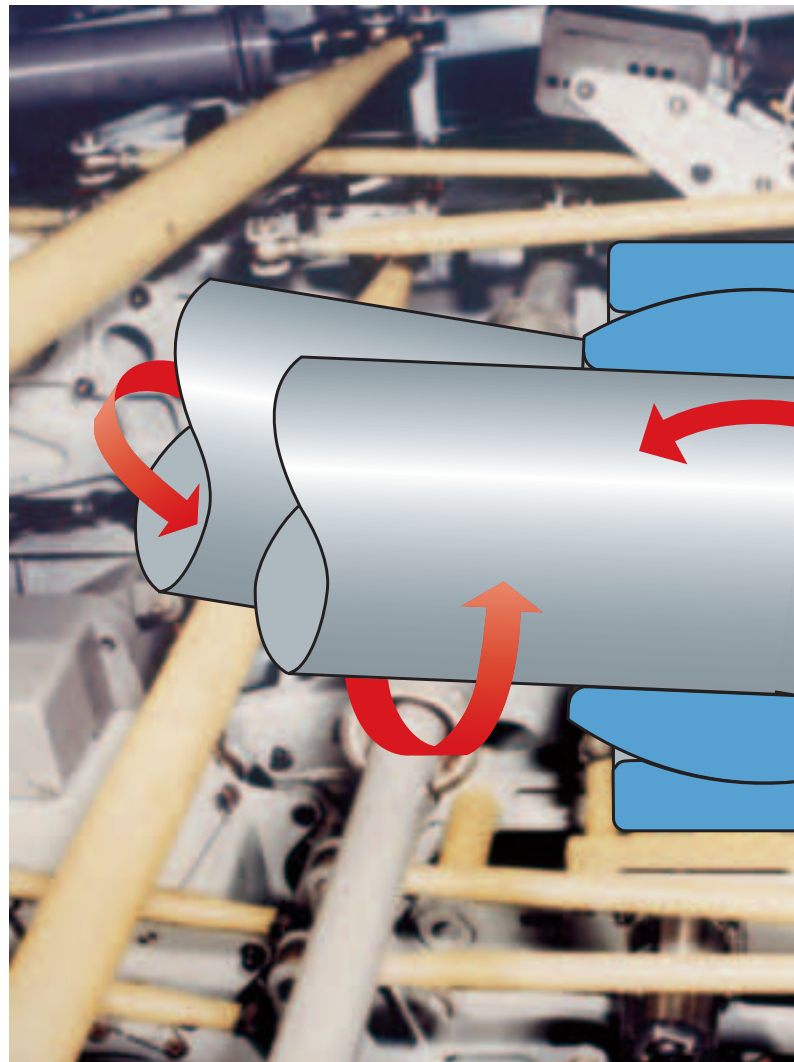
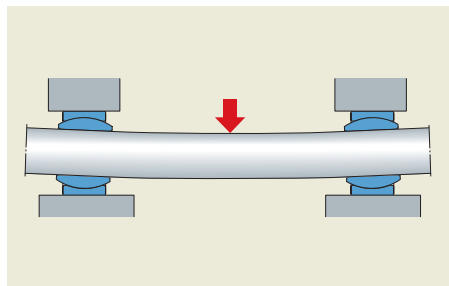

Fig 1

- Spherical plain bearing**
- 1 Outer ring
 - 2 Sliding contact surfaces
 - 3 Seal
 - 4 Inner ring
 - 5 Lubrication hole
 - 6 Lubrication groove





Deformation in operation does not have influence on bearing life

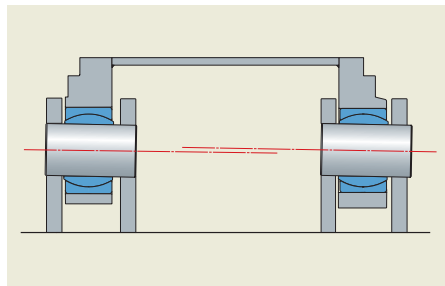

Wide manufacturing tolerances are accommodated = cost-favourable welded constructions

Rod ends

Rod ends are bearing units that consist of a spherical plain bearing in an eye-shaped head with integral shank: the rod end housing (→ fig 2). They are used primarily on the ends of piston rods or together with hydraulic as well as pneumatic cylinders to join the cylinder to associated components.

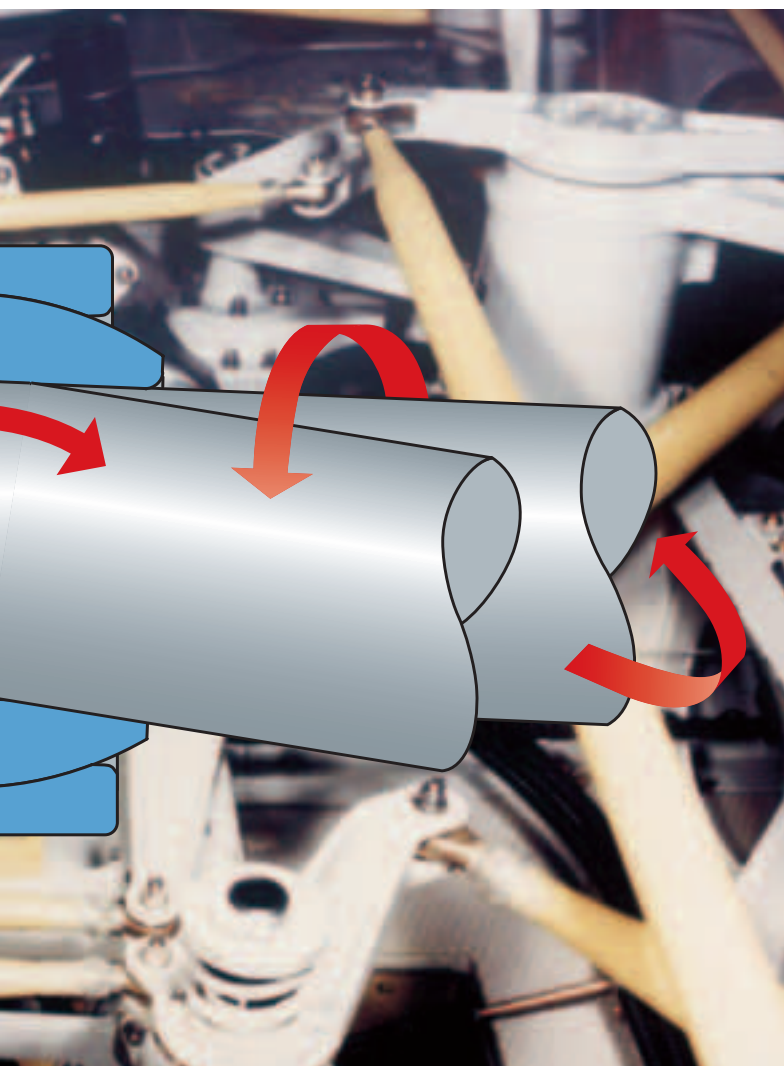

- Rod end**
- 1 Spherical plain bearing
 - 2 Rod end
 - 2a Rod end housing (eye)
 - 2b Rod end shank
 - 3 Lubrication nipple

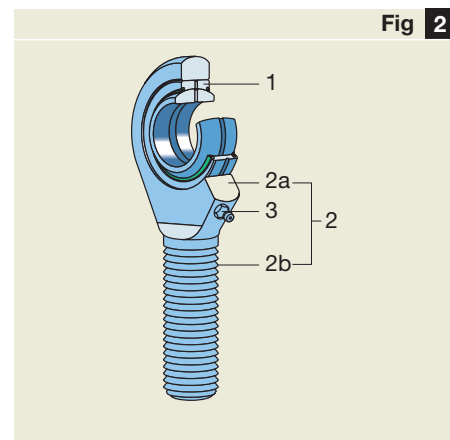

When flexibility pays

SKF spherical plain bearings and rod ends should be the first choice for total design economy. These state-of-the-art products are stocked in a wide range of designs, dimension series and sizes.

Whether a large bearing is required, or a small maintenance-free rod end – both are available from SKF and offer:

- long service life,
- simple maintenance and
- high operational reliability.

Easy replaceability is also provided as all SKF spherical plain bearings and rod ends are standardized products. Their worldwide availability goes without saying – thanks to the global SKF sales organisation.

It is not just total economy considerations that point to SKF spherical plain bearings and rod ends, but also their unparalleled design characteristics. Some of the advantages are outlined in the following.

Mature, well-proven designs

SKF spherical plain bearings and rod ends offer the performance to meet application demands. The designs, materials and manufacturing quality have been selected for long service lives and reliability. “Fit and forget” is a philosophy embraced by SKF.

Easily maintainable sliding contacts for heavy loads

SKF steel-on-steel spherical plain bearings have high-strength sliding contact surfaces of carbon chromium (rolling bearing) steel which are phosphated and treated with a special running-in lubricant. Their prime areas of use are where

- heavy static loads and
- heavy alternating loads and
- high-frequency alignment or oscillating movements

occur.

They are also relatively insensitive to contamination and high temperatures. These advantages come at a price – in this case the need for maintenance.

Therefore, lubrication holes and grooves are provided in both the inner and outer rings of all bearings – with the exception of a few small sizes – to facilitate relubrication. To further enhance lubrication, all bearings having an outside diameter of 150 mm and above incorporate the “multi-groove system” in the sliding surface of the outer ring.

SKF steel-on-bronze rod ends also require maintenance, although requirements are less stringent than for steel-on-steel rod ends, as the emergency running properties are better.

The multi-groove system

Standard steel-on-steel spherical plain bearings that have to perform minor alignment movements under very heavy, constant direction loads have a lubricant starvation problem. The SKF multi-groove system is the answer to this. The multi-groove system

- improves lubricant supply to the loaded zone,
- enlarges the lubricant reservoir in the bearing,
- enables relubrication under load,
- permits extended relubrication intervals and
- provides space for wear particles and contaminants to be deposited

All in all the system improves lubricant distribution in the heavily loaded zone and thus extends the service life and/or maintenance intervals.

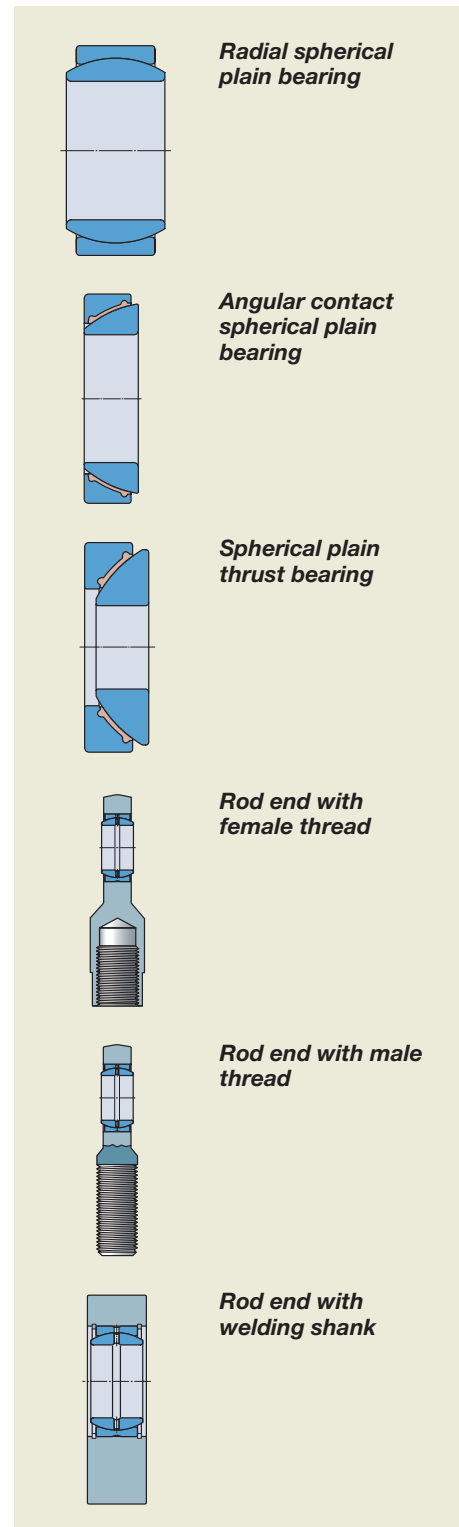

Design features

Maintenance-free, long-life sliding contact surfaces

All freedom, as also freedom from maintenance, has a price. In this case a one-off cost – the purchase price. Once installed, maintenance-free spherical plain bearings and rod ends require no or very little maintenance. The initial higher price is largely compensated by the cost of the maintenance that is avoided. As to offer maintenance-free solutions in a large number of applications SKF produces spherical plain bearings and rod ends with different sliding contact surface combinations (partly size-dependent):

- steel/sinter bronze composite,
- steel/PTFE fabric and
- steel/PTFE composite.

In the first two combinations, the steel is hard chromium plated.

Page 16

The self-lubricating dry sliding materials of the maintenance-free sliding contacts are not as strong as steel and consequently deform more under load. This makes these bearings more sensitive to alternating or “hammering” loads so that steel-on-steel bearings should be used under such conditions. Maintenance-free spherical plain bearings and rod ends are designed for types of duty where

- loads are heavy and are of constant direction, or
- friction should be low and also constant, or
- relubrication is impossible or undesirable.

Page 57



Maintenance-free, long-life sliding contact surfaces
Sinter bronze composite



PTFE fabric

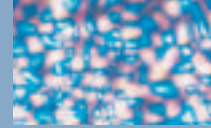

PTFE composite

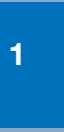

Design features

Page 16

Page 57

Free choice of materials

There is a free choice of materials. In most applications, SKF spherical plain bearings of through hardened steel are the best choice; but in difficult environmental conditions, SKF maintenance-free stainless steel spherical plain bearings may be preferred. Please contact the SKF application engineering service for other options. It is not necessary to be limited or make compromises.

With or without seals

SKF also provides a choice of seals. The most popular sizes of standard bearings are available with and without seals. Sealed bearings provide opportunities to solve many sealing problems simply by using standard bearings, saving space and above all expense. The double lip seal integral with the face of the outer ring efficiently protects the sliding contact surfaces from contaminants in normal environments. If environmental conditions are difficult, the SKF high-performance seals of the LS design should be considered (→ page 44). The operational reliability of the bearing arrangement will be much enhanced – a benefit for original equipment manufacturers as well as their customers.

Wide operating temperature range

Temperature is not a problem. There is a choice of SKF spherical plain bearings and rod ends for temperatures ranging from -50 to +300 °C.

Minimal maintenance

Fit and forget applies to most SKF spherical plain bearings and rod ends. They are maintenance-free. In some applications, where heavy loads and difficult environments prevail, there might be a need for some maintenance. However, this need is minimal for SKF plain bearings, as there is an optimal choice of five different sliding contact surface combinations and also seals executions are available.

Exhaustive range

The SKF range starts with bearings having a 4 mm bore and the rod end range covers almost all normal requirements. More information will be found in the following section.

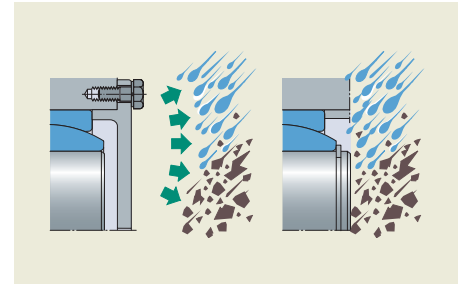

Choice of materials

Bearings of rolling bearing steel for normal conditions and, for difficult environments, bearings of stainless steel

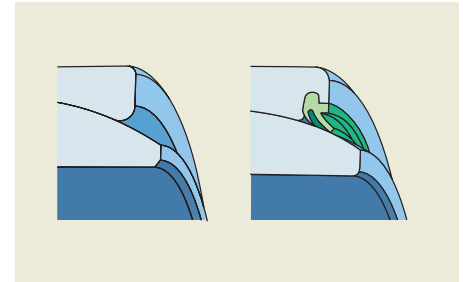

With or without seals

Many sealing problems can be solved economically and in a space-saving manner using sealed bearings that dominate the SKF range

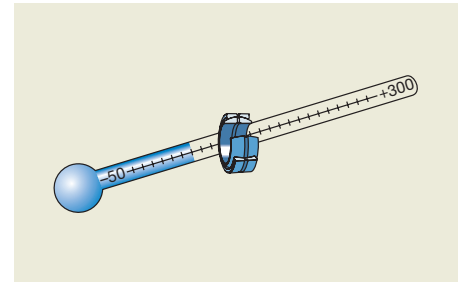

Wide permissible operating temperature range

Open steel-on-steel spherical plain bearings can operate at temperatures ranging from -50 to +300 °C

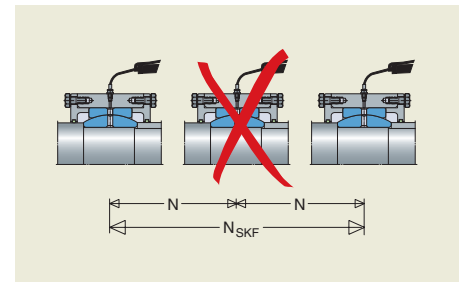

Minimum maintenance

The multi-groove system dramatically extends maintenance intervals for steel-on-steel spherical plain bearings

An incomparable range

1



All the products shown here belong to the SKF standard range.

- Radial spherical plain bearings requiring maintenance
- Maintenance-free spherical plain bearings
- Angular contact spherical plain bearings
- Spherical plain thrust bearings
- Steel-on-steel rod ends requiring maintenance
- Steel-on-bronze rod ends requiring maintenance
- Maintenance-free rod ends

If the standard range does not fulfill the requirements, SKF can produce special bearings, provided quantities permit manufacturing economy. The design will be specially tailored to meet particular application demands. Nothing is too much trouble.

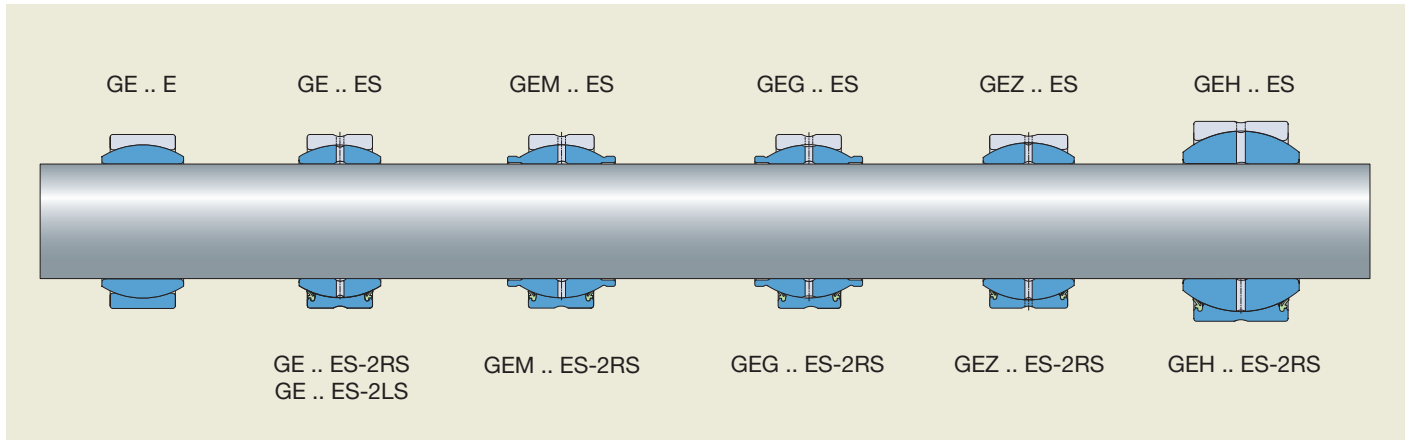

Radial spherical plain bearings requiring maintenance

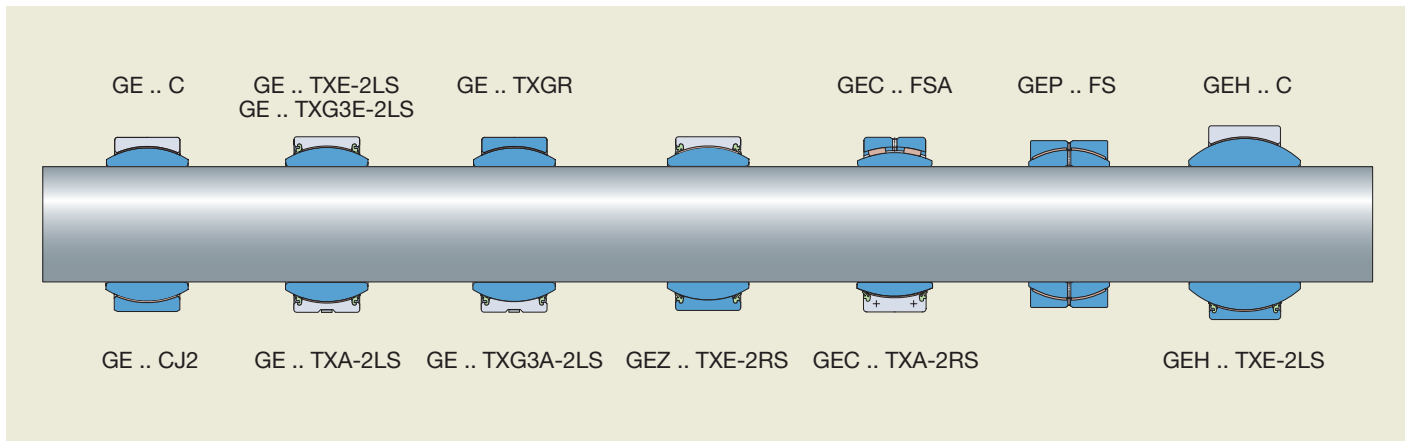

Maintenance-free radial spherical plain bearings

Angular contact spherical plain bearings

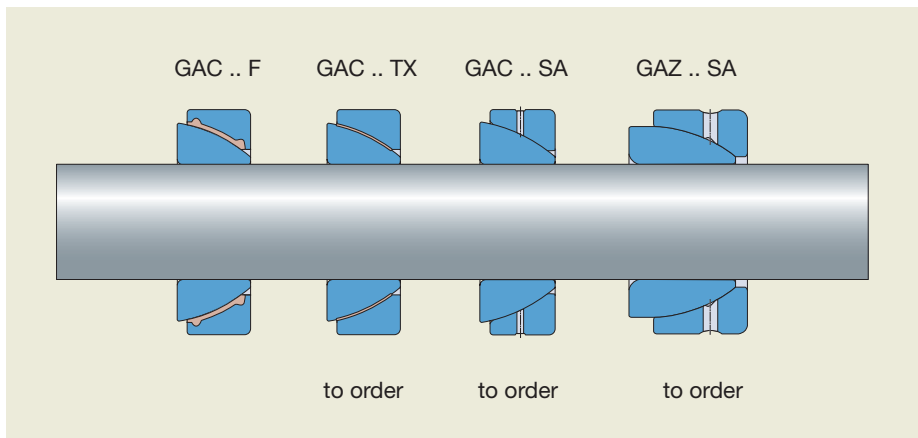

Spherical plain thrust bearings

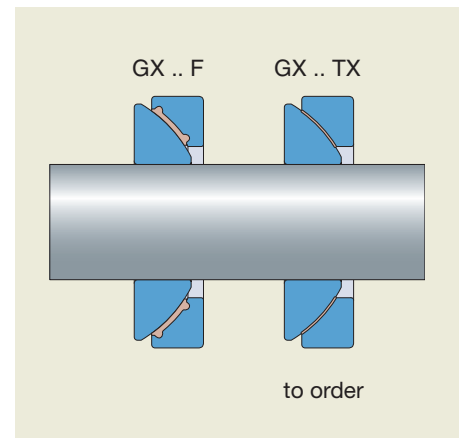

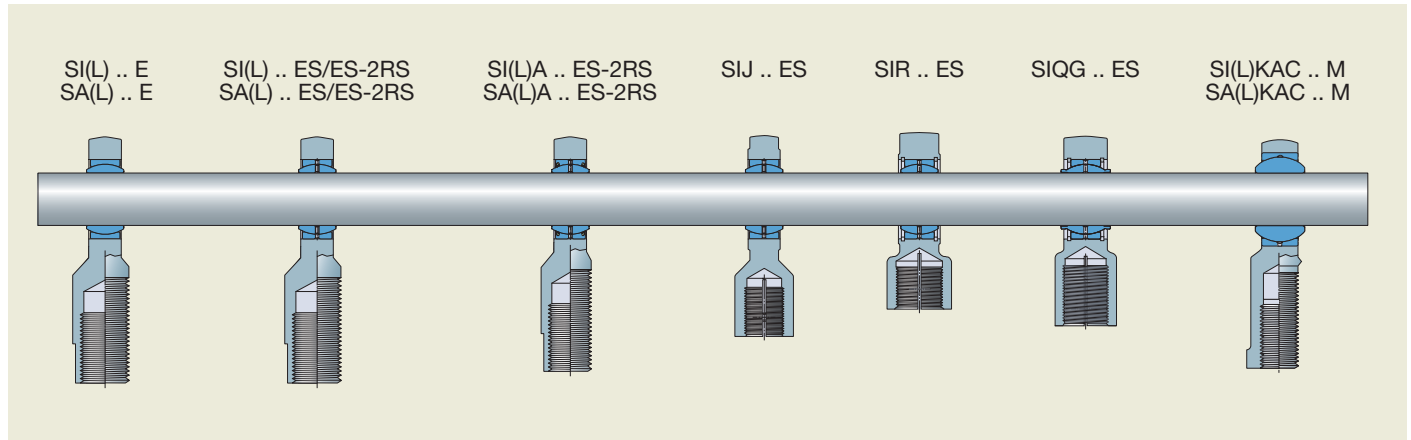

Rod ends with threaded shank requiring maintenance

Designation suffix	Dry sliding surface
C	sinter bronze composite
F	PTFE composite
TX	PTFE fabric, embedded in phenolic or epoxy resin

For detailed information on these materials, see [page 72](#)

Identification of maintenance-free sliding materials

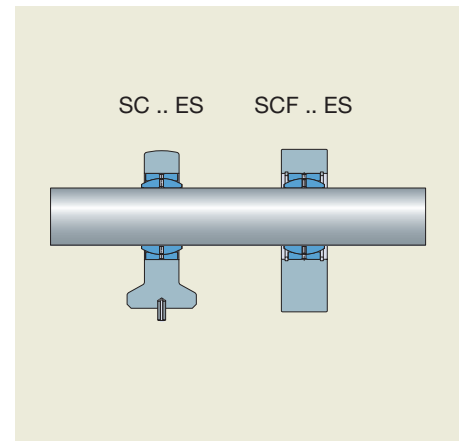

Rod ends with welding shank requiring maintenance

Maintenance-free rod ends with threaded shank

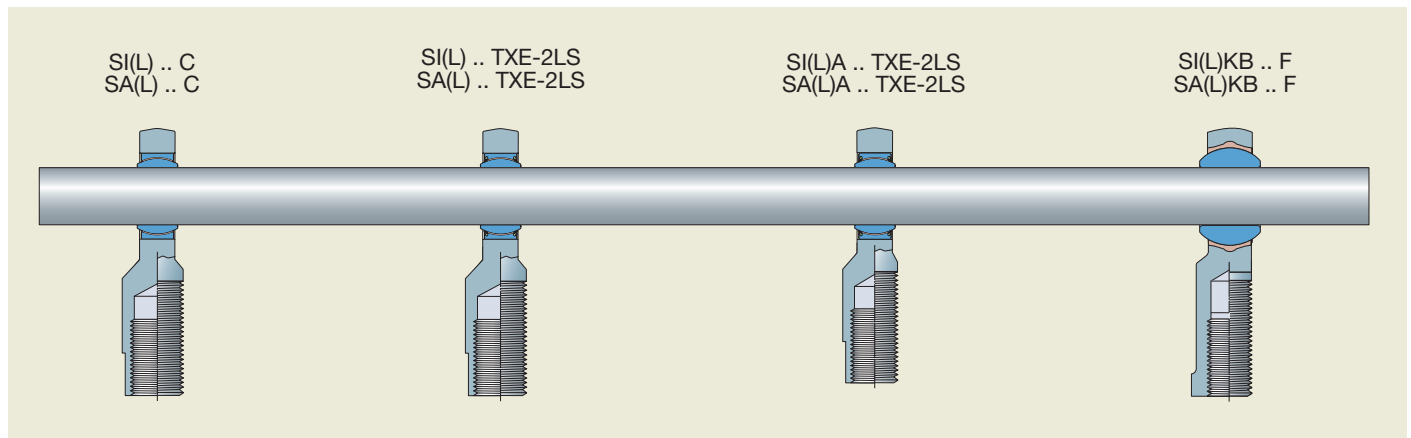

Multi-purpose performance

Long life, high reliability, minimum maintenance and a representative product range are strong arguments for SKF spherical plain bearings and rod ends. As this benefits the user as well as the operator, a wide range of applications in almost all sectors of industry has evolved. Typical use of spherical plain bearings and rod ends requiring maintenance are found in

- the steel construction industry,
- cranes,
- fork lift trucks,
- hydraulic cylinders,
- stabilizers,
- mineral processing equipment,
- rolling mill equipment and
- linkages of all kinds in construction and earth-moving machines and equipment.

Application areas where maintenance-free spherical plain bearings and rod ends are used include

- conveyors,
- industrial robots,
- textile and printing machinery,
- switching levers,
- packaging as well as food and beverage treatment machines, and last but not least
- the many uses in segment gates, barrages and similar installations.

SKF spherical plain bearings and rod ends are in use around the world. Some well-proven applications are shown in the following as examples.

Suspended roof

SKF steel-on-steel spherical plain bearings have been in service in an unusual, but world-renowned application for more than 30 years – the roof of the Olympia Stadium in Munich. Although this type of bearing requires maintenance, none has been given to these particular bearings.

The roof is constructed of a number of prestressed steel ropes in a network. At the torque-free nodal points of the network 225 completely normal SKF steel-on-steel spherical plain bearings having bore diameters ranging from 160 to 300 mm do their duty. The nodes are statically loaded but must allow occasional oscillations of the roof construction.

What better proof could there be for staying power, robustness and longevity?

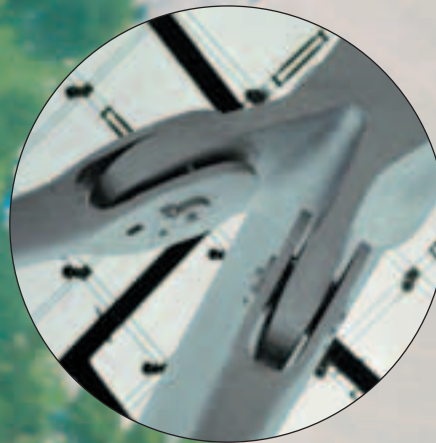

Nodal point of suspended roof construction

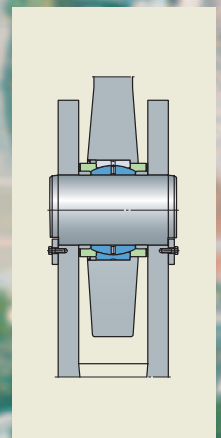

Articulated pendulum joint of a wheel loader

Three SKF steel-on-steel spherical plain bearings with the multi-groove lubrication system are used for the bearing arrangement of the articulated pendulum joint of this wheel loader. Two of the bearings provide the articulation. The third bearing together with a cylindrical sliding bushing in the pendulum joint serves to compensate for uneven ground so that the driven wheels adhere well to the surface.

The multi-groove lubrication system of SKF spherical plain bearings improves the transport of lubricant to the loaded zone and also enlarges the lubricant reservoir in the bearing. Neglection of lubrication intervals

previously led to lubricant starvation, this has been solved.

Heavy-duty performance at no extra cost provides much extended service lives even with long maintenance intervals.



Articulated pendulum joint of a wheel loader

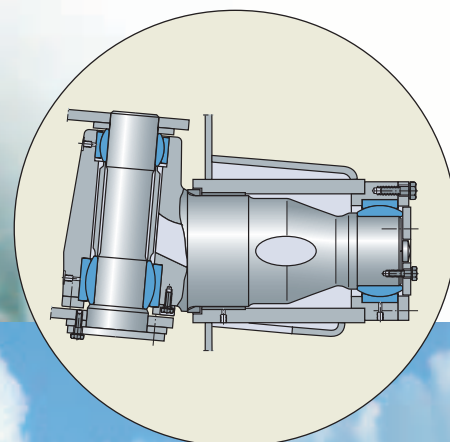

Truck twin-axle supports

The purpose of the bearing arrangement of a truck twin-axle support is to provide even load distribution between the two axles on bumpy roads or off-highway. This means that the arrangement is subjected to heavy loads and, depending on the road/off-highway conditions, heavy shock loads and highly frequent alignment movements. The bearings are hidden behind the tyres and are difficult to access. It is evident that any sudden bearing damage, calling for immediate on site repairs need to be avoided.

A pair of SKF angular contact spherical plain bearings mounted back-to-back make sure that such emergencies will not occur. They can withstand all the rigours of truck duty, are simple to install and also to maintain.

Dam gate

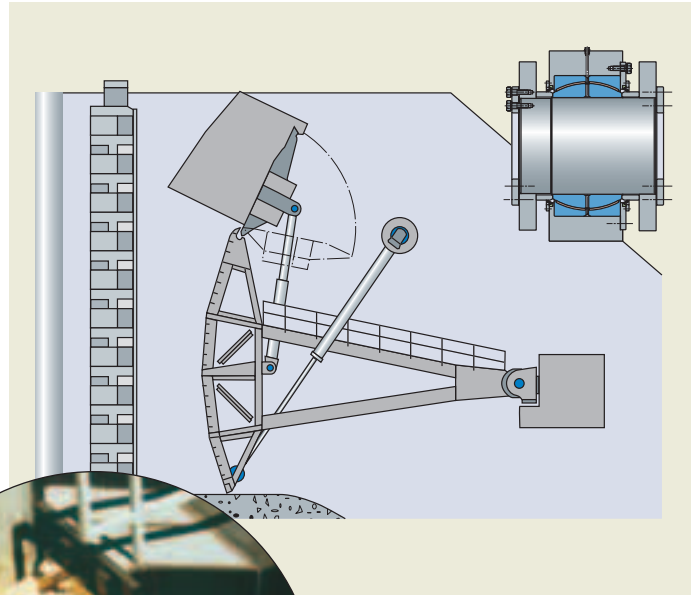

Dam gates

Segment gates for dam barrages are the home of large-size SKF maintenance-free spherical plain bearings. The reference list is long – over 3 000 applications being included to date.

As main bearings, they compensate for non-alignment of their seatings, alterations in length as a result of temperature changes, elastic deformation of the dam gates as well as changes caused by settling of the foundations. They cope with the heavy radial loads caused by the water pressure as well as axial loads arising from the inclined position of the support arms.

SKF bearings not only serve as heavily loaded bearings under static conditions; they also serve in the frequently operated linkage attachments of the lifting and plunger cylinders as well as the flaps.

Truck twin-axle support

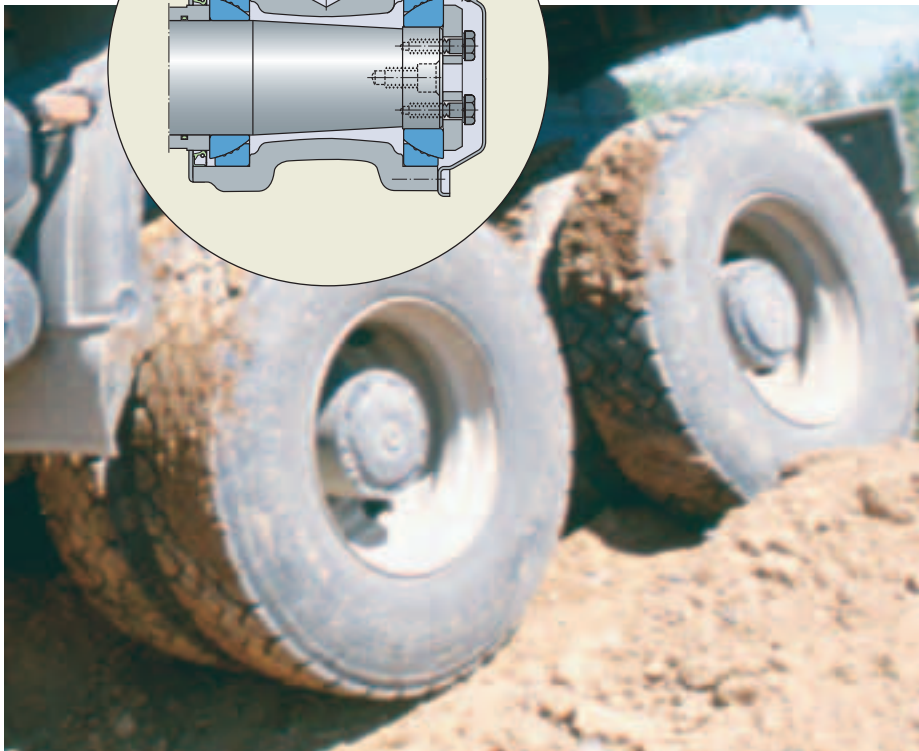
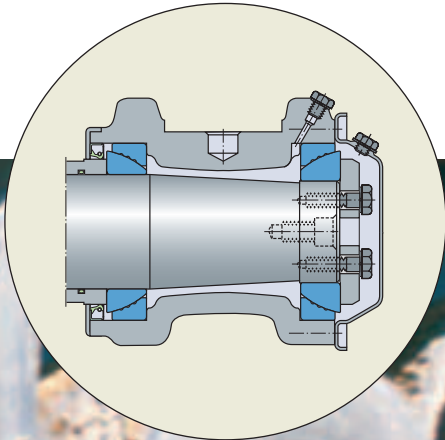

Application areas

Page 16

Page 57

Hydraulic and pneumatic cylinders

SKF steel-on-steel and steel-on-bronze rod ends are mainly used in these applications. They act as the link between the cylinder and its attachments. They are able to transmit high mechanical forces.

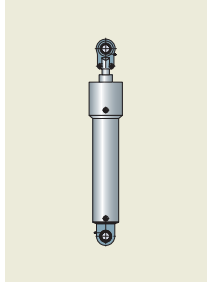

For pneumatic cylinders with working pressures up to approximately 1 MPa steel-on-bronze rod ends are mainly used as well as maintenance-free rod ends at the piston rod end and at the other end SKF rod ends with welding shank are employed.

Hydraulic cylinders (e.g. to DIN 24336) are often fitted with steel-on-steel rod ends with female thread (compressible) at one end and steel-on-steel rod ends with welding shank at the other. Such hydraulic cylinders are found in all types of construction equipment, agricultural machinery, lifting equipment and shutters, recycling depot presses as well as other heavily loaded manoeuvring equipment.

Newspaper conveyor

Speed is all-important when producing newspapers, not only in the printing but also in their transportation. The conveyor system from the printing press to the distribution point is therefore important if the newspapers are to come out on time.

The endless conveyor chain is one such system. It consists of a multitude of links which together provide the flexibility required. In the example shown more than 1 000 SKF maintenance-free spherical plain bearings GEH 10 C are used. They have been in daily service without any maintenance whatsoever for many years now.

Hydraulic and pneumatic cylinders



Newspaper conveyor

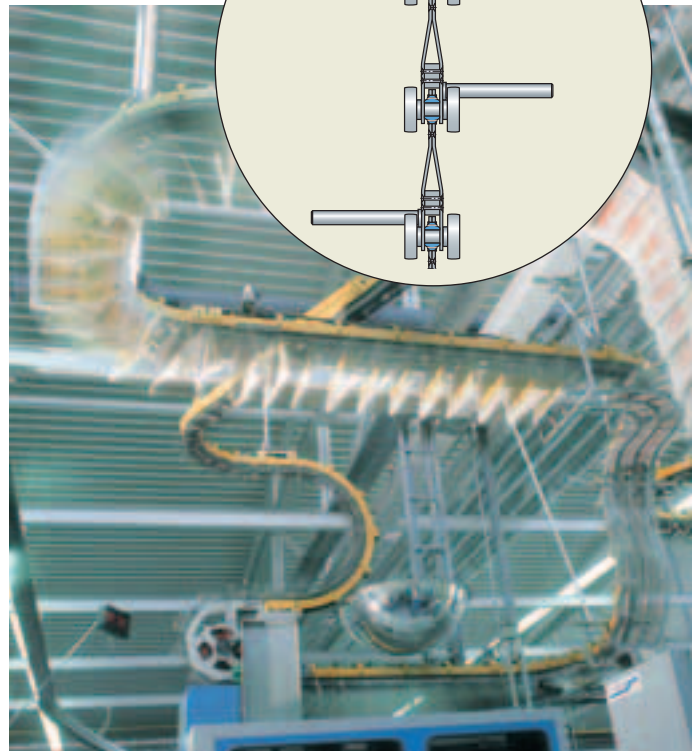

Selection of bearing size

Load ratings

There is no standardized method for determining the load ratings of spherical plain bearings and rod ends, nor is there any standardized definition.

As different manufacturers define load ratings differently, it is not possible to compare the load ratings of bearings produced by one manufacturer with those published by another manufacturer.

Basic dynamic load rating

The basic dynamic load rating C is used, together with other influencing factors, to determine the basic rating life of spherical plain bearings and rod ends. As a rule it represents the maximum load that a spherical plain bearing or rod end can sustain at room temperature when the sliding contact surfaces are in relative motion (→ fig 1). The maximum permissible load in any individual application should always be considered in relation to the de-

sired rating life. The basic dynamic load ratings quoted in the product tables are based on the specific load factor K (→ Table 4, page 21) and the effective projected sliding surface.

Basic static load rating

The basic static load rating C_0 represents the maximum permissible load that may be applied to a bearing when there is no relative movement of the sliding contact surfaces (→ fig 2).

For spherical plain bearings the basic static load rating represents the maximum load which the bearing can accommodate at room temperature without its performance being impaired as a result of inadmissible deformations, fracture or damage to the sliding contact surfaces. The basic static load ratings quoted for SKF spherical plain bearings are based on a specific static load factor K_0 (→ Table 4, page 21) and the effective projected sliding surface. It is assumed that the bearing is adequately supported by

the associated components of the bearing arrangement. In order to fully exploit the static load rating of a spherical plain bearing it is generally necessary to use shafts and housings of high-strength materials. The basic static load rating must also be considered when bearings are dynamically loaded if they are also subjected to additional heavy shock loads. The total load in such cases must not exceed the basic static load rating.

For rod ends it is the strength of the eye-shaped head of the rod end (housing) at room temperature under a constant load acting in the direction of the shank axis which is the determining factor. The basic static load rating represents a safety factor of at least 1,2 relative to the yield strength of the material of the rod end head under the above conditions.

Dynamic bearing load

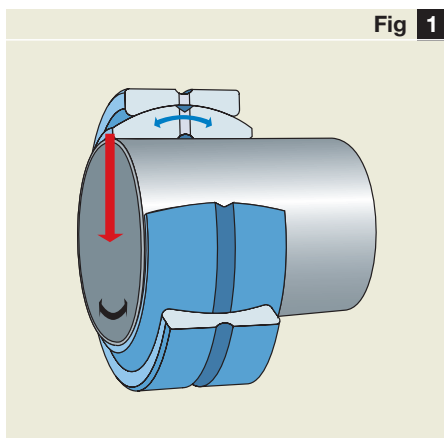

Fig 1

Static bearing load

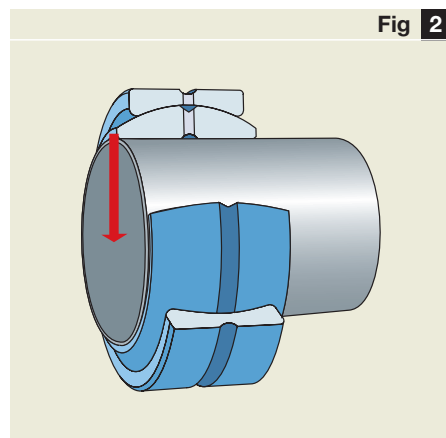

Fig 2

Angle of oscillation

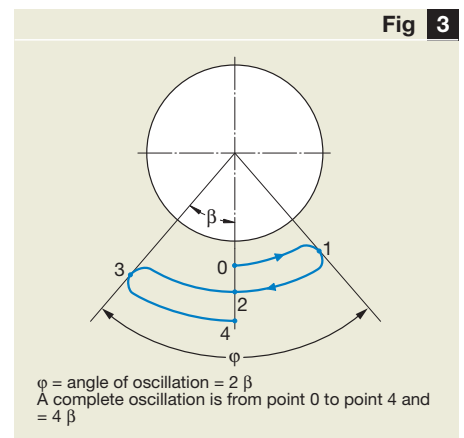

Fig 3

Basic rating life

Spherical plain bearings belong to the category “dry sliding bearings”. In contrast to, say, hydrodynamic plain bearings, no lubricant film can form to fully separate the sliding surfaces. Therefore, under dynamic loads wear is naturally produced which enlarges the internal clearance.

The service life of a spherical plain bearing or rod end represents the operating period under test conditions which is ended when one of the criteria listed in **Table 1** for the end of service life is reached. The life is expressed either in operating hours or in the number of oscillating movements (→ **fig 3**). A distinction is made between the

basic rating life and the service life actually achieved.

The basic rating life is a guideline value which will be attained or exceeded by the majority of a large number of apparently identical bearings under the same test conditions.

The service life achieved by identical bearings has been found to differ, as the service life depends on the actual operating conditions. These include not only the magnitude and type of load but also other factors such as contamination, corrosion, load and movement cycles of high frequency, and shock loads. These factors are difficult or even impossible to quantify.



Calculation of basic rating life

By using the SKF Interactive Engineering Catalogue it is possible to perform all the necessary calculations for spherical plain bearing selection at the click of a mouse using the programs incorporated in the catalogue. The product data necessary for the calculations is automatically put in by selecting a spherical plain bearing or rod end from the product tables. It is then only necessary to fill in the fields for the operating data.

The SKF Interactive Engineering Catalogue is available on CD-ROM or online at www.skf.com.

Criteria for end of service life

Table 1

Sliding contact surface combination	Increase in bearing clearance	Coefficient of friction μ
–	mm	–
Steel-on-steel	> 0,004 d_k	0,20
Steel-on-bronze	> 0,004 d_k	0,25
Steel/sinter bronze composite		
constant direction load	0,2	0,20
alternating direction load	0,4	0,20
Steel/PTFE fabric		
constant direction load	0,3	0,20
alternating direction load	0,6	0,20
Steel/PTFE composite	design and size dependent	0,25

Load

When considering load, a distinction is made between:

- load direction
 - radial loads (→ **fig 4**)
 - axial loads (→ **fig 5**)
 - combined (axial and radial) loads (→ **fig 6**)
- the way in which the load acts
 - loads of constant direction (→ **fig 7**), i.e. the direction in which the load is applied does not change and the same part of the bearing (loaded zone) is always subjected to the load
 - alternating loads (→ **fig 8**), change direction so that loaded zones at opposite positions in the bearing are continuously loaded and unloaded
- the type of load
 - dynamic load is when sliding movement takes place in the loaded bearing
 - static load is when no movement takes place in the loaded bearing.

Equivalent dynamic bearing load

If the load acting on

- radial and angular contact spherical plain bearings is purely radial
- spherical plain thrust bearings is purely axial
- rod ends is purely radial and also in the direction of the shank axis

and is of constant magnitude, then the load can be directly inserted in the equation for the specific bearing load p (→ **page 21**). In all other cases it is necessary to calculate the equivalent dynamic bearing load P . If the load is not of constant magnitude, then the procedure given under “Variable load and sliding velocity” (→ **page 30**) should be followed.

Radial load

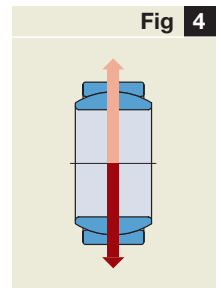

Axial load

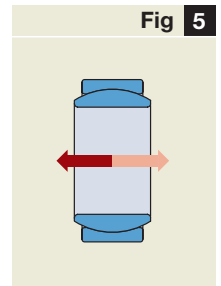

Combined load

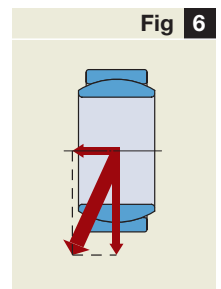

Constant direction load

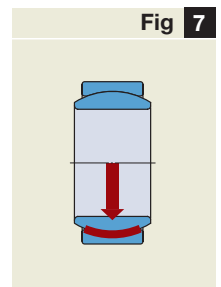

Alternating direction load

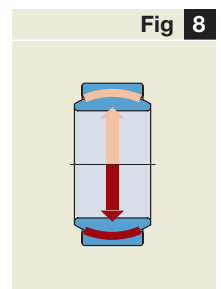

Radial spherical plain bearings

Radial spherical plain bearings can accommodate a certain amount of axial load F_a in addition to the simultaneously acting radial load F_r (→ fig 6). When the resultant load is constant in magnitude, the equivalent dynamic bearing load can be obtained from

$$P = y F_r$$

where

P = equivalent dynamic bearing load, kN

F_r = radial component of the load, kN

- y = a factor that depends on the ratio of the axial to the radial load F_a/F_r
 - for bearings requiring maintenance (→ Diagram 1)
 - for maintenance-free bearings (→ Diagram 2)

Diagram 1

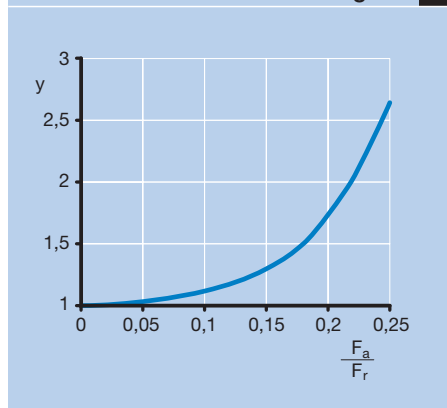

Factor y for radial spherical plain bearings requiring maintenance

Factor y for maintenance-free radial spherical plain bearings

Diagram 2

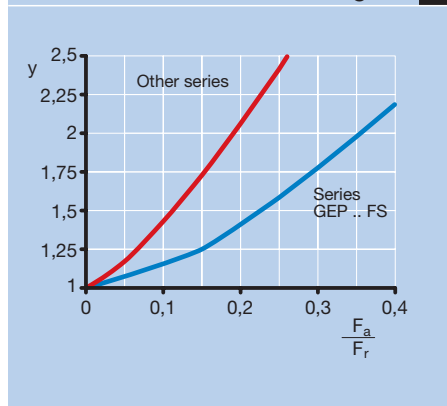

Angular contact spherical plain bearings

When the resultant load (→ fig 9) is constant in magnitude, then

$$P = y F_r$$

where

P = equivalent dynamic bearing load, kN

F_r = radial component of the load, kN

- y = a factor that depends on the ratio of the axial to the radial load F_a/F_r (→ Diagram 3)

Fig 9

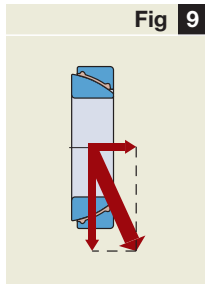

Angular contact spherical plain bearing under combined load

Spherical plain thrust bearings

Spherical plain thrust bearings can carry a radial load F_r in addition to the axial load F_a . However, the radial load must not exceed 50 % of the simultaneously acting axial load (→ fig 10). When the resultant load is constant in magnitude, then

$$P = y F_a$$

where

P = equivalent dynamic bearing load, kN

F_a = axial component of the load, kN

- y = a factor depending on the ratio of the radial to the axial load F_r/F_a (→ Diagram 4)

Fig 10

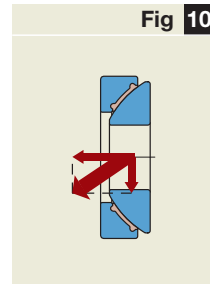

Spherical plain thrust bearing under combined load

Factor y for angular contact spherical plain bearings

Diagram 3

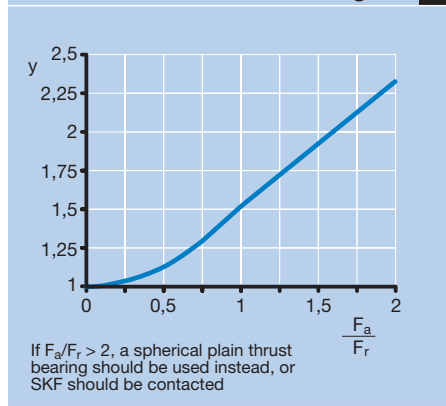

Factor y for spherical plain thrust bearings

Diagram 4

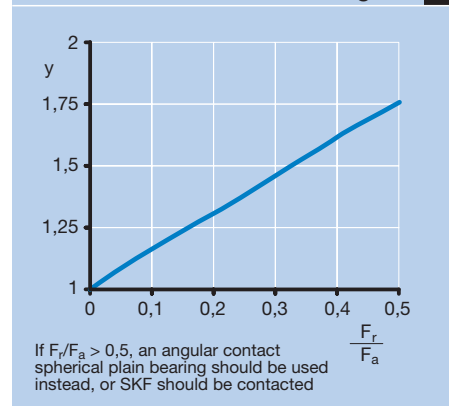

Equivalent static bearing load

If spherical plain bearings and rod ends are subjected to load when stationary or making only slight alignment movements, then the permissible load is not limited by wear, but by the strength of the sliding contact layer or the strength of the rod end housing. If the actual load is a combined radial and axial load, then an equivalent static bearing load must be calculated. This can be done in a similar way to the calculation of the equivalent dynamic bearing load, for radial and angular contact spherical plain bearings using

$$P_0 = y F_r$$

and for spherical plain thrust bearings using

$$P_0 = y F_a$$

where

P_0 = equivalent static bearing load, kN
 F_r = the radial component of the load, kN

F_a = the axial component of the load, kN

y = a factor which depends on the ratio F_a/F_r

- for radial bearings requiring maintenance (→ **Diagram 1**, page 19)
 - for maintenance-free radial bearings (→ **Diagram 2**, page 19)
 - for angular contact spherical plain bearings (→ **Diagram 3**, page 19)
- and on the ratio F_r/F_a
- for spherical plain thrust bearings (→ **Diagram 4**, page 19)

Permissible loads for rod ends

Rod ends are primarily intended for the support of radial loads acting in the direction of the shank axis. If loads act at right angles to the shank axis (→ **fig 11**), the maximum permissible load will be reduced as additional bending stresses occur in the shank. When checking, consideration should also be paid to the rod end head (housing) material which differs depending on design and size.

The load directed at an angle or axially to the rod end (to the direction of the shank axis) should never exceed the value of 0,1 C_0 . If heavier loads are involved then a larger rod end should be chosen.

The maximum permissible load for a rod end in the direction of the shank axis can be calculated from

$$P_{perm} = C_0 b_2 b_6$$

where

P_{perm} = maximum permissible load, kN

C_0 = static load rating, kN

b_2 = temperature factor

- for rod ends requiring maintenance (→ **Table 5**, page 24)
- for maintenance-free rod ends with the sliding contact surface combination
 - steel/sinter bronze composite (→ **Diagram 16**, page 26)
 - steel/PTFE fabric (→ **Diagram 17**, page 27)
 - steel PTFE composite (→ **Diagram 19**, page 29)

b_6 = factor for the type of load (→ **Table 2**)

Fig 11

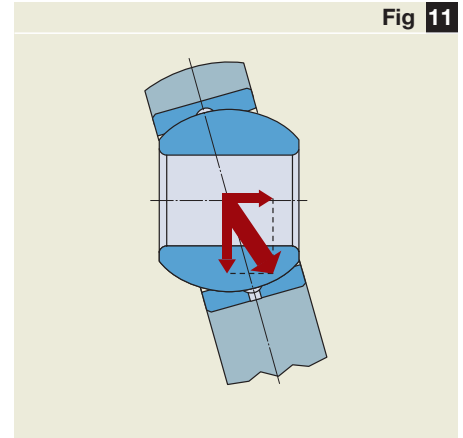

Rod end under combined load

Factor b_6 for rod end load type

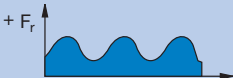
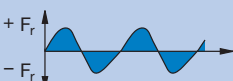
Table 2	
Type of load (magnitude and direction)	Factor b_6
Constant 	1
Pulsating magnitude (single direction) 	0,5 (0,35)
Alternating direction, 	0,5 (0,35)

The values in brackets apply to rod ends with lubrication hole or nipple

Requisite bearing size

When determining the requisite size of bearing (or rod end), it is necessary to know the basic rating life required for the particular application. This is dependent on the type of machine, the operating conditions and the demands regarding operational reliability.

As a first approximation the guideline values of the load ratio C/P given in **Table 3** can be used to obtain the requisite basic dynamic load rating C. A suitable bearing or rod end can then be selected from the product tables.

It should then be checked whether the chosen size can be used under the actual load and sliding velocity conditions using the appropriate diagram for the sliding contact surface combination from those shown on **pages 22 and 23** (**Diagrams 5 to 10** inclusive). The specific bearing load p and the sliding velocity v needed to perform this check can be calculated as explained in the following sections.

If, having checked the pv diagram, it is found that the bearing or rod end can be used, then the basic rating life

Guideline values for C/P

Table 3	
Spherical plain bearings/rod ends with sliding contact surface combination	Load ratio C/P
Steel-on-steel	2
Steel-on-bronze	2
Steel/sinter bronze composite	1,6
Steel/PTFE fabric	2
Steel/glass fibre reinforced plastic	
GAC .. F	1,25
GX .. F	1,25
GEP .. FS	1,6
GEC .. FSA	1,6
Rod ends	1,25

is calculated. If the calculated rating life is shorter than the requisite rating life, a larger bearing or rod end should be chosen and the calculation repeated.

If, on the other hand, the first check shows the pv range is exceeded, a bearing having higher load carrying capacity should be chosen.

The bearing (or rod end) size is often dictated to a greater or lesser degree by the dimensions of the associated components. In such cases the pv diagram should be consulted first to check that the product can be used.

Specific load factors

Table 4		
Sliding contact surface combination	Specific load factors	
	dyn. K	stat. K ₀
–	N/mm ²	
Steel-on-steel		
Metric sizes	100	500
Inch sizes	100	300
Steel-on-bronze	50	80
Steel/sinter bronze composite	100	250
Steel/PTFE fabric	300	500
Steel/glass fibre reinforced plastic		
GAC .. F	50	80
GX .. F	50	80
GEP .. FS	80	120
GEC .. FSA	80	120
Rod ends	50	80

Specific bearing load

The magnitude of the specific bearing load can be determined using

$$p = K \frac{P}{C}$$

where

p = specific bearing load, N/mm²
 K = a specific load factor depending on the basic dynamic load rating

(→ **Table 4**), N/mm²

P = equivalent dynamic bearing load, kN

C = basic dynamic load rating, kN

Mean sliding velocity

The mean sliding velocity for constant movement can be obtained from

$$v = 5,82 \times 10^{-7} d_m \beta f$$

where

v = mean sliding velocity, m/s

When operation is intermittent (not continuous) the mean sliding velocity should be calculated for a cycle of operation

d_m = mean diameter of inner ring or shaft washer, mm

d_m = d_k for radial spherical plain bearings

d_m = 0,9 d_k for angular contact spherical plain bearings

d_m = 0,7 d_k for spherical plain thrust bearings

β = half the angle of oscillation (→ **fig 3**, **page 16**), degrees

For rotation β = 90°

f = frequency of oscillation, min⁻¹, or rotational speed, r/min

For intermittent movement, the angle of oscillation is usually given per unit time. In this case the mean sliding velocity can be calculated using

$$v = 8,73 \times 10^{-6} d_m \frac{2 \beta}{t}$$

where

β = half the angle of oscillation, degrees

t = time taken to pass through 2 β (= whole angle of oscillation), s

Diagram 5

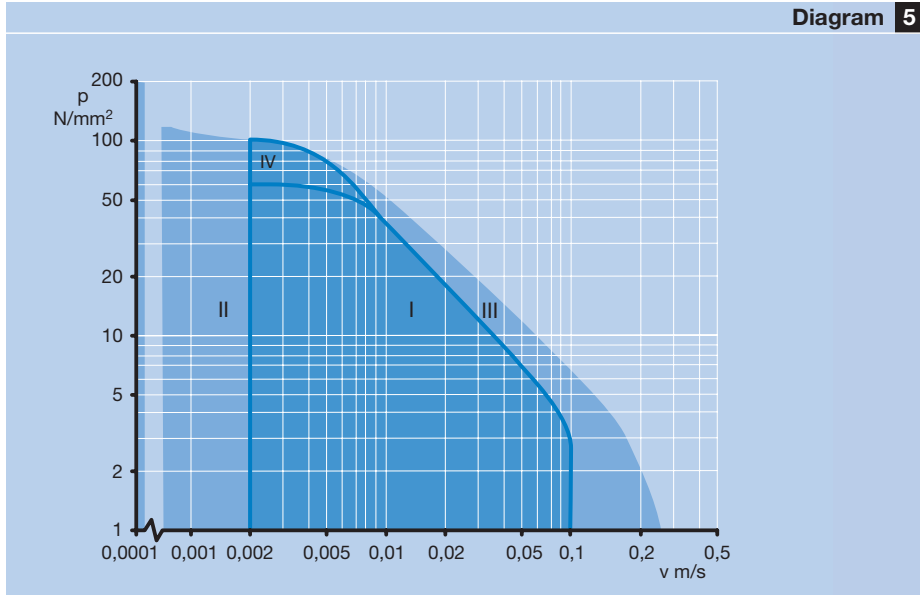

pv diagram for sliding contact surface combination steel-on-steel
See Note 1 for explanation of operating ranges

Diagram 6

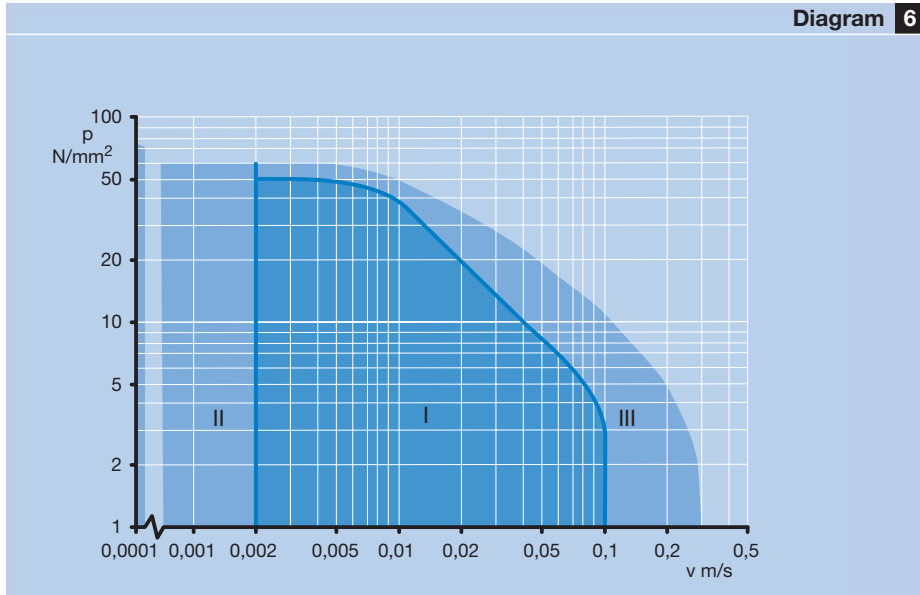

pv diagram for sliding contact surface combination steel-on-bronze
See Note 1 for explanation of operating ranges

Diagram 7

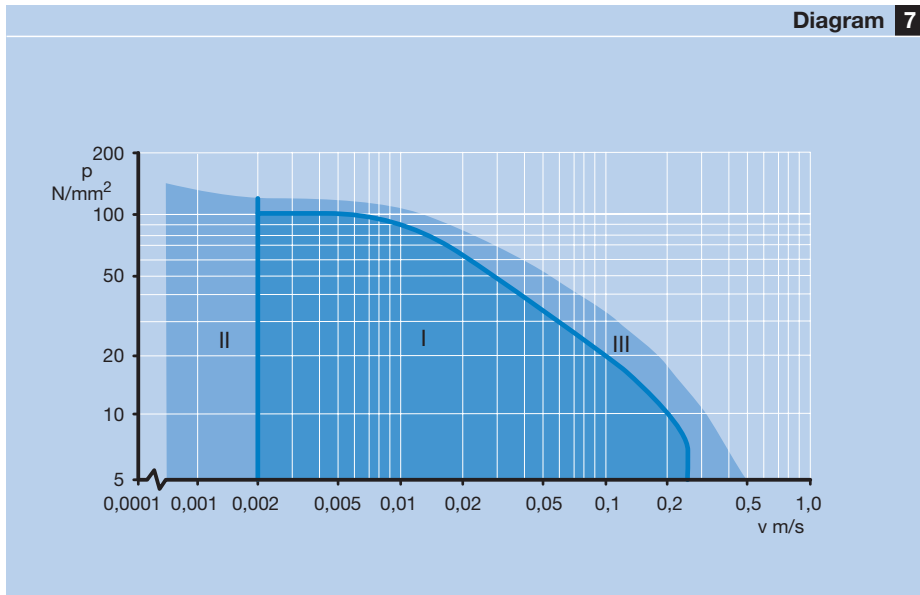

pv diagram for sliding contact surface combination steel/sinter bronze composite
See Note 2 for explanation of operating ranges

Note 1

- pv operating ranges
- I Range where rating life equation is valid
- II Quasi-static range; before using the rating life equation, please contact SKF
- III Possible range of use, e.g. with very good lubrication; before using the rating life equation, please contact SKF
- IV Extended range where rating life equation is valid provided the load is exclusively alternating

pv diagram for sliding contact surface combination steel/PTFE fabric
See Note 2 for explanation of operating ranges

Diagram 8

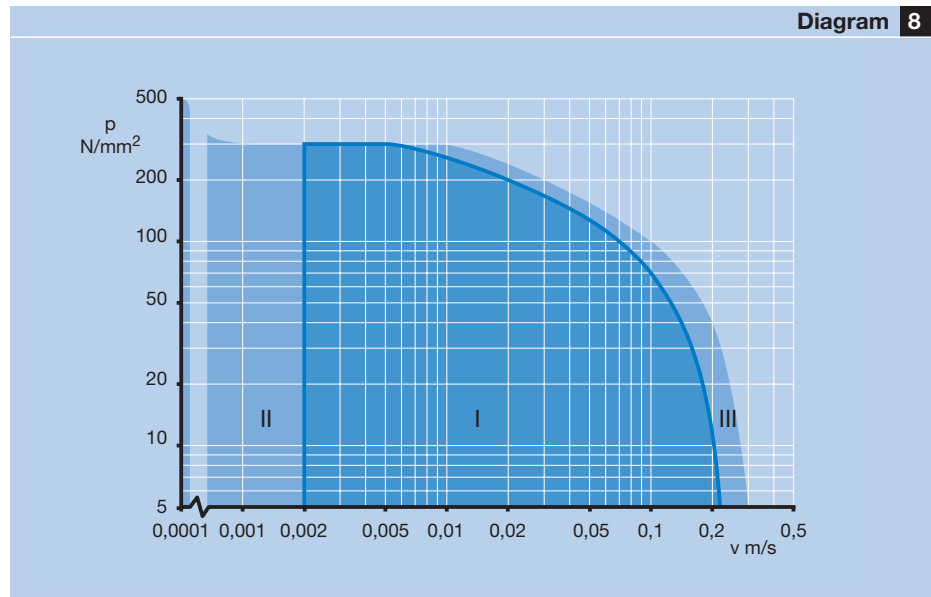

2

pv diagram for sliding contact surface combination steel/PTFE composite, FS and FSA designs
See Note 2 for explanation of operating ranges

Diagram 9

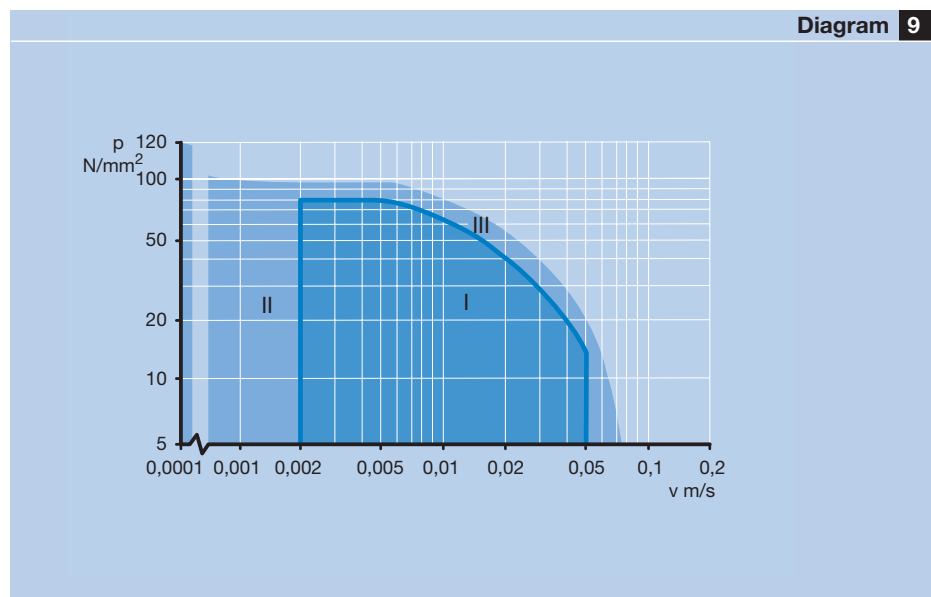

pv diagram for sliding contact surface combination steel/PTFE composite, F design
See Note 2 for explanation of operating ranges

Diagram 10

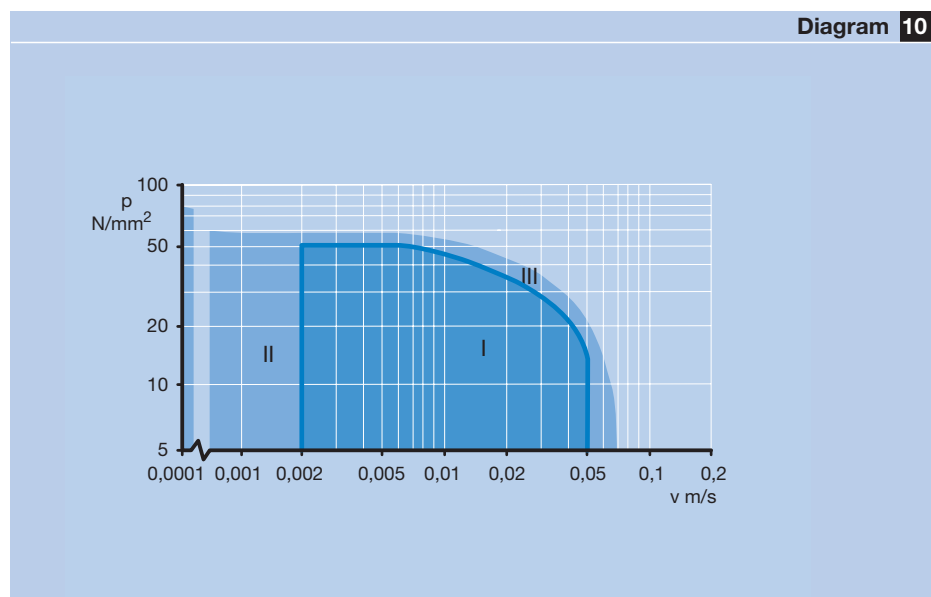

Note 2

pv operating ranges

- I Range where rating life equation is valid
- II Quasi-static range; rating life equation has limited validity, see under **“Basic rating life”** starting on page 24
- III Possible range of use, e.g. with very good heat removal; before using the rating life equation, please contact SKF

Temperature factor b_2

Table 5

Operating temperature over incl.		Temperature factor b_2
°C		–
–	120	1,0
120	160	0,9
160	180	0,8
180	–	Please contact SKF

The following temperature limits must also be respected
 80 °C For bearings of series GEZ .. ES-2RS (polyurethane seals)
 130 °C For all other sealed bearings (polyester elastomer seals)
 120 °C Upper temperature limit for standard grease

Sliding factor b_3

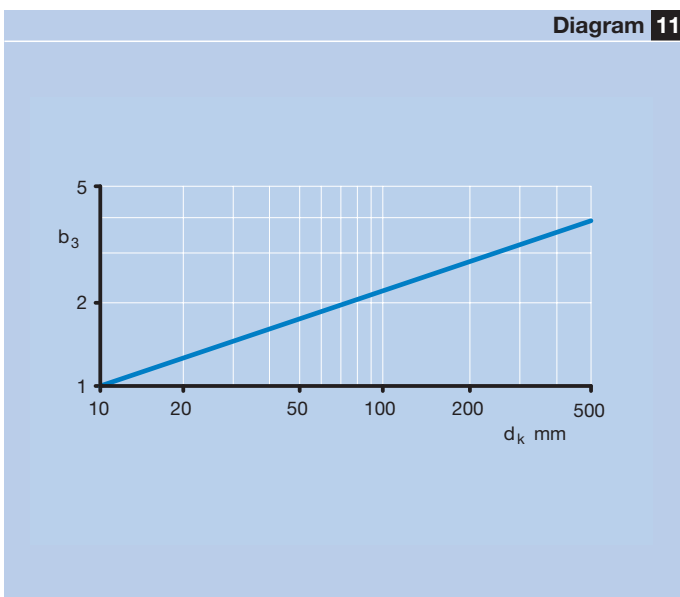

Velocity factor b_4

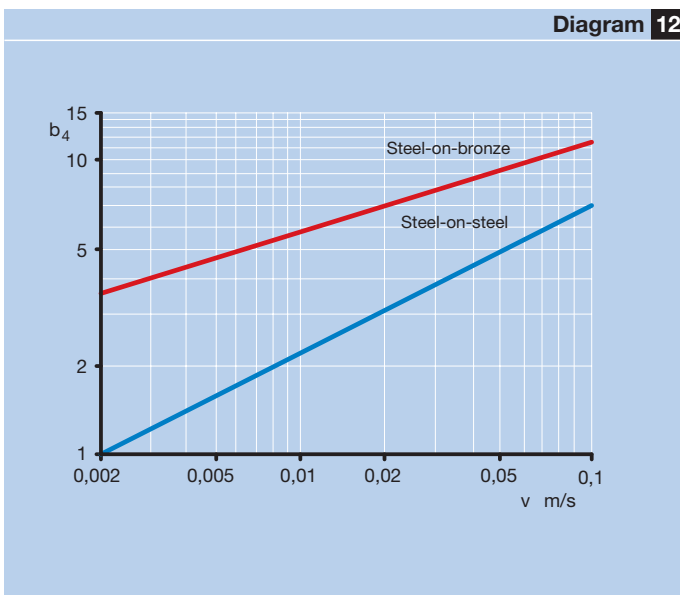

Basic rating life

Sliding contact surface combinations requiring maintenance: steel-on-steel and steel-on-bronze

For the initial lubrication

$$G_h = b_1 b_2 b_3 b_4 b_5 \frac{330}{p^{2,5} v}$$

and when the product is regularly relubricated thereafter

$$G_{hN} = G_h f_\beta f_H$$

or

$$G_N = 60 f G_{hN}$$

where

G_h = rating life for the initial lubrication, operating hours

G_{hN} = basic rating life with regular relubrication, operating hours

G_N = basic rating life with regular relubrication, number of oscillations

b_1 = load direction factor,
 $b_1 = 1$ for constant direction load

$b_1 = 2$ for alternating direction load

b_2 = temperature factor (→ Table 5)

b_3 = sliding factor (→ Diagram 11)

b_4 = velocity factor (→ Diagram 12)

b_5 = factor for angle of oscillation (→ Diagram 13), see also under “NB.”

f = frequency of oscillation, min^{-1}

f_β = factor depending on the angle of oscillation (→ Diagram 14), see also under “NB.”

f_H = factor depending on frequency of relubrication (→ Diagram 15)

p = specific bearing load, N/mm^2
 (for values of $p < 10 \text{ N/mm}^2$ use $p = 10 \text{ N/mm}^2$)

v = mean sliding velocity, m/s

If the basic rating life requirement is not met, then the relubrication interval N (→ Diagram 15) should be shortened, or a larger bearing or rod end should be chosen.

Diagram 13

Angle of oscillation factor b_5

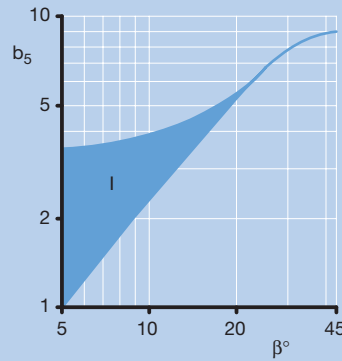

If $\beta < 5^\circ$, the value of b_5 for $\beta = 5^\circ$ should be used

Diagram 14

Multiplication factor f_β

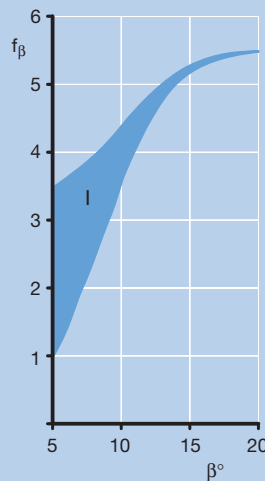

If $\beta < 5^\circ$, half the value of f_β for $\beta = 5^\circ$ should be used

Diagram 15

Relubrication factor f_H

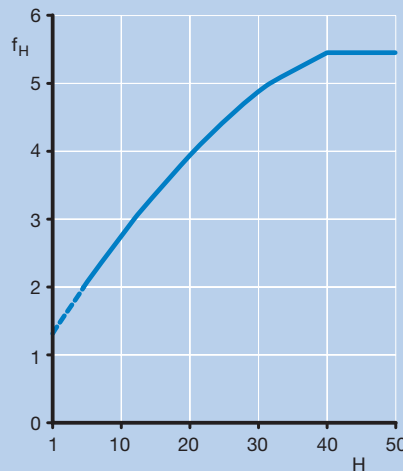

The frequency of relubrication H is defined as the ratio of the basic rating life G_H to the relubrication interval N (in h), i.e. $H = G_H/N$; if $H < 5$, the values indicated by the broken line can be used

NB.

SKF steel-on-steel spherical plain bearings having an outside diameter of 150 mm and above are produced as standard with the multi-groove feature in the outer ring (→ page 6). The extra large grease reservoir in the bearing made possible by the multi-groove system is advantageous, particularly where the load is of constant direction, and enables the relubrication interval to be extended, and also the service life.

These advantages are considered in the calculation of the basic rating life by the coloured regions in Diagrams 13 and 14 for the factors for the angle of oscillation b_5 and f_β . Values of these two factors up to the upper limit of the coloured area may be used for bearings with the multi-groove system.

Load direction factor b_1 for sliding contact surface combination steel/sinter bronze composite

Table 6		
Type of load	Factor b_1	Permissible specific bearing load ¹⁾
–	–	N/mm ²
Constant load²⁾		
Single direction	1	–
Variable load		
Alternating direction or pulsating magnitude at a frequency up 0,5 Hz	0,4	40 to 60
over 0,5 up to 5 Hz	0,2	25 to 40

¹⁾ Inertia forces should also be taken into consideration
²⁾ For constant load, oscillating frequencies above 300 min⁻¹ and very short sliding distances, $b_1 = 1$ can no longer be used because of possible material fatigue; please contact SKF for guidance

Temperature factor b_2 for sliding contact surface combination steel/sinter bronze composite

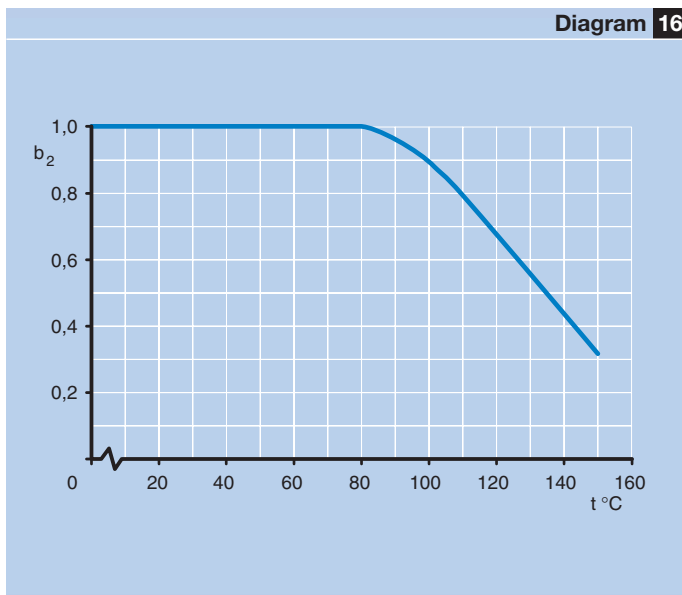

Maintenance-free sliding contact surface combination steel/sinter bronze composite

$$G_h = b_1 b_2 \frac{1\,400}{p^{1,3} v}$$

or

$$G = 60 f G_h$$

where

G = basic rating life, number of oscillations

G_h = basic rating life, operating hours

b_1 = load direction factor

(→ Table 6)

b_2 = temperature factor (→ Diagram 16)

f = frequency of oscillation, min⁻¹

p = specific bearing load, N/mm²

v = mean sliding velocity, m/s

NB.

Calculation of the rating life considers the influence of the load and sliding velocity. Under very light loads and/or low sliding velocities, the equations will give relatively long service lives. However, the influence of environmental factors such as contamination, damp or moisture and corrosion increases in importance the longer the life so that deviations from the calculated life occur and in many cases the calculated life will not be attained.

Maintenance-free sliding contact surface combination steel/PTFE fabric

$$G_h = b_1 b_2 b_4 \frac{K_p}{p^n v}$$

where

G_h = basic rating life, operating hours

b_1 = load direction factor

(→ **Table 7**)

b_2 = temperature factor

(→ **Diagram 17**)

b_4 = velocity factor

(→ **Diagram 18**, page 28)

p = specific bearing load, N/mm²

K_p = a constant for the specific bearing load (→ **Table 8**)

n = an exponent for the specific bearing load (→ **Table 8**)

v = mean sliding velocity, m/s

Table 7

Type of load	Specific load	factor b_1
–	N/mm ²	–
Constant, single direction	up to 300	1
Varying loads (alternating, pulsating) at load frequencies up to 0,5 Hz	up to 50 50 to 100	0,55 0,4
over 0,5 to 1 Hz	up to 50 50 to 100	0,35 0,15
over 1 to 5 Hz	up to 50	0,1

Load direction factor b_1 for sliding contact surface combination steel/PTFE fabric



Diagram 17

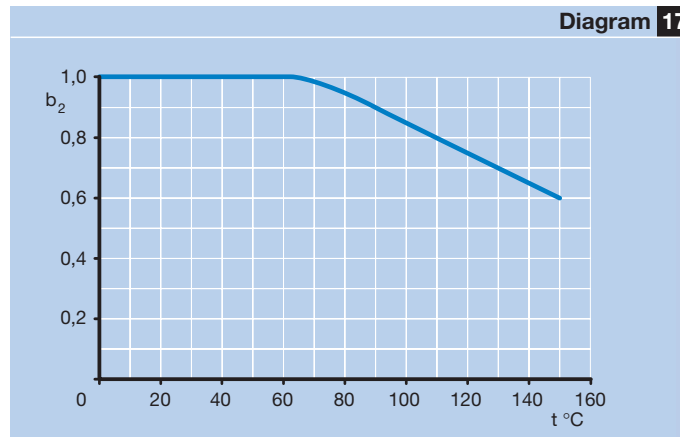

Temperature factor b_2 for sliding contact surface combination steel/PTFE fabric

Table 8

Specific bearing load	Constant K_p	Exponent n
over incl.	–	–
N/mm ² –	–	–
25	770	0,2
25 90	4 000	0,7
90 300	40 000	1,2

Constant K_p and exponent n for sliding contact surface combination steel/PTFE fabric

NB.

Calculation of the rating life considers the influence of the load and sliding velocity. Under very light loads and/or low sliding velocities, the equations will give relatively long service lives. However, the influence of environmental factors such as contamination, damp or moisture and corrosion increases in importance the longer the life so that deviations from the calculated life occur and in many cases the calculated life will not be attained.

Velocity factor b_4

Diagram 18

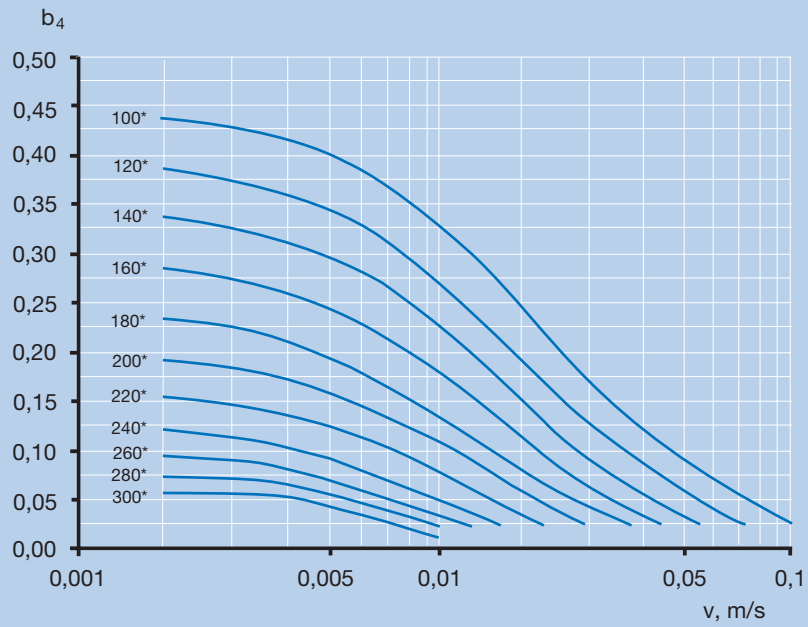
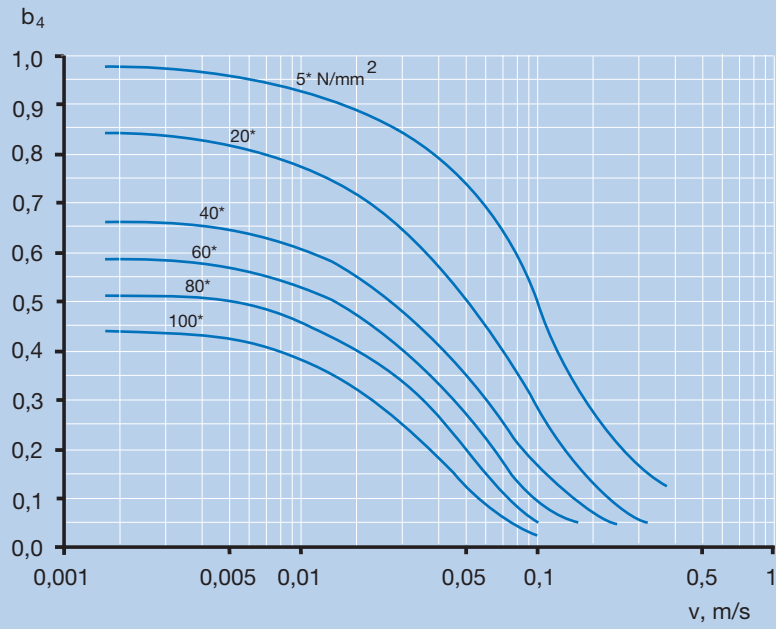

*) Specific bearing load

Maintenance-free sliding contact surface combination steel/PTFE composite

$$G_h = b_1 b_2 b_3 \frac{K_M}{pv}$$

or

$$G = 60 f G_h$$

where

G = basic rating life, number of oscillations

G_h = basic rating life, operating hours

b₁ = load direction factor (→ Table 9)

b₂ = temperature factor (→ Diagram 19)

b₃ = sliding factor (→ Table 10)

K_M = material constant (→ Table 10)

f = frequency of oscillation, min⁻¹

p = specific bearing load, N/mm²

v = mean sliding velocity, m/s

Table 9

Type of load	Factor b ₁	Permissible specific bearing load ¹⁾
–	–	N/mm ²
Constant load²⁾ Single direction	1	–
Variable load Alternating direction or pulsating magnitude at a frequency up to 0,5 Hz over 0,5 up to 5 Hz	0,25 0,1	25 to 40 15 to 25

¹⁾ Inertia forces should also be taken into consideration.
²⁾ For constant load, oscillating frequencies above 300 min⁻¹ and very short sliding distances, b₁ = 1 can no longer be used because of possible material fatigue; please contact SKF for guidance

Load direction factor b₁ for sliding contact surface combination steel/PTFE composite

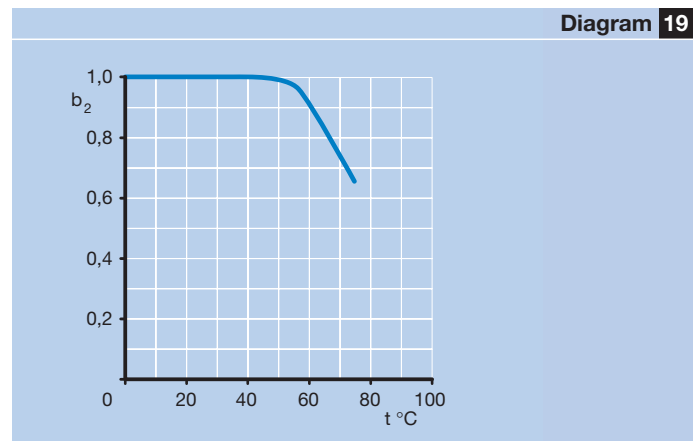

Temperature factor b₂ for sliding contact surface combination steel/PTFE composite

NB.

1. The basic rating life calculated using the above equation can be doubled by initial lubrication together with occasional relubrication, see under “Lubrication and maintenance”.
2. Calculation of the rating life considers the influence of the load and sliding velocity. Under very light loads and/or low sliding velocities, the equations will give relatively long service lives. However, the influence of environmental factors such as contamination, damp or moisture and corrosion increases in importance the longer the life so that deviations from the calculated life occur and in many cases the calculated life will not be attained.

Table 10

Bearing type Series	Bore diameter d Nominal over incl.	Sliding factor b ₃	Constant K _M
–	mm	–	–
Radial bearings			
GEP .. FS	– 180 440	1 1,15	1 055 1 055
GEC .. FSA	– 440	1 1,15	1 055 1 055
Angular contact bearings¹⁾			
GAC .. F	– 60	1 1,5	480 480
Thrust bearings			
GX .. F	– 60	1 1,5	670 670
Rod ends			
		1	530

¹⁾ For preloaded bearings which cannot be re-adjusted, b₃ always = 1

Sliding factor b₃ and constant K_M for sliding contact surface combination steel/PTFE composite

Variable load and sliding velocity

If, during operation, the load and/or the sliding velocity change it is first necessary to calculate individual rating lives for the periods of constant load and sliding velocity, before the basic rating life can be calculated. If the load and sliding velocity occur as shown by (a) in **fig 12** the individual basic rating life can be calculated using the constant values of p and v . However, when the load and sliding velocity are not constant (b) in **fig 12**, it is first necessary to calculate the basic rating life for the individual time periods using mean values of the load and the sliding velocity for the individual time periods. When this has been done, the total basic rating life can be calculated using the following equation

**Basic rating life
Calculation examples**

$$G_h = \frac{1}{\frac{t_1}{T G_{h1}} + \frac{t_2}{T G_{h2}} + \frac{t_3}{T G_{h3}} + \dots}$$

where

- G_h = total basic rating life, operating hours
- $t_1, t_2 \dots$ = time during which p_1 and v_1, p_2 and v_2 etc. pertain, h
- T = total duration of one cycle (= $t_1 + t_2 + t_3 + \dots$), h
- $G_{h1} \dots$ = individual values of rating life for conditions p_1 and v_1, p_2 and v_2 etc., operating hours

Calculation examples

The calculation examples shown in the following serve to illustrate the methods used to calculate the requisite bearing size or the basic rating life for spherical plain bearings and rod ends.

Using the SKF Interactive Engineering Catalogue which incorporates programs to do these and many other calculations, results will be obtained quickly and accurately. Additionally, the programs can be run any number of times to enable the best possible solution to be obtained.

The SKF Interactive Engineering Catalogue is available on CD-ROM or online at www.skf.com.

Alternating load and variable sliding velocity

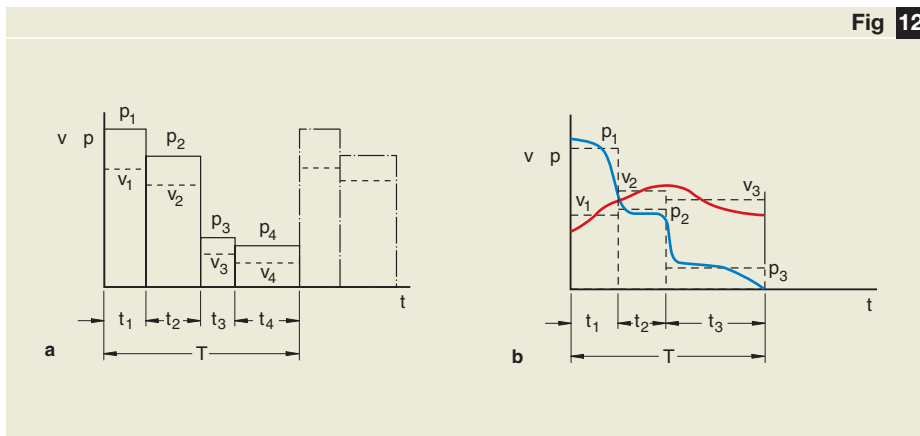

Fig 12

Example 1

The torque support of a concrete transporter

Given:

Purely radial load (alternating direction): $F_r = 12 \text{ kN}$

Half angle of oscillation: $\beta = 15^\circ$

(→ fig 3, page 16)

Frequency of oscillation: $f = 10 \text{ min}^{-1}$

maximum operating temperature: $+80 \text{ }^\circ\text{C}$

Requirement:

A bearing which has a basic rating life of 7 000 h.

As the load is alternating, a steel-on-steel spherical plain bearing is the appropriate choice. The intention is to relubricate the bearing after each 40 hours of operation.

If, for the first check, a guideline value of 2 is used for the load ratio C/P (→ Table 3, page 21), the required basic dynamic load rating C for the bearing is

$$C = 2 P = 24 \text{ kN}$$

Bearing GE 20 ES having $C = 30 \text{ kN}$ and a sphere diameter $d_k = 29 \text{ mm}$ is chosen from the product table, page 62.

To be able to check the suitability of the bearing using the **pv diagram 5**, page 22, it is first necessary to calculate the specific bearing load using $K = 100$ from Table 4, page 21

$$p = K \frac{P}{C} = 100 \times \frac{12}{30} = 40 \text{ N/mm}^2$$

and the sliding velocity v using $d_m = d_k = 29 \text{ mm}$, $\beta = 15^\circ$ and $f = 10 \text{ min}^{-1}$

$$\begin{aligned} v &= 5,82 \times 10^{-7} d_m \beta f \\ &= 5,82 \times 10^{-7} \times 29 \times 15 \times 10 \\ &= 0,0025 \text{ m/s} \end{aligned}$$

These values for p and v lie within the permissible operating range I of the **pv diagram 5**, page 22, for steel-on-steel spherical plain bearings. To calculate the basic rating life for initial lubrication, the values that apply are



$$\begin{aligned} b_1 &= 2 \text{ (alternating direction load)} \\ b_2 &= 1 \text{ (operating temperature } < 120 \text{ }^\circ\text{C} \text{ from Table 5, page 24)} \\ b_3 &= 1,5 \text{ (from Diagram 11, page 24, for } d_k = 29 \text{ mm)} \\ b_4 &= 1,1 \text{ (from Diagram 12, page 24, for } v = 0,0025 \text{ m/s)} \\ b_5 &= 3,7 \text{ (from Diagram 13, page 25, for } \beta = 15^\circ) \\ p &= 40 \text{ N/mm}^2 \\ v &= 0,0025 \text{ m/s} \end{aligned}$$

Therefore

$$\begin{aligned} G_h &= b_1 b_2 b_3 b_4 b_5 \frac{330}{p^{2,5} v} \\ &= 2 \times 1 \times 1,5 \times 1,1 \times 3,7 \times \frac{330}{40^{2,5} \times 0,0025} \\ &\approx 160 \text{ operating hours} \end{aligned}$$

The basic rating life of the bearing which is to be relubricated regularly can now be calculated using

$$\begin{aligned} f_\beta &= 5,2 \text{ (from Diagram 14, page 25)} \\ f_H &= 1,8 \text{ (from Diagram 15, page 25, for a relubrication frequency } H = G_h/N = 160/40 = 4 \text{ with the relubrication interval of 40 h)} \end{aligned}$$

$$\begin{aligned} G_{hN} &= G_h f_\beta f_H = 160 \times 5,2 \times 1,8 \\ &\approx 1\,500 \text{ operating hours} \end{aligned}$$

As this life is shorter than the required rating life of 7 000 h, a larger bearing must be chosen and the calculations repeated.

Bearing GE 25 ES having $C = 48 \text{ kN}$ and $d_k = 35,5 \text{ mm}$ is chosen. The values for the specific bearing load

$$p = 100 \times \frac{12}{48} = 25 \text{ N/mm}^2$$

and the sliding velocity

$$\begin{aligned} v &= 5,82 \times 10^{-7} \times 35,5 \times 15 \times 10 \\ &= 0,0031 \text{ m/s} \end{aligned}$$

lie within the permissible operating range I of the **pv diagram 6**, page 22. As before

$$b_1 = 2, b_2 = 1, b_5 = 3,7$$

and now

$$\begin{aligned} b_3 &= 1,6 \text{ (from Diagram 11, page 24, for } d_k = 35,5 \text{ mm)} \\ b_4 &= 1,3 \text{ (from Diagram 12, page 24, for } v = 0,0031 \text{ m/s)} \end{aligned}$$

Therefore, the basic rating life for initial lubrication

$$\begin{aligned} G_h &= 2 \times 1 \times 1,6 \times 1,3 \times 3,7 \times \frac{330}{25^{2,5} \times 0,0031} \\ &\approx 520 \text{ h} \end{aligned}$$

With $f_\beta = 5,2$ (from Diagram 14, page 25) and $f_H = 3,1$ (from Diagram 15, page 25 for $H = 520/40 = 13$) the basic rating life for regular relubrication ($N = 40 \text{ h}$) becomes

$$\begin{aligned} G_{hN} &= 520 \times 5,2 \times 3,1 \\ &\approx 8\,300 \text{ operating hours} \end{aligned}$$

This larger bearing thus satisfies the rating life requirement.

Example 2

The attachment of a shock absorber of an off-highway vehicle

Given:

Radial load: $F_r = 7 \text{ kN}$

Axial load: $F_a = 0,7 \text{ kN}$

Half angle of oscillation: $\beta = 8^\circ$

(fig 3, page 16)

Frequency of oscillation: $f = 15 \text{ min}^{-1}$

Load frequency: 2–5 Hz

Maximum operating temperature: $+75 \text{ }^\circ\text{C}$

Required:

A bearing which will have a basic rating life corresponding to a driven distance of 100 000 km at an average speed of 65 km/h without maintenance.

For design reasons, spherical plain bearing GE 20 C with the sliding contact surface combination steel/sinter bronze composite is proposed. From the bearing table, page 76, the basic dynamic load rating $C = 31,5 \text{ kN}$ and the sphere diameter $d_k = 29 \text{ mm}$.

First the equivalent dynamic bearing load must be determined

$$F_a/F_r = 0,7/7 = 0,1$$

which gives factor $y = 1,4$ from Diagram 2, page 19. The equivalent dynamic bearing load is thus

$$P = y F_r = 1,4 \times 7 = 9,8 \text{ kN}$$

A first check of bearing size using the pv diagram 7, page 22, shows that the values for the specific bearing load ($K = 100$ from Table 4, page 21)

$$p = K \frac{P}{C} = 100 \times \frac{9,8}{31,5} = 31 \text{ N/mm}^2$$

and the sliding velocity ($d_m = d_k = 29 \text{ mm}$)

$$\begin{aligned} v &= 5,82 \times 10^{-7} d_m \beta f \\ &= 5,82 \times 10^{-7} \times 29 \times 8 \times 15 \\ &= 0,002 \text{ m/s} \end{aligned}$$

so that this lies in the permissible operating range I of the pv diagram. Using



$b_1 = 0,2$ (from Table 6, page 26, for a load frequency over 0,5 Hz and $25 < p < 40 \text{ N/mm}^2$)

$b_2 = 1$ (from Diagram 16, page 26, for temperatures $< 80 \text{ }^\circ\text{C}$)

the basic rating life for bearing GE 20 C with the sliding contact surface combination steel/sinter bronze composite is

$$\begin{aligned} G_h &= b_1 b_2 \frac{1\,400}{p^{1,3} v} \\ &= 0,2 \times 1 \times \frac{1\,400}{31^{1,3} \times 0,002} \\ &\approx 1\,600 \text{ h} \end{aligned}$$

This basic rating life corresponds to a distance (at an average speed of 65 km/h) of $1\,600 \times 65 = 104\,000 \text{ km}$.

Example 3

The 320-bar hydraulic cylinder of a fully automatic press for building industry waste

Given:

Radial load (constant direction):

Operation case	Load, F_r	Time period, t
I	300 kN	10 %
II	180 kN	40 %
III	120 kN	50 %

The number of press cycles $n = 30$ per hour, and the movement between the end positions (90°) is made in 10 seconds. The operating temperature is less than $+50 \text{ }^\circ\text{C}$.

Required:

A maintenance-free spherical plain bearing with the sliding contact surface combination steel/PTFE fabric for a rating life of 5 years for 70 h of operation per week.

Using a guideline value for the load ratio $C/P = 2$ (\rightarrow Table 3, page 21), and with $P = F_{rI}$ the required basic dynamic load rating

$$C = 2 P = 2 \times 300 = 600 \text{ kN}$$

From the product table, page 78, bearing GE 60 TXE-2LS has a basic dynamic load rating $C = 695 \text{ kN}$ and a sphere diameter $d_k = d_m = 80 \text{ mm}$ is chosen (\rightarrow page 21).

First it is necessary to check that the operation cases I to III fall within the permissible range of the pv diagram 8, page 23.

The sliding velocity is the same for all three cases. The angle of oscillation is specified as 2β , the time t as the time taken to pass through 2β in seconds. Complete cycle duration is 4β (\rightarrow pages 16 and 21).

$$\begin{aligned} v &= 8,73 \times 10^{-6} \times d_m \frac{2\beta}{t} \\ &= 8,73 \times 10^{-6} \times 80 \times \frac{90}{10} \\ &= 0,0063 \text{ m/s} \end{aligned}$$



The specific bearing load, $p = K(P/C)$, using $K = 300$ from **Table 4, page 21**, is

for case I

$$p_I = K \frac{P}{C} = 300 \times \frac{300}{695} \approx 129,5 \text{ N/mm}^2$$

for case II

$$p_{II} = K \frac{P}{C} = 300 \times \frac{180}{695} \approx 77,7 \text{ N/mm}^2$$

for case III

$$p_{III} = K \frac{P}{C} = 300 \times \frac{120}{695} \approx 51,8 \text{ N/mm}^2$$

The values for p_I , p_{II} , p_{III} and v are within the permissible range I of the **pv diagram 8, page 23**.

To make the lifetime estimation for variable loads and/or sliding velocities the calculation of each load case has to be made separately, with the equation for TX bearings first:

$$G_h = b_1 b_2 b_4 \frac{k_p}{p^n v}$$

The parameters b_1 , b_2 , b_4 , k_p and n are defined on **page 27** and are as below

$b_1 = 1$ (from **Table 7, page 27**, constant load)

$b_2 = 1$ (from **Diagram 17, page 27**, operating temperature $< +50 \text{ }^\circ\text{C}$)

$b_4 =$ (from **Diagram 18, page 28**)

$$b_{4I} = 0,31$$

$$b_{4II} = 0,48$$

$$b_{4III} = 0,57$$

$K_p =$ (from **Table 8, page 27**)

$$K_{pI} = 40\,000$$

$$K_{pII} = 4\,000$$

$$K_{pIII} = 4\,000$$

$n =$ (from **Table 8, page 27**)

$$n_1 = 1,2$$

$$n_2 = 0,7$$

$$n_3 = 0,7$$

for case I

$$G_{hI} = 1 \times 1 \times 0,31 \times \frac{40\,000}{129,5^{1,2} \times 0,0063}$$

$$\approx 5\,746 \text{ h}$$

for case II

$$G_{hII} = 1 \times 1 \times 0,48 \times \frac{4\,000}{77,7^{0,7} \times 0,0063}$$

$$\approx 14\,477 \text{ h}$$

for case III

$$G_{hIII} = 1 \times 1 \times 0,57 \times \frac{4\,000}{51,8^{0,7} \times 0,0063}$$

$$\approx 22\,833 \text{ h}$$

Using the calculated basic rating lives of the three operation cases, the total basic rating life for continuous operation is (\rightarrow **page 30**)

$$G_h = \frac{1}{\frac{t_I}{T G_{hI}} + \frac{t_{II}}{T G_{hII}} + \frac{t_{III}}{T G_{hIII}}}$$

For t_I , t_{II} etc. the percentages given in the operating data are inserted and for $T = t_I + t_{II} + t_{III} = 100 \text{ } \%$.

$$G_h = \frac{1}{\frac{10}{100 \times 5\,746} + \frac{40}{100 \times 14\,477} + \frac{50}{100 \times 22\,833}}$$

$$\approx 14\,940 \text{ h}$$

The required 5 years of rating life leads with the mentioned 70 h/week, 30 cycles/hour and assumed 50 weeks per year, to 525 000 cycles or 2 920 h. (Note that time for a complete cycle is 20 s.)

$$G_{N, \text{Req}} = 5 \times 70 \times 30 \times 50$$

$$= 525\,000 \text{ cycles}$$

$$G_{h, \text{Req}} = (525\,000 \times 20) / 3\,600$$

$$= 2\,916 \text{ h}$$

Example 4

The linkages of a conveyor installation

Given:

Radial load of alternating direction:

$$F_r = 5,5 \text{ kN}$$

Half angle of oscillation: $\beta = 15^\circ$

(→ fig 3, page 16)

Frequency of oscillation: $f = 25 \text{ min}^{-1}$

Operating temperature: $\approx +70^\circ \text{C}$

Required:

A rod end that will provide a basic rating life of 9 000 hours under conditions of alternating load.

As the load is alternating, a steel-on-steel rod end is appropriate, and it is to be relubricated after every 40 hours of operation. Using the guideline value for the load ratio $C/P = 2$ from Table 3, page 21, and as $P = F_r$, the requisite basic dynamic load rating will be

$$C = 2 P = 2 \times 5,5 = 11 \text{ kN.}$$

The rod end SI 15 ES with a basic dynamic load rating $C = 17 \text{ kN}$ is selected (page 100). The basic static load rating $C_0 = 37,5 \text{ kN}$ and the sphere diameter $d_k = 22 \text{ mm}$.

The first check of size is made using the **pv diagram 5, page 22**, and with $K = 100$ (from Table 4, page 21)

$$p = K \frac{P}{C} = 100 \times \frac{5,5}{17} = 32 \text{ N/mm}^2$$

and the mean sliding velocity ($d_m = d_k = 22 \text{ mm}$)

$$v = 5,82 \times 10^{-7} d_k \beta f$$

$$= 5,82 \times 10^{-7} \times 22 \times 15 \times 25$$

$$= 0,0048 \text{ m/s}$$

p and v both lie within the permissible range I of the **pv diagram 5, page 22**.

Checking the permissible load on the rod end housing

$$C_0 = 37,5 \text{ kN}$$

$b_2 = 1$ (from Table 5, page 24, for temperatures $< 120^\circ \text{C}$)

$b_6 = 0,35$ (from Table 2, page 20, for rod ends with lubrication hole)



$$P_{\text{perm}} = C_0 b_2 b_6$$

$$= 37,5 \times 1 \times 0,35$$

$$= 13,125 \text{ kN} > P$$

The following values of the factors are used to determine the basic rating life for initial lubrication:

$b_1 = 2$ (alternating load)

$b_2 = 1$ (for operating temperatures

$< 120^\circ \text{C}$, from Table 5, page 24)

$b_3 = 1,3$ (from Diagram 11, page 24, for $d_k = 22 \text{ mm}$)

$b_4 = 1,6$ (from Diagram 12, page 24, for $v = 0,0048 \text{ m/s}$)

$b_5 = 3,7$ (from Diagram 13, page 25, for $\beta = 15^\circ$)

$$p = 32 \text{ N/mm}^2$$

$$v = 0,0048 \text{ m/s}$$

Therefore

$$G_H = b_1 b_2 b_3 b_4 b_5 \frac{330}{p^{2,5} v}$$

$$= 2 \times 1 \times 1,3 \times 1,6 \times 3,7 \times \frac{330}{32^{2,5} \times 0,0048}$$

$$\approx 180 \text{ operating hours}$$

The basic rating life for regular relubrication ($N = 40 \text{ h}$) with

$f_\beta = 5,2$ (from Diagram 14, page 25) and

$f_H = 2$ (from Diagram 15, page 25, for $H = G_H/N = 180/40 = 4,5$)

$$G_{HN} = G_H f_\beta f_H = 180 \times 5,2 \times 2$$

$$\approx 1\,900 \text{ operating hours}$$

The required basic rating life of 9 000 h is not achieved by the rod end, so that a larger one has to be used. Rod end SI 20 ES, with $C = 30 \text{ kN}$, $C_0 = 57 \text{ kN}$ and $d_k = 29 \text{ mm}$ is selected and the calculation repeated.

The values for the specific bearing load

$$p = 100 \times \frac{5,5}{30} \approx 18 \text{ N/mm}^2$$

and the mean sliding velocity ($d_m = d_k = 29 \text{ mm}$)

$$v = 5,82 \times 10^{-7} \times 29 \times 15 \times 25 = 0,0063 \text{ m/s}$$

both lie within the permissible range I. It is not necessary to check the permissible rod end housing load since the basic static load rating of the larger rod end is higher. Also, as before

$b_1 = 2$, $b_2 = 1$ and $b_5 = 3,7$

whilst

$b_3 = 1,4$ (from Diagram 11, page 24, for $d_k = 29 \text{ mm}$)

$b_4 = 1,8$ (from Diagram 12, page 24, for $v = 0,0063 \text{ m/s}$)

so that

$$G_H = 2 \times 1 \times 1,4 \times 1,8 \times 3,7 \times \frac{330}{18^{2,5} \times 0,0063}$$

$$\approx 710 \text{ operating hours}$$

With $f_\beta = 5,2$ (from Diagram 14, page 25) and $f_H = 3,7$ (from Diagram 15, page 25, for $H = 710/40 \approx 18$) the basic rating life for regular relubrication ($N = 40 \text{ h}$) becomes

$$G_{HN} = 710 \times 5,2 \times 3,7$$

$$\approx 13\,600 \text{ operating hours}$$

Thus the larger rod end meets the rating life requirements.

Friction

The friction in a spherical plain bearing or rod end is primarily dependent on the sliding contact surface combination, the load and the sliding velocity. Because there are so many influencing factors which are not mutually independent it is not possible to quote exact values for the coefficient of friction. Under laboratory conditions, however, it is possible to record typical developments of the coefficient of friction for different sliding contact surface combinations. The friction during the running-in phase is higher than the value recorded during the subsequent test period. For example, for regularly relubricated steel-on-steel spherical plain bearings when a suitable highly viscous lubricant is used (e.g. the SKF grease LGHB 2). Guideline values for the coefficient of friction μ will be found in **Table 1**. They have been determined in laboratory trials.

The coefficient of friction for the maintenance-free sliding contact surface combinations steel/PTFE fabric and steel/sinter bronze composite decrease with increasing specific load. At a constant specific load, friction will

be reduced to the given minimum value as soon as the transfer of PTFE from the sliding layer to the opposing steel surface has been completed. The friction torque for a spherical plain bearing or rod end can be calculated using

$$M = 0,5 \times 10^{-6} \mu P d_m$$

where

M = friction torque, Nm

μ = coefficient of friction
(→ **Table 1**)

P = equivalent dynamic bearing load, kN

d_m = mean bearing diameter, mm, for radial spherical plain bearings
 $d_m = d_k$ for radial spherical plain bearings

$d_m = 0,9 d_k$ for angular contact spherical plain bearings

$d_m = 0,7 d_k$ for spherical plain thrust bearings

As operation progresses and as a result of negative influences (contamination, inadequate lubrication), even under very light loads, the maximum values of the coefficient of friction

quoted in the table may be approached or even exceeded if conditions are particularly unfavourable. In applications where friction is especially important, therefore, it is recommended that the maximum values of the coefficient of friction be used when determining the required power rating, for security reasons. For all bearings, which are operated under conditions of mixed or dry friction, there may be small differences between adhesive and sliding friction. Operation which is entirely free of stick-slip cannot be achieved. Experience has shown that stick-slip effects occur when the surrounding construction is "soft". In most applications, however, the effects are negligible.

Table 1

Sliding contact surface combination	Coefficient of friction μ	
	min	max
Steel-on-steel	0,08	0,20
Steel-on-bronze	0,10	0,25
Steel/sinter bronze composite	0,05	0,25
Steel/PTFE fabric	0,03	0,15
Steel/PTFE composite	0,05	0,20

Coefficients of friction for different sliding contact surface combinations (guideline values)

Application of bearings

Radial location of bearings

The inner and outer rings of spherical plain bearings must be radially secured (located) to the shaft and in the housing so that the sliding movements take place, as intended, in the bearing. Otherwise the rings may begin to creep or wander in or on their seatings in the circumferential direction under load.

Successful radial location is only usually achieved by using fits with sufficient interference. However, an interference fit cannot always be applied, e.g. if easy mounting and dismounting are desired, or if the bearing must be able to be displaced axially without restraint.

The appropriate fits are always determined by the operating conditions.

1. Type and magnitude of the load

The degree of interference must suit the type and magnitude of the load, i.e. the heavier the load, and the higher the shock content, the heavier the interference required (→ **fig 1**).

- Under heavy loads, spherical plain bearings will deform elastically which may lead to a loosening of the fit and creeping of the ring on/in its seating.
- The strength of the associated components must be adequate to take up the loads and fully support the bearing.
- If the associated components deform, there is a risk that hardened bearing rings will break.
- Steel-on-steel spherical plain bearings require tighter fits than the maintenance-free bearings which have lower friction.

2. Bearing internal clearance

An interference fit will cause the

- inner ring to expand elastically, and the
- outer ring to be compressed elastically.

This reduces the original internal clearance in the bearing to the so-called operating clearance (→ **fig 2**). The clearance also depends on load and temperature.

The original internal clearance differs depending on the type and size of the bearing and has been selected so that if the recommended tolerances for the shaft and housing seatings are applied, an appropriate operational clearance (or preload) will be left in the bearing under normal operating conditions.

If interference fits are used for both bearing rings, or if the temperature conditions are unusual, it may be necessary to use a larger initial internal clearance than “Normal” for steel-on-steel bearings.

Relationship between load and requisite interference

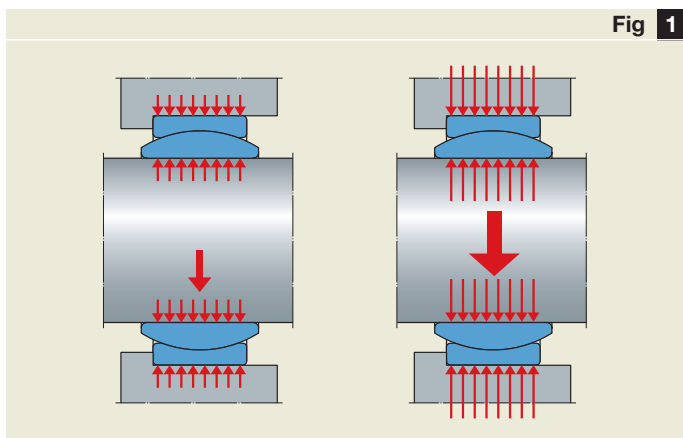

Fig 1

Operating clearance

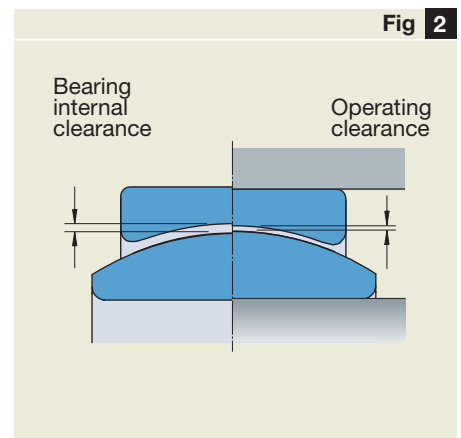

Fig 2

3. Temperature conditions

In operation, the bearing rings will normally have a higher temperature than their seatings. This means that

- the fit of the inner ring will loosen (→ **fig 3**) and
- the fit of the outer ring will become tighter, which may restrict any required axial displacement in the housing.

If there is a considerable temperature difference between inner and outer rings there will be a change in the operating clearance which must be considered when selecting the fits, so that a blockage of the bearing can be avoided.

4. Design of associated components

The design of the components providing the bearing seatings should not lead to irregular deformation (out-of-round) of the bearing (→ **fig 4**).

- Split housings are not suitable for interference fits.
- Thin-walled housings, light alloy housings and hollow shafts all call for a tighter fit to be used than for thick-walled steel or cast iron housings and solid shafts – and must have sufficient strength.
- Heavy loads and interference fits call for thick-walled one-piece steel or cast iron housings and solid steel shafts.

5. Axial displacement of non-locating bearings

A non-locating bearing, which is to provide radial support only, must always be able to be displaced axially (→ **fig 5**). This is normally achieved by selecting a loose fit for one of the bearing rings, generally the inner ring of spherical plain bearings. The reasons are

- the shaft seating can be easily and economically hardened and ground; this facilitates axial displacement. The hardness should be at least 50 HRC and the surface roughness R_z should be $\leq 10 \mu\text{m}$.
- the outer rings of most spherical plain bearings are axially fractured at one or two positions, or are radially split. This can hinder axial displacement or make it completely impossible.
- the housing bore should be protected against wear.

Surface finish of seatings

The recommended surface roughness to ISO 4288:1996 for the bearing seatings is

- for shaft seatings
 $R_z \leq 10 \mu\text{m}$
- for housing bore seatings
 $R_z \leq 16 \mu\text{m}$

Change of fit with temperature

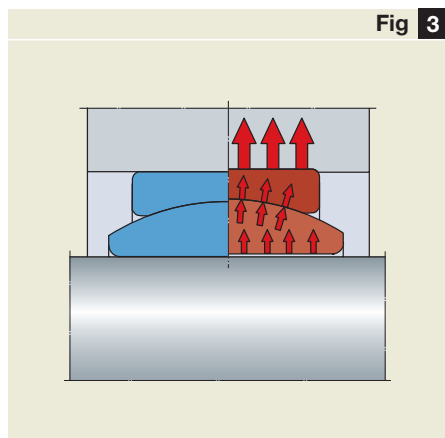

Out-of-round bearing seating

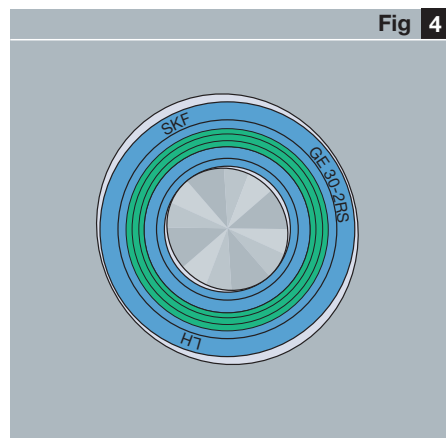

Axial displacement

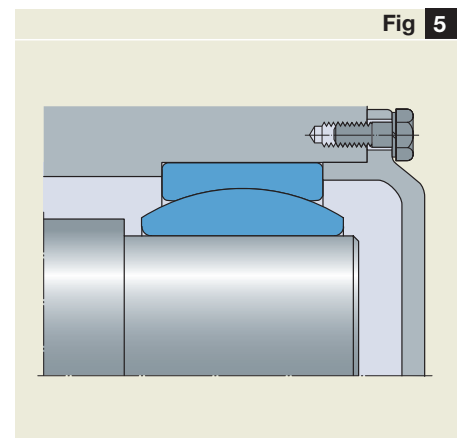

Table 1

Operating conditions	Tolerance Sliding contact surface combination steel-on-steel maintenance-free	
Radial bearings Loads of all kinds interference fit	m6 (n6) ¹⁾	k6
Loads of all kinds clearance or transition fit	h6 (hardened shaft)	h6 or g6 (hardened shaft)
Angular contact bearings Loads of all kinds interference fit	m6 (n6)	m6
Thrust bearings Loads of all kinds interference fit	m6 (n6)	m6

The tolerances given in brackets may be chosen for very heavily loaded bearings. If chosen, it is necessary to check that the residual operating clearance is sufficient for correct performance of the bearing or whether a bearing with larger clearance must be used

¹⁾ These recommendations do not apply to bearings of series GEG which have a bore diameter tolerance to H7 and are normally mounted on shaft seatings machined to m7. If, for mounting reasons the shaft is machined to tolerance f7, it should be hardened as relative movements of the shaft with respect to the bearing bore will take place and wear may result

Shaft fits

Housing fits

Table 2

Operating conditions	Tolerance Sliding contact surface combination steel-on-steel maintenance-free	
Radial bearings Light loads, axial displacement required	H7	H7
Heavy loads	M7 (N7)	K7
Light alloy housings	N7	M7
Angular contact bearings Loads of all kinds, interference fit	M7 (N7)	M7
Loads of all kinds, can generally be displaced axially	J7	J7
Thrust bearings Purely axial loads Combined loads	H11 J7	H11 J7

The tolerances given in brackets may be chosen for very heavily loaded bearings. If chosen, it is necessary to check that the residual operating clearance of radial bearings is sufficient for correct performance of the bearing or whether a bearing with larger clearance must be used

Recommended fits

Only a limited number of ISO tolerance grades are appropriate to spherical plain bearings. Fig 6 shows schematically the relative positions of these in relation to the bore and outside diameters of the bearings. The recommended tolerances for

- the shaft seatings are given in Table 1, and
- the housing bore in Table 2.

These recommendations are based on the considerations described above and have been confirmed in a wide variety of bearing applications. The ISO tolerance limits are given in

- Table 3 for shafts, and
- Table 4 for housing bores.

To facilitate the calculation of the minimum and maximum values of the theoretical interference or clearance, the standardized bearing bore diameter deviations (Δ_{dmp}) and the bearing outside diameter deviations (Δ_{Dmp}) are given in the tables.

ISO shaft and housing tolerances

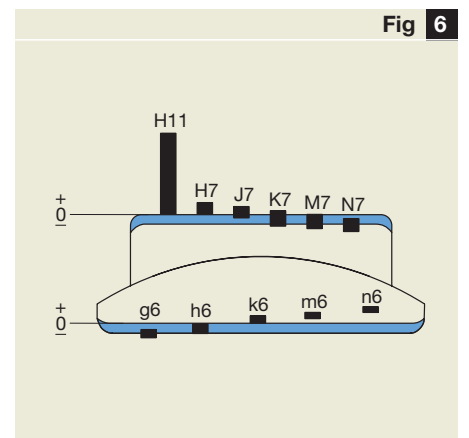

Table 3

Shaft Diameter		Bearing Bore diameter Δ_{Dmp}		Shaft diameter tolerances									
Nominal over	incl.	min	max	g6 Deviations		h6		k6		m6		n6	
				high	low	high	low	high	low	high	low	high	low
mm		μm		μm									
3	6	-8	0	-4	-12	0	-8	+9	+1	+12	+4	+16	+8
6	10	-8	0	-5	-14	0	-9	+10	+1	+15	+6	+19	+10
10	18	-8	0	-6	-17	0	-11	+12	+1	+18	+7	+23	+12
18	30	-10	0	-7	-20	0	-13	+15	+2	+21	+8	+28	+15
30	50	-12	0	-9	-25	0	-16	+18	+2	+25	+9	+33	+17
50	80	-15	0	-10	-29	0	-19	+21	+2	+30	+11	+39	+20
80	120	-20	0	-12	-34	0	-22	+25	+3	+35	+13	+45	+23
120	180	-25	0	-14	-39	0	-25	+28	+3	+40	+15	+52	+27
180	250	-30	0	-15	-44	0	-29	+33	+4	+46	+17	+60	+31
250	315	-35	0	-17	-49	0	-32	+36	+4	+52	+20	+66	+34
315	400	-40	0	-18	-54	0	-36	+40	+4	+57	+21	+73	+37
400	500	-45	0	-20	-60	0	-40	+45	+5	+63	+23	+80	+40
500	630	-50	0	-22	-66	0	-44	+44	0	+70	+26	+88	+44
630	800	-75	0	-24	-74	0	-50	+50	0	+80	+30	+100	+50
800	1 000	-100	0	-26	-82	0	-56	+56	0	+90	+34	+112	+56
1 000	1 250	-125	0	-28	-94	0	-66	+66	0	+106	+40	+132	+66

ISO shaft limits

ISO housing limits

Table 4

Housing Bore diameter		Bearing Outside diameter Δ_{Dmp}		Housing bore tolerances											
Nominal over	incl.	max	min	H11 Deviations		H7		J7		K7		M7		N7	
				low	high	low	high	low	high	low	high	low	high	low	high
mm		μm		μm											
10	18	0	-8	0	+110	0	+18	-8	+10	-12	+6	-18	0	-23	-5
18	30	0	-9	0	+130	0	+21	-9	+12	-15	+6	-21	0	-28	-7
30	50	0	-11	0	+160	0	+25	-11	+14	-18	+7	-25	0	-33	-8
50	80	0	-13	0	+190	0	+30	-12	+18	-21	+9	-30	0	-39	-9
80	120	0	-15	0	+220	0	+35	-13	+22	-25	+10	-35	0	-45	-10
120	150	0	-18	0	+250	0	+40	-14	+26	-28	+12	-40	0	-52	-12
150	180	0	-25	0	+250	0	+40	-14	+26	-28	+12	-40	0	-52	-12
180	250	0	-30	0	+290	0	+46	-16	+30	-33	+13	-46	0	-60	-14
250	315	0	-35	0	+320	0	+52	-16	+36	-36	+16	-52	0	-66	-14
315	400	0	-40	0	+360	0	+57	-18	+39	-40	+17	-57	0	-73	-16
400	500	0	-45	0	+400	0	+63	-20	+43	-45	+18	-63	0	-80	-17
500	630	0	-50	0	+440	0	+70	-	-	-70	0	-96	-26	-114	-44
630	800	0	-75	0	+500	0	+80	-	-	-80	0	-110	-30	-130	-50
800	1 000	0	-100	0	+560	0	+90	-	-	-90	0	-124	-34	-146	-56
1 000	1 250	0	-125	0	+660	0	+105	-	-	-105	0	-145	-40	-171	-66
1 250	1 600	0	-160	0	+780	0	+125	-	-	-125	0	-173	-48	-203	-78
1 600	2 000	0	-200	0	+920	0	+150	-	-	-150	0	-208	-58	-242	-92

Axial location of bearings

An interference fit is not sufficient to axially locate a bearing ring. Normally a suitable axial securement is required.

The bearing rings of a locating bearing should be axially located on both sides. The bearing rings generally have an interference fit and are usually supported on one side by a shaft or housing shoulder. Inner rings are axially secured on the side opposite the shoulder by

- a plate screwed to the shaft end (→ **fig 7**), or
- a spacer sleeve between the ring and a neighbouring machine component (→ **fig 8**).

Outer rings are generally retained by the cover of the housing bore (→ **fig 7**).

For non-locating bearings the outer ring (which normally has a tight fit) should be axially located; the inner ring must be free to move axially on the shaft (→ **fig 5**, page 37).

It should be observed that with bearings of series GEP (→ **fig 9**), which have a radially split outer ring, expansion forces will be produced under purely radial load; the axial components of these forces will act on the housing cover. The axial load acting on the cover may be as much as 30 % of the radial load. This must be taken into account when dimensioning the housing cover and selecting the size and number of the attachment screws.

If shaft and/or housing shoulders are undesirable because of manufacturing or assembly considerations, spacer sleeves or rings can be inserted between the bearing ring which is to be located and an adjacent machine component (→ **fig 10** and **11**).

The axial location of non-separable bearings using retaining rings (→ **fig 10** and **11**) saves space and permits quick mounting and dismantling, as well as simplifying the machining of seatings. If larger axial forces have to be accommodated, a support ring (→ **fig 11**) should be arranged between the bearing ring and the retaining ring, so that the retaining ring is not subjected to excessive bending moments.

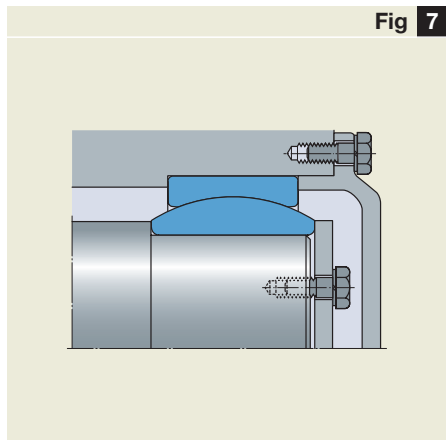

Using an end plate and cover to locate a bearing

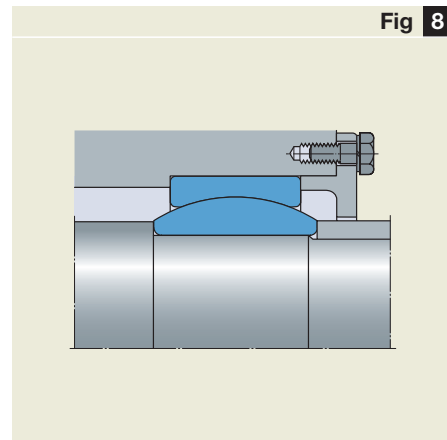

Using a spacer sleeve and cover to locate a bearing

For bearing location, the retaining rings used usually have constant radial width (also known as snap rings) to DIN 471:1981 or DIN 472:1981.

Locating a radially split bearing

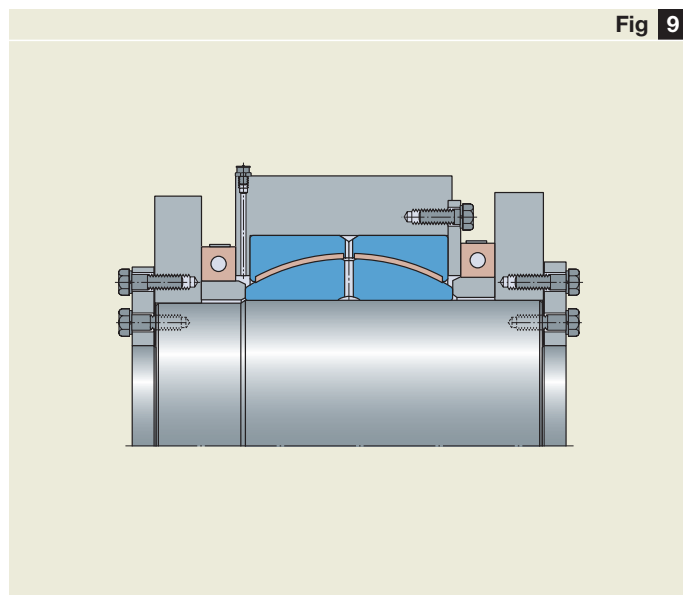

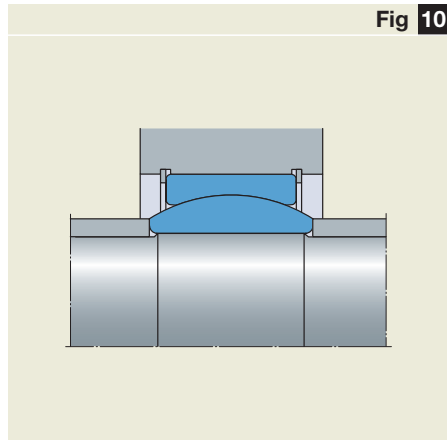

Locating a bearing using snap rings in the housing and adjacent components on the shaft

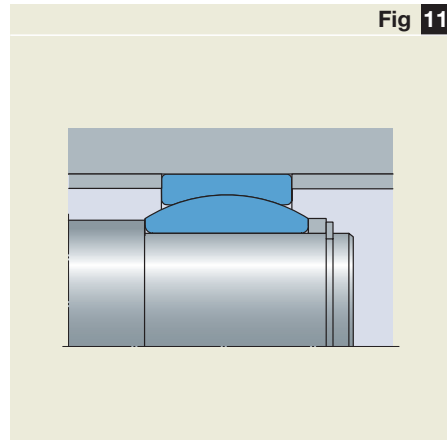

Locating a bearing using adjacent components in the housing and a retainer ring on the shaft

Abutment and fillet dimensions

The abutment and fillet dimensions should be such that

- a sufficiently large support surface is available for the bearing ring,
- moving parts of the bearing arrangement cannot foul stationary components, and
- the fillet radius should be smaller than the chamfer of the bearing.

Appropriate abutment dimensions (→ fig 12) are given for each bearing in the product tables. The transition from the bearing seating to the shaft or housing shoulder may be designed either as a fillet (→ fig 13) or an undercut (→ fig 14).

Recommended abutment and fillet dimensions

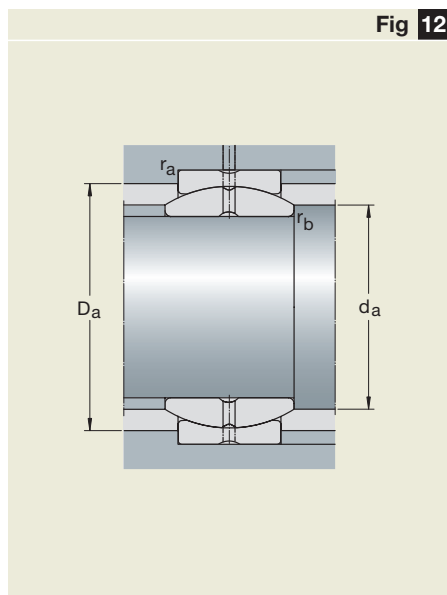

Fillet dimensions for shaft and housing shoulders

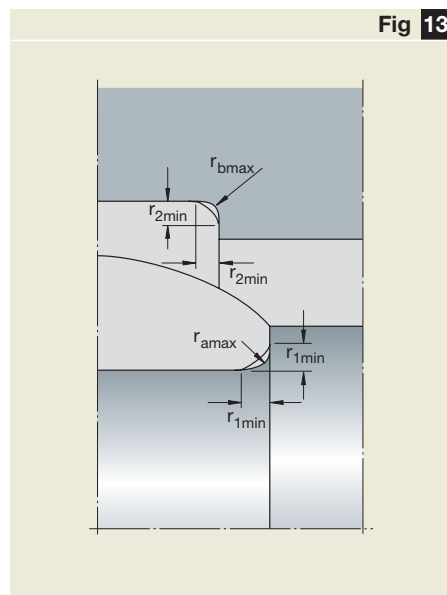

Undercut dimensions for shaft and housing shoulders

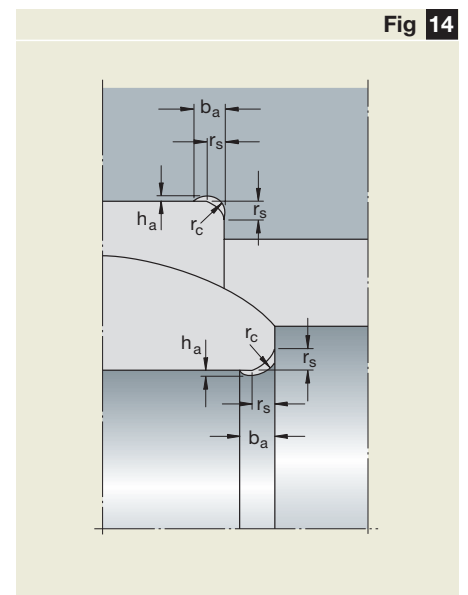

Fillet

Suitable dimensions for the fillet are given in the product tables and for the undercut in **Table 5**. The stress conditions in a stepped shaft are more favourable, the larger the fillet (rounding) of the transition to the shaft shoulder.

Rod ends

The inner rings of rod ends can, in the same way as bearings, be axially located by a shaft shoulder, a nut or a retaining ring.

Rod ends mounted on threaded rods or in extension tubes should be prevented from coming loose by an extra nut on the rod or the external thread of the rod end shank. The nut should be securely tightened against the support surface on the rod end housing or on the tube (→ **fig 15**).

Relieved fillets

Table 5

Chamfer dimensions r_1, r_2 min	Fillet dimensions		
	b_a	h_a	r_c
mm	mm		
1	2	0,2	1,3
1,1	2,4	0,3	1,5
1,5	3,2	0,4	2
2	4	0,5	2,5
2,5	4	0,5	2,5
3	4,7	0,5	3
4	5,9	0,5	4
5	7,4	0,6	5
6	8,6	0,6	6
7,5	10	0,6	7

Attachment of rod ends

Fig 15

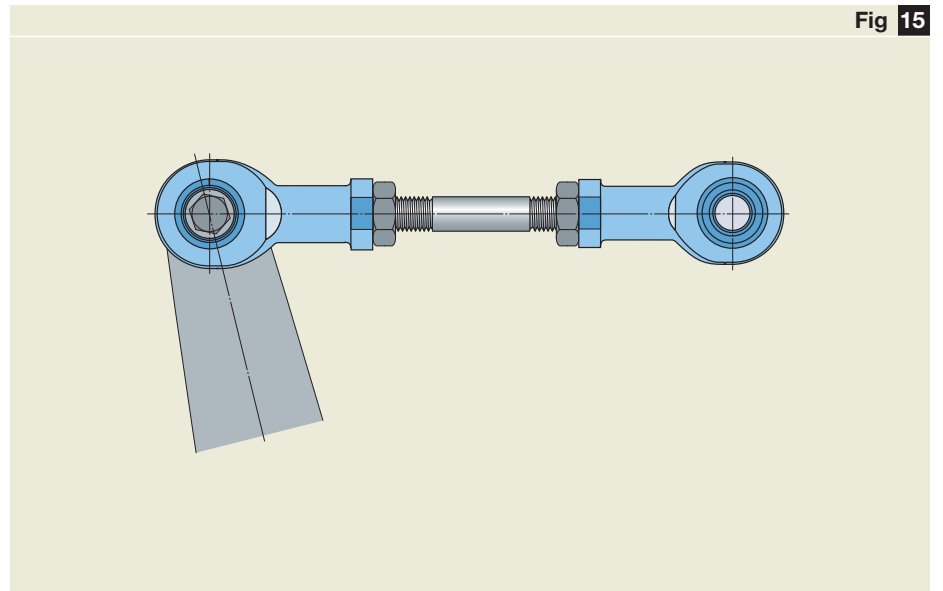

Sealing

Most bearing arrangements must be sealed to prevent external contamination and damp from entering the bearing. The efficiency of the sealing has a decisive influence of the service life of the bearing. In contrast to most other bearing types, which only move in one plane, the alignment capabilities of the spherical plain bearings place extra demands on the sealing.

When selecting appropriate seals, many factors have to be considered including

- the permissible angle of tilt,
- the available space,
- the environmental conditions,
- the efficiency of the seal,
- the type of lubrication and the frequency of relubrication, and
- the justifiable cost.

Depending on the application, one or other of the above factors will outweigh the others. It is therefore not possible to establish general rules for sealing design. **Table 6, pages 44 and 45**, gives an overview of the possible seals, their design characteristics and suitability to meet different demands.

Note

Further information about radial shaft seals, referred to in the table, can be found in the SKF catalogue 4006 “CR seals” or the “SKF Interactive Engineering Catalogue” on CD-ROM or online at www.skf.com.

Sealing strips can also be supplied by SKF in felt (FS strips) or, for high temperatures, in aluminium-boron silicate material (FSB strips).



Table 6



Seal	Illustration	Design characteristics	Suitability
Integral RS design		Double-lip rubbing seal of polyurethane (-20 to +80 °C) or polyelastomer (-30 to +130 °C)	<ul style="list-style-type: none"> ✓ for compact bearing arrangements, mainly indoors ✓ for cramped spaces ✓ for high sealing demands when combined with an outboard seal ✓ for long service life with minimum maintenance ✓ for bearings which are to rotate
Integral heavy duty LS design		Triple-lip rubbing seal of elastomer with steel backing (-25 to +120 °C)	<ul style="list-style-type: none"> ✓ for compact bearing arrangements ✓ for high sealing demands ✓ for long service life with minimum maintenance ✓ for rotating bearing arrangements ✓ for difficult operating conditions in the presence of sand or mud
Gap type		Simple and economic, no wear, simple mounting	<ul style="list-style-type: none"> ✓ for maintenance-free bearings ✓ for small angles of tilt ✓ for high temperatures ✓ for moderately dusty environments ✓ for bearings which are to rotate
Gap type with grease		Simple and efficient with periodic relubrication May pollute environment	<ul style="list-style-type: none"> ✓ for bearings and rod ends requiring maintenance ✓ for small angles of tilt ✓ for rough conditions in the presence of sand, clay, slush etc.
V-shaped (commercially available)		Simple, lightly preloaded seal of polyurethane (-40 to +100 °C) Good wear strength and resistance to grease, oil and other environmental influences	<ul style="list-style-type: none"> ✓ for contaminant exclusion ✓ for angles of tilt up to 2° ✓ for bearing arrangements with shafts up to 300 mm diameter ✓ for bearings which are to rotate
V-Ring (commercially available)		Elastic seal which sits on shaft and rotates with it, axial sealing lip of nitrile rubber (-40 to +100 °C) or fluoro rubber (-40 to +200 °C) Good wear and chemical resistance	<ul style="list-style-type: none"> ✓ for contaminant exclusion ✓ for maintenance-free and grease-lubricated bearings ✓ for all shaft diameters ✓ for angles of tilt between 2 and 4° depending on size ✓ for bearings which are to rotate
Felt (commercially available)		Simple to install, good resistance to grease (-40 to +100 °C)	<ul style="list-style-type: none"> ✓ for dust and minor damp exclusion ✓ for grease retention ✓ for large angles of tilt ✓ for all sizes of bearing ✓ for bearings which are to rotate

Table 6

Seal	Illustration	Design characteristics	Suitability
Radial shaft (commercially available)		Steel reinforced (either externally or internally) elastomer with lip of nitrile rubber (-40 to +100 °C) or fluoro rubber (-40 to +200 °C) Good wear resistance, good resistance to grease, oil and other environmental influences	<ul style="list-style-type: none"> ✓ for contaminant exclusion ✓ for grease retention ✓ for oil retention ✓ for small angles of tilt ✓ for all sizes of bearing ✓ for bearings which are to rotate
Radial shaft with dust lip (commercially available)		Steel reinforced (either externally or internally) elastomer with lips of nitrile rubber (-40 to +100 °C) or fluoro rubber (-40 to +200 °C) Good wear resistance, good resistance to grease, oil and other environmental influences	<ul style="list-style-type: none"> ✓ for strong contaminant exclusion ✓ for oil retention ✓ for small angles of tilt ✓ for bearings up to approx. 300 mm bore ✓ for bearings which are to rotate
O-ring (commercially available)		Nitrile rubber (-30 to +100 °C) or fluoro rubber (-20 to +200 °C)	<ul style="list-style-type: none"> ✓ for reliable moisture exclusion ✓ for oil and grease retention ✓ for very small angles of tilt ✓ for slow oscillating movements
Profiled rubber (commercially available)		Polyurethane (-40 to +100 °C) Good wear resistance, good resistance to grease, oil and other environmental influences	<ul style="list-style-type: none"> ✓ for hermetically sealed bearing arrangements ✓ for small angles of tilt ✓ for slow oscillating movements; initial oiling or greasing of faces reduces friction
Profiled rubber with clamp and lock (commercially available)		Elastomer strip (-40 to +100 °C) Good wear resistance, good resistance to grease, oil and other environmental influences	<ul style="list-style-type: none"> ✓ for hermetically sealed bearing arrangements ✓ for slow oscillating movements ✓ for small angles of tilt
Mechanical seals (commercially available)		Stainless steel rings and cup springs of nitrile rubber (-40 to +100 °C) Good wear resistance, good resistance to grease, oil and other environmental influences	<ul style="list-style-type: none"> ✓ for contaminant exclusion ✓ for oil and grease retention ✓ for small angles of tilt ✓ for bearings which are to rotate
Spring steel washers (commercially available)		Labyrinth seals of sets of washers for high temperatures. Excellent wear resistance, good chemical resistance	<ul style="list-style-type: none"> ✓ for contaminant exclusion ✓ grease exit vents needed in housing cover if grease used ✓ for small angles of tilt ✓ for bearings which are to rotate

Designing the bearing arrangement for easy mounting and dismounting

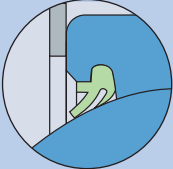
To ease mounting, the shaft ends and housing bores should have a lead-in with an angle of between 10 and 20° (→ **fig 16**). This not only eases mounting but reduces the risk of damaging the mating surfaces by skewing of the bearing rings.

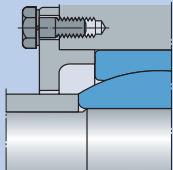
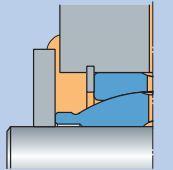
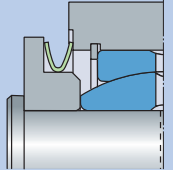
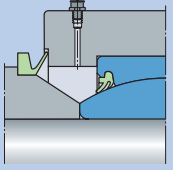
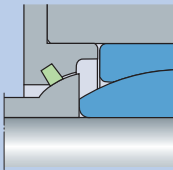
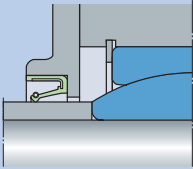
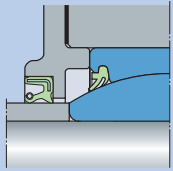
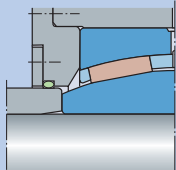
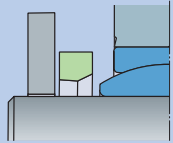
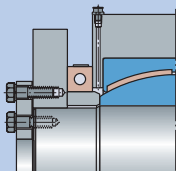
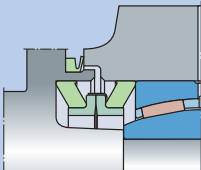
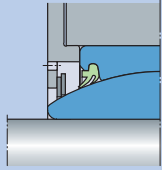
Particularly for large bearings, it is necessary to design the arrangement so that bearing mounting, and especially dismounting, are simplified or even made possible.

To facilitate subsequent removal of a bearing, it can be advantageous to

- provide recesses in the shaft shoulder (→ **fig 17**), and
- recesses or threaded holes in the housing bore (→ **fig 18**)

so that withdrawal tools can be used without difficulty.

To dismount maintenance-free bearings having a bore diameter of some 80 mm and above, it is recommended that the oil injection method be used. This involves introducing oil under high pressure between the bearing inner ring and its shaft seating. This greatly reduces the force required to dismount the bearing and practically eliminates

any risk of damaging the bearing and seating.

In order to employ the oil injection method it is necessary to provide an oil supply duct in the shaft as well as an oil distributor groove in the seating (→ **fig 19**). The distance between this groove and the bearing side from which mounting and dismounting are to be performed should be approximately one third of the seating width. Recommended dimensions for the ducts and grooves as well as for the threads for the oil supply connection are given in **Tables 7** and **8**.

Chamfering shaft ends and housing bore entrances

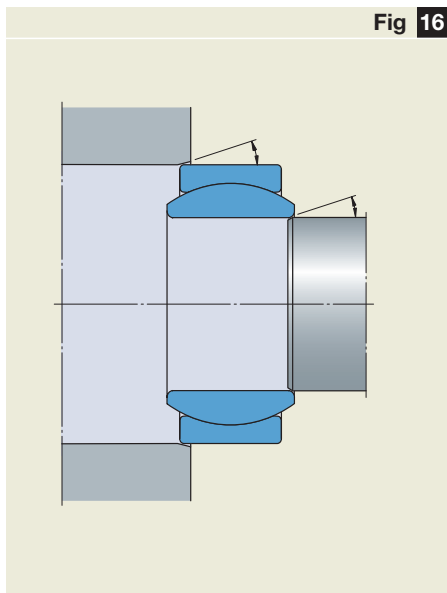

Fig 16

Shaft shoulder with recess

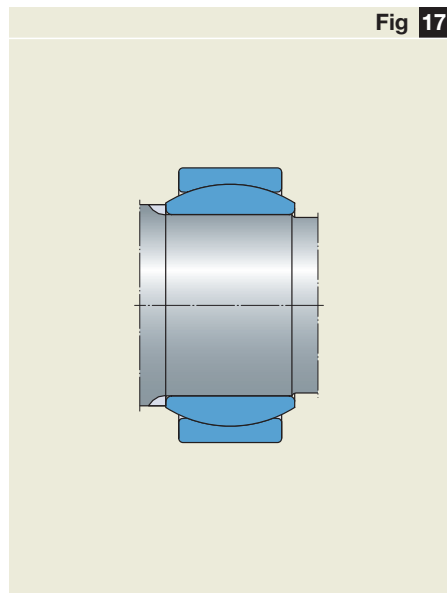

Fig 17

Housing shoulder with threaded holes

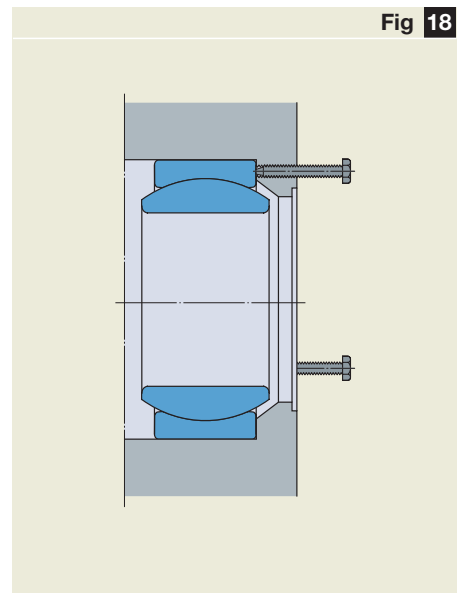

Fig 18

Table 7

Bearing seating diameter over incl.	Dimensions				
	b _a	h _a	r _a	N	
mm	mm				
100	100	3	0,5	2,5	2,5
150	150	4	0,8	3	3
150	200	4	0,8	3	3
200	250	5	1	4	4
250	300	5	1	4	4
300	400	6	1,25	4,5	5
400	500	7	1,5	5	5
500	650	8	1,5	6	6
650	800	10	2	7	7
800	1 000	12	2,5	8	8

Oil ducts and distributor grooves

Table 8

Thread	Design	Dimensions		
		G _b	G _c ¹⁾	N _a max
-		mm		
M6	A	10	8	3
G 1/8	A	12	10	3
G 1/4	A	15	12	5
G 3/8	B	15	12	8
G 1/2	B	18	14	8
G 3/4	B	20	16	8

Threaded holes for connection

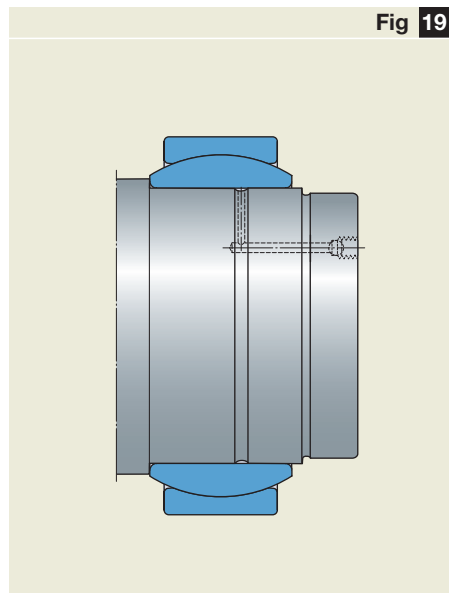

Bearing seating with oil ducts and distributor grooves for easy dismounting

Lubrication

Spherical plain bearings requiring maintenance

Steel-on-steel spherical plain bearings must be maintained and lubricated to

- reduce friction,
- reduce wear,
- extend bearing life,
- protect against corrosion and
- prevent contamination by dirt or moisture.

The sliding contact surfaces are phosphated and treated with a “running-in” lubricant. This special surface treatment has a favourable influence on the running-in phase. In order to obtain the desired rating life the bearings must be greased at the very latest before being taken into operation and must then be regularly relubricated.

Relubrication of the bearing can only be made if the necessary ducts for relubrication are provided in the housing (→ fig 1) or the shaft (pin) (→ fig 2) so that grease can be directly supplied to the bearing. To facilitate efficient lubrication in service, all SKF steel-on-

steel spherical plain bearings (with the exception of the smallest bearings of the E and ESA designs) have an annular groove and lubrication holes in both inner and outer rings.

If the arrangement is appropriately designed, the bearing can be supplied with grease from the side. To compel grease to pass through the bearing it is necessary to prevent the grease from exiting the bearing arrangement from the same side as it is supplied and to provide a grease exit opening at the opposite side (→ fig 3). Where possible, the free space surrounding the bearing should be filled with grease.

It is recommended that the SKF grease LGHB 2 be used to lubricate steel-on-steel spherical plain bearings. This is a high-quality calcium sulphonate base grease. Its properties include

- excellent load carrying capacity,
- very good rust inhibition,
- very good resistance to ageing,
- good water resistance, and
- a wide operating temperature range of -20 to $+150$ °C.

If operating temperatures are higher than this special grease should be used instead, and the SKF application engineering service should be contacted. More information on SKF greases will be found in Table 1.

Maintenance-free spherical plain bearings

Sliding contact surface combinations steel/sinter bronze composite and steel/PTFE fabric

During the first period of operation of these bearings, a transfer of PTFE takes place from the dry sliding contact surface to the opposing surface of the inner ring. Any lubrication of the sliding contact surfaces would disturb this transfer and shorten bearing life. Therefore, lubrication of these bearings, or rod ends with the same sliding contact surface combinations, is not advisable and they have no relubrication facilities.

To provide protection against corrosion and to enhance sealing, the free space surrounding the bearing may,

Relubricating the bearing via the outer ring

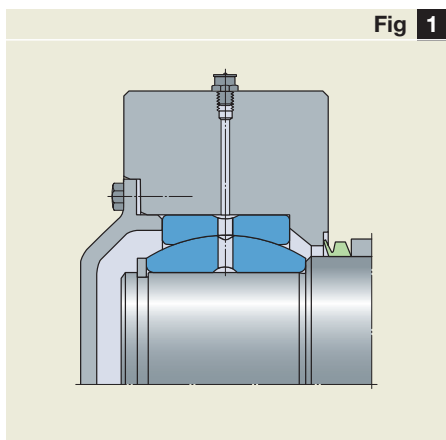

Fig 1

Relubricating the bearing via the inner ring

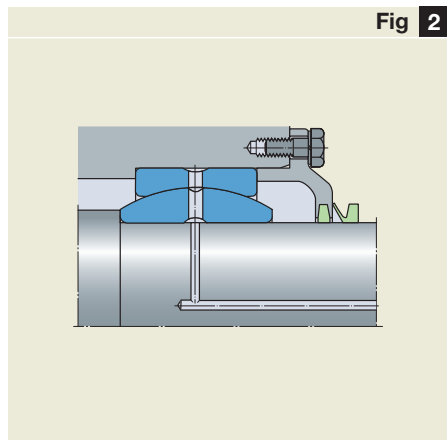

Fig 2

Relubricating the bearing from the side

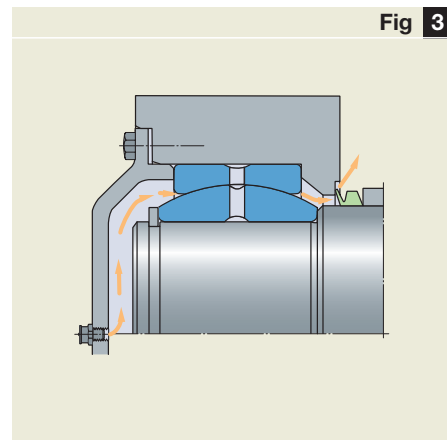

Fig 3

Property	SKF greases (designation)			
	LGHB 2 for sliding contact surface combinations steel-on-steel	LGMT 3 steel-on-bronze	LGEP 2 steel/PTFE composite	LGGB 2 ¹⁾
Thickener	Calcium sulphonate complex soap	Lithium soap	Lithium soap	Lithium/calcium soap
Base oil	Mineral oil	Mineral oil	Mineral oil	Ester oil
Colour	Brown	Yellowish brown	Light brown	White
Operating temperature, °C (continuous operation)	-20 to +150	-30 to +120	-20 to +110	-40 to +120
Kinematic viscosity of base oil, mm²/s at +40 °C at +100 °C	400 to 450 26,5	120 to 130 12	200 16	110 13
Consistency (to NLGI Scale)	2	3	2	2

¹⁾ Biologically degradable grease for use in applications where strict ecological demands must be met and where lubrication cannot be dispensed with

Sliding contact surface combination steel/PTFE composite

An initial lubrication followed by occasional relubrication of steel/PTFE composite bearings can extend the service life by a factor of at least 2. The inner rings and shaft washers of such bearings are coated with lithium base grease before leaving the factory.

If operating conditions are such that protection against corrosion and enhanced sealing are required, the free space surrounding the bearing (→ fig 5) should be filled with the same grease as that used for bearing lubrication. The appropriate time to replenish or renew the grease in the bearing arrangement is determined by the operating conditions and the ageing of the grease.

Rust inhibiting, water-repellant lithium base greases of normal consistency should be used, for example, the SKF grease LGEP 2 (→ Table 1). On no account should greases containing molybdenum disulphide or other solid lubricants be used.

SKF lubricating greases

however, be filled with grease (→ fig 4). Rust inhibiting, water-repellant lithium base greases of normal consistency should be used, for example, the SKF greases LGEP 2 or LGMT 3 (→ Table 1).

Grease supply to free space in the housing surrounding a steel/sinter bronze composite bearing

Grease supply to free space in housing surrounding a large steel/PTFE composite bearing

Note
SKF spherical plain bearings, depending on their design are either completely or partially coated with an oily preservative or filled with grease. Skin contact should be avoided as these substances may give rise to irritation or allergic reactions.

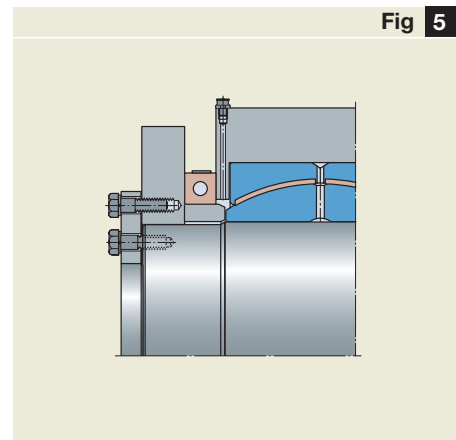
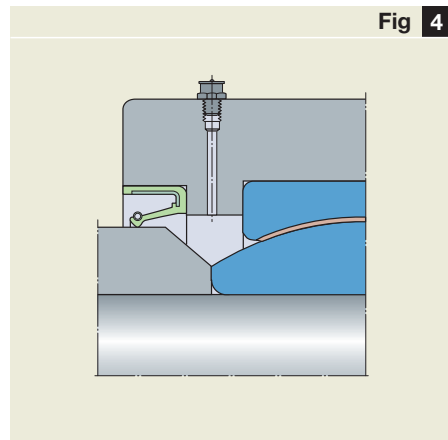

Rod ends requiring maintenance

Rod ends with the sliding contact surface combinations steel-on-steel and steel-on-bronze require maintenance and must be lubricated. To facilitate this

- all SKF steel-on-steel rod ends can be relubricated via a lubrication hole or grease nipple in the rod end housing as well as via the inner ring (→ **fig 6**) with the exception of the small-sized rod ends of the E and ESA designs;
- all SKF steel-on-bronze rod ends can be relubricated via a lubrication hole or grease nipple in the rod end housing (→ **fig 7**).

The recommendations above for steel-on-steel spherical plain bearings also apply to steel-on-bronze rod ends.

These recommendations also apply to the steel-on-bronze rod ends of the SIKAC .. M and SAKAC .. M series where SKF grease LGMT 3 is recommended. It is, however, also possible to use lithium base greases of normal consistency without solid lubricant additives.

Maintenance-free rod ends

Rod ends with maintenance-free sliding contact surface combinations are generally to be used as dry sliding bearings, i.e. they should not be lubricated; the maintenance-free rod ends are without relubrication facilities.

However, the service life of steel/-PTFE composite rod ends can be much extended by an initial application of grease followed by occasional relubrication. The inner ring is already coated with a lithium base grease before leaving the factory.

Note

SKF rod ends, depending on their design are either completely or partially coated with an oily preservative or filled with grease. Skin contact should be avoided as these substances may give rise to irritation or allergic reactions.

Relubrication facilities for steel-on-steel rod ends

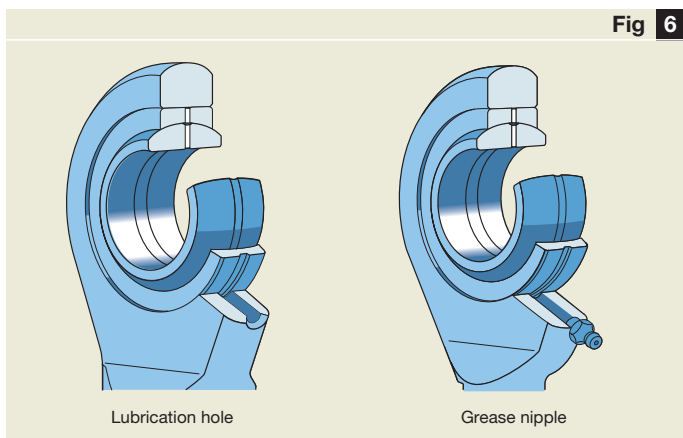

Relubrication facilities for steel-on-bronze rod ends

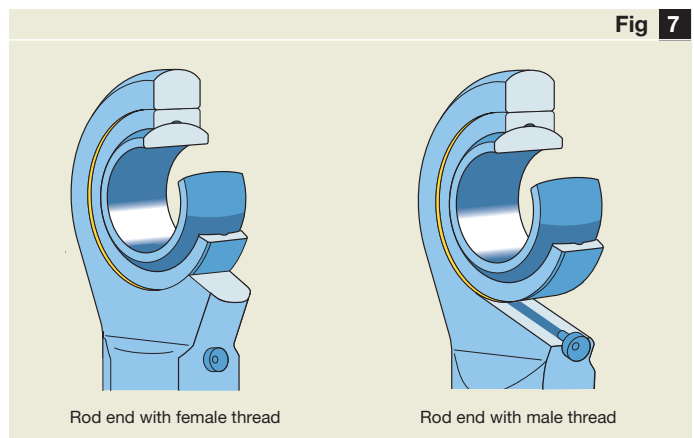

Maintenance

To obtain a long service life with spherical plain bearings and rod ends requiring maintenance, they must be relubricated. Used grease together with wear debris and any contamination should be removed from the contact zone and be replaced by fresh grease.

The relubrication interval should be determined when performing the bearing calculation. The frequency of relubrication is of decisive importance for the attainable service life and depends on many factors including

- the magnitude of the load,
- the type of load,
- the angle of oscillation,
- the frequency of oscillation,
- the operating temperature
- the sealing arrangement and
- other environmental conditions.

Long service lives can be attained when the following relubrication conditions are observed:

- the same grease is used as originally applied;
- the relubrication should be carried out at the operating temperature;
- the bearing should be relubricated before a long interruption in operation occurs, e.g. before construction machinery or agricultural equipment is laid up.

SKF has the correct greases for spherical plain bearings and rod ends, including the biologically degradable grease LGGB 2

Relubrication of non-locating bearings

Non-locating bearings, where axial displacement takes place along the shaft or pin, should always be relubricated via the shaft and bearing inner ring (→ fig 2, page 46). By supplying lubricant in this way grease will also enter between the mating surfaces of inner ring and shaft seating. This reduces friction and consequently the axial forces produced when axial displacement takes place.

Storage

SKF spherical plain bearings and rod ends are treated with a preservative before they are packaged. They can, therefore, be stored in their original packages for several years. However, the relative humidity in the storeroom should not exceed 60 %.



Mounting

Spherical plain bearings

Skill and cleanliness when mounting are necessary if spherical plain bearings and rod ends are to perform correctly and not fail prematurely.

The bearings and rod ends should only be taken from their packages immediately before mounting so that they do not become contaminated. Any components which have possibly become dirty as a result of improper handling (damaged packaging etc.) should be wiped using a clean cloth.

The sliding contact surfaces of the bearings are matched to provide favourable friction and wear characteristics. Any alteration of the sliding surfaces would shorten the service life, therefore, bearings must not be washed or come into contact with solvents, cleaners, oils or similar media.

The components associated with the bearings (housings, shafts or pins etc.) should be cleaned and any burrs removed. They should also be checked with regard to accuracy of dimensions and form before mounting is started.

Simultaneous mounting in housing and on shaft

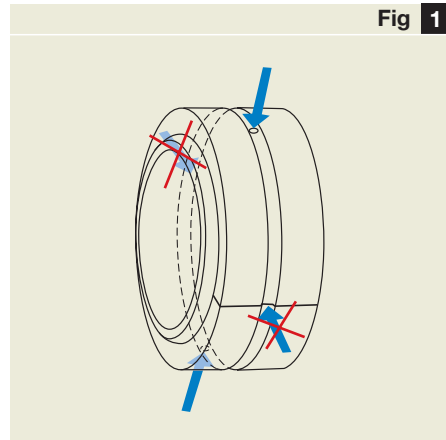
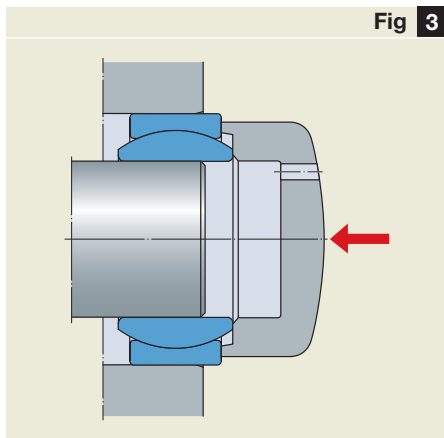

Plane of fracture or split and main direction of load

When mounting spherical plain bearings with a fractured or split outer ring it is essential that the joint be positioned at right angles to the main direction of load (→ fig 1) as otherwise the service life will be shortened, particularly under heavy loads.

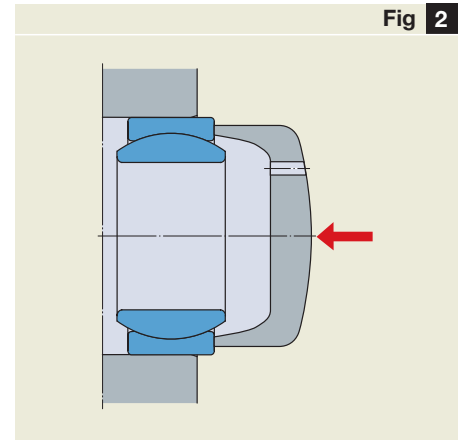

Mounting with the aid of a dolly

Mounting using a press

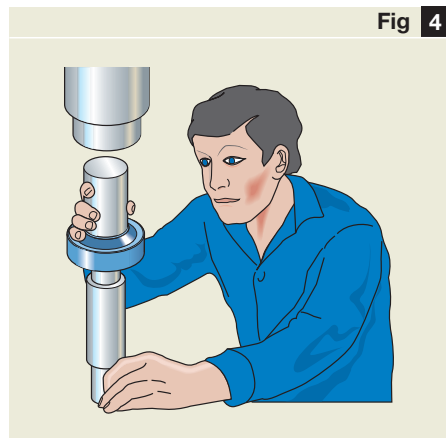

Never direct blows at the bearing rings

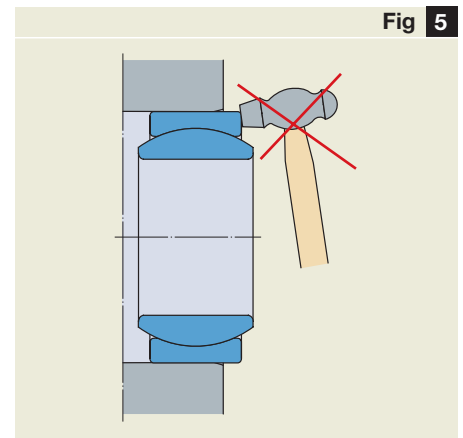

Mechanical mounting

The following tools are suitable for mounting spherical plain bearings

- a mounting dolly (→ **fig 2**) or length of tubing; the ring having an interference fit should generally be mounted first;
- a dolly having two abutment surfaces (→ **fig 3**) for mounting simultaneously on the shaft and in the housing;
- for larger numbers of bearings, suitable tools can be used in combination with a press (→ **fig 4**).

When mounting spherical plain bearings,

- on no account should blows be directed at the bearing rings (→ **fig 5**); the use of a hammer and drift can also easily damage the rings;
- the mounting force should never be directed through the sliding contact surfaces (→ **fig 6**); this could
 - damage the sliding contact surfaces and/or
 - expand fractured or split bearing outer rings, which would cause an increase in the mounting force required.

Never apply the mounting force via the sliding contact surfaces

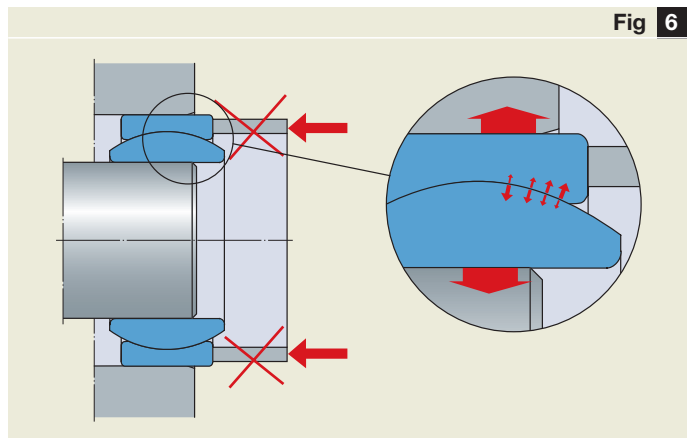

Fig 6

Mounting using heat

Larger bearings cannot usually be mounted in the cold state as the force required increases sharply with increasing bearing size. Therefore, the bearing or housing should be heated before mounting (→ **fig 7**).

The requisite temperature difference between the bearing ring and shaft or housing bore depends on the seating diameter. Generally, a temperature of 60 to 80 °C above ambient is adequate to allow the rings to be easily mounted. The temperature to which a bearing can be heated also depends on the permissible temperature for the bearing which may be limited, for example, by the material of the seals.

Note

Maintenance-free spherical plain bearings and rod ends having sliding contact surfaces containing PTFE should never be subjected to temperatures in excess of +280 °C. PTFE is completely inert below this temperature but at higher temperatures (from approx. 320 °C) it rapidly decomposes. The fluorine compounds released during this process are extremely toxic, even in small quantities. It should also be remembered that the material is dangerous to handle once it has been overheated even after it has cooled down again.

Mounting a heated bearing

Fig 7

The use of SKF induction heaters has been found particularly beneficial (→ **fig 8**). They are equipped with integral protection against overheating and automatically demagnetize. The induced current flow serves to rapidly heat the bearing. The non-metallic components, such as seals or PTFE fabric remain cold as does the heater itself.

To ease the mounting of large bearings, particularly if they have been heated, it is possible to use slings and a hoist. Metal or textile slings placed around the outer ring can be used (→ **fig 9**). A spring between the hoist hook and the sling also facilitates bearing handling. Heat-resistant gloves should be worn when handling hot components.

Rod ends

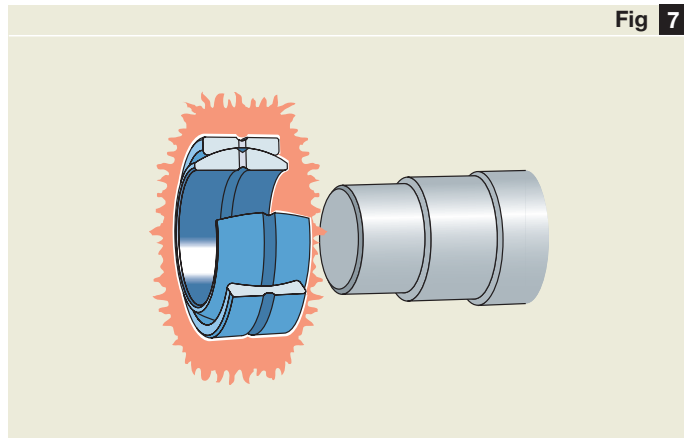
Rod ends are fitted on the pins in the same way as spherical plain bearings. Slight heating will reduce the force required for mounting and reduce the danger of damaging associated components.

When attaching rod ends to threaded rods or in extension tubes (→ **fig 11**) a counter lock nut should be used on the rod or on the external thread of the rod end. It should be securely tightened against the abutment surface on the rod end or the tube.

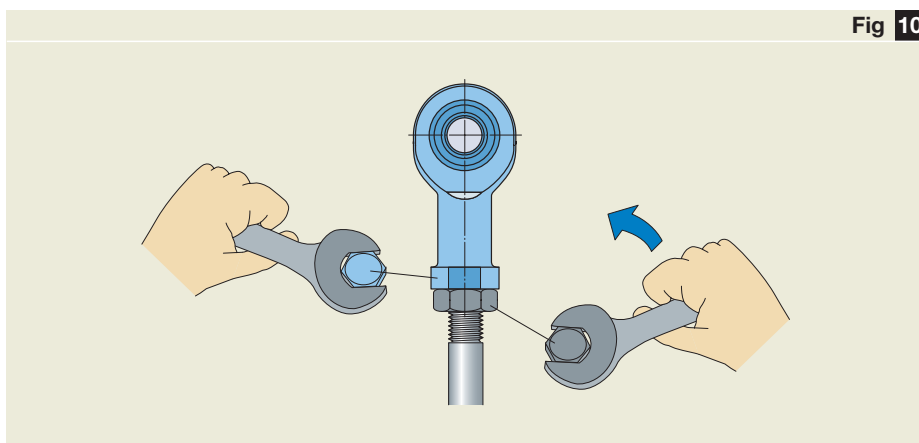

Fig 10

Securing a rod end

A bearing in position on an SKF induction heater

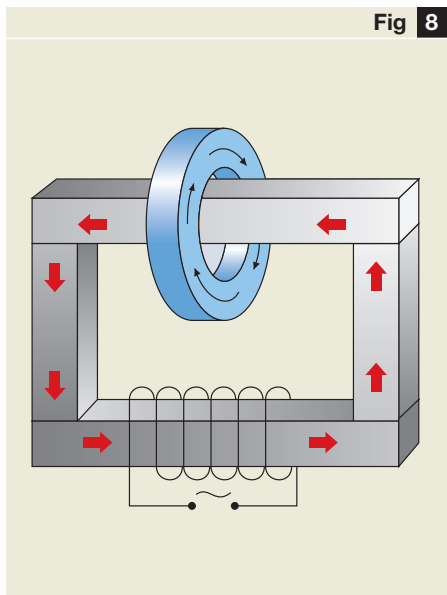

Fig 8

Mounting a large heated bearing

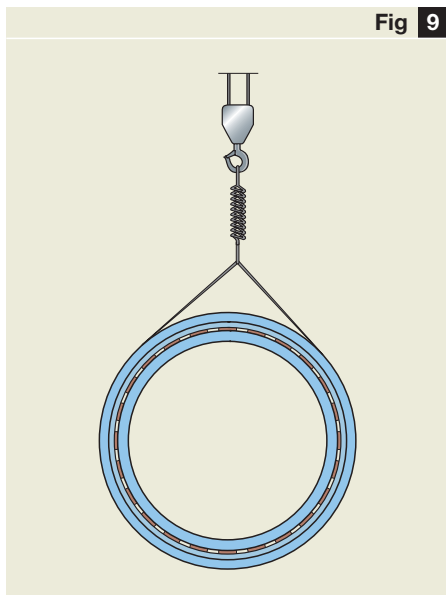

Fig 9

SKF has a comprehensive range of mechanical and hydraulic tools as well as heating equipment for bearing mounting and dismantling. Details of these tools can be found in the SKF catalogue MP3000 "SKF Maintenance and Lubrication Products" or in the online catalogue at www.mapro.skf.com.

Dismounting

Spherical plain bearings

If the bearings are to be re-used after dismounting, the same care and attention are required as when mounting. The requisite withdrawal force should always be applied to the ring which is to be dismounted.

SKF offers a range of different puller types to accommodate many applications. If the shaft is pre-machined to accommodate the arms of a jaw puller, then a two- or three-armed puller can be used (→ **fig 1**). In other cases where there is enough space behind the ring, a strong back puller such as the SKF TMBS series can be used (→ **fig 2**).

For large bearings with an interference fit, dismounting is considerably facilitated if the SKF oil injection method is used (→ **fig 3**). In order to do this it is necessary to provide the necessary oil ducts and distributor grooves when designing the bearing arrangement (→ **page 46**).

Small bearings can be dismounted using a mounting dolly or a length of tubing applied to the outer ring. For larger bearings with an interference fit, a mechanical or hydraulic press can be used where possible.

It is also possible to dismount bearings from housing bores by quickly heating the bearing housing without heating the bearing outer ring to any extent.

Rod ends

To dismount rod ends the lock nut securing the shank should be loosened and, if possible, the rod end be unscrewed from its rod or tube. The rod end can then be removed from the pin in the same way as a bearing, e.g. using a puller.

Removing a bearing with a jaw puller

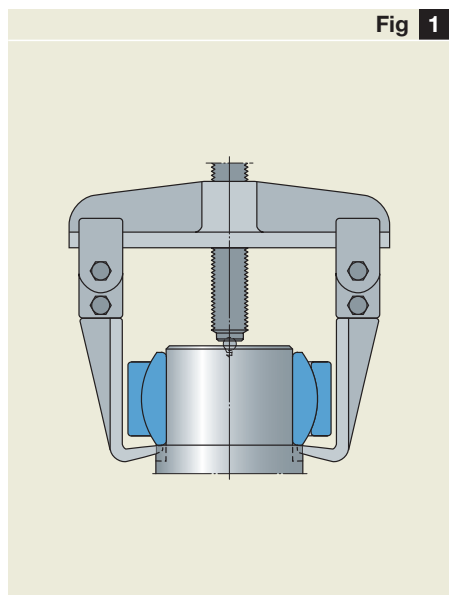

A strong back puller facilitates dismounting of the inner ring

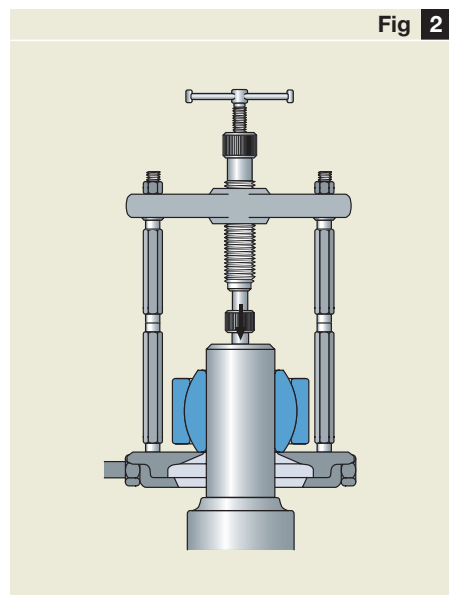

Dismounting a bearing using the SKF oil injection method

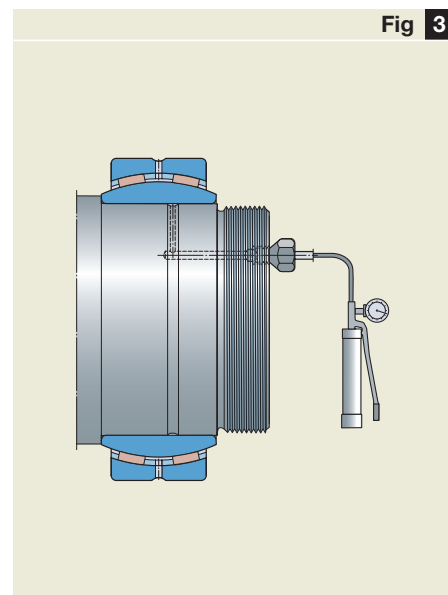



Bearing data – general

3 Product data 57

Radial spherical plain bearings

requiring maintenance 58

General 58

Steel-on-steel spherical plain bearings

with metric dimensions 62

with inch dimensions 66

with extended inner ring 70

Maintenance-free radial spherical plain bearings 72

General 72

Bearings with sliding contact surface combination

steel/sinter bronze composite 76

steel/PTFE fabric 78

steel/PTFE composite 82

Angular contact spherical plain bearings 86

General 86

Maintenance-free bearings with sliding contact

surface combination steel/PTFE composite 90

Spherical plain thrust bearings 92

General 92

Maintenance-free bearings with sliding contact

surface combination steel/PTFE composite 94

Rod ends requiring maintenance 96

General 96

Steel-on-steel rod ends

with female thread 100

with female thread for hydraulic cylinders 102

with male thread 104

with cylindrical section welding shank 106

with rectangular section welding shank 108

Steel-on-bronze rod ends

with female thread 110

with male thread 112

Maintenance-free rod ends 114

General 114

Maintenance-free rod ends

with female thread, steel/sinter bronze composite 118

with male thread, steel/sinter bronze composite 120

with female thread, steel/PTFE fabric 122

with male thread, steel/PTFE fabric 124

with female thread, steel/PTFE composite 126

with male thread, steel/PTFE composite 128

Special solutions and related products 130

Plain bearings for road vehicles 130

Plain bearings for rail vehicles 130

Spherical plain bearings and rod ends for

airframe applications 131

Dry sliding bushings and flanged bushings 132

Dry sliding thrust washers and strip 133

Radial spherical plain bearings

requiring maintenance 58

Maintenance-free

radial spherical plain bearings 72

Angular contact spherical plain bearings 86

Spherical plain thrust bearings 92

Rod ends requiring maintenance 96

Maintenance-free rod ends 114

Special solutions and related products 130

3

3.1

3.2

3.3

3.4

3.5

3.6

3.7

Radial spherical plain bearings requiring maintenance

A characteristic feature of the SKF steel-on-steel spherical plain bearings is the outer ring, which is intentionally fractured at a given point so that it can be sprung apart to enable the inner ring to be inserted (→ **fig 1**). The bearings are therefore non-separable and easy to handle.

The surfaces are manganese phosphated and the sliding contact surface also treated with a running-in lubricant. This makes the bearings wear resistant and easy to run-in. To facilitate effective lubrication, all bearings – except some small sizes – have an annular groove and two lubrication holes in both outer and inner rings. Additionally, bearings with an outside diameter of 150 mm and above also have the “multi-groove system” (→ **page 6**) in the outer ring sliding contact surface as standard (→ **fig 2**).

With the multi-groove system SKF has the answer to lubricant starvation in steel-on-steel bearings, which is otherwise prevalent where the bearings have to perform minor alignment movements under heavy constant direction loads.

The multi-groove system (→ **fig 3**) improves lubricant distribution in the heavy loaded zone and thus extends the service life and/or maintenance intervals.



Dimensions

The dimensions of spherical plain bearings of series GE, GEH and GEG conform to ISO 12240-1:1998.

Bearings with cylindrical extensions to the inner ring, series GEM, have a non-standard inner ring width but otherwise have the dimensions of series GE bearings.

The dimensions of spherical plain bearings with inch dimensions, series GEZ, conform to the American Standard ANSI/ABMA Std. 22.2-1988.

Tolerances

The tolerances to which metric radial spherical plain bearings are made are given in **Table 1** and those of inch-size bearings are given in **Table 2** on **page 60**. Outer ring tolerances apply to conditions before fracture and surface treatment. Accordingly, inner ring tolerances apply to rings before surface treatment.

The tolerances are in accordance with ISO 12240-1:1998 (metric) and ANSI/ABMA Std. 22.2-1988 (inch-size bearings).

The symbols used in the tolerance tables are explained in the following.

- d nominal bore diameter
- Δ_{dmp} deviation of the mean bore diameter from the nominal
- D nominal outside diameter
- Δ_{Dmp} deviation of the mean outside diameter from the nominal
- Δ_{Bs} deviation of single inner ring width from the nominal
- Δ_{Cs} deviation of single outer ring width from the nominal

Radial spherical plain bearings requiring maintenance

Insertion of inner ring into outer ring

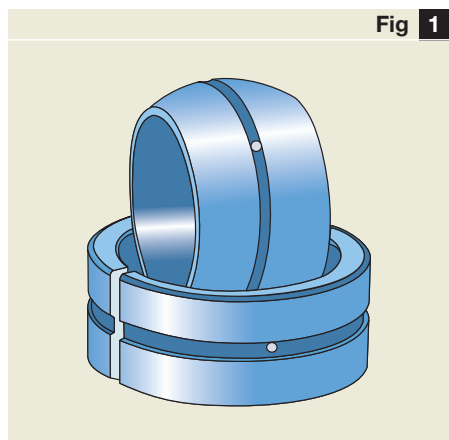

Outer ring with multi-groove lubrication system in heavy duty ESL design



Heavy-duty spherical plain bearing with multi-groove lubrication system and LS seals

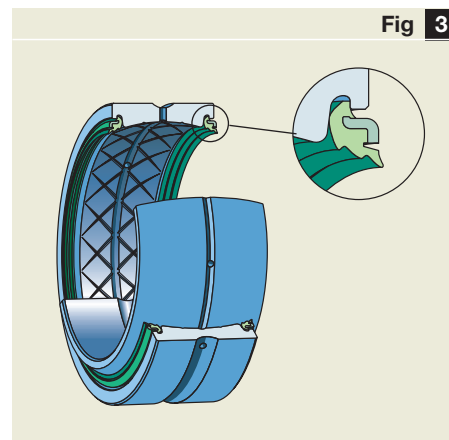

**Tolerances of
metric bearings**

Table 1

Nominal diameter		Series GE, GEH, GEM Inner ring				Series GEG Inner ring				All series Outer ring			
d, D		Δ_{dmp}		Δ_{Bs}		Δ_{dmp}		Δ_{Bs}		Δ_{Dmp}		Δ_{Cs}	
over	incl.	high	low	high	low	high	low	high	low	high	low	high	low
mm		μm		μm		μm		μm		μm		μm	
6	6	0	-8	0	-120	-	-	-	-	-	-	-	-
6	10	0	-8	0	-120	-	-	-	-	0	-8	0	-240
10	18	0	-8	0	-120	+18	0	0	-180	0	-8	0	-240
18	30	0	-10	0	-120	+21	0	0	-210	0	-9	0	-240
30	50	0	-12	0	-120	+25	0	0	-250	0	-11	0	-240
50	80	0	-15	0	-150	+30	0	0	-300	0	-13	0	-300
80	120	0	-20	0	-200	+35	0	0	-350	0	-15	0	-400
120	150	0	-25	0	-250	+40	0	0	-400	0	-18	0	-500
150	180	0	-25	0	-250	+40	0	0	-400	0	-25	0	-500
180	250	0	-30	0	-300	+46	0	0	-460	0	-30	0	-600
250	315	0	-35	0	-350	-	-	-	-	0	-35	0	-700
315	400	-	-	-	-	-	-	-	-	0	-40	0	-800
400	500	-	-	-	-	-	-	-	-	0	-45	0	-900

**Tolerances of
inch-size bearings**

Table 2

Nominal diameter		Inner ring		Outer ring		Δ_{Dmp}		Δ_{Cs}	
d, D		Δ_{dmp}		Δ_{Bs}		Δ_{Dmp}		Δ_{Cs}	
over	incl.	high	low	high	low	high	low	high	low
mm		μm		μm		μm		μm	
50,8	50,8	0	-13	0	-130	0	-13	0	-130
76,2	76,2	0	-15	0	-130	0	-15	0	-130
76,2	80,962	0	-20	0	-130	0	-15	0	-130
80,962	120,65	0	-20	0	-130	0	-20	0	-130
120,65	152,4	0	-25	0	-130	0	-25	0	-130
152,4	177,8	-	-	-	-	0	-25	0	-130
177,8	222,25	-	-	-	-	0	-30	0	-130

Table 3

Bore diameter d over incl.		Radial internal clearance					
		C2		Normal		C3	
		min	max	min	max	min	max
mm		µm					
Metric bearings¹⁾							
12	12	8	32	32	68	68	104
	20	10	40	40	82	82	124
20	35	12	50	50	100	100	150
35	60	15	60	60	120	120	180
60	90	18	72	72	142	142	212
90	140	18	85	85	165	165	245
140	200	18	100	100	192	192	284
200	240	18	110	110	214	214	318
240	300	18	125	125	239	239	353
Inch-size bearings							
	15,875	15	75	50	150	150	200
15,875	50,800	25	105	80	180	180	260
50,800	76,200	30	130	100	200	200	300
76,200	152,400	40	160	130	230	230	350

¹⁾ Bearings of series GEH with bore diameter d = 20, 35, 60 and 90 mm have a radial internal clearance corresponding to the values quoted for the next larger diameter range

Radial internal clearance

Steel-on-steel spherical plain bearings are produced with Normal radial internal clearance as standard; the actual values are shown in **Table 3**. The availability of bearings with radial internal clearance smaller than Normal, C2, or greater than Normal, C3, should be checked before ordering.

The clearance values for the metric bearings conform to ISO 12240-1:1998.

Materials

The inner and outer rings of SKF steel-on-steel radial spherical plain bearings are made of through-hardened steel, ground and phosphated. The sliding contact surfaces are treated with a running-in lubricant.

The double-lip rubbing seals of metric bearings with designation suffix 2RS are made of polyester elastomer. Polyurethane is used for the seals of the inch-size bearings.

Bearings with designation suffix 2LS have a triple lip elastomer seal, with a steel backing, on each side of the bearing.

Permissible operating temperature range

Steel-on steel spherical plain bearings can be used in the temperature range of -50 to +300 °C, but their load carrying capacity will be reduced at temperatures above +150 °C.

For sealed bearings, the permissible operating temperature range is limited by the seal material,

for 2RS seals

- -30 to +130 °C for polyester elastomer (metric bearings), and
- -20 to +80 °C for polyurethane (inch-size bearings),

for 2LS seals

- -25 to +120 °C for metric bearings.

The operating temperature range for the actual grease used to lubricate the bearings must also be taken into consideration.

Radial internal clearance of steel-on-steel spherical plain bearings

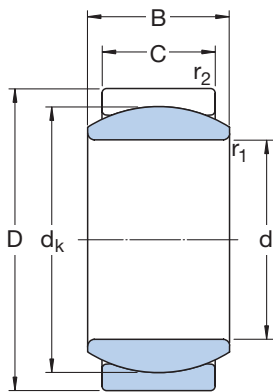

GE .. E

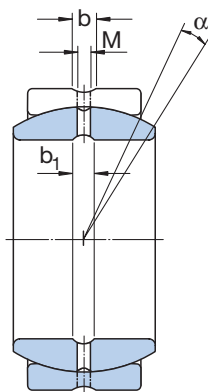

GE .. ES

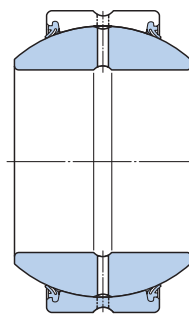

GEH .. ES-2RS

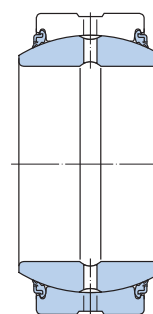

GE .. ES-2LS

Principal dimensions				Angle of tilt ¹⁾ α	Basic load ratings		Mass	Designation	
d	D	B	C		dynamic C	static C ₀		Standard design	Heavy duty ²⁾ design
mm				degrees	kN		kg	-	
4	12	5	3	16	2,04	10,2	0,003	GE 4 E	-
5	14	6	4	13	3,4	17	0,004	GE 5 E	-
6	14	6	4	13	3,4	17	0,004	GE 6 E	-
8	16	8	5	15	5,5	27,5	0,008	GE 8 E	-
10	19	9	6	12	8,15	40,5	0,012	GE 10 E	-
12	22	10	7	10	10,8	54	0,017	GE 12 E	-
15	26	12	9	8	17	85	0,032	GE 15 ES	-
	26	12	9	8	17	85	0,032	GE 15 ES-2RS	-
17	30	14	10	10	21,2	106	0,050	GE 17 ES	-
	30	14	10	10	21,2	106	0,050	GE 17 ES-2RS	-
20	35	16	12	9	30	146	0,065	GE 20 ES	-
	35	16	12	9	30	146	0,065	GE 20 ES-2RS	-
	42	25	16	17	48	240	0,16	GEH 20 ES-2RS	-
25	42	20	16	7	48	240	0,12	GE 25 ES	-
	42	20	16	7	48	240	0,12	GE 25 ES-2RS	-
	47	28	18	17	62	310	0,20	GEH 25 ES-2RS	GEH 25 ES-2LS
30	47	22	18	6	62	310	0,16	GE 30 ES	-
	47	22	18	6	62	310	0,16	GE 30 ES-2RS	GE 30 ES-2LS
	55	32	20	17	80	400	0,35	GEH 30 ES-2RS	GEH 30 ES-2LS
35	55	25	20	6	80	400	0,23	GE 35 ES	-
	55	25	20	6	80	400	0,23	GE 35 ES-2RS	GE 35 ES-2LS
	62	35	22	15	100	500	0,47	GEH 35 ES-2RS	GEH 35 ES-2LS
40	62	28	22	7	100	500	0,32	GE 40 ES	-
	62	28	22	6	100	500	0,32	GE 40 ES-2RS	GE 40 ES-2LS
	68	40	25	17	127	640	0,61	GEH 40 ES-2RS	GEH 40 ES-2LS
45	68	32	25	7	127	640	0,46	GE 45 ES	-
	68	32	25	7	127	640	0,46	GE 45 ES-2RS	GE 45 ES-2LS
	75	43	28	14	156	780	0,80	GEH 45 ES-2RS	GEH 45 ES-2LS
50	75	35	28	6	156	780	0,56	GE 50 ES	-
	75	35	28	6	156	780	0,56	GE 50 ES-2RS	GE 50 ES-2LS
	90	56	36	17	245	1 220	1,60	GEH 50 ES-2RS	GEH 50 ES-2LS

¹⁾ To fully utilize the angle of tilt, the shaft shoulder should not be made larger than $d_{a \max}$.

²⁾ Bearings with outside diameter ≥ 150 mm have the multi-groove lubrication system in the outer ring as standard (\rightarrow page 6)

Bearings with outside diameter < 150 mm can also be supplied with multi-groove features; the designation then becomes GE .. ESL-2LS

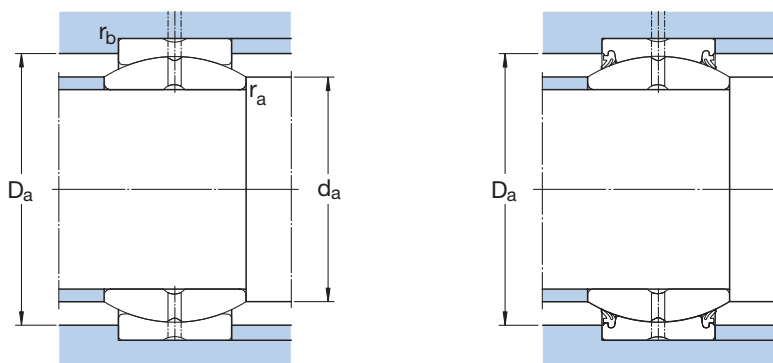

Dimensions

Abutment and fillet dimensions

d	d _k	b	b ₁	M	r ₁ min	r ₂ min	d _a min	d _a max	D _a max	D _a min	r _a max	r _b max
mm							mm					
4	8	-	-	-	0,3	0,3	5,5	6,2	10,7	7,6	0,3	0,3
5	10	-	-	-	0,3	0,3	6,6	8	12,6	9,5	0,3	0,3
6	10	-	-	-	0,3	0,3	7,5	8	12,6	9,5	0,3	0,3
8	13	-	-	-	0,3	0,3	9,6	10,2	14,5	12,3	0,3	0,3
10	16	-	-	-	0,3	0,3	11,7	13,2	17,5	15,2	0,3	0,3
12	18	-	-	-	0,3	0,3	13,8	15	20,4	17,1	0,3	0,3
15	22	2,3	2,3	1,5	0,3	0,3	16,9	18,4	24,3	20,9	0,3	0,3
	22	2,3	2,3	1,5	0,3	0,3	16,9	18,4	24,3	22,8	0,3	0,3
17	25	2,3	2,3	1,5	0,3	0,3	19	20,7	28,3	23,7	0,3	0,3
	25	2,3	2,3	1,5	0,3	0,3	19	20,7	28,3	26	0,3	0,3
20	29	3,1	3,1	2	0,3	0,3	22,1	24,2	33,2	27,6	0,3	0,3
	29	3,1	3,1	2	0,3	0,3	22,1	24,2	33,2	30,9	0,3	0,3
	35,5	3,1	3,1	2	0,3	0,6	22,7	25,2	39,2	36,9	0,3	0,6
25	35,5	3,1	3,1	2	0,6	0,6	28,2	29,3	39,2	33,7	0,6	0,6
	35,5	3,1	3,1	2	0,6	0,6	28,2	29,3	39,2	36,9	0,6	0,6
	40,7	3,1	3,1	2	0,6	0,6	28,6	29,5	44	41,3	0,6	0,6
30	40,7	3,1	3,1	2	0,6	0,6	33,3	34,2	44	38,7	0,6	0,6
	40,7	3,1	3,1	2	0,6	0,6	33,3	34,2	44	41,3	0,6	0,6
	47	3,9	3,9	2,5	0,6	1	33,7	34,4	50,9	48,5	0,6	1
35	47	3,9	3,9	2,5	0,6	1	38,5	39,8	50,9	44,6	0,6	1
	47	3,9	3,9	2,5	0,6	1	38,5	39,8	50,9	48,5	0,6	1
	53	3,9	3,9	2,5	0,6	1	38,8	39,8	57,8	54,5	0,6	1
40	53	3,9	3,9	2,5	0,6	1	43,6	45	57,8	50,3	0,6	1
	53	3,9	3,9	2,5	0,6	1	43,6	45	57,8	54,5	0,6	1
	60	4,6	4,6	3	0,6	1	44,1	44,7	63,6	61	0,6	1
45	60	4,6	4,6	3	0,6	1	49,4	50,8	63,6	57	0,6	1
	60	4,6	4,6	3	0,6	1	49,4	50,8	63,6	61	0,6	1
	66	4,6	4,6	3	0,6	1	49,8	50,1	70,5	66,2	0,6	1
50	66	4,6	4,6	3	0,6	1	54,6	56	70,5	62,7	0,6	1
	66	4,6	4,6	3	0,6	1	54,6	56	70,5	66,2	0,6	1
	80	6,2	6,2	4	0,6	1	55,8	57,1	84,2	79,7	0,6	1

Steel-on-steel spherical plain bearings
d 60 – 300 mm

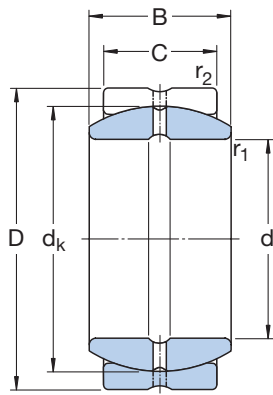

GE .. ES

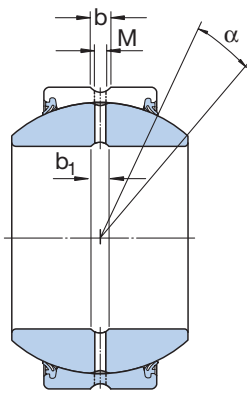

GEH .. ES-2RS

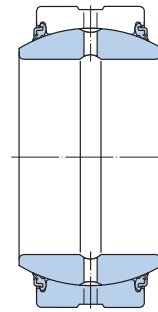

GE .. ES-2LS

Principal dimensions				Angle of tilt ¹⁾ α	Basic load ratings		Mass	Designation	
d	D	B	C		dynamic C	static C ₀		Standard design	Heavy duty ²⁾ design
mm				degrees	kN		kg	–	
60	90	44	36	6	245	1 220	1,10	GE 60 ES	–
	90	44	36	6	245	1 220	1,10	GE 60 ES-2RS	GE 60 ES-2LS
	105	63	40	17	315	1 560	2,40	GEH 60 ES-2RS	GEH 60 ES-2LS
70	105	49	40	6	315	1 560	1,55	GE 70 ES	–
	105	49	40	6	315	1 560	1,55	GE 70 ES-2RS	GE 70 ES-2LS
	120	70	45	16	400	2 000	3,40	GEH 70 ES-2RS	GEH 70 ES-2LS
80	120	55	45	6	400	2 000	2,30	GE 80 ES	–
	120	55	45	5	400	2 000	2,30	GE 80 ES-2RS	GE 80 ES-2LS
	130	75	50	14	490	2 450	4,10	GEH 80 ES-2RS	GEH 80 ES-2LS
90	130	60	50	5	490	2 450	2,75	GE 90 ES	–
	130	60	50	5	490	2 450	2,75	GE 90 ES-2RS	GE 90 ES-2LS
	150	85	55	15	610	3 050	6,30	GEH 90 ES-2RS	GEH 90 ES-2LS
100	150	70	55	7	610	3 050	4,40	GE 100 ES	–
	150	70	55	6	610	3 050	4,40	GE 100 ES-2RS	GE 100 ES-2LS
	160	85	55	13	655	3 250	6,80	GEH 100 ES-2RS	GEH 100 ES-2LS
110	160	70	55	6	655	3 250	4,80	GE 110 ES	–
	160	70	55	6	655	3 250	4,80	GE 110 ES-2RS	GE 110 ES-2LS
	180	100	70	12	950	4 750	11,0	GEH 110 ES-2RS	GEH 110 ES-2LS
120	180	85	70	6	950	4 750	8,25	GE 120 ES	–
	180	85	70	6	950	4 750	8,25	GE 120 ES-2RS	GE 120 ES-2LS
	210	115	70	16	1 080	5 400	15,0	GEH 120 ES-2RS	–
140	210	90	70	7	1 080	5 400	11,0	GE 140 ES	–
	210	90	70	7	1 080	5 400	11,0	GE 140 ES-2RS	–
160	230	105	80	8	1 370	6 800	14,0	GE 160 ES	–
	230	105	80	8	1 370	6 800	14,0	GE 160 ES-2RS	–
180	260	105	80	6	1 530	7 650	18,5	GE 180 ES	–
	260	105	80	6	1 530	7 650	18,5	GE 180 ES-2RS	–
200	290	130	100	7	2 120	10 600	28,0	GE 200 ES	–
	290	130	100	7	2 120	10 600	28,0	GE 200 ES-2RS	–
220	320	135	100	8	2 320	11 600	35,5	GE 220 ES-2RS	–
240	340	140	100	8	2 550	12 700	40,0	GE 240 ES-2RS	–
260	370	150	110	7	3 050	15 300	51,5	GE 260 ES-2RS	–
280	400	155	120	6	3 550	18 000	65,0	GE 280 ES-2RS	–
300	430	165	120	7	3 800	19 000	78,5	GE 300 ES-2RS	–

¹⁾ To fully utilize the angle of tilt, the shaft shoulder should not be made larger than $d_{a\max}$

²⁾ Bearings with outside diameter ≥ 150 mm have the multi-groove lubrication system in the outer ring as standard (→ page 6)

Bearings with outside diameter < 150 mm can also be supplied with multi-groove features; the designation then becomes GE .. ESL-2LS

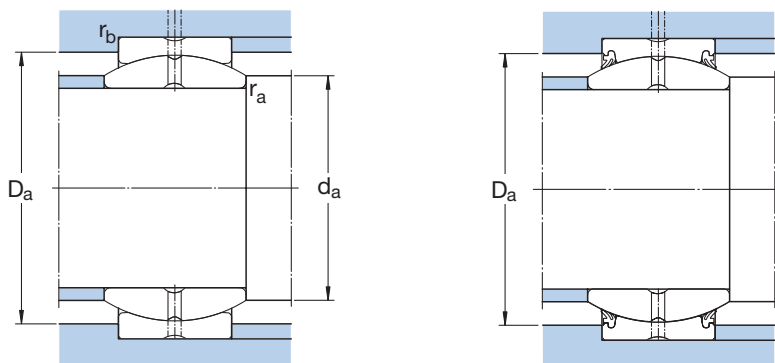

Dimensions

Abutment and fillet dimensions

d	d _k	b	b ₁	M	r ₁ min	r ₂ min	d _a min	d _a max	D _a max	D _a min	r _a max	r _b max
mm							mm					
60	80	6,2	6,2	4	1	1	66,4	66,8	84,2	76	1	1
	80	6,2	6,2	4	1	1	66,4	66,8	84,2	79,7	1	1
	92	7,7	7,7	4	1	1	67	67	99	92	1	1
70	92	7,7	7,7	4	1	1	76,7	77,9	99	87,4	1	1
	92	7,7	7,7	4	1	1	76,7	77,9	99	92	1	1
	105	7,7	7,7	4	1	1	77,5	78,3	113,8	104,4	1	1
80	105	7,7	7,7	4	1	1	87,1	89,4	113,8	99,7	1	1
	105	7,7	7,7	4	1	1	87,1	89,4	113,8	104,4	1	1
	115	9,5	9,5	5	1	1	87,2	87,2	123,5	112,9	1	1
90	115	9,5	9,5	5	1	1	97,4	98,1	123,5	109,3	1	1
	115	9,5	9,5	5	1	1	97,4	98,1	123,5	112,9	1	1
	130	11,3	11,3	5	1	1	98,2	98,4	143,2	131	1	1
100	130	11,3	11,3	5	1	1	107,8	109,5	143,2	123,5	1	1
	130	11,3	11,3	5	1	1	107,8	109,5	143,2	131	1	1
	140	11,5	11,5	5	1	1	108,1	111,2	153,3	141,5	1	1
110	140	11,5	11,5	5	1	1	118	121	153	133	1	1
	140	11,5	11,5	5	1	1	118	121	153	141,5	1	1
	160	13,5	13,5	6	1	1	119,5	124,5	172	157,5	1	1
120	160	13,5	13,5	6	1	1	129,5	135,5	172	152	1	1
	160	13,5	13,5	6	1	1	129,5	135,5	172	157,5	1	1
	180	13,5	13,5	6	1	1	130	138,5	202,5	180	1	1
140	180	13,5	13,5	6	1	1	149	155,5	202,5	171	1	1
	180	13,5	13,5	6	1	1	149	155,5	202,5	180	1	1
160	200	13,5	13,5	6	1	1	169,5	170	222	190	1	1
	200	13,5	13,5	6	1	1	169,5	170	222	197	1	1
180	225	13,5	13,5	6	1,1	1,1	191	199	250,5	214	1	1
	225	13,5	13,5	6	1,1	1,1	191	199	250,5	224,5	1	1
200	250	15,5	15,5	7	1,1	1,1	212,5	213,5	279,5	237,5	1	1
	250	15,5	15,5	7	1,1	1,1	212,5	213,5	279,5	244,5	1	1
220	275	15,5	15,5	7	1,1	1,1	232,5	239,5	309,5	271	1	1
240	300	15,5	15,5	7	1,1	1,1	252,5	265	329,5	298	1	1
260	325	15,5	15,5	7	1,1	1,1	273	288	359	321,5	1	1
280	350	15,5	15,5	7	1,1	1,1	294	313,5	388,5	344,5	1	1
300	375	15,5	15,5	7	1,1	1,1	314	336,5	418,5	371	1	1

3.1

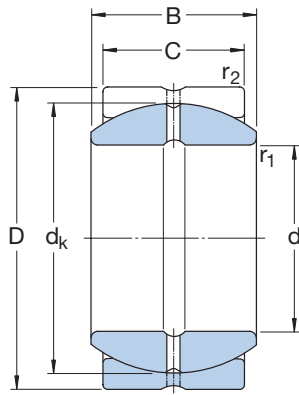

GEZ .. ES

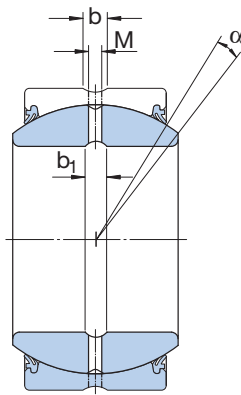

GEZ .. ES-2RS

Principal dimensions				Angle of tilt ¹⁾	Basic load ratings		Mass	Designation
d	D	B	C	α	C	C ₀		
mm/in				degrees	kN		kg	-
12,700 0,5000	22,225 0,8750	11,100 0,4370	9,525 0,3750	6	14	41,5	0,020	GEZ 008 ES
15,875 0,6250	26,988 1,0625	13,894 0,5470	11,913 0,4690	6	21,6	65,5	0,035	GEZ 010 ES
19,050 0,7500	31,750 1,2500	16,662 0,6560	14,275 0,5620	6	31,5	93	0,055	GEZ 012 ES
22,225 0,8750	36,513 1,4375	19,431 0,7650	16,662 0,6560	6	42,5	127	0,085	GEZ 014 ES
25,400 1,0000	41,275 1,6250	22,225 0,8750	19,050 0,7500	6	56	166	0,12	GEZ 100 ES
	41,275 1,6250	22,225 0,8750	19,050 0,7500	6	56	166	0,12	GEZ 100 ES-2RS
31,750 1,2500	50,800 2,0000	27,762 1,0930	23,800 0,9370	6	86,5	260	0,23	GEZ 104 ES
	50,800 2,0000	27,762 1,0930	23,800 0,9370	6	86,5	260	0,23	GEZ 104 ES-2RS
34,925 1,3750	55,563 2,1875	30,150 1,1870	26,187 1,0310	5	104	310	0,35	GEZ 106 ES
	55,563 2,1875	30,150 1,1870	26,187 1,0310	5	104	310	0,35	GEZ 106 ES-2RS
38,100 1,5000	61,913 2,4375	33,325 1,3120	28,575 1,1250	6	125	375	0,42	GEZ 108 ES
	61,913 2,4375	33,325 1,3120	28,575 1,1250	6	125	375	0,42	GEZ 108 ES-2RS
44,450 1,7500	71,438 2,8125	38,887 1,5310	33,325 1,3120	6	170	510	0,64	GEZ 112 ES
	71,438 2,8125	38,887 1,5310	33,325 1,3120	6	170	510	0,64	GEZ 112 ES-2RS
50,800 2,0000	80,963 3,1875	44,450 1,7500	38,100 1,5000	6	224	670	0,93	GEZ 200 ES
	80,963 3,1875	44,450 1,7500	38,100 1,5000	6	224	670	0,93	GEZ 200 ES-2RS
57,150 2,2500	90,488 3,5625	50,013 1,9690	42,850 1,6870	6	280	850	1,30	GEZ 204 ES
	90,488 3,5625	50,013 1,9690	42,850 1,6870	6	280	850	1,30	GEZ 204 ES-2RS
63,500 2,5000	100,013 3,9375	55,550 2,1870	47,625 1,8750	6	345	1 040	1,85	GEZ 208 ES
	100,013 3,9375	55,550 2,1870	47,625 1,8750	6	345	1 040	1,85	GEZ 208 ES-2RS

¹⁾ To fully utilize the angle of tilt, the shaft shoulder should not be made larger than d_{a max}

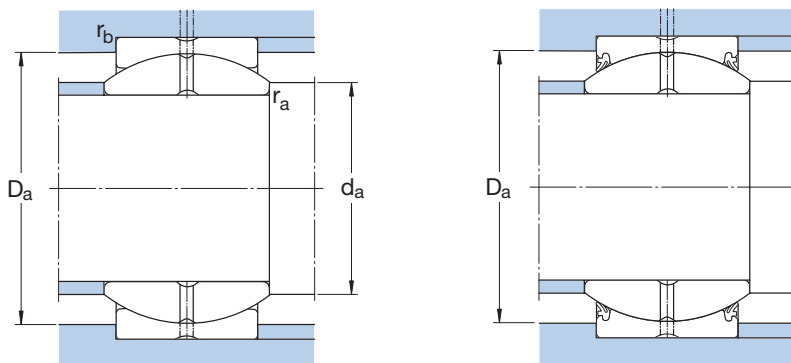

Dimensions

Abutment and fillet dimensions

d	dk	b	b ₁	M	r ₁ min	r ₂ min	d _a min	d _a max	D _a max	D _a min	r _a max	r _b max
mm/in							mm/in					
12,700 0,5000	18,263 0,719	2,6 0,102	2,5 0,098	1,5 0,059	0,15 0,006	0,6 0,024	13,7 0,539	14,5 0,571	19,9 0,783	17,3 0,681	0,15 0,006	0,6 0,024
15,875 0,6250	22,835 0,899	3,2 0,126	3 0,118	2,5 0,098	0,15 0,006	1 0,039	17 0,669	18,1 0,713	23,6 0,929	21,7 0,854	0,15 0,006	1 0,039
19,050 0,7500	27,432 1,080	3,2 0,126	3 0,118	2,5 0,098	0,3 0,012	1 0,039	20,9 0,823	21,8 0,858	28,3 1,114	26,1 1,028	0,3 0,012	1 0,039
22,225 0,8750	31,953 1,258	3,2 0,126	3 0,118	2,5 0,098	0,3 0,012	1 0,039	24,2 0,953	25,4 1,000	33 1,299	30,4 1,197	0,3 0,012	1 0,039
25,400 1,0000	36,5 1,437	3,2 0,126	3 0,118	2,5 0,098	0,3 0,012	1 0,039	27,5 1,083	29 1,142	37,7 1,484	34,7 1,366	0,3 0,012	1 0,039
	36,5 1,437	3,2 0,126	3 0,118	2,5 0,098	0,3 0,012	1 0,039	27,5 1,083	29 1,142	37,7 1,484	35,2 1,386	0,3 0,012	1 0,039
31,750 1,2500	45,593 1,795	4,8 0,189	5 0,197	4 0,158	0,6 0,024	1 0,039	34,8 1,370	36,2 1,425	47 1,850	43,3 1,705	0,6 0,024	1 0,039
	45,593 1,795	4,8 0,189	5 0,197	4 0,158	0,6 0,024	1 0,039	34,8 1,370	36,2 1,425	47 1,850	44,8 1,764	0,6 0,024	1 0,039
34,925 1,3750	49,2 1,937	4,8 0,189	5 0,197	4 0,158	0,6 0,024	1 0,039	38,1 1,500	38,9 1,531	51,7 2,035	46,7 1,839	0,6 0,024	1 0,039
	49,2 1,937	4,8 0,189	5 0,197	4 0,158	0,6 0,024	1 0,039	38,1 1,500	38,9 1,531	51,7 2,035	47,1 1,854	0,6 0,024	1 0,039
38,100 1,5000	54,737 2,155	4,8 0,189	5 0,197	4 0,158	0,6 0,024	1 0,039	41,4 1,630	43,4 1,709	58 2,283	52 2,047	0,6 0,024	1 0,039
	54,737 2,155	4,8 0,189	5 0,197	4 0,158	0,6 0,024	1 0,039	41,4 1,630	43,4 1,709	58 2,283	52,3 2,059	0,6 0,024	1 0,039
44,450 1,7500	63,881 2,515	4,8 0,189	5 0,197	4 0,158	0,6 0,024	1 0,039	48,5 1,909	50,7 1,996	67,4 2,654	60,7 2,390	0,6 0,024	1 0,039
	63,881 2,515	4,8 0,189	5 0,197	4 0,158	0,6 0,024	1 0,039	48,5 1,909	50,7 1,996	67,4 2,654	61,3 2,413	0,6 0,024	1 0,039
50,800 2,0000	73,025 2,875	4,8 0,189	5 0,197	4 0,158	0,6 0,024	1 0,039	55,1 2,169	57,9 2,280	75,9 2,988	69,4 2,732	0,6 0,024	1 0,039
	73,025 2,875	4,8 0,189	5 0,197	4 0,158	0,6 0,024	1 0,039	55,1 2,169	57,9 2,280	75,9 2,988	69,1 2,720	0,6 0,024	1 0,039
57,150 2,2500	82,169 3,235	5,7 0,224	5 0,197	4 0,158	0,6 0,024	1 0,039	61,7 2,429	65,2 2,567	85,3 3,358	78,1 3,075	0,6 0,024	1 0,039
	82,169 3,235	5,7 0,224	5 0,197	4 0,158	0,6 0,024	1 0,039	61,7 2,429	65,2 2,567	85,3 3,358	79 3,110	0,6 0,024	1 0,039
63,500 2,5000	91,186 3,590	9 0,354	8 0,315	6,5 0,256	0,6 0,024	1 0,039	68,3 2,689	72,3 2,846	94,7 3,728	86,6 3,409	0,6 0,024	1 0,039
	91,186 3,590	9 0,354	8 0,315	6,5 0,256	0,6 0,024	1 0,039	68,3 2,689	72,3 2,846	94,7 3,728	87 3,425	0,6 0,024	1 0,039

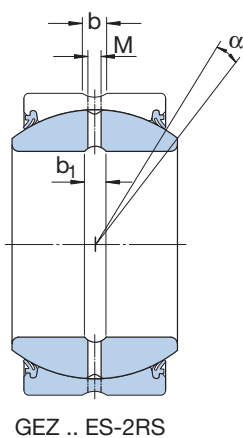
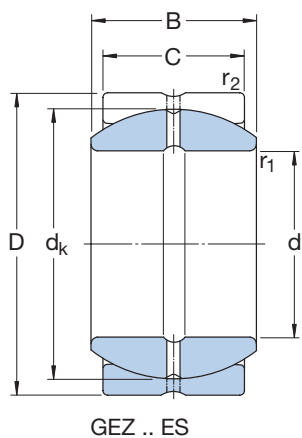

Principal dimensions

Angle of tilt¹⁾

Basic load ratings
dynamic static

Mass

Designation

d	D	B	C	α	C	C ₀	kg	
mm/in				degrees	kN			-
69,850 2,7500	111,125	61,112	52,375	6	425	1 270	2,40	GEZ 212 ES
	4,3750	2,4060	2,0620					
	111,125	61,112	52,375	6	425	1 270	2,40	GEZ 212 ES-2RS
	4,3750	2,4060	2,0620					
76,200 3,0000	120,650	66,675	57,150	6	500	1 500	3,10	GEZ 300 ES
	4,7500	2,6250	2,2500					
	120,650	66,675	57,150	6	500	1 500	3,10	GEZ 300 ES-2RS
	4,7500	2,6250	2,2500					
82,550 3,2500	130,175	72,238	61,900	6	585	1 760	3,80	GEZ 304 ES
	5,1250	2,8440	2,4370					
	130,175	72,238	61,900	6	585	1 760	3,80	GEZ 304 ES-2RS
	5,1250	2,8440	2,4370					
88,900 3,5000	139,700	77,775	66,675	6	680	2 040	4,80	GEZ 308 ES
	5,5000	3,0620	2,6250					
	139,700	77,775	66,675	6	680	2 040	4,80	GEZ 308 ES-2RS
	5,5000	3,0620	2,6250					
95,250 3,7500	149,225	83,337	71,425	6	780	2 360	5,80	GEZ 312 ES
	5,8750	3,2810	2,8120					
	149,225	83,337	71,425	6	780	2 360	5,80	GEZ 312 ES-2RS
	5,8750	3,2810	2,8120					
101,600 4,0000	158,750	88,900	76,200	6	900	2 650	7,00	GEZ 400 ES
	6,2500	3,5000	3,0000					
	158,750	88,900	76,200	6	900	2 650	7,00	GEZ 400 ES-2RS
	6,2500	3,5000	3,0000					
114,300 4,5000	177,800	100	85,725	6	1 120	3 400	9,80	GEZ 408 ES
	7,0000	3,9370	3,3750					
	177,800	100	85,725	6	1 120	3 400	9,80	GEZ 408 ES-2RS
	7,0000	3,9370	3,3750					
120,650 4,7500	187,325	105,562	90,475	6	1 250	3 750	11,5	GEZ 412 ES
	7,3750	4,1560	3,5620					
	187,325	105,562	90,475	6	1 250	3 750	11,5	GEZ 412 ES-2RS
	7,3750	4,1560	3,5620					
127 5,0000	196,850	111,125	95,250	6	1 400	4 150	13,5	GEZ 500 ES
	7,7500	4,3750	3,7500					
	196,850	111,125	95,250	6	1 400	4 150	13,5	GEZ 500 ES-2RS
	7,7500	4,3750	3,7500					
152,400 6,0000	222,250	120,650	104,775	5	1 730	5 200	17,5	GEZ 600 ES
	8,7500	4,7500	4,1250					
	222,250	120,650	104,775	5	1 730	5 200	17,5	GEZ 600 ES-2RS
	8,7500	4,7500	4,1250					

¹⁾ To fully utilize the angle of tilt, the shaft shoulder should not be made larger than d_{a max}

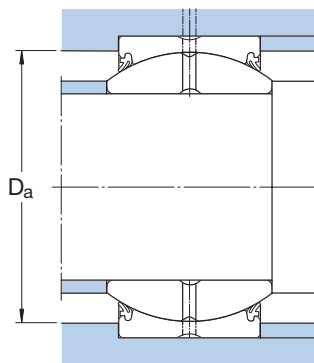
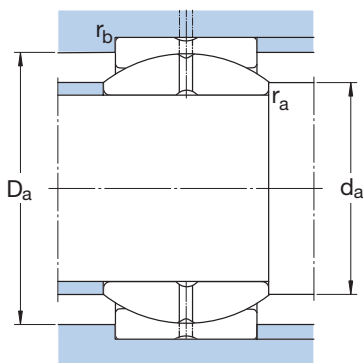

Dimensions

Abutment and fillet dimensions

d	d _k	b	b ₁	M	r ₁ min	r ₂ min	d _a min	d _a max	D _a max	D _a min	r _a max	r _b max
mm/in							mm/in					
69,850	100,330	9	8	6,5	0,6	1	74,9	79,6	105,7	95,3	0,6	1
2,7500	3,950	0,354	0,315	0,256	0,024	0,039	2,949	3,134	4,161	3,752	0,024	0,039
	100,330	9	8	6,5	0,6	1	74,9	79,6	105,7	96	0,6	1
	3,950	0,354	0,315	0,256	0,024	0,039	2,949	3,134	4,161	3,780	0,024	0,039
76,200	109,525	9	8	6,5	0,6	1	81,4	86,9	115	104	0,6	1
3,0000	4,312	0,354	0,315	0,256	0,024	0,039	3,205	3,421	4,528	4,094	0,024	0,039
	109,525	9	8	6,5	0,6	1	81,4	86,9	115	104,8	0,6	1
	4,312	0,354	0,315	0,256	0,024	0,039	3,205	3,421	4,528	4,126	0,024	0,039
82,550	118,745	9,3	8	6,5	0,6	1	88	94,2	124,4	112,8	0,6	1
3,2500	4,675	0,366	0,315	0,256	0,024	0,039	3,465	3,709	4,898	4,441	0,024	0,039
	118,745	9,3	8	6,5	0,6	1	88	94,2	124,4	114,2	0,6	1
	4,675	0,366	0,315	0,256	0,024	0,039	3,465	3,709	4,898	4,496	0,024	0,039
88,900	128,016	10,5	8	6,5	0,6	1	94,6	101,7	133,8	121,6	0,6	1
3,5000	5,040	0,413	0,315	0,256	0,024	0,039	3,724	4,004	5,268	4,787	0,024	0,039
	128,016	10,5	8	6,5	0,6	1	94,6	101,7	133,8	122,8	0,6	1
	5,040	0,413	0,315	0,256	0,024	0,039	3,724	4,004	5,268	4,835	0,024	0,039
95,250	136,906	10,5	8	6,5	0,6	1	101,2	108,6	143,1	130,1	0,6	1
3,7500	5,390	0,413	0,315	0,256	0,024	0,039	3,984	4,276	5,634	5,122	0,024	0,039
	136,906	10,5	8	6,5	0,6	1	101,2	108,6	143,1	131,4	0,6	1
	5,390	0,413	0,315	0,256	0,024	0,039	3,984	4,276	5,634	5,173	0,024	0,039
101,600	146,050	10,5	10	8	0,6	1	108	115,5	152,5	139	0,6	1
4,0000	5,750	0,413	0,394	0,315	0,024	0,039	4,252	4,547	6,004	5,472	0,024	0,039
	146,050	10,5	10	8	0,6	1	108	115,5	152,5	139,5	0,6	1
	5,750	0,413	0,394	0,315	0,024	0,039	4,252	4,547	6,004	5,492	0,024	0,039
114,300	164,465	11	10	8	1	1,1	122,5	130,5	171	156,5	1	1
4,5000	6,475	0,433	0,394	0,315	0,039	0,043	4,823	5,138	6,732	6,161	0,039	0,039
	164,465	11	10	8	1	1,1	122,5	130,5	171	157	1	1
	6,475	0,433	0,394	0,315	0,039	0,043	4,823	5,138	6,732	6,181	0,039	0,039
120,650	173,355	11	10	8	1	1,1	129	137,5	179	165	1	1
4,7500	6,825	0,433	0,394	0,315	0,039	0,043	5,079	5,413	7,047	6,496	0,039	0,039
	173,355	11	10	8	1	1,1	129	137,5	179	166,5	1	1
	6,825	0,433	0,394	0,315	0,039	0,043	5,079	5,413	7,047	6,555	0,039	0,039
127	182,626	11	10	8	1	1,1	135,5	144,5	188,5	173,5	1	1
5,0000	7,190	0,433	0,394	0,315	0,039	0,043	5,335	5,689	7,421	6,831	0,039	0,039
	182,626	11	10	8	1	1,1	135,5	144,5	188,5	175,5	1	1
	7,190	0,433	0,394	0,315	0,039	0,043	5,335	5,689	7,421	6,909	0,039	0,039
152,400	207,162	15	11	8	1	1,1	161	168	213,5	197	1	1
6,0000	8,156	0,591	0,433	0,315	0,039	0,043	6,339	6,614	8,406	7,756	0,039	0,039
	207,162	15	11	8	1	1,1	161	168	213,5	197,5	1	1
	8,156	0,591	0,433	0,315	0,039	0,043	6,339	6,614	8,406	7,776	0,039	0,039

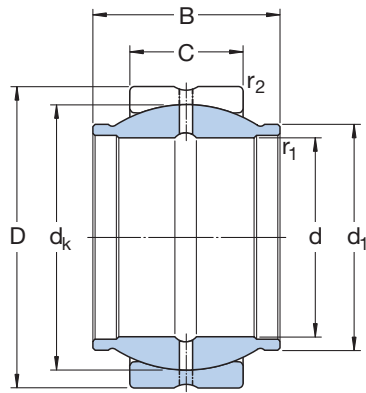
**Steel-on-steel spherical
plain bearings
with extended inner ring**
 d 12 – 200 mm

GEG .. ES

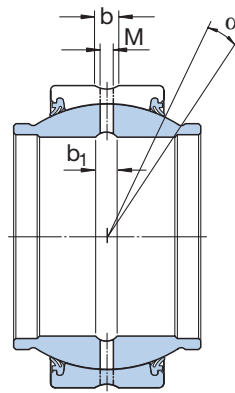

GEM .. ES-2RS

Principal dimensions				Angle of tilt α	Basic load ratings		Mass	Designation ¹⁾
d	D	B	C		dynamic	static		
				degrees	C	C ₀		
mm					kN		kg	–
12	22	12	7	4	10,8	54	0,020	GEG 12 ESA²⁾
16	28	16	9	4	17,6	88	0,035	GEG 16 ES
20	35	20	12	4	30	146	0,070	GEG 20 ES
	35	24	12	6	30	146	0,073	GEM 20 ES-2RS
25	42	25	16	4	48	240	0,13	GEG 25 ES
	42	29	16	4	48	240	0,13	GEM 25 ES-2RS
30	47	30	18	4	62	310	0,17	GEM 30 ES-2RS
32	52	32	18	4	65,5	325	0,17	GEG 32 ES
35	55	35	20	4	80	400	0,25	GEM 35 ES-2RS
40	62	38	22	4	100	500	0,35	GEM 40 ES-2RS
	62	40	22	4	100	500	0,34	GEG 40 ES
45	68	40	25	4	127	640	0,49	GEM 45 ES-2RS
50	75	43	28	4	156	780	0,60	GEM 50 ES-2RS
	75	50	28	4	156	780	0,56	GEG 50 ES
60	90	54	36	3	245	1 220	1,15	GEM 60 ES-2RS
63	95	63	36	4	255	1 270	1,25	GEG 63 ES
70	105	65	40	4	315	1 560	1,65	GEM 70 ES-2RS
80	120	74	45	4	400	2 000	2,50	GEM 80 ES-2RS
	120	80	45	4	400	2 000	2,40	GEG 80 ES
100	150	100	55	4	610	3 050	4,80	GEG 100 ES
125	180	125	70	4	950	4 750	8,50	GEG 125 ES
160	230	160	80	4	1 370	6 800	16,5	GEG 160 ES
200	290	200	100	4	2 120	10 600	32,0	GEG 200 ES

¹⁾ Bearings with outside diameters ≥ 150 mm have the multi-groove lubrication system in the outer ring sliding contact surface as standard (→ page 6)

²⁾ Can only be relubricated via the outer ring

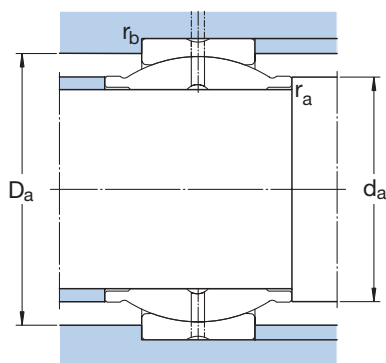

Dimensions

Abutment and fillet dimensions

d	d _k	d ₁	b	b ₁	M	r ₁ min	r ₂ min	d _a min	d _a max	D _a max	D _a min	r _a max	r _b max
mm								mm					
12	18	15,5	2,3	–	1,5	0,3	0,3	14,5	15,5	20,4	17,1	0,3	0,3
16	23	20	2,3	2,3	1,5	0,3	0,3	18,7	20	26,3	21,9	0,3	0,3
20	29	25	3,1	3,1	2	0,3	0,3	23,1	25	33,2	27,6	0,3	0,3
	29	24	3,1	3,1	2	0,3	0,3	23	24	33,2	30,9	0,3	0,3
25	35,5	30,5	3,1	3,1	2	0,6	0,6	29,2	30,5	39,2	33,7	0,6	0,6
	35,5	29	3,1	3,1	2	0,3	0,6	28,3	29	39,2	36,9	0,3	0,6
30	40,7	34	3,1	3,1	2	0,3	0,6	33,5	34	44	41,3	0,3	0,6
32	43	38	3,9	3,9	2,5	0,6	1	36,3	38	48,1	40,9	0,6	1
35	47	40	3,9	3,9	2,5	0,6	1	38,8	40	50,9	48,5	0,6	1
40	53	45	3,9	3,9	2,5	0,6	1	44	45	57,8	54,5	0,6	1
	53	46	3,9	3,9	2,5	0,6	1	44,8	46	57,8	50,3	0,6	1
45	60	52	4,6	4,6	3	0,6	1	49,6	52	63,6	61	0,6	1
50	66	57	4,6	4,6	3	0,6	1	54,8	57	70,5	66,2	0,6	1
	66	57	4,6	4,6	3	0,6	1	55,9	57	70,5	62,7	0,6	1
60	80	68	6,2	6,2	4	0,6	1	65,4	68	84,2	79,7	0,6	1
63	83	71,5	6,2	6,2	4	1	1	69,7	71,5	89,2	78,9	1	1
70	92	78	7,7	7,7	4	0,6	1	75,7	78	99	92	0,6	1
80	105	90	7,7	7,7	4	0,6	1	86,1	90	113,8	104,4	0,6	1
	105	91	7,7	7,7	4	1	1	88,7	91	113,8	99,7	1	1
100	130	113	11,3	11,3	5	1	1	110,1	113	143,2	123,5	1	1
125	160	138	13,5	13,5	6	1	1	136,5	138	172	152	1	1
160	200	177	13,5	13,5	6	1	1	172	177	222	190	1	1
200	250	221	15,5	15,5	7	1,1	1,1	213	221	279,5	237,5	1	1

Maintenance-free radial spherical plain bearings

SKF maintenance-free spherical plain bearings are produced in a variety of designs and a wide range of sizes. Three sliding contact surface combinations are available:



- steel/sinter bronze composite, suffix C
- steel/PTFE fabric, suffix TX
- steel/PTFE composite, suffix F

The different designs of SKF maintenance-free spherical plain bearings are presented in **Matrix 1**. The designs used depend on size and series, the main differences being in the material or in the design of the outer ring.

Materials

The materials for inner ring, outer ring, sliding layer and, where applicable, for the double-lip rubbing seals, are listed in **Matrix 1**. The sliding contact surface of the inner rings of series GEC and GEP bearings are coated with a lithium base grease.

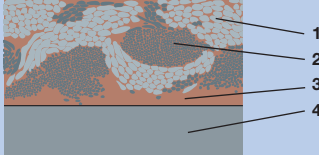
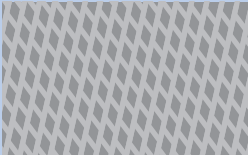
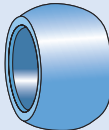
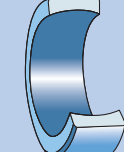

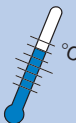
Sliding contact surface combination	Steel/sinter bronze composite	Steel/PTFE fabric	Steel/PTFE composite
Liner	 <ul style="list-style-type: none"> 1 PTFE 2 Tin bronze 3 Copper layer 4 Sheet steel backing 	 <ul style="list-style-type: none"> 1 PTFE fibres 2 Reinforcement fibres 3 Resin 4 Backing 	 <p>Glass fibre reinforced plastic containing PTFE</p>
Inner ring	 <p>C and CJ2 designs Through hardened and ground steel, sliding surface hard chromium plated and polished</p>	<p>TXA and TXE designs Through hardened and ground steel, sliding surface hard chromium plated and polished</p> <p>TXG3E and TXG3A designs Stainless steel X 46 Cr 13/1.4034, hardened, ground, sliding surface polished</p>	<p>Series GEP and GEC Carbon chromium steel 100 Cr 6/1.3505, hardened, ground, sliding surface of series GEP hard chromium plated</p>
Outer ring	 <p>C design Sinter bronze composite moulded around the inner ring, with a butt joint</p> <p>CJ2 design Unhardened free cutting steel with sliding sleeve of sinter bronze composite pressed around the inner ring, without a butt joint.</p>	<p>TXA and TXE designs Through hardened and ground steel TXA: split two-piece, held together by one or two steel bands TXE: fractured at one point</p> <p>TXG3A design Stainless steel X 46 Cr 13/1.4034, hardened, ground, split two-piece, held together by one steel band</p> <p>TXGR design d ≤ 17 mm: unhardened stainless steel X 22 CrNi 17/1.4057, pressed over the inner ring, no butt joint d ≥ 20 mm: hardened stainless steel X 46 Cr 13/1.4034, hardened, ground, fractured at one position</p>	<p>Series GEP and GEC Series GEP: unhardened heat treatable steel C35/1.0501, ground, radially split. A liner of glass fibre reinforced plastic containing PTFE is glued in position in each outer ring half.</p> <p>Series GEC: Unhardened heat treatable steel C35/1.0501, ground. With sliding discs made of glass fibre reinforced plastic containing PTFE held by a cage made of unhardened steel C35/1.0501, which is pinned and screwed together with the outer ring.</p>
Seals	To order	 <p>Bearings with designation suffix 2RS or 2LS (depending on bearing size) have double or triple lip seals on both sides</p>	None
Operating temperature range	 <p>Permissible: -50 to +180 °C For short periods: to +280 °C</p> <p>Reduced carrying capacity above 80 °C</p>	<p>Bearings without seals: Permissible: -50 to +150 °C Sealed bearings: Permissible: -30 to +130 °C RS -25 to +120 °C LS</p> <p>Reduced carrying capacity above 60 °C for both sealed and unsealed bearings</p>	<p>Permissible: -40 to +75 °C For short periods: to +110 °C</p> <p>Reduced carrying capacity above 50 °C</p>
Lubrication	To enhance sealing and protect against corrosion the free space in the housing may be filled with grease	The bearings must not be lubricated	Occasional relubrication is beneficial and extends service life

Dimensions

The dimensions of the maintenance-free spherical plain bearings conform to ISO 12240-1:1998.

Tolerances

The tolerances to which maintenance-free radial spherical plain bearings are made are given in **Table 1**; they are in accordance to ISO 12240/1:1998. The symbols used are explained in the following.

- d nominal bore diameter
- Δ_{dmp} deviation of the mean bore diameter from the nominal
- D nominal outside diameter
- Δ_{Dmp} deviation of the mean outside diameter from the nominal
- Δ_{Bs} deviation of single inner ring width from the nominal
- Δ_{Cs} deviation of single outer ring width from the nominal

Radial internal clearance, preload

Maintenance free spherical plain bearings with a bore diameter up to and including 90 mm may have an internal clearance or a slight preload (negative clearance) because of their design. For these bearings, therefore, only the permissible maximum limit for bearing clearance is given in the table, and also only the permissible upper limit for the frictional moment depending on the preload in the circumferential direction under measuring load.

The radial internal clearance and the upper limit of the permissible frictional moment of bearings with the sliding contact surface combination steel/sinter bronze composite and steel/PTFE fabric are given in **Table 2**. The values for the clearance limits of bearings with the sliding contact surface combination steel/PTFE composite are listed in **Table 3**.

Table 1

Nominal diameter d, D		Inner ring				Outer ring			
		Δ_{dmp}		Δ_{Bs}		Δ_{Dmp}		Δ_{Cs}	
over	incl.	high	low	high	low	high	low	high	low
mm		μm		μm		μm		μm	
18	18	0	-8	0	-120	0	-8	0	-240
	30	0	-10	0	-120	0	-9	0	-240
30	30	0	-12	0	-120	0	-11	0	-240
	50	0	-15	0	-150	0	-13	0	-300
50	50	0	-20	0	-200	0	-15	0	-400
	120	0	-25	0	-250	0	-18	0	-500
80	80	0	-25	0	-250	0	-25	0	-500
	180	0	-30	0	-300	0	-30	0	-600
120	120	0	-35	0	-350	0	-35	0	-700
	315	0	-40	0	-400	0	-40	0	-800
150	150	0	-45	0	-450	0	-45	0	-900
	500	0	-50	0	-500	0	-50	0	-1 000
180	180	0	-75	0	-750	0	-75	0	-1 100
	800	0	-100	0	-1 000	0	-100	0	-1 200
250	250	0	-125	0	-1 250	0	-125	0	-1 300
	1 000	0	-125	0	-1 250	0	-125	0	-1 300
315	315	-	-	-	-	0	-160	0	-1 600
	400	-	-	-	-	0	-200	0	-2 000
400	400	-	-	-	-	0	-200	0	-2 000
	630	-	-	-	-	0	-200	0	-2 000
500	500	-	-	-	-	0	-200	0	-2 000
	800	-	-	-	-	0	-200	0	-2 000
630	630	-	-	-	-	0	-200	0	-2 000
	1 000	-	-	-	-	0	-200	0	-2 000
800	800	-	-	-	-	0	-200	0	-2 000
	1 250	-	-	-	-	0	-200	0	-2 000
1 000	1 000	-	-	-	-	0	-200	0	-2 000
	1 600	-	-	-	-	0	-200	0	-2 000
1 250	1 250	-	-	-	-	0	-200	0	-2 000
	2 000	-	-	-	-	0	-200	0	-2 000
1 600	1 600	-	-	-	-	0	-200	0	-2 000
	2 000	-	-	-	-	0	-200	0	-2 000

Tolerances of maintenance-free radial bearings

Permissible operating temperature range

The permissible operating temperature range of maintenance-free spherical plain bearings depends on the sliding contact surface combination and also on the polyester elastomer material of the seals (→ **Matrix 1**). However, if the load carrying capacity of the bearings is fully exploited the temperature range is narrowed. Under normal loads it is possible to operate at temperatures above the upper limit for brief periods.

Internal clearance and frictional moment of steel/sinter bronze composite and steel/PTFE fabric bearings

Table 2

Bore diameter		Series		GE .. TXA, TXE, TXGR, TXG3A, TXG3E	
d		GE .. C, CJ2		Internal clearance	Frictional moment
over	incl.	Internal clearance max	Frictional moment max	min	max
mm		µm	Nm	µm	
	12	28	0,15	–	50
12	17	35	0,25	–	50
17	20	35	0,25	–	50
	20	44	0,40	–	50
20	30	53	0,75	–	50
30	35	53	0,75	–	50
35	40	53	0,75	–	50
	40	53	0,75	–	50
40	45	53	0,75	–	50
45	50	53	0,75	–	50
50	60	53	0,75	–	50
	60	–	–	–	50
60	70	–	–	–	50
70	90	–	–	–	50
90	140	–	–	50	130
	140	–	–	50	140
140	180	–	–	80	190
180	300	–	–	80	190

Internal clearance for steel/PTFE composite bearings

Table 3

Bore diameter		Radial internal clearance			
d		Series GEP		Series GEC	
over	incl.	min	max	min	max
mm		µm			
	90	85	285	–	–
90	120	100	355	–	–
120	220	110	365	–	–
	240	110	380	–	–
240	280	135	415	–	–
280	300	135	490	135	600
300	360	135	490	135	630
	360	135	510	135	630
360	380	145	540	145	640
380	400	145	540	145	640
400	480	145	570	145	640
	480	160	610	160	670
480	500	160	640	160	670
500	600	170	670	170	690
600	630	170	670	170	760
	630	170	700	170	760
630	670	170	700	170	760
670	750	195	770	195	800
750	800	195	820	195	800
	800	–	–	220	820
800	950	–	–	220	820
950	1 000	–	–	220	820
1 000	1 250	–	–	220	820

Maintenance-free spherical plain bearings with sliding contact surface combination steel/sinter bronze composite
d 4 – 60 mm

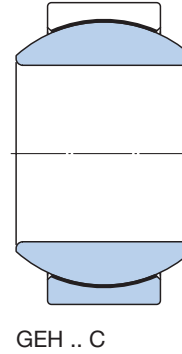
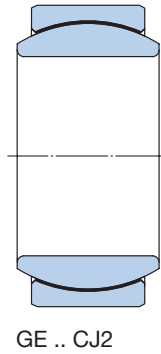
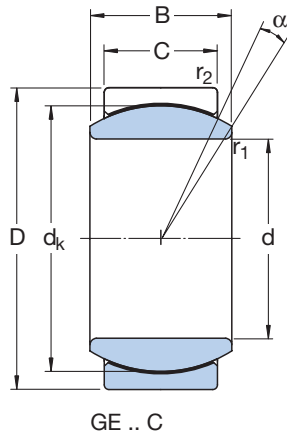

Principal dimensions				Angle of tilt ¹⁾ α	Basic load ratings		Mass	Designation
d	D	B	C		dynamic	static		
				degrees	C	C ₀		
mm					kN		kg	–
4	12	5	3	16	2,16	5,4	0,003	GE 4 C
6	14	6	4	13	3,6	9	0,004	GE 6 C
8	16	8	5	15	5,85	14,6	0,008	GE 8 C
10	19	9	6	12	8,65	21,6	0,012	GE 10 C
	22	12	7	18	11,4	28,5	0,020	GEH 10 C
12	22	10	7	10	11,4	28,5	0,017	GE 12 C
	26	15	9	18	18	45	0,030	GEH 12 C
15	26	12	9	8	18	45	0,032	GE 15 C
	30	16	10	16	22,4	56	0,050	GEH 15 C
17	30	14	10	10	22,4	56	0,050	GE 17 C
	35	20	12	19	31,5	78	0,090	GEH 17 C
20	35	16	12	9	31,5	78	0,065	GE 20 C
	42	25	16	17	51	127	0,16	GEH 20 C
25	42	20	16	7	51	127	0,12	GE 25 C
	47	28	18	17	65,5	166	0,20	GEH 25 C
30	47	22	18	6	65,5	166	0,16	GE 30 C
35	55	25	20	6	80	200	0,23	GE 35 CJ2
40	62	28	22	7	100	250	0,32	GE 40 CJ2
45	68	32	25	7	127	320	0,46	GE 45 CJ2
50	75	35	28	6	156	390	0,56	GE 50 CJ2
60	90	44	36	6	245	610	1,10	GE 60 CJ2

¹⁾ To fully utilize the angle of tilt, the shaft shoulder should not be made larger than $d_{a\max}$

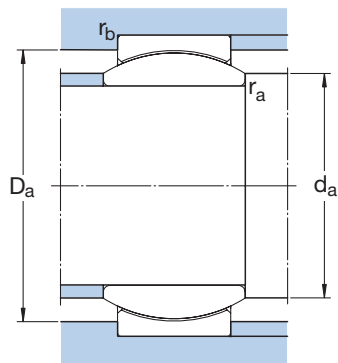

Dimensions

Abutment and fillet dimensions

d	d _k	r ₁ min	r ₂ min	d _a min	d _a max	D _a max	D _a min	r _a max	r _b max
mm									
4	8	0,3	0,3	5,4	6,2	10,7	7,6	0,3	0,3
6	10	0,3	0,3	7,4	8	12,7	9,5	0,3	0,3
8	13	0,3	0,3	9,4	10,2	14,6	12,3	0,3	0,3
10	16	0,3	0,3	11,5	13,2	17,6	15,2	0,3	0,3
	18	0,3	0,3	11,6	13,4	20,6	17,1	0,3	0,3
12	18	0,3	0,3	13,5	15	20,6	17,1	0,3	0,3
	22	0,3	0,3	13,7	16,1	24,5	20,9	0,3	0,3
15	22	0,3	0,3	16,6	18,4	24,5	20,9	0,3	0,3
	25	0,3	0,3	16,7	19,2	28,5	23,7	0,3	0,3
17	25	0,3	0,3	18,7	20,7	28,5	23,7	0,3	0,3
	29	0,3	0,3	18,9	21	33,4	27,6	0,3	0,3
20	29	0,3	0,3	21,8	24,2	33,4	27,6	0,3	0,3
	35,5	0,3	0,6	22,1	25,2	39,5	33,7	0,3	0,6
25	35,5	0,6	0,6	27,7	29,3	39,5	33,7	0,6	0,6
	40,7	0,6	0,6	27,9	29,5	44,4	38,7	0,6	0,6
30	40,7	0,6	0,6	32,8	34,2	44,4	38,7	0,6	0,6
35	47	0,6	1	37,9	39,8	51,4	44,7	0,6	1
40	53	0,6	1	42,9	45	58,3	50,4	0,6	1
45	60	0,6	1	48,7	50,8	64,2	57	0,6	1
50	66	0,6	1	53,9	56	71,1	62,7	0,6	1
60	80	1	1	65,4	66,8	85,8	76	1	1

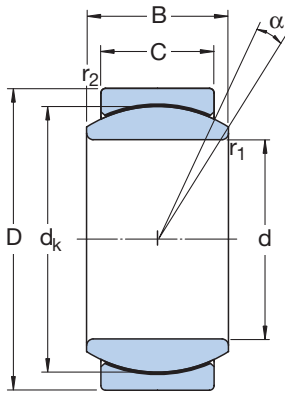

GE .. TX

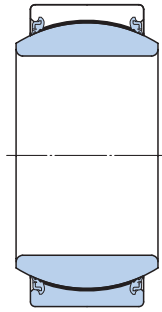

GE .. TX(G3)E-2LS

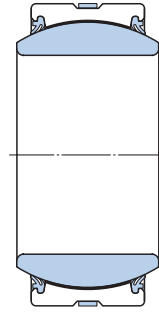

GE .. TX(G3)A-2LS(-2RS)

Principal dimensions				Angle of tilt ¹⁾	Basic load ratings		Mass	Designation
d	D	B	C		C	C ₀		
mm				degrees	kN		kg	-
12	22	10	7	10	30	50	0,017	GE 12 TXGR
15	26	12	9	8	47,5	80	0,032	GE 15 TXGR
17	30	14	10	10	60	100	0,050	GE 17 TXGR
20	35	16	12	9	83	140	0,065	GE 20 TXG3E
25	42	20	16	7	137	228	0,12	GE 25 TXE-2LS
	42	20	16	7	137	228	0,12	GE 25 TXG3E-2LS
30	47	22	18	6	176	290	0,16	GE 30 TXE-2LS
	47	22	18	6	176	290	0,16	GE 30 TXG3E-2LS
35	55	25	20	6	224	375	0,23	GE 35 TXE-2LS
	55	25	20	6	224	375	0,23	GE 35 TXG3E-2LS
40	62	28	22	6	280	465	0,32	GE 40 TXE-2LS
	62	28	22	6	280	465	0,32	GE 40 TXG3E-2LS
45	68	32	25	7	360	600	0,46	GE 45 TXE-2LS
	68	32	25	7	360	600	0,46	GE 45 TXG3E-2LS
50	75	35	28	6	440	735	0,56	GE 50 TXE-2LS
	75	35	28	6	440	735	0,56	GE 50 TXG3E-2LS
60	90	44	36	6	695	1 160	1,10	GE 60 TXE-2LS
	90	44	36	6	695	1 160	1,10	GE 60 TXG3E-2LS
70	105	49	40	6	880	1 460	1,55	GE 70 TXE-2LS
	105	49	40	6	880	1 460	1,55	GE 70 TXG3A-2LS
80	120	55	45	5	1 140	1 900	2,30	GE 80 TXE-2LS
	120	55	45	5	1 140	1 900	2,30	GE 80 TXG3A-2LS
90	130	60	50	5	1 370	2 320	2,75	GE 90 TXE-2LS
	130	60	50	5	1 370	2 320	2,75	GE 90 TXG3A-2LS
100	150	70	55	6	1 730	2 850	4,40	GE 100 TXA-2LS
	150	70	55	6	1 730	2 850	4,40	GE 100 TXG3A-2LS
110	160	70	55	6	1 860	3 100	4,80	GE 110 TXA-2LS
	160	70	55	6	1 860	3 100	4,80	GE 110 TXG3A-2LS
120	180	85	70	6	2 700	4 500	8,25	GE 120 TXA-2LS
	180	85	70	6	2 700	4 500	8,25	GE 120 TXG3A-2LS
140	210	90	70	7	3 000	5 000	11,0	GE 140 TXA-2RS
	210	90	70	7	3 000	5 000	11,0	GE 140 TXG3A-2RS

¹⁾ To fully utilize the angle of tilt, the shaft shoulder should not be made larger than d_{a max}

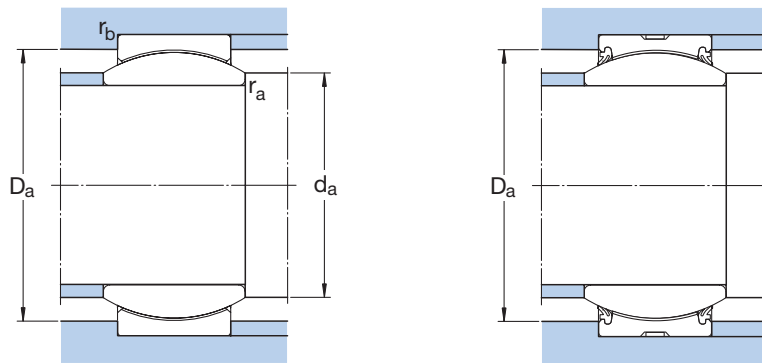

Dimensions

Abutment and fillet dimensions

d	d _k	r ₁ min	r ₂ min	d _a min	d _a max	D _a max	D _a min	r _a max	r _b max
mm									
12	18	0,3	0,3	13,8	15	20,4	17,1	0,3	0,3
15	22	0,3	0,3	16,9	18,4	24,3	20,9	0,3	0,3
17	25	0,3	0,3	19	20,7	28,3	23,7	0,3	0,3
20	29	0,3	0,3	22,1	24,2	33,2	27,6	0,3	0,3
25	35,5	0,6	0,6	28,2	29,3	39,2	36,9	0,6	0,6
	35,5	0,6	0,6	28,2	29,3	39,2	36,9	0,6	0,6
30	40,7	0,6	0,6	33,3	34,2	44	41,3	0,6	0,6
	40,7	0,6	0,6	33,3	34,2	44	41,3	0,6	0,6
35	47	0,6	1	38,5	39,8	51	48,5	0,6	1
	47	0,6	1	38,5	39,8	51	48,5	0,6	1
40	53	0,6	1	43,5	45	57,5	54,5	0,6	1
	53	0,6	1	43,5	45	57,5	54,5	0,6	1
45	60	0,6	1	49,5	50,8	63,5	61	0,6	1
	60	0,6	1	49,5	50,8	63,5	61	0,6	1
50	66	0,6	1	54,5	56	70,5	66,5	0,6	1
	66	0,6	1	54,5	56	70,5	66,5	0,6	1
60	80	1	1	66,5	66,8	84	80	1	1
	80	1	1	66,5	66,8	84	80	1	1
70	92	1	1	76,5	77,9	99	92	1	1
	92	1	1	76,5	77,9	99	92	1	1
80	105	1	1	87	89,4	113	105	1	1
	105	1	1	87	89,4	113	105	1	1
90	115	1	1	97,5	98,1	123	113	1	1
	115	1	1	97,5	98,1	123	113	1	1
100	130	1	1	108	109,5	144	131	1	1
	130	1	1	108	109,5	144	131	1	1
110	140	1	1	118	121	153	141,5	1	1
	140	1	1	118	121	153	141,5	1	1
120	160	1	1	130	135,5	172	157,5	1	1
	160	1	1	130	135,5	172	157,5	1	1
140	180	1	1	149	155,5	202	180	1	1
	180	1	1	149	155,5	202	180	1	1

Maintenance-free spherical plain bearings with sliding contact surface combination steel/PTFE fabric
d 160 – 300 mm

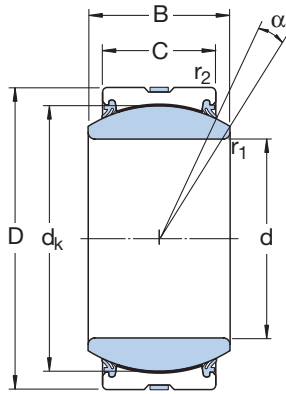

Principal dimensions				Angle of tilt ¹⁾	Basic load ratings		Mass	Designation
d	D	B	C	α	dynamic	static		
				degrees	C	C ₀	kg	–
160	230	105	80	8	3 800	6 400	14,0	GE 160 TXA-2RS
	230	105	80	8	3 800	6 400	14,0	GE 160 TXG3A-2RS
180	260	105	80	6	4 300	7 200	18,5	GE 180 TXA-2RS
	260	105	80	6	4 300	7 200	18,5	GE 180 TXG3A-2RS
200	290	130	100	7	6 000	10 000	28,0	GE 200 TXA-2RS
	290	130	100	7	6 000	10 000	28,0	GE 200 TXG3A-2RS
220	320	135	100	8	6 550	11 000	35,5	GE 220 TXA-2RS
240	340	140	100	8	7 200	12 000	40,0	GE 240 TXA-2RS
260	370	150	110	7	8 650	14 300	51,5	GE 260 TXA-2RS
280	400	155	120	6	10 000	16 600	65,0	GE 280 TXA-2RS
300	430	165	120	7	10 800	18 000	78,5	GE 300 TXA-2RS

¹⁾ To fully utilize the angle of tilt, the shaft shoulder should not be made larger than $d_{a \max}$

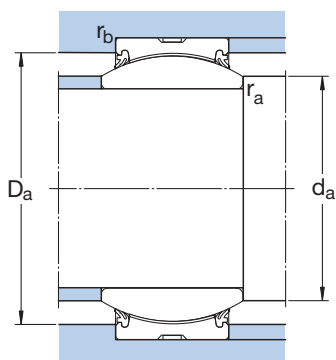

Dimensions

Abutment and fillet dimensions

d	d _k	r ₁ min	r ₂ min	d _a min	d _a max	D _a max	D _a min	r _a max	r _b max
mm	mm								
160	200	1	1	170	170	222	197	1	1
	200	1	1	170	170	222	197	1	1
180	225	1,1	1,1	191	199	250	224,5	1	1
	225	1,1	1,1	191	199	250	224,5	1	1
200	250	1,1	1,1	213	213,5	279	244,5	1	1
	250	1,1	1,1	213	213,5	279	244,5	1	1
220	275	1,1	1,1	233	239,5	309	271	1	1
240	300	1,1	1,1	253	265	329	298	1	1
260	325	1,1	1,1	273	288	359	321,5	1	1
280	350	1,1	1,1	294	313,5	388	344,5	1	1
300	375	1,1	1,1	314	336,5	418	371	1	1

Maintenance-free spherical plain bearings with sliding contact surface combination steel/PTFE composite
d 100 – 480 mm

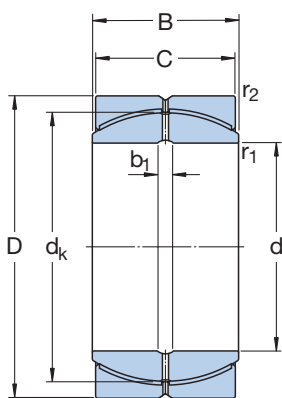

GEP .. FS

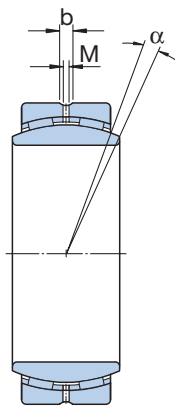

GEC .. FSA

Principal dimensions				Angle of tilt ¹⁾	Basic load ratings		Mass	Designation
d	D	B	C	α	C	C ₀		
mm				degrees	kN		kg	-
100	150	71	67	2	600	900	4,51	GEP 100 FS
110	160	78	74	2	720	1 080	5,35	GEP 110 FS
120	180	85	80	2	850	1 270	7,96	GEP 120 FS
140	210	100	95	2	1 200	1 800	13,0	GEP 140 FS
160	230	115	109	2	1 600	2 400	16,6	GEP 160 FS
180	260	128	122	2	2 080	3 100	24,4	GEP 180 FS
200	290	140	134	2	2 450	3 650	33,5	GEP 200 FS
220	320	155	148	2	3 050	4 550	45,8	GEP 220 FS
240	340	170	162	2	3 550	5 400	53,7	GEP 240 FS
260	370	185	175	2	4 250	6 400	69,5	GEP 260 FS
280	400	200	190	2	5 000	7 500	89,5	GEP 280 FS
300	430	212	200	2	5 600	8 300	110	GEP 300 FS
320	440	160	135	4	2 800	4 150	73,0	GEC 320 FSA
	460	230	218	2	6 400	9 650	135	GEP 320 FS
340	460	160	135	3	2 900	4 400	77,0	GEC 340 FSA
	480	243	230	2	7 100	10 800	150	GEP 340 FS
360	480	160	135	3	3 100	4 650	80,0	GEC 360 FSA
	520	258	243	2	8 150	12 200	200	GEP 360 FS
380	520	190	160	4	3 900	5 850	120	GEC 380 FSA
	540	272	258	2	9 150	13 700	220	GEP 380 FS
400	540	190	160	3	4 050	6 100	125	GEC 400 FSA
	580	280	265	2	9 650	14 600	275	GEP 400 FS
420	560	190	160	3	4 250	6 400	130	GEC 420 FSA
	600	300	280	2	10 600	16 000	300	GEP 420 FS
440	600	218	185	3	5 200	7 800	180	GEC 440 FSA
	630	315	300	2	12 200	18 600	360	GEP 440 FS
460	620	218	185	3	5 400	8 150	190	GEC 460 FSA
	650	325	308	2	12 900	19 600	380	GEP 460 FS
480	650	230	195	3	6 000	9 000	220	GEC 480 FSA
	680	340	320	2	14 300	21 200	435	GEP 480 FS

¹⁾ To fully utilize the angle of tilt, the shaft shoulder should not be made larger than $d_{a \max}$

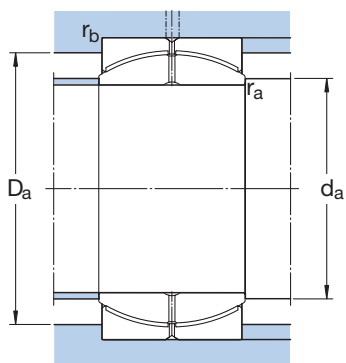

Dimensions

Abutment and fillet dimensions

d	d _k	b	b ₁	M	r ₁ min	r ₂ min	d _a min	d _a max	D _a max	D _a min	r _a max	r _b max
mm							mm					
100	135	7,5	7,5	4	1	1	106,7	114,8	141,9	125,6	1	1
110	145	7,5	7,5	4	1	1	117	122	151	135	1	1
120	160	7,5	7,5	4	1	1	127,5	135,5	171	149	1	1
140	185	7,5	7,5	4	1	1	148	155,5	200	172,5	1	1
160	210	7,5	7,5	4	1	1	169	175,5	218,5	195,5	1	1
180	240	7,5	7,5	4	1,1	1,1	191	203	246,5	223,5	1	1
200	260	11,5	11,5	5	1,1	1,1	211	219	276	242	1	1
220	290	13,5	13,5	6	1,1	1,1	232	245	304,5	270	1	1
240	310	13,5	13,5	6	1,1	1,1	252,5	259	323,5	288,5	1	1
260	340	15,5	15,5	7	1,1	1,1	273,5	285	352,5	316,5	1	1
280	370	15,5	15,5	7	1,1	1,1	294	311	381,5	344,5	1	1
300	390	15,5	15,5	7	1,1	1,1	314,5	327	411	363	1	1
320	380	21	–	8	1,1	3	327	344	427	381	1	3
	414	21	21	8	1,1	3	335	344	434	385	1	3
340	400	21	–	8	1,1	3	347	366	447	401	1	3
	434	21	21	8	1,1	3	356	359	453	404	1	3
360	420	21	–	8	1,1	3	367	388	467	421	1	3
	474	21	21	8	1,1	4	377	397	490	441	1	4
380	450	21	–	8	1,5	4	389	407	505	451	1,5	4
	494	21	21	8	1,5	4	398	412	508	460	1,5	4
400	470	21	–	8	1,5	4	409	429	525	471	1,5	4
	514	21	21	8	1,5	4	418	431	549	478	1,5	4
420	490	21	–	8	1,5	4	429	451	545	491	1,5	4
	534	21	21	8	1,5	4	439	441	568	497	1,5	4
440	520	27	–	10	1,5	4	449	472	584	521	1,5	4
	574	27	27	10	1,5	4	460	479	596	534	1,5	4
460	540	27	–	10	1,5	4	469	494	604	541	1,5	4
	593	27	27	10	1,5	5	481	496	612	552	1,5	5
480	565	27	–	10	2	5	491	516	631	566	2	5
	623	27	27	10	2	5	503	522	641	580	2	5

Maintenance-free spherical plain bearings with sliding contact surface combination steel/PTFE composite
d 500 – 1 250 mm

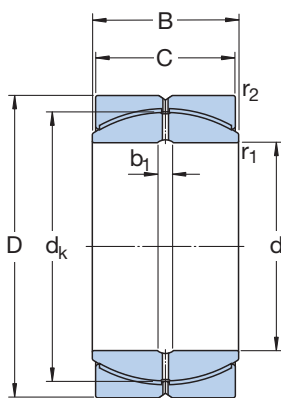

GEP .. FS

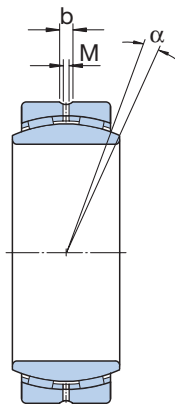

GEC .. FSA

Principal dimensions

Angle of tilt¹⁾

Basic load ratings
dynamic static

Mass

Designation

d	D	B	C	α	C	C ₀	Mass	Designation
				degrees	kN		kg	–
500	670	230	195	3	6 200	9 300	230	GEC 500 FSA GEP 500 FS
	710	355	335	2	15 300	23 200	500	
530	710	243	205	3	6 950	10 400	270	GEC 530 FSA GEP 530 FS
	750	375	355	2	17 000	25 500	585	
560	750	258	215	4	7 650	11 400	320	GEC 560 FSA GEP 560 FS
	800	400	380	2	19 600	29 000	730	
600	800	272	230	3	8 800	13 200	385	GEC 600 FSA GEP 600 FS
	850	425	400	2	22 000	33 500	860	
630	850	300	260	3	10 400	15 600	495	GEC 630 FSA GEP 630 FS
	900	450	425	2	24 500	37 500	1 040	
670	900	308	260	3	11 000	16 600	560	GEC 670 FSA GEP 670 FS
	950	475	450	2	27 500	41 500	1 210	
710	950	325	275	3	12 500	18 600	655	GEC 710 FSA GEP 710 FS
	1 000	500	475	2	31 000	46 500	1 400	
750	1 000	335	280	3	13 400	20 000	735	GEC 750 FSA GEP 750 FS
	1 060	530	500	2	34 500	52 000	1 670	
800	1 060	355	300	3	15 300	22 800	865	GEC 800 FSA GEP 800 FS
	1 120	565	530	2	39 000	58 500	1 940	
850	1 120	365	310	3	16 600	25 000	980	GEC 850 FSA GEP 850 FS
	1 220	600	565	2	45 000	67 000	2 600	
900	1 180	375	320	3	18 300	27 500	1 100	GEC 900 FSA GEP 900 FS
	1 250	635	600	2	49 000	73 500	2 690	
950	1 250	400	340	3	20 400	30 500	1 350	GEC 950 FSA GEP 950 FS
	1 360	670	635	2	56 000	85 000	3 620	
1 000	1 320	438	370	3	23 200	35 500	1 650	GEC 1000 FSA GEP 1000 FS
	1 450	710	670	2	63 000	95 000	4 470	
1 060	1 400	462	390	3	26 500	40 000	1 950	GEC 1060 FSA
1 120	1 460	462	390	3	28 000	41 500	2 050	GEC 1120 FSA
1 180	1 540	488	410	3	31 000	46 500	2 400	GEC 1180 FSA
1 250	1 630	515	435	3	34 500	52 000	2 850	GEC 1250 FSA

¹⁾ To fully utilize the angle of tilt, the shaft shoulder should not be made larger than $d_{a \max}$

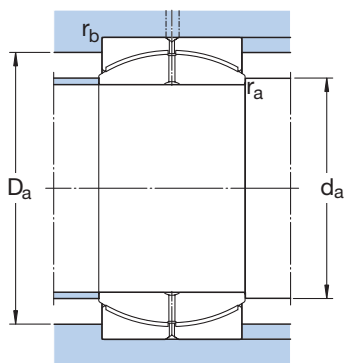

Dimensions

Abutment and fillet dimensions

d	d _k	b	b ₁	M	r ₁ min	r ₂ min	d _a min	d _a max	D _a max	D _a min	r _a max	r _b max
mm							mm					
500	585	27	–	10	2	5	511	537	651	586	2	5
	643	27	27	10	2	5	523	536	670	598	2	5
530	620	27	–	10	2	5	541	570	691	621	2	5
	673	27	27	10	2	5	554	558	709	626	2	5
560	655	27	–	10	2	5	571	602	731	656	2	5
	723	27	27	10	2	5	585	602	758	673	2	5
600	700	27	–	10	2	5	611	645	781	701	2	5
	773	27	27	10	2	6	627	645	801	719	2	6
630	740	35	–	13	3	6	645	676	827	741	3	6
	813	35	35	13	3	6	661	677	850	757	3	6
670	785	35	–	13	3	6	685	722	877	786	3	6
	862	35	35	13	3	6	702	719	898	802	3	6
710	830	35	–	13	3	6	725	763	926	831	3	6
	912	35	35	13	3	6	743	762	946	849	3	6
750	875	35	–	13	3	6	766	808	976	876	3	6
	972	35	35	13	3	6	784	814	1 005	904	3	6
800	930	35	–	13	3	6	816	859	1 036	931	3	6
	1 022	35	35	13	3	6	836	851	1 062	951	3	6
850	985	35	–	13	3	6	866	914	1 096	986	3	6
	1 112	35	35	13	3	7,5	888	936	1 156	1 035	3	7,5
900	1 040	35	–	13	3	6	916	970	1 156	1 041	3	6
	1 142	35	35	13	3	7,5	938	949	1 183	1 063	3	7,5
950	1 100	40	–	15	4	7,5	968	1 024	1 221	1 101	4	7,5
	1 242	40	40	15	4	7,5	993	1 045	1 290	1 156	4	7,5
1 000	1 160	40	–	15	4	7,5	1 019	1 074	1 290	1 161	4	7,5
	1 312	40	40	15	4	7,5	1 045	1 103	1 378	1 221	4	7,5
1 060	1 240	40	–	15	4	7,5	1 079	1 150	1 370	1 241	4	7,5
1 120	1 310	40	–	15	4	7,5	1 139	1 225	1 430	1 311	4	7,5
1 180	1 380	40	–	15	4	7,5	1 199	1 290	1 510	1 381	4	7,5
1 250	1 460	40	–	15	4	7,5	1 270	1 366	1 600	1 461	4	7,5

Angular contact spherical plain bearings

The sphered sliding contact surfaces of angular contact spherical plain bearings are inclined at an angle to the bearing axis (→ **fig 1**). Consequently, the bearings are particularly suitable for the accommodation of combined (radial and axial) loads. Singly mounted angular contact bearings can only support axial loads acting in one direction. The bearings are of separable design, e.g. the rings can be mounted separately.



Dimensions

The boundary dimensions of SKF angular contact spherical plain bearings conform to ISO 12240-2:1998.

Tolerances

SKF angular contact spherical plain bearings are made to the tolerances specified in **Table 1**. The tolerances conform to ISO 12240-2:1998.

The symbols used in the tolerance table are explained in the following.

- d nominal bore diameter
- Δ_{dmp} deviation of the mean bore diameter from the nominal
- D nominal outside diameter
- Δ_{Dmp} deviation of the mean outside diameter from the nominal
- Δ_{Bs} deviation of single inner ring width from the nominal
- Δ_{Cs} deviation of single outer ring width from the nominal
- Δ_{Ts} deviation of single bearing width (abutment width) from the nominal

Table 1

Nominal diameter d, D		Inner ring				Outer ring				Total width	
		Δ_{dmp}		Δ_{Bs}		Δ_{Dmp}		Δ_{Cs}		$\Delta_{Ts}^{1)}$	
over	incl.	high	low	high	low	high	low	high	low	high	low
mm		μm		μm		μm		μm		μm	
18	50	0	-12	0	-240	0	-14	0	-240	+250	-400
50	80	0	-15	0	-300	0	-16	0	-300	+250	-500
80	120	0	-20	0	-400	0	-18	0	-400	+250	-600
120	150	-	-	-	-	0	-20	0	-500	-	-
150	180	-	-	-	-	0	-25	0	-500	-	-

¹⁾ The width tolerance is related to d

Tolerances for angular contact spherical plain bearings

Load line through an angular contact spherical plain bearing

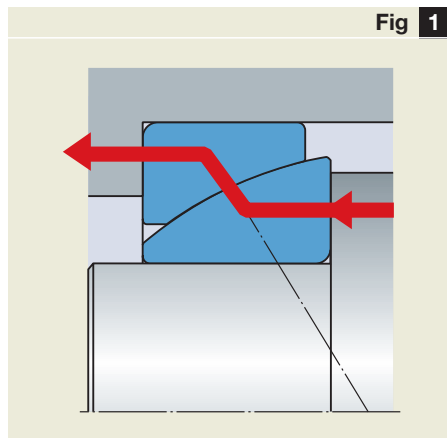

Fig 1

Radial internal clearance, preload

Internal clearance in a single angular contact spherical plain bearing is only obtained after mounting and is dependent on adjustment against a second bearing, which provides axial location in the opposite direction.

Angular contact spherical plain bearings are generally mounted in pairs in a back-to-back or face-to-face arrangement; the bearings are adjusted against each other by axially displacing one bearing ring until a specific bearing load of 10 N/mm² is obtained. The preload prevents some of the elastic and plastic deformations, which would occur under load and after a short period of operation. When adjusting bearings for the first time in a new arrangement, the specific bearing load of 10 N/mm² is achieved when the frictional moment and the axial preload force lie in the ranges specified in **Table 2**.

Materials

The inner and outer rings of SKF angular contact spherical plain bearings are made of through hardened and ground steel. The sliding surface of the inner ring is hard chromium plated and coated with a lithium base grease. The sliding layer of glass fibre reinforced plastic containing PTFE additives is injection moulded in the outer ring.

Permissible operating temperature range

Spherical plain bearings with the sliding contact surface combination steel/PTFE composite can be used in the temperature range of -40 to +75 °C, although brief periods of operation up to +110 °C are permitted. However, the load carrying capacity of the bearings will be reduced at temperatures above +50 °C.

Bearing	Frictional moment for 10 N/mm ²		Axial preload force for 10 N/mm ²
	min	max	
–	Nm		N
GAC 25 F	7	9	5 600
GAC 30 F	12	14	7 500
GAC 35 F	16	19	9 300
GAC 40 F	21	25	10 600
GAC 45 F	26	32	13 600
GAC 50 F	31	38	12 900
GAC 60 F	51	62	17 800
GAC 70 F	76	92	21 000
GAC 80 F	105	126	30 000
GAC 90 F	153	184	41 700
GAC 100 F	180	216	39 500
GAC 110 F	273	328	54 500
GAC 120 F	317	380	69 500

Frictional moment and axial preload force

Angular contact spherical plain bearings

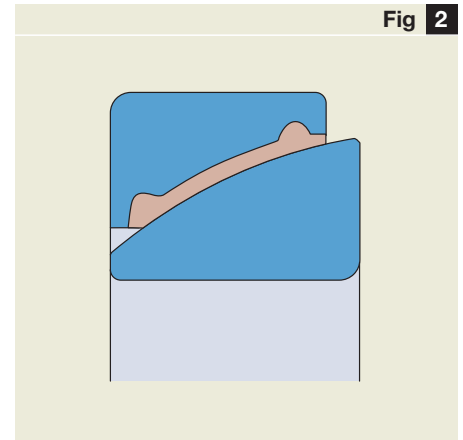

Standard angular contact spherical plain bearing

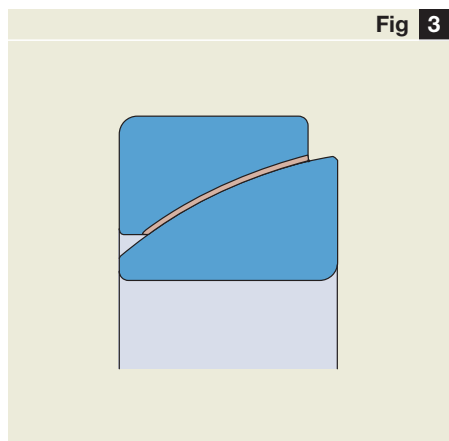

Maintenance-free bearing, sliding contact surface combination steel/PTFE fabric

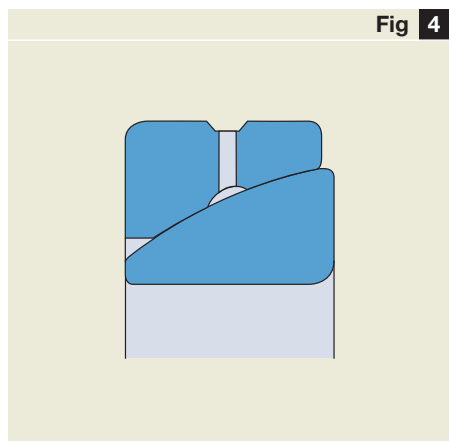

Steel-on-steel bearing

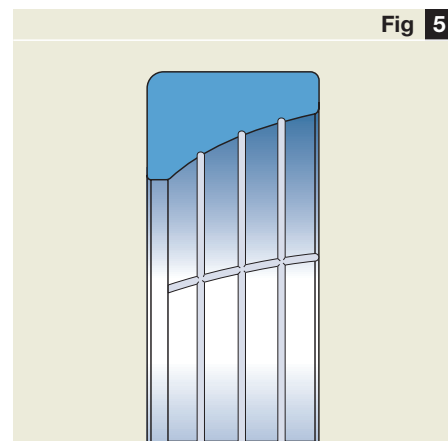

Steel-on-steel bearing with "waffle" grooves

Special designs

Special operating conditions may call for angular contact spherical plain bearings with sliding contact surface combinations steel-on-steel or steel/PTFE fabric and, consequently, such bearings are also produced by SKF.

Bearings with sliding contact surface combination steel/PTFE fabric (→ **fig 3**) should be used when maintenance-free operation is specified and where the bearing arrangement is such that the presence of any lubricant is not permitted.

Steel-on-steel bearings (→ **fig 4**) are preferred where operating temperatures, loads or load frequencies are high or where shock loads occur. To ensure correct operation, steel-on-steel bearings must be provided with an adequate supply of lubricant. Depending on the lubricant the sliding surface of the outer ring may be equipped with various types of lubrication grooves (→ **figs 5** and **6**).

Inch-size steel-on-steel angular contact spherical plain bearings are also available to order.

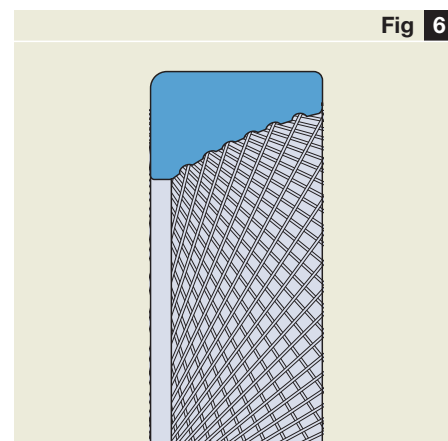

Steel-on-steel bearing with "diamond thread" grooves

Maintenance-free angular contact spherical plain bearings with sliding contact surface combination steel/PTFE composite
d 25 – 120 mm

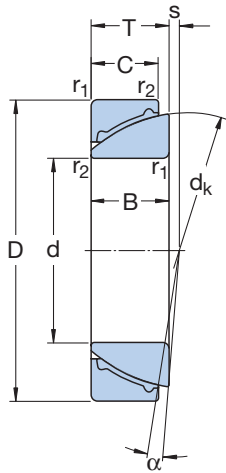

Principal dimensions			Angle of tilt	Basic load ratings		Mass	Designation
d	D	T	α	dynamic	static		
				C	C ₀		

mm			degrees	kN		kg	–
----	--	--	---------	----	--	----	---

25	47	15	3,5	21,6	34,5	0,14	GAC 25 F
30	55	17	3,5	27	43	0,21	GAC 30 F
35	62	18	3,5	32,5	52	0,27	GAC 35 F
40	68	19	3,5	39	62	0,33	GAC 40 F
45	75	20	3	45,5	73,5	0,42	GAC 45 F
50	80	20	3	53	85	0,46	GAC 50 F
60	95	23	3	69,5	112	0,73	GAC 60 F
70	110	25	2,5	88	143	1,05	GAC 70 F
80	125	29	2,5	110	176	1,55	GAC 80 F
90	140	32	2,5	134	216	2,10	GAC 90 F
100	150	32	2	170	270	2,35	GAC 100 F
110	170	38	2	200	320	3,70	GAC 110 F
120	180	38	1,5	240	380	4,00	GAC 120 F

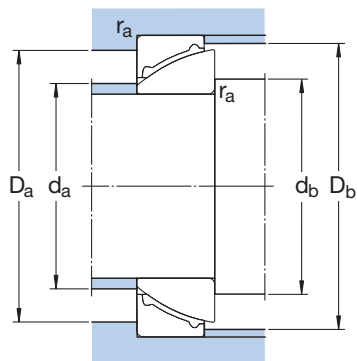

Dimensions

Abutment and fillet dimensions

d	d _k	B	C	r ₁ min	r ₂ min	s	d _a max	d _b max	D _a min	D _b min	r _a max
mm							mm				
25	42	15	14	0,6	0,3	0,6	29	39	34	43	0,6
30	49,5	17	15	1	0,3	1,3	35	45	39	50,5	1
35	55,5	18	16	1	0,3	2,1	40	50	45	56,5	1
40	62	19	17	1	0,3	2,8	45	54	50	63	1
45	68,5	20	18	1	0,3	3,5	51	60	55	69	1
50	74	20	19	1	0,3	4,3	56	67	60	74,5	1
60	88,5	23	21	1,5	0,6	5,7	68	77	70	90	1,5
70	102	25	23	1,5	0,6	7,2	78	92	85	103	1,5
80	115	29	25,5	1,5	0,6	8,6	88	104	95	116	1,5
90	128,5	32	28	2	0,6	10,1	101	118	105	129	2
100	141	32	31	2	0,6	11,6	112	128	120	141	2
110	155	38	34	2,5	0,6	13	124	145	130	156	2,5
120	168	38	37	2,5	0,6	14,5	134	155	140	169	2,5

Spherical plain thrust bearings

Spherical plain thrust bearings have a sphered surface on the shaft washer and a hollow, correspondingly sphered surface in the housing washer (→ **fig 1**). They are primarily intended to carry axial loads but are also suitable for the accommodation of radial loads in addition to simultaneously acting axial loads. The radial load component of combined loads should not exceed 50 % of the simultaneously acting axial load. When radial loads are very heavy it may be advisable to combine thrust bearings with larger radial bearings of dimension series GE (→ **fig 2**).

Spherical plain thrust bearings are of separable design, e.g. the washers can be mounted separately.

Fig 1

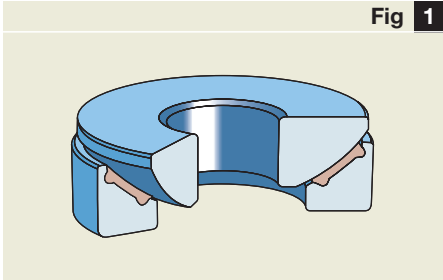

Standard spherical plain thrust bearing

Combination of radial and thrust bearings

Fig 2

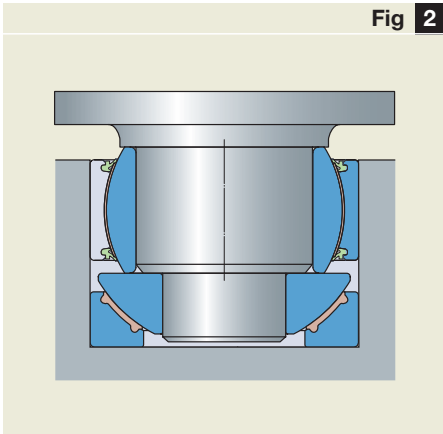

Dimensions

The principal dimensions of SKF spherical plain thrust bearings conform to ISO 12240-3:1998.

Tolerances

SKF spherical plain thrust bearings are made to the tolerances specified in **Table 1**. The tolerances conform to ISO 12240-3:1998.

The symbols used in the tolerance table are explained in the following.

- d nominal bore diameter
- Δ_{dmp} deviation of the mean bore diameter from the nominal
- D nominal outside diameter
- Δ_{Dmp} deviation of the mean outside diameter from the nominal
- Δ_{Bs} deviation of single shaft washer width from the nominal
- Δ_{Cs} deviation of single housing washer width from the nominal
- Δ_{Ts} deviation of single height of thrust bearing from the nominal

Materials

The shaft and housing washers of SKF spherical plain thrust bearings are made of through hardened and ground steel. The sliding surface of the shaft washer is hard chromium plated and coated with a lithium base grease. The sliding layer of glass fibre reinforced plastic containing PTFE additives is injection moulded in the housing washer.

Permissible operating temperature range

Spherical plain bearings with the sliding contact surface combination steel/PTFE composite can be used in the temperature range -40 to +75 °C, although brief periods of operation up to +110 °C are permitted. However, the load carrying capacity of the bearings will be reduced at temperatures above +50 °C.

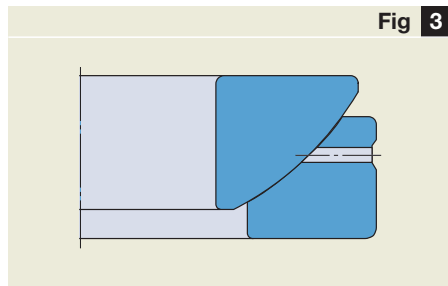

Steel-on-steel spherical plain thrust bearing with lubrication hole and groove

Special designs

Special operating conditions may call for spherical plain thrust bearings with the sliding contact surface combinations steel-on-steel or steel/PTFE fabric and consequently they are produced to order by SKF.

Steel-on-steel bearings (→ fig 3) are preferred where operating temperatures, loads or load frequencies are high or where shock loads occur.

Bearings with the sliding contact surface steel/PTFE fabric (→ fig 4) should be used when maintenance-free operation is specified and where the bearing arrangement is such that the presence of any lubricant is not permitted.

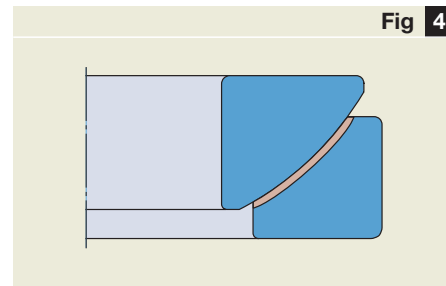

Maintenance-free thrust bearing with sliding contact surface combination steel/PTFE fabric

Tolerances of spherical plain thrust bearings

Table 1

Nominal diameter d, D		Shaft washer			Housing washer		Single height				
		Δ_{dmp}	Δ_{Bs}	Δ_{Dmp}	Δ_{Cs}	$\Delta_{Ts}^{1)}$					
over	incl.	high	low	high	low	high	low				
mm		μm		μm		μm					
-	18	0	-8	0	-240	-	-	+250	-400		
	30	0	-10	0	-240	-	-	+250	-400		
	50	0	-12	0	-240	0	-11	0	-240	+250	-400
	80	0	-15	0	-300	0	-13	0	-300	+250	-500
	120	0	-20	0	-400	0	-15	0	-400	+250	-600
	150	-	-	-	-	0	-18	0	-500	-	-
	180	-	-	-	-	0	-25	0	-500	-	-
	230	-	-	-	-	0	-30	0	-600	-	-

¹⁾ The width tolerance is related to d

Maintenance-free spherical plain thrust bearings with sliding contact surface combination steel/PTFE composite
 d 17 – 120 mm

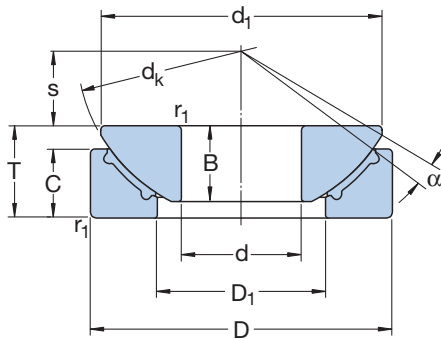

Principal dimensions			Angle of tilt	Basic load ratings		Mass	Designation
d	D	T	α	C	C_0		
mm			degrees	kN		kg	–
17	47	16	5	36,5	58,5	0,14	GX 17 F
20	55	20	5	46,5	73,5	0,25	GX 20 F
25	62	22,5	5	69,5	112	0,42	GX 25 F
30	75	26	5	95	153	0,61	GX 30 F
35	90	28	6	134	216	0,98	GX 35 F
40	105	32	6	173	275	1,50	GX 40 F
45	120	36,5	6	224	355	2,25	GX 45 F
50	130	42,5	6	275	440	3,15	GX 50 F
60	150	45	6	375	600	4,65	GX 60 F
70	160	50	5	475	750	5,40	GX 70 F
80	180	50	5	570	915	6,95	GX 80 F
100	210	59	5	735	1 180	11,0	GX 100 F
120	230	64	4	880	1 430	14,0	GX 120 F

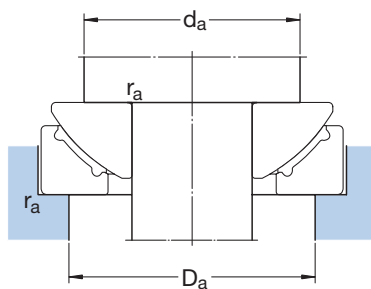

Dimensions

Abutment and fillet dimensions

d	d _k	d ₁	D ₁	B	C	r ₁ min	s	d _a min	D _a max	r _a max
mm								mm		
17	52	43,5	27	11,8	11,2	0,6	11	34	37	0,6
20	60	50	31	14,5	13,8	1	12,5	40	44	1
25	68	58,5	34,5	16,5	16,7	1	14	45	47	1
30	82	70	42	19	19	1	17,5	56	59	1
35	98	84	50,5	22	20,7	1	22	66	71	1
40	114	97	59	27	21,5	1	24,5	78	84	1
45	128	110	67	31	25,5	1	27,5	89	97	1
50	139	120	70	33	30,5	1	30	98	105	1
60	160	140	84	37	34	1	35	109	120	1
70	176	153	94,5	42	36,5	1	35	121	125	1
80	197	172	107,5	43,5	38	1	42,5	135	145	1
100	222	198	127	51	46	1	45	155	170	1
120	250	220	145	53,5	50	1	52,5	170	190	1

Rod ends requiring maintenance

Steel-on-steel rod ends

Steel-on-steel rod ends consist of a rod end housing and a normal steel-on-steel spherical plain bearing which is held in position axially in the housing. The rod ends are available with female thread (→ fig 1), male thread (→ fig 2) or with a welding shank (→ fig 3).

Fig 1



Rod end with female thread

Fig 2

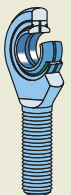

Rod end with male thread

Fig 3



Rod end with welding shank



Steel-on-steel bronze rod ends

Steel-on-bronze rod ends consist of a rod end housing and a steel-on-bronze spherical plain bearing having an outer ring made of bronze. The bearing is held in position by staking at both sides of the outer ring. These rod ends are available with female or male thread.

Dimensions

The dimensions of SKF rod ends are standardized and correspond to the standards listed in **Table 1**. Rod ends identified by designation suffix VZ019 have a male thread which deviates from the ISO standard but conforms to the CETOP¹⁾ Recommendation RP 103 P.

The female and male threads of SKF rod ends correspond to ISO 965-1:1998.

Tolerances

The tolerances to which SKF rod ends are made conform to ISO 12240-4:1998. The tolerances for the steel-on-steel rod end inner rings are given in **Table 2** and those for steel-on-bronze rod end inner rings are given in **Table 3**.

The symbols used in these tables are defined in the following.

d nominal bore diameter

Δ_{dmp} deviation of the mean bore diameter from the nominal

Δ_{Bs} deviation of single inner ring width from the nominal

Table 1

Series	Standards
SA(A) SI(A) SC	ISO 12240-4:1998
SCF SIJ	– ISO 8138:1991
SIR SIQG	– CETOP RP 88 H
SAKAC SIKAC SIKAC/VZ019	ISO 12240-4:1998 ISO 12240-4:1998 ISO 8139:1991, CETOP RP 103 P

Standards**Tolerances for steel-on-steel rod end inner rings**

Table 2

Bore diameter	Series SA(A), SI(A), SIJ, SIR, SC, SCF				Series SIQG			
	Δ_{dmp}		Δ_{Bs}		Δ_{dmp}		Δ_{Bs}	
over incl.	low	high	low	high	low	high	low	high
mm	μm		μm		μm		μm	
10 10 10 18 18 30	0	-8	0	-120	–	–	–	–
	0	-8	0	-120	+18	0	0	-180
	0	-10	0	-120	+21	0	0	-210
30 30 50 80 80 120	0	-12	0	-120	+25	0	0	-250
	0	-15	0	-150	+30	0	0	-300
	0	-20	0	-200	+35	0	0	-350
120 120 180 250	–	–	–	–	+40	0	0	-400
	–	–	–	–	+46	0	0	-460

Tolerances for steel-on-bronze rod end inner rings

Table 3

Bore diameter	Series SIKAC, SAKAC			
	Δ_{dmp}		Δ_{Bs}	
over incl.	high	low	high	low
mm	μm		μm	
6 6 6 10	+12	0	0	-120
	+15	0	0	-120
10 10 18 30	+18	0	0	-120
	+21	0	0	-120

¹⁾ CETOP = Comité Européen des Transmissions Oléohydrauliques et Pneumatiques (European Committee for Hydraulic and Pneumatic Transmissions)

Table 4

Steel-on-steel rod ends				Steel-on-bronze rod ends			
Bore diameter		Radial internal clearance		Bore diameter		Radial internal clearance	
d over	incl.	Normal min	max	d over	incl.	Normal min	max
mm		µm		mm		µm	
12	12 20	16 20	68 82	6	6 10	5 7	50 60
20	35 60	25 30	100 120	10	18 30	8 10	75 90
60	90	36	142				
90	140	42	165				
140	240	50	192				

Radial internal clearance**Radial internal clearance**

The steel-on-steel rod ends have radial internal clearance corresponding to the Normal clearance values quoted in ISO 12240-4:1998 which are given in Table 4.

Materials

The materials used for the manufacture of SKF rod ends requiring maintenance are listed in Table 5.

Details of the materials used for the steel-on-steel spherical plain bearings incorporated in SKF rod ends will be found under the heading "Materials" on page 61.

The bearings incorporated in the steel-on-bronze rod ends have an outer ring of tin bronze. The inner ring is of carbon chromium steel and is hardened, ground and polished.

Permissible operating temperature range

The operating temperature range for the rod ends requiring maintenance depends on the rod end, the bearing incorporated, the bearing seals and the grease used for lubrication. The actual limits are given in Table 6.

Rod end housing materials

Table 5

Series	Size	Material	Material No.
SA(A)	6 to 80	Heat treatable steel C45V zinc coated and chromatinized	1.0503
SI(A)	6 to 80	Heat treatable steel C45V zinc coated and chromatinized	1.0503
SC	25 to 80	Construction steel S 355 J2G3 (St 52-3 N)	1.0570
SCF	20 to 80	Construction steel S 355 J2G3 (St 52-3 N)	1.0570
SIQG	12 to 50	Heat treatable steel C45N	1.0503
	63 to 200	Spheroidal graphite cast iron GGG40	–
SIJ	12 to 50	Heat treatable steel C45N	1.0503
	60 to 100	Spheroidal graphite cast iron GGG40	–
SIR	20 to 50	Heat treatable steel C45N	1.0503
	60 to 120	Spheroidal graphite cast iron GGG40	–
SAKAC	5 to 12	Automatic steel 9 SMnPb 28 K zinc coated and chromatinized	1.0718
	14 to 30	Heat treatable steel C35N zinc coated and chromatinized	1.0501
SIKAC	5 to 12	Automatic steel 9 SMnPb 28 K zinc coated and chromatinized	1.0718
	14 to 30	Heat treatable steel C35N zinc coated and chromatinized	1.0501

Note

The load carrying capacity of rod ends is reduced at temperatures above +100 °C. For temperatures below 0 °C, the fracture toughness of the rod end material must be taken into consideration.

Fatigue strength

In all applications where a rod end is subjected to loads which vary in magnitude or are alternating, or where the failure of a rod end would be dangerous, it is advisable to check that the selected rod end has a suitable fatigue strength.

Relubrication facilities

All SKF rod ends requiring maintenance, with the exception of steel-on-steel rod ends of series SA .. E and SI .. E and the steel-on-bronze rod ends of size 5 are provided with a grease nipple or hole in the rod end housing. The type and design of the relubrication facilities in the rod end housing are shown in **Table 7**.

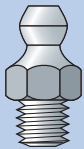

Table 6

Series	Permissible operating temperature range ¹⁾		Reduced load carrying capacity from
	from	incl.	
–	°C		°C
Steel-on-steel			
SA .. E(S)	–50	+300	+100
SA(A) .. ES-2RS	–30	+130	+100
SI .. E(S)	–50	+300	+100
SI(A) .. ES-2RS	–30	+130	+100
SIQG .. ES	–50	+300	+100
SIJ .. ES	–50	+300	+100
SIR .. ES	–50	+300	+100
SC .. ES	–50	+300	+100
SCF .. ES	–50	+300	+100
Steel-on-bronze			
SAKAC .. M	–30	+180	+100
SIKAC .. M(VZ019)	–30	+180	+100

¹⁾ NB. The permissible operating temperature range of the grease used should not be exceeded

Permissible operating temperature range**Relubrication facilities**

Table 7

Series	Size	Grease nipple to DIN/ISO	Design
SA .. ES SI .. ES SIJ .. ES	15 .. 20 15 .. 20 16 .. 20	Lubrication hole 2,5 mm diameter	
SA(A) .. ES-2RS SI(A) .. ES-2RS SIJ .. ES SIR .. ES SIQG .. ES SC .. ES SCF .. ES	25 .. 80 25 .. 80 25 .. 100 25 .. 120 12 .. 200 25 .. 80 20 .. 80	Lubrication nipple to DIN 71412:1987, Form A ISO 3799:1976	
SAKAC .. M SIKAC .. M	6 .. 30 6 .. 30	Lubrication nipple to DIN 3405:1986 Form D	

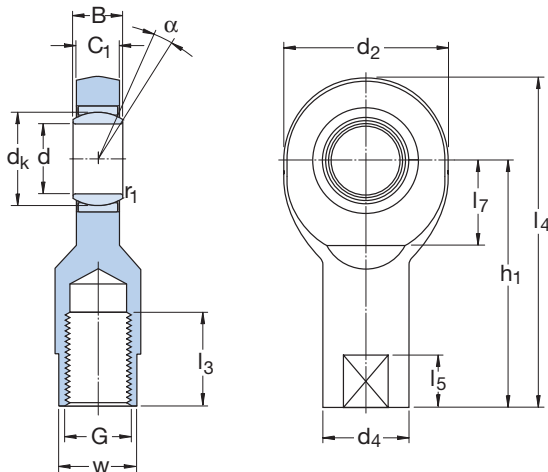

SI .. E

Principal dimensions						Angle of tilt	Basic load ratings dynamic static		Mass	Designations Rod end with right-hand thread	
d	d ₂ max	G 6H	B	C ₁ max	h ₁	α	C	C ₀			left-hand thread
mm						degrees	kN		kg	–	
6	22	M 6	6	4,5	30	13	3,4	8,15	0,023	SI 6 E	SIL 6 E
8	25	M 8	8	6,5	36	15	5,5	12,9	0,036	SI 8 E	SIL 8 E
10	30	M 10	9	7,5	43	12	8,15	19	0,065	SI 10 E	SIL 10 E
12	35	M 12	10	8,5	50	10	10,8	25,5	0,11	SI 12 E	SIL 12 E
15	41	M 14	12	10,5	61	8	17	37,5	0,18	SI 15 ES	SIL 15 ES
17	47	M 16	14	11,5	67	10	21,2	44	0,25	SI 17 ES	SIL 17 ES
20	54	M 20×1,5	16	13,5	77	9	30	57	0,36	SI 20 ES	SIL 20 ES
25	65	M 24×2	20	18	94	7	48	90	0,65	SI 25 ES	SIL 25 ES
30	75	M 30×2	22	20	110	6	62	116	1,00	SI 30 ES	SIL 30 ES
35	84	M 36×3	25	22	130	6	80	134	1,40	SI 35 ES-2RS	SIL 35 ES-2RS
40	94	M 39×3	28	24	142	6	100	166	2,20	SIA 40 ES-2RS	SILA 40 ES-2RS
	94	M 42×3	28	24	145	6	100	166	2,30	SI 40 ES-2RS	SIL 40 ES-2RS
45	104	M 42×3	32	28	145	7	127	224	2,90	SIA 45 ES-2RS	SILA 45 ES-2RS
	104	M 45×3	32	28	165	7	127	224	3,20	SI 45 ES-2RS	SIL 45 ES-2RS
50	114	M 45×3	35	31	160	6	156	270	4,10	SIA 50 ES-2RS	SILA 50 ES-2RS
	114	M 52×3	35	31	195	6	156	270	4,50	SI 50 ES-2RS	SIL 50 ES-2RS
60	137	M 52×3	44	39	175	6	245	400	6,30	SIA 60 ES-2RS	SILA 60 ES-2RS
	137	M 60×4	44	39	225	6	245	400	7,10	SI 60 ES-2RS	SIL 60 ES-2RS
70	162	M 56×4	49	43	200	6	315	530	9,50	SIA 70 ES-2RS	SILA 70 ES-2RS
	162	M 72×4	49	43	265	6	315	530	10,5	SI 70 ES-2RS	SIL 70 ES-2RS
80	182	M 64×4	55	48	230	5	400	655	15,0	SIA 80 ES-2RS	SILA 80 ES-2RS
	182	M 80×4	55	48	295	5	400	655	19,0	SI 80 ES-2RS	SIL 80 ES-2RS

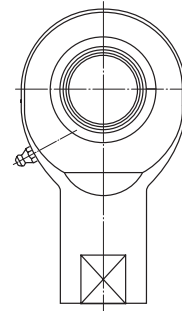
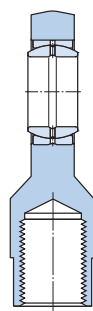
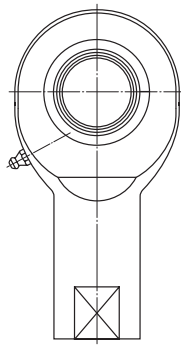
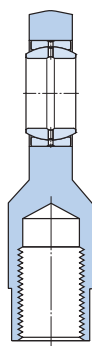

SI .. ES

SIA .. ES-2RS

Dimensions

d	dk	d4 ≈	l3 min	l4 max	l5 ≈	l7 min	r1 min	w h14
mm								
6	10	11	11	43	8	10	0,3	9
8	13	13	15	50	9	11	0,3	11
10	16	16	15	60	11	13	0,3	14
12	18	19	18	69	12	17	0,3	17
15	22	22	21	83	14	19	0,3	19
17	25	25	24	92	15	22	0,3	22
20	29	28	30	106	16	24	0,3	24
25	35,5	35	36	128	18	30	0,6	30
30	40,7	42	45	149	19	34	0,6	36
35	47	49	60	174	25	40	0,6	41
40	53	58	65	191	25	46	0,6	50
	53	58	65	194	25	46	0,6	50
45	60	65	65	199	30	50	0,6	55
	60	65	65	219	30	50	0,6	55
50	66	70	68	219	30	58	0,6	60
	66	70	68	254	30	58	0,6	60
60	80	82	70	246	35	73	1	70
	80	82	70	296	35	73	1	70
70	92	92	80	284	40	85	1	80
	92	92	80	349	40	85	1	80
80	105	105	85	324	45	98	1	90
	105	105	85	389	45	98	1	90

3.5

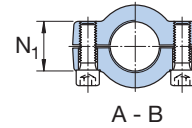
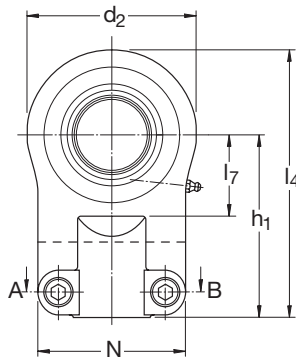
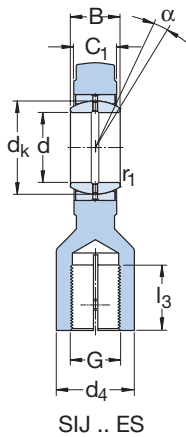

Principal dimensions						Angle of tilt	Basic load ratings		Mass	Designations	
d	d ₂ max	G 6H	B	C ₁ max	h ₁	α	C	C ₀		Rod end with right-hand thread	left-hand thread ¹⁾
mm						degrees	kN		kg	-	
12	40	M 10×1,25	10	8	42	3	10,8	21,2	0,14	SIJ 12 E	SILJ 12 E
	33	M 12×1,25	12	11	38	4	10,8	22	0,11	SIQG 12 ESA	SILQG 12 ESA
16	45	M 12×1,25	14	11	48	3	21,2	23,5	0,25	SIJ 16 ES	SILJ 16 ES
	41	M 14×1,5	16	15	44	4	17,6	32,5	0,21	SIQG 16 ES	SILQG 16 ES
20	55	M 14×1,5	16	13	58	3	30	51	0,40	SIJ 20 ES	SILJ 20 ES
	50	M 16×1,5	20	19	52	4	30	43	0,40	SIQG 20 ES	SILQG 20 ES
25	65	M 16×1,5	20	17	68	3	48	73,5	0,68	SIJ 25 ES	SILJ 25 ES
	58	M 16×1,5	20	23,5	50	7	48	52	0,49	SIR 25 ES	SILR 25 ES
	62	M 20×1,5	25	23	65	4	48	69,5	0,66	SIQG 25 ES	SILQG 25 ES
30	80	M 20×1,5	22	19	85	3	62	112	1,35	SIJ 30 ES	SILJ 30 ES
	66	M 22×1,5	22	28,5	60	6	62	78	0,77	SIR 30 ES	SILR 30 ES
32	76	M 27×2	32	29	80	4	65,5	100	1,20	SIQG 32 ES	SILQG 32 ES
35	80	M 28×1,5	25	30,5	70	6	80	118	1,20	SIR 35 ES	SILR 35 ES
40	100	M 27×2	28	23	105	3	100	146	2,40	SIJ 40 ES	SILJ 40 ES
	96	M 35×1,5	28	35,5	85	7	100	200	2,10	SIR 40 ES	SILR 40 ES
	97	M 33×2	40	34	97	4	100	176	2,00	SIQG 40 ES	SILQG 40 ES
50	122	M 33×2	35	30	130	3	156	216	3,80	SIJ 50 ES	SILJ 50 ES
	118	M 45×1,5	35	40,5	105	6	156	280	3,60	SIR 50 ES	SILR 50 ES
	118	M 42×2	50	42	120	4	156	270	3,50	SIQG 50 ES	SILQG 50 ES
60	160	M 42×2	44	38	150	3	245	405	8,50	SIJ 60 ES	SILJ 60 ES
	132	M 58×1,5	44	50,5	130	6	245	325	6,00	SIR 60 ES	SILR 60 ES
63	142	M 48×2	63	55	140	4	255	375	6,80	SIQG 63 ES	SILQG 63 ES
70	157	M 65×1,5	49	55,5	150	6	315	450	9,40	SIR 70 ES	SILR 70 ES
80	205	M 48×2	55	47	185	3	400	610	14,5	SIJ 80 ES	SILJ 80 ES
	179	M 80×2	55	60,5	170	6	400	560	13,0	SIR 80 ES	SILR 80 ES
	180	M 64×3	80	69	180	4	400	600	14,5	SIQG 80 ES	SILQG 80 ES
100	240	M 64×3	70	57	240	3	610	780	29,5	SIJ 100 ES	SILJ 100 ES
	233	M 110×2	70	70,5	235	7	610	950	30,0	SIR 100 ES	SILR 100 ES
	224	M 80×3	100	87	210	4	610	930	28,0	SIQG 100 ES	SILQG 100 ES
120	342	M 130×3	85	90,5	310	6	950	2 450	84,0	SIR 120 ES	SILR 120 ES
125	290	M 100×3	125	105	260	4	950	1 430	43,0	SIQG 125 ES	SILQG 125 ES
160	346	M 125×4	160	132	310	4	1 370	2 200	80,0	SIQG 160 ES	SILQG 160 ES
200	460	M 160×4	200	164	390	4	2 120	3 400	165	SIQG 200 ES	SILQG 200 ES

¹⁾ Please check availability of rod ends with left-hand thread

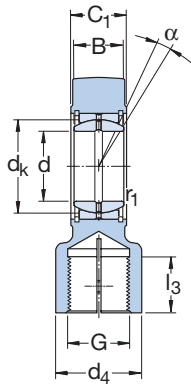

SIR .. ES

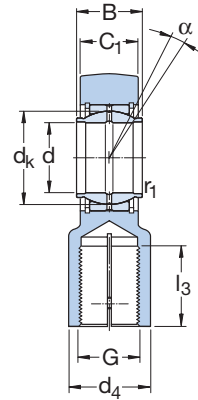
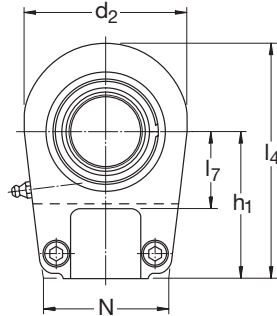

SIQG .. ES

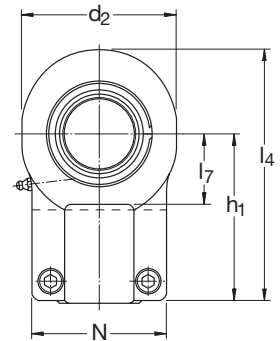

Dimensions

Cylinder screw
with internal hexagon
(ISO 4762:1998)
Size Tightening
torque

d	dk	d4 max	l3 min	l4 max	l7 min	N max	N1 max	r1 min	Size	Tightening torque
mm									-	Nm
12	18	17	15	62	16	40	13	0,3	M 6	9,5
	18	17	17	55,5	13	33	11	0,3	M 5	5,5
16	25	21	17	70,5	20	45	13	0,3	M 6	9,5
	23	22,5	19	64,5	18	41	17	0,3	M 6	9,5
20	29	25	19	85,5	25	55	17	0,3	M 8	23
	29	26,5	23	77,5	21	48	21	0,3	M 8	23
25	35,5	30	23	100,5	30	62	17	0,6	M 8	23
	35,5	26,5	17	81	27	46	22	0,6	M 8	23
	35,5	32	29	97	26	55	21	0,6	M 8	23
30	40,7	36	29	125	35	80	19	0,6	M 10	46
	40,7	34	23	95	29	50	27	0,6	M 8	23
32	43	40	37	120	31	67	24	0,6	M 10	46
35	47	42	29	113	37	66	29	0,6	M 10	46
40	53	45	37	155	45	90	23	0,6	M 10	46
	53	51	36	136	44	76	34	0,6	M 10	46
	53	49	46	147	40	81	28	0,6	M 10	46
50	66	55	46	192,5	58	105	30	0,6	M 12	79
	66	63,5	46	169	54	90	38	0,6	M 12	79
	66	60,5	57	181	49	97	34	0,6	M 12	79
60	80	68	57	230	68	134	38	1	M 16	195
	80	77,5	59	201	64	120	47	1	M 16	195
63	83	72,5	64	213	61	116	40	1	M 16	195
70	92	89	66	234	74	130	52	1	M 16	195
80	105	90	64	287,5	92	156	47	1	M 20	390
	105	109	81	267	79	160	57	1	M 20	390
	105	93	86	272	77	150	50	1	M 20	390
100	130	110	86	360	116	190	57	1	M 24	670
	130	142	111	362	103	200	67	1	M 24	670
	130	114	96	324	97	180	65	1	M 24	670
120	160	177	135	491	138	257	86	1	M 24	670
125	160	139	113	407	118	202	75	1	M 24	670
160	200	170	126	490	148	252	85	1	M 24	670
200	250	221	161	623	193	323	106	1,1	M 30	1 350

3.5

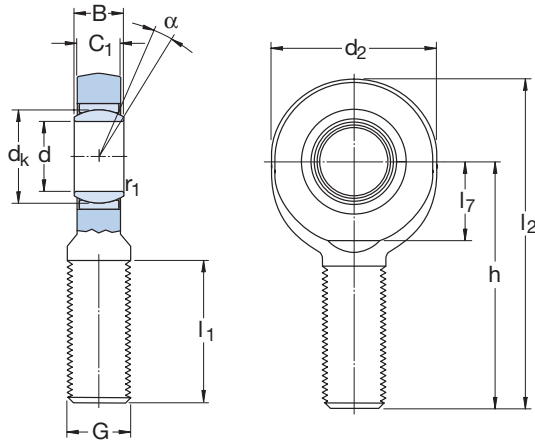

SA .. E

Principal dimensions						Angle of tilt	Basic load ratings		Mass	Designations	
d	d ₂ max	G 6g	B	C ₁ max	h	α	C	C ₀		Rod end with right-hand thread	left-hand thread
mm						degrees	kN		kg	-	
6	22	M 6	6	4,5	36	13	3,4	8,15	0,017	SA 6 E	SAL 6 E
8	25	M 8	8	6,5	42	15	5,5	12,9	0,029	SA 8 E	SAL 8 E
10	30	M 10	9	7,5	48	12	8,15	18,3	0,053	SA 10 E	SAL 10 E
12	35	M 12	10	8,5	54	10	10,8	24,5	0,078	SA 12 E	SAL 12 E
15	41	M 14	12	10,5	63	8	17	28	0,13	SA 15 ES	SAL 15 ES
17	47	M 16	14	11,5	69	10	21,2	31	0,19	SA 17 ES	SAL 17 ES
20	54	M 20×1,5	16	13,5	78	9	30	42,5	0,32	SA 20 ES	SAL 20 ES
25	65	M 24×2	20	18	94	7	48	78	0,53	SA 25 ES	SAL 25 ES
30	75	M 30×2	22	20	110	6	62	81,5	0,90	SA 30 ES	SAL 30 ES
35	84	M 36×3	25	22	130	6	80	110	1,30	SA 35 ES-2RS	SAL 35 ES-2RS
40	94	M 39×3	28	24	150	6	100	140	1,85	SAA 40 ES-2RS	SALA 40 ES-2RS
	94	M 42×3	28	24	145	6	100	140	1,90	SA 40 ES-2RS	SAL 40 ES-2RS
45	104	M 42×3	32	28	163	7	127	200	2,45	SAA 45 ES-2RS	SALA 45 ES-2RS
	104	M 45×3	32	28	165	7	127	200	2,55	SA 45 ES-2RS	SAL 45 ES-2RS
50	114	M 45×3	35	31	185	6	156	245	3,30	SAA 50 ES-2RS	SALA 50 ES-2RS
	114	M 52×3	35	31	195	6	156	245	3,90	SA 50 ES-2RS	SAL 50 ES-2RS
60	137	M 52×3	44	39	210	6	245	360	5,70	SAA 60 ES-2RS	SALA 60 ES-2RS
	137	M 60×4	44	39	225	6	245	360	6,25	SA 60 ES-2RS	SAL 60 ES-2RS
70	162	M 56×4	49	43	235	6	315	490	7,90	SAA 70 ES-2RS	SALA 70 ES-2RS
	162	M 72×4	49	43	265	6	315	490	10,0	SA 70 ES-2RS	SAL 70 ES-2RS
80	182	M 64×4	55	48	270	5	400	585	12,0	SAA 80 ES-2RS	SALA 80 ES-2RS
	182	M 80×4	55	48	295	5	400	585	14,5	SA 80 ES-2RS	SAL 80 ES-2RS

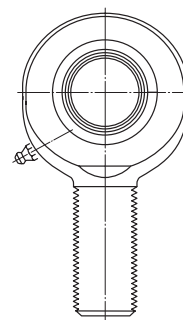
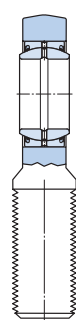
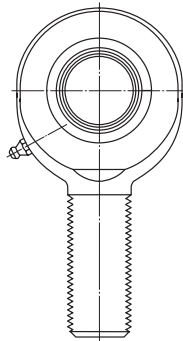
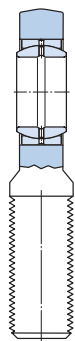

SA .. ES

SAA .. ES-2RS

Dimensions

d	d _k	l ₁ min	l ₂ max	l ₇ min	r ₁ min
mm					
6	10	16	49	10	0,3
8	13	21	56	11	0,3
10	16	26	65	13	0,3
12	18	28	73	17	0,3
15	22	34	85	19	0,3
17	25	36	94	22	0,3
20	29	43	107	24	0,3
25	35,5	53	128	30	0,6
30	40,7	65	149	34	0,6
35	47	82	174	40	0,6
40	53	86	199	46	0,6
	53	90	194	46	0,6
45	60	92	217	50	0,6
	60	95	219	50	0,6
50	66	104	244	58	0,6
	66	110	254	58	0,6
60	80	115	281	73	1
	80	120	296	73	1
70	92	125	319	85	1
	92	132	349	85	1
80	105	140	364	98	1
	105	147	389	98	1

3.5

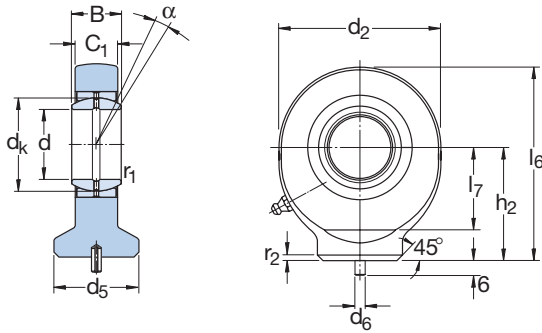

Principal dimensions

Angle of tilt

Basic load ratings
dynamic static

Mass

Designation

d	d ₂ max	B	C ₁ max	h ₂	α	C	C ₀		
mm					degrees	kN		kg	-
20	54	16	13,5	38	9	30	46,5	0,20	SC 20 ES
25	65	20	18	45	7	48	73,5	0,45	SC 25 ES
30	75	22	20	51	6	62	96,5	0,65	SC 30 ES
35	84	25	22	61	6	80	112	1,00	SC 35 ES
40	94	28	24	69	7	100	134	1,30	SC 40 ES
45	104	32	28	77	7	127	180	1,90	SC 45 ES
50	114	35	31	88	6	156	220	2,50	SC 50 ES
60	137	44	39	100	6	245	335	4,60	SC 60 ES
70	162	49	43	115	6	315	455	6,80	SC 70 ES
80	182	55	48	141	6	400	550	9,70	SC 80 ES

Dimensions

d	d _k	d ₅ max	d ₆	l ₆ max	l ₇ min	r ₁ min	r ₂
mm							
20	29	29	4	66	24	0,3	2
25	35,5	35	4	78	30	0,6	3
30	40,7	42	4	89	34	0,6	3
35	47	49	4	104	40	0,6	3
40	53	54	4	118	46	0,6	4
45	60	60	6	132	50	0,6	4
50	66	64	6	150	58	0,6	4
60	80	72	6	173	73	1	4
70	92	82	6	199	85	1	5
80	105	97	6	237	98	1	5

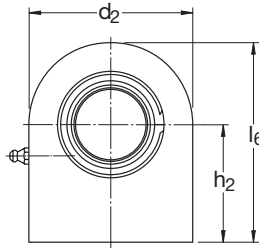
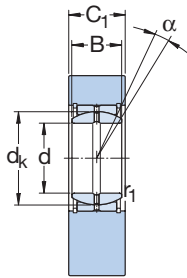

Principal dimensions					Angle of tilt α	Basic load ratings		Mass	Designations
d	d ₂ max	B	C ₁ max	h ₂ js13		dynamic C	static C ₀		
mm					degrees	kN		kg	–
20	51,5	16	20	38	9	30	63	0,35	SCF 20 ES
25	56,5	20	24	45	7	48	65,5	0,53	SCF 25 ES
30	66,5	22	29	51	6	62	110	0,87	SCF 30 ES
35	85	25	31	61	6	80	183	1,55	SCF 35 ES
40	102	28	36,5	69	7	100	285	2,45	SCF 40 ES
45	112	32	41,5	77	7	127	360	3,40	SCF 45 ES
50	125,5	35	41,5	88	6	156	415	4,45	SCF 50 ES
60	142,5	44	51,5	100	6	245	530	7,00	SCF 60 ES
70	166,5	49	57	115	6	315	680	10,0	SCF 70 ES
80	182,5	55	62	141	6	400	750	15,0	SCF 80 ES

Dimensions

d	d _k	l ₆ max	r ₁ min
---	----------------	-----------------------	-----------------------

mm

20	29	64	0,3
25	35,5	73,5	0,6
30	40,7	85	0,6
35	47	103,5	0,6
40	53	120	0,6
45	60	133	0,6
50	66	151	0,6
60	80	171,5	1
70	92	198,5	1
80	105	232,5	1

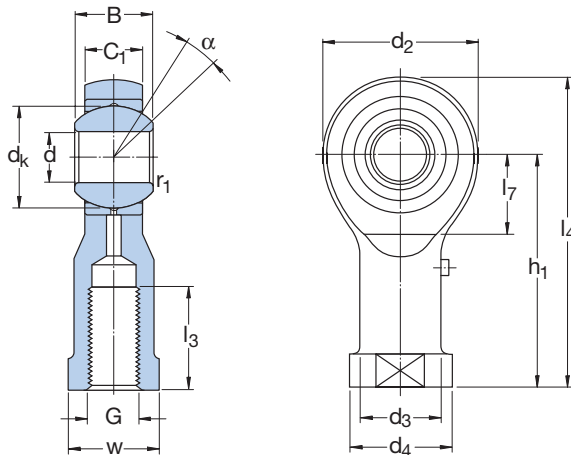

Principal dimensions						Angle of tilt	Basic load ratings		Mass	Designations	
d	d ₂ max	G 6H	B	C ₁ max	h ₁	α	C	C ₀		Rod end with right-hand thread	left-hand thread
mm						degrees	kN		kg	–	
5	19	M 5	8	6	27	13	3,25	5,4	0,017	SIKAC 5 M ¹⁾	SILKAC 5 M ¹⁾
6	21	M 6	9	6,75	30	13	4,3	5,4	0,025	SIKAC 6 M	SILKAC 6 M
8	25	M 8	12	9	36	14	7,2	9,15	0,043	SIKAC 8 M	SILKAC 8 M
10	29	M 10	14	10,5	43	13	10	12,2	0,072	SIKAC 10 M	SILKAC 10 M
	29	M 10×1,25	14	10,5	43	13	10	12,2	0,072	SIKAC 10 M/VZ019	–
12	33	M 12	16	12	50	13	13,4	14	0,11	SIKAC 12 M	SILKAC 12 M
	33	M 12×1,25	16	12	50	13	13,4	14	0,11	SIKAC 12 M/VZ019	–
14	37	M 14	19	13,5	57	16	17	20,4	0,16	SIKAC 14 M	SILKAC 14 M
16	43	M 16	21	15	64	15	21,6	29	0,22	SIKAC 16 M	SILKAC 16 M
	43	M 16×1,5	21	15	64	15	21,6	29	0,22	SIKAC 16 M/VZ019	–
18	47	M 18×1,5	23	16,5	71	15	26	35,5	0,30	SIKAC 18 M	SILKAC 18 M
20	51	M 20×1,5	25	18	77	14	31,5	35,5	0,40	SIKAC 20 M	SILKAC 20 M
22	55	M 22×1,5	28	20	84	15	38	45	0,50	SIKAC 22 M	SILKAC 22 M
25	61	M 24×2	31	22	94	15	47,5	53	0,65	SIKAC 25 M	SILKAC 25 M
30	71	M 30×2	37	25	110	17	64	69,5	1,15	SIKAC 30 M	SILKAC 30 M

¹⁾ Without lubrication nipple

Dimensions

d	d _k	d ₃ ≈	d ₄ max	l ₃ min	l ₄ max	l ₅ ≈	l ₇ min	r ₁ min	w h14
mm									
5	11,1	9	12	8	38	4	9	0,3	9
6	12,7	10	14	9	42	5	10	0,3	11
8	15,8	12,5	17	12	50	5	12	0,3	14
10	19	15	20	15	59	6,5	14	0,3	17
	19	15	20	15	59	6,5	14	0,3	17
12	22,2	17,5	23	18	68	6,5	16	0,3	19
	22,2	17,5	23	18	68	6,5	16	0,3	19
14	25,4	20	27	21	77	8	18	0,3	22
16	28,5	22	29	24	87	8	21	0,3	22
	28,5	22	29	24	87	8	21	0,3	22
18	31,7	25	32	27	96	10	23	0,3	27
20	34,9	27,5	37	30	105	10	25	0,3	30
22	38,1	30	40	33	114	12	27	0,3	32
25	42,8	33,5	44	36	127	12	30	0,3	36
30	50,8	40	52	45	148	15	35	0,3	41

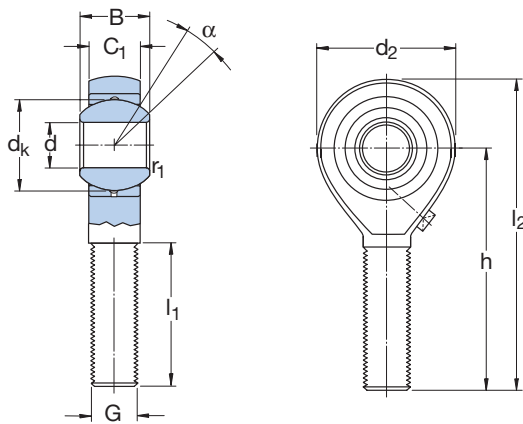

Principal dimensions						Angle of tilt	Basic load ratings		Mass	Designations	
d	d ₂ max	G 6g	B	C ₁ max	h	α	C	C ₀		Rod end with right-hand thread	left-hand thread
mm						degrees	kN		kg	–	
5	19	M 5	8	6	33	13	3,25	4,8	0,013	SAKAC 5 M ¹⁾	SALKAC 5 M ¹⁾
6	21	M 6	9	6,75	36	13	4,3	4,8	0,020	SAKAC 6 M	SALKAC 6 M
8	25	M 8	12	9	42	14	7,2	8	0,032	SAKAC 8 M	SALKAC 8 M
10	29	M 10	14	10,5	48	13	10	10,8	0,054	SAKAC 10 M	SALKAC 10 M
12	33	M 12	16	12	54	13	12,2	12,2	0,085	SAKAC 12 M	SALKAC 12 M
14	37	M 14	19	13,5	60	16	17	17,3	0,13	SAKAC 14 M	SALKAC 14 M
16	43	M 16	21	15	66	15	21,6	23,2	0,19	SAKAC 16 M	SALKAC 16 M
18	47	M 18×1,5	23	16,5	72	15	26	29	0,26	SAKAC 18 M	SALKAC 18 M
20	51	M 20×1,5	25	18	78	14	29	29	0,34	SAKAC 20 M	SALKAC 20 M
22	55	M 22×1,5	28	20	84	15	38	39	0,44	SAKAC 22 M	SALKAC 22 M
25	61	M 24×2	31	22	94	15	46,5	46,5	0,60	SAKAC 25 M	SALKAC 25 M
30	71	M 30×2	37	25	110	17	61	61	1,05	SAKAC 30 M	SALKAC 30 M

¹⁾ Without lubrication nipple

Dimensions

d	d _k	l ₁ min	l ₂ max	r ₁ min
mm				
5	11,1	19	44	0,3
6	12,7	21	48	0,3
8	15,8	25	56	0,3
10	19	28	64	0,3
12	22,2	32	72	0,3
14	25,4	36	80	0,3
16	28,5	37	89	0,3
18	31,7	41	97	0,3
20	34,9	45	106	0,3
22	38,1	48	114	0,3
25	42,8	55	127	0,3
30	50,8	66	148	0,3

Maintenance-free rod ends



SKF maintenance-free rod ends are produced with three different sliding contact surface combinations.

The rod ends with the sliding contact surface combinations steel/sinter bronze composite (→ **fig 1**) and steel/PTFE fabric (→ **fig 2**) comprise a rod end housing and a standard spherical plain bearing, the outer ring of which is held in position axially.

The rod ends with the sliding contact surface combination steel/PTFE composite (→ **fig 3**) consist of a rod end housing and a spherical plain bearing inner ring. Between the housing and the inner ring, a sliding layer of glass fibre reinforced plastic containing PTFE is injection moulded in situ.

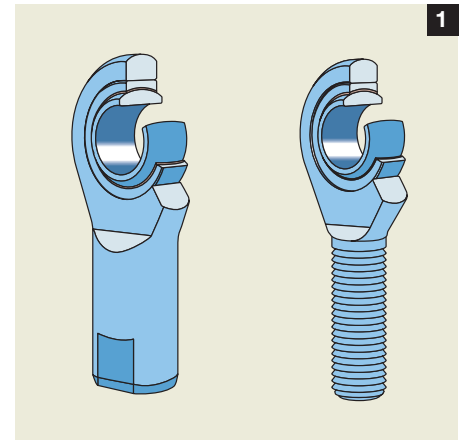

Maintenance-free rod end, steel/sinter bronze composite

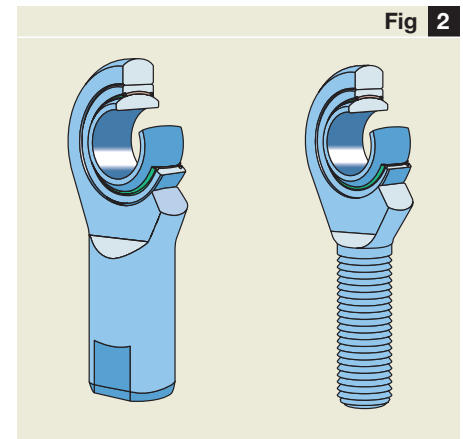

Maintenance-free rod end, steel/PTFE fabric

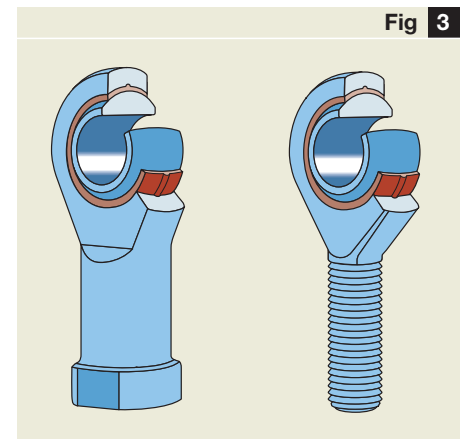

Maintenance-free rod end, steel/PTFE composite

Dimensions

The dimensions of the maintenance-free rod ends conform to ISO 12240-4:1998. Those rod ends which carry the designation suffix /VZ019 have a thread which deviates from that specified in ISO 12240-4 but is in accordance with the CETOP¹⁾ recommendation RP 103 P and ISO 8139:1991.

The female and male threads of SKF rod ends are in accordance with ISO 965-1:1998.

Tolerances

The tolerances of SKF rod ends are in accordance with the tolerances specified in ISO 12240-4:1998. The actual tolerance values are given in **Table 1**.

The symbols used in **Table 1** are explained in the following.

- d nominal bore diameter
- Δ_{dmp} deviation of the mean bore diameter from the nominal
- Δ_{Bs} deviation of single inner ring width from the nominal

Internal clearance, preload

SKF maintenance-free rod ends, because of their design, have a radial internal clearance but may also have a light preload. Therefore, **Tables 2** and **3** show maximum values for the radial internal clearance as well as for the friction torque in the circumferential direction caused by preload.

Table 1

Bore diameter d	Series SA(A) and SI(A)		Series SAKB and SIKB					
	Δ_{dmp}	Δ_{Bs}	Δ_{dmp}		Δ_{Bs}			
over incl.	high low	high low	high	low	high	low		
mm	μm	μm	μm	μm	μm	μm		
6	0	-8	0	-120	+12	0	0	-120
6 10	0	-8	0	-120	+15	0	0	-120
10 18	0	-8	0	-120	+18	0	0	-120
18 30	0	-10	0	-120	-	-	-	-
30 50	0	-12	0	-120	-	-	-	-
50 80	0	-15	0	-150	-	-	-	-

Tolerances for maintenance-free rod end inner rings

Table 2

Bore diameter d	Radial internal clearance max	Friction torque max
mm	μm	Nm
12	28	0,15
12 20	35	0,25
20 30	44	0,40
30 35	50	2,5
35 40	60	2,5
40 45	60	3,5
50 60	60	4
60 70	72	5

*Radial internal clearance and friction torque for steel/sinter bronze composite and steel/PTFE fabric rod ends
Series SA(A) and SI(A)*

Table 3

Bore diameter d	Radial internal clearance max	Friction torque max
mm	μm	Nm
5	50	0,20
6	50	0,25
8	50	0,30
10	75	0,40
12	75	0,50
14	75	0,60
16	75	0,70
18	85	0,80
20	100	1

*Radial internal clearance and friction torque for steel/PTFE composite rod ends
Series SAKB and SIKB*

¹⁾ CETOP = Comité Européen des Transmissions Oléohydrauliques et Pneumatiques (European Committee for Hydraulic and Pneumatic Transmissions)

Rod end housing materials

Table 4			
Series	Size	Material	Material No.
SA(A) SI(A)	6 .. 80	Heat treatable steel C45V zinc coated and chromitized	1.0503
SAKB	5 .. 12	Automatic steel 9 SMnPb 28 K zinc coated and chromitized	1.0718
SIKB	14 .. 20	Heat treatable steel C35N zinc coated and chromitized	1.0501

Materials

The materials used for the rod end housings of SKF maintenance-free rod ends are listed in **Table 4**. The right is reserved to make changes dictated by technical developments.

Details of the materials used for the maintenance-free spherical plain bearings incorporated in the rod ends will be found in **Matrix 1**, **page 73**.

The inner rings of rod ends with the sliding contact surface combination steel/PTFE composite are of bearing steel which is hardened and ground and the sliding contact surface is hard chromium plated. The sliding layer of these bearings consists of a glass fibre reinforced polymer containing PTFE.

Permissible operating temperature range

Table 5			
Series	Permissible operating temperature range		Reduced load carrying capacity from
	from	incl.	
–	°C		°C
Steel/sinter bronze composite			
SA .. C SI .. C	–50	+150	+80
Steel/PTFE fabric			
SA(A) .. TXE-2LS SI(A) .. TXE-2LS	–30	+130	+60
Steel/PTFE composite			
SAKB .. F SIKB .. F SIKB .. F/VZ019	–40	+75	+50

Permissible operating temperature range

The permissible operating temperature range for SKF maintenance-free rod ends is governed by the rod end housing, the spherical plain bearing incorporated and the bearing seals. The ranges are given in **Table 5**.

Fatigue strength

In applications where the rod end is subjected to loads of alternating magnitude or direction, or where rod end failure could be dangerous, it is necessary to check the fatigue strength of the rod end.

Maintenance-free rod ends with female thread with sliding contact surface combination steel/sinter bronze composite
 d 6 – 30 mm

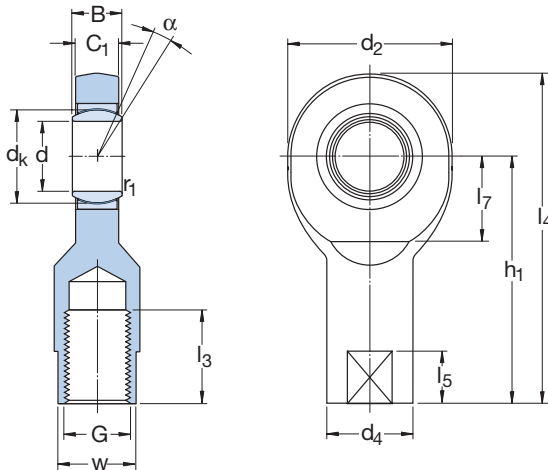

Principal dimensions						Angle of tilt	Basic load ratings		Mass	Designations	
d	d ₂ max	G 6H	B	C ₁ max	h ₁	α	C	C ₀		Rod end with right-hand thread	left-hand thread
mm						degrees	kN		kg	–	
6	22	M 6	6	4,5	30	13	3,6	8,15	0,023	SI 6 C	SIL 6 C
8	25	M 8	8	6,5	36	15	5,8	12,9	0,036	SI 8 C	SIL 8 C
10	30	M 10	9	7,5	43	12	8,65	19	0,065	SI 10 C	SIL 10 C
12	35	M 12	10	8,5	50	10	11,4	25,5	0,11	SI 12 C	SIL 12 C
15	41	M 14	12	10,5	61	8	18	37,5	0,18	SI 15 C	SIL 15 C
17	47	M 16	14	11,5	67	10	22,4	46,5	0,25	SI 17 C	SIL 17 C
20	54	M 20×1,5	16	13,5	77	9	31,5	57	0,35	SI 20 C	SIL 20 C
25	65	M 24×2	20	18	94	7	51	90	0,65	SI 25 C	SIL 25 C
30	75	M 30×2	22	20	110	6	65,5	118	1,05	SI 30 C	SIL 30 C

Dimensions

d	d _k	d ₄ ≈	l ₃ min	l ₄ max	l ₅ ≈	l ₇ min	r ₁ min	w h14
mm								
6	10	11	11	43	8	10	0,3	9
8	13	13	15	50	9	11	0,3	11
10	16	16	15	60	11	13	0,3	14
12	18	19	18	69	12	17	0,3	17
15	22	22	21	83	14	19	0,3	19
17	25	25	24	92	15	22	0,3	22
20	29	28	30	106	16	24	0,3	24
25	35,5	35	36	128	18	30	0,6	30
30	40,7	42	45	149	19	34	0,6	36

Maintenance-free rod ends with male thread with sliding contact surface combination steel/sinter bronze composite
 d 6 – 30 mm

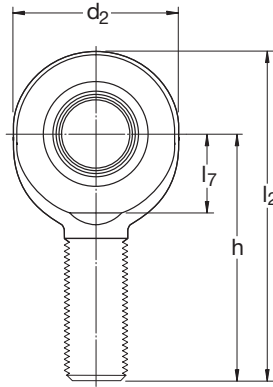
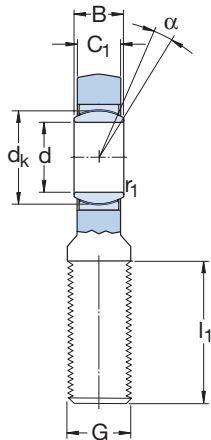

Principal dimensions						Angle of tilt	Basic load rating		Mass	Designations	
d	d ₂ max	G 6g	B	C ₁ max	h	α	C	C ₀		Rod end with right-hand thread	left-hand thread
mm						degrees	kN		kg	–	
6	22	M 6	6	4,5	36	13	3,6	8,15	0,017	SA 6 C	SAL 6 C
8	25	M 8	8	6,5	42	15	5,85	12,9	0,030	SA 8 C	SAL 8 C
10	30	M 10	9	7,5	48	12	8,65	18,3	0,053	SA 10 C	SAL 10 C
12	35	M 12	10	8,5	54	10	11,4	24,5	0,078	SA 12 C	SAL 12 C
15	41	M 14	12	10,5	63	8	18	34,5	0,13	SA 15 C	SAL 15 C
17	47	M 16	14	11,5	69	10	22,4	42,5	0,19	SA 17 C	SAL 17 C
20	54	M 20×1,5	16	13,5	78	9	31,5	51	0,32	SA 20 C	SAL 20 C
25	65	M 24×2	20	18	94	7	51	78	0,57	SA 25 C	SAL 25 C
30	75	M 30×2	22	20	110	6	65,5	104	0,90	SA 30 C	SAL 30 C

Dimensions

d	d _k	l ₁ min	l ₂ max	l ₇ min	r ₁ min
---	----------------	-----------------------	-----------------------	-----------------------	-----------------------

 mm

6	10	16	49	10	0,3
8	13	21	56	11	0,3
10	16	26	65	13	0,3
12	18	28	73	17	0,3
15	22	34	85	19	0,3
17	25	36	94	22	0,3
20	29	43	107	24	0,3
25	35,5	53	128	30	0,6
30	40,7	65	149	34	0,6

Maintenance-free rod ends with female thread with sliding contact surface combination steel/PTFE fabric
d 35 – 70 mm

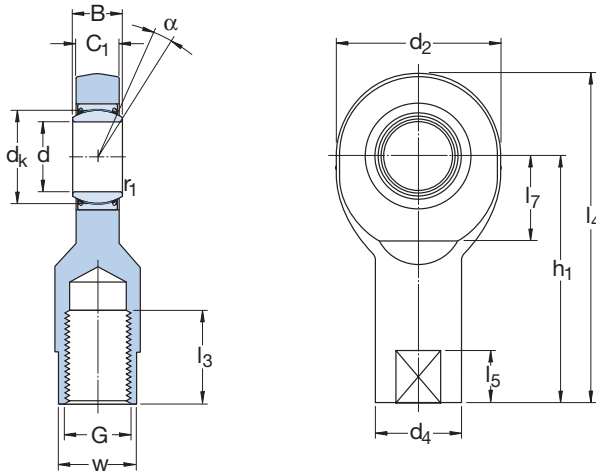

Principal dimensions						Angle of tilt	Basic load ratings		Mass	Designations	
d	d ₂ max	G 6H	B	C ₁ max	h ₁	α	C	C ₀		Rod end with right-hand thread	left-hand thread
mm						degrees	kN		kg	–	
35	84	M 36×3	25	22	130	6	224	134	1,40	SI 35 TXE-2LS	SIL 35 TXE-2LS
	94	M 39×3	28	24	142	7	280	166	2,20	SIA 40 TXE-2LS	SILA 40 TXE-2LS
40	94	M 42×3	28	24	145	7	280	166	2,30	SI 40 TXE-2LS	SIL 40 TXE-2LS
	104	M 45×3	32	28	165	7	360	224	2,90	SIA 45 TXE-2LS	SILA 45 TXE-2LS
45	104	M 45×3	32	28	165	7	360	224	3,20	SI 45 TXE-2LS	SIL 45 TXE-2LS
	114	M 48×3	35	31	180	6	440	270	4,10	SIA 50 TXE-2LS	SILA 50 TXE-2LS
50	114	M 52×3	35	31	195	6	440	270	4,50	SI 50 TXE-2LS	SIL 50 TXE-2LS
	137	M 55×3	44	39	215	6	695	400	6,30	SIA 60 TXE-2LS	SILA 60 TXE-2LS
60	137	M 60×4	44	39	225	6	695	400	7,10	SI 60 TXE-2LS	SIL 60 TXE-2LS
	162	M 66×4	49	43	265	6	880	530	10,5	SIA 70 TXE-2LS	SILA 70 TXE-2LS
70	162	M 72×4	49	43	265	6	880	530	10,5	SI 70 TXE-2LS	SIL 70 TXE-2LS
80	182	M 80×4	55	48	295	6	1 140	655	19,0	SIA 80 TXE-2LS	SILA 80 TXE-2LS

Dimensions

d	d _k	d ₄ ≈	l ₃ min	l ₄ max	l ₅ ≈	l ₇ min	r ₁ min	w h14
mm								
35	47	49	60	174	25	40	0,6	41
40	53	58	65	191	25	46	0,6	50
	53	58	65	194	25	46	0,6	50
45	60	65	65	199	30	50	0,6	55
	60	65	65	219	30	50	0,6	55
50	66	70	68	246	30	58	0,6	60
	66	70	68	254	30	58	0,6	60
60	80	82	70	246	35	73	1	70
	80	82	70	296	35	73	1	70
70	92	92	80	349	40	85	1	80
80	105	105	85	389	40	98	1	90

Maintenance-free rod ends with male thread with sliding contact surface combination steel/PTFE fabric
d 35 – 70 mm

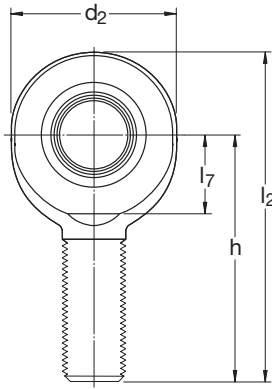
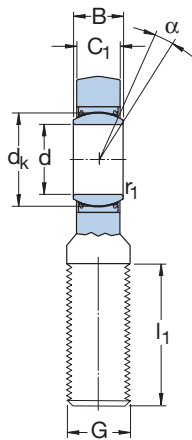

Principal dimensions						Angle of tilt	Basic load ratings		Mass	Designations	
d	d ₂ max	G 6g	B	C ₁ max	h	α	C	C ₀		Rod end with right-hand thread	left-hand thread
mm						degrees	kN		kg	–	
35	84	M 36×3	25	22	130	6	224	110	1,30	SA 35 TXE-2LS	SAL 35 TXE-2LS
40	94	M 39×3	28	24	150	6	280	140	1,85	SAA 40 TXE-2LS	SALA 40 TXE-2LS
	94	M 42×3	28	24	145	6	280	140	1,90	SA 40 TXE-2LS	SAL 40 TXE-2LS
45	104	M 42×3	32	28	163	7	360	200	2,45	SAA 45 TXE-2LS	SALA 45 TXE-2LS
	104	M 45×3	32	28	165	7	360	200	2,55	SA 45 TXE-2LS	SAL 45 TXE-2LS
50	114	M 45×3	35	31	185	6	440	245	3,30	SAA 50 TXE-2LS	SALA 50 TXE-2LS
	114	M 52×3	35	31	195	6	440	245	3,90	SA 50 TXE-2LS	SAL 50 TXE-2LS
60	137	M 52×3	44	39	210	6	695	360	5,70	SAA 60 TXE-2LS	SALA 60 TXE-2LS
	137	M 60×4	44	39	225	6	695	360	6,25	SA 60 TXE-2LS	SAL 60 TXE-2LS
70	162	M 72×4	49	43	265	6	880	490	10,0	SA 70 TXE-2LS	SAL 70 TXE-2LS
80	182	M 80×4	55	48	295	5	1 140	585	14,5	SA 80 TXE-2LS	SAL 80 TXE-2LS

Dimensions

d	d _k	l ₁ min	l ₂ max	l ₇ min	r ₁ min
mm					
35	47	82	174	40	0,6
40	53	86	199	46	0,6
	53	90	194	46	0,6
45	60	92	217	50	0,6
	60	95	219	50	0,6
50	66	104	244	58	0,6
	66	110	254	58	0,6
60	80	115	281	73	1
	80	120	296	73	1
70	92	132	349	85	1
80	105	147	389	98	1

Maintenance-free rod ends with female thread with sliding contact surface combination steel/PTFE composite
d 5 – 20 mm

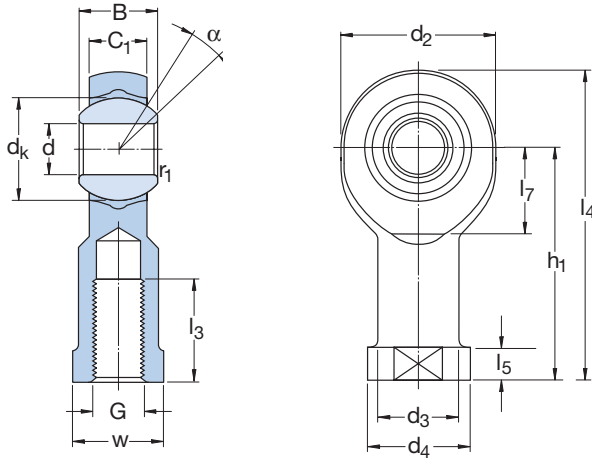

Principal dimensions						Angle of tilt	Basic load ratings		Mass	Designations	
d	d ₂ max	G 6H	B	C ₁ max	h ₁	α	C	C ₀		Rod end with right-hand thread	left-hand thread
mm						degrees	kN		kg	–	
5	19	M 5	8	6	27	13	3,25	5,3	0,019	SIKB 5 F	SILKB 5 F
6	21	M 6	9	6,75	30	13	4,25	6,8	0,028	SIKB 6 F	SILKB 6 F
8	25	M 8	12	9	36	14	7,1	11,4	0,047	SIKB 8 F	SILKB 8 F
10	29	M 10	14	10,5	43	13	9,8	14,3	0,079	SIKB 10 F	SILKB 10 F
	29	M 10×1,25	14	10,5	43	13	9,8	14,3	0,079	SIKB 10 F/VZ019	–
12	33	M 12	16	12	50	13	13,2	17	0,12	SIKB 12 F	SILKB 12 F
	33	M 12×1,25	16	12	50	13	13,2	17	0,12	SIKB 12 F/VZ019	–
14	37	M 14	19	13,5	57	16	17	27,5	0,16	SIKB 14 F	SILKB 14 F
16	43	M 16	21	15	64	15	21,4	34,5	0,23	SIKB 16 F	SILKB 16 F
	43	M 16×1,5	21	15	64	15	21,4	34,5	0,23	SIKB 16 F/VZ019	–
18	47	M 18×1,5	23	16,5	71	15	26	41,5	0,33	SIKB 18 F	SILKB 18 F
20	51	M 20×1,5	25	18	77	14	31	50	0,38	SIKB 20 F	SILKB 20 F

Dimensions

d	d _k	d ₃ ≈	d ₄ max	l ₃ min	l ₄ max	l ₅ ≈	l ₇ min	r ₁ min	w h14
mm									
5	11,1	9	12	8	37	4	9	0,3	9
6	12,7	10	14	9	41	5	10	0,3	11
8	15,8	12,5	17	12	49	5	12	0,3	14
10	19	15	20	15	58	6,5	14	0,3	17
	19	15	20	15	58	6,5	14	0,3	17
12	22,2	17,5	23	18	67	6,5	16	0,3	19
	22,2	17,5	23	18	67	6,5	16	0,3	19
14	25,4	20	27	21	76	8	18	0,3	22
16	28,5	22	29	24	86	8	21	0,3	22
	28,5	22	29	24	86	8	21	0,3	22
18	31,7	25	32	27	95	10	23	0,3	27
20	34,9	27,5	37	30	103	10	25	0,3	30

Maintenance-free rod ends with male thread with sliding contact surface combination steel/PTFE composite
 d 5 – 20 mm

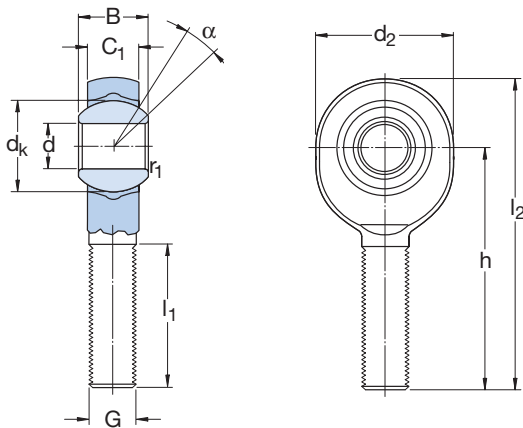

Principal dimensions						Angle of tilt	Basic load ratings		Mass	Designations	
d	d ₂ max	G 6g	B	C ₁ max	h	α	C	C ₀		Rod end with right-hand thread	left-hand thread
mm						degrees	kN		kg	–	
5	19	M 5	8	6	33	13	3,25	5,3	0,015	SAKB 5 F	SALKB 5 F
6	21	M 6	9	6,75	36	13	4,25	6,8	0,021	SAKB 6 F	SALKB 6 F
8	25	M 8	12	9	42	14	7,1	10	0,035	SAKB 8 F	SALKB 8 F
10	29	M 10	14	10,5	48	13	9,8	12,5	0,059	SAKB 10 F	SALKB 10 F
12	33	M 12	16	12	54	13	13,2	15	0,10	SAKB 12 F	SALKB 12 F
14	37	M 14	19	13,5	60	16	17	25,5	0,13	SAKB 14 F	SALKB 14 F
16	43	M 16	21	15	66	15	21,4	34,5	0,20	SAKB 16 F	SALKB 16 F
18	47	M 18×1,5	23	16,5	72	15	26	41,5	0,26	SAKB 18 F	SALKB 18 F
20	51	M 20×1,5	25	18	78	14	31	50	0,37	SAKB 20 F	SALKB 20 F

Dimensions

d	d _k	l ₁ min	l ₂ max	r ₁ min
---	----------------	-----------------------	-----------------------	-----------------------

mm

5	11,1	19	44	0,3
6	12,7	21	48	0,3
8	15,8	25	56	0,3
10	19	28	64	0,3
12	22,2	32	72	0,3
14	25,4	36	80	0,3
16	28,5	37	89	0,3
18	31,7	41	97	0,3
20	34,9	45	106	0,3

Special solutions and related SKF products

Plain bearings for road vehicles

Special applications such as the bearing arrangements for centring propeller shafts or gear shifts require special spherical plain bearings or bearing units. SKF has developed appropriate products in close cooperation with customers and manufactures them in large volumes.

Plain bearings for rail vehicles

The SKF plain bearing range for railway vehicles includes bogie swivel bearings for trams and heavy duty goods wagons as well as spherical plain bearings and rod ends for transverse stabilizers, tilting mechanisms etc.



Spherical plain bearings and rod ends for the aircraft industry

In the aircraft industry spherical plain bearings and rod ends take a prominent place as airframe bearings for the transmission of rotating, tilting and oscillating movements. The SKF specialist company for airframe products is SARMA, producing spherical plain bearings and rod ends for the suspension of engines and auxiliary equipment, as well those needed for use in undercarriages, spoilers, height and side rudders, wing flaps etc.

SARMA manufactures spherical plain bearings and rod ends in steel, stainless steel and composite materials in various sliding contact surface combinations: some requiring maintenance and some being maintenance-free.

Airframe control rods and structural rods of light alloy, steel, titanium and composite materials in a wide variety of designs are produced by SARMA for a multitude of applications in other fields as well as the aircraft industry.

Direct contact:

SARMA

1 avenue Marc Seguin
Parc Industriel de la Brassière
F-26241 Saint Vallier sur Rhône
Cedex
France

Telephone: +33 4 75 03 40 40

Fax: +33 4 75 30 40 00



Bushings and flanged bushings

Bushings and flanged bushings have been part of the SKF product range for more than thirty years and the most varied assortment is available from stock. A comprehensive range of materials is available including the following.

- **Solid bronze bushings**
The traditional robust bushings
- **Sintered bronze bushings**
These are impregnated with oil and can be operated at high speed
- **Wrapped bronze bushings**
The lubricant pockets allow them to function well even in dirty environments
- **PTFE composite bushings**
The low friction enables long periods of maintenance-free operation

- **POM composite bushings**
These require little maintenance even under arduous conditions
- **Stainless backed composite bushings**
These are appropriate for corrosive environments
- **PTFE/polyamide bushings**
The cost-favourable, maintenance-free bushings for light loads
- **Filament wound bushings**
The maintenance-free bushings for extreme conditions

Because of the great variety of SKF bushings they are to be found in all branches of industry irrespective of whether

- freedom from maintenance is required, or not;
 - lubricants or other media are present, or not;
- and where
- rotational, slewing or linear movement must be accommodated.

See brochure 4741 "SKF bushings", brochure 5110 "Composite dry sliding bearings – maintenance-free and space-saving" or the "SKF Interactive Engineering Catalogue" on CD-ROM or online at www.skf.com.



Thrust washers and strips

For thrust bearing arrangements that make oscillating or slow rotational movements, thrust washers are available made of two different triple layer composite materials:

- SKF thrust washers of B material (PTFE composite), and
- SKF thrust washers of M material (POM composite).

The thrust washers are primarily intended for applications where axial space is extremely limited and where freedom from maintenance is required or where lubricant starvation can occur.

SKF also supplies strip of the same triple layer composite materials – B and M. The strip can be bent, pressed or coined to form, for example, linear guides with flat, L-shaped or V-shaped profiles or many other dry sliding components.

See brochure 5110 “Composite dry sliding bearings – maintenance-free and space-saving” or the “SKF Interactive Engineering Catalogue” on CD-ROM or online at www.skf.com.

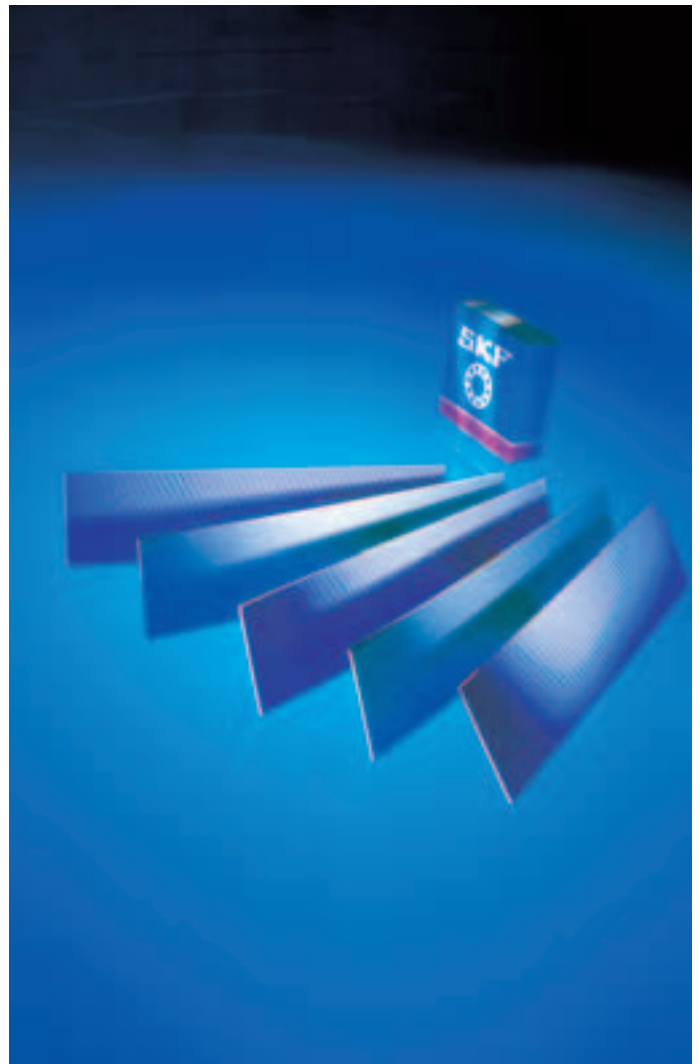

SKF - The knowledge engineering company

The business of the SKF Group consists of the design, manufacture and marketing of the world's leading brand of rolling bearings, with a global leadership position in complementary products such as radial seals. SKF also holds an increasingly important position in the market for linear motion products, high precision aerospace bearings, machine tool spindles, as well as plant maintenance services and is an established producer of high-quality bearing steel.

The SKF Group maintains specialized businesses to meet the needs of the global marketplace. SKF supports specific market segments with ongoing research and development efforts that have led to a growing number of innovations, new standards and new products.

SKF Group has global ISO 14001 environmental certification. Individual divisions have been approved for quality certification in accordance with either ISO 9000 or appropriate industry specific standards.

Some 80 manufacturing sites worldwide and sales companies in 70 countries make SKF a truly international corporation. In addition, our 7 000 distributor and dealer partners around the world, e-business marketplace and global distribution system put SKF close to customers for the supply of both products and services. In essence, SKF solutions are available wherever and whenever our customers need them.

Overall, the SKF brand now stands for more than ever before. It stands for the knowledge engineering company ready to serve you with world-class product competences, intellectual resources and the vision to help you succeed.



Harnessing wind power

The growing industry of wind-generated electric power provides an environmentally compatible source of electricity. SKF is working closely with global industry leaders to develop efficient and trouble-free turbines, using SKF knowledge to provide highly specialized bearings and condition monitoring systems to extend equipment life in the extreme and often remote environments of wind farms.

Developing a cleaner cleaner

The electric motor and its bearings are the heart of many household appliances. SKF works closely with appliance manufacturers to improve their product performance, cut costs and reduce weight. A recent



example produced a new generation of vacuum cleaners with substantially more suction. SKF's knowledge in small bearing technology is also applied to manufacturers of power tools and office equipment.



Delivering asset efficiency optimization

To optimize efficiency and boost productivity, many industrial facilities outsource some or all of their maintenance services to SKF, often with guaranteed performance contracts. Through the specialized capabilities and knowledge available from

SKF Reliability Systems, SKF provides a comprehensive range of asset efficiency services, from maintenance strategies and engineering assistance, to operator-driven reliability and machine maintenance programs.



Creating a new “cold remedy”

In the frigid winters of northern China, sub-zero temperatures can cause rail car wheel assemblies and their bearings to seize due to lubrication starvation. SKF created a new family of synthetic lubricants formulated to retain their lubrication viscosity even at these extreme bearing temperatures. SKF’s knowledge of lubricants and friction are unmatched throughout the world.



Planning for sustainable growth

By their very nature, bearings make a positive contribution to the natural environment. Reduced friction enables machinery to operate more efficiently, consume less power and require less lubrication. SKF is continually raising the performance bar, enabling new generations of high-efficiency products and equipment. With an eye to the future, SKF’s global policies and manufacturing techniques are planned and implemented to help protect and preserve the earth’s limited natural resources. We remain committed to sustainable, environmentally responsible growth.

Evolving by-wire technology

SKF has unique expertise and knowledge in fast growing by-wire technology, from fly-by-wire, to drive-by-wire, to work-by-wire. SKF pioneered practical fly-by-wire technology and is a close working partner with all aerospace industry leaders. As an example, virtually all aircraft of the Airbus design use SKF by-wire systems for cockpit flight control. SKF is also a leader in automotive drive-by-wire,

having jointly developed the revolutionary Filo and Novanta concept cars which employ SKF mechatronics for steering and braking. Further by-wire development has led SKF to produce an all-electric forklift truck which uses mechatronics rather than hydraulics for all controls.



Maintaining a 320 km/h R&D lab

In addition to SKF’s renowned research and development facilities in Europe and the United States, Formula One car racing provides a unique environment for SKF to push the limits of bearing technology. For over 50 years, SKF products, engineering and knowledge have helped make

Scuderia Ferrari a formidable force in F1 racing. (The average racing Ferrari utilizes more than 150 SKF components.) Lessons learned here are applied to the products we provide to automakers and the after-market worldwide.

® SKF is a registered trademark of the SKF Group.

© Copyright SKF 2004

The contents of this publication are the copyright of the publisher and may not be reproduced (even extracts) unless permission is granted. Every care has been taken to ensure the accuracy of the information contained in this publication but no liability can be accepted for any loss or damage whether direct, indirect or consequential arising out of the use of the information contained herein.

Publication **4407/II E** · April 2004

Printed in Sweden on environmentally friendly, chlorine-free paper (Tom&Otto Silk) by SG Tryck AB.