

**SKF**

# Rolling bearings in electric motors and generators



® SKF, CARB, INSOCOAT, MARLIN  
and MICROLOG are registered trade-  
marks of the SKF Group.

™ Machine Analyst is a trademark of  
the SKF Group.

© Copyright SKF 2004

The contents of this publication are the  
copyright of the publisher and may not  
be reproduced (even extracts) unless  
permission is granted. Every care has  
been taken to ensure the accuracy of  
the information contained in this pub-  
lication but no liability can be accepted  
for any loss or damage whether direct,  
indirect or consequential arising out of  
the use of the information contained  
herein.

Publication **5230 E**

Printed in Denmark on environmentally  
friendly, chlorine-free paper (Multiart  
Silk) by Scanprint as.

**1 Rolling bearings in electric machines**

1

**2 Bearing arrangements**

2

**3 Tolerances and fits**

3

**4 Lubrication and sealing**

4

**5 Mounting and dismounting**

5

**6 Failure modes and corrective actions**

6

**7 SKF solutions**

7



# **Rolling bearings in electric motors and generators**

A handbook for the industrial designer  
and end-user



# Foreword

This SKF applications, lubrication and maintenance handbook for bearings in electric motors and generators has been developed with various industry specialists in mind. For designers of electric machines<sup>1)</sup>, this handbook provides the information needed to optimize a variety of bearing arrangements. For specialists working in various industries using electric machines, there are recommendations on how to maximize bearing service life through appropriate mounting, maintenance and lubrication.

The recommendations are based on experience gained by SKF during decades of close cooperation with manufacturers and users of electric machines all over the world. This experience along with customer input strongly influences product development within SKF, leading to the introduction of new products and variants.

General information regarding the selection and calculation of ball and roller bearings is provided in the General Catalogue. This publication deals with questions rising from the use of rolling bearings in electric motors and generators. Data from the General Catalogue is only repeated here when it has been thought necessary for the sake of clarity.

<sup>1)</sup> In this handbook, when the term electric machine is used, it refers to both an industrial electric motor and a generator

# Contents

The SKF brand now stands for more than ever before, and means more to you as a valued customer.

While SKF maintains its leadership as the hallmark of quality bearings throughout the world, new dimensions in technical advances, product support and services have evolved SKF into a truly solutions-oriented supplier, creating greater value for customers.

These solutions encompass ways to bring greater productivity to customers, not only with breakthrough application-specific products, but also through leading-edge design simulation tools and consultancy services, plant asset efficiency maintenance programmes, and the industry's most advanced supply management techniques.

The SKF brand still stands for the very best in rolling bearings, but it now stands for much more.

**SKF – The knowledge engineering company**



## **1 Rolling bearings in electric machines ..... 9**

Design requirements ..... 9

Bearing selection ..... 15

Calculation example ..... 17

Deep groove ball bearings ..... 21

Cylindrical roller bearings ..... 23

INSOCOAT® bearings ..... 25

Hybrid bearings ..... 27

Angular contact ball bearings ..... 29

Spherical roller bearings ..... 31

CARB® toroidal roller bearings ..... 33

Spherical roller thrust bearings ..... 35

## **2 Bearing arrangements ..... 37**

Selecting a bearing arrangement ..... 37

Preloading with springs ..... 47

## **3 Tolerances and fits ..... 51**

Shaft and housing tolerances ..... 52

Recommended fits ..... 54



<b>4 Lubrication and sealing .....</b>	<b>59</b>	<b>7 SKF solutions.....</b>	<b>103</b>
Lubrication.....	59	SKF Engineering Consultancy Services .....	104
Grease selection .....	62	SKF calculation tools.....	105
Relubrication intervals .....	64	Application specific solutions.....	107
Grease life in sealed bearings .....	70	Condition monitoring.....	111
Oil lubrication .....	72		
Seals.....	74		
<b>5 Mounting and dismounting .....</b>	<b>77</b>		
Mounting.....	77		
Dismounting .....	85		
<b>6 Failure modes and corrective actions.....</b>	<b>91</b>		
Electrical erosion .....	91		
Inadequate lubrication .....	94		
Bearing fatigue.....	96		
Damage from vibration .....	96		
Damage caused by improper installation and set-up.....	97		
Insufficient bearing load.....	99		
Other damage .....	99		

# SKF - The knowledge engineering company

The business of the SKF Group consists of the design, manufacture and marketing of the world's leading brand of rolling bearings, with a global leadership position in complementary products such as radial seals. SKF also holds an increasingly important position in the market for linear motion products, high precision aerospace bearings, machine tool spindles, as well as plant maintenance services and is an established producer of high-quality bearing steel.

The SKF Group maintains specialized businesses to meet the needs of the global marketplace. SKF supports specific market segments with ongoing research and development efforts that have led to a growing number of innovations, new standards and new products.

SKF Group has global ISO 14001 environmental certification. Individual divisions have been approved for quality certification in accordance with either ISO 9000 or appropriate industry specific standards.

Some 80 manufacturing sites worldwide and sales companies in 70 countries make SKF a truly international corporation. In addition, our 7 000 distributor and dealer partners around the world, e-business marketplace and global distribution system put SKF close to customers for the supply of both products and services. In essence, SKF solutions are available wherever and whenever our customers need them.

Overall, the SKF brand now stands for more than ever before. It stands for the knowledge engineering company ready to serve you with world-class product competences, intellectual resources and the vision to help you succeed.



## **Harnessing wind power**

*The growing industry of wind-generated electric power provides an environmentally compatible source of electricity. SKF is working closely with global industry leaders to develop efficient and trouble-free turbines, using SKF knowledge to provide highly specialized bearings and condition monitoring systems to extend equipment life in the extreme and often remote environments of wind farms.*

## **Developing a cleaner cleaner**

*The electric motor and its bearings are the heart of many household appliances. SKF works closely with appliance manufacturers to improve their product performance, cut costs and reduce weight. A recent*



*example produced a new generation of vacuum cleaners with substantially more suction. SKF's knowledge in small bearing technology is also applied to manufacturers of power tools and office equipment.*



## **Delivering asset efficiency optimization**

*To optimize efficiency and boost productivity, many industrial facilities outsource some or all of their maintenance services to SKF, often with guaranteed performance contracts. Through the specialized capabilities and knowledge available from*

*SKF Reliability Systems, SKF provides a comprehensive range of asset efficiency services, from maintenance strategies and engineering assistance, to operator-driven reliability and machine maintenance programs.*



**Creating a new “cold remedy”**

*In the frigid winters of northern China, sub-zero temperatures can cause rail car wheel assemblies and their bearings to seize due to lubrication starvation. SKF created a new family of synthetic lubricants formulated to retain their lubrication viscosity even at these extreme bearing temperatures. SKF’s knowledge of lubricants and friction are unmatched throughout the world.*



**Planning for sustainable growth**

*By their very nature, bearings make a positive contribution to the natural environment. Reduced friction enables machinery to operate more efficiently, consume less power and require less lubrication. SKF is continually raising the performance bar, enabling new generations of high-efficiency products and equipment. With an eye to the future, SKF’s global policies and manufacturing techniques are planned and implemented to help protect and preserve the earth’s limited natural resources. We remain committed to sustainable, environmentally responsible growth.*

**Evolving by-wire technology**

*SKF has unique expertise and knowledge in fast growing by-wire technology, from fly-by-wire, to drive-by-wire, to work-by-wire. SKF pioneered practical fly-by-wire technology and is a close working partner with all aerospace industry leaders. As an example, virtually all aircraft of the Airbus design use SKF by-wire systems for cockpit flight control. SKF is also a leader in automotive drive-by-wire,*

*having jointly developed the revolutionary Filo and Novanta concept cars which employ SKF mechatronics for steering and braking. Further by-wire development has led SKF to produce an all-electric forklift truck which uses mechatronics rather than hydraulics for all controls.*



**Maintaining a 320 km/h R&D lab**

*In addition to SKF’s renowned research and development facilities in Europe and the United States, Formula One car racing provides a unique environment for SKF to push the limits of bearing technology. For over 50 years, SKF products, engineering and knowledge have helped make*

*Scuderia Ferrari a formidable force in F1 racing. (The average racing Ferrari utilizes more than 150 SKF components.) Lessons learned here are applied to the products we provide to automakers and the after-market worldwide.*

## **1 Rolling bearings in electric machines**

<b>Design requirements</b> . . . . .	<b>9</b>
<b>Bearing selection</b> . . . . .	<b>15</b>
<b>Calculation example</b> . . . . .	<b>17</b>
<b>Deep groove ball bearings</b> .	<b>21</b>
<b>Cylindrical roller bearings</b> .	<b>23</b>
<b>INSOCOAT bearings</b> . . . . .	<b>25</b>
<b>Hybrid bearings</b> . . . . .	<b>27</b>
<b>Angular contact ball bearings</b> . . . . .	<b>29</b>
<b>Spherical roller bearings</b> . .	<b>31</b>
<b>CARB toroidal roller bearings</b> . . . . .	<b>33</b>
<b>Spherical roller thrust bearings</b> . . . . .	<b>35</b>



# Rolling bearings in electric machines

The purpose of using rolling bearings in electric machines is to support and locate the rotor, to keep the air gap small and consistent and to transfer loads from the shaft to the motor frame. The bearings should enable high and low speed operation, minimize friction, and save power. The designer has to consider many different parameters when selecting the bearing type and arrangement to meet the requirements of any particular motor application. Under all circumstances the design should be economical from both a manufacturing and a maintenance perspective.

## Design requirements

The design parameters of an electric machine are generally found to be power output, boundary dimensions, and shaft and housing materials. In the case of an induction motor, the number of poles required is also an important design parameter.

Other important considerations include the expected operating conditions, the required uptime or availability, maintenance requirements as well as manufacturing methods (→ **fig 1**, **page 10**).

Mounting and dismounting procedures need to be considered at the design stage (→ **chapter 5** “Mounting and dismounting”, starting on **page**

**77**). Selecting the proper lubricant and lubrication method can also have a significant impact on the service life of the machine. Condition monitoring (→ **chapter 7** “SKF solutions”, starting on **page 103**) can reduce unplanned breakdowns and improve reliability.

The following pages present the most important considerations and steps to remember during the design process (→ **table 1**, **page 11**). An example of the design process related to an electric motor is also included.

# 1 Rolling bearings in electric machines

## Design requirements

### Dimensions

In most cases, power output determines shaft size, and shaft size determines the bore diameter of the bearings. In recent years, however, the tendency has been to use bearings with smaller cross sections because they require less space.

### Loads

In order to select the best bearing for a particular application, all loads should be considered and not just the weights involved and the forces derived from the power transmitted. Be sure to include additional forces like the magnetic pull resulting from unsymmetrical air gaps, dynamic forces due to inaccurate adjustment, out-of-balance situations, pitch errors in gears, as well as any thrust loads.

Heavy loads are generally carried by roller bearings, where lighter loads are carried by ball bearings. Drive forces are considered only when belts or gears are utilized. Loads can be radial, axial or a combination of the two. Certain bearings, such as cylindrical roller bearings, usually carry radial loads only; where other bearings, such as angular contact ball bearings, are more suited for axial loads.

In order to provide satisfactory operation, ball or roller bearings must always be subjected to a given minimum load. Please refer to the relevant bearing type in the table section of the SKF General Catalogue.

Fig 1

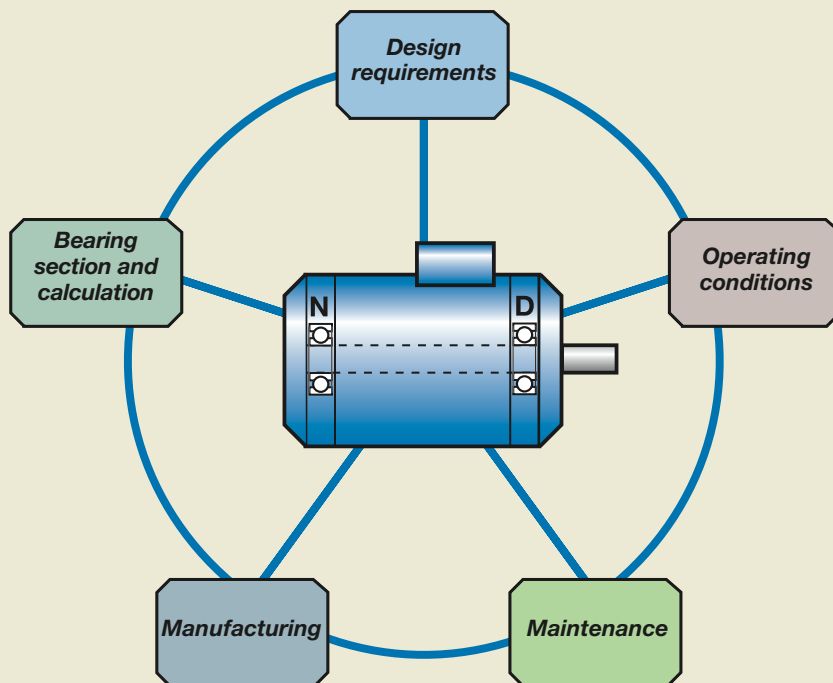

Parameters that have to be taken into consideration when designing an electric machine  
N = Non-drive end  
D = Drive end

# 1 Rolling bearings in electric machines

## Design requirements

Table 1	
<p><b>Design considerations and operating conditions</b></p> <ul style="list-style-type: none"> <li>• Boundary dimensions</li> <li>• Magnitude and direction of loads</li> <li>• Speed: fixed, variable or high</li> <li>• Shaft and housing material</li> <li>• Coupling, belt or gear drive</li> <li>• Horizontal or vertical mounting</li> <li>• Environment</li> <li>• Vibration level</li> <li>• Noise level</li> <li>• Temperature</li> <li>• Required bearing life</li> <li>• Lubrication: grease versus oil</li> <li>• Maintenance</li> <li>• Condition monitoring</li> </ul>	<p><b>Manufacturing</b></p> <ul style="list-style-type: none"> <li>• Product availability</li> <li>• Required precision</li> <li>• Handling and transportation</li> <li>• Mounting tools</li> </ul>

*Important parameters to consider when selecting the proper bearings for an electric motor or generator*

1

### Speed

Operating speed influences both bearing and lubricant life. Therefore, size, cage design, lubrication, clearance and seal type, must be considered when choosing the bearing.

#### Fixed speed

In an induction motor the number of poles determine the speed. For example, the maximum speed for a two-pole motor at 50 Hz is 3 000 r/min and at 60 Hz 3 600 r/min.

#### Variable speed

If the machine is to operate at different speeds during its duty cycle, all speed intervals should be taken into consideration when dimensioning the bearing and calculating bearing life.

Induction motors using frequency converters to vary their speed, require special consideration for bearing selection. Modern frequency converters using pulse width modulation (PWM) and fast switching semiconductor technology often run into problems with electrical erosion in bearings (→ **chapter 6** “Failure modes and corrective actions”, starting on **page 91**).

### High speed

Normally, ball bearings are more suitable for high-speed applications than roller bearings. In very high-speed applications, precision bearings or hybrid bearings may be beneficial. To make that determination, a thorough analysis of the dynamic performance of the machine would be necessary. Some of the factors that influence bearing service life at high speeds include the cage, lubricant, running accuracy and clearance of the bearings, the resonance frequency of the system, and the balancing of the rotating components.

### Shaft and housing material

Because materials expand and contract, it's important to take the coefficient of expansion into account when selecting shaft and housing materials. Thermal expansion (and contraction) can have a direct influence on shaft and housing fits as well as internal bearing clearance (→ **chapter 3** “Tolerances and fits”, starting on **page 51**).

# 1 Rolling bearings in electric machines

## Design requirements

### Coupling, belt and gear drives

The type of connector used between the drive and driven unit will influence the loads on the motor bearings.

There are two kinds of coupling drives: flexible and rigid. Good alignment is important in both cases, otherwise additional forces may be induced into the bearing system to reduce service life. Proper alignment is particularly important with a rigid coupling where there are typically three bearings on a shaft. When rigid couplings are aligned very accurately, by using laser-aligning equipment for instance, the drive end bearing might become relatively unloaded, the load being taken by the bearings on the non-drive end and the coupling shaft. In this case a deep groove ball bearing is recommended at the drive end.

A belt or gear drive will often load the motor bearings more heavily than a coupling drive. Belt and gear drives therefore most often use cylindrical roller bearings at the drive end. In applications where there are heavy loads and the possibility of misalignment and/or shaft deflection, a CARB toroidal roller bearing should be considered.

See also typical arrangements for coupling and belt drives in **chapter 2** “Bearing arrangements”, starting on **page 37**.

### Vertical mounting

Machines that are mounted vertically need special consideration, both when selecting the proper bearing arrangement (→ **chapter 2** “Bearing arrangements”, starting on **page 37**) and when calculating grease life (→ **chapter 4** “Lubrication and sealing”, starting on **page 59**). The mechanical stability of a grease is especially important for vertical shaft applications. Based on very good test results, SKF can recommend the LGHP 2 grease for vertical shafts.

Contact seals should be used, providing the best possible grease retention. As a rule of thumb, the relubrication interval should be halved for vertical shafts.

### Environment

Seals and shields should be used in damp and dusty environments to protect the bearings. Motors used in remote locations may also require seals and shields to create a low maintenance or maintenance-free variant. The type of seal or shield used will determine the maintenance requirements and the service life of the bearing. Different shield and seal options are discussed in **chapter 4** “Lubrication and sealing”, starting on **page 59**. To protect the bearings from damage caused by electric erosion (damage created by electric current flow through the bearing), insulated bearings are available from SKF (→ INSOCOAT bearings on **page 25** and hybrid bearings on **page 27**).

### Temperature

To properly select or design an electric machine it is important to know the ambient temperature range and the normal operating temperature of that machine. Knowing these temperature ranges will help determine the most effective cooling method: air, oil or water.

Normal operating temperatures for typical electric machines range from 70 to 110 °C. As a result, SKF recommends using a grease that has good performance properties over a wide range of temperatures. In applications where temperatures exceed 110 °C, high temperature greases are available from SKF (→ **chapter 4** “Lubrication and sealing”, starting on **page 59**).

In applications where ambient temperatures vary significantly from bearing operating temperature, a temperature gradient over the bearings can result. If the gradient is significant, check the resultant internal bearing clearance so as to avoid unnecessary bearing preload. SKF calculation tools can provide necessary information about clearance reduction caused by temperature gradients.



### Vibration

In environments where machinery is subjected to vibrations caused by an external source, it is generally recommended to use ball bearings when possible. Ball bearings, especially when preloaded with springs, are less sensitive to the damage caused by external vibrations. (→ **chapter 6** “Failure modes and corrective actions”, starting on **page 91**).

### Quiet running

Motors and generators are expected to run quietly. Therefore, it's important to select a bearing with the best combination of cage material, lubricant and internal clearance. SKF bearings already have very low noise levels. However, the levels can be further reduced by preloading the bearing arrangement with springs (→ section “Preloading with springs”, starting on **page 47**).

### Bearing life

The rated life of a rolling bearing is defined as the number of revolutions (or the number of operating hours at a given constant speed) the bearing could endure, before the first sign of fatigue (spalling or flaking) occurs on one of its rings or rolling elements.

Laboratory tests and practical experience, however, show that seemingly identical bearings operating under identical conditions have different lives.

The “service life” of a bearing depends, to a large extent, on its operating conditions. However, the procedures used to mount and maintain the bearing can also have a direct affect on its service life. Despite all the precautions, bearings can still fail prematurely. When this happens, the bearing should be examined carefully in order to determine the root cause of the failure. By doing so, corrective actions can then be taken.

The “specification life” is the life specified by the motor manufacturer and is based on hypothetical load and speed data. E.g. nominal life at maximum allowable load is 20 000 hours minimum.

Under specific operating conditions, SKF bearings can attain a much longer life than predicted by normal or traditional life calculation methods, particularly when loads are light. These

specific conditions prevail, when a lubricant film effectively separates the rolling surfaces (raceways and rolling elements) and when surface damage caused by contaminants is limited.

For appropriate calculation methods, please refer to SKF calculation tools, the SKF General Catalogue or the SKF Interactive Engineering Catalogue on CD-ROM or online at [www.skf.com](http://www.skf.com).

When selecting sealed for life bearings in electric machines, the service life most often will be limited by the grease life (→ **chapter 4** “Lubrication and sealing”, starting on **page 59**). Therefore, bearing service life and grease life need to be verified.

### Lubrication: grease versus oil

The choice between grease lubrication and oil lubrication is chiefly determined by the following factors:

- Grease should be used in applications where the following requirements apply:
  - Simplified maintenance
  - Improved cleanliness (fewer leaks)
  - Better protection against contaminants
- Oil lubrication should be used in applications where normal operating temperatures are high as a result of an external heat source or excess heat generated by the machine or its bearings at high speed.

**Note:** A temperature rise due to friction in the bearing, is generally lower with grease than with an oil bath, provided that the appropriate type and amount of grease is used and that it is supplied to the bearing in a suitable manner.

Oil lubrication should be used when the relubrication interval for grease is too short (→ **chapter 4** “Lubrication and sealing”, starting on **page 59**).

# 1 Rolling bearings in electric machines

## Design requirements

### Maintenance

Electric motor maintenance typically includes lubricating the bearings, servicing the stator windings and monitoring the performance of the motor.

For motors equipped with bearings that are sealed and lubricated for life, relubrication is not necessary and the motor is considered to be maintenance-free.

### Condition monitoring

Bearings in operation generate vibrations. With the methods and equipment available today, bearing condition can be effectively monitored and diagnosed. Suitable procedures for condition monitoring of electric motors are:

- Comparative measurements on a number of identical motors, running under the same operating conditions.
- Trend measurements on a motor at given intervals, to observe the change in bearing condition.

SKF has developed the tools and the knowledge base to effectively measure, trend, and diagnose bearing condition.

### Product availability

During the design stage, SKF recommends checking product availability with your local SKF representative. Up-to-date bearing data can be found in the SKF Interactive Engineering Catalogue online at [www.skf.com](http://www.skf.com).

### Handling, tools and transport

Rolling bearings are precision products, which must be handled carefully if they are to perform properly. When mounting or dismounting bearings it is important to use the correct methods and tools. Instructions can be found in **chapter 5** “Mounting and dismounting”, starting on **page 77**.

To prevent premature bearing failure, it is also important to prepare the motor properly for transport.

### Precision

The required accuracy of any machine determines the required precision of the bearings. Bearings with higher precision are available for high accuracy/high speed machinery. However, for a machine to benefit from the running accuracy of its bearings, its roundness and surface finish of the bearing seating must be machined accordingly.

## Bearing selection

Electric motors and generators use a wide variety of bearing types including deep groove ball bearings, angular contact ball bearings, cylindrical roller bearings, spherical roller bearings, CARB toroidal roller bearings and spherical roller thrust bearings.

In small horizontal machines, the most common arrangement consists of two deep groove ball bearings. In larger or heavier loaded machines, roller bearings are typically used.

In vertical machines deep groove ball bearings, angular contact ball bearings or spherical roller thrust bearings are typically used, depending on the loads, speeds, temperature and environment of the application.

As mentioned earlier, the design requirements and operating conditions of the application will influence the bearing arrangement. The bearings selected for the arrangement should be verified by calculating bearing life. A number of examples of bearing arrangements for electric machines are shown in **chapter 2** “Bearing arrangements”, starting on **page 37**.

### Bearing internal clearance

Bearing internal clearance is defined as the total distance through which one bearing ring can be moved relative to the other ring in the radial direction (radial internal clearance) or in the axial direction (axial internal clearance).

The internal clearance in ball bearings (not angular contact ball bearings), cylindrical, spherical and CARB toroidal roller bearings is always measured radially. A bearing initial clearance is chosen to accommodate:

- Expansion of the inner ring caused by its interference fit on the shaft.
- If applicable, compression of the outer ring caused by its interference fit in the housing.
- The reduction in radial clearance due to the temperature difference between the inner and outer ring during operation.
- The needed internal clearance during operation.

It is important to choose the right initial clearance, as insufficient operating

clearance can result in premature bearing failure.

For deep groove ball bearings radial clearance in electric machines is typically one class greater than Normal (suffix C3).

When bearing types other than deep groove ball bearings are used in high speed applications, (where speeds are 70 % or higher than the reference speed of the bearing) a C3 clearance should be selected. A C3 clearance should also be used when the temperature difference between the inner and outer rings exceeds 10 °C (15 °F). Increased clearances may also be necessary when an interference fit is needed for both bearing rings (usually cylindrical roller bearings).

The noise level of the bearing increases as internal radial clearance increases. Therefore, clearances should be chosen carefully.

If an application is designed to use a bearing with C3 clearance, do not use a bearing with Normal clearance. Bearings with Normal clearance have no clearance marking on the outer ring.

Tables for bearing internal clearance can be found in the SKF General Catalogue or the SKF Interactive Engineering Catalogue, available on CD-ROM or online at [www.skf.com](http://www.skf.com).

# 1 Rolling bearings in electric machines

## Bearing selection

### Correct preload

When selecting the preload force for a bearing arrangement it should be remembered that stiffness increases marginally when the preload exceeds a given optimum value and that the resulting friction and heat will decrease bearing service life substantially.

**Diagram 1** indicates the relationship between bearing service life and preload/clearance. In electric machines heat dissipation in the rotor or in the stator coils will strongly influence bearing clearance or preload. Because of the risk that an excessive preload implies for the operational reliability of a bearing arrangement, and because of the complexity of the calculations normally required to establish the appropriate preload force, it is advisable to consult the SKF application engineering service.

### Cages

Rolling bearings are available with a variety of cages and cage materials. Each is suited for different applications and operating conditions. Additional information about each cage type and material is presented in the discussion on bearing variants.

Diagram 1

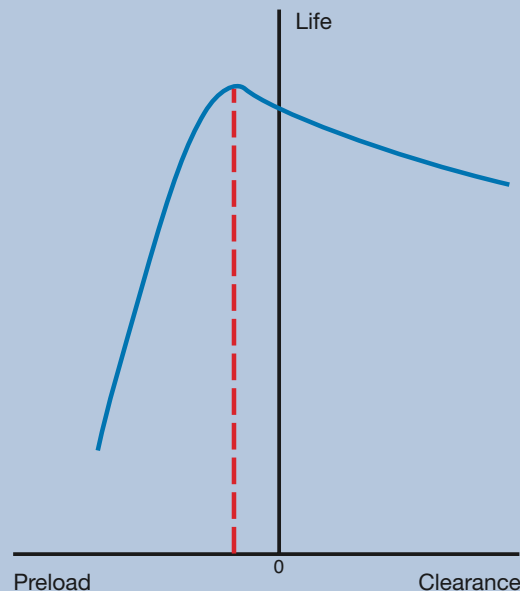

*Relationship between bearing life and preload/clearance*

## Calculation example

### Electric servomotor

Select bearings for a servomotor with a gear drive for horizontal mounting. The minimum required bearing life is 30 000 h. The shaft diameter needs to be 25 mm on the drive end and 20 mm on the non-drive end. Low maintenance is requested. Therefore, sealed bearings should be selected. It is crucial to choose high sealing efficiency, since the environment contains dust particles coming from a brake mounted near the non-drive end bearing (→ **fig 2**).

Use the SKF calculation tools or equations from the SKF General Catalogue. The calculation will give the basic rating life according to ISO,  $L_{10h}$ , and the SKF rating life  $L_{10mh}$ . The SKF rating life takes into account fatigue load limits, lubrication conditions and contamination levels. Since sealed bearings are greased for life, be sure to check that the service life of the grease in the bearings meets or exceeds the expected service life of the bearings in the motor. Be aware that motor life is often dependent on the life of the lubricant in greased-for-life electric motor bearings.

### Bearing selection

The most common bearing arrangement in electric motors uses two deep groove ball bearings, one at the drive end and one at the non-drive end. The bearing at the non-drive end is the locating bearing, and is designed to accommodate the axial load (→ **chapter 2** “Bearing arrangements”, starting on **page 37**). Choose a bearing clearance larger than normal, C3, assuming there is a temperature gradient in the bearing from heat generated in the rotor.

When selecting the lubricant for a sealed bearing, the simplest approach is to assume that the SKF standard grease will be adequate. It has a  $70 \text{ mm}^2/\text{s}$  viscosity at  $40 \text{ °C}$  ( $100 \text{ °F}$ ) and can operate between  $-30 \text{ °C}$  ( $-22 \text{ °F}$ ) and  $+110 \text{ °C}$  ( $+230 \text{ °F}$ ). To obtain efficient sealing, bearings with contact seals on both sides should be selected.

Fig 2

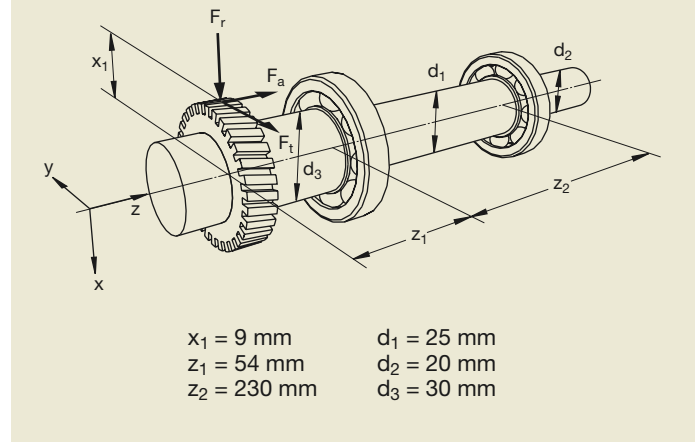

### Life calculations

Use the SKF rating life calculation to select the appropriate bearings for the application. When calculating bearing life for sealed bearings, the contamination factor  $\eta_c$  can generally be set at 0,8. Note: The values for bearings with Normal clearance should be used in this calculation since C3 clearance already accommodates thermal expansion of the shaft and loss of clearance due to the temperature gradient.

The life requirement is 30 000 h and the recommended static safety factor  $s_0 > 1$ .

### SKF rating life

Calculations are made according to the SKF calculation tools and equations

#### Given data

Gear forces	radial load	$F_r$	kN	dynamic	0,50	static	2,20
	tangential load	$F_t$	kN		1,25		5,45
	axial load	$F_a$	kN		0,55		2,40
Speed	$n$	r/min			3 000		
Operating temperature	$t$	°C			80		

#### Bearing load calculation

Drive end bearing	radial load	$F_r$	kN	dynamic	1,65	static	7,22
	axial load	$F_a$	kN		0		0
Non-drive end bearing	radial load	$F_r$	kN		0,31		1,35
	axial load	$F_a$	kN		0,55		2,40

# 1 Rolling bearings in electric machines

## Calculation example

from the SKF General Catalogue. Results are found in the table “Calculation results”.

For the drive end, the rating life of 25 150 h for an SKF Explorer 6205-2RSH/C3 bearing is insufficient. Therefore, an SKF Explorer 6305-2RS1/C3 is selected, indicating a rating life of 236 600 h.

For the non-drive end, the rating life of 116 900 h for an SKF Explorer 6204-2RSH/C3 bearing is more than sufficient.

### Grease life

Grease life calculations are made according to the method described in the section “Grease life in sealed bearings” on **pages 70 and 71**.

Drive end bearing: 6305-2RS1/C3.

The following values are determined

- From **diagram 4**, **page 70**, the grease life for load conditions  $C/P = 15$ . With  $GPF = 1$ , operating temperature  $t = 80\text{ °C}$  and  $n \times d_m$  value 130 500, the grease life value of 23 000 h is obtained.
- From **table 7**, **page 71**, the reduction factor for increased loads. With  $C/P = 14,18$ , a correction factor of 0,95 is obtained.

Therefore grease life is  $23\ 000 \times 0,95 = 21\ 850\text{ h}$ .

Non-drive end bearing: 6204-2RSH/C3.

The following values are determined

- From **diagram 4**, **page 70**, the grease life for load conditions  $C/P = 15$ . With  $GPF = 1$ , operating temperature  $t = 80\text{ °C}$  and  $n \times d_m$  value 100 500, the grease life value of 29 500 h is obtained.
- From **table 7**, **page 71**, the reduction factor for increased loads. With  $C/P = 13,1$ , a correction factor of 0,88 is obtained.

Therefore grease life is  $29\ 500 \times 0,88 = 25\ 900\text{ h}$ .

### Further considerations

The calculations result in more than adequate SKF rating life for both bearings. However the grease life is the limiting factor.

Therefore alternative calculations can be made for the same bearings with a grease specifically formulated for difficult applications like electric motors,

suffix GJN and WT. The result of these calculations is found in the table “Calculation results”.

Both SKF Explorer bearings with a GJN or WT grease fulfill the requirements.

### Conclusion

Using sealed bearings with a standard grease fill in this application does not result in the required 30 000 h rating life due to the insufficient grease life. By using the same bearings, but with specific greases for electric motors, suffix GJN or WT, requirements are met.

The use of SKF Explorer bearings offers a further very interesting possibility: Downsizing. Both bearings can be downsized. Calculations with

- an SKF Explorer 6205-2RSH/C3 bearing at the drive end
- an SKF Explorer 6004-2RSH/C3 bearing at the non-drive end
- both bearings with a specific electric motor grease fill, suffix GJN or WT,

also fulfill the requirements (→ results in the table “Calculation results – Downsizing”).

Bearings in the 62 and 63 series are typically used in electric motors. However, from the calculations above it stands clear that when electric motor designers want to downsize they can achieve this by using SKF Explorer bearings with the right grease selection. Downsizing can result in not only a smaller footprint of the motor but also material savings as the width of the motor shields can be reduced.

# 1 Rolling bearings in electric machines

## Calculation example

Calculation results			Drive end			Non-drive end		
Bearings			6305-2RS1/C3	6305-2RS1/C3GJN	6305-2RS1/C3WT	6204-2RSH/C3	6204-2RSH/C3GJN	6204-2RSH/C3WT
<b>Dynamic conditions</b>								
Equivalent bearing load	P	kN	1,65	1,65	1,65	1,03	1,03	1,03
Dynamic carrying capacity	C	kN	23,4	23,4	23,4	13,5	13,5	13,5
C/P			14,18	14,18	14,18	13,1	13,1	13,1
Basic rating life	$L_{10}$	$10^6$	2 852	2 852	2 852	2 252	2 252	2 252
Basic rating life	$L_{10h}$	h	15 840	15 840	15 840	12 509	12 509	12 509
Fatigue load limit	$P_u$	kN	0,49	0,49	0,49	0,28	0,28	0,28
Contamination factor	$\eta_c$		0,8	0,8	0,8	0,8	0,8	0,8
$P_u/P \times \eta_c$			0,237	0,237	0,237	0,218	0,218	0,218
Bearing mean diameter	$d_m$	mm	43,5	43,5	43,5	33,5	33,5	33,5
$n \times d_m$		mm/min	130 500	130 500	130 500	100 500	100 500	100 500
Required viscosity	$v_1$	$mm^2/s$	10,5	10,5	10,5	11,9	11,9	11,9
Grease viscosity at 80° C	$v$	$mm^2/s$	12,9	21,7	15,8	12,9	21,7	15,8
Kappa value	$\kappa$		1,23	2,07	1,51	1,08	1,82	1,32
Life modification factor	$a_{SKF}$		14,9	40,5	22,8	9,35	25,8	14,3
<b>SKF rating life</b>	<b><math>L_{10mh}</math></b>	<b>h</b>	<b>236 600</b>	<b>641 400</b>	<b>361 100</b>	<b>116 900</b>	<b>322 200</b>	<b>179 200</b>
<b>Static conditions</b>								
Equivalent bearing load	$P_0$	kN	7,22	7,22	7,22	2,01	2,01	2,01
Static carrying capacity	$C_0$	kN	11,6	11,6	11,6	6,55	6,55	6,55
<b>Static safety factor</b>	<b><math>s_0</math></b>		<b>1,61</b>	<b>1,61</b>	<b>1,61</b>	<b>3,26</b>	<b>3,26</b>	<b>3,26</b>
<b>Lubrication</b>								
Value from diagram	$L_{10h}$	h	23 000	48 000	80 000	29 500	57 000	90 000
Load correction factor			0,95	0,95	0,95	0,88	0,88	0,88
<b>Grease life</b>	<b><math>L_{10h}</math></b>	<b>h</b>	<b>21 850</b>	<b>45 600</b>	<b>76 000</b>	<b>25 900</b>	<b>50 100</b>	<b>79 200</b>

Calculation results – Downsizing			Drive end			Non-drive end		
Bearings			6205-2RSH/C3	6205-2RSH/C3GJN	6205-2RSH/C3WT	6004-2RSH/C3	6004-2RSH/C3GJN	6004-2RSH/C3WT
<b>Dynamic conditions</b>								
Equivalent bearing load	P	kN	1,65	1,65	1,65	0,955	0,955	0,955
Dynamic carrying capacity	C	kN	14,8	14,8	14,8	9,95	9,95	9,95
C/P			8,97	8,97	8,97	10,42	10,42	10,42
Basic rating life	$L_{10}$	$10^6$	722	722	722	1131	1131	1131
Basic rating life	$L_{10h}$	h	4 009	4 009	4 009	6 283	6 283	6 283
Fatigue load limit	$P_u$	kN	0,335	0,335	0,335	0,212	0,212	0,212
Contamination factor	$\eta_c$		0,8	0,8	0,8	0,8	0,8	0,8
$P_u/P \times \eta_c$			0,162	0,162	0,162	0,178	0,178	0,178
Bearing mean diameter	$d_m$	mm	38,5	38,5	38,5	31	31	31
$n \times d_m$		mm/min	115 500	115 500	115 500	93 000	93 000	93 000
Required viscosity	$v_1$	$mm^2/s$	11,1	11,1	11,1	12,4	12,4	12,4
Grease viscosity at 80° C	$v$	$mm^2/s$	12,9	21,7	15,8	12,9	21,7	15,8
Kappa value	$\kappa$		1,16	1,95	1,42	1,04	1,75	1,27
Life modification factor	$a_{SKF}$		6,28	14,4	8,93	5,95	15	8,79
<b>SKF rating life</b>	<b><math>L_{10mh}</math></b>	<b>h</b>	<b>25 150</b>	<b>57 700</b>	<b>35 800</b>	<b>37 400</b>	<b>94 150</b>	<b>55 200</b>
<b>Static conditions</b>								
Equivalent bearing load	$P_0$	kN	7,22	7,22	7,22	2,01	2,01	2,01
Static carrying capacity	$C_0$	kN	7,80	7,80	7,80	5,0	5,0	5,0
<b>Static safety factor</b>	<b><math>s_0</math></b>		<b>1,08</b>	<b>1,08</b>	<b>1,08</b>	<b>2,49</b>	<b>2,49</b>	<b>2,49</b>
<b>Lubrication</b>								
Value from diagram	$L_{10h}$	h	27 500	52 000	85 000	30 000	60 000	95 000
Load correction factor			0,6	0,6	0,6	0,70	0,70	0,70
<b>Grease life</b>	<b><math>L_{10h}</math></b>	<b>h</b>	<b>16 500</b>	<b>31 200</b>	<b>51 000</b>	<b>21 000</b>	<b>42 000</b>	<b>66 500</b>

1 Rolling bearings in electric machines  
Deep groove ball bearings





## Deep groove ball bearings

Deep groove ball bearings are most typically found in both the locating and non-locating positions of small to medium sized electric motors and in the locating position of medium to large sized electric motors and generators. Quiet running is one of the most important advantages of the deep groove ball bearing over other types of rolling element bearings. A varied assortment and economical price levels also make deep groove ball bearings very popular.

### Features and benefits of SKF deep groove ball bearings

Along with quiet running, low cost and a varied assortment, there are many other features that make deep groove ball bearings a common choice for electric motors. Deep groove ball bearings have low friction and high-speed capability. They can carry radial, axial and combined loads, making them suitable for use in both the locating and non-locating positions of the motor. Axial springs can be used with non-locating deep groove ball bearings to further reduce noise and vibration levels.

Deep groove ball bearings with seals or shields on both sides are lubricated for life and require no maintenance.

Benefits of SKF deep groove ball bearings include:

- A large range of greased-for-life bearings.
- A variety of greases including an ultra quiet SKF standard grease, as well as food grade greases for food, pharmaceutical and medical applications and in particular wide temperature greases that contribute to longer grease life.
- Low friction and reduced sensitivity to misalignment.
- Highly efficient sealing options including contact seals, low friction seals and shields.

For high performance electric motors (e.g. frequency inverter fed motors), SKF has developed a specific range of shielded and sealed bearings prefilled with a high performance wide temperature grease (designation suffix WT). This

grease, based on a polyurea thickener with an ester base oil, can be used in applications where temperatures range from  $-40\text{ }^{\circ}\text{C}$  to  $+160\text{ }^{\circ}\text{C}$  ( $-40\text{ }^{\circ}\text{F}$  to  $+320\text{ }^{\circ}\text{F}$ ) (→ **table 1** on **page 62**).

Other greases for specific environments (e.g. food, pharmaceutical and medical applications) and extreme temperature conditions (e.g. ovens, smoke extraction motors) can also be supplied on demand. Please consult the SKF application engineering service.

### SKF Explorer deep groove ball bearings – the high performance class

With the SKF Explorer performance class of deep groove ball bearings, SKF goes even further by allowing all customers to benefit from solutions developed for advanced applications. Typical examples of SKF Explorer features are:

- Optimized internal geometry and rolling contact surface
- Upgraded ball quality
- ISO class P6 for dimensional accuracy and closer tolerances on width deviation
- Depending on sizes, running accuracy up to 2 classes better than Normal
- High cleanliness steel

Such features provide SKF Explorer deep groove ball bearings with substantial improvement in accuracy, which results in superior performance in quiet running and speed capability. It also results in longer service life.

1 Rolling bearings in electric machines  
Cylindrical roller bearings



## Cylindrical roller bearings

Cylindrical roller bearings are typically used in belt or gear driven medium to large sized electric motors, where heavy radial loads prevail. These bearings are usually used in the non-locating drive side position, in combination with a deep groove ball bearing. Common types of cylindrical roller bearing are the N and NU series having one double flanged ring carrying the roller and cage assembly; the other ring has no flanges, to allow free displacement relative to the other ring (→ fig 3). Other types of cylindrical roller bearings, such as the NJ and NUP series, have one double flanged outer ring carrying the roller and cage assembly, the inner ring has one or two flanges that can accommodate light axial loads in one or both directions (→ fig 4). These are routinely used in vibratory motors.

### Advantages

Cylindrical roller bearings have high radial load carrying capability as well as relatively high-speed capability. The separable component design of the cylindrical roller bearing simplifies mounting. Bearings in the N and NU series accommodate axial movement inside the bearing, enabling tight shaft and housing fits, even for bearings in the non-locating position.

### Options

The range of cylindrical roller bearing configurations is large compared with other bearing types. The various flange configurations (NU, NJ, NU and N designs) make the bearings suitable for a multitude of applications. Cylindrical roller bearings are available with a choice of different cages. Small bearings have a polyamide cage as standard (designation suffix P). These cages have low friction, are elastic and have good sliding properties. Medium-sized bearings have a window-type steel cage as standard (designation suffix J). These cages withstand high temperatures and also medium to strong vibrations. Large bearings have a brass cage as standard. These cages can withstand high speeds and can cope with vibrations and accelerations.

### Internal clearance

Normal internal radial clearance is greater in a cylindrical roller bearing than a deep groove ball bearing. As a result, unless there are special shaft and housing fit requirements, Normal clearance (CN) is preferred over C3 clearance for cylindrical roller bearings used in electric motors and generators. With a normal fit, the rollers should be sufficiently loaded to reduce noise and the risk of smearing.

### SKF Explorer cylindrical roller bearings – the high performance class

Developments in the areas of steel production, heat treatment, manufacturing and design have considerably increased the performance of SKF cylindrical roller bearings. The advantages given by SKF Explorer bearings are:

- Increased loading capacity
- More compact machine designs by using smaller bearings
- Increased service life and higher reliability of existing machines
- Quieter running

SKF Explorer bearings retain the designations of earlier standard bearings. However, each bearing and its box is marked with the name Explorer.

NU design

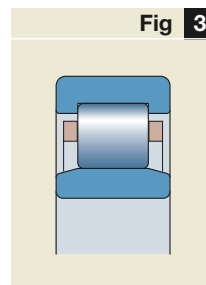

NJ design

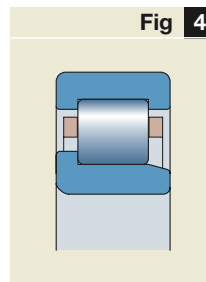

1 Rolling bearings in electric machines  
INSOCOAT bearings



## **INSOCOAT<sup>®</sup> bearings**

SKF provides electrically insulated bearings, called INSOCOAT, to protect against the damage caused by electric currents. Insulated bearings are generally mounted on the non-drive end of converter driven induction motors and at both bearing locations in large generators, such as in wind energy production.

Insocoat bearings are available with an insulating coating on either the outer ring (designation suffix VL0241) or the inner ring (designation suffix VL2071)

An outer ring coating can be applied to bearings with an outside diameter above and including 80 mm. An inner ring coating can be applied to bearings with a bore diameter above and including 70 mm. The aluminium oxide coating is applied to the bearing surface by a unique plasma-spraying technology.

In principle, any bearing type can be electrically insulated. The standard INSOCOAT bearing types include deep groove ball bearings and cylindrical roller bearings.

Fits can be applied up to and including p6 for inner ring coated bearings and up to and including P6 for outer ring coated bearings. INSOCOAT bearings can therefore use the same fit, as a standard bearing in the same application.

SKF performs 100 % testing at a breakdown voltage larger than 1 000 V DC. Lab tests show that electrical breakdown occurs above 3 000 V DC.

INSOCOAT bearings have a minimum ohmic resistance of 50 MΩ.

### **Advantages**

INSOCOAT bearings

- provide two features in one solution: a bearing function and electrical insulation function,
- virtually eliminates arcing related failures to improve uptime,
- reduce maintenance costs,
- are cost effective when compared with other solutions to electrical erosion (electric current damage in bearings),
- have global availability by virtue of the SKF presence in more than 130 countries and at 7 000 distribution locations worldwide.

### **Customer benefits**

- Outstanding coating quality and adherence.
- High performance in humid environments. The coating is insensitive to heat and chemicals.
- INSOCOAT bearings provide better electrical protection and mechanical performance than other insulation methods.
- Simple mounting and dismounting. INSOCOAT bearings should be handled with the same care as standard bearings.
- Large range available on stock.
- Standard boundary dimensions according to ISO.
- Environmentally friendly.
- SKF has more than 20 years experience with ceramic coatings.
- Coating the inner ring of a bearing enhances the protection against electric current damage; particularly in applications where damage is caused by high frequency currents.

**1 Rolling bearings in electric machines**  
Hybrid bearings



## Hybrid bearings

Hybrid bearings have rings made from bearing steel and rolling elements made from bearing grade silicon nitride.

Silicon nitride is a low density, high strength ceramic material that has a high degree of toughness and hardness and also has excellent insulating properties.

When used as an insulator, the ceramic rolling elements in a hybrid bearing prevent damaging electric currents from passing through the bearing. This is one of the main reasons for using hybrid bearings in electric motors and generators (→ **chapter 6** “Failure modes and corrective actions”, starting on **page 91**).

High speed electric motors use hybrid bearings because they provide substantially longer service life and lower friction than traditional all-steel bearings.

### Advantages

- **Prevent passage of electrical current**

Silicon nitride is an electric insulator.

- **Ability to run at higher speeds**

- Lower density: Silicon nitride balls have a density of only 40 % of similarly sized steel balls. This means higher speeds, less weight, lower inertia, more rapid starts and stops.

- Low friction: Silicon nitride’s low coefficient of friction enhances wear resistance enabling the bearing to run cooler even under poor lubrication conditions. This means better lubrication, less noise, lower operating temperatures.

- Higher modulus of elasticity: Ceramic rolling elements have a 50 % higher modulus of elasticity than steel. This means increased bearing stiffness.

- Lower coefficient of thermal expansion: Ceramic rolling elements have a thermal expansion only 29 % of similar steel rolling elements. This means less sensitivity to temperature gradients for more accurate preload control.

- **Improve service life**

Hybrid bearings can improve the service life of those applications where poor lubrication is caused by any of the following conditions:

- High temperatures
- Vertical shaft or outer ring rotation
- Air streams

Silicon nitride and steel is an excellent combination of materials. The friction coefficient between silicon nitride and steel is lower than steel-on-steel for a dry sliding contact. The adhesion between silicon nitride and steel is low, micro welding does not occur and there is no risk of smearing. As a result, hybrid bearings can run at lower temperatures even with a very thin lubricant film.

- **Improve grease life**

Hybrid bearings generate less friction and less heat than comparably sized all-steel bearings. The resulting lower temperatures improve grease life so that grease can last 3 to 5 times longer depending on the application and operating conditions.

- **Resist wear caused by solid particle contamination**

Silicon nitride is very hard, harder than most particles that can occur as contaminants in a bearing. The silicon nitride rolling elements eliminate the particles either by crushing them or pressing them into the (softer) steel rings, where they are rendered harmless.

- **Resist vibration**

Silicon nitride rolling elements on steel have much higher resistance against wear caused by small vibrations within the bearings, particularly at a standstill.

1 Rolling bearings in electric machines  
Angular contact ball bearings





## **Angular contact ball bearings**

Angular contact ball bearings are used primarily as locating bearings in vertical electric motors when heavy axial loads cannot be accommodated by deep groove ball bearings. Available in either a single or double row design, angular contact ball bearings have a high axial load carrying capacity as well as high speed capability.

A double row angular contact ball bearing or a pair of universally matched single row angular contact ball bearings can also accommodate heavier radial loads.

### **Features and benefits**

The ability to accommodate heavy axial loads and high speeds make angular contact ball bearings an excellent choice for some electric motor applications.

#### **Single row angular contact ball bearings**

Depending on their size, single row angular contact ball bearings are available with a new improved design of glass fibre reinforced polyamide 6,6 and machined or pressed brass cages. For most popular sizes, SKF manufactures as standard universally matchable bearings which provide a very controlled clearance or preload when the bearings are mounted back-to-back, face-to-face or in tandem (→ the SKF General Catalogue for clearance and preload charts).

#### **High-precision single row angular contact ball bearings**

These bearings, which are manufactured to different high-precision classes, are available with a phenolic cage and either steel or ceramic balls. There is a choice of two contact angles and three preload levels and in some instances sealed bearings are also available. These bearings are typically used in very high-speed applications, such as spindle motors.

#### **Double row angular contact ball bearings**

With or without seals or shields, double row angular contact ball bearings are produced to both Normal and C3 internal axial clearance. Depending on

their size, these bearings are available with a glass fibre reinforced polyamide 6,6 and a pressed steel crown cage.

### **SKF Explorer angular contact ball bearings – the high performance class**

SKF is continuously working to improve the performance and durability of its products. And with the new SKF Explorer angular contact ball bearings, we think you will notice the difference immediately. These bearings can provide:

- Even longer service life
- Even higher reliability
- Even more performance

There are many factors adding up to this new performance class, including:

- Improved materials
- Optimized internal geometry
- Higher precision
- New heat treatment
- Higher ball quality
- Improved cages
- Manufactured for universal matching as standard
- New shields for double row bearings

SKF Explorer angular contact ball bearings are not an extension of the assortment. They replace final variants of the previous types. And because it is easier for inventory management, their part numbers remain the same. Nevertheless, SKF Explorer bearings can be recognized easily.

SKF Explorer bearings come in a unique package, so that they can be recognized immediately as SKF Explorer bearings.

1 Rolling bearings in electric machines  
Spherical roller bearings



## Spherical roller bearings

Spherical roller bearings are commonly used in large, oil lubricated electric motors and generators (→ section “Large and very large electric machines” on **page 109**), and also in vibrating applications like shaker screens. Spherical roller bearings are also found in large motors and generators that use plunger block housings.

### Advantages

SKF spherical roller bearings have extremely high load-carrying capabilities. They are equipped with special features such as self-guiding rollers (an SKF patent) that enable them to generate less heat during operation. The bearings are self-aligning and consequently insensitive to misalignment. The misalignment capability depends on the bearing series. SKF spherical roller bearings are available with either a cylindrical or tapered bore and can be mounted in special housings designed for large motors and generators (→ section “SKF flanged housing units with rolling bearings” on **page 109**) Spherical roller bearings designed for vibrating applications are also available.

SKF also has a range of sealed spherical roller bearings (with and without relubrication holes in the outer ring), which can significantly simplify the sealing arrangement.

### Internal clearance

Normal internal radial clearance is greater in a spherical roller bearing than in a deep groove ball bearing. As a result, unless there are special shaft and housing fit requirements, Normal clearance (CN) is preferred over C3 clearance for spherical roller bearings used in electric machines. With a Normal (CN) clearance and a normal fit, the rollers should be sufficiently loaded to reduce noise and the risk of smearing.

### SKF Explorer spherical roller bearings – the high performance class

Over the years, manufacturing and materials research and process improvements have enabled machine components to get smaller without decreasing power output. With each

developmental milestone, engineers were given a choice: Either downsize the application or increase power output. The SKF Explorer spherical roller bearings represent the next significant improvement in performance. But this is not just a short step to the next level. This is a quantum leap in bearing performance. Tests have shown that these spherical roller bearings can last up to three times longer than other bearings.

The longer bearing service life of SKF Explorer spherical roller bearings opens up a new world of possibilities. If you size-down with an SKF Explorer spherical roller bearing, not only will you be able to reduce noise, vibration and warranty costs, but you will also be able to build additional value in each component by increasing speed, improving service intervals, reducing heat and power consumption and controlling your customer’s maintenance costs.

SKF is continuously working to improve the performance and durability of its products. And with the new SKF Explorer spherical roller bearings, we think you will notice the difference immediately. These bearings can provide:

- Even longer service life
- Even higher reliability
- Even more performance

1 Rolling bearings in electric machines  
CARB toroidal roller bearings



## CARB<sup>®</sup> toroidal roller bearings

The CARB toroidal roller bearing can support very heavy radial loads. It is intended exclusively as a non-locating bearing and as such is an excellent choice with its combination of self-aligning and axial alignment properties. The rollers of the CARB bearing are self-guiding and will always adopt the position where the load is evenly distributed over the roller length – irrespective of whether the inner ring is axially displaced and/or misaligned with respect to the outer ring. The CARB bearing adapts to both angular misalignment and axial displacement simultaneously. Because it tolerates more than any other bearing, it can extend service life, increase uptime and reduce maintenance costs where conventional bearings might experience premature failure.

### Advantages

CARB bearings are used in small, medium and large electric motors and generators as the non-locating bearing to accommodate axial expansion of the shaft. In belt and geared motors, the CARB bearing also accommodates heavy radial loads. The CARB bearing is unique in its design as it can accommodate axial expansion of the shaft internally like a cylindrical roller bearing and misalignment like a spherical roller bearing. In addition, the CARB bearing has high load carrying capability, low friction and where needed a compact cross section like a needle roller bearing. The special design of the rollers also allows the CARB bearing to be lightly loaded without the potential for skidding, making it possible for this bearing to be used in coupled motors with relatively light loads.

### Misalignment and axial displacement

CARB bearings can accommodate up to 0,5 degrees of misalignment without affecting bearing performance. Axial displacement capability is a function of the radial clearance in the bearing and the misalignment between the inner and outer rings.

### Internal clearance

The internal radial clearance of a CARB bearing is greater than the clearance levels for comparable spherical roller bearings and cylindrical roller bearings having the same clearance class. This is because the axial displacement of one ring in relation to the other will reduce the radial clearance in CARB bearings. Since the levels are higher than those corresponding to other rolling bearings, the preferred clearance level for CARB bearings in electric motors and generators is Normal clearance.

### SKF Explorer CARB toroidal roller bearings – the high performance class

SKF Explorer CARB bearings represent the the next significant improvement in performance.

The longer bearing service life of SKF Explorer CARB toroidal roller bearings opens up a new world of possibilities. If you size-down with an SKF Explorer bearing, not only will you be able to reduce noise, vibration and warranty costs, but you will also be able to build additional value into each component by increasing speed, improving service intervals, reducing heat and power consumption and controlling your customer's maintenance costs.

SKF is continuously working to improve the performance and durability of its products. And with the new SKF Explorer CARB toroidal roller bearings, we think you will notice the difference immediately. These bearings can provide:

- Even longer service life
- Even higher reliability
- Even more performance

1 Rolling bearings in electric machines  
Spherical roller thrust bearings



## Spherical roller thrust bearings

In a spherical roller thrust bearing, the load is transmitted from one raceway to the other at an angle to the bearing axis. This enables the bearing to accommodate radial loads in addition to simultaneously acting axial loads. Another important feature of a spherical roller thrust bearing is the self-aligning capability, which makes the bearing tolerant of shaft deflections and misalignment. Spherical roller thrust bearings can be used as a replacement for hydrostatic or hydrodynamic bearings.

### Advantages

Spherical roller thrust bearings can accommodate heavy axial loads, radial loads and relatively high speeds even under misalignment. These advantages make spherical roller thrust bearings an excellent choice for use in vertical motors. Furthermore, their separable component design simplifies mounting.

The ability to maximize the effects of an oil bath by creating an internal pumping action makes spherical roller thrust bearings a very cost-effective choice when compared to hydrostatic bearings that require an oil pressure system. Grease lubrication is also possible in low speed applications.

Due to the self-aligning capability of spherical roller thrust bearings, their full load carrying capacity can be utilized even when the bearing washers are slightly out of alignment. The even distribution of load is still maintained should there be small angular misalignments of the seating surfaces.

### SKF Explorer spherical roller thrust bearings – the high performance class

Over the years, manufacturing and materials research and process improvements have enabled machine components to get smaller without decreasing power output. With each developmental milestone, engineers were given a choice: Either downsize the application or increase power output. The SKF Explorer spherical roller thrust bearings represent the next significant improvement in performance. But this is not just a short step to the next level. This is a quantum leap in

bearing performance. Tests have shown that these spherical roller thrust bearings can last up to three times longer than other bearings.

The longer bearing service life of SKF Explorer spherical roller thrust bearings opens up a new world of possibilities. If you size-down with an SKF Explorer bearing, not only will you be able to reduce noise, vibration and warranty costs, but you will also be able to build additional value into each component by increasing speed, improving service intervals, reducing heat and power consumption and controlling your customer's maintenance costs.

SKF is continuously working to improve the performance and durability of its products. And with the new SKF Explorer spherical roller thrust bearings, we think you will notice the difference immediately. These bearings can provide:

- Even longer service life
- Even higher reliability
- Even more performance

## 2 Bearing arrangements

Selecting a bearing arrangement ..... 37

Preloading with springs ..... 47

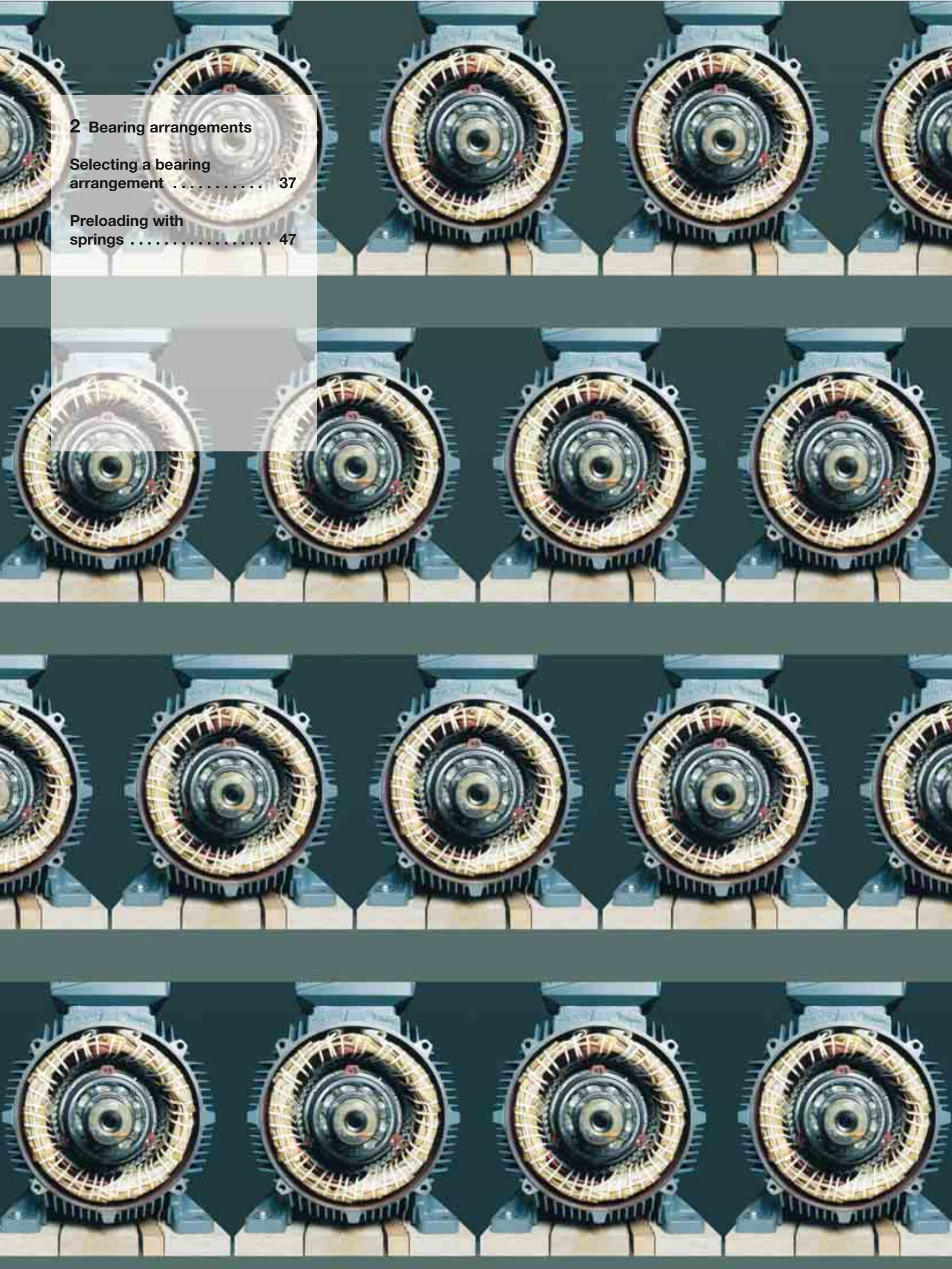



# Bearing arrangements

Bearings in electric motors and generators must support the rotor radially and locate it axially in relation to the stator. To do this, most bearing arrangements use a locating bearing and a non-locating bearing.

In most medium and large motors and generators, the locating bearing is a deep groove ball bearing while the non-locating bearing is typically a ball bearing, a cylindrical roller bearing or a CARB bearing. Smaller motors, fitted with two deep groove ball bearings mounted on a short shaft often have a cross-locating bearing arrangement.

## Selecting a bearing arrangement

Most motors are designed with a locating and non-locating bearing arrangement. The locating bearing positions the shaft and supports axial loads. The non-locating bearing is designed to accommodate thermal expansion of the shaft, otherwise excessive axial forces could be induced on the bearing arrangement. Some bearing types, such as a deep groove ball bearings, can be used in both the locating and non-locating position. Other bearing types are either locating, such as angular contact ball bearings, or non-locating, such as most cylindrical roller bearings.

When a deep groove ball bearing is used in the non-locating position, the outer ring must be able to move axially to accommodate thermal shaft expansion. This requires a loose fit on the bearing outer ring (→ **fig 1**, **page 38**). If a cylindrical roller bearing or a CARB toroidal bearing were used in the non-locating position, axial expansion would be accommodated within the bearing; therefore, a tight fit in the housing and the shaft can be applied beneficially.

## 2 Bearing arrangements

### Selecting a bearing arrangement

Electric motors intended for belt drives can use either a cylindrical roller bearing or a CARB toroidal roller bearing in the non-locating position.

Different application requirements need to be considered when designing an electric motor, such as service life, noise levels and maintenance. Sometimes the requirements are such that a compromise may be necessary. For example, if an application has high operating temperatures, it may not be possible to use greased-for-life bearings that have seals or shields. Instead, relubrication features may be necessary.

### Arrangements for coupling drives

#### Small motors

Small motors generally use a cross-locating arrangement with two deep groove ball bearings. Each bearing locates the shaft axially in one direction only and in opposite directions. To meet low noise requirements, deep groove ball bearings are usually preloaded with springs (→ fig 2). The axial load from the springs provides the minimum

load requirements for the bearing. The springs also centre and guide the rotor to reduce vibrations and noise for a quieter running motor.

The typical small motor housing uses a gap type seal. For additional protection, the bearings are equipped with low friction shields and are greased for life. This type of seal arrangement is suitable for dry, clean environments. For more contaminated environments a low friction rubber seal is recommended.

#### Medium to large motors

The typical bearing arrangement in a medium or large motor uses two deep groove ball bearings where the bearing on the drive end is the locating bearing and the bearing on the non-drive end is the non-locating bearing. When a deep groove ball bearing is used in the non-locating position, the outer ring must be able to move axially to accommodate thermal expansion of the shaft. This requires a loose fit in the housing.

Medium and large electric motors are usually equipped with open bearings that require relubrication. If the bearings need frequent relubrication,

Fig 1

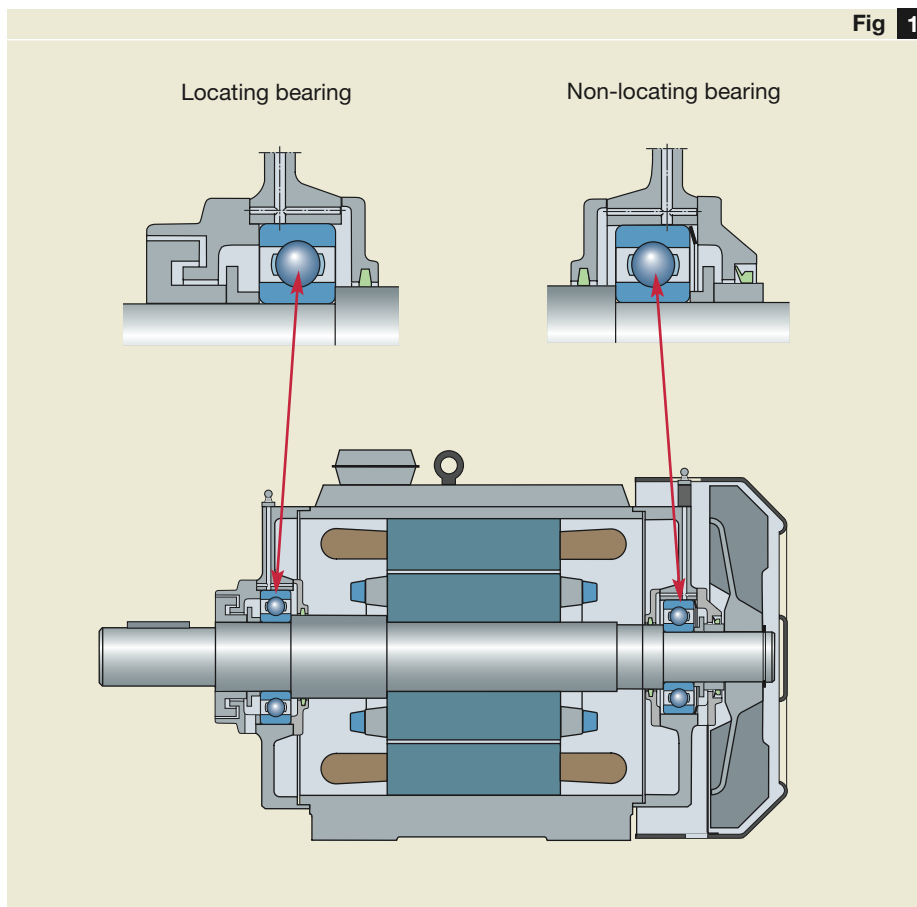

*Medium-sized  
three phase  
electric motor  
with relubrication  
devices and grease  
escape valves*

## 2 Bearing arrangements

### Selecting a bearing arrangement

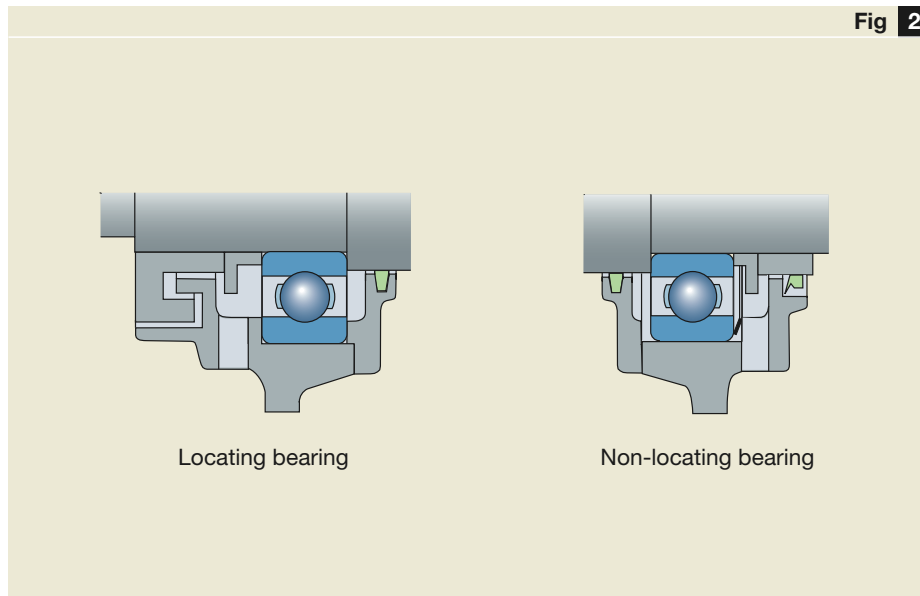

Locating and non-locating bearings

the motor should be equipped with grease escape valves (→ figs 1, 2 and chapter 4 “Lubrication and sealing”, starting on page 59). Excess grease is collected by a rotating disc, discharged into a cavity in the end-cover by centrifugal force, and ejected through an opening in the underside of the cover.

To seal the bearing arrangement, a labyrinth seal is used at the drive end and a V-ring at the non-drive end. Felt seals are used on the inner covers to prevent grease from leaking into the rotor area.

### Arrangements for belt drives

#### Small motors

Small motors, up to a frame size of 132, are usually equipped with two deep groove ball bearings (→ “Arrangements for coupling drives – Small motors”, above).

#### Medium to large motors

Electric motors intended for belt drives can use either a cylindrical roller bearing or a CARB toroidal roller bearing in the non-locating position.

Either of these bearings will accommodate the radial loads caused by belt tension and thermal shaft expansion. Because both the CARB and cylindrical roller bearings accommodate axial expansion internally, the bearings need to be located axially. Note that an interference fit is not sufficient to secure a bearing ring axially.

### Aluminium housings

The coefficient of expansion for aluminium is more than two times greater than for cast iron or steel. Therefore, for motors with aluminium housings, steps should be taken to prevent the outer ring from rotating on its seating. This usually happens to the non-locating bearing because it often has a loose fit in the housing. It can also happen in applications where the direction of load is indeterminate.

To prevent the outer ring from moving, an O-ring groove can be cut into the bearing seating, and a rubber O-ring installed. When designed correctly, the O-ring will apply enough pressure to the outer ring that it will be unable to spin in the bore (→ fig 3, page 40).

## 2 Bearing arrangements

### Selecting a bearing arrangement

Fig 3

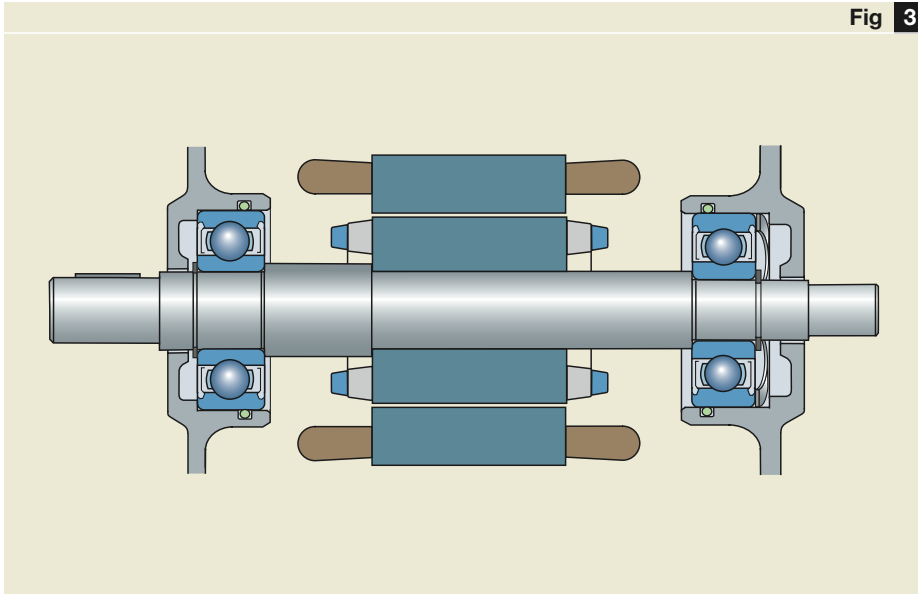

Arrangement with aluminium housings equipped with O-rings to prevent outer ring rotation

#### Design rules

To prevent the bearing from shearing the O-ring during installation, the O-ring groove needs to be sufficiently recessed. Fig 4 provides guidelines for dimensioning. The groove should be designed according to the standard values for static application of O-rings.

The hardness of the O-ring should be approximately 70° IRH.

#### Examples of typical bearing arrangements

Typical bearing arrangements used in industrial electric motors and generators are shown on pages 41 to 46.

Fig 4

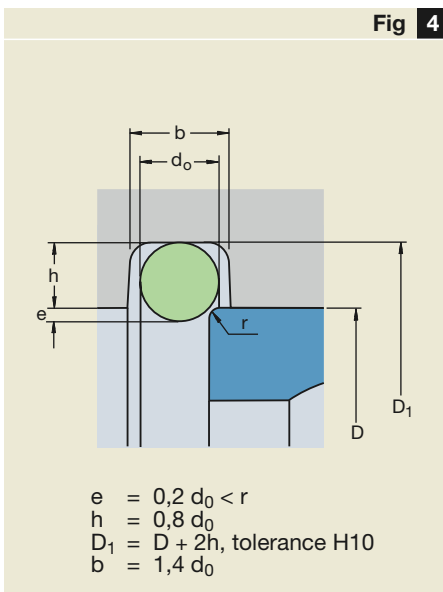

Design of the O-ring groove

## 2 Bearing arrangements

### Selecting a bearing arrangement

Fig 5

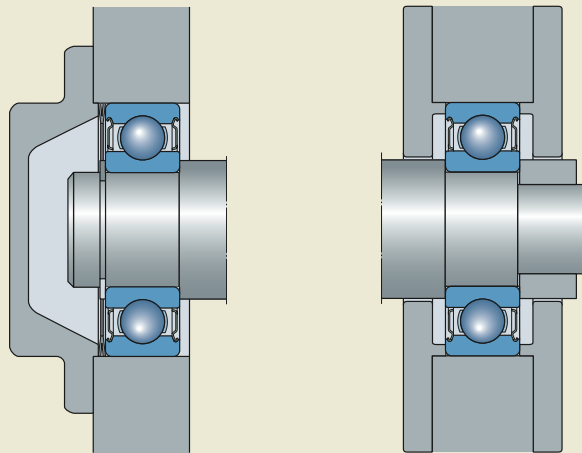

Sealed deep groove ball bearing + sealed deep groove ball bearing

2

Fig 6

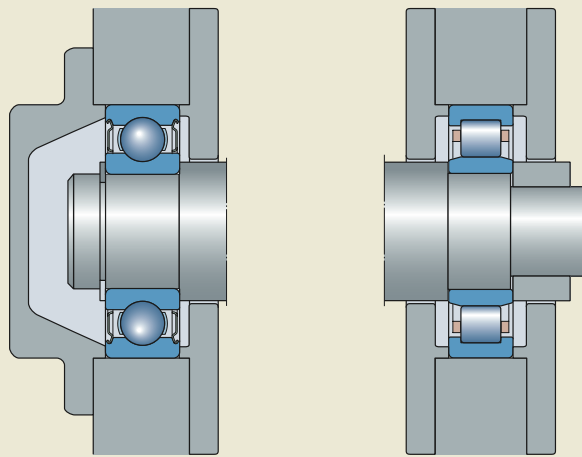

Sealed deep groove ball bearing + cylindrical roller bearing

Table 1a

Type of bearing arrangement	Requirements			Guidance		Loads		Remarks
	Noise	Speed	Maintenance	Radial	Axial	Radial	Axial	
<b>Horizontal arrangements</b>								
Sealed deep groove ball bearing + sealed deep groove ball bearing (→ fig 5)	5	5	5	5	3	3	3	For small and medium size electric motors. Low maintenance. Axial guidance is not a key parameter. The non-locating bearing is spring preloaded.
Sealed deep groove ball bearing + cylindrical roller bearing (→ fig 6)	3	4	3	3	3	5	3	For medium and large size electric motors, with heavy loads on the drive side. Accommodates axial expansion within the bearing.
5 = Excellent	4 = Very good	3 = Good	2 = Fair	1 = Not recommended				

## 2 Bearing arrangements

### Selecting a bearing arrangement

Fig 7

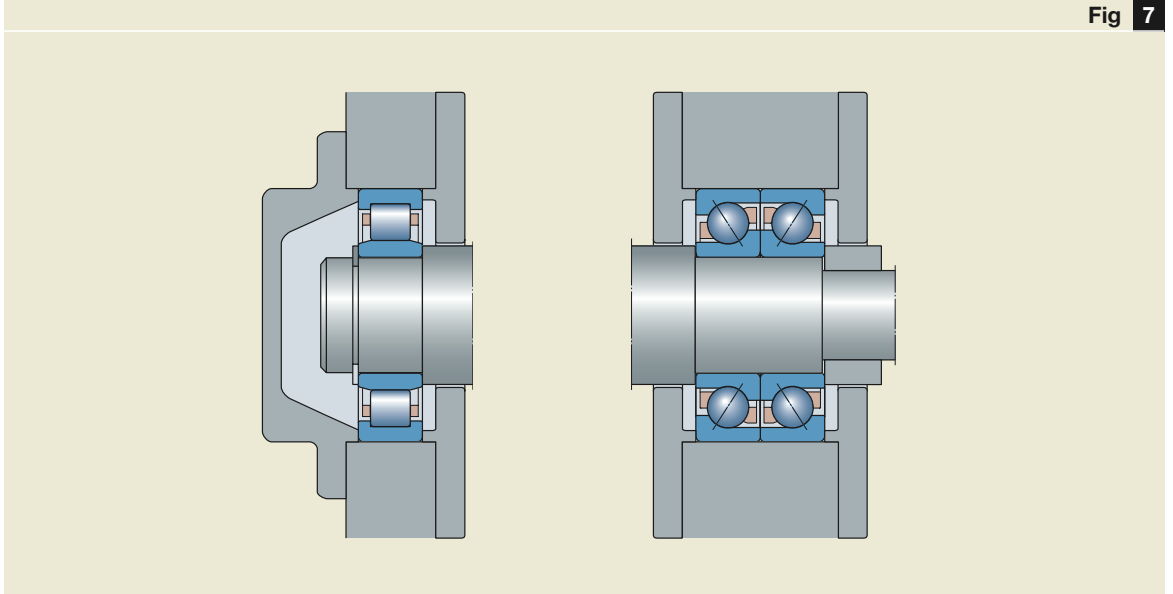

*Cylindrical roller bearing + two universally matched angular contact ball bearings mounted face-to-face*

Fig 8

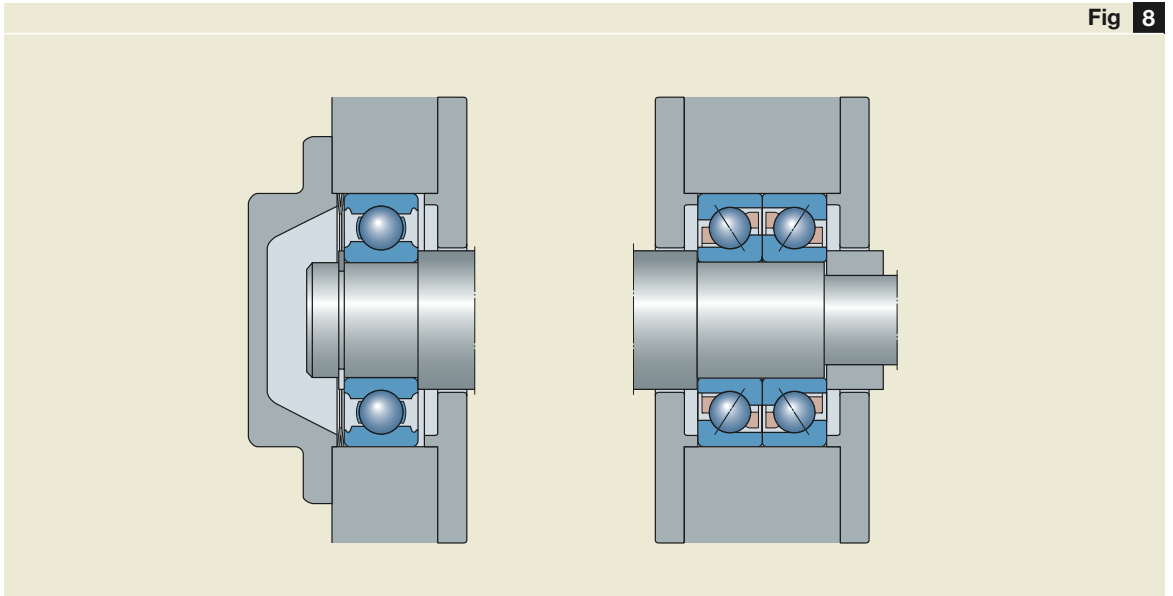

*Deep groove ball bearing + two universally matched angular contact ball bearings mounted face-to-face*

Table 1b

Type of bearing arrangement	Requirements			Guidance		Loads		Remarks
	Noise	Speed	Maintenance	Radial	Axial	Radial	Axial	
<b>Horizontal arrangements</b>								
Cylindrical roller bearing + two universally matched angular contact ball bearings (→ fig 7)	3	4	3	5	5	5	5	Electric motors with axial loads acting in both directions and heavy radial loads, or when axial guidance is important.
Deep groove ball bearing + two universally matched angular contact ball bearings (→ fig 8)	5	4	4	5	5	5	5	Small electric motors with axial loads acting in both directions and moderate radial loads or when axial guidance is important. The deep groove ball bearing is spring preloaded.
5 = Excellent	4 = Very good	3 = Good	2 = Fair	1 = Not recommended				

## 2 Bearing arrangements

### Selecting a bearing arrangement

Fig 9

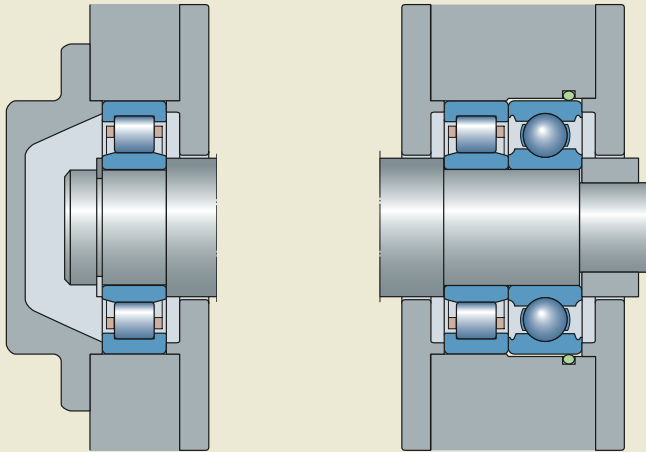

*Cylindrical roller bearing + cylindrical roller bearing and deep groove ball bearing*

2

Fig 10

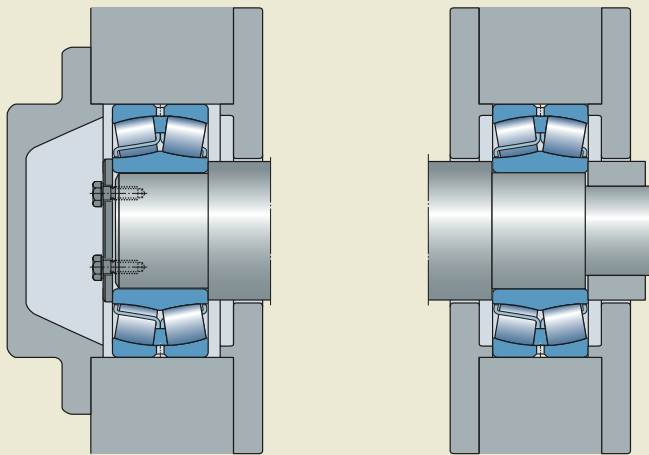

*Spherical roller bearing + spherical roller bearing*

Table 1c

Type of bearing arrangement	Requirements			Guidance		Loads		Remarks
	Noise	Speed	Maintenance	Radial	Axial	Radial	Axial	
<b>Horizontal arrangements</b>								
Cylindrical roller bearing + cylindrical roller bearing and deep groove ball bearing (→ fig 9)	3	4	3	3	3	5	3	For large electric machines. The deep groove ball bearing, which is radially free, uses an O-ring to prevent outer ring rotation.
Spherical roller bearing + spherical roller bearing (→ fig 10)	3	3	3	3	3	5	4	For very large electric machines and very heavy loads.
5 = Excellent	4 = Very good	3 = Good	2 = Fair	1 = Not recommended				

## 2 Bearing arrangements

### Selecting a bearing arrangement

Fig 11

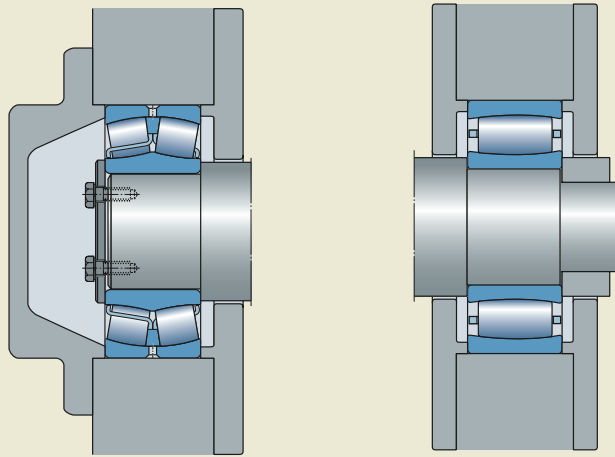

Spherical roller bearing + CARB toroidal roller bearing

Fig 12

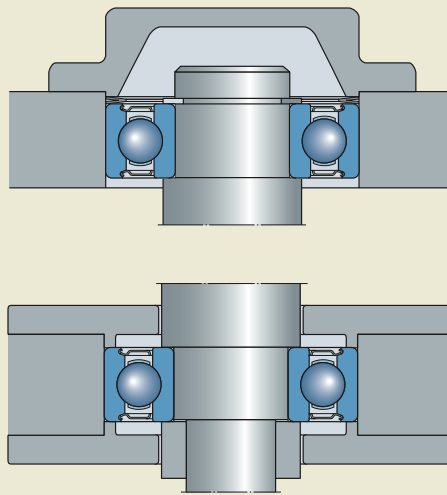

Sealed deep groove ball bearing + sealed deep groove ball bearing

Table 1d

Type of bearing arrangement	Requirements			Guidance		Loads		Remarks
	Noise	Speed	Maintenance	Radial	Axial	Radial	Axial	
<b>Horizontal arrangements</b>								
Spherical roller bearing + CARB toroidal roller bearing (→ fig 11)	3	3	3	3	3	5	4	For very large electric machines and very heavy loads. CARB toroidal roller bearing used in the non-locating position to accommodate axial expansion within the bearing.
<b>Vertical arrangements</b>								
Sealed deep groove ball bearing + sealed deep groove ball bearing (→ fig 12)	5	5	5	5	3	3	2	Standard arrangement for small and medium electric motors. Small axial loads in both directions. Upper bearing spring preloaded.
5 = Excellent	4 = Very good	3 = Good	2 = Fair	1 = Not recommended				



## 2 Bearing arrangements

### Selecting a bearing arrangement

Fig 13

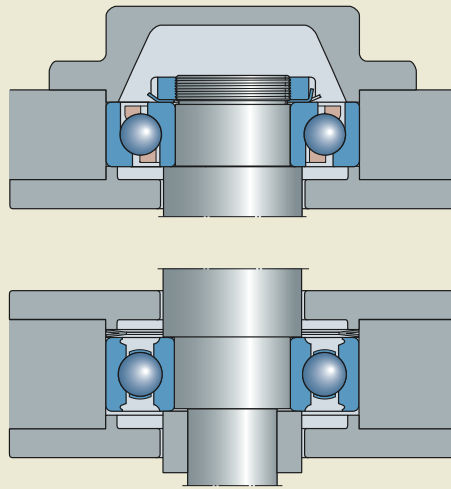

Angular contact ball bearing + deep groove ball bearing

Fig 14

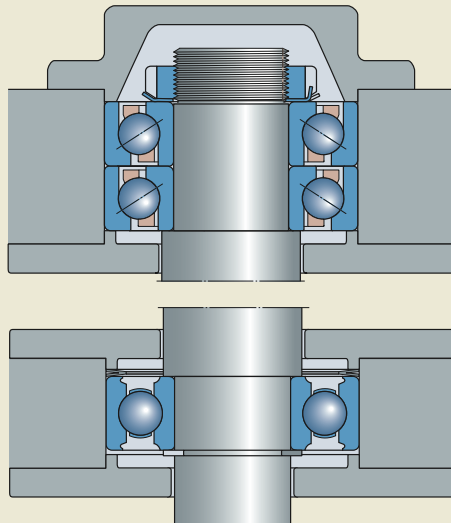

Two universally matchable angular contact ball bearings in tandem arrangement + deep groove ball bearing

Table 1e

Type of bearing arrangement	Requirements			Guidance		Loads		Remarks
	Noise	Speed	Mainten- ance	Radial	Axial	Radial	Axial	
<b>Vertical arrangements</b>								
Angular contact ball bearing + deep groove ball bearing (→ fig 13)	5	4	5	5	5	3	4	Standard arrangement for larger electric motors with moderate axial loads. Axial loads in one direction (downwards). Lower bearing is spring preloaded.
Two universally matchable angular contact ball bearings in tandem arrangement + deep groove ball bearing (→ fig 14)	5	3	4	5	5	3	5	Standard arrangement for larger electric motors with heavy axial loads. Axial loads in one direction (downwards). Lower bearing is spring preloaded.
5 = Excellent	4 = Very good	3 = Good	2 = Fair	1 = Not recommended				

## 2 Bearing arrangements

### Selecting a bearing arrangement

Fig 15

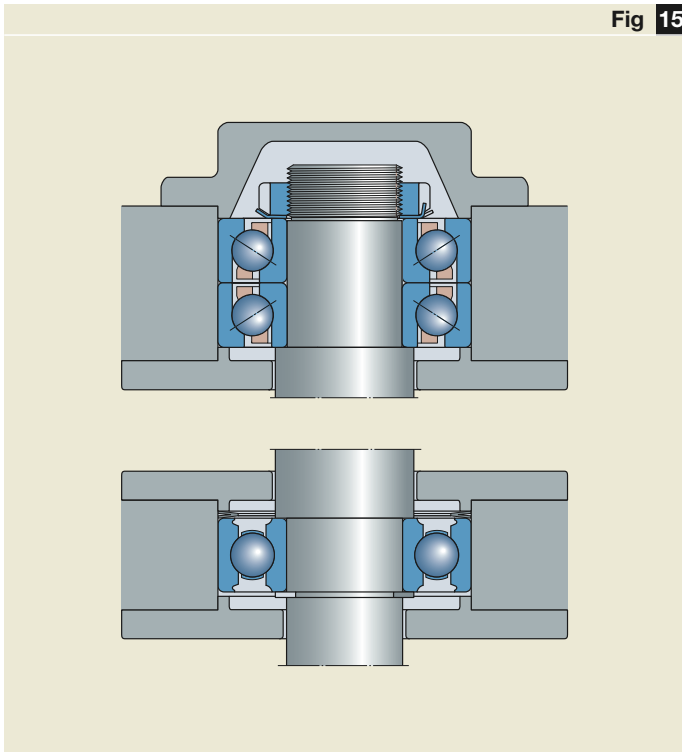

*Two universally matchable angular contact ball bearings in face-to-face arrangement + deep groove ball bearing*

Fig 16

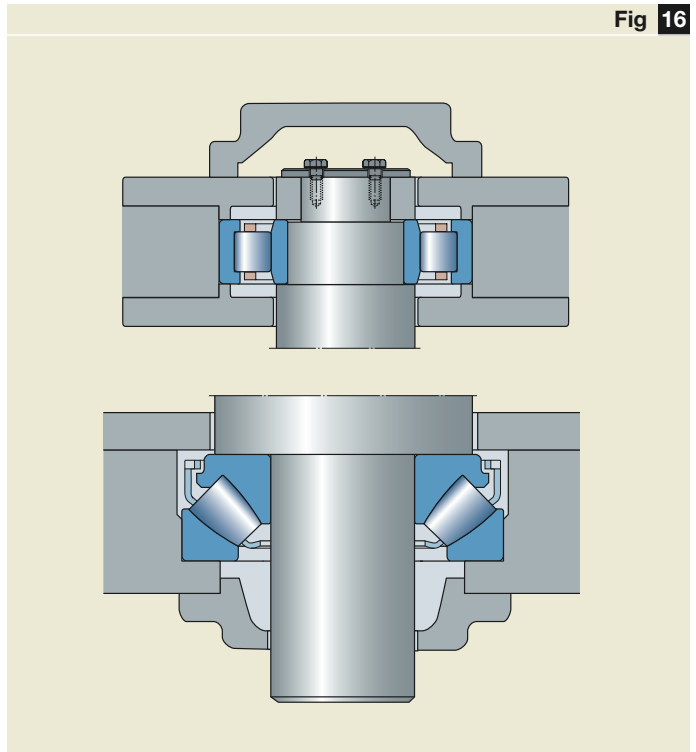

*Cylindrical roller bearing + spherical roller thrust bearing*

Table 1f

Type of bearing arrangement	Requirements			Guidance		Loads		Remarks
	Noise	Speed	Maintenance	Radial	Axial	Radial	Axial	
<b>Vertical arrangements</b>								
Two universally matchable angular contact ball bearings face-to-face arrangement + deep groove ball bearing (→ fig 15)	5	3	4	5	5	4	4	Standard arrangement for larger electric motors with axial loads in both directions. Moderate axial loads. Lower bearing is spring preloaded.
Spherical roller thrust bearing + cylindrical roller bearing (→ fig 16)	3	3	4	3	3	5	5	For large vertical electric machines. Heavy downward axial load
5 = Excellent    4 = Very good    3 = Good    2 = Fair    1 = Not recommended								

## Preloading with springs

The simplest way to preload a bearing is to use a spring washer or a set of helicoidal springs to apply pressure to the outer ring of the non-locating bearing (→ fig 17). To do this the outer ring must have a loose fit and be able to move axially on its seating. With springs the preload force remains fairly constant even when there is an axial displacement due to thermal expansion of the shaft.

For small electric machines (light rotor mass) the requisite preload force can be estimated from:

$$F_a = k d$$

where

$F_a$  = preload force, N

$k$  = factor (→ recommendations under “Quiet running” and “Preventing false brinelling”)

$d$  = bearing bore diameter, mm

### Quiet running

To reduce operating noise in an electric motor fitted with deep groove ball bearings, an axial preload should be applied to the outer ring of the non-locating bearing. This preload will result in an axial load distributed evenly to all the balls in both bearings to substantially reduce noise and vibration levels. To calculate the required preload, generally factor  $k$  values between 5 and 10 are considered appropriate. To adjust the value of the factor  $k$

more precisely, tests have to be performed to check the influence of component tolerances and noise levels.

### Preventing false brinelling

Damage from false brinelling can occur if bearings are subjected to vibrations when stationary or during transportation of the electrical machine. This type of damage is described in **chapter 6** “Failure modes and corrective actions”, starting on **page 91**.

Axial preloading with springs can substantially reduce damage from false brinelling. If the bearings are spring loaded to reduce false brinelling and not to reduce noise, a factor  $k$  value of 20 should be used to calculate the requisite preload.

### Preventing smearing

In order to provide satisfactory operation, ball and roller bearings must always be subjected to a minimum load, particularly if they are to operate at high speeds or are subjected to high accelerations or rapid changes in direction of load. Under such conditions, the inertia forces in the rolling elements and cage, and the friction in the lubricant, can have a detrimental influence on the rolling conditions in the bearing arrangement and may cause damaging sliding movements to occur between the rolling elements and raceways. The formula to calculate the requisite minimum load to be applied can be found in the relevant product sections in the SKF General Catalogue or in the

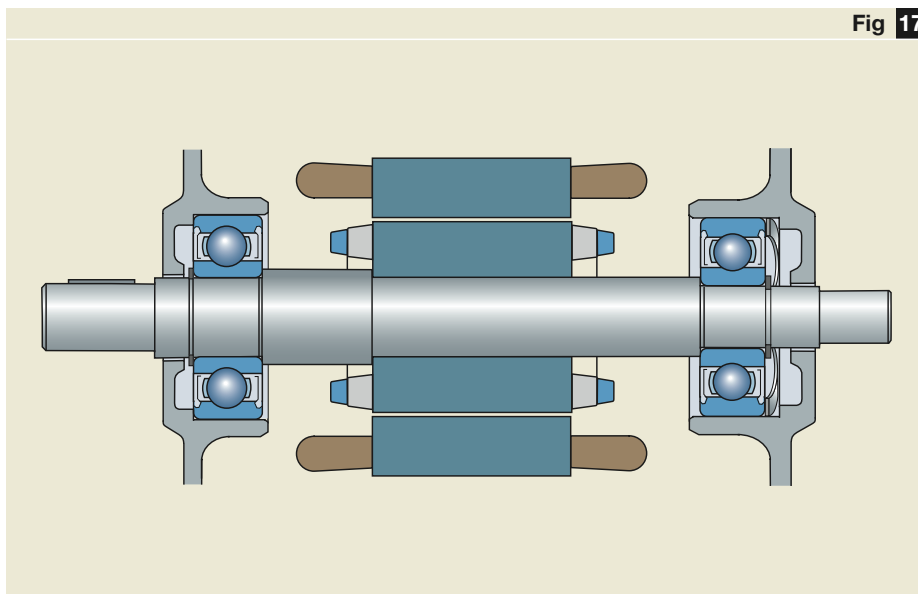

Fig 17

*Bearing arrangement with spring preloaded deep groove ball bearings*

## 2 Bearing arrangements

### Preloading with springs

SKF Interactive Engineering Catalogue, available on CD-ROM or online at [www.skf.com](http://www.skf.com).

When starting up at low temperatures or when the lubricant is highly viscous, even greater minimum loads may be required. The weight of the components supported by the bearing, together with external forces, generally exceeds the requisite minimum load. If this is not the case, the bearing must be subjected to an additional load.

For applications where deep groove ball bearings are used, an axial preload can be applied by using springs. Particular attention needs to be paid to electric machines having a rigid coupling, generally resulting in a hyperstatic bearing system. When rigid couplings are aligned very accurately, by using laser-aligning equipment for instance, the drive end bearing might become relatively unloaded, the load being taken by the bearings on the non-drive end and the coupling shaft. In this case an arrangement with spring preloaded deep groove ball bearings is recommended.

## 2 Bearing arrangements

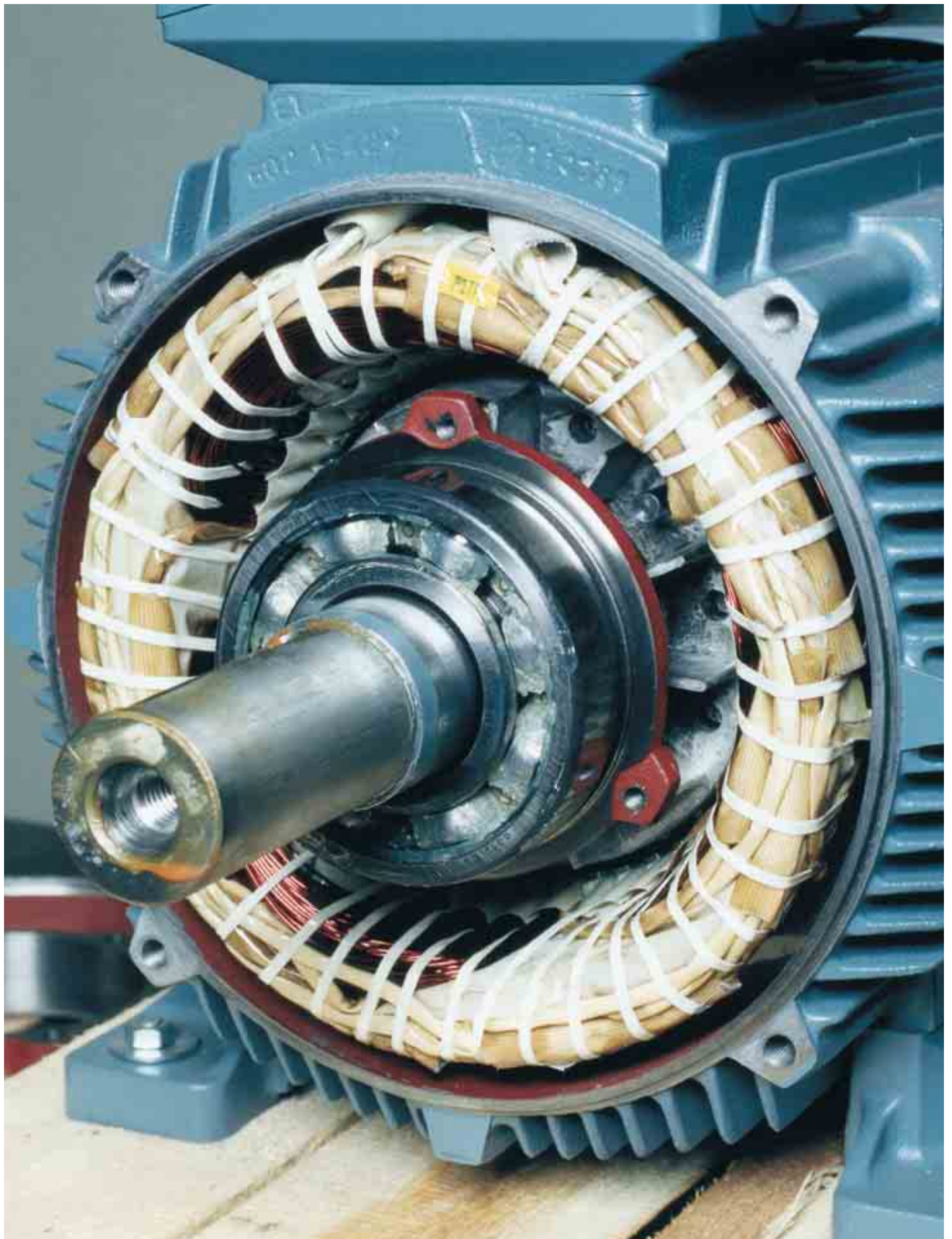

### 3 Tolerances and fits

Shaft and housing  
tolerances ..... 52

Recommended fits ..... 54



# Tolerances and fits

A rolling bearing is a precision product. If the load carrying ability of the bearing is to be fully realized, the outer ring must be supported around its complete circumference and across the entire width of the raceway. This critical support or bearing seating must be stiff and even and must be accurate enough to meet the objectives of the application. The same holds true for the shaft. It must be straight, smooth, balanced and sized correctly to meet key operational objectives.

### 3 Tolerances and fits Shaft and housing tolerances

## Shaft and housing tolerances

To prevent relative movement of the inner ring to the shaft and of the outer ring to the housing, proper shaft and housing fits must be applied. At the same time the bearing internal clearance in operation must be kept within acceptable limits.

A limited number of ISO tolerance grades are used for rolling bearing applications.

**Fig 1** illustrates the position of the most commonly used tolerance grades relative to the bearing bore and outside diameter tolerances. The light-blue areas on the bearing show the tolerance of the bore diameter and outside diameter respectively. The red bars show the tolerance range for shafts (lower half) and housings (upper half).

#### Loading conditions

A “rotating load” pertains if the bearing ring rotates and the load is stationary, or vice versa. The ring subjected to a rotating load should have an interference fit, the value depends on the

operating conditions and the bearing type and size.

A “stationary load” pertains when both the bearing ring and the load are stationary, or if the ring and load rotate at the same speed so that the load is always directed towards the same point on the ring.

Normally, under these conditions the ring should have a clearance fit. However, when load directions vary, especially where heavy loads are involved, both rings should have an interference fit. The same inner ring fit as for a rotating load is recommended. The outer ring may have a slightly looser fit. Bearings that can accommodate axial displacement internally – like CARB toroidal bearings and some cylindrical roller bearings – usually have an interference fit on both rings.

The load conditions are described in **fig 2**.

#### Tolerances

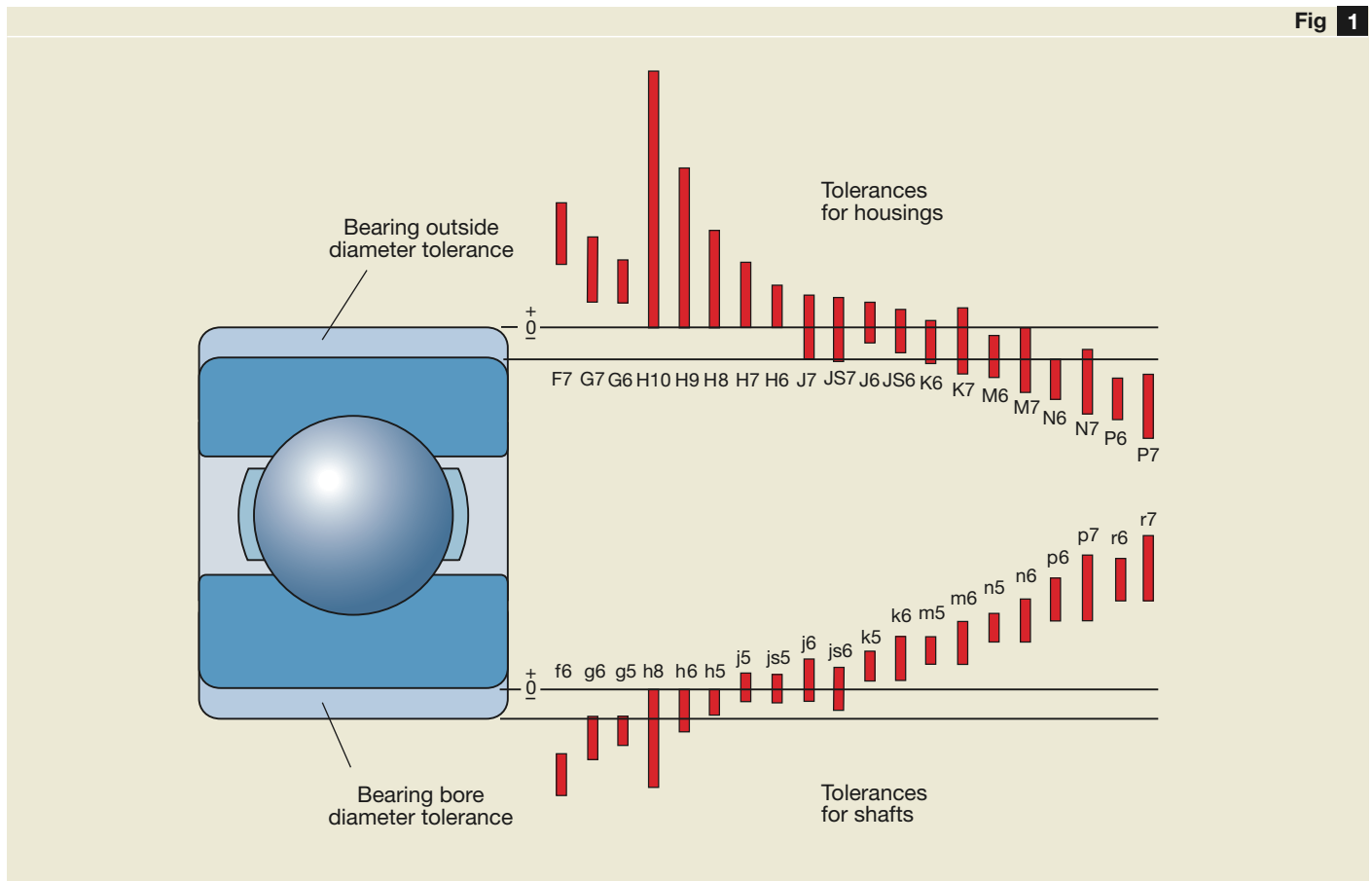



### 3 Tolerances and fits

#### Shaft and housing tolerances

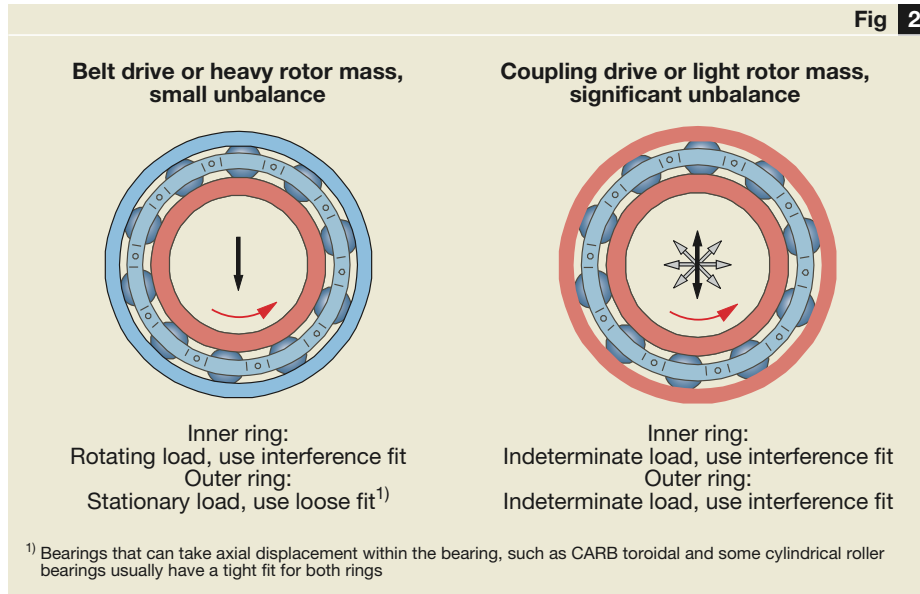

*Loading conditions in electric motors*

#### Influence of load magnitude

To prevent “creeping”, (very slow rotational movement of a ring on or in its seating), the fit should be selected relative to the load and bearing size. The heavier the load or the larger the bearing, the tighter the interference fit should be.

This can significantly increase operating temperatures, accelerate lubricant deterioration and cause the bearing to fail prematurely. In severe cases the ring may fracture.

#### Importance of appropriate fits

Proper fits for the bearing on the shaft and in the housing are keys to long bearing service life. If the fits are too loose, fretting, smearing and wear can occur (→ fig 3). If heavy loads prevail, there is even the risk of ring fracture.

If the fits are too tight, the reduction in bearing internal clearance may result in too little operating internal clearance.

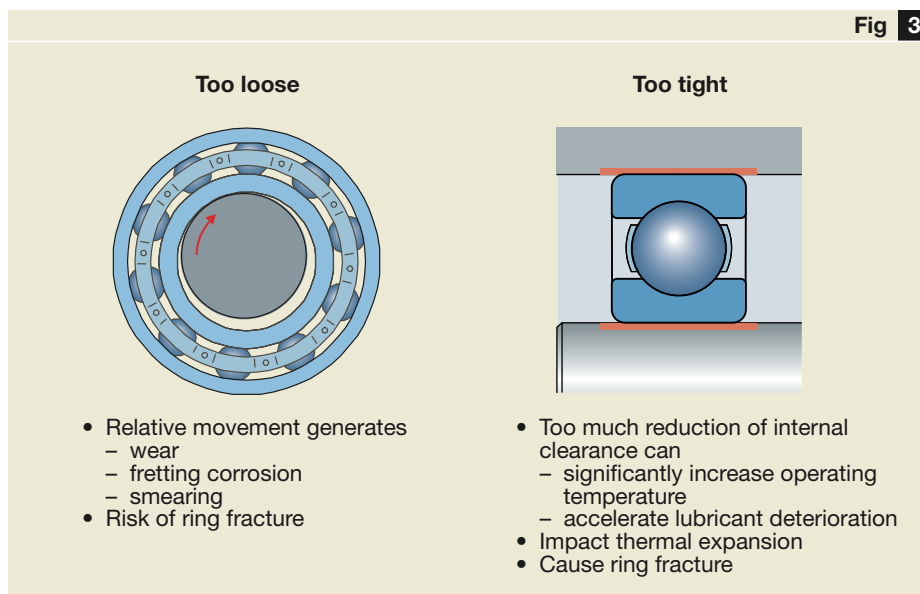

*Consequences arising from wrong fits*

### 3 Tolerances and fits Recommended fits

## Recommended fits

For electric motors, recommendations for bearing fits for solid shafts will be found in:

**Table 1:** radial bearings with cylindrical bore

**Table 2:** thrust bearings

and for cast iron and steel housings in:

**Table 3:** radial bearings – non split housings

Additional information on recommended fits can be found in the SKF General Catalogue in the section “Application of bearings”, or in the SKF Interactive

Engineering Catalogue on CD-ROM or online at [www.skf.com](http://www.skf.com)

If tight fits need to be applied and there is a risk that the internal clearance within the bearing will be significantly reduced, select a bearing with a larger internal clearance than you might normally use (→ section “Bearing selection” on **page 17**).

When a bearing in an electric motor needs to be replaced, the shaft and housing seatings need to be checked. Information on the applied fits should be found in the maintenance manual of the motor manufacturer. If this information is not available see **tables 1** to **3**.

**Table 1**

Radial bearings with cylindrical bore				
Conditions	Shaft diameter, mm			Tolerance
	Ball bearings <sup>1)</sup>	Cylindrical roller bearings	Spherical and toroidal roller bearings	
<b>Rotating inner ring load or direction of load indeterminate</b>				
Light and variable loads ( $P \leq 0,06 C$ )	(18) to 100 (100) to 140	$\leq 40$ (40) to 100	– –	j5 (j6) k5 (k6)
Normal and heavy loads ( $P > 0,06 C$ )	$\leq 18$	–	–	j5
	(18) to 100 (100) to 140 (140) to 200 (200) to 280	$\leq 40$ (40) to 100 (100) to 140 (140) to 200 (200) to 400	$\leq 40$ (40) to 65 (65) to 100 (100) to 140 (140) to 280 (280) to 500 > 500	k5 m5 m6 n6 p6 r6 <sup>2)</sup> r7 <sup>2)</sup>
Very heavy loads and shock loads with difficult working conditions ( $P > 0,12 C$ )	–	(50) to 140	(50) to 100	n6 <sup>2)</sup>
	–	(140) to 200	(100) to 140	p6 <sup>2)</sup>
	–	> 200	> 140	r6 <sup>2)</sup>

<sup>1)</sup> For deep groove ball bearings C3 radial clearance is generally recommended  
<sup>2)</sup> Bearings with radial internal clearance greater than Normal may be necessary

*Fits for radial bearings on solid steel shafts*

**Table 2**

Thrust bearings		
Conditions	Shaft diameter, mm	Tolerance
<b>Combined radial and axial loads acting on spherical roller thrust bearings</b>		
Stationary load on shaft washer	$\leq 250$ > 250	j6 js6
Rotating load on shaft washer, or direction of load indeterminate	$\leq 200$ (200) to 400 > 400	k6 m6 n6

*Fits for thrust bearings on solid steel shafts*

### 3 Tolerances and fits Recommended fits

#### Fits for aluminium housings

The coefficient of expansion for aluminium is more than two times greater than for cast iron or steel. Therefore, for motors with aluminium housings, steps should be taken to prevent the outer ring from rotating in its seating. To do this, start by selecting a tighter tolerance for the housing, e.g. use a J7 instead of an H7. Another way to prevent the outer ring from moving, is to cut an O-ring groove into the bearing seating and install a rubber O-ring. When designed correctly, the O-ring will apply enough pressure so that the bearing outer ring will be held in place and unable to spin in the housing bore (→ fig 4).

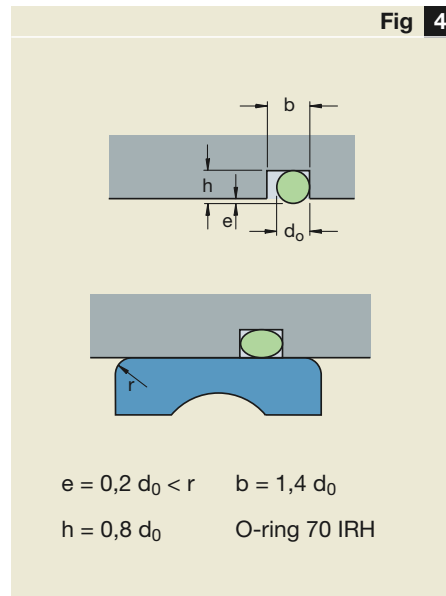

Dimensions of O-ring groove

#### Influence of temperature gradient when selecting the housing fit

Electric motors and generators generate heat in the rotor and stator coils and are often equipped with a fan to cool the system. These fans, which are used to cool the housing (motor-end shield), can create a temperature differential between the housing and the bearing outer ring. This can cause

a problem with the non-locating bearing if it needs to move axially on its seating to accommodate thermal expansion of the shaft. To correct the problem, switch to a looser housing fit, i.e. from H7 to G6 or place the axially free bearing in a position where there is hot air flow against the end shield.

3

Table 3

Radial bearings – non-split housings			
Conditions	Examples	Tolerance	Displacement of outer ring
<b>Stationary outer ring load</b>			
Loads of all kinds	Catalogue electric motors	<b>H6 (H7<sup>1)</sup>)</b>	Can be displaced
Heat conduction through shaft, efficient stator cooling	Large electric machines with spherical roller bearings. Induction motors	<b>G6 (G7<sup>2)</sup>)</b>	Can be displaced
Accurate and quiet running	Small electric motors	<b>J6<sup>3)</sup></b>	Can be displaced as a rule
<b>Direction of load indeterminate</b>			
Light and normal loads ( $P \leq 0,12 C$ ) axial displacement of outer ring desirable	Medium sized electric machines	<b>J7<sup>4)</sup></b>	Can be displaced as a rule
Normal and heavy loads ( $P > 0,06 C$ ), axial displacement of outer ring unnecessary	Medium-sized or large electric machines with cylindrical or toroidal roller bearings	<b>K7</b>	Cannot be displaced
Heavy shock loads	Heavy traction motors	<b>M7</b>	Cannot be displaced

<sup>1)</sup> For large bearings ( $D > 250$  mm) and temperature differences between outer ring and housing  $> 10$  °C, G7 should be used instead of H7  
<sup>2)</sup> For large bearings ( $D > 250$  mm) and temperature differences between outer ring and housing  $> 10$  °C, F7 should be used instead of G7  
<sup>3)</sup> When easy displacement is required use H6 instead of J6  
<sup>4)</sup> When easy displacement is required use H7 instead of J7

**Fits for radial bearings in cast iron and steel housings**

### 3 Tolerances and fits Recommended fits

#### Rotating loads or vibrations and loose outer ring fit

In some applications the direction of load is indeterminate, such as:

- Small motors with light rotor mass, together with an unbalance
- Motors with high and strong vibration levels, such as generators attached to thermal engines.

Under these conditions, if a non-separable bearing, like a deep groove ball bearing, is used in the non-locating position, there is a risk that the outer ring will “creep” in its seating, and cause excessive wear. One such example is marine applications where motors are submitted to relatively high vibrations.

There are two simple ways to hold the outer ring in place, and virtually eliminate the wear caused by the ring “creeping” on its seating.

For smaller motors, the simplest solution is to preload the bearing with springs. Another method is to install an O-ring in a groove in the housing. Depending on the application, either of these methods can be used to hold the outer ring in place.

If neither of these methods is sufficient, the housing seating can undergo heat treatment or surface treatment or a hardened insert can be used. Increasing the surface hardness above 30 to 35 HRC has been proven to be effective.

Fig 5

#### Accuracy of form and position for bearing seatings on shafts and in housings

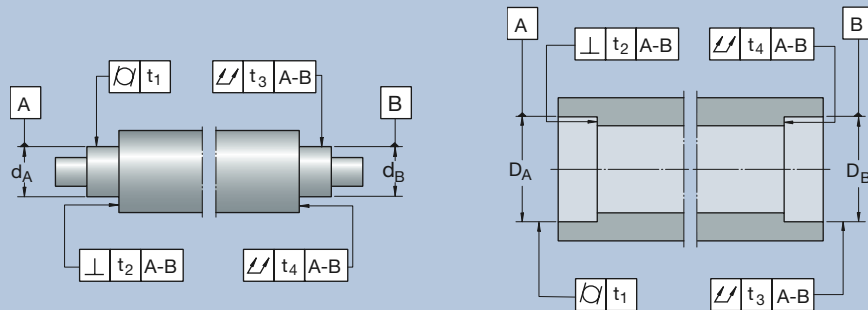

**Surface**  
Characteristic

Symbol for characteristic tolerance

**Permissible deviations**  
Bearings of tolerance class<sup>1)</sup>



#### Cylindrical seating

Cylindricity	$\text{Ⓞ}$	$t_1$	IT5/2	IT4/2	IT3/2	IT2/2
Total radial runout	$\text{Ⓢ}$	$t_3$	IT5/2	IT4/2	IT3/2	IT2/2

#### Flat abutment

Rectangularity	$\text{⊥}$	$t_2$	IT5	IT4	IT3	IT2
Total axial runout	$\text{Ⓣ}$	$t_4$	IT5	IT4	IT3	IT2

#### Explanation

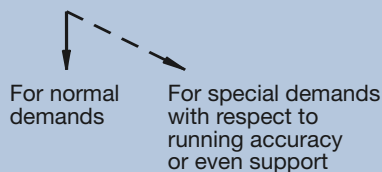

<sup>1)</sup> For bearings of higher accuracy (tolerance class P4 etc.) please refer to SKF catalogue “High precision bearings”

### 3 Tolerances and fits

#### Recommended fits

#### SKF antifret LGAF 3E

SKF offers a high performing anti-fretting agent, SKF LGAF 3E. This is a greasy, smooth paste specially developed to prevent fretting corrosion between metal surfaces in loose fit arrangements.

#### Accuracy of form and position

A cylindrical bearing seating and abutment shoulder, whether they are on the shaft or in the housing, should correspond in accuracy to the selected bearing (→ fig 5 and table 2). Tolerances that should be considered include:

- Tolerances for cylindrical form ( $t_1$ )
- Tolerances for perpendicularity ( $t_2$ )
- Tolerances for total radial and axial runout ( $t_3$ )

For additional information regarding tolerances and fits, as well as accuracy of form and position for bearing seatings on shafts and in housings, please consult the SKF General Catalogue, section “Application of bearings”, the SKF Interactive Engineering Catalogue on CD-ROM or online at [www.skf.com](http://www.skf.com), or the SKF Bearing Maintenance Handbook.

#### Dimension limits for ISO tolerance grades

Table 2

Nominal dimension		Tolerance grade												
over	incl.	IT0	IT1	IT2	IT3	IT4	IT5	IT6	IT7	IT8	IT9	IT10	IT11	IT12
mm		µm												
1	3	0,5	0,8	1,2	2	3	4	6	10	14	25	40	60	100
3	6	0,6	1	1,5	2,5	4	5	8	12	18	30	48	75	120
6	10	0,6	1	1,5	2,5	4	6	9	15	22	36	58	90	150
10	18	0,8	1,2	2	3	5	8	11	18	27	43	70	110	180
18	30	1	1,5	2,5	4	6	9	13	21	33	52	84	130	210
30	50	1	1,5	2,5	4	7	11	16	25	39	62	100	160	250
50	80	1,2	2	3	5	8	13	19	30	46	74	120	190	300
80	120	1,5	2,5	4	6	10	15	22	35	54	87	140	220	350
120	180	2	3,5	5	8	12	18	25	40	63	100	160	250	400
180	250	3	4,5	7	10	14	20	29	46	72	115	185	290	460
250	315	4	6	8	12	16	23	32	52	81	130	210	320	520
315	400	5	7	9	13	18	25	36	57	89	140	230	360	570
400	500	6	8	10	15	20	27	40	63	97	155	250	400	630
500	630	–	–	–	–	–	28	44	70	110	175	280	440	700
630	800	–	–	–	–	–	35	50	80	125	200	320	500	800
800	1 000	–	–	–	–	–	36	56	90	140	230	360	560	900
1 000	1 250	–	–	–	–	–	42	66	105	165	260	420	660	1 050
1 250	1 600	–	–	–	–	–	50	78	125	195	310	500	780	1 250
1 600	2 000	–	–	–	–	–	60	92	150	230	370	600	920	1 500
2 000	2 500	–	–	–	–	–	70	110	175	280	440	700	1 100	1 750

## 4 Lubrication and sealing

Lubrication ..... 59

Grease selection ..... 62

Relubrication intervals ... 64

Grease life in sealed  
bearings ..... 70

Oil lubrication ..... 72

Seals ..... 74



# Lubrication and sealing

If rolling bearings are to operate reliably and realize their full service life they must be adequately lubricated. The function of the lubricant is to form a protective oil film that separates the bearing components and prevent metal-to-metal contact. The lubricant also protects the bearing and related components against corrosion. When grease is used as a lubricant, it can also help protect the bearing against contaminants like dirt, dust and water.

## Lubrication

Some important properties of a lubricant include viscosity, film forming ability and consistency (for grease). The most important determinants of the film thickness are:

- rotational speed
- bearing temperature
- load
- base oil viscosity

## Grease lubrication

Under normal speed and temperature conditions, the bearings in electric motors are usually lubricated with grease. Grease has a number of advantages when compared to oil. It enables simpler, more cost effective housing and sealing designs; while offering better adhesion and protection against contaminants.

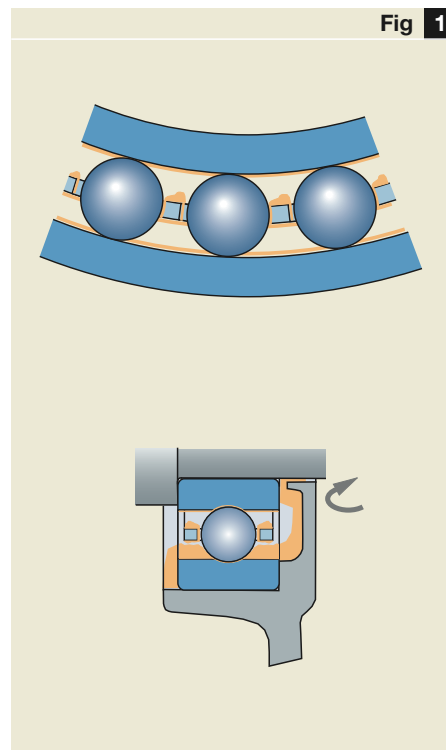

*Lubrication mechanisms in a rolling bearing*

## 4 Lubrication and sealing

### Lubrication

#### What is grease?

Lubricating greases consist of a mineral or synthetic oil combined with a thickener, usually metallic soaps. However, other thickeners like polyurea can be used for superior high temperature performance. The base oil constitutes 85–90 % of the grease and the thickener around 10 %. Additives will also be included to enhance certain properties of the grease.

#### Base oil viscosity

The effectiveness of the lubricant is primarily determined by the degree of surface separation between the rolling contact surfaces. If an adequate lubricant film is to be formed, the lubricant must have a given minimum viscosity when the application has reached its normal operating temperature. The lubricant condition is described by the viscosity ratio  $\kappa$ . The ratio is the actual viscosity  $\nu$  to the rated viscosity  $\nu_1$  for adequate lubrication, both values being considered when the lubricant is at normal operating temperature:

$$\kappa = \frac{\nu}{\nu_1}$$

where

$\kappa$  = viscosity ratio

$\nu$  = actual operating viscosity of the lubricant at operating temperature,  $\text{mm}^2/\text{s}$

$\nu_1$  = rated viscosity depending on the bearing mean diameter and rotational speed at operating temperature,  $\text{mm}^2/\text{s}$

See **diagrams 5** and **6** on **page 73**.

Under normal operating conditions, the viscosity ratio should be larger than 1.

#### Consistency

Greases are divided into various consistency classes according to the National Lubricating Grease Institute (NLGI) scale. The consistency of grease used for bearing lubrication should not change drastically when operated within its specified temperature range after mechanical working. Greases that soften at elevated temperatures may leak from the bearing arrangement. Those that stiffen at low temperatures may restrict rotation of the bearing or have insufficient oil bleeding.

For bearings in electric motors and generators normally two grades are used:

Diagram 1

#### The SKF traffic light concept

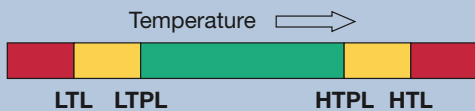
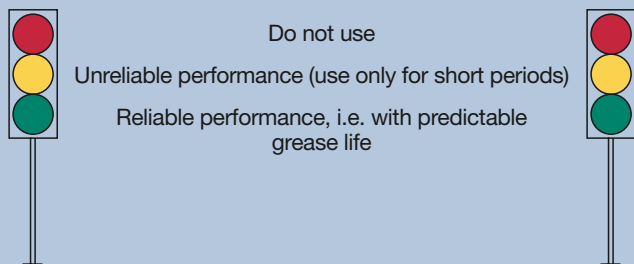

<b>LTL</b>	Low Temperature Limit
<b>LTPL</b>	Low Temperature Performance Limit
<b>HTPL</b>	High Temperature Performance Limit
<b>HTL</b>	High Temperature Limit

Diagram 2

#### The SKF traffic light concept – SKF greases in electric motors

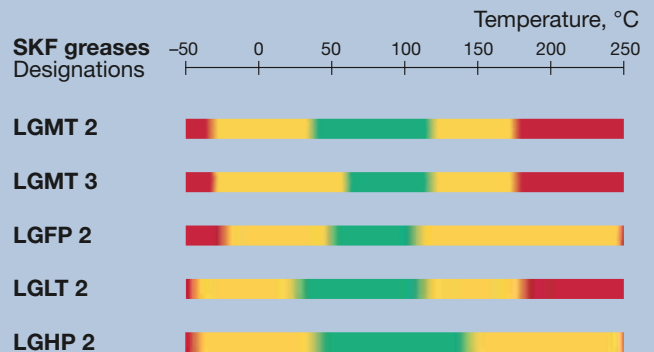

For operating temperatures above 150 °C, SKF LGET 2 is recommended



## 4 Lubrication and sealing

### Lubrication

Soft grease: low consistency,  
NLGI grade 2  
Stiff grease: high consistency,  
NLGI grade 3

#### Temperature range – the SKF traffic light concept

The temperature range over which a grease can be used depends largely on the type of base oil and thickener used as well as the additives. The relevant temperatures are schematically illustrated in **diagram 1** in the form of a “double traffic light”.

The extreme temperature limits, i.e. low temperature limit and the high temperature limit, are well defined.

- The low temperature limit (LTL), i.e. the lowest temperature at which the grease will allow the bearing to be started up without difficulty, is largely determined by the type of base oil and its viscosity.
- The high temperature limit (HTL) is determined by the type of thickener and for soap base greases it is given by the dropping point. The dropping point indicates the temperature at which the grease loses its consistency and becomes a fluid.

It is evident that operation below the low temperature limit and above the high temperature limit is not advised as shown in **diagram 1** by the red zones. Although grease suppliers indicate the specific values for the low and high temperature limits in their product information, the really important temperatures for reliable operation are given by the SKF values for

- the low temperature performance limit (LTPL) and
- the high temperature performance limit (HTPL).

It is within these two limits, the green zone in **diagram 1**, where the grease will function reliably and grease life can be determined accurately. Since the definition of the high temperature performance limit is not standardized internationally care must be taken when interpreting suppliers' data.

At temperatures above the high temperature performance limit (HTPL), grease will age and oxidize with in-

creasing rapidity and the by-products of the oxidation will have a detrimental effect on lubrication. Therefore, temperatures in the amber zone, between the high temperature performance limit and the high temperature limit (HTL) should occur only for very short periods.

An amber zone also exists for low temperatures. With decreasing temperature, the tendency of grease to bleed decreases and the stiffness (consistency) of the grease increases. This will ultimately lead to an insufficient supply of lubricant to the contact surfaces of the rolling elements and raceways. In **diagram 1**, this temperature limit is indicated by the low temperature performance limit (LTPL). Values for the low temperature performance limit are different for roller and ball bearings. Since ball bearings are easier to lubricate than roller bearings, the low temperature performance limit is less important for ball bearings. For roller bearings, however, serious damage will result when the bearings are operated continuously below this limit. Short periods in this zone e.g. during a cold start, are not harmful since the heat caused by friction will bring the bearing temperature into the green zone.

#### Additives

To obtain grease with special properties one or several additives are included. Below are some of the most commonly used:

- Anti-rust additive to improve the protection against corrosion.
- Anti-oxidants to delay the degeneration of the greases.
- EP (extreme pressure) additives to increase the load carrying capacity of the oil film.

Note that EP additives may be harmful to bearings above 80 °C. In electric motor applications, EP additives are almost never recommended due to moderate loads applied and relatively high operating temperatures.

## 4 Lubrication and sealing

### Grease selection

## Grease selection

Using the best and most suitable lubricant related to specific operating conditions is of crucial importance in obtaining appropriate motor performance and reliability. Areas of consideration should include the following:

- bearing type and size
- operating temperature
- load
- speed range
- operating conditions e.g vibration levels, orientation of the shaft (horizontal or vertical)
- cooling
- sealing efficiency
- environment

## SKF greases

For small and medium sized bearings where the grease life is longer than the expected service life of the bearings, one single filling of grease is sufficient. The grease must then be retained in the bearings and prevented from escaping.

For sealed and greased for life bearings in electric motor applications, SKF recommends the greases listed in **table 1**.

**Table 2** lists SKF greases suitable for relubricating bearings in electric motors.

Never mix different grease types since they may not be compatible (→ **table 3**). Mixing different grease types normally results in reduced performance.

It is also important to consider the grease compatibility with rubber seals and different cage materials:

**Suitable SKF greases for relubrication of bearings in electric motors**

Table 1

SKF standard, selected and special greases for prelubricated bearings in electric motors

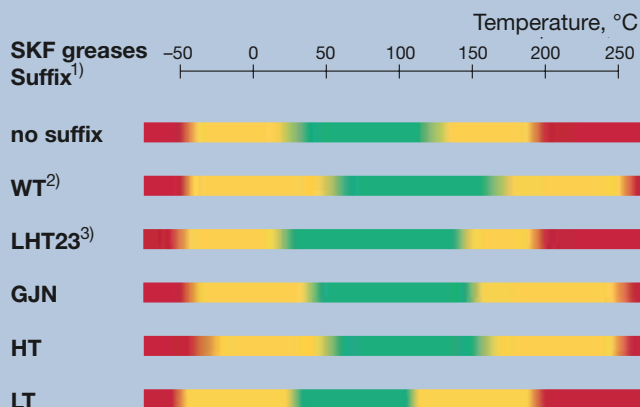

<sup>1)</sup> Grease suffix in the bearing designation, e.g. 6204-2Z/C3WT

<sup>2)</sup> High performance grease for small/medium electric motors. Wide temperature range

<sup>3)</sup> Very silent, low friction grease for small electric motors. Wide temperature range

Table 2

SKF grease Designation	Use, properties
<b>LGMT 2</b>	Small bearings (outside diameter up to approx. 62 mm) Light to moderate loads Moderate temperatures up to 80 °C/175 °F (max 120 °C/250 °F) Low friction, quiet, good protection against corrosion
<b>LGMT 3</b>	Medium-sized bearings (outside diameter > 62 mm up to approx. 240 mm) Moderate loads Moderate temperatures up to 100 °C/210 °F (max 120 °C/250 °F) Multi-purpose grease, good protection against corrosion. Vertical shafts
<b>LGLT 2</b>	Small, lightly loaded bearings at high speeds Low temperatures down to -20 °C/-4 °F Low friction, water repellant
<b>LGFP 2</b>	Low temperatures down to -20 °C/-4 °F Food compatible Water repellant
<b>LGHP 2</b>	Wide temperature range up to 150 °C/300 °F Low friction at start-up, quiet, good protection against corrosion High speeds For vertical shafts Very long life at high temperatures

## 4 Lubrication and sealing

### Grease selection

- Greases containing ester oils are in general not compatible with ACM rubber (high-temperature rubber mix).
- Standard SKF rubber mixes are compatible with standard SKF greases.
- EP additives containing sulphur act aggressively on brass cages above 100 °C.
- EP additives may act aggressively on standard polyamide cage material, PA66 (designation TN9) above 110 °C.

### How to grease a bearing

Greasing techniques vary according to the design of the bearing and its housing. However, one thing that remains constant over all bearing types is that overfilling the bearing cavity with grease will lead to increased temperatures and possible bearing failure. When greasing a bearing, be sure to leave enough space in the housing so that grease can be ejected from the bearing during start-up. In high speed motors, grease quantity should be kept at a low level. For further information consult the SKF application engineering service.

Whenever possible open bearings should be greased after they have been mounted (→ fig 2).

Non-separable bearings, like deep groove ball bearings, angular contact ball bearings spherical roller bearings

and toroidal roller (CARB) bearings, should be filled with grease from both sides if possible. In most cases, the space is so limited that it is not possible to grease the bearing from the side when it is mounted on the rotor. Therefore, it should be greased from the front with a grease gun or grease packer, e.g. SKF LAGP 400. Be sure to check that the bearing is completely filled and that the grease has penetrated the bearing and appears on the other side.

Of the bearing types used in electric motor applications only cylindrical roller bearings are separable and the most commonly used one is the NU design (two flanges on the outer ring, none on the inner ring).

The outer ring with cage and rolling elements can, and should, be greased when in the separated state during the mounting operation.

Mount the inner ring on the shaft and apply a thin layer of grease to the raceway, in order to prevent scratching of the inner ring when mounting (→ chapter 5 “Mounting and dismounting”, starting on page 77). Apply grease in the outer ring, cage and rolling elements and make sure all spaces are well filled. Mount the outer ring in the housing (motor shield). Then proceed with the assembly.

**Greasing a deep groove ball bearing mounted on a rotor shaft**

### Grease compatibility

**Table 3**

Base oils	Mineral oil	Ester oil	Polyglycol	Silicone: menthyl	Silicone: phenyl	Polyphenylether
Mineral oil	+	+	-	-	+	•
Ester oil	+	+	+	-	+	•
Polyglycol	-	+	+	-	-	-
Silicone: menthyl	-	-	-	+	+	-
Silicone: phenyl	+	+	-	+	+	+
Polyphenylether	•	•	-	-	+	+

+ = compatible  
 - = incompatible  
 • = individual testing required



**Fig 2**

## 4 Lubrication and sealing

### Relubrication intervals

Suitable quantities for replenishment of grease lubricated bearings in electric motors can be obtained from

$$G_p = 0,005 D B$$

where

$G_p$  = grease quantity to be added when replenishing, g

$D$  = bearing outside diameter, mm

$B$  = bearing width, mm

### Grease life

The life expectancy of grease depends on several factors including the type of bearing, the type of grease, the orientation and speed of the motor and the operating temperature of the bearings. For instance, roller bearings have shorter relubricating intervals than ball bearings. Other factors to consider are the sealing arrangement, operating environment and contamination.

For small ball bearings grease life usually exceeds the service life of the motor. As a result, these bearings are usually fitted with seals or shields, and lubricated for life.

However, if the grease life is shorter than the expected bearing life, the bearings need to be relubricated while the grease is still performing satisfactorily.

## Relubrication intervals

It is only possible to base recommendations on statistical rules; the SKF relubrication intervals are defined as the time period, at the end of which 99 % of the bearings are still reliably lubricated. This represents the  $L_1$  grease life.

The relubrication intervals  $t_f$  for bearings on horizontal shafts under normal and clean conditions and operating at 70 °C can be obtained from **diagram 3** as a function of

- the speed factor  $A$  multiplied by the relevant bearing factor  $b_f$  where
$$A = n d_m$$
$$n = \text{rotational speed, r/min}$$
$$d_m = \text{bearing mean diameter} = 0,5 (d + D), \text{ mm}$$
$$b_f \text{ depending on the bearing type and the applied load given in } \mathbf{table\ 4, \text{ page 66}}$$
- the load ratio  $C/P$

The relubrication interval  $t_f$  is an estimated value, valid for an operating temperature of 70 °C, using good quality lithium thickener/ mineral oil greases. When bearing operating conditions differ, adjust the relubrication intervals obtained from **diagram 3** according to the information given under “Deviating operating conditions and bearing type”.

If the speed factor  $A$  exceeds a value of 70 % of the recommended limit according to **table 4**, or if ambient temperatures are high, SKF recommends checking the operating temperature and whether a suitable lubrication method is used (→ **diagram 2**, **page 60**).

When using high performance greases, a longer relubrication interval and grease life may be possible. Contact the SKF application engineering service for additional information. See also section “Grease life in sealed bearings”, starting on **page 70**.

## 4 Lubrication and sealing

### Relubrication intervals

#### Deviating operating conditions and bearing type

##### Operating temperature

To account for the accelerated ageing of grease with increasing temperature, SKF recommends halving the intervals obtained from the **diagram 3** for every 15 °C increase in operating temperature above 70 °C, remembering that the high temperature performance limit for the grease (→ **diagram 2**, page 60, HTPL) should not be exceeded.

The relubrication interval  $t_f$  may be extended at temperatures below 70 °C if the temperature is not close to the lower temperature performance limit (→ **diagram 2**, page 60, LTPL). A total extension of the relubrication interval  $t_f$  by more than a factor of two is never recommended. In case of full complement bearings and thrust roller bearings,  $t_f$  values obtained from **diagram 3** should not be extended.

Moreover, it is not advisable to use relubrication intervals in excess of 30 000 hours.

Diagram 3

#### Relubrication intervals at operating temperatures of 70°

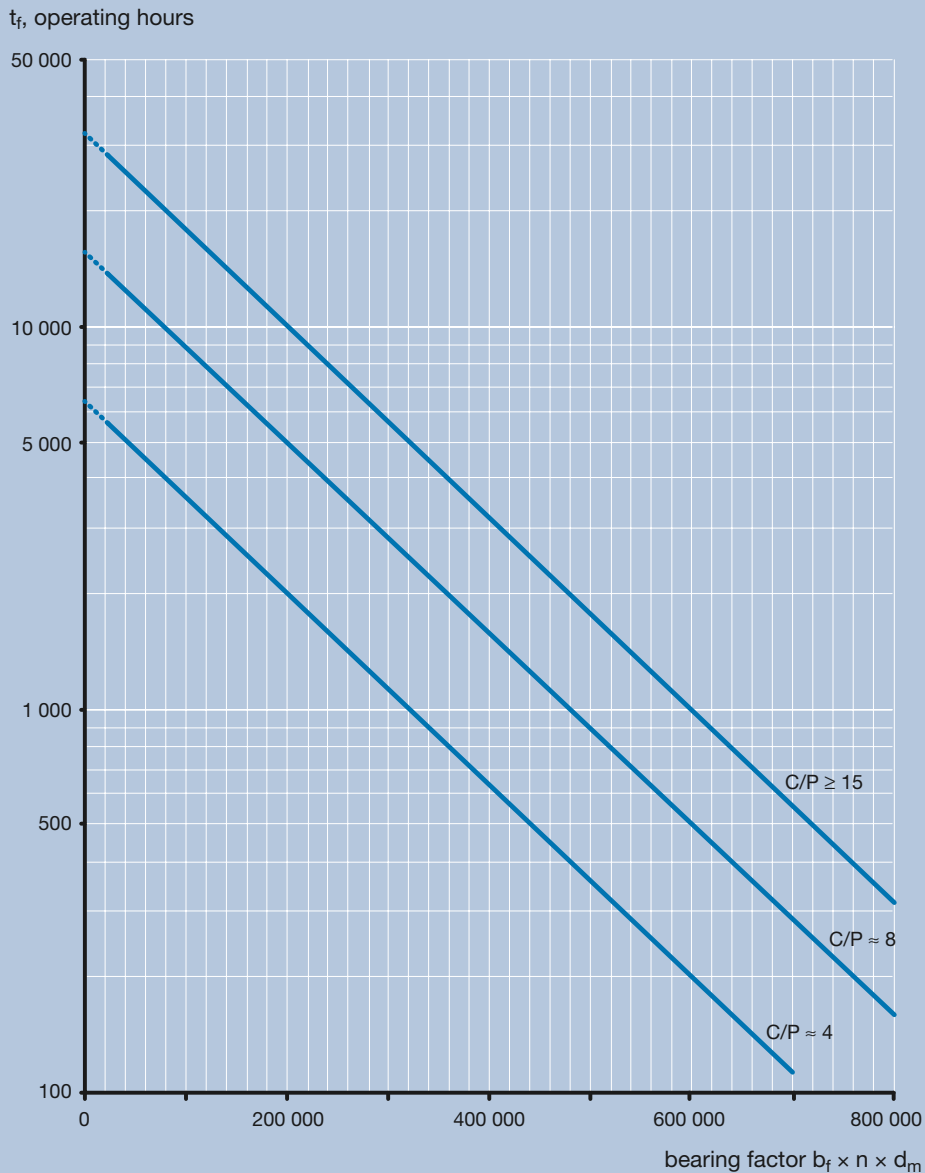

## 4 Lubrication and sealing

### Relubrication intervals

For many applications, there is a practical grease lubrication limit, when the bearing ring with the highest temperature exceeds an operating temperature of 100 °C. Above this temperature special greases should be used. In addition, the temperature stability of the bearing and premature seal failure should be taken into consideration. In electric machines, bearings often operate at temperatures close to 100 °C. Under certain conditions, SKF LGHP 2 grease is a suitable selection (→ **diagram 2**, **page 60**).

For high temperature applications please consult the SKF application engineering service.

#### Vertical shaft

For bearings on vertical shafts, the intervals obtained from **diagram 3**, **page 65**, should be halved. The use of a good seal or retaining shield is a prerequisite to prevent grease leaking from the bearing arrangement.

Table 4

Bearing factors and recommended limits for speed factor A				
Bearing type <sup>1)</sup>	Bearing factor $b_f$	Recommended limits for speed factor A for load ratio		
		C/P ≥ 15	C/P ≈ 8	C/P ≈ 4
–	–	mm/min		
<b>Deep groove ball bearings</b>	1	500 000	400 000	300 000
<b>Angular contact ball bearings</b>	1	500 000	400 000	300 000
<b>Self aligning ball bearings</b>	1	500 000	400 000	300 000
<b>Cylindrical roller bearings</b>				
– non-locating, bearing	1,5	450 000	300 000	150 000
– locating bearing, without external axial loads or with light but alternating axial loads	2	300 000	200 000	100 000
– locating bearing, with constantly acting light axial load	4	200 000	120 000	60 000
– without cage, full complement <sup>2)</sup>	4	NA <sup>3)</sup>	NA <sup>3)</sup>	20 000
<b>Taper roller bearings</b>	2	350 000	300 000	200 000
<b>Needle roller bearings</b>	3	350 000	200 000	100 000
<b>Spherical roller bearings</b>				
– when load ratio $F_a/F_r < e$ and $d_m \leq 800$ mm				
series 213, 222, 238, 239	2	350 000	200 000	100 000
series 223, 230, 231, 232, 240, 248, 249	2	250 000	150 000	80 000
series 241	2	150 000	80 000 <sup>4)</sup>	50 000 <sup>4)</sup>
– when load ratio $F_a/F_r < e$ and $d_m > 800$ mm				
series 238, 239	2	230 000	130 000	65 000
series 230, 231, 232, 240, 248, 249	2	170 000	100 000	50 000
series 241	2	100 000	50 000 <sup>4)</sup>	30 000 <sup>4)</sup>
– when load ratio $F_a/F_r > e$				
all series	6	150 000	50 000 <sup>4)</sup>	30 000 <sup>4)</sup>
<b>CARB toroidal roller bearings</b>				
– with cage	2	350 000	200 000	100 000
– without cage, full complement <sup>2)</sup>	4	NA <sup>3)</sup>	NA <sup>3)</sup>	20 000
<b>Thrust ball bearings</b>	2	200 000	150 000	100 000
<b>Cylindrical roller thrust bearings</b>	10	100 000	60 000	30 000
<b>Spherical roller thrust bearings</b>				
– pure axial load and rotating shaft washer	4	200 000	170 000	150 000

<sup>1)</sup> The bearing speed factors and recommended maximum speed apply to bearings with standard internal geometry and standard cage execution.

For alternative internal bearing design and special cage execution, please ask SKF for advice

<sup>2)</sup> The  $t_f$  value obtained from **diagram 1** needs to be divided by the factor 10

<sup>3)</sup> Not applicable, for these C/P values a caged bearing is recommended instead

<sup>4)</sup> For higher speeds oil lubrication is recommended

## 4 Lubrication and sealing

### Relubrication intervals

#### Vibration

Moderate vibration will not have a negative effect on grease life, but high vibration and shock levels, such as those in vibrating screen applications, will cause the grease to churn. In these cases the relubrication interval should be reduced. If the grease becomes too soft, grease with a better mechanical stability or grease with higher stiffness up to NLGI 3 should be used.

#### Outer ring rotation

In applications where the outer ring rotates, the speed factor A is calculated differently: in this case use the bearing outside diameter D instead of  $d_m$ . The use of a good sealing mechanism is a prerequisite in order to avoid grease loss.

For applications where there are high outer ring speeds (i.e. > 40 % of the reference speed listed in the product tables), greases with a reduced bleeding tendency should be selected.

For spherical roller thrust bearings with a rotating housing washer, oil lubrication is recommended.

#### Contamination

In case of ingress of contamination, more frequent relubrication than indicated by the relubrication interval will reduce the number of foreign particles, hence reducing the damaging effects caused by the over rolling of these particles. Fluid contaminants (water, process fluids) also call for a reduced interval. In case of severe contamination, continuous relubrication should be considered.

#### Very low speeds

Selecting the proper grease and grease fill is very important in low speed applications.

Bearings that operate at very slow speeds under light loads require a low consistency grease. Bearings that operate at slow speeds under heavy loads need a high viscosity grease with very good EP characteristics. Grease viscosity should be selected according to the procedures described in the SKF General Catalogue.

#### High speeds

Relubrication intervals for bearings used at high speeds i.e. above the recommended speed factor A given in **table 4**, only apply when using special greases or modified bearing executions, e.g. hybrid bearings. In these cases continuous relubrication techniques such as circulating oil, oil air mixture etc, are more suitable than grease lubrication.

#### Cylindrical roller bearings

The relubrication intervals from **diagram 3**, **page 65**, are valid for cylindrical roller bearings fitted with

- an injection moulded cage of fibre reinforced polyamide 6,6, designation suffix P
- a roller guided two-piece machined brass cage, designation suffix M.

For bearings with a pressed steel cage, designation suffix J or shoulder guided cages, designation suffixes MA, ML and MP, the value for the relubrication interval from **diagram 3** should be halved. Moreover grease with good oil bleeding properties should be applied.

## 4 Lubrication and sealing

### Relubrication intervals

#### Observations

If the determined value for the relubrication interval  $t_f$  is too short for a particular application, it is recommended to

- check the bearing operating temperature,
- check whether the grease is contaminated by solid particles or fluids,
- check the bearing application conditions such as load or misalignment

and, last but not least, a more suitable grease should be considered.

#### Grease escape valve

When a bearing rotates at high speed and needs frequent relubrication, excessive grease can accumulate in the housing and cause temperature peaks, which will have a detrimental effect on the grease as well as on bearing service life. In these cases it is advisable to use a grease escape valve. This prevents over-lubrication and allows relubrication to be performed while the machine is in operation. The typical valve consists of a disc rotating with the shaft, forming a narrow gap at the housing end cover.

#### Grease escape valve

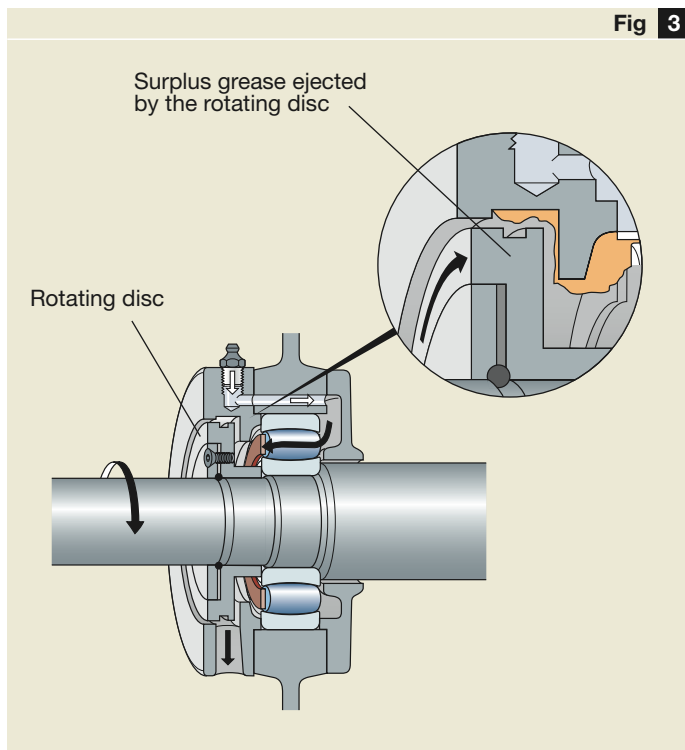

Fig 3

Table 5

#### Bearing housing with grease escape valve

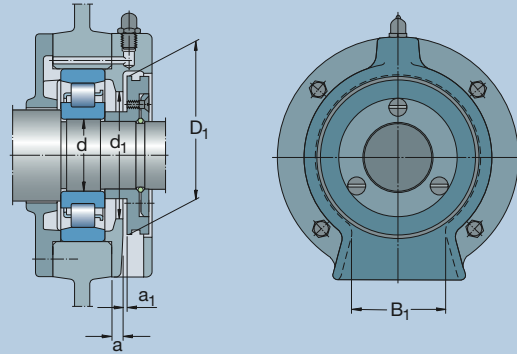

Illustration shows only principle, the size of left and right picture are not the same

Bore diameter Diameter Series		Dimensions				
2	3	d <sub>1</sub>	D <sub>1</sub>	B <sub>1</sub> min	a	a <sub>1</sub> ≈
d		mm				
30	25	46	58	30	6 – 12	1,5
35	30	53	65	34	6 – 12	1,5
40	35	60	75	38	6 – 12	1,5
45	40	65	80	40	6 – 12	1,5
50	45	72	88	45	8 – 15	2
55	50	80	98	50	8 – 15	2
60	55	87	105	55	8 – 15	2
65	60	95	115	60	8 – 15	2
70	–	98	120	60	10 – 20	2
75	65	103	125	65	10 – 20	2
80	70	110	135	70	10 – 20	2
85	75	120	145	75	10 – 20	2
90	80	125	150	75	10 – 20	2
95	85	135	165	85	10 – 20	2
100	90	140	170	85	12 – 25	2,5
105	95	150	180	90	12 – 25	2,5
110	100	155	190	95	12 – 25	2,5
120	105	165	200	100	12 – 25	2,5
–	110	175	210	105	12 – 25	2,5
130	–	180	220	110	15 – 30	2,5
140	120	195	240	120	15 – 30	2,5
150	130	210	260	130	15 – 30	2,5
160	140	225	270	135	15 – 30	2,5
170	150	240	290	145	15 – 30	2,5
180	160	250	300	150	20 – 35	3
190	170	265	320	160	20 – 35	3
200	180	280	340	170	20 – 35	3
–	190	295	360	180	20 – 40	3
220	200	310	380	190	20 – 40	3
240	220	340	410	205	20 – 40	3
260	240	370	450	225	25 – 50	3
280	260	395	480	240	25 – 50	3
300	280	425	510	255	25 – 50	3



## 4 Lubrication and sealing

### Relubrication intervals



Fig 4

The automatic lubricator SYSTEM 24

The automatic lubricator SYSTEM MultiPoint



Fig 5

Excess grease is collected by the disc, then discharged into a cavity in the end cover, and ejected through an opening on the underside of the bearing housing. The grease valve principle is shown in **fig 3** and **table 5** gives dimension recommendations.

### Automatic lubricator SYSTEM 24

SKF SYSTEM 24 is an automatic lubricator yielding a constant grease flow that can be adjusted by setting a dial for required lubricant flow rate. It is specially designed to provide a reliable and economical alternative to the traditional manual greasing method (→ **fig 4**).

### Multipoint lubricator SYSTEM MultiPoint

The SKF SYSTEM MultiPoint lubricator is an electromechanical device that can feed up to eight lines (→ **fig 5**). It is also suitable for applications that need longer feed lines or higher feed pressures. Typical applications include large electric motors, pump and motor combinations.

## 4 Lubrication and sealing

### Grease life in sealed bearings

## Grease life in sealed bearings

Modern SKF greases often perform better at high speeds and high temperatures than the standard lithium based mineral oil greases, on which the relubrication interval diagram is based. Therefore SKF recommends separate grease life diagrams for sealed SKF bearings that are lubricated for life.

### Grease performance factor

In **diagram 4**, a “grease performance factor” (GPF) is introduced as a way to take improved high speed, high temperature performance into account. The standard SKF grease has a GPF = 1.

In cases where the required grease life can not be achieved using a standard SKF grease, a special SKF grease with a higher GPF can be used. However, grease life depends also on the bearing load. The values obtained from **diagram 4** are valid for load conditions  $C/P = 15$ . For higher loads, the value of the grease life needs to be adjusted. Values for the adjustment factor are given in **table 7**. See **table 6** for grease performance factors of SKF selected greases.

However, it is important to note that grease performance factors are valid only for the specified temperature and speed ranges for that grease (→ **table 1**, **page 62**). Greases with GPF >1 have an advantage at elevated

*Grease life in lubricated-for-life deep groove ball bearings with steel shields and metal cages, running at low loads*

Diagram 4

$L_{10}$  (h) as function of  $n \times d_m$ , temperature and grease type (GPF = 1, 2, 4, resp.)

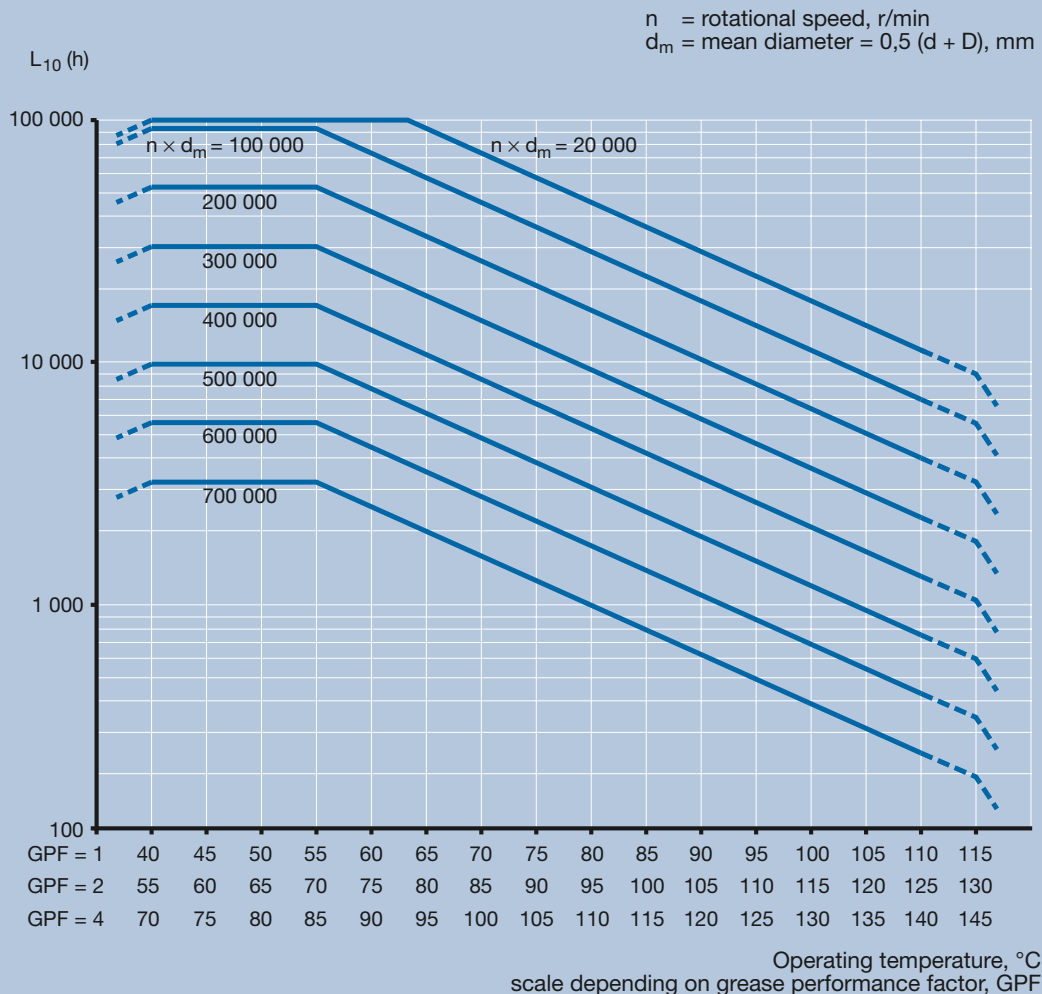

## 4 Lubrication and sealing

### Grease life in sealed bearings

temperatures, but might not release adequate amounts of oil at lower temperatures. For this reason using the GPF outside the range of **diagram 4** is not recommended.

#### Deep groove ball bearings

**Diagram 4** is valid for deep groove ball bearings with steel shields and metal cages. It applies to bearings that are filled and capped under clean conditions in an SKF factory with a normal quantity of one of the standard factory fill greases.

The grease life is presented as  $L_{10}$ , i.e. the time period at the end of which 90 % of the bearings are still reliably lubricated.

The grease life diagram gives the option to assess the life for special greases with  $GPF = 2$  or  $GPF = 4$ , by using the corresponding temperature scales on the horizontal axis of **diagram 4**.

For grease life calculations related to deep groove ball bearings with other seals, cages, or other special bearing executions, SKF should be consulted.

#### Grease performance factors for SKF standard and selected greases

Table 6

Specification of grease performance factors for SKF bearings with factory fill		
Factor	Grease suffixes	Maximum $n \times d_m$
GPF = 1	no suffix	500 000
GPF = 1	MT47, MT33	500 000
GPF = 1	LT	700 000
GPF = 2	GJN, LHT23, HT	500 000
GPF = 4	WT	700 000

#### Grease life in sealed deep groove ball bearings – life reduction factor for increased loads

Table 7

With increased relative load, the grease life needs to be adjusted	
Relative load as C/P	Approximate factor
$\geq 15$	1,0
10	0,7
8	0,5
4	0,2

## Oil lubrication

Oil is typically selected as a lubricant when rotational speeds or operating temperatures make it impractical or impossible to use grease. In applications where there are high operating temperatures, recirculating oil systems are used to dissipate heat. Recirculating systems can also be used to remove and filter out contaminants.

Oil lubrication requires more sophisticated seals and there could be a risk of leakage.

In general only large electric motors and generators are oil lubricated.

### Oil bath lubrication

For large electric machines, SKF has developed a range of flanged housing units equipped with rolling bearings (→ **fig 6**).

The new bearing system is normally oil bath lubricated and can be equipped with an oil leveller to maintain the correct oil level in the bearings (the oil level almost reaches the centre of the lowest rolling element when the bearing is stationary) (→ section “Large and very large electric machines”, **pages 109 and 110**).

### Circulating oil

For applications that have a very high normal operating temperature, an oil recirculation system can be used to remove heat. These systems typically have a filtering system that removes contaminants from the fluid, which prolongs the life of the lubricant and the service life of the bearings.

### Selecting a lubricating oil

Oil selection is based primarily on the viscosity required to provide adequate lubrication for the bearing at normal operating temperature. The viscosity of oil is temperature dependent and the viscosity-temperature relationship of oil is characterized by the viscosity index VI. For rolling bearings, oils having a high viscosity index of at least 85 are recommended.

In order to form a sufficiently thick oil film in the contact area between the rolling elements and raceways, the oil must retain a minimum viscosity at the normal operating temperature. The rated kinematic viscosity required at

the normal operating temperature can be determined from **diagram 5**, provided a mineral oil is used. When the operating temperature is known from experience or simulation, the corresponding viscosity at the internationally standardized reference temperature of 40 °C can be obtained from **diagram 6**, which is compiled for a viscosity index of 95.

### Oil change

The frequency with which it is necessary to change oil depends mainly on the operating conditions and the quantity of oil.

*A flanged housing unit with a CARB toroidal roller bearing*

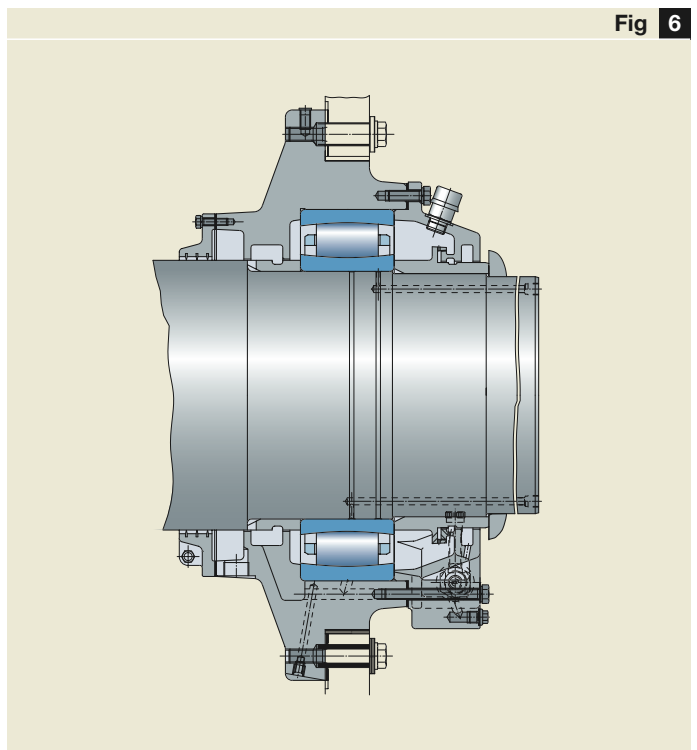
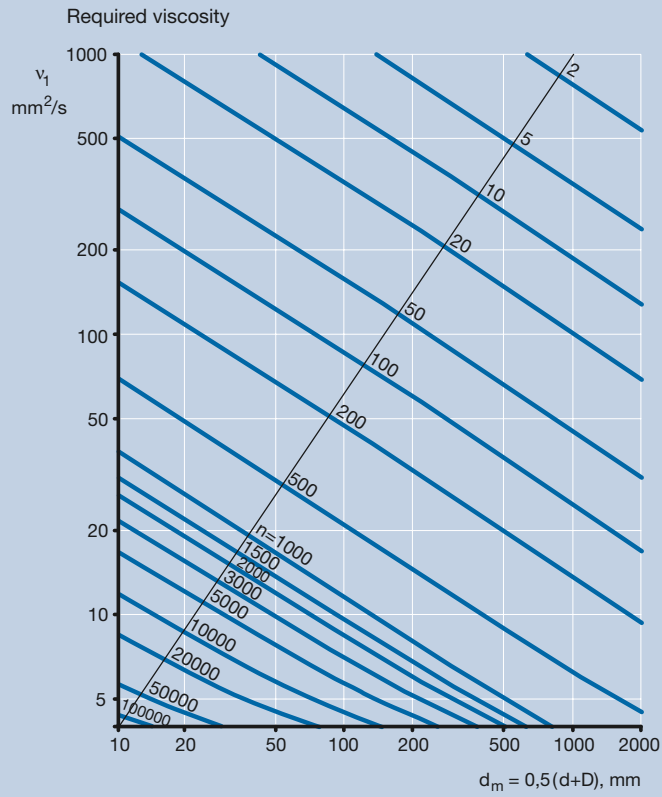

Diagram 5

Estimation of the rated viscosity  $v_1$  required for adequate lubrication



4

Diagram 6

Estimation of the actual operating viscosity  $v$

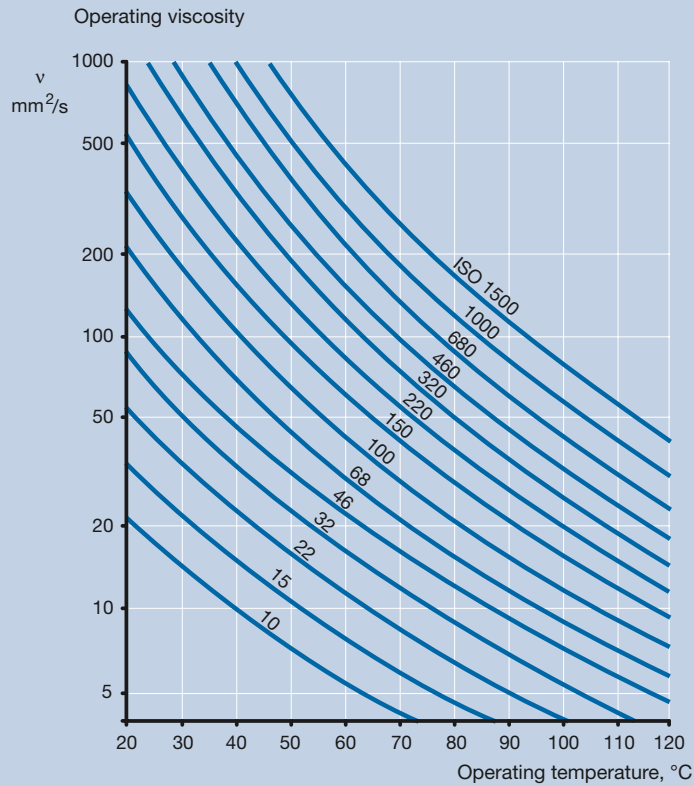

## Seals

The purpose of a seal is to protect the internal environment of an application by retaining lubricant and protecting the bearings from external contaminants like dirt and moisture. The type of seals to select for an application typically depends on both the operating and environmental conditions. Factors include:

- environment
- type of lubricant
- sliding velocity of the sealing surface
- whether the seal is to be mounted vertically or horizontally
- the extent of misalignment

Environmental conditions also include:

- presence of chemicals or water
- thermal conditions
- mechanical factors

which can influence sealing performance. Seals can be divided into external seals and internal seals, i.e. seals integrated within the bearing.

### External seals

SKF offers a wide range of seals, including:

- radial shaft seals
- V-ring seals
- mechanical seals

These and other external sealing solutions are described in detail in the catalogue 4006 E “CR seals”, or the SKF Interactive Engineering Catalogue. **Fig 7** shows an example of an external seal.

### Internal seals – sealed deep groove ball bearings

SKF offers three different sealing arrangements for deep groove ball bearings. The type you choose depends on the application, bearing size and series. For the latest information on the availability of any preferred sealing arrangement please contact the local SKF representative.

The three standard sealing solutions are:

- 2Z metallic shields (→ **fig 8**): typical applications are catalogue motors with a limited demand for dust and water exclusion but requiring a low friction sealing solution.
- 2RSL light contacting seal (available up to a 52 mm outside diameter) and 2RZ low friction seals (→ **fig 9**): typical applications for these seals are low torque motors, high speed motors, DC machines. These seals have good sealing and grease retention properties and does not affect the speed rating of the bearing.
- 2RSH (available up to a 52 mm outside diameter) and 2RS1 contact seals (→ **fig 10**): typical applications are open motors, DC machines and geared motors.

### Seal materials

A variety of seal materials are available to meet specific application requirements such as operating temperature and compatibility with greases, oils or any other materials.

The standard seal for an SKF deep groove ball bearing is made from acrylonitrile butadiene rubber (NBR). The seal material is compatible with grease, oil and other standard machinery fluids

Fig 7

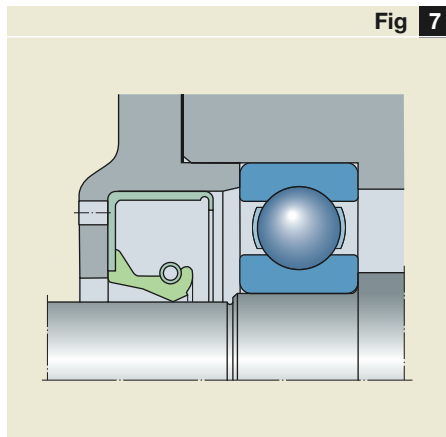
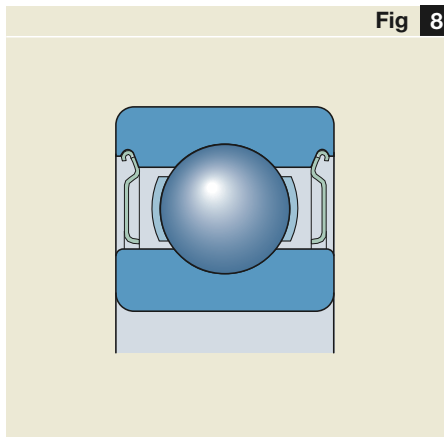

Fig 8



Bearing with metallic shields – 2Z

## 4 Lubrication and sealing Seals

Fig 9

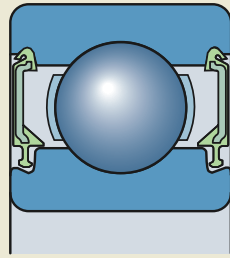

a

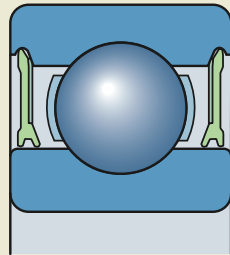

b

- a) Bearing with 2RSL low friction seals
- b) Bearing with 2RZ low friction seals

and can be used effectively when normal operating temperatures range between  $-40$  to  $+100$  °C ( $-40$  to  $+210$  °F) and for brief periods temperatures of up to  $120$  °C ( $248$  °F) can be tolerated. Another seal material which is commonly used in more aggressive (chemical) environments and high temperature applications is a fluoro-carbon rubber (FKM), known as Viton. Viton can be used in applications where normal operating temperatures range from  $-30$  to  $+180$  °C ( $-22$  to  $+350$  °F).

Fig 10

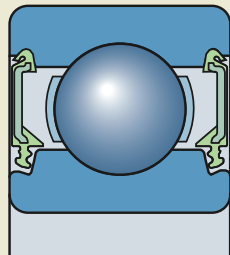

a

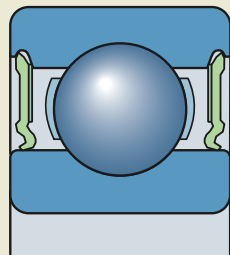

b

- a) Bearing with 2RSH contact seals
- b) Bearing with 2RS1 contact seals

**5 Mounting and dismounting**

**Mounting** ..... 77

**Dismounting** ..... 85





# Mounting and dismounting

Rolling bearings are precision products that must be handled carefully during mounting if they are to perform properly.

A variety of factors – incorrect mounting techniques or methods, dirty hands or tools, contaminated grease or oil – can cause bearing damage. Regardless of the quality level of the bearing or seal, these factors can quickly lead to bearing failure.

## Mounting

### Preparations before mounting

A clean working surface, correct mounting methods and appropriate tools are essential elements of a successful bearing installation. The mounting environment needs to be absolutely clean and free from any contaminants or corrosive fluids that might damage the bearing. Contaminants include but are not limited to metal particles, saw dust, sand and cement. If the mounting process is discontinued for any reason, the bearing should be protected immediately so that dust and dirt can not enter the bearing cavity (→ fig 1, page 78).

## 5 Mounting and dismounting

### Mounting

Keep the work area clean

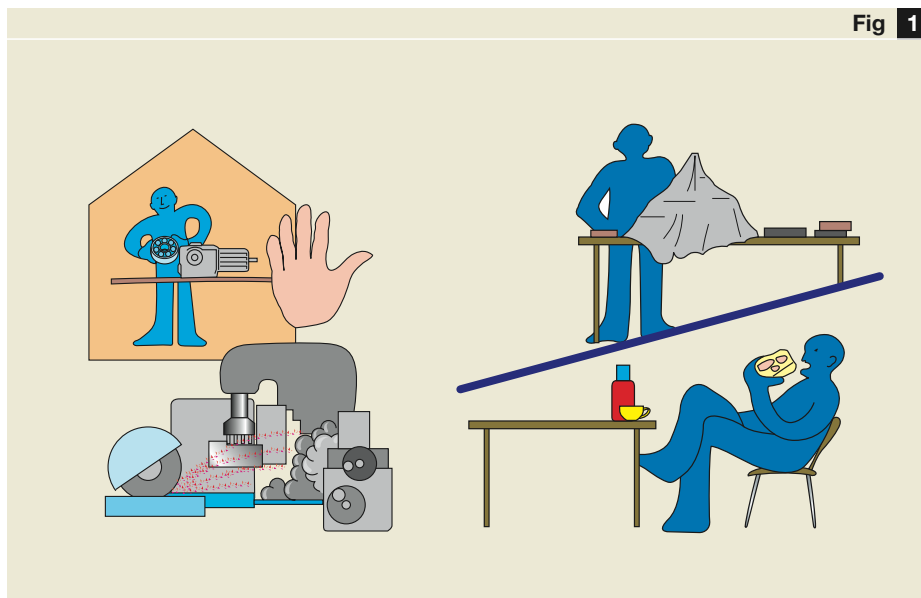

#### Check the shaft and housing

Prior to an installation, always check the shaft and housing seatings for any damage that may have occurred. Be sure that the seating dimensions and form accuracy correspond to the specifications (→ **fig 2**) and/or applicable SKF recommendations (→ **chapter 3** “Tolerances and fits”, starting on **page 51**).

#### How to measure

The shaft and housing seatings and their cylindricity can be checked by measuring the diameter in two cross-sections and in four planes by using outside and inside micrometers. In order to check the seatings properly

it is necessary to make the measurements as shown in **fig 3**.

If, for example, a 40 mm diameter shaft has a k6 tolerance, the maximum diameter is 40,018 mm; the minimum diameter is 40,002 for a tolerance grade of IT6 or 0,016. However, cylindricity requires that the variation of the radius between the shaft and seat should not exceed IT5/2 (0,011/2) or 0,0055 mm.

Check the shaft for wear or damage. The shaft and housing seatings need to be checked for straightness and abutments for perpendicularity. Straight edges and dial gauges can be used for this. Whenever there is reason to suspect that the radial and axial run-outs are not appropriate, they should be checked as well.



Checking the shaft

## 5 Mounting and dismounting

### Mounting

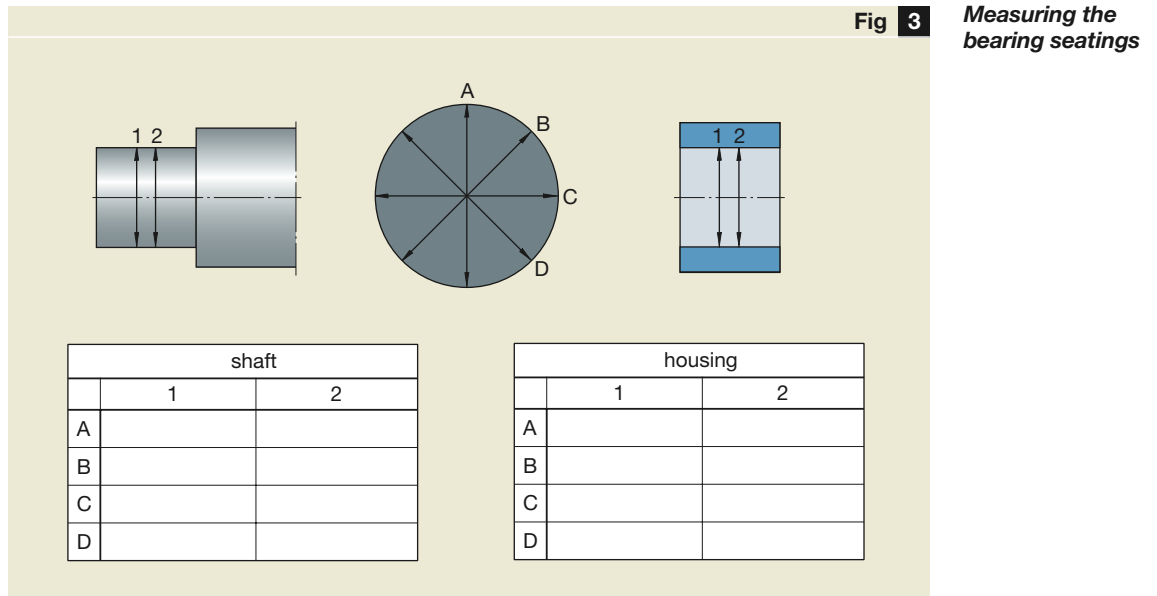

Check the assembly drawings for specifications. Record the measurements for future reference.

#### Handling bearings

New SKF bearings are well protected in their package. Do not remove them from the package until immediately before mounting.

All surfaces of a new bearing are covered with a rust-inhibiting preservative that should not be removed unless it is incompatible with the grease or oil being used. If the preservative is not compatible with the lubricant, wash the bearing carefully. Dry the bore and outside diameter with a lint-free cloth.

## 5 Mounting and dismounting

### Mounting

Fig 4

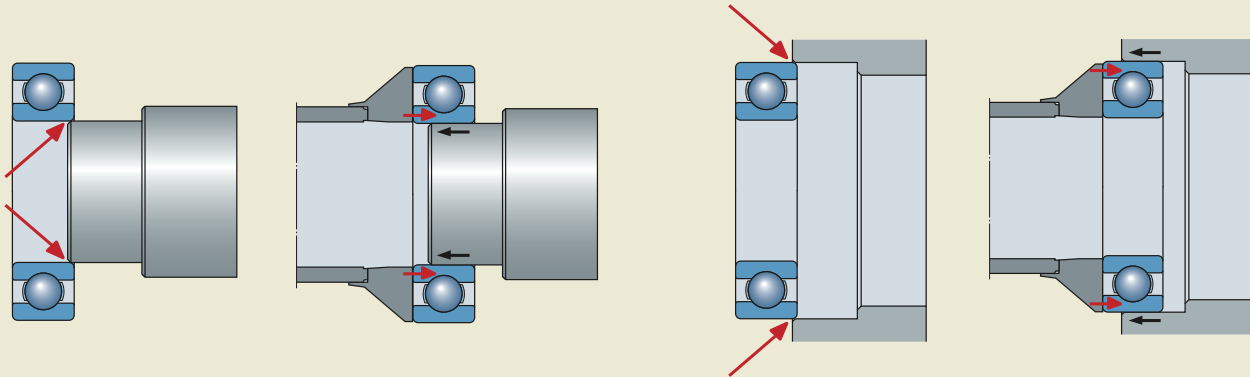

mounting an inner ring with an interference fit

mounting an outer ring with an interference fit

**The right method for cold mounting bearings with an interference fit**

### Cold mounting

Bearings up to approximately 100 mm bore can be mounted onto a shaft without heat. Mounting a bearing cold is not difficult and will not have an effect on bearing service life provided it is installed properly; with the correct tools.

### Appropriate method

To cold mount a bearing, apply a thin film of light oil to the bearing seating. Then gently position the bearing so that it lines up with the shaft. Position the mounting tool and apply the mounting force to the bearing ring being mounted with an interference fit (→ fig 4).

Applying the mounting force to the other ring only, will transfer the mounting force through the rolling elements

to damage the bearing and substantially decrease bearing service life.

### Appropriate tools

Small bearings, with a bore diameter up to approximately 50 mm, can best be cold mounted by using the SKF TMFT fitting tools (→ figs 5 and 6).

Medium size bearings with a bore diameter less than 100 mm are usually cold mounted with a mechanical or hydraulic press. To do this, a sleeve must be placed between the press and the bearing ring being mounted with an interference fit (→ fig 7).

**Appropriate tools for cold mounting – the SKF TMFT series fitting tools, figs 5 and 6**

**Cold mounting with a press**

Fig 5



Fig 6



Fig 7

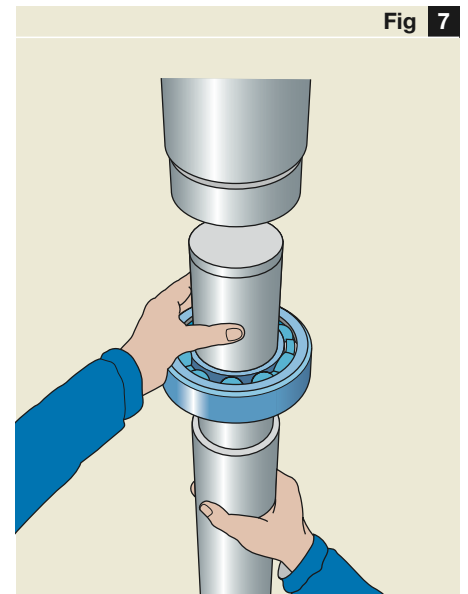

## 5 Mounting and dismounting

### Mounting

Electric hot plate



### Hot mounting

The required force needed to mount a bearing increases rapidly with bearing size. Larger bearings cannot be pressed easily onto a shaft or into a housing because of the mounting force required. Therefore if there is an interference fit between the bearing and shaft, the bearing should be heated. If the interference fit is between the bearing and housing, the housing should be heated.

The requisite temperature difference between the bearing and its seating depends on the magnitude of the interference fit and the bearing size.

Normally a bearing temperature of 80 to 90 °C (175 to 195 °F) higher than that of the shaft is sufficient for mounting. Never heat a bearing to a temperature greater than 125 °C (255 °F). Overheating may alter the bearing metallurgically and dimensionally. Local overheating must be avoided.

Wear clean protective gloves when mounting a hot bearing. Lifting (hoisting) gear can facilitate mounting. Push the bearing onto the shaft until it is pressed firmly against the abutment. Hold the bearing in place against the abutment until the bearing cools and forms a tight fit onto the bearing seating.

### Appropriate tools

SKF has a full line of heating tools, such as electric hot plates and induction heaters. An electric hot plate (→ fig 8), with adjustable thermostat and cover,

Induction heater



is used for smaller size bearings. An induction heater (→ fig 9) is used for medium and larger size bearings. Induction heaters, which are generally equipped with adjustable thermostats and automatic demagnetisation, are extremely easy to use.

When an interference fit is required between the bearing and housing, a moderate increase in housing temperature is required. In most cases, a temperature increase of 20 to 50 °C (70 to 120 °F) is sufficient because the interference fit is usually light. Another option is to cool the bearing before it is mounted into the housing.

### Important!

- Do not heat a bearing using an open flame.
- Sealed bearings (contact seals or shields) should not be heated over 80 °C (176 °F) because of their grease fill and because damage to the seal material could result.

## 5 Mounting and dismounting

### Mounting

#### Additional consideration

There are several aspects to consider when mounting bearings. Some of the more basic ones are listed below:

- Keep the bearing clean.
- Make sure that the bearing is mounted at a right angle onto the shaft.
- Apply the mounting force to the appropriate ring.
- Handle the bearings with care.

#### Non-separable bearings

The non-separable bearing types used in electric motors are deep groove ball bearings, single row angular contact ball bearings, CARB toroidal roller bearings and spherical roller bearings.

When an interference fit is required for the inner ring, first mount the bearing onto the shaft. Then carefully assemble the housing and bearing and shaft assembly (→ **fig 10a**).

INSOCOAT and hybrid bearings are mounted in the same manner as the basic bearing type.

When a CARB bearing is mounted with an interference fit on a shaft, use a tool that will support both the inner and outer rings (→ **fig 10b**).

#### Separable bearings

Cylindrical roller bearings are the only separable radial bearings used in electric motors (→ **fig 11**). Because these bearings are typically mounted with an interference fit on both the shaft and in the housing, the rings are usually mounted separately.

The rollers in a single row cylindrical roller bearing are axially guided between integral flanges on one of the bearing rings. The flanged ring and the roller and cage assembly form a unit that can be separated from the other ring. This separable feature facilitates mounting. Mount the separable ring first.

When mounting the inner ring of a cylindrical roller bearing, an induction heater might be necessary. The outer ring is usually just pressed into the housing.

Apply lubricant to the cage and roller assembly of the other ring. Make sure the lubricant also reaches the raceway. Also apply a thin layer of lubricant to the raceway of the other ring.

When assembling, make sure that the roller assembly is not at an angle to the other ring. If either part of the bearing is assembled at an angle, it is easy to damage a ring or rollers, especially if the rollers or raceways are not lubricated. To avoid this kind of problem it is recommended to use a guiding sleeve (→ **fig 11**). To help prevent the rollers from scratching the raceway of the other ring, the rings need to be rotated relative to each other as the bearing is being assembled.

#### Checking the alignment

For a cylindrical roller bearing to achieve maximum service life, misalignment between the shaft and housing should be avoided.

For large bearings the alignment between the inner and outer rings can be

#### Mounting non-separable bearings

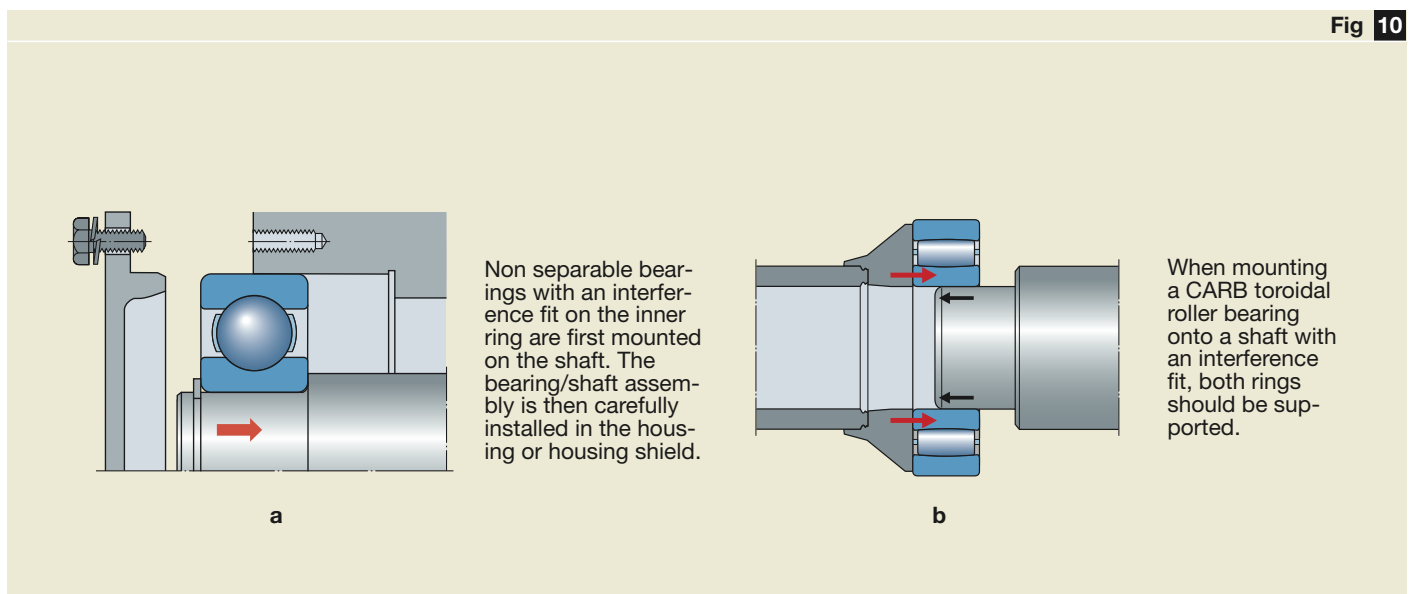

## 5 Mounting and dismounting

### Mounting

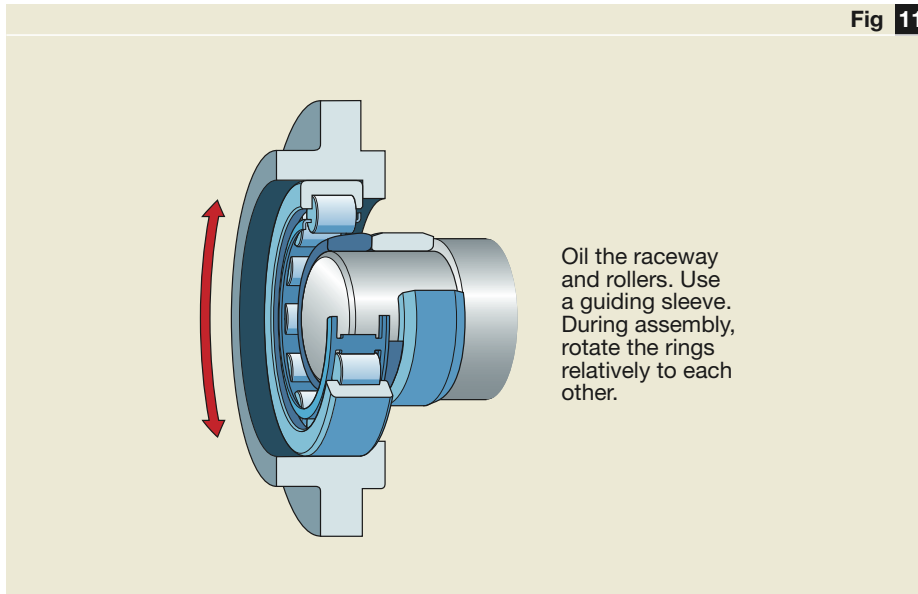

Fig 11

*Mounting of separable bearings*

Oil the raceway and rollers. Use a guiding sleeve. During assembly, rotate the rings relatively to each other.

checked with the tool shown in **fig 12**, once the bearing and shaft assembly has been properly installed in the housing. The tool consists of a dial indicator mounted on a steel segment. This steel segment has two set screws for height adjustment, and to provide two solid contact points with the shaft. The steel segment is pressed against the side face of the inner ring and the shaft. The gauge is directed against the side surface of the bearing outer ring.

To obtain a value for misalignment, first determine the maximum deviation  $d_x$  by measuring two points on the outer ring side face that are 180 degrees apart. The misalignment angle can then be calculated from:

$$\beta = 3\,438 \frac{d_x}{D}$$

where

$\beta$  = misalignment angle, minutes of arc

$d_x$  = maximum deviation, mm

$D$  = bearing outside diameter, mm

The maximum allowable value for the angle of misalignment  $\beta$  is 4 minutes of arc.

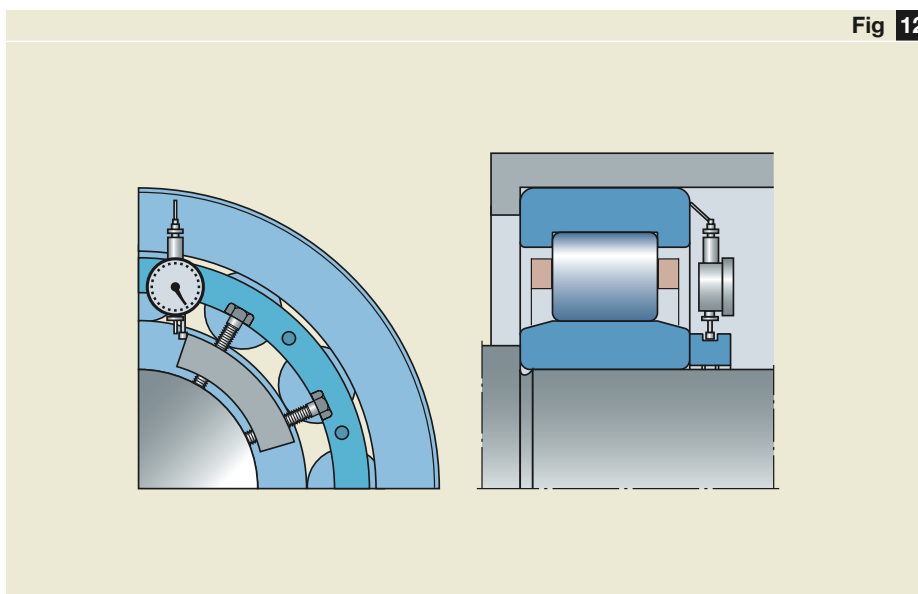

Fig 12

*Tool for checking alignment*

## 5 Mounting and dismounting

### Mounting

#### Lubricating the bearings

Grease lubricated open bearings should be greased after they have been mounted onto the rotor (→ **fig 13**).

- For cylindrical roller bearings, the interior space of the cage and roller assembly should be filled immediately after it is mounted. Grease is also applied to the raceway of the free ring immediately after it has been installed. Only then should the bearing be assembled.
- Non-separable bearings, due to lack of space, are filled with grease from the front. Use an SKF grease packer, for example, and check that the grease has penetrated through the bearing, to be sure that the bearing cavity is completely filled.
- Do not fill all the free space in the housing. The grease fill should not exceed 30–50 % of the free space.
- Make sure that the grease is free from contaminants.
- For oil lubricated bearings, fill the housing with fresh, clean oil.

#### More information

General information about mounting bearings can be found in the SKF General Catalogue, or in the SKF Interactive Engineering Catalogue on CD-ROM or online at [www.skf.com](http://www.skf.com). Further information can also be found in the SKF Bearing Maintenance Handbook. Information about mounting a specific type of bearing can be obtained online at [www.skf.com/mount](http://www.skf.com/mount).

#### Procedures after mounting

If the motor is to be tested after assembly, a load should be applied to the rotor so as not to damage the bearings (→ **fig 14**).

Only deep groove ball bearings can be run without an external load provided the bearings are spring loaded in the axial direction.

To make a final check of the motor assembly and to check the vibration levels in particular, SKF recommends use of SKF condition monitoring equipment (→ **fig 15**).



Fig 13

*Greasing bearings*



Fig 14

*Testing the motor*



Fig 15

*Vibration levels can be checked with SKF condition monitoring equipment*



## 5 Mounting and dismantling

### Dismounting

*Lock the shaft and the bearings before transport*



Fig 16

*Wrap the motor*



Fig 17

Before transportation, the bearings have to be locked radially and axially (→ fig 16). These precautions need to be made to prevent movement between the rolling elements and the raceways inside the bearing. Otherwise damage can be caused by vibrations during transportation.

Thoroughly wrap the motor for protection during transportation (→ fig 17).

## Dismounting

A number of points need to be observed when dismantling bearings:

1. Study assembly drawings to determine the bearing arrangement and make sure the proper dismantling tools are available.
2. Review the paper work to determine the cause of the rebuild.
3. Before initiating the dismantling procedure inspect the motor for signs of failure, e.g. leaks, arcing, broken fins
4. Clean the exterior of the motor and make sure the work area is clean.
5. Disassemble the motor without dismantling the bearings at this stage.
6. Inspect the bearings and seals looking for wear and damage.

Dismounting undamaged bearings should be avoided if possible as improper dismantling could cause internal bearing damage. If dismantling is necessary the bearings should be wrapped to avoid contamination. It is easier to prevent bearings from becoming dirty, than to clean them. Many bearings cannot be separated, making it very difficult to clean them.

7. Even if a bearing is to be replaced, dismantling should be done with care, to avoid further damage to the bearing and to the surrounding parts. If the bearing is damaged, examine it to determine the root cause of the damage and to take corrective action to avoid reoccurrence.
8. To dismount an undamaged bearing, mark its orientation and position on the shaft and make sure the shaft or the housing is supported properly during dismantling. Inappropriate dismantling can easily damage the raceways and rolling elements and shorten bearing service life.

An undamaged bearing should be remounted onto the shaft in the same orientation and in the same position as before dismantling.

## 5 Mounting and dismounting

### Dismounting

#### Standard jaw puller



Fig 18



Fig 19

#### Mechanical jaw puller with spring operated arms

### Dismounting methods

To dismount a bearing, apply force to the ring that needs to be removed, i.e. the ring with a tight fit.

For bearings in electric motors, there are four dismounting methods:

- using a mechanical puller
- using a hydraulic puller
- using a press
- using a heater

The method applied may depend on the bearing size. If the bearing is relatively small, a bearing puller may be used. However, medium and large size bearings may require a hydraulic puller.

Dismounting with heat is appropriate when removing the inner ring of cylindrical roller bearings.

#### Notches in the shaft facilitate dismounting

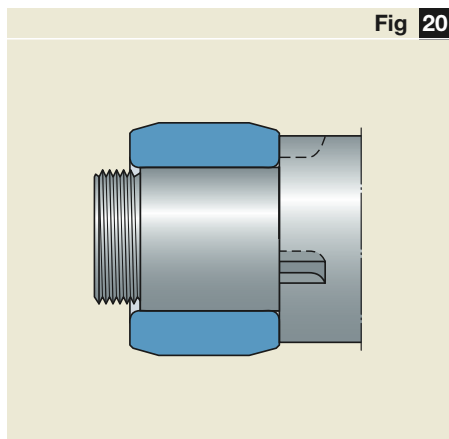

Fig 20

### Dismounting tools

Choosing appropriate tools for dismounting is crucial. For successful dismounting the most suitable tool for each individual case should be used.

#### Mechanical pullers.

Small and medium-size bearings mounted with an interference fit on the shaft can be dismounted using a conventional puller (→ fig 18). To eliminate the risk of damaging the bearing and/or bearing seating by applying uneven pressure during removal, always use self centering pullers. Therefore, for safe and easy dismounting SKF recommends using a puller in the TMMA series. They are self-centering and the unique spring operated arms facilitate the dismounting operation (→ fig 19).

If possible, let the puller engage the inner ring. This is facilitated if the shaft is provided with notches to engage the puller (→ fig 20). Remove the bearing with a steady pulling force until the bearing has been completely removed from its seating.

In applications where the inner ring is not accessible with normal jaw pullers, the bearing can be removed with a strong back puller (→ fig 21). Keep in mind however, that a strong back puller requires a certain amount of free space behind the bearing.

If it is not possible to apply force through the inner ring, the bearing can be removed via the outer ring. SKF does not recommend re-using a bear-

## 5 Mounting and dismounting

### Dismounting

ing after it has been removed in this way. If the bearing is to be analysed afterwards, or if there are other reasons to minimize bearing damage, the outer ring should be rotated during dismounting (→ **fig 22**). This can be done by locking the screw and continuously turning the puller while pulling until the bearing comes free.

Sometimes it is difficult to remove the outer ring from the housing due to fretting corrosion or housing deformation. In these cases, dismounting is facilitated if the housing was provided with tapped holes as shown in **fig 23**.

Sometimes neither the inner ring nor the outer ring are accessible. In these cases, special internal bearing pullers like the ones found in the SKF TMSC series or blind housing puller kits can be used (→ **fig 24**).



**Fig 21**

**Strong back puller**



**Fig 22**

**Minimize damage by rotating the outer ring**

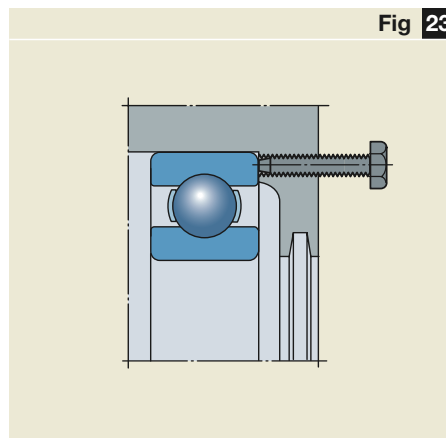

**Fig 23**

**Tapped holes in the housing facilitate dismounting of the outer ring**



**Fig 24**

**SKF blind housing puller**

## 5 Mounting and dismounting

### Dismounting

#### SKF hydraulic puller



Fig 25

#### Hydraulic pullers.

The force needed to dismount bearings having an interference fit on the shaft increases rapidly with the bearing size. To facilitate dismounting, hydraulic tools can be used for small and medium size bearings (→ fig 25).

Using a puller with an integrated hydraulic cylinder and pump will further facilitate the dismounting process.

#### Important!

It is dangerous to stand directly behind a hydraulic puller. When the bearing comes loose the puller can suddenly move backwards. Therefore, it is safer to stand to one side instead.

#### Removing the bearing using a press

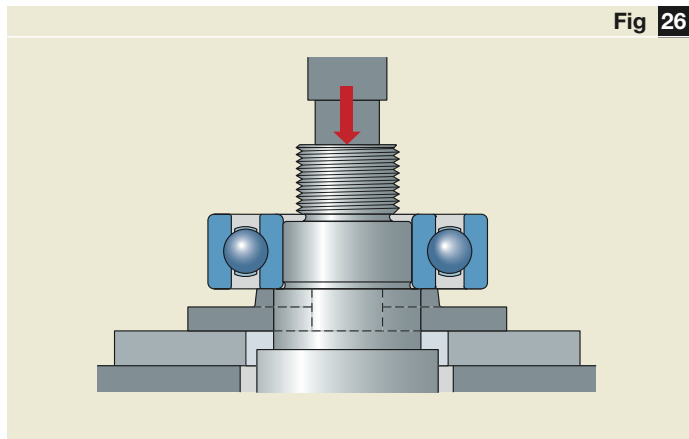

Fig 26

#### Presses

A convenient way to remove a bearing from the rotor shaft seating is by using a press (→ fig 26). Make sure, however, that only the bearing inner ring, having the interference fit, is supported.

#### Heaters

The inner ring of a cylindrical roller bearing is often removed with heat. To do this, SKF has developed a number of special tools including aluminium rings that are available for bearings in the NU, NJ and NUP series (→ fig 27).

The dismounting method is simple. Remove the outer ring and coat the inner ring raceway with a thick oxidation-resistant oil. Place the heating ring, pre-heated to about 280 °C (535 °F), around the inner ring and press the handles together. When the ring starts loosening, withdraw it from the shaft.

If dismounting inner rings of various diameters frequently, an SKF adjustable induction heater may be more convenient (→ fig 28).

#### Dismounting large bearings

To dismount large bearings normally the same methods can be applied as for smaller bearings.

However, the use of the oil injection method considerably facilitates dismounting. This presupposes that the necessary oil supply ducts and distributor grooves have been designed into the arrangement. Furthermore, hydraulically-assisted heavy duty jaw pullers are available, providing withdrawal forces up to 50 tonnes.

#### Aluminium heating ring

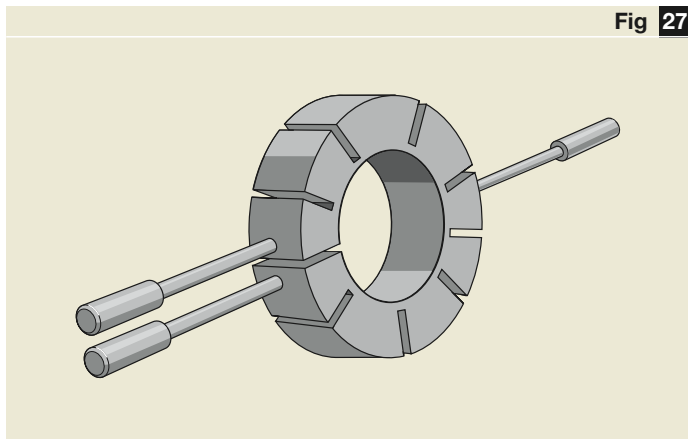

Fig 27

## 5 Mounting and dismantling

### Dismounting

*SKF adjustable  
induction heater*

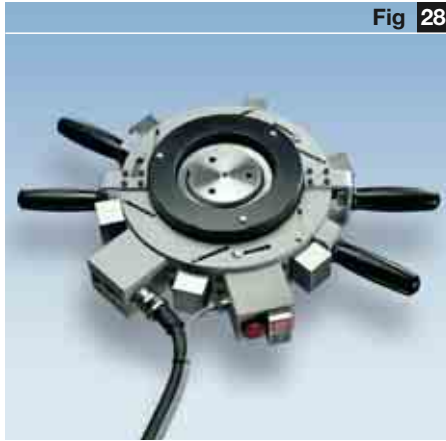

Fig 28

Use a lifting yoke, or similar lifting equipment, in combination with an SKF Bearing Handling Tool to facilitate the dismantling process (→ fig 29).

Further information about mounting and dismantling bearings can be found in the SKF General Catalogue or the SKF Interactive Engineering Catalogue on CD-ROM or online at [www.skf.com](http://www.skf.com), the SKF Bearing Maintenance Handbook and online at [www.skf.com/mount](http://www.skf.com/mount).



Fig 29

*SKF Bearing  
Handling Tool for  
medium and larger  
size bearings*

A close-up photograph of several SKF 6322 M/C4 ball bearings. The bearings are arranged in a stack, showing their outer rings, inner rings, and balls. The outer rings are made of a light-colored metal, likely steel, and have the SKF logo and model number '6322 M/C4' stamped on them. The inner rings are made of a darker metal, possibly brass or bronze, and have two small holes. The balls are visible between the rings. The background is a plain, light color.

## 6 Failure modes and corrective actions

Electrical erosion . . . . . 91

Inadequate lubrication . . . . 94

Bearing fatigue . . . . . 96

Damage from vibration . . . 96

Damage caused by  
improper installation  
and set-up . . . . . 97

Insufficient bearing load . . 99

Other damage . . . . . 99

VL 0241

# Failure modes and corrective actions

Bearings are key components of electric motors and must therefore meet exacting performance criterion in terms of load carrying capacity and reliability.

Today, SKF has the means to calculate bearing life with considerable accuracy, making it possible to match bearing life with the service life of the machine.

There are cases, however, where a bearing does not attain its calculated life and there can be a number of reasons – some more obvious than others.

Bearings in electric motors can fail prematurely for a number of different reasons including: heavier than expected loads, inadequate or unsuitable lubrication, too light loads, damage during transport or standstill, electrical erosion, mounting problems, improper handling, contaminants inside the bearing, ineffective seals, or improper shaft or housing fits.

Each of these factors produces its own particular type of damage and leaves its own special imprint on the bearing.

Consequently, by examining a damaged bearing it is possible in the majority of cases to determine the root cause of the damage so that the requisite actions can be taken to prevent a recurrence.

## Electrical erosion

The problem of an electric current passing through a bearing is common in electric motors and generators. This phenomenon, known as electric erosion or arcing, happens when a current passes from one raceway to the other through the rolling elements. The extent of the damage depends on the amount of energy and its duration. However, the result is usually the same: pitting damage to the rollers and raceways, rapid degradation of the lubricant and premature bearing failure.

Recently, with the increased use of frequency converters, there has been a dramatic increase in the number of

## 6 Failure modes and corrective actions

### Electrical erosion

bearing failures related to electrical erosion.

#### Typical bearing damage

##### Currents due to flux asymmetries

Due to manufacturing limitations it is impossible to obtain perfect electromagnetic symmetry.

Asymmetry leads to the generation of a flux of alternating magnitude, inducing a shaft voltage. This in turn leads to a circulating current flowing through the bearings. The problem occurs especially with large motors having a low number of pole pairs (e.g. 2-pole motors).

##### Currents due to unsymmetric cabling

The design and arrangement of the cabling on an electric motor or generator is a very important design consideration. Unsymmetric, non-shielded motor cabling can generate damaging currents (→ **fig 1**).

##### High frequency currents

New effects have been observed when a motor or generator is connected to a frequency converter.

The three phase output voltages from the converter are shaped as series of square pulses (not true sine waves). The sum of the three phase voltages is not zero, which creates a common mode voltage (→ **fig 2**).

Most modern frequency inverters try to simulate sine wave supply by Pulse Width Modulated (PWM) signals, using

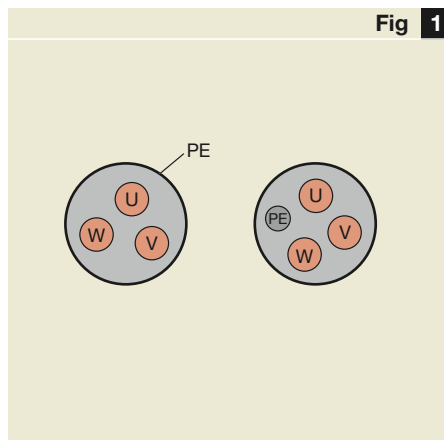

Fig 1

**Shielded and symmetric versus a non-shielded and unsymmetric cable**

newer transistor technology – integrated gate bi-polar transistors (IGBTs). These operate with not only high switching frequency (frequent pulses) but also with very fast voltage switches (steep-edged pulses). The speed of switching has increased rapidly (→ **fig 3**). These very steep-edged voltage pulses create high frequency current transients.

The condition is often referred to as “common mode noise”. The amplitude of these High Frequency (HF) currents varies with motor or generator size, converter type and cable parameters. Most of this HF current returns to the converter through the cable PE-lead and shield. But the remainder can cause trouble, and it is now known that both high switching frequency and high switching rate of rise are harmful.

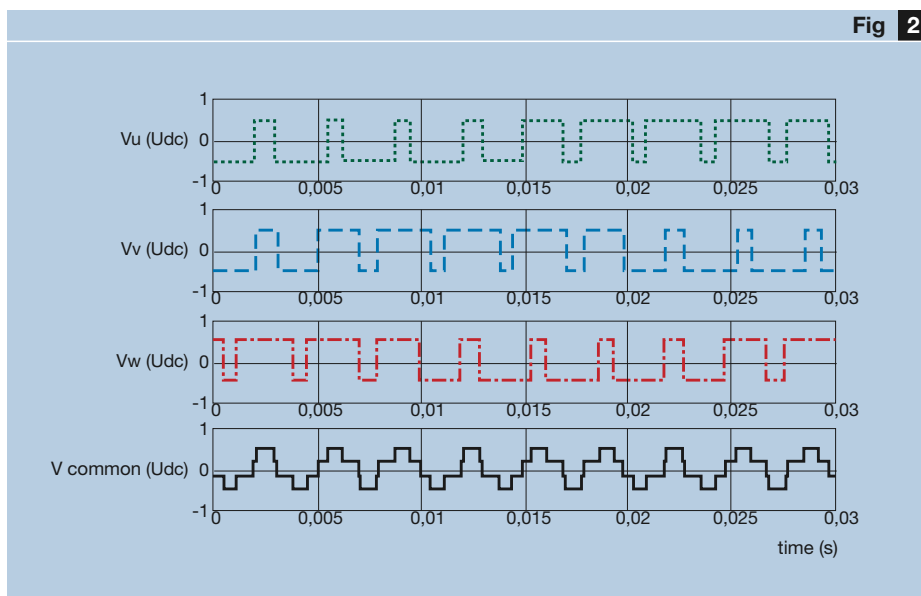

Fig 2

**The three phases and their sum is not zero – but leads to the common mode voltage**



## 6 Failure modes and corrective actions

### Electrical erosion

*Voltage pulse of a GTO transistor compared to a IGBT transistor*

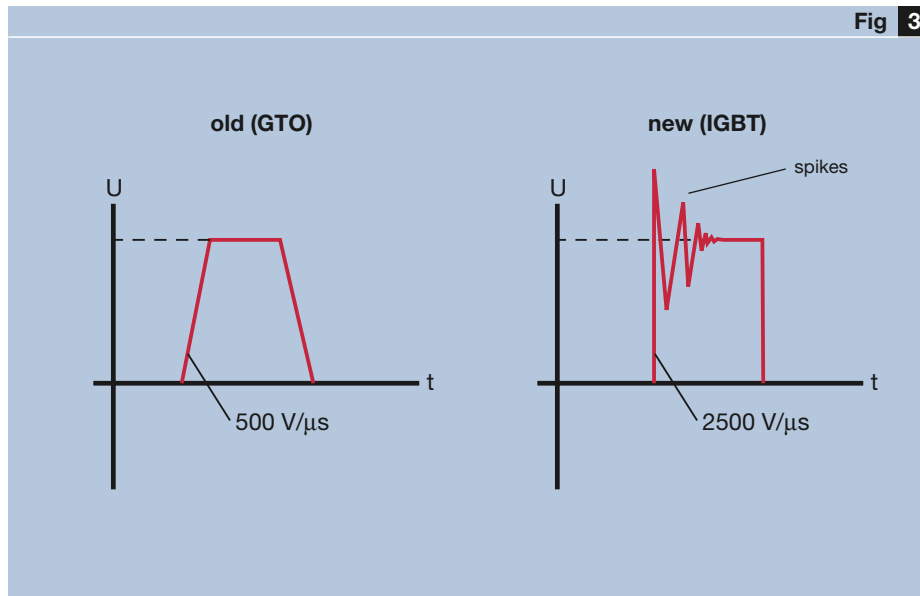

This means that in frequency converter drive systems, there is always a common mode voltage that can cause a current flow from the converter output terminals to ground. Also, it is not uncommon that the three phases are not fully symmetric, which creates further stator flux dissymmetry.

To sum up, there are three additional categories of bearing currents in converter drive systems:

- High frequency circulating currents
- High frequency shaft grounding currents
- Capacitive discharge currents

#### Effects of electric current going through the bearing

When an electric current passes through the contact zone of the rolling elements and raceway, the energy of the electric discharge generates heat, causing local melting of the surface.

Craters are formed in the contact area and small particles of melted material tend to break loose.

When the spark is gone, the material is re-hardened (typically 66 to 68 HRC) and is much more brittle than the original bearing material.

Below the re-hardened layer is a layer of material that was annealed by the heat. This material has become softer than the surrounding bearing material (typically 56 to 57 HRC).

#### Micro-cratering

Since frequency converters are more commonly used today, micro-cratering is by far the most common effect of electric current passage. The damage is characterized by molten pit marks. To the eye, this looks like a dull grey surface (→ fig 4). Multiple micro-craters cover the rolling element and raceway surfaces. Crater sizes are extremely small, mostly from 5 to 8 μm in diameter, irrespective of being found on the inner ring, the loaded zone of the outer ring or on a rolling element. The real shape of these craters can only be seen under a microscope using great magnification.

*A dull grey surface of the rolling elements can be a sign of micro-cratering*



## 6 Failure modes and corrective actions

### Electrical erosion/Inadequate lubrication

#### Fluting or washboarding

Fluting or “wash boarding” is seen as a pattern of multiple grey lines across the raceways (→ **fig 5**). The lines appear shiny and molten. The fluting results from a mechanical resonance vibration caused by the rolling elements when rolling over micro-craters.

Fluting is not considered to be a primary failure mode. Instead, it is considered to be secondary bearing damage – something that becomes visible over time.

#### Lubricant degradation

Local high temperatures cause the additives in the lubricant to char or burn the base oil. This causes the additives to be consumed more quickly, and makes the lubricant turn black and hard (→ **fig 6**).

This rapid breakdown drastically shortens grease life. If relubrication is not performed in time, secondary damage due to poor lubrication might result.

#### Corrective action

To prevent damage from electric current passage, an electrically insulated bearing at the non-drive end is usually used. There are two types of insulated bearings available from SKF: INSO-COAT bearings and hybrid bearings. More information about INSOCOAT and hybrid bearings can be found in **chapter 1** on **pages 25** and **27**.

## Inadequate lubrication

Inadequate lubrication will cause either surface distress or abrasive wear, thereby substantially reducing bearing service life. If the lubricant film between the rolling elements and raceways is too thin, due to inadequate viscosity or contamination, the surfaces will no longer be fully separated and there will be metal-to-metal contact.

#### Surface distress

There is a risk of surface distress for any bearing when the lubricant film is too thin. That risk is increased if there is sliding in the rolling contact. All rolling bearings show some sliding, also called micro slip, in the rolling contacts.

Surface distress is the consequence of asperities of rolling elements and raceways coming in direct contact.

When load and frictional forces rise to a given magnitude, small cracks form on the contact surfaces. These small cracks eventually develop into microspalls (→ **fig 7**).

When microspalls develop, the surface just looks dull and grey (→ **fig 8**), but under a microscope a number of cracks and spalls can be detected. Over time this damage can lead to flaking or the debris from microspalls can also lead to increased abrasive wear.

*Fluting or washboarding in a raceway caused by electrical erosion*



*Black discoloured grease caused by passage of current*



## 6 Failure modes and corrective actions

### Inadequate lubrication

*Surface distress:  
Micro spalling  
caused by metal-  
to-metal contact*

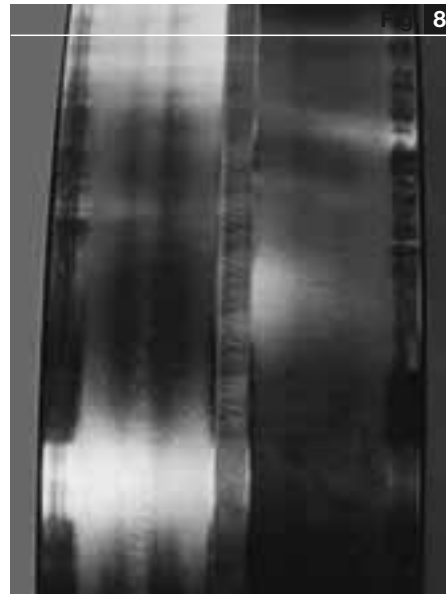
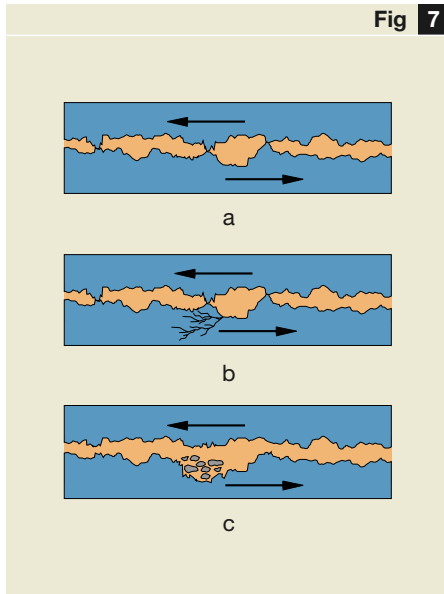

*Dull surface due  
to micro spalling*

#### **Abrasive wear**

Abrasive wear occurs between two mating surfaces sliding in relation to each other. The sliding motion wears the surfaces like sandpaper does. Abrasive wear is characterised by dull surfaces. Abrasive wear is a self-perpetuating process because the wear particles further reduce the lubricant's effectiveness which increases wear.

Sometimes, however, the wear particles act as a polishing agent to make the contact surfaces extremely shiny. The result of abrasive wear depends on the size of the particles and their hardness (→ fig 9).

#### **Corrective action**

Check first whether the proper lubricant is being used and that re-greasing intervals are adequate for the application. If the lubricant contains contaminants, check the seals to determine if they should be replaced or upgraded.

*Cylindrical roller  
with mirror-like  
surface due to  
polishing abrasive  
wear*



In some cases, depending on the application, a lubricant with a higher viscosity may be needed to increase the oil film.

## Bearing fatigue

Most bearings outlive the machines to which they are fitted. However, if the operating conditions are not optimal, or if the bearing loads are higher than the fatigue load limit, sooner or later material fatigue will occur. The period of time until the first sign of material fatigue appears is a function of

- the number of revolutions performed by the bearing,
- the magnitude of the load, and
- the operating temperature.

Material fatigue is the result of cyclically stressing the bearing material. This leads to a build-up of residual stresses that will cause structural changes immediately below the load carrying surface.

Over time, cracks develop in this subsurface area. When these cracks come to the surface, fragments of material start to flake off as the rolling elements pass over the cracks. This is known as subsurface fatigue. The flaking gets progressively worse until the bearing is unusable.

The service life of a bearing is defined as the number of revolutions the bearing performs until incipient flaking occurs.

Flaking will gradually extend, but this can happen over a relatively long period of time, depending on the application and its operating conditions. As the bearing's condition worsens, noise and vibration levels will increase. As a rule, there is usually enough time to prepare a replacement before the bearing fails catastrophically.

Subsurface fatigue was an important failure mode in the past. With the present improvements in bearing steel manufacture, however, it has been found that failures initiate from the surface rather than from cracks formed beneath the surface.

## Damage from vibration

Motors that are transported without the shaft and rotor held securely in place, can be subjected to vibrations within the bearing clearance that could damage the bearings.

Similarly, if a motor is at a standstill and subjected to external vibrations over a period of time, the bearings can also become damaged.

When a motor is at a standstill, there is no lubricant to form a film in the contact zones between the bearing components. The absence of this lubricant film allows metal-to-metal contact between the rolling elements and raceways. If external vibrations are introduced, the vibrations cause very small movements of the rolling elements relative to the rings. These movements cause a combination of corrosion and wear, forming depressions in the raceway. The depressions appear at rolling element distance and can often be discoloured or shiny. This damage is known as false brinelling (→ fig 10).

False brinelling occurs also in large machines with heavy rotors. Roller

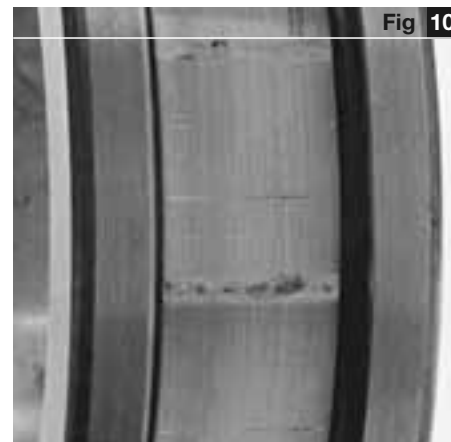

*False brinelling in a cylindrical roller bearing due to vibration at standstill*



*Motor secured for transport*

## 6 Failure modes and corrective actions

### Damage from vibration/ Damage caused by improper installation and set-up

bearings are more sensitive to this phenomenon as rollers can slide along the contact line with the raceways.

It takes some time for the initial damage to develop in size to such an extent that it will be discovered. Therefore, it can be difficult to trace the root cause of the failure to “transport” without a careful analysis of the damaged components.

#### Corrective action

False brinelling during transport can easily be avoided. Secure the bearings during transport in the following manner. First lock the shaft axially using a flat steel bent in a U-shape, while carefully preloading the ball bearing at the non-drive end. Then radially load the bearing at the drive end with a strap (→ **fig 11**). By doing so, the rolling elements are locked in position and no relative movement can occur. Vibration damage is avoided.

In case of prolonged periods of standstill, turn the motor regularly (→ **chapter 2** “Bearing arrangements – Preloading with springs” on **page 47**).

## Damage caused by improper installation and set-up

Electric motors are an important component of any machine. Without them, most machines would be out of service. Therefore, we have all come to rely on electric motors to operate effectively and to provide trouble free operation.

However, unless a motor is installed and set-up properly, it will not realize its expected service life even if it is made from high quality components.

The following are some examples of typical installation and set-up errors that can significantly reduce motor life – especially as they relate to the bearings.

#### Mounting components on the drive end of the shaft

Using a hammer or other similar tool to mount a coupling half or belt pulley onto a shaft can significantly reduce bearing life. When the component is struck, the force from the blow is transferred from the inner ring to the outer ring through the rolling elements. This axial shock load will cause indentations in the bearing raceways to dramatically reduce bearing service life.

#### Corrective action

Press the component onto the shaft with the appropriate tool. Make use of the shaft thread or heat the component before mounting.

#### Poor alignment

If the shaft of an electric motor is not aligned carefully with the shaft of the driven component, the bearings in both applications will be subjected to additional forces. These additional forces could be substantial enough to significantly reduce the service life of the bearings of both the motor and driven unit.

#### Corrective action

Use a precision instrument like the SKF Shaft Alignment Tool (→ **fig 12**), to be sure that the shafts of both the drive and the driven units are aligned correctly. If after using a precision instrument the shafts are still not aligned, check for “soft foot”.

Use a shaft alignment tool



Fig 12

## 6 Failure modes and corrective actions

### Damage cause by improper installation and set-up

SKF Microlog  
for vibration  
measurements



Fig 13

#### Unbalance

Substantial unbalance in the driven unit can be transferred to the motor. These vibrations will shorten bearing service life.

#### Corrective action

Check the vibration level of the driven unit looking for the root cause of the problem (→ fig 13). For a fan, for instance, check the fan blades and clean them if necessary. If the vibration level is still too high, re-balance the impeller.

#### Excessive belt tension

Excessive belt tension is a common cause of premature bearing failure. In most cases, the excessive loads from the belt cause unnecessarily high loads on the motor bearings to significantly reduce the service life of the bearings and the belt.

Higher loads also mean higher operating temperatures, which will reduce the effectiveness of the lubricant and consequently the bearing service life.

Excessive belt tension can also cause movements of the inner ring relative to the shaft to cause fretting corrosion.

#### Corrective action

Check that the belts have the correct tension. Simple tools for measuring belt tension are available on the market.

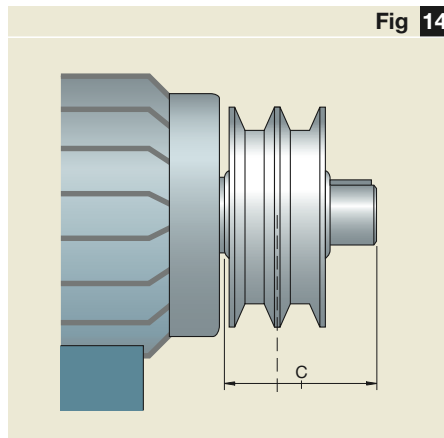

Fig 14

Where to place  
the pulley

#### Excessive shaft deflection

If the bending torque on a shaft is excessive, the shaft deflection will give rise to additional bearing forces, leading to shorter bearing service life. Mounting a belt pulley at the very end of a shaft will create high bending torque and consequently higher bearing loads.

Excessive shaft deflection might also lead to fretting corrosion or creep of the bearing inner ring.

#### Corrective action

Mount the belt pulley as close as possible to the drive end bearing. The centre of the pulley must not be mounted outside the middle of the shaft end (dimension C → fig 14).

## 6 Failure modes and corrective actions

### Insufficient bearing load/Other damage

#### Insufficient bearing load

When a motor runs without a load, there is an immense risk that the bearings will become damaged, since they always need to have a minimum load to function well. The damage will appear as smearing on the rolling elements and raceways.

It takes time for the initial damage to develop to such an extent that the bearing damage can be detected.

#### Corrective action

Make sure to apply an external load to the bearings. It is most important to remember this when using cylindrical roller bearings, since they are typically used to accommodate heavier loads.

This does not apply to preloaded bearings (→ section “Preloading with springs” on **page 47**).

#### Other damage

#### Overload from mounting errors

Incorrect mounting methods can significantly reduce bearing service life. Damage caused by incorrect mounting frequently appears as equally spaced indentations where the rolling elements were pushed into the raceways. Over time, flaking is likely to start from these indentations (→ **fig 15**).

These indentations are usually formed when the mounting force is applied to the wrong bearing ring and the force is transmitted through the rolling elements; or when a hammer or similar tool is used to mount a component, such as a shaft pulley, sprocket or coupling.

Cylindrical roller bearings must be assembled very carefully in order not to damage the bearing. Often times the two rings are not properly aligned during the assembly process and the rollers scratch the other raceway causing long transverse streaks (→ **fig 16**).

#### Corrective action

Use appropriate mounting tools and methods. In the case of cylindrical roller bearings the use of a guiding sleeve is strongly recommended (→ **chapter 5** “Mounting and dismounting – Mounting of separable bearings” on **page 82**).

*Mounting error:  
Flaking will start  
from the indentations at rolling  
element distance*



Fig 15

*Transverse smear  
streaks from faulty  
assembly*



Fig 16

## 6 Failure modes and corrective actions

### Other damage

#### Damage due to indentations from contamination

Contaminants can be introduced into the bearing cavity from a variety of sources. The most common sources of contamination originate from

- the work surface or the work area, such as casting sand and other dirt that was not washed from the housing, or
- contaminants contained in the lubricant, or
- damaged or inefficient sealing, or
- damaged shaft surfaces, or
- inadequate relubrication practice, if applicable.

These particles, when over rolled by the rolling elements, create indentations in the raceways (→ fig 17) that may cause fatigue and eventually cause spalling.

#### Corrective action

- Do not unpack the bearing until immediately before mounting.
- Keep the workshop and tools clean.
- Use clean lubricant.
- Make sure the grease nipple is clean when relubricating.
- Make sure seals and counterfaces are in good condition.

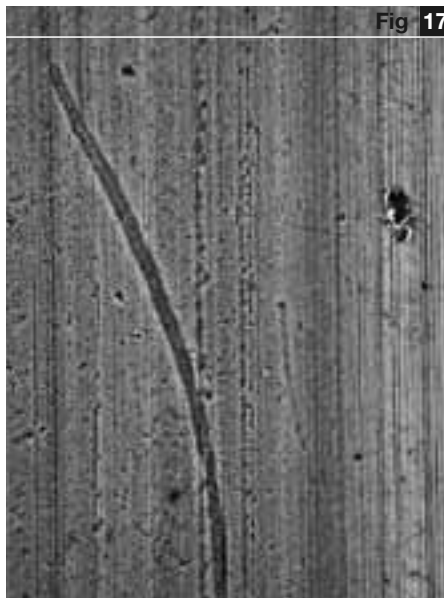

*Indentations in the raceway caused by over-rolled contaminants*



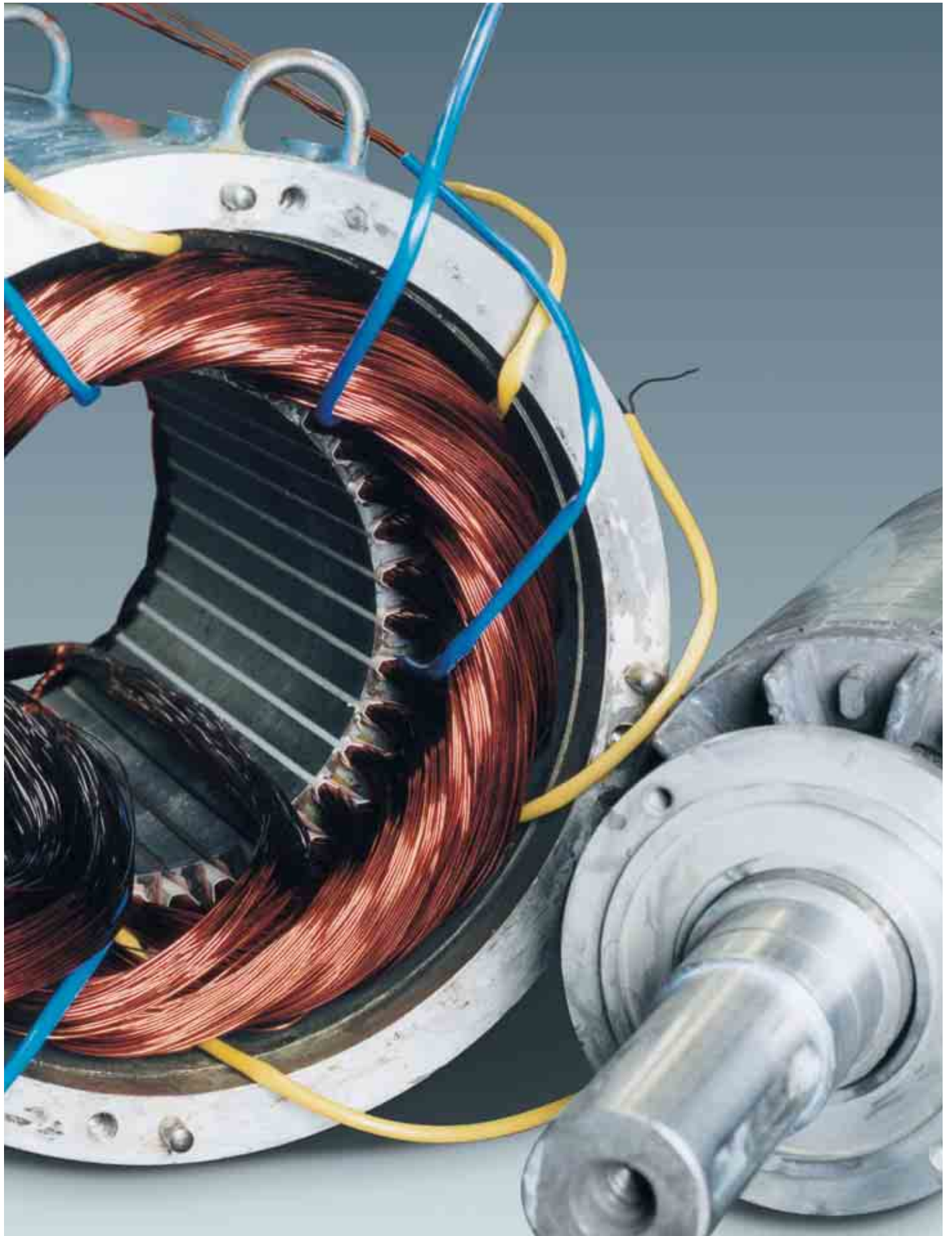

**7 SKF solutions**

**SKF Engineering  
Consultancy Services ... 104**

**SKF calculation tools ... 105**

**Application specific  
solutions ..... 107**

**Condition monitoring ... 111**



# SKF solutions

SKF has applied its extensive knowledge of industrial applications to develop system solutions that yield cost-effective results.

These solutions, some of which do not even incorporate bearings, underscore SKF's continuing effort to apply its core competencies in the areas of the future: mechatronics and electronics.

In this chapter, some of the solutions are presented that could be offered to meet the real conditions for typical electric motor and generator applications.

## SKF Engineering Consultancy Services

Over the last century SKF has gathered expert knowledge in rotating machinery. As a part of SKF's strategy of strengthening the position as a service providing partner, this know-how is now made available to customers on a commercial basis, even when the challenge lies outside the bearing. This is done via the SKF Engineering Consultancy Services (ECS), a business unit within SKF.

With a team of dedicated experts in rotating machinery and specialized tools ECS provides a powerful complement to customer's experts in their own industry. Being an SKF business unit ECS is part of a global engineering network with extensive resources.

### ECS services

#### Design optimization

By means of computer simulation of entire systems and lubrication optimization ECS helps customers meet their objectives. In some cases, customers want to improve the cost-effectiveness of their equipment. In other cases, customers want to increase the performance of their equipment. In either case, the earlier the ECS team can get involved, the greater impact they can make.

#### Design verification

Your ECS team can use specially developed computer programs to simulate system behaviour and verify that a new design will perform to expected levels. And though it may seem like a time consuming process, crashing the ECS virtual test rig is far less expensive than crashing a real one.

The real benefits, however, can be seen in the "time-to-market" calculation. Using SKF's simulation tools, you will be able to reduce your development and testing time substantially.

#### Trouble shooting

If there's a problem on the test rig or in the field, let the SKF Engineering Consultancy Service help. With our team of experts we will be able to help you do any of the following:

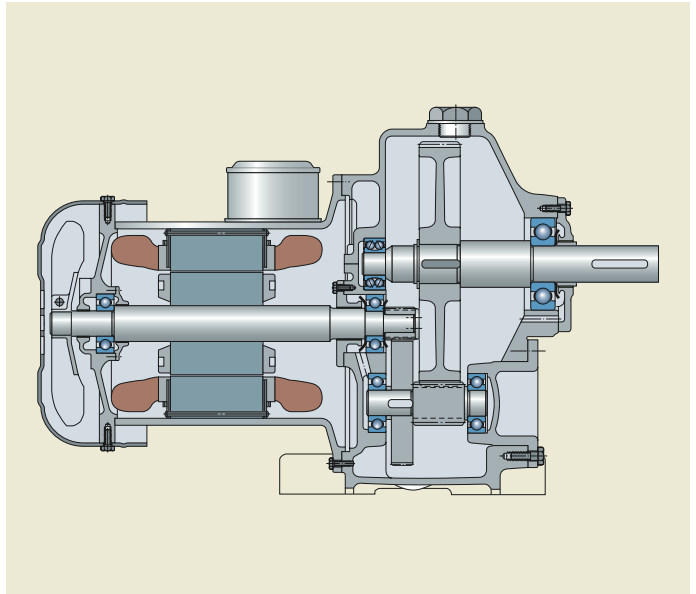

- Analyze and recommend remedies for electrical erosion that consider the whole system including the frequency converter, auxiliary equipment and more.
- Lower noise and vibration levels and improve running accuracy by optimizing the bearing arrangement, related components and any other systems that may be contributing to the phenomenon.
- Increase power density by decreasing the overall size of the system.
- Conduct root cause failure analysis by combining bearing failure analysis with computer simulation.
- Optimize lubrication.
- Reduce manufacturing costs by optimizing manufacturing tolerances.

Some of the tools used by the SKF Engineering Consultancy Services are described briefly in the section "SKF calculation tools."

For additional information regarding the activities of the SKF Engineering Consultancy Services please contact your local SKF representative.

## SKF calculation tools

SKF possesses one of the most comprehensive and powerful sets of modelling and simulation packages in the bearing industry. They range from easy-to-use tools based on the SKF General Catalogue formulae to the most sophisticated calculation and simulation systems, running on parallel computers.

The company's philosophy is to develop a range of programs to satisfy a number of customer requirements; from fairly simple design checks, through moderately complex investigations, to the most advanced simulations for bearing and machine design. Wherever possible these programs are available for use on customers' or SKF engineers' laptops, desktop PCs or workstations. Moreover, particular care is taken to provide integration and interoperability of the different systems.

### SKF Interactive Engineering Catalogue

The SKF Interactive Engineering Catalogue (IEC) is an easy-to-use tool for bearing selection and calculation. Bearing searches are available based on designation or dimensions, and simple bearing arrangements can be evaluated as well. The equations used are in line with the theories of the SKF General Catalogue.

It also allows the generation of CAD bearing drawings that can be imported into customer application drawings developed with the major CAD commercial packages.

The SKF Interactive Engineering Catalogue also contains in addition to the complete range of rolling bearings, catalogues covering bearing units, bearing housings, plain bearings and seals.

The SKF Interactive Engineering Catalogue is published on CD-ROM or online at [www.skf.com](http://www.skf.com).

### SKF Toolbox

The SKF Toolbox is a set of engineering calculation programs accessible through the SKF website, [www.skf.com](http://www.skf.com). It contains several calculation tools and uses theory from the General Cata-



logue and some basic mechanical engineering equations. For instance, it can calculate bearing clearance reduction due to interference fit and operating temperature, contamination factors or data for mounting of specific bearing arrangements.

### Ginger

Ginger is the new mainstream bearing application program used by SKF engineers to find the best solution for customers' bearing arrangements. Its technology allows the modelling in a 3D graphic environment of flexible systems incorporating customer components for both static and dynamic simulations. Ginger combines the ability to model generic mechanical systems (using also shafts, gears, housings etc.) with a precise bearing model for an in-depth analysis of the system behaviour in a virtual environment. It also performs bearing rolling fatigue evaluation using the SKF rating life. Ginger is derived from the research and development tool Orpheus (see next paragraph) and as such is the result of several years of specific research and development within SKF.

### Orpheus

The numerical tool Orpheus enables engineers to study and optimize the dynamic behaviour of noise and vibration in critical bearing applications (e.g. electric motors, gearboxes). It can be used to solve the complete

## 7 SKF solutions

### SKF calculation tools

non-linear equations of motion of a set of bearings and their surrounding components, including gears, shafts and housings.

It can provide profound understanding of and advice on the dynamic behaviour of an application, including bearings, accounting for form deviations (waviness) and mounting errors (misalignment). This enables SKF engineers to determine the most suitable bearing type and size as well as the corresponding mounting and pre-load conditions for a given application.

#### **Beast**

Beast is a simulation program that allows SKF engineers to simulate the detailed dynamics inside a bearing. It can be seen as a virtual test rig performing detailed studies of forces, moments etc. inside a bearing under virtually any load condition. This enables the “testing” of new concepts and designs in a shorter time and with more information gained compared with traditional physical testing.

#### **Other programs**

In addition to the above-mentioned programs, SKF has developed dedicated computer programs that enable SKF scientists to provide customers with bearings having an optimized bearing surface finish to extend bearing life under severe operating conditions. These programs can calculate the lubricant film thickness in elasto-hydrodynamically lubricated contacts. In addition, the local film thickness resulting from the deformation of the three dimensional surface topography inside such contacts is calculated in detail and the consequent reduction of bearing fatigue life.

In order to complete the necessary capabilities for their tasks, SKF engineers use commercial packages to perform e.g. finite element or generic system dynamics analyses. These tools are integrated with the SKF proprietary systems allowing a faster and more robust connection with customer data and models.

## Application specific solutions

### Induction motors equipped with frequency convertors

Since the 1990's the use of pulse width modulated (PWM) frequency convertors has increased. An increase of premature bearing failures caused by electrical erosion or arcing, has been observed (→ **chapter 6** "Failure modes and corrective actions", starting on **page 91**). These types of failures typically cause machine shutdowns that decrease production while significantly increasing maintenance costs and/or warranty costs.

To better understand electrical erosion and its effect on bearing and machine service life, SKF has an ongoing program to study the problem and develop cost-effective solutions.

#### A solution to electrical erosion

A key to solving the problem of electrical erosion is to insulate the shaft from the housing so that stray currents do not "seek ground" through the bearings. Though there is no one best way to do this, some solutions, like special shaft coatings or insulated end shields, can be more expensive than others.

*INSOCOAT is applied to either the outer ring or inner ring of a bearing*

One very cost effective way to solve the problem is to insulate the bearing. One can apply a ceramic coating to one of the rings (INSOCOAT), or use ceramic rolling elements and create a hybrid bearing (→ **chapter 1, pages 25 and 27**). Either of these solutions will provide two functions, by acting as a bearing and an insulator (→ **figs 1 and 2**).

In applications where electrical erosion is caused by circulating currents, a single "insulated bearing" on the non-drive end will be sufficient to break the current path inside the motor. For additional information contact your local SKF representative.

SKF's insulated bearings have standard boundary dimensions according to ISO 15:1998. They should be handled with the same care as standard bearings.

*Hybrid deep groove ball bearing*



Fig 1



Fig 2

### Electric behaviour of insulated bearings

To better understand how insulated bearings work, one must first distinguish between DC current and AC current applications.

In DC applications, INSOCOAT acts as a pure 50 M $\Omega$  resistor. Therefore, it can accommodate voltages in excess of 1 000 VDC before there is a breakdown and an electric arc. For the ceramic rolling elements in a hybrid bearing, those values are even higher.

In AC applications, especially in variable speed drives, (VSDs) one has to consider the impedance of the insulating material. The impedance describes the voltage-current relationship in an AC circuit.

The value of the impedance depends mainly on two electrical factors: the capacitance and the frequency. The capacitance should be as small as possible and is dependent on bearing size.

### Motor control in three-phase drives

Changing from direct current drives to three-phase drives offers many advantages. The three-phase induction motor is the most commonly used type of motor in industrial applications, offering a robust and virtually maintenance-free solution. However, in order

to control speed and direction of rotation, it is necessary to use an additional electronic device that records the motor speed. In most cases, a resolver or an optical encoder is mounted on the induction motor to perform this function.

### SKF Sensor-Bearing Units

SKF Sensor-Bearing Units ( $\rightarrow$  fig 3) are mechatronic machine components that combine sensor and bearing technology. These units, use a sensor that is shielded from external influences. The sensor body, impulse ring and bearing are mechanically attached to each other, forming an integrated ready-to-mount unit.

SKF designed and patented Sensor-Bearing Units are simple and robust.

SKF Sensor-Bearing Units are specially designed to perform as incremental encoders for motor and/or machine control. They are specially adapted to fit asynchronous motors, and provide compact and reliable encoding for their most demanding control ( $\rightarrow$  fig 4). They are intended for applications with a rotating inner ring and stationary outer ring.

*The SKF sensor bearing unit occupies no extra radial space, is well protected inside the motor and provides a reliable steady signal*

SKF Sensor-Bearing Unit



Fig 3

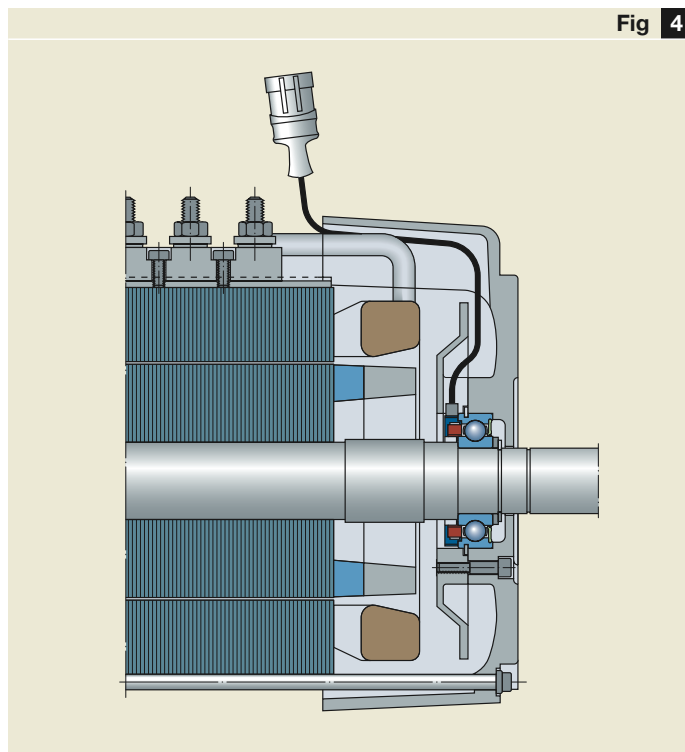

Fig 4



## Large and very large electric machines

Today, the most common bearing solution in large and very large electric motors and generators consists of a sleeve bearing unit. This unit includes a sleeve bearing, a housing and other components such as electrical insulation, and an air pressure chamber for flanged units.

The sleeve bearing unit is considered to be costly, especially under certain conditions.

In applications with very low speeds, changes in the direction of rotation (reversing) or combined radial and axial loads, the oil film thickness can drop to almost zero. This inadequate lubrication condition can cause metal-to-metal contact, which can damage the sleeve bearing and cause premature failure. To avoid this condition, additional equipment is needed so that extra oil pressure can be supplied to the bearing.

To maximize the service life of a sleeve bearing, the lubricating oil must do two things:

- provide a sufficient oil film between the shaft and bearing, and
- dissipate heat from the bearing to keep it running cool.

*A flanged housing unit with a CARB toroidal roller bearing*

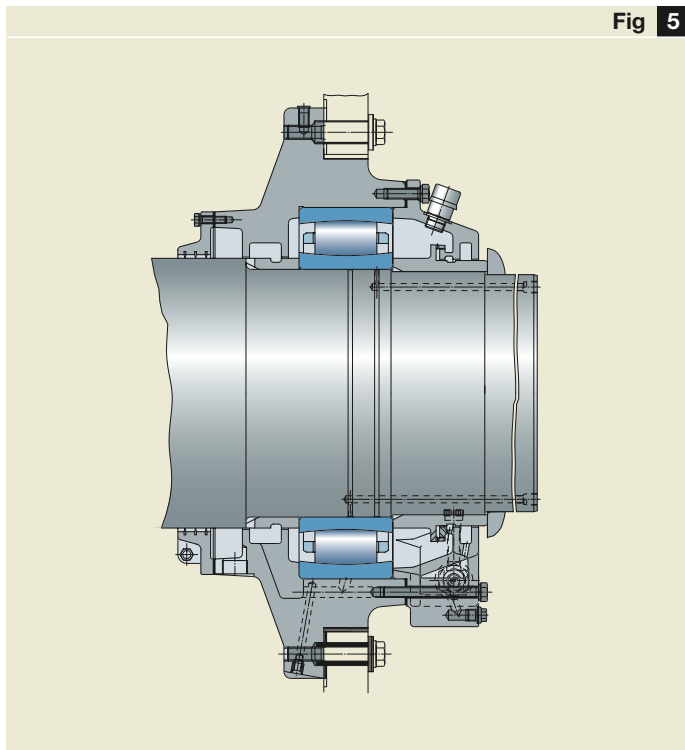

High operating temperature means low oil operating viscosity. The viscosity might be insufficient to form a protective oil film. Therefore sleeve bearing units need special oil circulation systems that include coolers.

To replace these sleeve bearing units, SKF offers flanged housing units that contain rolling bearings.

### SKF flanged housing units with rolling bearings

To counteract the high cost of a sleeve bearing system, SKF developed a shaft system that consists of two flanged housings; each equipped with a roller bearing. For this system, a spherical roller bearing is used as the locating bearing. The non-locating bearing can be either a CARB toroidal bearing (→ fig 5) or another spherical roller bearing. The advantage of the CARB bearing is that it accommodates axial displacement like a cylindrical roller bearing and misalignment like a spherical roller bearing. This is particularly important in applications where thermal expansion of the shaft is a key operating parameter.

The SKF shaft system copes with reverse directions, axial loads, accommodates thermal expansion of the shaft and deflections, and operates at slow speeds without extra components like thrust bearings or hydrostatic jacking devices. This can be particularly important for motors used in steel mills and marine propulsion units.

Designed for oil bath lubrication, the SKF shaft system does not need expensive oil circulation systems, which eliminates the need for pumps, pipes, oil sumps and coolers. Specially designed labyrinth seals are used to keep the lubricant in and contaminants out.

From a maintenance standpoint, regular oil changes are all that are necessary.

When compared to a sleeve bearing unit, the SKF shaft system is a cost effective solution that is simpler, has fewer components, and is easier to maintain. Moreover, auxiliary systems such as hydrostatic jacking systems or thrust pads to accommodate axial loads are not required. Variants using an oil reservoir with a clever oil level monitoring device, adjusting and re-

## 7 SKF solutions

### Application specific solutions

#### An SKF ICOS unit

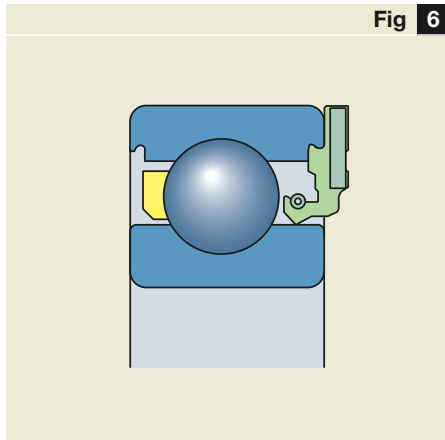

Fig 6

plenishing the oil level during operation can also be offered.

For further details, please consult the SKF application engineering service.

### Gearmotors

Sealing is important as cleanliness has a direct impact on environment and performance.

In modern gearmotors are usually the motor bearings grease lubricated and the gearbox oil lubricated.

In the motor, bearing seals are integrated into the bearing design and are intended for use with grease. In the gearbox, oil seals are typically used to keep the lubricating oil inside and to protect gears and bearings from external contaminants. These external seals require

- additional engineering,
- additional space,
- fine machining (and eventually hardening),
- additional logistics,
- additional inventory,
- special handling.

All of this yields greater efforts and higher costs.

### SKF ICOS™ units

To simplify the sealing process and reduce costs, CR Seals, a division of SKF developed the Integrated Compact Oil Seal unit. This unit integrates a unique spring loaded radial shaft seal into a bearing (→ fig 6).

The unit, which can be used in either grease or oil lubricated applications without additional seals, requires less space than the typical two-component arrangement. The ICOS unit simplifies mounting and avoids expensive machining of the shaft because the inner ring shoulder serves as a perfect seal counterface.

ICOS units can also provide benefits in applications

- with heavy contaminated, environment,
- with presence of water flow,
- incorporating brush motors,
- where grease leakage cannot be tolerated.

## Condition monitoring

The aim of using a condition monitoring system is to measure the condition of “wear” components and other functions that influence machine reliability. The advantage of condition monitoring using vibration analysis is that it acts as an early warning system. Consequently, this means that there is sufficient time for corrective actions and bearing replacement can be well planned (→ **diagram 1**).

Examples of components and systems that can be monitored are:

- bearings
- belt drives
- gearboxes
- electric motors

Some components, such as seals, can not be monitored, but need manual inspection.

### Multi-parameter monitoring

Jointly developed by SKF Condition Monitoring and the SKF Engineering and Research Centre in the Netherlands, multi-parameter monitoring is the most comprehensive, reliable and accurate approach to machinery monitoring and analysis. Collecting and analysing multiple measurement parameters greatly increases the capability to accurately and readily identify bearing damage and other machinery problems.



Vibration Pen<sup>plus</sup>

By measuring a number of machinery related parameters such as acceleration, velocity and displacement and process parameters such as speed, temperature, current, pressure and flow, users gain insight into a specific machine’s condition. Advanced analysis techniques such as Acceleration Enveloping enable analysts to take the guesswork out of maintenance by supplying the required information needed in order to take the necessary measures preventing unscheduled downtime.

### Vibration

Traditional low frequency vibration monitoring remains essential in identifying problematic machinery conditions. Generally, malfunctions that cause vibration and loss of machine efficiency ultimately result in damage to the machine or its components. While low frequency vibration analysis can be an effective indicator of bearing damage, it may not be the most timely.

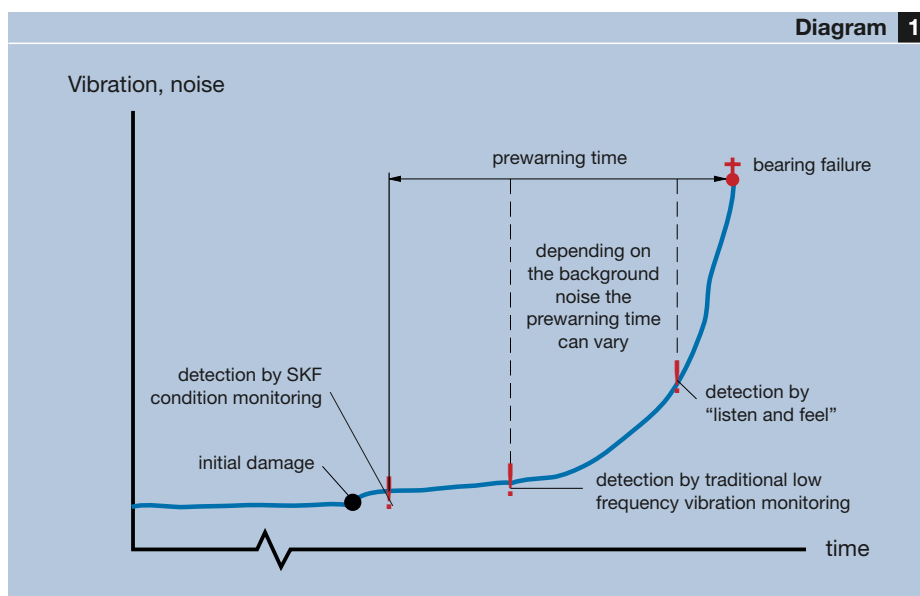

**The advantage of condition monitoring**

### Acceleration enveloping

For early detection of machine damage, enveloping techniques are very effective. Enveloping enhances repetitive signals caused by the pulses emanating from a damaged bearing, for example. In the early stages, bearing damage generates a signal that may go undetected amid general machine vibration “noise”. The use of envelope detection makes it possible to pinpoint not only the nature, but the location of the bearing or gear damage.

### Operator tools

Economical, easy-to-use, handheld instruments provide a quick and basic indication of problem areas.

The Vibration Pen<sup>plus</sup> is a pocket-sized, go anywhere measurement device which measures overall vibration levels according to ISO standards and acceleration enveloping peak values according to SKF standards.

The hand-held product range also features the MARLIN<sup>®</sup> condition detector, which is a hand-held probe that collects and compares operating data to provide advance warning of costly machine problems.

The handheld instrument range provides operators with the means to become key participants in providing greater machine reliability. With the press of a button, operators detect significant changes in machine operation that could require further investigation.

### Portable data collection

Portable data collectors such as the MICROLOG<sup>®</sup> allow efficient data collection and on-site analysis. The models CMXA50 and CMVA60 are unique. Embedded intelligence provides step-by-step instructions for performing critical analysis functions. Data collected by the MICROLOG<sup>®</sup> may be up-loaded to SKF Machine Analyst<sup>™</sup>, Windows Data Management and Analysis Software, for further analysis and trending.

### Continuous monitoring

On-line monitoring for round-the-clock bearing and machinery analysis offers significant advantages. With the Multi-log Local Monitoring Unit, permanently installed sensors collect data from

hard-to-reach or problematic machine sections. Those sensors eliminate the need for manual or walk-around data collection, while Machine Analyst<sup>™</sup> On-Line displays up-to-date information on machine operation for powerful “real-time” analysis. Such systems offer the greatest degree of worker safety and data consistency.



MARLIN<sup>®</sup>



MICROLOG<sup>®</sup>  
CMXA50

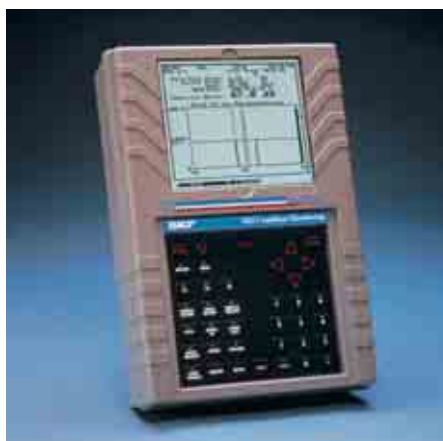

MICROLOG<sup>®</sup>  
CMVA60

## 7 SKF solutions

### Condition monitoring

#### SKF Machine Analyst™

SKF Machine Analyst™ is a software platform, using an Oracle relational database, which provides a comprehensive reliability solution for manufacturing plants. It gives the user complete control over condition monitoring data, as well as analysis and reporting, with extensive customized features. Toolbars, data plots, security levels, screen layout and more can all be changed to suit individual users.

Written from the ground up using Component Object Model (COM) architecture, SKF Machine Analyst™ can be easily and effectively integrated with third party plug-ins, as well as systems such as Computerized Maintenance Management Systems, Enterprise Resource Planning and others.

The software also offers a number of time saving features. It allows a user to automatically schedule key operations such as reporting or archiving at specific times or after an action occurs, such as uploading data. An Alarm Wizard automatically calculates a reliable set of alarm criteria, setting appropriate parameters for vibration levels tailored to the specific plant.

#### SKF Maintenance Products

In an era of increased downsizing of the fixed work force and increased pressures to produce more in less time, SKF focuses on providing customers with the tools and services they need to remain competitive.

The vast range of SKF maintenance products provides simple, flexible and reliable solutions to its customers' maintenance needs. Whether the customer is looking for the latest hydraulic jaw puller or simply a pair of heat resistant gloves, SKF has the product that matches the requirements.

For more information or a detailed product catalogue, please contact your local SKF representative or visit SKF Maintenance Products online at [www.mapro.skf.com](http://www.mapro.skf.com)



