

Quick-ship – Easy Serve Program from SKF®

Profile rail guides



SKF profile rail guide interchangeable series

- 2-3 day turn around for up to two rails and four carriages on any specified length*
- No set-up fee
- Two regional cut centers to choose from
- Complete range of SKF standard carriages in stock at both locations
- Ask your SKF representative about flexible stocking program for specific customer needs

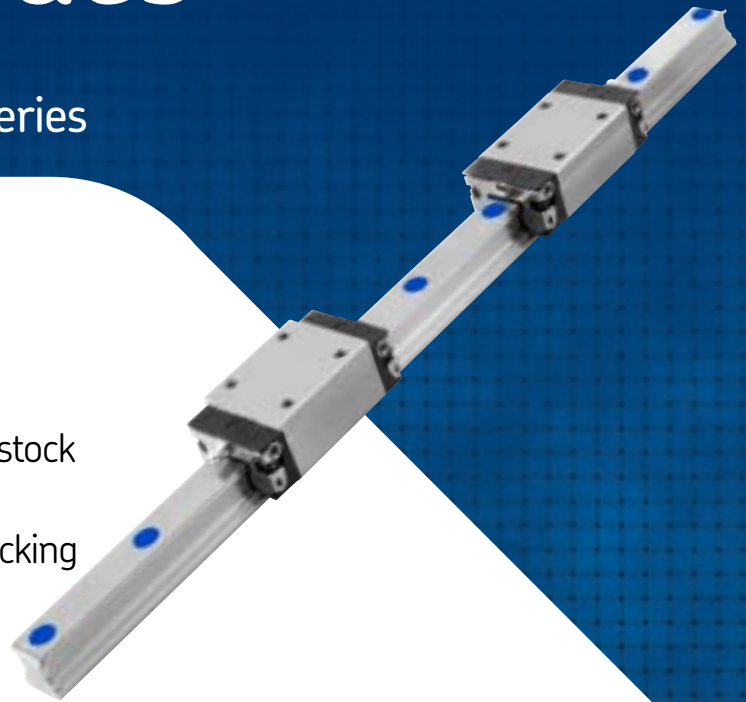

Commonly stocked lengths

| LLRHR 15 | LLRHR 20 | LLRHR 25 | LLRHR 30 | LLRHR 35 | LLRHR 45 |
|----------------|----------------|----------------|----------------|----------------|----------------|
| LLRHR15x220P5 | LLRHR20x220P5 | LLRHR25x220P5 | LLRHR30x280P5 | LLRHR35x280P5 | LLRHR45x570P5 |
| LLRHR15x280P5 | LLRHR20x280P5 | LLRHR25x280P5 | LLRHR30x440P5 | LLRHR35x440P5 | LLRHR45x885P5 |
| LLRHR15x460P5 | LLRHR20x340P5 | LLRHR25x340P5 | LLRHR30x600P5 | LLRHR35x600P5 | LLRHR45x1200P5 |
| LLRHR15x820P5 | LLRHR20x460P5 | LLRHR25x460P5 | LLRHR30x760P5 | LLRHR35x760P5 | LLRHR45x2040P5 |
| LLRHR15x1500P5 | LLRHR20x820P5 | LLRHR25x640P5 | LLRHR30x1000P5 | LLRHR35x1000P5 | |
| | LLRHR20x1000P5 | LLRHR25x820P5 | LLRHR30x1240P5 | LLRHR35x1240P5 | |
| | LLRHR20x1240P5 | LLRHR25x1000P5 | | LLRHR35x1640P5 | |
| | | LLRHR25x1240P5 | | LLRHR35x2040P5 | |
| | | LLRHR25x1600P5 | | | |

Toll free 1-800-541-3624
Fax 610-861-3737

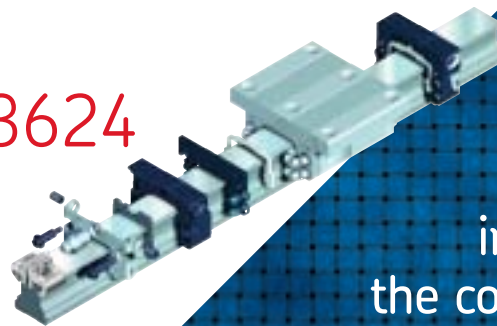

For more information on the complete line of products, contact your SKF Representative, call us at 800-541-3624 or visit us at www.linearmotion.skf.com

Add one day for truck shipment (Weight or length restrictions may apply)

*Valid for rail cut to length, attached rail available upon request

Corrosion resistant rails and carriages available upon request

Easy Serve delivery program available for precision ground shaft

Complete ball screw and spindle rebuilding capabilities

Interchange

| SKF | THK | Thomson | | NSK |
|--|---|--|---|--|
| | | old | new | |
| Carriage part number <u>LLRHC 20 A-T1</u> 1 2 3 7 | Carriage part number <u>HSR 20 A SS</u> 1 2 3 8 | Carriage part number <u>CG 20 AA</u> 1 2 3 | Carriage part number <u>511 H 20 A 1</u> 1 6 2 3 7 | Carriage part number <u>LAH 20 EL</u> 1 2 3 |
| Rail part number <u>LLRHR 20 x XXXX P3</u> 1 2 4 6 | Rail part number <u>HSR 20 + XXXXL H</u> 1 2 4 6 | Rail part number <u>RG 20 H LXXXX</u> 1 2 6 4 | Rail part number <u>521 H 20 AXXXX</u> 1 6 2 | Rail part number <u>L1H 20 XXXX</u> 1 2 4 |
| Assembly part number <u>LLRHS 20 A 2 T1-XXXX P3</u> 1 2 3 5 7 4 6 | Assembly part number <u>HRS 20 A 2 SS C1+XXXXL H</u> 1 2 3 5 8 7 4 6 | Assembly part number N/A | Assembly part number N/A | Assembly part number <u>LH 20 XXXX EL 2 P6 ZT</u> 1 2 4 3 5 6 7 |

| Linear guide series - 1 | | | | |
|-------------------------|-----------|---------|-----|----------|
| SKF | THK | THOMSON | | NSK |
| | | old | new | |
| LLRHS LLRHS | HSR SR | CG | 511 | LH LS |

| Rail length - 4 | |
|-----------------|-----------------------------|
| SKF: | LLRHR ## x XXXX P5 |
| THK: | HSR ## + XXXXL |
| THOMSON: | RG ## NLXXXX or 521H##AXXXX |
| NSK: | L1H##XXXX |
| SKF: | LLRHR ## x XXXX P5 |
| THK: | SR ## + XXXXL |
| NSK: | L1S##XXXX |
| THOMSON: | 521H##AXXXX |

| Linear guide size - 2 | | | | |
|-----------------------|--------|---------|--------|-------|
| SKF | THK | THOMSON | | NSK |
| | | old | new | |
| LLRHS 15 | HSR 15 | | 511 15 | |
| LLRHS 20 | HSR 20 | CG 20 | 511 20 | LH 20 |
| LLRHS 25 | HSR 25 | CG 25 | 511 25 | LH 25 |
| LLRHS 30 | HSR 30 | CG 30 | 511 30 | LH 30 |
| LLRHS 35 | HSR 35 | CG 35 | 511 35 | LH 35 |
| LLRHS 45 | HSR 45 | CG 45 | 511 45 | LH 45 |
| LLRHS 15 | SR 15 | | | LS 15 |
| LLRHS 20* | SR 20 | | | LS 20 |
| LLRHS 25* | SR 25 | | | LS 25 |
| LLRHS 30 | SR 30 | | | LS 30 |
| LLRHS 35 | SR 35 | | | LS 35 |
| LLRHS 45 | SR 45 | | | |

| Carriages per rail - 5 | |
|--|--|
| Number following carriage style = number of carriages per rail | |

| Accuracy class - 6 | | | |
|--------------------|-----|---------|-----|
| SKF | THK | THOMSON | NSK |
| P5 | | N | PC |
| P3 | H | H | P6 |
| P1 | P | P | P5 |
| P01 | SP | S | P4 |
| P001 | UP | U | P3 |

*Contact SKF for dimensional differences
SKF can also offer an equivalent to the SSR and SHS series from THK.

| Preload - 7 | | | |
|-------------|-----|------------|-----|
| SKF | THK | THOMSON | NSK |
| | | 511 series | |
| T0 | | A | 0 |
| T1 | C1 | B | 1 |
| T2 | C0 | C | 2 |
| T3 | | | 3 |
| | | | Z4 |

| Linear guide carriage styles - 3 | | | | |
|----------------------------------|------------------|-----------|---------|-----------|
| LLRHS series | | | | |
| SKF | THK | THOMSON | | NSK |
| | | old | new | |
| LLRHC ## A | HSR ## TA/CA/A | CG ## AA | 511 A | LAH ## EL |
| LLRHC ## A | HSR ## TB/CB/B | CG ## AA | 511 A | LAH ## FL |
| LLRHC ## LA | HSR ## LA/HA/HTA | CG ## BA | 511 B | LAH ## GL |
| LLRHC ## LA | HSR ## LB/HB/HTB | CG ## BA | 511 B | LAH ## HL |
| LLRHC ## R | HSR ## R/TR/CR | CG ## CE | 511 E** | LAH ## AN |
| LLRHSC ## LR | HSR ## LR/HTR/HR | CG ## DE* | 511 F** | LAH ## BN |

*check dimensions. ** contact SKF for size 20.

| Seals - 8 | |
|------------|---|
| SKF | Standard with side and bottom seals. |
| THK | SS - end/bottom seals UU - end seals |
| NSK | Standard with side and bottom seals. |

| Compact series | | | |
|----------------|---------|---------|-----------|
| SKF | THK | THOMSON | NSK |
| LLRHC ## U | SR ## W | 511 C | LAS ## AL |
| LLRHC ## SU | SR ## V | | LAS ## CL |
| LLRHC ## LU | | 511 D | |

| Lubrication systems | |
|---------------------|---|
| SKF | Internal foam insert standard in every carriage. Optional external reservoir also available upon request. |
| THK | QZ lubrication system is external to the carriage. |
| THOMSON | LL lubrication system is external to the carriage. |
| NSK | K1 lubrication system is external to the carriage. |

* FOR FULL DETAILS, PLEASE SEE SKF CATALOG #5350E.

© SKF is a registered trademark of SKF USA Inc.
 Although care has been taken to assure the accuracy of the data compiled in this publication, SKF does not assume liability for errors or omissions.
 © 2003 SKF USA Inc. Publication 980-419 (5/MAN 4/2006) Printed in USA

