

Linear Bushings and Shafts

The Drive & Control Company

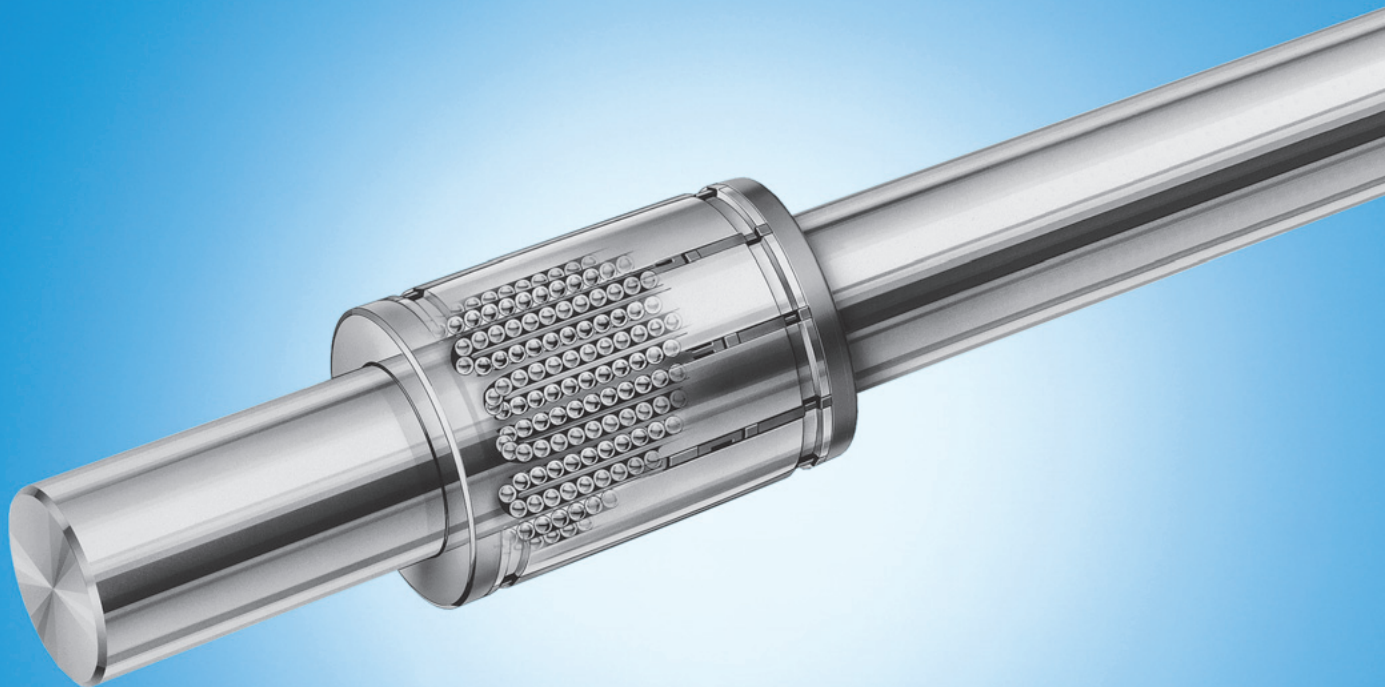

Linear Motion Technology

Ball Rail Systems

Standard Ball Rail Systems
 Super Ball Rail Systems
 Ball Rail Systems with Aluminium Runner Blocks
 Super Ball Rail Systems
 Corrosion-resistant Ball Rail Systems
 Wide Ball Rail Systems

Ball Rail Systems with integrated Measuring System
 Clamping and Braking for Ball Rail Systems
 Rack and Pinion for Ball Rail Systems
 Miniature Ball Rail Systems
 Roller Rail Systems

Roller Rail Systems

Standard Ball Rail Systems
 Wide Ball Rail Systems
 Heavy Load Ball Rail Systems
 Ball Rail Systems with integrated Measuring System
 Clamping and braking units for Roller Rail Systems
 Rack and Pinion for Roller Rail Systems

Linear Bushings and Shafts

Linear Bushings, Linear Sets
 Blocks, Support Blocks

Ball Transfer Units
 Traditional Technical Parts

Screw Drives













Linear Systems

Linear Motion Slides	<ul style="list-style-type: none"> - Screw Drive - Toothed Belt Drive
Linear Module	<ul style="list-style-type: none"> - Screw Drive - Toothed Belt Drive - Rack and Pinion Drive - Pneumatic Drive - Linear Motor
Compact Module	<ul style="list-style-type: none"> - Screw Drive - Toothed Belt Drive - Linear Motor
Multi-axis Linear Motion Systems	
Precision Module	<ul style="list-style-type: none"> - Screw Drive
Ball Rail Table	<ul style="list-style-type: none"> - Screw Drive - Linear Motor

Controllers, Motors, Electrical Accessories





Linear Actuators





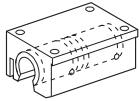
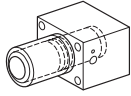
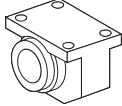
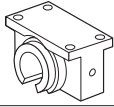

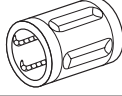
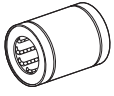
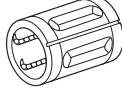
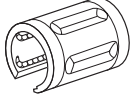
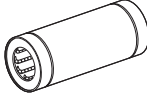

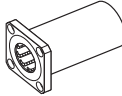
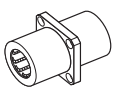

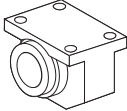
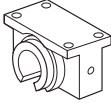
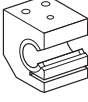

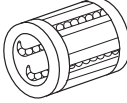
Linear Bushings and Shafts

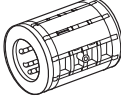
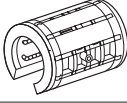
Selection Guide	9	
Product Overview	10	
Overall Dimensions	12	
Load Capacity	13	
Life Expectancy Calculation	14	
Lubrication	18	
Assembly	22	
Sizing Tables	24	
Compact Linear Bushings	26	
Compact Linear Sets	32	
Super Linear Bushings A and B	38	
Linear Sets with Super Linear Bushings A and B	54	
Standard Linear Bushings	76	
Linear Sets with Standard Linear Bushings	100	
Segmental Linear Bushings	110	
Linear Sets with Segmental Linear Bushings	116	
Super Linear Bushings H and SH	118	
Linear Sets with Super Linear Bushings H and SH	134	
Radial Linear Bushings	142	
Linear Sets with Radial Linear Bushings	150	
Radial Compact Sets	154	
Torque-resistant Linear Bushings	158	
Torque-resistant Compact Linear Bushings	166	
Linear Sets with Torque-resistant Linear Bushings	168	
Linear Bushings for combined Linear and Rotary motion	194	
Precision Steel Shafts	198	
Steel Shafts with assembled Shaft Support, Shaft Support	216	
Support Blocks	244	

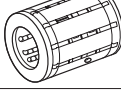
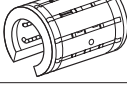
Contents

Compact Linear Bushings			
normal	R0658		30
RT			
corrosion-resistant			
<hr/>			
Compact Linear Sets			
closed, normal or corrosion-resistant	R1027		32
adjustable, normal	R1028		32
<hr/>			
Tandem	R1029		34
closed, normal or corrosion-resistant			
<hr/>			
closed, corrosion-resistant	R1707		36
<hr/>			
Super Linear Bushings 			
closed	R0670		50
<hr/>			
open	R0671		50
<hr/>			
Super Linear Bushings 			
closed	R0672		52
<hr/>			
open	R0673		52
<hr/>			
Linear Sets with Super Linear Bushings  or  Aluminum			
closed	R1035		56
adjustable	R1036		56
<hr/>			
open	R1037		58
open, adjustable	R1038		58
<hr/>			
side open	R1071		60
side open, adjustable	R1072		60
<hr/>			
Linear Sets with Super Linear Bushings  Tandem			
closed	R1085		62
<hr/>			
adjustable	R1032		62
<hr/>			
open	R1087		64
<hr/>			

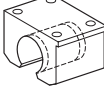
open, adjustable	R1034		64
Flange	R1083		66
Linear Sets with Super Linear Bushings A or B cast iron			
closed	R1065		68
adjustable	R1066		68
open	R1067		70
open, adjustable	R1068		70
side open	R1073		72
side open, adjustable	R1074		72
Flange	R1081		74
Standard Linear Bushings			
closed, without seal	R0600		84
closed, with seal	R0602		84
closed, without seal, corrosion-resistant	R0600		86
closed, with seal, corrosion-resistant	R0602		86
adjustable, without seal	R0610		88
adjustable, with seal	R0612		88
open, without seal	R0630		90
open, with seal	R0632		90
Tandem with seal, normal or corrosion-resistant	R0650		92
Flange with seal, normal or corrosion-resistant	R0740		94
Flange tandem with seal, normal or corrosion-resistant	R0741		96
Middle flange with seal, normal or corrosion-resistant	R0742		98

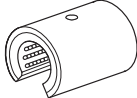

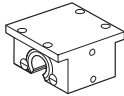
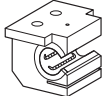
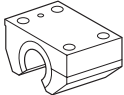
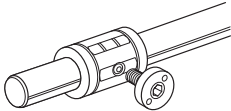
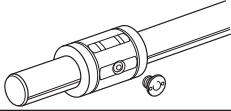
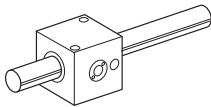
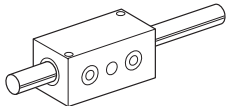
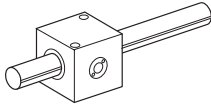
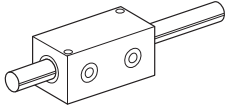
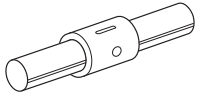
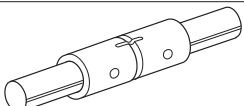
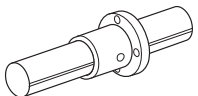

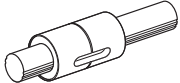
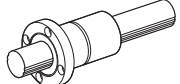
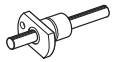
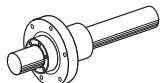
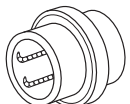
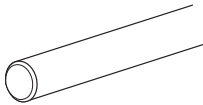
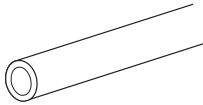
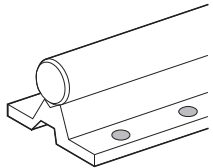
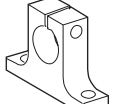
Linear Sets with Standard Linear Bushings	closed	R1065		102
	adjustable	R1066		102
	open	R1067		104
	open, adjustable	R1068		104
side open	R1073		106	
side open, adjustable	R1074		106	
Flange	R1081		108	
Segmental Linear Bushings	normal or corrosion-resistant	R0668		114
Linear Sets with segmental Linear Bushings	adjustable, normal or corrosion-resistant	R1060		116
Super Linear Bushings 	closed	R0732		130
open	R0733		130	
Super Linear Bushings 	closed	R0730		132
open	R0731		132	
Linear Sets with Super Linear Bushings  or 	closed	R1701		136
adjustable	R1702	136		
open	R1703		138	
open, adjustable	R1704		138	
side open, adjustable	R1706		140	
Radial Linear Bushings	without seal or completely sealed	R0678		148

Linear Sets with Radial Linear Bushings open open, adjustable	R1075		150
	R1076		150
side open side open, adjustable	R1077		152
	R1078		152
Radial Compact Sets open open, adjustable	R1611		156
	R1613		156
Torque-resistant Linear Bushings Type 1: one ball track Type 2: two ball track	R0696 0		164
	R0696 3		164
Torque-resistant Compact Linear Bushings Torque-resistant Compact Linear Bushings	R0720		166
Linear Sets with torque-resistant Linear Bushings, aluminium Type 1: one ball track Type 2: two ball track	R1098 2		170
	R1098 5		170
Tandem Type 1: one ball track Type 2: two ball track	R1099 2		172
	R1099 5		172
Linear Sets with torque-resistant Linear Bushings, Steel Type 1: one ball track Type 2: two ball track	R1096 2		174
	R1096 5		174
Tandem Type 1: one ball track Type 2: two ball track	R1097 2		176
	R1097 5		176
Linear Sets with torque-resistant Compact Linear Bushings	R0721		180
	R0722		182
	R0723		184

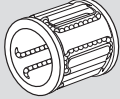
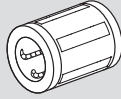
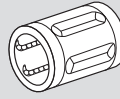
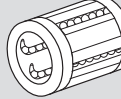
Torque-resistant Linear Bushings with four ball tracks	R0724		186
Flange	R0725		188
Miniature Flange	R0726		188
Rotating Flange	R0727		190
Linear Bushings for Linear and Rotary Motion with deep groove Ball Bearing (Ball Track Housing)	R0663		196
with deep groove Ball Bearing	R0664		196
with Roller Bearing, without seal	R0665		198
with Roller Bearing, with seal	R0667		198
Precision Steel Shafts Solid Shaft - Heat-treated steel or corrosion-resistant or hard chrome	R1000		214
Tubular Shaft - Heat-treated Steel or Hard Chrome	R1001		215
Steel Shafts with assembled Shaft Support, Shaft Support for open Standard and Super Linear Bushings with Flange, small overall height	R1010		224
for profiled systems	R1025		226
with flange, small overall height	R1014		228
with flange, large overall height	R1011		230
side installation	R1015		232
without flange	R1013		234
without flange, with fitting edge	R1016		236
for Radial Linear Bushings with flange	R1018		238
side installation	R1020		240
for Radial Compact Sets with flange, with fitting edge	R1012		242
Support Blocks Cast iron	R1055		246
Aluminium	R1057		248
Flange, cast iron	R1056		250
Compact Support Blocks	R1058		252
Compact Support Blocks, corrosion-resistant	R1059		254

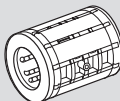
Product Selection Linear Bushings

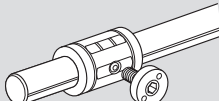
	Compact 	Super 	Standard 	Segmental 
Application frequency	+++	+++	++	++
Inexpensive	+++	++	++	+++
Easy assembly	+++	++	++	++
Very small dimensions	+++	+	+	+++
Also corrosion-resistant	+++	o	+++	+++
Normal Loads	+++	+++	+++	+++
High Loads	++	+++	++	++
Extreme Loads	o	o	o	o
With self-alignment	o	+++ ¹⁾	o	o
Especially smooth operation	++	+++	++	++
Also open	o	+++	+++	o
High temperature >100 °C	o	o	+++	o
Coarse contamination	o	o	+++	o
Suitable for vacuums	o	o	+++	o
Torque-resistant transfer	o	o	o	o
For Linear and Rotary Motion	o	o	o	o

	Super 	Radial 	Torque-resistant 	Linear and Rotary Motion 
Application frequency	+	+	+	+
Inexpensive	+	+	+	+
Easy assembly	+	+	+	++
Very small dimensions	+	o	+	+
Also corrosion-resistant	o	o	o	o
Normal Loads	+	+	+++	+++
High Loads	+	+	+++	++
Extreme Loads	+++	+++	o	o
With self-alignment	+++	o	o	o
Especially smooth operation	+	++	++	++
Also open	+++	+++	o	o
High temperature >100 °C	o	o	o	o
Coarse contamination	o	o	o	o
Suitable for vacuums	o	o	o	o
Torque-resistant transfer	o	o	+++	o
For Linear and Rotary Motion	o	o	o	+++

¹⁾ only Super 

+++ extremely suitable
 ++ very suitable
 + suitable
 o not suitable

Product Overview

Our wide product selection of Linear Bushings in this catalog ensures that you will find the right solution for every application.

The Compact Linear Bushing is distinguished by its compact dimensions. Through the use of integrated metal locking rings, this type eliminates the need for the otherwise typical axial fasteners in the mounting hole. The Compact Linear Bushing is also available in corrosion-resistant format or with reduced radial ventilation.



The Super-Linear Bushing **SL** is a built-in inertial error compensator, that compensates for the angle between the housing and shaft up to 0.5 degrees tilt without reducing the capacity due to angular pressure. Possible causes for internal errors include shaft flex due to heavy loads or inaccuracies in the connecting construction. The self-adjustment ensures effortless lead-in of the bearings into the loaded zone and even load distribution over the entire bearing row. This results in unparallelled smooth motion and a very high load capacity for the Linear Bushing.

For high loads or very long guide paths, the Super Linear Bushing can also be used on supported shafts. The super Linear Bushing without internal error compensation is the solution for applications where only one Linear Bushing per shaft is used and the Linear Bushing must not travel on the shaft.

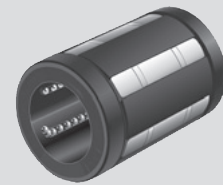

The standard Linear Bushing is especially durable due to its steel enclosure and is suitable for applications with high contamination, for example in the wood-working industry. It can be adjusted when closed, and is also available open. For applications with very high temperatures, standard Linear Bushings without seals are available. The closed standard Linear Bushing is also available complete corrosion-resistant steel and is especially good for applications in the vacuum packing and the food industry.



The Segmental Linear Bushing with its durable plastic housing, is a cost-effective, ready-to-install Linear Bushing. For applications in corrosive environments or high cleanliness standards, such as the food, semiconductor, or the medical Industries, this Linear Bushing also comes in a corrosion-resistant version.

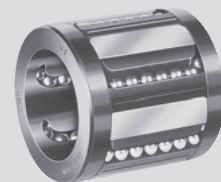

The Super Linear Bushings **SL** and **SL** the bearings are turned to the outside and proven Super Linear Bushing **SL** are equipped with even more steel inserts and bearing rows that provide even higher load capacity **SL** and very high load capacity **SL** and allow movement of especially heavy loads capable of self-alignment.

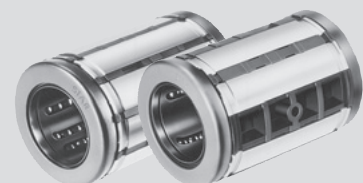

In radial linear bushings, the bearings are turned to the outside. The large number of long, supportive bearing rows result in high rigidity, making these the correct linear bearings for specialized machinery with higher loads.

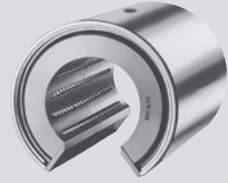

Torque linear bushings are a complete guide solution utilizing one shaft. The torque transfer takes place through more deeply set bearing circuits. Depending on the amount of transferred torque, these torque linear bearings are available with multiple roller channels.

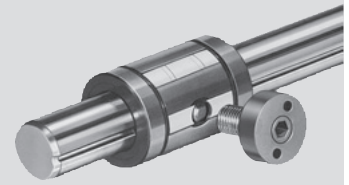

Linear Bushings for linear and rotary motion are available with deep-groove bearings or needle bearings. They are suitable for fluctuating motion as well as medium RPMs.



The Linear Sets are a complete set consisting of one housing with one or two Rexroth Linear Bushings. They are available in a variety of configurations. Through cost-effective manufacture, Linear Sets offer significant cost advantages compared to custom designs. The housings are easy to adjust during assembly, and therefore prevent any distortion of the Linear Bushings.

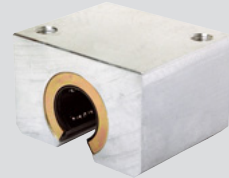

Precision steel supports come in various tolerances, as solid shafts, hollow shafts, tempered steel, corrosion-resistant steel or hard chromium. Rexroth delivers precision steel supports square cut to your specifications, with chamfering on both sides or machined to your drawings and/or specifications.

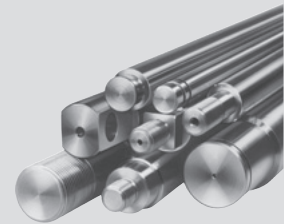

Steel supports with assembled shaft support, shaft supports, and support blocks in various versions complete the Linear Bushing guides.

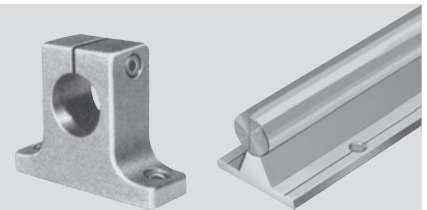

Overall Dimensions

Comparison of the various types of Linear Bushings

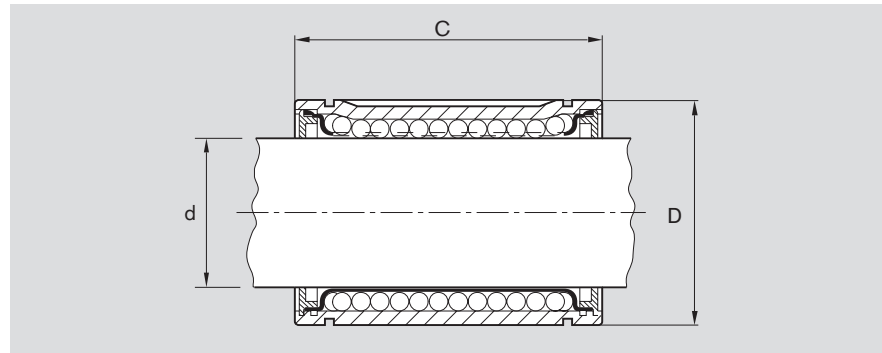

Linear Bushings Size [mm] Ø d	Compact-Linear Bushings Dimensions [mm]		Super Linear Bushings A, B Dimensions [mm]		Standard Linear Bushings Dimensions [mm]		Segmental Linear Bushings Dimensions [mm]		Super Linear Bushings H, SP Dimensions [mm]		Radial-Linear Bushings Dimensions [mm]	
	D	C	D	C	D	C	D	C	D	C	D	C
3	-	-	-	-	7	10	-	-	-	-	-	-
4	-	-	-	-	8	12	-	-	-	-	-	-
5	-	-	-	-	12	22	-	-	-	-	-	-
8	15	24	-	-	16	25	-	-	-	-	-	-
10	17	26	19	29	19	29	-	-	-	-	-	-
12	19	28	22	32	22	32	20	24	-	-	-	-
14	21	28	-	-	-	-	-	-	-	-	-	-
16	24	30	26	36	26	36	25	28	-	-	-	-
20	28	30	32	45	32	45	30	30	32	45	-	-
25	35	40	40	58	40	58	37	37	40	58	-	-
30	40	50	47	68	47	68	44	44	47	68	60	75
40	52	60	62	80	62	80	56	56	62	80	75	100
50	62	70	75	100	75	100	-	-	75	100	90	125
60	-	-	-	-	90	125	-	-	90	125	110	150
80	-	-	-	-	120	165	-	-	-	-	145	200

ISO 10285 Linear ball bearings, metric series

This standard contains the main dimensions, tolerances and definitions for linear ball bearings. It subdivides the Linear Bushings into dimension series and tolerance classes.

ISO 13012 Linear ball bearings, accessories

This standard clarifies the main dimensions and other functional dimensions of accessories for linear ball bearings - metric series.

Accessories are comprised of bearing housings, blocks, support blocks, shaft supports. They are used in conjunction with ISO 10285.

Capacities

Definition per DIN 636 Part1 Dynamic Capacity C

The radial load that is unchangeable in size and direction, which a Linear Bushing can support for a nominal life expectancy of 10^6 m traveled distance.

Note: The value for dynamic capacity assumes that the stroke of the linear bushing is at least three times its overall length. In some cases, the dynamic capacities in the tables may exceed the DIN values by up to 30%. These values have been confirmed in tests.

Static Capacity C_0

Static radial loading that represents a calculated demand of 5300 Mpa at the contact point in the center of the highest loaded contact point between roller bearing and the roller channel (shaft).

Note: The remaining total deformation of the roller bearings and roller channel (shaft) is approx. $1/10,000^{\text{th}}$ of the roller bearing diameter.

Nominal Lifespan

The 90% historical probability achievable calculated life expectancy for a single roller bearing or a group of clearly identical bearings operated under identical conditions, using currently conventional material of typical manufacturing quality and standard operating conditions.

Additional Parameters Load Direction

If the load direction and orientation of linear bushing is not clearly defined, the minimum values for capacities should be used in calculations. The maximum capacity can only be used when the bearings are oriented in the load direction. For closed and adjustable Linear Bushings, the minimum and/or maximum capacities are listed in the tables according to type. Open bearings must be locked. In this case, the listed capacity of the main load direction is perpendicular across from the opening.

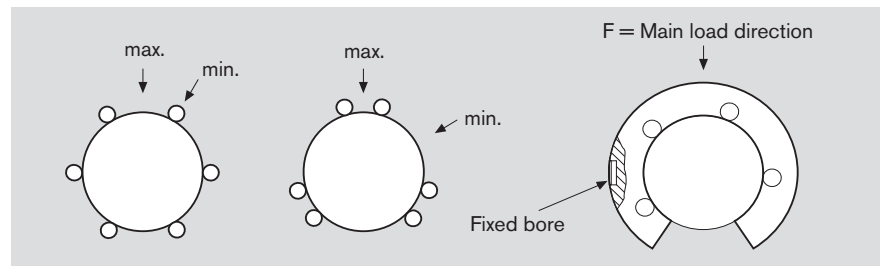

Nominal Lifespan

$$L = \left(\frac{C}{F} \cdot f_H \cdot f_t \right)^3 \cdot 10^5$$

$$L_h = \frac{L}{2 \cdot s \cdot n \cdot 60}$$

L	=	Nominal Lifespan	[m]
C	=	Dynamic Capacity	[N]
F	=	Dynamic Equivalent Load	[N]
f_H	=	Hardness Factor of the shaft	
f_t	=	Temperature Factor	
L_h	=	Nominal Lifespan	[h]
s	=	Stroke Length	[m]
n	=	Stroke Cycle	[s/min]
		(Double Stroke)	[min ⁻¹]

Lifespan Calculation

Hardness of the shaft

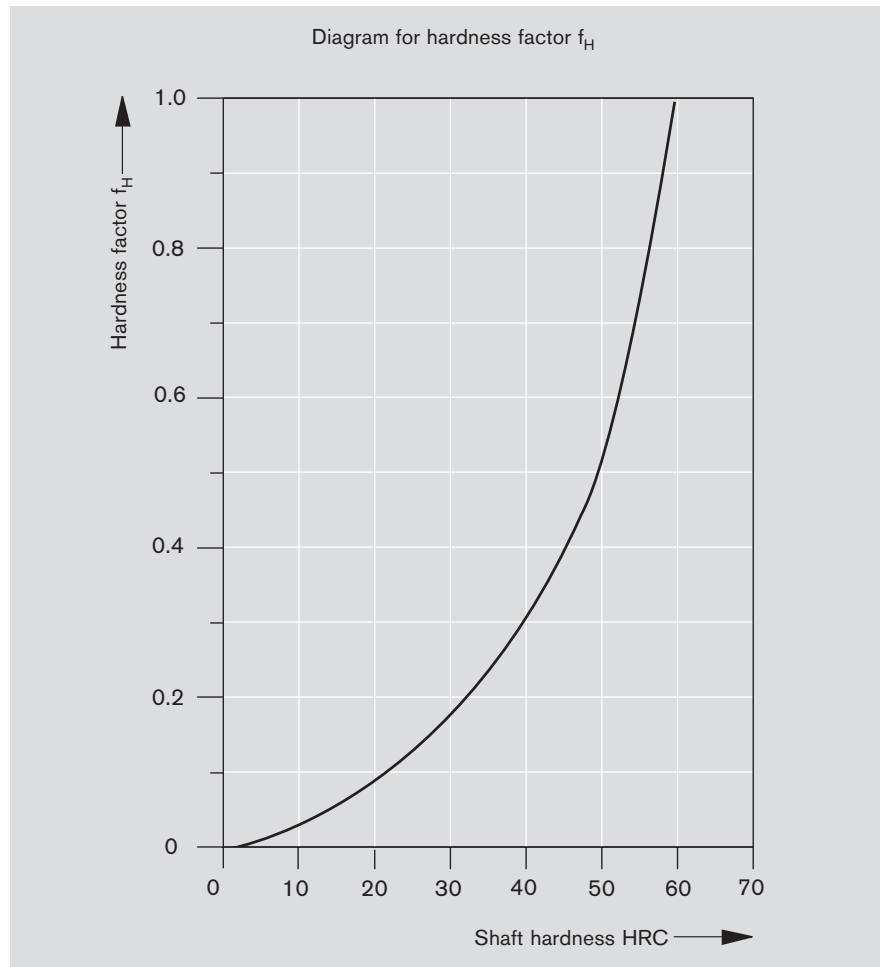

Temperature factor

Bearing temperature [°C]	100	125	150	175	200
Temperature factor f_t	1	0.92	0.85	0.77	0.70

Dynamic equivalent bearing load

By varying Bearing load in the same load direction, the dynamic equivalent load F is calculated as follows:

$$F = \sqrt[3]{F_1^3 \cdot \frac{q_1}{100} + F_2^3 \cdot \frac{q_2}{100} + \dots + F_n^3 \cdot \frac{q_n}{100}}$$

F	=	dynamic equivalent load	[N]
$F_1, F_2 \dots F_n$	=	staged, dynamic single loads	[N]
$q_1, q_2 \dots q_n$	=	path sections for $F_1, F_2 \dots F_n$	[%]

In the event of varying load directions, the resulting load is to be confirmed. Preload and resulting tipping forces must also be taken into consideration when calculating the lifespan.

Short Stroke

For Compact, Super and Segmental Linear Bushings with a stroke length of less than three times the length of the linear bushing, use the short stroke value. In this case, the life span of the shaft is shorter than the bushing. For further information, see technical data, Linear bushings.

Capacity determination

For designs, you can calculate with the following formula:

$$C = \frac{F}{f_H \cdot f_t \cdot f_L}$$

- C = Dynamic Capacity [N]
- F = Dynamic Equivalent bearing load [N]
- f_H = Hardness factor of the shaft
- f_t = Temperature factor
- f_L = Life span factor

Influence of the Lifespan

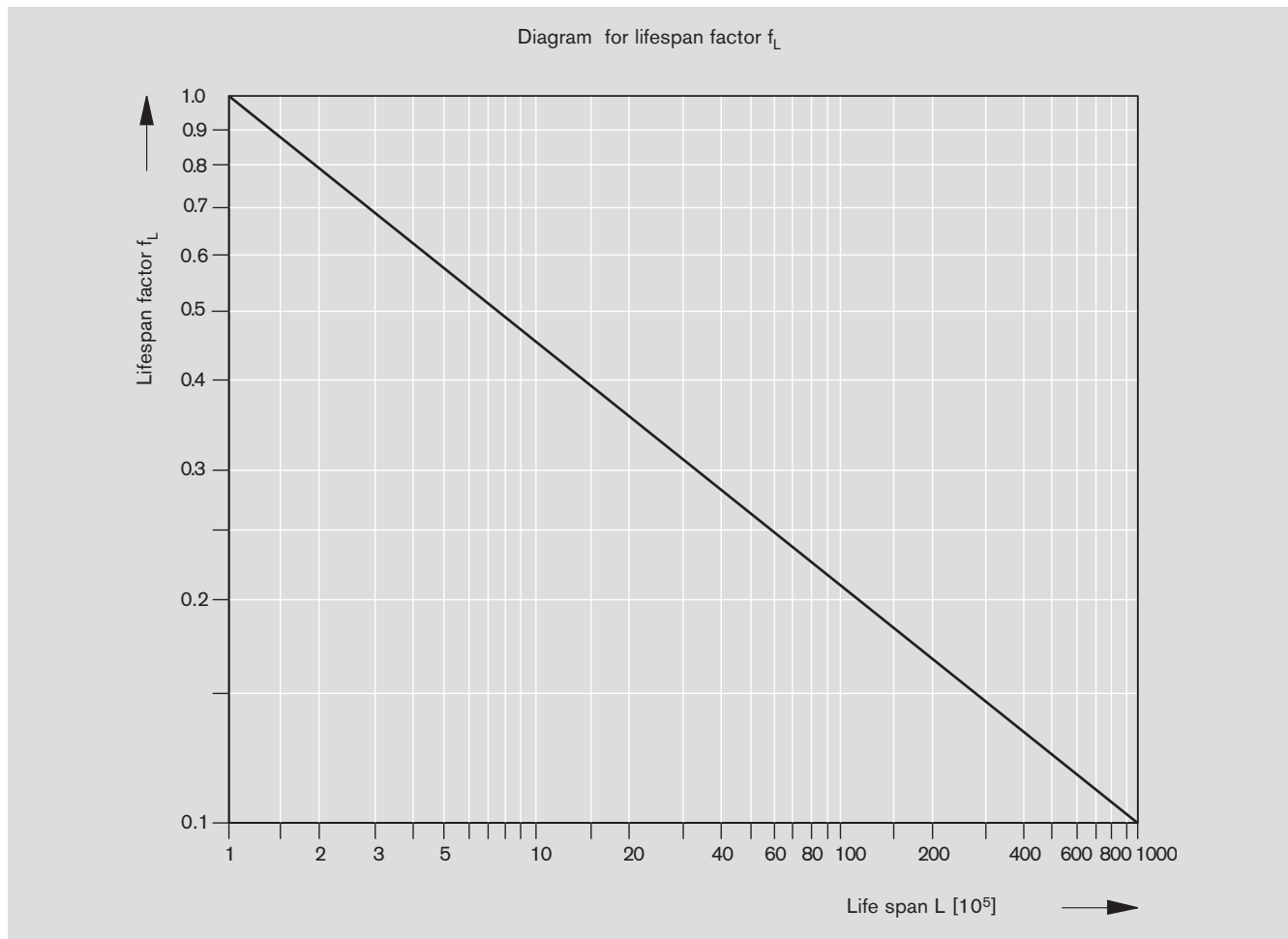

Life Span Calculations

Dynamic Capacities

Linear Bushing sizes [mm] Ø d	Compact Linear Bushing	Super Linear Bushing A, B	Standard Linear Bushing	Segment Linear Bushing	Super Linear Bushing 1) 2)		Radial Linear Bushing
	[N]	[N]	[N]	[N]	[N]	[N]	[N]
	C	C	C	C	C	C	C
3	-	-	55	-	-	-	-
4	-	-	70	-	-	-	-
5	-	-	180	-	-	-	-
8	500	-	320	-	-	-	-
10	600	600	300	-	-	-	-
12	730	830	420	480	-	-	-
14	760	-	-	-	-	-	-
16	950	1020	580	720	-	-	-
20	1120	2020	1170	1020	2520	3530	-
25	2330	3950	2080	1630	4430	6190	-
30	3060	4800	2820	2390	6300	8800	8500
40	5040	8240	5170	3870	9680	13500	13900
50	5680	12060	8260	-	16000	22300	20800
60	-	-	11500	-	23500	-	29500
80	-	-	21000	-	-	-	54800

¹⁾ The shown capacities reflect maximum values, as position and load direction can be pre-defined.

Note to dynamic Capacities

The figures for dynamic load carrying capacity have been calculated assuming a nominal travel of 100,000 m. For a nominal travel of 50,000 m, the "C" figures in the table must be multiplied by a factor of 1.26.

Calculation Example

The loading of a carriage perpendicular to both shafts in 800N. It is assumed that the load on the four Linear Bushings is evenly distributed. The carriage travels along a section of $x = 0.2$ m with a frequency of $n = 30$ double strokes per minute. The minimum lifespan should be $L_h = 8000$ hours. The operating temperature is less than 100°C . Precision steel shafts with a minimum HRC 60 and Compact Linear Bushings should be used.

Determining the Linear Bushing size:

Load per Linear Bushing:

$$F = \frac{800}{4} = 200 \text{ N}$$

Lifespan L as total travel in meters:

$$L = 2 \cdot s \cdot n \cdot 60 \cdot L_h \text{ [m]}$$

$$L = 2 \cdot 0,2 \cdot 30 \cdot 60 \cdot 8000 \text{ [m]}$$

$$L = 57.6 \cdot 10^5 \text{ m}$$

The lifespan factor $f_L = 0.25$ for a lifespan of $57.6 \cdot 10^5$ can be read from the diagram (for lifespan factor f_L).

For shaft hardness HRC 60, the "Diagram for hardness factor f_H " yields the hardness factor $f_H = 1$. The temperature factor f_t according to the table $f_t = 1$.

The necessary capacity C therefore yields:

$$C = \frac{F}{f_H \cdot f_t \cdot f_L} = \frac{200}{1 \cdot 1 \cdot 0.25} = 800 \text{ N}$$

The Linear Bushing with the next highest capacity would be, for example R0658 216 40.

The dynamic capacity is $C_{min} = 950$ N, the static capacity is $C_{0min} = 500$ N.

Calculation of the nominal lifespan

For the selected Linear Bushing R0658 216 40 can be calculated using the following values.

$$L = \left(\frac{C}{F} \cdot f_H \cdot f_t \right)^3 \cdot 10^5 \text{ [m]}$$

the nominal lifespan can be calculated in meters with the following values:

$$\text{Dynamic Load Capacity} \quad C = 950 \text{ N}$$

$$\text{Load per Linear Bushing} \quad F = 200 \text{ N}$$

$$\text{Hardness factor} \quad f_H = 1$$

$$\text{Temperature factor} \quad f_t = 1$$

$$\text{Lifespan} \quad L = \left(\frac{950}{200} \cdot 1 \cdot 1 \right)^3 \cdot 10^5 \text{ [m]}$$

$$L = 107 \cdot 10^5 \text{ [m]}$$

Converted to operating hours, the following formula gives the lifespan in hours:

$$L_h = \frac{L}{2 \cdot s \cdot n \cdot 60}$$

$$L_h = \frac{107 \cdot 10^5}{2 \cdot 0,2 \cdot 30 \cdot 60}$$

$$L_h = 14861 \text{ Hours}$$

Standard lubrication practices as applied for anti-friction bearings can also be used for all linear bushings. Linear Bushing are delivered already filled with an anti-corrosion agent that is compatible with all petroleum-based lubricants. Either oil or grease can be used as a lubricant. In most cases, the use of grease as a lubricant is preferable. The advantage of using grease rather than oil is that, being more viscous, grease helps to seal off the linear bushing and adheres better to the surfaces inside the bushing. In-service lubrication is therefore only required at long intervals. Please observe the lubricant manufacturer's instructions for use. Linear Sets have been designed for use with grease lubricants. If oil is used instead, it is essential to check that all bushing surfaces and rolling elements are properly coated with lubricant.

Oil Lubricants

We recommend the use of a grease per DIN 51825 as a lubricant
K2K
KP2K (for higher loads).

Oil Lubricants

If exceptionally smooth movement is required, oil may be used as a lubricant for the the linear bushings.

Different types of oil and their viscosity ratings are listed below:

ISO-Viscosity class to DIN 51519	Kinematic viscosity at 40 °C [mm ² /s]	Application
ISO VG 32	32	for low friction and light loads
ISO VG 68	68	
ISO VG 100	100	for low velocities and/or higher loads
ISO VG 320	320	
ISO VG 460	460	

Initial greasing and Maintenance Lubrication

Initial greasing and maintenance lubrication via lubrication ports:
Lubricate with shaft retracted, until lubricant appears.

Example:

Super Linear Bushing : Ø25
Dynamic Capacity C: 3950 N (min. Position)
Load: ~ 25 % of the dyn. Capacity (F/C)

Based on the chart, maintenance lubrication should be performed after 1450 km of operation.

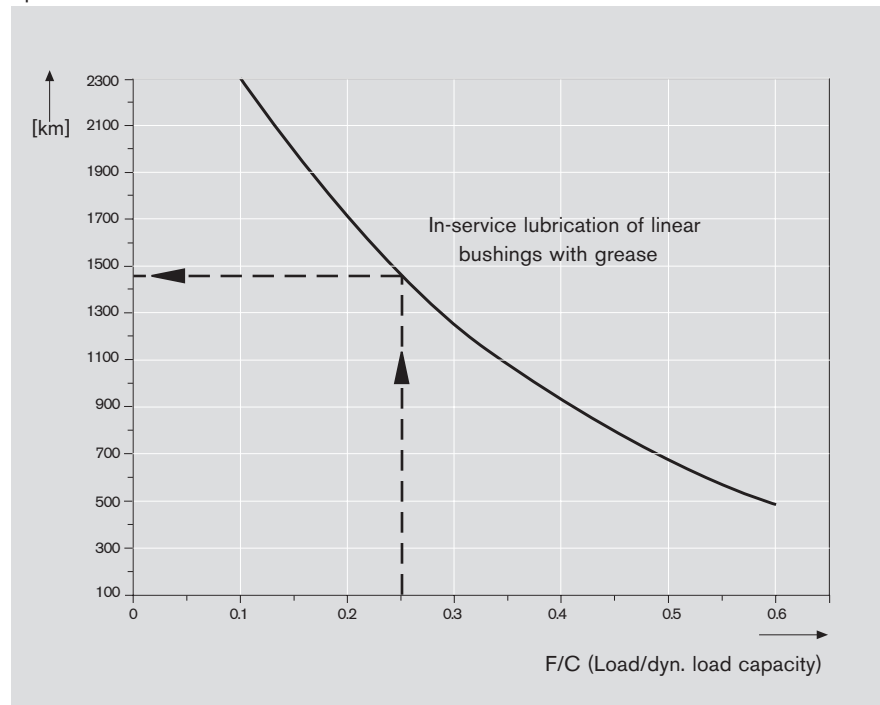

The chart gives guide values for in-service lubrication. Practical experience has shown that longer lubrication intervals can be readily achieved. These values presuppose careful initial greasing and regular checks on the condition of the lubricant.

There are many factors that affect in-service lubrication or a change of grease in Linear Bushings.

Some of these factors are listed below:

- Load
- Velocity
- Motion sequence
- Temperature

Short lubricating intervals are required in the following cases:

- Higher loads
- Higher velocity (to v_{max})
- Short stroke (stroke s is shorter than the length of the Linear Bushing)
- Low resistance to aging in the lubricant

Lubrication

Linear bushing in-service lubrication options

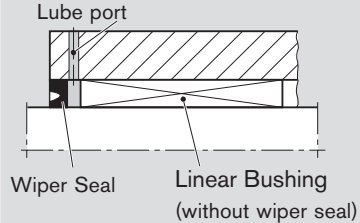
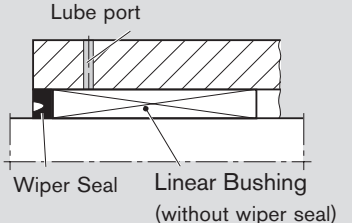
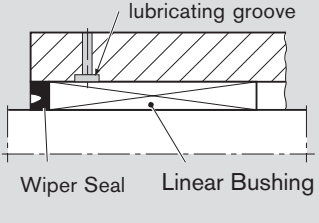
Types of Linear Bushing	Lubrication through gap between Linear Bushing and wiper seal	Lubrication through lube port	Lubrication through lube port with lubricating groove
			
Compact			<p>●</p> <p>Locate the lube port along the visible ball recirculating track</p>
Super A , B			
– closed	●	See Super Linear Bushings A , B – Technical data	
– open	●	– "Customer-built housing"	
Standard			
– closed	●		
– adjustable	●	<p>●</p> <p>Locate the lube port near the slot (alignment during installation)</p>	
– open	●		
Segmental	●		<p>●</p> <p>Locate the lube port along the visible ball recirculating track</p>
Super H , SH	See Super Linear Bushings H , SH – Technical data – "Customer-built housing"		
Radial		Lube port - see Radial Linear Bushings	
	Axial retention of wiper seal and linear bushing required	Lubrication causes pressure to build up. Always check that the linear bushing and the wiper seal fit tightly.	

Note:

Ensure that there is sufficient retention in open-type versions. Whenever possible, apply lubricant during longitudinal motion. Lube ports and lube grooves must be free of burrs.

Grease Nipples

Linear sets designed for in-service lubrication are provided with lube holes for grease lubrication. Suitable grease nipples are shown in the table below:

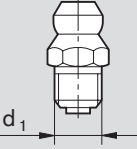
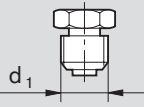
$\varnothing d_1$ [mm]	 Cone-type grease nipple DIN 71412 Form A Part Numbers	 Funnel-type grease nipple DIN 3405 Form A Part Numbers
M6	R3417 002 02	R3417 001 05
M8 x 1	R3417 003 02	R3417 003 05
M10 x 1	R3417 009 02	-

Mounting Instructions

Installation of Linear Bushings

Two linear bushings are required for linear motion assemblies using one shaft only. Assemblies with two shafts must have at least one of the shafts mounted in two linear bushings.

Parallelism

To prevent distortion, which would increase running friction and shorten the service life of the assembly, special care must be taken to ensure precise spacing and parallelism between the two shafts with their respective linear bushings.

Recommended values for maximum spacing inaccuracy P, including deviation from parallelism, for assemblies incorporating linear bushings are as follows:

Shaft Ø d [mm]	P [µm]			
	Zero-clearance		h7/H7	
	Standard-Super-Radial-Linear Bushing	Segmental-Compact-Linear Bushing	Standard-Super-Linear Bushing	Segmental-Compact- ¹⁾ Linear Bushing
3	3	–	9	–
4	3	–	9	–
5	4	–	12	–
8	4	7	12	15
10	4	7	12	15
12	5	8	13	17
14	5	8	13	17
16	5	8	13	17
20	7	12	15	20
25	9	15	17	23
30	9	15	17	23
40	11	18	19	25
50	13	22	21	28
60	16	–	24	–
80	22	–	30	–

¹⁾ For the "RE Compact" type the values in the "Zero-clearance" column apply.



Operating Temperatures

–20 °C to +100 °C

Standard-Linear Bushing with wiper seals and separate wiper seals for Radial Linear Bushings: –20 °C to +80 °C (with brief peaks up to +100 °C)

Higher temperatures are permissible only for sized 12 to 80 standard Linear Bushings with seals and at the cost of a reduction in load carrying capacity.

Shaft deflection

In assemblies with rigid housings etc., and long distances between shaft supports, shaft deflection and resultant pressure between the bushing edge and the shaft will shorten the life of the assembly (this does not apply to Super Linear Bushings  and  up to 30'). For information on how to calculate shaft deflection, see Technical Data on precision steel shafts.

Corrosion-resistant Linear Bushings

Corrosion-resistant steels are steels to ISO 683-17/ EN 10088.

In very critical, corrosive environments the parts must be checked under operating conditions. Use appropriate anti-corrosive agents and lubricants.

Housing Bores

The operating play for all Linear Bushings can be affected by the selection of the shaft and bore tolerances (except closed Standard Linear Bushings). For normal operating play per DIN, the housing bore has a tolerance of H7. For small and larger bores, the operating play changes accordingly. For low-play guidance, we recommend bores with a tolerance of K7 or K6. For light preload, bore tolerances M7 and M8 are suitable. (Preload reduces the lifespan of the Linear Bushings and the Shafts).

Radial clearance	The radial clearance values given in the tables have been obtained by statistical methods and are representative of the clearances to be expected in actual practice.
Adjusting the radial clearance	If an application calls for zero clearance, the radial clearance must be reduced by means of an adjusting screw in the bushing housing until a slight resistance is felt when the shaft is turned. In applications subject to vibration, the adjusting screw should be suitably secured against working loose once the desired clearance has been established. The radial clearance of the closed-type Standard Linear Bushing is not adjustable.
Preload	If negative clearance (preload) is required, we recommend that zero clearance should be established as described above using a dummy shaft whose diameter is smaller by the amount of the desired preload than the actual guide shaft on which the linear bushing is to run.
Vertical Dimensions	The tables for Linear Sets contain tolerance values for the height dimension 'H'. These tolerance values have been obtained by statistical methods and are representative of the values to be expected in actual practice.
Fasteners	See "Technical data" of various Linear Bushings.
Points to note when mounting	<p>The edge of the housing bore must be chamfered. The smaller sizes of linear bushing (but not the Compact series) can be inserted by hand.</p> <p>Use of an arbor is recommended for larger diameters and for the Compact Linear Bushings. Care should be taken not to exert pressure on the wiper seals and steel holding rings (Standard Linear Bushings), as this could damage the ball retainers. If a Compact Linear Bushing is slightly skewed on entering the housing bore, it will align itself as it is inserted further. Removal and re-alignment are unnecessary.</p> <p>Likewise, to prevent damage to the ball retainers and seals, care must be taken to ensure that the ends of the shaft are chamfered and that the Linear Bushing is not tilted when it is pushed onto the shaft.</p> <p>Hammers should never be used on the sleeve, holding rings or ball retainers of linear bushings, as this will invariably cause damage to the bushing.</p> <p>Linear bushings with seals must not be pushed onto the shaft over sharp edges, as the lips of the seals are extremely sensitive to damage.</p> <p>Radial and Torque-Resistant Linear Bushings must be mounted as described in the "Mounting instructions" in the relevant section.</p>

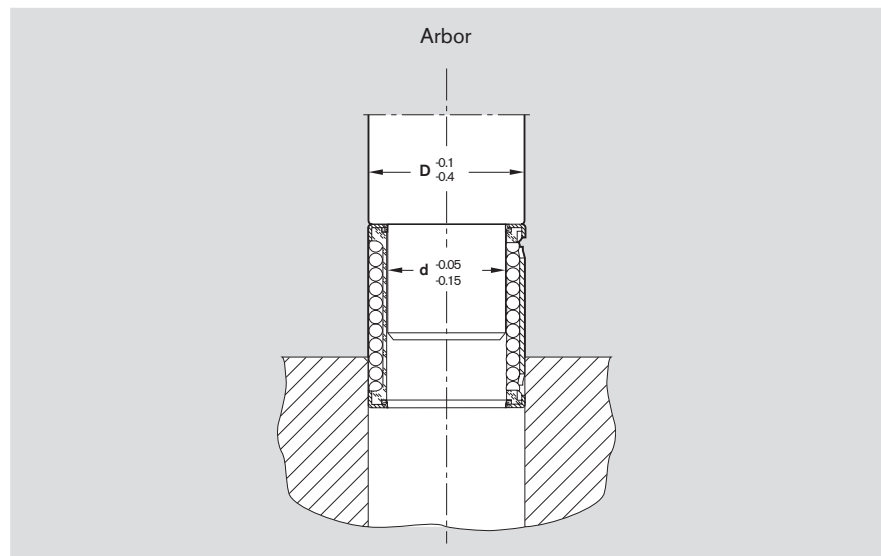

Tolerance Tables

Tolerance for inner dimensions

Rated dimensions [mm]	Tolerance for inside dimensions [μm] = 0.001 mm															
	G7	H5	H6	H7	H8	H11	H12	H13	JS6	JS7	JS14	K6	K7	M6	M7	P9
> 3	+16	+5	+8	+12	+18	+75	+120	+180	+4	+6	+150	+2	+3	-1	0	-12
≤ 6	+4	0	0	0	0	0	0	0	-4	-6	-150	-6	-9	-9	-12	-42
> 6	+20	+6	+9	+15	+22	+90	+150	+220	+4.5	+7.5	+180	+2	+5	-3	0	-15
≤ 10	+5	0	0	0	0	0	0	0	-4.5	-7.5	-180	-7	-10	-12	-15	-51
> 10	+24	+8	+11	+18	+27	+110	+180	+270	+5.5	+9	+215	+2	+6	-4	0	-18
≤ 18	+6	0	0	0	0	0	0	0	-5.5	-9	-215	-9	-12	-15	-18	-61
> 18	+28	+9	+13	+21	+33	+130	+210	+330	+6.5	+10.5	+260	+2	+6	-4	0	-22
≤ 30	+7	0	0	0	0	0	0	0	-6.5	-10.5	-260	-11	-15	-17	-21	-74
> 30	+34	+11	+16	+25	+39	+160	+250	+390	+8	+12.5	+310	+3	+7	-4	0	-26
≤ 50	+9	0	0	0	0	0	0	0	-8	-12.5	-310	-13	-18	-20	-25	-88
> 50	+40	+13	+19	+30	+46	+190	+300	+460	+9.5	+15	+370	+4	+9	-5	0	-32
≤ 80	+10	0	0	0	0	0	0	0	-9.5	-15	-370	-15	-21	-24	-30	-106
> 80	+47	+15	+22	+35	+54	+220	+350	+540	+11	+17.5	+435	+4	+10	-6	0	-37
≤ 120	+12	0	0	0	0	0	0	0	-11	-17.5	-435	-18	-25	-28	-35	-124
> 120	+54	+18	+25	+40	+63	+250	+400	+630	+12.5	+20	+500	+4	+12	-8	0	-43
≤ 180	+14	0	0	0	0	0	0	0	-12.5	-20	-500	-21	-28	-33	-40	-143
> 180	+61	+20	+29	+46	+72	+290	+460	+720	+14.5	+23	+575	+5	+13	-8	0	-50
≤ 250	+15	0	0	0	0	0	0	0	-14.5	-23	-575	-24	-33	-37	-46	-165

Conversion table from millimeters to inches

	Millimeters	μm	Inches
1 Millimeter	1	1000	0.0393701
1 μm	0.001	1	$3.93701 \cdot 10^{-5}$
1 inch	25.4	25400	1

Conversion example of μm to inches:

What are the tolerances (in inches) for a bore with a diameter of 3.5 inches?

Bore diameter 3.5 inches = $3.5 \cdot 25.4 \text{ mm} = 88.9 \text{ mm}$

For a bore diameter of 88.9 mm with a tolerance range of H7, the upper tolerance limit is +35 μm and the lower tolerance limit is 0 μm.

Max. offsize = $+35 \mu\text{m} = +35 \cdot 3.93701 \cdot 10^{-5} \text{ inch} = 1.3779 \cdot 10^{-3} \text{ inch}$

Min. offsize = 0 μm

Tolerance for outer dimensions

Rated dimensions [mm]	Tolerance for outside dimensions [μm] = 0.001 mm															
	g7	h5	h6	h7	h8	h11	h12	h13	js6	js7	js14	k6	k7	m6	m7	p9
> 3	-4	0	0	0	0	0	0	0	+4	+6	+150	+9	+13	+12	+16	+42
\leq 6	-16	-5	-8	-12	-18	-75	-120	-180	-4	-6	-150	+1	+1	+4	+4	+12
> 6	-5	0	0	0	0	0	0	0	+4.5	+7.5	+180	+10	+16	+15	+21	+51
\leq 10	-20	-6	-9	-15	-22	-90	-150	-220	-4.5	-7.5	-180	+1	+1	+6	+6	+15
> 10	-6	0	0	0	0	0	0	0	+5.5	+9	+215	+12	+19	+18	+25	+61
\leq 18	-24	-8	-11	-18	-27	-110	-180	-270	-5.5	-9	-215	+1	+1	+7	+7	+18
> 18	-7	0	0	0	0	0	0	0	+6.5	+10.5	+260	+15	+23	+21	+29	-
\leq 30	-28	-9	-13	-21	-33	-130	-210	-330	-6.5	-10.5	-260	+2	+2	+8	+8	-
> 30	-9	0	0	0	0	0	0	0	+8	+12.5	+310	+18	+27	+25	+34	-
\leq 50	-34	-11	-16	-25	-39	-160	-250	-390	-8	-12.5	-310	+2	+2	+9	+9	-
> 50	-10	0	0	0	0	0	0	0	+9.5	+15	+370	+21	+32	+30	+41	-
\leq 80	-40	-13	-19	-30	-46	-190	-300	-460	-9.5	-15	-370	+2	+2	+11	+11	-
> 80	-12	0	0	0	0	0	0	0	+11	+17.5	+435	+25	+38	+35	+48	-
\leq 120	-47	-15	-22	-35	-54	-220	-350	-540	-11	-17.5	-435	+3	+3	+13	+13	-
> 120	-14	0	0	0	0	0	0	0	+12.5	+20	+500	+28	+43	+40	+55	-
\leq 180	-54	-18	-25	-40	-63	-250	-400	-630	-12.5	-20	-500	+3	+3	+15	+15	-
> 180	-15	0	0	0	0	0	0	0	+14.5	+23	+575	+33	+50	+46	+63	-
\leq 250	-61	-20	-29	-46	-72	-290	-460	-720	-14.5	-23	-575	+4	+4	+17	+17	-

Note:

This catalog refers to the new ISO standards throughout. In some cases, however, the old standards are still used in actual practice. The correspondence between standards is given below.

	New designation	Old designation
Hex socket	ISO 4762	DIN 912
Head cap screws		
Hexagon head screws	ISO 4017	DIN 933

Compact Linear Bushings

The Advantages

- Low cost Linear Bushing for most applications
- Small overall dimensions for especially compact construction
- Integrated metal retainer rings with approx. 0.1 mm oversize on the outer diameter (sizes 12 to 50) for secure placement in the housing bore
- Easy assembly:
Just press in – no additional retention necessary
- Hardened steel segments with ball lubrication in the tracks for high capacity and long lifespan
- High travel speeds (5 m/s)
- Several cavities/ports serve as lubricant reservoir for long lubrication intervals or extended lubrication
- The cavities can also capture invading dirt, preventing the potential blockage of the Linear Bushing
- Integrated seals, external seals or without seals
- Low radial clearance (RT) for zero-clearance guidance
- Also available in corrosion-resistant versions for the medical, chemical and food industries
- Linear sets with aluminum or corrosion-resistant steel housing

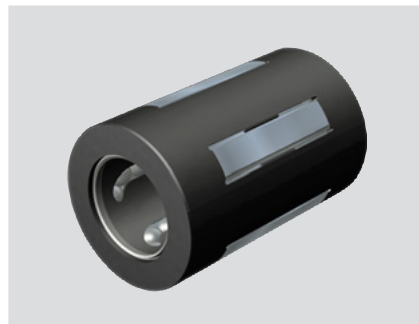

Shaft diameter 8 and 10



Shaft diameter 12 to 50

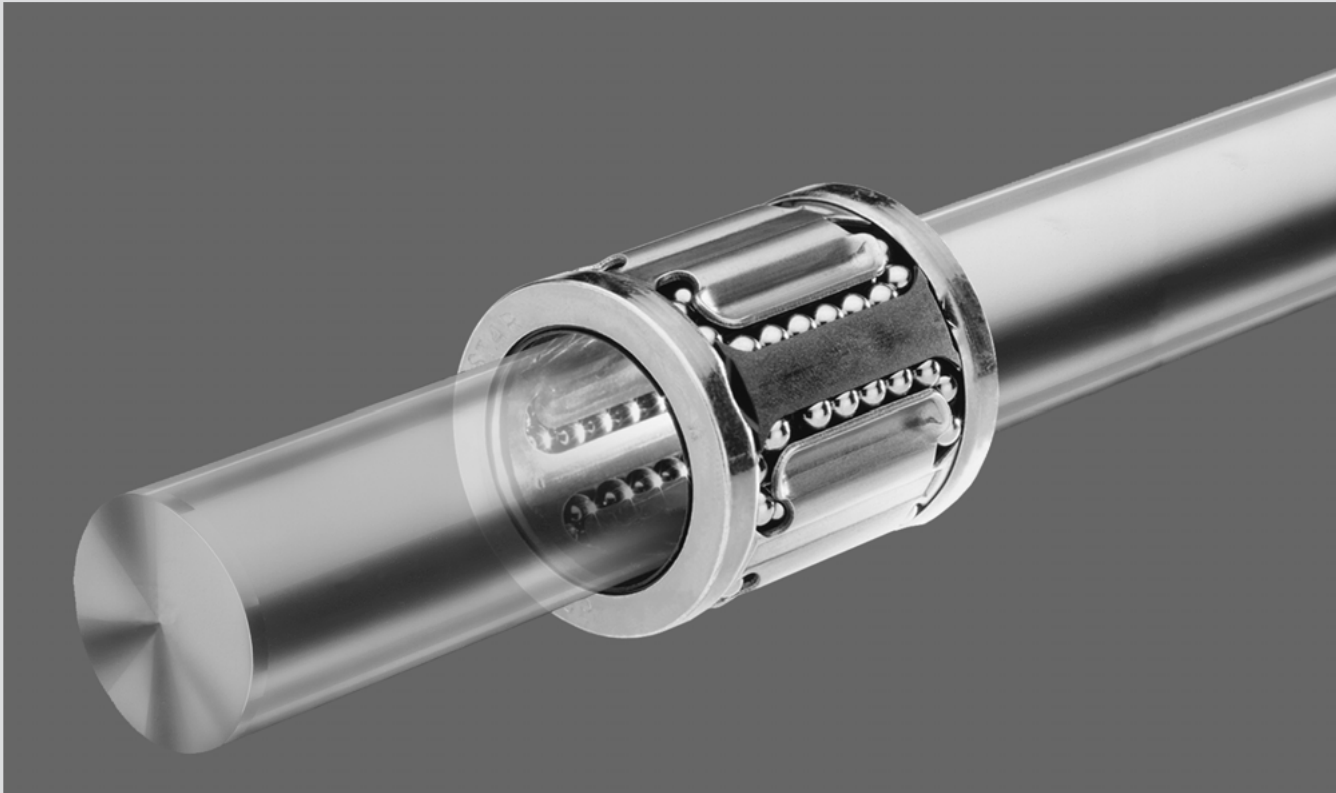

Compact Linear Bushings

Technical Data, Mounting Instructions

Please observe the general technical principles and mounting instructions at the beginning of this catalog as well as the additional technical data given below.

Sealing

The sealed standard types are fitted with integral wiper-type seals. Separate end seals can also be ordered (no special retaining elements necessary).

Friction

The friction μ of unsealed Compact Linear Bushings using oil as a lubricant lies between 0.001 - 0.004. The friction is lowest under high load. It may, however, be greater than the stated value when only a slight load is applied. For Compact Linear Bushings fitted at both ends with internal wiper seals and not subject to radial loading, the frictional drag (see table below) depends on the speed and the type of lubrication.

Shaft \varnothing d [mm]	Breakaway force ¹⁾ (N approx.)	Friction drag ¹⁾ (N approx.)
8	0.8	0.4
10	1	0.5
12	1.5	0.8
14	1.8	0.9
16	2	1
20	3	1.5
25	4.5	2
30	6	2.5
40	8	3
50	10	4

¹⁾ For separate wiper seals, the values must be multiplied by a factor of 1.5.

Velocity

$$v_{\max} = 5 \text{ m/s}$$

Acceleration

$$a_{\max} = 150 \text{ m/s}^2$$

Operating Temperature

$$-20 \text{ }^{\circ}\text{C to } 100 \text{ }^{\circ}\text{C}$$

Direction of load and its influence on the load capacity

The load capacities give are valid for installation in "min" position and should be taken as the basis for calculation.

In applications where the direction of load is exactly known and where the Compact Linear Bushings can be mounted in the "max" position, the load capacity rating must be multiplied by the factors f_{max} (dynamic load capacity C) or f_{0max} (static load capacity C_0).

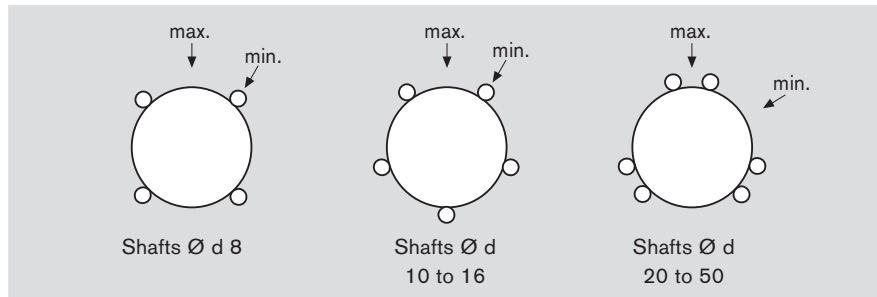

Reduced load capacity in short-stroke applications

In short-stroke applications, the service life of the shafts is shorter than that of the Compact Linear Bushings. For this reason, the load capacities C listed in the tables must be multiplied by the factor f_w .

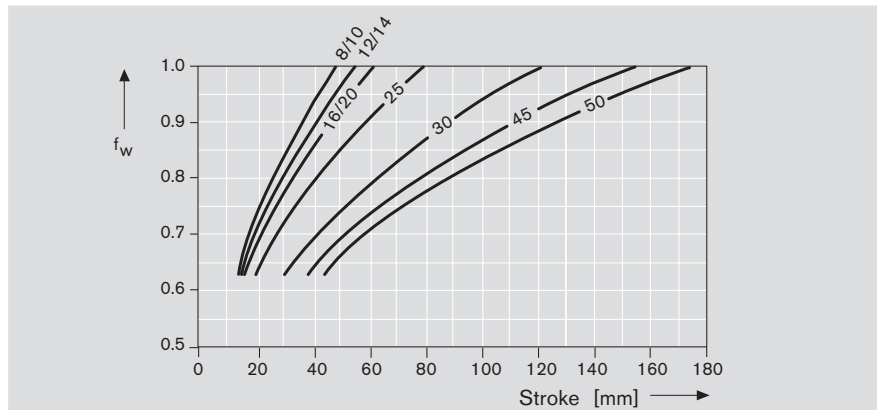

Notes for mounting

Use of an arbor is recommended for installation of Compact Linear Bushings into the housing bore (see "Mounting Instructions" in the General Technical Data at the beginning of this catalog). If a Compact Linear Bushing is slightly skewed on entering the housing bore, it will align itself as it is inserted further. Removal of the Compact Linear Bushing and re-alignment are unnecessary.

Retention

Shafts Ø 8 and 10: The plastic outer shell is oversized. For applications with vibration or higher acceleration, additional retention is needed.
 Shafts Ø 12 to 50: The outer diameter of the Metal retainer ring is oversized.

No additional retention is necessary (bore length $\geq C$).

Compact Linear Bushings

Compact Linear Bushing, R0658
normal

Structural Design

- Ball retainer made of POM
- Without seals
- Internal/separate seals
- Balls made of anti-friction bearing steel
- Hardened steel segmental load bearing plates
- Metal holding rings (from Shaft \varnothing 12 mm)



Compact - RT Type

With reduced radial clearance for applications requiring low-clearance operation with H7 bores.

Corrosion-resistant
(anti-friction bearing steel to ISO 683-17 / EN 10088)

Structural Design

- Balls made of corrosion-resistant anti-friction bearing steel
- Corrosion-resistant steel segmental load bearing plates
- Corrosion-resistant steel retainer rings (from Shaft \varnothing 12 mm)

Shafts \varnothing d [mm]	Part numbers without seals			Mass [kg]
	Normal	RT	Corrosion-resistant	
8	R0658 008 00	R0658 062 00	R0658 008 30	0.011
10	R0658 010 00	R0658 061 00	R0658 010 30	0.014
12	R0658 012 00	R0658 051 00	R0658 012 30	0.016
14	R0658 014 00	R0658 058 00	R0658 014 30	0.018
16	R0658 016 00	R0658 052 00	R0658 016 30	0.025
20	R0658 020 00	R0658 053 00	R0658 020 30	0.028
25	R0658 025 00	R0658 054 00	R0658 025 30	0.058
30	R0658 030 00	R0658 055 00	R0658 030 30	0.080
40	R0658 040 00	R0658 056 00	R0658 040 30	0.140
50	R0658 050 00	R0658 057 00	R0658 050 30	0.170



Shaft \varnothing d [mm]	Part numbers with two seals			Mass [kg]
	Normal	RT	Corrosion-resistant	
8	R0658 208 40	R0658 262 40	R0658 208 30	0.011
10	R0658 210 40	R0658 261 40	R0658 210 30	0.014
12	R0658 212 40	R0658 251 40	R0658 212 30	0.016
14	R0658 214 40	R0658 258 40	R0658 214 30	0.018
16	R0658 216 40	R0658 252 40	R0658 216 30	0,025
20	R0658 220 40	R0658 253 40	R0658 220 30	0.028
25	R0658 225 40	R0658 254 40	R0658 225 30	0.058
30	R0658 230 40	R0658 255 40	R0658 230 30	0.080
40	R0658 240 40	R0658 256 40	R0658 240 30	0.140
50	R0658 250 40	R0658 257 40	R0658 250 30	0.170

With one seal: R0658 1.. 40 oder R0658 1.. 30.



Shaft \varnothing d [mm]	Part Numbers Seals
12	R1331 812 10
16	R1331 816 10
20	R1331 820 10
25	R1331 825 10
30	R1331 830 10
40	R1331 840 10
50	R1331 850 10

The figures for dynamic load carrying capacity have been calculated assuming a nominal travel of 100,000 m.

For a nominal travel of 50,000 the "C" figures in the table must be multiplied by a factor of 1.26.

Dimensions

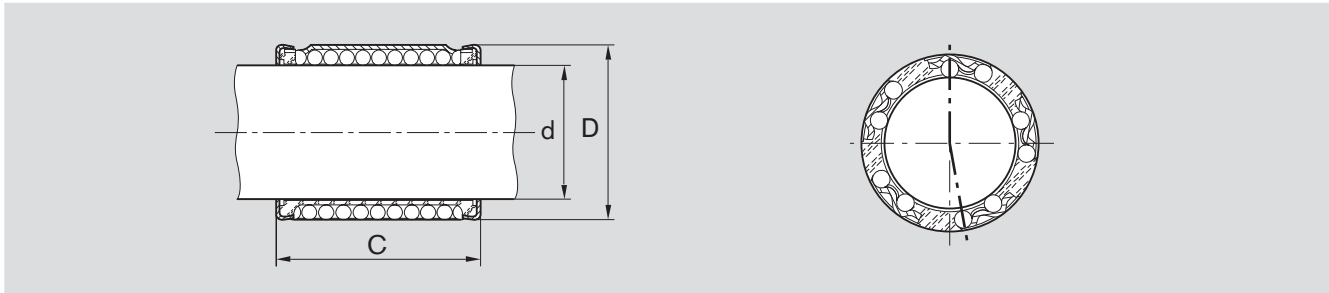

Dimensions [mm]			No. of Ball Circuits	Radial clearance [μm] Shaft/Bore normal ²⁾ , Corrosion-resistant ²⁾				Shaft/Bore RT (reduced radial clearance) h7/H7	Load Capacities [N]							
Ø d	D ¹⁾	C ±0.2		Corrosion-resistant ²⁾			dyn. C min		Normal		Corrosion-resistant					
				h7/H7	h7/JS7	h6/JS6			max	stat. C ₀ min	max	dyn. C min	max	stat. C ₀ min	max	
8	15	24	4	+29 +4	+20 -5	+13 -4	+9 -16	500	580	350	500	350	410	280	400	
10	17	26	5	+29 +4	+20 -5	+13 -4	+9 -16	600	720	410	600	420	500	330	480	
12	19	28	5	+37 +2	+26 -8	+19 -8	+13 -22	730	870	420	620	510	610	340	500	
14	21	28	5	+37 +2	+26 -8	+19 -8	+13 -22	760	900	430	630	530	630	340	500	
16	24	30	5	+37 +2	+26 -8	+19 -8	+13 -22	950	1120	500	730	660	780	400	580	
20	28	30	6	+38 +2	+28 -9	+20 -9	+14 -22	1120	1410	610	900	780	990	480	720	
25	35	40	6	+42 +2	+29 -10	+21 -10	+18 -22	2330	2930	1310	1950	1630	2050	1050	1560	
30	40	50	6	+42 +2	+29 -10	+21 -10	+18 -22	3060	3250	1880	2790	2140	2700	1510	2230	
40	52	60	6	+48 +2	+33 -13	+23 -12	+24 -22	5040	6380	3140	4650	3520	4470	2510	3720	
50	62	70	6	+48 +2	+33 -13	+23 -12	+24 -22	5680	7180	3610	5350	3970	5030	2890	4280	

¹⁾ Shafts Ø 8 and 10: The plastic sleeve is slightly oversized. For applications with vibrations i.e. higher acceleration, additional retention is necessary.

Shafts Ø 12 to 50: The outer diameter of the metal holding ring is slightly oversized.

No special retention elements are necessary (housing bore length ≥ C).

²⁾ Tolerance K7 or K6 permissible in light-metal alloy housing (slight preload possible).

Seals

Structural Design

- Metal case
- Seal made out of Elastomer

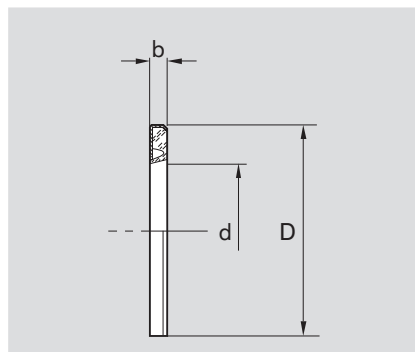

Ø d	Dimensions [mm]	
	D ³⁾	b
12	19	3
16	24	3
20	28	4
25	35	4
30	40	4
40	52	5
50	62	5

³⁾ The outer diameter D has been manufactured with an oversize of approx. 0.1 mm. No additional retention required.



Compact Linear Sets

Compact Linear Sets, R1027
closed, standard or corrosion-resistant

Compact Linear Sets, R1028
adjustable, standard

Structural Design

- Precision housing (aluminum)
- Compact Linear Bushing
- Two internal seals
- Lubricated with Dynalub 510



Shaft Ø d [mm]	Part numbers		Mass [kg]
	standard	corrosion-resistant ¹⁾	
12	R1027 212 44	R1027 212 34	0.08
16	R1027 216 44	R1027 216 34	0.11
20	R1027 220 44	R1027 220 34	0.15
25	R1027 225 44	R1027 225 34	0.27
30	R1027 230 44	R1027 230 34	0.40
40	R1027 240 44	R1027 240 34	0.75
50	R1027 250 44	R1027 250 34	1.20

¹⁾ Linear Bushing, corrosion-resistant (anti-friction bearing steel to ISO 683-17 / EN 10088)



Shaft Ø d [mm]	Part numbers	Mass [kg]
	standard	
12	R1028 212 44	0.08
16	R1028 216 44	0.11
20	R1028 220 44	0.15
25	R1028 225 44	0.27
30	R1028 230 44	0.40
40	R1028 240 44	0.75
50	R1028 250 44	1.20

Dimensions

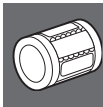
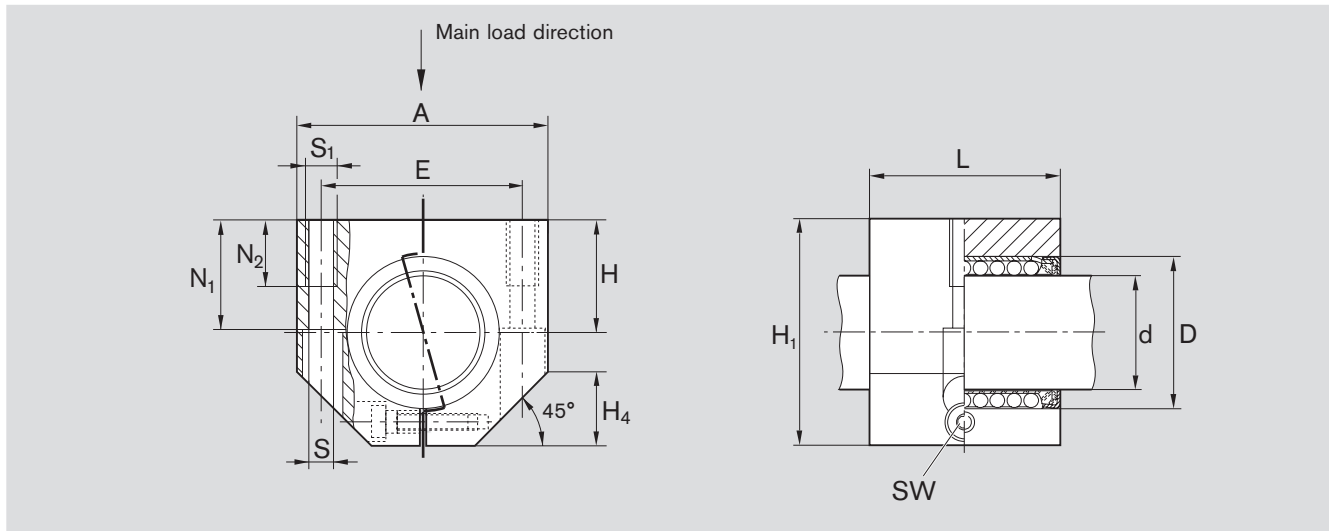

Dimensions [mm]												
Ø d	D	H	H ₁	A	L	E	S ¹⁾	S ₁	N ₁	N ₂	H ₄	SW
12	19	17	33	40	28	29	4.3	M5	16	11	11	2.5
16	24	19	38	45	30	34	4.3	M5	18	11	13	2.5
20	28	23	45	53	30	40	5.3	M6	22	13	15	3
25	35	27	54	62	40	48	6.6	M8	26	18	17	4
30	40	30	60	67	50	53	6.6	M8	29	18	19	4
40	52	39	76	87	60	69	8.4	M10	38	22	24	5
50	62	47	92	103	70	82	10.5	M12	46	26	30	6

Shaft Ø d [mm]	Radial clearance [µm]		Tolerance for H ²⁾ [µm]	Load capacity ³⁾ [N]			
	R1027 h6	R1028 h7		standard		Corrosion-resistant	
				dyn. C	stat. C ₀	dyn. C	stat. C ₀
12	+32 0	+37 +2	±12	810	490	570	390
16	+32 0	+37 +2	±12	1050	570	730	460
20	+33 -1	+38 +2	+13 -12	1410	900	990	720
25	+36 0	+42 +2	+13 -12	2930	1950	2050	1560
30	+36 0	+42 +2	+13 -12	3850	2790	2700	2230
40	+42 -1	+48 +2	+14 -12	6380	4650	4470	3720
50	+42 -1	+48 +2	+14 -12	7180	5350	5030	4280

Adjusted to zero-clearance on h5 shaft (lower limit) prior to delivery

¹⁾ Mounting screws to ISO 4762-8.8.
²⁾ Relative to shaft nominal dimension d.
³⁾ The load capacities stated are minimum values as the position and direction of load cannot always be precisely defined. If the loading direction is not the main load direction, multiply the capacity numbers by the following factors:
 Shafts-Ø 12 and 16: f = 0.90 f₀ = 0.86
 Shafts-Ø 20 and 50: f = 0.79 f₀ = 0.68

The figures for dynamic load carrying capacity have been calculated assuming a nominal travel of 100,000 m. For a nominal travel of 50,000 m, the "C" figures in the table must be multiplied by a factor of 1.26.

Compact Linear Sets

Compact Linear Sets, R1029
double
closed,
standard or corrosion-resistant

Structural design

- Precision housing, lightweight series (aluminum)
- Compact Linear Bushing
- Two internal seals
- Completely sealed
- Lubricated with Dynalub 510



Shaft Ø d [mm]	Part numbers		Mass [kg]
	standard	corrosion-resistant ¹⁾	
12	R1029 212 44	R1029 212 34	0.17
16	R1029 216 44	R1029 216 34	0.24
20	R1029 220 44	R1029 220 34	0.31
25	R1029 225 44	R1029 225 34	0.57
30	R1029 230 44	R1029 230 34	0.80
40	R1029 240 44	R1029 240 34	1.54
50	R1029 250 44	R1029 250 34	2.45

¹⁾ Linear Bushing, corrosion-resistant (anti-friction bearing steel to ISO 683-17 / EN 10088)

Dimensions

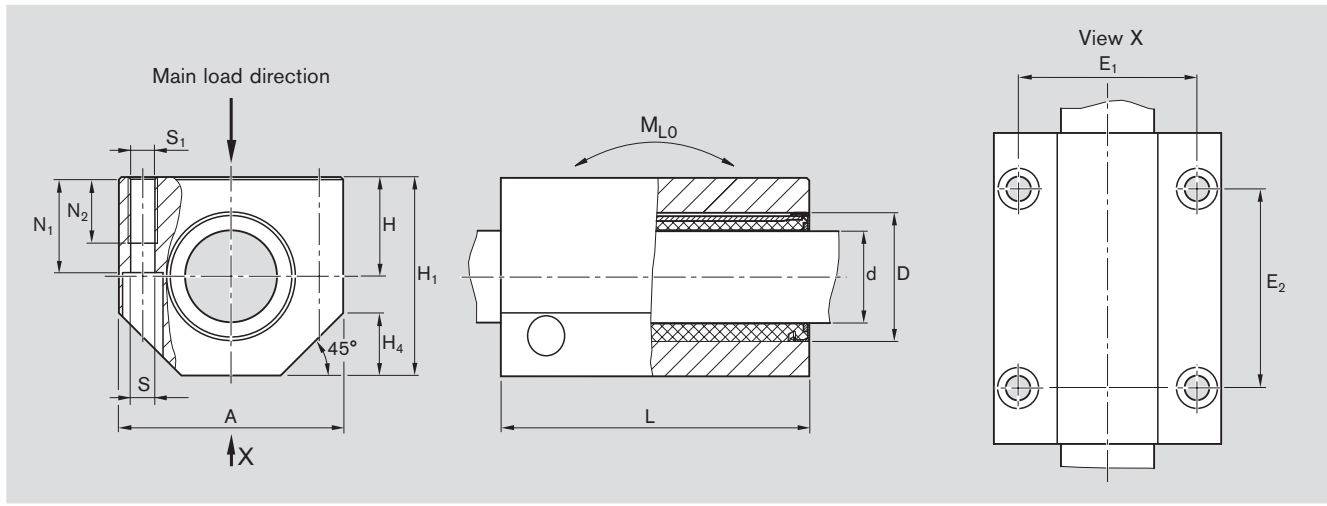

Ø d	D	H	H ₁	A	Dimensions [mm]				S ¹⁾	S ₁	N ₁	N ₂	H ₄
					L	E ₁ ±0.15	E ₂ ±0.15						
12	19	17	33	40	60	29	35	4.3	M5	16	11	11	
16	24	19	38	45	65	34	40	4.3	M5	18	11	13	
20	28	23	45	53	65	40	45	5.3	M6	22	13	15	
25	35	27	54	62	85	48	55	6.6	M8	26	18	17	
30	40	30	60	67	105	53	70	6.6	M8	29	18	19	
40	52	39	76	87	125	69	85	8.4	M10	38	22	24	
50	62	47	92	103	145	82	100	10.5	M12	46	26	30	

Shaft Ø d [mm]	Radial clearance [µm] Shaft		Tolerance for H ²⁾ [µm]	Load capacities ³⁾ [N]				Tipping moment [Nm] stat. M _{Lo}
	h6	h7		standard		corrosion-resistant		
				dyn. C	stat. C ₀	dyn. C	stat. C ₀	
12	+32 0	+37 +2	± 12	1310	980	920	780	13
16	+32 0	+37 +2	± 12	1700	1140	1180	920	18
20	+33 -1	+38 +2	+13 -12	2290	1800	1610	1440	21
25	+36 0	+42 +2	+13 -12	4760	3900	3330	3120	59
30	+36 0	+42 +2	+13 -12	6250	5580	4385	4460	103
40	+42 -1	+48 +2	+14 -12	10360	9300	7260	7440	204
50	+42 -1	+48 +2	+14 -12	11660	10700	8170	8560	271

¹⁾ Mounting screws to ISO 4762-8.8.

²⁾ Relative to shaft nominal dimension d.

³⁾ The load capacities stated are minimum values as the position and direction of load cannot always be precisely defined.

If the loading direction is not the main load direction, multiply the capacity numbers by the following factors:

Shafts-Ø 12 and 16: $f = 0.90$ $f_0 = 0.86$

Shafts-Ø 20 and 50: $f = 0.79$ $f_0 = 0.68$

The figures for dynamic load carrying capacity have been calculated assuming a nominal travel of 100,000 m. For a nominal travel of 50,000 m, the "C" figures in the table must be multiplied by a factor of 1.26.

Compact Linear Sets

Compact Linear Sets, R1707
closed, corrosion-resistant

Applications

- Due to their clean-design, Compact Linear Sets 1707 are particularly suited to the food, semiconductor, chemical and medical industries.

Structural Design

- Precision housing made out of rust and acid-resistant chrome nickel-steel
- Compact Linear Bushings corrosion-resistant¹⁾
- Two internal seals
- Completely sealed

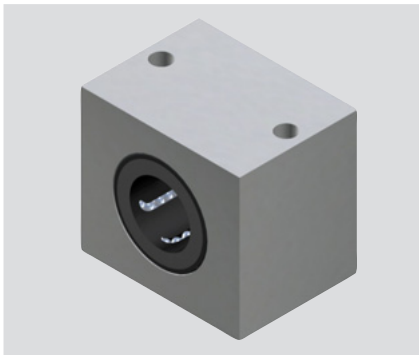

Shaft Ø d [mm]	Part Numbers	Mass [kg]
12	R1707 212 30	0.25
16	R1707 216 30	0.32
20	R1707 220 30	0.43
25	R1707 225 30	0.78
30	R1707 230 30	1.13
40	R1707 240 30	2.20

Lubricate Compact Linear Sets series R1707 properly before use.
For information and recommendations, see lubrication section.

For fitting corrosion-resistant shafts supports, see "Shaft Supports"

¹⁾ Anti-friction bearing steel to ISO 683-17 / EN 10088)

Dimensions

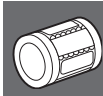
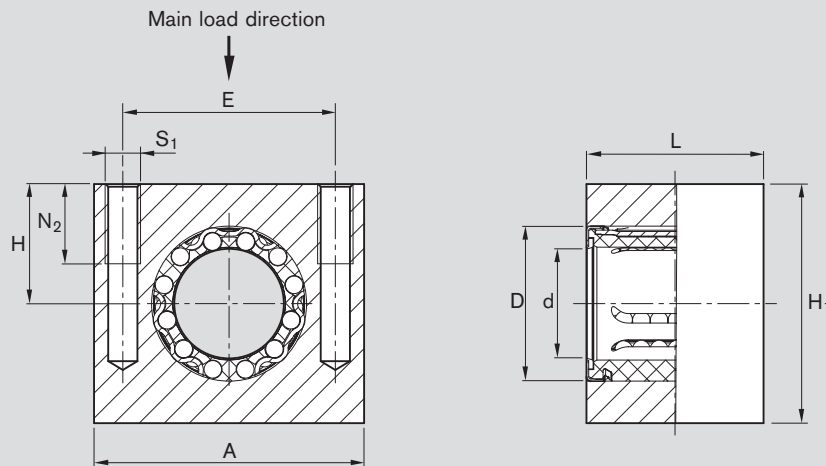

Dimensions [mm]									
$\varnothing d$	D	H	H_1	A	L	E	$S_1^{1)}$	N_2	
12	19	17	33	40	28	29	M5	11	± 0.15
16	24	19	38	45	30	34	M5	11	
20	28	23	45	53	30	40	M6	13	
25	35	27	54	62	40	48	M8	18	
30	40	30	60	67	50	53	M8	18	
40	52	39	76	87	60	69	M10	22	

Shaft $\varnothing d$ [mm]	Radial clearance [μm]		Tolerance for $H^{2)}$ [μm]	Load capacities ³⁾ [N]	
	h6	h7		dyn. C	stat. C_0
12	+32 0	+37 +2	± 12	570	390
16	+32 0	+37 +2	± 12	730	460
20	+33 -1	+38 +2	+13 -12	990	720
25	+36 0	+42 +2	+13 -12	2050	1560
30	+36 0	+42 +2	+13 -12	2700	2230
40	+42 -1	+48 +2	+14 -12	4470	3720

¹⁾ For a bore hole from "below" drill the bore through the core diameter

²⁾ Relative to shaft nominal dimension d

³⁾ The listed load capacities apply to the main load direction.

If the loading direction is not the main load direction, multiply the capacity numbers by the following factors:

Shafts- \varnothing 12 and 16: $f = 0.90$ $f_0 = 0.86$

Shafts- \varnothing 20 and 40: $f = 0.79$ $f_0 = 0.68$

The figures for dynamic load carrying capacity have been calculated assuming a nominal travel of 100,000 m. For a nominal travel of 50,000 m, the "C" figures in the table must be multiplied by a factor of 1.26.

Super Linear Bushings **A** and **B**

The Advantages

- The high-performance, great value, low-cost Linear Bushing
- Steel inserts with polished ball tracks and optimal bearing chamber for unbeatably quiet operation and long lifespan
- Super Linear Bushing **A** offers shaft deflection and self-alignment
- Super Linear Bushing **B** without self-alignment to transfer small tipping forces in the axis direction
- High travel speeds (to 5 m/s)
- Internal, external or without seals
- Open Linear Bushings on fully supported shafts for applications by which other linear guides would tend to deform due to inexact support structures
- Optional longitudinal seals for open Linear Bushings
- Linear sets with housings made of aluminum or cast iron



closed type (Super **A**)

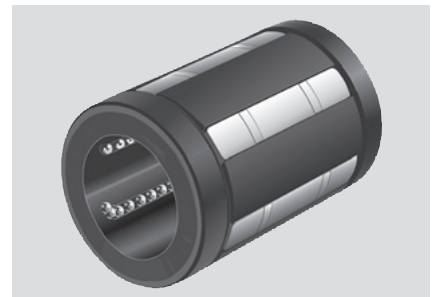

closed type (Super **B**)



open type (Super **A**)



open type (Super **B**)

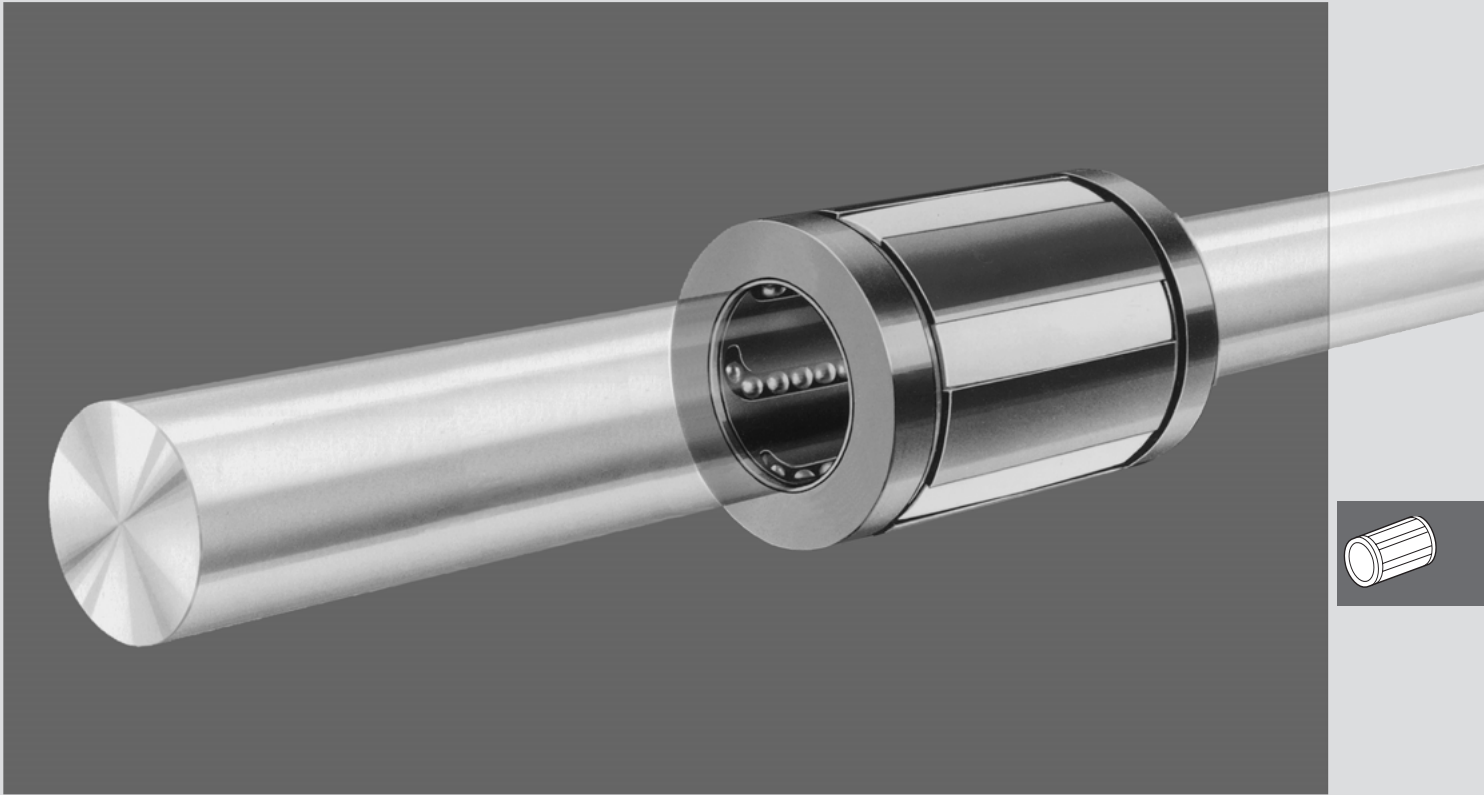

Super-Linear Bushings **A** und **B**

Technical Data

Please observe the general technical principles and mounting instructions at the beginning of this catalog as well as the additional technical data given below.

Sealing

Super Linear Bushings are available with internal or with separate wiper-type seals. The use of separate seals is advisable in applications involving a high risk of foreign-body contamination. In very dirty environments, additional sealing may be necessary (e.g. bellows-type dust boots or telescoping sleeves). Open type Super Linear Bushings can also be supplied fully sealed (with seal strip). It should be noted that the friction values for the fully sealed version will be higher.

Friction

Very low friction due to the rolling friction principle. Extremely low breakaway forces. The friction μ of unsealed Super Linear Bushings using oil as a lubricant lies between 0.001 and 0.0025. The friction is lowest under high load. It may, however, be greater than the stated value when only a slight load is applied. For Super Linear Bushings fitted at both ends with internal wiper seals and not subject to radial loading, the frictional drag (see table below) depends on the speed and the type of lubrication.

Shaft $\varnothing d$ [mm]	closed and open with internal seals		open completely sealed	
	Breakaway force ¹⁾ [N] approx.	Frictional drag ¹⁾ [N] approx.	Breakaway force [N] approx.	Frictional drag [N] approx.
10	1	0.5	–	–
12	1.5	0.8	6	3
16	2	1	9	4
20	3	1.5	10	5
25	4.5	2	14	6
30	6	2.5	18	8
40	8	3	24	10
50	10	4	30	12

¹⁾ For separate wiper seals, the values must be multiplied by a factor of 1.5.

Velocity

$$v_{\max}^{1)} = 3 \text{ m/s}$$

¹⁾ Velocities up to 5 m/s are possible, though the service life will be restricted due to the increased wear on the plastic parts. Units have been known to travel 50 to 100 x 10⁶ m without failure under test conditions.

Acceleration

$$a_{\max} = 150 \text{ m/s}^2$$

Operating Temperature

–20 °C to 100 °C

Direction of load and its influence on the load capacity of closed Super Linear Bushings

The stated load capacities are valid for installation in "min" position and should be taken as the basis for calculation.

In applications where the direction of load is exactly known and where the Super Linear Bushings can be mounted in the "max" position, the load capacity rating must be multiplied by the factors f_{max} (dynamic load capacity C) or f_{0max} (static load capacity C_0).

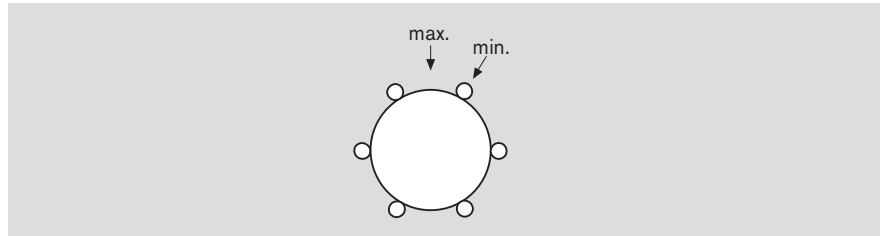

Direction of load and its influence on the load capacity of open Super Linear Bushings

The load capacities C and C_0 apply only when the load is acting along the line $\varrho = 0^\circ$. If the load is acting in any other direction, these load capacities must be multiplied by the factor f_ϱ (dynamic load capacity C) or $f_{\varrho 0}$ (static load capacity C_0).

A reduction in load capacity can be eliminated by selective circumferential positioning of the Super Linear Bushing (see Linear Set with Side Opening).

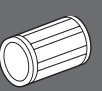

Load direction factors

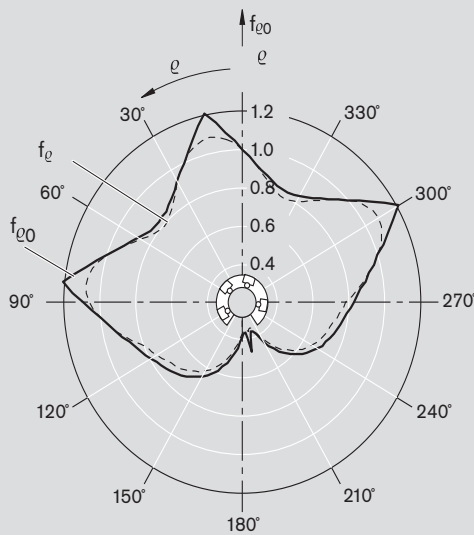

Shaft Ø d 12 and 16

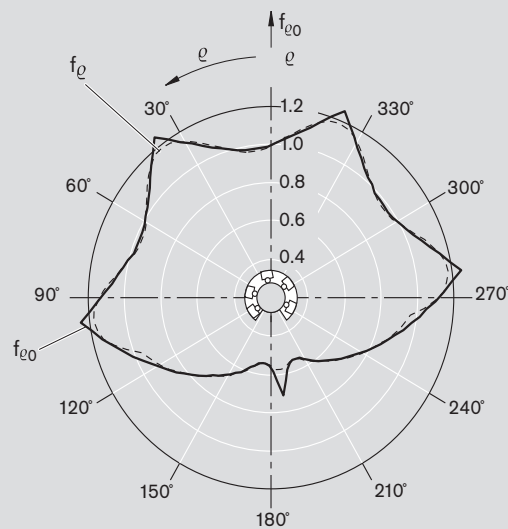

Shaft Ø d 20 to 50

Super-Linear Bushings **A** und **B**

Technical Data

Reduced load capacity with short-stroke applications

In short-stroke applications, the service life of the shafts is shorter than that of the Super Linear Bushings. For this reason, the load capacities C listed in the tables must be multiplied by the load factor f_w .

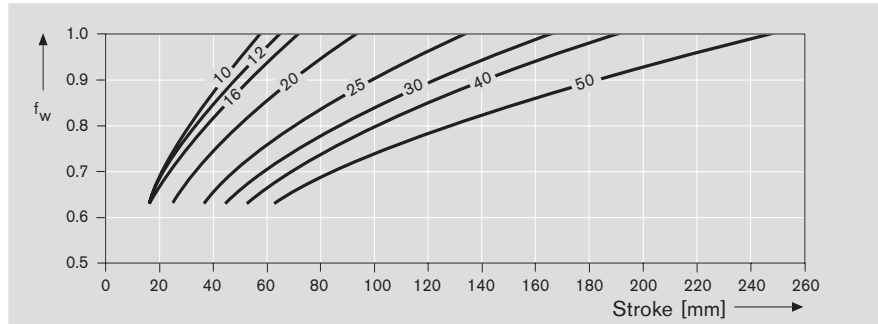

Reduced load capacity with high loads

If the load acting on Super Linear Bushing **A** is $F > 0.5 \times C$, there will be a reduction in the dynamic load capacity C.

Super Linear Bushing **A** self-alignment feature

The self-alignment feature together with the polished finish of the ball tracks result in extremely smooth operation. The running diagrams below show a comparison with a conventional linear bearing for a load of 800 N and an alignment error of about 8' (due to shaft deflection).

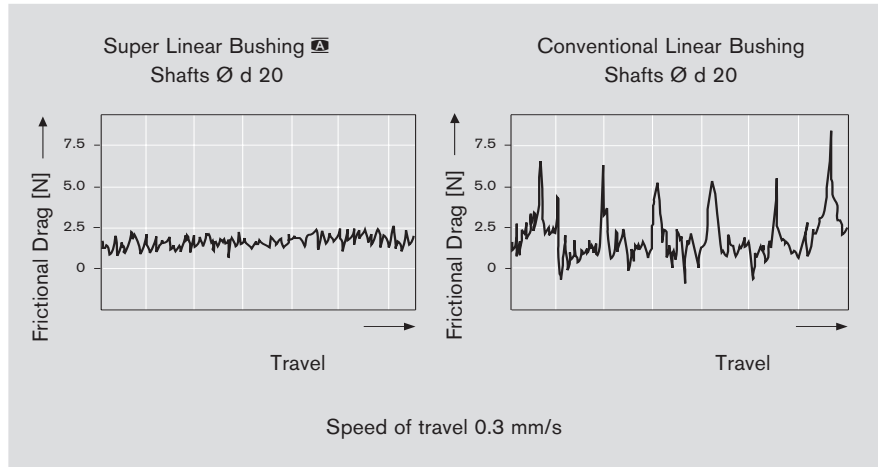
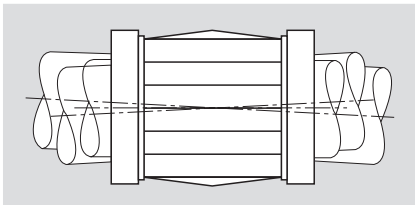

When this type is used, the self-alignment feature requires two Super Linear Bushings to be mounted on at least one of the two shafts of the assembly.

Operation under difficult conditions

For applications involving water-base coolants/lubricants, we recommend the use of the following linear bushing models:

- Super Linear Bushings **A** and **B**
- Standard Linear Bushings

In permanently humid or wet environments (water vapor, condensation), we recommend the use of the following corrosion-resistant linear bushing models:

- Segmental Linear Bushings,
- Compact Linear Bushings or
- Standard Linear Bushings

with steel parts made of corrosion-resistant steel to DIN 17230 / EN 10088.

Mounting Notes

Radial Clearance

The radial clearance values given in the tables have been obtained by statistical methods and are representative of the clearances to be expected in actual practice.

Adjusting the radial clearance

The radial clearance is adjustable in all types of Super Linear Bushings. If an application calls for zero clearance, the radial clearance must be reduced by means of an adjusting screw in the bushing housing (see also Linear Sets) until a slight resistance is felt when the shaft is turned. In applications subject to vibration, the adjusting screw should be suitably secured against working loose once the desired clearance has been established.

Preload

If negative clearance (preload) is required, we recommend that zero clearance should be established as described above using a dummy shaft whose diameter is smaller by the amount of the desired preload than the actual guide shaft on which the linear bushing is to run.

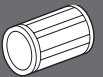

Super-Linear Bushings **A** und **B**

Custom-Built Housings

Tolerance recommendations for housing bore D:

- H7/JS7/JS6 Clearance, for all normal applications
 - K7/K6 Low clearance, for applications with shifting loads
 - M7/M6 Light preload, for applications with vibration and high acceleration.
- Please note the radial clearance (shaft/bore) values in the corresponding tables.

Lube nut und Lube port for Super Linear Bushings **A**, **B**, closed – with external seals

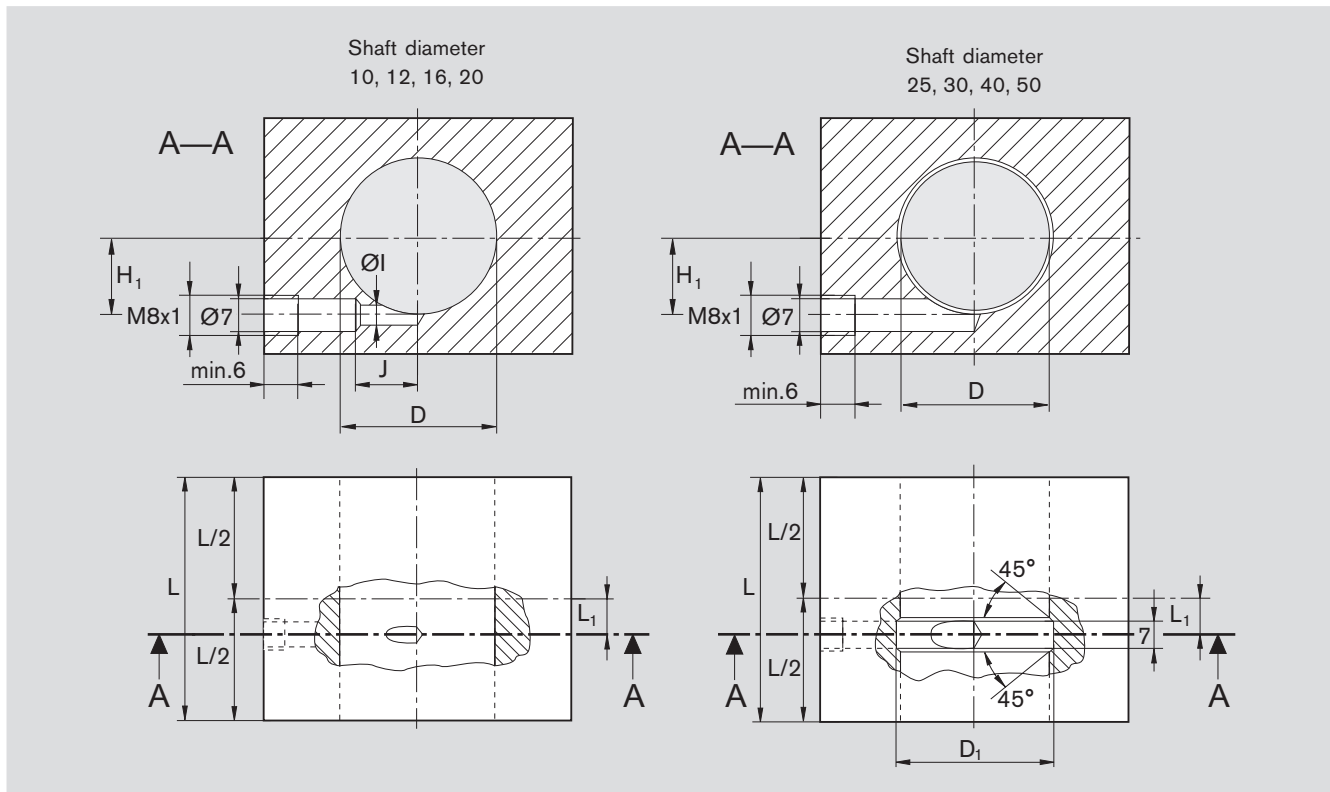

The lube channels shown in the illustration have been designed for grease lubricants.

Part numbers Super Linear Bushings		Seals	Shaft-diameter [mm] Ød	Lubricant quantities ¹⁾ [cm ³]		Dimensions [mm]						
A	B			Initial lubrication	Maintenance lubrication	L ₁	H ₁	L (min)	D	D ₁	ØI	J
R0670 010 00	R0672 010 00	R1331 610 00	10	1.3	0.4	7.5	6	36	19	-	3	11.5
R0670 012 00	R0672 012 00	R1331 612 00	12	1.6	0.5	9	8	39	22	-	5	13
R0670 016 00	R0672 016 00	R1331 616 00	16	1.6	0.5	10	12	43	26	-	5	18
R0670 020 00	R0672 020 00	R1331 620 00	20	3.5	1.1	13.5	15	54	32	-	2	15.5
R0670 025 00	R0672 025 00	R1331 625 00	25	5.5	1.7	18.5	20	67	40	42	-	-
R0670 030 00	R0672 030 00	R1331 630 00	30	8	2.4	23.5	23.5	79	47	49	-	-
R0670 040 00	R0672 040 00	R1331 640 00	40	14	4.2	27.5	31	91	62	66	-	-
R0670 050 00	R0672 050 00	R1331 650 00	50	24	7.2	34.5	37.5	113	75	79	-	-

¹⁾ Maximum fill volume for Rexroth Linear Bushings housing.

The shown fill volumes for the initial lubrication and maintenance lubrication apply to Linear sets R1035 / R1036.

custom-built housing with deviating grease nipple dimensions of the shaft diameter influences the fill volumes of the initial lubrication.

Lube nut and Lube port for Super Linear Bushings **A**, **B**, open – with external seals

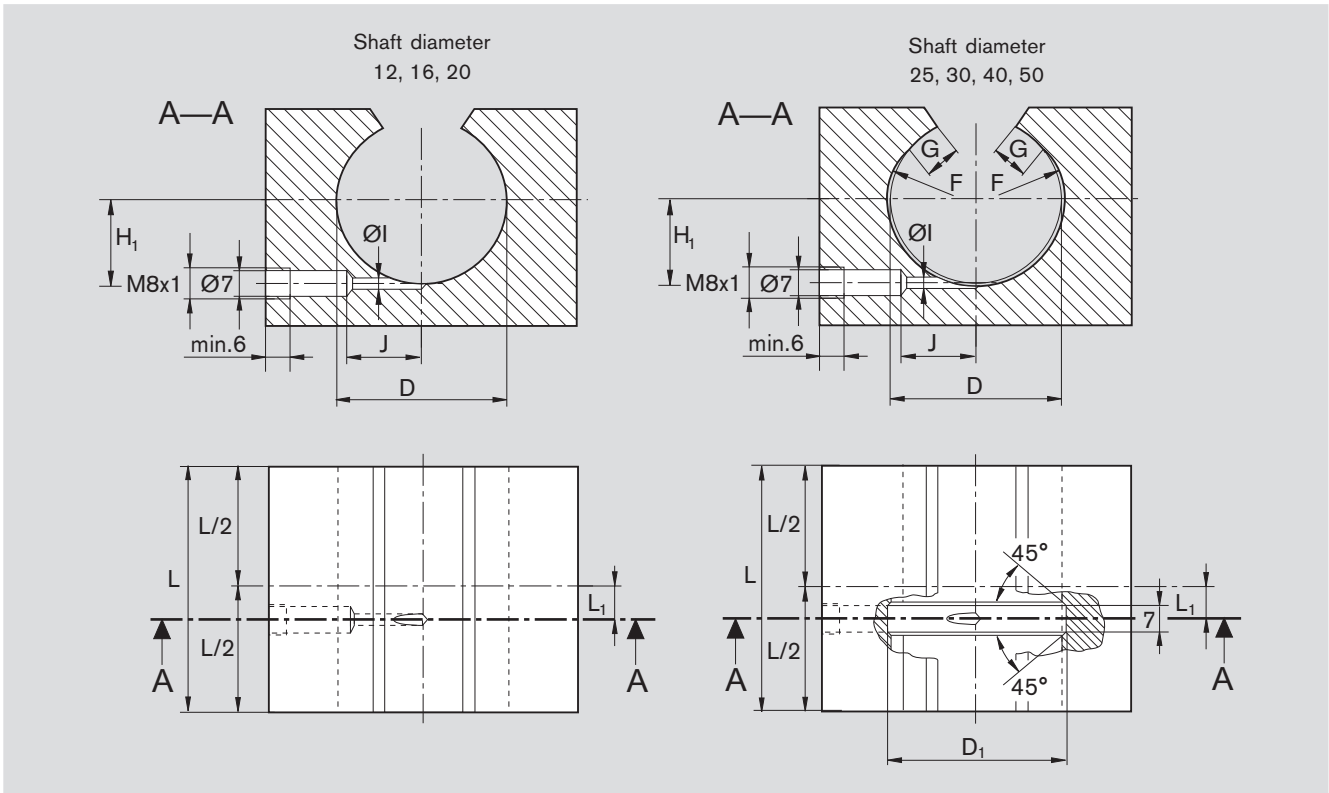
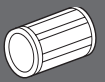

The lube channels shown in the illustration have been designed for grease lubricants. Seals must be secured axially.

Part numbers		Seals	Shaft-diameter [mm] Ød	Lubrication quantities ²⁾ [cm ³]		Dimensions [mm]								
A	B			Initial lubrication	Maintenance lubrication	L ₁	H ₁	L (min)	D	D ₁	F	G	ØI	J
R0671 012 00	R0673 012 00	R1331 712 50	12	1.3	0.4	9	8	39	22	-	-	-	2	13
R0671 016 00	R0673 016 00	R1331 716 50	16	1.3	0.4	10	12	43	26	-	-	-	2	14
R0671 020 00	R0673 020 00	R1331 720 50	20	3	0.9	13.5	15	54	32	-	-	-	2	16
R0671 025 00	R0673 025 00	R1331 725 50	25	5	1.5	18.5	20	67	40	42	R15	4	7	-
R0671 030 00	R0673 030 00	R1331 730 50	30	7	2.1	23.5	23.5	79	47	49	R18	4.5	7	-
R0671 040 00	R0673 040 00	R1331 740 50	40	13	3.9	27.5	31	91	62	66	R23	6	7	-
R0671 050 00	R0673 050 00	R1331 750 50	50	22	6.6	34.5	37.5	113	75	79	R28	7	4	30

²⁾ Maximum fill volume for Rexroth Linear Bushings in the housing

The shown fill volumes for the initial lubrication and maintenance lubrication apply to Linear sets R1037 / R1038.

custom-built housing with deviating grease nipple dimensions of the shaft diameter influences the fill volumes of the initial lubrication.

Super-Linear Bushings **A** und **B**

Custom-Built Housings - Retention

Super Linear Bushings closed

- Retaining rings
- Metal case
- Seal with metal case
- Specialty construction

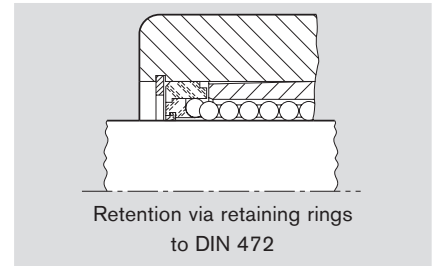
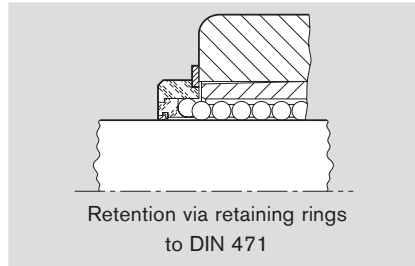

Shaft Ø d [mm]	Retaining rings DIN 471		Retaining rings DIN 472	
	Part numbers	Dimensions [mm]	Part numbers	Dimensions [mm]
10	R3410 763 00	19 x 1.2	R3410 221 00	19 x 1
12	R3410 714 00	22 x 1.2	R3410 209 00	22 x 1
16	R3410 715 00	27 x 1.2 ¹⁾	R3410 210 00	26 x 1.2
20	R3410 716 00	33 x 1.5 ¹⁾	R3410 211 00	32 x 1.2
25	R3410 717 00	42 x 1.75	R3410 212 00	40 x 1.75
30	R3410 718 00	48 x 1.75	R3410 213 00	47 x 1.75
40	R3410 719 00	62 x 2	R3410 214 00	62 x 2
50	R3410 720 00	75 x 2.5	R3410 215 00	75 x 2.5

¹⁾ Not to DIN 471.

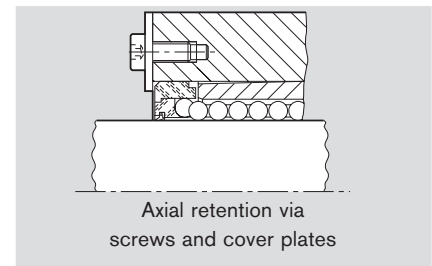
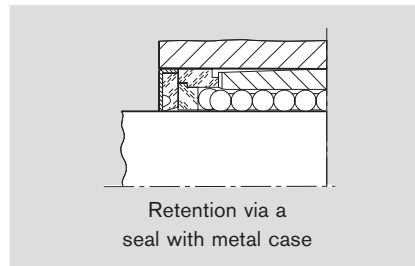
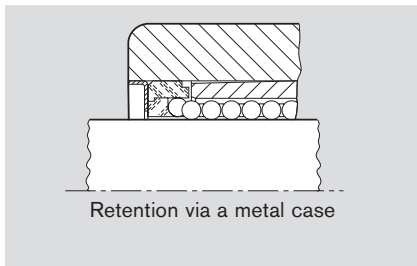

Seals closed

Materials:

- Metal case
- Elastomer seal

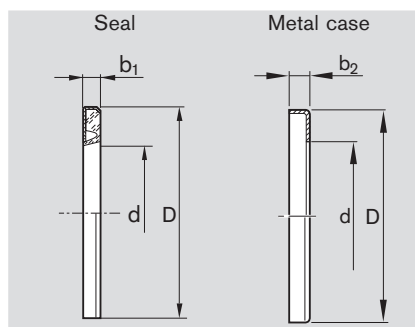
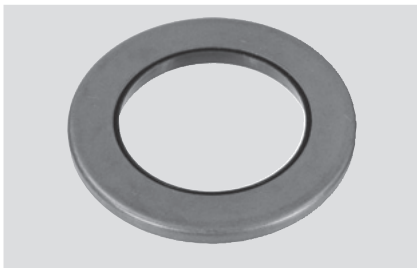

Metal case closed

Material: Steel

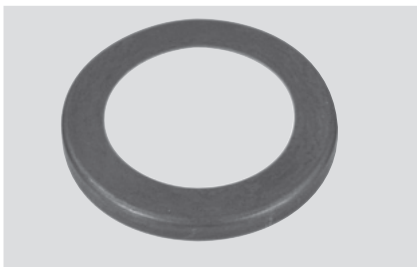

Shaft Ø d [mm]	Dimensions [mm]			Part numbers	
	D ¹⁾	b_1 +0.3	b_2 +0.5	Seals	Metal cases
10	19	3	3	R1331 610 00	R0901 184 00
12	22	3	3	R1331 612 00	R0901 074 00
16	26	3	3	R1331 616 00	R0901 075 00
20	32	4	4	R1331 620 00	R0901 076 00
25	40	4	4	R1331 625 00	R0901 077 00
30	47	5	5	R1331 630 00	R0901 078 00
40	62	5	5	R1331 640 00	R0901 079 00
50	75	6	6	R1331 650 00	R0901 115 00

¹⁾ The outside diameter D has been manufactured with an oversize of approximately 0.1 mm. No additional retention is required.

Super Linear Bushings open type

- axial and rotary retention by means of grooved taper pins

Notes for mounting:

Open-type Super Linear Bushings are delivered with a ready-made locating pin hole. This hole is marked with a  from shaft diameter 25 upwards.

The grooved locating pin must be driven in to the depth shown in the illustrations, as applicable, at the time of mounting.

The outer diameter of the Super Linear Bushing must then be reduced until the bushing can be slipped past the pin.

When the linear bushing is aligned in the housing bore, the taper pin will engage in the retaining hole.

Size of the hole through housing for grooved locating pin:

Shaft diameters 12 to 40:

Ø 3.0 H11

(Grooved pin ISO 8744-3x ...-St)

Shaft diameter 50:

Ø 5.0 H11

(Grooved pin ISO 8744-5x ...-SA)

Super Linear Bushings for shaft diameters 25 to 50 are provided with 2 locating pin holes.

The second locating pin hole (Ø 3.5 for shaft diameters 25,30 and 40, and Ø 4.5 for shaft diameter 50) is provided as an alternative means for retention of the Linear Bushing.

The original locating pin holes are marked with a star  (see illustration).

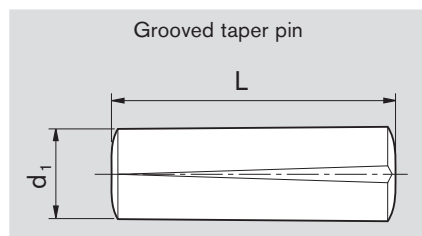
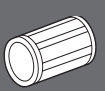
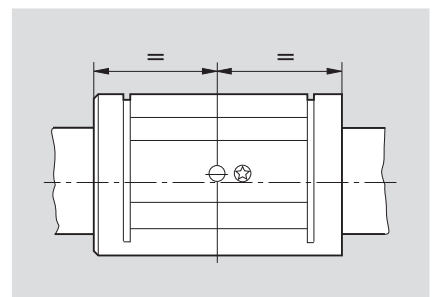
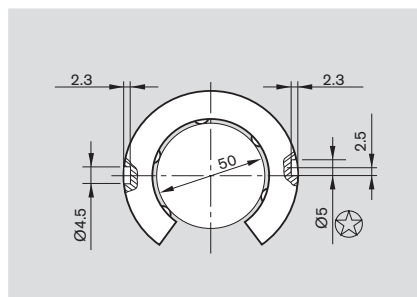
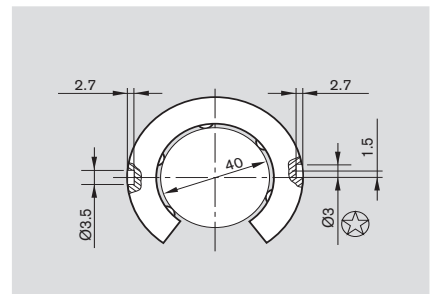
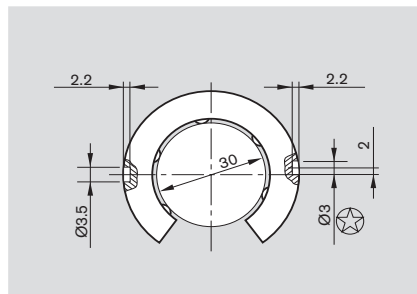
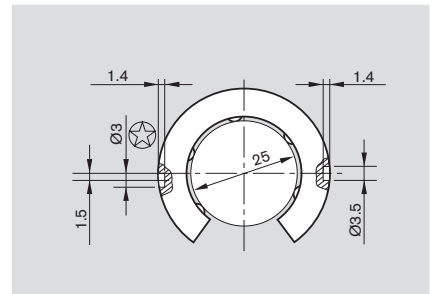
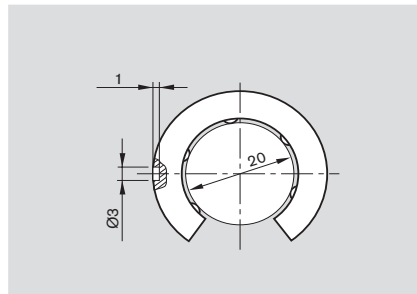
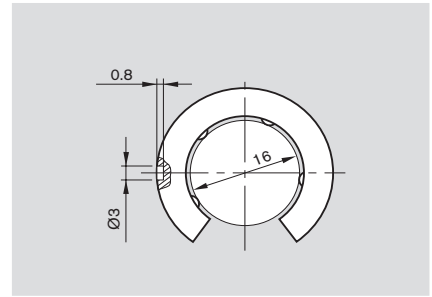
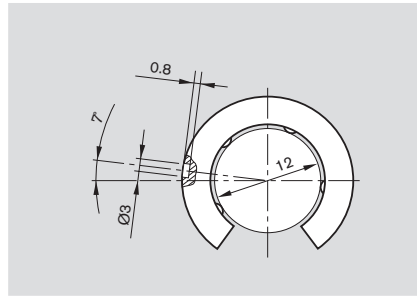

Shaft Ø d [mm]	Dimensions [mm]		Mounting hole for grooved taper pin [mm]	Part numbers
	d ₁	L		
12 ... 40	3	8.2	Ø 3 H11	R3425 013 00
	3	10.2		R3425 014 00
	3	14.2		R3425 015 00
50	5	20.4	Ø 5 H11	R3425 016 00
	5	14		R3425 017 00

Super-Linear Bushings **A** und **B**

Custom-Built Housings

- axial and rotary retention by means of locating screw

Points to note when mounting:
 Open type Standard Linear Bushings have been provided with the necessary retention hole. This hole is marked with a  from shaft diameter 25 upwards. On installation, the retention hole of the Linear Bushing must be aligned with the tapped hole in the housing. The screw is then inserted, screwed down to the specified depth and tightened to the specified torque.

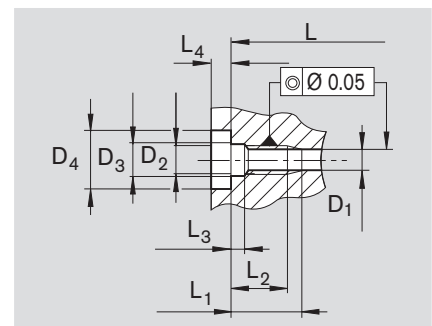
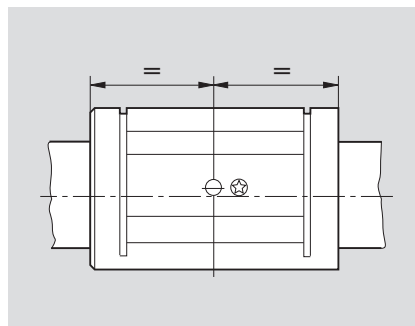
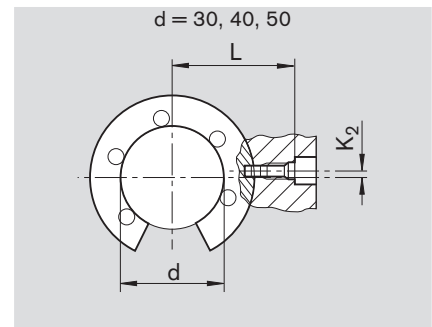
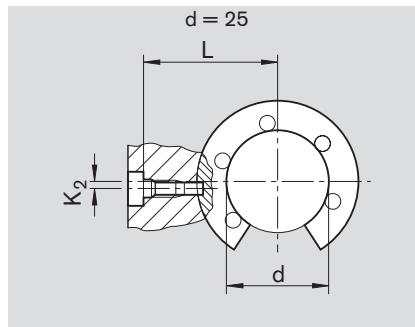
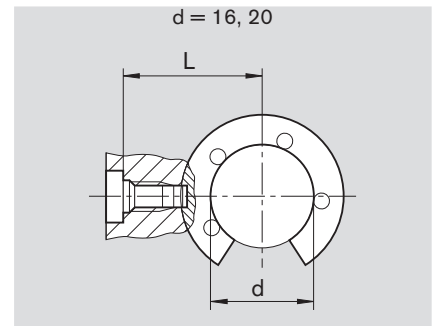
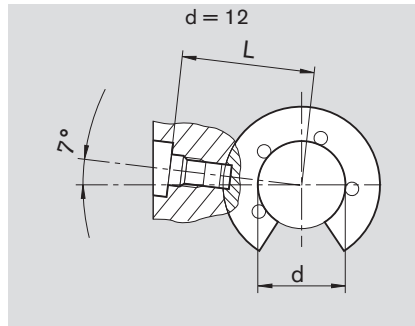

Locating screws

The locating screws are self-aligning.

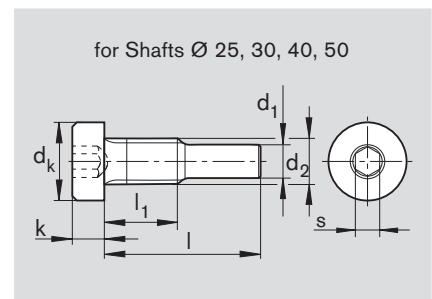
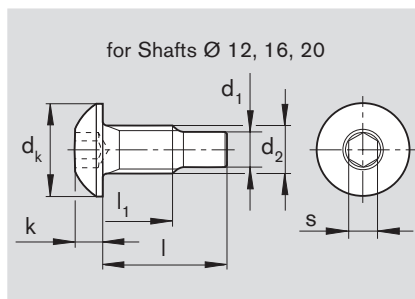

Shaft [mm] Ød	Dimensions [mm]																Locating screw		
	L	K ₂	L ₁	L ₂	L ₃	L ₄	D ₁	D ₂	D ₃	D ₄	d ₂	d _k	d ₁	l	l ₁	k	s	Part numbers	Tightening torque [Nm]
12	18.8 _{-0.1}	-	7.2 _{max}	5.2	1.3	2.5	3.1	M4	4.5	8	M4	7.6	3	8.45	4.5	2.2	2.5	R3429 008 01	1.9
16	22.5 _{-0.1}	0	8.5 ^{+0.2}	6.5	1.3	2.5	3.1	M4	4.5	8	M4	7.6	3	10.15	5.7	2.2	2.5	R3429 009 01	1.9
20	25.5 _{-0.1}	0	8.5 ^{+0.2}	6.5	1.3	2.5	3.1	M4	4.5	8	M4	7.6	3	10.15	5.7	2.2	2.5	R3429 009 01	1.9
25	33.05 _{-0.1}	1.5	10 ^{+0.2}	8	2	3.2	3.1	M4	4.5	8	M4	7	3	14.1	6.5	2.8	2.5	R3427 009 09	1.9
30	36 _{-0.15}	2	10 ^{+0.2}	8	2	3.2	3.1	M4	4.5	8	M4	7	3	14.1	6.5	2.8	2.5	R3427 009 09	1.9
40	42.9 _{-0.15}	1.5	10 ^{+0.2}	8	2	3.2	3.1	M4	4.5	8	M4	7	3	14.1	6.5	2.8	2.5	R3427 009 09	1.9
50	58.5 _{-0.2}	2.5	17.5 ^{+0.5}	13.5	3.7	6	5.1	M8	9	15	M8	13	5	22.8	12.5	5	5	R3427 005 09	16

Seals open

Materials:

- Metal case
- Elastomer seal

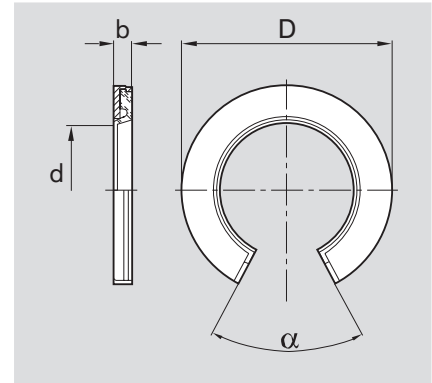

Shaft Ø d [mm]	Dimensions [mm]		Angle [°] $\alpha^{2)}$	Part numbers Seals
	D ¹⁾	b +0.1 -0.2		
12	22	3	66	R1331 712 50
16	26	3	68	R1331 716 50
20	32	4	55	R1331 720 50
25	40	4	57	R1331 725 50
30	47	5	57	R1331 730 50
40	62	5	56	R1331 740 50
50	75	6	54	R1331 750 50

¹⁾ Outside diameter D is about 0.3 mm oversized. No retaining elements required. Additional means of retention recommended for applications subject to vibration or high acceleration rates.

²⁾ Lower limit, measured when mounted in a bore of nominal diameter D.

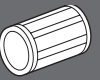

Super-Linear Bushings **A**

Super Linear Bushing **A** with Self-alignment

Super Linear Bushings, R0670 closed type

Super Linear Bushings, R0671 open type

Structural design

- Ball retainer with polyamide outer sleeve
- Hardened steel segmental load bearing plates with ground ball tracks
- Balls of anti-friction bearing steel
- Automatic compensation of alignment errors up to 30°
- Without seals
- With internal/separate seals

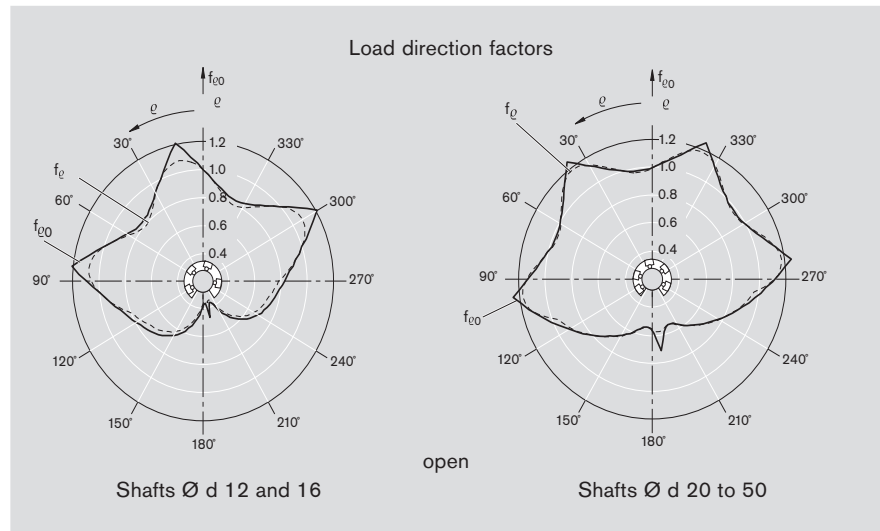

Shaft Ø d [mm]	Part numbers		Mass [kg]
	without seal	with two internal seals	
10	R0670 010 00	R0670 210 40	0.017
12	R0670 012 00	R0670 212 40	0.023
16	R0670 016 00	R0670 216 40	0.028
20	R0670 020 00	R0670 220 40	0.061
25	R0670 025 00	R0670 225 40	0.122
30	R0670 030 00	R0670 230 40	0.185
40	R0670 040 00	R0670 240 40	0.360
50	R0670 050 00	R0670 250 40	0.580

With one internal seal: R0670 1.. 40.



Shaft Ø d [mm]	without seal	Part numbers		Mass [kg]
		with two internal seals	with two internal seals and seal strip	
12	R0671 012 00	R0671 212 40	R0671 212 45	0.018
16	R0671 016 00	R0671 216 40	R0671 216 45	0.022
20	R0671 020 00	R0671 220 40	R0671 220 45	0.051
25	R0671 025 00	R0671 225 40	R0671 225 45	0.102
30	R0671 030 00	R0671 230 40	R0671 230 45	0.155
40	R0671 040 00	R0671 240 40	R0671 240 45	0.300
50	R0671 050 00	R0671 250 40	R0671 250 45	0.480

With internal seal: R0671 1.. 40.

For dimensions, see section "Custom-housing".

The figures for dynamic load-carrying capacity have been calculated assuming a nominal travel of 100,000 m. For a nominal travel of 50,000 m, the 'C' figures in the table must be multiplied by a factor of 1.26.

Dimensions

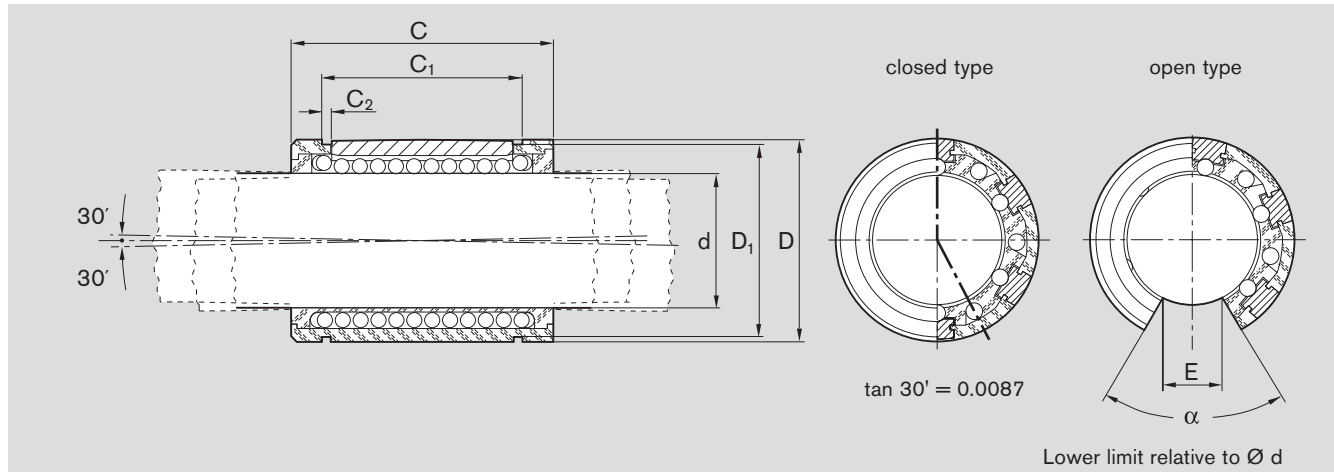

closed type

Ød	Dimensions [mm]					No. of ball circuits	Radial clearance [µm]						Load capacities [N]				
	D	C	C ₁	C ₂	D ₁		shaft/bore						dyn. C		stat. C ₀		
							h7/H7	h7/JS7	h6/JS6	h6/K6	h7/K7	h7/M7	h6/M6	min	max	min	max
10	19	29	21.6	1.3	18	5	+40 +11	+30 0	+23 +1	+18 -3	+25 -4	+19 -10	+12 -9	600	820	330	480
12	22	32	22.6	1.3	21	5	+43 +12	+33 +1	+25 +2	+21 -3	+28 -3	+22 -9	+15 -9	830	1140	420	620
16	26	36	24.6	1.3	24.9	5	+43 +12	+33 +1	+25 +2	+21 -3	+28 -3	+22 -9	+15 -9	1020	1400	530	780
20	32	45	31.2	1.6	30.5	6	+49 +13	+37 0	+28 +1	+23 -4	+29 -6	+24 -12	+16 -11	2020	2470	1050	1340
25	40	58	43.7	1.85	38.5	6	+49 +13	+37 0	+28 +1	+23 -4	+29 -6	+24 -12	+16 -11	3950	4820	2180	2790
30	47	68	51.7	1.85	44.5	6	+49 +13	+37 0	+28 +1	+23 -4	+29 -6	+24 -12	+16 -11	4800	5860	2790	3570
40	62	80	60.3	2.15	58.5	6	+57 +14	+42 -1	+31 +1	+25 -4	+30 -8	+27 -16	+16 -13	8240	10070	4350	5570
50	75	100	77.3	2.65	71.5	6	+57 +14	+42 -1	+31 +1	+25 -4	+30 -8	+27 -16	+16 -13	12060	14730	6470	8280

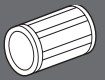

open

Ød	Dimensions [mm]						Angle α [°]	No. of ball circuits	Radial clearance [µm]						Load capacities ¹⁾ [N]		
	D	C	C ₁	C ₂	D ₁	E			shaft/bore						dyn. C	stat. C ₀	
									h7/H7	h7/JS7	h6/JS6	h6/K6	h7/K7	h7/M7			h6/M6
12	22	32	22.6	1.3	21	6.5	66	4	+43 +12	+33 +1	+25 +2	+21 -3	+28 -3	+22 -9	+15 -9	1060	510
16	26	36	24.6	1.3	24.9	9	68	4	+43 +12	+33 +1	+25 +2	+21 -3	+28 -3	+22 -9	+15 -9	1280	630
20	32	45	31.2	1.6	30.5	9	55	5	+49 +13	+37 0	+28 +1	+23 -4	+29 -6	+24 -12	+16 -11	2100	1070
25	40	58	43.7	1.85	38.5	11.5	57	5	+49 +13	+37 0	+28 +1	+23 -4	+29 -6	+24 -12	+16 -11	4130	2250
30	47	68	51.7	1.85	44.5	14	57	5	+49 +13	+37 0	+28 +1	+23 -4	+29 -6	+24 -12	+16 -11	5020	2880
40	62	80	60.3	2.15	58.5	19.5	56	5	+57 +14	+42 -1	+31 +1	+25 -4	+30 -8	+27 -16	+16 -13	8620	4480
50	75	100	77.3	2.65	71.5	22.5	54	5	+57 +14	+42 -1	+31 +1	+25 -4	+30 -8	+27 -16	+16 -13	12500	6620

¹⁾ The load capacities stated are minimum values as the position and direction of load cannot always be precisely defined α = 0°.

Super Linear Bushings **B**

Super Linear Bushing **B** without Self-alignment

Super Linear Bushings, R0672
closed type

Super Linear Bushings, R0673
open type

Structural design

- Ball retainer with polyamide outer sleeve
- Hardened steel segmental load bearing plates with ground ball tracks
- Balls of anti-friction bearing steel
- Without seals
- With internal/separate seals

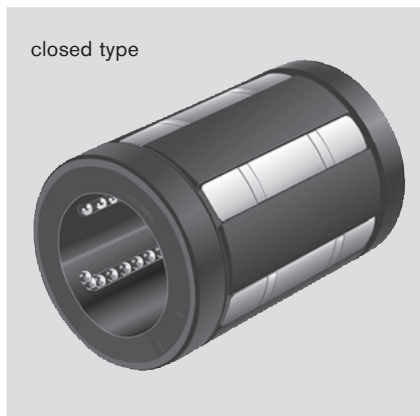
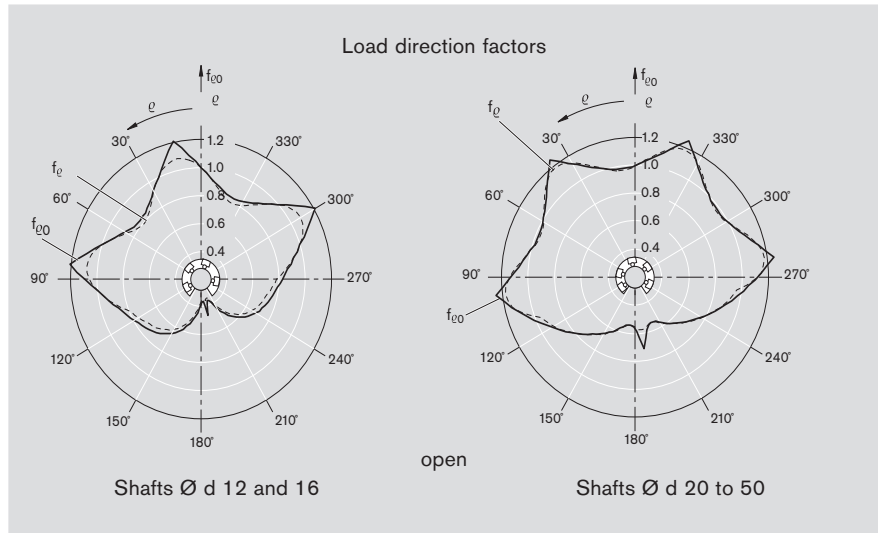

Shaft Ø d [mm]	Part numbers		Mass [kg]
	without seals	with two internal seals	
10	R0672 010 00	R0672 210 40	0.017
12	R0672 012 00	R0672 212 40	0.023
16	R0672 016 00	R0672 216 40	0.028
20	R0672 020 00	R0672 220 40	0.061
25	R0672 025 00	R0672 225 40	0.122
30	R0672 030 00	R0672 230 40	0.185
40	R0672 040 00	R0672 240 40	0.360
50	R0672 050 00	R0672 250 40	0.580

With one internal seal: R0672 1.. 40.



Shaft Ø d [mm]	Part numbers			Mass [kg]
	without seals	with two internal seals	with two internal seals and seal strip	
12	R0673 012 00	R0673 212 40	R0673 212 45	0.018
16	R0673 016 00	R0673 216 40	R0673 216 45	0.022
20	R0673 020 00	R0673 220 40	R0673 220 45	0.051
25	R0673 025 00	R0673 225 40	R0673 225 45	0.102
30	R0673 030 00	R0673 230 40	R0673 230 45	0.155
40	R0673 040 00	R0673 240 40	R0673 240 45	0.300
50	R0673 050 00	R0673 250 40	R0673 250 45	0.480

With one internal seal: R0673 1.. 40.

For dimensions, see section "Custom-housing".

The figures for dynamic load-carrying capacity have been calculated assuming a nominal travel of 100,000 m. For a nominal travel of 50,000 m, the 'C' figures in the table must be multiplied by a factor of 1.26.

Dimensions

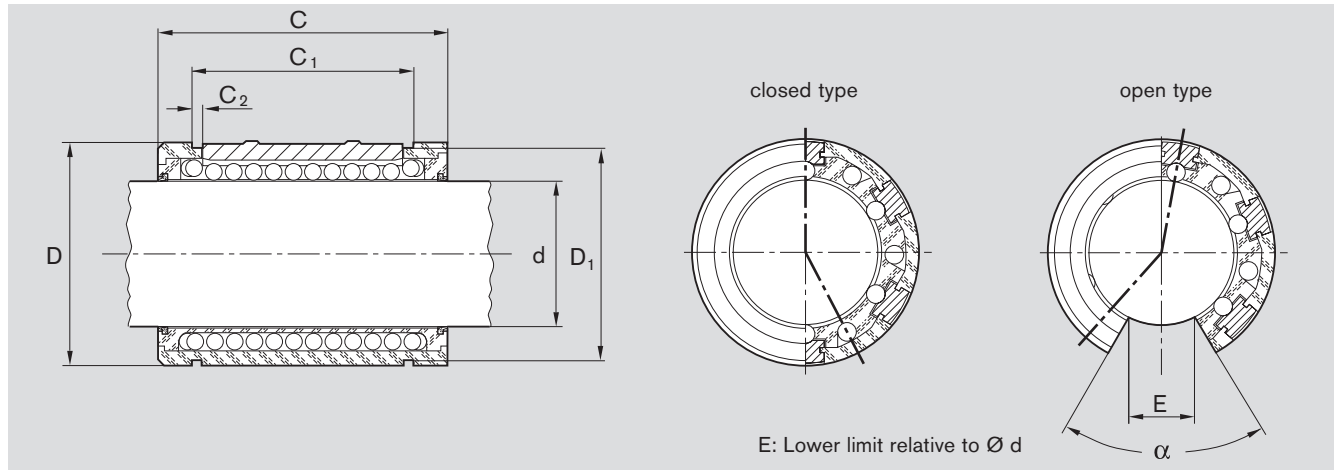

closed type

Ød	Dimensions [mm]					No. of ball circuits	Radial clearance [µm]								Load capacities [N]			
	D	C	C ₁	C ₂	D ₁		shaft/bore								dyn. C		stat. C ₀	
							h7/H7	h7/JS7	h6/JS6	h6/K6	h7/K7	h7/M7	h6/M6	min	max	min	max	
10	19	29	21.6	1.3	18	5	+40	+30	+23	+18	+25	+19	+12	600	820	330	480	
							+11	0	+1	-3	-4	-10	-9					
12	22	32	22.6	1.3	21	5	+43	+33	+25	+21	+28	+22	+15	830	1140	420	620	
							+12	+1	+2	-3	-3	-9	-9					
16	26	36	24.6	1.3	24.9	5	+43	+33	+25	+21	+28	+22	+15	1020	1400	530	780	
							+12	+1	+2	-3	-3	-9	-9					
20	32	45	31.2	1.6	30.5	6	+49	+37	+28	+23	+29	+24	+16	2020	2470	1050	1340	
							+13	0	+1	-4	-6	-12	-11					
25	40	58	43.7	1.85	38.5	6	+49	+37	+28	+23	+29	+24	+16	3950	4820	2180	2790	
							+13	0	+1	-4	-6	-12	-11					
30	47	68	51.7	1.85	44.5	6	+49	+37	+28	+23	+29	+24	+16	4800	5860	2790	3570	
							+13	0	+1	-4	-6	-12	-11					
40	62	80	60.3	2.15	58.5	6	+57	+42	+31	+25	+30	+27	+16	8240	10070	4350	5570	
							+14	-1	+1	-4	-8	-16	-13					
50	75	100	77.3	2.65	71.5	6	+57	+42	+31	+25	+30	+27	+16	12060	14730	6470	8280	
							+14	-1	+1	-4	-8	-16	-13					

open

Ød	Dimensions [mm]						Angle α [°]	No. of ball circuits	Radial clearance [µm]								Load capacities ¹⁾ [N]	
	D	C	C ₁	C ₂	D ₁	E			shaft/bore								dyn. C	stat. C ₀
									h7/H7	h7/JS7	h6/JS6	h6/K6	h7/K7	h7/M7	h6/M6			
12	22	32	22.6	1.3	21	6.5	66	4	+43	+33	+25	+21	+28	+22	+15	1060	510	
									+12	+1	+2	-3	-3	-9	-9			
16	26	36	24.6	1.3	24.9	9	68	4	+43	+33	+25	+21	+28	+22	+15	1280	630	
									+12	+1	+2	-3	-3	-9	-9			
20	32	45	31.2	1.6	30.5	9	55	5	+49	+37	+28	+23	+29	+24	+16	2100	1070	
									+13	0	+1	-4	-6	-12	-11			
25	40	58	43.7	1.85	38.5	11.5	57	5	+49	+37	+28	+23	+29	+24	+16	4130	2250	
									+13	0	+1	-4	-6	-12	-11			
30	47	68	51.7	1.85	44.5	14	57	5	+49	+37	+28	+23	+29	+24	+16	5020	2880	
									+13	0	+1	-4	-6	-12	-11			
40	62	80	60.3	2.15	58.5	19.5	56	5	+57	+42	+31	+25	+30	+27	+16	8620	4480	
									+14	-1	+1	-4	-8	-16	-13			
50	75	100	77.3	2.65	71.5	22.5	54	5	+57	+42	+31	+25	+30	+27	+16	12500	6620	
									+14	-1	+1	-4	-8	-16	-13			

¹⁾ The stated load capacities apply when the load is acting along the line α = 0°.

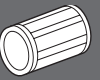

Linear Sets with Super Linear Bushings **A** or **E**

Overview

Linear Sets

Tandem Linear Sets

Closed type

For high-precision guidance with extreme ease of mounting. Version with fixed working bore diameter.

Adjustable type

For use when zero clearance or preload is required. The desired radial clearance is established by means of an adjusting screw. These Linear Sets are adjusted to zero clearance before delivery.

Open type

For long guideways when the shafts must be supported and high rigidity is required.

Open type, adjustable

For use when zero clearance or preload is required. The desired radial clearance is established by means of an adjusting screw. These Linear Sets are adjusted to zero clearance before delivery.

With side opening

Handles forces from all directions without reduction of load capacity.

With side opening, adjustable

For use when zero clearance or preload is required. The desired radial clearance is established by means of an adjusting screw. These Linear Sets are adjusted to zero clearance before delivery.

Flanged type

This element was developed as a complement to our Linear Set series for use in applications requiring the shaft to be arranged at right angles to the mounting base.

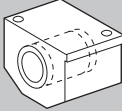
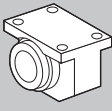
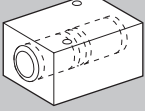
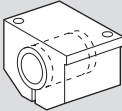
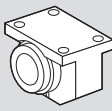
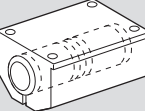
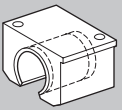
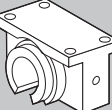
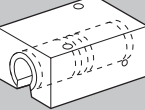
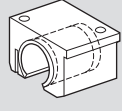
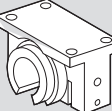
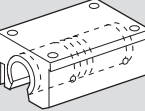
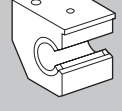
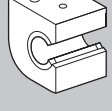
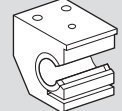
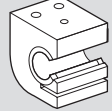
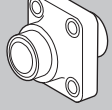
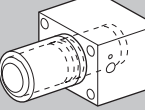
Linear Sets		Tandem Linear Sets
Super Linear Bushings A with self-alignment Super Linear Bushings E without self-alignment		Super Linear Bushings A with self-alignment
Aluminum housing	Cast iron housing	Aluminum housing
R1035 ... 	R1065 ... 	R1085 ... 
R1036 ... 	R1066 ... 	R1032 ... 
R1037 ... 	R1067 ... 	R1087 ... 
R1038 ... 	R1068 ... 	R1034 ... 
R1071 ... 	R1073 ... 	
R1072 ... 	R1074 ... 	
	R1081 ... 	R1083 ... 

Advantages/Mounting Instructions

Advantages

High load capacity and rigidity

These Linear Sets afford high rigidity irrespective of the direction of load action and even when their high load-carrying capacities are utilized to the full.

Compact block design and ease of mounting in the aluminum version

The Super Linear Bushing is completely enclosed in the compact housing to protect it against all external impacts.

Tapped through-holes make it possible to insert the screws from above or below. A fitting edge along the block facilitates lining up during installation and prevents misalignment of the assembly. Center-bores are provided for the user to drill locating pin holes for extra stability.

High precision and reliability

The housing design and the integral Super Linear Bushing ensure high precision and functional reliability.

Zero-clearance

The adjustable versions can be used to achieve zero-clearance assemblies.

Operating temperatures

-20 °C to 100 °C.

Mounting Instructions

Radial clearance

The radial clearance values given in the tables have been obtained by statistical methods and are representative of the values to be expected in actual practice. Adjustable types of Linear Sets are adjusted to zero clearance (when screwed down) on a shaft of diameter accurate to a tolerance of h5 (lower limit) before leaving the factory.

Vertical dimensions

The tables for Linear Sets contain tolerance values for the height dimension 'H'. These tolerance values have been obtained by statistical methods and are representative of the values to be expected in actual practice.

Screws

We recommend screws to ISO 4762-8.8 for mounting Linear Sets.

Lubrication

Whether grease is being applied for the first time or in-service, the shaft must always be inserted in the bushing. Add grease until the lubricant emerges.

Notes on mounting of Linear Sets with side opening

Without fitting edge

Align first shaft mounted on shaft support rail and screw down support rail.

- Align second shaft to ensure parallelism and screw down support rail.
- Push Linear Sets onto shafts and screw down on the machine table.

With fitting edge

- Push first shaft mounted on shaft support rail into contact with fitting edge and screw down support rail.
- Align second shaft to ensure parallelism and screw down support rail.
- Push Linear Sets onto the shafts.

Further assembly:

a) With two fitting edges (one on machine base and one on table): Push the Linear Sets on the first shaft into contact with the fitting edge on the machine table and screw down. Screw down the Linear Sets on the second shaft to the machine table.

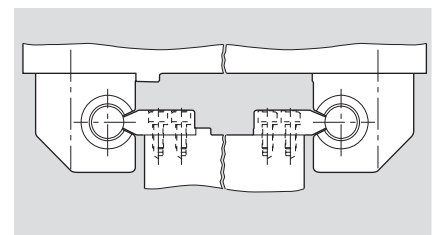
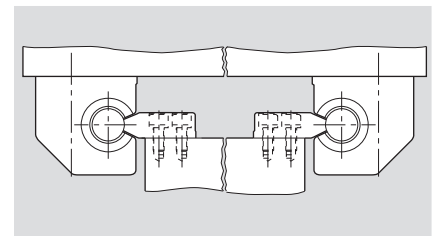

b) With only one fitting edge (on the machine base): Screw Linear Sets down to the machine table.

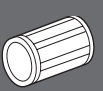

Linear-Sets wit Super Linear Bushings **A** or **B**, Aluminum housing

Linear Sets, R1035
closed type

Linear Sets, R1036
adjustable type

Structural design

- Precision housing, lightweight series (Aluminum)
- Super Linear Bushing with or without self-alignment
- External seals
- Fully sealed
- Easy re-lubrication



Shaft Ø d [mm]	Part numbers		Mass [kg]
	with Super Linear Bushing A easy re-lubrication with two seals	with Super Linear Bushing B easy re-lubrication with two seals	
10	R1035 610 20	R1035 810 20	0.10
12	R1035 612 20	R1035 812 20	0.13
16	R1035 616 20	R1035 816 20	0.20
20	R1035 620 20	R1035 820 20	0.34
25	R1035 625 20	R1035 825 20	0.65
30	R1035 630 20	R1035 830 20	0.97
40	R1035 640 20	R1035 840 20	1.80
50	R1035 650 20	R1035 850 20	3.00

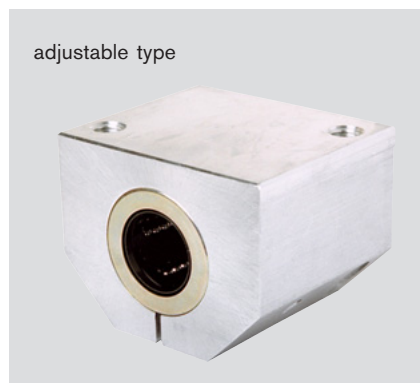

Shaft Ø d [mm]	Part numbers		Mass [kg]
	with Super Linear Bushing A easy re-lubrication with two seals	with Super Linear Bushing B easy re-lubrication with two seals	
10	R1036 610 20	R1036 810 20	0.10
12	R1036 612 20	R1036 812 20	0.13
16	R1036 616 20	R1036 816 20	0.20
20	R1036 620 20	R1036 820 20	0.34
25	R1036 625 20	R1036 825 20	0.65
30	R1036 630 20	R1036 830 20	0.97
40	R1036 640 20	R1036 840 20	1.80
50	R1036 650 20	R1036 850 20	3.00

Dimensions

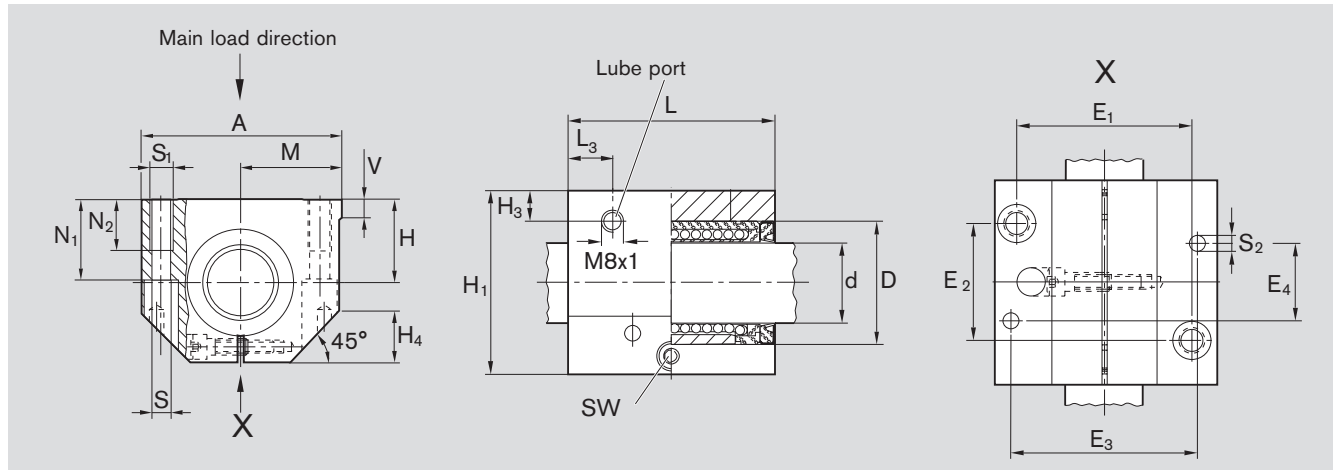

Dimensions [mm]																				
Ø d	D	H ¹⁾	H ₁	M ¹⁾	A	L	E ₁	E ₂	E ₃	E ₄	S ²⁾	S ₁	S ₂ ³⁾	N ₁	N ₂	H ₃	L ₃	V	SW	H ₄
		+0.008 -0.016		±0.01																
10	19		16	20	40	36	29±0.15	20±0.15	31	29	4.3	M5	4	15	11	10	10.5	5	2.5	10
12	22		18	21.5	43	39	32±0.15	23±0.15	34	32	4.3	M5	4	16.5	11	10	10.5	5	2.5	10
16	26		22	26.5	53	43	40±0.15	26±0.15	42	35	5.3	M6	4	21	13	10	11.5	5	3	13
20	32		25	30	60	54	45±0.15	32±0.15	50	45	6.6	M8	5	24	18	10	13.5	5	4	16
25	40		30	39	78	67	60±0.15	40±0.15	64	20	8.4	M10	6	29	22	10	15	6.5	5	20
30	47		35	43.5	87	79	68±0.15	45±0.15	72	30	8.4	M10	6	34	22	11.5	16	8	5	22
40	62		45	54	108	91	86±0.15	58±0.15	90	35	10.5	M12	8	44	26	14	18	10	6	28
50	75		50	66	132	113	108±0.20	50±0.20	108	42	13.5	M16	10	49	34	12.5	22	12	8	37

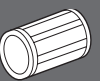

Shaft Ø d [mm]	Radial clearance [µm]		Load capacities ⁴⁾ [N] dyn. C stat. C ₀
	R1035 Shaft h6	R1036 h7	
10	+36 +9	+40 +11	730 380
12	+38 +10	+43 +12	1020 490
16	+38 +10	+43 +12	1250 620
20	+43 +11	+49 +13	2470 1340
25	+43 +11	+49 +13	4820 2790
30	+43 +11	+49 +13	5860 3570
40	+50 +12	+57 +14	10070 5570
50	+50 +12	+57 +14	14730 8280

Adjusted to zero-clearance on h5 shaft prior to delivery (lower limit) when screwed down

- ¹⁾ When screwed down, relative to shaft nominal dimension d.
- ²⁾ Mounting screws to ISO 4762-8.8.
- ³⁾ Center bores for locating pin holes
- ⁴⁾ The given load capacities are valid for the main load direction.
If the load direction is not the main load direction, the load capacities are to be multiplied by the following factors:
Shafts Ø 10 to 16: f = 0.82 f₀ = 0.86
Shafts Ø 20 to 50: f = 0.82 f₀ = 0.78

The figures for dynamic load-carrying capacity have been calculated assuming a nominal travel of 100,000 m. For a nominal travel of 50,000 m, the 'C' figures in the table must be multiplied by a factor of 1.26.

Linear Sets with Super Linear Bushings **A** or **B**, Aluminum housing

Linear Sets, R1037
open type

Linear Sets, R1038
open type, adjustable

Structural design

- Precision housing, lightweight series (Aluminum)
- Retention by means of a grooved taper pin
- Super Linear Bushing with or without self-alignment feature
- External seals
- Easy re-lubrication

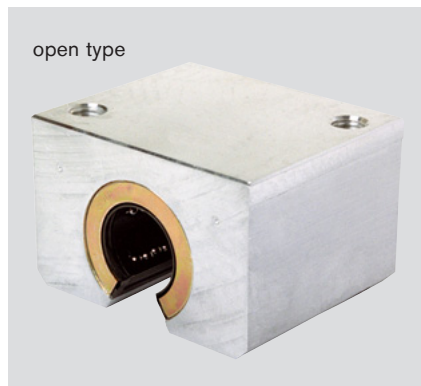
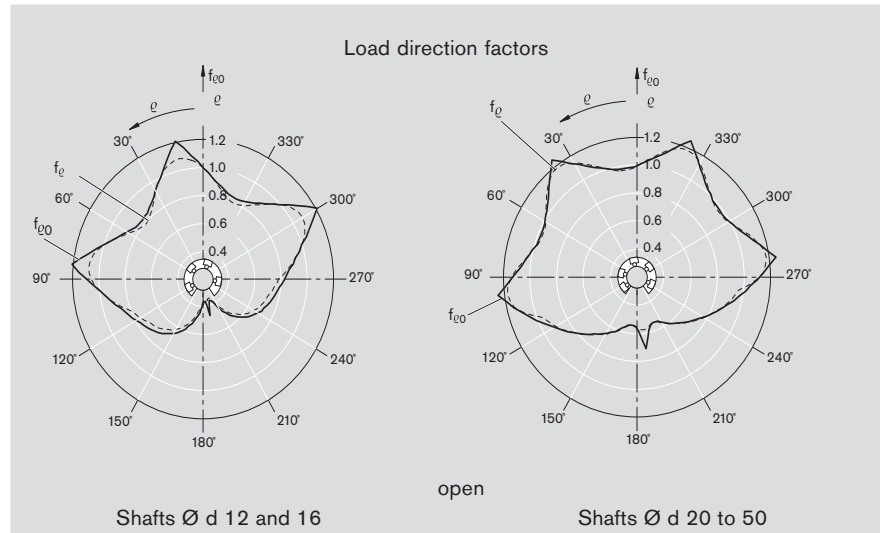

Shaft Ø d [mm]	Part numbers		Mass [kg]
	with Super Linear Bushing A easy re-lubrication with two seals	with Super Linear Bushing B easy re-lubrication with two seals	
12	R1037 612 20	R1037 812 20	0.11
16	R1037 616 20	R1037 816 20	0.17
20	R1037 620 20	R1037 820 20	0.30
25	R1037 625 20	R1037 825 20	0.57
30	R1037 630 20	R1037 830 20	0.86
40	R1037 640 20	R1037 840 20	1.60
50	R1037 650 20	R1037 850 20	2.60



Shaft Ø d [mm]	Part numbers		Mass [kg]
	with Super Linear Bushing A easy re-lubrication with two seals	with Super Linear Bushing B easy re-lubrication with two seals	
12	R1038 612 20	R1038 812 20	0.11
16	R1038 616 20	R1038 816 20	0.17
20	R1038 620 20	R1038 820 20	0.30
25	R1038 625 20	R1038 825 20	0.57
30	R1038 630 20	R1038 830 20	0.86
40	R1038 640 20	R1038 840 20	1.60
50	R1038 650 20	R1038 850 20	2.60

Dimensions

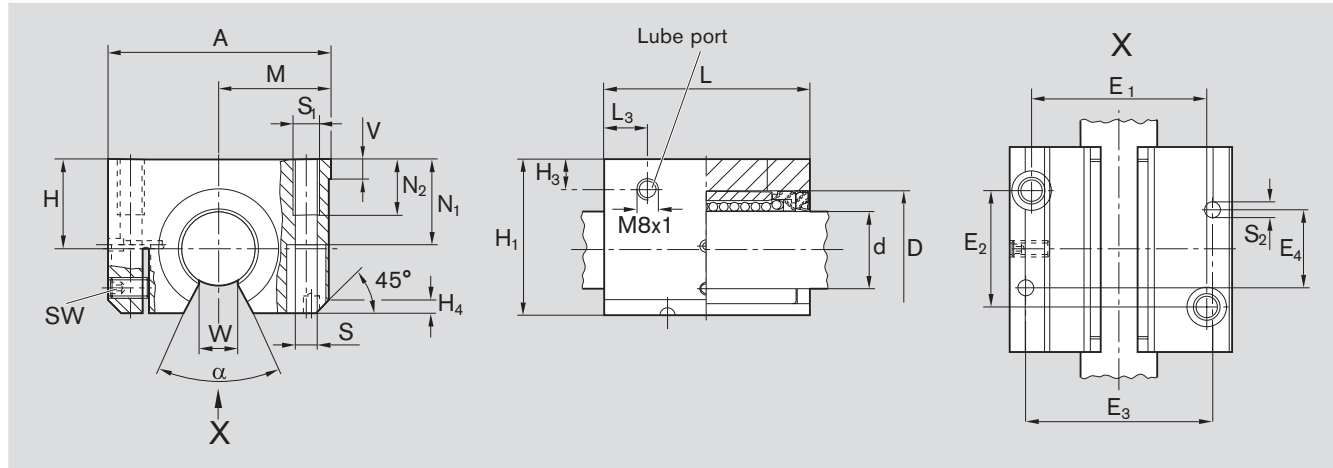

		Dimensions [mm]																			
Ø d	D	H ²⁾	H ₁	M ²⁾	A	L	E ₁	E ₂	E ₃	E ₄	S ³⁾	S ₁	S ₂ ⁴⁾	N ₁	N ₂	H ₃	L ₃	V	SW	W ⁵⁾	H ₄
12	22	+0.008 -0.016	18	21.5	43	39	32±0.15	23±0.15	34	32	4.3	M5	4	16.5	11	10	10.5	5	2.5	6.5	1.5
16	26		22	26.5	53	43	40±0.15	26±0.15	42	35	5.3	M6	4	21	13	10	11.5	5	2.5	9	2.5
20	32		25	30	60	54	45±0.15	32±0.15	50	45	6.6	M8	5	24	18	10	13.5	5	2.5	9	3.5
25	40		30	39	78	67	60±0.15	40±0.15	64	20	8.4	M10	6	29	22	10	15	6.5	3	11.5	4
30 ¹⁾	47		35	43.5	87	79	68±0.15	45±0.15	72	30	8.4	M10	6	34	22	11.5	16	8	3	14	6
40 ¹⁾	62		45	54	108	91	86±0.15	58±0.15	90	35	10.5	M12	8	44	26	14	18	10	4	19.5	6
50 ¹⁾	75		50	66	132	113	108±0.20	50±0.20	108	42	13.5	M16	10	49	34	12.5	22	12	5	22.5	6

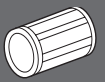

Shaft Ø d [mm]	Angle α [°]	Radial clearance ⁶⁾ [µm]		Load capacities ⁷⁾ [N]	
		R1037 Shaft h6	R1038 h7	dyn. C	stat. C ₀
12	66	+28 -1	+33 +1	1060	510
16	68	+28 -1	+33 +1	1280	630
20	55	+31 -2	+37 0	2100	1070
25	57	+31 -2	+37 0	4130	2250
30 ¹⁾	57	+31 -2	+37 0	5020	2880
40 ¹⁾	56	+35 -3	+42 -1	8620	4480
50 ¹⁾	54	+35 -3	+42 -1	12500	6620

Adjusted to zero clearance on h5 shaft prior to delivery (lower limit) when screwed down

- ¹⁾ In these sizes, the locating screw is on the opposite side to that shown in the illustration.
- ²⁾ When screwed down, relative to shaft nominal dimension d.
- ³⁾ Mounting screws to ISO 4762-8.8
- ⁴⁾ Center-bores for locating pin holes
- ⁵⁾ Minimum dimension based on shaft diameter d.
- ⁶⁾ When screwed down.
- ⁷⁾ The load capacities apply when the load is acting along the line $\varrho = 0^\circ$.

The figures for dynamic load-carrying capacity have been calculated assuming a nominal travel of 100,000 m. For a nominal travel of 50,000 m, the 'C' figures in the table must be multiplied by a factor of 1.26.

Linear Sets with Super Linear Bushings **A** or **B**, Aluminum housing

Linear Sets, R1071
with side opening

Linear Sets, R1072
with side opening, adjustable

Structural design

- Precision housing, lightweight series (aluminum)
- Retention by means of grooved taper pin
- Super Linear Bushing with or without self-alignment feature
- External seals
- Easy re-lubrication

The load carrying capacity of open linear bushings is considerably reduced when the load is applied to the "open" portion of the bushing. The Linear Set with Side Opening, lightweight series, has been developed to overcome this disadvantage and to permit selective circumferential positioning of the open linear bushing.

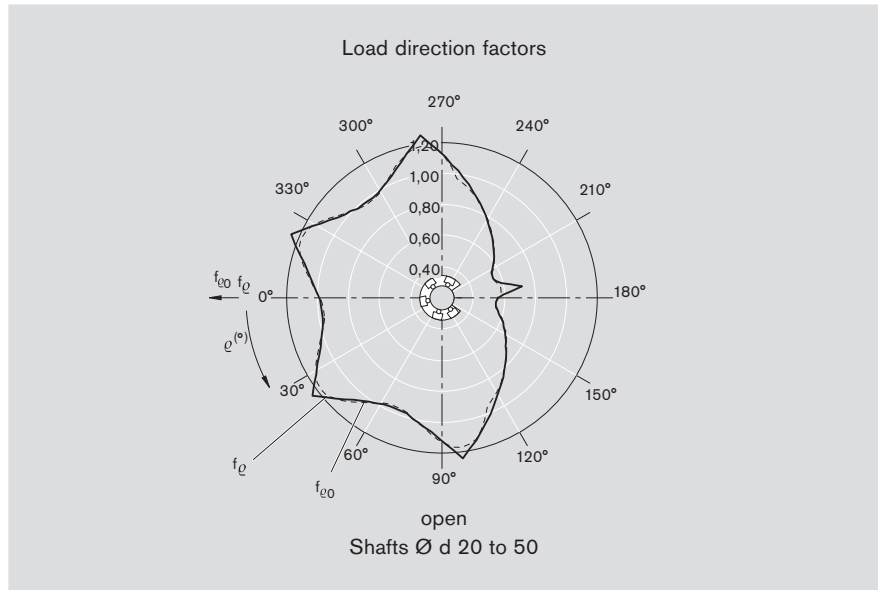

Shaft Ø d [mm]	Part numbers		Mass [kg]
	with Super Linear Bushing A easy re-lubrication with two seals	with Super Linear Bushing B easy re-lubrication with two seals	
20	R1071 620 20	R1071 820 20	0.42
25	R1071 625 20	R1071 825 20	0.8
30	R1071 630 20	R1071 830 20	1.2
40	R1071 640 20	R1071 840 20	2.0
50	R1071 650 20	R1071 850 20	3.2



Shaft Ø d [mm]	Part numbers		Mass [kg]
	with Super Linear Bushing A easy re-lubrication with two seals	with Super Linear Bushing B easy re-lubrication with two seals	
20	R1072 620 20	R1072 820 20	0.42
25	R1072 625 20	R1072 825 20	0.8
30	R1072 630 20	R1072 830 20	1.2
40	R1072 640 20	R1072 840 20	2.0
50	R1072 650 20	R1072 850 20	3.2

Dimensions

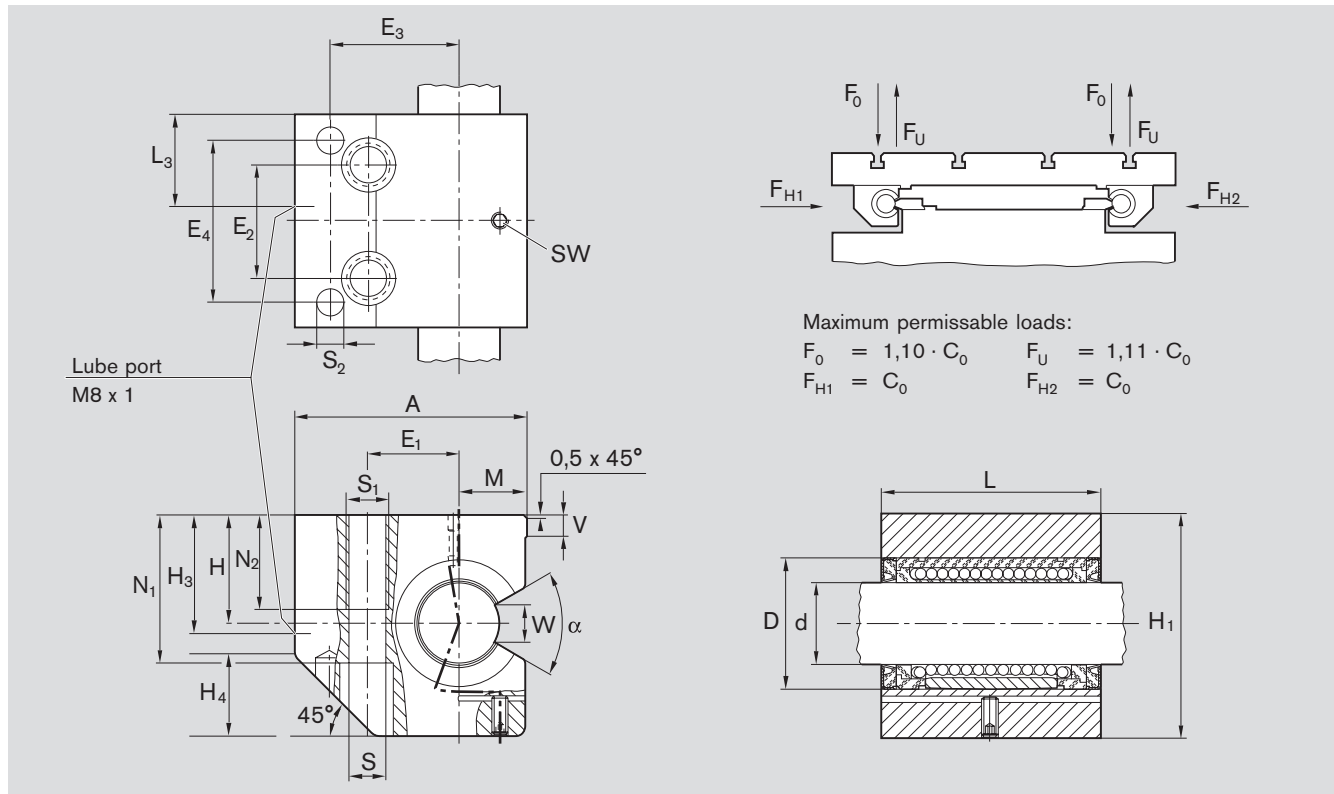

Maximum permissible loads:
 $F_0 = 1,10 \cdot C_0$ $F_U = 1,11 \cdot C_0$
 $F_{H1} = C_0$ $F_{H2} = C_0$

Ø d	D	H ²⁾	H ₁	M ²⁾	A	L	Dimensions [mm]														
							E ₁	E ₂	E ₃	E ₄	S ³⁾	S ₁	S ₂ ⁴⁾	N ₁	N ₂	V	SW	W ⁵⁾	H ₃	L ₃	H ₄
20 ¹⁾	32	30	60	17	60	54	22	30	33	42	8.4	M10	6	42	15	5	2.5	9	32	23.5	22
25 ¹⁾	40	35	72	21	75	67	28	36	42	52	10.5	M12	8	50	18	6.5	3	11.5	38	29	26
30	47	40	82	25	86	79	34	42	48	60	13.5	M16	10	55	24	8	3	14	44	34	30
40	62	45	100	32	110	91	43	48	62	68	15.5	M20	12	67	30	10	4	19.5	50	40	38
50	75	50	115	38	127	113	50	62	70	85	17.5	M20	12	78	30	12	5	22.5	56	48	45

Shaft Ø d	Angle α	Radial clearance ⁶⁾ [µm]		Load capacities ⁷⁾ [N]	
		R1071	R1072		dyn. C
[mm]	[°]	h6	h7		
20 ¹⁾	55	+31	+37	2100	1070
25 ¹⁾	57	+31	+37	4130	2250
30	57	+31	+37	5020	2880
40	56	+35	+42	8620	4480
50	54	+35	+42	12500	6620

Adjusted zero-clearance on h5 shaft (lower limit) prior to delivery to when screwed down

- 1) In these sizes, the locating screw is on the opposite side to that shown in the illustration.
- 2) When screwed down, relative to shaft nominal dimension d.
- 3) Mounting screws to ISO 4762-8.8.
- 4) Center-bores for locating pin holes.
- 5) Minimum dimension based on shaft diameter d.
- 6) When screwed down.
- 7) The load capacities apply when the load is acting in the direction shown by the arrows at F_{H1} or F_{H2}

The figures for dynamic load-carrying capacity have been calculated assuming a nominal travel of 100,000 m. For a nominal travel of 50,000 m, the 'C' figures in the table must be multiplied by a factor of 1.26.

Please refer also to the mounting instructions for Linear Sets with side opening.

Linear Sets with Super Linear Bushings  Tandem

Linear Sets, R1085
closed

Linear Sets, R1032
adjustable

Structural design

- Precision Tandem Linear Set, lightweight series (aluminum)
- Two Super Linear Bushings 
- External seals
- Fully sealed
- Fitting edge (for adjustable Tandem version)
- Easy re-lubrication



Shaft Ø d [mm]	Part numbers	Mass [kg]
12	R1085 612 20	0.27
16	R1085 616 20	0.41
20	R1085 620 20	0.72
25	R1085 625 20	1.35
30	R1085 630 20	2.01
40	R1085 640 20	3.67
50	R1085 650 20	6.30



Shaft Ø d [mm]	Part numbers	Mass [kg]
10	R1032 610 20	0.20
12	R1032 612 20	0.27
16	R1032 616 20	0.41
20	R1032 620 20	0.72
25	R1032 625 20	1.35
30	R1032 630 20	2.01
40	R1032 640 20	3.67
50	R1032 650 20	6.30

Also available as a linear slide,
see our "Linear Slide" catalog.

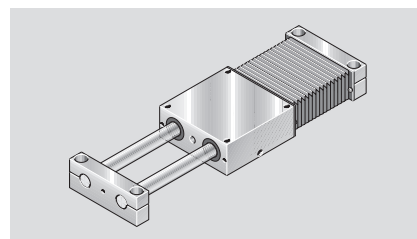

Dimensions

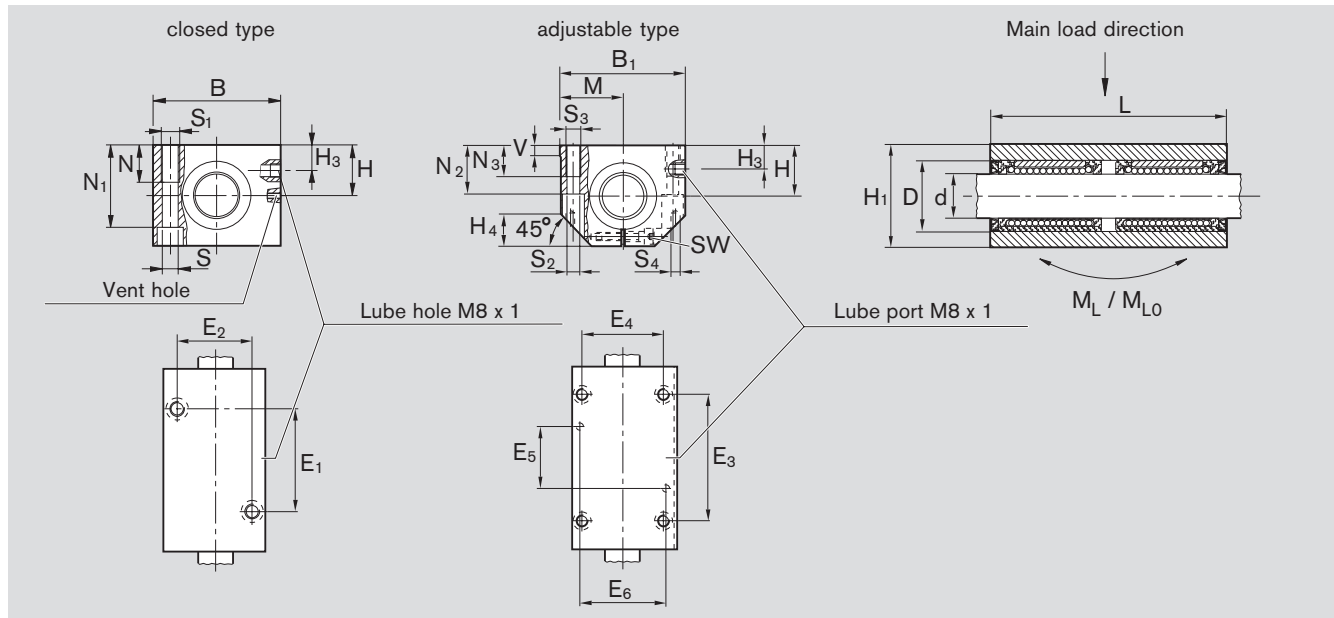

Dimensions [mm]																										
Ø d	D	H ¹⁾	H ₁	H ₃	M ¹⁾	B	B ₁	L	E ₁ ²⁾	E ₂ ²⁾	E ₃ ²⁾	E ₄ ²⁾	E ₅	E ₆	S ³⁾	S ₁	S ₂ ³⁾	S ₃	S ₄ ⁴⁾	N	N ₁	N ₂	N ₃	V	SW	H ₄
	+0.008				±0.01				±0.15	±0.15	±0.15	±0.15														
10	19	16	31.5	9	20	-	40	70	-	-	52	29	20	31	-	-	4.3	M5	4	-	-	15	11	5	2.5	10
12	22	18	35	10	21.5	42	43	76	40	30	56	32	24	34	5.3	M6	4.3	M5	4	13	28	16.5	11	5	2.5	10
16	26	22	42	12	26.5	50	53	84	45	36	64	40	28	42	5.3	M6	5.3	M6	4	13	35	21	13	5	3	13
20	32	25	50	13	30	60	60	104	55	45	76	45	32	50	6.6	M8	6.6	M8	5	18	41	24	18	5	4	16
25	40	30	60	15	39	74	78	130	70	54	94	60	42	64	8.4	M10	8.4	M10	6	22	49	29	22	6.5	5	20
30	47	35	70	16	43.5	84	87	152	85	62	106	68	52	72	10.5	M12	8.4	M10	6	26	56	34	22	8	5	22
40	62	45	90	20	54	108	108	176	100	80	124	86	60	90	13.5	M16	10.5	M12	8	34	74	44	26	10	6	28
50	75	50	105	20	66	130	132	224	125	100	160	108	80	108	13.5	M16	13.5	M16	10	34	89	49	35	12	8	37

Shaft Ø d [mm]	Radial clearance [µm]		Load capacities ⁵⁾ [N]		Tipping Moment [Nm]	
	R1085 Shaft h6	R1032 h7	dyn. C	stat. C ₀	dyn. M _L	stat. M _{L0}
10	-	-	1180	760	17	12
12	+38 +10	+43 +12	1660	980	26	16
16	+38 +10	+43 +12	2030	1240	35	22
20	+43 +11	+49 +13	4010	2680	84	54
25	+43 +11	+49 +13	7830	5580	205	140
30	+43 +11	+49 +13	9520	7140	289	206
40	+50 +12	+57 +14	16360	11140	576	374
50	+50 +12	+57 +14	23930	16560	1097	725

Adjusted to zero-clearance on h5 shaft (lower limit) prior to delivery when screwed down

- 1) When screwed down, relative to shaft nominal dimension d.
- 2) Shafts Ø 50: Tolerance ± 0.2
- 3) Mounting screws to ISO 4762-8.8.
- 4) Center-bores for locating pin holes.
- 5) Load capacity when both Linear Bushings are equally loaded. The load capacities stated are minimum values as the position and direction of load cannot always be precisely defined. If the load direction is not the main load direction, the load capacities are to be multiplied by the following factors:
Shafts-Ø 10 to 16: f = 0.82 f₀ = 0.86
Shafts-Ø 20 to 50: f = 0.82 f₀ = 0.78

Note on lubrication for Linear Sets R1085:
Lubricate only when shaft inserted; add lubricant until excess emerges at the vent hole.

The figures for dynamic load-carrying capacity have been calculated assuming a nominal travel of 100,000 m. For a nominal travel of 50,000 m, the 'C' figures in the table must be multiplied by a factor of 1.26.

Linear Sets with Super Linear Bushings  Tandem version

Linear-Sets, R1087
open

Linear-Sets, R1034
open, adjustable

Structural design

- Precision Tandem Linear Set, lightweight series (Aluminum)
- Two Super Linear Bushings 
- Two external seals
- Fitting edge (for adjustable tandem version)
- Easy re-lubrication

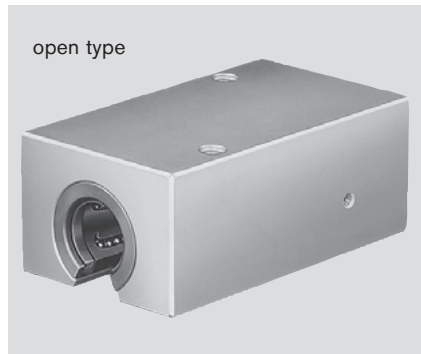

Shaft Ø d [mm]	Part numbers	Mass [kg]
12	R1087 612 20	0.22
16	R1087 616 20	0.34
20	R1087 620 20	0.62
25	R1087 625 20	1.17
30	R1087 630 20	1.68
40	R1087 640 20	3.15
50	R1087 650 20	5.50

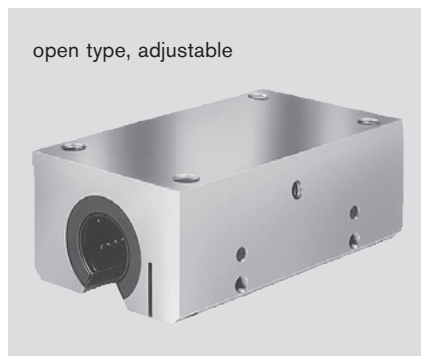

Shaft Ø d [mm]	Part numbers	Mass [kg]
12	R1034 612 20	0.22
16	R1034 616 20	0.34
20	R1034 620 20	0.62
25	R1034 625 20	1.17
30	R1034 630 20	1.68
40	R1034 640 20	3.15
50	R1034 650 20	5.50

Also available as a linear slide,
see our "Linear Slide" catalog.

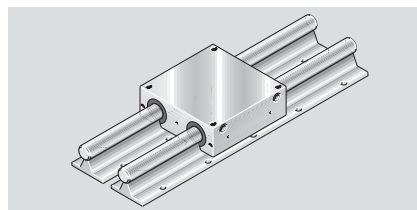

Dimensions

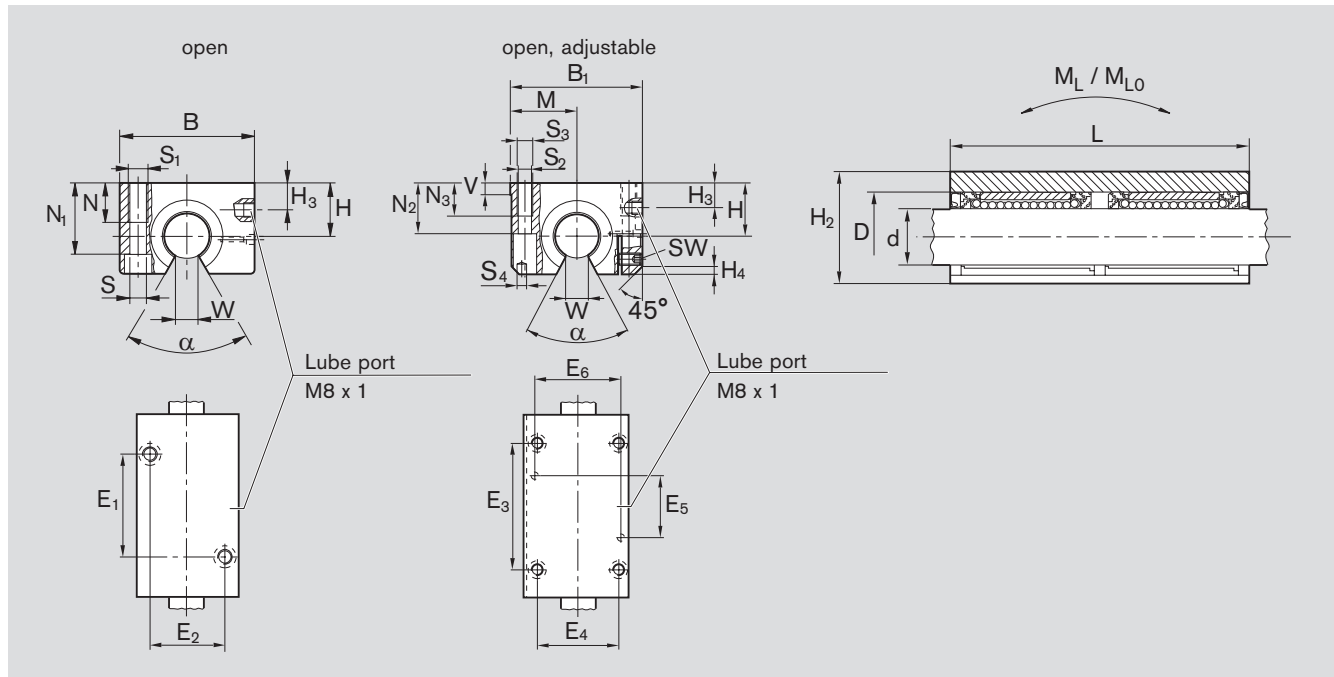

		Dimensions [mm]																											
Ø d	D	H ²⁾	H ₂	H ₃	M ²⁾	B	B ₁	L	E ₁ ³⁾	E ₂ ³⁾	E ₃ ³⁾	E ₄ ³⁾	E ₅	E ₆	S ⁴⁾	S ₁	S ₂ ⁵⁾	S ₃	S ₄ ⁶⁾	N	N ₁	N ₂	N ₃	V	SW	W ⁷⁾	H ₄		
		+0.008			±0.01				±0.15	±0.15	±0.15	±0.15																	
12	22	18	30 ¹⁾	10	21.5	42	43	76	40	30	56	32	24	34	5.3	M6	4.3	M5	4	13	25	16.5	11	5	2.5	6.5	1.5		
16	26	22	35	12	26.5	50	53	84	45	36	64	40	28	42	5.3	M6	5.3	M6	4	13	29.5	21	13	5	2.5	9	2.5		
20	32	25	42	13	30	60	60	104	55	45	76	45	32	50	6.6	M8	6.6	M8	5	18	35.5	24	18	5	2.5	9	3.5		
25	40	30	51	15	39	74	78	130	70	54	94	60	42	64	8.4	M10	8.4	M10	6	22	43	29	22	6.5	3	11.5	4		
30	47	35	60	16	43.5	84	87	152	85	62	106	68	52	72	10.5	M12	10.5	M12	8	26	50.5	34	22	8	3	14	6		
40	62	45	77	20	54	108	108	176	100	80	124	86	60	90	13.5	M16	10.5	M12	8	34	66	44	26	10	4	19.5	6		
50	75	50	88	10	66	130	132	224	125	100	160	108	80	108	13.5	M16	13.5	M16	10	34	77	49	35	12	5	22.5	6		

Shaft Ø d [mm]	Angle α [°]	Radial clearance ⁸⁾		Load capacities ⁹⁾ [N]		Tipping moment [Nm]	
		R1087 [µm] Shaft h6	R1034 h7	dyn. C	stat. C ₀	dyn. M _L	stat. M _{L0}
12	66	+28	+33	1720	1020	11	7
16	68	+28	+33	2080	1260	16	10
20	55	+31	+37	3410	2140	48	30
25	57	+31	+37	6710	4500	116	79
30	57	+31	+37	8150	5760	163	116
40	56	+35	+42	14000	8960	328	212
50	54	+35	+42	20300	13240	630	415

Adjusted to zero-clearance on h5 shaft (lower limit) prior to delivery when screwed down

- ¹⁾ In the open type, adjustable version H₂ = 28 mm.
- ²⁾ When screwed down, relative to shaft nominal dimension d.
- ³⁾ Shafts Ø 50: Tolerance ± 0.2
- ⁴⁾ Mounting screws to DIN 6912-8.8.
- ⁵⁾ Mounting screws to ISO 4762-8.8.
- ⁶⁾ Center bores for locating pin holes
- ⁷⁾ Minimum dimension based on shaft diameter d.
- ⁸⁾ When screwed down.
- ⁹⁾ When the load capacity of both Linear Bushings is equally distributed. The given load capacities are valid for the main load capacity direction ρ = 0°.

The figures for dynamic load-carrying capacity have been calculated assuming a nominal travel of 100,000 m. For a nominal travel of 50,000 m, the 'C' figures in the table must be multiplied by a factor of 1.26.



Linear Sets with Super Linear Bushings  Tandem flanged versionLinear Sets, R1083
Flanged version

Structural desing

- Precision flanged housing, lightweight series (Aluminum)
- Two Super Linear Bushings 
- Two external seals
- Centering collar
- Fully sealed
- Tapped through holes for screw-mounting from the base
- Easy re-lubrication
- Radial clearance not adjustable

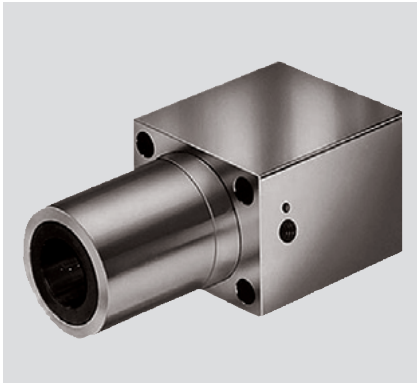

Shaft Ø d [mm]	Part numbers	Mass [kg]
12	R1083 612 20	0.20
16	R1083 616 20	0.32
20	R1083 620 20	0.55
25	R1083 625 20	1.00
30	R1083 630 20	1.50

Dimensions

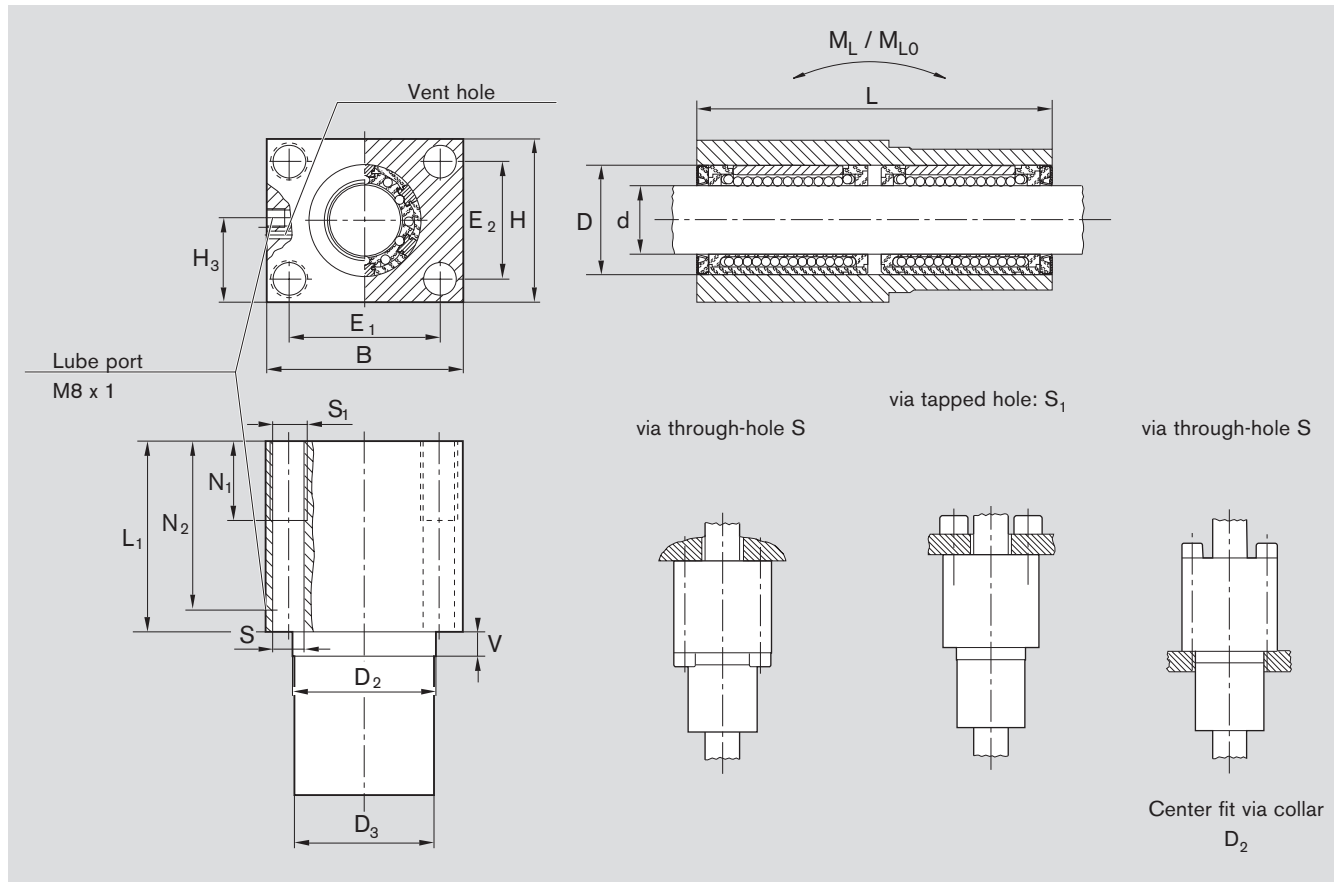

Dimensions [mm]															
Ø d	D	D ₂ ¹⁾	D ₃	H	H ₃	B	L	L ₁	E ₁	E ₂	S ²⁾	S ₁	N ₁	N ₂	V
		g7	-0.1 -0.3						±0.15	±0.15					
12	22	30	30	34	19	42	76	46	32	24	5.3	M6	13	36	10
16	26	35	35	40	22	50	84	50	38	28	6.6	M8	18	40	10
20	32	42	42	50	27	60	104	60	45	35	8.4	M10	22	50	10
25	40	52	52	60	32	74	130	73	56	42	10.5	M12	26	63	10
30	47	61	61	70	37	84	152	82	64	50	13.5	M16	34	74	10

Shaft Ø d [mm]	Radial clearance [µm]		Load capacities ³⁾ dyn. C [N] stat. C ₀		Tipping Moment [Nm] dyn. M _L stat. M _{L0}	
	+h6	+h7				
12	+38 +10	+43 +12	1350	840	26	16
16	+38 +10	+43 +12	1660	1060	35	22
20	+43 +11	+49 +13	3280	2100	84	54
25	+43 +11	+49 +13	6420	4360	205	140
30	+43 +11	+49 +13	7800	5580	289	206

¹⁾ Recommended mounting bore fit: D₂^{H7}.

²⁾ Mounting screws to ISO 4762-8.8.

³⁾ Load capacities stated are minimum values as the position and direction of load cannot always be precisely defined.

Note on lubrication:

Lubricate only when shaft inserted; add lubricant until excess emerges at the vent hole.

The figures for dynamic load-carrying capacity have been calculated assuming a nominal travel of 100,000 m. For a nominal travel of 50,000 m, the 'C' figures in the table must be multiplied by a factor of 1.26.

Linear-Sets mit Super-Linear Bushings **A** oder **B**, Guss-Gehäuse

Linear Sets, R1065
closed type

Linear Sets, R1066
adjustable type

Structural design

- Precision housing (lamellar graphite cast iron)
- Super Linear Bushing with or without self-alignment
- Internal seals

closed type



Shaft Ø d [mm]	Part numbers		Mass [kg]
	with Super Linear Bushing A with internal seals	with Super Linear Bushing B with internal seals	
12	R1065 612 40	R1065 812 40	0.15
16	R1065 616 40	R1065 816 40	0.24
20	R1065 620 40	R1065 820 40	0.42
25	R1065 625 40	R1065 825 40	0.83
30	R1065 630 40	R1065 830 40	1.22
40	R1065 640 40	R1065 840 40	2.29
50	R1065 650 40	R1065 850 40	3.23

adjustable type



Shaft Ø d [mm]	Part numbers		Mass [kg]
	with Super Linear Bushing A with internal seals	with Super Linear Bushing B with internal seals	
12	R1066 612 40	R1066 812 40	0.15
16	R1066 616 40	R1066 816 40	0.24
20	R1066 620 40	R1066 820 40	0.41
25	R1066 625 40	R1066 825 40	0.79
30	R1066 630 40	R1066 830 40	1.19
40	R1066 640 40	R1066 840 40	2.26
50	R1066 650 40	R1066 850 40	3.15

Dimensions

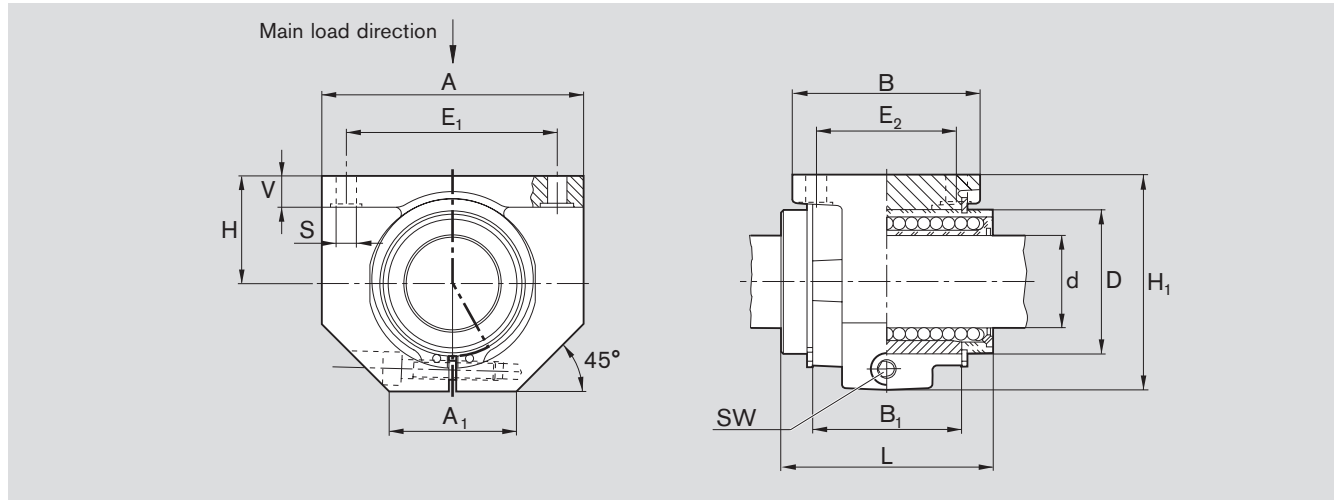

Dimensions [mm]													
Ø d	D	H	H ₁ ¹⁾	L	A ¹⁾	A ₁ ¹⁾	B ¹⁾	B ₁	E ₁	E ₂	S	V ¹⁾	SW
12	22	18	35	32	42	21	32	20	32±0.15	23±0.15	4.5	5.5	2.5
16	26	22	42	36	50	26	35	22	40±0.15	26±0.15	4.5	6.5	3
20	32	25	50	45	60	28	42	28	45±0.15	32±0.15	4.5	8	3
25	40	30	60	58	74	38	54	40	60±0.15	40±0.15	5.5	9	5
30	47	35	70	68	84	41	60	48	68±0.20	45±0.20	6.6	10	5
40	62	45	90	80	108	51	78	56	86±0.20	58±0.20	9	12	6
50	75	50	105	100	130	57	70	72	108±0.20	50±0.20	9	14	8

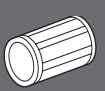

Shaft Ø d [mm]	Radial clearance [µm]		Tolerance for H ²⁾ [µm]	Load capacities ³⁾ [N]	
	R1065 Shaft h6	R1066 h7		dyn. C	stat. C ₀
12	+38	+43	+8 -16	1020	490
	+10	+12			
16	+38	+43	+8 -16	1250	620
	+10	+12			
20	+43	+49	+8 -16	2470	1340
	+11	+13			
25	+43	+49	+8 -16	4820	2790
	+11	+13			
30	+43	+49	+8 -16	5860	3570
	+11	+13			
40	+50	+57	+8 -16	10070	5570
	+12	+14			
50	+50	+57	+13 -21	14730	8280
	+12	+14			

Adjusted to zero-clearance on h5 shaft (lower limit) prior to delivery when screwed down

¹⁾ Tolerance DIN 1686-GTB15.
²⁾ When screwed down, relative to shaft nominal dimension d.
³⁾ The load capacities stated are minimum values as the position and direction of load cannot always be precisely defined. If the load direction is not the main load direction, the load capacities are to be multiplied by the following factors:
 Shafts-Ø 10 to 16: f = 0.82 f₀ = 0.86
 Shafts-Ø 20 to 50: f = 0.82 f₀ = 0.78

The figures for dynamic load-carrying capacity have been calculated assuming a nominal travel of 100,000 m. For a nominal travel of 50,000 m, the 'C' figures in the table must be multiplied by a factor of 1.26.

Dimensions

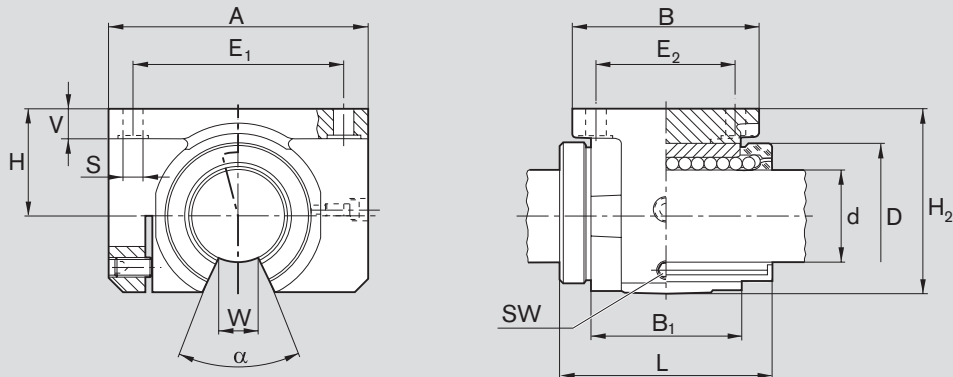

Dimensions [mm]														
Ø d	D	H	H ₂ ²⁾	L	A ²⁾	B ²⁾	B ₁	E ₁	E ₂	S	V ²⁾	W ³⁾	SW	
12 ¹⁾	22	18	28	32	42	32	20	32±0.15	23±0.15	4.5	5.5	6.5	2.5	
16 ¹⁾	26	22	35	36	50	35	22	40±0.15	26±0.15	4.5	6.5	9	2.5	
20 ¹⁾	32	25	42	45	60	42	28	45±0.15	32±0.15	4.5	8	9	2.5	
25 ¹⁾	40	30	51	58	74	54	40	60±0.15	40±0.15	5.5	9	11.5	3	
30	47	35	60	68	84	60	48	68±0.20	45±0.20	6.6	10	14	3	
40	62	45	77	80	108	78	56	86±0.20	58±0.20	9	12	19.5	4	
50	75	50	88	100	130	70	72	108±0.20	50±0.20	9	14	22.5	5	

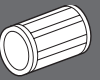

Shaft Ø d [mm]	Angle α [°]	Radial clearance [µm]		Tolerance for H ⁴⁾ [µm]	Load capacities ⁵⁾ [N]	
		R1067 h6	R1068 h7		dyn. C	stat. C ₀
12	66	+28 -1	+33 +1	+8 -16	1060	510
16	68	+28 -1	+33 +1	+8 -16	1280	630
20	55	+31 -2	+37 0	+8 -16	2100	1070
25	57	+31 -2	+37 0	+8 -16	4130	2250
30	57	+31 -2	+37 0	+8 -16	5020	2880
40	56	+35 -3	+42 -1	+8 -16	8620	4480
50	54	+35 -3	+42 -1	+13 -21	12500	6620

Adjusted to zero-clearance on h5 shaft (lower limit) prior to delivery when screwed down

- ¹⁾ In these sizes, the locating screw is on the opposite side to that shown in the illustration.
- ²⁾ Tolerance DIN 1685-GTB15.
- ³⁾ Minimum dimension based on shaft diameter d.
- ⁴⁾ When screwed down, relative to shaft nominal dimension d.
- ⁵⁾ The given load capacities are valid for the main load capacity direction ρ = 0°.

The figures for dynamic load-carrying capacity have been calculated assuming a nominal travel of 100,000 m. For a nominal travel of 50,000 m, the 'C' figures in the table must be multiplied by a factor of 1.26.

Linear Sets with Super Linear Bushings **A** or **B**, cast iron housing

Linear Sets, R1073
with side opening

Linear Sets, R1074
with side opening, adjustable

Structural design

- Precision housing (spheroidal graphite cast iron)
- Retention by means of locating screw
- Super Linear Bushing with or without self-alignment
- Internal seals

The load carrying capacity of open linear bushings is considerably reduced when the load is applied to the "open" portion of the bushing. The Linear Set with side opening has been developed to overcome this disadvantage and to permit selective circumferential positioning of the open linear bushing.

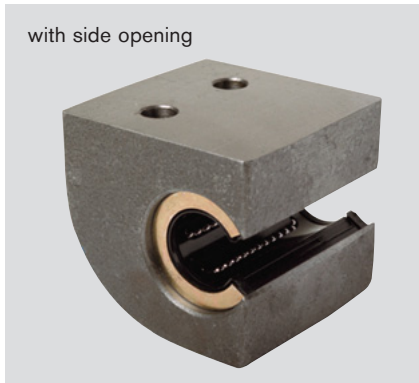
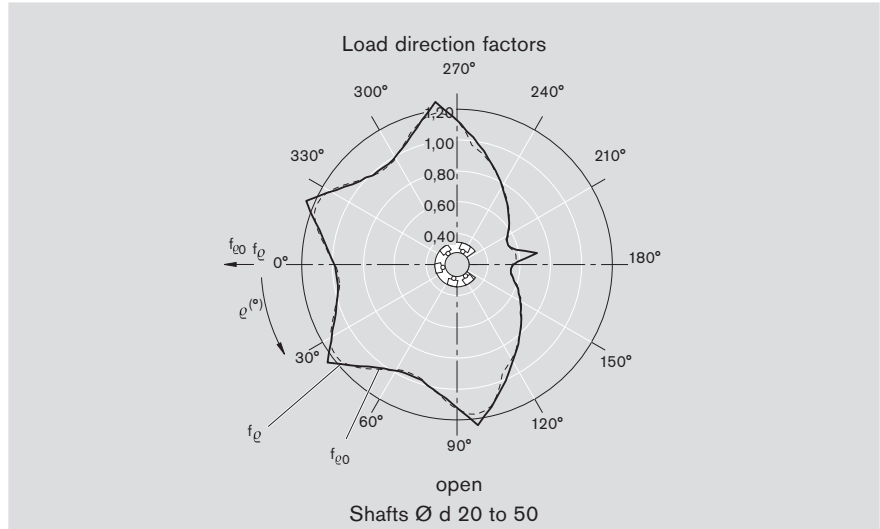

Shaft Ø d [mm]	Part numbers		Mass [kg]
	with Super Linear Bushing A with two seals	with Super Linear Bushing B with two seals	
20	R1073 620 00	R1073 820 00	1.0
25	R1073 625 00	R1073 825 00	1.9
30	R1073 630 00	R1073 830 00	2.8
40	R1073 640 00	R1073 840 00	4.8
50	R1073 650 00	R1073 850 00	8.0



Shaft Ø d [mm]	Part numbers		Mass [kg]
	with Super Linear Bushing A with two seals	with Super Linear Bushing B with two seals	
20	R1074 620 00	R1074 820 00	1.0
25	R1074 625 00	R1074 825 00	1.9
30	R1074 630 00	R1074 830 00	2.8
40	R1074 640 00	R1074 840 00	4.8
50	R1074 650 00	R1074 850 00	8.0

Dimensions

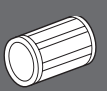
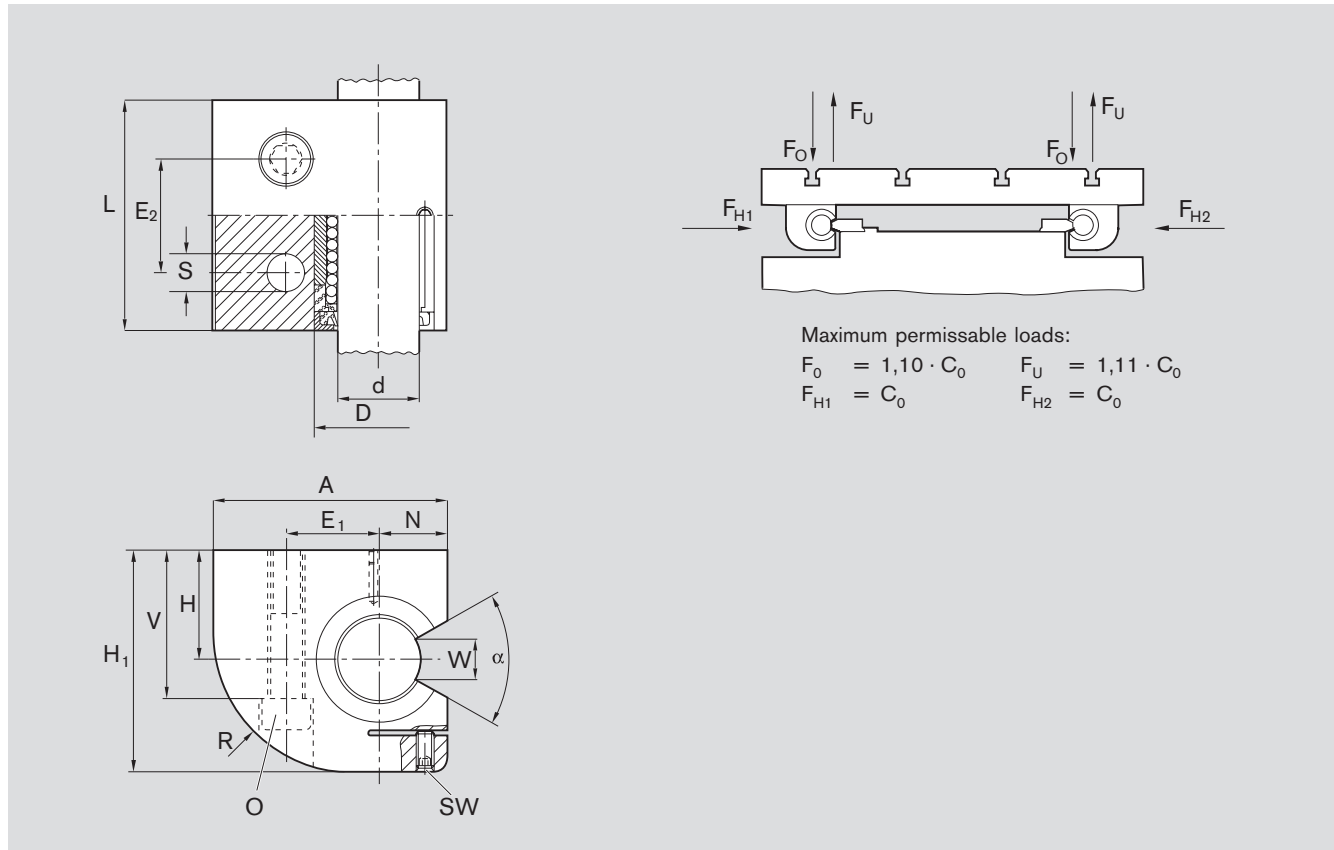

Dimensions [mm]															
Ø d	H	H ₁ ²⁾	L ²⁾	A ²⁾	E ₁	E ₂	N	D	V	S	SW	O ³⁾	R ²⁾	W ⁴⁾	
20 ¹⁾	30	60	60	60	22±0.25	30±0.25	17	32	42	9	2.5	M8x60	37	9	
25 ¹⁾	35	72	73	75	28±0.25	36±0.25	21	40	50	11	3	M10x70	45	11.5	
30	40	82	85	86	34±0.5	42±0.5	25	47	55	13.5	3	M12x80	51	14	
40	45	100	97	110	43±0.5	48±0.5	32	62	67	15.5	4	M14x90	66	19.5	
50	50	115	125	127	50±0.5	62±0.5	38	75	78	17.5	5	M16x110	77	22.5	

Shaft Ø d [mm]	Angle α [°]	Radial clearance ⁵⁾ [µm]		Tolerance for H ⁶⁾ [µm]	Load capacities ⁷⁾ [N]	
		R1073 h6	R1074 h7		dyn. C	stat. C ₀
20 ¹⁾	55	+31 -2	+37 0	+8 -16	2100	1070
25 ¹⁾	57	+31 -2	+37 0	+8 -16	4130	2250
30	57	+31 -2	+37 0	+8 -16	5020	2880
40	56	+35 -3	+42 -1	+8 -16	7680	4480
50	54	+35 -3	+42 -1	+13 -21	12500	6620

Adjusted to zero-clearance on h5 shaft (lower limit) prior to delivery when screwed down

- ¹⁾ In these sizes, the locating screw is on the opposite side to that shown in the illustration.
- ²⁾ Tolerance DIN 1685-GTB 16.
- ³⁾ Hex. socket head cap screws to ISO 4762-8.8.
- ⁴⁾ Minimum dimension based on shaft diameter d.
- ⁵⁾ When screwed down.
- ⁶⁾ Relative to shaft nominal dimension d.
- ⁷⁾ The load capacities apply when the load is acting in the direction shown by the arrows at F_{H1} or F_{H2}

The figures for dynamic load-carrying capacity have been calculated assuming a nominal travel of 100,000 m. For a nominal travel of 50,000 m, the 'C' figures in the table must be multiplied by a factor of 1.26.

Linear-Sets with Super Linear Bushings **A** or **B**, cast iron housing

Linear Sets, R1081 Flanged type

Structural design

- Precision housing (lamellar graphite cast iron)
- Two retaining rings plus two spacer rings (steel) for sizes 12 to 40
- Super Linear Bushing with or without self-alignment feature
- Internal seals
- The radial clearance is not adjustable



Shaft Ø d [mm]	Part numbers		Mass [kg]
	with Super Linear Bushing A with two seals	with Super Linear Bushing B with two seals	
12	R1081 612 40	R1081 812 40	0.095
16	R1081 616 40	R1081 816 40	0.16
20	R1081 620 40	R1081 820 40	0.30
25	R1081 625 40	R1081 825 40	0.57
30	R1081 630 40	R1081 830 40	0.85
40	R1081 640 40	R1081 840 40	1.65
50	R1081 650 40	R1081 850 40	3.40

Dimensions

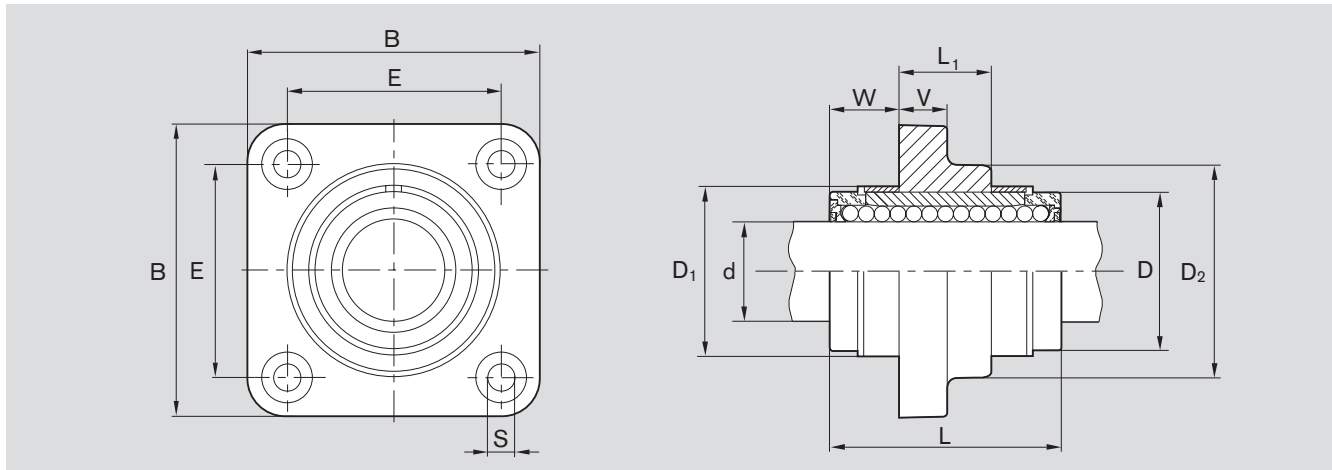

Ø d	B ¹⁾	L	L ₁	D	Dimensions [mm]		E	S	V ¹⁾	W
					D ₁ +0,8	D ₂ ¹⁾				
12	42	32	12	22	24	28	30±0.12	5.5	6	10
16	50	36	15	26	28,5	34	35±0.12	5.5	8	10.5
20	60	45	18	32	35	42	42±0.15	6.6	10	13.5
25	74	58	23	40	43	54	54±0.15	6.6	12	17.5
30	84	68	26	47	49,5	62	60±0.25	9.0	14	21
40	108	80	36	62	66,5	80	78±0.25	11	16	22
50	130	100	72	75	81	98	98±0.25	11	18	14

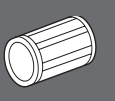

Shaft Ø d [mm]	Radial clearance [µm]		Load capacities [N]	
	Shaft		dyn. C	stat. C ₀
	h6	h7		
12	+38 +10	+43 +12	830	420
16	+38 +10	+43 +12	1020	530
20	+43 +11	+49 +13	2020	1050
25	+43 +11	+49 +13	3950	2180
30	+43 +11	+49 +13	4800	2790
40	+50 +12	+57 +14	8240	4350
50	+50 +12	+57 +14	12060	6470

¹⁾ Tolerance DIN 1686-GTB15.

The figures for dynamic load-carrying capacity have been calculated assuming a nominal travel of 100,000 m. For a nominal travel of 50,000 m, the 'C' figures in the table must be multiplied by a factor of 1.26.

Standard Linear Bushings

The Advantages

- Robust steel enclosure suitable for environments with high contamination
- For use in woodworking, foundries, cement works
- Also in corrosion-resistant for the medical, chemical and food industries
- Several cavities serve as lubricant reservoirs for extended lubrication intervals or duty-cycle lubrication
- These cavities can also capture invading dirt, preventing potential blockage of the Linear Bushing
- Available without seals and steel enclosures for applications requiring very high temperatures i.e. vacuums
- Various flange styles
- With or without internal seals
- Linear Sets with cast iron housing



closed type



adjustable type



closed type

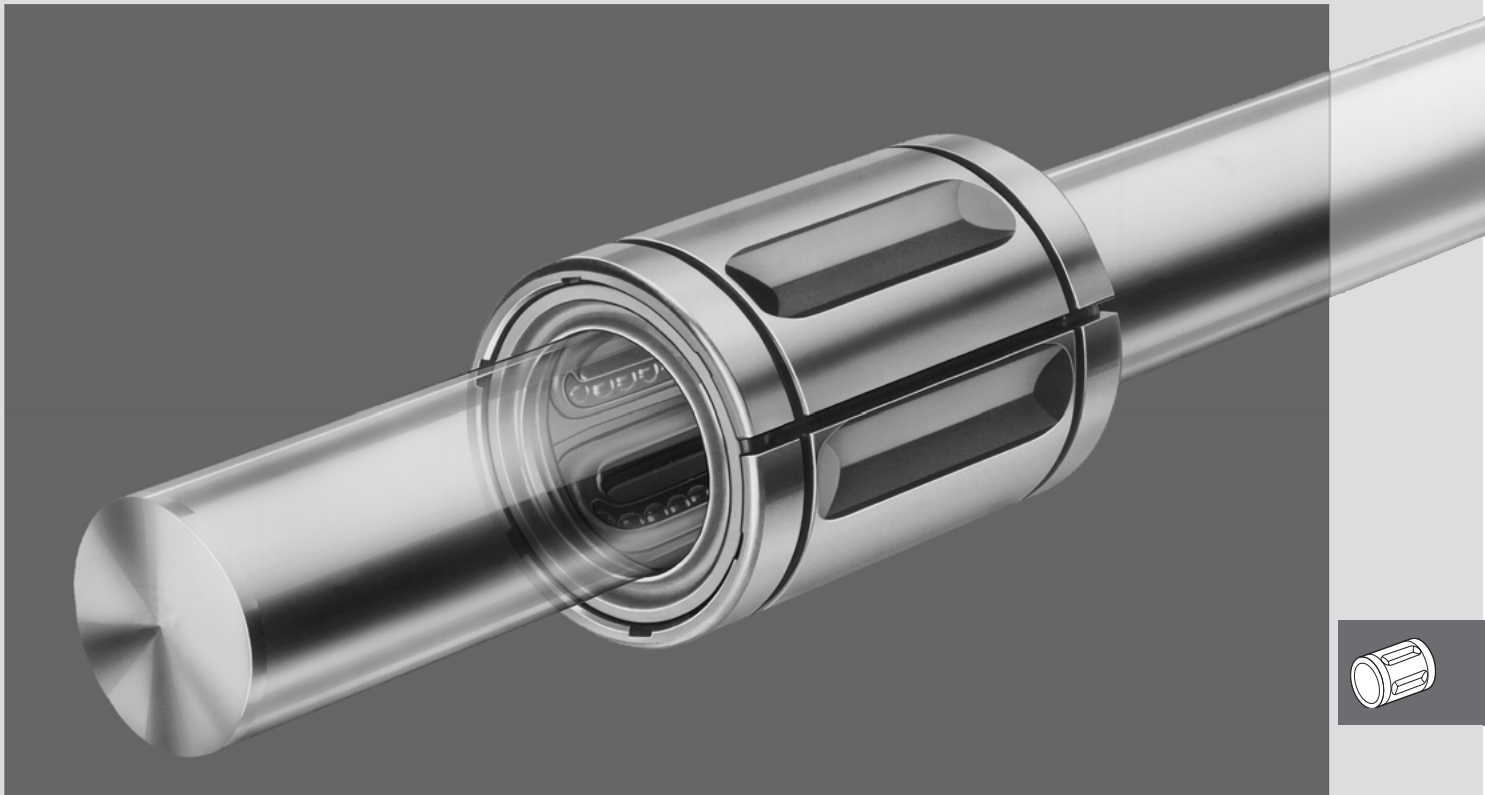

tandem



flanged type

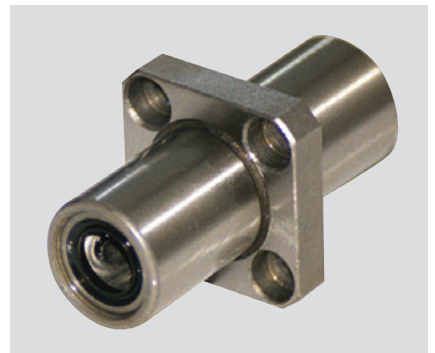

middle flanged type

Standard Linear Bushings

Technical Data

Please observe the general technical principles and mounting instructions at the beginning of this catalog as well as the additional technical data given below.

Outer dimensions/interchangeability

Standard Linear Bushings have the same outer dimensions and are therefore interchangeable with Super Linear Bushings (caution: different retention, radial clearance, load capacities and lubrication).

Sealing

Standard Linear Bushings are available with seals. Open type Standard Linear Bushings in sizes 20 to 80 can also be supplied fully sealed (with seal strip), though this will result in greater friction.

Low friction

Very low friction due to the rolling friction principle. Even if the lubricant supply were to run short, there would be no appreciable increase in friction. Extremely low breakaway forces.

The friction μ of unsealed Standard Linear Bushings using oil as a lubricant lies between 0.001 and 0.004.

The friction is lowest under high load. It may, however, be greater than the stated value when only a slight load is applied.

The frictional drag in linear bushings sealed at both ends and not subject to radial loading depends on the speed and the type of lubrication and is shown in the table below.

Shaft Ø d [mm]	closed and adjustable		open	
	Breakaway force [N] approx.	Frictional drag [N] approx.	Breakaway force [N] approx.	Frictional drag [N] approx.
5	0.8	0.4	–	–
8	1	0.5	–	–
10	2	1	–	–
12	6	2	8	3
16	9	3	12	4
20	12	4	16	6
25	14	5	19	7
30	18	6	24	8
40	24	8	32	11
50	30	10	40	14
60	36	12	48	16
80	45	15	60	20

Velocity and acceleration

	v_{\max} [m/s]	a_{\max} [m/s ²]
Standard Linear Bushing $d \leq 40$ mm	2.5	100
Standard Linear Bushing $d \geq 50$ mm	2	50

Operating temperatures

Linear bushings without seals: up to 100 °C. Higher temperatures are permissible for sizes 12 to 80 though at the cost of reduced load capacity (see temperature factor f_t in "General Technical Data and Mounting Instructions").
 Linear bushings with seals: up to 80 °C (brief peaks up to 100 °C).

Direction of load and its influence on the load-carrying capacity of closed and adjustable Standard Linear Bushings

The load capacities given are valid for installation in "min" position and should be taken as the basis for calculation.
 In applications where the direction of load is exactly known and where the Standard Linear Bushings can be mounted in the "max" position, the load capacity rating must be multiplied by the factors f_{max} (dynamic load capacity C) or f_{0max} (static load capacity C_0) from the table.

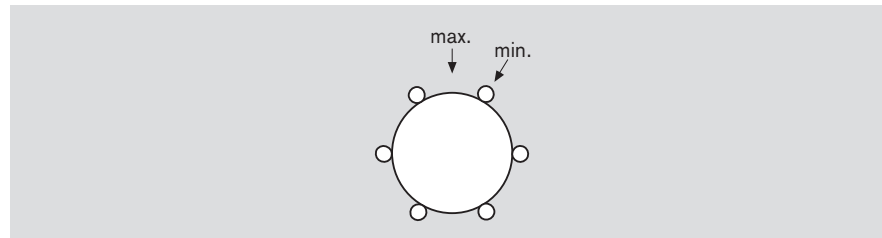

Direction of load and its influence on the load-carrying capacity of open Standard Linear Bushings

The load capacities C and C_0 apply when the load is acting along the line $\varrho = 0^\circ$. If the load is acting in any other direction, these load capacities must be multiplied by the factors f_ϱ (dynamic load capacity C) or $f_{\varrho 0}$ (static load capacity C_0).
 A reduction in the load capacity can be avoided by selective circumferential positioning of the Standard Linear Bushing (see Linear Sets with side opening).

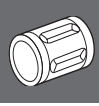

Load capacity factors

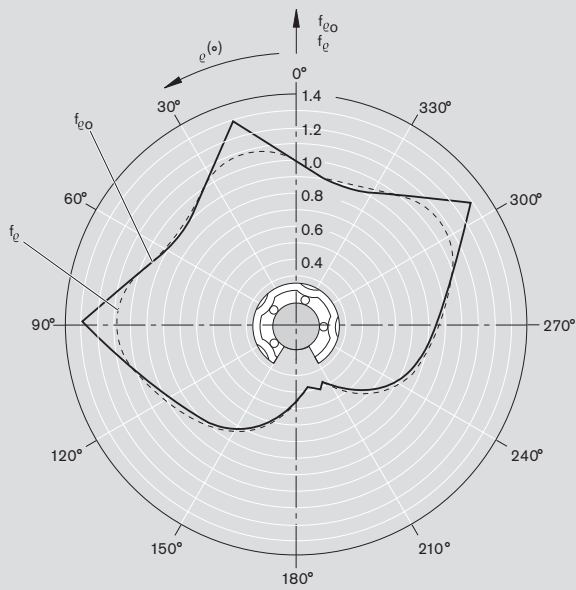

Shafts \varnothing d 20 and 25

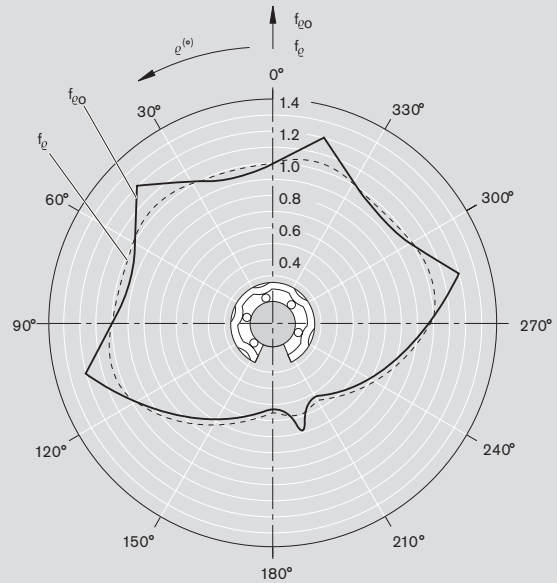

Shafts \varnothing d 30 to 80

Standard Linear Bushings

Custom-built Housings

Retention
Standard Linear Bushings
closed
adjustable

- Retaining rings
- Metal case
- Special design

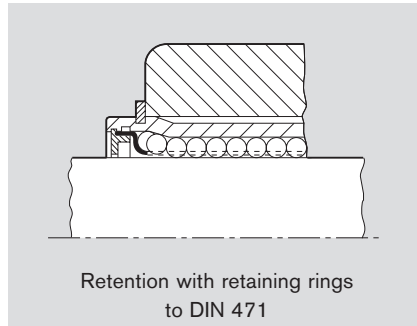

Retention with retaining rings to DIN 471

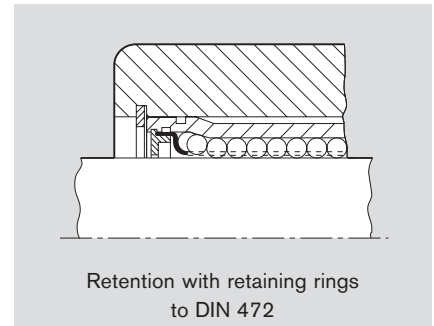

Retention with retaining rings to DIN 472

Shaft Ø d [mm]	Retaining rings DIN 471		Retaining rings DIN 472	
	Part numbers	Dimensions [mm]	Part numbers	Dimensions [mm]
5	R3410 712 00	12 x 1	R3410 207 00	12 x 1
8	R3410 713 00	16 x 1	R3410 208 00	16 x 1
10	R3410 763 00	19 x 1.2	R3410 221 00	19 x 1
12	R3410 714 00	22 x 1.2	R3410 209 00	22 x 1
16	R3410 715 00	27 x 1.2 ¹⁾	R3410 210 00	26 x 1.2
20	R3410 716 00	33 x 1.5 ¹⁾	R3410 211 00	32 x 1.2
25	R3410 717 00	42 x 1.75	R3410 212 00	40 x 1.75
30	R3410 718 00	48 x 1.75	R3410 213 00	47 x 1.75
40	R3410 719 00	62 x 2	R3410 214 00	62 x 2
50	R3410 720 00	75 x 2.5	R3410 215 00	75 x 2.5
60	R3410 721 00	90 x 3	R3410 216 00	90 x 3
80	R3410 722 00	120 x 4	R3410 217 00	120 x 4

¹⁾ Not to DIN 471.

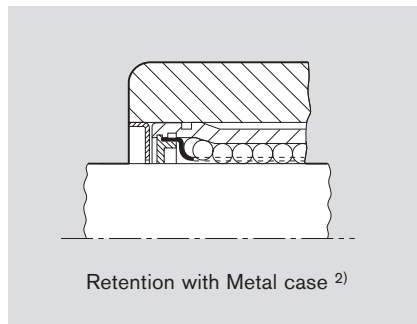
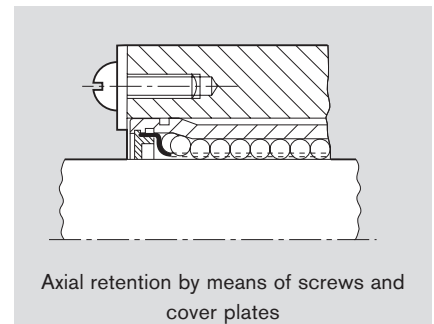
Retention with Metal case ²⁾

Axial retention by means of screws and cover plates

²⁾ For part numbers and dimensions, see Super Linear Bushings [A](#) and [B](#). Custom-built housings.

Standard Linear Bushings
open type

- Dimensions of retention hole

The open type Standard Linear Bushing has been provided with a retention hole, thus allowing axial and radial securing.

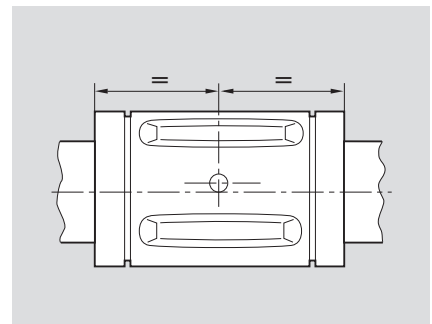
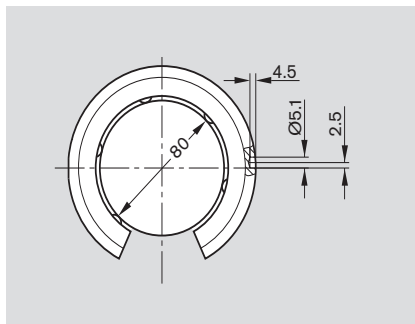
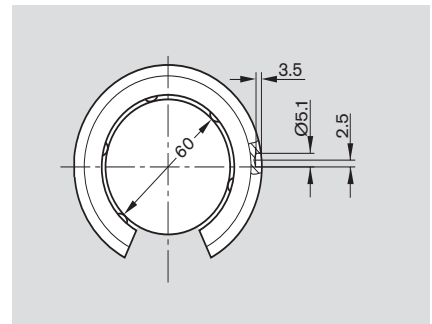
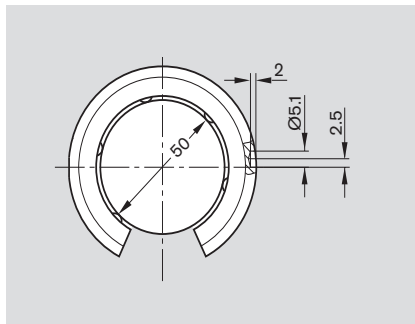
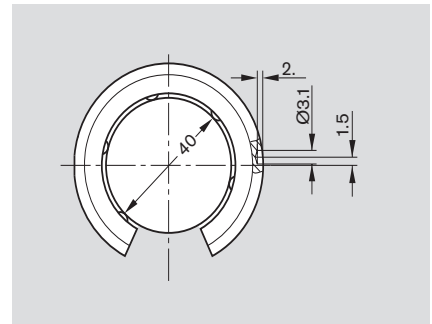
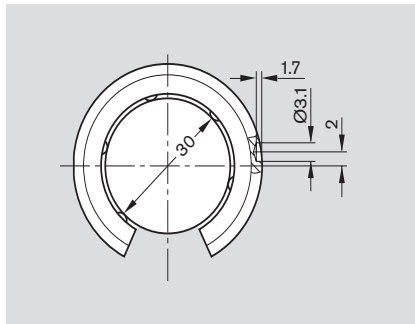
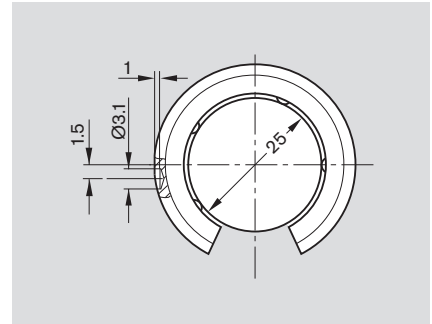
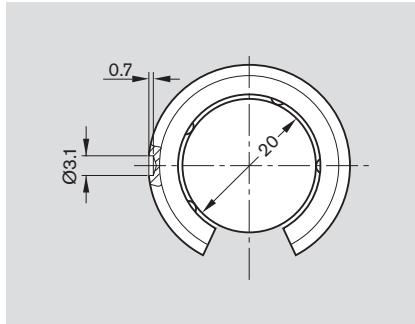

Standard Linear Bushings

Custom-built Housings

- Retention with a locating screw

Points to note when mounting Open type standard Linear Bushing have been provided with the necessary retention hole. On installation, the retention hole in the Linear Bushing must be aligned with the tapped hole in the housing. The screw is then inserted, screwed down to the specified depth and tightened to the specified torque.

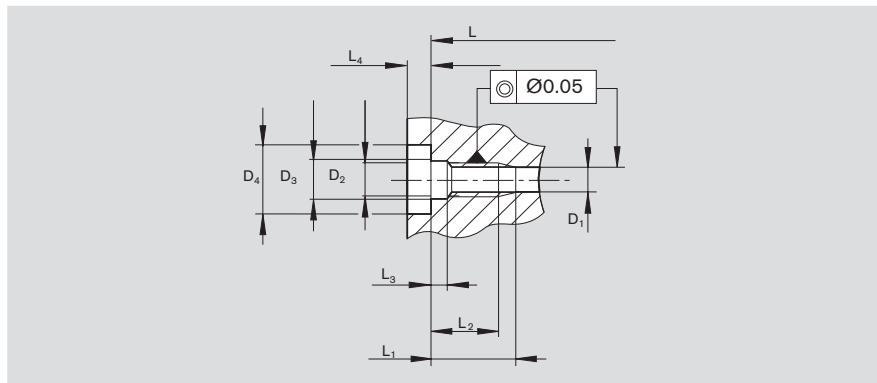
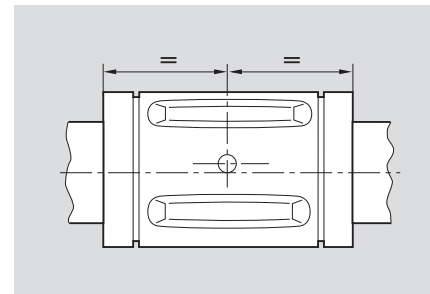
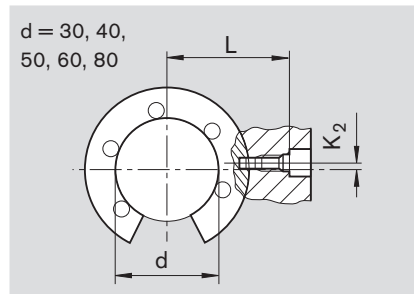
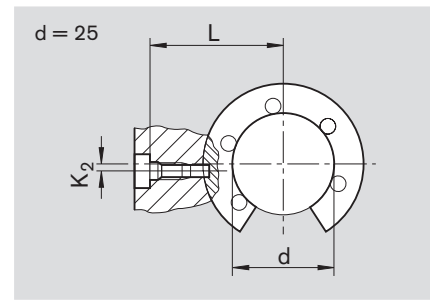
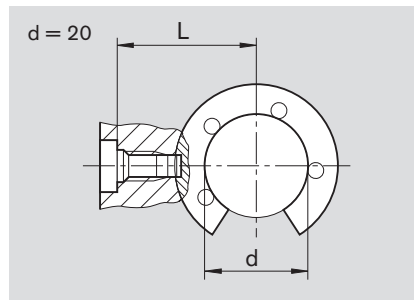

Locating screw

The locating screws are self-adjusting.

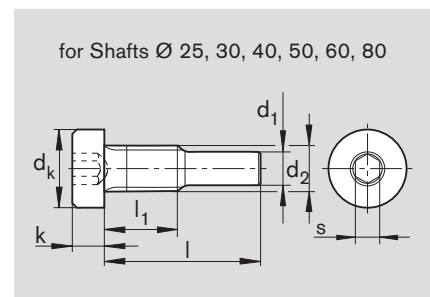
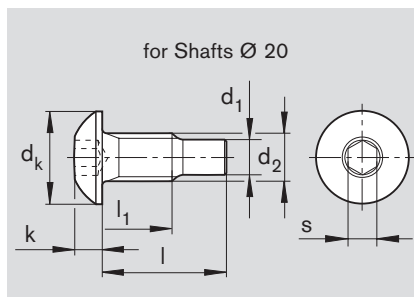

Shaft [mm] Ød	Dimensions [mm]																Locating screw		
	L	K ₂	L ₁	L ₂	L ₃	L ₄	D ₁	D ₂	D ₃	D ₄	d ₂	d _k	d ₁	l	l ₁	k	s	Part numbers	Tightening torque [Nm]
20	25.5 _{-0.1}	0	8.5 ^{+0.2}	6.5	1.3	2.5	3.1	M4	4.5	8	M4	7.6	3	10.15	5.7	2.2	2.5	R3429 009 01	1.9
25	33.05 _{-0.1}	1.5	10 ^{+0.2}	8	2	3.2	3.1	M4	4.5	8	M4	7	3	14.1	6.5	2.8	2.5	R3427 009 09	1.9
30	36 _{-0.15}	2	10 ^{+0.2}	8	2	3.2	3.1	M4	4.5	8	M4	7	3	14.1	6.5	2.8	2.5	R3427 009 09	1.9
40	42.9 _{-0.15}	1.5	10 ^{+0.2}	8	2	3.2	3.1	M4	4.5	8	M4	7	3	14.1	6.5	2.8	2.5	R3427 009 09	1.9
50	58.5 _{-0.2}	2.5	17.5 ^{+0.5}	13.5	3.7	6	5.1	M8	9	15	M8	13	5	22.8	12.5	5	5	R3427 005 09	16
60	71.5 _{-0.25}	2.5	17.5 ^{+0.5}	13.5	3.7	6	5.1	M8	9	15	M8	13	5	29.7	12.5	5	5	R3427 006 09	16
80	85.5 _{-0.25}	2.5	17.5 ^{+0.5}	13.5	3.7	6	5.1	M8	9	15	M8	13	5	29.7	12.5	5	5	R3427 006 09	16

- Axial retention by means of screws and cover plates, rotary retention by means of pin or plates.

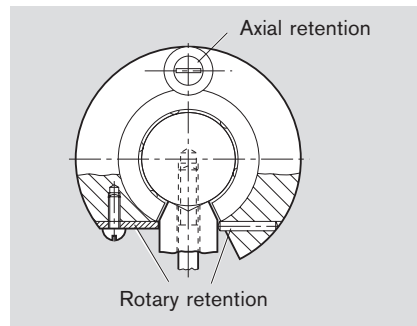

Standard Linear Bushings

Standard Linear Bushings, R0600
closed type, without seal

Standard Linear Bushings, R0602
closed type, with seals

Structural design

- Hardened and ground outer sleeve
- Steel ball retainer (plastic ball retainer in sizes 5 and 8)
- Balls made of anti-friction bearing steel
- Internal steel holding rings or seals
- Closed version, for use on unsupported shafts



Shaft Ø d [mm]	Part numbers		Mass [kg]
	without seal	with two seals	
3	R0600 303 00	–	0.001
4	R0600 304 00	–	0.002
5	R0600 305 00	R0602 305 10	0.010
8	R0600 308 00	R0602 308 10	0.020
10	R0600 310 00	R0602 310 10	0.030
12	R0600 012 00	R0602 012 10	0.040
16	R0600 016 00	R0602 016 10	0.050
20	R0600 020 00	R0602 020 10	0.100
25	R0600 025 00	R0602 025 10	0.190
30	R0600 030 00	R0602 030 10	0.320
40	R0600 040 00	R0602 040 10	0.620
50	R0600 050 00	R0602 050 10	1.140
60	R0600 060 00	R0602 060 10	2.110
80	R0600 080 00	R0602 080 10	4.700

With one seal: R0601 ... 10.

Dimensions

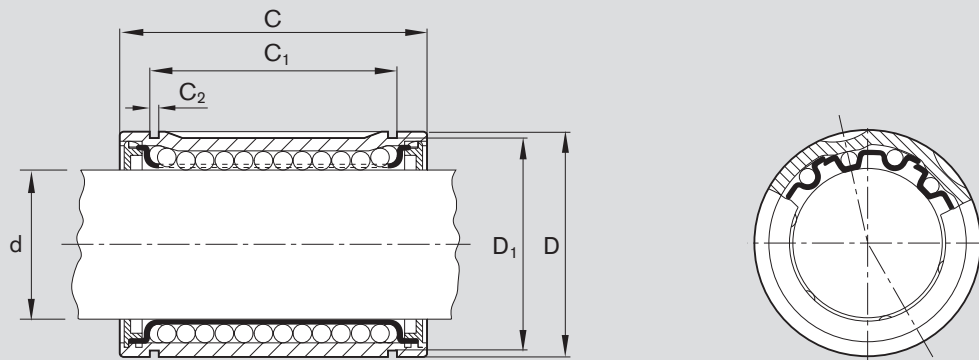

Ø d	Dimensions [mm]					No. of ball circuits	Working bore diameter tolerance [µm]	Radial clearance ¹⁾ [µm]		Load capacities [N]			
	D	C	C ₁	C ₂	D ₁			h6	h7	dyn. C		stat. C ₀	
	h5	h12	H13						min	max	min	max	
3 ²⁾	7 ³⁾	10	-	-	-	4	+8 0	+12 +2	+15 +3	55	65	45	65
4 ²⁾	8 ³⁾	12	-	-	-	4	+8 0	+14 +2	+17 +3	70	80	60	85
5 ²⁾	12	22	14.2	1.1	11.1	4	+11 +1	+16 +4	+20 +4	180	210	140	200
8 ²⁾	16	25	16.2	1.1	14.7	4	+12 +2	+18 +5	+24 +5	320	370	240	330
10 ²⁾	19	29	21.6	1.3	18	4	+8 0	+18 +5	+24 +5	300	350	260	370
12	22	32	22.6	1.3	20.5	4	+12 +2	+20 +5	+26 +6	420	480	280	400
16	26	36	24.6	1.3	24.9	4	+14 +2	+22 +5	+28 +6	580	670	440	620
20	32	45	31.2	1.6	30.5	5	+14 +2	+23 +6	+31 +6	1170	1390	860	1250
25	40	58	43.7	1.85	38.5	5	+16 +2	+25 +6	+32 +7	2080	2480	1560	2280
30	47	68	51.7	1.85	44.5	6	+16 +2	+25 +6	+32 +7	2820	2980	2230	2860
40	62	80	60.3	2.15	58	6	+19 +2	+30 +7	+38 +8	5170	5480	3810	4880
50	75	100	77.3	2.65	71	6	+19 +2	+30 +7	+38 +8	8260	8740	6470	8280
60	90	125	101.3	3.15	85	6	+19 +2	+33 +7	+43 +8	11500	12100	9160	11730
80	120	165	133.3	4.15	114	6	+24 +2	+37 +8	+47 +9	21000	22200	16300	20850

¹⁾ Statistically determined from the working bore diameter and shaft tolerance. Recommended housing bore tolerance: H6 or H7.

²⁾ Sizes 3, 4, 5, 8 and 10 have a plastic ball retainer.

³⁾ Tolerance h6

The figures for dynamic load-carrying capacity have been calculated assuming a nominal travel of 100,000 m. For a nominal travel of 50,000 m, the "C" figures in the table must be multiplied by a factor of 1.26.



Standard Linear Bushings

Standard Linear Bushings, R0600
closed type, without seal
corrosion-resistant

Standard Linear Bushings, R0602
closed type, with seals
corrosion-resistant

Structural design

- Hardened and ground outer sleeve made of corrosion-resistant steel
- Steel ball retainer (plastic ball retainer in sizes 5 and 8)
- Balls made of anti-friction bearing steel
- Internal steel holding rings or seals
- Closed version, for use on unsupported shafts



Shaft Ø d [mm]	Part numbers		Mass [kg]
	without seal	with two seals	
3	R0600 003 30	–	0.001
4	R0600 004 30	–	0.002
5	R0600 005 30	R0602 005 30	0.011
8	R0600 008 30	R0602 008 30	0.022
10	R0600 010 30	R0602 010 30	0.036
12	R0600 012 30	R0602 012 30	0.045
16	R0600 016 30	R0602 016 30	0.060
20	R0600 020 30	R0602 020 30	0.100
25	R0600 025 30	R0602 025 30	0.235
30	R0600 030 30	R0602 030 30	0.360
40	R0600 040 30	R0602 040 30	0.770

Note Corrosion-resistant steel is steel to ISO 683-17 / EN 10088.

Dimensions

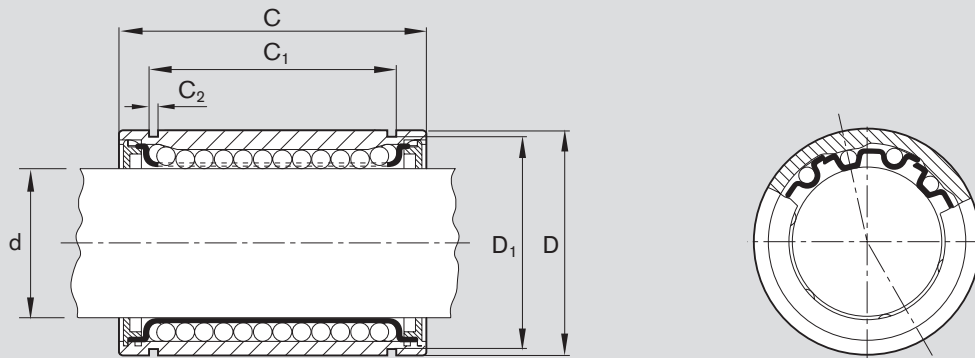

Ø d	Dimensions [mm]					No. of ball circuits	Bore diameter tolerance [µm]	Radial clearance ¹⁾ [µm]		Load capacities [N]			
	D _{h5}	C _{h12}	C _{H13}	C ₂	D ₁			h ₆	h ₇	dyn. C		stat. C ₀	
									min	max	min	max	
3	7 ²⁾	10	-	-	-	4	+8 0	+12 +2	+15 +3	55	65	45	65
4	8 ²⁾	12	-	-	-	4	+8 0	+14 +2	+17 +3	70	80	60	85
5	12	22	14.2	1.1	11.5	4	+11 +1	+16 +4	+20 +4	160	185	180	250
8	16	25	16.2	1.1	15.2	4	+12 +2	+18 +5	+24 +5	210	240	235	330
10	19	29	21.6	1.3	18	4	+8 0	+18 +5	+24 +5	300	350	260	370
12	22	32	22.6	1.3	21	4	+12 +2	+20 +5	+26 +6	400	460	420	600
16	26	36	24.6	1.3	24.9	4	+14 +2	+22 +5	+28 +6	460	530	440	630
20	32	45	31.2	1.6	30.3	5	+14 +2	+23 +6	+31 +6	680	800	860	1250
25	40	58	43.7	1.85	37.5	6	+16 +2	+25 +6	+32 +7	780	830	1620	2100
30	47	68	51.7	1.85	44.5	6	+16 +2	+25 +6	+32 +7	1250	1320	2000	2500
40	62	80	60.3	2.15	59	6	+19 +2	+30 +7	+38 +8	1720	1820	3300	4200

¹⁾ Statistically determined from the working bore diameter and shaft tolerance. Recommended housing bore tolerance: H6 or H7.

²⁾ Tolerance h6

The figures for dynamic load-carrying capacity have been calculated assuming a nominal travel of 100,000 m. For a nominal travel of 50,000 m, the "C" figures in the table must be multiplied by a factor of 1.26.



Standard Linear Bushings

Standard Linear Bushings, R0610
adjustable type, without seal

Standard Linear Bushings, R0612
adjustable type, with seals

Structural design

- Hardened and ground outer sleeve
- Steel ball retainer (plastic ball retainer in sizes 5 and 8)
- Balls made of anti-friction bearing steel
- Internal steel holding rings or seals
- Radial clearance adjustable

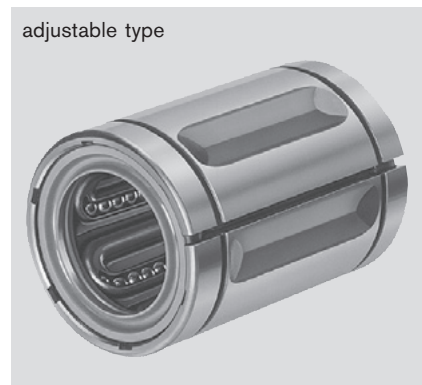

Shaft Ø d [mm]	Part numbers		Mass [kg]
	without seal	with two seals	
5	R0610 305 00	R0612 305 10	0.01
8	R0610 308 00	R0612 308 10	0.02
12	R0610 012 00	R0612 012 10	0.04
16	R0610 016 00	R0612 016 10	0.05
20	R0610 020 00	R0612 020 10	0.10
25	R0610 025 00	R0612 025 10	0.19
30	R0610 030 00	R0612 030 10	0.32
40	R0610 040 00	R0612 040 10	0.62
50	R0610 050 00	R0612 050 10	1.14
60	R0610 060 00	R0612 060 10	2.11
80	R0610 080 00	R0612 080 10	4.70

With one seal: R0611 ... 10.

Dimensions

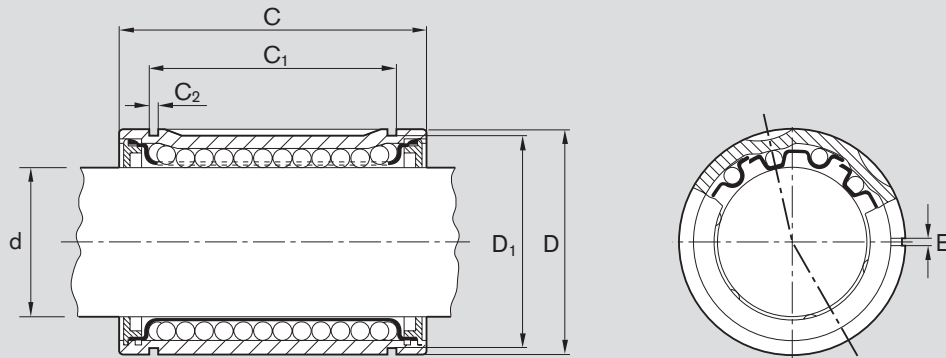

Ø d	Dimensions [mm]						No. of ball circuits	Load capacities [N]				Radial clearance adjustable [shaft/bore] [µm]					
	D ²⁾	C	C ₁	C ₂	D ₁	E		dyn. C		stat. C ₀		h6/H6	h6/HS6	h6/K6	h7/H7	h7/JS7	h7/K7
	h5	h12	H13					min	max	min	max						
5 ¹⁾	12	22	14.2	1.1	11.1	1.5	4	180	210	140	200	+28 +10	+23 +4	+19 +1	+37 +12	+28 +3	+25 0
8 ¹⁾	16	25	16.2	1.1	14.7	1.5	4	320	370	240	330	+31 +11	+25 +6	+22 +2	+41 +14	+32 +5	+29 +2
12	22	32	22.6	1.3	20.5	1.5	4	420	480	280	400	+34 +13	+28 +6	+23 +2	+46 +16	+36 +5	+31 +1
16	26	36	24.6	1.3	24.9	1.5	4	580	670	440	620	+36 +13	+29 +7	+25 +2	+48 +16	+37 +6	+33 +1
20	32	45	31.2	1.6	30.5	2.0	5	1170	1390	860	1250	+41 +15	+33 +7	+28 +2	+55 +18	+42 +6	+37 0
25	40	58	43.7	1.85	38.5	2.0	5	2080	2480	1560	2280	+43 +15	+35 +7	+30 +2	+56 +19	+44 +6	+38 +1
30	47	68	51.7	1.85	44.5	2.0	6	2820	2980	2230	2860	+43 +15	+35 +7	+30 +2	+56 +19	+44 +6	+38 +1
40	62	80	60.3	2.15	58	2.0	6	5170	5480	3810	4880	+51 +18	+41 +9	+36 +3	+67 +22	+52 +7	+46 +1
50	75	100	77.3	2.65	71	2.0	6	8260	8740	6470	8280	+51 +18	+41 +9	+36 +3	+67 +22	+52 +7	+46 +1
60	90	125	101.3	3.15	85	2.0	6	11500	12100	9160	11730	+57 +20	+46 +9	+39 +2	+76 +25	+59 +7	+51 0
80	120	165	133.3	4.15	114	2.0	6	21000	22200	16300	20850	+61 +21	+50 +10	+43 +3	+80 +26	+62 +9	+55 +1

¹⁾ Sizes 5 and 8 have a plastic ball retainer.

²⁾ Tolerances valid for this diameter before the bushing housing is slotted.

The figures for dynamic load-carrying capacity have been calculated assuming a nominal travel of 100,000 m. For a nominal travel of 50,000 m, the "C" figures in the table must be multiplied by a factor of 1.26.



Standard Linear Bushings

Standard Linear Bushings, R0630
open type, without seal

Standard Linear Bushings, R0632
open type, with seals

Structural design

- Hardened and ground outer sleeve
- Steel ball retainer (plastic ball retainer in sizes 5 and 8)
- Balls made of anti-friction bearing steel
- Internal steel holding rings or seals
- With bore for axial and radial retention (except sizes 12 and 16)

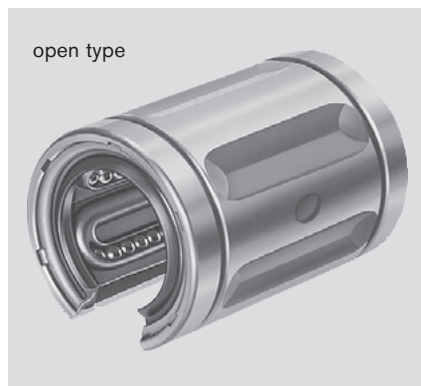
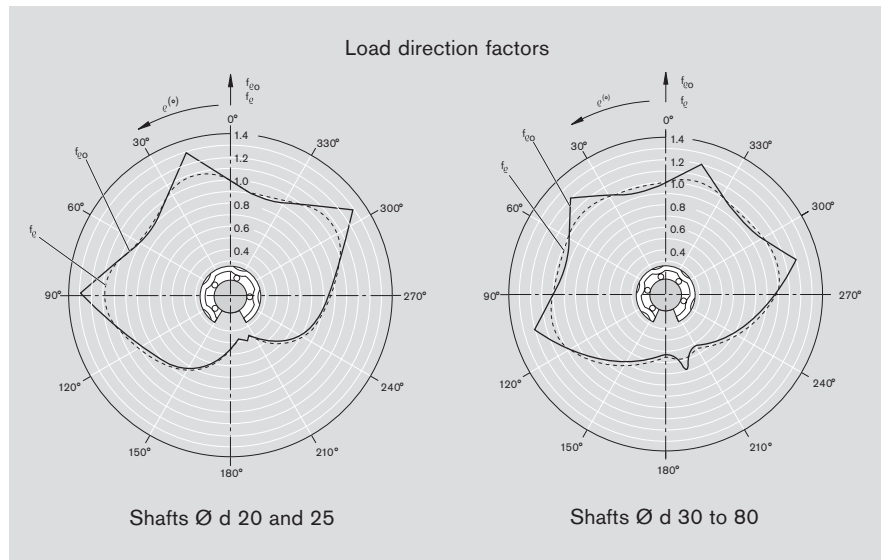

Shaft Ø d [mm]	Part numbers			Mass [kg]
	without seal	with two seals	fully sealed	
12 ¹⁾	R0630 012 00	R0632 012 00	–	0.03
16 ¹⁾	R0630 016 00	R0632 016 00	–	0.04
20	R0630 020 00	R0632 020 00	R0632 020 05	0.08
25	R0630 025 00	R0632 025 00	R0632 025 05	0.15
30	R0630 030 00	R0632 030 00	R0632 030 05	0.26
40	R0630 040 00	R0632 040 00	R0632 040 05	0.52
50	R0630 050 00	R0632 050 00	R0632 050 05	0.95
60	R0630 060 00	R0632 060 00	R0632 060 05	1.76
80	R0630 080 00	R0632 080 00	R0632 080 05	3.92

¹⁾ Without bore for axial and radial retention.

With one seal: R0631 0.. 00

Dimensions

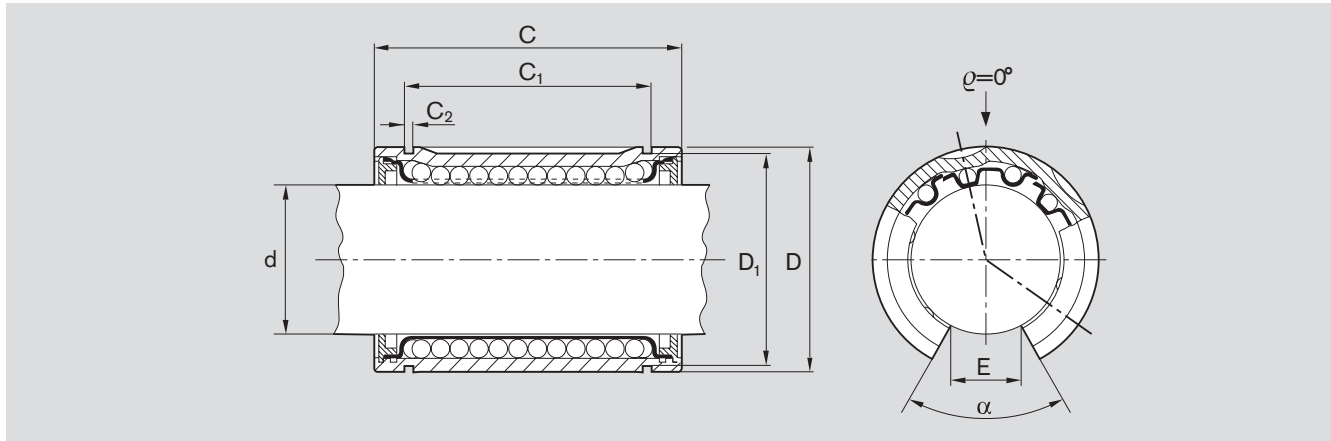

Ø d	Dimensions [mm]						Angle [°] α	No. of ball circuits	Load capacities ³⁾		Radial clearance adjustable [μm] (Shaft/Bore)					
	D ¹⁾ h5	C h12	C ₁ H13	C ₂	D ₁	E ²⁾			dyn. C [N]	stat. C ₀	h6/H6	h6/HS6	h6/K6	h7/H7	h7/JS7	h7/K7
12	22	32	22.6	1.3	20.5	7.5	78	3	430	290	+34 +13	+28 +6	+23 +2	+46 +16	+36 +5	+31 +1
16	26	36	24.6	1.3	24.9	10.0	78	3	600	450	+36 +13	+29 +7	+25 +2	+48 +16	+37 +6	+33 +1
20	32	45	31.2	1.6	30.5	10.0	60	4	1280	970	+41 +15	+33 +7	+28 +2	+55 +18	+42 +6	+37 0
25	40	58	43.7	1.85	38.5	12.5	60	4	2270	1750	+43 +15	+35 +7	+30 +2	+56 +19	+44 +6	+38 +1
30	47	68	51.7	1.85	44.5	12.5	50	5	2890	2390	+43 +15	+35 +7	+30 +2	+56 +19	+44 +6	+38 +1
40	62	80	60.3	2.15	58	16.8	50	5	5280	4000	+51 +18	+41 +9	+36 +3	+67 +22	+52 +7	+46 +1
50	75	100	77.3	2.65	71	21.0	50	5	8470	6900	+51 +18	+41 +9	+36 +3	+67 +22	+52 +7	+46 +1
60	90	125	101.3	3.15	85	27.2	54	5	11800	9780	+57 +20	+46 +9	+39 +2	+76 +25	+59 +7	+51 0
80	120	165	133.3	4.15	114	36.3	54	5	21500	17400	+61 +21	+50 +10	+43 +3	+80 +26	+62 +9	+55 +1

¹⁾ The tolerance stated is valid for the Linear Bushing in the unslotted condition.

²⁾ Minimum dimension based on shaft diameter d.

³⁾ The load capacities C and C₀ apply only when the load is acting along the line $\rho = 0^\circ$.

If the load is acting in any other direction, these load capacities must be multiplied by the factor f_ρ or f_{ρ_0} .

For loads acting on the opening in sizes 12 and 16:
 $\rho = 180^\circ$
 $f_\rho = 0.37$

The figures for dynamic load-carrying capacity have been calculated assuming a nominal travel of 100,000 m.
 For a nominal travel of 50,000 m, the "C" figures in the table must be multiplied by a factor of 1.26.

Sizes 12 and 16 must be mounted as shown here (mirror-symmetrically) to prevent their lifting from the shaft. It is not possible to adjust a single linear bushing (with slotted housing adjustable by means of an adjusting screw) to zero clearance.

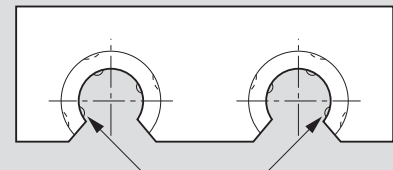

Standard Linear Bushings

Standard Linear Bushings, R0650
Tandem, with seals
normal

Structural design

- Hardened and ground outer sleeve
- Plastic ball retainer
- Balls made of anti-friction bearing steel
- Internal seals

Standard Linear Bushings, R0650
Tandem, with seals
corrosion-resistant

Structural design

- Hardened and ground outer sleeve made of corrosion-resistant steel
- Ball retainer made of corrosion-resistant steel
- Balls made of corrosion-resistant anti-friction bearing steel
- Internal Seals



Shaft Ø d [mm]	Part numbers		Mass [kg]
	normal	corrosion-resistant	
8	R0650 508 00	R0650 208 30	0.04
12	R0650 512 00	R0650 212 30	0.08
16	R0650 516 00	R0650 216 30	0.12
20	R0650 520 00	R0650 220 30	0.18
25	R0650 525 00	R0650 225 30	0.43
30	R0650 530 00	R0650 230 30	0.62
40	R0650 540 00	R0650 240 30	1.40

Note: Corrosion-resistant steel is steel to ISO 683-17 / EN 10088.

Dimensions

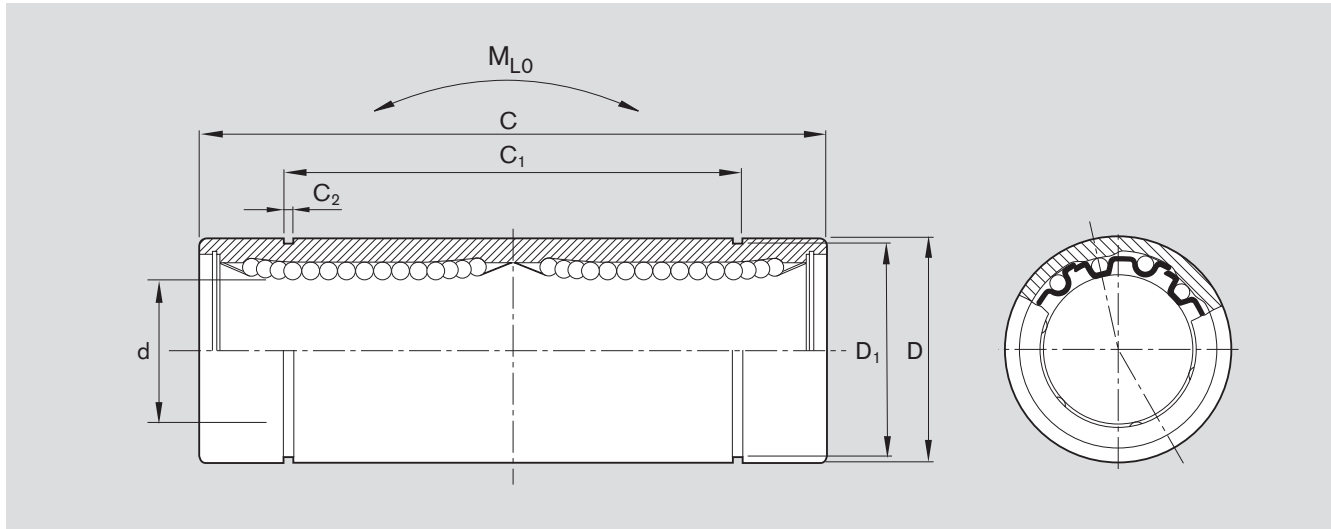

Ø d	D h6	Dimensions [mm]				No. of ball circuits	Bore diameter tolerance [µm]	Radial clearance ¹⁾ [µm]		Load capacities [N]				Tipping Moment M_{L0} stat. [Nm]
		C	C ₁	C ₂	D ₁			h6	h7	dyn. C		stat. C ₀		
		min	max	min	max					min	max	min	max	
8	16	46 _{-0.3}	33 _{-0.3}	1.10	15.2	4	+9 -1	+15 +2	+21 +2	340	390	470	660	4.5
12	22	61 _{-0.3}	45.8 _{-0.3}	1.30	21.0	4	+9 -1	+17 +2	+23 +3	650	750	840	1200	11
16	26	68 _{-0.3}	49.8 _{-0.3}	1.30	24.9	4	+11 -1	+19 +2	+25 +3	750	860	880	1260	13
20	32	80 _{-0.3}	61 _{-0.3}	1.60	30.5	5	+11 -1	+20 +3	+28 +3	1100	1300	1720	2500	26
25	40	112 _{-0.4}	82 _{-0.4}	1.85	38.0	6	+13 -2	+22 +2	+29 +3	1250	1350	3240	4200	61
30	47	123 _{-0.4}	104.2 _{-0.4}	1.85	44.5	6	+13 -2	+22 +2	+29 +3	2000	2150	4000	5000	82
40	62	151 _{-0.4}	121.2 _{-0.4}	2.15	59.0	6	+16 -4	+27 +1	+35 +2	2800	3000	6600	8400	165

¹⁾ Statistically determined from the working bore diameter and shaft tolerance. Recommended housing bore tolerance: H6 or H7.

The figures for dynamic load-carrying capacity have been calculated assuming a nominal travel of 100,000 m. For a nominal travel of 50,000 m, the "C" figures in the table must be multiplied by a factor of 1.26.



Standard Linear Bushings

Standard Linear Bushings, R0740
Flanged type
normal

Structural design

- Hardened and ground outer sleeve
- Plastic ball retainer
- Balls made of anti-friction bearing steel
- Internal seals

Standard Linear Bushings, R0740
Flanged type
corrosion-resistant

Structural design

- Hardened and ground outer sleeve made of corrosion-resistant steel
- Ball retainer made of corrosion-resistant steel (Size 5 with plastic ball retainer)
- Balls made of corrosion-resistant anti-friction bearing steel
- Internal Seals



Shaft Ø d [mm]	Part numbers		Mass [kg]
	normal	corrosion-resistant	
5	R0740 505 00	R0740 505 30	0.020
8	R0740 508 00	R0740 208 30	0.033
12	R0740 512 00	R0740 212 30	0.064
16	R0740 516 00	R0740 216 30	0.090
20	R0740 520 00	R0740 220 30	0.150
25	R0740 525 00	R0740 225 30	0.300
30	R0740 530 00	R0740 230 30	0.470
40	R0740 540 00	R0740 240 30	0.980

Note: Corrosion-resistant steel is steel to ISO 683-17 / EN 10088.

Dimensions

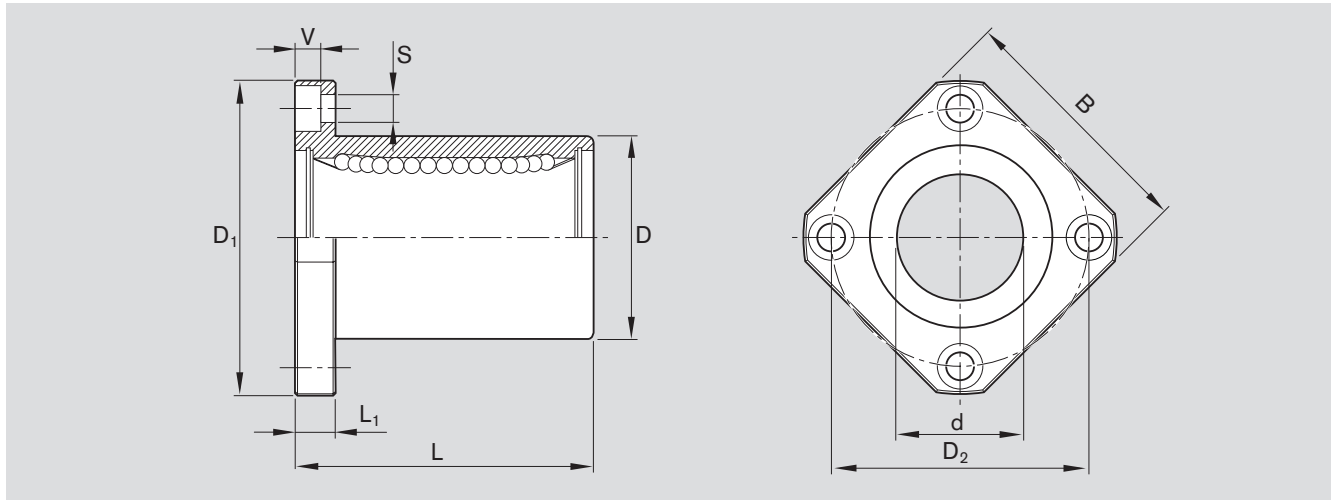

Ø d	Dimensions [mm]								No. of ball circuits	Bore diameter tolerance [µm]	Radial clearance ¹⁾ [µm]		Load capacities [N]			
	D	D ₁	D ₂	B	L	L ₁	V	S			h6	h7	dyn. C		stat. C ₀	
					±0.3							min	max	min	max	
5	12 _{-0.013}	28	20	22	22	5	3.1	3.5	4	+8 +0	+14 +2	+17 +3	160	185	180	250
8	16 _{-0.013}	32	24	25	25	5	3.1	3.5	4	+8 +0	+15 +2	+20 +3	210	240	235	330
12	22 _{-0.016}	42	32	32	32	6	4.1	4.5	4	+8 +0	+16 +3	+23 +3	400	460	420	600
16	26 _{-0.016}	46	36	35	36	6	4.1	4.5	4	+9 -1	+17 +2	+23 +3	460	530	440	630
20	32 _{-0.019}	54	43	42	45	8	5.1	5.5	5	+9 -1	+19 +2	+26 +3	680	800	860	1250
25	40 _{-0.019}	62	51	50	58	8	5.1	5.5	6	+11 -1	+20 +3	+28 +3	780	830	1620	2100
30	47 _{-0.019}	76	62	60	68	10	6.1	6.6	6	+11 -1	+20 +3	+28 +3	1250	1320	2000	2500
40	62 _{-0.022}	98	80	75	80	13	8.1	9	6	+13 -2	+24 +3	+33 +3	1720	1820	3300	4200

¹⁾ Statistically determined from the working bore diameter and shaft tolerance. Recommended housing bore tolerance: H6 or H7.

The figures for dynamic load-carrying capacity have been calculated assuming a nominal travel of 100,000 m. For a nominal travel of 50,000 m, the "C" figures in the table must be multiplied by a factor of 1.26.



Standard Linear Bushings

Standard Linear Bushings, R0741
Flanged-tandem
normal

Structural design

- Hardened and ground outer sleeve
- Plastic ball retainer
- Balls made of anti-friction bearing steel
- Internal seals

Standard Linear Bushings, R0741
Flanged-tandem
corrosion-resistant

Structural design

- Hardened and ground outer sleeve made of corrosion-resistant steel
- Ball retainer made of corrosion-resistant steel
- Balls made of corrosion-resistant anti-friction bearing steel
- Internal Seals



Shaft Ø d [mm]	Part numbers		Mass [kg]
	normal	corrosion-resistant	
8	R0741 508 00	R0741 208 30	0.05
12	R0741 512 00	R0741 212 30	0.09
16	R0741 516 00	R0741 216 30	0.14
20	R0741 520 00	R0741 220 30	0.23
25	R0741 525 00	R0741 225 30	0.50
30	R0741 530 00	R0741 230 30	0.72
40	R0741 540 00	R0741 240 30	1.60

Note: Corrosion-resistant steel is steel to ISO 683-17 / EN 10088.

Dimensions

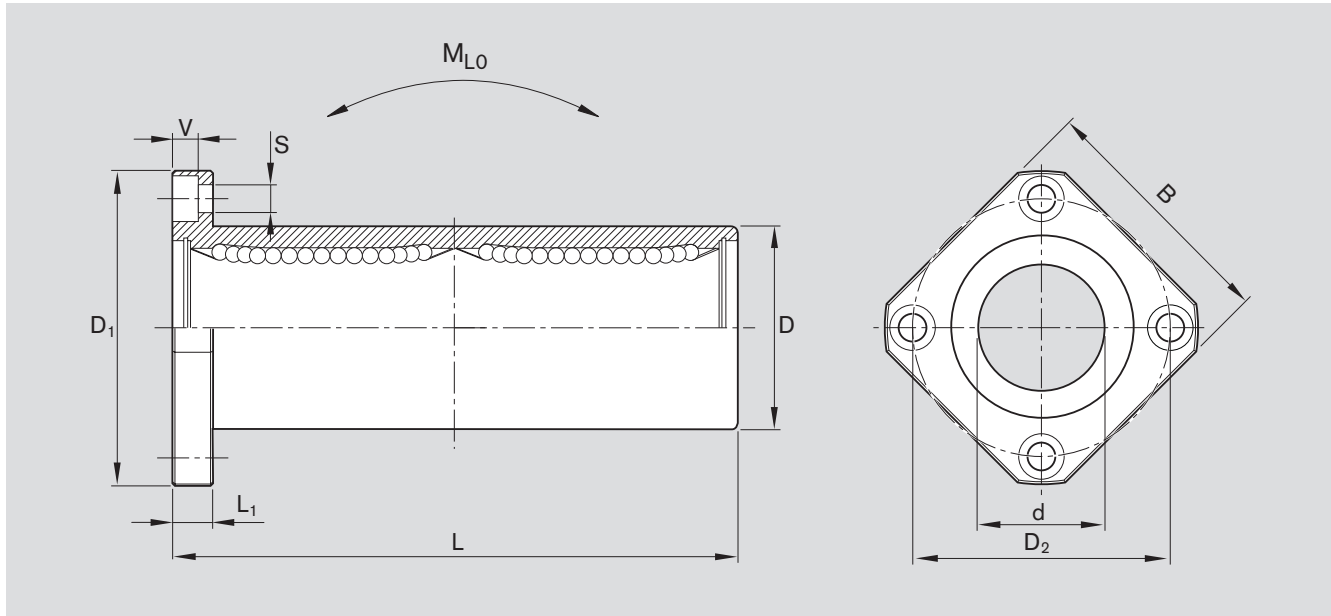

$\varnothing d$	Dimensions [mm]									No. of ball circuits	Bore diameter tolerance [μm]		Radial clearance ¹ [μm]		Load capacities [N]				Tipping Moment M_{L0} stat. [Nm]
	D	D_1	D_2	B	L	L_1	V	S	± 0.3		$h6$	$h7$	dyn. C min	dyn. C max	stat. C_0 min	stat. C_0 max			
8	16 _{-0.013}	32	24	25	46	5	3.1	3.5	4	+9 -1	+15 +21 +2 +2	340	390	470	660	4.5			
12	22 _{-0.016}	42	32	32	61	6	4.1	4.5	4	+9 -1	+17 +23 +2 +3	650	750	840	1200	11			
16	26 _{-0.016}	46	36	35	68	6	4.1	4.5	4	+11 -1	+19 +25 +2 +3	750	860	880	1260	13			
20	32 _{-0.019}	54	43	42	80	8	5.1	5.5	5	+11 -1	+20 +28 +3 +3	1100	1300	1720	2500	26			
25	40 _{-0.019}	62	51	50	112	8	5.1	5.5	6	+13 -2	+22 +29 +2 +3	1250	1350	3240	4200	61			
30	47 _{-0.019}	76	62	60	123	10	6.1	6.6	6	+13 -2	+22 +29 +2 +3	2000	2150	4000	5000	82			
40	62 _{-0.022}	98	80	75	151	13	8.1	9	6	+16 -4	+27 +35 +1 +2	2800	3000	6600	8400	165			

¹⁾ Statistically determined from the working bore diameter and shaft tolerance. Recommended housing bore tolerance: H6 or H7.

The figures for dynamic load-carrying capacity have been calculated assuming a nominal travel of 100,000 m. For a nominal travel of 50,000 m, the "C" figures in the table must be multiplied by a factor of 1.26.



Standard Linear Bushings

Standard Linear Bushings, R0742
Middle flanged
normal

Structural design

- Hardened and ground outer sleeve
- Plastic ball retainer
- Balls made of anti-friction bearing steel
- Internal seals

Standard Linear Bushings, R0742
Middle flanged
corrosion-resistant

Structural design

- Hardened and ground outer sleeve made of corrosion-resistant steel
- Ball retainer made of corrosion-resistant steel
- Balls made of corrosion-resistant anti-friction bearing steel
- Internal Seals



Shaft Ø d [mm]	Part numbers		Mass [kg]
	normal	corrosion-resistant	
8	R0742 508 00	R0742 208 30	0.05
12	R0742 512 00	R0742 212 30	0.09
16	R0742 516 00	R0742 216 30	0.14
20	R0742 520 00	R0742 220 30	0.23
25	R0742 525 00	R0742 225 30	0.50
30	R0742 530 00	R0742 230 30	0.72
40	R0742 540 00	R0742 240 30	1.60

Note: Corrosion-resistant steels are steels to SO 683-17 / EN 10088.

Dimensions

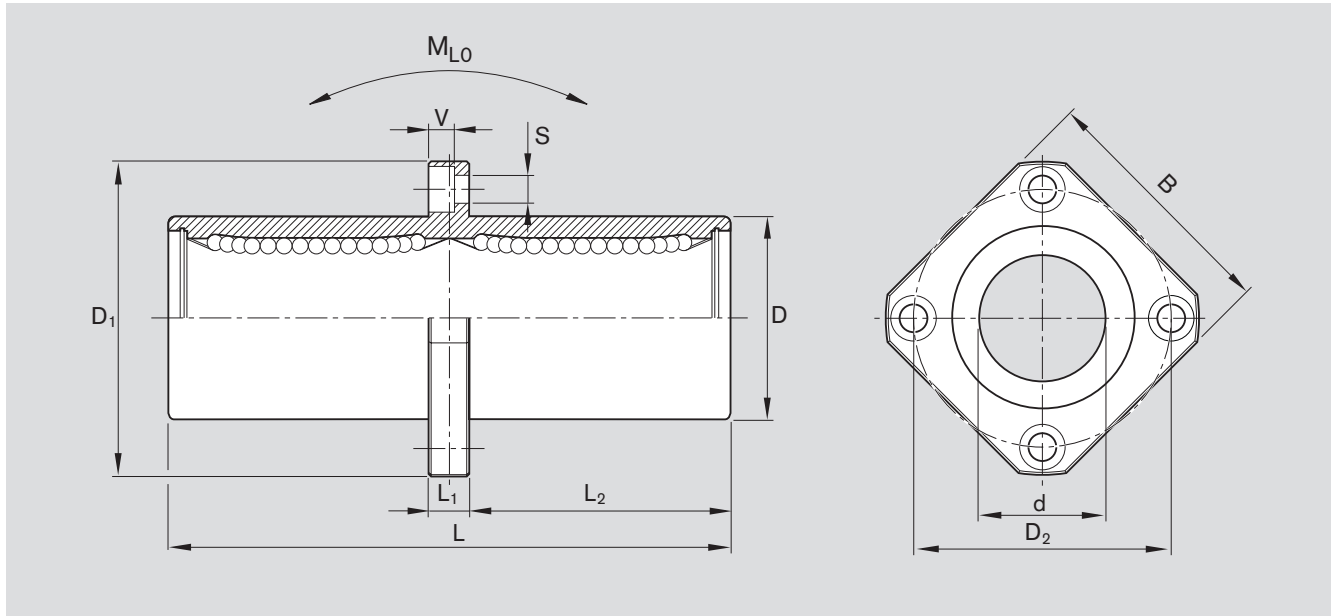

Ø d	Dimensions [mm]										No. of ball circuits	Bore diameter tolerance [µm]	Radial clearance ¹⁾ [µm]		Load capacities [N]				Tipping Moment M _{Lo} stat. [Nm]
	D	D ₁	D ₂	B	L	L ₁	L ₂	V	S	h6			h7	dyn. C		stat. C ₀			
					±0.3									min	max	min	max		
8	16 _{-0.013}	32	24	25	46	5	20.5	3.1	3.5	4	+9 -1	+15 +2	+21 +2	340	390	470	660	4.5	
12	22 _{-0.016}	42	32	32	61	6	27.5	4.1	4.5	4	+9 -1	+17 +2	+23 +3	650	750	840	1200	11	
16	26 _{-0.016}	46	36	35	68	6	31.0	4.1	4.5	4	+11 -1	+19 +2	+25 +3	750	860	880	1260	13	
20	32 _{-0.019}	54	43	42	80	8	36.0	5.1	5.5	5	+11 -1	+20 +3	+28 +3	1100	1300	1720	2500	26	
25	40 _{-0.019}	62	51	50	112	8	52.0	5.1	5.5	6	+13 -2	+22 +2	+29 +3	1250	1350	3240	4200	61	
30	47 _{-0.019}	76	62	60	123	10	56.5	6.1	6.6	6	+13 -2	+22 +2	+29 +3	2000	2150	4000	5000	82	
40	62 _{-0.022}	98	80	75	151	13	69.0	8.1	9	6	+16 -4	+27 +1	+35 +2	2800	3000	6600	8400	165	

¹⁾ Statistically determined from the working bore diameter and shaft tolerance. Recommended housing bore tolerance: H6 or H7.

The figures for dynamic load-carrying capacity have been calculated assuming a nominal travel of 100,000 m. For a nominal travel of 50,000 m, the "C" figures in the table must be multiplied by a factor of 1.26.



Linear Sets with Standard Linear Bushings

Overview

Linear Sets

Closed type

Standard type with fixed working bore diameter.

Adjustable type

For use when zero clearance or preload is required.

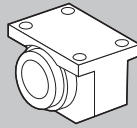

R1065 ...

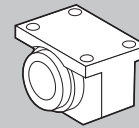

R1066 ...

Open type

For long guideways when the shafts must be supported and high rigidity is required.

Open type, adjustable

For use when zero clearance or preload is required.

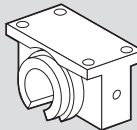

R1067 ...

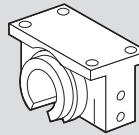

R1068 ...

With side opening

The load carrying capacity of open linear bushings is reduced when the load is applied to the "open" portion of the bushing. The Linear Set with side opening has been developed to overcome this disadvantage and to permit selective circumferential positioning of the open linear bushing.

With side opening, adjustable
For use when zero-clearance or preload is required.

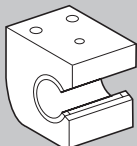

R1073 ...

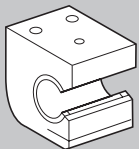

R1074 ...

Flanged type

This element was developed as a complement to our Linear Set series for use in applications requiring the shaft to be arranged at right angles to the mounting base.

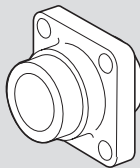

R1081 ...

Advantages/Technical Data/Notes for Mounting

Advantages

- Thanks to their special material and sturdy wall thickness, precision housings offer very high rigidity regardless of the direction of loading, even when the load carrying capacity of the assembly is exploited to the full.
- The housings are easy to align during mounting, so that no adverse stress is exerted on the linear bushing.
- Their high precision guarantees trouble-free running of our linear bushings and full interchangeability of all units.
- Since our housings are produced in large numbers, they offer the same high quality as the user's own design at a price that no in-house design can match for economy.

Technical data

Operating temperatures

-20 °C to 80 °C, with brief peaks up to 100 °C

Notes for mounting

Radial clearance

The radial clearance values given in the tables have been obtained by statistical methods and are representative of the values to be expected in actual practice. The Linear Sets R1066, R1068 and R1074 are adjusted to zero clearance on a shaft of diameter accurate to a tolerance of h5 (lower limit) before leaving the factory.

Vertical dimensions

The tables for Linear Sets contain tolerance values for the height dimension 'H'. These tolerance values have been obtained by statistical methods and are representative of the values to be expected in actual practice.

Screws

We recommend screws to ISO 4762-8.8 for mounting Linear Sets.



Linear Sets with Standard Linear Bushings

Linear Sets, R1065
closed typeLinear Sets, R1066
adjustable type

Structural design

- Precision Housing (lamellar graphite cast iron)
- Standard Linear Bushings with seals
- Two retaining rings



Shaft Ø d [mm]	Part numbers with two seals	Mass [kg]
8	R1065 208 00	0.09
12	R1065 212 00	0.16
16	R1065 216 00	0.27
20	R1065 220 00	0.45
25	R1065 225 00	0.89
30	R1065 230 00	1.33
40	R1065 240 00	2.51
50	R1065 250 00	3.68
60	R1065 260 00	6.73
80	R1065 280 00	15.32



Shaft Ø d [mm]	Part numbers with two seals	Mass [kg]
8	R1066 208 00	0.09
12	R1066 212 00	0.16
16	R1066 216 00	0.27
20	R1066 220 00	0.45
25	R1066 225 00	0.89
30	R1066 230 00	1.33
40	R1066 240 00	2.51
50	R1066 250 00	3.68
60	R1066 260 00	6.73
80	R1066 280 00	15.32

The figures for dynamic load-carrying capacity have been calculated assuming a nominal travel of 100,000 m. For a nominal travel of 50,000 m, the "C" figures in the table must be multiplied by a factor of 1.26.

Dimensions

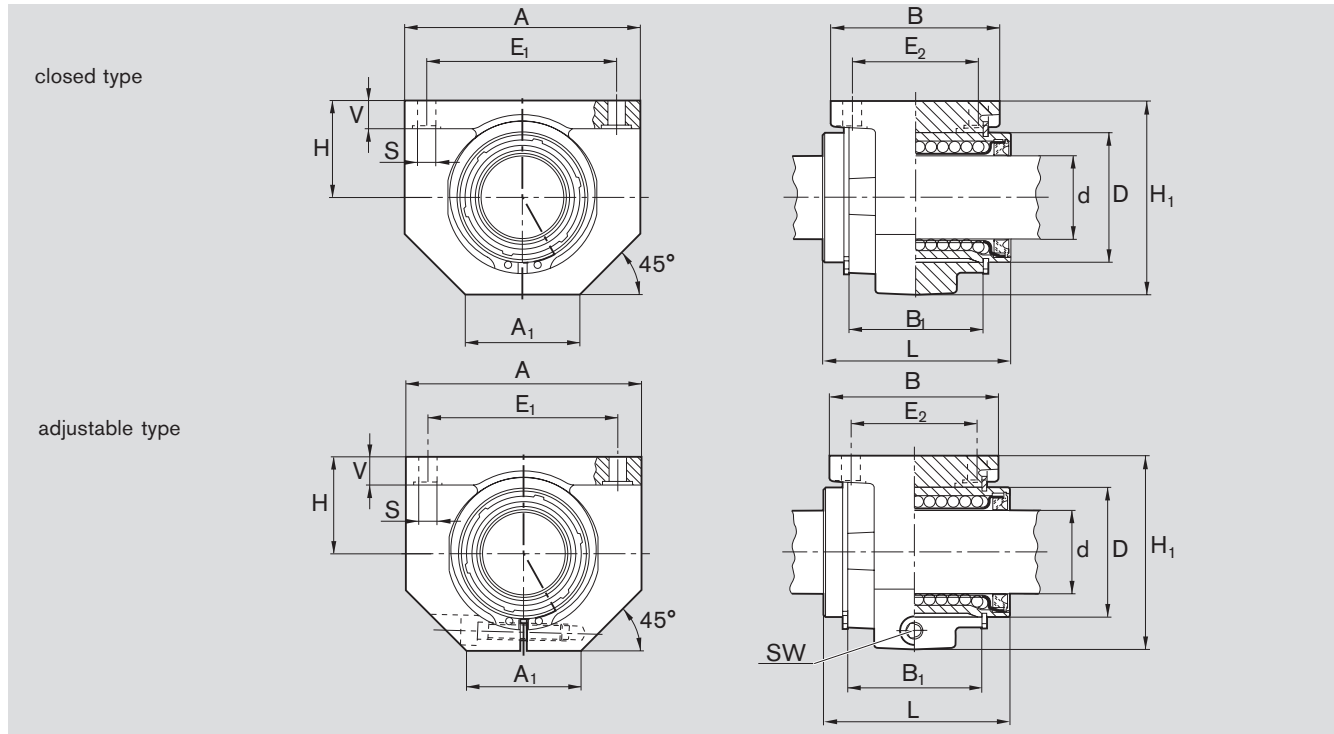

Dimensions [mm]														Radial clearance ²⁾ [μm]		Tolerance [μm] for Dimension H ³⁾	Load capacities ⁴⁾ [N]	
Ø d	D	H	H ₁ ¹⁾	L	A ¹⁾	A ₁ ¹⁾	B ¹⁾	B ₁	E ₁	E ₂	S	V ¹⁾	SW	R1065 with Shaft h6 h7	R1066		dyn. C	stat. C ₀
8	16	15	28	25	32	16	28	14	25±0.15	20±0.15	3.4	5	2	+18 +24	+5 +5	+6	320	240
12	22	18	35	32	42	21	32	20	32±0.15	23±0.15	4.5	5.5	2.5	+20 +26	+5 +6	+6	420	280
16	26	22	42	36	50	26	35	22	40±0.15	26±0.15	4.5	6.5	3	+22 +28	+5 +6	+5	580	440
20	32	25	50	45	60	28	42	28	45±0.15	32±0.15	4.5	8	3	+23 +31	+6 +6	-18	1170	860
25	40	30	60	58	74	38	54	40	60±0.15	40±0.15	5.5	9	5	+25 +32	+6 +7	+5	2080	1560
30	47	35	70	68	84	41	60	48	68±0.20	45±0.20	6.6	10	5	+25 +32	+6 +7	-19	2820	2230
40	62	45	90	80	108	51	78	56	86±0.20	58±0.20	9	12	6	+30 +38	+7 +8	+4	5170	3810
50	75	50	105	100	130	57	70	72	108±0.20	50±0.20	9	14	8	+30 +38	+7 +8	-21	8260	6470
60	90	60	125	125	160	70	92	95	132±0.25	65±0.25	11	15	10	+33 +43	+7 +8	+8	11500	9160
80	120	80	170	165	200	85	122	125	170±0.50	90±0.50	13.5	22	14	+37 +47	+8 +9	-26	21000	16300
																+7		
																-28		

¹⁾ Tolerance DIN 1686-GTB 15.

²⁾ Statistically determined from the working bore diameter and shaft tolerances. Taking the Linear Bushing outer diameter and the housing bore into consideration, the radial clearance values for shaft h7 are similar to those given for the Standard Linear Bushing R0610 in the h7/H7 column under the heading "Adjustable radial clearance"

³⁾ Minimum dimension based on shaft diameter d.

⁴⁾ The load capacities stated are minimal values as the position and direction of load cannot always be precisely defined.

Linear Sets with Standard Linear Bushings

Linear Sets, R1067
open type

Linear Sets, R1068
open type, adjustable

Structural design

- Precision housing (spheroidal graphite cast iron)
- Retention by means of locating screw
- Standard Linear Bushings with seals

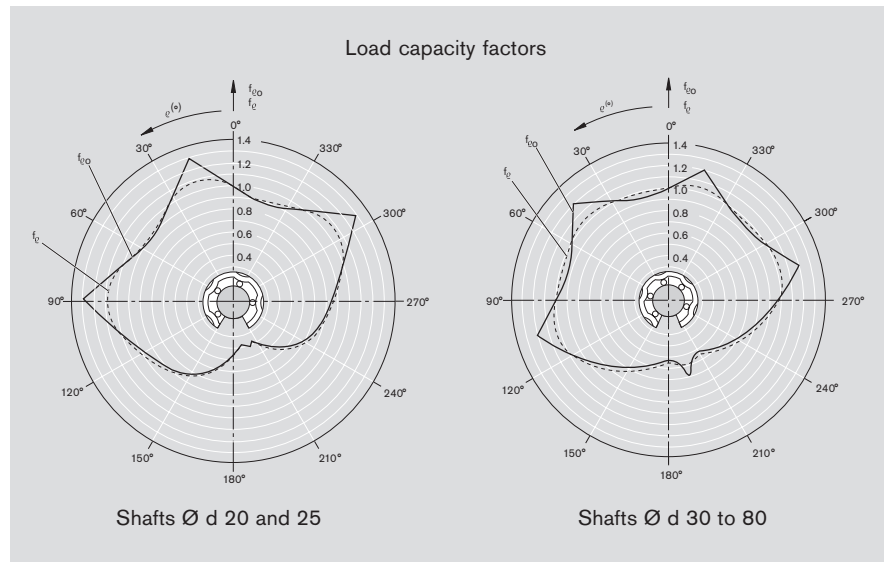

Shaft \varnothing d [mm]	Part numbers with two seals	Mass [kg]
20	R1067 220 00	0.39
25	R1067 225 00	0.74
30	R1067 230 00	1.14
40	R1067 240 00	2.25
50	R1067 250 00	3.13
60	R1067 260 00	5.78
80	R1067 280 00	13.15



Shaft \varnothing d [mm]	Part numbers with two seals	Mass [kg]
20	R1068 220 00	0.38
25	R1068 225 00	0.74
30	R1068 230 00	1.12
40	R1068 240 00	2.20
50	R1068 250 00	3.11
60	R1068 260 00	5.72
80	R1068 280 00	13.09

Dimensions

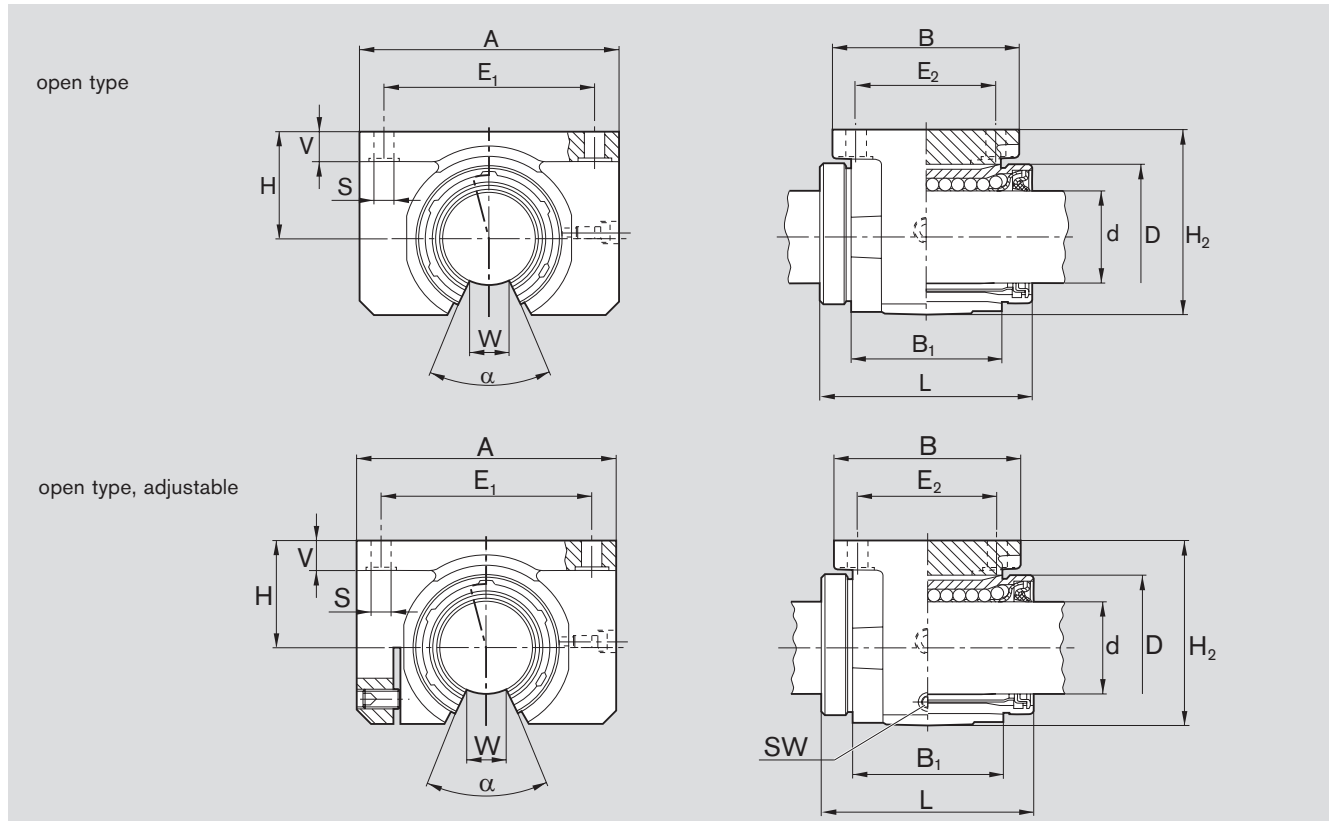

Dimensions [mm]														Angle [°]	Radial clearance [μm] R1067 R1068 with Shaft h6 h7		Tolerance [μm] for dimension H ⁴⁾	Load capacities ⁵⁾ [N] dyn. C stat. C ₀	
Ø d	D	H	H ₂ ²⁾	L	A ²⁾	B ²⁾	B ₁	E ₁	E ₂	S	V ²⁾	W ³⁾	SW	α					
20 ¹⁾	32	25	42	45	60	42	28	45±0.15	32±0.15	4.5	8	10	2.5	60	+36	+42	+5	1280	970
25 ¹⁾	40	30	51	58	74	54	40	60±0.15	40±0.15	5.5	9	12.5	3	60	+38	+44	+5	2270	1750
30	47	35	60	68	84	60	48	68±0.20	45±0.20	6.6	10	12.5	3	50	+38	+44	+5	2890	2390
40	62	45	77	80	108	78	56	86±0.20	58±0.20	9	12	16.8	4	50	+45	+52	+4	5280	4000
50	75	50	88	100	130	70	72	108±0.20	50±0.20	9	14	21	5	50	+45	+52	-21	8470	6900
60	90	60	105	125	160	92	95	132±0.25	65±0.25	11	15	27.2	6	54	+50	+59	+8	11800	9780
80	120	80	140	165	200	122	125	170±0.50	90±0.25	13.5	22	36.3	8	54	+54	+62	+7	21500	17400
															+6	+9	-28		

¹⁾ Contrary to the illustration, the locating screw is on the adjusting side in these sizes.

²⁾ Tolerance DIN 1685-GTB 15.

³⁾ Minimum dimension based on shaft diameter d.

⁴⁾ When screwed down, relative to shaft nominal dimension d.

⁵⁾ The load capacities apply when the load is acting along the line $\varrho = 0^\circ$.

The figures for dynamic load-carrying capacity have been calculated assuming a nominal travel of 100,000 m. For a nominal travel of 50,000 m, the "C" figures in the table must be multiplied by a factor of 1.26.

Linear Sets with Standard Linear Bushings

Linear Sets, R1073
with side opening

Linear Sets, R1074
with side opening, adjustable

Structural design

- Housing with side opening (spheroidal graphite cast iron)
- Retention by means of grooved taper pin
- Standard Linear Bushing
- External seals

The load carrying capacity of open Linear Bushings is considerably reduced when the load is applied to the "open" portion of the bushing. The Linear Set with side opening has been developed to overcome this disadvantage and to permit selective circumferential positioning of the open Linear Bushing.

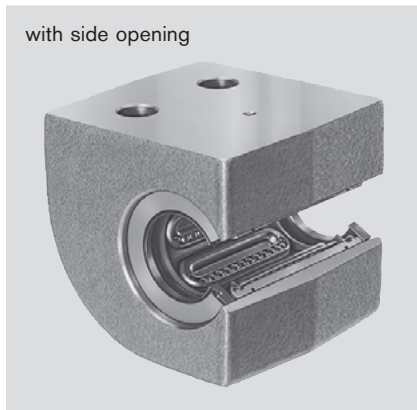
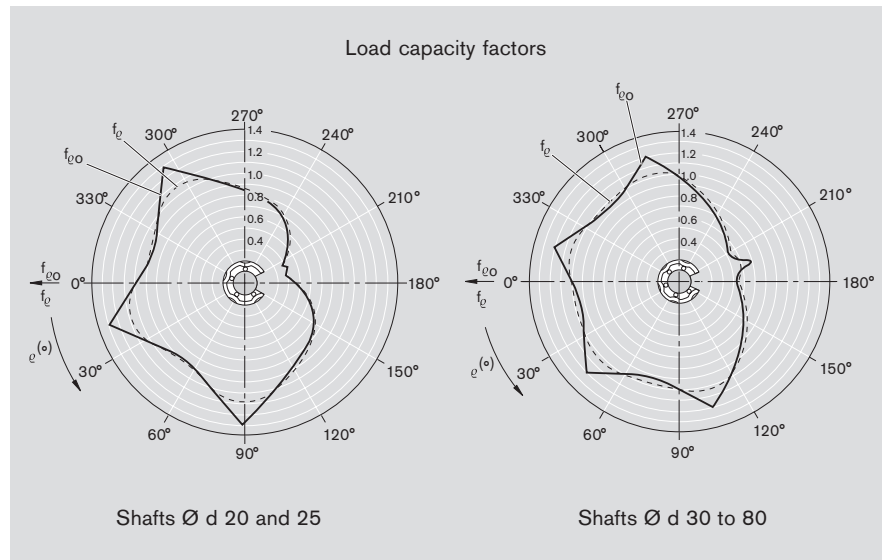

Shaft Ø d [mm]	Part numbers with two seals	Mass [kg]
20	R1073 220 00	1.0
25	R1073 225 00	1.9
30	R1073 230 00	2.8
40	R1073 240 00	4.8
50	R1073 250 00	8.0

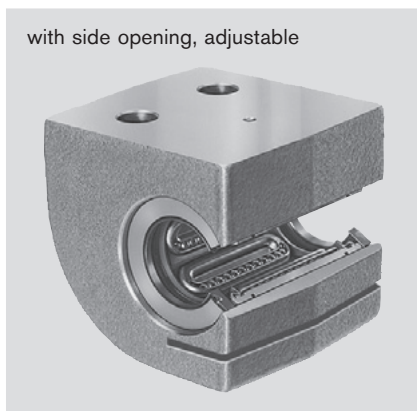

Shaft Ø d [mm]	Part numbers with two seals	Mass [kg]
20	R1074 220 00	1.0
25	R1074 225 00	1.9
30	R1074 230 00	2.8
40	R1074 240 00	4.8
50	R1074 250 00	8.0

Dimensions

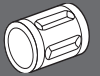
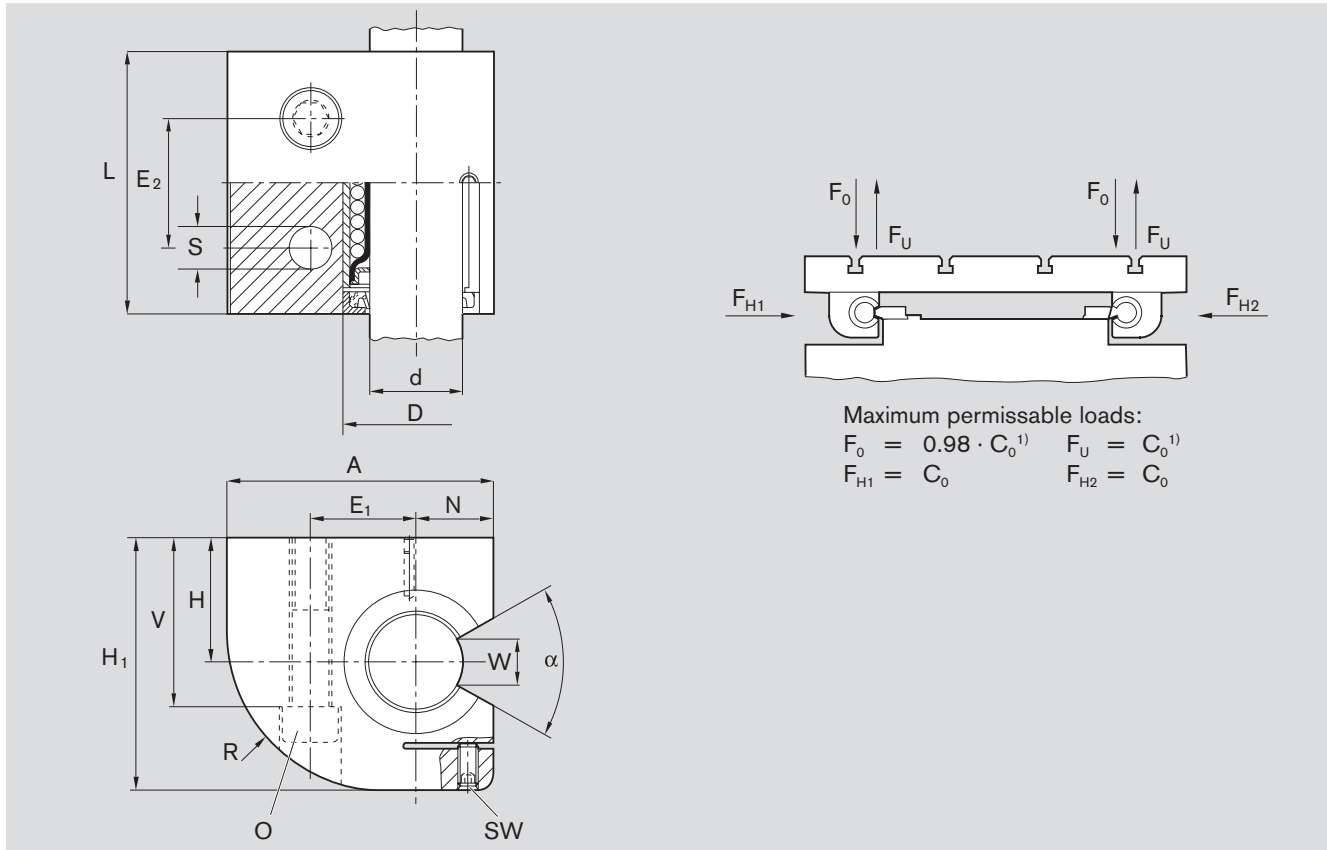

Dimensions [mm]														Angle [°]	Radial clearance ⁶⁾ [μm]		Tolerance [μm] for dimension H ⁷⁾	Load capacities ⁸⁾ [N]		
Ø d	H	H ₁ ³⁾	L ³⁾	A ³⁾	E ₁	E ₂	N	D	V	SSW	O ⁴⁾	W ⁵⁾	R ³⁾		α	R1073 with Shaft h6 h7		R1074	dyn. C	stat. C ₀
20 ²⁾	30	60	60	60	22±0.25	30±0.25	17	32	42	9	2.5	M8x60	10	37	60	+36 +4	+42 +6	+5 -19	1280	970
25 ²⁾	35	72	73	75	28±0.25	36±0.25	21	40	50	11	3	M10x70	12.5	45	60	+38 +4	+44 +6	+5 -19	2270	1750
	30	40	82	85	34±0.50	42±0.50	25	47	55	13.5	3	M12x80	12.5	51	50	+38 +4	+44 +6	+5 -19	2890	2390
	40	45	100	97	43±0.50	48±0.50	32	62	67	15.5	4	M14x90	16.8	66	50	+45 +5	+52 +7	+4 -21	5280	4000
	50	50	115	125	127	50±0.50	62±0.50	38	75	17.5	5	M16x110	21	77	50	+45 +5	+52 +7	+8 -25	8470	6900

¹⁾ Sizes 20 and 25: $F_0 = 0.85 \cdot C_0$; $F_U = 1.27 \cdot C_0$.

²⁾ Contrary to the illustration, the locating screw is on the adjusting side in these sizes.

³⁾ Tolerance DIN 1685-GTB 16.

⁴⁾ Cylinder screws ISO 4762-8.8.

⁵⁾ Minimum dimension based on shaft diameter d.

⁶⁾ When screwed down, relative to shaft.

⁷⁾ When screwed down, relative to shaft nominal dimension d.

⁸⁾ The load capacities apply when the load is acting along the line $\varrho = 0^\circ$ in direction F_{H1} or F_{H2} .

The figures for dynamic load-carrying capacity have been calculated assuming a nominal travel of 100,000 m. For a nominal travel of 50,000 m, the "C" figures in the table must be multiplied by a factor of 1.26.

Linear Sets with Standard Linear Bushings

Linear Sets, R1081
Flanged

Structural design

- Flanged Housing (lamellar graphite cast iron)
- Two retaining rings, plus two spacer rings (steel) for sizes 12 to 40
- Standard Linear Bushing with seals
- The radial clearance is not adjustable

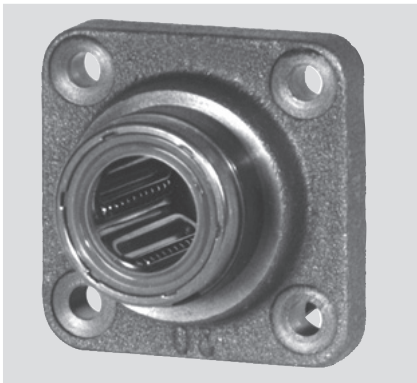

Shaft Ø d [mm]	Part numbers with two seals	Mass [kg]
12	R1081 212 00	0.11
16	R1081 216 00	0.18
20	R1081 220 00	0.33
25	R1081 225 00	0.63
30	R1081 230 00	1.00
40	R1081 240 00	1.90
50	R1081 250 00	4.00
60	R1081 260 00	7.40
80	R1081 280 00	14.70

Dimensions

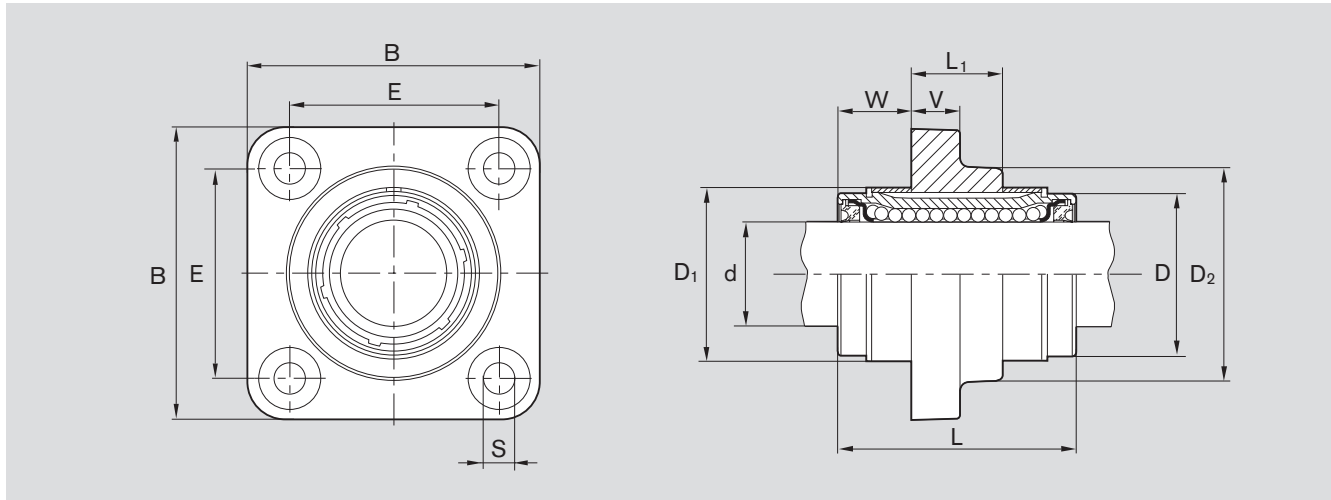

Ø d	B ¹⁾	L	L ₁	Dimensions [mm]			E	S	V ¹⁾	W	Radial clearance ²⁾ [µm] Shaft		Load capacities ³⁾ [N]	
				D	D ₁ +0.8	D ₂ ¹⁾					h6	h7	dyn. C	stat. C ₀
12	42	32	12	22	24	28	30±0.12	5.5	6	10	+20 +5	+26 +6	420	280
16	50	36	15	26	28.5	34	35±0.12	5.5	8	10.5	+22 +5	+28 +6	580	440
20	60	45	18	32	35	42	42±0.15	6.6	10	13.5	+23 +6	+31 +6	1170	860
25	74	58	23	40	43	54	54±0.15	6.6	12	17.5	+25 +6	+32 +7	2080	1560
30	84	68	26	47	49.5	62	60±0.25	9.0	14	21	+25 +6	+32 +7	2820	2230
40	108	80	36	62	66.5	80	78±0.25	11	16	22	+30 +7	+38 +8	5170	3810
50	130	100	72	75	81	98	98±0.25	11	18	14	+30 +7	+38 +8	8260	6470
60	160	125	95	90	96	115	120±0.50	14	22	15	+33 +7	+43 +8	11500	9160
80	200	165	125	120	129	150	155±0.50	14	26	20	+37 +8	+47 +9	21000	16300

¹⁾ Dimensional tolerance DIN 1686-GTB 15.

²⁾ Statistically determined from the working bore diameter and shaft tolerances. Taking the Linear Bushing outer diameter and the housing bore into consideration, the radial clearance values for shaft h7 are similar to those given for the Standard Linear Bushing R0610 in the h7/H7 column under the heading "Adjustable radial clearance".

³⁾ The load capacities stated are minimal values as the position and direction of load cannot always be precisely defined.

The figures for dynamic load-carrying capacity have been calculated assuming a nominal travel of 100,000 m. For a nominal travel of 50,000 m, the "C" figures in the table must be multiplied by a factor of 1.26.



Segmental Linear Bushings

The Advantages

- The Segmental Linear Bushing with plastic reinforced housing is the most economical Linear Set used for general applications
- Shortest Linear Bushing capable of the longest stroke with predetermined shaft length
- Also available in corrosion-resistant for the medical, chemical and food industries
- With separate seals or without seals

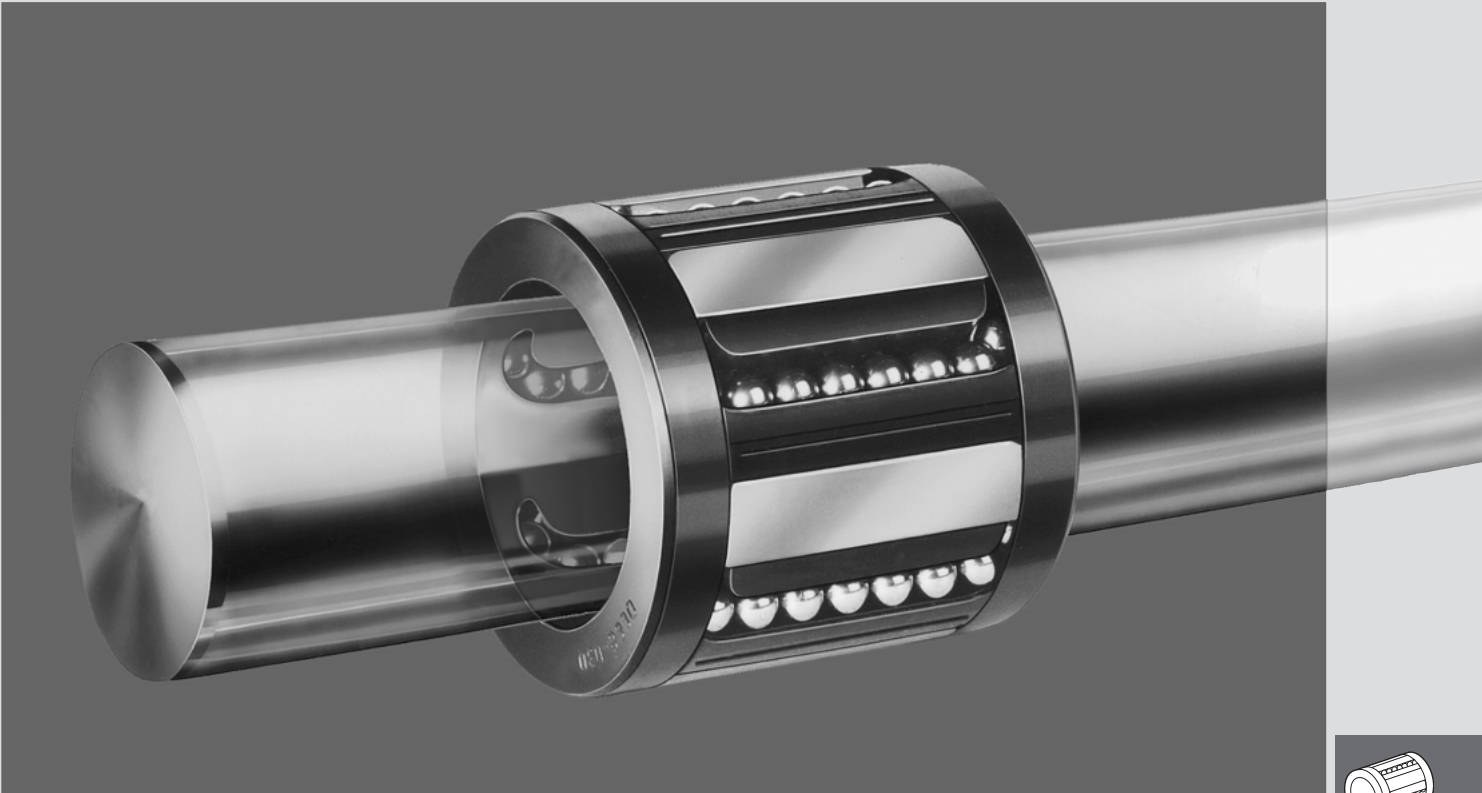

Segmental Linear Bushings

Technical Data

Please observe the general technical principles and mounting instructions at the beginning of this catalog as well as the additional technical data given below.

Friction

The friction μ of unsealed Segmental Linear Bushings using oil as a lubricant lies between 0.001 and 0.004.

The friction is lowest under high load. It may, however, be greater than the stated value when only a slight load is applied. The frictional drag (see table) in the linear bushings sealed at both ends and not subject to radial loading depends on the speed and the type of lubrication.

Shaft \varnothing d [mm]	Breakaway force [N] Approx.	Frictional drag [N] Approx.
12	3	1.5
16	4.5	2
20	5	2.5
25	7	3
30	9	4
40	12	5

Velocity

$$v_{\max} = 3 \text{ m/s}$$

Acceleration

$$a_{\max} = 150 \text{ m/s}^2$$

Operating Temperature

$$-20 \text{ }^{\circ}\text{C to } 100 \text{ }^{\circ}\text{C}$$

Direction of load and its influence on the load capacity

The stated load capacities are valid for installation in "min" position and should be taken as the basis for calculation.

In applications where the direction of load is exactly known and where the Segmental Linear Bushings can be mounted in the "max" position, the load capacity rating must be multiplied by the factors f_{\max} (dynamic load capacity C) or $f_{0\max}$ (static load capacity C_0).

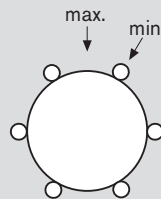

Mounting, Retention

Reduced load capacity in short-stroke applications

In short-stroke applications, the service life of the shafts is shorter than that of the segmental Linear Bushings.

For this reason, the load capacities C listed in the tables must be multiplied by the factor f_w .

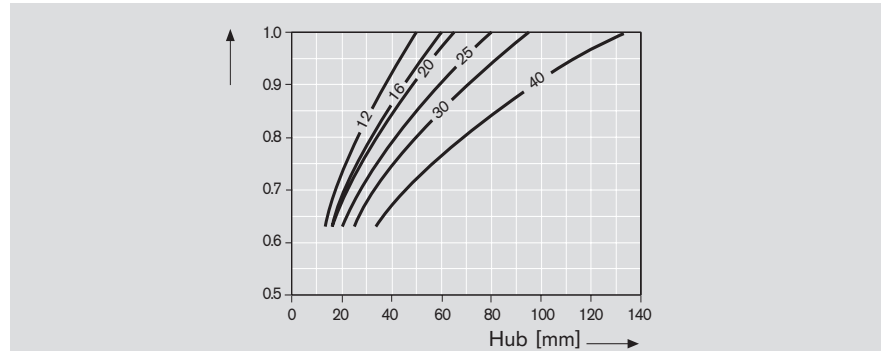

Operation under difficult conditions

In permanently humid or wet environments due for instance to water-based coolants/lubricants, we recommend the use of the corrosion-resistant type to DIN 17230/EN 10088.

Notes for Mounting

Use of an arbor is recommended for installation of Segmental Linear Bushings into the housing bore (see "Mounting Instructions" in the General Technical Data at the beginning of this catalog).

When Segmental Linear Bushings are mounted in an adjustable housing we recommend installing the linear bushing with one of its load bearing plates covering the slot in the housing; this will prevent dirt from entering the linear bushing.

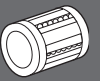

Retention

Retention by means of a seal with a metal case

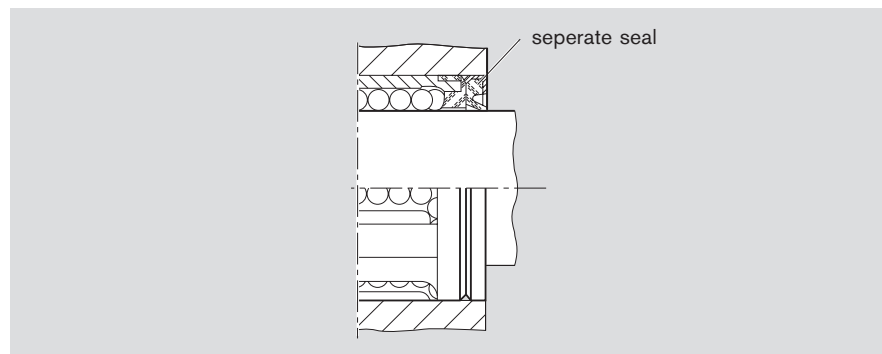

Retention by means of a metal case

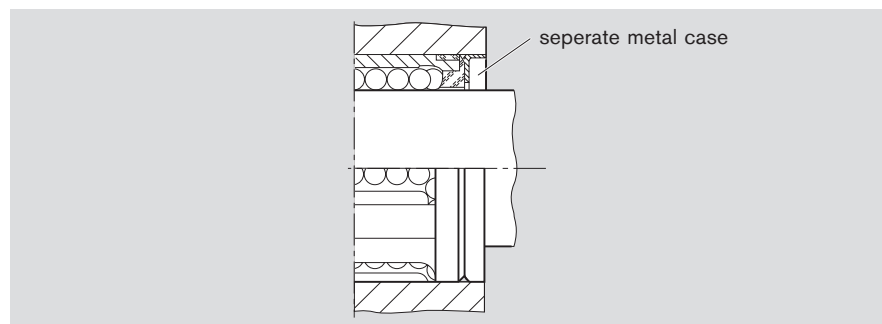

Segmental Linear Bushings

Segmental Linear Bushings, R0668
normal

Structural Design

- Balls made of anti-friction bearing steel
- Hardened steel segmental load bearing plates
- Ball retainer made of polyamide



corrosion-resistant type

Structural Design

- Balls made of anti-friction corrosion-resistant bearing (to ISO 683-17 / EN 10088)
- Corrosion-resistant segmental load bearing plates
- Ball retainer made of polyamide 11

Shaft Ø d [mm]	Part numbers		Mass [kg]
	normal	corrosion-resistant	
12	R0668 012 00	R0668 012 30	0.013
16	R0668 016 00	R0668 016 30	0.020
20	R0668 020 00	R0668 020 30	0.031
25	R0668 025 00	R0668 025 30	0.057
30	R0668 030 00	R0668 030 30	0.096
40	R0668 040 00	R0668 040 30	0.170

Seperate seals



Shaft Ø d [mm]	Part numbers	
	Seal normal ¹⁾	Seal corrosion-resistant ¹⁾
12	R1331 512 00	R1331 512 30
16	R1331 516 00	R1331 516 30
20	R1331 520 00	R1331 520 30
25	R1331 525 00	R1331 525 30
30	R1331 530 00	R1331 530 30
40	R1331 540 00	R1331 540 30

Metal case



Shaft Ø d [mm]	Part numbers	
	Metal case normal ¹⁾	Metal case corrosion-resistant ¹⁾
12	R0901 043 00	R0901 043 30
16	R0901 044 00	R0901 044 30
20	R0901 045 00	R0901 045 30
25	R0901 046 00	R0901 046 30
30	R0901 047 00	R0901 047 30
40	R0901 048 00	R0901 048 30

¹⁾ For axial retention

Dimensions

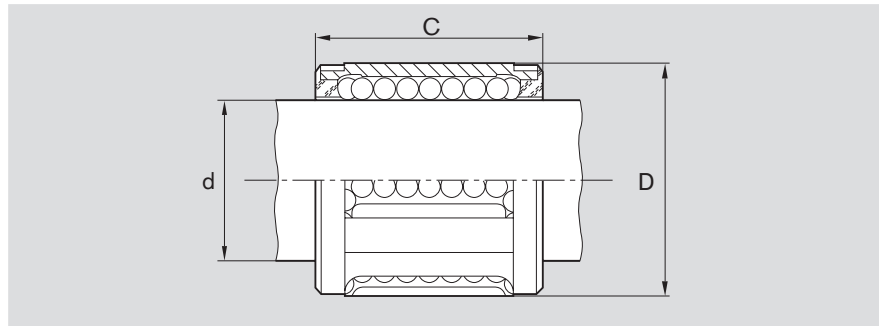

Dimensions [mm]			No. of ball circuits	Radial clearance [μm] shaft/bore			Load capacities [N]									
$\varnothing d$	D	C js14		normal		corrosion-resistant		dyn. C		stat. C_0		dyn. C		stat. C_0		
				h7/H7	h7/JS7	h6/JS6	min	max	min	max	min	max	min	max	min	max
12	20	24	5	+37 +2	+26 -8	+19 -8	480	570	420	620	240	290	330	490		
16	25	28	5	+37 +2	+26 -8	+19 -8	720	860	620	910	360	430	490	730		
20	30	30	6	+38 +2	+28 -9	+20 -9	1020	1080	870	1120	510	540	690	890		
25	37	37	6	+42 +2	+29 -10	+21 -10	1630	1730	1360	1750	820	870	1090	1400		
30	44	44	6	+42 +2	+29 -10	+21 -10	2390	2530	1960	2510	1200	1270	1570	2000		
40	56	56	6	+48 +2	+33 -13	+23 -12	3870	4100	3270	4180	1940	2050	2610	3340		

The figures for dynamic load-carrying capacity have been calculated assuming a nominal travel of 100,000 m. For a nominal travel of 50,000 m, the "C" figures in the table must be multiplied by a factor of 1.26.

Seal

Structural design

- Metal case
- Elastomer seal

Metal case

Material:

- Steel, normal or corrosion-resistant

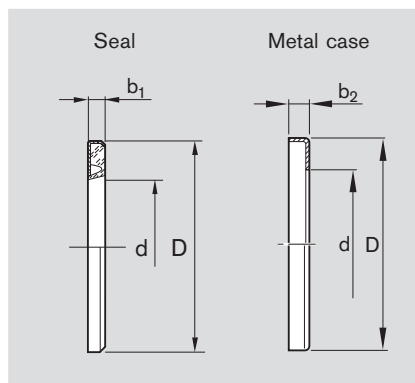

$\varnothing d$	D ¹⁾	Dimensions [mm]	
		b_1 +0.3	b_2 +0.5
12	20	3	3
16	25	3	3
20	30	4	4
25	37	4	4
30	44	5	5
40	56	5	5

¹⁾ Outer diameter D is about 0.1 mm oversized. No special retention elements are necessary.

Linear Sets with Segmental Linear Bushings

Linear Sets, R1060

adjustable

normal or corrosion-resistant

Structural Design

- Pillow Block housing (reinforced polyamide)
- Segmental Linear Bushing
- Two seals with snap covers
- Bolt, washer, nut
- Adjustable radial clearance



Shaft Ø d [mm]	Part numbers		Mass [kg]
	normal	corrosion-resistant ¹⁾	
12	R1060 212 00	R1060 212 20	0.041
16	R1060 216 00	R1060 216 20	0.063
20	R1060 220 00	R1060 220 20	0.077
25	R1060 225 00	R1060 225 20	0.158
30	R1060 230 00	R1060 230 20	0.277
40	R1060 240 00	R1060 240 20	0.470

¹⁾Linear Bushing, corrosion-resistant type (anti-friction bearing steel to DIN 17230 / EN 10088.)

Dimensions

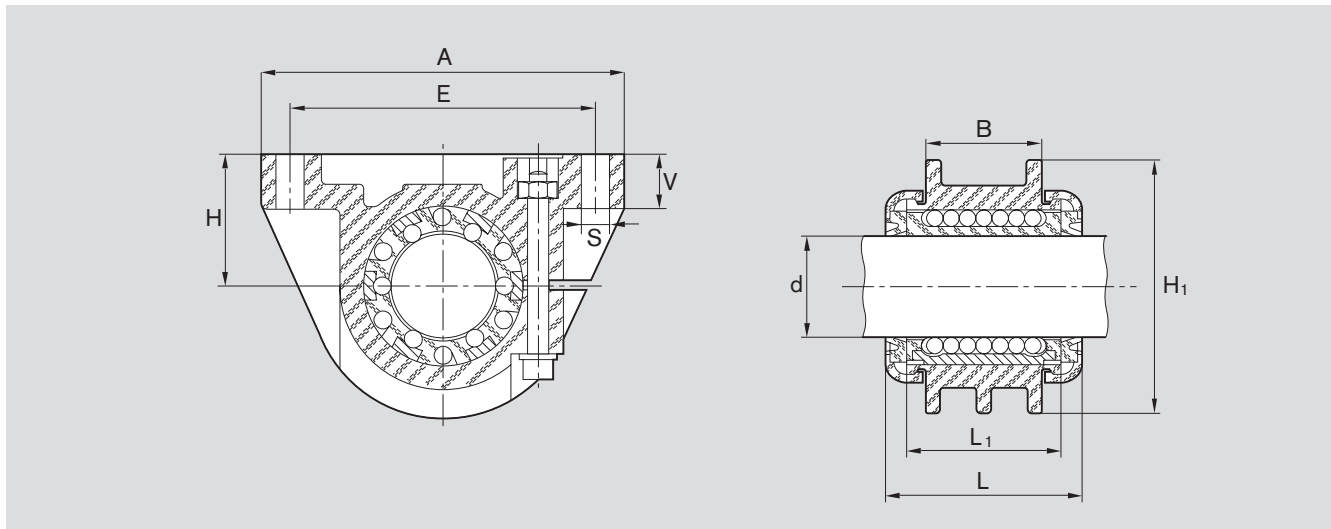

Ø d	H ¹⁾ ±0.05	Dimensions [mm]								Radial clearance [µm]	Load capacities ²⁾ [N]			
		H ₁	L	L ₁	A	B	E	S	V		normal dyn. C	normal stat. C ₀	corrosion-resistant dyn. C	corrosion-resistant stat. C ₀
12	18	35	31	24	55	20	43±0.1	4.4	8	adjusted to zero- clearance on h5 shaft (lower limit) prior to delivery	480	420	240	330
16	22	42	35	28	66	22	53±0.15	5.5	9.5		720	620	360	490
20	25	50	38	30	69	23	58±0.15	5.5	10.5		1020	870	510	690
25	30	60	46	37	87	30	72±0.2	6.6	11.5		1630	1360	820	1090
30	35	70	55	44	97	36	80±0.2	6.6	13		2390	1960	1200	1570
40	45	90	67	56	124	48	103±0.2	8.6	17		3870	3270	1940	2610

¹⁾ Minimum dimension based on shaft diameter d.

²⁾ The load capacities stated are minimal values as the position and direction of load cannot always be precisely defined.

The figures for dynamic load-carrying capacity have been calculated assuming a nominal travel of 100,000 m. For a nominal travel of 50,000 m, the "C" figures in the table must be multiplied by a factor of 1.26.

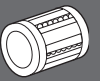

Super Linear Bushings **SH** and **SH**

The Advantages

- Highly precise Linear Bushings for heavy dynamic load-carrying capacity
- Steel insert with ground groove tracks and ground spine for highest precision
- Super **SH** with more tracks than Super **A** and **B** for high capacity
- Super **SH** with even more tracks for highest capacity and stiffness
- High running speed (up to 5 m/s)
- Self-aligning with compensation for shaft deflection
- With or without integrated seals
- Optional longitudinal seal for open Linear Bushings
- Linear sets with aluminum housing

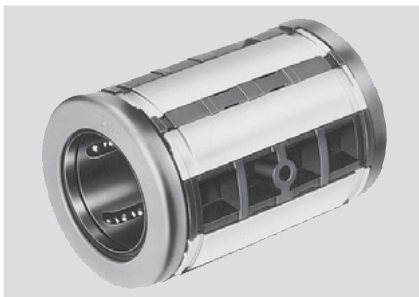

Closed (Super **SH**)



Closed (Super **SH**)

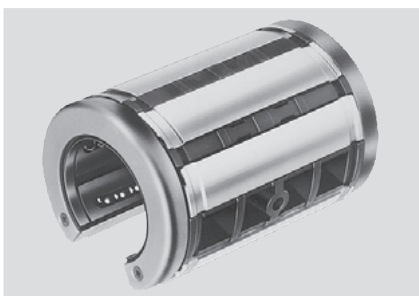



Open (Super **SH**)

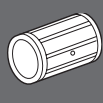
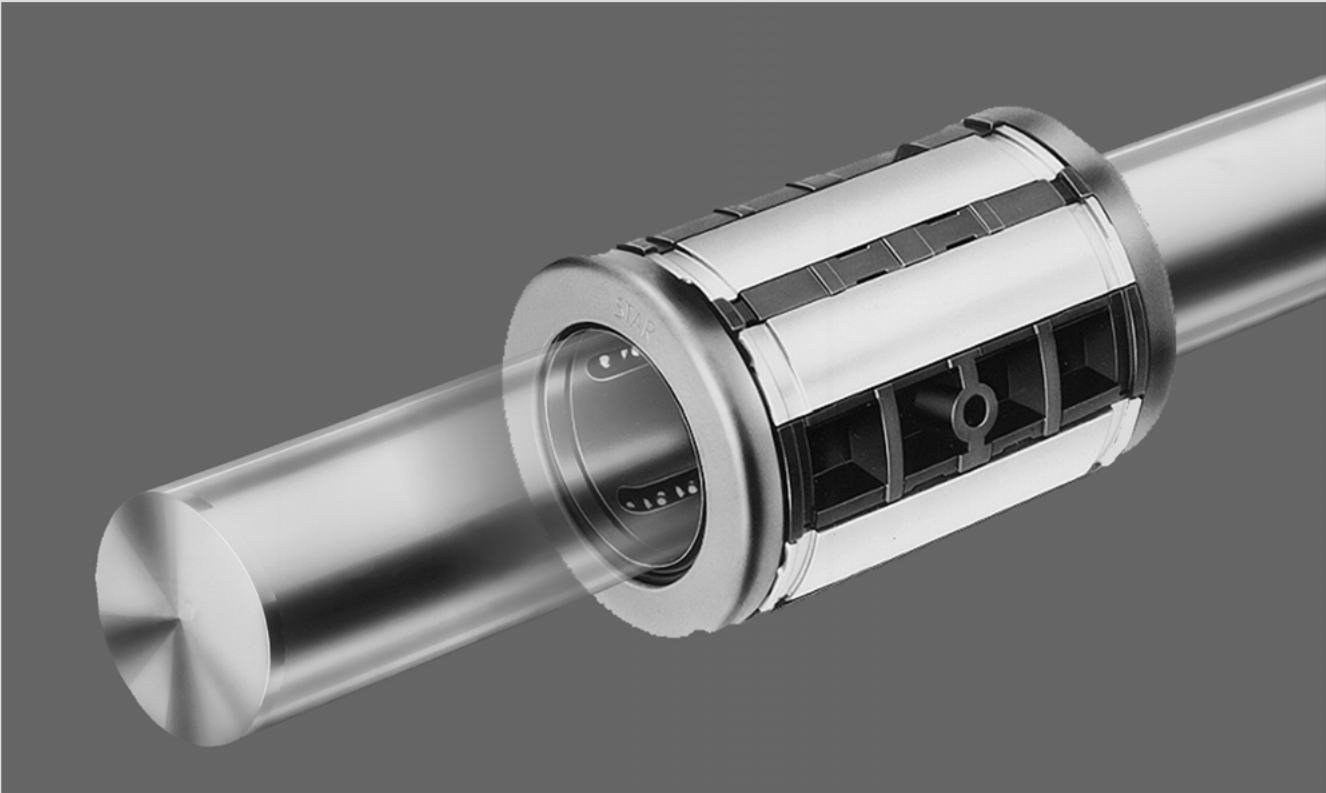

Open (Super **SH**)







Super Linear Bushings  and 

Technical Data

Please observe the general technical principles and mounting instructions at the beginning of this catalog as well as the additional technical data given below.

Dimensions/Interchangeability

Super Linear Bushings  and  have the same outside dimensions as Super Linear Bushings  and  as well as Standard Linear Bushings (caution: different retention, radial clearance, load capacity and lubrication). For this reason, all the versions are interchangeable.

Abdichtung

Two-fold protection through dual-action seals:

- the outer lip prevents the penetration of dirt and foreign bodies
- the inner lip prevents excessive loss of lubricant

In closed types, the seals are flexibly mounted, floating into good contact under all service conditions. The open types also have a seal strip to fully seal the gap between the ball retainer and the shaft. All seals can be replaced if necessary.

Friction

Very low friction due to the rolling friction principle. Extremely low breakaway forces. The friction μ of unsealed Super Linear Bushings using oil as a lubricant lies between 0.001 and 0.004.

The friction is lowest under high load. It may, however, be greater than the stated value when only a slight load is applied.

For Super Linear Bushings fitted at both ends with internal wiper seals and not subject to radial loading, the frictional drag (see table below) depends on the speed and the type of lubrication.

Shaft Ø d mm	closed and open with internal wiper seals		open fully sealed	
	Breakaway force [N] approx.	Frictional drag [N] approx.	Breakaway force [N] approx.	Frictional drag [N] approx.
20	5	2.5	7.5	4
25	7	3	10.5	4.5
30	9	4	13.5	6
40	12	5	18	7.5
50	15	6	22.5	9
60	18	7	27	10.5

Velocity

$$v_{\max} = 5 \text{ m/s}$$

Acceleration

$$a_{\max} = 150 \text{ m/s}^2$$

Operating temperature

$$-20 \text{ }^{\circ}\text{C to } 100 \text{ }^{\circ}\text{C}$$

Direction of load and its influence on the load-carrying capacity

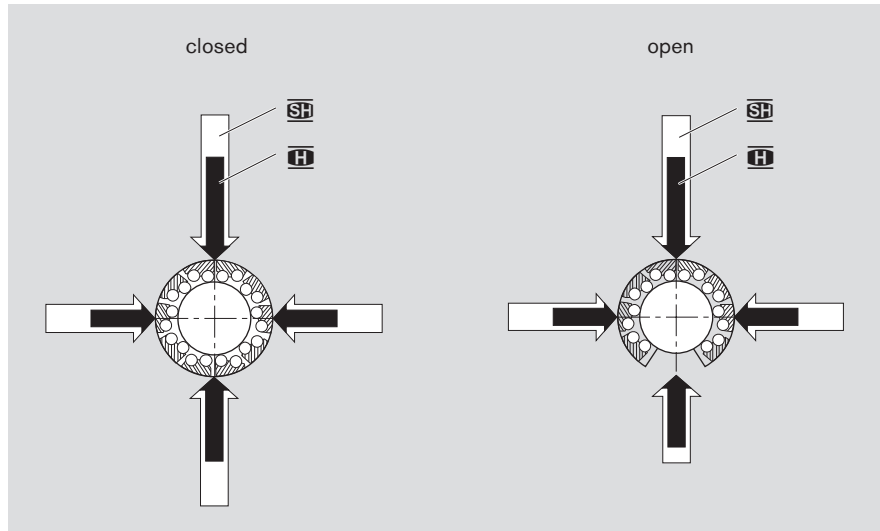

Main load direction

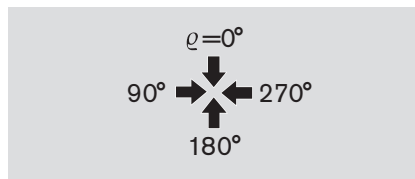



Load direction factors

The load capacities C and C_0 apply when the load is acting along the line $\varrho = 0^\circ$.

If the load is acting in any other direction, these load capacities must be multiplied by the factors f_ϱ (dynamic load capacity C) or f_{ϱ_0} (static load capacity C_0).

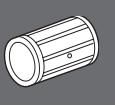
Shaft $\varnothing d$ [mm]	Load capacity factor f_ϱ											
	Super Linear Bushing SH						Super Linear Bushing SH					
	↓	→	←	↑	↓	→	←	↑	↓	→	←	↑
20-25	1	0.80	0.98	1	0.80	0.67	1	0.79	1	1	0.79	0.52
30-60	1	0.70	0.91	1	0.70	0.62	1	0.86	1	1	0.86	0.59
	Load capacity factor f_{ϱ_0}											
20-25	1	0.70	0.87	1	0.70	0.67	1	0.68	1	1	0.68	0.50
30-60	1	0.62	0.80	1	0.62	0.61	1	0.83	1	1	0.83	0.55



Super Linear Bushings  and 

Technical Data

Load direction factors

Super Linear Bushing 
Shafts \varnothing d 20-25

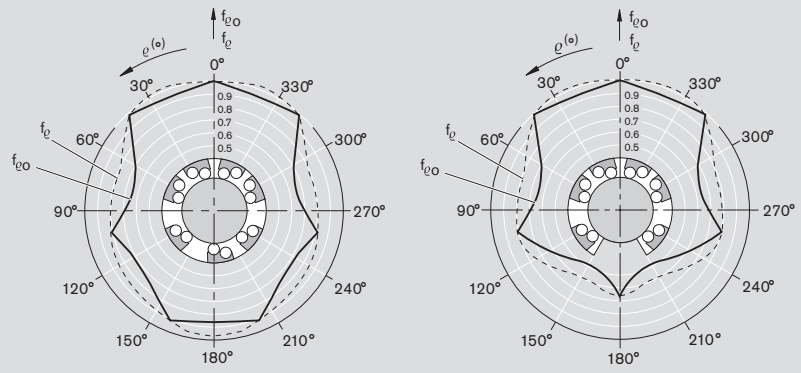

closed type

open type

Shafts \varnothing d 30-60

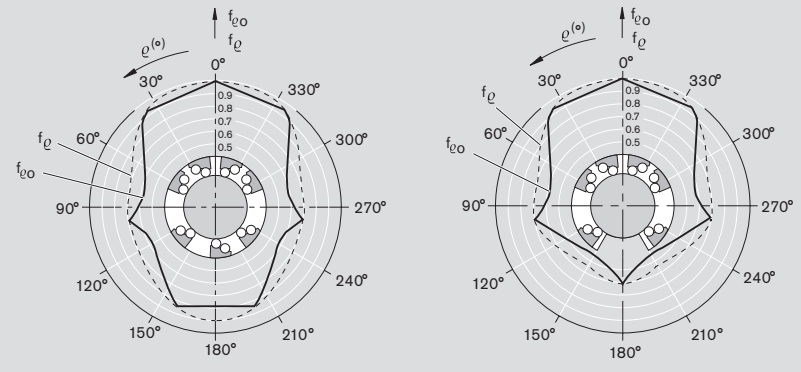

closed type

open type

Super Linear Bushings can be installed in any mounting position. The mounting position should be chosen so that the load acts mainly along the line $\rho = 0^\circ$.

Super Linear Bushing 
Shafts $\varnothing d$ 20-25

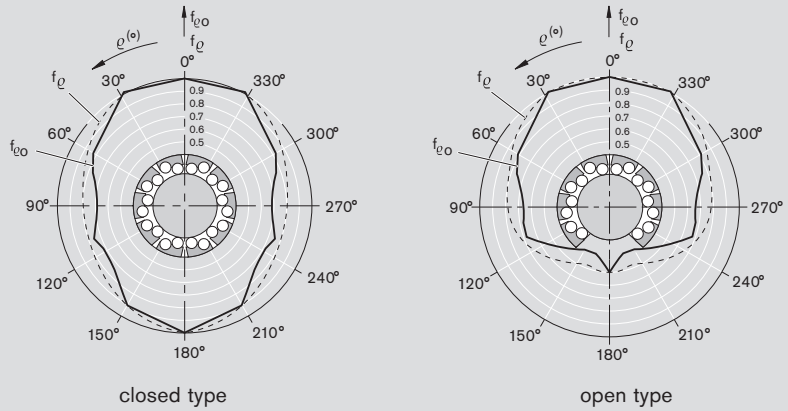

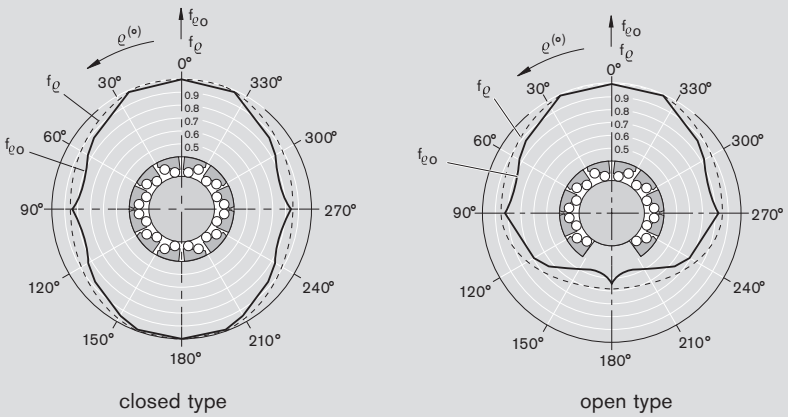

Shafts $\varnothing d$ 30-50

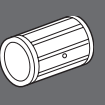
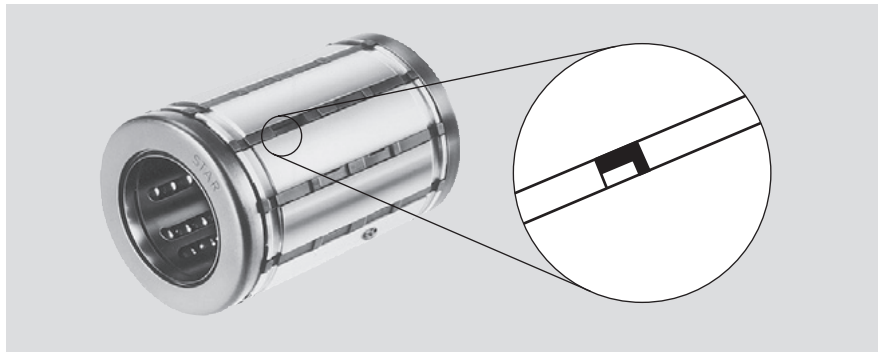

Super Linear Bushings can be installed in any mounting position. The mounting position should be chosen so that the load acts mainly along the line $\varrho = 0^\circ$.

An indentation in the plastic ball retainer of closed Super Linear Bushing  (see magnification) indicates the main direction of load $\varrho = 0^\circ$ (maximum load capacity).



Super Linear Bushings  and 

Technical Data

Reduced load capacity in short-stroke applications



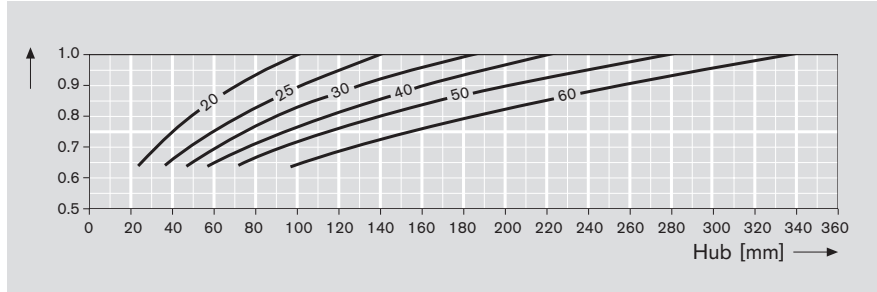

In short-stroke applications, the service life of the shafts is shorter than that of the Super Linear Bushings. For this reason, the load capacities C given in the tables must be multiplied by the factor f_w .



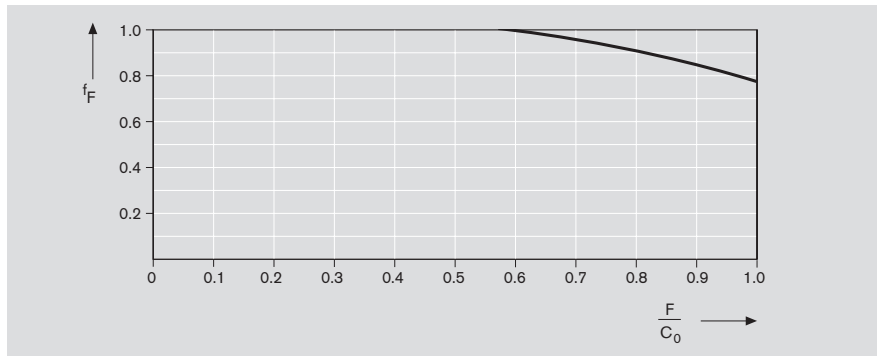

Reduced load capacity at high loads

Reduced load capacity at high loads F . The dynamic load capacity must be multiplied by the load factor f_F .

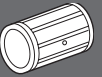

Self-alignment	Super Linear Bushings automatically compensate for alignment errors of up to 30'. No reduction in load-carrying capacity due to pressure between bushing edge and shaft.
Running speed and characteristics	High acceleration and running speed due to: <ul style="list-style-type: none">• Hard-wearing ball retainer Smooth and stutter-free running of the balls in the ball tracks due to: <ul style="list-style-type: none">• Optimized track geometry at both ends• Ground ball tracks
Ground outer surfaces	The ground outer surface of the load bearing plates produces very good contact between the steel bearing plates and the inner surface of the mounting hole.
Load-carrying capacity and service life	The high number of ball tracks provides a very high load-carrying capacity and service life
Lubrication	In-service lubrication is possible via the lube hole in closed type  or via the grease pockets in the ball retainer in types  and  .
Retention	Super Linear Bushings  and  feature simple and economical radial and axial retention by locating screw.



Super Linear Bushings  and 

Customer-built housing

Retention

Super Linear Bushing 

Retention by means of locating screw inserted through hole S_1 .

Important

Observe position of bearing plates relative to locating screw hole S_1 .

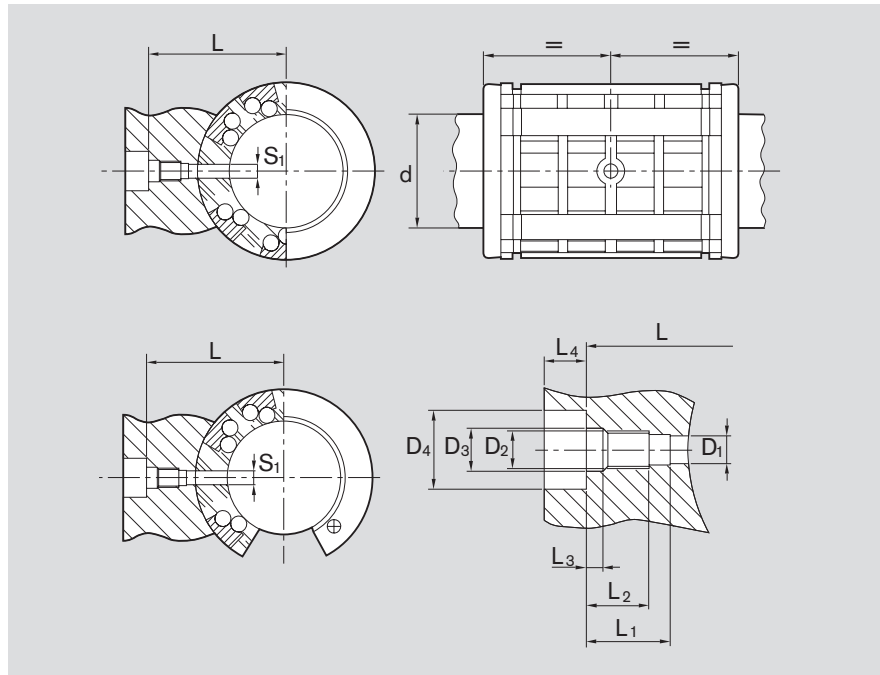

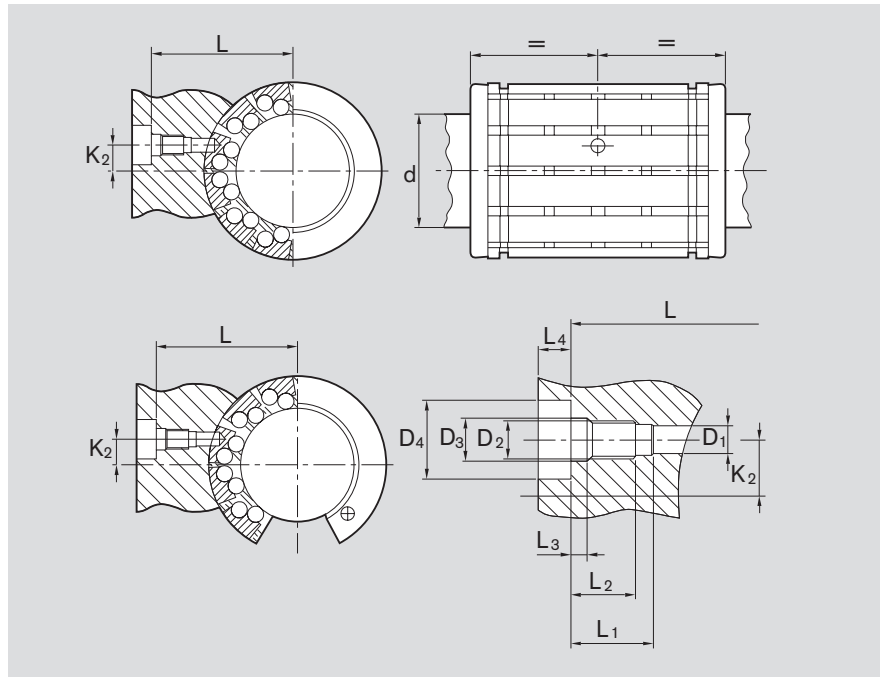

Shaft [mm]	Dimensions [mm]										Locating screw	
	S_1	L	L_1	L_2	L_3	L_4	D_1	D_2	D_3	D_4	Part numbers	Tightening torque [Nm]
20	3	±0.1 27	+0.2 9	+0.2 7	+0.2 2	min 3.2	+0.1 3.1	M4	H13 4.5	H13 8	R3427 008 09	1.9
25	3.5	33.5	11	8,5	2.3	4	3.6	M5	5.5	10	R3427 003 09	3.8
30	3.5	37	11	8,5	2.3	4	3.6	M5	5.5	10	R3427 003 09	3.8
40	3.5	44.5	11	8,5	2.3	4	3.6	M5	5.5	10	R3427 003 09	3.8
50	4.5	59.5	17	14	3	4.7	4.6	M6	6.6	11	R3427 004 09	6.7
60	6	72.5	22	18	4	6	6.2	M8	9	15	R3427 007 09	16

Super Linear Bushing 
Retention by means of locating screw.

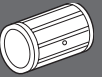

Shaft [mm]	Dimensions [mm]										Locating screw	
	L +0,2	K ₂	L ₁ +0,2	L ₂ min.	L ₃ +0,2	L ₄ min	D ₁ +0,1	D ₂	D ₃ H13	D ₄ H13	Part numbers	Tightening torque [Nm]
20	26.85	1.3	9	7	2	3.2	2.6	M4	4.5	8	R3427 001 09	1.9
25	30.75	2	9	7	2	3.2	2.6	M4	4.5	8	R3427 001 09	1.9
30	38.15	7	11	8.5	2,3	4	3.6	M5	5.5	10	R3427 003 09	3.8
40	44.75	9.5	11	8.5	2,3	4	3.6	M5	5.5	10	R3427 003 09	3.8
50	59.75	10	17	14	3	4.7	4.6	M6	6.6	11	R3427 004 09	6.7



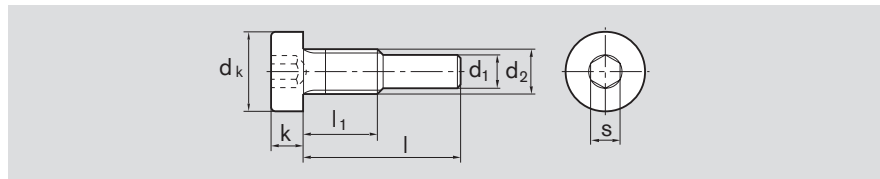

Locating screw
For retention of Super Linear Bushing  and .



Dimensions [mm]							Locating screw	
d ₂	d _k	d ₁	l	l ₁	k	s	Part numbers	Tightening torque [Nm]
M4	7	2.5	12	6.3	2.8	2.5	R3427 001 09	1.9
M4	7	3	14.1	6.5	2.8	2.5	R3427 008 09	1.9
M5	8.5	3.5	17	8	3.5	3	R3427 003 09	3.8
M6	10	4.5	26	13.5	4	4	R3427 004 09	6.7
M8	13	6	33	17	5	5	R3427 007 09	16

All other dimensions to DIN 7984.

Super Linear Bushings  and 

Customer-built housing

Lubrication and retention

Super Linear Bushing 
(closed type)

Lubrication and retention by means of hollow screw inserted through hole S_1 . Dimensions given here are for customer-built housing.

Important:

Observe the position of load bearing plates relative to hole S_1 .

The lubrication channels shown here have been designed for lubrication with grease. If oil is used instead, check whether all anti-friction bearings are being properly lubricated.

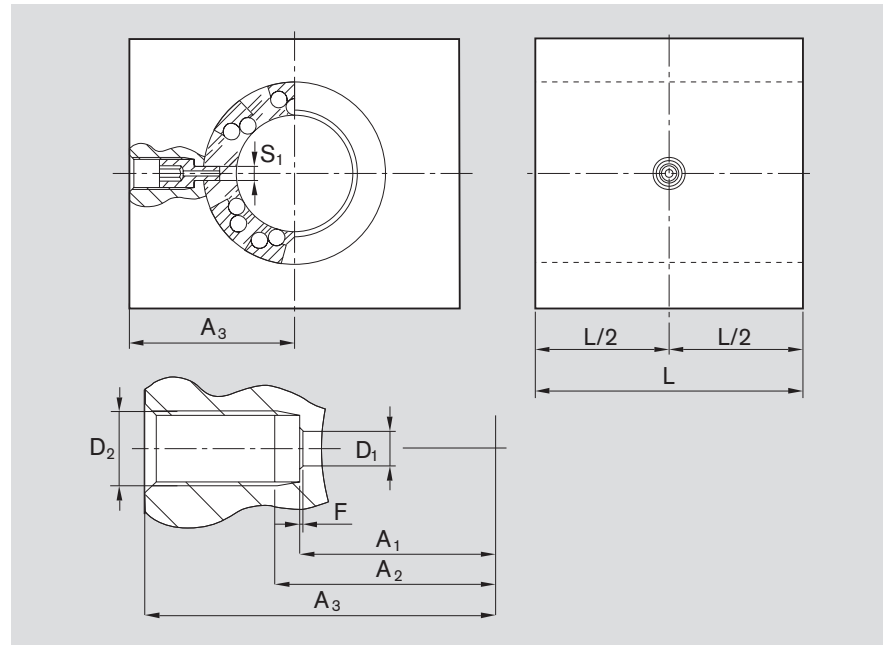

Part numbers Super Linear Bushing 	Dimensions [mm]								Hollow screw	
	S_1	L min.	D_1 +0.1	D_2	A_1 ± 0.1	A_2 max.	A_3 min.	F	Part numbers	Tightening torque [Nm]
R0732 220 40	3	46	3.1	M8x1	18.5	20.5	31	0.3x45°	R3432 010 00	5.5
R0732 225 40	3.5	59	3.6	M8x1	22.5	25	38	0.3x45°	R3432 007 00	5.5
R0732 230 40	3.5	69	3.6	M8x1	26	28.5	41.5	0.3x45°	R3432 007 00	5.5
R0732 240 40	3.5	81	3.6	M8x1	33.5	36	49	0.3x45°	R3432 007 00	5.5
R0732 250 40	4.5	101	4.6	M8x1	42	44.5	59	0.3x45°	R3432 008 00	5.5
R0732 260 40	6	126	6.2	M10x1	51	53.5	71.5	0.3x45°	R3432 009 00	9.5

Hollow screw

For lubrication and retention of Super Linear Bushing  (closed type) through hole S_1 .

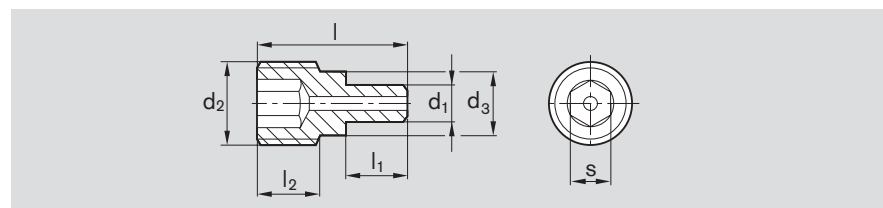

Dimensions [mm]								Hollow screw	
d_2	d_1	d_3	l	l_1	l_2	s	Part numbers	Tightening torque [Nm]	
M8x1	3	6,5	10,5	5	3,5	4	R3432 010 00	5,5	
M8x1	3,5	6,5	14,5	6	5,6	4	R3432 007 00	5,5	
M8x1	4,5	6,5	18	8	7	4	R3432 008 00	5,5	
M10x1	6	8,5	25	11,5	10,2	5	R3432 009 00	9,5	

Lubrication

Super Linear Bushing 

(closed type)

Lubrication channel, ring groove and lube nipple thread are for lubricating with grease. Dimensions given for customer-built housing.

Part numbers Super- Linear Bushing 	Dimensions [mm]				
	D	L min	L ₁ +0.5	H ₁	D ₁ ±0.2
R0730 220 40	32	46	7	16	34
R0730 225 40	40	59	8.5	20	42
R0730 230 40	47	69	8.5	23.5	50
R0730 240 40	62	81	10.5	31	66
R0730 250 40	75	101	11.5	37.5	79

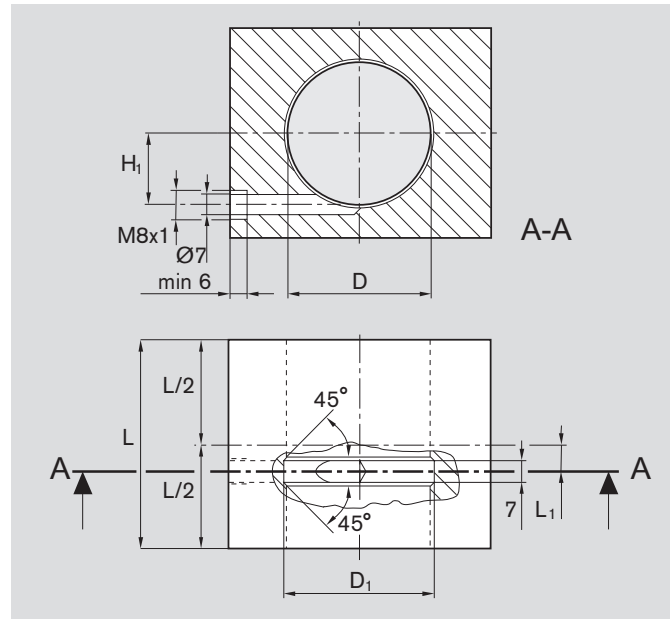



Super Linear Bushing  and 

(open type)

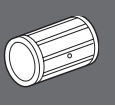
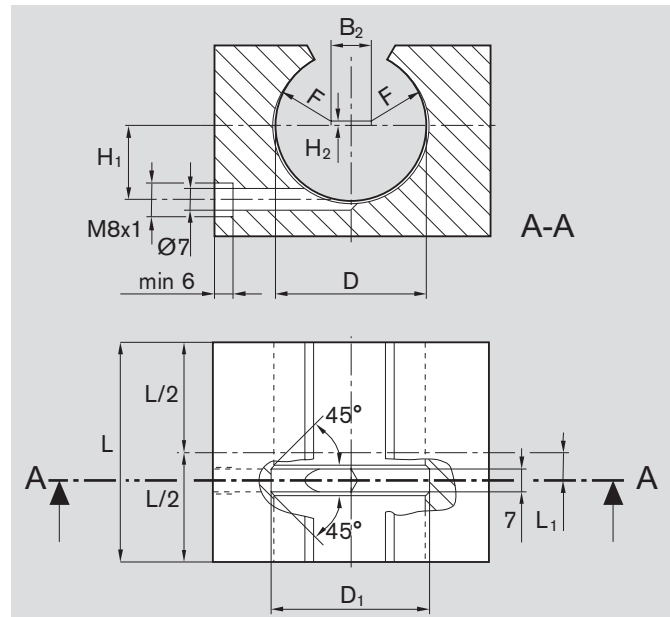
Lubrication channel, ring groove and lube nipple thread are for lubricating with grease. Dimensions given for customer-built housing.



Part numbers Super Linear Bushing		Dimensions [mm]							
		D	L min.	L ₁ +0,5	H ₁	D ₁ ±0,2	B ₂	H ₂	F
R0733 220 45	R0731 220 45	32	46	7	16	34	8	-	R13
R0733 225 45	R0731 225 45	40	59	8.5	20	42	11,9	0,5	R15
R0733 230 45	R0731 230 45	47	69	8.5	23.5	49	12.8	1	R18
R0733 240 45	R0731 240 45	62	81	10.5	31	66	19.9	1,1	R23
R0733 250 45	R0731 250 45	75	101	11.5	37.5	79	22.6	2	R28
R0733 260 45	-	90	126	13	45	94	30.8	3	R31.5

Super Linear Bushing 

Super Linear Bushing, R0732 closed type



Super Linear Bushing, R0733 open type

Structural design

- POM ball retainer
- Hardened steel segmental load bearing plates with ground ball tracks and ground outer surfaces
- Two metal holding rings
- With or without twin-lip seal rings
- With or without axial seal strip.

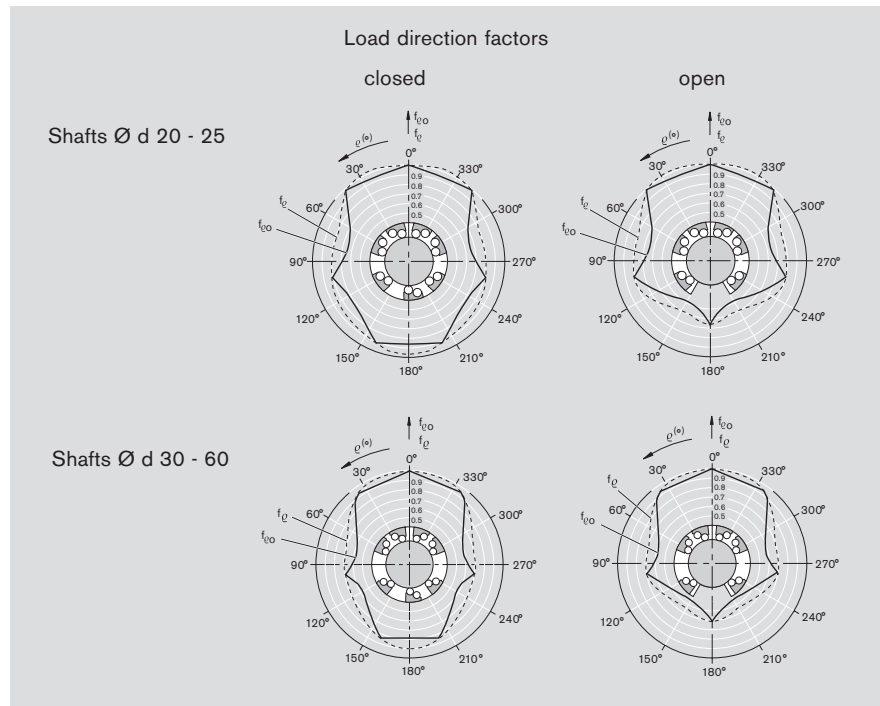

For precise values for the 4 main directions of load see "Technical Data – Load capacity factors".



Shaft $\varnothing d$ [mm]	Part numbers		Mass [kg]
	without seal	with two seals	
20	R0732 020 00	R0732 220 40	0.070
25	R0732 025 00	R0732 225 40	0.150
30	R0732 030 00	R0732 230 40	0.210
40	R0732 040 00	R0732 240 40	0.400
50	R0732 050 00	R0732 250 40	0.700
60	R0732 060 00	R0732 260 40	1.200
			

With one seal ring: R0732 1.. 40 or R0733 1.. 40



Shaft $\varnothing d$ [mm]	Without seal	Part numbers		Mass [kg]
		with two seals	fully sealed	
20	R0733 020 00	R0733 220 40	R0733 220 45	0.060
25	R0733 025 00	R0733 225 40	R0733 225 45	0.130
30	R0733 030 00	R0733 230 40	R0733 230 45	0.180
40	R0733 040 00	R0733 240 40	R0733 240 45	0.350
50	R0733 050 00	R0733 250 40	R0733 250 45	0.600
60	R0733 060 00	R0733 260 40	R0733 260 45	1.000
				

Dimensions

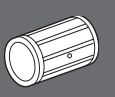
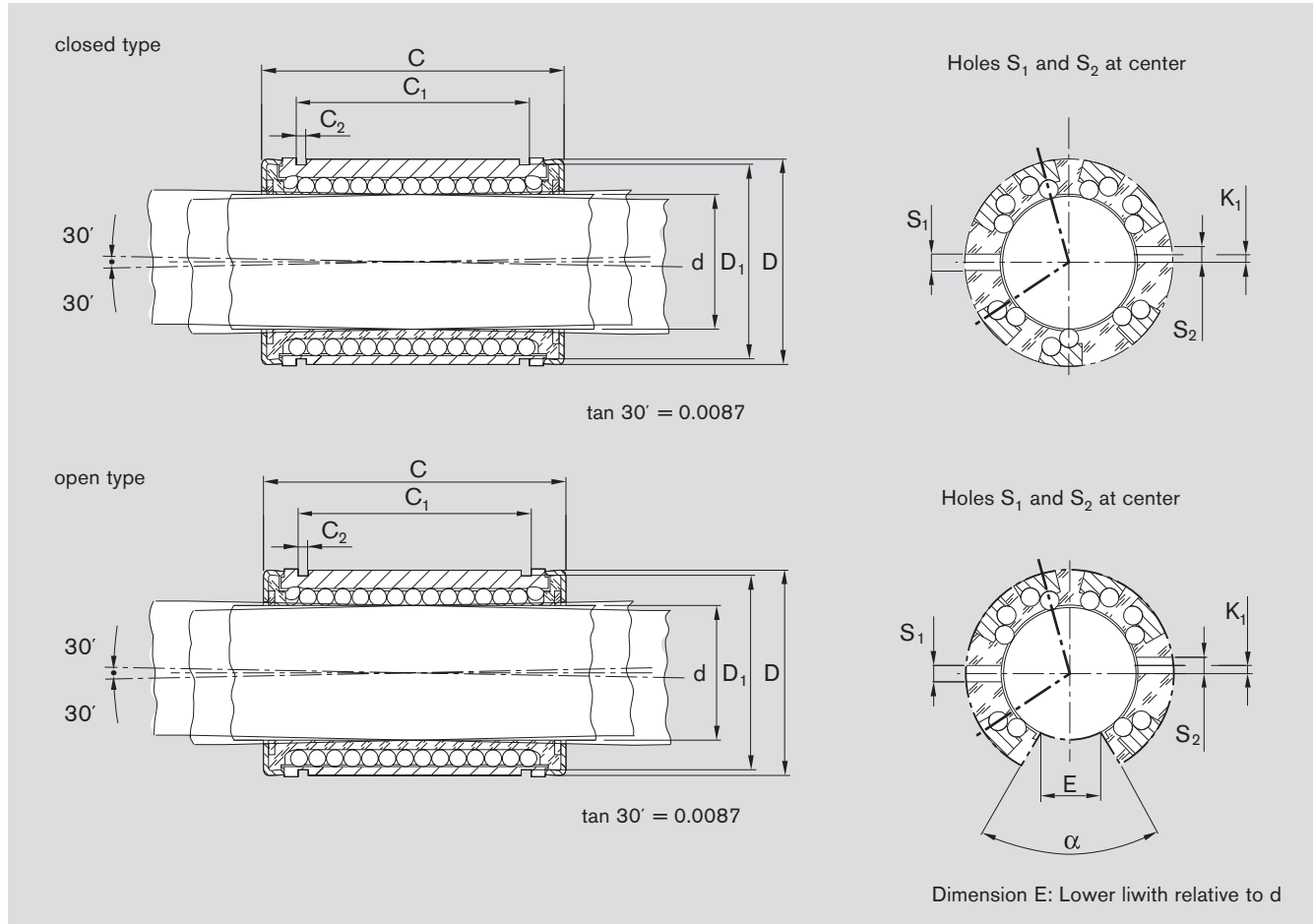

Ø d	D	Dimensions [mm]					No. of ball circuits		Angle α [°]	Radial clearance [µm]				Load capacity ¹⁾ [N]				
		C _{h13}	C _{H13}	C ₂	D ₁	S ₁	S ₂	K ₁		E	Shaft/bore				dyn. C	stat. C ₀		
						+0.1	+0.1			h7/H7	h7/JS7	h6/JS6	h6/K6					
20	32	45	31.2	1.6	30.5	3.0	-	-	9.5	7	6	60	+49 +13	+37 0	+28 +1	+23 -4	2520	1880
25	40	58	43.7	1.85	38.5	3.5	3	-1.5	12	7	6	60	+49 +13	+37 0	+28 +1	+23 -4	4430	3360
30	47	68	51.7	1.85	44.5	3.5	3	2	12.8	7	6	60	+49 +13	+37 0	+28 +1	+23 -4	6300	5230
40	62	80	60.3	2.15	59	3.5	3	1.5	16.8	7	6	60	+57 +14	+42 -1	+31 +1	+25 -4	9680	7600
50	75	100	77.3	2.65	72	4.5	5	2.5	22.1	7	6	60	+57 +14	+42 -1	+31 +1	+25 -4	16000	12200
60	90	125	101.3	3.15	86.5	6.0	-	-	27	7	6	60	+65 +16	+47 -1	+34 +1	+27 -6	23500	18700

¹⁾ The figures given for load capacity are maximum values as the position and load direction can be precisely defined.

The figures for dynamic load-carrying capacity have been calculated assuming a nominal travel of 100,000 m. For a nominal travel of 50,000 m, the 'C' figures in the table must be multiplied by a factor of 1.26.

Super Linear Bushing 

Super Linear Bushing, R0730 closed type

Super Linear Bushing, R0731 open type



Structural design

- Polyacetal ball retainer
- Hardened steel segmental load bearing plates with ground ball tracks and ground outer surfaces
- Two metal holding rings
- With or without twin-lip seal rings
- With or without axial seal strip.

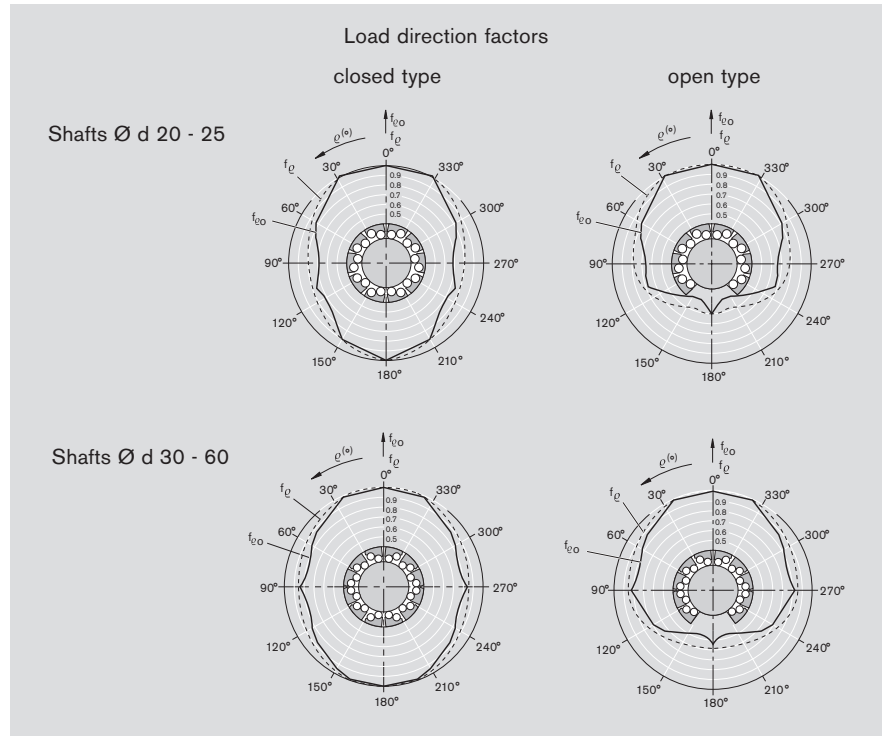
For precise values for the 4 main directions of load see "Technical Data – Load capacity factors".





closed type

Shaft Ø d [mm]	Part numbers		Mass [kg]
	without seal	with two seals	
20	R0730 020 00	R0730 220 40	0.090
25	R0730 025 00	R0730 225 40	0.190
30	R0730 030 00	R0730 230 40	0.300
40	R0730 040 00	R0730 240 40	0.600
50	R0730 050 00	R0730 250 40	1.050
			

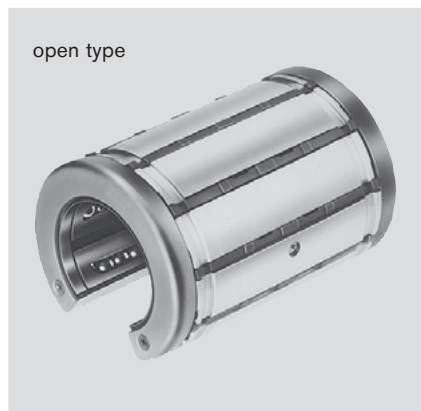
With one seal: R0730 1.. 40 oder R0731 1.. 40.



open type

Shaft Ø d [mm]	Part numbers			Mass [kg]
	without seal	with two seals	fully sealed	
20	R0731 020 00	R0731 220 40	R0731 220 45	0.075
25	R0731 025 00	R0731 225 40	R0731 225 45	0.160
30	R0731 030 00	R0731 230 40	R0731 230 45	0.250
40	R0731 040 00	R0731 240 40	R0731 240 45	0.500
50	R0731 050 00	R0731 250 40	R0731 250 45	0.900
				

Dimensions

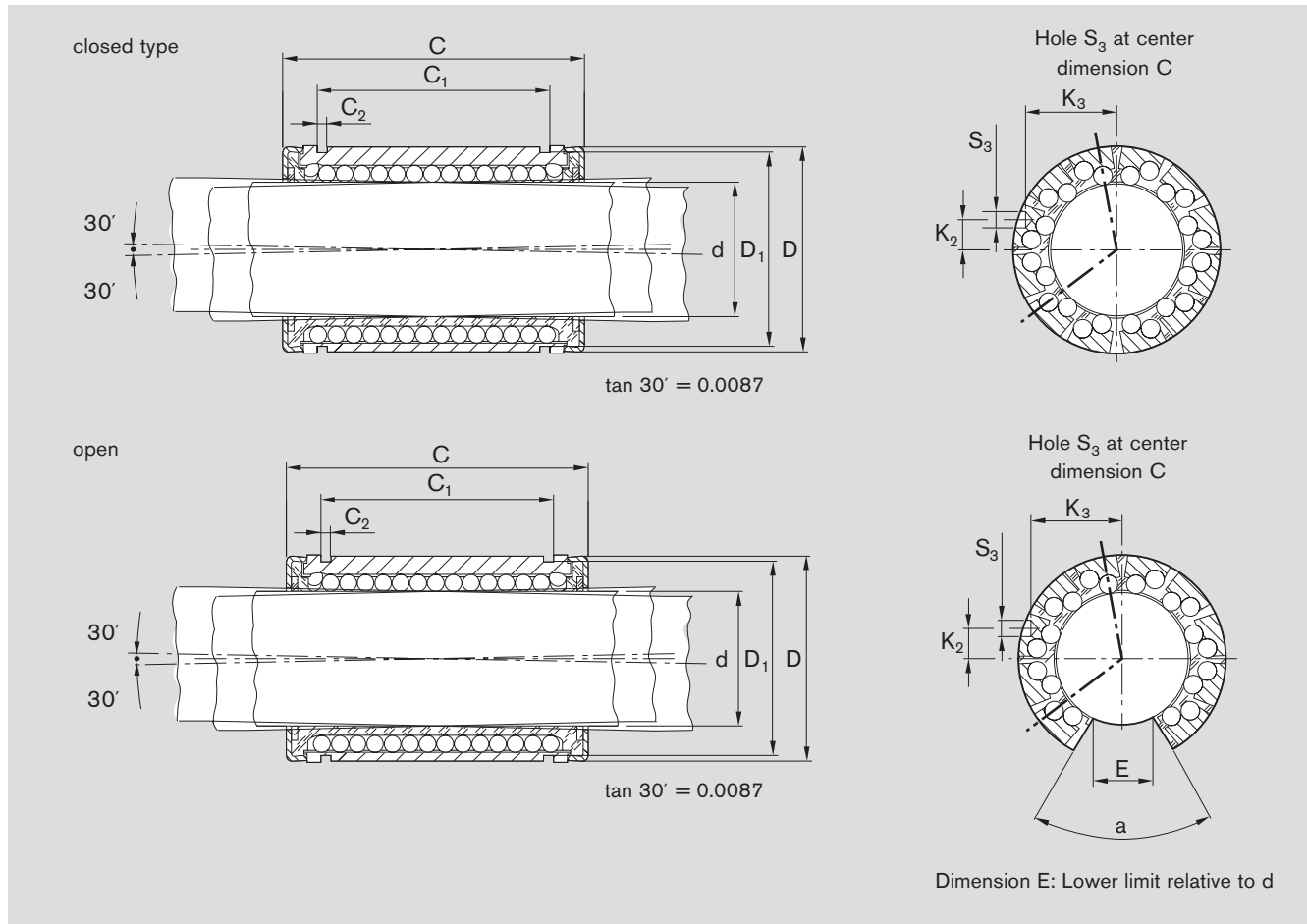

Ø d	D	Dimensions [mm]									No. of ball circuits		Angle α [°]	Radial clearance [μm]				Load capacity ¹⁾ [N]	
		C _{h13}	C _{H13}	C ₂	D ₁	S ₃ +0.1	K ₂	K ₃	E	h7/H7	h7/JS7	h6/JS6		h6/K6	dyn. C	stat. C ₀			
20	32	45	31.2	1.6	30.5	2.6	1.3	14.7	9.5	10	8	60	+49 +13	+37 0	+28 +1	+23 -4	3530	2530	
25	40	58	43.7	1.85	38.5	2.6	2	18.5	12	10	8	60	+49 +13	+37 0	+28 +1	+23 -4	6190	4530	
30	47	68	51.7	1.85	44.5	3.6	7	21	12.8	12	10	60	+49 +13	+37 0	+28 +1	+23 -4	8800	7180	
40	62	80	60.3	2.15	59	3.6	9.5	27.5	16.8	12	10	60	+57 +14	+42 -1	+31 +1	+25 -4	13500	10400	
50	75	100	77.3	2.65	72	4.6	10	33.5	22.1	12	10	60	+57 +14	+42 -1	+31 +1	+25 -4	22300	16800	

¹⁾ The figures given for load capacity are maximum values as the position and load direction can be precisely defined.

The figures for dynamic load-carrying capacity have been calculated assuming a nominal travel of 100,000 m. For a nominal travel of 50,000 m, the 'C' figures in the table must be multiplied by a factor of 1.26.

Linear Sets with Super Linear Bushings  or 

Technical Data

Tolerances, parallelism of guideway in service

Linear sets R1703, R1704 with shaft support rail R1014 and shaft.

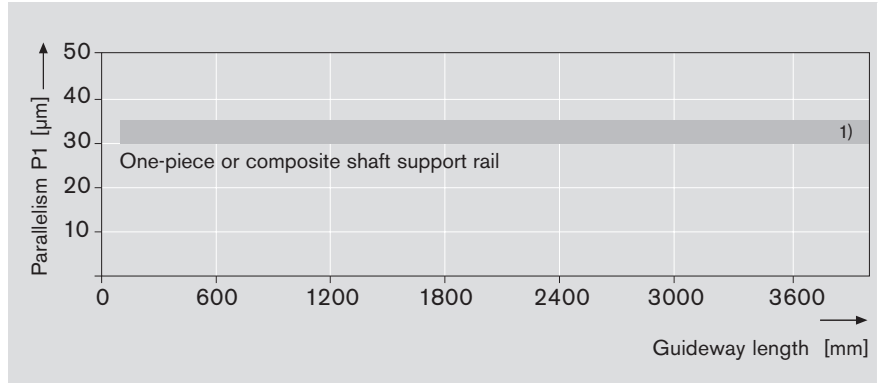

Linear sets R1703, R1704 with shaft support rail R1016 and shaft.

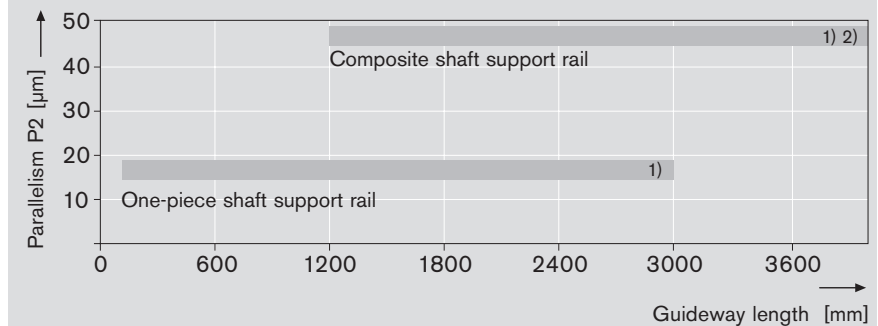
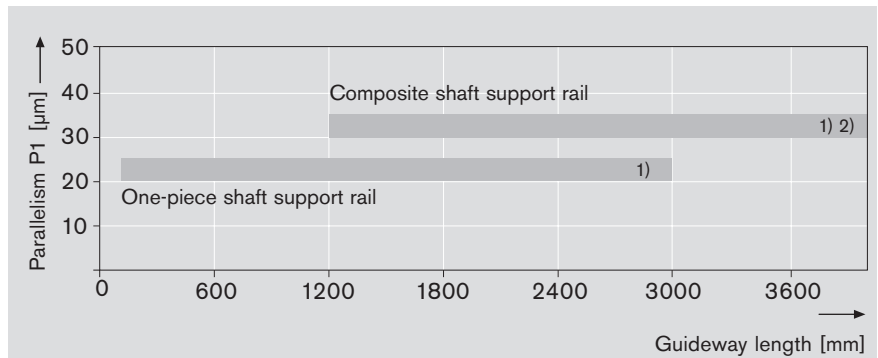

Linear sets R1706 with shaft support rail R1015 and shaft

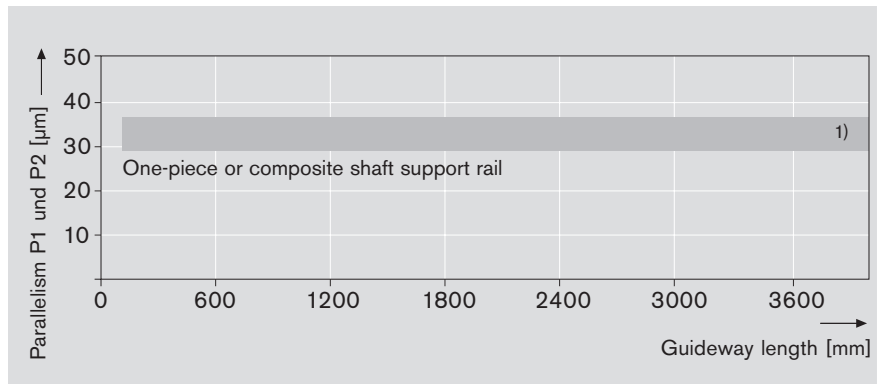

1) For precise values see "Tolerances" table

2) Composite shaft support rail made up of several sections of the same grade

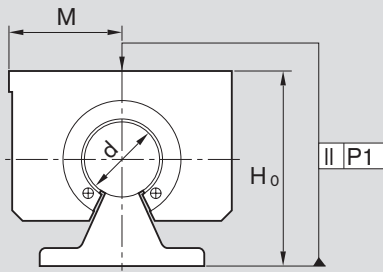

Tolerances ⁵⁾ [μm]	Tolerance zone of shaft	ShaftØ d [mm]			
		20	30	40	60
Dimension H ₀ ^{3) 6)}	h6	+18 -39	+18 -39	+18 -42	+18 -45
	h7	+18 -47	+18 -47	+18 -51	+18 -56
Parallelism P1 ^{4) 6)}	h6	30	30	32	33
	h7	32	32	35	35

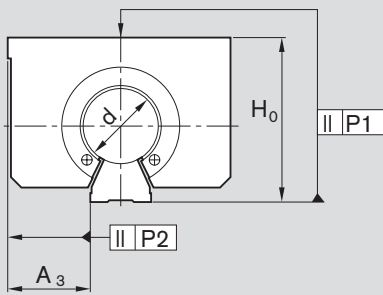

Tolerances ⁵⁾ [μm]	Tolerance zone of shaft	ShaftØ d [mm]				
		20	25	30	40	50
Dimension H ₀ ³⁾ Several support rails	h6	+28 -69	+28 -69	+28 -69	+28 -72	+28 -72
	h7	+28 -77	+28 -77	+28 -77	+28 -81	+28 -81
Dimension H ₀ ³⁾ Single support rail	h6	57	57	57	60	60
	h7	65	65	65	67	69
Parallelism P1 ⁴⁾ Support rails in a row	h6	30	30	30	32	32
	h7	32	32	32	35	35
Parallelism P1 ⁴⁾ Single support rail	h6	20	20	20	22	22
	h7	22	22	22	25	25
Parallelism P2 ⁴⁾ Support rails in a row	h6	45	45	45	46	46
	h7	46	46	46	48	48
Parallelism P2 ⁴⁾ Single support rail	h6	15	15	15	16	16
	h7	16	16	16	18	18
Dimension A ₃ ³⁾	h6	+30 -37	+30 -37	+30 -37	+30 -38	+30 -38
	h7	+30 -41	+30 -41	+30 -41	+30 -43	+30 -43

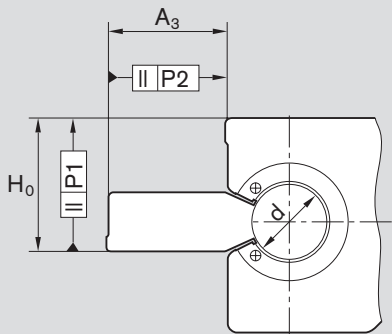
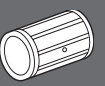

Tolerances ⁵⁾ [μm]	Tolerance zone of shaft	ShaftØ d [mm]				
		20	25	30	40	50
Dimension H ₀ ^{3) 6)}	h6	+20 -35	+20 -35	+20 -35	+20 -36	+20 -36
	h7	+20 -39	+20 -39	+20 -39	+20 -41	+20 -41
Dimension A ₃ ³⁾	h6	+20 -33	+20 -33	+20 -33	+21 -37	+21 -37
	h7	+20 -41	+20 -41	+20 -41	+21 -46	+21 -46
Parallelism P1 ^{4) 6)}	h6	29	29	29	30	30
	h7	30	30	30	32	32
Parallelism P2 ^{4) 6)}	h6	29	29	29	34	34
	h7	31	31	31	37	37

³⁾ Measured at center of housing

⁴⁾ When screwed to base mounting surface

⁵⁾ Tolerances valid for set with shaft and shaft support rail

⁶⁾ Shaft support single, several or in a row

Linear Sets with Super Linear Bushings **HL** or **SHL**

Linear sets, R1701
closed type

Linear sets, R1702
adjustable

Structural design

- Precision Housing (Aluminum)
- Super Linear Bushing **HL** or **SHL**
- Self-adjusting to 30'
- Fully sealed
- Retention by means of a screw
- Easy re-lubrication

For precise values for the 4 main directions of load see "Technical Data – Load capacity factors".

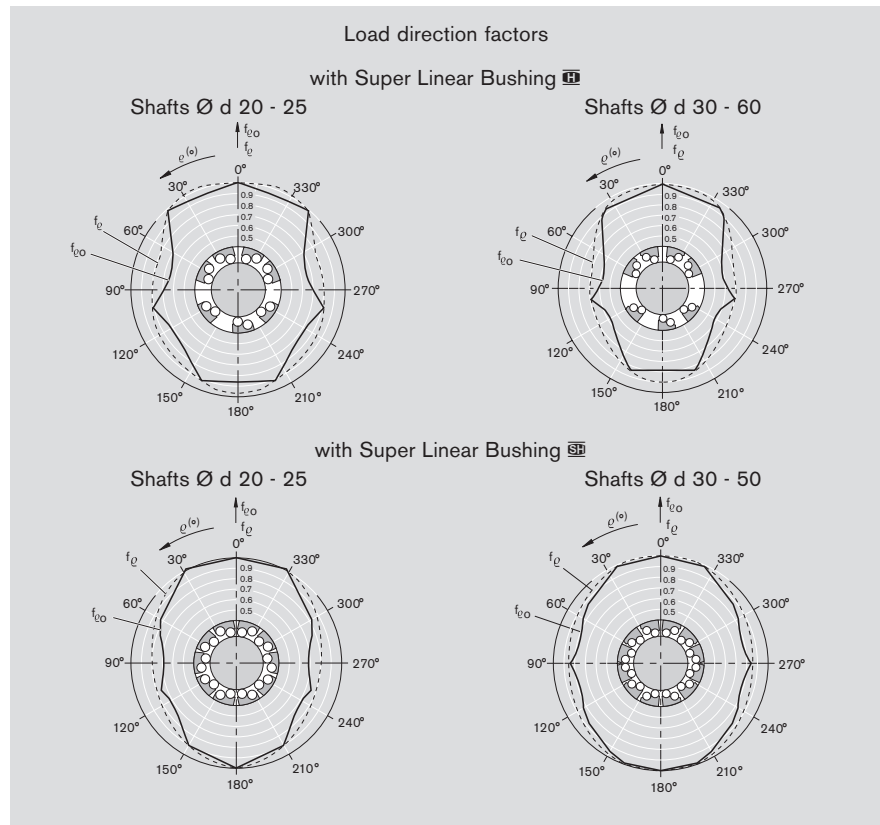

Shaft Ø d [mm]	Part numbers with Super Linear Bushing		Mass [kg]	
	HL	SHL	HL	SHL
20	R1701 220 20	R1701 420 20	0.29	0.31
25	R1701 225 20	R1701 425 20	0.58	0.63
30	R1701 230 20	R1701 430 20	0.88	0.97
40	R1701 240 20	R1701 440 20	1.63	1.86
50	R1701 250 20	R1701 450 20	2.70	3.10
60	R1701 260 20	–	5.20	–

Shaft Ø d [mm]	Part numbers with Super Linear Bushing		Mass [kg]	
	HL	SHL	HL	SHL
20	R1702 220 20	R1702 420 20	0.29	0.31
25	R1702 225 20	R1702 425 20	0.58	0.63
30	R1702 230 20	R1702 430 20	0.88	0.97
40	R1702 240 20	R1702 440 20	1.63	1.86
50	R1702 250 20	R1702 450 20	2.70	3.10
60	R1702 260 20	–	5.20	–

Dimensions

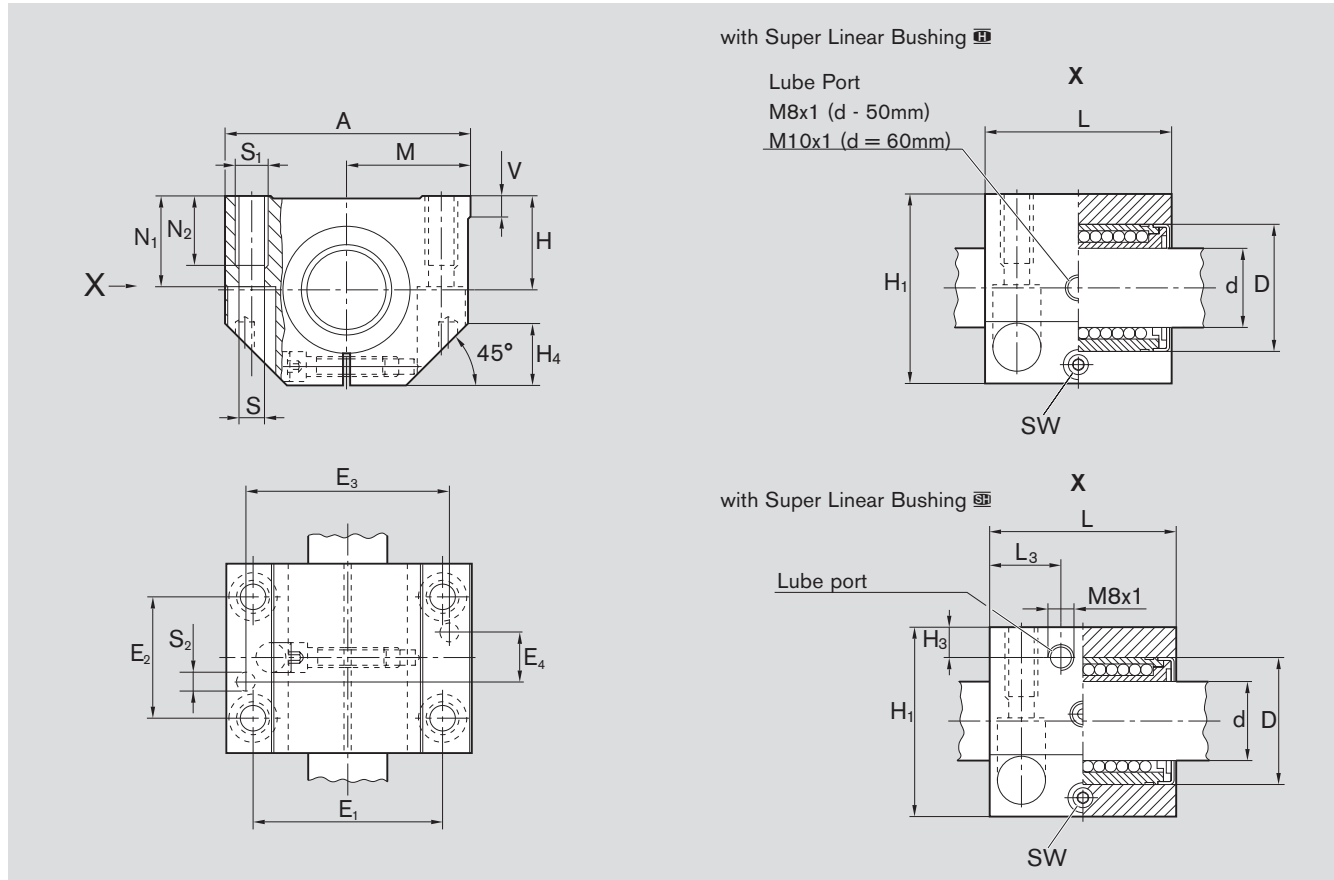

Ø d	D	Dimensions [mm]																			
		H ¹⁾	H ₁	M ¹⁾	A	L	E ₁	E ₂	E ₃	E ₄	S	S ₁	S ₂	N ₁	N ₂	H ₃	L ₃	V	SW	H ₄	
	+0.008 -0.016			±0.01																	
20	32	25	50	30	60	46	45±0.15	32±0.15	50	15	6.6	M8	5	24	18	10	16	5	4	16	
25	40	30	60	39	78	59	60±0.15	40±0.15	64	17	8.4	M10	6	29	22	10	21	6.5	5	20	
30	47	35	70	43.5	87	69	68±0.15	45±0.15	72	20	8.4	M10	6	34	22	11.5	26	8	5	22	
40	62	45	90	54	108	81	86±0.15	58±0.15	90	25	10.5	M12	8	44	26	14	30	10	6	28	
50	75	50	105	66	132	101	108±0.20	50±0.20	108	35	13.5	M16	10	49	34	12.5	39	12	8	37	
60	90	60	125	82	164	126	132±0.20	65±0.20	132	45	17.5	M20	12	59	42	-	-	13	10	45	

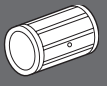

Shaft Ø d [mm]	Radial clearance ²⁾ [µm]		Load capacity ³⁾ [N]			
	R1701 Shaft	R1702	with Super Linear Bushing Ⓛ		Ⓜ	
	h6	h7	dyn. C	stat. C ₀	dyn. C	stat. C ₀
20	+43	+49	2520	1880	3530	2530
	+11	+13				
25	+43	+49	4430	3360	6190	4530
	+11	+13				
30	+43	+49	6300	5230	8800	7180
	+11	+13				
40	+50	+57	9680	7600	13500	10400
	+12	+14				
50	+50	+57	16000	12200	22300	16800
	+12	+14				
60	+56	+65	23500	18700	-	-
	+14	+16				

adjusted to zero clearance on h5 shaft (lower limit) prior to delivery

- 1) When screwed down, relative to shaft nominal dimension d.
- 2) When screwed down.
- 3) Caution:
Reduction in load capacity due to load direction (see "Technical Data").
The figures given for load capacity are maximum values as the position and load direction can be precisely defined.

The figures for dynamic load-carrying capacity have been calculated assuming a nominal travel of 100,000 m. For a nominal travel of 50,000 m, the 'C' figures in the table must be multiplied by a factor of 1.26.

Linear Sets with Super Linear Bushings **SI** or **SP**

Linear sets, R1703
open

Linear sets, R1704
open, adjustable

Structural design

- Precision Housing (Aluminum)
- Super Linear Bushing **SI** or **SP**
- Self-adjusting to 30'
- Fully sealed
- Retention by means of a screw
- Easy re-lubrication

For precise values for the 4 main directions of load see "Technical Data – Load capacity factors".

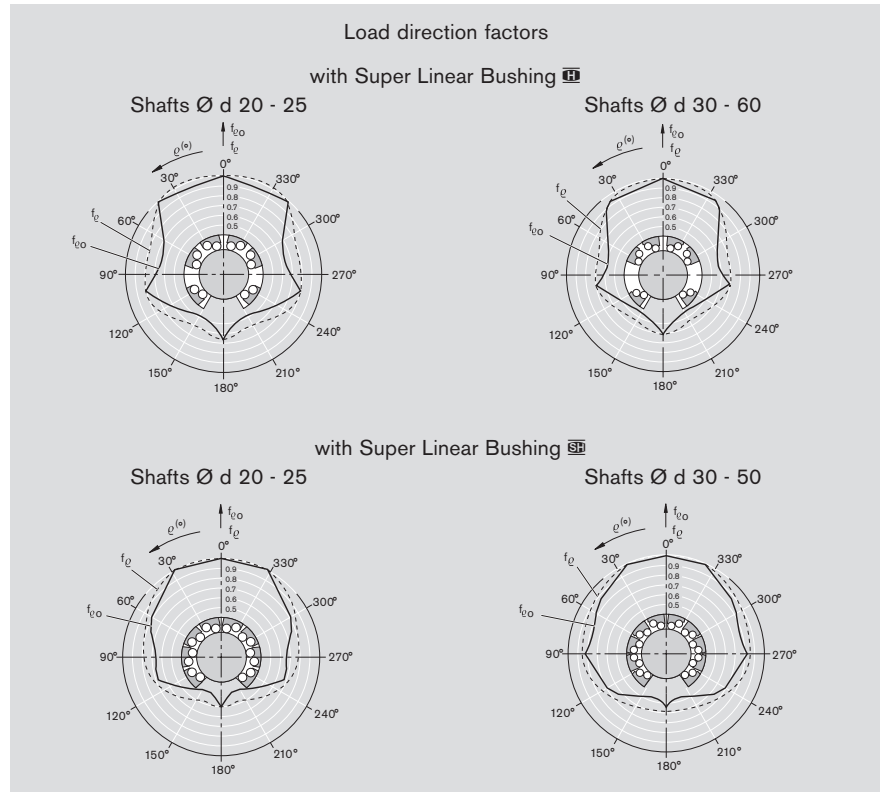

Shaft $\varnothing d$ [mm]	Part numbers with Super Linear Bushing		Mass [kg]	
	SI	SP	SI	SP
20	R1703 220 70	R1703 420 70	0.24	0.26
25	R1703 225 70	R1703 425 70	0.48	0.51
30	R1703 230 70	R1703 430 70	0.72	0.79
40	R1703 240 70	R1703 440 70	1.38	1.56
50	R1703 250 70	R1703 450 70	2.30	2.60
60	R1703 260 70	-	4.40	-



Shaft $\varnothing d$ [mm]	Part numbers with Super Linear Bushing		Mass [kg]	
	SI	SP	SI	SP
20	R1704 220 70	R1704 420 70	0.24	0.26
25	R1704 225 70	R1704 425 70	0.48	0.51
30	R1704 230 70	R1704 430 70	0.72	0.79
40	R1704 240 70	R1704 440 70	1.38	1.56
50	R1704 250 70	R1704 450 70	2.30	2.60
60	R1704 260 70	-	4.40	-

Dimensions

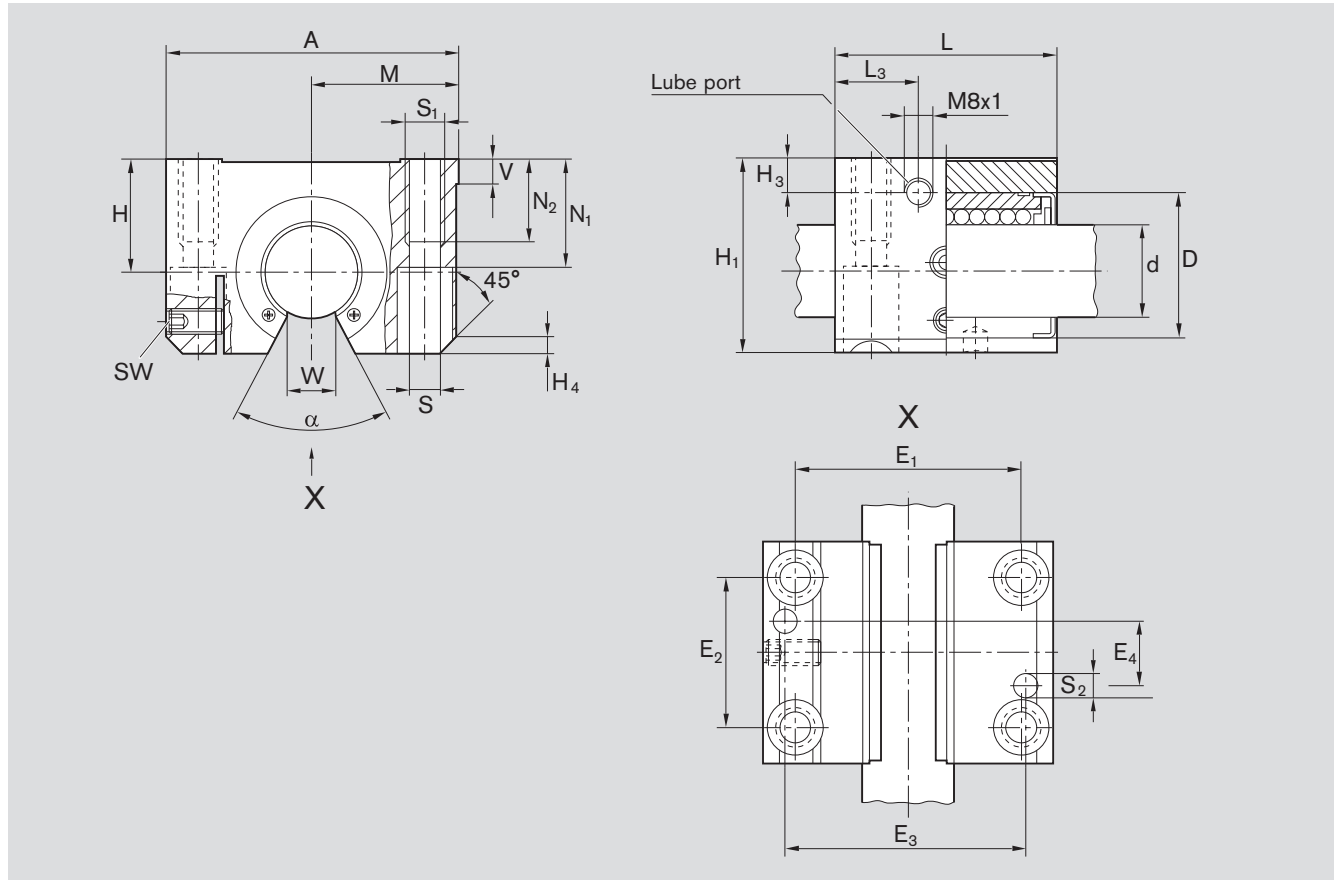

Dimensions [mm]																					
Ø d	D	H ¹⁾	H ₁	M ¹⁾	A	L	E ₁	E ₂	E ₃	E ₄	S	S ₁	S ₂	N ₁	N ₂	H ₃	L ₃	V	SW	W	H ₄
		+0.008		±0.01																	
		-0.016																			
20	32	25	42	30	60	46	45±0.15	32±0.15	50	15	6.6	M8	5	24	18	10	16	5	2.5	9.5	3.5
25	40	30	51	39	78	59	60±0.15	40±0.15	64	17	8.4	M10	6	29	22	10	21	6.5	3	12	4
30	47	35	60	43.5	87	69	68±0.15	45±0.15	72	20	8.4	M10	6	34	22	11.5	26	8	3	12.8	6
40	62	45	77	54	108	81	86±0.15	58±0.15	90	25	10.5	M12	8	44	26	14	30	10	4	16.8	6
50	75	50	88	66	132	101	108±0.20	50±0.20	108	35	13.5	M16	10	49	34	12.5	39	12	5	22.1	6
60	90	60	105	82	164	126	132±0.20	65±0.20	132	45	17.5	M20	12	59	42	15	50	13	6	27	5

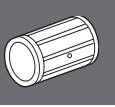

Shaft Ø d	Angle α	Radial clearance ²⁾ [µm]		Load capacity ³⁾ [N]			
		R1703	R1704	with Super Linear Bushing			
[mm]	[°]	h6	h7	dyn. C		stat. C ₀	
20	54	+31	+37	2520	3530	1880	2530
25	55	+31	+37	4430	6190	3360	4530
30	60	+31	+37	6300	8800	5230	7180
40	60	+35	+42	9680	13500	7600	10400
50	52	+35	+42	16000	22300	12200	16800
60	55	+39	+47	23500	-	18700	-

adjusted to zero clearance on h5 shaft (lower limit) prior to delivery

1) When screwed down, relative to shaft nominal dimension d.
 2) When screwed down.
 3) Caution:
 Reduction in load capacity due to load direction (see "Technical Data").
 The figures given for load capacity are valid for the main direction of load $\varrho = 0^\circ$.

The figures for dynamic load-carrying capacity have been calculated assuming a nominal travel of 100,000 m. For a nominal travel of 50,000 m, the 'C' figures in the table must be multiplied by a factor of 1.26.

Linear Sets with Super Linear Bushings **SI** or **SE**

Linear sets, R1706
with side opening, adjustable

Structural design

- Precision Housing (Aluminum)
- Super Linear Bushing **SI** or **SE**
- Self-adjusting to 30'
- Fully sealed
- Retention by means of a screw
- Easy re-lubrication

For precise values for the 4 main directions of load see "Technical Data – Load capacity factors".

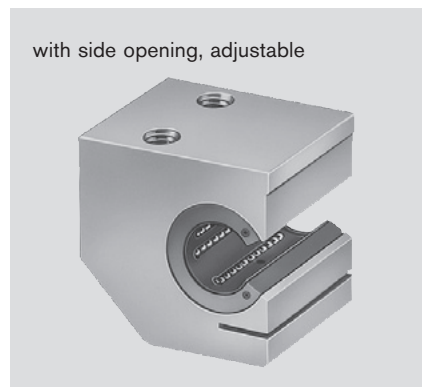
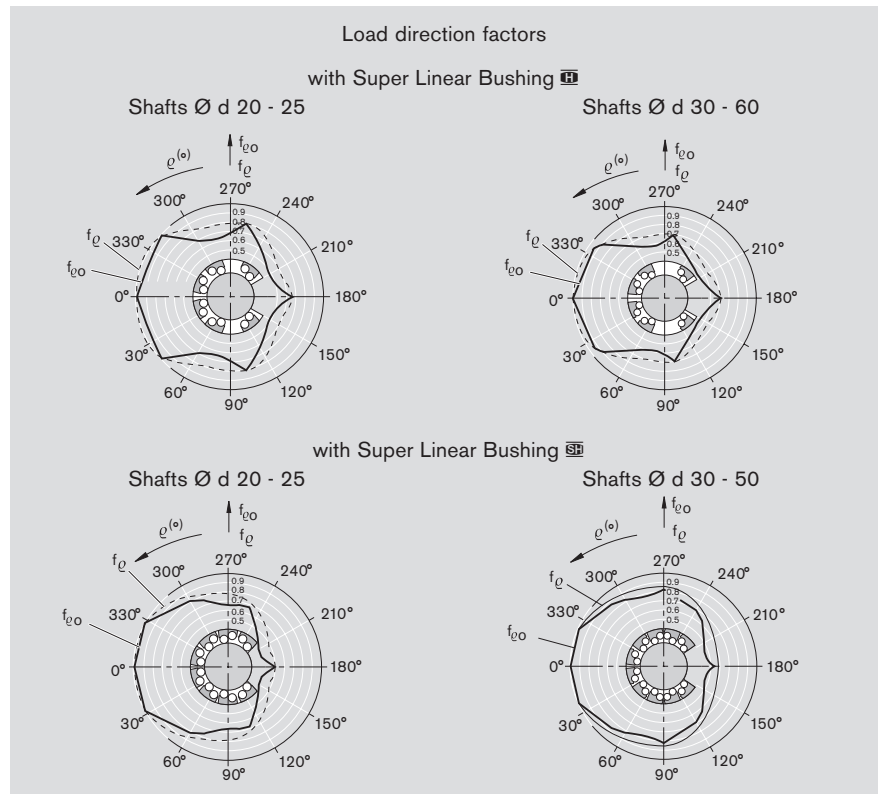

Shaft Ø d [mm]	Part numbers with Super Linear Bushing		Mass [kg]	
	SI	SE	SI	SE
20	R1706 220 70	R1706 420 70	0.35	0.37
25	R1706 225 70	R1706 425 70	0.70	0.73
30	R1706 230 70	R1706 430 70	1.03	1.10
40	R1706 240 70	R1706 440 70	1.80	1.95
50	R1706 250 70	R1706 450 70	3.00	3.25

Dimensions

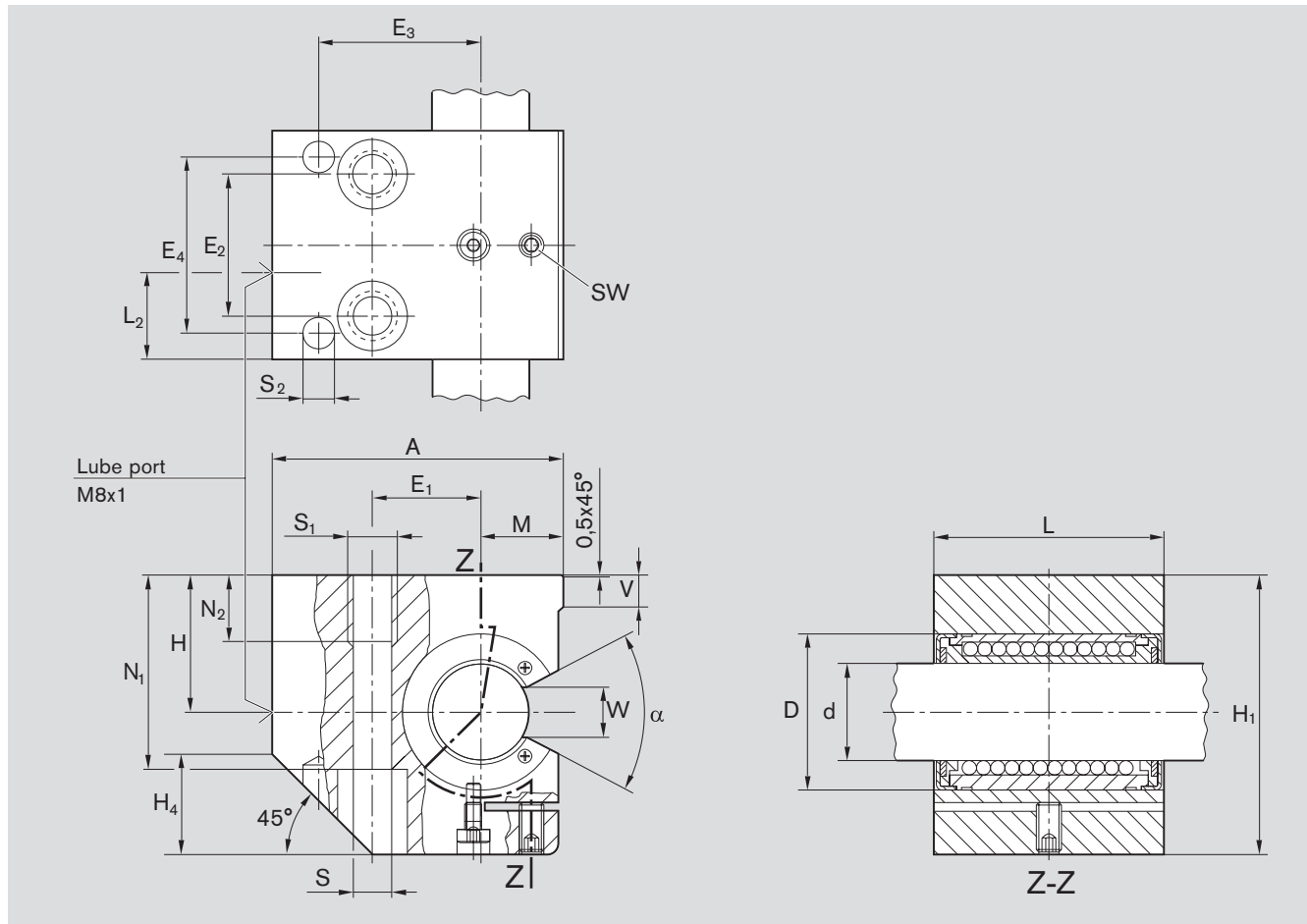

Dimensions [mm]																				
Ø d	D	H ¹⁾	H ₁	M ¹⁾	A	L	E ₁	E ₂	E ₃	E ₄	S	S ₁	S ₂	N ₁	N ₂	L ₂	V	SW	W	H ₄
		+0.008		±0.01																
		-0.016																		
20	32	30	60	17	60	47	22±0.15	30±0.15	35	35	8.4	M10	6	42	15	17.5	5	2.5	9.5	22
25	40	35	72	21	75	59	28±0.15	36±0.15	42	45	10.5	M12	8	50	18	22	6.5	3	12	26
30	47	40	82	25	86	69	34±0.15	42±0.15	52	52	13.5	M16	10	55	24	27	8	3	12.8	30
40	62	45	100	32	110	81	43±0.15	48±0.15	65	60	15.5	M20	12	67	30	31	10	4	16.8	38
50	75	50	115	38	127	101	50±0.15	62±0.15	75	75	17.5	M20	12	78	30	39	12	5	22.1	45

Shaft Ø d	Angle α	Radial clearance ²⁾ [µm]	Load capacity ³⁾ [N]			
			with Super Linear Bushing			
[mm]	[°]		dyn. C		stat. C ₀	
20	54	adjusted to zero clearance on h5 shaft (lower limit) prior to delivery	2520	1880	3530	2530
25	55		4430	3360	6190	4530
30	60		6300	5230	8800	7180
40	60		9680	7600	13500	10400
50	52		16000	12200	22300	16800

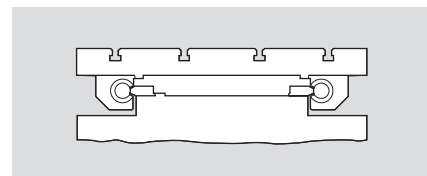

The figures for dynamic load-carrying capacity have been calculated assuming a nominal travel of 100,000 m. For a nominal travel of 50,000 m, the 'C' figures in the table must be multiplied by a factor of 1.26.

- 1) When screwed down, relative to shaft nominal dimension d.
- 2) When screwed down.
- 3) Caution:
Reduction in load capacity due to load direction (see "Technical Data").
The figures given for load capacity are valid for the main direction of load $\varrho = 0^\circ$.

Radial Linear Bushings, Radial Compact sets

The advantages

- High precision Linear Bushing for very high load capacity
- Radial ball return for especially high number of bearing rows and highest capacity
- Higher rigidity
- Quieter operation
- Fully sealed or without seals
- Heavy load guidance with a degree of freedom in circumferential direction
- For applications where inexact substructures could lead to preload variations
- Linear sets with steel housing
- Radial Compact sets for very compact construction



Radial Linear Bushings



Radial Compact set open type



Radial Compact set open, adjustable

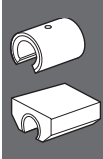

Radial Linear Bushings

Technical Data

Please observe the general technical principles and mounting instructions at the beginning of this catalog as well as the additional technical data given below.

Sealing

Radial Linear Bushings can be supplied

- fully sealed with internal wiper-type seals and axial seal strip, or
- with separate seals specially designed for use with Radial Linear Bushings.

Friction

The coefficient of friction μ of unsealed Radial Linear Bushings lies between 0.001 and 0.002. This low friction coefficient makes it possible to move heavy loads with a minimum of power consumption.

Radial Linear Bushings with separate seals or fully sealed achieve the following friction ratings:

Shaft $\varnothing d$ [mm]	Separate Seals		Fully Sealed	
	Breakaway force [N] ca.	Frictional drag [N] ca.	Breakaway force [N] ca.	Frictional drag [N] ca.
30	24	8	24	12
40	32	11	32	16
50	40	14	40	20
60	48	16	48	24
80	60	20	60	30

Velocity

$$v_{\max} = 2 \text{ m/s}$$

Acceleration

$$a_{\max} = 50 \text{ m/s}^2$$

Operating Temperature

-20 °C to 100 °C

separate Seals -20 °C to 80 °C, brief peaks up to 100 °C

Direction of load and its influence on the load capacity

The load capacity ratings C and C_0 given for Radial Linear Bushings apply when the load is acting along the line $\varrho = 0^\circ$. If the external load acts at an angle $\varrho = 90^\circ$ to 270° , allowance must be made for a reduction in load capacity by multiplying the load capacities C and C_0 by the load capacity factors f_ϱ and f_{ϱ_0} .

The reduction in the load capacity can be minimized by selective circumferential positioning of the Radial Linear Bushings.

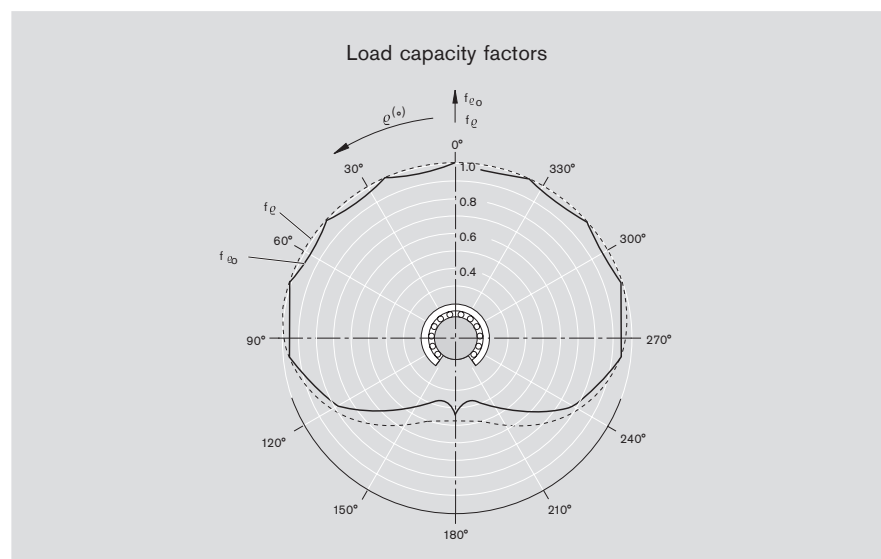

Rigidity

When used in conjunction with a continuously supported guide shaft Radial Linear Bushings constitute extremely accurate linear motion assemblies with a minimum of elastic deflection.

The chart below shows the elastic deflection of Radial Linear Bushings as a function of the load. The chart applies for installation under the following conditions:

- no preload
- zero clearance (no preload)
- for loads acting at angles of $\varrho = 0^\circ$ to 90° and 270° to 360° .

Rigidity of the Radial Linear Bushings

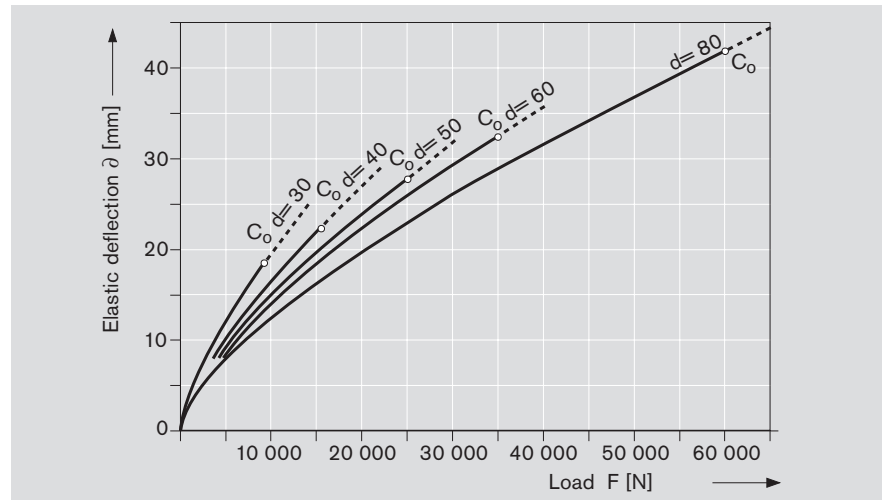

Mounting with preload reduces the elastic deflection. The additional elastic deflection of all other elements in the assembly (housing, shafts, shaft support rails) depends on the direction in which the load is acting.

Guide values for total elastic deflection: with elements R1075-/R1076 and R1018: Load direction factor multiplied by the elastic deflection Δ (see chart above).

Load direction ϱ	0°	90°	180°	270°
Elastic deflection	$1 \cdot \Delta$	$1.8 \cdot \Delta$	$3.5 \cdot \Delta$	$1.8 \cdot \Delta$

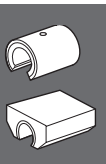

Radial Linear Bushings

Assembly, Retention

Installation, retention

For maximum rigidity, Radial Linear Bushings must be installed on continuously supported shafts. Our Linear Motion product range includes steel shaft support rails in standard lengths of 600 mm. The Radial Bushings must be inserted into the housings as described in the mounting procedure.

In applications where vibration or high acceleration rates are to be anticipated, and in particular for vertical installations, use of some additional means of retention is recommended.

The following assembly sequence should always be observed: first bolt the shafts to the shaft supports, then align the housings with the Radial Linear Bushings on the shafts, and only then bolt the assembly to the table.

Recommended tolerances

The tolerances for the housing bore can be taken from the table for Radial Linear Bushings. The housing may have a slot and adjusting screw at one side for establishing the desired clearance or preload. Radial Linear Bushings are also available as part of Linear Sets complete with matching housing. For details on permissible parallelism offset, please refer to the "General Technical Data and Mounting Instructions" at the beginning of this catalog.

Lubricating instructions

Lubricate only with shaft inserted; add lubricant until excess emerges. To prevent damage to the assembly during installation, it is essential that Radial

Procedure for mounting Radial Linear Bushings

Linear Bushings be inserted into the housing with the aid of a press or bearing extractor. The following instructions and illustrations should be observed during installation.

The outer sleeve of the Radial Linear Bushing and the surface of the mounting bore in the housing must be free from all oil residue before commencement of installation.

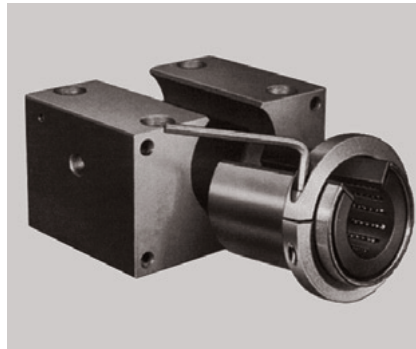

Slip a slotted mounting ring (order number 0940-0..-00) over the linear bushing as shown and reduce the outside diameter of the linear bushing by tightening the adjusting screw until it can easily be peared into the housing bore by hand. The bore of the mounting ring must be about 0.5 mm larger than the outside diameter D of the Radial

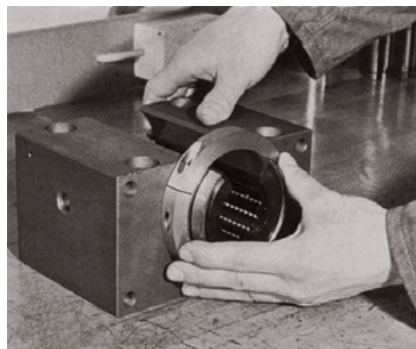

Linear Bushing.

After pushing the Radial Linear Bushing into the housing, but before loosening the mounting ring, match up the opening of the Radial Linear Bushing with the opening in the housing. The mounting ring can now be loosened.

¹⁾ Part number assembly ring: R0940 0.. 00

└── Shaft diameter

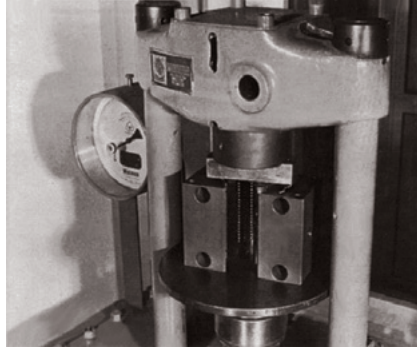

Use a press to push the pre-aligned Radial Linear Bushing firmly into the housing.

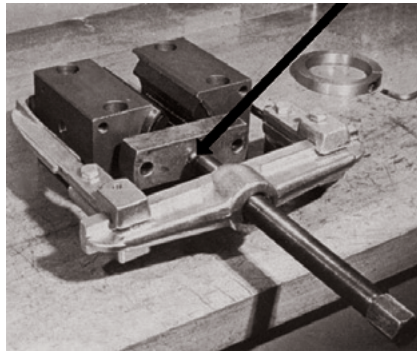

Alternatively, the pre-aligned Radial Linear Bushing can be pushed into the housing with the aid of a bearing extractor. In this case, the extractor spindle must be joined to the pressure plate via a ball bearing (see arrow). Otherwise, a separate thrust bearing must be provided in front of the extractor spindle to prevent the Radial Linear Bushing from being turned in the housing by torque exerted by the bearing extractor.

Notes

- If the openings of the Radial Linear Bushing and the housing do not match up when the linear bushing is mounted:
 - push out the Radial Linear Bushing (by means of the press or bearing extractor)
 - fit the mounting ring
 - correct the position of the linear bushing opening
 - continue the installation according to the photos and instructions above.
- The ends of the shaft must be chamfered.
- The Radial Linear Bushing must not be allowed to tilt while being pushed onto the shaft.
- Relative rotation between the shaft and the Radial Linear Bushing should be avoided.
- If external seals are used, these must be aligned with the Radial Linear Bushing and inserted by means of a press or bearing extractor.

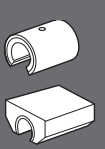

Radial Linear Bushings

Radial Linear Bushings, R0678
without seal or
fully sealed

Structural Design

- Hardened and ground steel sleeve
- Reinforced polyamide ball retainer
- Balls made of anti-friction bearing steel
- Two snap rings
- Without seals
- Fully sealed
- Separate Seals

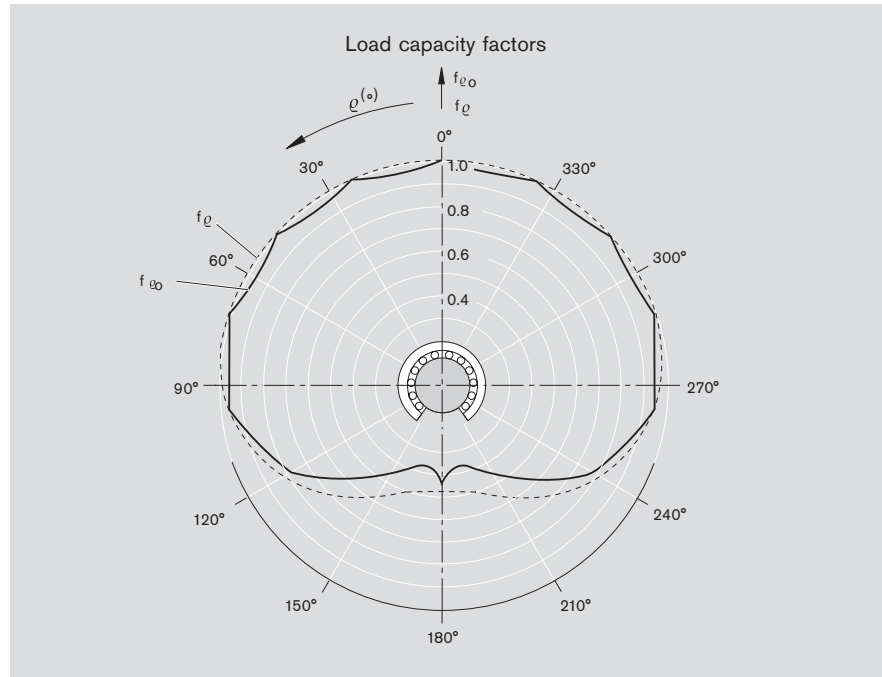

Shaft Ø d [mm]	Part numbers		Mass [kg]
	without seal	fully sealed	
30	R0678 030 00	R0678 230 45	0.7
40	R0678 040 00	R0678 240 45	1.4
50	R0678 050 00	R0678 250 45	2.5
60	R0678 060 00	R0678 260 45	4.9
80	R0678 080 00	R0678 280 45	10.4



Seals

Shaft Ø d [mm]	Part numbers	Mass [kg]
	Seals	
30	R1331 930 00	0,050
40	R1331 940 00	0,075
50	R1331 950 00	0,145
60	R1331 960 00	0,230
80	R1331 980 00	0,400

Dimensions

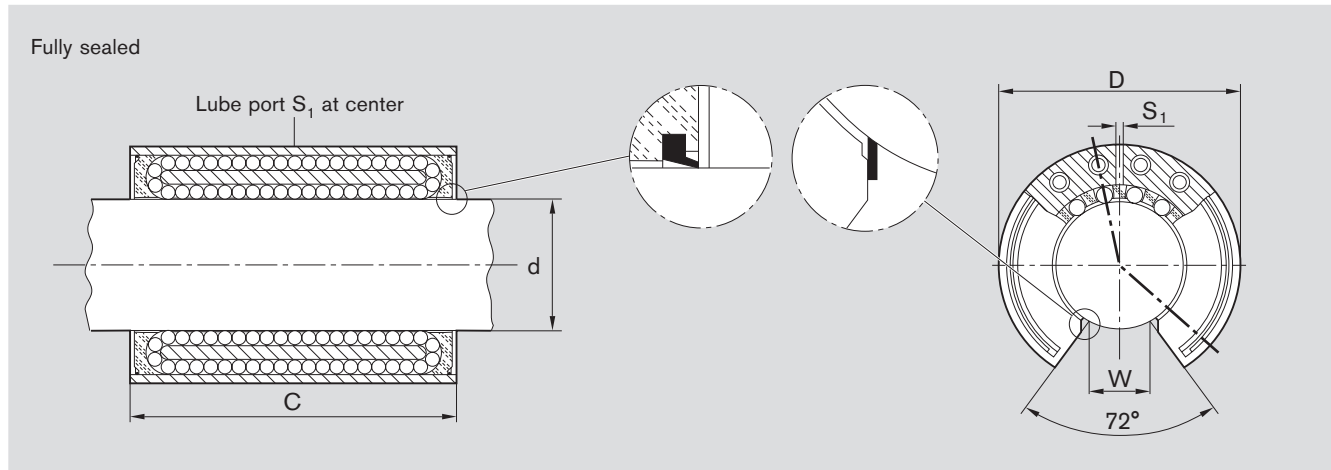

Ø d	D	Dimensions [mm]			No. of ball circuits	Radial clearance [µm]			Load capacities ³⁾ [N]	
		C h11	W ¹⁾	S ₁		h6/H6	h6/JS6 ²⁾	h6/K6 ²⁾	dyn. C	stat. C ₀
30	60	75	14	3	12	+21 -10	+12 -20	+6 -25	8500	9520
40	75	100	19,5	3	12	+23 -13	+13 -22	+8 -28	13900	16000
50	90	125	24,5	3	12	+25 -12	+14 -23	+7 -30	20800	24400
60	110	150	29	4	12	+26 -15	+15 -26	+8 -33	29500	34100
80	145	200	39	4	12	+29 -15	+16 -27	+8 -36	54800	61500

¹⁾ Caution: travel life may be shortened by excessive preload (see tables TB-06-052-05 and -06).

²⁾ Lower limit relative to shaft diameter d.

³⁾ The stated load capacities apply when the load is acting along the line $\varrho = 0^\circ$.

The figures for dynamic load-carrying capacity have been calculated assuming a nominal travel of 100,000 m. For a nominal travel of 50,000 m, the "C" figures in the table must be multiplied by a factor of 1.26.

Seals

Structural design

- Metal case
- Elastomer seal

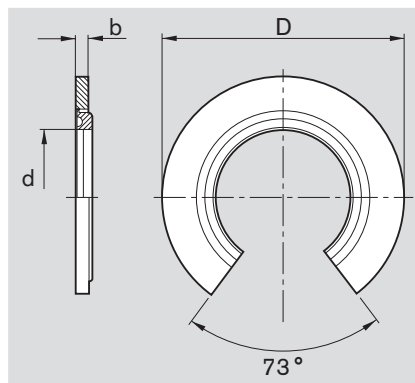

Dimensions [mm]		
Ø d	D ⁴⁾	b
30	60	5
40	75	5
50	90	7
60	110	7
80	145	7

⁴⁾ Outer diameter D is about 0.1 mm oversized. No retaining elements required except for applications subject to vibration or high acceleration.

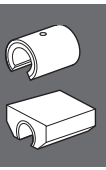

Linear sets with Radial Linear Bushings

Linear Sets, R1075
open type

Linear Sets, R1076
open type, adjustable

Structural Design

- Precision Housing (spheroidal graphite cast iron)
- Radial Linear Bushing
- Two seals
- Easy re-lubrication

Combined with Precision Steel Shafts and Shaft Support Rails, these Linear Sets provide linear motion assemblies of exceptional rigidity and with a high load-carrying capacity.

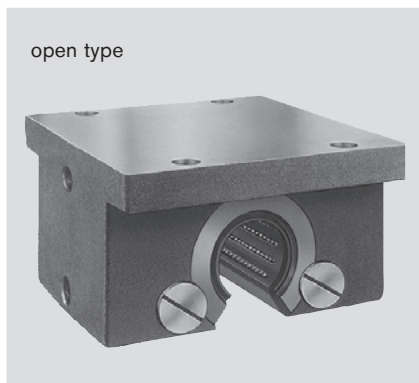
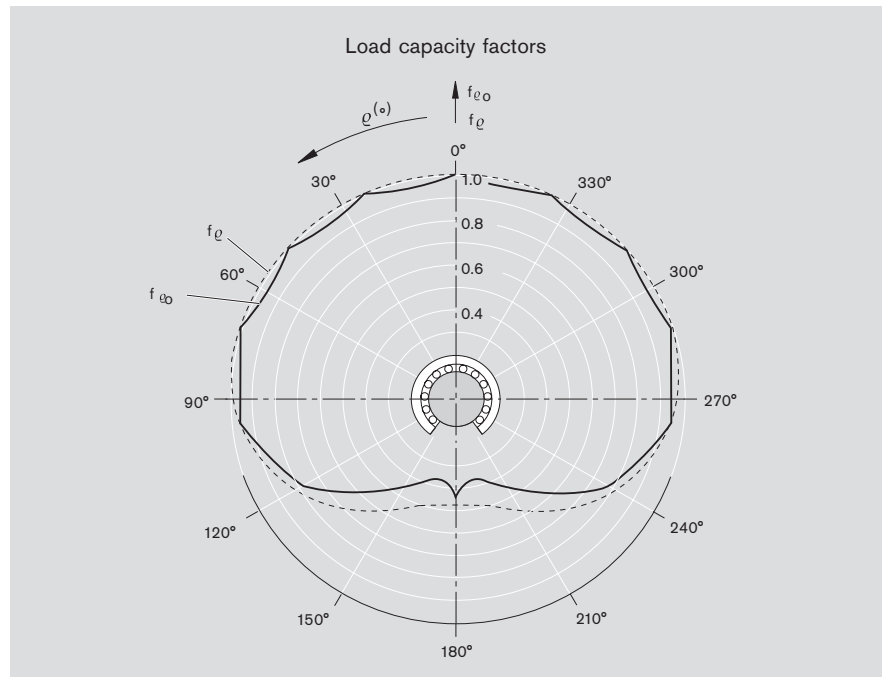

Shaft Ø d [mm]	Part numbers with two seals	Mass [kg]
30	R1075 230 20	6.1
40	R1075 240 20	11.8
50	R1075 250 20	19.7
60	R1075 260 20	38.4
80	R1075 280 20	76.1



Shaft Ø d [mm]	Part numbers with two seals	Mass [kg]
30	R1076 230 20	6,1
40	R1076 240 20	11,8
50	R1076 250 20	19,7
60	R1076 260 20	38,4
80	R1076 280 20	76,1

Dimensions

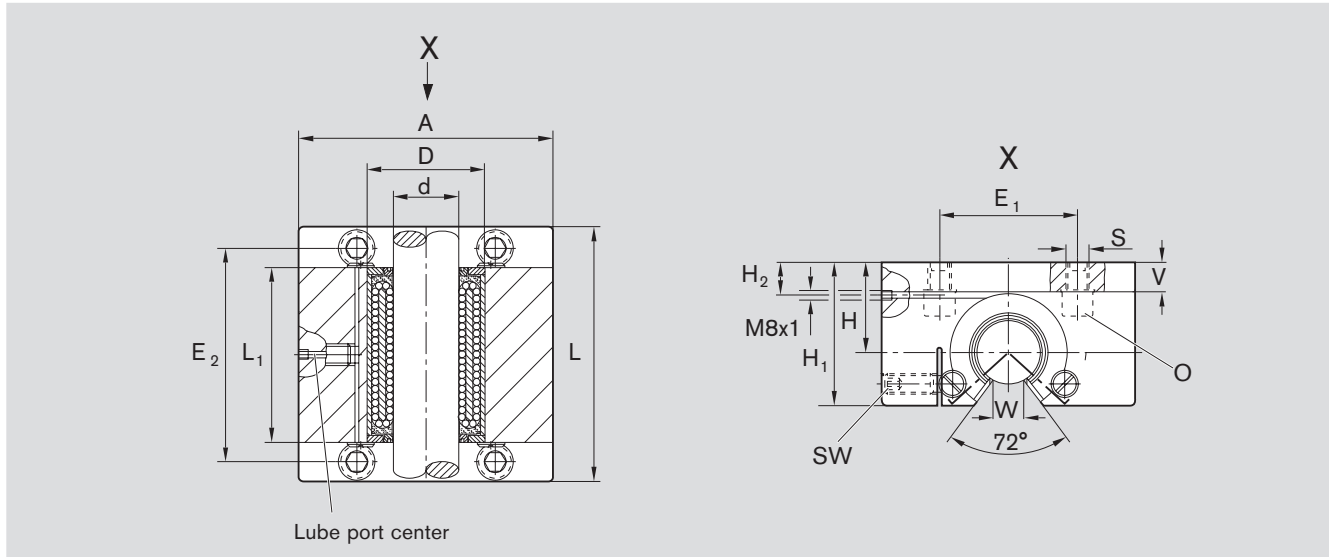

Dimensions [mm]															Radial clearance [μm]		Tolerance [μm] for dimension H ⁴⁾	Load capacities ⁵⁾ [N]	
Ø d	D	A ¹⁾	L ¹⁾	L ₁ +0,5	H	H ₁ ¹⁾	H ₂	V ¹⁾	E ₁ ±0,5	E ₂ ±0,5	S H13	W ²⁾	O ³⁾	SW	R1075 Shaft h6	R1076		dyn. C	stat. C ₀
30	60	140	130	84	48	75	18	16	75	108	11	14	M10x30	5	+21 -10	adjusted to zero clearance on h5 shaft (lower limit) prio to delivery	+15 -5	8500	9520
40	75	170	160	109	60	94	22,5	20	90	135	13,5	19,5	M12x40	6	+23 -13		+17 -4	13900	16000
50	90	200	200	138	70	110	25	23	110	170	17,5	24,5	M16x50	8	+25 -12		+18 -5	20800	24400
60	110	240	240	163	85	135	30	28	130	200	22	29	M20x60	10	+26 -15		+23 -4	29500	34100
80	145	310	310	213	110	175	37,5	35	170	260	26	39	M24x80	12	+29 -15		+22 -5	54800	61500

¹⁾ Hex. socket head cap screws to ISO 4762-8.8. Applies only to fixing in tapped bores in steel or cast iron.

²⁾ When screwed down, relative to shaft nominal dimension d.

³⁾ Tolerance to DIN 1685-GTB 16.

⁴⁾ Lower limit relative to shaft nominal diameter d.

⁵⁾ The stated load capacities apply when the load is acting along the line $\varrho = 0^\circ$.

The figures for dynamic load-carrying capacity have been calculated assuming a nominal travel of 100,000 m. For a nominal travel of 50,000 m, the "C" figures in the table must be multiplied by a factor of 1.26.

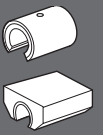

Linear sets with Radial Linear Bushings

Linear Sets, R1077
with side opening

Linear Sets, R1078
with side opening, adjustable

Structural Design

- Precision Housing with side opening (spheroidal graphite cast iron)
- Radial Linear Bushing
- Two seals
- Easy re-lubrication

The load carrying capacity of open linear bushings is considerably reduced when the load is applied to the "open" portion of the bushing.

This Linear Set has been developed to allow lateral installation of the Radial Linear Bushing and thus full utilization of the high load capacity rating.

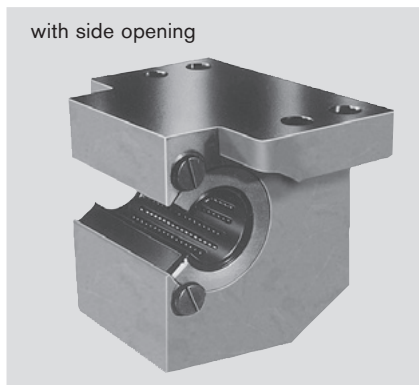
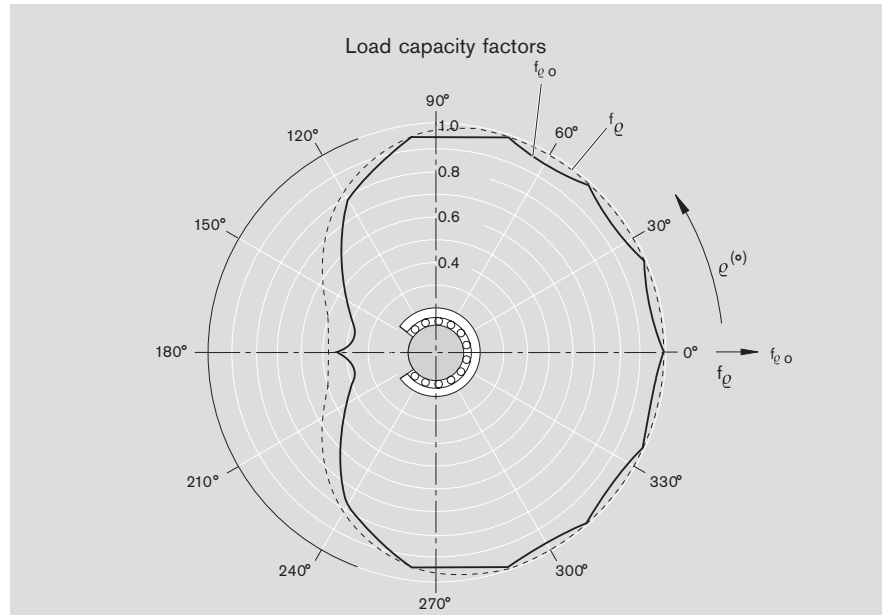

Shaft Ø d [mm]	Part numbers with two seals	Mass
		[kg]
30	R1077 230 20	7.8
40	R1077 240 20	15
50	R1077 250 20	27.5
60	R1077 260 20	48
80	R1077 280 20	105

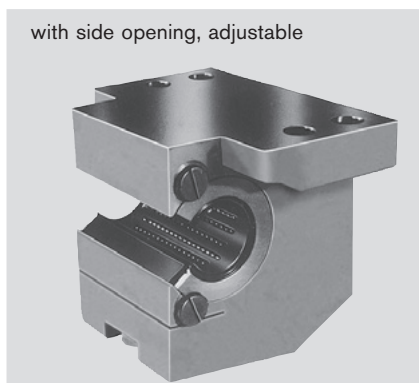

Shaft Ø d [mm]	Part numbers with two seals	Mass
		[kg]
30	R1078 230 20	7.8
40	R1078 240 20	15
50	R1078 250 20	27.5
60	R1078 260 20	48
80	R1078 280 20	105

Dimensions

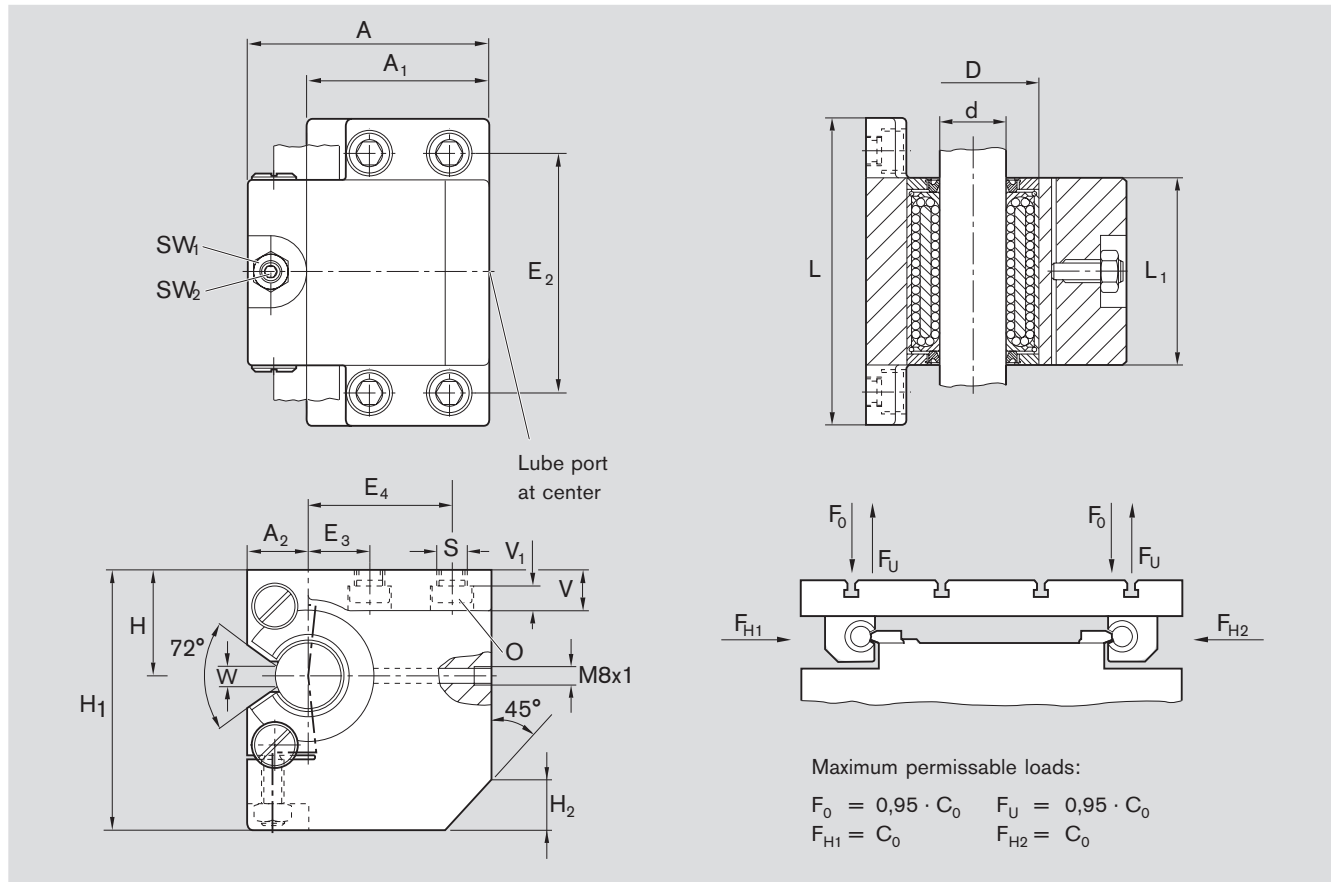

Dimensions [mm]																			
Ø d	D	A ¹⁾	A ₁ ¹⁾	A ₂ ¹⁾	L ¹⁾	L ₁	H ₂ ¹⁾	H	H ₁ ¹⁾	V ¹⁾	V ₁	E ₂	E ₃	E ₄	S	W ²⁾	SW ₁	SW ₂	O ³⁾
30	60	110	83	27	140	84	30	48	118	18	11	110	28	65	13.5	14	17	5	M12x30
40	75	135	100	35	180	109	35	60	145	25	15	142	40	76	17.5	19.5	19	6	M16x40
50	90	165	125	40	230	138	45	70	170	30	17.5	180	50	95	22	24.5	24	8	M20x50
60	110	200	150	50	275	163	55	85	205	35	20.5	215	60	115	26	29	30	10	M24x60
80	145	265	200	65	345	213	70	110	265	45	25.5	275	75	155	33	39	36	12	M30x80

The figures for dynamic load-carrying capacity have been calculated assuming a nominal travel of 100,000 m. For a nominal travel of 50,000 m, the 'C' figures in the table must be multiplied by a factor of 1.26.

Shaft Ø d [mm]	Radial clearance [µm]		Tolerance for dimension H ⁴⁾ [µm]	Load capacities ⁵⁾ [N]	
	R1077 Shaft h6	R1078		dyn. C	stat. C ₀
30	+21	adjusted to zero clearance on h5 shaft (lower limit) prior to delivery	+15	8500	9520
	-10		-5		
40	+23		+17	13900	16000
	-13		-4		
50	+25		+18	20800	24400
	-12		-5		
60	+26		+23	29500	34100
	-15		-4		
80	+29		+22	54800	61500
	-15		-5		

¹⁾ Tolerance to DIN 1685-GTB 16

²⁾ Hex. socket head cap screws to DIN 6912-8.8. Applies only for fixing in tapped bores in steel or cast iron.

³⁾ When screwed down, relative to shaft nominal dimension d.

⁴⁾ The load capacities apply when the load is acting along the line shown by the arrows at F_{H1} or F_{H2}.

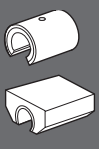

Radial Compact sets

Technical Data/Mounting

Friction, Velocity, Acceleration, Operating temperature and direction of load and its influence on the load capacity and rigidity.

The values given for Radial Linear Bushing may be used for design purposes.

Frictional drag for seals without radial loading

Shaft \varnothing d [mm]	Breakaway force [N] approx.	Frictional drag [N] approx.
30	24	12
40	32	16
50	40	20
60	48	24
80	60	30

Mounting procedure

Prior to installation

Check the flatness of the base on which the Radial Compact Set is to be mounted, as irregularities will affect the radial clearance. The shaft ends must be chamfered. Take care not to tilt the Radial Compact Sets while pushing them onto the shaft.

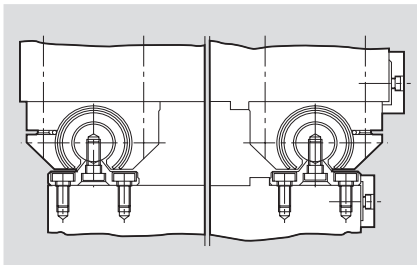

With Shaft Support Rails

see Chapter on "Shaft Support Rails".

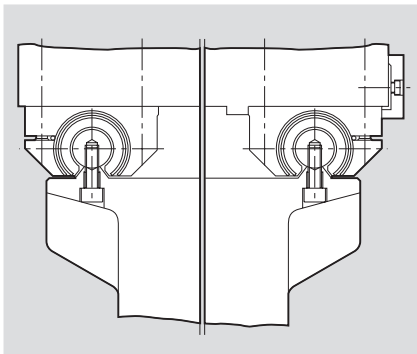

Shaft Support Rails cut to fit the machine base (low overall height)

- Fabricate the shaft support rails to the specified parallelism (see section on "Parallelism, General Technical Data and Mounting Instructions")
- Screw on the shafts
- Mount the Radial Compact Sets (see Chapter "Shaft Support Rails"). Alternatively, the Radial Compact Sets may be installed according to the Chapter "Shaft Support Rails"

Recommended mounting screws for installation of shaft

\varnothing d [mm]	ISO 4762-8.8
30	M10x30
40	M12x40
50	M16x50
60	M20x60
80	M24x80

Edge radii, fitting edges and screws

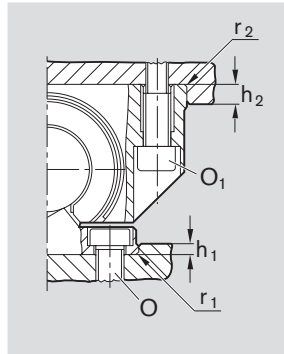

Ø d	Dimensions [mm]						Tightening torque [Nm]	
	r ₁	h ₁	r ₂	h ₂	O	O ₁	O	O ₁
	max		max		DIN 7984-8.8	ISO 4762-8.8		
30	0,6	6	0,6	6	M10x20	M10x40	32	46
40	0,6	6	0,6	6	M12x25	M12x45	56	80
50	1,2	8	0,6	8	M16x30	M16x60	136	195
60	1,2	8	0,6	16	M20x40	M20x80	270	385
80	1,2	10	0,6	20	M24x50	M24x100	460	660

Mounting of Radial Compact sets from below

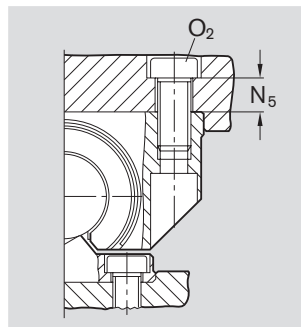

Ø d	Dimensions [mm]		Tightening torque [Nm]
	N ₅	O ₂ ISO 4762-8.8	
30	17	M12x30	55
40	24	M16x40	100
50	28	M20x50	240
60	30	M27x60	500
80	45	M30x80	800

Locating pins

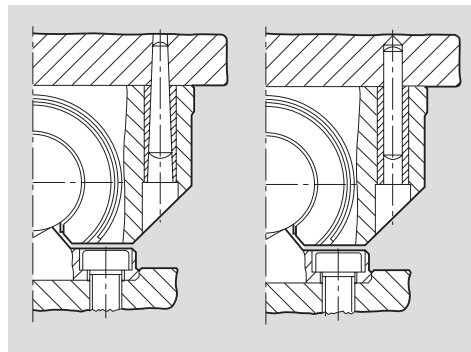

Ø d [mm]	Tapered pin (hardened) or cylindrical pin
30	8x60
40	10x80
50	12x100
60	14x120
80	16x160

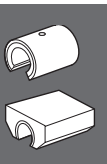

Radial clearance

Adjustable Radial Compact Sets are adjusted to zero clearance on a shaft of diameter accurate to a tolerance of h5 (lower limit) prior to delivery.

If a preload is required, the procedure is as follows:

- Measure the diameter of the guide shaft.
- Choose a dummy shaft whose diameter is smaller by the amount of the desired preload than the actual guide shaft and insert it.
- Reduce the clearance using the adjusting screw until a slight resistance is felt when the dummy shaft is turned.

Lubrication instructions

Lubricate only with shaft inserted; add lubricant until excess emerges.

Radial Compact sets

Radial-Compact sets, R1611
open type

Radial Compact sets, R1613
open type, adjustable

Structural Design

- Hardened and ground bearing block made of anti-friction bearing steel
- Reinforced polyamide ball retainer
- Balls made of anti-friction bearing steel
- Two snap rings
- Fully sealed (with internal wiper-type seals and seal strip)

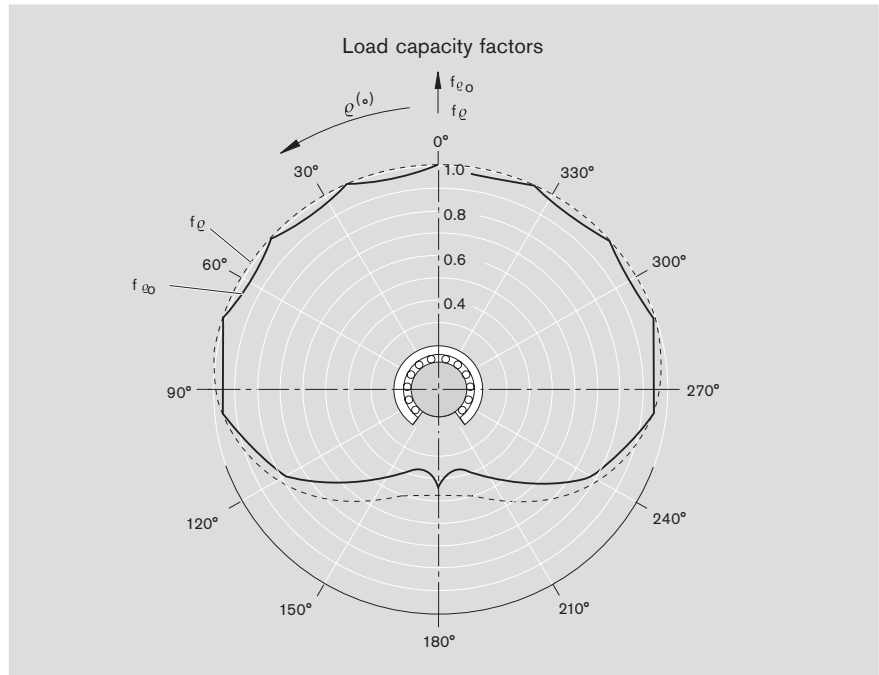

Shaft Ø d [mm]	Part numbers	Mass [kg]
30	R1611 300 00	1.75
40	R1611 400 00	3.5
50	R1611 500 00	7.1
60	R1611 600 00	11.9
80	R1611 800 00	29.6



Shaft Ø d [mm]	Part numbers	Mass [kg]
30	R1613 300 00	1.75
40	R1613 400 00	3.5
50	R1613 500 00	7.1
60	R1613 600 00	11.9
80	R1613 800 00	29.6

Dimensions

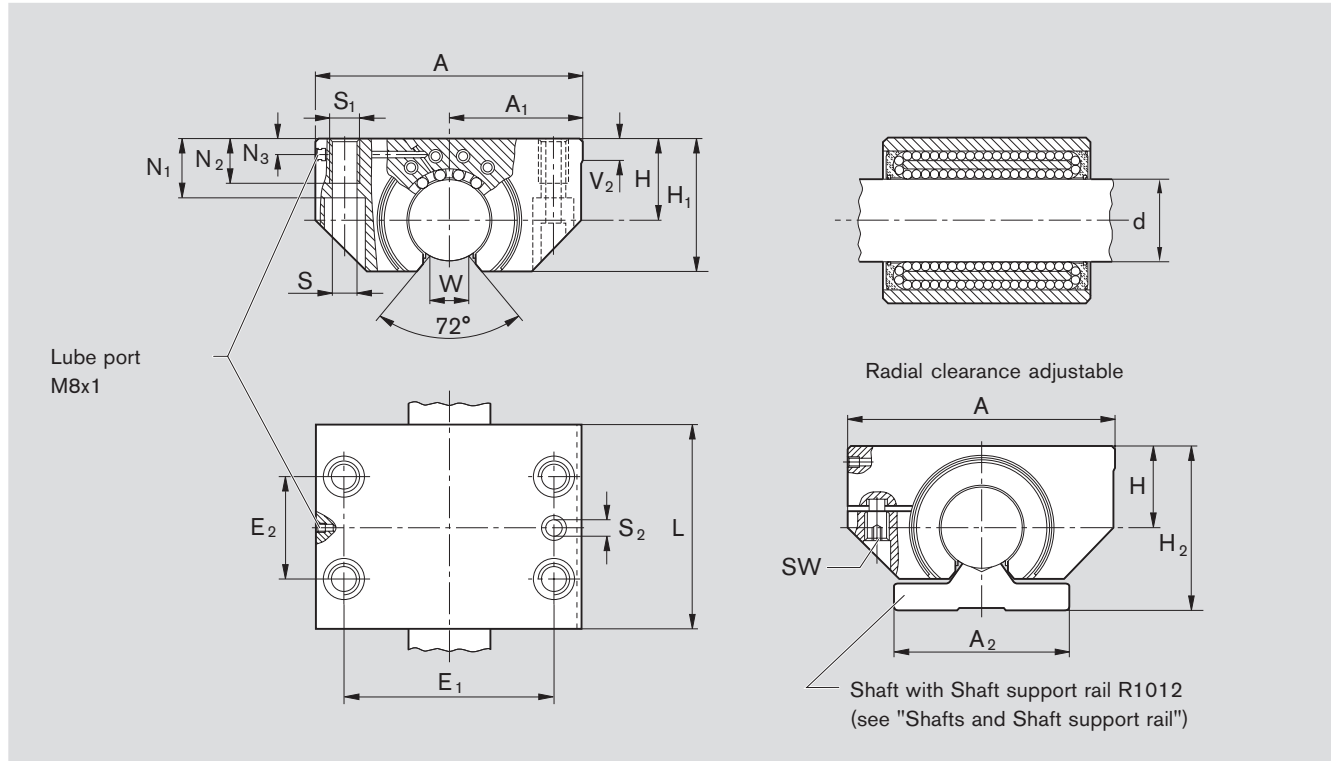

Ø d	Dimensions [mm]																	Radial clearance [µm] Shaft h6		Load capacities ⁴⁾ [N]			
	A	A ₁	A ₂	H ¹⁾	H ₁	H ₂	L	E ₁	E ₂	S	S ₁	S ₂ ²⁾	N ₁	N ₂	N ₃	V ₂	W ³⁾	SW	R1611	R1613	dyn. C	stat. C ₀	
30	100	50	68	32	53	65	75	76	40	10.5	M12	7.7	21	15	9	6	14	5	+10	-6	adjusted to zero clearance on h5 shaft (lower limit) prior to delivery	8500	9520
40	125	62.5	85	40	66	80	100	94	50	14	M16	9.7	27	18	11	6	19.5	6	+12	-7		13900	16000
50	160	80	105	50	81.5	100	125	122	65	17.5	M20	11.7	35	24	12	8	24.5	8	+12	-7		20800	24400
60	190	95	130	60	97	120	150	150	75	22	M27	13.7	42	32	13	16	29	10	+15	-9		29500	34100
80	260	130	170	80	130	160	200	205	100	26	M30	15.7	57	36	15	16	39	12	+15	-9		54800	61500

¹⁾ When screwed down, relative to shaft nominal dimension d.
²⁾ Pre-drilled bores for locating pins.
³⁾ Lower limit relative to shaft nominal dimension d.
⁴⁾ The load capacities apply when the load is acting along the line $\varrho = 0^\circ$.

The figures for dynamic load-carrying capacity have been calculated assuming a nominal travel of 100,000 m. For a nominal travel of 50,000 m, the 'C' figures in the table must be multiplied by a factor of 1.26.

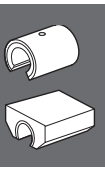

Torque-resistant Linear Bushings

The Advantages

- For axially and radially true linear motion with only one shaft
- With 1, 2 or 4 ball guide grooves for torque transfer
- Large choice of formats
- Torque-resistant Linear Bushings with adjustment screw set to zero-clearance at the factory
- Appropriate shaft profiles with ground ball guide grooves
- Shafts machined to customer specifications
- With separate seals or without seals
- Various flange formats
- With steel or aluminum housing in various formats

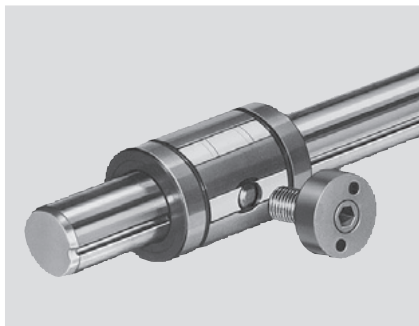

Torque-resistant-Linear Bushings Type 1 with one ball guide groove



Torque-resistant Linear Bushings Type 2 with two ball guide grooves

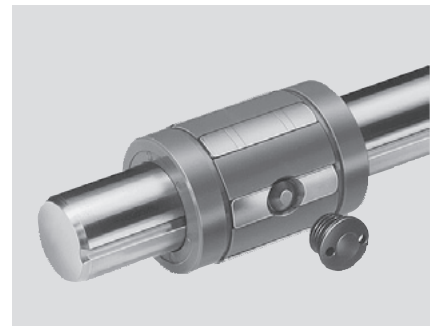

Torque-resistant Compact Linear Bushings



Torque-resistant Linear Bushings with four ball guide grooves

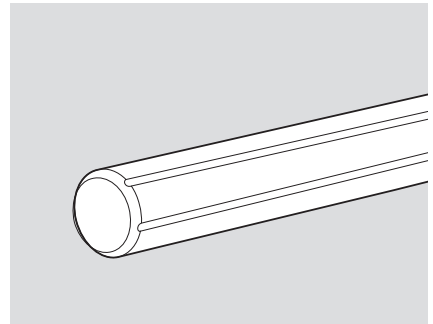

Precision steel shaft with four ball guide grooves

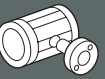

Torque-resistant Linear Bushings

Overview

Torque-resistant Linear Bushings

Type 1

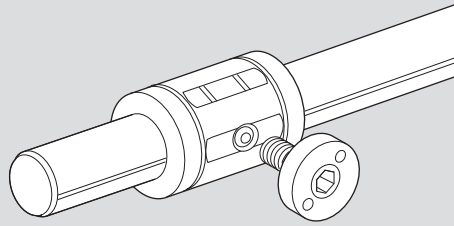

with one ball guide grooves

Type 2

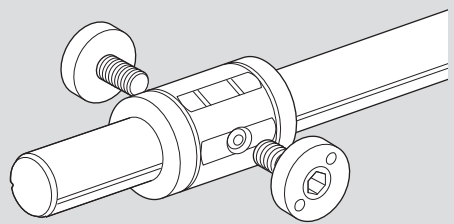

with two ball guide grooves

Torque-resistant Compact Linear Bushings

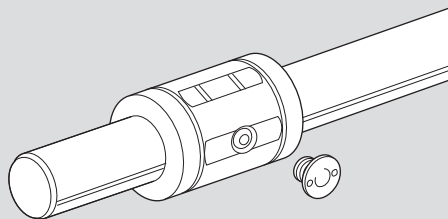

Technical Data

Please observe the general technical principles and mounting instructions at the beginning of this catalog as well as the additional technical data given below.

Operating temperature -20 °C to 100 °C

Reduced load capacity in short-stroke applications

In short-stroke applications, the service life of the shafts is shorter than that of the Torque-Resistant Linear Bushings.

For this reason, the load capacities C listed in the tables must be multiplied by the factor f_w .

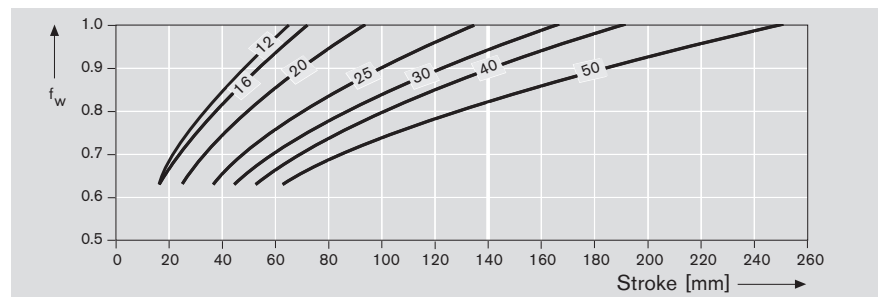

Load capacity and travel life

In applications subject to superimposed radial loads and torque, the equivalent total load must first be calculated for use in the travel life calculation.

$$F = F_R + \frac{C \cdot M}{M_t}$$

$$L = \left(\frac{C}{F}\right)^3 \cdot 10^5 \text{ m}$$

F	= equivalent total load (N)
F_R	= radial load (N)
C	= dynamic load capacity
M	= torque (Nm)
M_t	= torque (catalog rating) (Nm)
L	= travel life

In applications subject to torque only, travel life is calculated as follows:

$$L = \left(\frac{M_t}{M}\right)^3 \cdot 10^5 \text{ m}$$

$$M = \sqrt[3]{M_1^3 \cdot \frac{q_1}{100} + M_2^3 \cdot \frac{q_2}{100} + \dots + M_n^3 \cdot \frac{q_n}{100}}$$

M	= torque (Nm)
M_t	= torque (catalog rating) (Nm)
$M_1, M_2 \dots M_n$	= discrete torque step (Nm)
$q_1, q_2 \dots q_n$	= percentage stroke covered under $M_1, M_2 \dots M_n$ (%)

Straightness of shaft

- up to 1200 mm length: 0.1 mm
- at 2000 mm length: 0.2 mm

Stability against cocking loads

To ensure stability against cocking loads it is expedient to install two torque-resistant Linear Bushings.
In the case of Linear Sets, we recommend the Tandem version (with two torque-resistant Linear Bushings).

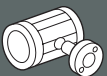

Torque-resistant Linear Bushings

Mounting of Torque-resistant Linear Bushings

Mounting procedure

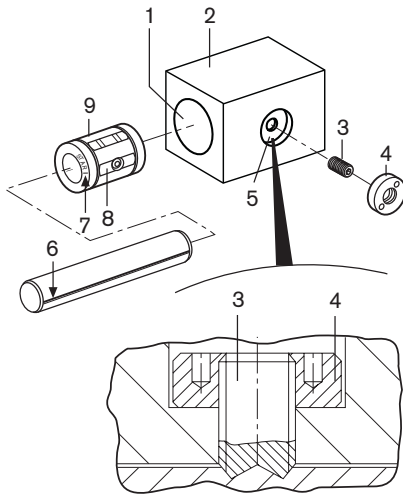

Linear Sets are ready-mounted and adjusted to zero clearance. If the shaft has been removed, it is necessary to loosen the adjusting screws and re-adjust the Torque-Resistant Linear Bushing.

- Chamfer and clean the bore (1) in the housing (2).
- Oil the adjusting screw (3).
- Check the lock nut (4) on the adjusting screw (3) for ease of movement.
- Check the adjusting screw (3) in the tapped hole (5) for ease of movement. Deburr thread runout, if necessary.
- Remove transport packing from the linear bushing.



Do not drive in linear bushings with a hammer!

- Insert linear bushing (9) in the housing (2) by hand.
- Align countersunk steel bearing plate (8) with the tapped hole (5) in the housing.
- Align one ball guide groove (6) with the marking (7) on the identification block of the linear bushing.

Adjustment of adjusting screws

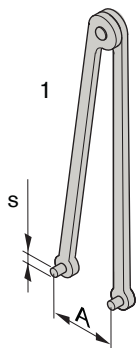

- Insert shaft, taking care not to tilt it!
- Screw in adjusting screw until it meets with initial resistance.
- Move shaft to and fro, while simultaneously attempting to turn it in both directions. Tighten adjusting screw with hex. wrench.
- For Type 1 (one ball guide groove), tighten adjusting screw to M_{GA} .
- For Type 2 (two ball guide grooves), first tighten one adjusting screw to $M_{GA}/2$, then the other to M_{GA} .
- Secure adjusting screw with lock nut. Use face wrench (1). The adjusting screw must not turn when being secured with the lock nut. Tightening torque = M_{GK} .
- After mounting, the frictional drag F_R should be as shown in the table below. If the frictional drag varies significantly, loosen and re-adjust adjusting screws!
- **Do not remove shaft!**

Shaft diameter [mm]	Face wrench (1) [mm]		Tightening torque[Ncm]		Frictional drag F_R ca. (one Linear Bushing) [N]
	s	A	adjusting screw M_{GA}	lock screw M_{GK}	
12	2,5	10	8	400	1,5
16	2,5	10	11	400	2
20	3	15	30	1500	3
25	3	15	45	1500	4,5
30	3	19,5	70	2000	6
40	3	19,5	100	2000	8
50	3	25	180	3000	12

Installation of seal

- Push seal onto the shaft, aligning the lip with the groove.
 - Press seal into the mounting bore.
- With each installed seal the frictional drag rises higher than the value F_R . If two seals are installed, it increases to roughly three times the value stated in the table.

Mounting Torque-resistant Compact Linear Bushings

Mounting procedure

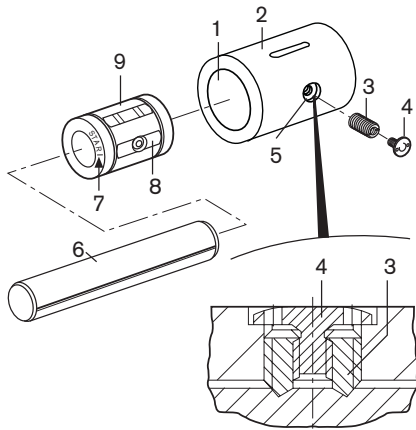

Linear Sets are ready-mounted and adjusted to zero clearance. If the shaft has been removed, it is necessary to loosen the adjusting screws and re-adjust the Torque-Resistant Compact Linear Bushing.

- Chamfer and clean the bore (1) in the housing (2).
- Oil the adjusting screw (3) and lock screw (4).
- Check the lock screw (4) in the adjusting screw (3) for ease of movement.
- Check the adjusting screw (3) in the tapped hole (5) for ease of movement. Deburr thread runout, if necessary.
- Remove transport packing from the linear bushing.



Do not drive in linear bushings with a hammer!

- Insert linear bushing (9) in the housing (2) by hand.
- Align countersunk steel bearing plate (8) with the tapped hole (5) in the housing.
- Align one ball guide groove (6) with the marking (7) on the identification block of the linear bushing.
- **Insert shaft, taking care not to tilt it!**

Adjustment of adjusting screws

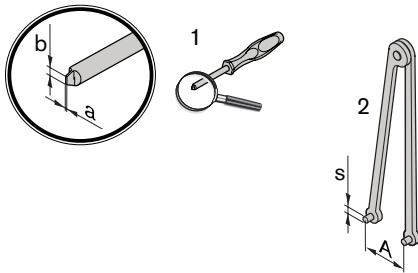

- Screw in adjusting screw until it meets with initial resistance.
- Move shaft to and fro, while simultaneously attempting to turn it in both directions. Tighten adjusting screw with screwdriver (1).
- For shaft diameters 12 and 16, tighten adjusting screw to M_{GA} .
- For shaft diameters 20 to 50, first tighten one adjusting screw to $M_{GA}/2$, then the other to M_{GA} .
- Using a face wrench (2), insert lock screw into the adjusting screw and tighten to tightening torque M_{GK} .
- After mounting, the frictional drag F_R should be as shown in the table below. If the frictional drag varies significantly, loosen and re-adjust adjusting screws!
- **Do not remove shaft!**

Shaft diameter [mm]	Screwdriver (1) [mm]		Face wrench (2) [mm]		Tightening torque [Ncm]		Frictional drag F_R ca. (one Linear Bushing) [N]
	a	b	s	A	adjusting screw M_{GA}	lock screw M_{GK}	
12	0.8	5	1.5	5,5	8	110	1,5
16	0.8	5	1.5	5,5	11	110	2
20	1	8	2	8	30	180	3,8
25	1	8	2	8	45	380	5,6
30	1.2	10	2.5	10	70	800	7,5
40	1.2	10	2.5	10	100	800	10
50	1.6	14	3	13	180	1300	15

Installation of seal

- Push seal onto the shaft, aligning the lip with the groove.
- Press seal into the mounting bore.
With each installed seal the frictional drag rises higher than the value F_R . If two seals are installed, it increases to roughly three times the value stated in the table.

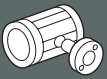

Torque-resistant Linear Bushings

Torque-resistant Linear Bushings, R0696 0..
Type 1: with one Ball guide groove

Torque-resistant Linear Bushings, R0696 3..
Type 2: with two ball guide grooves

Structural design

- Plastic ball retainer and outer sleeve
- Hardened steel load bearing plates
- Balls made of anti-friction bearing steel
- Precision Steel Shaft with ball guide groove
- Hardened steel adjusting screw
- Steel lock nut



Shaft Ø d [mm]	Part numbers torque-resistant Linear Bushings with shaft		
	Standard length per table	Shaft to specified length ¹⁾	Customized shaft
12	R0696 012 80	R0696 012 89	R0696 012 86
16	R0696 016 80	R0696 016 89	R0696 016 86
20	R0696 020 80	R0696 020 89	R0696 020 86
25	R0696 025 80	R0696 025 89	R0696 025 86
30	R0696 030 80	R0696 030 89	R0696 030 86
40	R0696 040 80	R0696 040 89	R0696 040 86
50	R0696 050 80	R0696 050 89	R0696 050 86

- 85 Shaft length 900 mm
- 87 Shaft length 1200 mm
- 88 Shaft length 2000 mm

Part numbers Torque-resistant Linear Bushings without Shaft: R0696 0.. 00

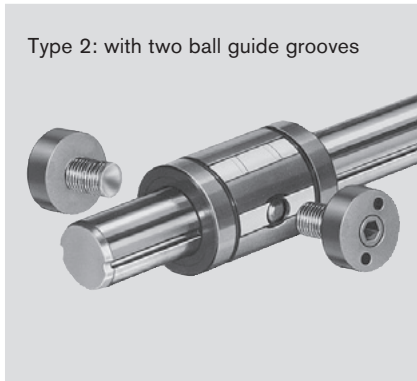

Shaft Ø d [mm]	Part numbers torque-resistant-Linear Bushings with shaft		
	Standard length per table	Shaft to specified length ¹⁾	Customized shaft
20	R0696 320 80	R0696 320 89	R0696 320 86
25	R0696 325 80	R0696 325 89	R0696 325 86
30	R0696 330 80	R0696 330 89	R0696 330 86
40	R0696 340 80	R0696 340 89	R0696 340 86
50	R0696 350 80	R0696 350 89	R0696 350 86

- 85 Shaft length 900 mm
- 87 Shaft length 1200 mm
- 88 Shaft length 2000 mm

Part numbers torque-resistant Linear Bushings without Shaft: R0696 3.. 00

¹⁾ Also available with tubular shaft from: Ø 25 R0696 ... 69 or
with corrosion-resistant steel shaft to ISO 683-17 / EN 10088: R0696 ... 79.

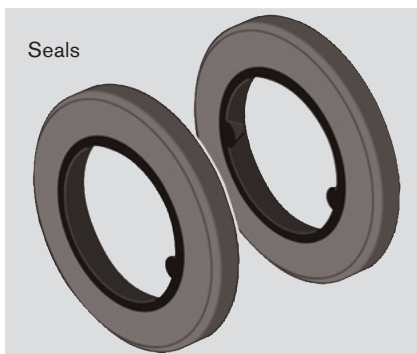

Shaft Ø d [mm]	Part numbers Seals	
	Type 1	Type 2
12	R1331 112 00	-
16	R1331 116 00	-
20	R1331 120 00	R1331 320 00
25	R1331 125 00	R1331 325 00
30	R1331 130 00	R1331 330 00
40	R1331 140 00	R1331 340 00
50	R1331 150 00	R1331 350 00

Seals must be ordered separately.

Dimensions

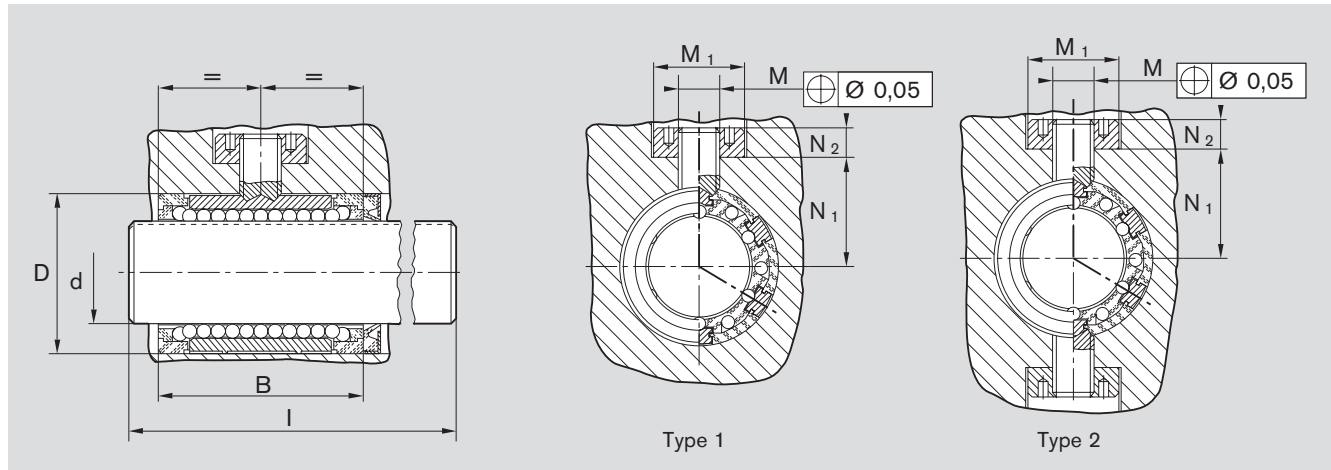

Ø d	Dimensions [mm]							Standard length [mm] l	Torque M _t [Nm]		Load Capacities ²⁾ [N]		Mass	
	Type 1	Type 2	D ¹⁾	B	M	M ₁ +0.1	N ₁		N ₂	Type 1	Type 2	dyn. C	stat. C ₀	Linear Bushings [kg]
12	-	22	32	M6x0.5	14	15.5	5	400	2	-	640	420	0.026	0.89
16	-	26	36	M6x0.5	14	19.5	5	400	3.3	-	780	530	0.032	1.57
20	20	32	45	M10x1	22	21.5	8	500	7.5	12	1550	1050	0.064	2.45
25	25	40	58	M10x1	22	28.5	8	500	15	24	3030	2180	0.135	3.80
30	30	47	68	M12x1	26	32	9.5	600	23	37	3680	2790	0.210	5.50
40	40	62	80	M12x1	26	44	9.5	600	53	86	6320	4350	0.390	9.80
50	50	75	100	M16x1.5	34	52	12.5	600	103	167	9250	6470	0.680	15.30

¹⁾ Recommended mounting bore: D^{IS7}

²⁾ The load capacities stated are minimum values as the position and direction of load cannot always be precisely defined.

The figures for dynamic load-carrying capacity have been calculated assuming a nominal travel of 100,000 m. For a nominal travel of 50,000 m, the "C" figures in the table must be multiplied by a factor of 1.26.

Seal

Structural design

- With metal case
- Elastomer seal

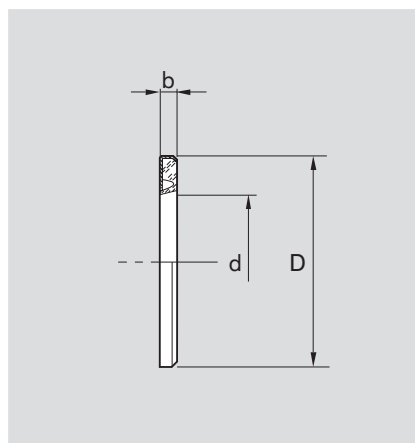

Ø d	Dimensions [mm]	
	D ³⁾	b +0.3
12	22	3
16	26	3
20	32	4
25	40	4
30	47	5
40	62	5
50	75	6

³⁾ The outer diameter D is about 0.1 mm oversized.
No retaining elements are required.

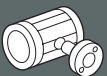

Torque-resistant Compact Linear Bushings

Torque-resistant Compact Linear Bushings, R0720

Structural design

- Plastic ball retainer and outer sleeve
- Hardened steel load bearing plates
- Balls made of anti-friction bearing steel
- Precision Steel Shaft with ball guide groove
- Hardened steel adjusting screw
- Steel lock screw

One ball guide groove for shaft diameter $d = 12$ and 16 mm

Two ball guide grooves for shaft diameter $d = 20$ mm and over

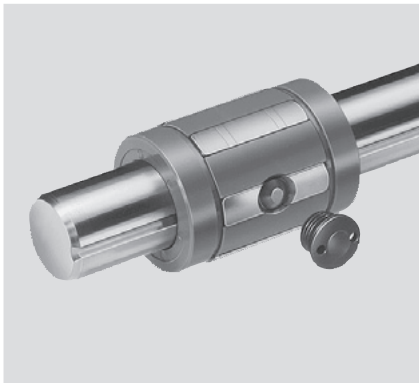

Shaft Ø d [mm]	Part numbers torque-resistant Compact Linear Bushings with shaft		
	Standard length per table	Shaft to specified length ¹⁾	Customized shaft
12	R0720 012 80	R0720 012 89	R0720 012 86
16	R0720 016 80	R0720 016 89	R0720 016 86
20	R0720 320 80	R0720 320 89	R0720 320 86
25	R0720 325 80	R0720 325 89	R0720 325 86
30	R0720 330 80	R0720 330 89	R0720 330 86
40	R0720 340 80	R0720 340 89	R0720 340 86
50	R0720 350 80	R0720 350 89	R0720 350 86

- 85 Shaft length 900 mm
- 87 Shaft length 1200 mm
- 88 Shaft length 2000 mm

Part numbers torque-resistant Compact Linear Bushings without shaft:

Sizes Ø 12 and 16: R0720 0.. 00

Sizes Ø 20 to 50: R0720 3.. 00

¹⁾ Also available with tubular shaft from: Ø 25 R0720 ... 69 or
with corrosion-resistant steel shaft to ISO 683-17 / EN 10088: R0720 ... 79.



Shaft Ø d [mm]	Part numbers Seale
12	R1331 112 00
16	R1331 116 00
20	R1331 320 00
25	R1331 325 00
30	R1331 330 00
40	R1331 340 00
50	R1331 350 00

Seals must be ordered seperately.

Dimensions

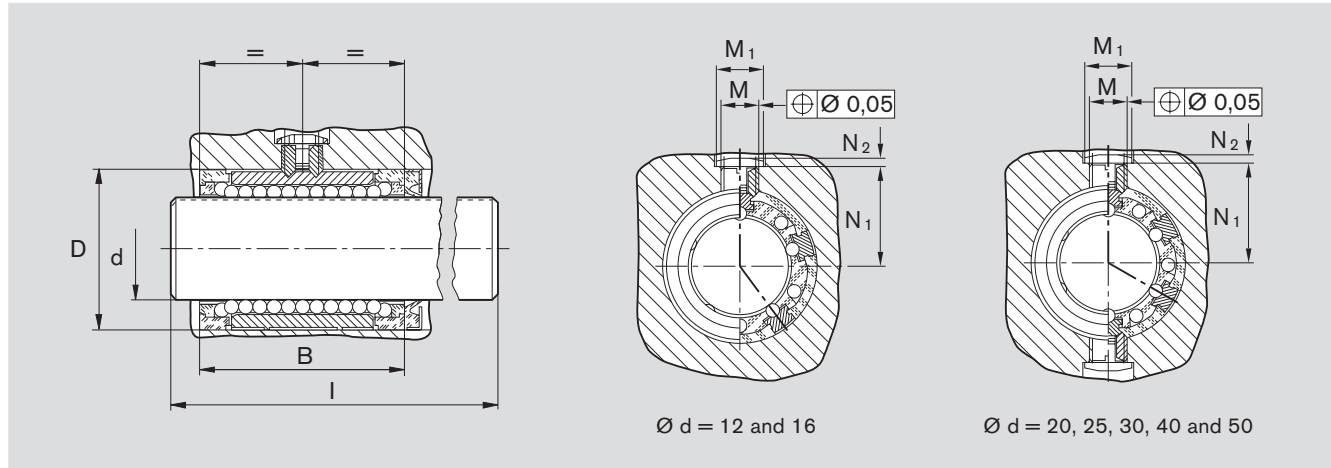

Ø d	D ¹⁾	Dimensions [mm]					Standard length [mm] l	Torque M _t [Nm]	Load Capacities ²⁾ [N]		Mass	
		B	M	M ₁	N ₁ +0.1	N ₂			dyn. C	stat. C ₀	Linear Bushings [kg]	Shaft [kg/m]
12	22	32	M6x0.5	8	14.4	1.3	400	2	640	420	0.026	0.89
16	26	36	M6x0.5	8	16.4	1.3	400	3.3	780	530	0.032	1.57
20	32	45	M10x1	12.5	21.8	1.9	500	12	1550	1050	0.071	2.45
25	40	58	M10x1	12.5	25.8	1.9	500	24	3030	2180	0.130	3.80
30	47	68	M12x1	15	29.7	2.5	600	37	3680	2790	0.200	5.50
40	62	80	M12x1	15	37.2	2.5	600	86	6320	4350	0.380	9.80
50	75	100	M16x1.5	20	46.7	3	600	167	9250	6470	0.620	15.30

¹⁾ Recommended mounting bore: D^{K6}

²⁾ The load capacities stated are minimum values as the position and direction of load cannot always be precisely defined.

The figures for dynamic load-carrying capacity have been calculated assuming a nominal travel of 100,000 m. For a nominal travel of 50,000 m, the 'C' figures in the table must be multiplied by a factor of 1.26.

Seal

- Structural design
- With metal case
 - Elastomer seal

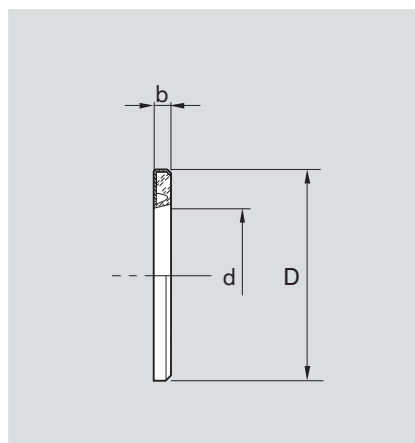

Ø d	Dimensions [mm]	
	D ³⁾	b +0,3
12	22	3
16	26	3
20	32	4
25	40	4
30	47	5
40	62	5
50	75	6

³⁾ The outer diameter D is about 0.1 mm oversized. No retaining elements required.

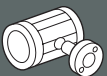

Linear sets with Torque-resistant Linear Bushings

Overview/Mounting instructions

Linear sets with torque-resistant Linear Bushings, aluminum housing

Type 1: one ball guide groove

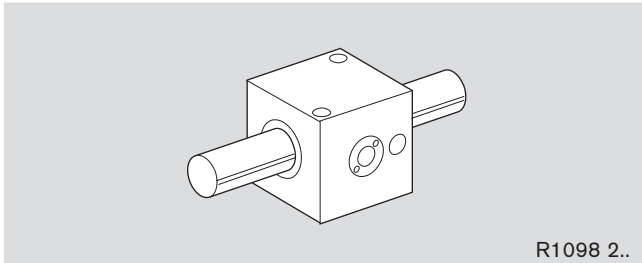

Type 2: two ball guide grooves

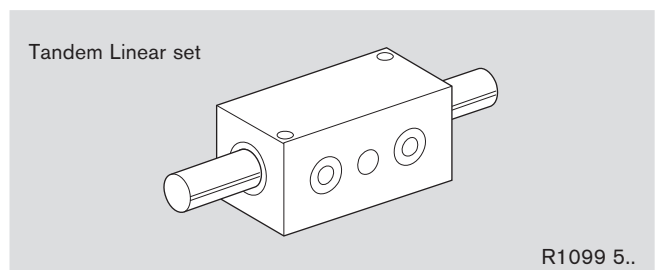
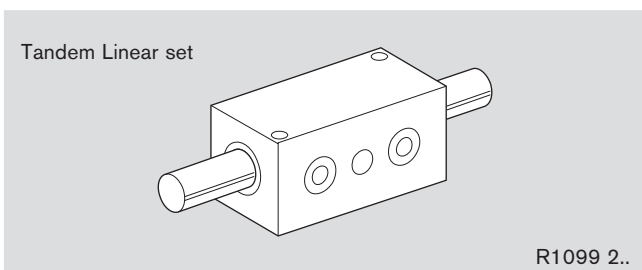
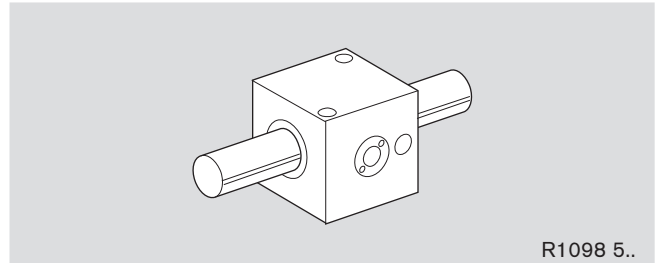

Linear sets with torque-resistant Linear Bushings, steel housing

Type 1: one ball guide groove

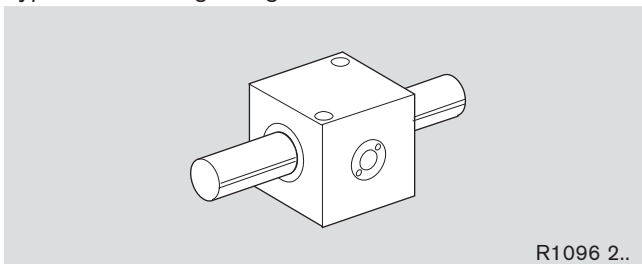

Type 2: two ball guide grooves

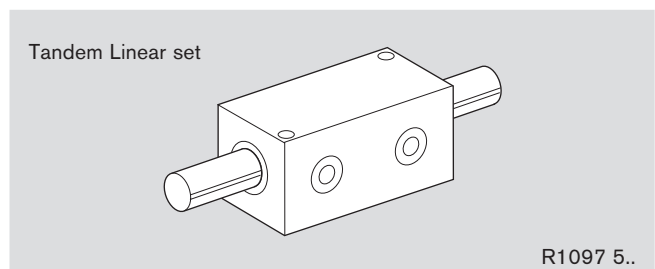
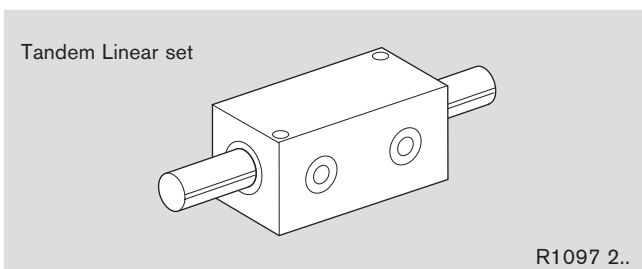
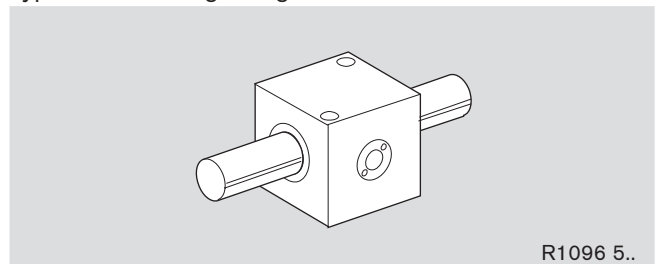

Mounting instructions



Linear sets are ready mounted and adjusted to zero-clearance. If the shaft has been removed, it is necessary to loosen the adjusting screws and re-adjust the torque-resistant Linear Bushing.

Linear sets with torque-resistant Compact Linear Bushings, sleeve design

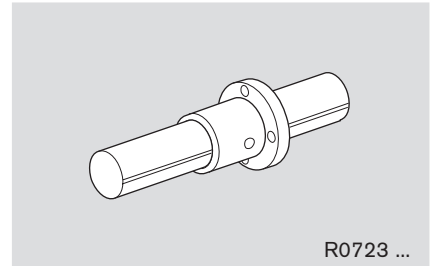
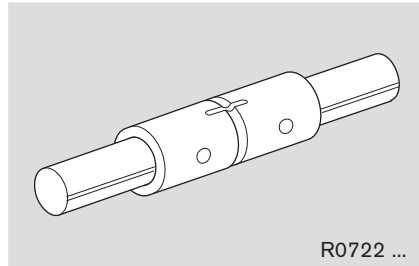
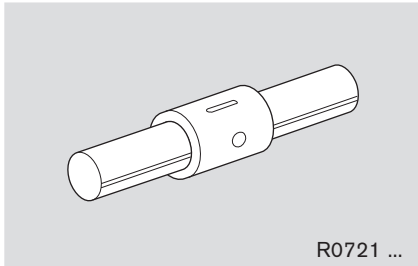

Mounting instructions



Linear sets (sleeve design) are ready mounted and adjusted to zero-clearance. If the shaft has been removed, it is necessary to loosen the adjusting screws and re-adjust the torque-resistant Linear Bushing.

Torque-resistant Linear Bushings with four ball guide grooves

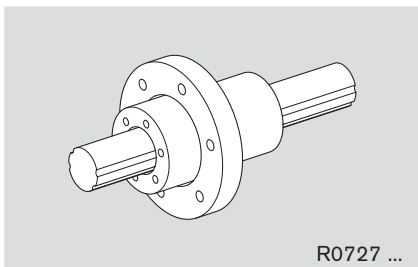
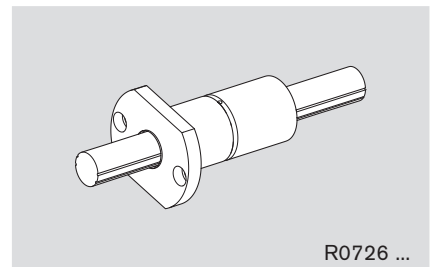
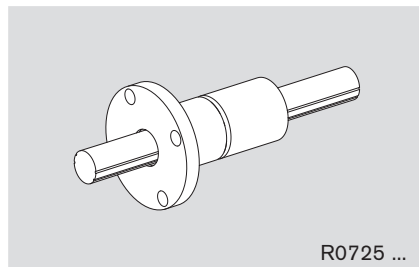
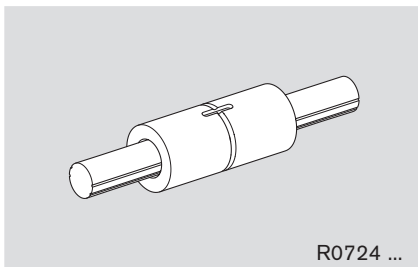

Mounting instructions



With torque-resistant Linear Bushings with four ball guide grooves, the Linear Bushings and Shaft are delivered separately. When inserting the Shaft ensure that the grooves align and do not tilt!

Linear sets with Torque-resistant Linear Bushings, Aluminum Housing

Linear sets, R1098 2..

Type 1: one ball guide groove

Linear sets, R1098 5..

Type 2: two ball guide grooves

Structural design

- Precision Housing, lightweight series, (aluminum)
- Torque-Resistant Linear Bushing
- Precision Steel Shaft with ball guide groove
- Torque-transmitting steel load bearing plates adjusted to zero clearance before leaving the factory
- External seals
- Stability against cocking loads: see Linear Sets, Tandem version
- 1 or 2 ball guide grooves
- Easy re-lubrication



Type 1: one ball guide grooves

Shaft Ø d [mm]	Part numbers Linear set with shaft		
	Standard length per table	Shaft to specified length ¹⁾	Customized shaft
12	R1098 212 80	R1098 212 89	R1098 212 86
16	R1098 216 80	R1098 216 89	R1098 216 86
20	R1098 220 80	R1098 220 89	R1098 220 86
25	R1098 225 80	R1098 225 89	R1098 225 86
30	R1098 230 80	R1098 230 89	R1098 230 86
40	R1098 240 80	R1098 240 89	R1098 240 86
50	R1098 250 80	R1098 250 89	R1098 250 86

- 85 Shaft length 900 mm
- 87 Shaft length 1200 mm
- 88 Shaft length 2000 mm

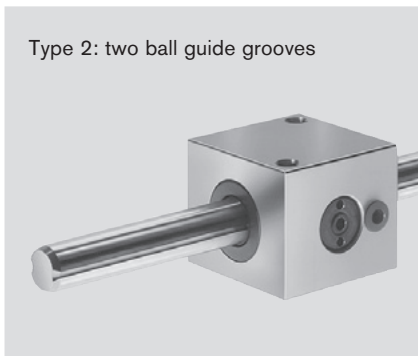

Type 2: two ball guide grooves

Shaft Ø d [mm]	Part numbers Linear set with shaft		
	Standard length per table	Shaft to specified length ¹⁾	Customized shaft
20	R1098 520 80	R1098 520 89	R1098 520 86
25	R1098 525 80	R1098 525 89	R1098 525 86
30	R1098 530 80	R1098 530 89	R1098 530 86
40	R1098 540 80	R1098 540 89	R1098 540 86
50	R1098 550 80	R1098 550 89	R1098 550 86

- 85 Shaft length 900 mm
- 87 Shaft length 1200 mm
- 88 Shaft length 2000 mm

¹⁾ Also available with tubular shaft: from Ø 25 R1098-...-69 or with corrosion-resistant steel shaft to DIN 17230 / EN 10088: R1098-...-79.

Dimensions

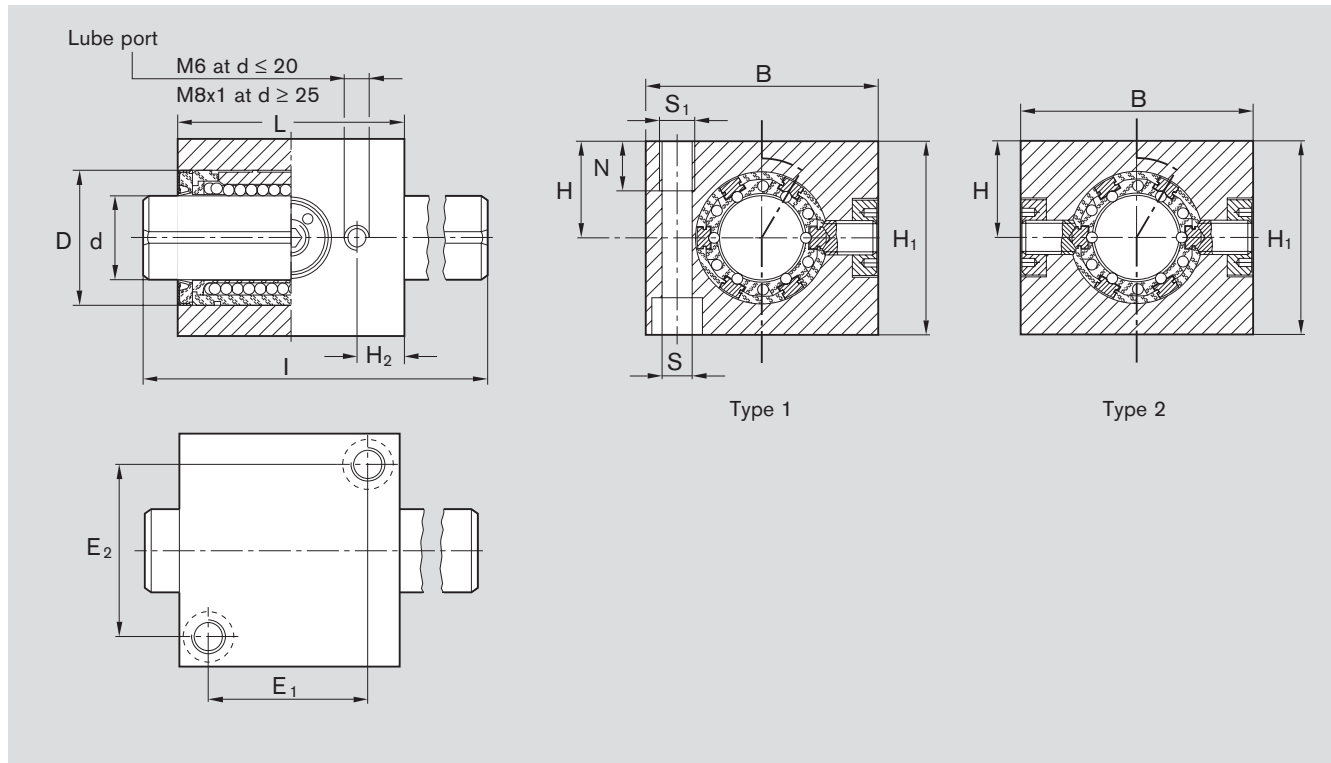

$\varnothing d$	Dimensions [mm]												Standard length [mm]	Torque M_t [Nm]		Load Capacities ³⁾ [N]		Mass	
	Type 1	Type 2	B	H_1	$H_1^{1)}$	H_2	L	D	E_1	E_2	$S^{2)}$	S_1		N	Type 1	Type 2	dyn. C	stat. C_0	Linear set [kg]
12	-	42	35	18	8.5	40	22	28	30	5.3	M6	12	400	2	-	640	420	0.15	0.89
16	-	50	42	22	10	44	26	30	36	5.3	M6	12	400	3.3	-	780	530	0.22	1.57
20	20	60	50	25	11	55	32	39	44	6.6	M8	12	500	7.5	12	1550	1050	0.42	2.45
25	25	74	60	30	15.5	68	40	48	54	8.4	M10	15	500	15	24	3030	2180	0.7	3.80
30	30	84	70	35	16.5	80	47	58	62	10.5	M12	18	600	23	37	3680	2790	1.1	5.50
40	40	108	90	45	18.5	92	62	64	80	13.5	M16	20	600	53	86	6320	4350	2.1	9.80
50	50	130	105	50	22.5	114	75	84	100	13.5	M16	20	600	103	167	9250	6470	3.5	15.30

¹⁾ If two or more Linear sets are mounted on the same shaft, they are leveled to the same dimension H by grinding after mounting. Dimension H is then 0.5 mm smaller.

²⁾ Mounting screws to ISO 4762-8.8.

³⁾ The load capacities stated are minimum values as the position and direction of load cannot always be precisely defined.

The figures for dynamic load-carrying capacity have been calculated assuming a nominal travel of 100,000 m. For a nominal travel of 50,000 m, the 'C' figures in the table must be multiplied by a factor of 1.26.

Lubricating instructions: Lubricate only when shaft inserted, add lubricant through lube port until excess emerges.

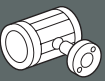

Linear sets with torque-resistant Linear Bushings, aluminum housing

Tandem

Linear sets, R1099 2..

Type 1: one ball guide groove

Linear-Sets, R1099 5..

Type 2: two ball guide grooves

Structural design

- Precision Tandem Housing, lightweight series, (aluminum)
- Two torque-resistant Linear Bushings
- Precision Steel Shaft with ball guide groove
- Torque transmitting steel load bearing plates adjusted to zero clearance before leaving the factory
- External seals
- Stability against cocking loads
- 1 or 2 ball guide grooves
- Easy re-lubrication

Type 1: one ball guide groove

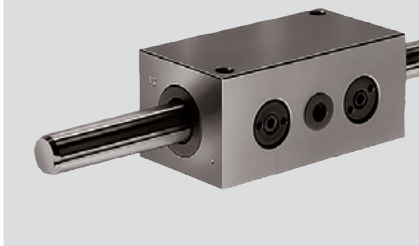

Shaft Ø d [mm]	Part numbers Linear set with shaft		
	Standard length per table	Shaft to specified length ¹⁾	Customized shaft
12	R1099 212 80	R1099 212 89	R1099 212 86
16	R1099 216 80	R1099 216 89	R1099 216 86
20	R1099 220 80	R1099 220 89	R1099 220 86
25	R1099 225 80	R1099 225 89	R1099 225 86
30	R1099 230 80	R1099 230 89	R1099 230 86
40	R1099 240 80	R1099 240 89	R1099 240 86
50	R1099 250 80	R1099 250 89	R1099 250 86

- 85 Shaft length 900 mm
- 87 Shaft length 1200 mm
- 88 Shaft length 2000 mm

Type 2: two ball guide grooves

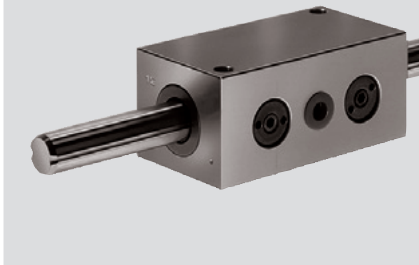

Shaft Ø d [mm]	Part numbers Linear set with shaft		
	Standard length per table	Shaft to specified length ¹⁾	Customized shaft
20	R1099 520 80	R1099 520 89	R1099 520 86
25	R1099 525 80	R1099 525 89	R1099 525 86
30	R1099 530 80	R1099 530 89	R1099 530 86
40	R1099 540 80	R1099 540 89	R1099 540 86
50	R1099 550 80	R1099 550 89	R1099 550 86

- 85 Shaft length 900 mm
- 87 Shaft length 1200 mm
- 88 Shaft length 2000 mm

¹⁾ Also available with tubular shaft to Ø25 R1099-...-69 or with corrosion-resistant steel shaft to DIN 17230 / EN 10088: R1099-...-79.

Dimensions

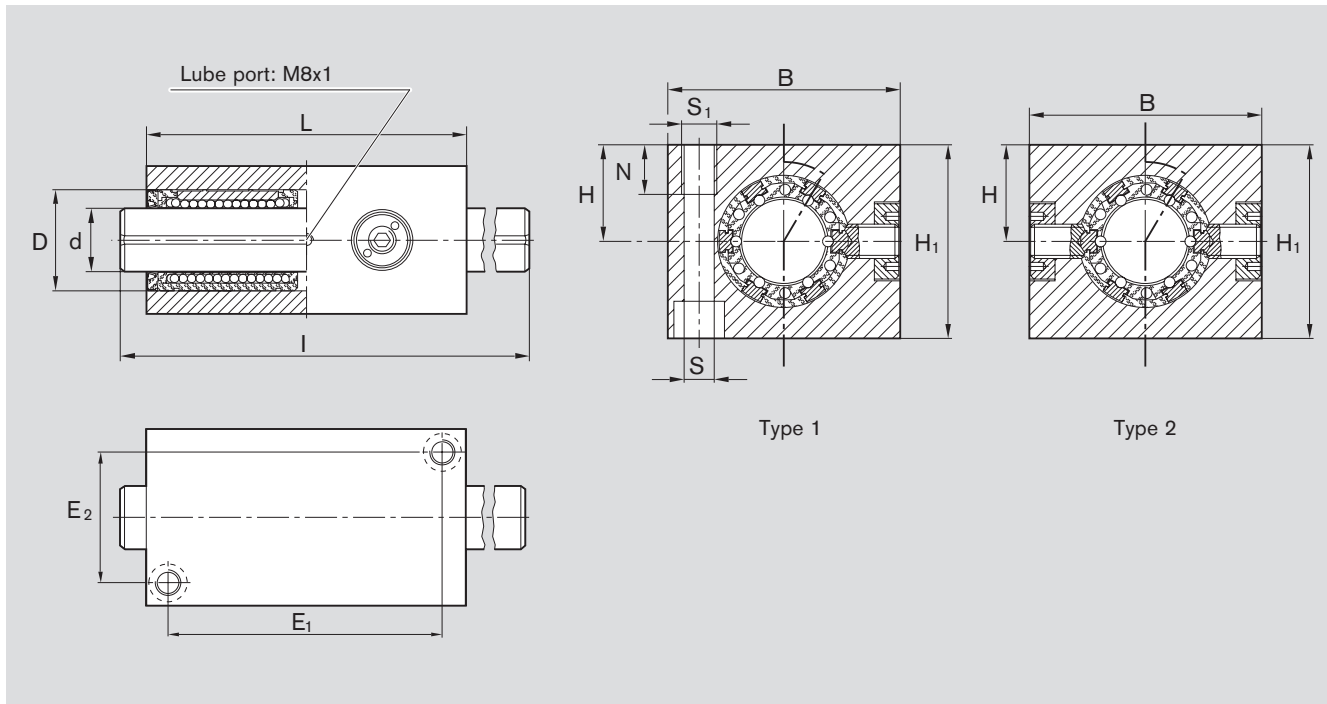

Ø d	Dimensions [mm]											Standard length [mm]	Torque M _t [Nm]		Load Capacities ³⁾ [N]		Mass	
	Type 1	Type 2	B	H ₁	H ¹⁾ +0.013 -0.022	L	D	E ₁	E ₂	S ²⁾	S ₁		N	Type 1	Type 2	dyn. C	stat. C ₀	Linear set [kg]
12	-	42	35	18	76	22	64	30	5.3	M6	12	400	3.2	-	1040	840	0.29	0.89
16	-	50	42	22	84	26	70	36	5.3	M6	12	400	5.5	-	1260	1060	0.43	1.57
20	20	60	50	25	104	32	88	44	6.6	M8	12	500	12	20	2500	2100	0.8	2.45
25	25	74	60	30	130	40	110	54	8.4	M10	15	500	24	40	4900	4360	1.5	3.80
30	30	84	70	35	152	47	130	62	10.5	M12	18	600	37	60	6000	5580	2.2	5.50
40	40	108	90	45	176	62	148	80	13.5	M16	20	600	86	140	10200	8700	4.0	9.80
50	50	130	105	50	224	75	194	100	13.5	M16	20	600	167	272	15000	12940	6.9	15.30

¹⁾ If two or more Linear sets are mounted on the same shaft, they are leveled to the same dimension H by grinding after mounting. Dimension H is then 0.5 mm smaller.

²⁾ Mounting screws to ISO 4762-8.8.

³⁾ Load capacity, when both linear bushings are subject to equal loading.

The load capacities stated are minimum values as the position and direction of load cannot always be precisely defined.

The figures for dynamic load-carrying capacity have been calculated assuming a nominal travel of 100,000 m. For a nominal travel of 50,000 m, the 'C' figures in the table must be multiplied by a factor of 1.26.

Lubricating instructions: Lubricate only when the shaft is inserted, add lubricant through lube port until excess emerges.

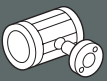

Linear sets with torque-resistant Linear Bushings, steel housing

Linear sets, R1096 2..

Type 1: one ball guide groove

Linear sets, R1096 5..

Type 2: two ball guide grooves

Structural design

- Precision housing (steel)
- Torque-resistant Linear Bushings
- Precision Steel Shaft with ball guide groove
- Torque-transmitting steel load bearing plates adjusted to zero-clearance before leaving the factory
- External seals
- Stability against cocking loads: see Linear sets, Tandem version
- 1 or 2 ball guide grooves



Type 1: one ball guide groove

Shaft Ø d [mm]	Part numbers Linear set with shaft		
	Standard length per table	Shaft to specified length ¹⁾	Customized shaft
12	R1096 212 80	R1096 212 89	R1096 212 86
16	R1096 216 80	R1096 216 89	R1096 216 86
20	R1096 220 80	R1096 220 89	R1096 220 86
25	R1096 225 80	R1096 225 89	R1096 225 86
30	R1096 230 80	R1096 230 89	R1096 230 86
40	R1096 240 80	R1096 240 89	R1096 240 86
50	R1096 250 80	R1096 250 89	R1096 250 86

- 85 Shaft length 900 mm
- 87 Shaft length 1200 mm
- 88 Shaft length 2000 mm



Type 2: two ball guide grooves

Shaft Ø d [mm]	Part numbers Linear set with shaft		
	Standard length per table	Shaft to specified length ¹⁾	Customized shaft
20	R1096 520 80	R1096 520 89	R1096 520 86
25	R1096 525 80	R1096 525 89	R1096 525 86
30	R1096 530 80	R1096 530 89	R1096 530 86
40	R1096 540 80	R1096 540 89	R1096 540 86
50	R1096 550 80	R1096 550 89	R1096 550 86

- 85 Shaft length 900 mm
- 87 Shaft length 1200 mm
- 88 Shaft length 2000 mm

¹⁾ Also available with tubular shaft to Ø25 R1096-...-69 or with corrosion-resistant steel shaft to DIN 17230 / EN 10088: R1096-...-79.

Dimensions

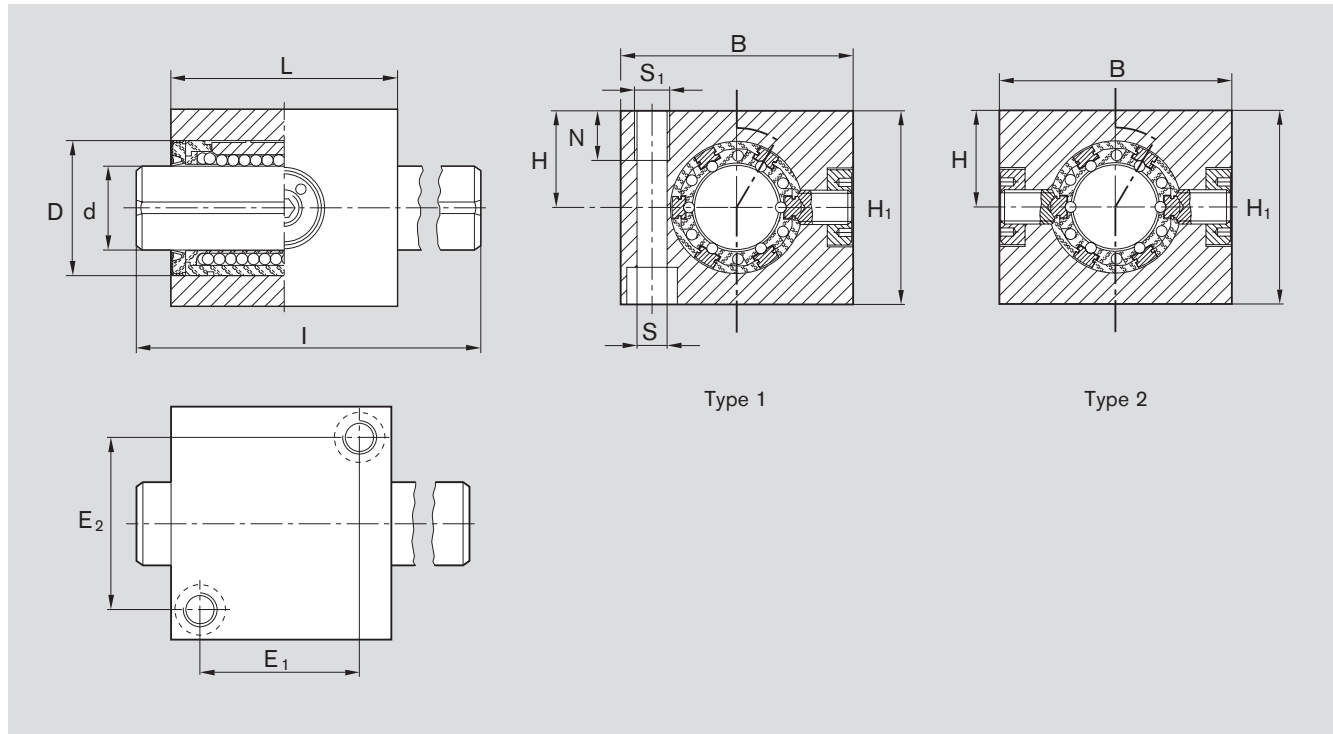

Ø d		Dimensions [mm]										Standard length [mm] l	Torque M _t [Nm]		Load Capacities ³⁾ [N]		Mass	
Type 1	Type 2	B	H ₁	H ¹⁾ +0.013 -0.022	L	D	E ₁	E ₂	S ²⁾	S ₁	N		Type 1	Type 2	dyn. C	stat. C ₀	Linear set [kg]	Shaft [kg/m]
12	-	42	35	18	40	22	28	30	5.3	M6	12	400	2	-	640	420	0.35	0.89
16	-	50	42	22	44	26	30	36	5.3	M6	12	400	3.3	-	780	530	0.55	1.57
20	20	60	50	25	55	32	39	44	6.6	M8	12	500	7.5	12	1550	1050	1.0	2.45
25	25	74	60	30	68	40	48	54	8.4	M10	15	500	15	24	3030	2180	1.5	3.80
30	30	84	70	35	80	47	58	62	10.5	M12	18	600	23	37	3680	2790	2.7	5.50
40	40	108	90	45	92	62	64	80	13.5	M16	20	600	53	86	6320	4350	5.0	9.80
50	50	130	105	50	114	75	84	100	13.5	M16	20	600	103	167	9250	6470	8.7	15.30

¹⁾ If two or more Linear sets are mounted on the same shaft, they are leveled to the same dimension H by grinding after mounting. Dimension H is then 0.5 mm smaller.

²⁾ Mounting screws to ISO 4762-8.8.

³⁾ The load capacities are minimum values as the position and direction of load cannot always be precisely defined.

The figures for dynamic load-carrying capacity have been calculated assuming a nominal travel of 100,000 m. For a nominal travel of 50,000 m, the 'C' figures in the table must be multiplied by a factor of 1.26.



Linear sets with torque-resistant Linear Bushings, steel housing

Tandem

Linear sets, R1097 2..

Type 1: one ball guide groove

Linear sets, R1097 5..

Type 2: two ball guide grooves

Structural design

- Precision housing (steel)
- Two torque-resistant Linear Bushings
- Precision steel Shaft with ball guide groove
- Torque transmitting steel load bearing plates adjusted to zero-clearance before leaving the factory
- External seals
- Stability against cocking loads
- 1 or 2 ball guide grooves

Type 1: one ball guide groove



Shaft Ø d [mm]	Standard length per table	Part numbers Linear set with shaft	
		Shaft to specified length ¹⁾	Customized shaft
12	R1097 212 80	R1097 212 89	R1097 212 86
16	R1097 216 80	R1097 216 89	R1097 216 86
20	R1097 220 80	R1097 220 89	R1097 220 86
25	R1097 225 80	R1097 225 89	R1097 225 86
30	R1097 230 80	R1097 230 89	R1097 230 86
40	R1097 240 80	R1097 240 89	R1097 240 86
50	R1097 250 80	R1097 250 89	R1097 250 86

85 Shaft length 900 mm

87 Shaft length 1200 mm

88 Shaft length 2000 mm

Type 2: two ball guide grooves

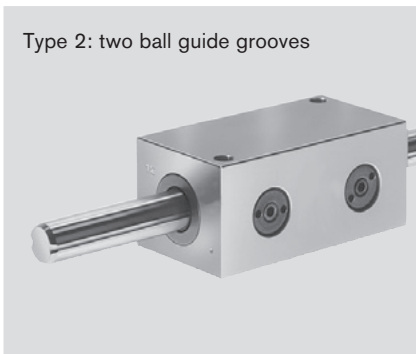

Shaft Ø d [mm]	Standard length per table	Part numbers Linear set with shaft	
		Shaft to specified length ¹⁾	Customized shaft
20	R1097 520 80	R1097 520 89	R1097 520 86
25	R1097 525 80	R1097 525 89	R1097 525 86
30	R1097 530 80	R1097 530 89	R1097 530 86
40	R1097 540 80	R1097 540 89	R1097 540 86
50	R1097 550 80	R1097 550 89	R1097 550 86

85 Shaft length 900 mm

87 Shaft length 1200 mm

88 Shaft length 2000 mm

¹⁾ Also available with tubular shaft to Ø25 R1097-...-69 or
with corrosion-resistant steel shaft to DIN 17230 / EN 10088: R1099-...-79.

Dimensions

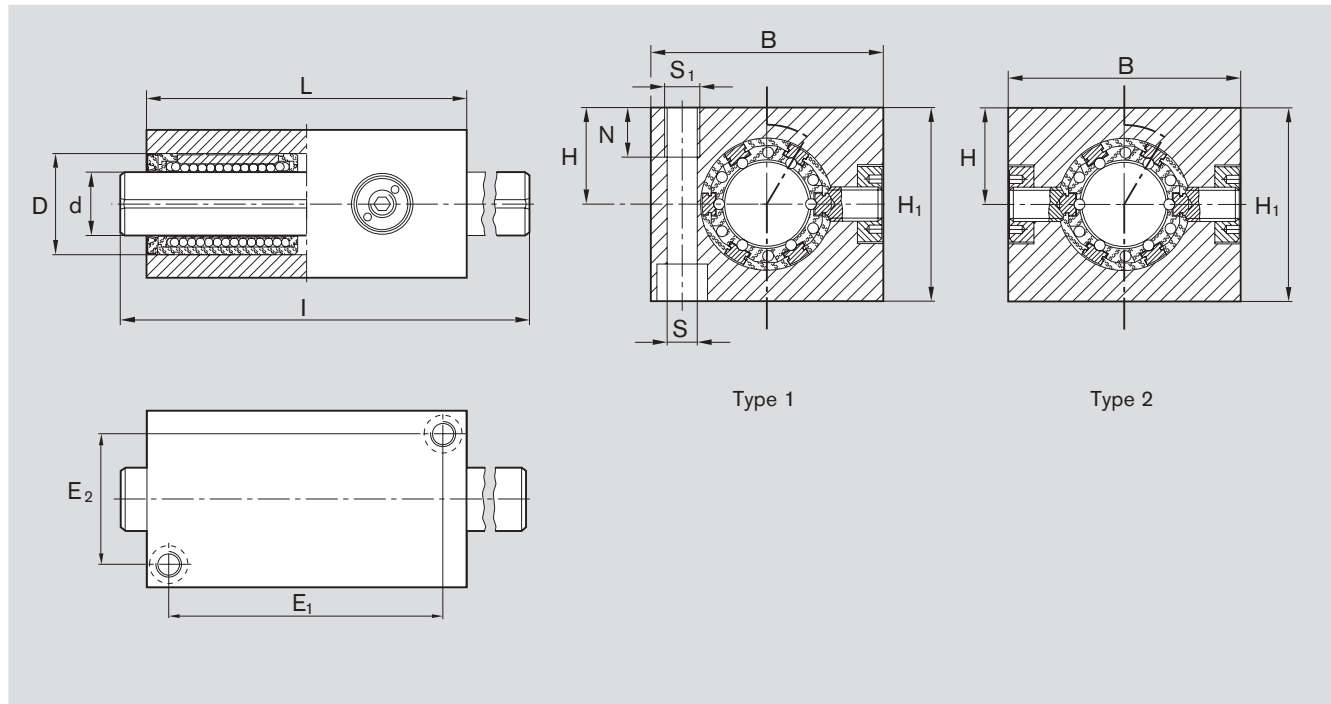

Ø d	Dimensions [mm]											Standard length [mm] l	Torque M _l [Nm]		Load Capacities ³⁾ [N]		Mass	
	Type 1	Type 2	B	H ₁	H ¹⁾ +0.013 -0.022	L	D	E ₁	E ₂	S ²⁾	S ₁		N	Type 1	Type 2	dyn. C	stat. C ₀	Linear set [kg]
12	-	42	35	18	76	22	64	30	5.3	M6	12	400	3.2	-	1040	840	0.7	0.89
16	-	50	42	22	84	26	70	36	5.3	M6	12	400	5.5	-	1260	1060	1.0	1.57
20	20	60	50	25	104	32	88	44	6.6	M8	12	500	12	20	2500	2100	1.9	2.45
25	25	74	60	30	130	40	110	54	8.4	M10	15	500	24	40	4900	4360	3.5	3.80
30	30	84	70	35	152	47	130	62	10.5	M12	18	600	37	60	6000	5580	5.2	5.50
40	40	108	90	45	176	62	148	80	13.5	M16	20	600	86	140	10200	8700	9.8	9.80
50	50	130	105	50	224	75	194	100	13.5	M16	20	600	167	272	15000	12940	17.0	15.30

¹⁾ If two or more Linear sets are mounted on the same shaft, they are leveled to the same dimension H by grinding after mounting. Dimension H is then 0.5 mm smaller.

²⁾ Mounting screws to ISO 4762-8.8.

³⁾ The load capacities are minimum values as the position and direction of load cannot always be precisely defined.

The figures for dynamic load-carrying capacity have been calculated assuming a nominal travel of 100,000 m. For a nominal travel of 50,000 m, the 'C' figures in the table must be multiplied by a factor of 1.26.



Linear sets with torque-resistant Compact Linear Bushings

Mounting instructions

- Recommendations for mounting, arrangement of lubrication channels and bores as well as retention
- Recommended mounting bore: D^{H6} (D^{J6})

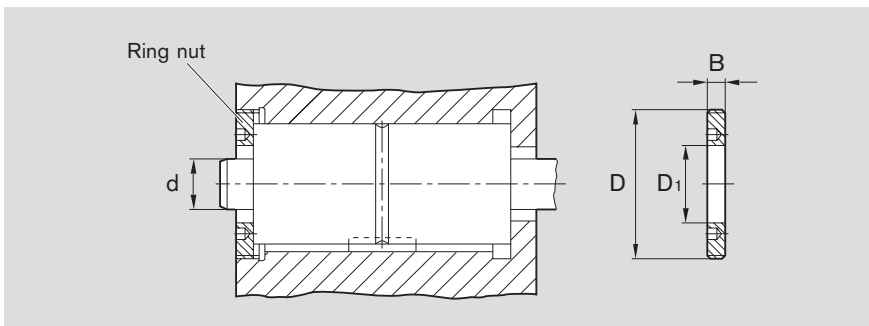
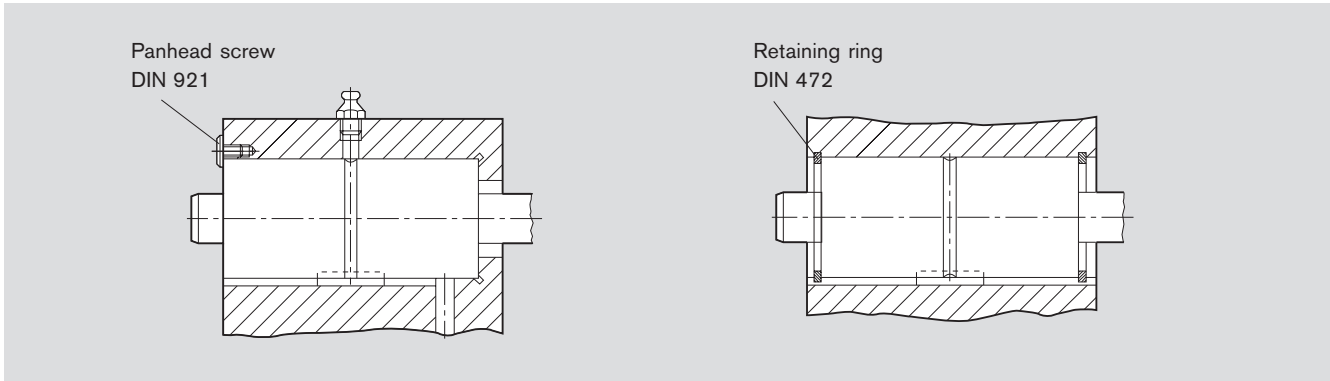

Shaft Ø d [mm]	Ring nut		
	Part numbers	Dimensions [mm]	
		D	D ₁ B
12	R1507 1 4003	M40x1,5	22 8
16	R1507 2 4004	M45x1,5	28 8
20	R1507 3 4005	M55x1,5	34 10
25	R1507 4 4006	M70x1,5	42 12
30	R1507 5 4007	M78x2	52 15
40	R1507 6 4009	M92x2	65 16
50	R1507 7 4011	M112x2	82 18

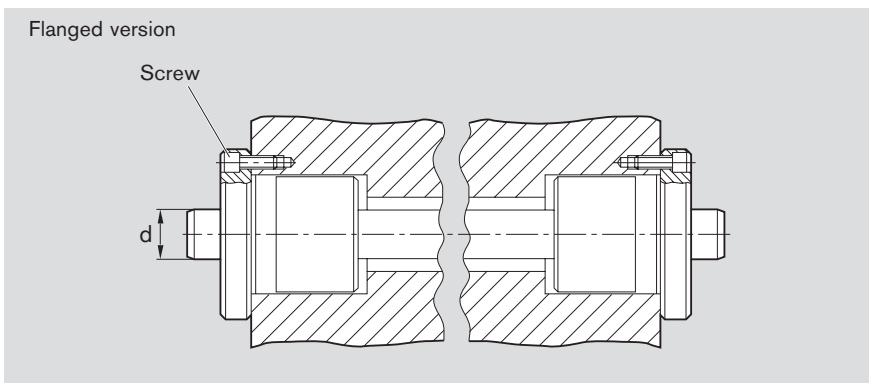

Shaft Ø d [mm]	Screw
	ISO 4762-8.8
12	M4x16
16	M4x16
20	M5x16
25	M6x20
30	M8x25
40	M8x25
50	M10x30

Lubrication

- Lubrication for version with one Torque-Resistant Compact Linear Bushing
 - Lubricate only when shaft inserted. Add lubricant through lube port diam. 3.9 until excess emerges.
- Lubrication for Tandem version
 - Lubricate only when shaft inserted. Add lubricant through the centrally located lube groove on the outer diameter until excess emerges.
- Lubrication for Flanged version
 - Lubricate only when shaft inserted. Add lubricant through the recessed funnel-shaped lube port on the end face until excess emerges.

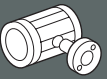

Linear sets with torque-resistant Compact Linear Bushings

Linear sets, R0721

Structural design

- Space-saving steel sleeve
- Torque-resistant Compact Linear Bushing
- Precision Steel Shaft with ball guide groove
- Easy re-lubrication
- Torque transmitting steel load bearing plates adjusted to zero clearance before leaving factory
- External seals
- Stability against cocking loads: see Linear sets (sleeve design), Tandem version
- Keyway for torque transmission

one ball guide groove
for Shaft $\varnothing d = 12$ and 16 mm

two ball guide grooves
for Shafts $\varnothing d = 20$ mm

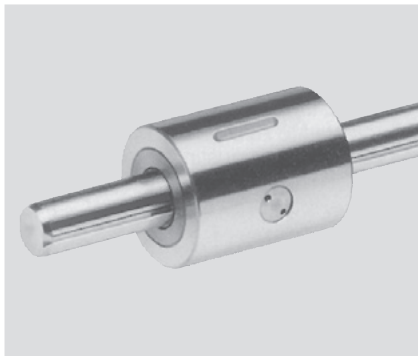

Shaft $\varnothing d$ [mm]	Part numbers Linear set with shaft		
	Standard length per table	Shaft to specified length ¹⁾	Customized shaft
12	R0721 212 80	R0721 212 89	R0721 212 86
16	R0721 216 80	R0721 216 89	R0721 216 86
20	R0721 520 80	R0721 520 89	R0721 520 86
25	R0721 525 80	R0721 525 89	R0721 525 86
30	R0721 530 80	R0721 530 89	R0721 530 86
40	R0721 540 80	R0721 540 89	R0721 540 86
50	R0721 550 80	R0721 550 89	R0721 550 86

- 85 Shaft length 900 mm
- 87 Shaft length 1200 mm
- 88 Shaft length 2000 mm

¹⁾ Also available with tubular shaft to $\varnothing 25$ R0721-...-69 or with corrosion-resistant steel shaft to DIN 17230 / EN 10088: R0721-...-79.

Dimensions

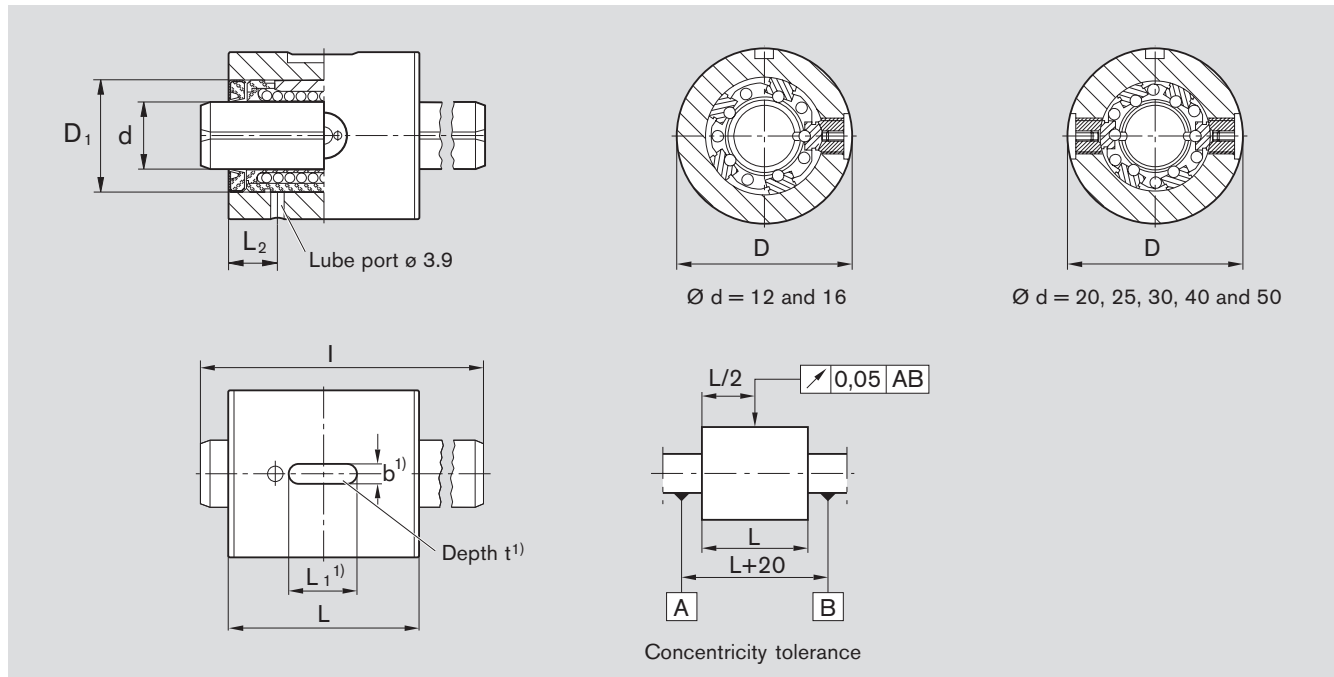

¹⁾ For Key A... DIN 6885.

Ø d	Dimensions [mm]							Standard length [mm] l	Torque M _t [Nm]	Load Capacities ²⁾ [N]		Mass	
	D h6	L h11	D ₁	L ₁	b P9	t	L ₂			dyn. C	stat. C ₀	Linear set [kg]	Shaft [kg/m]
12	32	40	22	14	5	3	11	400	2	640	420	0.16	0.89
16	36	44	26	16	5	3	12	400	3,3	780	530	0.20	1.57
20	48	55	32	20	5	3	14	500	12	1550	1050	0.50	2.45
25	56	68	40	25	6	3.5	15.5	500	24	3030	2180	0.80	3.80
30	65	80	47	28	6	3.5	16.5	600	37	3680	2790	1.20	5.50
40	80	92	62	32	8	4	18.5	600	86	6320	4350	1.80	9.80
50	100	114	75	40	8	4	22.5	600	167	9250	6470	3.70	15.30

²⁾ The load capacities are minimum values as the position and direction of load cannot always be precisely defined.

The figures for dynamic load-carrying capacity have been calculated assuming a nominal travel of 100,000 m. For a nominal travel of 50,000 m, the 'C' figures in the table must be multiplied by a factor of 1.26.



Linear sets with torque-resistant Compact Linear Bushings

Tandem

Linear sets, R0722

Structural design

- Space-saving steel sleeve
- Two torque-resistant Compact Linear Bushings
- Precision steel shaft with ball guide groove
- Easy re-lubrication
- Torque-transmitting steel load bearing plates adjusted to zero-clearance before leaving factory
- External seals
- Stability against cocking loads
- Keyway for torque transmission
- Easy re-lubrication

one ball guide groove
for Shaft $\varnothing d = 12$ and 16 mm

two ball guide grooves
for Shafts $\varnothing d = 20$ mm

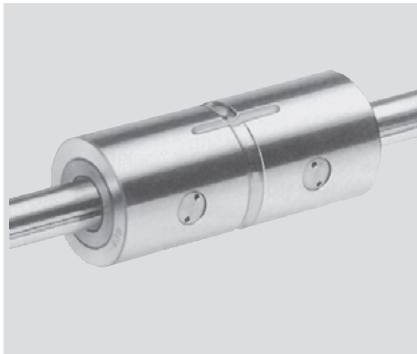

Shaft $\varnothing d$ [mm]	Part numbers Linear set with shaft		
	Standard length per table	Shaft to specified length ¹⁾	Customized shaft
12	R0722 212 80	R0722 212 89	R0722 212 86
16	R0722 216 80	R0722 216 89	R0722 216 86
20	R0722 520 80	R0722 520 89	R0722 520 86
25	R0722 525 80	R0722 525 89	R0722 525 86
30	R0722 530 80	R0722 530 89	R0722 530 86
40	R0722 540 80	R0722 540 89	R0722 540 86
50	R0722 550 80	R0722 550 89	R0722 550 86

- 85 Shaft length 900 mm
- 87 Shaft length 1200 mm
- 88 Shaft length 2000 mm

¹⁾ Also available with tubular shaft to $\varnothing 25$ R0722-...-69 or
with corrosion-resistant steel shaft to DIN 17230 / EN 10088: R0722-...-79.

Dimensions

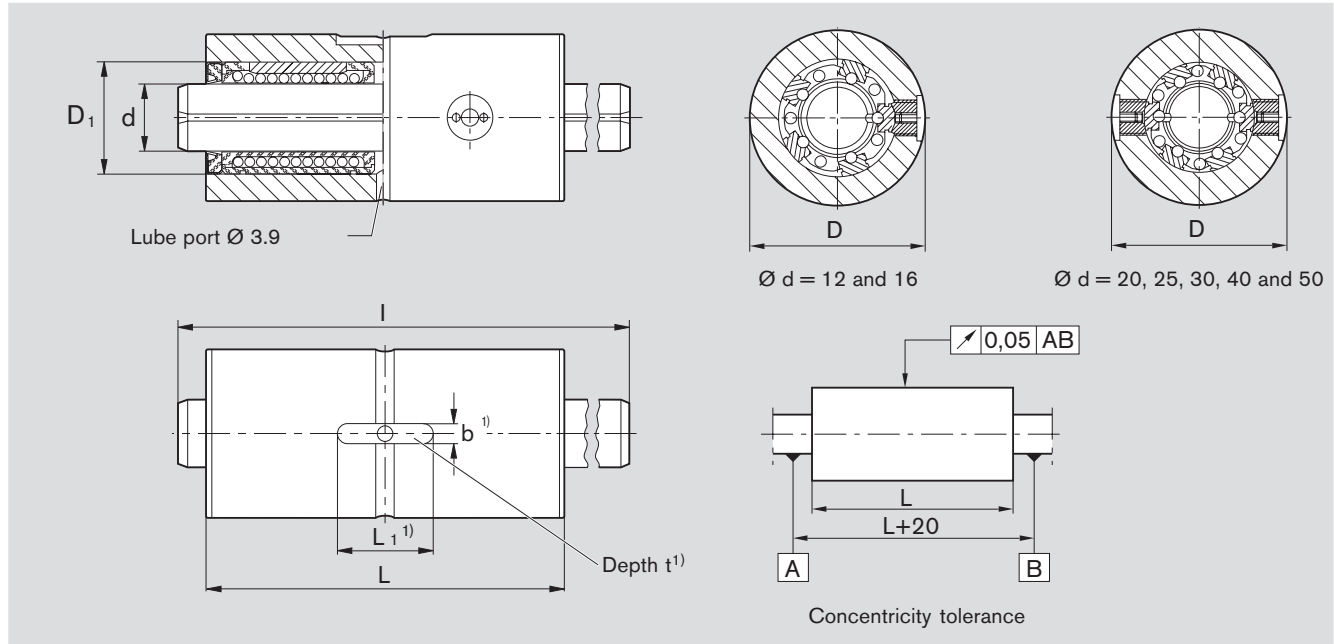

¹⁾ For key A... DIN 6885

Ø d	Dimensions [mm]						Standard length [mm] l	Torque M _t [Nm]	Load Capacities ²⁾ [N]		Mass	
	D h6	L h11	D ₁	L ₁	b P9	t			dyn. C	stat. C ₀	Linear set [kg]	Shaft [kg/m]
12	32	76	22	20	5	3	400	3.2	1040	840	0.32	0.89
16	36	84	26	22	5	3	400	5.5	1260	1060	0.40	1.57
20	48	104	32	28	5	3	500	20	2500	2100	0.95	2.45
25	56	130	40	36	6	3.5	500	40	4900	4360	1.50	3.80
30	65	152	47	40	6	3.5	600	60	6000	5580	2.30	5.50
40	80	176	62	45	8	4	600	140	10200	8700	3.50	9.80
50	100	224	75	63	8	4	600	272	15000	12940	7.30	15.30

²⁾ Load capacity, when both linear bushings are subject to equal loading.

The load capacities are minimum values as the position and direction of load cannot always be precisely defined.



Linear sets with torque-resistant Compact Linear Bushings

Flanged

Linear sets, R0723

Structural design

- Flanged steel sleeve
- Torque-resistant Compact Linear Bushing
- Precision steel shaft with ball guide groove
- Torque transmitting steel load bearing plates adjusted to zero-clearance before leaving factory
- External seals
- Stability against cocking loads installation of two linear sets (see also "Retention options - Linear Sets - sleeve design")
- Easy re-lubrication

one ball guide groove
for Shaft $\varnothing d = 12$ and 16 mm

two ball guide grooves
for Shafts $\varnothing d = 20$ mm

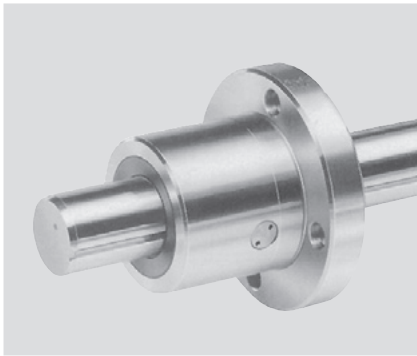

Shaft $\varnothing d$ [mm]	Part numbers Linear set with shaft		
	Standard length per table	Shaft to specified length ¹⁾	Customized shaft
12	R0723 212 80	R0723 212 89	R0723 212 86
16	R0723 216 80	R0723 216 89	R0723 216 86
20	R0723 520 80	R0723 520 89	R0723 520 86
25	R0723 525 80	R0723 525 89	R0723 525 86
30	R0723 530 80	R0723 530 89	R0723 530 86
40	R0723 540 80	R0723 540 89	R0723 540 86
50	R0723 550 80	R0723 550 89	R0723 550 86

- 85 Shaft length 900 mm
- 87 Shaft length 1200 mm
- 88 Shaft length 2000 mm

¹⁾ Also available with tubular shaft to $\varnothing 25$ R0723...-69 or
with corrosion-resistant steel shaft to DIN 17230 / EN 10088: R0723-...-79.

Dimensions

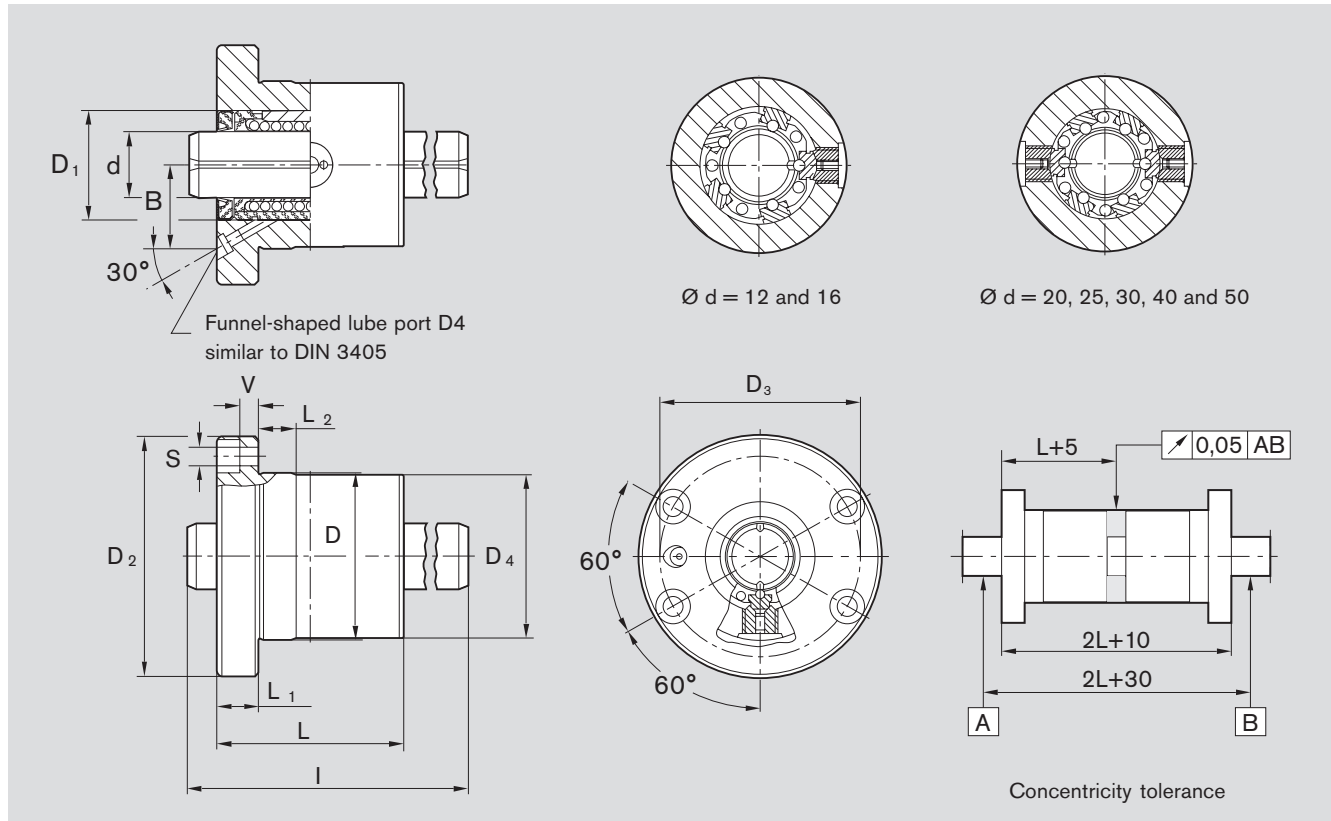

Ø d	Dimensions [mm]											Standard length [mm] I	Torque M _t [Nm]	Load Capacities ²⁾ [N]		Mass	
	D h6	D ₄ -0.1 -0.3	D ₁	D ₂	L h11	L ₁ -0.2	L ₂	D ₃	S ¹⁾	V	B			dyn. C	stat. C ₀	Linear set [kg]	Shaft [kg/m]
12	32	32	22	50	40	10	10	40	4.5	4.5	17.4	400	2	640	420	0.25	0.89
16	36	36	26	54	44	10	10	44	4.5	4.5	20	400	3.3	780	530	0.30	1.57
20	48	48	32	70	55	12	10	58	5.5	5	24	500	12	1550	1050	0.70	2.45
25	56	56	40	82	68	14	10	68	6.6	5.5	29	500	24	3030	2180	1.10	3.80
30	65	65	47	98	80	18	10	80	9	7	33	600	37	3680	2790	1.75	5.50
40	80	80	62	114	92	18	16	95	9	7	41.7	600	86	6320	4350	2.50	9.80
50	100	100	75	140	114	22	16	118	11	8.5	50.5	600	167	9250	6470	4.85	15.30

¹⁾ Mounting screws to ISO 4762-8.8.

²⁾ The load capacities are minimum values as the position and direction of load cannot always be precisely defined.

The figures for dynamic load-carrying capacity have been calculated assuming a nominal travel of 100,000 m. For a nominal travel of 50,000 m, the 'C' figures in the table must be multiplied by a factor of 1.26.

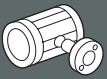

Torque-resistant Linear Bushings with four ball guide grooves

Torque-resistant Linear Bushings, R0724 2
with four ball guide grooves

Structural design

- Hardened and ground sleeve
- Plastic ball retainer
- Balls made of anti-friction bearing steel
- External seals
- Keyway for torque transmission
- Easy re-lubrication



Sizes	Part numbers	Mass [kg]
4	R0724 204 00	0.0065
6	R0724 206 00	0.019
8	R0724 208 00	0.023
10	R0724 210 00	0.054
13	R0724 213 00	0.07
16	R0724 216 00	0.15
20	R0724 220 00	0.20
25	R0724 225 00	0.22
30	R0724 230 00	0.35
40	R0724 240 00	0.81
50	R0724 250 00	1.50

Precision steel shaft R0724 0
with four ball guide grooves

For torque-resistant Linear Bushings R0724, Flanged R0725, Miniature-Flange R0726 and Rotational Flange R0727

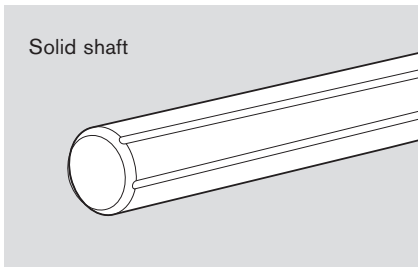

Solid shaft

Sizes	Part numbers solid shaft			Mass [kg/m]
	Shaft length l max.	Shaft to specified length	Customized shaft	
4	R0724 004 02	R0724 004 89	R0724 004 86	0.10
6	R0724 006 02	R0724 006 89	R0724 006 86	0.21
8	R0724 008 02	R0724 008 89	R0724 008 86	0.38
10	R0724 010 02	R0724 010 89	R0724 010 86	0.60
13	R0724 013 02	R0724 013 89	R0724 013 86	1.00
16	R0724 016 02	R0724 016 89	R0724 016 86	1.50
20	R0724 020 02	R0724 020 89	R0724 020 86	2.00
25	R0724 025 02	R0724 025 89	R0724 025 86	3.10
30	R0724 030 02	R0724 030 89	R0724 030 86	4.80
40	R0724 040 02	R0724 040 89	R0724 040 86	8.60
50	R0724 050 02	R0724 050 89	R0724 050 86	13.10

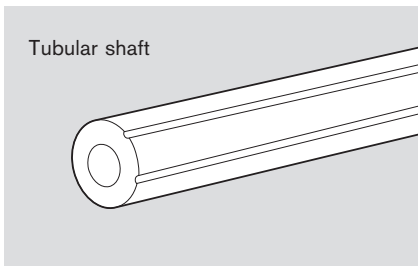

Tubular shaft

Sizes ¹⁾	Part numbers tubular shaft			Mass [kg/m]
	Shaft length l max.	Shaft to specified length	Customized shaft	
4	R0724 004 32	R0724 004 69	R0724 004 66	0.082
6	R0724 006 32	R0724 006 69	R0724 006 66	0.195
8	R0724 008 32	R0724 008 69	R0724 008 66	0.34
10	R0724 010 32	R0724 010 69	R0724 010 66	0.51
13	R0724 013 32	R0724 013 69	R0724 013 66	0.80
16	R0724 016 32	R0724 016 69	R0724 016 66	1.20

¹⁾ Sizes 20 to 50 on request

Dimensions R0724 2

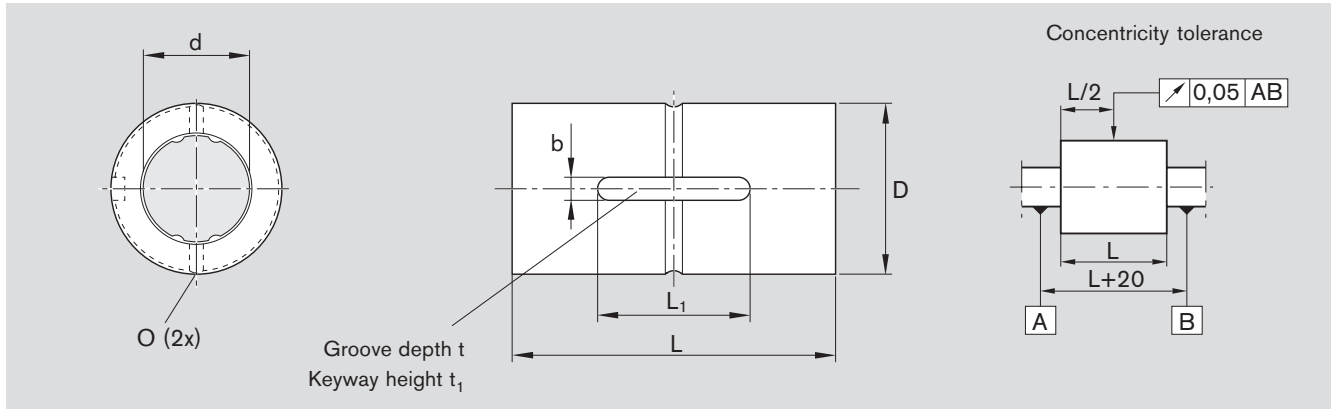

Sizes	Dimensions [mm]								Torque [Nm]		Load Capacities ¹⁾ [N]	
	Ø d	D h6	L	L ₁	O	t	t ₁	b	dyn. M _t	stat. M _{t0}	dyn. C	stat. C ₀
4	4	10	16 _{-0.2}	6	–	1.2	2	2	0.59	1.05	680	1220
6	6	14	25 _{-0.2}	10.5	1	1.2	2.5	2.5	1.20	2.40	970	2280
8	8	16	25 _{-0.2}	10.5	1.5	1.2	2.5	2.5	1.70	3.70	1150	2870
10	10	21	33 _{-0.2}	13	1.5	1.5	3	3	3.50	8.20	2170	5070
13	13	24	36 _{-0.2}	15	1.5	1.5	3	3	16.70	39.20	2120	4890
16	16	31	50 _{-0.2}	17.5	2	2	3.5	3.5	48	110	4860	11200
20	18.2	32	60 _{-0.2}	26	2	2.5	4	4	66	133	6200	11300
25	23	37	70 _{-0.3}	33	3	3	5	5	129	239	9800	16100
30	28	45	80 _{-0.3}	41	3	4	7	7	229	412	14800	23200
40	37.4	60	100 _{-0.3}	55	4	4.5	8	10	500	882	24400	37500
50	47	75	112 _{-0.3}	60	4	5	10	15	1100	3180	36600	74200

¹⁾ The load capacities are minimum values as the position and direction of load cannot always be precisely defined.

The figures for dynamic load-carrying capacity have been calculated assuming a nominal travel of 100,000 m. For a nominal travel of 50,000 m, the 'C' figures in the table must be multiplied by a factor of 1.26.

Mounting instructions:

Recommended bore tolerance: H6 or H7.

Radial clearance: approx. $\pm 5 \mu\text{m}$; with preload upon request

If the shaft had been removed, it is necessary to loosen the adjusting screws and re-adjust the torque-resistant Linear Bushing.

Dimensions R0724 0

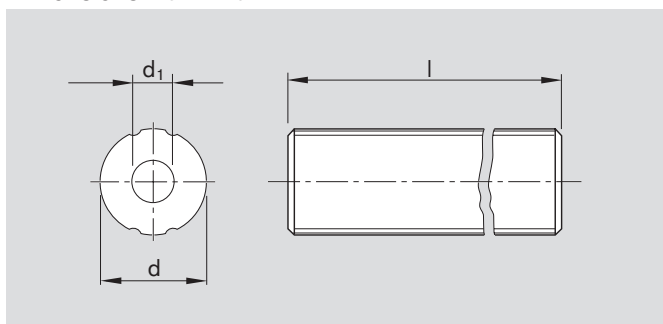

Sizes	Dimensions [mm]		
	Ø d h7	d ₁	Shaft length l _{max}
4	4	1.5	300
6	6	2	600
8	8	3	600
10	10	4	600
13	13	6	600
16	16	8	600
20	18.2	–	1500
25	23	–	1500
30	28	–	1500
40	37.4	–	1800
50	47	–	1800

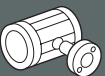

Torque-resistant Linear Bushings with four ball guide grooves

Torque-resistant Linear Bushings, R0725
flanged with four ball guide groovesTorque-resistant Linear Bushings, R0726
Miniature flanged with four ball guide grooves

Structural design

- Hardened and ground sleeve
- Plastic ball retainer
- Balls made of anti-friction bearing steel
- External seals
- Easy re-lubrication



Sizes	Part numbers	Mass [kg]
6	R0725 206 00	0.037
8	R0725 208 00	0.042
10	R0725 210 00	0.094
13	R0725 213 00	0.10
16	R0725 216 00	0.20
20	R0725 220 00	0.22
25	R0725 225 00	0.32
30	R0725 230 00	0.51
40	R0725 240 00	1.15
50	R0725 250 00	2.10

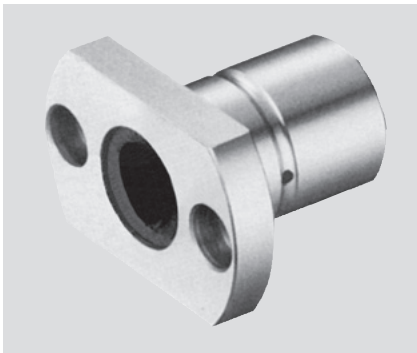

Sizes	Part numbers	Mass [kg]
6	R0726 206 00	0.029
8	R0726 208 00	0.035
10	R0726 210 00	0.075

Note:

For suitable Shafts see "Precision steel shafts R0724 0 with four ball guide grooves"

The figures for dynamic load-carrying capacity have been calculated assuming a nominal travel of 100,000 m. For a nominal travel of 50,000 m, the 'C' figures in the table must be multiplied by a factor of 1.26.

Mounting instructions:

Recommended bore tolerance: H6 or H7.

Radial clearance: approx. $\pm 5 \mu\text{m}$; with tensioning upon request

If the shaft had been removed, it is necessary to loosen the adjusting screws and re-adjust the torque-resistant Linear Bushing.

Dimensions R0725

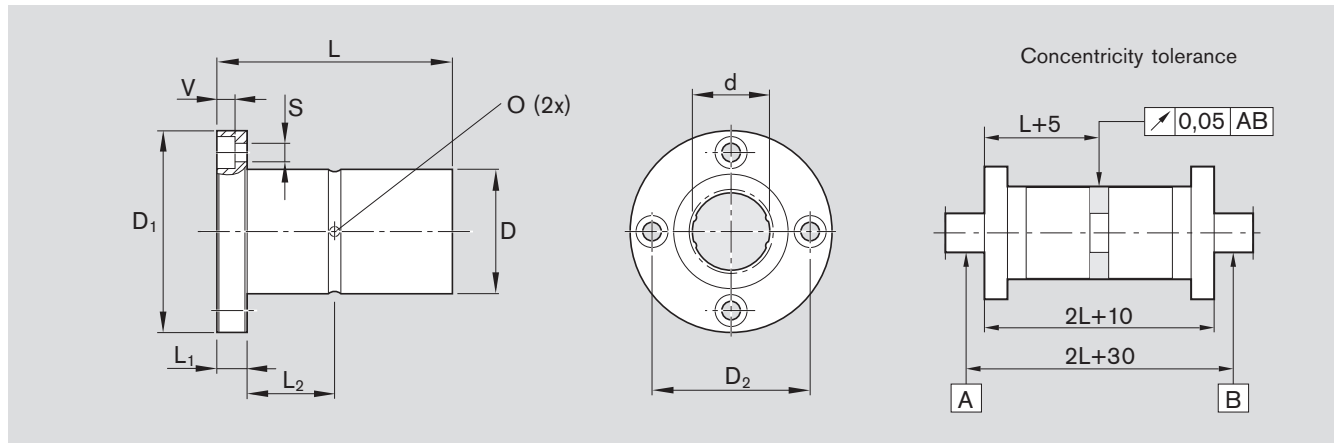

Sizes	Dimensions [mm]											Torque-resistant [Nm]		Load Capacities ¹⁾ [N]	
	Ø d	D h6	D ₁	D ₂	L	L ₁	L ₂	V	S ²⁾	O	dyn. M _t	stat. M _{t0}	dyn. C	stat. C ₀	
6	6	14	30	22	25 _{-0.2}	5	7.5	3.3	3.4	1	1.2	2.4	970	2280	
8	8	16	32	24	25 _{-0.2}	5	7.5	3.3	3.4	1.5	1.7	3.7	1150	2870	
10	10	21	42	32	33 _{-0.2}	6	10.5	4.4	4.5	1.5	3.5	8.2	2170	5070	
13	13	24	43	33	36 _{-0.2}	7	11	4.4	4.5	1.5	16.7	39.2	2120	4890	
16	16	31	50	40	50 _{-0.2}	7	18	4.4	4.5	2	48	110	4860	11200	
20	18.2	32	51	40	60 _{-0.2}	7	23	4.4	4.5	2	66	133	6200	11300	
25	23	37	60	47	70 _{-0.3}	9	26	5.4	5.5	3	129	239	9800	16100	
30	28	45	70	54	80 _{-0.3}	10	30	6.5	6.6	3	229	412	14800	23200	
40	37.4	60	90	72	100 _{-0.3}	14	36	8.6	9	4	500	882	24400	37500	
50	47	75	113	91	112 _{-0.3}	16	40	11	11	4	1100	3180	36600	74200	

Dimensions R0726

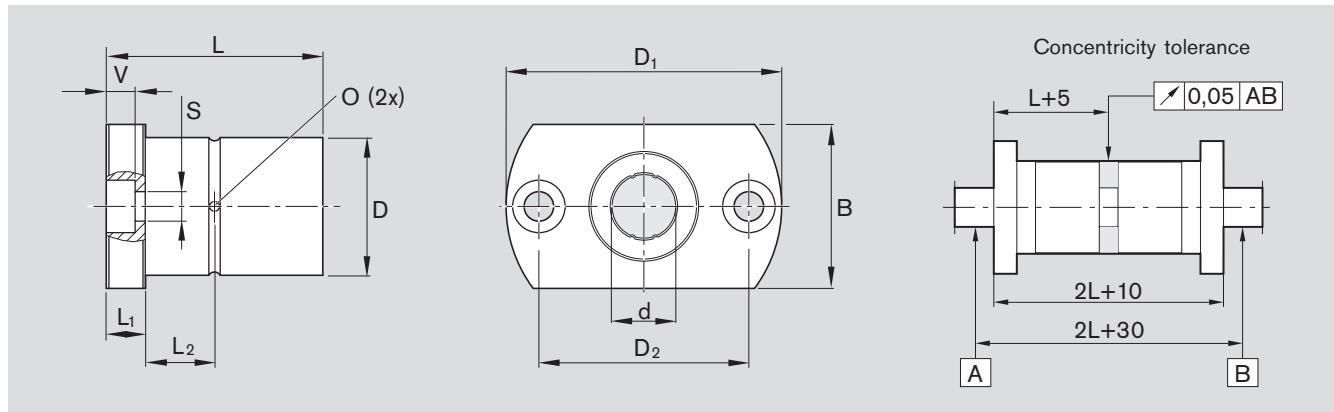

Sizes	Dimensions [mm]											Torque [Nm]		Load Capacities ¹⁾ [N]	
	Ø d	D h6	D ₁	D ₂	B	L -0.2	L ₁	L ₂	V	S ²⁾	O	dyn. M _t	stat. M _{t0}	dyn. C	stat. C ₀
6	6	14	30	22	18	25	5	7.5	3.3	3.4	1	1.2	2.4	970	2280
8	8	16	32	24	21	25	5	7.5	3.3	3.4	1.5	1.7	3.7	1150	2870
10	10	21	42	32	25	33	6	10.5	4.4	4.5	1.5	3.5	8.2	2170	5070

¹⁾ The load capacities are minimum values as the position and direction of load cannot always be precisely defined.

²⁾ Mounting screws to ISO 4762-8.8



Torque-resistant Linear Bushings with four ball guide grooves

Torque-resistant Linear Bushings, R0727
Rotational flanged with four ball guide grooves

Structural design

- Hardened and ground sleeve
- Plastic ball retainer
- Balls made of anti-friction bearing steel
- External seals
- Integrated cross-roller bearing



Sizes	Part numbers	Mass [kg]
20	R0727 220 00	0.45
25	R0727 225 00	0.75
30	R0727 230 00	1.25
40	R0727 240 00	2.30

Note:

For suitable Shafts see "Precision steel shafts R0724 0 with four ball guide grooves"

Dimensions

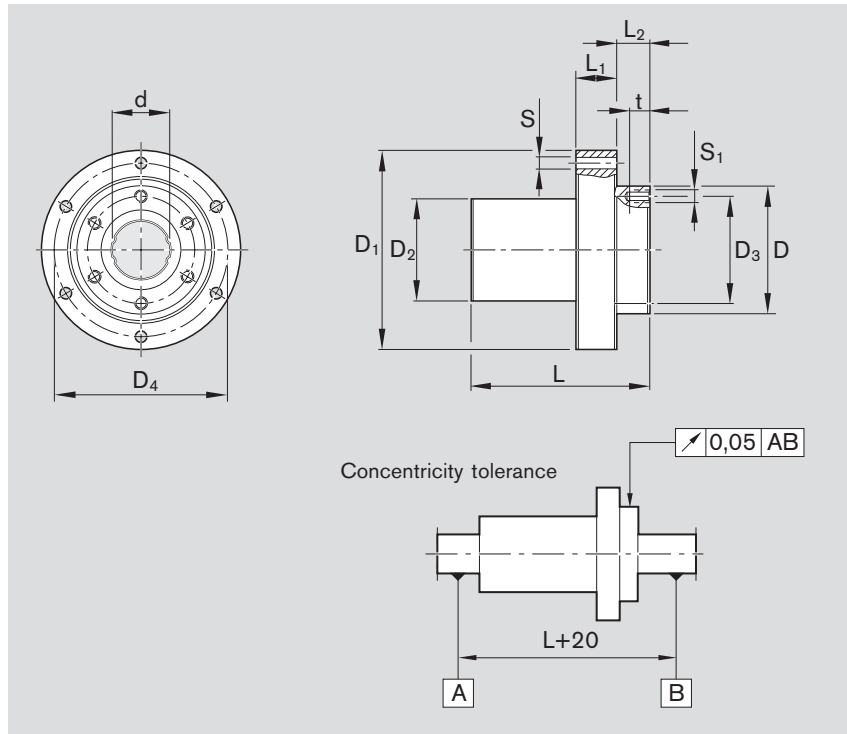

Installation recommendation

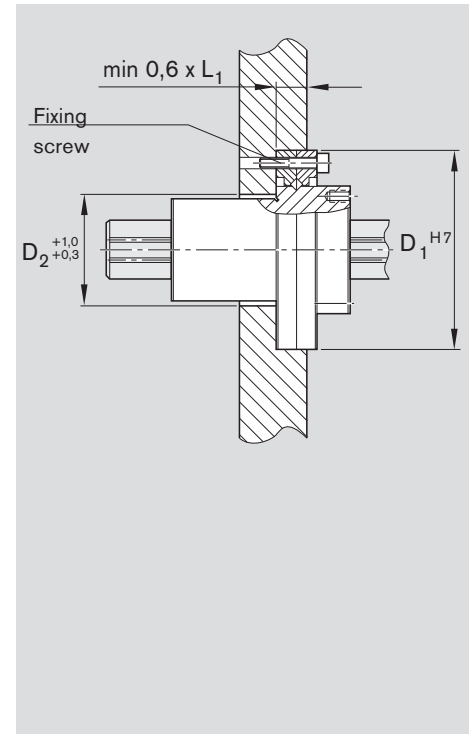

Sizes	Dimensions [mm]											
	Ø d	D h7	D ₁ h7	D ₂	D ₃	D ₄	L	L ₁	L ₂	S	S ₁	t
20	18.2	40	66	34	34	56	60 _{-0.2}	13	12	4.5	M4	7
25	23	50	78	40	42	68	70 _{-0.3}	16	13	4.5	M5	8
30	28	61	100	47	52	86	80 _{-0.3}	17	17	6.6	M6	10
40	37.4	76	120	62	64	104	100 _{-0.3}	20	23	9	M6	10

Sizes	Torque-resistant Linear Bushings				Cross roller bearing			Tightening torque	
	Torque-resistant [Nm]		Load Capacities ¹⁾ [N]		Load Capacities [N]		Rotational limit	Fixing screw	
	dyn. M _t	stat. M _{to}	dyn. C	stat. C _o	dyn. C	stat. C _o	[min ⁻¹]		[Nm]
20	66	133	6200	11300	5900	7350	1200	M4	3.9
25	129	239	9800	16100	9110	11500	1000	M4	3.9
30	229	412	14800	23200	13200	18000	800	M6	12.7
40	500	882	24400	37500	22800	32300	600	M8	29.4

¹⁾ The load capacities are minimum values as the position and direction of load cannot always be precisely defined.

The figures for dynamic load-carrying capacity have been calculated assuming a nominal travel of 100,000 m. For a nominal travel of 50,000 m, the 'C' figures in the table must be multiplied by a factor of 1.26.

Mounting instructions:

Radial clearance: approx. ± 5 µm; with preloading upon request
 If the shaft has been removed, it is necessary to loosen the adjusting screws and re-adjust the torque-resistant Linear Bushing.

 Do not loosen Flanged screw (cross-roller bearing). Turn the fixing screw step by step to the values in the table.

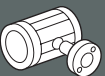

Linear Bushings for combined linear and rotary motion

The advantages

- Linear Bushings with grooved ball bearings or needle roller bearings
- Precise travel at high capacity
- High RPMs and minimal friction
- For linear applications with additional rotation
- For grip and swivel functions
- For winding applications

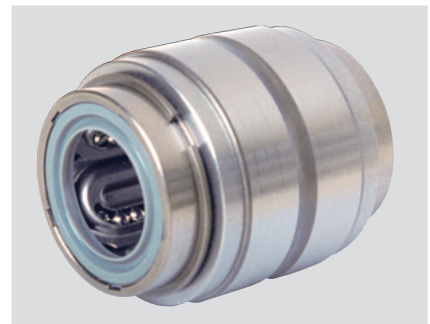
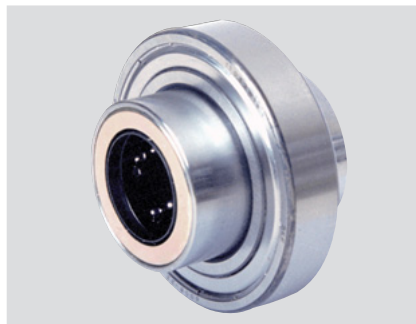

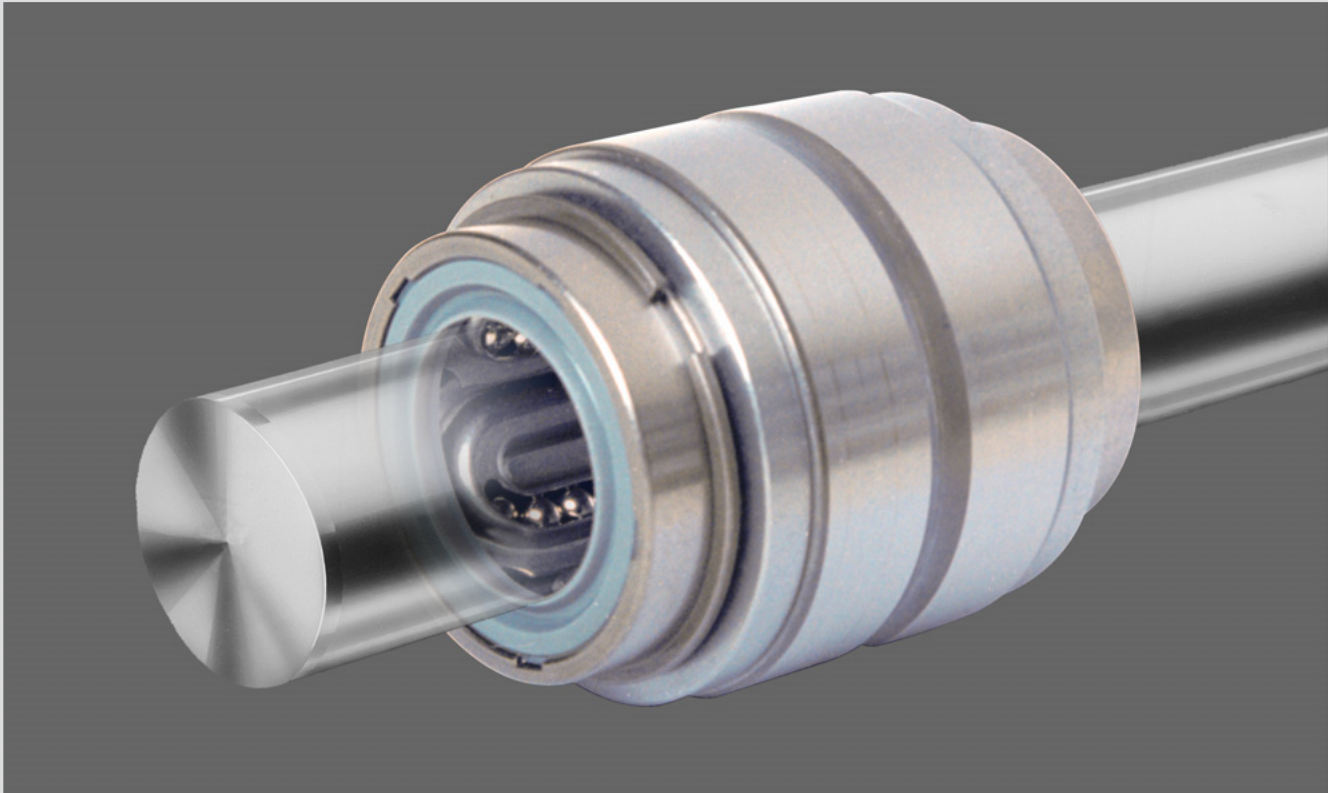

Linear Bushings for combined linear and rotary motion

Linear Bushings for combined linear and rotary motion, R0663 with deep groove ball bearings, Series 618

Linear Bushings for combined linear and rotary motion, R0664 with deep groove ball bearings, Series 60

Structural design

- Maintenance-free and sealed with shields (Series 60)

Sizes 12 to 40

- Segmental Linear Bushing
- Steel sleeve
- External wiper seals
- Pressed-on deep groove ball bearings

Sizes 5, 8, 50, 60 and 80

- Standard Linear Bushing
- Internal seals
- Pressed-on deep groove ball bearings

with series 618 deep groove ball bearings
Series 618 (Sizes 12 to 40)



Shaft Ø d [mm]	Part numbers with series 618 deep grooved ball bearings	Mass [kg]
5	R0663 205 00	0.02
8	R0663 208 00	0.06
12	R0663 212 00	0.08
16	R0663 216 00	0.11
20	R0663 220 00	0.15
25	R0663 225 00	0.17
30	R0663 230 00	0.35
40	R0663 240 00	0.49
50	R0663 250 00	1.29
60	R0663 260 00	2.39
80	R0663 280 00	5.35

(Sizes 5, 8, 50, 60 and 80)



with series 60 deep groove ball bearings

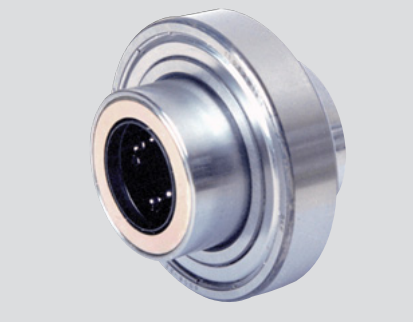

Shaft Ø d [mm]	Part numbers with series 60 deep grooved ball bearings	Mass [kg]
5	R0664 205 00	0.03
8	R0664 208 00	0.11
12	R0664 212 00	0.14
16	R0664 216 00	0.20
20	R0664 220 00	0.27
25	R0664 225 00	0.32
30	R0664 230 00	0.56
40	R0664 240 00	0.87
50	R0664 250 00	1.78
60	R0664 260 00	3.26

Dimensions

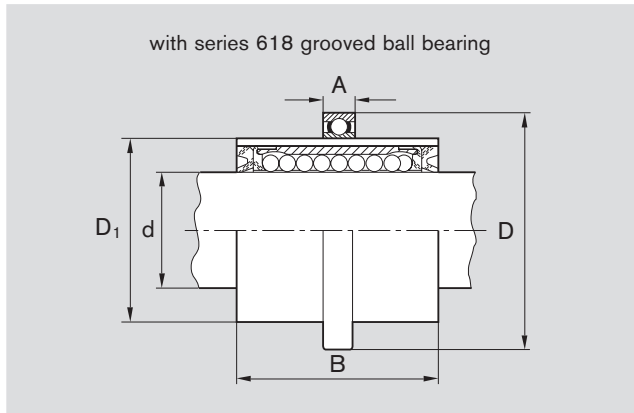

Ød	Dimensions [mm]				Load capacities ³⁾ [N]	
	D	D ₁	A	B	dyn. C	stat. C ₀
5	21	12 ¹⁾	5	22	180	140
8 ²⁾	32	20	7	25	320	240
12	37	25	7	30	480	420
16	42	30	7	34	720	620
20	47	35	7	38	1020	870
25	52	40	7	45	1630	1360
30	65	50	7	54	2390	1960
40	78	60	10	66	3870	3270
50	95	75 ¹⁾	10	100	8260	6470
60	115	90 ¹⁾	13	125	11500	9160
80	150	120 ¹⁾	16	165	21000	16300

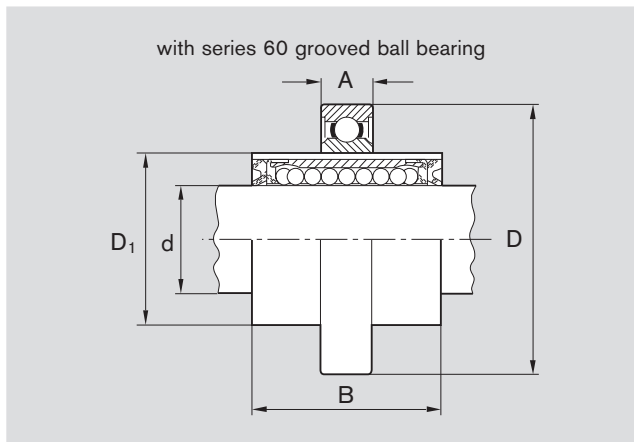

Ød	Dimensions [mm]				Load capacities ³⁾ [N]	
	D	D ₁	A	B	dyn. C	stat. C ₀
5	28	12 ¹⁾	8	22	180	140
8 ²⁾	42	20	12	25	320	240
12	47	25	12	30	480	420
16	55	30	13	34	720	620
20	62	35	14	38	1020	870
25	68	40	15	45	1630	1360
30	80	50	16	54	2390	1960
40	95	60	18	66	3870	3270
50	115	75 ¹⁾	20	100	8260	6470
60	140	90 ¹⁾	24	125	11500	9160

¹⁾ Oversized

²⁾ A spacer sleeve is located between the ball bearing and the Standard Linear Bushing.

³⁾ The figures given for load capacity are minimum values as the position and load direction cannot be precisely defined.

The figures for dynamic load-carrying capacity have been calculated assuming a nominal travel of 100,000 m. For a nominal travel of 50,000 m, the 'C' figures in the tables opposite must be multiplied by a factor of 1.26.

Sealing:

The linear bushings are sealed at both ends.

Series R0663: If the deep groove ball bearings are to be sealed with shaft seals, please request table 06/060-00.

Series R0664: In all sizes the deep groove ball bearings are maintenance-free with shields at both ends.

Recommended tolerances

Series R0663 And R0664: Shaft: d_{h6}

Housing bore D^{K6} or D^{K7}

Other tolerance zones may be selected for special purposes

(refer to the anti-friction bearing manufacturer's mounting recommendations).



Linear Bushings for combined linear and rotary motion

Linear Bushings for combined linear and rotary motion, R0665
with needle roller bearings without wiper seal

Linear Bushings for combined linear and rotary motion, R0667
with needle roller bearings with wiper seal

Structural design

- Standard Linear Bushing (closed type)
- Needle roller bearings
- Steel spacer rings
- Retaining rings



Shaft Ø d [mm]	Part numbers		Mass [kg]
	with two seals	without seals	
5	R0667 005 00	R0665 005 00	0.02
8	R0667 008 00	R0665 008 00	0.04
12	R0667 012 00	R0665 012 00	0.08
16	R0667 016 00	R0665 016 00	0.10
20	R0667 020 00	R0665 020 00	0.20
25	R0667 025 00	R0665 025 00	0.34
30	R0667 030 00	R0665 030 00	0.56
40	R0667 040 00	R0665 040 00	1.39
50	R0667 050 00	R0665 050 00	2.18
60	R0667 060 00	R0665 060 00	4.14
80	R0667 080 00	R0665 080 00	7.11

Dimensions

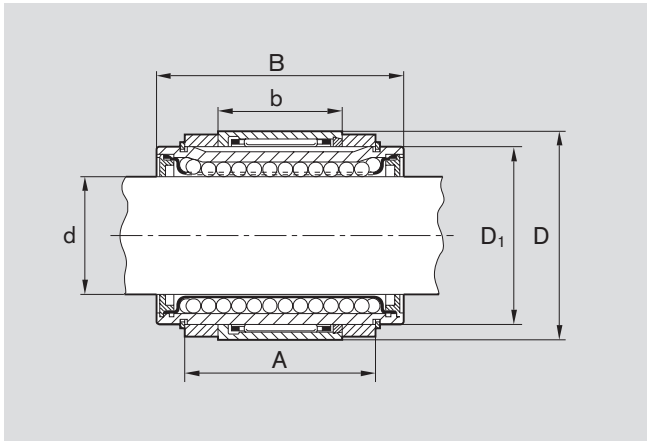

Installation recommendation

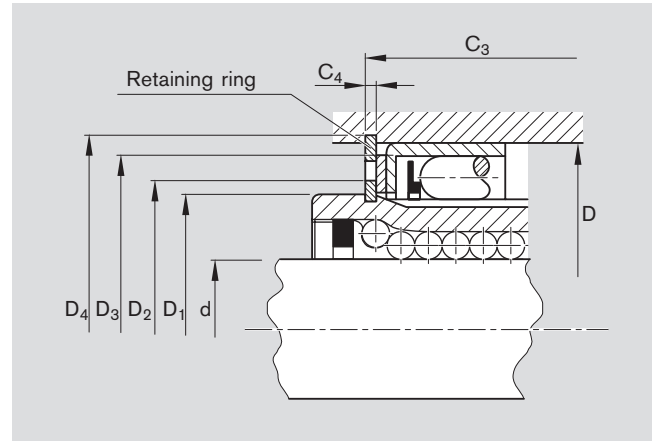

Ø d	D	D ₁	b	Dimensions [mm]							Retaining ring ⁴⁾	Load capacities ⁵⁾ [N]	
				A	B	D ₂	D ₃	D ₄ H11	C ₃ H13	C ₄ H13		dyn. C	stat. C ₀
5 ¹⁾	19	12	12	12	22	13.8	–	19.5	14.6	1.3	SB19	180	140
8 ¹⁾	24	16	13	14.1	25	19.3	23	24.8	16.5	1.3	SB24	320	240
12	30	22	16	20	32	24.2	28	31	23.2	1.6	SB30	420	280
16	34	26	20	22.1	36	28.4	32	35	25.3	1.6	SB34	580	440
20	42	32	20	28	45	35.1	40	43.2	31.2	1.6	SB42	1170	860
25	50	40	30	40	58	43.1	48	51.2	43.2	1.6	SB50	2080	1560
30	57	47	30	48	68	49.1	55	58.5	51.2	1.6	SB57	2820	2230
40 ²⁾	80	62.1 ³⁾	56	56	80	74.2	–	81.8	60.2	2.2	SB80	5170	3810
50 ²⁾	92	75	70	73.1	100	80.6	90	94	78.3	2.7	SB92	8260	6470
60 ²⁾	110	90	70	95	125	95	108	112.3	100.2	2.7	SB110	11500	9160
80 ²⁾	140	120	81.6	125	165	128	138	122.3	130.2	2.7	SB140	21000	16300

¹⁾ With plastic ball retainer

²⁾ Contrary to the illustration, these sizes have two needle roller bearings.

³⁾ The basic body is a special version of the closed standard Linear Bushing.

⁴⁾ Seeger-Orbis GmbH

⁵⁾ The figures given for load capacity are minimum values as the position and load direction cannot be precisely defined.

The figures for dynamic load-carrying capacity have been calculated assuming a nominal travel of 100,000 m. For a nominal travel of 50,000 m, the 'C' figures in the tables opposite must be multiplied by a factor of 1.26.

Recommended tolerances

Shaft d_{h6}

Housing bore D^{K6} bzw. D^{K7}

In special circumstances, another Tolerance can be specified (refer to the anti-friction bearing manufacturer's mounting recommendation)

For axial adjustment of the needle roller bearings in the housing, see installation recommendation.

The installation of the needle roller bearings in the housing without additional axial adjustment is sufficient for many applications.



Precision steel shafts

The Advantages

- Induction hardened and ground
- Solid or tubular shafts
- Available in various tolerances
- Available in heat-treated steel, corrosion-resistant steel or hard chromium plated steel
- Cut to customer specified lengths
- With chamfers to protect the Linear Bushing seal
- Completed per customer design
- As a guidance shaft for Linear Bushings
- As rollers, pistons and axles



Precision steel shafts

Overview

Measurements

Shaft Ø d [mm]	Part numbers					
	Heat-treated steel		Solid shafts X46Cr13		X90CrMoV18	
	h6	h7	h6	h7	h6	h7
3	R1000 003 00				R1000 003 20	
4	R1000 004 00	R1000 004 01	R1000 004 30	R1000 004 31		
5	R1000 005 00	R1000 005 01	R1000 005 30	R1000 005 31		
6	R1000 006 00	R1000 006 01	R1000 006 30	R1000 006 31		
8	R1000 008 00	R1000 008 01	R1000 008 30	R1000 008 31		
10	R1000 010 00	R1000 010 01	R1000 010 30	R1000 010 31		
12	R1000 012 00	R1000 012 01	R1000 012 30	R1000 012 31	R1000 012 20	R1000 012 21
14	R1000 014 00	R1000 014 01	R1000 014 30	R1000 014 31		
15	R1000 015 00	R1000 015 01				
16	R1000 016 00	R1000 016 01	R1000 016 30	R1000 016 31	R1000 016 20	R1000 016 21
18	R1000 018 00	R1000 018 01				
20	R1000 020 00	R1000 020 01	R1000 020 30	R1000 020 31	R1000 020 20	R1000 020 21
22	R1000 022 00	R1000 022 01				
24	R1000 024 00	R1000 024 01				
25	R1000 025 00	R1000 025 01	R1000 025 30	R1000 025 31	R1000 025 20	R1000 025 21
30	R1000 030 00	R1000 030 01	R1000 030 30	R1000 030 31	R1000 030 20	R1000 030 21
32	R1000 032 00	R1000 032 01				
35	R1000 035 00	R1000 035 01				
38	R1000 038 00	R1000 038 01				
40	R1000 040 00	R1000 040 01	R1000 040 30	R1000 040 31	R1000 040 20	R1000 040 21
45	R1000 045 00	R1000 045 01				
50	R1000 050 00	R1000 050 01	R1000 050 30	R1000 050 31	R1000 050 20	R1000 050 21
55	R1000 055 00	R1000 055 01				
60	R1000 060 00	R1000 060 01	R1000 060 30	R1000 060 31	R1000 060 20	R1000 060 21
70	R1000 070 00	R1000 070 01				
80	R1000 080 00	R1000 080 01	R1000 080 30	R1000 080 31	R1000 080 20	R1000 080 21
100	R1000 100 00	R1000 100 01				
110	R1000 110 00	R1000 110 01				

Shaft Ø d [mm]	Part numbers				
	Solid Shaft		Tubular shaft		
	Hard chromium plating		Heat-treated steel		Hard chromium plating
	h6	h7	h6	h7	h7
3					
4					
5					
6					
8			R1001 008 10		
10			R1001 010 10		
12	R1000 012 60	R1000 012 61	R1001 012 10	R1001 012 11	
14					
15					
16	R1000 016 60	R1000 016 61	R1001 016 10		
18					
20	R1000 020 60	R1000 020 61	R1001 020 10	R1001 020 11	
22					
24					
25	R1000 025 60	R1000 025 61	R1001 025 10	R1001 025 11	R1001 025 41
30	R1000 030 60	R1000 030 61	R1001 030 10	R1001 030 11	R1001 030 41
32					
35					
38					
40	R1000 040 60	R1000 040 61	R1001 040 10	R1001 040 11	R1001 040 41
45					
50	R1000 050 60	R1000 050 61	R1001 050 10	R1001 050 11	R1001 050 41
55					
60	R1000 060 60	R1000 060 61	R1001 060 10	R1001 060 11	R1001 060 41
70					
80	R1000 080 60	R1000 080 61	R1001 080 10	R1001 080 11	R1001 080 41
100			R1001 100 10	R1001 100 11	
110					



Precision steel shafts

Technical Data

Dimensional accuracy and tolerance zones

The diameters of Precision Steel Shafts are accurate to within the tolerance zones h6 and h7. Details on the dimensional accuracy of the shafts are compiled in the tables on the right. The tolerance for the diameter of soft-annealed shaft sections may go slightly beyond the tolerance zones quoted.

By request: Precision Steel Shafts may also be supplied in tolerance zone h5 (standard diameters 30 to 80 only). For special diameter tolerances, please consult us.

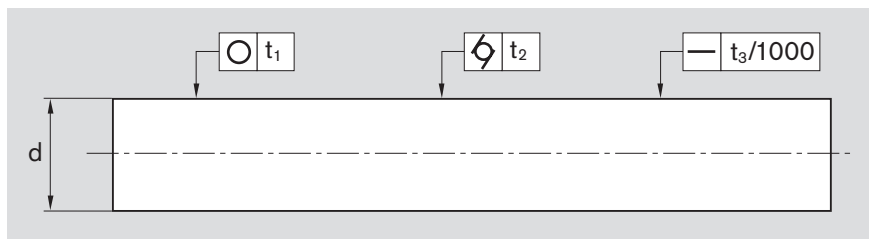

Nominal diameter d [mm]	over	1	3	6	10	18	30	50	80
	to	3	6	10	18	30	50	80	120
Diameter tolerance [µm]	h6	0	0	0	0	0	0	0	0
		-6	-8	-9	-11	-13	-16	-19	-22
	h7	0	0	0	0	0	0	0	0
		-10	-12	-15	-18	-21	-25	-30	-35
Roundness t ₁ [µm]	h6	3	4	4	5	6	7	8	10
	h7	4	5	6	8	9	11	13	15
Taper t ₂ ¹⁾ [µm]	h6	4	5	6	8	9	11	13	15
	h7	6	8	9	11	13	16	19	22
Straightness t ₃ ²⁾ [µm/m]		150	150	120	100	100	100	100	100
Surface roughness (Ra) ³⁾ [µm]		0.32	0.32	0.32	0.32	0.32	0.32	0.32	0.32

¹⁾ Dial gauge reading during straightness measurement. For lengths of less than 1 m the lowest possible value is 40 µm. This corresponds to a straightness tolerance of 20 µm.

²⁾ Applies to shafts made of heat-treatable or anti-friction bearing steel only.

Please contact us for surface finish and surface roughness (R_a) tolerances for hard chrome plated and corrosion-resistant steel shafts.

Measurement of straightness per ISO 13012

Measurements are performed at points equidistant between the support points and the overhanging ends of the shaft. The measured values are half the gage measurement when the shaft is rotated by 360°.

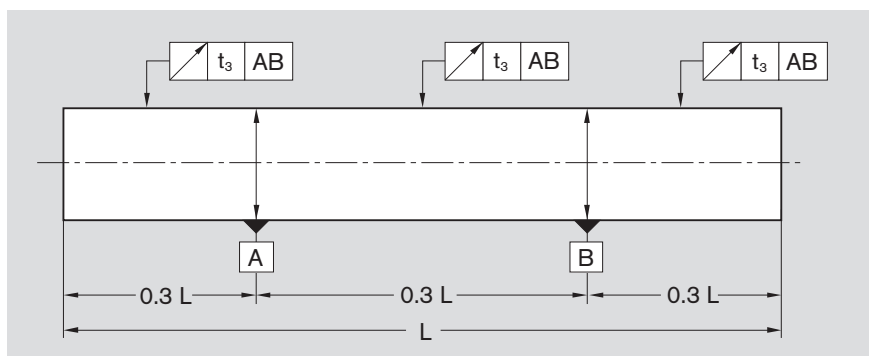

Measurement of roundness

The drawing shows the roundness of a raw shaft in comparison to a precision steel shaft.

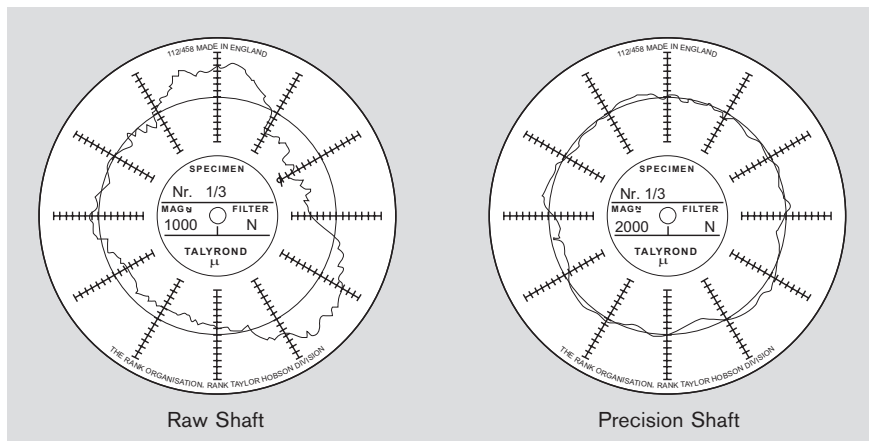

Shaft hardness

The surface of the shaft is induction-hardened to a depth of at least 0.4 up to 3.2 mm, depending on the shaft diameter. Surface hardness and depth of hardness are extremely uniform, both in the axial and in the circumferential direction. This is the reason for the excellent dimensional consistency and the long service life of Precision Steel Shafts.

The photographs opposite show a longitudinal and a transverse section through a hardened and ground Precision Steel Shaft.

The hardened surface zone has been made visible by caustic etching.

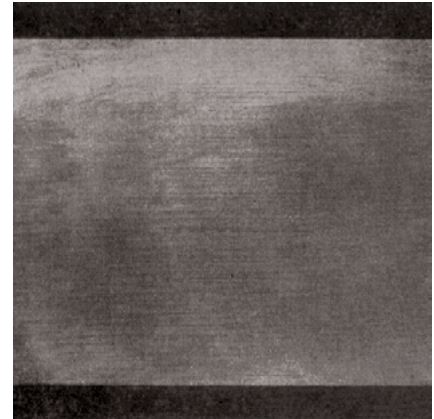

Shaft Ø d [mm]	over	1	3	10	18	30	50	80
	to	3	10	18	30	50	80	120
Hardness depth ¹⁾ [mm]	min.	0.4	0.4	0.6	0.9	1.5	2.2	3.2

¹⁾Please contact us to obtain the depth of hardness for corrosion-resistant steel shafts.

Minimum hardness

Solid and tubular shafts → HRC 60

Corrosion-resistant steel shafts to ISO 683-17/ EN 10088 → HRC 54

The graphic shows the micro-structure in the surface zone of a shaft cross section (magnification approx. 10x). The hardened outer layer of martensite and the smooth transition to the tough inner core structure are clearly visible.



Induction hardened surface zone
Structure: Martensite
hardness ≥ HRC 60 (Rockwell C)

Transitional structure:
Martensite
Troostite
Pearlite

Core structure:
Pearlite and ferrite

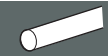

Precision steel shafts

Technical Data

Shaft deflection

When steel shafts are used as linear motion guideways for linear bushings it is important that the shaft deflection occurring under load is kept within certain limits, as otherwise the proper functioning and the service life of the assembly could be impaired¹⁾.

To facilitate the determination of shaft deflection by calculation, we have compiled the most common load cases together with the associated deflection equations in the table below.

The equations for calculation of the inclination of the shaft in the linear bushing ($\tan \alpha$) can also be taken from this table.

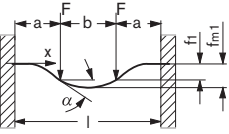
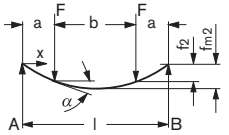
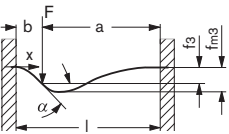
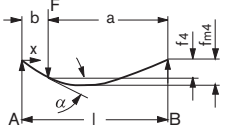
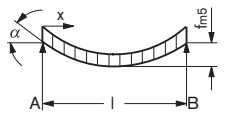
Case No.	Loading conditions	Deflection equation	Shaft inclination in linear bushings
1		$f_1 = \frac{F \cdot a^3}{6 \cdot E \cdot J} \cdot \left(2 - \frac{3 \cdot a}{l}\right)$ $f_{m1} = \frac{F \cdot a^2}{24 \cdot E \cdot J} \cdot (3l - 4a)$	$\tan \alpha_{(x=a)} = \frac{F \cdot a^2 \cdot b}{2 \cdot E \cdot J \cdot l}$
2		$f_2 = \frac{F \cdot l^3}{2 \cdot E \cdot J} \cdot \frac{a^2}{l^2} \cdot \left(1 - \frac{4}{3} \cdot \frac{a}{l}\right)$ $f_{m2} = \frac{F \cdot l^3}{8 \cdot E \cdot J} \cdot \frac{a}{l} \cdot \left(1 - \frac{4}{3} \cdot \frac{a^2}{l^2}\right)$	$\tan \alpha_{(x=a)} = \frac{F \cdot a \cdot b}{2 \cdot E \cdot J}$
3		$f_3 = \frac{F \cdot l^3}{3 \cdot E \cdot J} \cdot \frac{a^3 \cdot b^3}{l^3 \cdot l^3}$ $f_{m3} = \frac{2 \cdot F \cdot l^3}{3 \cdot E \cdot J} \cdot \frac{a^3}{l^3} \cdot \frac{b^2}{l^2} \cdot \left(\frac{l}{l+2a}\right)^2$	$\tan \alpha_{(x=b)} = \frac{F \cdot a^2 \cdot b^2}{2 \cdot E \cdot J \cdot l^2} \cdot \left(1 - \frac{2 \cdot b}{l}\right)$
4		$f_4 = \frac{F \cdot l^3}{3 \cdot E \cdot J} \cdot \frac{a^2 \cdot b^2}{l^2 \cdot l^2}$ $f_{m4} = f_4 \cdot \frac{l+b}{3 \cdot b} \cdot \sqrt{\frac{l+b}{3 \cdot a}}$	$\tan \alpha_{(x=b)} = \frac{F \cdot a}{6 \cdot E \cdot J \cdot l} \cdot (3b^2 - l^2 + a^2)$
5		$f_5 = \frac{5 \cdot F \cdot l^3}{384 \cdot E \cdot J}$	$\tan \alpha_{(x=0)} = \frac{F \cdot l^2}{24 \cdot E \cdot J}$

¹⁾ There will be no loss of load-carrying capacity or service life in Super Linear Bushings **A**, **H** and **Sb** provided the shaft deflection does not exceed 30' ($\tan 30' = 0.0087$).

The table gives the values for the maximum permissible shaft inclination ($\tan \alpha_{\max}$) for each size of Standard Linear Bushing.

At $\tan \alpha = \tan \alpha_{\max}$ the permissible static load capacity is approx. $0.4 C_0$.

Shaft Ø d [mm]	$\tan \alpha_{\max}$
5	$12.3 \cdot 10^{-4}$
8	$10.0 \cdot 10^{-4}$
12	$10.1 \cdot 10^{-4}$
16	$8.5 \cdot 10^{-4}$
20	$8.5 \cdot 10^{-4}$
25	$7.2 \cdot 10^{-4}$

Shaft Ø d [mm]	$\tan \alpha_{\max}$
30	$6.4 \cdot 10^{-4}$
40	$7.3 \cdot 10^{-4}$
50	$6.3 \cdot 10^{-4}$
60	$5.7 \cdot 10^{-4}$
80	$5.7 \cdot 10^{-4}$

Values for E x J and mass for steel shafts

Ø d [mm]	Solid Shafts	
	E x J [N x mm ²]	Mass [kg/m]
3	$8.35 \cdot 10^5$	0.06
4	$2.64 \cdot 10^6$	0.10
5	$6.44 \cdot 10^6$	0.15
8	$4.22 \cdot 10^7$	0.39
10	$1.03 \cdot 10^8$	0.61
12	$2.14 \cdot 10^8$	0.88
14	$3.96 \cdot 10^8$	1.20
16	$6.76 \cdot 10^8$	1.57
20	$1.65 \cdot 10^9$	2.45
25	$4.03 \cdot 10^9$	3.83
30	$8.35 \cdot 10^9$	5.51
40	$2.64 \cdot 10^{10}$	9.80
50	$6.44 \cdot 10^{10}$	15.32
60	$1.34 \cdot 10^{11}$	22.05
80	$4.22 \cdot 10^{11}$	39.21

Tubular shafts				
Shaft outer [mm]	diameter		E x J [N x mm ²]	Mass [kg/m]
	Inner [mm]			
8	3		$4.14 \cdot 10^7$	0.34
10	4		$1.00 \cdot 10^8$	0.51
12	3.4		$2.12 \cdot 10^8$	0.81
16	8		$6.33 \cdot 10^8$	1.18
20	14		$1.25 \cdot 10^9$	1.25
25	14		$3.63 \cdot 10^9$	2.63
30	19		$7.01 \cdot 10^9$	3.30
40	26.5		$2.13 \cdot 10^{10}$	5.50
50	29.6		$5.65 \cdot 10^{10}$	9.95
60	36.5		$1.15 \cdot 10^{11}$	13.89
80	57.4		$3.10 \cdot 10^{11}$	19.02

Calculation values: Modulus of elasticity = $2.1 \cdot 10^5 \text{ N/mm}^2$
 Seals = 7.8 g/cm^3



Precision steel shafts

Technical Data

Mill-cut lengths

Type of shafts	Diameter [mm]	Mill-cut length ¹⁾ [m]
Solid Shafts ²⁾	3	0.4
	4 to 8	3.6
	ab 10	6.1
Tubular shafts	8 and 10	1
	16	2
	20	5.7
	12 and up to 25	6.1
Corrosion-resistant steel shafts	3	0.4
	4 to 10	3.6
	up to 12	6.1

¹⁾ The first 50 mm at each end of mill-cut lengths may deviate slightly from the nominal diameter.

²⁾ Solid shafts of lengths up to 8 m and Ø 20 and over are available upon request.

Composite shafts
Plug-and-socket joints

We can supply composite shafts for applications requiring a shaft longer than the mill-cut lengths available. The shaft sections are joined together by a spigot-and-recess arrangement, one section having a locating plug and the other a mating hole (see figure below). The joined shaft must rest on a full-length, continuous support rail or must at least be supported at regular intervals with one of the supports located at the joint between the shaft sections (see "Shaft Support Rails").

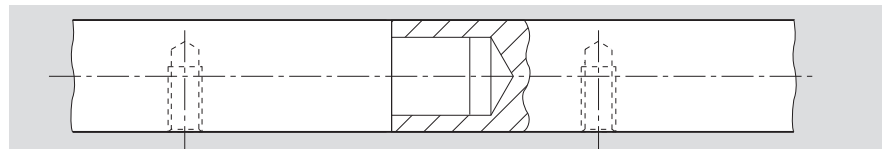

Shafts with threaded joints
(does not apply to corrosion-resistant steel shafts)

At the customer's request, the plug can be threaded and the mating hole tapped (see figure below). Line-up markings are then provided at the ends of the mating shaft sections to facilitate vertical alignment of the radial holes for attachment of the coupled shaft assembly to the shaft support rail.

All machining and marking operations are carried out on the shaft sections after they have been hardened and ground. Since it will not be possible to re-grind the finished joint, extreme care is taken in the machining of the centering arrangement to ensure precision mating of the shaft sections.

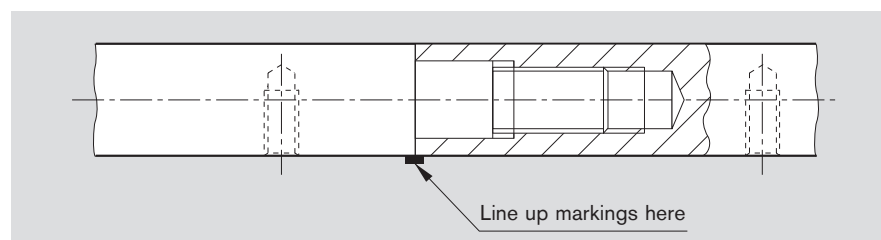

Shaft Machining

Chamfers

Steel shafts intended for use as linear motion guideways for Linear Bushings must be chamfered at the ends to prevent damage to the ball retainers or wipers when the linear bushing is being pushed onto the shaft.

The figure and the table give the dimensions of the chamfers required. Linear bushings with seals must not be pushed over sharp edges in the shaft (e.g. retaining ring grooves), as this would damage the seal lips.

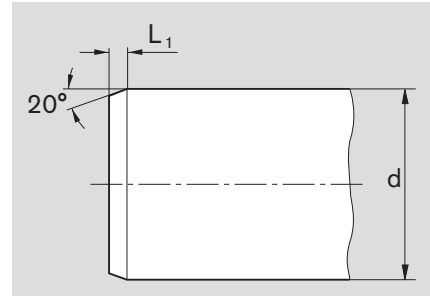

Shaft Ø d [mm]	3	4	5	8	10	12	14	16	20	25	30	40	50	60	80
Length of Chamfer L ₁ [mm]	1	1	1.5	1.5	1.5	2	2	2	2	2	2	3	3	3	3

Machining

Hardened and ground steel shafts in mill-cut lengths are always in stock. These can be cut to any desired length and machined to have any of the following characteristics:

- Reduced diameter ends
- Male or female threads
- Countersinks
- Radial or axial holes
- Recesses
- or other specially machined features.

Annealing of machined sections

Machined shafts may have to be annealed due to the hardened outer zone (slight measurement change possible)

Length tolerances for cut-to-size shafts

Dimensions [mm]	
Length	Tolerance
to 400	±0.5
over 400 to 1000	±0.8
over 1000 to 2000	±1.2
over 2000 to 4000	±2.0
over 4000 to 6000	±3.0
over 6000 to 8000	±3.5

Steel shafts with closer length tolerance can also be supplied at a surcharge.

Round and flat run of the reduced diameter end

Customers can request a trial to accomplish these values as shown. Values xxx < 0.02 upon request.

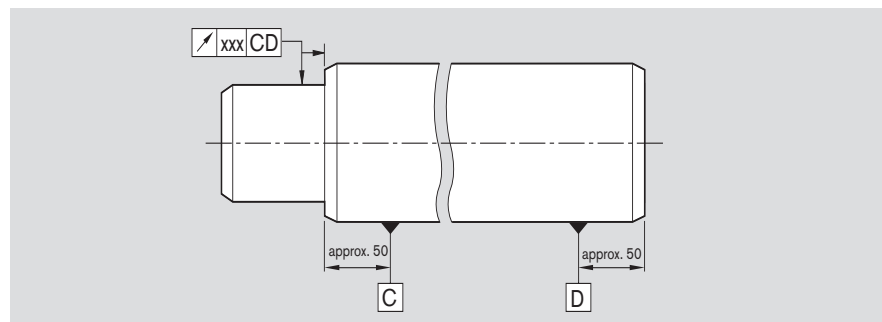

Precision steel shafts

Shaft Machining

Advantages

- Many processing options
- Shorter delivery times
- Lower cost

Shafts with radial holes, drilled or drilled and tapped

Shafts that have to be supported require radial holes for attachment of the shaft supports. The radial holes are drilled into the steel shafts after hardening and grinding. The diameter, depth and spacing of the holes depend on the diameter of the shaft. Refer to the table in the sections "Shaft Support Rails for Standard and Super Linear Bushings" and "Shaft Support Rails for Radial Linear Bushings" for standard dimensions.

Ordering

- Inquiries with customer design or template
- Registered dimensions and tolerances
- Avoid oversizing
- Machining on one or both sides

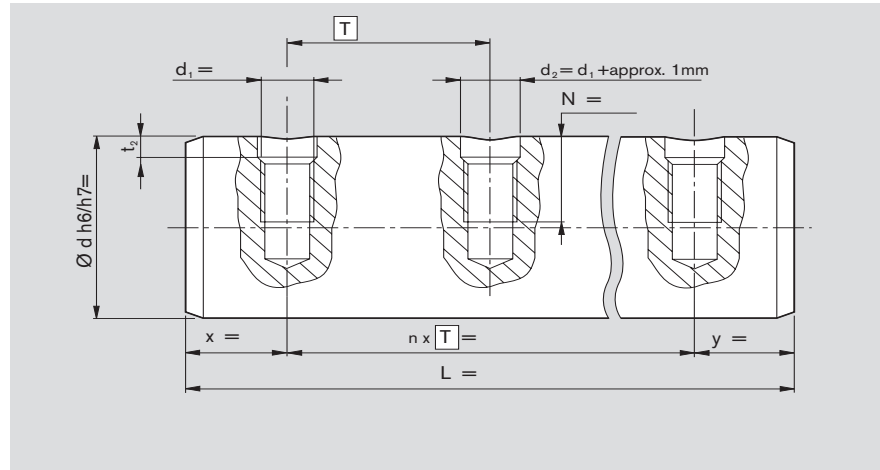

Recommended values for boring of clearing holes in the hardened surface zone

Dimensions [mm]		
Ø d	d ₁	t ₂
12	M4	2.5
16	M5	2.5
20	M6	3.0
25	M8	3.0
30	M10	3.5
40	M10	4.0
40	M12	4.5

Dimensions [mm]		
Ø d	d ₁	t ₂
50	M12	4.0
50	M14	4.5
50	M16	5.0
60	M14	5.5
60	M20	6.5
80	M16	5.5
80	M24	6.5

Values for corrosion-resistant steel shafts upon request.

For matching Shaft Support Rails, see the related chapter.

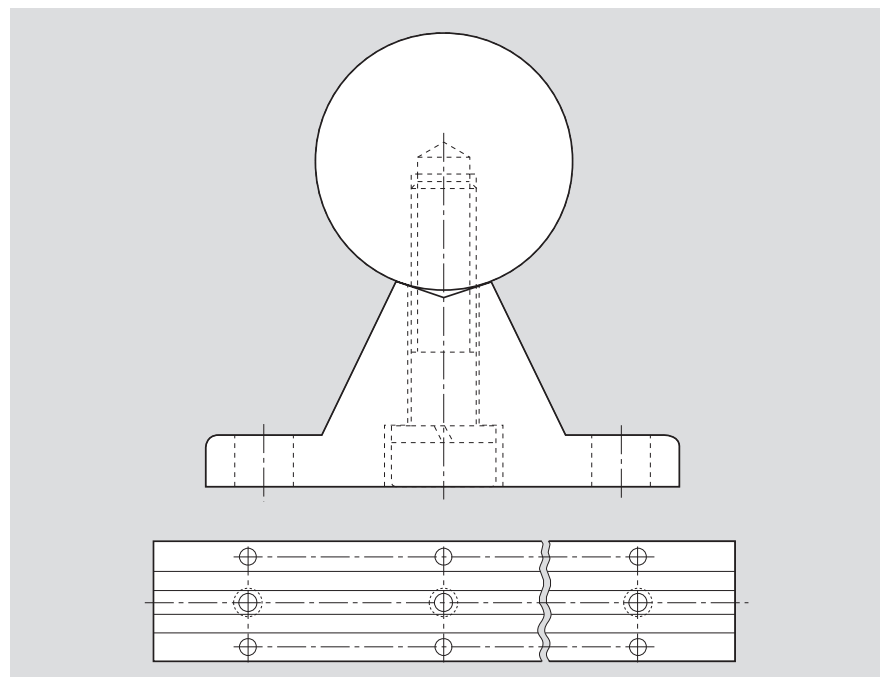

Shaft ends with tapped hole

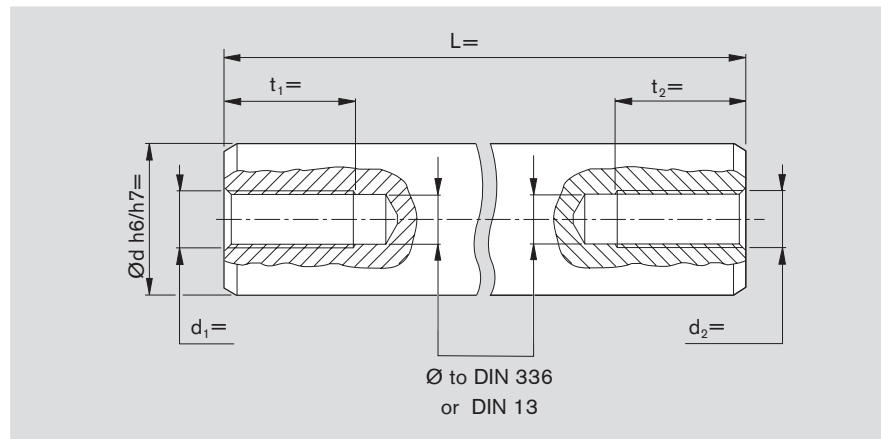

Shaft ends with tapped hole and centering bore to DIN 332-D

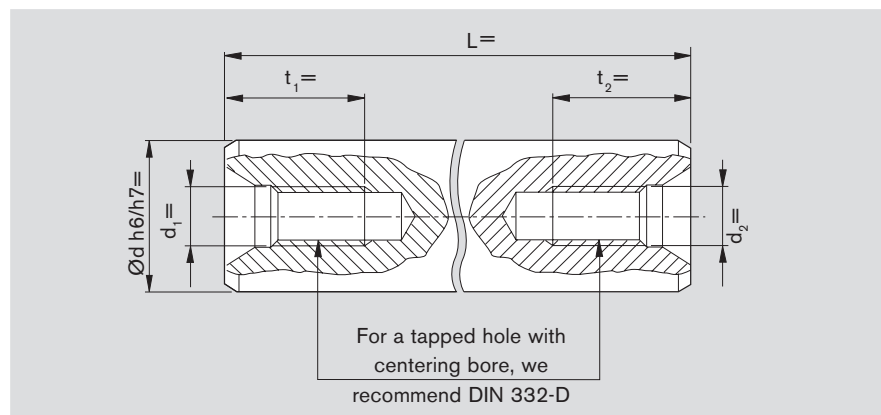

Recommended dimension for shaft ends with tapped hole and centering bore.

Shaft $\varnothing d$ [mm]	Thread d_1/d_2	Depth t_1/t_2 [mm]
8	M4	10
10	M4	10
12	M5	12.5
14	M5	12.5
16	M6	16
20	M8	19
25	M10	22
30	M12	28
40	M12	28
50	M16	36
60	M20	42
80	M24	50



Precision steel shafts

Shaft Machining

Shaft ends for retaining ring groove to DIN 471

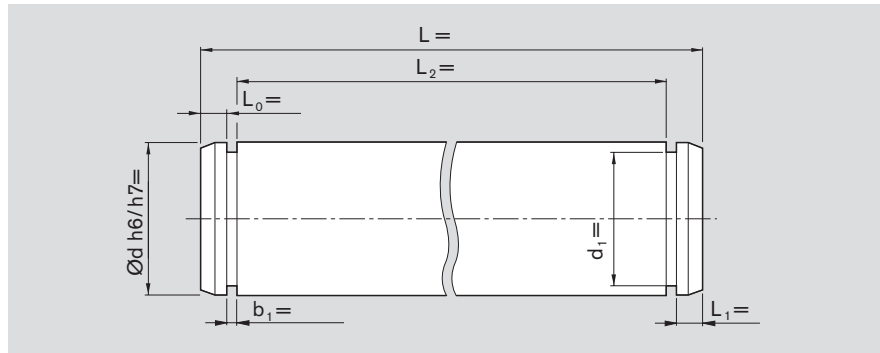

Shaft ends with 90° cutout

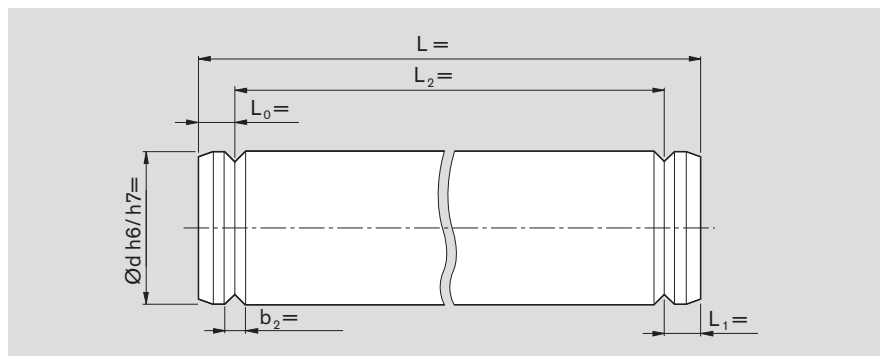

Shaft ends with 90° countersink

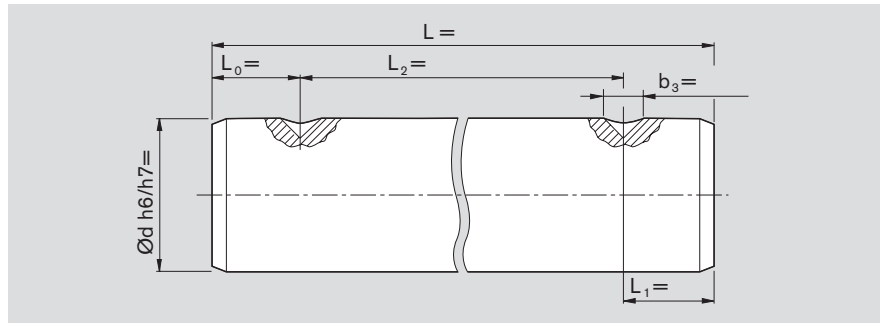

Dimensional recommendation for shaft ends for retaining ring, 90° shaft ends, 90° countersink:

Ød	Dimension [mm]				Retaining ring DIN 471-	
	b ₁ +0.1	d ₁	b ₂	b ₃	Dimension [mm]	Part number
4	0.5	3.8 -0.04	-	-	4x0.4	R3410 765 00
5	0.7	4.8 -0.04	2	3	5x0.6	R3410 742 00
8	0.9	7.6 -0.06	2	4	8x0.8	R3410 737 00
10	1.1	9.6 -0.11	2	5	10x1	R3410 745 00
12	1.1	11.5 -0.11	2.5	5	12x1	R3410 712 00
14	1.1	13.4 -0.11	2.5	5	14x1	R3410 747 00
16	1.1	15.2 -0.11	3	5	16x1	R3410 713 00
20	1.3	19 -0.13	3	5	20x1.2	R3410 735 00
25	1.3	23.9 -0.21	4	6	25x1.2	R3410 750 00
30	1.6	28.6 -0.21	4	6	30x1.5	R3410 724 00
40	1.85	37.5 -0.25	5	8	40x1.75	R3410 726 00
50	2.15	47 -0.25	5	8	50x2	R3410 727 00
60	2.15	57 -0.3	6	8	60x2	R3410 764 00
80	2.65	76.5 -0.3	6	10	80x2.5	-

Shaft ends with spigot both ends

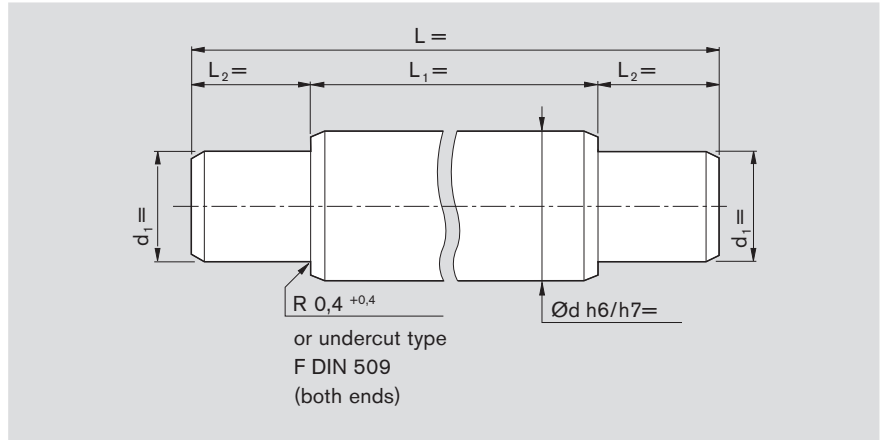

Shaft ends with threaded spigot (both ends)

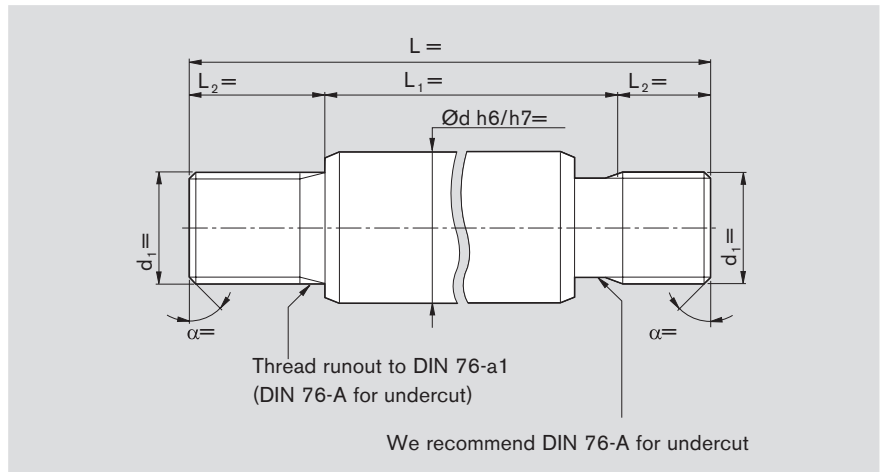

Shaft ends with spigot and threaded spigot (both ends)

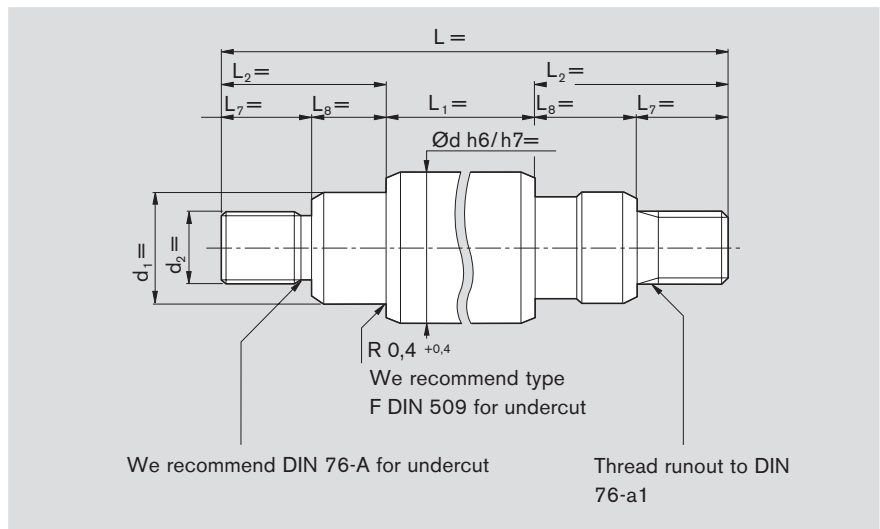

Precision steel shafts

Shaft Machining

Shaft ends with single flat (both ends)

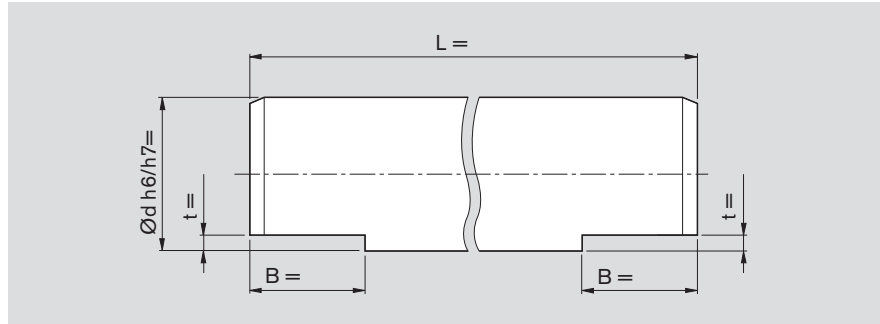

Shaft ends with outer flats (one end)

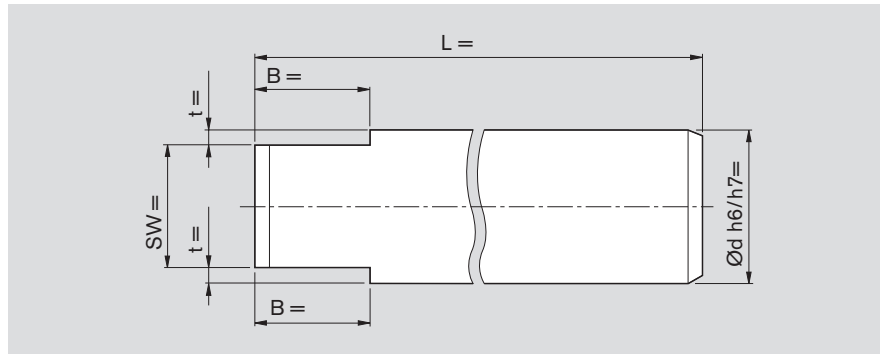

Shaft ends with grooves (both ends)

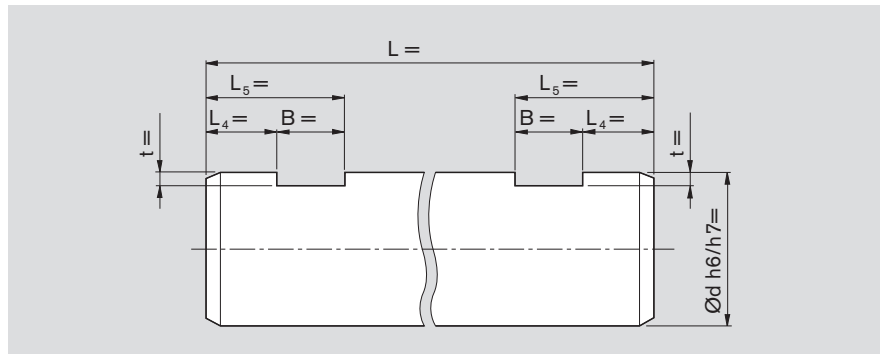

Shaft ends with inner flats (one end)

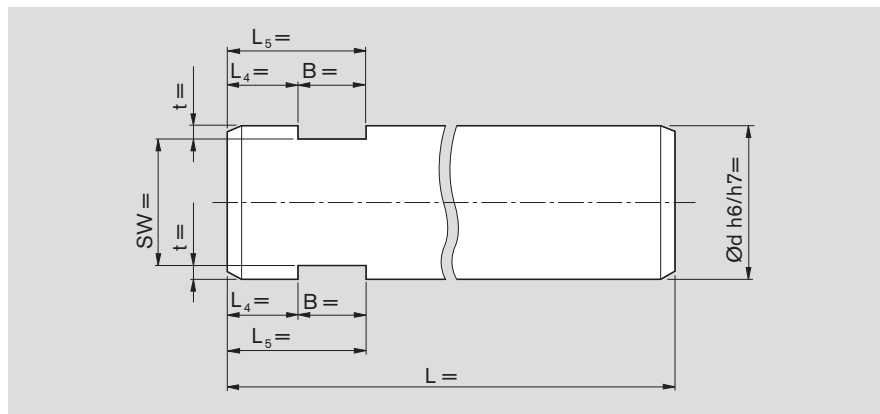

Spring groove to DIN 6885-1

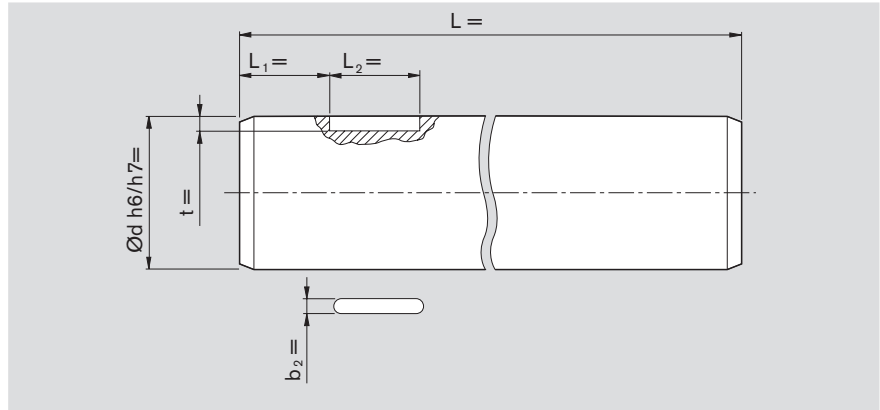

Dimensional recommendation:

Ød	Dimensions [mm]	
	b ₂ P9	t
8	2	1.2 +0.1
10	3	1.8 +0.1
12	4	2.5 +0.1
14	5	3 +0.1
16	5	3 +0.1
20	6	3.5 +0.1
25	8	4 +0.2
30	8	4 +0.2
40	12	5 +0.2
50	14	5.5 +0.2
60	18	7 +0.2
80	22	9 +0.2

Shaft ends with holes tapped to pitch circle (both ends)

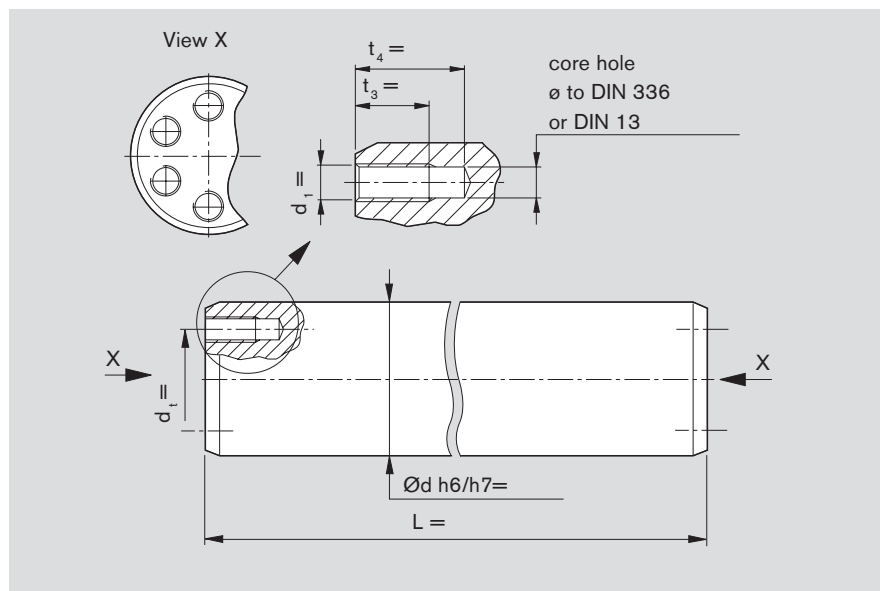

Precision steel shafts

Ordering data

Solid shafts made of heat-treated steel

When a shaft forms an integral part of an anti-friction bearing system, the materials used have to satisfy exacting requirements.

Rexroth offers the optimum shaft material for each diameter range. The materials we use have a much higher carbon content compared to frequently used mass-produced steels, which has a very positive influence on the achievable surface hardness and provides better resistance to aging.

The exceptionally uniform surface hardness and hardening depth of Rexroth shafts, combined with an excellent degree of purity, homogeneous microstructure and defined grain sizes, ensure particularly long service life under rolling loads.

Available diameters [mm]
3, 4, 5, 6, 8, 10, 12, 14, 15, 16, 18, 20, 22, 24, 25, 30, 32, 35, 38, 40, 45, 50, 55, 60, 70, 80, 100, 110

Ø d [mm]	Lengths [m]
3	0.4
4 - 8	3.6
10 - 110	6.1

Solid shafts from 20 mm in diameter and up to 8 m in length are available upon request. Greater overall lengths are composed of sections joined end-to-end. Linear Bushing can roll over joints without any problems.

Materials	Hardness
Cf 53, Cf 60, Ck 67	min. 60 HRC

Part numbers	
Tolerance h6	R1000 xxx 00
Tolerance h7	R1000 xxx 01

xxx = Diameter in mm

Ordering example:

Solid Shaft Ø 25 h7 out of heat-treated steel.

Length: 460 mm

Part number:

R1000 025 01, 460 mm

Corrosion-resistant solid steel shafts to ISO 683-17 / EN 10088

The correct choice for applications requiring high corrosion resistance in a clean environment, e.g. in the food industry, semiconductor manufacturing and medical engineering.

X 90 CrMoV 18 differs from X 46 Cr 13 in that it is additionally resistant to lactic acid.

Materials	Available diameters [mm]
X 46 Cr 13	4, 5, 6, 8, 10, 12, 14, 16, 20, 25, 30, 40, 50, 60, 80
X 90 CrMoV 18	3, 12, 16, 20, 25, 30, 40, 50, 60, 80

Ø d [mm]	Lengths [m]
3	0.4
4-10	3.6
12-80	6.1

Greater overall lengths are composed of sections joined end-to-end. Linear Bushing can roll over joints without any problems.

Materials	Hardness
X 46 Cr 13	min. 54 HRC
X 90 CrMoV 18	min. 55 HRC

Part numbers X 46 Cr 13	
Tolerance h6	R1000 0xx 30
Tolerance h7	R1000 0xx 31

Part numbers X 90 CrMoV 18	
Tolerance h6	R1000 0xx 20
Tolerance h7	R1000 0xx 21

xx = Diameter in mm

Ordering example:

Solid shaft Ø 16 h6 out of corrosion-resistant steel X 46 Cr 13.

Length: 350 mm

Part number:

R1000 016 30, 350 mm

Solid steel shafts with hard-chromium plating

Optimum anti-corrosion protection for applications in chemically aggressive environments.

Available diameter [mm]	
12, 16, 20, 25, 30, 40, 50, 60, 80	

Ø d [mm]	Lengths [m]
12	5.5
16, 20	6.5
25 - 80	7

Greater overall lengths are composed of sections joined end-to-end. Rexroth Linear Bushings can roll over joints without any problems.

Materials	Hardness
Cf 53, Cf 60, Ck 67	min. 60 HRC (approx. 700 HV)
Chrome plating (Thickness approx. 10 µm)	approx. 1000 HV

Part numbers	
Tolerance h6	R1000 0xx 60
Tolerance h7	R1000 0xx 61

xx = Diameter in mm

Ordering example:
Solidshaft Ø 30
Hard chromium plating h7,
Length 480 mm
Part number:
R1000 030 61, 480 mm

Heat-treated tubular steel shafts

Tubular shafts are conductive and can transport liquids and gasses. Tubular shafts are also often used for weight reduction. The material is smoothly rolled. The interior diameters are rough.

Available diameter [mm]	
outer	inner (approx.)
8	3
10	4
12	3.4
16	8
20	14
25	14
30	19
40	26.5
50	29.6
60	36.5
80	57.4
100	65

Ø d [mm]	Lengths max. [m]
8, 10	1
16	2
20	5.7
12 and 25 - 100	6.1

Materials	Hardness
Ck 60	min. 60 HRC

Part numbers	
Tolerance h6	R1001 xxx 10
Tolerance h7	R1001 xxx 11

xxx = Outer diameter in mm

Ordering example:
Tubular shaft Ø 80 h7.
Length 3600 mm
Part number:
R1001 080 11. 3600 mm

Tubular shafts, hard chromium plating

The outer diameter of tubular shafts are hard-chromium plated.

Available diameter [mm]	
outer	inner
25	14
30	19
40	26.5
50	29.6
60	36.5
80	57.4

Length : max 6.1 m

Materials	Hardness
Ck 60	min. 60 HRC (approx. 700 HV)
Chrome plating (Thickness approx. 10 µm)	approx. 1000 HV

Part numbers	
Tolerance h7	R1001 0xx 41

xx = Outer diameter mm

Ordering example:
Tubular shaft Ø 40. Hard chromium plating h7. Length 2000 mm
Part number:
R1001 040 41, 2000 mm



Steel shafts with ready-mounted shaft supports, Shaft supports

The Advantages

- For long guides or high loads that do not permit the use of a free-standing shaft due to shaft deflection
- Unlimited length possible using shafts with socket connections
- Suitable supports for different Linear Bushing types and operating requirements
- Increased degree of freedom in circumferential direction compared to profiled guide rails
- For applications where linear guides would be subjected to tensional forces caused by inaccurate sub-structures

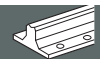

Shaft support rails with ready-mounted steel shafts

Selection guide

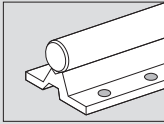
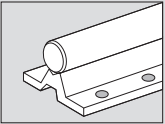
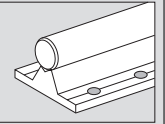
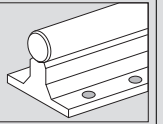
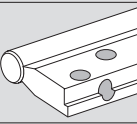
	R1010	R1025	R1014	R1011	R1015
					
Frequency of use	+++	+++	+++	+++	++
Low cost	+++	+++	++	++	++
For super and standard Linear Bushings	+++	+++	+++	+++	+++
High precision	++	++	+++	+++	+++
For high loads	++	++	+++	+++	+++
Flanged small height	+++	+++	+++	o	o
Flanged large height	o	o	o	+++	o
Flangeless underside attachment	o	o	o	o	o
For side mounting	o	o	o	o	+++
For Aluminum extrusion	o	+++	o	o	o
Aluminum shaft support	+++	+++	+++	+++	+++
Steel shaft support	o	o	o	o	o
With corrosion-resistant shaft ¹⁾	+++	+++	+++	+++	+++

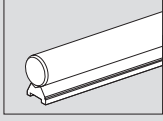
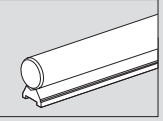
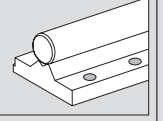
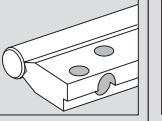
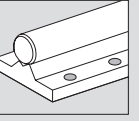
	R1013	R1016	R1018	R1020	R1012
					
Frequency of use	++	++	+	+	+
Low cost	+++	++	+	+	+
For super and standard Linear Bushings	+++	+++	o	o	o
High precision	++	+++	+++	+++	+++
For high loads	+++	+++	+++	+++	+++
Flanged small height	o	o	++	o	+++
Flanged large height	o	o	o	o	o
Flangeless underside attachment	+++	+++	o	o	o
For side mounting	o	o	o	+++	o
For Aluminum extrusion	o	o	o	o	o
Aluminum shaft support	+++	o	o	o	o
Steel shaft support	o	+++	+++	+++	+++
With corrosion-resistant shaft ¹⁾	+++	+++	+++	+++	+++

¹⁾ Available corrosion protection: Hard-chromium plated shaft
Material X46Cr13
Material X90CrMoV18

+++ Extremely well suited
++ Well suited
+ Suited
o Not recommended



Shaft support rails with ready-mounted steel shafts

1. General

The individual support rails are arranged end to end underneath the corresponding shafts. Once the elements have been aligned and the linear motion assemblies screwed down onto a torsionally stiff, surface-machined base, the units will reflect the tolerances as given in the tables.

2. Part numbers

2.1 For use with open-type Standard and Super Linear Bushings

R1010 Precision steel shaft with flanged aluminum shaft support rail, low profile version, greater height tolerance, very economically priced

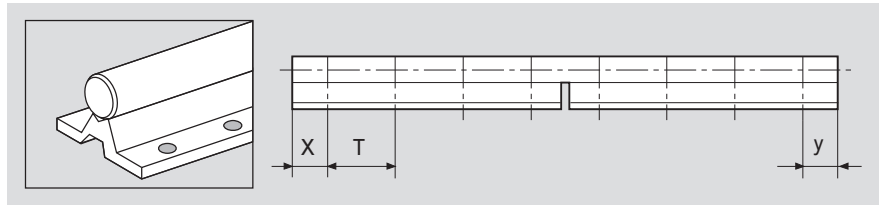

R1025 same as R1010 but with drilling distance for aluminum framing

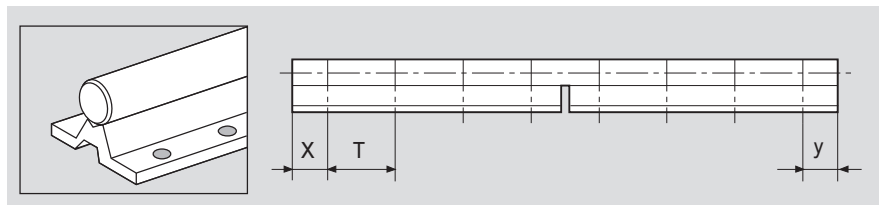

R1014 Precision steel shaft with flanged aluminum shaft support rail, low-profile version

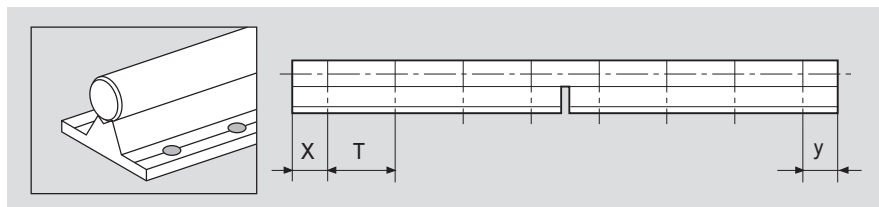

R1011 Precision steel shaft with flanged aluminum shaft support rail, high-profile version

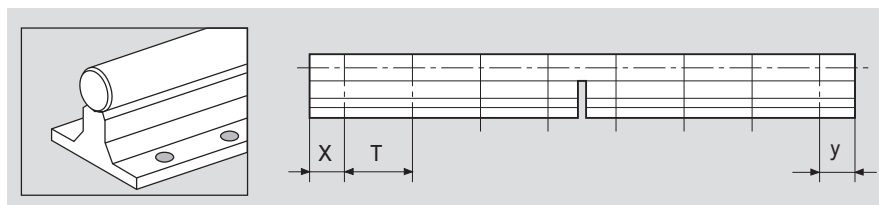

R1015 Precision steel shaft with aluminum shaft support rail, for side mounting

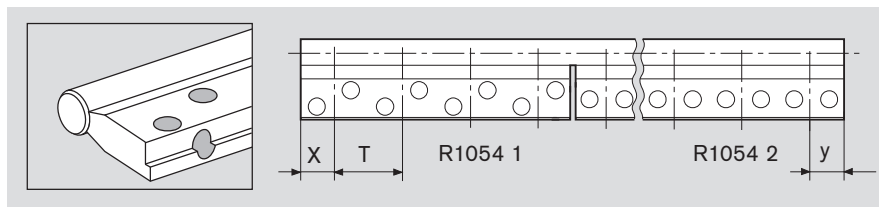

R1013 Precision steel shaft with flangeless aluminum shaft support rail, greater height tolerance (only available ready-mounted)

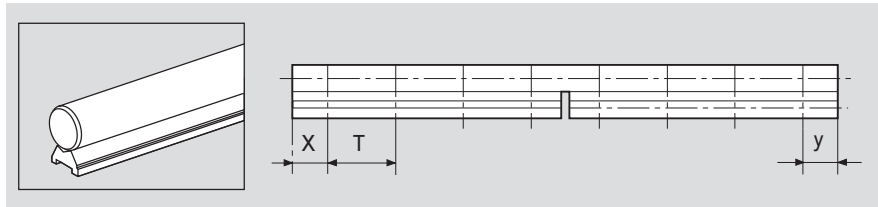

R1016 Precision steel shaft with flangeless steel shaft support rail (only available ready-mounted)

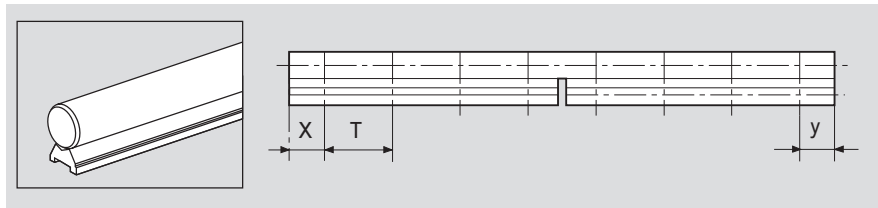

2.2 For use with Radial Linear Bushings

R1018 Precision steel shaft with flanged steel shaft support rail

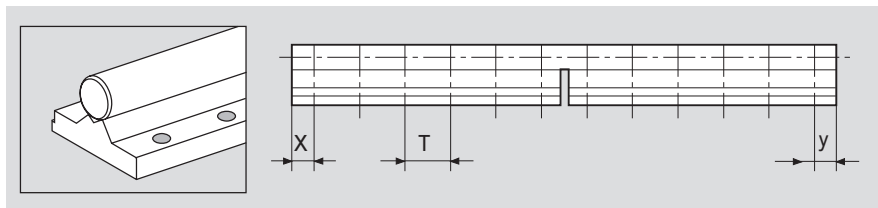

R1020 Precision steel shaft with steel shaft support rail, for side mounting

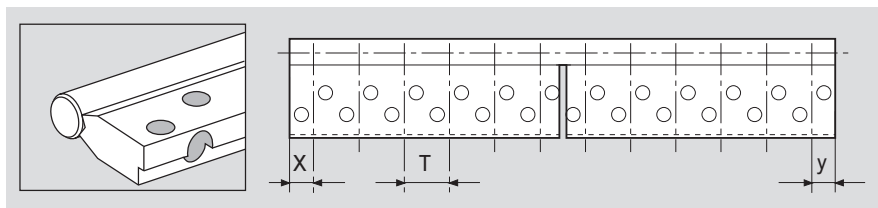

2.3 For use with Radial Compact Sets

R1012 Precision steel shaft with special flanged steel shaft support rail for Radial Compact Sets (only available ready-mounted)

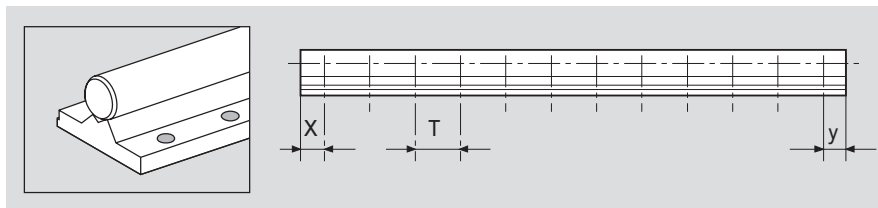

Shaft support rails with ready-mounted steel shafts

Assembly, Ordering data, Mounting

End spaces x and y

If the ordered shaft length is a whole multiple of the hole spacing dimension in a shaft support rail, the spaces at the ends of the rail will be half the pitch length (x and $y = T/2$). For other shaft lengths we make sure the holes are centered over the length ($x = y$). This is done by cutting off material at both ends of any overhanging shaft support rail. The end spaces x and y should not measure less than $0.2 \times T$.

If the customer has not supplied a drawing, our proposal and order confirmation will include the hole spacing we have determined for the steel shaft. This then gives the necessary location of the mounting holes in the machine bed. We recommend comparing this data with the machine design documents.

Ordering data: Part number R10.. / Length ... mm / x ... mm / y ... mm

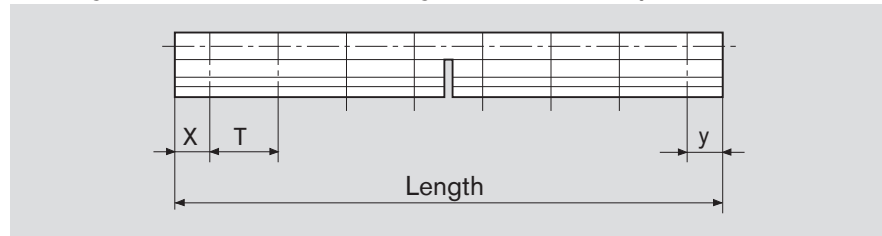

Extra-long and composite linear motion assemblies

A shaft section with mounted shaft support rail should not exceed 6 meters in length. Longer assemblies are composed of a number of sections fitted end to end by plug-type mounting. If the shaft sections are to be screwed together, the shaft support rails will have to be mounted at the customer's facility (see also section on "Composite Shafts").

The arrangement of joints in the shaft and the shaft support rail depends on the type of assembly. Basically, however, the joint in the shaft and the joint in shaft support rail must always be staggered.

Special bore distances

Shafts with ready-mounted shaft supports can also be custom ordered with special bore distances.

Mounting note for flangeless shaft support rails

To facilitate mounting and in applications subject to major side loads, we recommend retention by means of a flat retaining strip or a wedge-profile as shown in the illustration below.

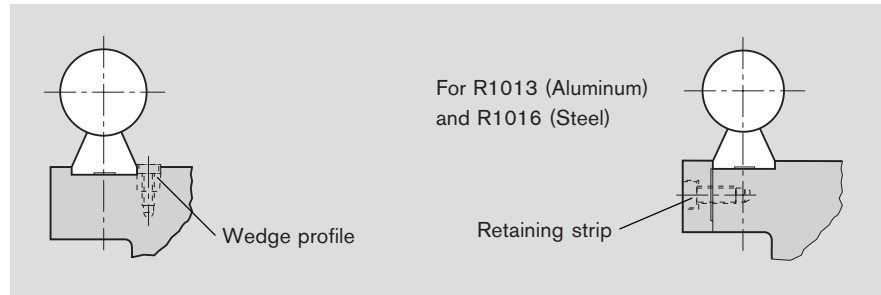

The shaft support rail must be carefully aligned for mounting as follows: push the first shaft and shaft support rail up against the fitting edge and screw down; then align the second shaft, preferably with the aid of a straightedge, and screw down.

These elements are supplied only together with Precision Steel Shafts. The maximum length of a support rail is 3000 mm; if longer lengths are required, the rails can be mounted end to end. The fitting edge allows easy alignment of the shaft support rails, thus avoiding any stressing of the linear bushings.

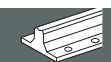
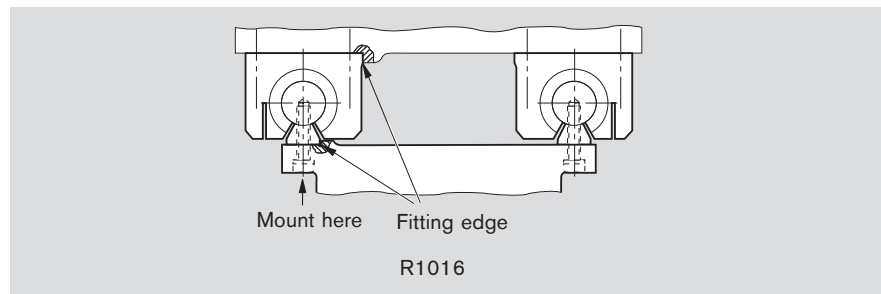

Shaft support rails with ready-mounted steel shafts for open standard and super Linear Bushings

Flanged, low profile version

R1010 Steel shaft ready-mounted with shaft supports

Material

- Shaft support: Aluminum

Structural Design

- Low overall height
Used in conjunction with Linear sets, these shaft support rails make it possible to build linear motion guideways with an extremely low overall height.
- High rigidity
The shaft bearing surface of the support rail is matched to the diameter of the mating-size shaft to ensure that the shaft bearing pressure acts at the optimum angle; together with the sturdy mounting screws, this guarantees high rigidity.
- Cost-effective use
Greater height tolerances permit easy and cost-effective assembly of supported guideways.

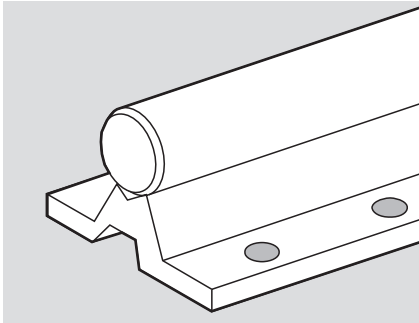

Shaft Ø d [mm]	Part numbers		Mass [kg/m]
	Drilling hole distance T ₁	Drilling hole distance T ₂	
16	R1010 016 ..	R1010 516 ..	2.5
20	R1010 020 ..	R1010 520 ..	3.8
25	R1010 025 ..	R1010 525 ..	5.4
30	R1010 030 ..	R1010 530 ..	7.6
40	R1010 040 ..	R1010 540 ..	12.6

- 00 = shaft out of heat-treatable steel, h6
- 01 = shaft out of heat-treatable steel, h7
- 30 = shaft out of corrosion-resistant steel, h6
- 31 = shaft out of corrosion-resistant steel, h7
- 60 = Shafts out of hard-chromium plating out of corrosion-resistant steel, h6
- 61 = Shafts out of hard-chromium plating out of corrosion-resistant steel, h7

Ordering example

For a shaft support rail with a shaft of hea-treatable steel (T₁), 30 mm diameter, 900 mm length, tolerance quality h7:

R1010 030 01 / 900 mm.

Dimension

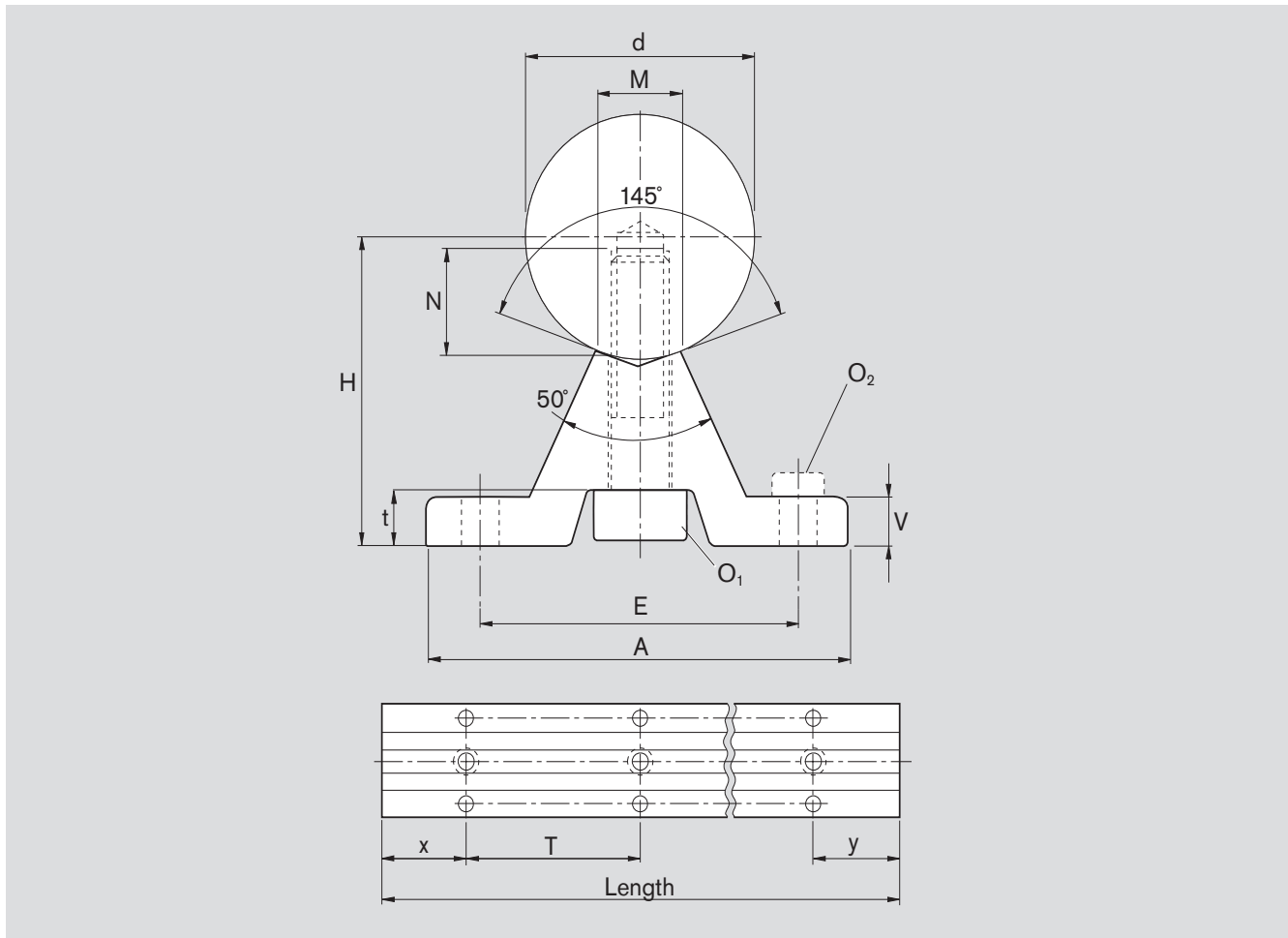

$\varnothing d$	$H^{1)}$ ± 0.1	A	V	M	Dimensions [mm]					Drill hole distances ³⁾	
					O_1 DIN6912-8.8	N	E	t	$O_2^{2)}$ DIN6912-8.8	T_1	T_2
16	26	45	5	7	M5x20	9	33	6	M5x16	100	150
20	32	52	6	8.3	M6x25	11	37	7	M6x16	100	150
25	36	57	6	10.8	M8x30	15	42	7	M6x16	120	200
30	42	69	7	11	M10x35	17	51	7.5	M8x25	150	200
40	50	73	8	15	M10x40	19	55	7	M8x25	200	300

¹⁾ Measured with gauging shaft of nominal diameter d and length approx. 50 mm. Lengths up to 3000 mm with a parallelism of 0.1 mm on request.

²⁾ Applies only to fixing in tapped holes in steel or cast iron.

³⁾ T_1 : Traverse load of the Linear Bushing opening and approximate utilization of the load capacities.

T_2 : For general requirements

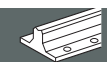

Shaft support rails with ready-mounted steel shafts for open standard and super Linear Bushings

For Aluminum Structural Framing

R1025 Shaft support rails with precision steel shaft ¹⁾

Material

- Support rail: Aluminum

Advantages

- Fast and easy, modular assembly of linear bushings and shafts on aluminum profile systems
- Very cost effective due to restricted height tolerance.

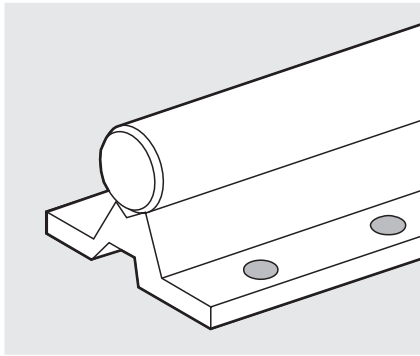
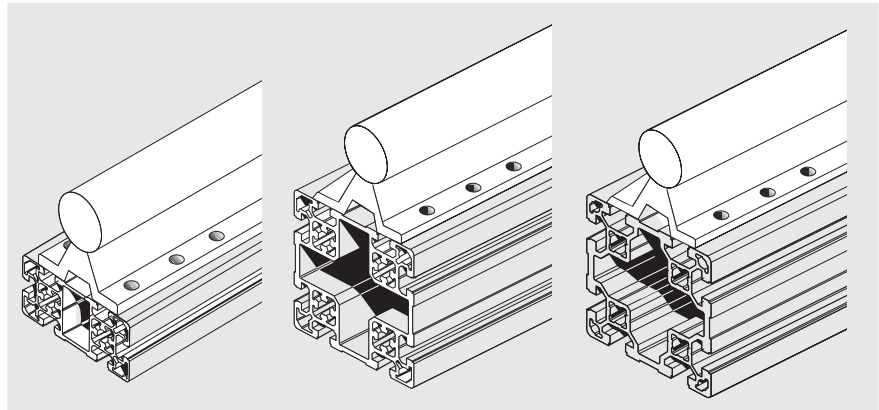

Shaft Ø d [mm]	Mass with shaft E [mm]	Part numbers	Mass [kg/m]
25	40	R1025 025 ..	5.4
30	45	R1025 530 ..	7.5
30	50	R1025 030 ..	7.5

Shafts:

- 00 = shaft of heat-treatable steel, h6
- 01 = shaft of heat-treatable steel, h7
- 30 = shaft of corrosion-resistant steel, h6
- 31 = shaft of corrosion-resistant steel, h7
- 60 = hard chromium plating out of heat-treatable steel, h6
- 61 = hard chromium plating out of heat-treatable steel, h7

R1039 Support rails with drilled holes

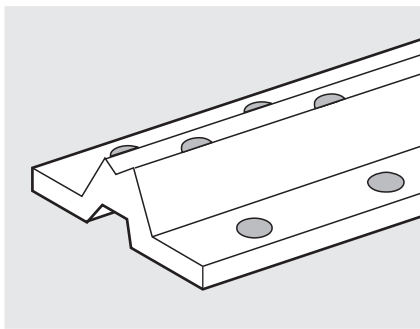

Shaft Ø d [mm]	Mass with shaft E [mm]	Part numbers	Mass [kg/m]	Length [mm]
				-0.5
				-1.5
25	40	R1039 825 00	1.6	2880
30	45	R1039 930 00	2.0	2880
30	50	R1039 830 00	2.0	2880

R1039 Support rails without drilled holes

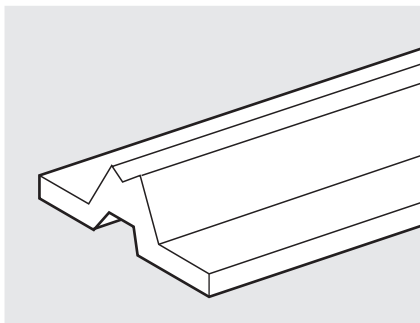

Shaft Ø d [mm]	Part numbers	Mass [kg/m]	Length [mm]
			-0.5
			-1.5
25	R1039 525 00	1.6	3000
30	R1039 530 00	2.0	3000

¹⁾ Ordering example:

For a shaft support rail with a shaft of heat-treatable steel, 25 mm diameter, 900 mm length, tolerance quality h7:
R1025 025 01 / 900 mm.

Dimensions

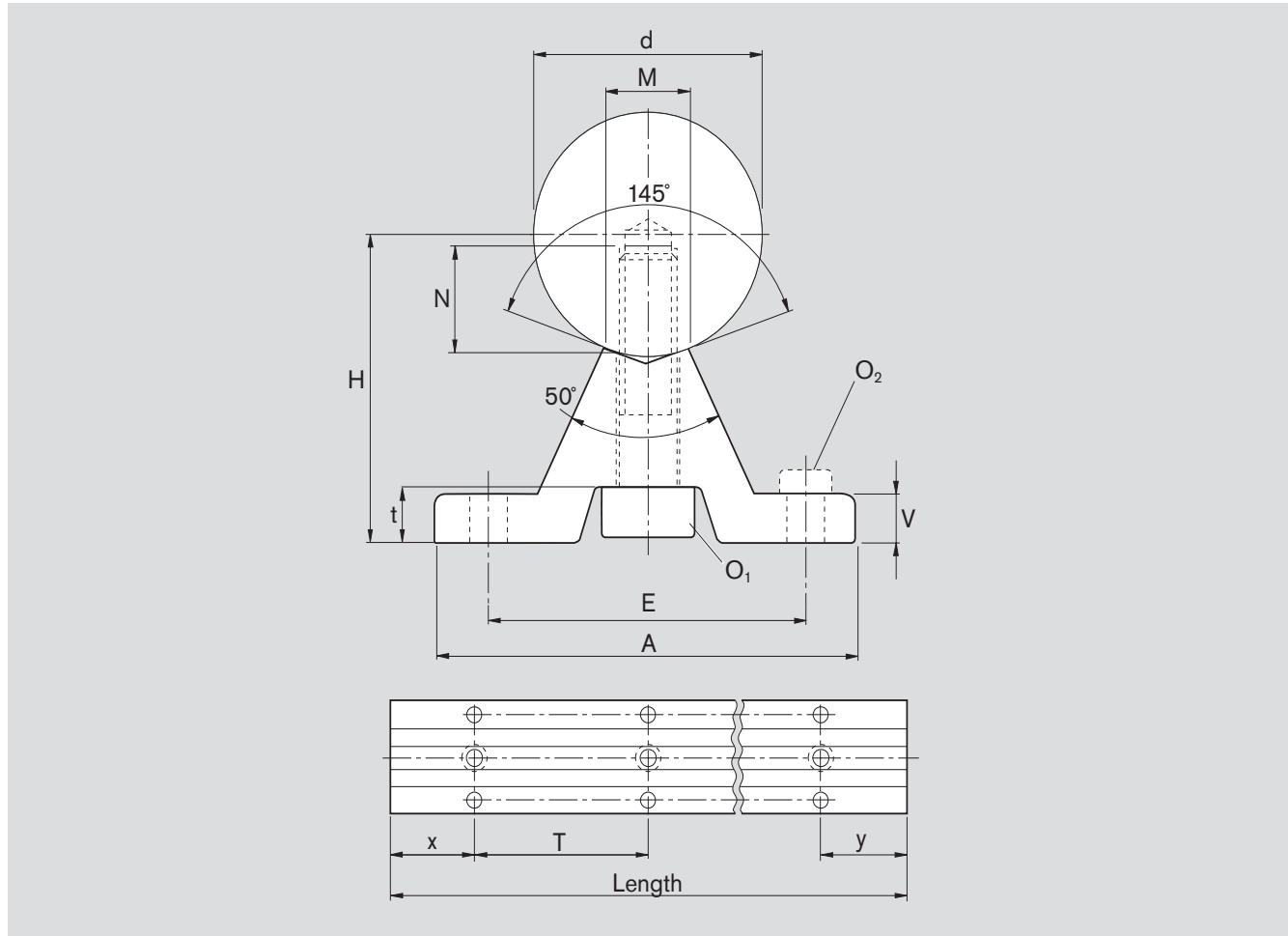

$\varnothing d$	$H^{1)}$ $\pm 0,1$	Dimensions [mm]									
		A	V	M	O_1 DIN6912-8.8	N	E	t	O_2 DIN6912-8.8	T	
25	36	57	6	10.8	M8x30	15	40	7	M6	180	
30	42	69	7	11	M10x35	17	45	7.5	M8	180	
30	42	69	7	11	M10x35	17	50	7.5	M8	180	

¹⁾ Measured with gauging shaft of nominal diameter d and length approx. 50 mm. Lengths up to 3000 mm with a parallelism of 0.1 mm on request.

For profiled systems, see the catalog "Aluminum Structural Framing".

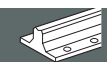
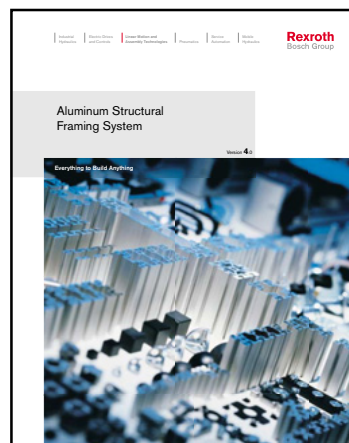

Shaft support rails with ready-mounted steel shafts for open standard and super Linear Bushings

Flanged, low profile version

R1014 Steel shaft ready-mounted with shaft supports

Material

- Shaft support: Aluminum

Structural Design

- Low overall height
Used in conjunction with Linear sets, these shaft support rails make it possible to build linear motion guideways with an extremely low overall height.
- High rigidity

The shaft bearing surface of the support rail is matched to the diameter of the mating-size shaft to ensure that the shaft bearing pressure acts at the optimum angle; together with the sturdy mounting screws, this guarantees high rigidity.

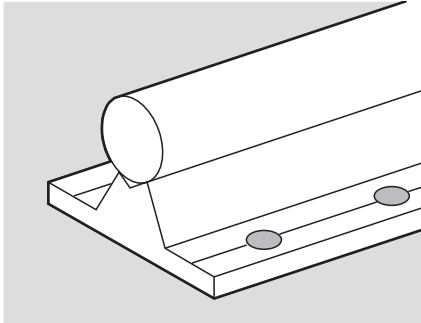

Shaft Ø d [mm]	Part numbers		Mass [kg/m]
	Drilling hole distance T ₁	Drilling hole distance T ₂	
12	R1014 012 ..	R1014 512 ..	1.75
16	R1014 012 ..	R1014 516 ..	2.65
20	R1014 020 ..	R1014 520 ..	3.95
25	R1014 025 ..	R1014 525 ..	5.6
30	R1014 030 ..	R1014 530 ..	7.9
40	R1014 040 ..	R1014 540 ..	12.8
50	R1014 050 ..	R1014 550 ..	19.4
60	R1014 060 ..	-	27.3
80	R1014 080 ..	-	47.3

- 00 = shaft out of heat-treatable steel, h6
- 01 = shaft out of heat-treatable steel, h7
- 30 = shaft out of corrosion-resistant steel, h6
- 31 = shaft out of corrosion-resistant steel, h7
- 60 = Shafts out of hard-chromium plating out of corrosion-resistant steel, h6
- 61 = Shafts out of hard-chromium plating out of corrosion-resistant steel, h7

R1050 Support Rail with drilled holes, length [mm] 600^{-0.5}_{-1.5}

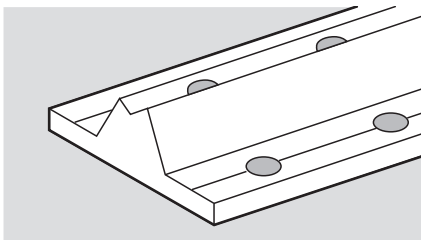

Shaft Ø d [mm]	Part numbers			Mass [kg]
	Drilling hole distance T ₁	Drilling hole distance T ₂	not drilled	
12	R1050 612 00	R1050 712 00	R1050 512 00	0.52
16	R1050 616 00	R1050 716 00	R1050 516 00	0.64
20	R1050 620 00	R1050 720 00	R1050 520 00	0.90
25	R1050 625 00	R1050 725 00	R1050 525 00	1.08
30	R1050 630 00	R1050 730 00	R1050 530 00	1.43
40	R1050 640 00	R1050 740 00	R1050 540 00	1.81
50	R1050 650 00	R1050 750 00	R1050 550 00	2.45
60	R1050 660 00	-	R1050 560 00	3.16
80	R1050 680 00	-	R1050 580 00	4.86

R1050 Support Rail without drilled holes, length, [mm] 600^{-0.5}_{-1.5}

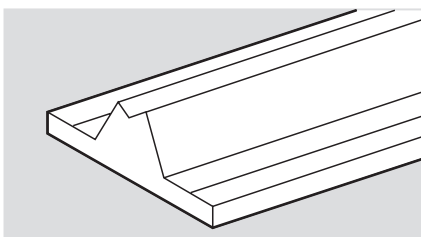

Ordering example

For a shaft support rail with a shaft of heat-treatable steel, 30 mm diameter, 1200 mm length, tolerance quality h6, mounted with shaft support R1050 030 60:

R1014 030 00 / 1200 mm.

Dimensions

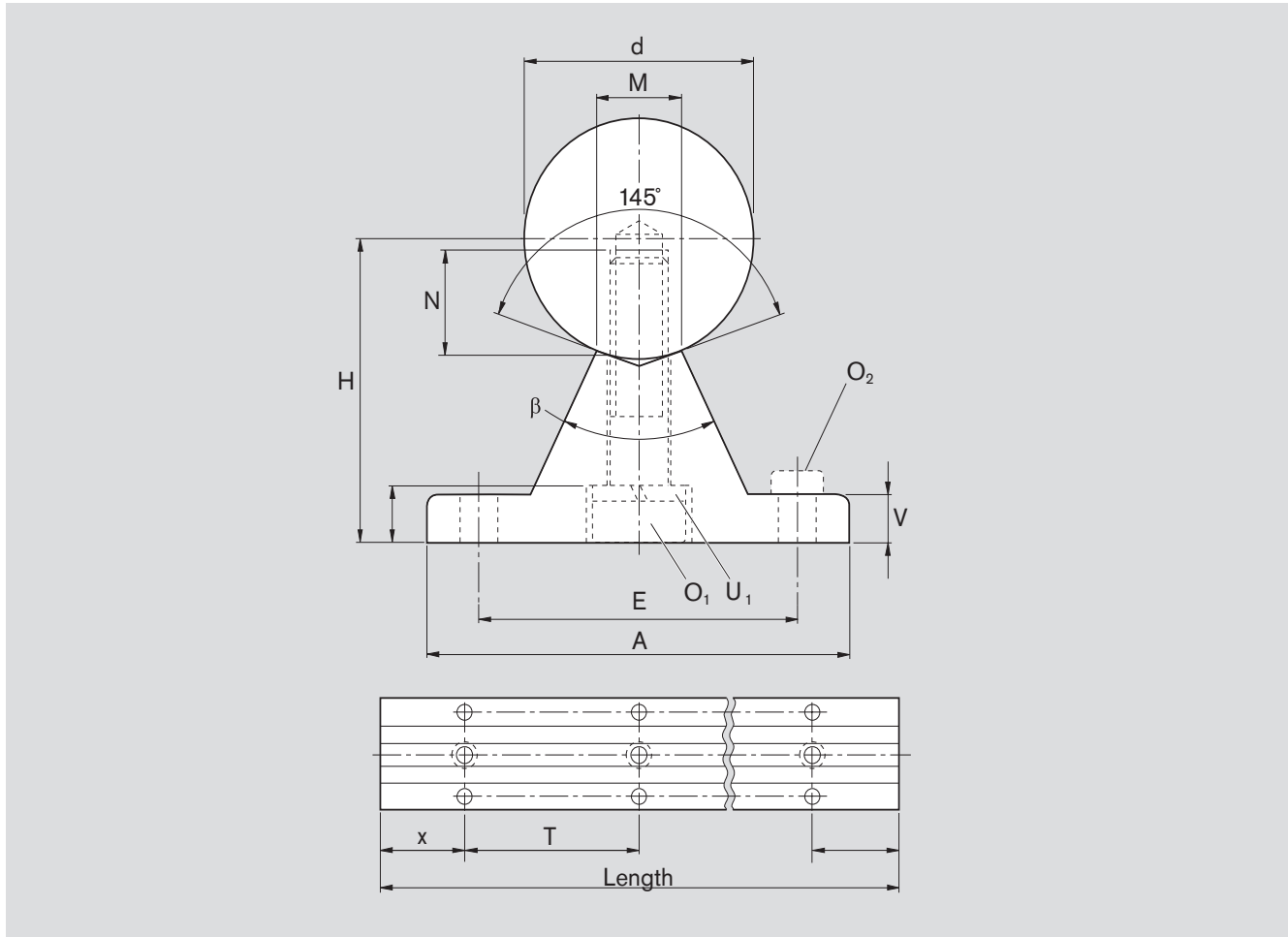

$\varnothing d$	$H^{1)}$ ± 0.01	A	V	M	Dimensions [mm]							Drill hole distances ⁴⁾		Angle β [°]
					O_1 DIN6912-8.8	U_1 DIN7980 ²⁾	N	E	t	$O_2^{3)}$ DIN6912-8.8	T_1	T_2		
12	22	40	5	5.8	M4x20	4	8	29	4.5	M4x12	75	120	50	
16	26	45	5	7	M5x20	5	9	33	7.6	M5x16	100	150	50	
20	32	52	6	8.3	M6x25	6	11	37	8.6	M6x16	100	150	50	
25	36	57	6	10.8	M8x30	8	15	42	9	M6x16	120	200	50	
30	42	69	7	11	M10x35	10	17	51	10	M8x25	150	200	50	
40	50	73	8	15	M10x40	10	19	55	9.5	M8x25	200	300	50	
50	60	84	9	19	M12x45	12	21	63	11.5	M10x30	200	300	46	
60	68	94	10	25	M14x50	14	25	72	13	M10x30	300	-	46	
80	86	116	12	34	M16x60	16	28	92	15	M12x35	300	-	46	

Applications that require very high stiffness and dimensional precision, the drill hole distances for the middle holes (shaft mounting) $0.5 T_1$ should be implemented.

¹⁾ Measured with gauging shaft of nominal diameter d and length approx. 50 mm.

²⁾ DIN 7980 withdrawn. The washer, however, is still available.

³⁾ Applies only to fixing in tapped holes in steel or cast iron.

⁴⁾ T_1 : Traverse load of the Linear Bushing opening and approximate utilization of the load capacities.

T_2 : For general requirements

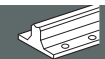

Shaft support rails with ready-mounted steel shafts for open standard and super Linear Bushings

Flanged, high profile version

R1011 Steel shaft ready-mounted with shaft supports

Material

- Shaft support: Aluminum

Structural Design

- the overall shaft height combined with linear sets allows a large fitting space for drive, control and measuring components

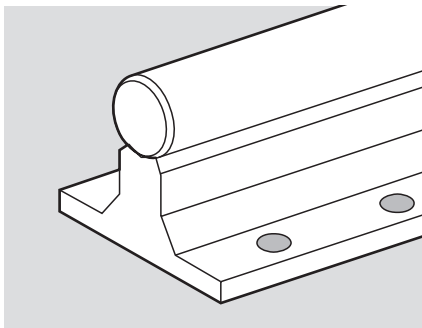

Shaft Ø d [mm]	Part numbers		Mass [kg/m]
	Drilling hole distance T ₁	Drilling hole distance T ₂	
12	R1011 012 ..	R1011 512 ..	1.95
16	R1011 012 ..	R1011 516 ..	2.8
20	R1011 020 ..	R1011 520 ..	4.1
25	R1011 025 ..	R1011 525 ..	5.9
30	R1011 030 ..	R1011 530 ..	8.5
40	R1011 040 ..	R1011 540 ..	13.3
50	R1011 050 ..	R1011 550 ..	20.3
60	R1011 060 ..	–	28.7
80	R1011 080 ..	–	49.7

Shafts:

- 00 = shaft out of heat-treatable steel, h6
- 01 = shaft out of heat-treatable steel, h7
- 30 = shaft out of corrosion-resistant steel, h6
- 31 = shaft out of corrosion-resistant steel, h7
- 60 = Shafts out of hard-chromium plating out of corrosion-resistant steel, h6
- 61 = Shafts out of hard-chromium plating out of corrosion-resistant steel, h7

R1050 Support Rail with drilled holes, length [mm] 600^{-0.5}_{-1.5}

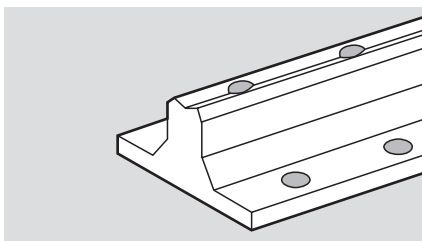

Shaft Ø d [mm]	Part numbers			Mass [kg]
	Drilling hole distance T ₁	Drilling hole distance T ₂	not drilled	
12	R1050 112 00	R1050 212 00	R1050 012 00	0.64
16	R1050 116 00	R1050 216 00	R1050 016 00	0.74
20	R1050 120 00	R1050 220 00	R1050 020 00	1.00
25	R1050 125 00	R1050 225 00	R1050 025 00	1.20
30	R1050 130 00	R1050 230 00	R1050 030 00	1.80
40	R1050 140 00	R1050 240 00	R1050 040 00	2.10
50	R1050 150 00	R1050 250 00	R1050 050 00	3.00
60	R1050 160 00	–	R1050 060 00	4.00
80	R1050 180 00	–	R1050 080 00	6.30

R1050 Support Rail without drilled holes, length, [mm] 600^{-0.5}_{-1.5}

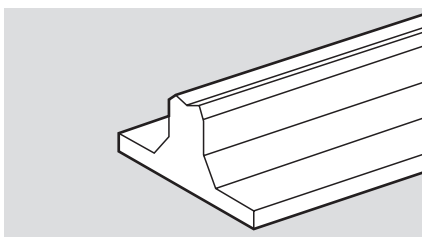

Ordering example

For a shaft support rail with a shaft of non-corrosion steel, 40 mm diameter, 1100 mm length, tolerance quality h7, mounted with shaft support R1050 240 00:

R1014 030 00 / 1100 mm.

Dimensions

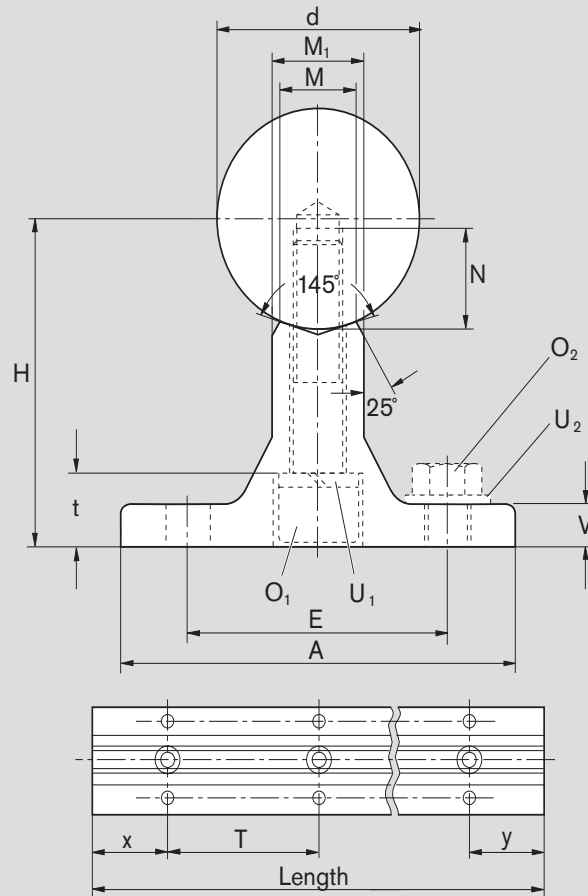

$\varnothing d$	$H^{1)}$	A	V	M	M_1	Dimensions [mm]					$O_2^{3)}$	U_2	Drill hole distances ⁴⁾	
						O_1	U_1	N	E	t			ISO 4762-8.8	DIN125
12	28	43	5	5.8	9	M4x25	4	8	29	5.5	M4x12	4	75	120
16	30	48	5	7	10	M5x25	5	9	33	7	M5x16	5	100	150
20	38	56	6	8.3	11	M6x30	6	11	37	9.6	M6x16	6	100	150
25	42	60	6	10.8	14	M8x35	8	15	42	11	M6x16	6	120	200
30	53	74	8	11	14	M10x40	10	17	51	14	M8x25	8	150	200
40	60	78	8	15	18	M10x45	10	19	55	13.5	M8x25	8	200	300
50	75	90	10	19	22	M12x55	12	21	63	16	M10x30	10	200	300
60	80	100	12	25	30	M14x55	14	25	72	19	M10x30	10	300	-
80	100	125	14	34	42	M16x65	16	28	92	21.5	M12x35	12	300	-

Applications that require very high stiffness and dimensional precision, the drill hole distances for the middle holes (shaft mounting) $0.5 T_1$ should be implemented.

¹⁾ Measured with gauging shaft of nominal diameter d and length approx. 50 mm.

²⁾ DIN 7980 withdrawn. The washer, however, is still available.

³⁾ Applies only to fixing in tapped holes in steel or cast iron.

⁴⁾ T_1 : Traverse load of the Linear Bushing opening and approximate utilization of the load capacities.

T_2 : For general requirements

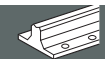

Shaft support rails with ready-mounted steel shafts for open standard and super Linear Bushings

Side fitting

R1015 Steel shaft ready-mounted with shaft supports

R1054 Shaft supports

Material

- Shaft support: Aluminum

Structural Design

- The overall shaft height combined with linear sets allows a large fitting space for drive, control and measuring components
- Fitting edge eases the assembly

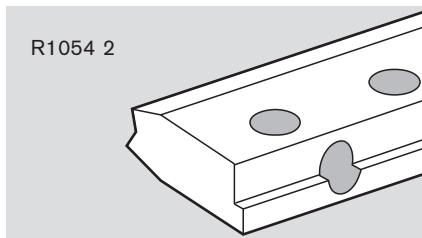
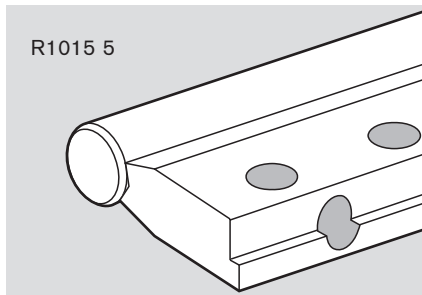
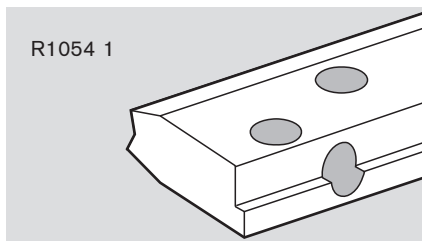
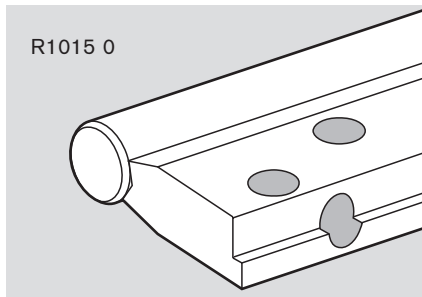

Shaft Ø d [mm]	Part numbers	Mass [kg/m]	Part numbers	Mass [kg]
20	R1015 020 ..	4.1	R1054 120 00	1.0
25	R1015 025 ..	6.0	R1054 125 00	1.3
30	R1015 030 ..	8.7	R1054 130 00	1.9
40	R1015 040 ..	14.3	R1054 140 00	2.7
50	R1015 050 ..	21.5	R1054 150 00	3.7

Shafts:

- 00 = shaft out of heat-treatable steel, h6
- 01 = shaft out of heat-treatable steel, h7
- 30 = shaft out of corrosion-resistant steel, h6
- 31 = shaft out of corrosion-resistant steel, h7
- 60 = Shafts out of hard-chromium plating out of corrosion-resistant steel, h6
- 61 = Shafts out of hard-chromium plating out of corrosion-resistant steel, h7

Shaft Ø d [mm]	Part numbers	Mass [kg/m]	Part numbers	Mass [kg]
20	R1015 520 ..	4.3	R1054 220 00	1.1
25	R1015 525 ..	6.3	R1054 225 00	1.5
30	R1015 530 ..	9.0	R1054 230 00	2.1
40	R1015 540 ..	14.8	R1054 240 00	3.0
50	R1015 550 ..	22.3	R1054 250 00	4.2

Shafts aus:

- 00 = shaft out of heat-treatable steel, h6
- 01 = shaft out of heat-treatable steel, h7
- 30 = shaft out of corrosion-resistant steel, h6
- 31 = shaft out of corrosion-resistant steel, h7
- 60 = Shafts out of hard-chromium plating out of corrosion-resistant steel, h6
- 61 = Shafts out of hard-chromium plating out of corrosion-resistant steel, h7

Ordering example

For a shaft support rail with an h6 shaft of heat-treatable steel, 30 mm diameter, 1200 mm length mounted with shaft support R1054 130 00: R1015 030 00 / 1200 mm.

Dimensions

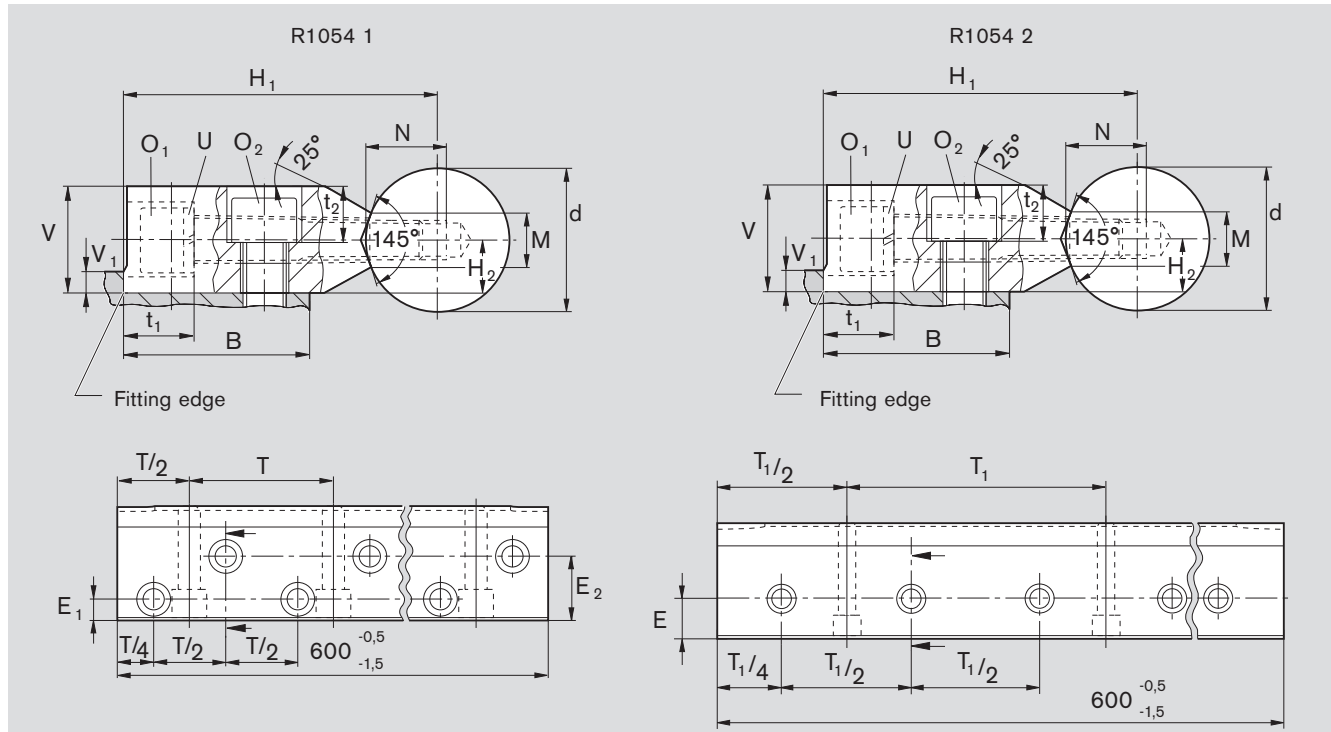

Shaft support R1054 1

Ø d	Dimensions [mm]													O ₁	O ₂ ³⁾	U
	H ₁ ¹⁾	H ₂ ¹⁾	V	M	E ₁	E ₂	T	t ₁	t ₂	V ₁ ²⁾	B ²⁾	N	ISO 4762-8.8			
20	52	7.5	15	8.3	8	22	75	8.5	8.5	4	30	11	M6x45	M6x16	6	
25	62	10	20	10.8	10	26	75	15	11	5.5	36	15	M8x50	M8x20	8	
30	72	12.5	25	11	12	30	100	15.3	13.5	7	42	17	M10x60	M10x25	10	
40	88	15	30	15	12	38	100	19	16	8.5	50	21	M12x70	M12x30	12	
50	105	17.5	35	19	15	45	100	24	18.5	9	60	25	M14x80	M14x35	14	

Shaft support R1054 2

Ø d	Dimensions [mm]													O ₁	O ₂ ³⁾	U
	H ₁ ¹⁾	H ₂ ¹⁾	V	M	E	T ₁	t ₁	t ₂	V ₁ ²⁾	B ²⁾	N	ISO 4762-8.8	ISO 4762-8.8			
20	52	7.5	15	8.3	15	100	8.5	8.5	4	30	11	M6x45	M6x16	6		
25	62	10	20	10.8	18	120	15	11	5.5	36	15	M8x50	M8x20	8		
30	72	12.5	25	11	21	150	15.3	13.5	7	42	17	M10x60	M10x25	10		
40	88	15	30	15	25	200	17.5	16	8.5	50	19	M10x70	M12x30	10		
50	105	17.5	35	19	30	200	21.5	18.5	9	60	21	M12x80	M14x35	12		

¹⁾ Measured with gauging shaft of nominal diameter d and length approx. 50 mm.

²⁾ Recommended design: make mating surface without fitting edge (V₁) and line up parallel via the shafts

³⁾ Applies only to fixing in tapped holes in steel or cast iron.

⁴⁾ DIN 7980 withdrawn. The washer, however, is still available.



Shaft support rails with ready-mounted steel shafts for open standard and super Linear Bushings

Without Flange

R1013 Steel shaft ready-mounted with shaft supports

Material

- Shaft support: Aluminum

Structural design

- This shaft support allows a very compact drive and is especially suitable for designs that can attach the steel shaft from below. The comparison to a conventional flange shows the particularly small overall height of this element.
- Cost effective due to restricted height tolerance.

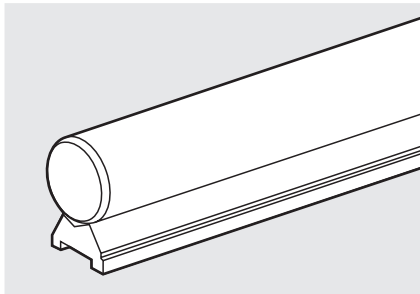
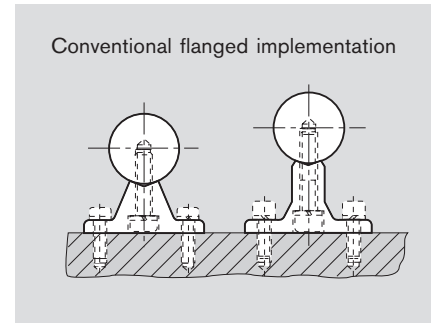
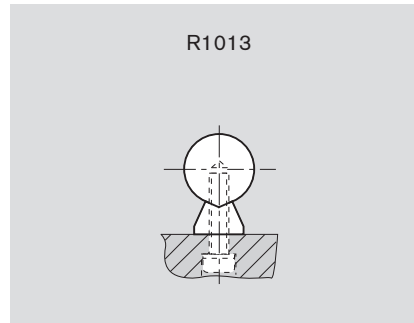

Shaft Ø d [mm]	Part numbers	Mass [kg/m]
12	R1013 012 ..	1.1
16	R1013 016 ..	1.9
20	R1013 020 ..	3.0
25	R1013 025 ..	4.5
30	R1013 030 ..	6.3

Shafts:

- 00 = shaft out of heat-treatable steel, h6
- 01 = shaft out of heat-treatable steel, h7
- 30 = shaft out of corrosion-resistant steel, h6
- 31 = shaft out of corrosion-resistant steel, h7
- 60 = Shafts out of hard-chromium plating out of corrosion-resistant steel, h6
- 61 = Shafts out of hard-chromium plating out of corrosion-resistant steel, h7

Ordering example

For a shaft support rail with an h7 shaft of heat-treatable steel, 25 mm diameter, 2500 mm length:

R1013 025 01 / 2500 mm.

Dimensions

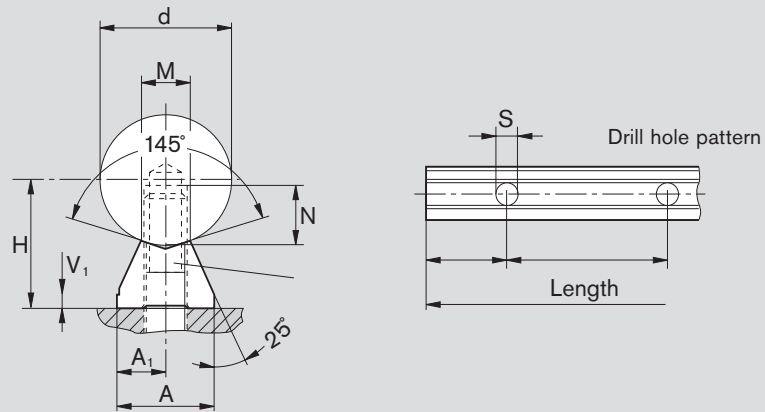

$\varnothing d$	$H^{1)}$ ± 0.05	A	A_1	V_1	Dimensions [mm]					O ISO 4762-8.8
					T	S	N	M		
12	14.5	11	5.5	3	75	4.5	8	5.8	M4	
16	18	14	7.0	3	75	5.5	9	7.0	M5	
20	22	17	8.5	3	75	6.6	11	8.3	M6	
25	26	21	10.5	3	75	9.0	15	10.8	M8	
30	30	23	11.5	3	100	11	17	11	M10	

¹⁾ Measured with gauging shaft of nominal diameter d and length approx. 50 mm. Lengths up to 3000 mm with a parallelism of 10 μm upon request.

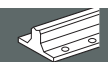

Shaft support rails with ready-mounted steel shafts for open standard and super Linear Bushings

Without Flange, with Fitting Edge

R1016 Steel shaft ready-mounted with shaft supports

Material

- Shaft support: Steel

Structural Design

- This shaft support allows a very compact drive and is especially suitable for designs that can attach the steel shaft from below. The comparison to a conventional flange shows the particularly small overall height of this element.
- Fitting edge eases assembly.

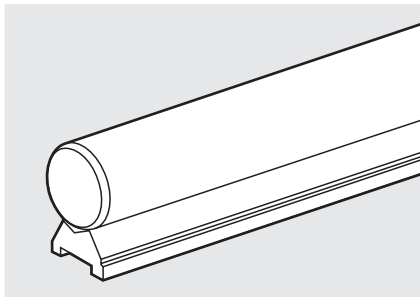
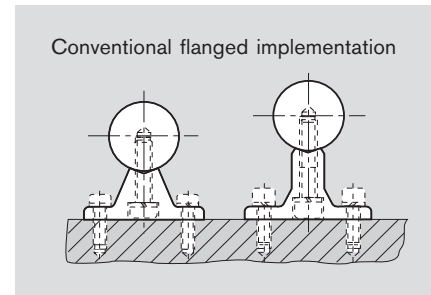
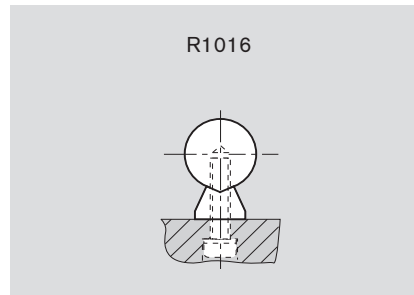

Shaft Ø d [mm]	Part numbers	Mass
		[kg/m]
16	R1016 016 ..	2.5
20	R1016 020 ..	3.8
25	R1016 025 ..	5.6
30	R1016 030 ..	7.6
40	R1016 040 ..	13.4
50	R1016 050 ..	20.2

Shafts:

00 = shaft out of heat-treatable steel, h6

01 = shaft out of heat-treatable steel, h7

30 = shaft out of corrosion-resistant steel, h6

31 = shaft out of corrosion-resistant steel, h7

60 = Shafts out of hard-chromium plating out of corrosion-resistant steel, h6

61 = Shafts out of hard-chromium plating out of corrosion-resistant steel, h7

Ordering example

For a shaft support rail with an h7 shaft of heat-treatable steel, 30 mm diameter, 900 mm length:

R1016 030 01 / 900 mm.

Dimensions

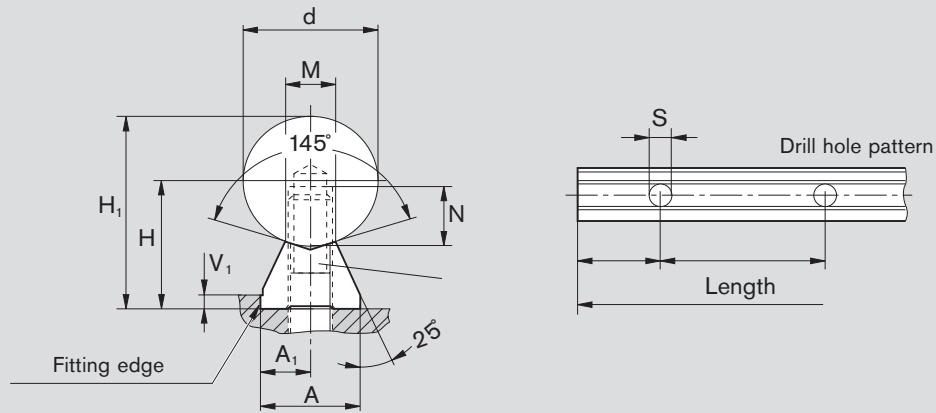

$\emptyset d$	$H^{1)}$	H_1	Dimensions [mm]		V_1	T	S	N	M	O	Tolerances within one grade [μm]		
			A ± 0.02	A_1 ± 0.02							$H^{2)}$	Shaft h6 $H_1^{3)}$	Shaft h7 $H_1^{3)}$
16	18	26	14	7	3	75	5.5	9	7	M5	20	32	36
20	22	32	17	8.5	3	75	6.6	11	8.3	M6	20	33	38
25	26	38.5	21	10.5	3	75	9	15	10.8	M8	20	33	38
30	30	45	23	11.5	3	100	11	17	11	M10	20	33	38
40	39	59	30	15	4	100	13.5	21	15	M12	20	35	41
50	46	71	35	17.5	5	100	15.5	25	19	M14	20	35	41

¹⁾ Tolerance: ± 0.02 mm; sorted by height - delivered to 20 μm .

²⁾ Measured with gauging shaft of nominal diameter d and length approx. 50 mm. Lengths up to 3000 mm with a parallelism of 10 μm upon request.

³⁾ Inclusive shaft tolerance (statistically determined).

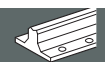

Shaft support rails with ready-mounted steel shafts für Radial Linear Bushings

Flanged

R1018 Steel shaft ready-mounted with shaft supports

Material

- Shaft support: Steel

Structural Design

- Large design offers very high stiffness
- Fitting edge eases assembly
- For guides with Radial Linear Bushings and Linear sets with Radial Linear Bushings

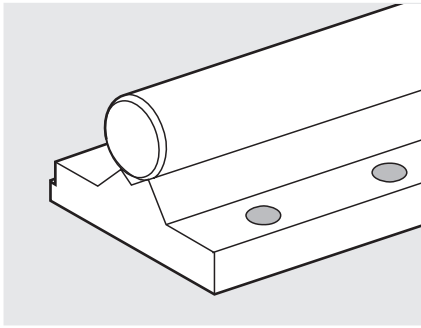

Shaft Ø d [mm]	Part numbers	Mass
		[kg/m]
30	R1018 030 ..	20.5
40	R1018 040 ..	31
50	R1018 050 ..	50
60	R1018 060 ..	70
80	R1018 080 ..	121

Shafts:

- 00 = shaft out of heat-treatable steel, h6
- 30 = shaft out of corrosion-resistant steel, h6
- 60 = Shafts out of hard-chromium plating out of corrosion-resistant steel, h6

R1052 Shaft support

Length [mm] $600_{-1.5}^{-0.5}$

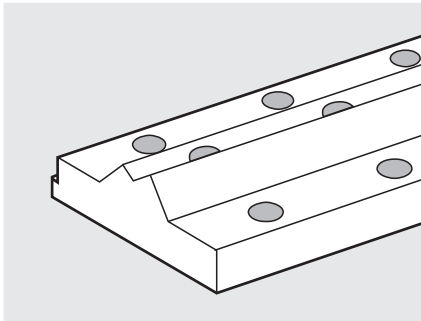

Shaft Ø d [mm]	Part numbers	Mass
		[kg]
30	R1052 130 00	9.0
40	R1052 140 00	12.7
50	R1052 150 00	20.7
60	R1052 160 00	29.0
80	R1052 180 00	48.9

Ordering example

For a shaft support rail with an h7 shaft of heat-treatable steel, 30 mm diameter, 1200 mm length mounted with shaft support R1052 130 00:
R1018 030 00 / 1200 mm.

Dimensions

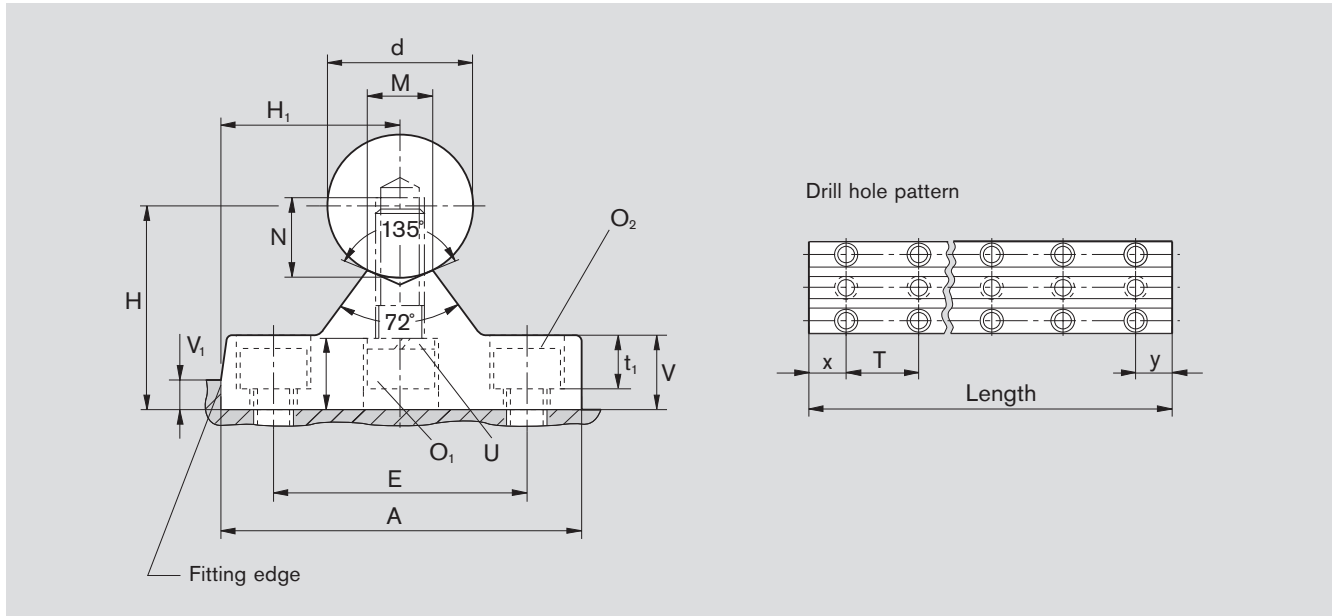

Ø d	A	Dimensions [mm]													
		H ¹⁾ js7	H ₁ js7	V	V ₁ ²⁾	M -0.5	E	T	t ₁	t ₂	N	O ₁ ISO 4762-8.8	O ₂ ISO 4762-8.8	U DIN7980 ³⁾	
30	80	50	40	19	7	13	55	60	22	13,5	17	M10x30	M10	10	
40	100	60	50	22	8,5	18	70	75	22	16	21	M12x40	M12	12	
50	125	75	62.5	30	9	23	90	100	28	21	28	M16x50	M16	16	
60	150	90	75	34	13	27	110	120	34	25.5	32	M20x60	M20	20	
80	200	115	100	42	18	37	140	150	38.5	30.5	40	M24x80	M24	24	

¹⁾ Measured with gauging shaft of nominal diameter d and length approx. 50 mm.

²⁾ Recommended design: make mating surface without fitting edge (V₁) and line up parallel via the shafts

³⁾ DIN 7980 withdrawn. The washer, however, is still available.

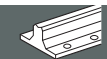

Shaft support rails with ready-mounted steel shafts für Radial Linear Bushings

Side Fitting

R1020 Steel shaft ready-mounted with shaft supports

Material

- Shaft support: Steel

Structural Design

- Large design offers very high stiffness
- Fitting edge eases assembly
- For guides with Radial Linear Bushings and Linear sets with Radial Linear Bushings side opening

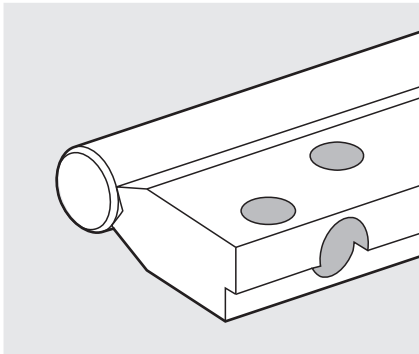

Shaft Ø d [mm]	Part numbers	Mass [kg/m]
30	R1020 030 ..	20
40	R1020 040 ..	36
50	R1020 050 ..	54
60	R1020 060 ..	82
80	R1020 080 ..	136

Shafts:

- 00 = shaft out of heat-treatable steel, h6
- 30 = shaft out of corrosion-resistant steel, h6
- 60 = Shafts out of hard-chromium plating out of corrosion-resistant steel, h6

R1053 Shaft support

Length [mm] $600_{-1.5}^{-0.5}$

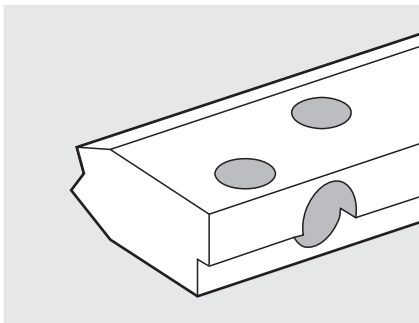

Shaft Ø d [mm]	Part numbers	Mass [kg]
30	R1053 130 00	8.7
40	R1053 140 00	15.5
50	R1053 150 00	23.0
60	R1053 160 00	36.0
80	R1053 180 00	58.0

Ordering example

For a shaft support rail with an h7 shaft of heat-treatable steel, 30 mm diameter, 1200 mm length mounted with shaft support R1053 130 00:
R1020 030 00 / 1200 mm.

Dimensions

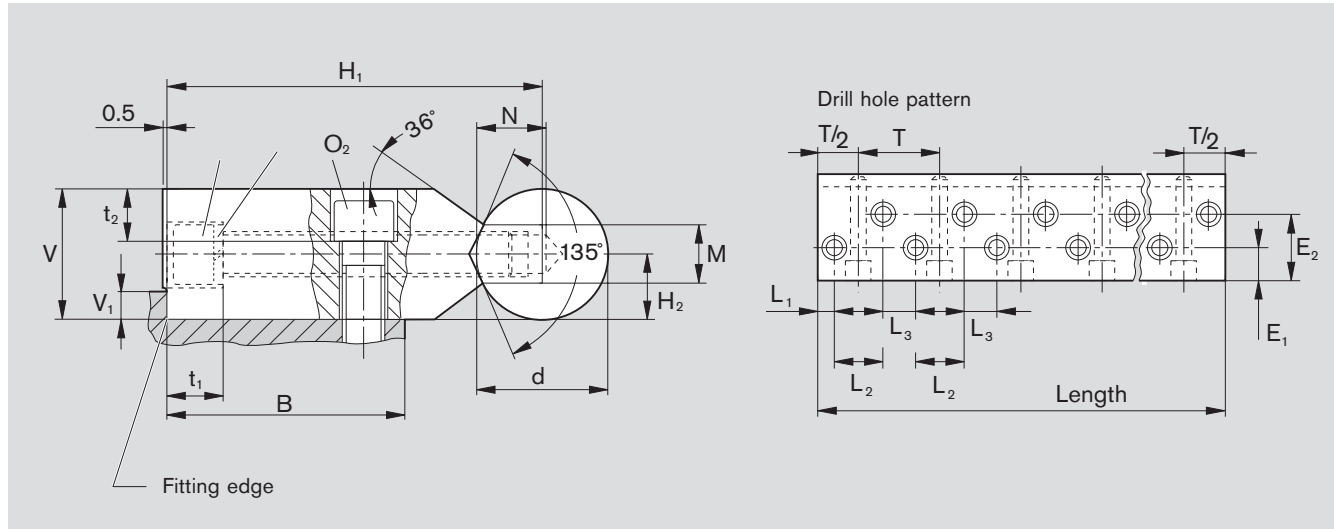

Ø d	Dimensions [mm]																		
	H ₁	H ₂ ¹⁾	V	V ₁ ²⁾	M	E ₁	E ₂	T	L ₁	L ₂	L ₃	t ₁	t ₂	B ³⁾	N	O ₁	O ₂ ⁴⁾	U	
±0,015	±0,013		max.	-0.5	±0.2	±0.2										ISO 4762-8.8	ISO 4762-8.8	DIN7980 ⁵⁾	
30	90	15	30	7	13	23	46	60	12	36	24	13.5	13.5	57	17	M10x80	M10x30	10	
40	115	20	40	8.5	18	30	60	75	15	45	30	16	16	73	21	M12x100	M12x40	12	
50	140	25	50	9	23	38	76	100	20	60	40	23	21	92	28	M16x120	M16x50	16	
60	180	30	60	13	27	50	100	120	24	72	48	25.5	25.5	120	32	M20x160	M20x60	20	
80	220	40	80	18	37	60	120	150	30	90	60	44	30.5	145	40	M24x180	M24x80	24	

- ¹⁾ Measured with gauging shaft of nominal diameter d and length approx. 50 mm.
- ²⁾ Recommended design: make mating surface without fitting edge (V₁) and line up parallel via the shafts
- ³⁾ Recommended design for connecting parts.
- ⁴⁾ Applies only to fixing in tapped holes in steel or cast iron.
- ⁵⁾ DIN 7980 withdrawn. The washer, however, is still available.

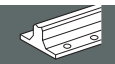

Shaft support rails with ready-mounted steel shafts for Radial Compact Sets

Flanged, with Fitting Edge

R1012 Steel shaft ready-mounted with shaft supports

Material

- Shaft support: Steel

Structural design

- Together with Radial Compact sets you can achieve guidance with very low profile
- Fitting edge eases assembly

Assembly

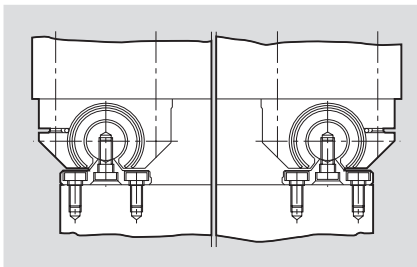

Without fitting edge

- Align first shaft with the support rail (ready-mounted unit), using a straightedge, and screw into place.
- Align second shaft in parallel, preferably using a straightedge (see "Parallelism", General Technical Data and Mounting Instructions) and screw shaft support rail in place.
- Push Radial Compact Sets onto the shafts and screw into place on the machine table.

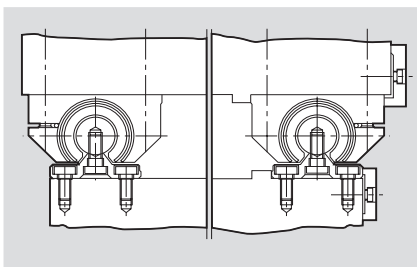

With fitting edge

- One fitting edge on the machine base and one on the machine table, or
 - only one fitting edge on the machine base.
- Press first shaft with support rail against fitting edge and screw into place.
 - Align second shaft in parallel, preferably using a straightedge (see "Parallelism", General Technical Data and Mounting Instructions) and screw shaft support rail into place.
 - Push Radial Compact Sets onto the shafts and
 - in case of a) Press Radial Compact Sets of the first shaft against fitting edge of the machine table and screw into place; then screw Radial Compact Sets of the second shaft into place on machine table, or
 - in case of b) Screw Radial Compact Sets into place on machine table.

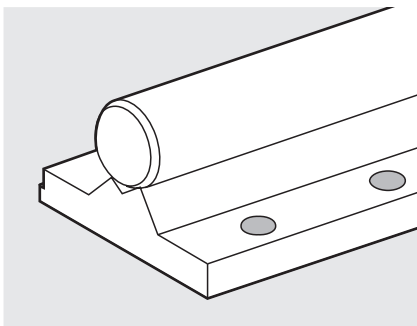

Shaft Ø d [mm]	Part numbers	Mass [kg/m]
30	R1012 030 ..	12,3
40	R1012 040 ..	19,6
50	R1012 050 ..	31,0
60	R1012 060 ..	45,6
80	R1012 080 ..	79,2

Shafts:

- 00 = shaft out of heat-treatable steel, h6
- 30 = shaft out of corrosion-resistant steel, h6
- 60 = Shafts out of hard-chromium plating out of corrosion-resistant steel, h6

Ordering example

For a shaft support rail with an h6 shaft of heat-treatable steel, 40 mm diameter, 2400 mm length:
R1012 040 00 / 900 mm.

Dimensions

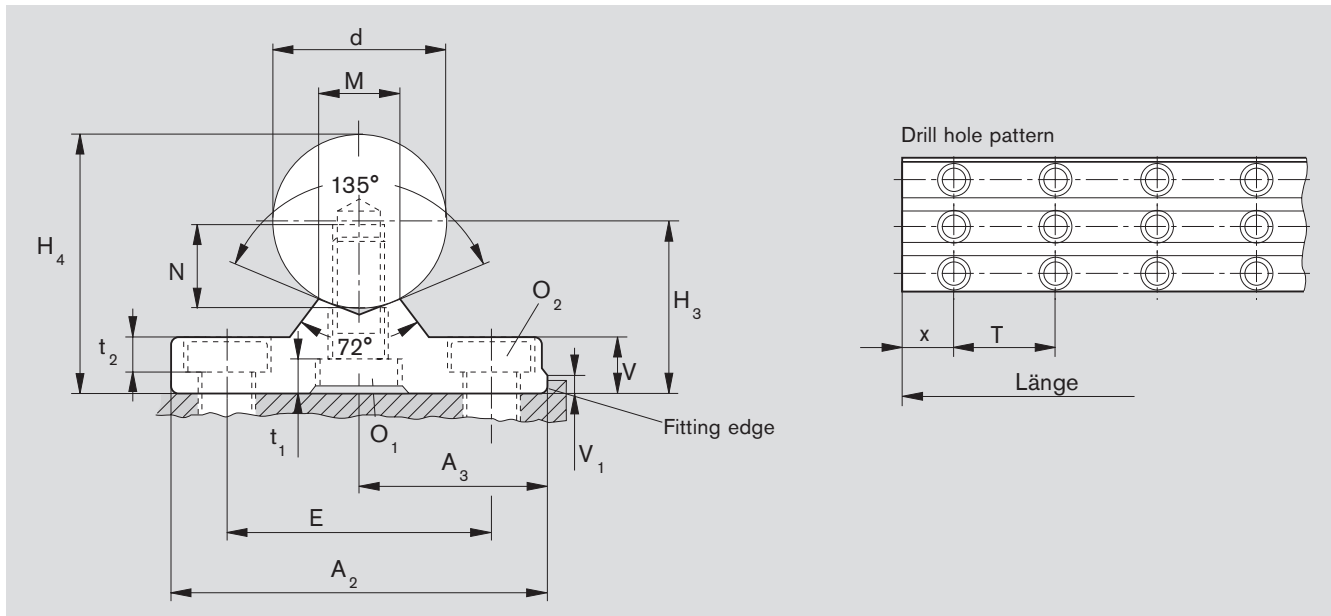

Dimensions [mm]																Tolerances within one grade [μm]	
$\emptyset d$	A_2	A_3	$H_3^{1)}$	H_4	V	V_1	M	E	O_1	t_1	N	O_2	t_2	T	$H_3^{2)}$	Shaft h6 $H_4^{3)}$	
		± 0.02					-0.5		DIN6912-8.8			DIN7984-8.8					
30	68	34	33	48	11	6	13	46	M10x25	9	17	M10	6.8	60	20 ⁴⁾	29	
40	85	42.5	40	60	13	6	18	58	M12x30	10	21	M12	8.4	75	20 ⁴⁾	31	
50	105	52.5	50	75	17	8	23	74	M16x40	10.8	28	M16	10.5	100	20 ⁴⁾	31	
60	130	65	60	90	20	8	27	90	M20x40	16	32	M20	12.5	120	20	33	
80	170	85	80	120	26	10	37	120	M24x60	16	40	M24	16	150	20	33	

¹⁾ Tolerance: ± 0.02 mm; sorted by height - delivered to 20 μm .

²⁾ Measured with gauging shaft of nominal diameter d and length approx. 50 mm.

³⁾ Inclusive shaft tolerance (statistically determined).

⁴⁾ Lengths up to 3000 mm with a parallelism of 10 μm upon request.

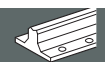

Shaft Support Blocks

The Advantages

- For easy assembly and fast alignment
- Precise execution with fitting edge
- More cost-effective than customer-built designs

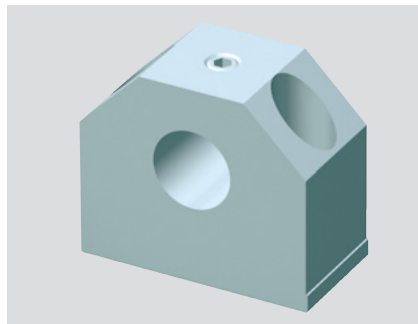

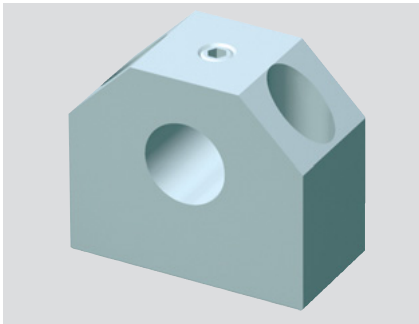
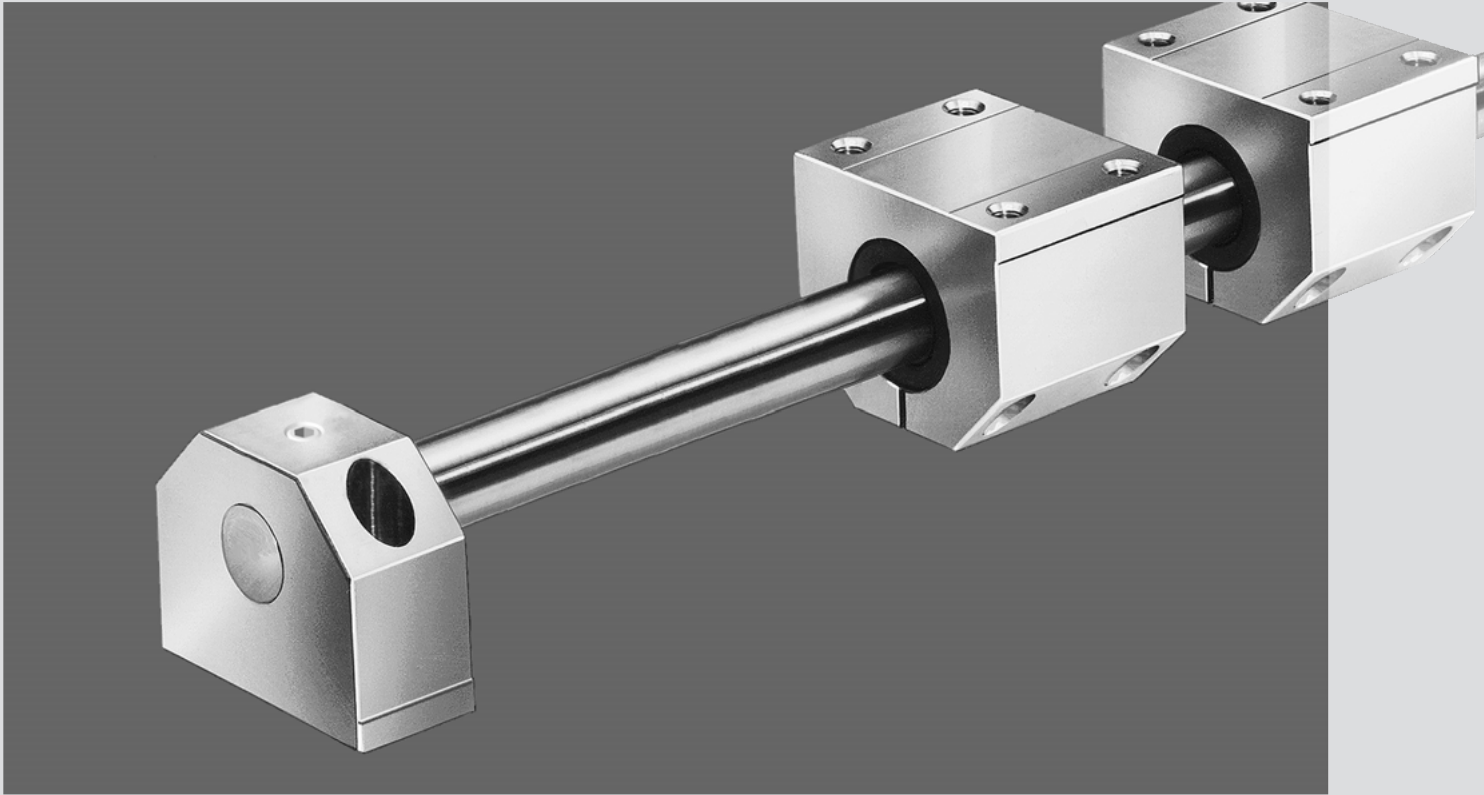

Shaft support blocks

Shaft support blocks, R1055

Material

- Spheroidal graphite cast iron

Structural design

- Slim design
- Side clamping

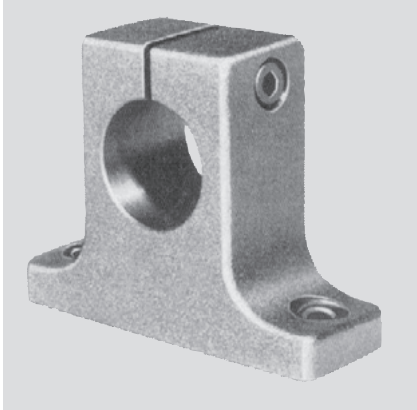

Shaft Ø d [mm]	Part numbers	Mass [kg]
8	R1055 008 00	0.03
12	R1055 012 00	0.06
16	R1055 016 00	0.12
20	R1055 020 00	0.22
25	R1055 025 00	0.37
30	R1055 030 00	0.55
40	R1055 040 00	0.97
50	R1055 050 00	1.90
60	R1055 060 00	3.60
80	R1055 080 00	7.30

Dimensions

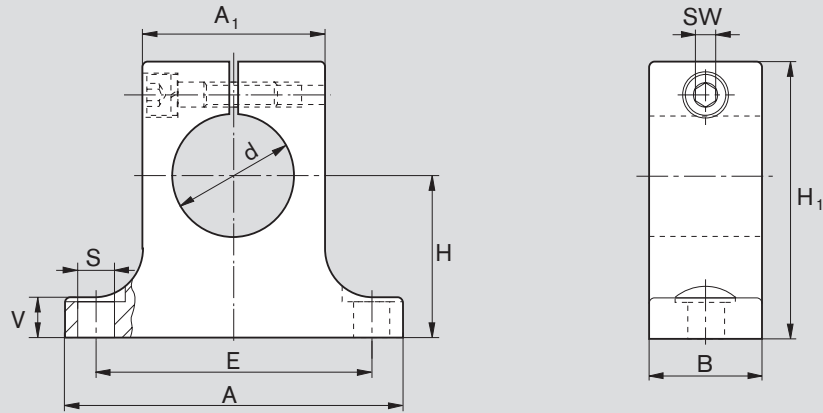

Dimensions [mm]										
$\varnothing d$	d H8	$H^{1)}$	$H_1^{2)}$	$A^{2)}$	$A_1^{2)}$	$B^{2)}$	E	$S^{3)}$	$V^{2)}$	SW
8	8	15±0.010	27	32	16	10	25±0.15	4.5	5	2.5
12	12	20±0.010	35	42	20	12	32±0.15	5.5	5.5	3
16	16	25±0.010	42	50	26	16	40±0.15	5.5	6.5	3
20	20	30±0.010	50	60	32	20	45±0.15	5.5	8	3
25	25	35±0.010	58	74	38	25	60±0.15	6.6	9	4
30	30	40±0.010	68	84	45	28	68±0.20	9.0	10	5
40	40	50±0.010	86	108	56	32	86±0.20	11.0	12	6
50	50	60±0.015	100	130	80	40	108±0.20	11.0	14	6
60	60	75±0.015	124	160	100	48	132±0.25	13.5	15	8
80	80	100±0.015	160	200	130	60	170±0.50	17.5	22	10

¹⁾ Relative to shaft nominal dimension d .

²⁾ Tolerance to DIN 1685 – GTB 15.

³⁾ Mounting screws to ISO 4762-8.8.



Shaft support blocks

Shaft support blocks, R1057

Material

- Aluminum

Structural design

- Rigid mounting of shaft due to extra-wide construction
- Clamping from above for better accessibility
- Higher security by clamping screw with larger thread diameter
- Thread for attachment from below
- Drill holes for attachment from above
- With fitting edge for easy alignment

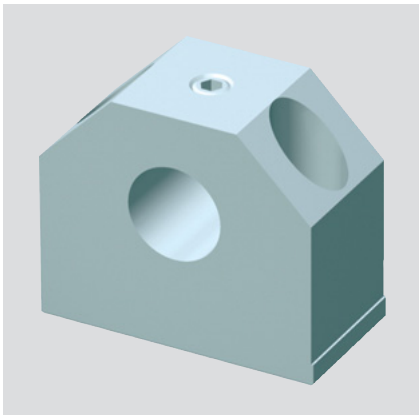

Shaft Ø d [mm]	Part numbers	Mass [kg]
10	R1057 010 00	0.05
12	R1057 012 00	0.06
16	R1057 016 00	0.11
20	R1057 020 00	0.18
25	R1057 025 00	0.35
30	R1057 030 00	0.48
40	R1057 040 00	0.90
50	R1057 050 00	1.50
60	R1057 060 00	3.00

Dimensions

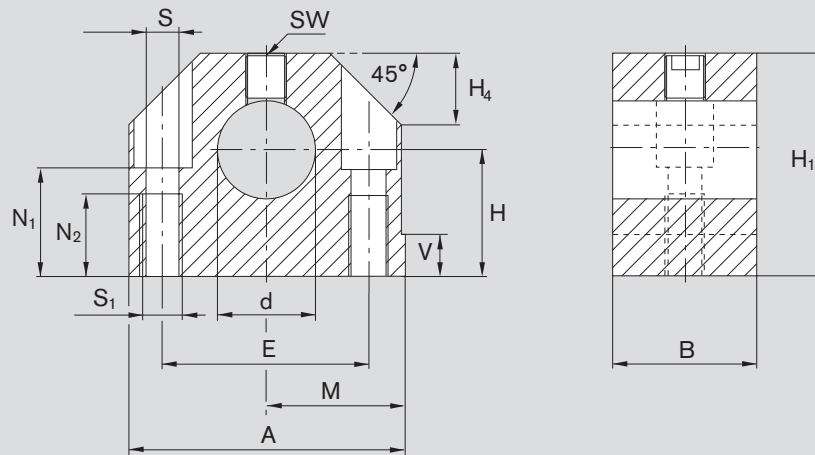

$\varnothing d$	d	$H^{1)}$	H_1	$M^{1)}$	Dimensions [mm]					S_1	N_1	N_2	V	H_4	SW	Tightening torque [Nm]
					A	B	E	$S^2)$	S							
10	10	18	31	20	40	20	27 ± 0.15	5.3	M6	14	13	5	10	2.5	3.8	
12	12	20	35	21.5	43	20	30 ± 0.15	5.3	M6	16.5	13	5	10	2.5	3.8	
16	16	25	42	26.5	53	24	38 ± 0.15	6.6	M8	21	18	5	13	3	6.6	
20	20	30	51	30	60	30	42 ± 0.15	8.4	M10	25	22	5	16	4	16	
25	25	35	61	39	78	38	56 ± 0.15	10.5	M12	30	26	6.5	20	5	30	
30	30	40	70	43.5	87	40	64 ± 0.15	10.5	M12	34	26	8	22	5	30	
40	40	50	88	54	108	48	82 ± 0.15	13.5	M16	44	34	10	28	6	52	
50	50	60	105	66	132	58	100 ± 0.20	17.5	M20	49	42	12	37	8	120	
60	60	75	130	82	164	74	124 ± 0.20	22	M27	59	42	13	42	10	220	

¹⁾ Relative to shaft nominal dimension d .

²⁾ Mounting screws to ISO 4762-8.8.



Shaft support blocks

Shaft support blocks, R1056
with flange

Material

- Lamellar graphite cast iron

Structural design

- The assembly of the shafts in customer bore holes makes it possible for the flanged shaft blocks to align the shaft and prevent an overloading of the Linear Bushings by unparallel shafts
- Side clamping screw

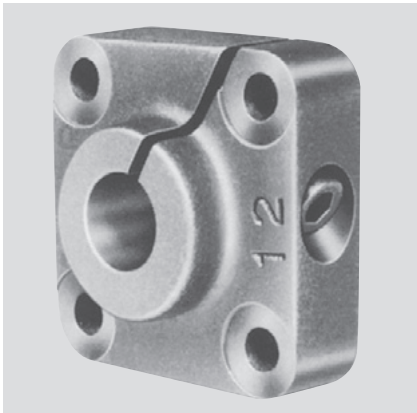

Shaft Ø d [mm]	Part numbers	Mass [kg]
12	R1056 012 00	0.15
16	R1056 016 00	0.21
20	R1056 020 00	0.28
25	R1056 025 00	0.41
30	R1056 030 00	0.75
40	R1056 040 00	1.65
50	R1056 050 00	2.60

Dimensions

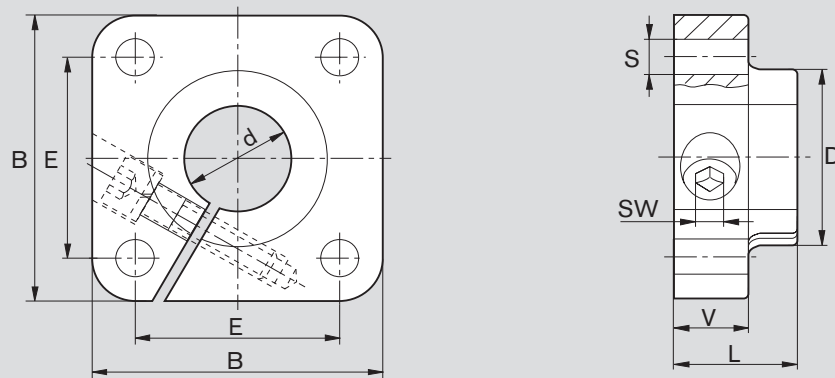

$\varnothing d$	d H7	$B^{1)}$	$L^{1)}$	Dimensions [mm]				SW
				$D^{1)}$	E	S H13	$V^{1)}$	
12	12	42	20	23.5	30 ± 0.12	5.5	12	3
16	16	50	20	27.5	35 ± 0.12	5.5	12	3
20	20	54	23	33.5	38 ± 0.15	6.6	14	4
25	25	60	25	42.0	42 ± 0.15	6.6	16	5
30	30	76	30	49.5	54 ± 0.25	9.0	19	6
40	40	96	40	65.0	68 ± 0.25	11.0	26	8
50	50	106	50	75.0	75 ± 0.25	11.0	36	8

¹⁾ Tolerance to DIN 1686 – GTB 15.



Shaft support blocks

Compact-Shaft support blocks,
R1058

Material

- Aluminium

Structural design

- Especially low profile fitting for Linear sets with compact Linear Bushings
- Clamping from above for better access
- Higher security by clamping screw with larger thread diameter
- Thread for attachment from below
- Drill holes for attachment from above

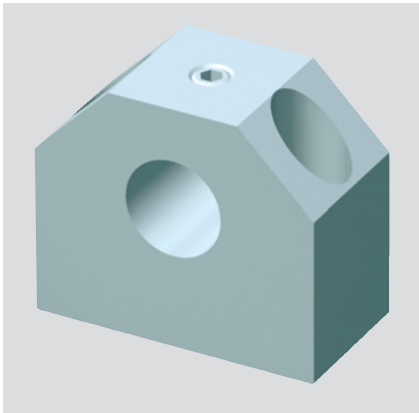

Shaft Ø d [mm]	Part numbers	Mass [kg]
12	R1058 012 00	0.045
16	R1058 016 00	0.065
20	R1058 020 00	0.110
25	R1058 025 00	0.170
30	R1058 030 00	0.220
40	R1058 040 00	0.470
50	R1058 050 00	0.820

Dimensions

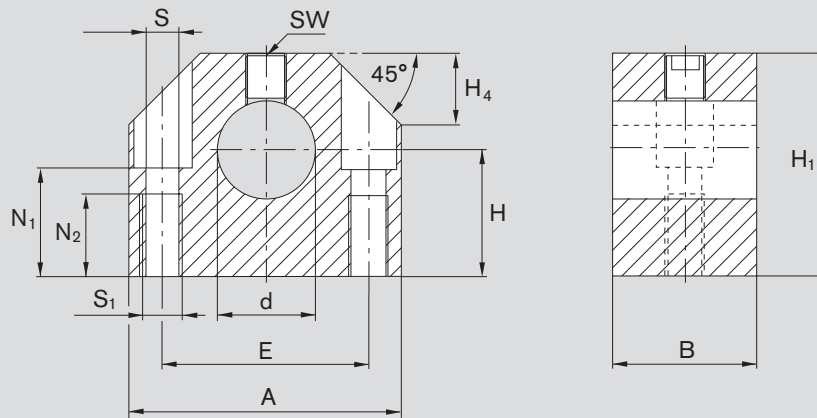

$\varnothing d$	d	Dimensions [mm]											Tightening torque [Nm]
		H ¹⁾ ±0.01	H ₁	A	B	E ±0.15	S ²⁾	S ₁	N ₁	N ₂	H ₄	SW	
12	12	19	33	40	18	27	5.3	M6	16	13	11	2.5	3.8
16	16	22	38	45	20	32	5.3	M6	18	13	13	2.5	3.8
20	20	25	45	53	24	39	6.6	M8	22	18	15	3.0	6.6
25	25	31	54	62	28	44	8.4	M10	26	22	17	4.0	16
30	30	34	60	67	30	49	8.4	M10	29	22	19	4.0	16
40	40	42	76	87	40	66	10.5	M12	38	26	24	5.0	30
50	50	50	92	103	50	80	13.5	M16	46	34	30	6.0	52

¹⁾ Relative to shaft nominal dimension d.

²⁾ Mounting screws to ISO 4762-8.8.



Shaft support blocks

Compact shaft support blocks,
R1059
Corrosion-resistant

Material

- Especially rust and acid resistant chrome nickel steel

Structural design

- Especially low profile fitting for Linear sets with compact Linear Bushings
- Clean design for applications in the Medical, Food, Chemical and Semiconductor industries
- Clamping from above
- Plastic cover for clamping screw (included)
- Higher security by clamping screw with larger thread diameter
- Thread for attachment from below
- The especially deep drill holes can be bored through for attachment from above

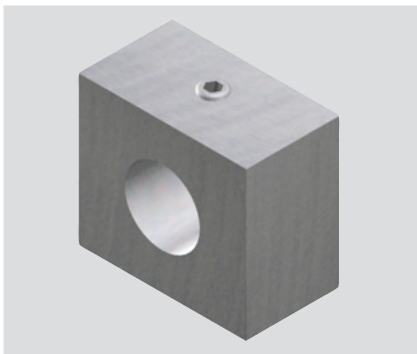

Shaft Ø d [mm]	Part numbers	Mass [kg]
12	R1059 012 00	0.16
16	R1059 016 00	0.23
20	R1059 020 00	0.37
25	R1059 025 00	0.59
30	R1059 030 00	0.73
40	R1059 040 00	1.60

Dimensions

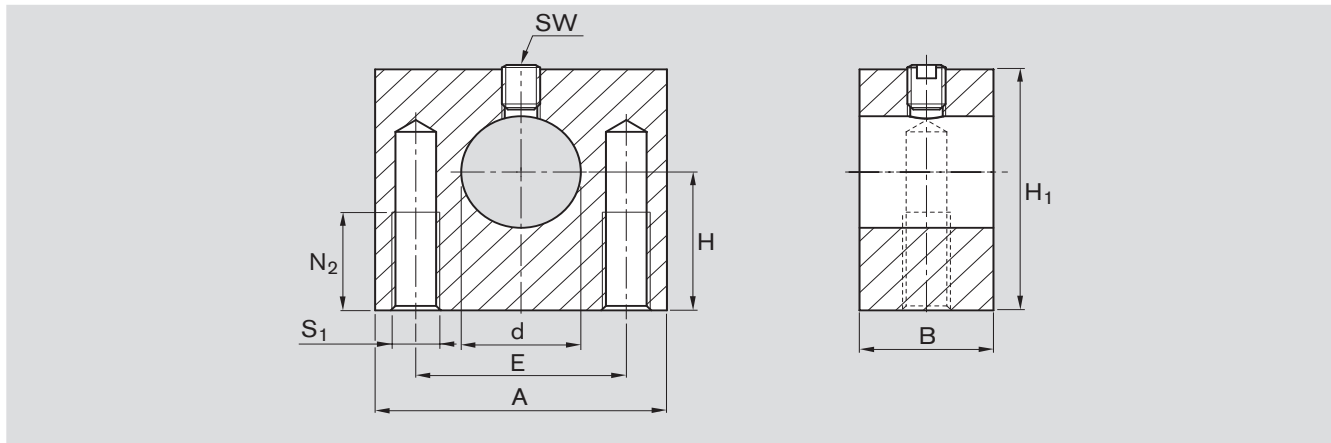

Dimensions [mm]										Tightening torque
$\varnothing d$	d H7	H ¹⁾ ± 0.01	H ₁	A	B	E ± 0.15	N ₂	S ₁	SW	[Nm]
12	12	19	33	40	18	27	13	M6	3	6.6
16	16	22	38	45	20	32	13	M6	3	6.6
20	20	25	45	53	24	39	18	M8	4	16
25	25	31	54	62	28	44	22	M10	4	16
30	30	34	60	67	30	49	22	M10	4	16
40	40	42	76	87	40	66	26	M12	5	30

¹⁾ Relative to shaft nominal dimension d.



Bosch Rexroth Corporation
Linear Motion and
Assembly Technologies
14001 South Lakes Drive
Charlotte, NC 28273
Telephone (800) 438-5983
Facsimile (704) 583-0523
www.boschrexroth-us.com

Bosch Rexroth Corporation
Corporate Headquarters
5150 Prairie Stone Parkway
Hoffman Estates, IL 60192-3707
Telephone (847) 645-3600
Facsimile (847) 645-6201

Bosch Rexroth Corporation
Industrial Hydraulics
2315 City Line Road
Bethlehem, PA 18017-2131
Telephone (610) 694-8300
Facsimile (610) 694-8467

Bosch Rexroth Corporation
Electric Drives and Controls
5150 Prairie Stone Parkway
Hoffman Estates, IL 60192-3707
Telephone (847) 645-3600
Facsimile (847) 645-6201

Bosch Rexroth Corporation
Pneumatics
1953 Mercer Road
Lexington, KY 40511-1021
Telephone (859) 254-8031
Facsimile (859) 281-3491

Bosch Rexroth Corporation
Mobile Hydraulics
1700 Old Mansfield Road
Wooster, OH 44691-0394
Telephone (330) 263-3300
Facsimile (330) 263-3333