

Rex[®]

TableTop[®]

Chains

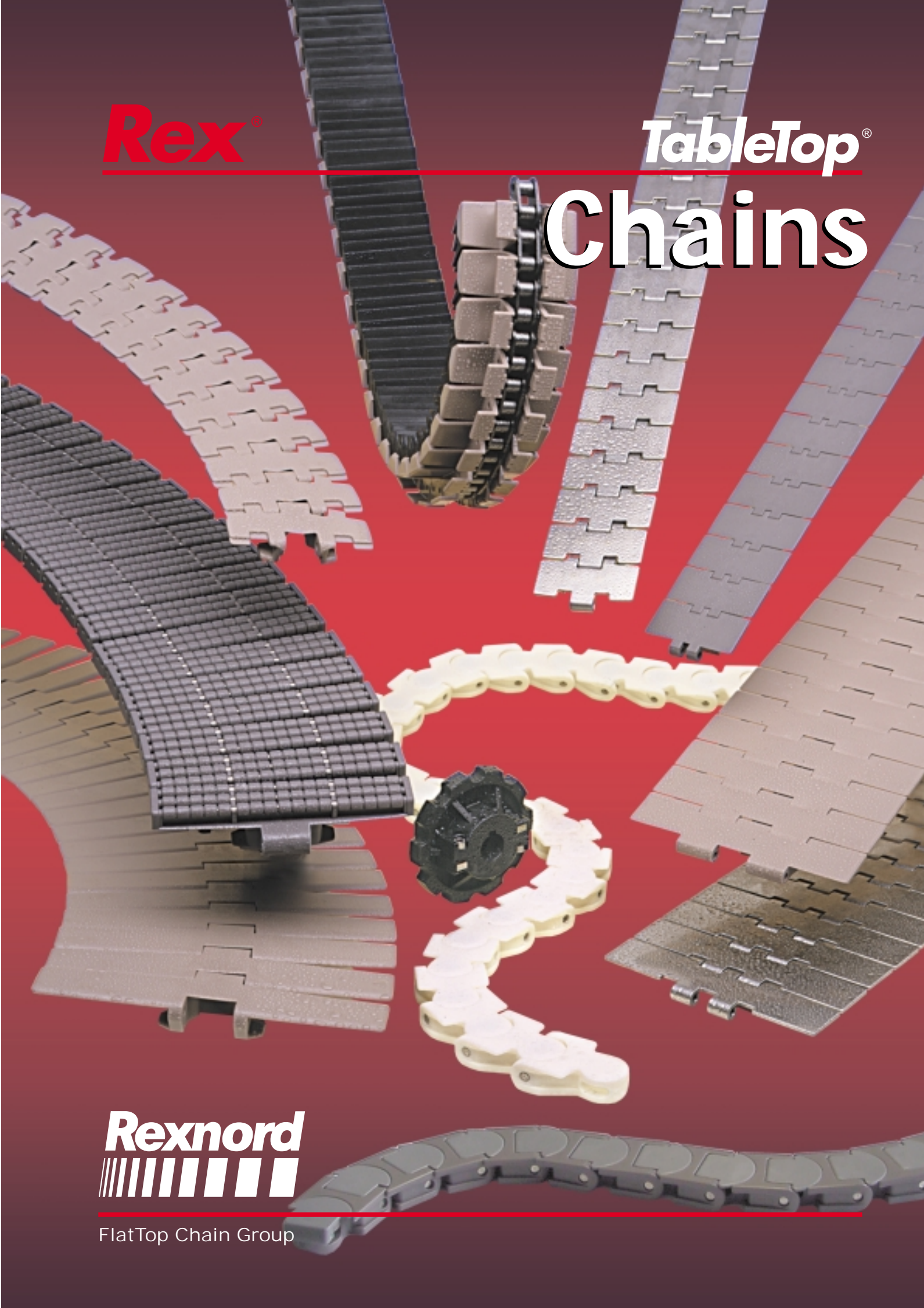

Rexnord
|||||

FlatTop Chain Group

SALES OFFICES AND / OR DISTRIBUTION CENTRE

EUROPE

AUSTRIA: Wien
DENMARK: Copenhagen
FRANCE: Paris, Lyon
GERMANY: Betzdorf,
Dusseldorf, Siegen, Stuttgart
GREAT BRITAIN: Warrington,
ITALY: Correggio (RE)
NETHERLANDS: 's-Gravenzande

NORTH AMERICA

CANADA: Edmonton, Montreal,
Toronto, Vancouver
UNITED STATES: Atlanta (GA),
Columbus (OH), Dallas (TX),
Fresno (CA), Grafton (WI)
(14 regional sales offices
throughout the U.S.A.)

LATIN & SOUTH AMERICA

Headquarters: Miami (FL)-USA
MEXICO: Cordoba, Guadalajara,
Mexico City, Queretaro
BRAZIL: Sao Leopoldo, Sao Paulo

ASIA & FAR EAST

AUSTRALIA: Sydney
SINGAPORE: Singapore
KOREA: Seoul
PHILIPPINES: Manila



Registered Trade marks:

Rex[®] **TableTop**[®] **Rex - OPTI-Plus**[®] **Rex - HP**[™] **Rex - LF**[®] **CurveMaster**[™]

Global commitment



Marbett started in 1968 as third parties plastic parts specialist making design, moulds and injection moulding. In few years we specialised in plastic components for the food and beverage industry because of the high concentration of OEMs in the area between Bologna and Parma where Marbett is based, offering the first complete catalogue of conveyor components specifically designed for the food and beverage industry.

Sprockets for TableTop® chains, idler wheels, ram-extruded chain wear strips and product side guides, chain return system made with rollers, serpentine wear strips or wear shoes, adjustable clamps and brackets for side guides, conveyor supporting elements like brackets for standard tubes, stiffening joints, bipods and tripods, adjustable levelling feet and ball bearing supports.

Now Marbett is part of the Rexnord group, inventor of TableTop® chains and world leader in chains and conveyor components for the food, beverage, packaging, and industrial automation, and takes advantage of the integration into this international structure with higher design, commercial and financial capabilities. All these capabilities are dedicated to the best customer satisfaction through an integral quality policy covering all the aspects of the service, including the solution on the field of application problems and the development of new products in co.operation with the customers to give always the best solution to the market changing demands.



Quality System Certified



- *State of the art equipment and technology*
- *Continuous quality improvement*
- *Widest range of products developed in close collaboration with leading original equipment manufacturers*
- *Continuous training of employees in all sectors*
- *High quality level*
- *Dedicated application engineering*
- *Use of FDA approved materials and development of products, certified by USDA*
- *ISO 9001 Certification*



*Quality
System
Certified*



Rexnord Marbett

COMPANY
WITH QUALITY SYSTEM
CERTIFIED BY DNV
== **ISO 9001** ==



Rex - OPTI-Plus®

Special-Alloy Stainless Steel

In collaboration with the steel industry, Rexnord has developed a special exclusive alloy of chrome steel with nickel. This results in excellent strength properties, as well as improved corrosion-resistance.

The most outstanding properties of *Rex-OPTI-Plus*® are its high resistance to wear, its ground finish, and 40% higher strength.

In addition no "break in" is required thus insuring maximum performance from startup. *Rex-OPTI-Plus*® is the preferred choice for new or replacement installations.

Load carrying capacity

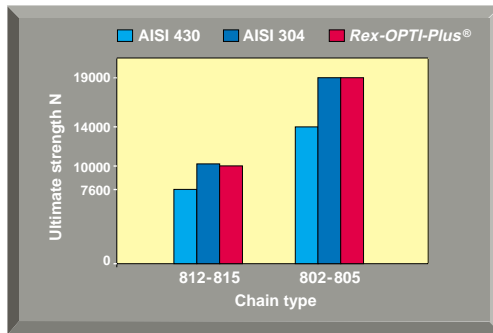

Rex-OPTI-Plus® has a 40% higher load carrying capacity than standard ferritic alloys.

Longer sliding wear life

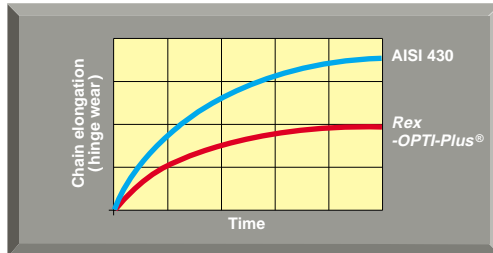

AISI 303

AISI 304

Stainless Steel

An austenitic steel generally known as 18/8 steel offering excellent corrosion and oxidation resistance.

Ideal for the food industry, dairy and cheese production, beer production, and the pharmaceutical industry.

Stainless steel is cold rolled and responsive to magnets.

Rex - HP™

High Performance

Rex HP™ High Performance.

Longer sliding wear life, reduced chain elongation, lowest available friction.

This material has the lowest coefficient of friction, available on the market.

This material is especially suitable for applications, where external lubrication is not possible.

Operating temperature of *Rex HP*™ material:

in air (- 40 to + 80 °C)

in hot water (+ 65 °C)

Colour: dark grey.

Longer sliding wear life *

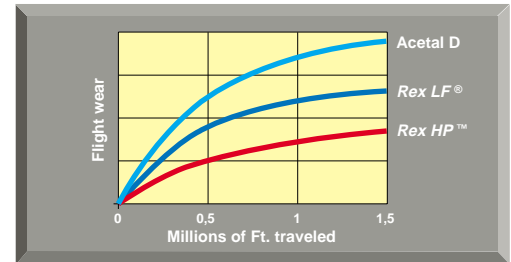

Rex HP™ high performance resin can increase wear life up to 40%. Extensive testing has proven that new HP material can reduce wear as much as 40% over acetal and 25% over *Rex LF*® acetal

Reduced chain elongation *

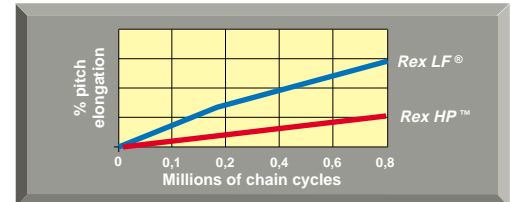

New technology virtually eliminates break-in stretch and reduces elongation due to wear. Through extensive testing, Rexnord has achieved the optimum design to minimize break-in wear while maximizing overall performance.

Lowest available friction *

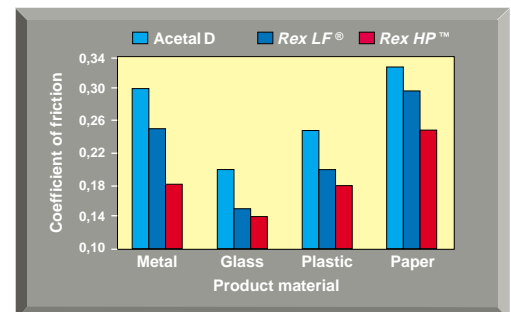

* = Graph shows comparative results at high-speed, dry operation.

Rex-LF®

Acetal Low Friction

Rex LF® is a mixture of acetal based resins. Improves mechanical characteristics and guarantees longer life in heavy duty conditions.

Operating temperatures:
in air (- 40°C a + 80°C)
in hot water (+ 65°C)

Inflammability: 94 HB.

Colour: LF (brown), WLF (white).

AS

Conductive resin

Good electrical conductivity.

Reduces the accumulation of electrostatic charges.

Lower mechanical characteristics.

Load carrying capacity is 40% lower than Rex LF®.

Operating temperatures:
in air (+ 60°C)
in hot water (+ 50°C)

Inflammability: 94 HB.

Colour: black.

It is recommended to always consult Rexnord prior to selection and design.

WPP

Reinforced polypropylene chemical agents resistant

Offers a mechanical resistance 20% higher than ordinary PP polypropylene.

Has a higher dimensional stability (the chain flatness characteristics are enhanced).

Operating temperatures:
in air (+ 5°C a + 115°C)
in hot water (+ 115°C)

Inflammability 94 HB.

Colour: white

It is recommended to always consult Rexnord prior to selection and design.

WRB

Wear resistant resin

To be used in abrasive environments (casting, machined steel components, sand, glass, sugar).

It offers a wear life 5 times longer than acetal resin.

The mechanical characteristics are similar to those of acetal resin.

The chain is not suitable to be used in wet environments. Must use oil lubricants.

Operating temperatures:
in air (- 5°C a + 100°C)

Inflammability: 94 HB.

Colour: black.

WX

Wear resistant resin

Exclusive material with aramid fibers.

Abrasion resistant chain in WX material.

Five times longer wear life compared to WRB chains. Lower coefficient of friction compared to WRB chains.

Dry running recommended.

Operating temperatures:
in air (+110°C)

Inflammability: 94 HB.

Colour: light green.

PC

Polycarbonate

Highly resistant to impact and to high temperatures.

Maintains its rigidity and other mechanical characteristics up to 130°C.

Operating temperatures:
in air (+130°C)

Inflammability: 94 V-2.

Colour: grey.

Thermoplastic sprockets

PA

Polyamide

High resistance to wear and impact.
Excellent dimensional stability even in relatively high temperatures.
Good resistance to chemicals.
Operating temperatures:
in air (0°C a + 80°C)
in hot water (+ 65°C)
Inflammability: 94 HB.
Colour: black.

PA FV

Reinforced polyamide

Offers a better resistance to wear and to impact than PA resin. Has a higher dimensional stability.
Offers an increased operating temperature.
Operating temperatures:
in air (- 5°C a + 120°C)
in hot water (+ 100°C)
Inflammability: 94 HB.
Colour: black.

Glistamide®

Special resin

Compared with polyamide PA it offers increased mechanical characteristics, better wear resistance and reduced coefficient of friction.
Operating temperatures:
in air (- 5°C a + 80°C)
in hot water (+ 90°C)
Inflammability: 94 V-2.
Colour: black.

Rubbers

PUR

Thermoplastic rubber

Hardness 90 Shore A.
High wear resistance.
Operating temperatures:
in air (- 40°C a + 100°C)
in hot water (+ 60°C)
Colour: dark grey.

SEBS

SEBS

Thermoplastic rubber

Available in two hardness types:
45 Shore A (white)
60 Shore A (light grey)
The lower hardness type has increased anti-slip properties, but reduced wear resistance.
Operating temperatures:
in air (- 40°C a + 100°C)

NBR

Nitrile rubber

Hardness 60 Shore A.
Operating temperatures:
in air (- 35°C a + 100°C)
Colour: black.

EPDM

Rubber

Hardness 40 Shore A.
Operating temperatures:
in air (- 50°C a + 150°C)
Colour: black.

Certification FDA & USDA

FDA

American institute (Food and Drug Administration), responsible for the certification of materials to be in contact with food.
For direct contact with food the following materials have been approved:

- AISI 304
- **Rex -HP™ Rex -WLF®**

USDA

United States Department of Agriculture, responsible for the approval of components and machinery in the meat, poultry and dairy industries.

The following chains have been approved :
843, 845, 963, 879, 879TAB, 880, 880TAB, 882TAB, 1843, 1873, 2873, 3873, 1700, 1701, 1702.

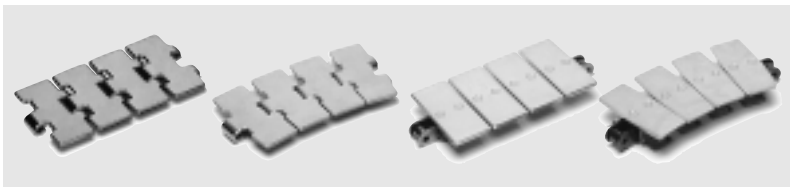

Steel TableTop® and Plate Top Chains

page 8 / 13

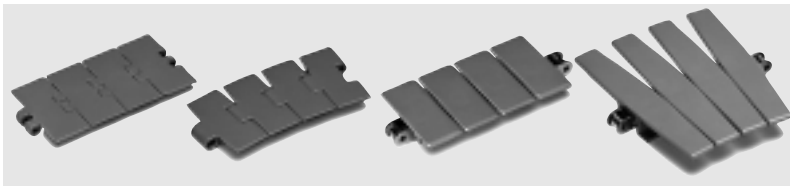

Thermoplastic TableTop® and Plate Top Chains

page 14 / 27

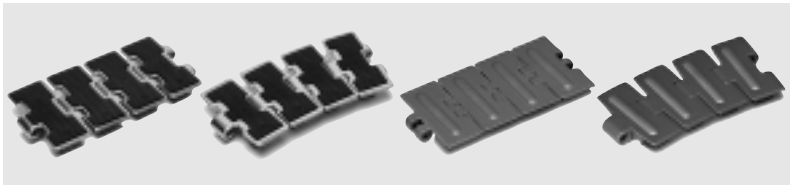

Chains for Incline Conveying

page 28 / 35

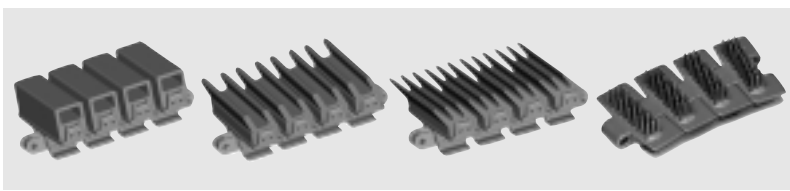

Gripper Chains

page 36 / 41

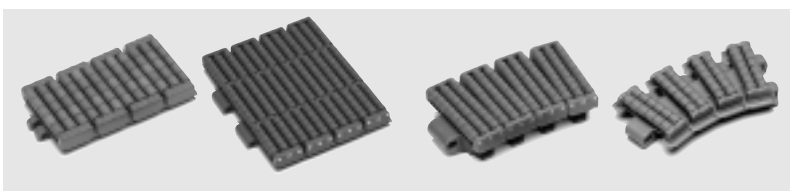

Low Backline Pressure Chains

page 42 / 45

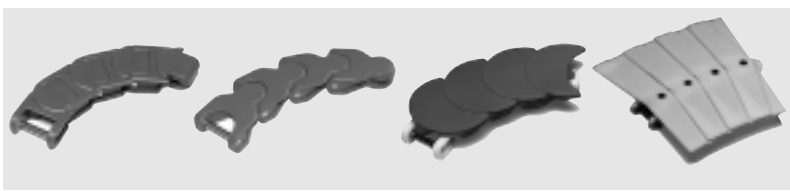

Multiflex Chains

page 46 / 55

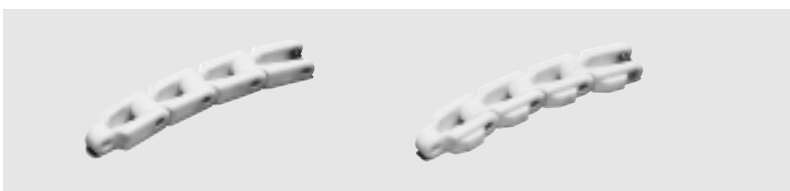

Case Conveyor Chains

page 56 / 57

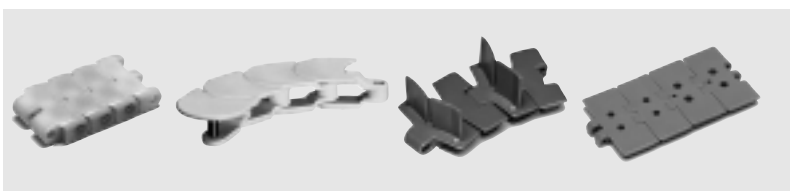

Special Chains

page 58 / 61



Sprockets and Idler Wheels Corner Tracks and Straight Tracks

page 62 / 95



Engineering Manual

page 96 / 119



Steel TableTop[®] and Plate Top Chains

Rex - **OPTI-Plus**[®] Chains

- *exclusive heat treated material*
- *improved ground surface finish*
- *reduced gap*
- *improved all around flatness*
- *improved harder pin material*
- *high wear resistance*
- *higher working load*
- *longer life and better product handling*

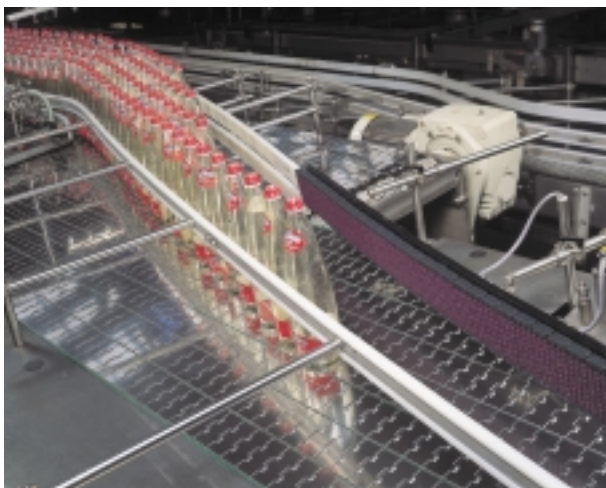

Steel TableTop® Chains

Straight Running

Steel TableTop® chains are especially suitable for:

- bottle transport (bottles in all shapes and sizes!)
- parts handling like bearings or gears

The above are just a few examples. Rexnord steel TableTop® chains can transport virtually anything!

Double hinge TableTop® chains, for especially high demands with regard to

- strength
- wear resistance

Rex - OPTI-Plus® = 40% higher strength, ground finish

Straight Running: Single Hinge, 38.1mm \triangleq 1½" Pitch

Rexnord Chain No.	Finish μm	Plate Material	Width K mm	Plate Gap G mm	Radius min. Rd mm	Weight kg/m
S815-K325*	0,6	Carbon Steel Heat Treated	82,5	1,8	150	2,6
S815-K450			114,3			3,3
S815-K750			190,5			5,1
SS812-K325	0,6	Stainless Steel Material No. 1.4016	82,5	2,8	75	2,6
SSR812-K325	0,5	Rex - OPTI-Plus®	82,5	2,8	75	2,6
SSX812-K325	0,3		82,5	2,8	75	2,6
SSY812-K350	0,3		88,9	1,6	150	2,7
SSC812-K250	0,5		63,5	1,6	150	2,4
SSC812-K263*			66,8			2,4
SSC812-K300*			76,2			2,5
SSC812-K325			82,5			2,6
SSC812-K330*			83,8			2,6
SSC812-K350			88,9			2,7
SSC812-K400			101,6			3,0
SSC812-K450			114,3			3,3
SSC812-K600			152,4			4,2
SSC812-K750			190,5			5,1
SS815-K325*	0,5	Austenitic Steel Chrom Nickel 18/8	82,5	1,6	150	2,6
SS815-K400*			101,6			3,0
SS815-K450*			114,3			3,3
SS815-K600*			152,4			4,2
SS815-K750*			190,5			5,1

* = Available upon request and minimum order quantity.
Pin material for S 815: case hardened steel.
Pin material for SS 815: stainless steel AISI 304.
Pin material for all other chains: stainless steel AISI 431.
Standard length: 80 pitches 10 ft (3.048 m)

See page 63/64/65

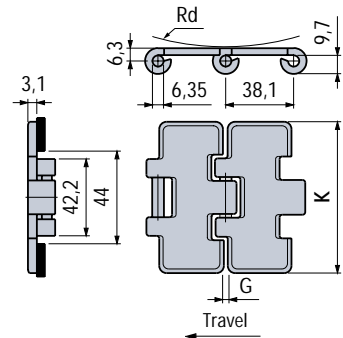
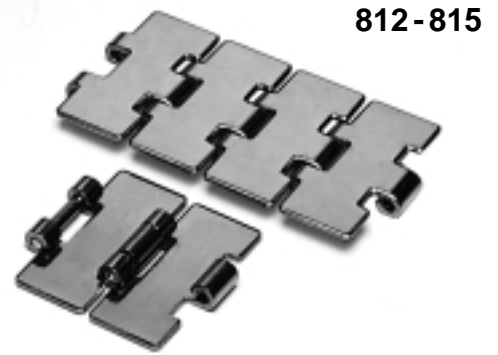

Straight Running: Double Hinge, 38.1 mm \triangleq 1½" Pitch

Rexnord Chain No.	Finish μm	Plate Material	Width K mm	Plate Gap G mm	Radius min. Rd mm	Weight kg/m
SS802-K750	0,6	Stainless Steel Material No. 1.4016	190,5	1,6	150	5,8
SSC802-K750	0,5	Rex - OPTI-Plus®	190,5	1,6	150	
SSC805 A-K750	0,5	Austenitic Steel Chrom Nickel 18/8	190,5	1,6	150	

Pin material for SSC 805: stainless steel AISI 304.
Pin material for all other chains: stainless steel AISI 431.
Standard length: 80 pitches 10 ft (3.048 m)

See page 66/67

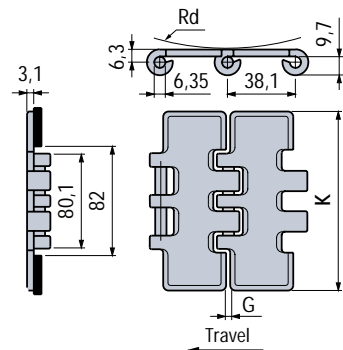

Series 512. Chains with one inch pitch are recommended for all applications involving the transport of small-sized products. A further advantage is their compact design.

Steel TableTop[®] Chains

Straight Running

SSR 812 - K 125/175

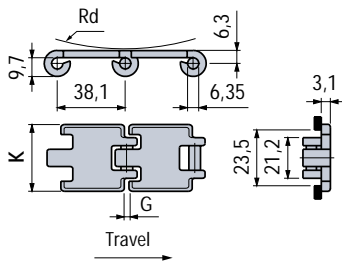

Rex - OPTI-Plus[®] = 40% higher strength, ground finish

Straight Running: Single Hinge, 38.1mm \triangleq 1 1/2" Pitch, Narrow Design

Rexnord Chain No.	Finish μm	Plate Material	Width K mm	Plate Gap G mm	Radius min. Rd mm	Weight kg/m
SSR 812 - K 125 SSR 812 - K 175	0,5	Rex - OPTI-Plus[®]	32,0 44,5	3,2	75	1,1 1,3

Pin material: stainless steel AISI 431.
Standard length: 80 pitches 10 ft (3.048 m)

See page 68/69



512

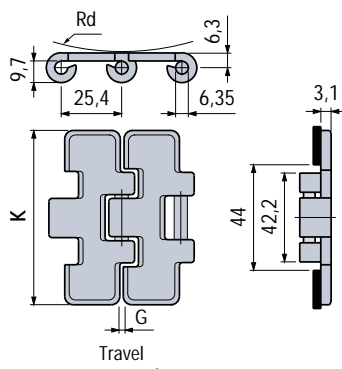

Straight Running: Single Hinge, 25.4mm \triangleq 1" Pitch

Rexnord Chain No.	Finish μm	Plate Material	Width K mm	Plate Gap G mm	Radius min. Rd mm	Weight kg/m
SSC 512 - K 217 SSC 512 - K 236 SSC 512 - K 250 SSC 512 - K 283 SSC 512 - K 325 SSC 512 - K 350 SSC 512 - K 400	0,5	Rex - OPTI-Plus[®]	55,0 60,0 63,5 72,0 82,5 88,9 101,6	1,6	100	2,29 2,41 2,49 2,65 2,86 3,01 3,26

Pin material: stainless steel AISI 431.
Standard length: 120 pitches 10 ft (3.048 m)

See page 67



Steel TableTop[®] Chains

Sideflexing

The higher demands placed on modern high-performance lines with regard to efficiency, safety and noise reduction led logically to the development of a new generation of sideflexing chains for:

- chains with bevelled guide shoes
- chains with hold-down tabs.

Its flatness and surface quality with circumferential chamfer as well as its distortion-free welding make this chain especially suitable for pressureless combiners.

The altered position and design of the hold-down tabs produce a self-cleaning effect and considerable increased stability.

Rex - OPTI-Plus[®] = 40% higher strength, ground finish

8811

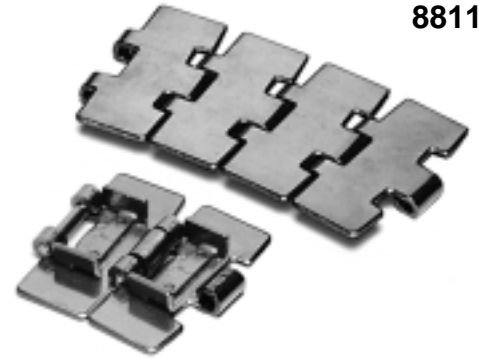

Sideflexing: Single Hinge, 38.1mm \triangle 1 1/2" Pitch

Rexnord Chain No.	Finish μm	Plate Material	Width K mm	Radius min. R mm	GC Straight Curve mm mm	Weight kg/m
SSC8811-K325	0,5	Rex - OPTI-Plus[®]	82,5	500	44,5 41,4	2,9
SSC8811-K350*			88,9	500		3,1
SSC8811-K450*			114,3	500		3,6
SSC8811-K750			190,5	500		5,3
SSX8811-K325*	0,3		82,5	500		2,9

* = Available upon request and minimum order quantity.
Pin material: stainless steel AISI 431.

Standard length: 80 pitches 10 ft (3.048 m)

See page 87



See page 68/69

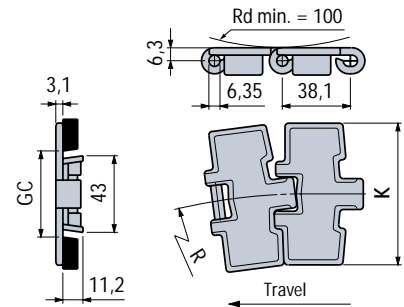

8811 TAB



Sideflexing: Single Hinge, 38.1mm \triangle 1 1/2" Pitch

Rexnord Chain No.	Finish μm	Plate Material	Width K mm	Radius min. R mm	GC Straight Curve mm mm	Weight kg/m
SSC8811TAB-K325	0,5	Rex - OPTI-Plus[®]	82,5	500	46 44,2	3,1
SSC8811TAB-K350*			88,9	500		3,3
SSC8811TAB-K450			114,3	500		3,8
SSC8811TAB-K750			190,5	500		5,5
SSX8811TAB-K325	0,3		82,5	500		3,1

* = Available upon request and minimum order quantity.
Pin material: stainless steel AISI 431.

Standard length: 80 pitches 10 ft (3.048 m)

See page 89



See page 68/69

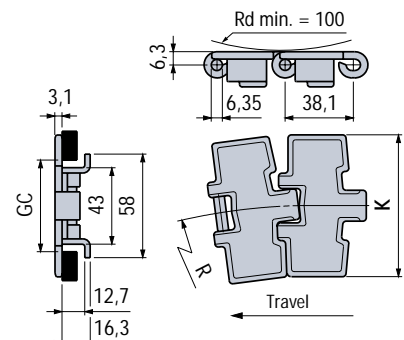

Steel TableTop[®] Chains

Sideflexing

8811 BO

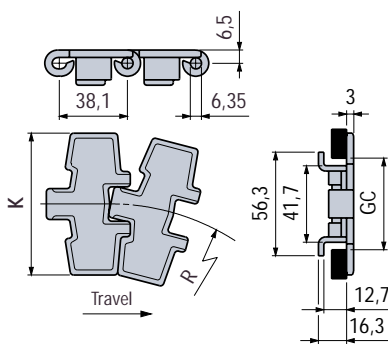

Rex - OPTI-Plus[®] = 40% higher strength, ground finish

Radius min. = 200

Sideflexing: Single Hinge, 38.1mm \triangle 1 1/2" Pitch

Rexnord Chain No.	Finish μm	Plate Material	Width K mm	Radius min. R mm	GC Straight Curve mm mm	Weight kg/m
SSR 8811 BO-K325	0,5	Rex - OPTI-Plus[®]	82,5	200	46 44,2	3,1

Pin material: stainless steel AISI 431.
Standard length: 80 pitches 10 ft (3.048 m)

See page 68/69



881 M

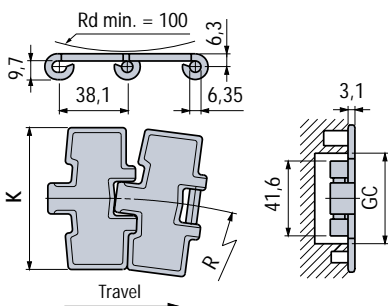

Magnetic System

Sideflexing: Single Hinge, 38.1mm \triangle 1 1/2" Pitch

Rexnord Chain No.	Finish μm	Plate Material	Width K mm	Radius min. R mm	GC Straight Curve mm mm	Weight kg/m
SSC 881 M-K325	0,5	Rex - OPTI-Plus[®]	82,5	500	45 44,2	2,5
SSC 881 M-K450			114,3	500		3,2
SSC 881 M-K750			190,5	500		4,9
SSX 881 M-K325	0,3		82,5	500		2,5

Pin material: stainless steel AISI 431.
Standard length: 80 pitches 10 ft (3.048 m)

See page 91



See page 63/64/65



Plate Top Chains

With Steel Top Plates

Series 1864. Plate top chains with steel top plates are especially suitable for heavy loads, long distances and high speeds. The chain consists of a base roller chain with steel plates welden on. Similarly to the TableTop® chains, various steel alloys are available for the plates. The gap between the plates is 1,6 mm wide.

Series 1874 TAB. The sideflexing plate top chain utilizes the advantage of a precision built base roller chain with "snap on" top plates to form a continuous flat conveying surface. Hold-down tabs are used to provide positive retention in curves and inclines.

Straight Running

Straight Running: Steel and Stainless Steel Top Plates, 19.05mm \triangleq 3/4" Pitch

Rexnord Chain No.	Material		Width K mm	Weight kg/m
	Base Chain	Top Plate		
1864-K325 1864-K450	Steel	Steel	82,5 114,3	3,33 4,0
1864A-K325 1864A-K450*	Steel	Stainless Steel	82,5 114,3	3,33 4,0
1864SS-K325* 1864SS-K450	Stainless Steel	Stainless Steel	82,5 114,3	3,33 4,0

* = Available upon request and minimum order quantity.
Standard length: 160 pitches 10 ft (3.048 m)

Standard ANSI 60

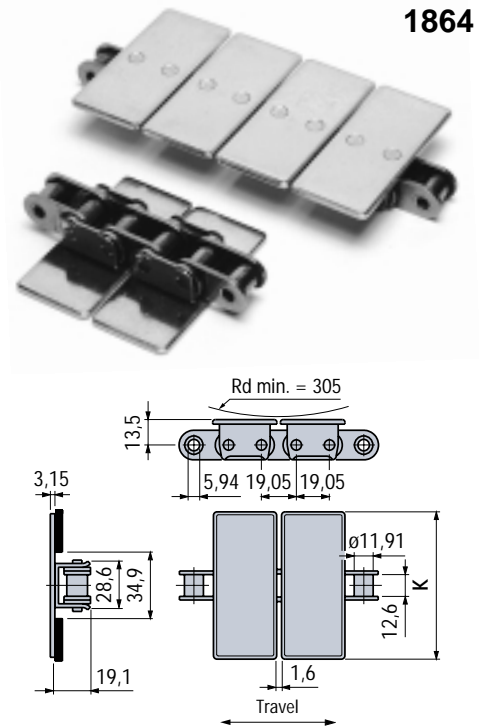

Sideflexing

Sideflexing: Steel and Stainless Steel Top Plates, 19.05 mm \triangleq 3/4" Pitch

Rexnord Chain No.	Material		Width K mm	Radius min. R mm	GC		Weight kg/m
	Base Chain	Top Plate			Straight mm	Curve mm	
1874TAB-K325 1874TAB-K450 1874TAB-K600 1874TAB-K750	Steel	Steel	82,5 114,3 152,4 190,5	381 381 457 610	34,1	34,6	4,2 4,8 5,7 6,4
1874TABSS-K325 1874TABSS-K450 1874TABSS-K600 1874TABSS-K750	Stainless Steel	Stainless Steel	82,5 114,3 152,4 190,5	381 381 457 610	34,1	34,6	4,2 4,8 5,7 6,4

Standard length: 160 pitches 10 ft (3.048 m)

See page 93



Standard ANSI 60

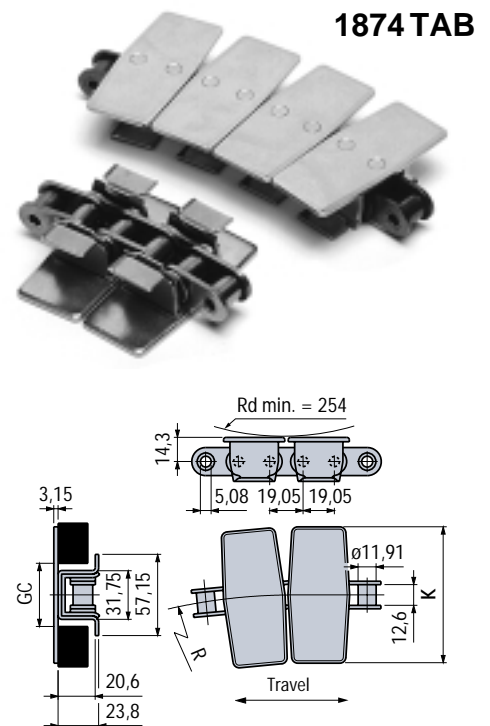



Thermo- plastic TableTop[®] and Plate Top Chains

Rex-HP™ Chains

- lowest friction coefficient of any chain material
- 40% longer flight wear life than plain acetal
- 25% longer flight wear life than **Rex-LF**[®] acetal
- reduced chain wear elongation
- reduced product backline pressure
- lower horsepower requirements



Thermoplastic TableTop® Chains

Straight Running

Thermoplastic TableTop® chains are especially suitable for transporting sensitive products such as cans, cartons, or PET bottles.

These chains are distinguished by their low noise level, as there are no metal-to-metal contacts.

Plastic pins also available upon request with minimum order quantity, for LF and WPP chains. Code: LF 820-K...-C.

820 chains also available in acetal grey upon request and minimum order quantity.

820

Rex - HP™ = High Performance

Plate thickness 4 mm



Straight Running: Single Hinge, 38.1mm \triangleq 1 1/2" Pitch

Rexnord Chain No.	Plate Material	Width K mm	Thickness TT mm	h mm	Weight kg/m
LF 820-K250 LF 820-K325 LF 820-K343* LF 820-K350 LF 820-K400 LF 820-K450 LF 820-K600 LF 820-K750	Rex - LF® (Brown)	63,5 82,5 87 88,9 101,6 114,3 152,4 190,5	4	9,5	0,73 0,83 0,85 0,87 0,95 1,03 1,25 1,47
HP 820-K325 HP 820-K343 HP 820-K350 HP 820-K400 HP 820-K450 HP 820-K600 HP 820-K750	Rex - HP™ (Dark grey)	82,5 87 88,9 101,6 114,3 152,4 190,5	4	9,5	0,83 0,85 0,87 0,95 1,03 1,25 1,47
AS 820-K325* AS 820-K350* AS 820-K400* AS 820-K450* AS 820-K600* AS 820-K750*	Anti-static AS (Black)	82,5 88,9 101,6 114,3 152,4 190,5	4	9,5	0,83 0,87 0,95 1,03 1,25 1,47
WRB 820-K325 WRB 820-K450 WRB 820-K750*	Wear resistant WRB (Black)	82,5 114,3 190,5	4	9,5	0,83 1,03 1,47
WX 820-K325 WX 820-K450	Wear resistant WX (Light green)	82,5 114,3	4	9,5	0,83 1,03
WPP 820-K325* WPP 820-K350* WPP 820-K400* WPP 820-K450* WPP 820-K600* WPP 820-K750*	Reinforced polypropylene WPP** chemical resistant (White)	- - - - - -	-	-	0,70 0,74 0,82 0,90 1,05 1,20

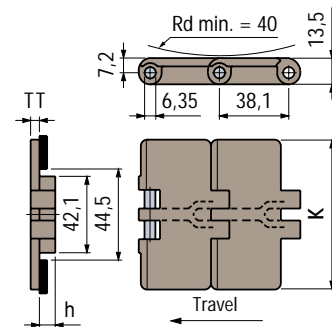

* = Available upon request and minimum order quantity.

Pin material: wear resistant stainless steel.

Only for WPP 820: reinforced polypropylene (on request in stainless steel AISI 316).

** = WPP chain dimensions are larger than those indicated in the drawing. For certified dimensions refer to our Technical Department. Ask for Rexnord assistance for the use of sprockets.

Standard length: 80 pitches 10 ft (3.048 m)

See
page 70/71



The design of links allows overlapping of top plates, thus creating a flat and continuous surface.

Series 831: Differs from the 820 series in the greater thickness of plates (4,8 mm). Wear life increased by 40%.

Allows flush installation side by side of chain series:

821, 879, 879 TAB, 882 TAB.

821 chains also available in acetal grey upon request and minimum order quantity.

Thermo-plastic TableTop Chains[®]

Straight Running

831



Rex-HP™ = High Performance

Plate thickness 4,8 mm

Straight Running: Single Hinge, 38.1 mm \triangleq 1 1/2" Pitch

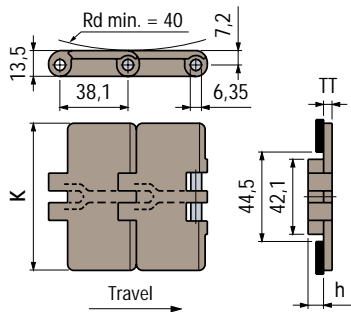

Rexnord Chain No.	Plate Material	Width	Thickness		Weight kg/m
		K mm	TT mm	h mm	
LF831-K325 LF831-K450 LF831-K750*	Rex-LF[®] (Brown)	82,5 114,3 190,5	4,8	8,7	1,00 1,24 1,76
HP831-K325 HP831-K450* HP831-K750*	Rex-HP™ (Dark grey)	82,5 114,3 190,5	4,8	8,7	1,00 1,24 1,76

* = Available upon request and minimum order quantity.
Pin material: wear resistant stainless steel.
Standard length: 80 pitches 10 ft (3.048 m)

See page 70/71 

821

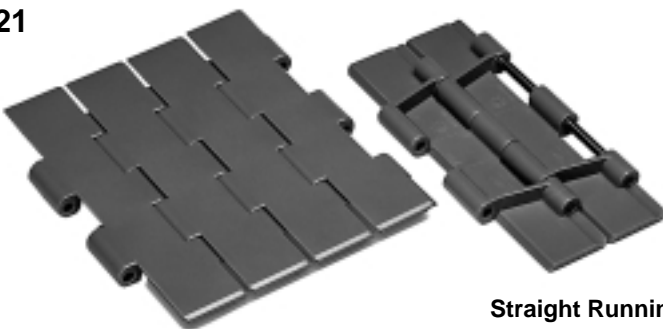

Straight Running: Double Hinge, 38.1 mm \triangleq 1 1/2" Pitch

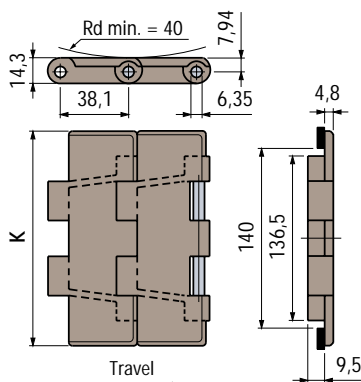

Rexnord Chain No.	Plate Material	Width	Weight
		K mm	kg/m
LF821 K 750 LF821 K1000 LF821 K1200	Rex-LF[®] (Brown)	190,5 254 304,8	2,50 2,95 3,25
HP821 K 750 HP821 K1000 HP821 K1200*	Rex-HP™ (Dark grey)	190,5 254 304,8	2,50 2,95 3,25

* = Available upon request and minimum order quantity.
Pin material: wear resistant stainless steel.
Standard length: 80 pitches 10 ft (3.048 m)

See page 72/73 

Thermo- plastic TableTop® Chains

Sideflexing

Chain equipped with side holding system "BEVEL" type on curved runs. Can be lifted on straight runs for cleaning and maintenance. No possibility of jamming of broken glass.

Series 879: Differs from the 880 series in the greater thickness of plates (4.8 mm). Wear life increased by 40%.

Allows flush installation side by side of chain series: 831, 821.

Plastic pins also available upon request with minimum order quantity, for LF 880.

Rex - HP™ = High Performance

Plate thickness 4 mm

Sideflexing: Single Hinge, 38.1mm \triangleq 1 1/2" Pitch

Rexnord Chain No.	Plate Material	Width			Radius min. R mm	GC		Weight kg/m
		K mm	TT mm	h mm		Straight mm	Curve mm	
LF 880-K325 LF 880-K450	Rex - LF® (Brown)	82,5 114,3	4	16	457 500	44,5	41,4	0,89 1,04
HP 880-K325 HP 880-K450*	Rex - HP™ (Dark grey)	82,5 114,3	4	16	457 500	44,5	41,4	0,89 1,04
WRB 880-K325 WRB 880-K450	Wear resistant WRB (Black)	82,5 114,3	4	16	457 500	44,5	41,4	0,89 1,04
WX 880-K325 WX 880-K450	Wear resistant WX (Light green)	82,5 114,3	4	16	457 500	44,5	41,4	0,89 1,04

* = Available upon request and minimum order quantity.
Pin material: wear resistant stainless steel.
Standard length: 80 pitches 10 ft (3.048 m)

See page 87



See page 74/75

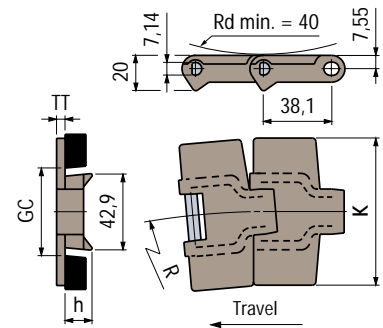

Plate thickness 4,8 mm

Sideflexing: Single Hinge, 38.1mm \triangleq 1 1/2" Pitch

Rexnord Chain No.	Plate Material	Width			Radius min. R mm	GC		Weight kg/m
		K mm	TT mm	h mm		Straight mm	Curve mm	
LF 879-K325* LF 879-K450	Rex - LF® (Brown)	82,5 114,3	4,8	15,2	457 610	44,5	41,4	0,93 1,10

* = Available upon request and minimum order quantity.
Pin material: wear resistant stainless steel.
Standard length: 80 pitches 10 ft (3.048 m)

See page 74/75

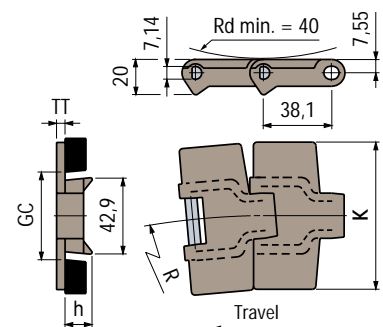

Chain equipped with "TAB" type side holding system on curved runs. Positive holding capability, allows higher speed and greater loads. TAB type guides offer also positive holding of the chain onto the runners during return travel.

Series LF and HP 880TAB-K343. The width of 87 mm, allows the design of multiple strand conveyors with gaps of 1 mm (instead of 5,5 mm).

Old conveyors can be adapted for the conveying of PET bottles with petaloid bottom, by simply changing the chains and chain guides.

Plastic pins also available upon request with minimum order quantity, for LF 880 TAB.

Series 879 TAB. Differs from type 880TAB for the greater plate thickness (4,8 mm). Wear life increased by 40%. Allows side by side installation of chains type 831, 821, 882 TAB.

Thermo-plastic TableTop® Chains

Sideflexing

880 TAB

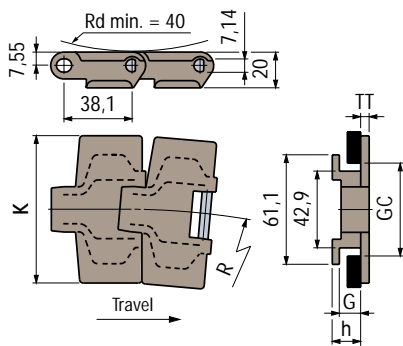
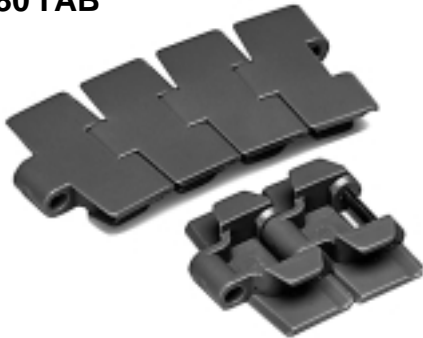

Rex-HP™ = High Performance

Plate thickness 4 mm

Sideflexing: Single Hinge, 38.1mm \triangleq 1 1/2" Pitch

Rexnord Chain No.	Plate Material	Width				Radius min. R mm	GC		Weight kg/m
		K mm	TT mm	G mm	h mm		Straight mm	Curve mm	
LF 880 TAB-K 250	Rex-LF® (Brown)	63,5				457			0,80
LF 880 TAB-K 325		82,5				457			0,94
LF 880 TAB-K 343*		87	4	11,5	16	500	46	44,2	0,99
LF 880 TAB-K 350		88,9				500			1,01
LF 880 TAB-K 450		114,3				500			1,08
HP 880 TAB-K 325	Rex-HP™ (Dark grey)	82,5				500			0,94
HP 880 TAB-K 343*		87	4	11,5	16	500	46	44,2	0,99
HP 880 TAB-K 450		114,3				500			1,08
AS 880 TAB-K 325	Anti-static AS (Black)	82,5				500			0,94
AS 880 TAB-K 450		114,3	4	11,5	16	500	46	44,2	1,08
WRB 880 TAB-K 325	Wear resistant WRB (Black)	82,5				500			0,94
WRB 880 TAB-K 450		114,3	4	11,5	16	500	46	44,2	1,08
WX 880 TAB-K 325	Wear resistant WX (Light green)	82,5				500			0,94
WX 880 TAB-K 450		114,3	4	11,5	16	500	46	44,2	1,08

* = Available upon request and minimum order quantity.
Pin material: wear resistant stainless steel.
Standard length: 80 pitches 10 ft (3.048 m)

See page 89



See page 74/75



879 TAB

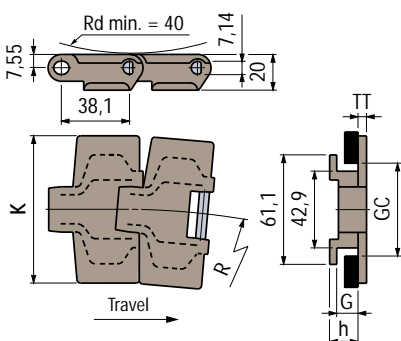

Plate thickness 4,8 mm

Sideflexing: Single Hinge, 38.1mm \triangleq 1 1/2" Pitch

Rexnord Chain No.	Plate Material	Width				Radius min. R mm	GC		Weight kg/m
		K mm	TT mm	G mm	h mm		Straight mm	Curve mm	
LF 879 TAB-K 325	Rex-LF® (Brown)	82,5	4,8	11	15,2	457			0,98
LF 879 TAB-K 450		114,3				610	46	44,2	1,14
HP 879 TAB-K 325*	Rex-HP™ (Dark grey)	82,5	4,8	11	15,2	457			0,98
HP 879 TAB-K 450*		114,3				610	46	44,2	1,14

* = Available upon request and minimum order quantity.
Pin material: wear resistant stainless steel.
Standard length: 80 pitches 10 ft (3.048 m)

See page 89



See page 74/75



Thermo-plastic TableTop® Chains

Sideflexing

Series 880BO. It differs from the 880TAB by having a smaller curving radius (R min. = 190 mm). The use of lateral corner wheels allows compact layouts and greater number of curves. It is recommended for layouts which require greater variety of configurations (buffer areas) and for pallet conveying for the mechanical and automotive industries.

Series 879BO. Small sideflexing radius (R min. = 190 mm). Tangential sprocket. Small gap, better product support. Conveyors with many corners are possible, compact dimensions, alpine accumulation systems, flat carousel conveyors. Bidirectional.



Radius min. = 190

Sideflexing: Single Hinge, 38.1mm \triangleq 1 1/2" Pitch

Rexnord Chain No.	Plate Material	Width K mm	Radius min. R mm	GC		Weight kg/m
				Straight mm	Curve mm	
LF880BO-K325 LF880BO-K450*	Rex-LF® (Brown)	82,5 114,3	190	46	44,2	0,96 1,11

* = Available upon request and minimum order quantity.
Pin material: wear resistant stainless steel.
Standard length: 80 pitches 10 ft (3.048 m)

See
page 83



See
page 74/75

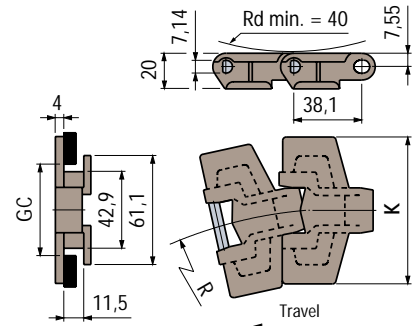

Radius min. = 190

Sideflexing: Single Hinge, 38.1mm \triangleq 1 1/2" Pitch

Rexnord Chain No.	Plate Material	Width K mm	Radius min. R mm	GC		Weight kg/m
				Straight mm	Curve mm	
LF879BO-K325 LF879BO-K450	Rex-LF® (Brown)	82,5 114,3	190	46	44,2	1,08 1,20

Pin material: wear resistant stainless steel.
Standard length: 80 pitches 10 ft (3.048 m)

See
page 83



See
page 74/75

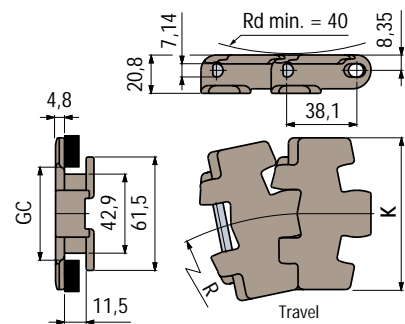

Optimum product stability. Superior product handling through curves. Long life. Self adjusting chain clearance for trapped debris. High strength and heavy-duty flight design. Easy installation, cleaning and maintenance. Use of magnetic corner tracks.

Thermo-plastic TableTop® Chains

Sideflexing

FGM 1050



Rex-HP™ = High Performance

Magnetic System
Plate thickness 8,7 mm

Sideflexing: Single Hinge, 25.4 mm \triangle 1" Pitch

Rexnord Chain No.	Plate Material	Width K mm	Radius min. R mm	GC		Weight kg/m
				Straight mm	Curve mm	
FGM1050HP-K330	Rex-HP™ (Dark grey)	83,8	500	44	44	1,54

Pin material: stainless steel.
Standard length: 120 pitches 10 ft (3.048 m)

See page 92



See page 78

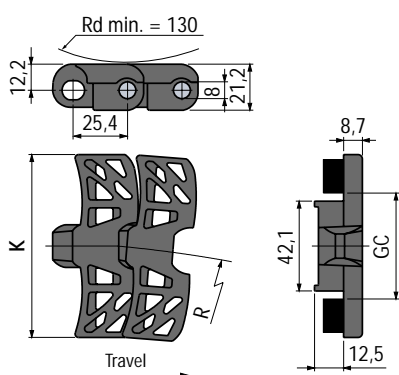

FTM 1050



Magnetic System
Plate thickness 8,7 mm

Sideflexing: Single Hinge, 25.4 mm \triangle 1" Pitch

Rexnord Chain No.	Plate Material	Width K mm	Radius min. R mm	GC		Weight kg/m
				Straight mm	Curve mm	
FTM1050HP-K330	Rex-HP™ (Dark grey)	83,8	500	44	44	1,54

Pin material: stainless steel.
Standard length: 120 pitches 10 ft (3.048 m)

See page 92



See page 78

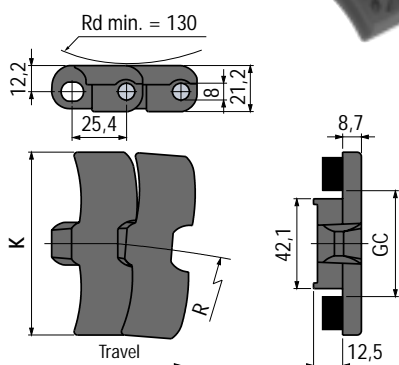

Thermo- plastic TableTop[®] Chains

Sideflexing

Optimum product stability. Superior product handling through curves. Long life. Self adjusting chain clearance for trapped debris. High strength and heavy-duty flight design. Easy installation, cleaning and maintenance. Use of magnetic corner tracks. Can be used in combination with Rex[®] 7700 (same thickness).

Rex - HP[™] = High Performance

Magnetic System
Plate thickness 12,7 mm

Sideflexing: Single Hinge, 25.4 mm \triangle 1" Pitch

Rexnord Chain No.	Plate Material	Width K mm	Radius min. R mm	GC		Weight kg/m
				Straight mm	Curve mm	
FTM1055HP-K330	Rex - HP[™] (Dark grey)	83,8	500	44	44	1,54

Pin material: stainless steel.
Standard length: 120 pitches 10 ft (3.048 m)

See page 92



See page 78

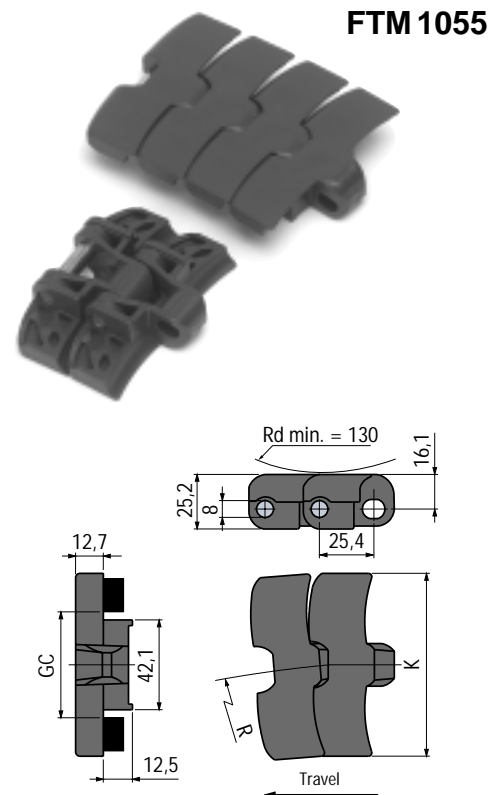

Series 880 MG. Easy installation, cleaning and maintenance. Standard conveyor construction. Low friction HP material. Longer wear life. Magnetic corner design. Optimum product handling.

Series 880TAB-K454. The base chain is similar to series 880TAB except for the side flaps which act as guide for the product transported.

Thermo-plastic TableTop Chains[®]

Sideflexing

880 MG

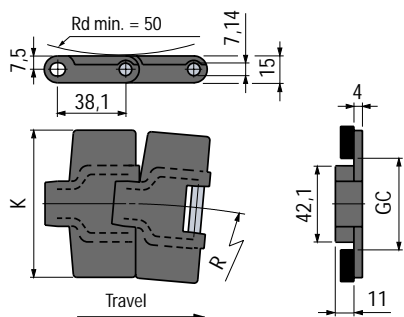

Rex-HP[™] = High Performance

Magnetic System

Sideflexing: Single Hinge, 38.1mm \triangleq 1 1/2" Pitch

Rexnord Chain No.	Plate Material	Width K mm	Radius min. R mm	GC		Weight kg/m
				Straight mm	Curve mm	
HP880MG-K325	Rex-HP[™] (Dark grey)	82,5	457	44	44	1,03

Pin material: stainless steel.
Standard length: 80 pitches 10 ft (3.048 m)

See page 91



See page 74/75



880TAB-K454

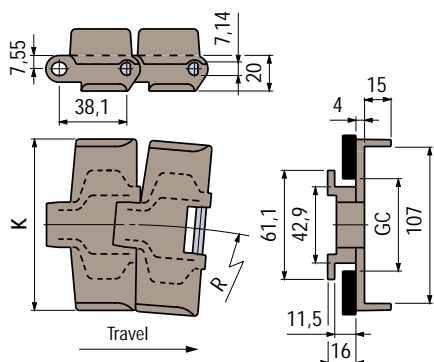

Sideflexing: Single Hinge, 38.1mm \triangleq 1 1/2" Pitch

Rexnord Chain No.	Plate Material	Width K mm	Radius min. R mm	GC		Weight kg/m
				Straight mm	Curve mm	
LF880TAB-K454	Rex-LF[®] (Brown)	115,3	610	46	44,2	1,12

Pin material: wear resistant stainless steel.
Standard length: 80 pitches 10 ft (3.048 m)

See page 89



See page 74/75



Thermo- plastic TableTop[®] Chains

Sideflexing

Series RR 882. The base chain is similar to the 882TAB except for the stiffening ridges which permit the use of transfer combs. It is recommended for end of run head transfer where the use of dead plates may create product stability problems.

RR 882

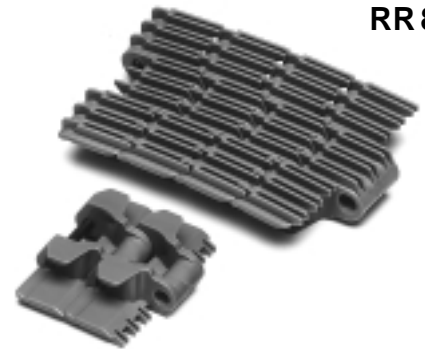

Sideflexing: Single Hinge, 38.1mm \triangle 1 1/2" Pitch

Rexnord Chain No.	Plate Material	Width K mm	Radius min. R mm	GC		Weight kg/m
				Straight mm	Curve mm	
RR 882TAB-K450*	Rex-LF[®] (Brown)	114,3	610	60	58	2,40

* = Available upon request and minimum order quantity.

Pin material: wear resistant stainless steel.

Standard length: 80 pitches 10 ft (3.048 m)

See
page 90



See
page 76/77

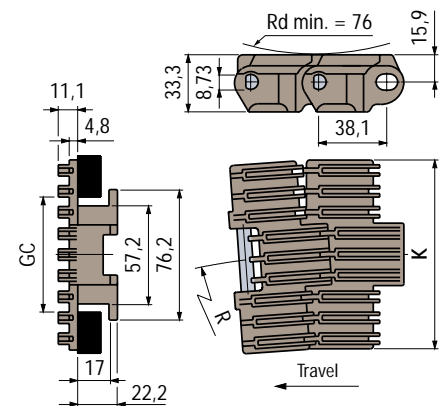
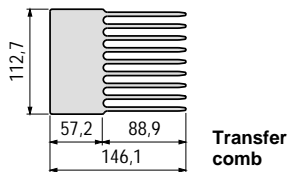

Series 882 chains are heavy-duty TableTop® chains with a level of performance equivalent to that of the stainless steel TableTop® chain 8811.

They are designed to convey larger and heavier products over longer distances.

This chain is available in both versions, i.e. with hold-down tabs and bevelled guide shoes.

Thermo-plastic TableTop® Chains

Sideflexing

882

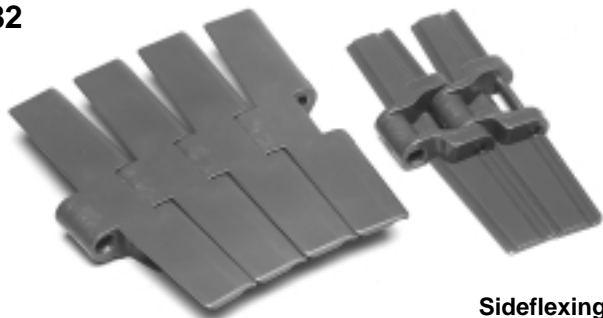

Sideflexing: Single Hinge, 38.1mm \triangle 1 1/2" Pitch

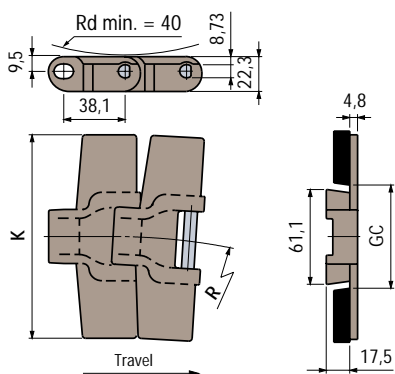

Rexnord Chain No.	Plate Material	Width K mm	Radius min. R mm	GC		Weight kg/m
				Straight	Curve	
LF882-K 450*	Rex-LF® (Brown)	114,3	610	61,9	58	1,94
LF882-K 750		190,5				2,38
LF882-K1000*		254				2,83

* = Available upon request and minimum order quantity.

Pin material: wear resistant stainless steel.

Standard length: 80 pitches 10 ft (3.048 m)

See page 88



See page 76/77



882 TAB

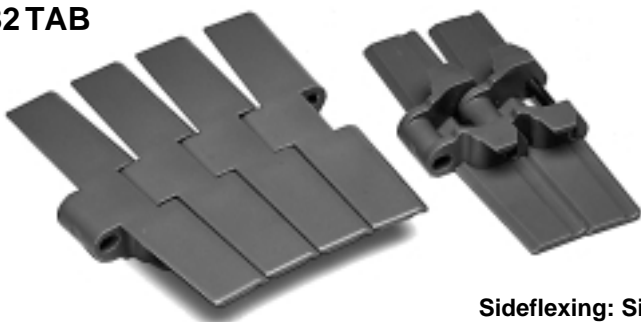

Rex-HP™ = High Performance

Sideflexing: Single Hinge, 38.1mm \triangle 1 1/2" Pitch

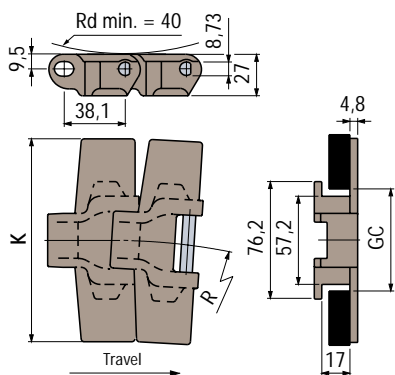

Rexnord Chain No.	Plate Material	Width K mm	Radius min. R mm	GC		Weight kg/m
				Straight	Curve	
LF882TAB-K 325	Rex-LF® (Brown)	82,5	610	60	58	1,86
LF882TAB-K 450*		114,3				1,98
LF882TAB-K 450*		114,3				1,98
LF882TAB-K 750		190,5				2,43
LF882TAB-K1000		254				2,87
LF882TAB-K1200		304,8				3,41
HP882TAB-K 325	Rex-HP™ (Dark grey)	82,5	610	60	58	1,86
HP882TAB-K 450*		114,3				1,98
HP882TAB-K 450*		114,3				1,98
HP882TAB-K 750		190,5				2,43
HP882TAB-K1000		254				2,87
HP882TAB-K1200		304,8				3,41

* = Available upon request and minimum order quantity.

Pin material: wear resistant stainless steel.

Standard length: 80 pitches 10 ft (3.048 m)

See page 90



See page 76/77



Plate Top Chains

With Thermoplastic Top Plates

Straight Running

A roller chain ANSI 40 (pitch 12,7 mm) is used as base chain. The top plates (which are replaceable) are clipped on the protruding pins.

They have a greater loading capacity, permit higher speed and longer runs with a single power traction unit. The small pitch reduces the sagging effect and permits the use of smaller sprockets. They are recommended for step-to-step positioning.

Series 843. Uni-directional travel.

Series 845. They differ from the 843 due the bevelling of the plate edges, which facilitate longitudinal and lateral movements. Bi-directional travel.

It is particularly recommended for conveying the new 202 type tins.



843

Straight Running: Thermoplastic Top Plates, 12.7 mm \triangleq 1/2" Pitch

Rexnord Chain No.	Material		Width K mm	Weight kg/m
	Base Chain	Top Plate		
LF843-K138 LF843-K144* LF843-K200 LF843-K275* LF843-K325*	Steel	Rex-LF® (Brown)	34,9 36,5 50,8 70 82,5	0,83 0,84 0,89 0,92 1,03
LF843SS-K138 LF843SS-K144* LF843SS-K200 LF843SS-K275* LF843SS-K325*	Stainless Steel	Rex-LF® (Brown)	34,9 36,5 50,8 70 82,5	0,83 0,84 0,89 0,92 1,03

* = Available upon request and minimum order quantity.
Standard length: 240 pitches 10 ft (3.048 m)

Standard ANSI 40

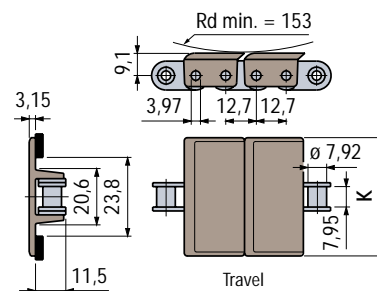

845

Straight Running: Thermoplastic Top Plates, 12.7 mm \triangleq 1/2" Pitch

Rexnord Chain No.	Material		Width K mm	Weight kg/m
	Base Chain	Top Plate		
LF845-K118* LF845-K138 LF845-K200*	Steel	Rex-LF® (Brown)	28,6 34,9 50,8	0,85 0,89 0,99
LF845SS-K118* LF845SS-K138* LF845SS-K200*	Stainless Steel	Rex-LF® (Brown)	28,6 34,9 50,8	0,85 0,89 0,99

* = Available upon request and minimum order quantity.
Standard length: 240 pitches 10 ft (3.048 m)

Standard ANSI 40

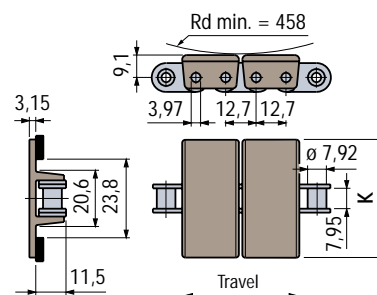

They have a greater loading capacity, allow higher speeds and longer runs with single power traction units. They are indicated for step by step positioning.

Quieter gearing operation. The top plates are clipped on the protruding pins of the chain and are replaceable.

Series 963. A roller chain ANSI 60 (pitch 19,05 mm) is used as base chain. The Top plates are designed for overlapping. The continuous surface facilitate stability and ease operations with unstable products. Uni-directional travel.

Series 1843. The base chain is a standard roller chain Side Bow ANSI 40 SB (pitch 12,7 mm). The small pitch reduces the sagging effect and permits the use of smaller sprockets. Uni-directional travel.

Plate Top Chains

With Thermoplastic Top Plates

Straight Running

963

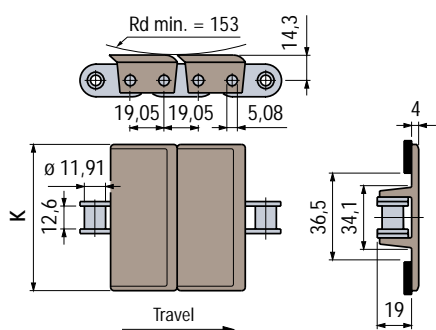

Straight Running: Thermoplastic Top Plates, 19.05 mm \triangleq 3/4" Pitch

Rexnord Chain No.	Material		Width K mm	Weight kg/m
	Base Chain	Top Plate		
LF963-K325*	Steel	Rex-LF[®] (Brown)	82,5	2,10
LF963-K450*			114,3	2,23
LF963-K600*			152,4	2,53
LF963-K750*			190,5	2,68
LF963SS-K325*	Stainless Steel	Rex-LF[®] (Brown)	82,5	2,10
LF963SS-K450*			114,3	2,23
LF963SS-K600*			152,4	2,53
LF963SS-K750*			190,5	2,68

* = Available upon request and minimum order quantity.

Standard length: 160 pitches 10 ft (3.048 m)

Standard ANSI 60



1843

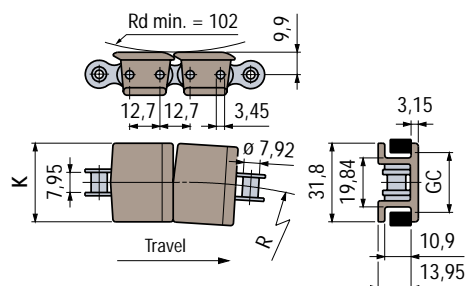

Sideflexing

Sideflexing: Thermoplastic Top Plates, 12.7 mm \triangleq 1/2" Pitch

Rexnord Chain No.	Material		Width K mm	Radius min. R mm	GC		Weight kg/m
	Base Chain	Top Plate			Straight mm	Curve mm	
LF1843TAB-K125	Steel	Rex-LF[®] (Brown)	31,8	254	21,3	22,3	0,74
LF1843TAB-K200			50,8				0,90

Standard length: 240 pitches 10 ft (3.048 m)

Standard ANSI 40



Plate Top Chains

With Thermoplastic Top Plates

Sideflexing

They have a greater loading capacity, allow higher speeds and longer runs with single power traction units. They are indicated for step by step positioning.

The top plates are clipped on the protruding pins of the chain and are replaceable.

Series 1873. The base chain is a roller chain Side Bow 63 SB (pitch 19,05 mm). Bi-directional travel.

PC 1873 chains are recommended for glued rubber inserts (inclined runs).

Series 3873. The "snap on" overlapping plastic top plates form a continuous surface, even in tight radius.

The base chains can be supplied either in stainless steel or carbon steel.



Sideflexing: Thermoplastic Top Plates, 19.05 mm \triangleq 3/4" Pitch

Rexnord Chain No.	Material		Width K mm	Radius min. R mm	GC		Weight kg/m
	Base Chain	Top Plate			Straight	Curve	
LF1873TAB-K 325 LF1873TAB-K 450* LF1873TAB-K 600 LF1873TAB-K 750 LF1873TAB-K 1000 LF1873TAB-K 1200	Steel	Rex-LF® (Brown)	82,5 114,3 152,4 190,5 254 304,8	356 356 457 457 457 610	33,3	34,6	2,1 2,3 2,4 2,6 2,8 3,0
LF1873TABSS-K 325 LF1873TABSS-K 450 LF1873TABSS-K 600 LF1873TABSS-K 750 LF1873TABSS-K 1000 LF1873TABSS-K 1200	Stainless Steel	Rex-LF® (Brown)	82,5 114,3 152,4 190,5 254 304,8	356 356 457 457 457 610	33,3	34,6	2,1 2,3 2,4 2,6 2,8 3,0
PC1873TAB-K 450	Steel	Polycarbonate (Grey)	114,3	356	33,3	34,6	2,3
PC1873TABSS-K 450	Stainless Steel	Polycarbonate (Grey)	114,3	356	33,3	34,6	2,3
WRB1873TAB-K 325 WRB1873TAB-K 450*	Steel	Wear resistant WRB (Black)	82,5 114,3	356 356	33,3	34,6	2,1 2,3
WX1873TAB-K 450	Steel	Wear resistant WX (Light green)	114,3	356	33,3	34,6	2,3

* = Available upon request and minimum order quantity.

On request: PC K600, K750, K1000 (both steel and stainless steel base chain)

Standard length: 160 pitches 10 ft (3.048 m)

See page 93



Standard ANSI 60

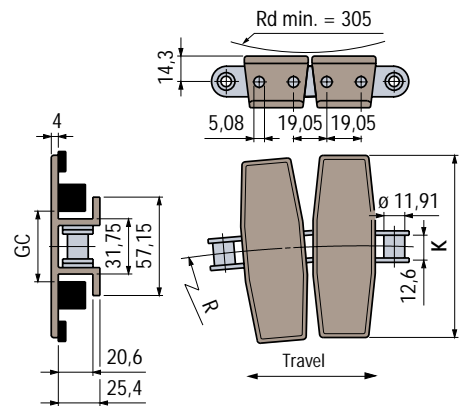

3873 TAB

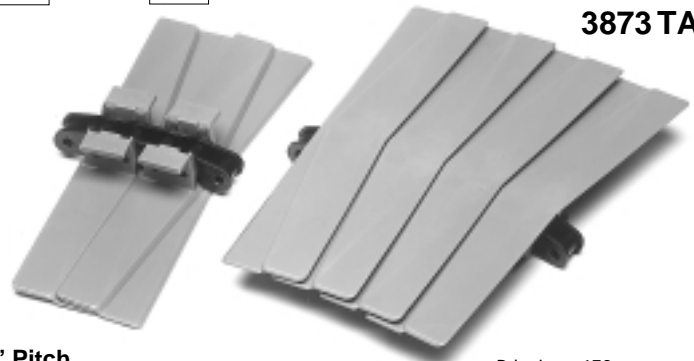

Sideflexing: Thermoplastic Top Plates, 19.05 mm \triangleq 3/4" Pitch

Rexnord Chain No.	Material		Width K mm	Radius min. R mm	GC		Weight kg/m
	Base Chain	Top Plate			Straight	Curve	
LF3873TAB-K 1000*	Steel	Rex-LF® (Brown)	254	457	33,3	34,6	3,1
LF3873TABSS-K 1000*	Stainless Steel						
WPC3873TAB-K 1200*	Steel	Polycarbonate (White)	304,8	610	33,3	34,6	3,2
WPC3873TABSS-K 1200*	Stainless Steel						

* = Available upon request and minimum order quantity.

Standard length: 160 pitches 10 ft (3.048 m)

Standard ANSI 60

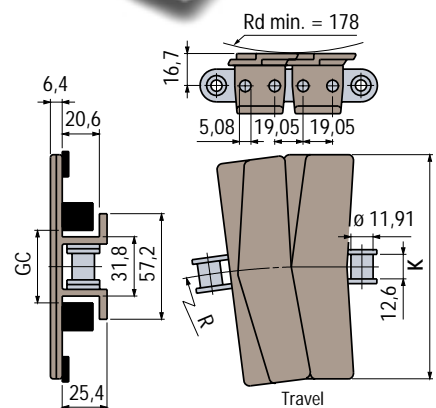

Chains for Incline Conveying



- for inclines up to 25 degrees
- rigid design
- positive guiding system



Steel TableTop® Chains

With Rubber Top

TableTop® chains with vulcanized rubber coating make it possible to transport products which tend to slide easily. Robust design for longer life and heavy duty applications.

Rex - OPTI-Plus® = 40% higher strength, ground finish

Straight Running: Single Hinge, 38.1mm \triangleq 1 1/2" Pitch

Rexnord Chain No.	Plate Material	Width K mm	Plate Gap G mm	Radius min. Rd mm	Weight kg/m
SSR 812-K325 Rubber Top	Rex - OPTI-Plus®	82,5	2,8	75	2,8

Pin material: wear resistant stainless steel
Antislip insert material: NR rubber (black)
70 Shore A hardness.

Standard length: 80 pitches 10 ft (3.048 m)

See page 63/64/65



SSR 812

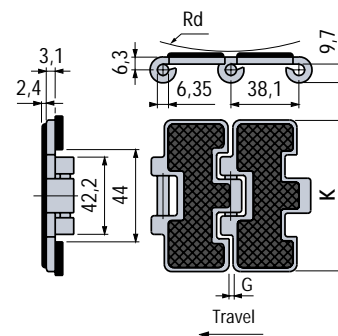

Straight Running: Single Hinge, 38.1mm \triangleq 1 1/2" Pitch

Rexnord Chain No.	Plate Material	Width K mm	Plate Gap G mm	Radius min. Rd mm	Weight kg/m
SSR 812TAB-K325 Rubber Top	Rex - OPTI-Plus®	82,5	2,8	75	3,4

Pin material: wear resistant stainless steel
Antislip insert material: NR rubber (black)
70 Shore A hardness.

Standard length: 80 pitches 10 ft (3.048 m)

See page 89



See page 68/69



SSR 812TAB

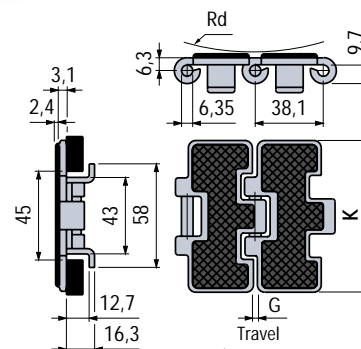

TableTop® chains with vulcanized rubber coating make it possible to transport products which tend to slide easily. Robust design for longer life and heavy duty applications. Through the use of the guide shoe concept, goods may be conveyed directly from straight running to incline and also around corners.

Steel TableTop® Chains

With Rubber Top

Rex - OPTI-Plus® = 40% higher strength, ground finish

SSC 802

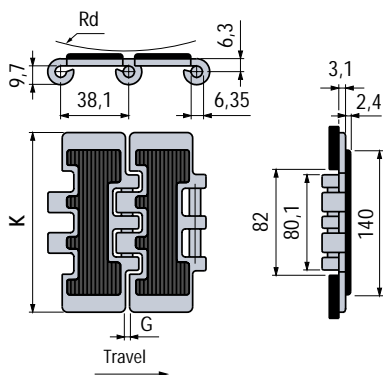
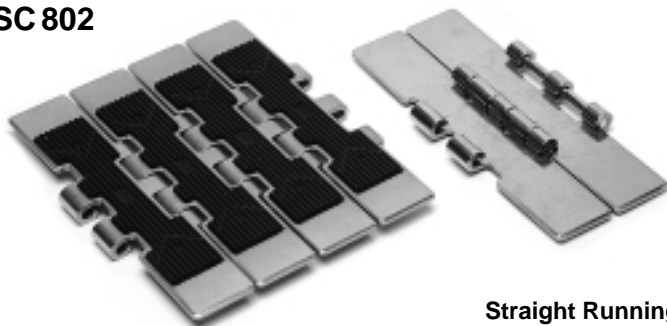

Straight Running: Double Hinge, 38.1 mm \triangleq 1 1/2" Pitch

Rexnord Chain No.	Plate Material	Width K mm	Plate Gap G mm	Radius min. Rd mm	Weight kg/m
SSC802-K750 Rubber Top	Rex - OPTI-Plus®	190,5	1,6	150	6,2

Pin material: wear resistant stainless steel
 Antislip insert material: NR rubber (black)
 70 Shore A hardness.
 Standard length: 80 pitches 10 ft (3.048 m)

See page 66/67



SSC 8811 TAB

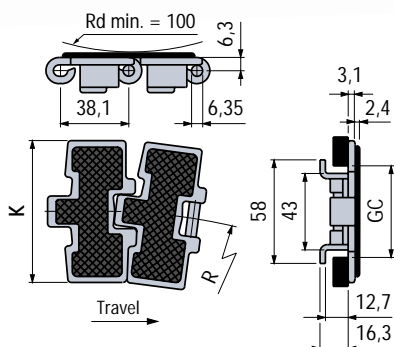

Sideflexing: Single Hinge, 38.1mm \triangleq 1 1/2" Pitch

Rexnord Chain No.	Plate Material	Width K mm	Radius min. R mm	GC Straight Curve mm mm	Weight kg/m
SSC 8811 TAB-K325 Rubber Top	Rex - OPTI-Plus®	82,5	500	46 44,2	3,3

Pin material: wear resistant stainless steel
 Antislip insert material: NR rubber (black)
 70 Shore A hardness.
 Standard length: 80 pitches 10 ft (3.048 m)

See page 89



See page 68/69



Thermo- plastic TableTop® Chains

With Rubber Inserts

The thermoplastic TableTop® chains with rubber insert, series HFP, have rubber inserts moulded into the topplates. These chains are suitable for conveyors with an inclination up to 25°, depending on the conveyed product.



HFP 820

Straight Running: Single Hinge, 38.1mm \triangleq 1 1/2" Pitch

Rexnord Chain No.	Material		Width K mm	A mm	Weight kg/m
	Link	Antislip insert			
HFP 820-K 325*	Rex-LF® (Brown)	SEBS rubber (light grey) 60 Shore A	82,5	65,0	0,83
HFP 820-K 350*			88,9	88,9	0,87
HFP 820-K 400*			101,6	101,6	0,95
HFP 820-K 450*			114,3	114,3	1,03
HFP 820-K 600*			152,4	135,0	1,25

* = Available upon request and minimum order quantity.
Pin material: stainless steel.

On request: Antislip insert in:

SEBS rubber (white), 45 Shore A hardness.

PUR rubber (dark grey), 90 Shore A hardness.

Chains series K 350, K 400, K 450 are obtained by cutting the K 600 series.

Standard length: 80 pitches 10 ft (3.048 m)

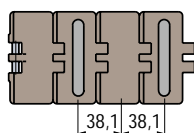

Special configurations on request. Indicate the distance between inserts at the time of ordering.

See page 70/71 

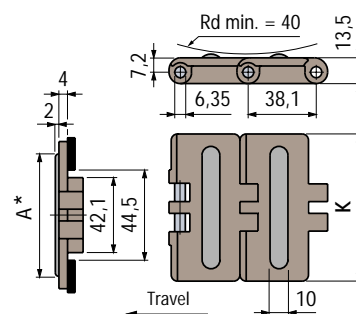

* = For chain series K 350, K 400, K 450, the width A is equal to K.



HFP 821

Straight Running: Double Hinge, 38.1 mm \triangleq 1 1/2" Pitch

Rexnord Chain No.	Material		Width K mm	A mm	Weight kg/m
	Link	Antislip insert			
HFP 821-K 750*	Rex-LF® (Brown)	SEBS rubber (light grey) 60 Shore A	190,5	132	2,50
HFP 821-K 1000*			254	195	2,95
HFP 821-K 1200*			304,8	245	3,25

* = Available upon request and minimum order quantity.
Pin material: stainless steel.

On request: Antislip insert in:

SEBS rubber (white), 45 Shore A hardness.

PUR rubber (dark grey), 90 Shore A hardness.

Standard length: 80 pitches 10 ft (3.048 m)

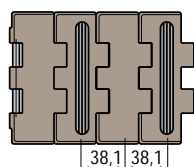

Special configurations on request. Indicate the distance between inserts at the time of ordering.

See page 72/73 

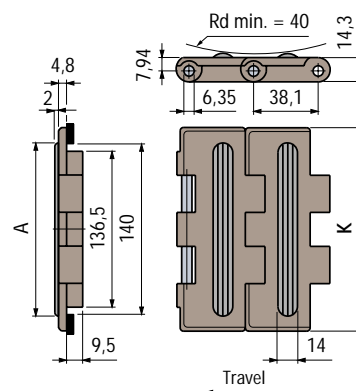

The thermoplastic TableTop® chains with rubber inserts, series HFP, are also available in sideflexing execution. This make them suitable for applications with curves and installations with horizontal and inclined sections.

Thermoplastic TableTop® Chains

With Rubber Inserts

HFP 880 TAB

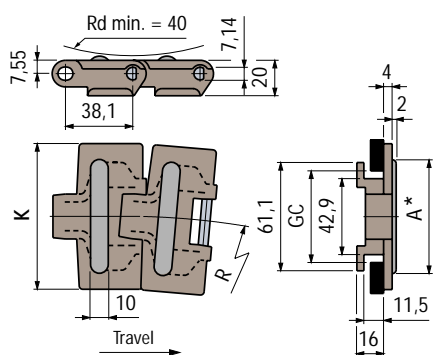

* = For chain series K240 the width A is equal to K.

Sideflexing: Single Hinge, 38.1mm \triangle 1 1/2" Pitch

Rexnord Chain No.	Material		Width K mm	A mm	Radius min. R mm	GC		Weight kg/m
	Link	Antislip insert				Straight	Curve	
HFP880TAB-K240*	Rex-LF® (Brown)	SEBS rubber (light grey)	61	61	457	46	44,2	0,70
HFP880TAB-K325*		SEBS rubber (light grey)	82,5	65	457			0,94
HFP880TAB-K450*		60 Shore A	114,3	95	500			1,08

* = Available upon request and minimum order quantity.
Pin material: stainless steel.

On request: Antislip insert in:

SEBS rubber (white), 45 Shore A hardness.

PUR rubber (dark grey), 90 Shore A hardness.

Chains series K240 is obtained by cutting K325 series.

Standard length: 80 pitches 10 ft (3.048 m)

See page 89



See page 74/75

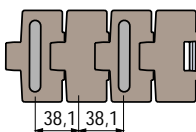

Special configurations on request. Indicate the distance between inserts at the time of ordering.

HFP 880 BOT

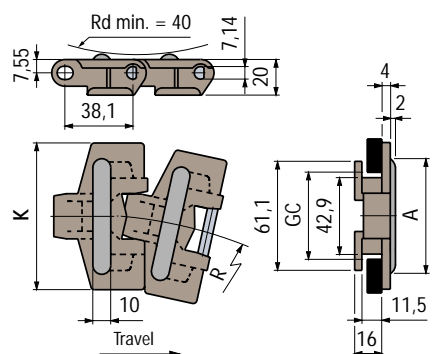

Radius min. = 190

Sideflexing: Single Hinge, 38.1mm \triangle 1 1/2" Pitch

Rexnord Chain No.	Material		Width K mm	A mm	Radius min. R mm	GC		Weight kg/m
	Link	Antislip insert				Straight	Curve	
HFP880BOT-K325*	Rex-LF® (Brown)	SEBS rubber (light grey)	82,5	65	190	46	44,2	0,96
		60 Shore A						

* = Available upon request and minimum order quantity.
Pin material: stainless steel.

On request: Antislip insert in:

SEBS rubber (white), 45 Shore A hardness.

PUR rubber (dark grey), 90 Shore A hardness.

Standard length: 80 pitches 10 ft (3.048 m)

See page 83



See page 74/75

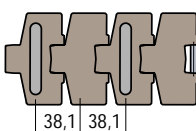

Special configurations on request. Indicate the distance between inserts at the time of ordering.

Thermo-plastic TableTop® Chains

With Rubber Inserts

The antislip insert fitted during moulding permits inclined conveying with grades up to 25°. The rubber used for the inserts has a hardness of 60 Shore A standard. Different hardness 45 or 90 Shore A are available on request. (Softer inserts have a greater gripping power but reduced wear resistance).

Series HFP 879 BO. The base chain is the one used for 879 BO series. Small sideflexing radius (R min. = 190 mm). Tangential sprocket. Small gap, better product support. Conveyors with many corners are possible, compact dimensions. Bidirectional.

Series HFP 882 TAB. The base chain is the one used for 882 TAB series.

HFP 879 BO



Sideflexing: Single Hinge, 38.1mm \triangle 1 1/2" Pitch

Rexnord Chain No.	Material		Width K mm	A mm	Radius min. R mm	GC		Weight kg/m
	Link	Antislip insert				Straight	Curve	
HFP 879 BO-K 325*	Rex-LF® (Brown)	SEBS rubber (light grey) 60 Shore A	82,5	71	190	46	44,2	1,08
HFP 879 BO-K 450*			114,3	102				1,20

* = Available upon request and minimum order quantity.
Pin material: stainless steel.

On request: Antislip insert in:

SEBS rubber (white), 45 Shore A hardness.

PUR rubber (dark grey), 90 Shore A hardness.

Standard length: 80 pitches 10 ft (3.048 m)

See
page 83



See
page 74/75

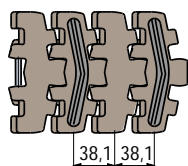
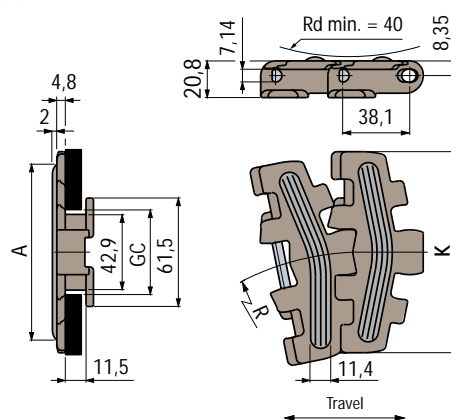

Special configurations
on request. Indicate the
distance between inserts
at the time of ordering.

HFP 882 TAB



Sideflexing: Single Hinge, 38.1mm \triangle 1 1/2" Pitch

Rexnord Chain No.	Material		Width K mm	A mm	Radius min. R mm	GC		Weight kg/m
	Link	Antislip insert				Straight	Curve	
HFP 882 TAB-K 750*	Rex-LF® (Brown)	SEBS rubber (light grey) 60 Shore A	190,5	132	610	60	58	2,43
HFP 882 TAB-K 1000*			254	195				2,87
HFP 882 TAB-K 1200*			304,8	246				3,41

* = Available upon request and minimum order quantity.
Pin material: stainless steel.

On request: Antislip insert in:

SEBS rubber (white), 45 Shore A hardness.

PUR rubber (dark grey), 90 Shore A hardness.

Standard length: 80 pitches 10 ft (3.048 m)

See
page 90



See
page 76/77

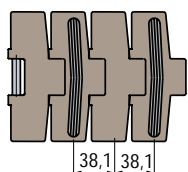
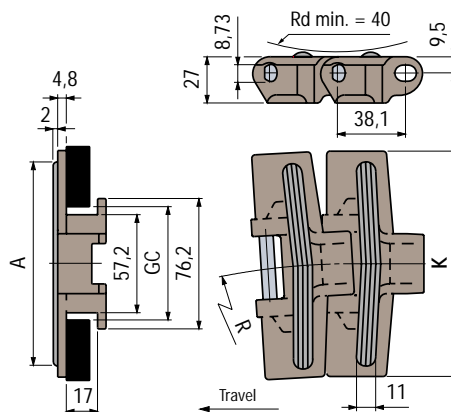

Special configurations
on request. Indicate the
distance between inserts
at the time of ordering.

The antislip insert fitted during moulding permits inclined conveying with grades up to 25°. The base chain is a standard roller chain Side Bow ANSI 63 SB (pitch 19,05 mm). The replaceable top plates are clipped on the protruding pins of the base chain. Longer runs can be designed with a single power traction unit. The TAB guides permit to continue either from an inclined run to a plane one or viceversa.

Plate Top Chains

With Thermoplastic Top Plates

With Rubber Inserts

HFP 1873 TAB

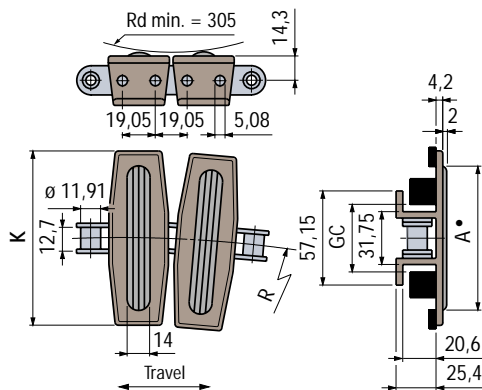
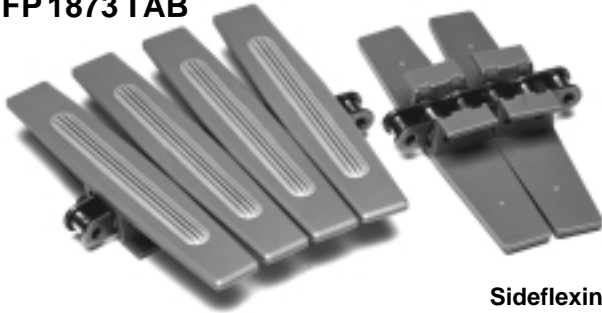

● = For chain series K325, K350, K375, K450, the width A is equal to K.

Sideflexing: Thermoplastic Top Plates, 19.05 mm \triangleq 3/4" Pitch

Rexnord Chain No.	Material		Width K mm	A mm	Radius min. R mm	GC		Weight kg/m
	Base Chain	Top Plate				Straight mm	Curve mm	
HFP1873TAB-K 325*	Steel	Rex-LF® (Brown)	82,5	82,5	457	33,3	34,6	2,60
HFP1873TAB-K 350*			88,9	88,9	457			2,65
HFP1873TAB-K 375*			95,2	95,2	457			2,70
HFP1873TAB-K 450*			114,3	114,3	457			2,80
HFP1873TAB-K 600*			152,4	132	457			2,90
HFP1873TAB-K 750*			190,5	132	457			3,10
HFP1873TAB-K1000*			254	195	457			3,40
HFP1873TAB-K1200*			304,8	245	610			3,60
HFP1873TABSS-K 325*	Stainless Steel	Rex-LF® (Brown)	82,5	82,5	457	33,3	34,6	2,60
HFP1873TABSS-K 350*			88,9	88,9	457			2,65
HFP1873TABSS-K 375*			95,2	95,2	457			2,70
HFP1873TABSS-K 450*			114,3	114,3	457			2,80
HFP1873TABSS-K 600*			152,4	132	457			2,90
HFP1873TABSS-K 750*			190,5	132	457			3,10
HFP1873TABSS-K1000*			254	195	457			3,40
HFP1873TABSS-K1200*			304,8	245	610			3,60

* = Available upon request and minimum order quantity.

Antislip insert material: **SEBS** rubber (light grey), 60 shore A hardness.

See page 93



Standard ANSI 60



On request: Antislip insert in:

SEBS rubber (white), 45 Shore A hardness.

PUR rubber (dark grey), 90 Shore A hardness.

Chains series K325, K350, K375, K450, K600 are obtained by cutting the K750 series.

Standard length: 160 pitches 10 ft (3.048 m)

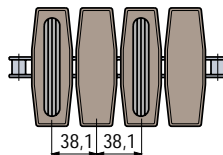

Special configurations on request. Indicate the distance between inserts at the time of ordering.

Thermo-plastic TableTop® Chains

With Pushers

Series HFP 821 F. The base chain is the same as for the 821 series. The rubber pusher fin insert is applied during the moulding process. The chain is recommended as a substitute for belt conveyors, thus eliminating all maintenance needs.

Series HFP 882 TAB F. The base chain is the same as for the 882 TAB series. The rubber pusher insert is applied during the moulding process.

HFP 821 F

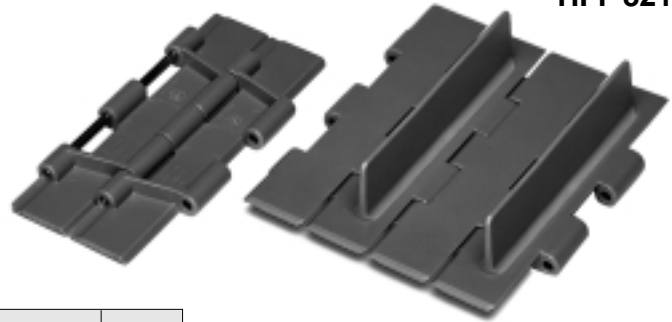

Straight Running: Double Hinge, 38.1 mm \triangle 1 1/2" Pitch

Rexnord Chain No.	Material		Width K mm	A mm	Weight kg/m
	Link	Pusher			
HFP 821-K 750 F*	Rex-LF® (Brown)	PUR rubber (dark grey) 90 Shore A	190,5	151	2,43
HFP 821-K 1000 F*			254	214	2,85
HFP 821-K 1200 F*			304,8	265	3,17

* = Available upon request and minimum order quantity.
Pin material: stainless steel.

Standard length: 80 pitches 10 ft (3.048 m)

See page 72/73

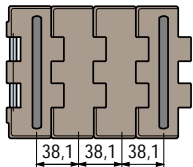

Special configurations on request. Indicate the distance between pushers at the time of ordering.

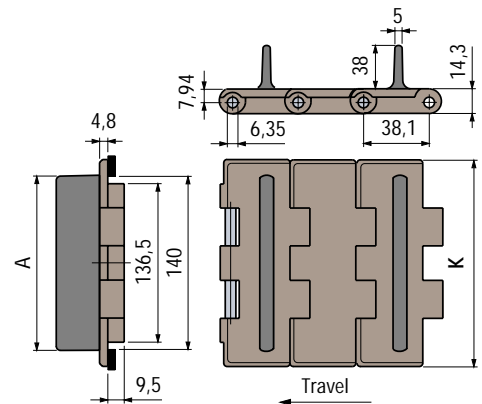

HFP 882 TAB F



Sideflexing: Single Hinge, 38.1mm \triangle 1 1/2" Pitch

Rexnord Chain No.	Material		Width K mm	A mm	Radius min. R mm	GC		Weight kg/m
	Link	Pusher				Straight mm	Curve mm	
HFP 882 TAB-K750 F*	Rex-LF® (Brown)	PUR rubber (dark grey) 90 Shore A	190,5	132	610	60	58	2,43

* = Available upon request and minimum order quantity.
Pin material: stainless steel.

Standard length: 80 pitches 10 ft (3.048 m)

See page 90



See page 76/77

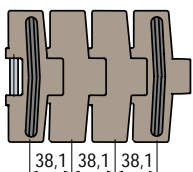

Special configurations on request. Indicate the distance between pushers at the time of ordering.

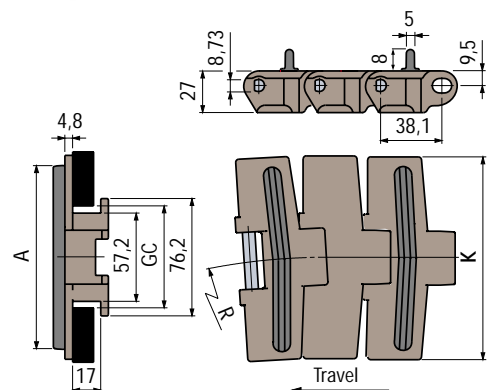

Gripper Chains



- to lift , to lower, to turn over (rinsing machines)
- for bottles, tins, jars, boxes, cartons, bundles, parcels, industrial components
- up to 60 mt/min. conveying speeds
- soft rubber gripper elements (to avoid product damaging)



Gripper Chains

Series 1874 G. Chains fitted with steel top plates to be used in abrasive and heavy duty conditions or in case of high temperatures. The base is a standard roller chain Side Bow ANSI 63 SB (pitch 19,06 mm). The gripper elements are available in the "GD" type (Smooth pad) and "GJ" (Grooved pad). They are clipped on and easily replaceable.

The clip for the TAB guide is welded on the top plate.

Series 1843 G. The thermoplastic top plates other than providing a quieter and smoother operation, make it possible to reduce the plant weight, increase conveying speed and permit dry service. The gripper elements are available in the "GD" type (Smooth pad) and "GJ" type (Grooved pad). They are clipped on and easily replaceable.

The base is a standard roller chain Side Bow ANSI 43 SB (pitch 12,7 mm). It is recommended for the conveying of ampoules, test tubes and other minute products such as small industrial components.

1874 G

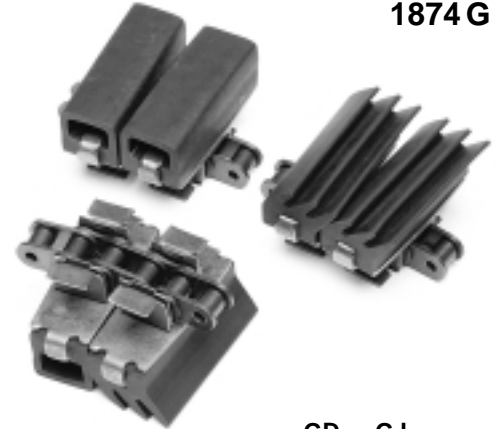

Sideflexing: Steel and Stainless Steel Top Plates, 19.05 mm \triangleq 3/4" Pitch

Rexnord Chain No.	Ultimate Strgth. N	Material		Width K mm	Radius min. R mm	GC		Weight kg/m
		Base Chain	Top Plate			Straight mm	Curve mm	
1874-K363GD 1874-K363GJ	27000	Steel	Steel	92,1	381	34,1	34,9	5,6
1874A-K363GD* 1874A-K363GJ*	27000	Steel	Stainless Steel	92,1	381	34,1	34,9	5,6
1874SS-K363GD 1874SS-K363GJ	21000	Stainless Steel	Stainless Steel	92,1	381	34,1	34,9	5,6

* = Available upon request and minimum order quantity.
EPDM rubber gripper elements (black).
50 shore A hardness.

White grippers available upon request.

Standard length: 160 pitches 10 ft (3.048 m)

See page 93



Standard ANSI 60

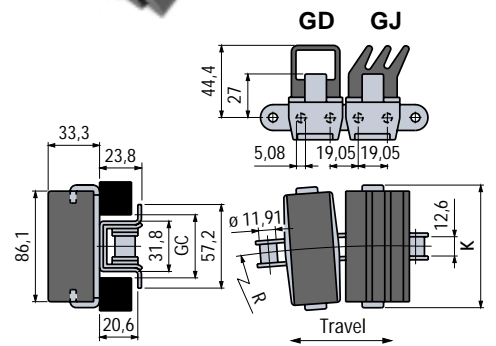

1843 G

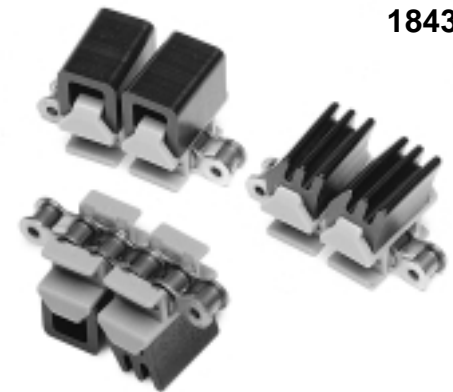

Sideflexing: Thermoplastic Top Plates, 12.7 mm \triangleq 1/2" Pitch

Rexnord Chain No.	Material		Width K mm	Radius min. R mm	GC		Weight kg/m
	Base Chain	Top Plate			Straight mm	Curve mm	
LF1843-K150GD* LF1843-K150GJ*	Steel	Rex-LF® (Brown)	38,1	254	21,4	22,2	1,2
LF1843SS-K150GD* LF1843SS-K150GJ*	Stainless Steel		38,1	254	21,4	22,2	1,2

* = Available upon request and minimum order quantity.
EPDM rubber gripper elements (black).
50 shore A hardness.

White grippers available upon request.

Standard length: 240 pitches 10 ft (3.048 m)

Standard ANSI 40

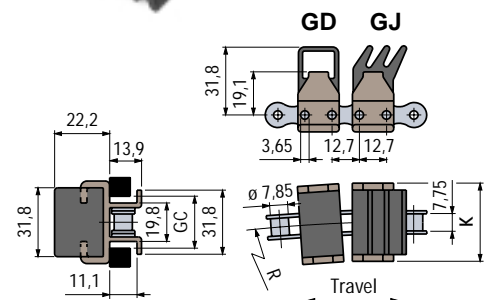

Gripper Chains

Series 1843 G. The thermoplastic top plates other than providing a quieter and smoother operation, make it possible to reduce the plant weight, increase conveying speed and permit dry service. The gripper elements are available in the "GD" type (Smooth pad) and "GJ" type (Grooved pad). They are clipped on and easily replaceable.

The base is a standard roller chain Side Bow ANSI 43 SB (pitch 12,7 mm). It is recommended for the conveying of ampoules, test tubes and other minute products such as small industrial components.

Series 1873 GS. New version available in 95,3 and 120 mm widths. New rubber gripper assembly system resistant to bending. High quality EPDM vulcanized gripper elements. Gripper available in different shapes and heights. HP™ material gives minimum friction. Bidirectional. Same accessories as chain 1873 Series.

1843 G

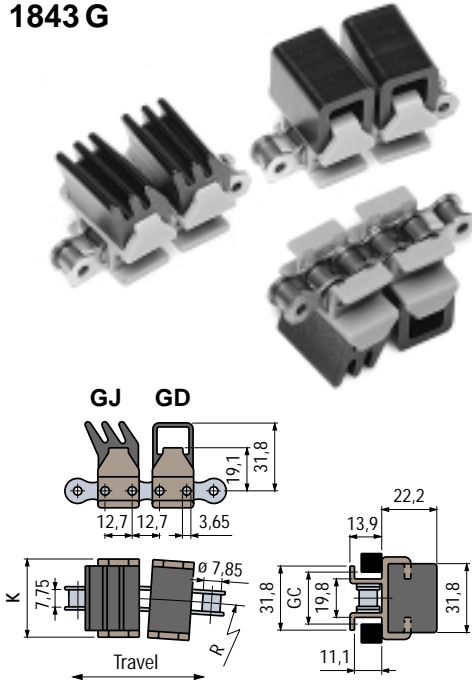

Sideflexing: Thermoplastic Top Plates, 12,7 mm \triangleq 1/2" Pitch

Rexnord Chain No.	Material		Width K mm	Radius min. R mm	GC		Weight kg/m
	Base Chain	Top Plate			Straight	Curve	
LF1843-K150GD* LF1843-K150GJ*	Steel	Rex-LF® (Brown)	38,1	254	21,4	22,2	1,2
LF1843SS-K150GD* LF1843SS-K150GJ*	Stainless Steel		38,1	254	21,4	22,2	1,2

* = Available upon request and minimum order quantity.
EPDM rubber gripper elements (black).
50 shore A hardness.
White grippers available upon request.
Standard length: 240 pitches 10 ft (3.048 m)

Standard ANSI 40 

1873 GSD

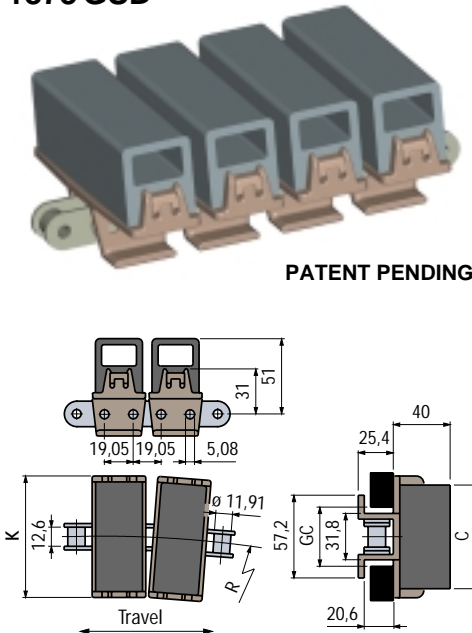

PATENT PENDING

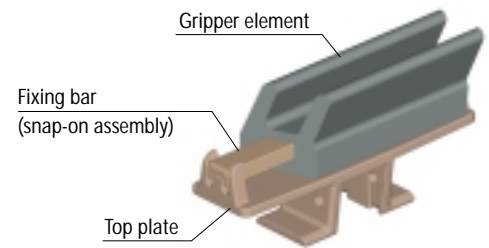

Sideflexing: Thermoplastic Top Plates, 19,05 mm \triangleq 3/4" Pitch

Rexnord Chain No.	Material		Width K mm	C mm	R min. mm	GC		Weight kg/m
	Base Chain	Top Plate Fixing bar				Straight	Curve	
HP1873-K375GSD HP1873-K473GSD	Steel	Rex-HP™ (Dark grey)	95,3 120	82 107	381	34,1	34,9	2,9 3,0
HP1873SS-K375GSD HP1873SS-K473GSD	Stainless Steel	Rex-HP™ (Dark grey)	95,3 120	82 107	381	34,1	34,9	2,9 3,0

EPDM rubber gripper elements (grey).
55 shore A nominal hardness.
White grippers available upon request.
Standard length: 160 pitches 10 ft (3.048 m)

See page 93 

Standard ANSI 60 

Gripper Chains

New version available in 95,3 and 120 mm widths.
 New rubber gripper assembly system resistant to bending.
 High quality EPDM vulanized gripper elements.
 Gripper available in different shapes and hights.
 HP™ material gives minimum friction. Bidirectional.
 Same accessories as chain 1873 Series.

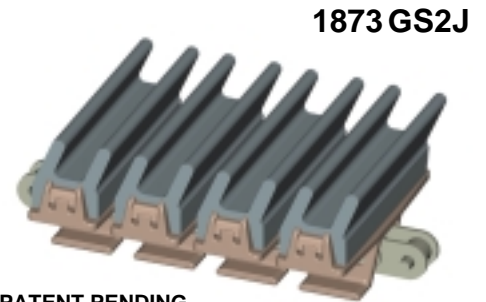
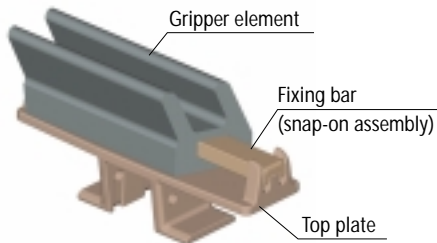

Sideflexing: Thermoplastic Top Plates, 19.05 mm \triangleq 3/4" Pitch

Rexnord Chain No.	Material		Width K mm	C mm	R min. mm	GC		Weight kg/m
	Base Chain	Top Plate Fixing bar				Straight mm	Curve mm	
HP 1873-K375GS2J HP 1873-K473GS2J	Steel	Rex - HP™ (Dark grey)	95,3 120	88 113	381	34,1	34,9	2,9 3,0
HP 1873SS-K375GS2J HP 1873SS-K473GS2J	Stainless Steel	Rex - HP™ (Dark grey)	95,3 120	88 113	381	34,1	34,9	2,9 3,0

EPDM rubber gripper elements (black).
 45 shore A nominal hardness.
White grippers available upon request.
Standard length: 160 pitches 10 ft (3.048 m)

See page 93



Standard ANSI 60



PATENT PENDING

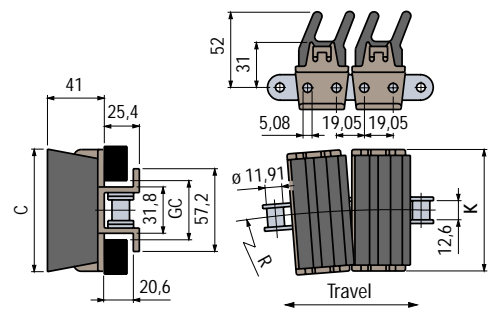

1873 GS3J

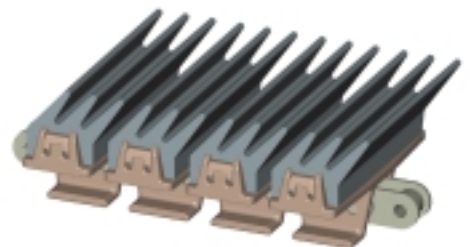

Sideflexing: Thermoplastic Top Plates, 19.05 mm \triangleq 3/4" Pitch

Rexnord Chain No.	Material		K mm	A mm	B mm	C mm	R min. mm	GC		Peso kg/m
	Base Chain	Top Plate Fixing bar						Straight mm	Curve mm	
HP 1873-K375GS3J HP 1873-K375GS3JA HP 1873-K473GS3J HP 1873-K473GS3JA	Steel	Rex - HP™ (Dark grey)	95,3 120	45 57	34 46	87 90	381	34,1	34,9	2,9 2,9 3,0 3,0
HP 1873SS-K375GS3J HP 1873SS-K375GS3JA HP 1873SS-K473GS3J HP 1873SS-K473GS3JA	Stainless Steel	Rex - HP™ (Dark grey)	95,3 120	45 57	34 46	87 90	381	34,1	34,9	2,9 2,9 3,0 3,0

Serie GS3J: EPDM rubber gripper elements (grey).
 55 shore A nominal hardness.
Serie GS3JA: EPDM rubber gripper elements (black).
 45 shore A nominal hardness.
White grippers available upon request.
Standard length: 160 pitches 10 ft (3.048 m)

See page 93



Standard ANSI 60



PATENT PENDING

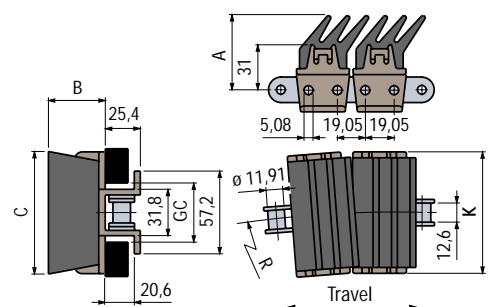

Gripper Chains

Series 1873 G. The thermoplastic top plates other than providing a quieter and smoother operation, make it possible to reduce the plant weight, increase conveying speed and permit dry service. The gripper elements are available in the "GD" type (Smooth pad) and "GJ" type (Grooved pad). They are clipped on and easily replaceable.

The base is a standard roller chain Side Bow ANSI 63 SB (pitch 19,05 mm).

Series 1873 GJM. The base chain is a standard roller chain Side Bow ANSI 63 SB (pitch 19,5 mm). The top plates are clipped on the protruding pins of the chains and are replaceable.

The gripper elements are moulded from thermoplastic rubber. Recommended for the packaging industries.

1873 G

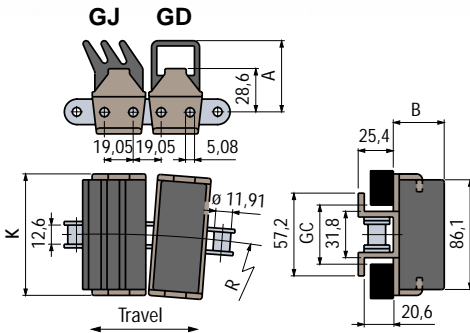

Sideflexing: Thermoplastic Top Plates, 19.05 mm \triangleq 3/4" Pitch

Rexnord Chain No.	Material		Width K mm	A mm	B mm	R min. mm	GC		Weight kg/m
	Base Chain	Top Plate					Straight mm	Curve mm	
LF1873-K375GD*	Steel	Rex-LF® (Brown)	95,3	44,4	33,3	381	34,1	34,9	2,8
LF1873-K375GJ*				44,4	33,3				
LF1873-K375GJ-A*				49,4	38,3				
LF1873SS-K375GD*	Stainless Steel		95,3	44,4	33,3	381	34,1	34,9	2,8
LF1873SS-K375GJ*									

* = Available upon request and minimum order quantity.
EPDM rubber gripper elements (black).
50 shore A hardness.
White grippers available upon request.
Standard length: 160 pitches 10 ft (3.048 m)

See page 93



Standard ANSI 60



1873 GJM

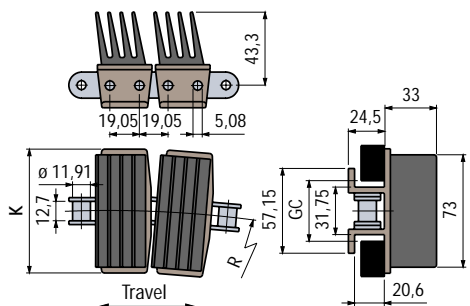

Sideflexing: Thermoplastic Top Plates, 19.05 mm \triangleq 3/4" Pitch

Rexnord Chain No.	Material		Width K mm	Radius min. R mm	GC		Weight kg/m
	Base Chain	Top Plate			Straight mm	Curve mm	
LF1873-K325GJM*	Steel	Rex-LF® (Brown)	82,5	356	33,3	34,6	3,0

* = Available upon request and minimum order quantity.
Gripper elements in thermoplastic rubber (grey).
75 shore A hardness.
Standard length: 160 pitches 10 ft (3.048 m)

See page 93



Standard ANSI 60



Gripper Chains

The thermoplastic Gripper chains, serie 880 are suitable for elevators light/medium weight products.

880 GB



Sideflexing: Single Hinge, 38.1mm \triangleq 1 1/2" Pitch

Rexnord Chain No.	Plate Material	Width K mm	Radius min. R mm	GC		Weight kg/m
				Straight mm	Curve mm	
LF880TAB-K325GB*	Rex-LF® (Brown)	82,5	457	46	44,2	0,96

* = Available upon request and minimum order quantity.
 Pin material: stainless steel.
 Gripper elements in **PUR** rubber (dark grey).
 90 shore A hardness. On request **SEBS** rubber (light grey).
 60 shore A hardness.
Standard length: 80 pitches 10 ft (3.048 m)

See page 89



See page 74/75

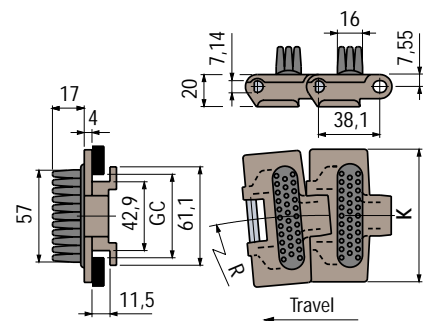

880 BO GB



Radius min. = 190

Sideflexing: Single Hinge, 38.1mm \triangleq 1 1/2" Pitch

Rexnord Chain No.	Plate Material	Width K mm	Radius min. R mm	GC		Weight kg/m
				Straight mm	Curve mm	
LF880BO-K325GB*	Rex-LF® (Brown)	82,5	190	46	44,2	0,83

* = Available upon request and minimum order quantity.
 Pin material: stainless steel.
 Gripper elements in **SEBS** rubber (light grey).
 60 shore A hardness. On request **PUR** rubber (dark grey).
 90 shore A hardness.
Standard length: 80 pitches 10 ft (3.048 m)

See page 83



See page 74/75

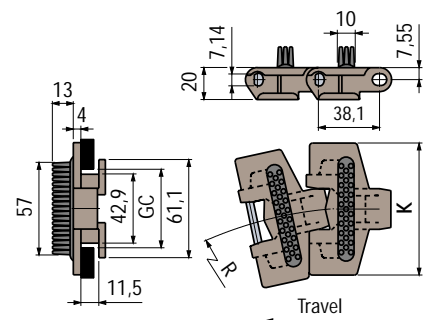

Low Backline Pressure Chains

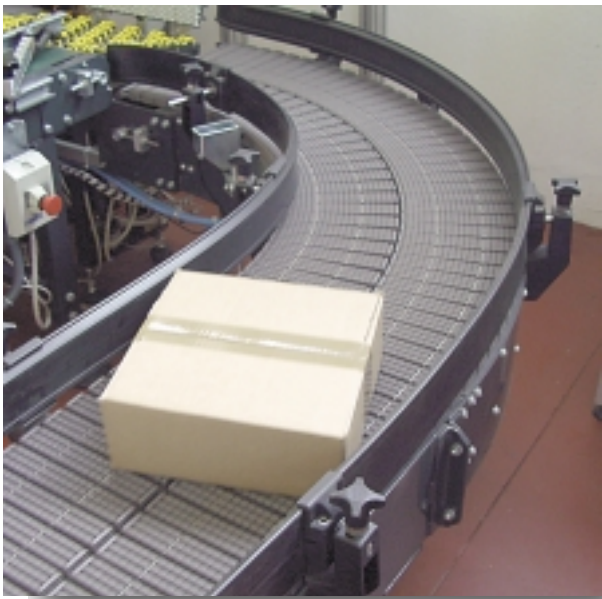

- for systems where products accumulate
- low friction coefficient between chain surface and product (0,07)
- new SLPB series in **Rex-HP™** (High Performance) for superior service
- silent operation
- high stability of product

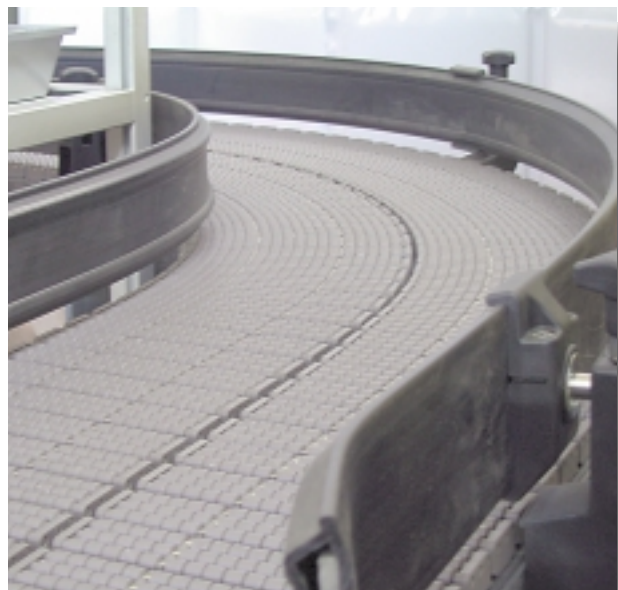
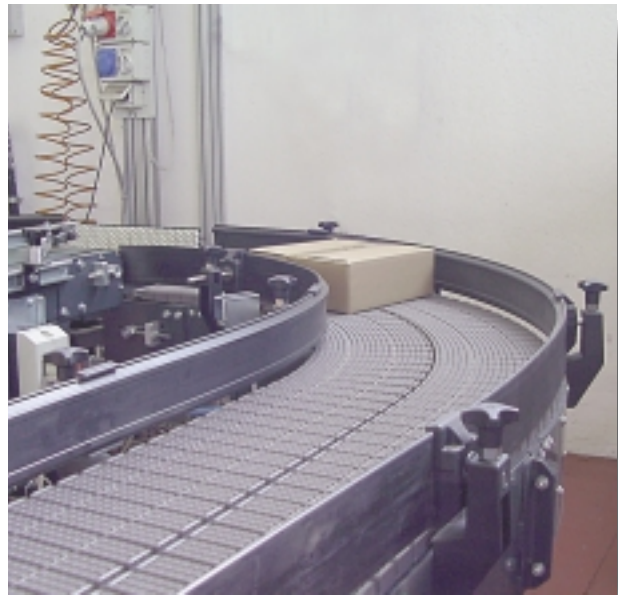

Low Backline Pressure Chains

Thermoplastic

Rex-HP™ (High Performance) material guarantees superior service and reduced noise. Product friction and accumulation pressures are reduced by 20 % with single power traction unit. Chain wear as well as chain sagging are also lower. The roller pins have inner supports for an improved stability and better product flow.

Serie SLBP 821. The base chain is the same as the 821 series. The safety hold system used for the roller pins is guaranteed by positive double retention (one end has conical coupling and the other is knurled).

Rex - HP™ = High Performance

Straight Running: Single Hinge, 38.1mm \triangleq 1 1/2" Pitch

Rexnord Chain No.	Material	Width K mm	Weight kg/m
XLBP831-K325	Rex - HP™ (Dark grey)	82,5	2,2

Pin material: stainless steel.
Standard length: 40 pitches 5 ft (1.524 m)

See page 70/71 

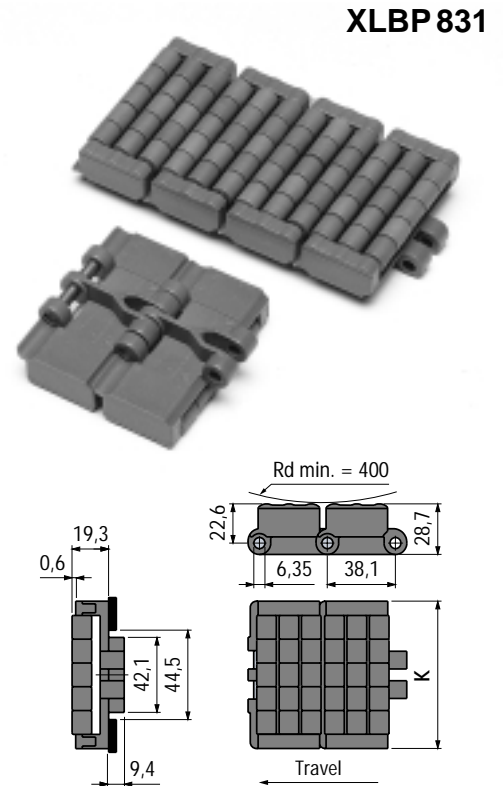

Rex - HP™ = High Performance

Straight Running: Double Hinge, 38.1 mm \triangleq 1 1/2" Pitch

Rexnord Chain No.	Material	Width K mm	Weight kg/m
SLBP821-K 750	Rex - HP™ (Dark grey)	190,5	6,1
SLBP821-K1000		254	7,6
SLBP821-K1200		304,8	9,1

Pin material: stainless steel.
Standard length: 80 pitches 10 ft (3.048 m)

See page 72/73 

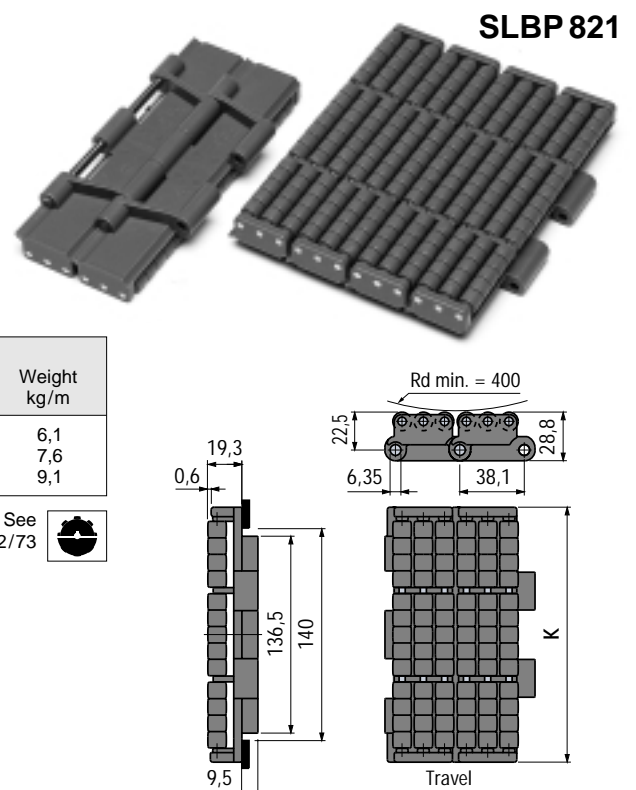

Series SLBP882 TAB. The base chain is the same as the 882 TAB series. *Rex-HP™* (High Performance) material guarantees superior service and reduced noise. Product friction as well as accumulation pressures are reduced by 20% (with single power traction unit). Reduced wear and chain sagging. Roller pin holding is guaranteed by a double retention system (one end has conical fitting and the other is knurled). The roller pins have inner supports for an improved stability and better product flow.

Low Backline Pressure Chains

Thermoplastic

SLBP 882 TAB

Rex-HP™ = High Performance

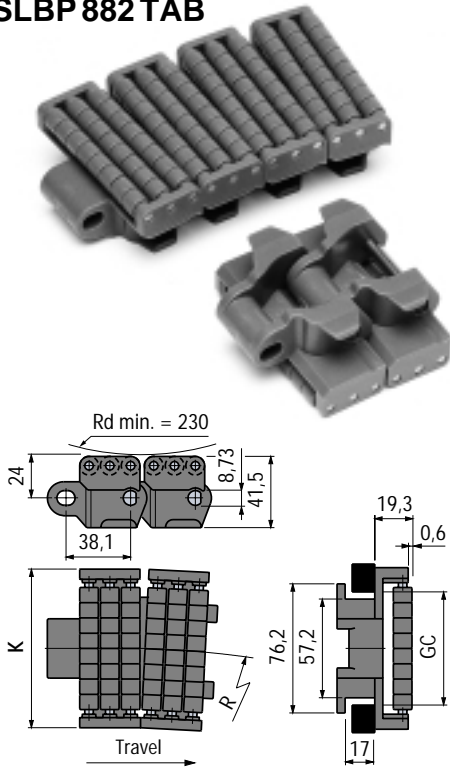

Sideflexing: Single Hinge, 38.1mm \triangleq 1 1/2" Pitch

Rexnord Chain No.	Material	Width K mm	Radius min. R mm	GC		Weight kg/m
				Straight mm	Curve mm	
SLBP882TAB-K375	Rex-HP™ (Dark grey)	95,2	667	60	58	3,9

Pin material: stainless steel.
Standard length: 80 pitches 10 ft (3.048 m)

See page 94  See page 76/77 

SLBP 882 TAB

Rex-HP™ = High Performance

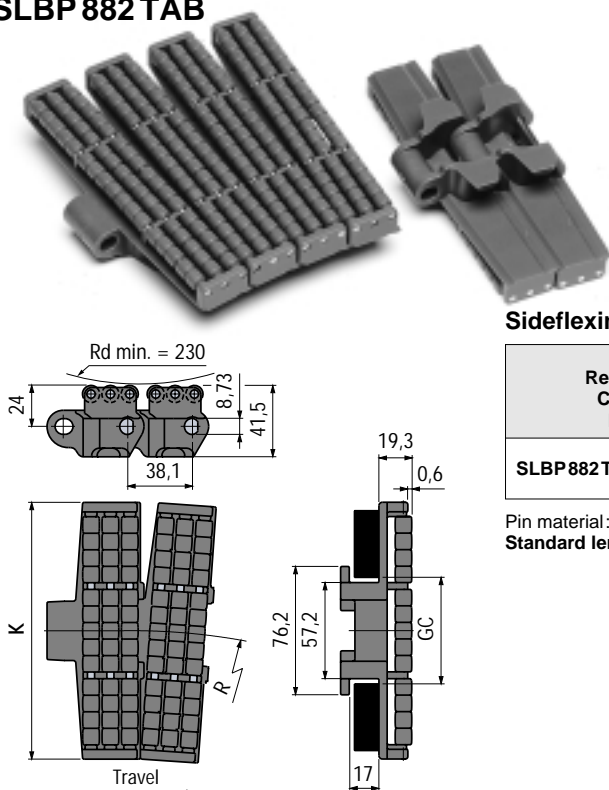

Sideflexing: Single Hinge, 38.1mm \triangleq 1 1/2" Pitch

Rexnord Chain No.	Material	Width K mm	Radius min. R mm	GC		Weight kg/m
				Straight mm	Curve mm	
SLBP882TAB-K750	Rex-HP™ (Dark grey)	190,5	610	60	58	6,12

Pin material: stainless steel.
Standard length: 80 pitches 10 ft (3.048 m)

See page 94  See page 76/77 

Low Backline Pressure Chains

Thermoplastic

Series LBP 883. These low backline pressure chains have been designed for conveying large or packaged products. The LBP 883 can be used on straight running and sideflexing conveyors. Due to the favorable backline pressure conditions, a maximum protection of the goods being conveyed is obtained. These chains operate on standard 882 style sprockets.

Series LBP 879 BO. Ideal to convey boxes, cluster-pack and delicate products. Small sideflexing radius (R min = 190 mm). Tangential sprocket, bidirectional.

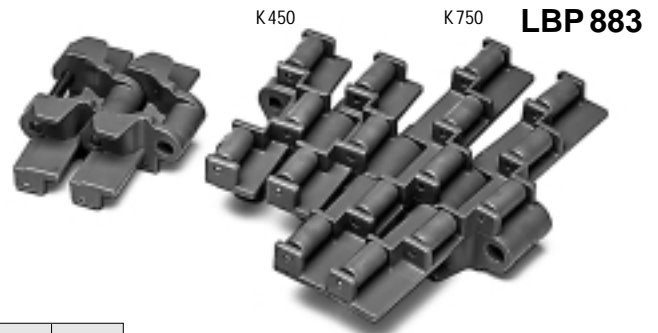

Sideflexing: Single Hinge, 38.1mm \triangle 1 1/2" Pitch

Rexnord Chain No.	Material	Width K mm	Radius min. R mm	GC		Weight kg/m
				Straight mm	Curve mm	
LBP883TAB-K450*	Rex-LF[®] (Brown)	114,3	610	60	58	2,5
LBP883TAB-K750*		190,5				3,4

* = Available upon request and minimum order quantity.
Pin material: stainless steel.
Standard length: 80 pitches 10 ft (3.048 m)

See page 94



See page 76/77

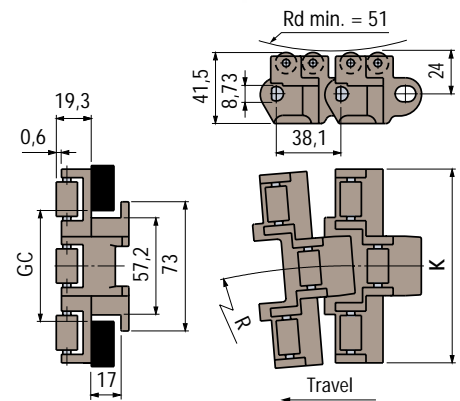

Sideflexing: Single Hinge, 38.1mm \triangle 1 1/2" Pitch

Rexnord Chain No.	Material	Width K mm	Radius min. R mm	GC		Weight kg/m
				Straight mm	Curve mm	
LBP879BO-K325*	Rex-LF[®] (Brown)	82,5	190	46	44,2	1,08

* = Available upon request and minimum order quantity.
Pin material: stainless steel.
Standard length: 80 pitches 10 ft (3.048 m)

See page 83



See page 74/75

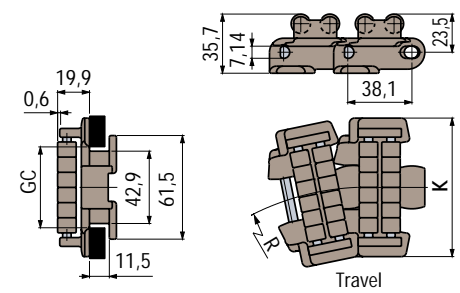

Multiflex Chains



- *the unique solution to special problems!*
- *virtually nothing is impossible with the Rexnord Multiflex chain*
- *for corner turns in the most confined spaces*

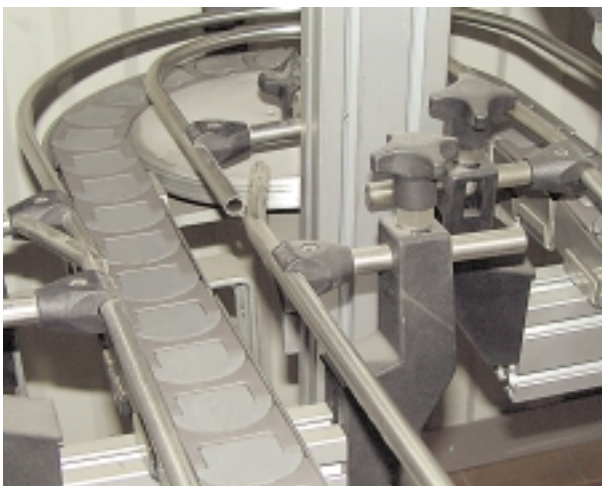
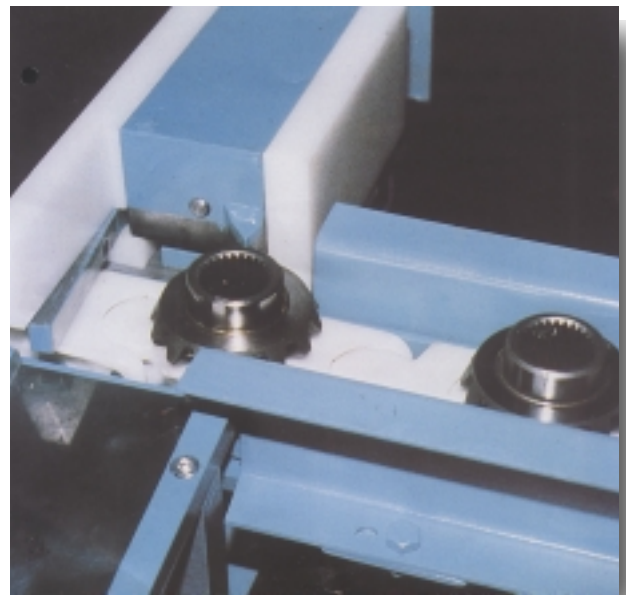

Multiflex Chains

Thermoplastic

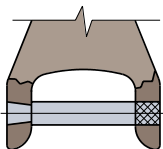

Chains of the series ...K have pins with one end conical and the other knurled for better pin retention.

Series 1765 ZeroGap™. No opening and closing of gaps during sideflexing movement as well as wrapping around the sprocket. Safe operation. Optimum product handling, with no opening where small or instable products can fall. Low noise.
Serie 1720 K. Smooth edge: better product handling, especially irregular cardboard containers. Bidirectional.

Rex - HP™ = High Performance

Sideflexing: 50 mm Pitch

Rexnord Chain No.	Material			Radius min. R mm	GC		Weight kg/m
	Link	Plate	Pin		Straight mm	Curve mm	
HP1765ZeroGap™	Rex - HP™ (Dark grey)	Special acetal (grey)	Stainless steel	125	58	58	1,45
WHP1765ZeroGap™	Rex - WHP™ (White)		Stainless steel	125	58	58	1,45
WX1765ZeroGap™	Wear resistant WX (Light green)		Stainless steel	125	58	58	1,45

Accessories: pin extractor (see page 86).
 Standard length: 61 pitches 10 ft (3,05 m)

See page 84/85/86



See page 80/81

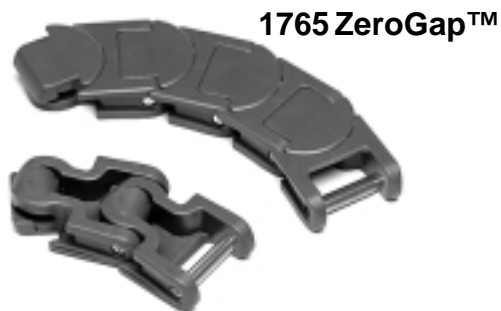

Licensed under US Patent # 6173832, European # 910540, and German # 69702857.7

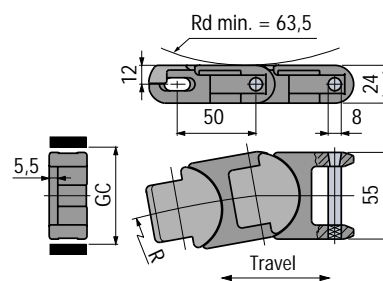

Rex - HP™ = High Performance

Sideflexing: 50 mm Pitch

Rexnord Chain No.	Material		Radius min. R mm	GC		Weight kg/m
	Link	Pin		Straight mm	Curve mm	
HP1720K	Rex - HP™ (Dark grey)	Stainless steel	140	58	58	1,26

Pivot material: polyamide.
 Accessories: pin extractor (see page 86).
 Standard length: 200 pitches 32.8 ft (10 m)

See page 84/85/86



See page 80/81

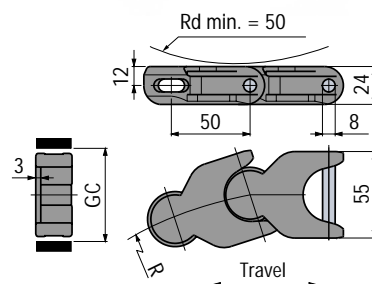

Multiflex Chains

Thermoplastic

Series 1700 K. The use of lateral corner disks guarantees the design of compact systems of different configurations and with increased number of curves. In the accumulation area it is possible to realise 60-70 mt. runs with a single power traction unit. It is recommended for the food and packaging industries (transfer of beverage containers "Brick" / "Pack" types or similar, cans, boxes). Suitable also for conveying of free pallets for the mechanical and automotive industries.

Series 1700 TAB K. The base chain is similar to the 1700 K. The TAB guides consent transfers from flat to inclined runs and viceversa. Can be used in curves either with or without corner disks.

Chains of the series ...K have pins with one end conical and the other knurled for better pin retention.

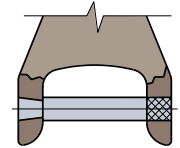

1700 K



Rex - HP™ = High Performance

Sideflexing: 50 mm Pitch

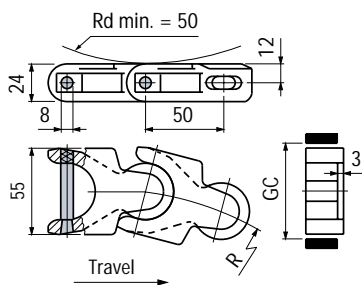

Rexnord Chain No.	Material		Radius min. R mm	GC		Weight kg/m
	Link	Pin		Straight	Curve	
C 1700K	Acetal D (White)	Stainless Steel	140	58	-	1,26
B 1700K WLF 1700K	Rex - LF® (White)	Zinc Plated Stainless Steel				
LF 1700K A 1700K	Rex - LF® (Brown)	Zinc Plated Stainless Steel				
HP 1700K	Rex - HP™ (Dark grey)	Stainless Steel				

Pivot material: polyamide.
Accessories: pin extractor (see page 86).
Standard length: 200 pitches 32.8 ft (10 m)

See page 84/85/86



See page 80/81



1700 TAB K



Sideflexing: 50 mm Pitch

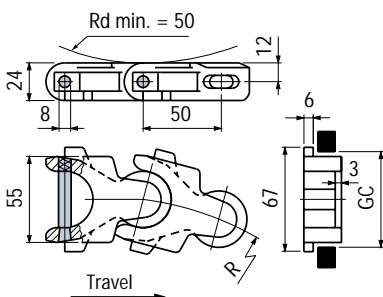

Rexnord Chain No.	Material		Radius min. R mm	GC		Weight kg/m
	Link	Pin		Straight	Curve	
WLF 1700TABK	Rex - LF® (White)	Stainless Steel	140	58	58	1,30

Pivot material: polyamide.
Accessories: pin extractor (see page 86).
Standard length: 200 pitches 32.8 ft (10 m)

See page 84/85



See page 80/81



See page 95



Multiflex Chains

Thermoplastic

Series AC 1700 C. The base chain is the same as the 1700 K series. The top surface is made of hardened steel therefore highly resistant to wear.

It is highly recommended for the mechanical and automotive industries (transport and accumulation of metallic products with sharp edges, rough casting surfaces etc.).

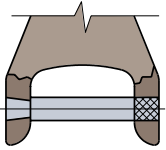

Chains of the series ...K have pins with one end conical and the other knurled for better pin retention.



Sideflexing: 50 mm Pitch, Hardened Steel Top Plates

Rexnord Chain No.	Material		Radius min. R mm	GC		Weight kg/m
	Link	Pin		Straight mm	Curve mm	
AC1700K	Acetal D (Grey)	Zinc Plated	140	58	-	1,90

Pivot material: polyamide.

Top plate characteristics:

material: zinc plated steel (yellow).

surface hardness: 50÷55 HRC.

hardened depth: 0,1 mm.

Accessories: pin extractor (see page 86).

Standard length: 200 pitches 32.8 ft (10 m)

See page 84/85



See page 80/81

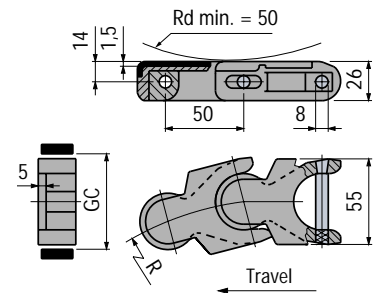

Multiflex Chains

Thermoplastic

Series 1790K. The base chain is the same as the 1700 K series. The configuration of the top surface presents a lower supporting area with consequent reduced product stability. Sliding type turning system. (Does not permit the use of corner discs).

Series 1790 TAB K. The base chain is the same as the 1790 K series. The TAB guides consent transfers from flat to inclined runs and viceversa.

Chains of the series ...K have pins with one end conical and the other knurled for better pin retention.

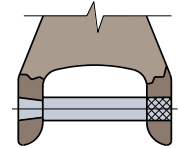

1790 K

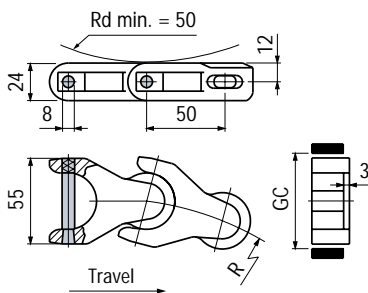

Sideflexing: 50 mm Pitch

Rexnord Chain No.	Material		Radius min. R mm	GC		Weight kg/m
	Link	Pin		Straight mm	Curve mm	
WLF1790K	Rex-LF ® (White)	Stainless Steel	140	58	58	1,26

Pivot material: polyamide.
Accessories: pin extractor (see page 86).
Standard length: 200 pitches 32.8 ft (10 m)

See page 80/81



1790 TAB K (ex 1701 TABK)

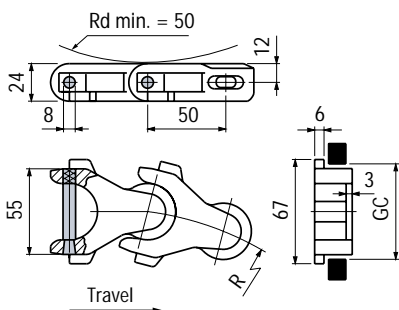
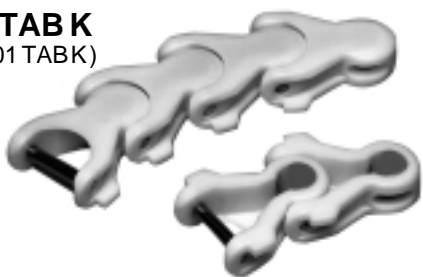

Sideflexing: 50 mm Pitch

Rexnord Chain No.	Material		Radius min. R mm	GC		Weight kg/m
	Link	Pin		Straight mm	Curve mm	
WLF1790TABK	Rex-LF ® (White)	Stainless Steel	140	58	58	1,30

Pivot material: polyamide.
Accessories: pin extractor (see page 86).
Standard length: 200 pitches 32.8 ft (10 m)

See page 95



See page 80/81



Multiflex Chains

Thermoplastic

These chains feature flush guide sides to guarantee a more efficient sanitation. Sliding type turning system. Recommended for the dairy and food industries.

Series 1702. Similar to the 1716 K series except for the material (which is FDA approved for direct contact with food stuff) and for the bi-directional use.

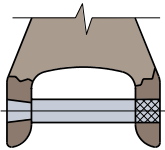

Chains of the series ...K have pins with one end conical and the other knurled for better pin retention.



Sideflexing: 50 mm Pitch

Rexnord Chain No.	Material		Radius min. R mm	GC		Weight kg/m
	Link	Pin		Straight mm	Curve mm	
W1716K	Acetal D (White)	Stainless Steel	170	59,5	56,8	1,77

Pivot material: polyamide.
Accessories: pin extractor (see page 86).
Standard length: 200 pitches 32.8 ft (10 m)

See page 80/81

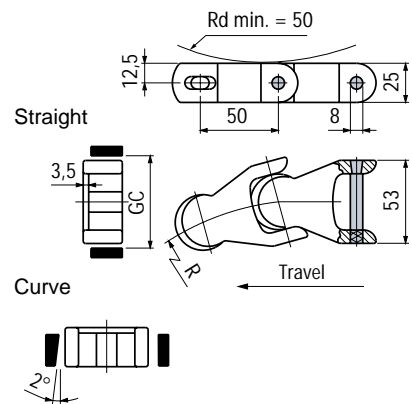

Sideflexing: 50 mm Pitch

Rexnord Chain No.	Material		Radius min. R mm	GC		Weight kg/m
	Link	Pin		Straight mm	Curve mm	
WLF1702	Rex-LF® (White)	Stainless Steel	140	59,5	56,8	1,43

Pivot material: polyamide.
Accessories: pin extractor (see page 86).
Standard length: 61 pitches 10 ft (3.05 m)

See page 80/81

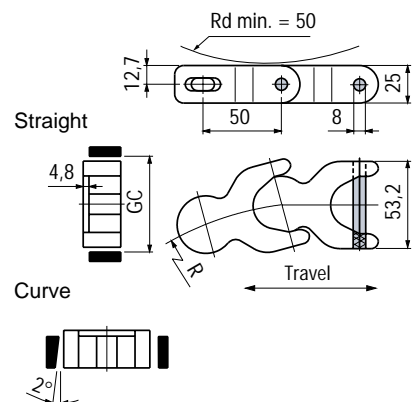

Series 1755. Reduced pitch (40 mm) Can be used with corner discs. Recommended for light duty (empty cans).

Multiflex Chains

Thermoplastic

1755

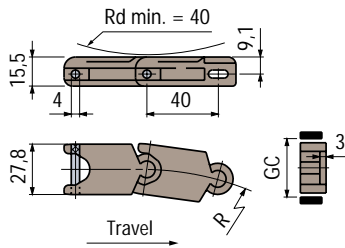

Sideflexing: 40 mm Pitch

Rexnord Chain No.	Material		Radius min. R mm	GC		Weight kg/m
	Link	Pin		Straight mm	Curve mm	
1755	Rex-LF [®] (Brown)	Stainless Steel	136,5	30,5	-	0,37

Pivot material: polyamide.

Standard length: 152 pitches 20 ft (6.080 m)

See page 86



See page 81



Multiflex Chains

Thermoplastic

Series 3150. High load carrying capacity (tensile stress 19600N). Sliding type turning system. Recommended for conveying crates and bottles to rinsing, filling, packing stations.



Sideflexing: 80 mm Pitch

Rexnord Chain No.	Material		Radius min. R mm	Weight kg/m
	Link	Pin		
A 3150*	Rex-LF ® (Brown)	Stainless Steel	450	3,75

* = Available upon request and minimum order quantity.
Pivot material: polyamide.
Standard length: 76 pitches 20 ft (6 m)

See page 81

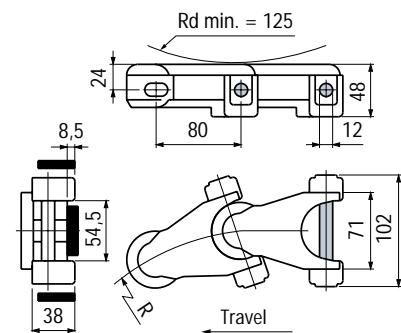

The base chain is the same as the 1700 K series. The Top plates have a large, uniform and continuous surface. Both type of chains can be used with turning wheels. They cannot be curved upwards or downwards.

Multiflex Chains

Thermoplastic

Chains of the series ...K have pins with one end conical and the other knurled for better pin retention.

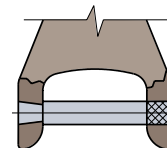

1710K



Sideflexing: 50 mm Pitch

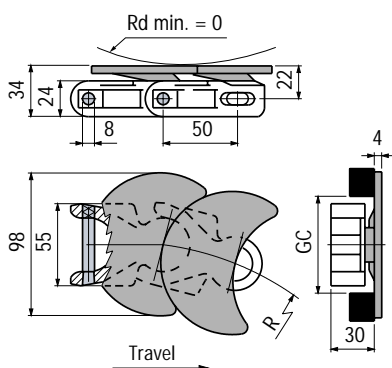

Rexnord Chain No.	Material		Radius min. R mm	GC		Weight kg/m
	Link	Top plate/Pivot		Straight	Curve	
WLF1710K	Rex-LF ® (White)	Polyamide (Grey)	140	58	-	1,88

Pin material: stainless steel
 Accessories: pin extractor (see page 86).
 Standard length: 200 pitches 32.8 ft (10 m)

See page 84/85



See page 80/81



1710TABK



Sideflexing: 50 mm Pitch

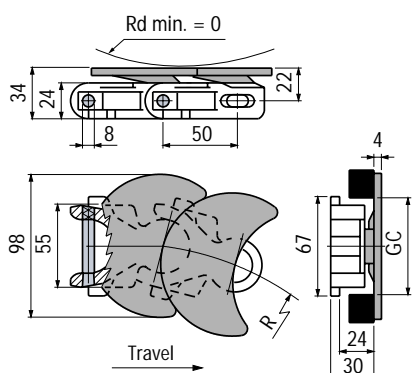

Rexnord Chain No.	Material		Radius min. R mm	GC		Weight kg/m
	Link	Top plate/Pivot		Straight	Curve	
WLF1710TABK*	Rex-LF ® (White)	Polyamide (Grey)	140	58	58	1,93

* = Available upon request and minimum order quantity.

Pin material: stainless steel
 Accessories: pin extractor (see page 86).
 Standard length: 200 pitches 32.8 ft (10 m)

See page 84/85



See page 80/81



See page 95



Multiflex Chains

Thermoplastic

The base chain is the same as the 1700 K series. The riveting of the Top plates to the links is guaranteed even in case of repeated impacts.

The chain design ensures the overlapping of the Top plates even with very tight turning radiuses.

It is recommended for use when particular safety requirements for the protection of hands and clothing have to be observed.

The materials are FDA approved. Sliding type curving system .

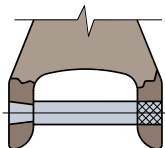

Chains of the series ...K have pins with one end conical and the other knurled for better pin retention.

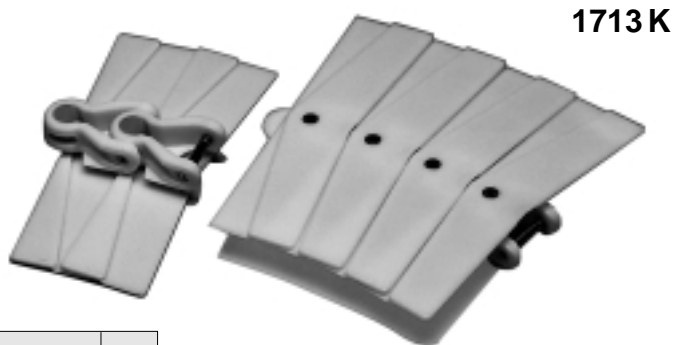

1713K

Sideflexing: 50 mm Pitch

Rexnord Chain No.	Material		Radius min. R mm	GC		Weight kg/m
	Link	Top plate		Straight	Curve	
WLF1713K*	Rex-LF ® (White)	Acetal D (White)	500	58	58	2,70

* = Available upon request and minimum order quantity.

Material:

Pin in stainless steel.

Polyamide pivot.

Inox AISI 304 rivet.

Accessories: pin extractor (see page 86).

Standard length: 200 pitches 32.8 ft (10 m)

See page 80/81

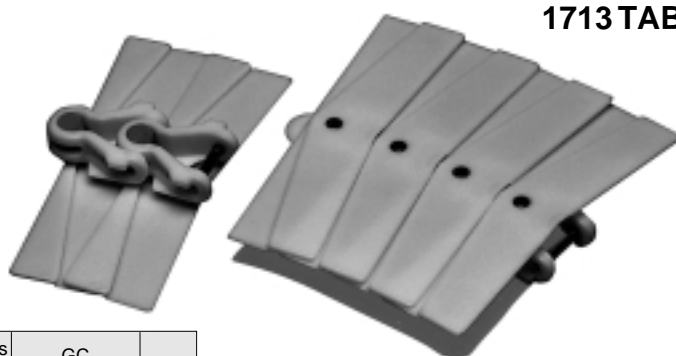
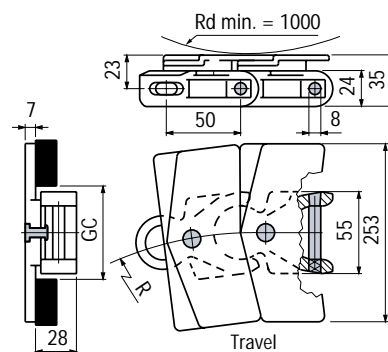

1713TABK

Sideflexing: 50 mm Pitch

Rexnord Chain No.	Material		Radius min. R mm	GC		Weight kg/m
	Link	Top plate		Straight	Curve	
WLF1713TABK*	Rex-LF ® (White)	Acetal D (White)	500	58	58	2,75

* = Available upon request and minimum order quantity.

Material:

Pin in stainless steel.

Polyamide pivot.

Inox AISI 304 rivet.

Accessories: pin extractor (see page 86).

Standard length: 200 pitches 32.8 ft (10 m)

See page 95



See page 80/81

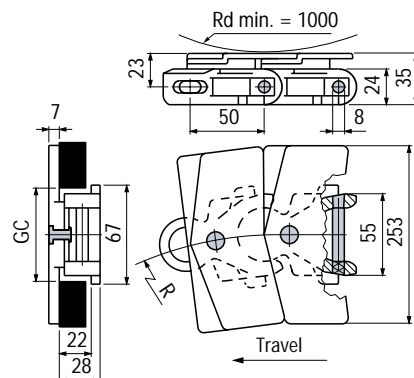

Case Conveyor Chains

- *for the toughest jobs*
- *simple design*

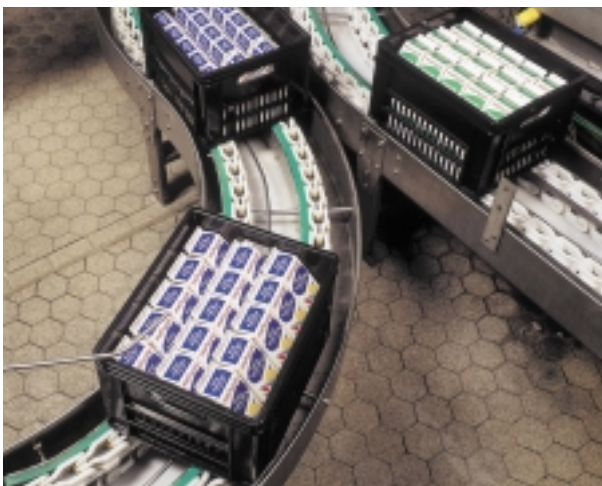

Case Conveyor Chains

from Acetal

Sideflexing

A new series of conveying chains with a simple two piece construction.

Hard wearing acetal which provides highly resistant wear surfaces and a low coefficient of friction.

Stainless steel pins provide for articulation and flexing of the chain and utilise a simple but effective method for retention in the sidebars-preventing premature wear.

The chain may be assembled or disassembled without special tools.



**A 600
A 1400**

Case conveyor Chains from Acetal

Rexnord Chain No.	Material	Pitch p mm	Width K mm	Diameter of pin E mm	Max. Sprocket Face B mm	Depth of Sidebar H mm	Weight kg/m
A 600	Acetal	63,5	43	11	14,3	29	1,44
A 1400	Acetal	82,5	50	11	15,9	38	2,08

Pin material: stainless steel

All chains will flex around a 600 mm radius.

Colour: white.

Standard length A 600: 96 pitches 20 ft (6.096 m)

Standard length A 1400: 74 pitches 20 ft (6.105 m)

See
page 79

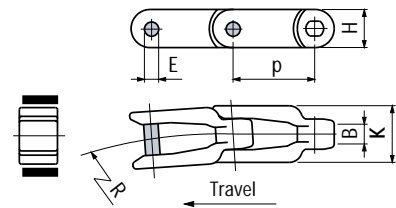

**A 600 TAB
A 1400 TAB**

Case conveyor Chains from Acetal

Rexnord Chain No.	Material	Pitch p mm	Width K mm	Diameter of pin E mm	Max. Sprocket Face B mm	Depth of Sidebar H mm	Width over Lug J mm	Height of Lug G mm	Weight kg/m
A 600 TAB*	Acetal	63,5	43	11	14,3	29	54	18	1,49
A 1400 TAB	Acetal	82,5	50	11	15,9	38	66	19	2,26

* = Available upon request and minimum order quantity.

Pin material: stainless steel

All chains will flex around a 600 mm radius.

Colour: white.

Standard length A 600 TAB: 96 pitches 20 ft (6.096 m)

Standard length A 1400 TAB: 74 pitches 20 ft (6.105 m)

See
page 79

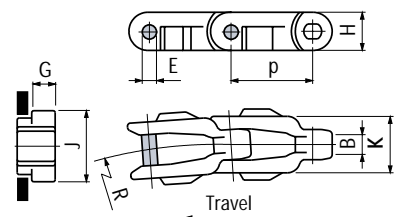

Special Chains

Special Chains

from Acetal

Series 1108. Recommended for packaging machines of the pharmaceutical, cosmetic and food industries.

When installed laterally to the base chain it eases product transport during head transfers.

Series 1080. Recommended for closed ring transport (lateral traction drive).



Straight Running: Miniature conveyor chain

Rexnord Chain No.	Material		Width K mm	Weight kg/m
	Link	Pin		
ZN1108	Acetal D (White)	Zinc plated	32	0,51
SS1108		Stainless Steel		

Standard length: 395 pitches 16.4 ft (5 m)

See page 82

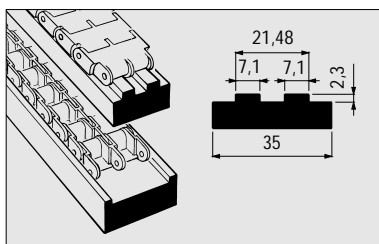

Chain guides

Transport run:

Use a T section for double roller chain "type ASA 40,2" (PE polyethylene with 1.000.000 molecular weight).

Return run:

Use a PE polyethylene section with 1.000.000 molecular weight or a stainless steel U section.

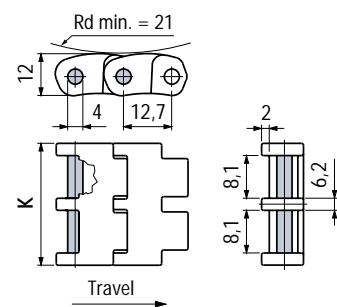

Sideflexing: Articulated chain with top plates

Rexnord Chain No.	Material link/top plate	Width K mm	Radius min. R mm	Weight kg/m
W1080SS	Acetal D (White)	85	83	1,76

Pin material: stainless steel.

Standard length: 128 pitches 26.2 ft (8 m)

See page 82

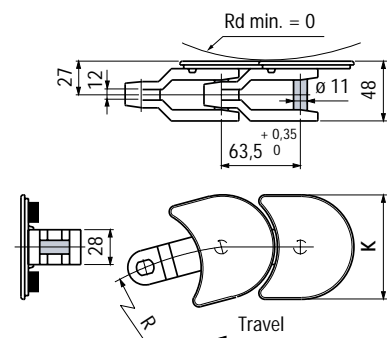

As base chain is the same as the 880 BO series.
 The moulded pushing fin permits to transport round products
 (gears, bearings etc.)
 Reduced turning circle (R min = 200 mm), possibility of lateral
 traction.

Thermo- plastic TableTop[®] Chains

With Pushers

880 BO F

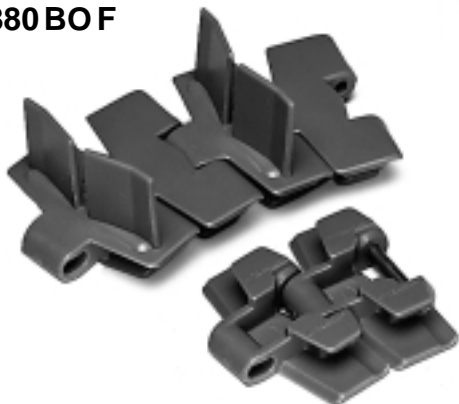

Radius min. = 190

Sidexflexing: Single Hinge, 38.1mm \triangle 1 1/2" Pitch

Rexnord Chain No.	Material	Width K mm	H mm	Radius min. R mm	GC		Weight kg/m
					Straight mm	Curve mm	
LF880BO-K325F25*	Rex-LF[®] (Brown)	82,5	25	190	46	44,2	0,96
LF880BO-K325F39*			39				

* = Available upon request and minimum order quantity.
 Pin material: stainless steel
Standard length: 80 pitches 10 ft (3.048 m)

See
 page 83



See
 page 74/75

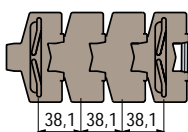
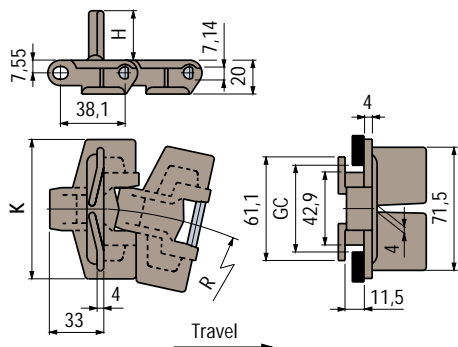

Special configurations
 on request. Indicate the
 distance between pushers
 at the time of ordering.

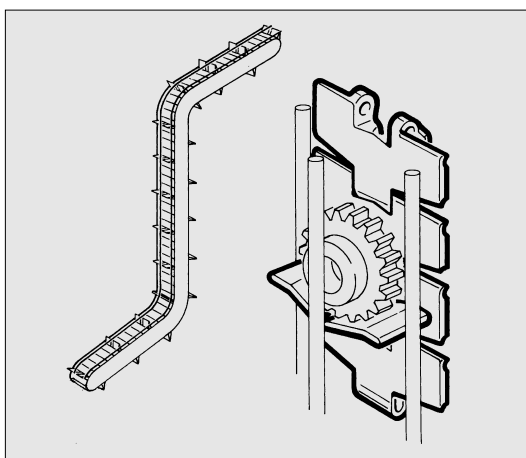

Vacuum Chains

Thermoplastic

Recommended for single strand vacuum systems (empty aluminium cans). Substitutes the magnetic system.

Series 820 vacuum. The base chain is the same as the 820 series. Available with 2 or 3 perforation per link (V2) or (V3).

Series 880 TAB vacuum. The base chain is the same as the 880 TAB series. Available with 1 or 2 perforation per link (V1) or (V2).

Straight Running: Single Hinge, 38.1mm \triangleq 1 1/2" Pitch

Rexnord Chain No.	Material	Width K mm	Hole dia.		l mm	Weight kg/m
			d1 mm	d2 mm		

V2 - Two holes

LF820-K325V2*	Rex-LF® (Brown)	82,5	6,5	-	19	0,83
LF820-K350V2*		88,9	4	-	45	0,87
LF820-K450V2130*		114,3	8	-	30	1,03
LF820-K450V2150*		114,3	8	-	50	1,03

V3 - Three holes

LF820-K325V3*	Rex-LF® (Brown)	82,5	7,9	4,4	20	0,83
---------------	---------------------------	------	-----	-----	----	------

* = Available upon request and minimum order quantity.
Pin material: stainless steel.

Standard length: 80 pitches 10 ft (3.048 m)

See page 70/71

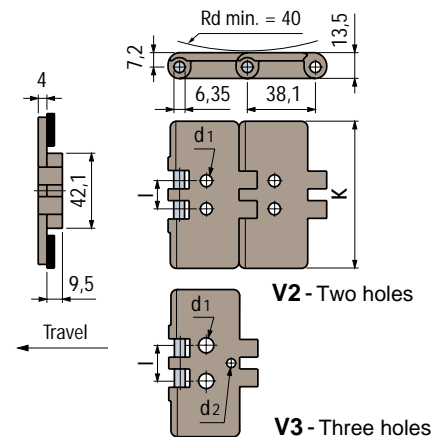
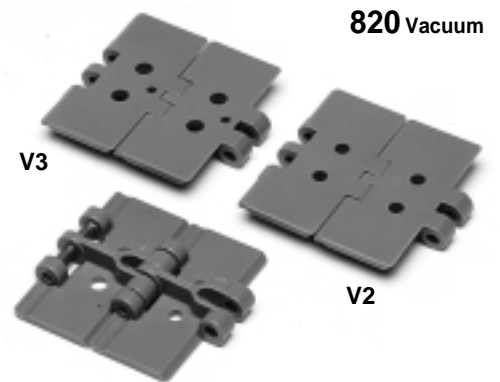

880 TAB Vacuum



Sideflexing: Single Hinge, 38.1mm \triangleq 1 1/2" Pitch

Rexnord Chain No.	Material	Width K mm	Hole dia. d1 mm	l mm	Radius min. R mm	GC		Weight kg/m
						Straight	Curve	

V1 - One hole

LF880TAB-K325V1..*	Rex-LF® (Brown)	82,5	5 - 6 - 6,5 8 - 10	-	457	46	44,2	0,94
--------------------	---------------------------	------	-----------------------	---	-----	----	------	------

V2 - Two holes

LF880TAB-K325V2..*	Rex-LF® (Brown)	82,5	6	24	457	46	44,2	0,94
LF880TAB-K450V2..**			8	20				
LF880TAB-K450V2..**		114,3	6	24	500	46	44,2	1,08

* = Available upon request and minimum order quantity.

On order indicate the hole dia. d1.

** = Available upon request and minimum order quantity.

Pin material: stainless steel.

Standard length: 80 pitches 10 ft (3.048 m)

See page 89



See page 74/75

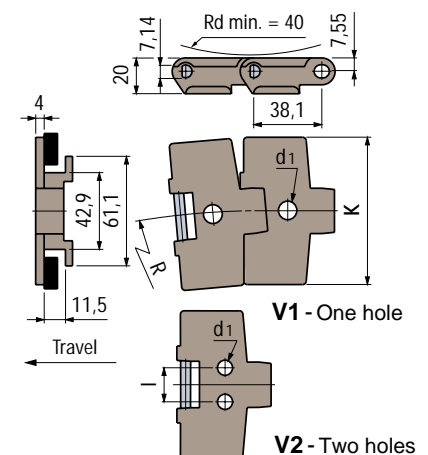

*Sprockets
and Idler
Wheels
Corner
Tracks and
Straight
Tracks*

Sprockets

for Series 812, 815, 881 M, SSR 812 Rubber Top

Split Thermoplastic (NS) Sprockets

Rexnord Order No.	No of Teeth		Pitch Dia. d mm	Outside Dia. da mm	Finished Bore with Keyway d1 mm	L mm			Weight kg
	Actual	Effective				L	Ln	mm	

Bore (mm)

NS 815 T21 R...	21	10,5	129,26	129,5	25 30 35 40 45	52	51	0,47
NS 815 T23 R...*	23	11,5	141,22	142	25 30 35 40 45	52	51	0,55
NS 815 T25 R...	25	12,5	153,21	154,2	25 30 35 40 45	54	58,5	0,60

Bore (inch)

NS 815 T21 R...*	21	10,5	129,26	129,5	1" 11/4" 2"	52	51	0,47
NS 815 T23 R...*	23	11,5	141,22	142	1" 11/4" 11/2" 1 3/4" 2"	52	51	0,55
NS 815 T25 R...	25	12,5	153,21	154,2	1" 11/4" 11/2" 2"	54	58,5	0,60

* = Available upon request and minimum order quantity.

Material: sprocket in reinforced polyamide (black). Bolts in stainless steel AISI 304, nuts in nickel plated brass.

Keyway: UNI 6604-69. See page 101. Max recommended tightening torque: 1 kgm.

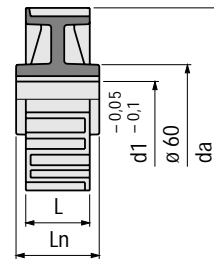

NS 815



Split Thermoplastic (NS) Sprockets

Rexnord Order No.	No of Teeth	Pitch Dia. d mm	Outside Dia. da mm	Finished Bore d1 mm	Weight kg
NS 815 T29 R...	29	14,5	177,24	75 87	0,66

Material: sprocket in reinforced polyamide (black). Bolts and nuts in stainless steel AISI 304. Keying to tubular shaft with ø12 cylindrical pin.

Max recommended tightening torque: 1 kgm. Use: tunnel washing machines, wide accumulation tables.

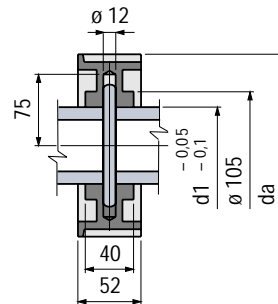

NS 815



Split Thermoplastic (KUS) Sprockets

Rexnord Order No.	No of Teeth	Pitch Dia. d mm	Outside Dia. da mm	Finished Bore with Keyway d1 mm	Weight kg
KUS 815 T19 R...*	19	9,5	117,35	20 30 35 40	0,45
KUS 815 T21 R...*	21	10,5	129,26	20 30 35 40	0,58
KUS 815 T23 R...*	23	11,5	141,22	20 30 35 40	0,65
KUS 815 T25 R...*	25	12,5	153,21	20 30 35 40 50 60	0,77
KUS 815 T27 R...*	27	13,5	165,21	20 30 35 40	0,90

* = Available upon request and minimum order quantity.

• = Plain Bore. Without keyway. Tolerance $d1 = +0,3_0$
Material: sprocket in polyamide (black). Bolts and nuts in stainless steel AISI 304.

Keyway: UNI 6604-69. See page 101. Max recommended tightening torque: 1 kgm. Half-section fixing nuts (self-locking).

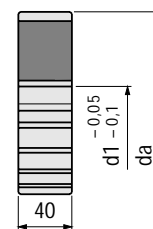

KUS 815



Thermoplastic (N) Sprockets

Rexnord Order No.	No of Teeth	Pitch Dia. d mm	Outside Dia. da mm	Finished Bore with Keyway d1 mm	dn mm	L mm	Ln mm	Weight kg
N 820 T15 R...*	15	7,5	93,67	25 30	43	50	50	0,18
N 820 T17 R...*	17	8,5	105,48	25 30	43	51	48	0,22
N 820 T19 R...*	19	9,5	117,35	20 25 30 35 40	60	50	50	0,35

* = Available upon request and minimum order quantity.

Material: sprocket in reinforced polyamide (black). Keyway: UNI 6604-69. See page 101.

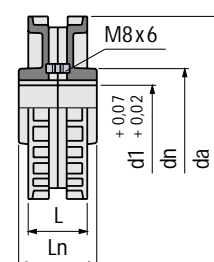

N 820



Sprockets Idler wheels

Example of codenumber : NS 815 T25 R 35 (including bore)

Sprockets

for Series 812, 815, 881 M, SSR 812 Rubber Top

KU 815

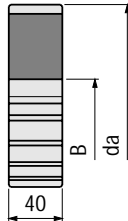

Thermoplastic (KU) Sprockets

Rexnord Order No.	No. of Teeth Actual Effective	Pitch Dia. d mm	Outside Dia. da mm	Plain Bore B mm	Max. Bore mm	Weight kg
KU 815 T19 R20*	19 9,5	117,35	117	20	60	0,40
KU 815 T21 R20	21 10,5	129,26	129	20	67	0,50
KU 815 T23 R20*	23 11,5	141,22	142	20	75	0,61
KU 815 T25 R20	25 12,5	153,21	154	20	80	0,74
KU 815 T27 R20*	27 13,5	165,21	166	20	85	0,88

* = Available upon request and minimum order quantity.

Material: polyamide (black)

GG 820

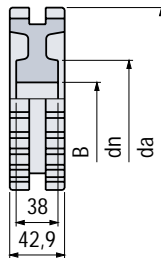

Semi-Steel (GG) Sprockets

Rexnord Order No.	No. of Teeth Actual Effective	Pitch Dia. d mm	Outside Dia. da mm	Plain Bore B mm	dn mm	Max. Bore mm	Weight kg
GG 820 T19 R19	19 9,5	117,35	117	19	52	32	1,9
GG 820 T21 R19	21 10,5	129,26	129	19	64	45	2,0
GG 820 T23 R19	23 11,5	141,22	142	19	64	45	2,5
GG 820 T25 R19	25 12,5	153,21	154	19	64	50	2,7
GG 820 T27 R19*	27 13,5	165,21	166	19	72	50	6,1
GG 820 T29 R19	29 14,5	177,24	179	19	78	50	7,1
GG 820 T31 R19*	31 15,5	189,27	191	19	78	50	3,2
GG 820 T41 R19*	41 20,5	249,59	252	19	105	50	6,7

* = Available upon request and minimum order quantity.

Accessories: guide rings.

S815-SS815

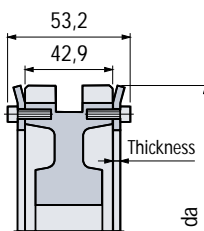

815 Guide Rings, Steel (S), Stainless Steel (SS)

Rexnord Order No.		No. of Teeth of Sprocket	Outside Dia. da mm	Thickness mm	Weight kg
Steel	Stainless steel				
S815 T19-20	SS815 T19-20	19-20	116,3	3,2	0,17
S815 T21-22	SS815 T21-22	21-22	129,3	3,2	0,20
S815 T23-24	SS815 T23-24*	23-24	141,2	3,2	0,21
S815 T25-26	SS815 T25-26	25-26	153,4	3,2	0,21
S815 T27-28*	SS815 T27-28	27-28	165,9	3,2	0,24
S815 T29*	SS815 T29	29	178,3	3,2	0,25
S815 T31	SS815 T31	31	190,5	3,2	0,30
S815 T41*	SS815 T41	41	251,2	3,2	0,42

* = Available upon request and minimum order quantity.

Supplied with fixing screws.

Example of codenumber : KU 815 T19 R20

Idler Wheels

for Series 812, 815, 881 M, SSR 812 Rubber Top

Split Thermoplastic (NSXT) Idler Wheels

Rexnord Order No.	Equivalent No. of Teeth	Outside Dia. da mm	Finished Bore d1 mm	dn (mm)		Weight kg
				d1= 25-30	d1= 35-45	
NSXT 820 T21 R...	21	130	25 30 35 40	40	50	0,26
NSXT 820 T23 R...*	23	142,5	25 30 35 40	40	50	0,29
NSXT 820 T25 R...	25	154,5	25 30 35 40 45	40	50	0,30

* = Available upon request and minimum order quantity.

Max recommended tightening torque: 0,6 kgm.

Material: polyamide (black).

Also available in Glistamide® black (special material).

Bolts and nuts in stainless steel AISI 304.

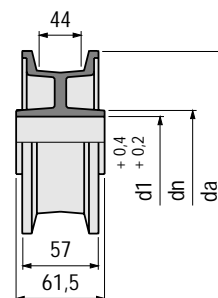

NSXT 820



Thermoplastic (NXT) Idler Wheels

Rexnord Order No.	Equivalent No. of Teeth	Outside Dia. da mm	Finished Bore d1	dn mm	L mm	Ln mm	Weight kg
-------------------	-------------------------	--------------------	------------------	-------	------	-------	-----------

Bore (mm)

NXT 820 T15 R...	15	95,5	25 30	40	55	92	0,20
NXT 820 T17 R...	17	106,5	25 30	42	53	57	0,18
NXT 820 T18 R...*	18	113	25 30	40	57	92	0,24
NXT 820 T19 R...	19	118	25 30 40	42●	57	57	0,20
NXT 820 T21 R...	21	130	25 30 35 40	d1+10	60	61,5	0,22
NXT 820 T23 R...	23	142,5	25 30 35 40 45 50	d1+10	59,5●●	61,5	0,27
NXT 820 T25 R...	25	154,5	25 30 35 40	d1+10	59	61,5	0,30

Bore (inches)

NXT 820 T19 R...*	19	118	1"	42	57	57	0,20
NXT 820 T21 R...	21	130	1 1/4" 1 1/2"	40■	60	61,5	0,22
NXT 820 T23 R...	23	142,5	1 1/4" 1 1/2"	40■	59,5	61,5	0,27
NXT 820 T25 R...	25	154,5	1 1/4" 1 1/2"	40■	59	61,5	0,30

* = Available upon request and minimum order quantity.

Material: polyamide (black).

● = 51 with d1= 40.

●● = 61,5 with d1= 45-50.

■ = 45 with d1 = 1 1/2".

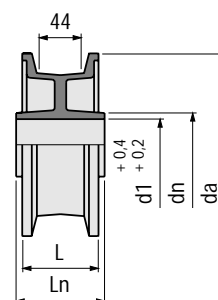

NXT 820



Example of codenumber : NSXT 820 T25 R 35 (including bore)

Sprockets

for Series 802, 805, SSC 802 Rubber Top

NS 821

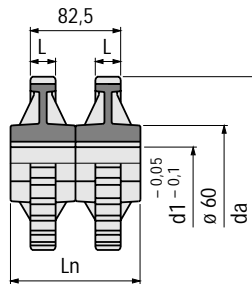

Split Thermoplastic (NS) Sprockets

Rexnord Order No.	No of Teeth		Pitch Dia. d mm	Outside Dia. da mm	Finished Bore with Keyway d1	L mm	Ln mm	Weight kg
	Actual	Effective						

Bore (mm)

NS 821 T21 R...	21	10,5	129,26	129,5	35 40 45	31	103	0,38
NS 821 T23 R...	23	11,5	141,22	142	35 40 45	31	103	0,38
NS 821 T25 R...	25	12,5	153,21	154,2	35 40 45	33	117	0,52

Bore (inch)

NS 821 T21 R...	21	10,5	129,26	129,5	1" 11/4"	31	103	0,38
NS 821 T23 R...	23	11,5	141,22	142	1"	31	103	0,38
NS 821 T25 R...	25	12,5	153,21	154,2	1" 11/4"	33	117	0,52

Material: sprocket in reinforced polyamide (black). Bolts in stainless steel AISI 304, nuts in nickel plated brass.

Keyway: UNI 6604-69. See page 101.

Max recommended tightening torque: 1 kgm. The sprocket consists of four sections.



KUS 821

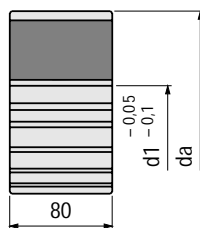

Split Thermoplastic (KUS) Sprockets

Rexnord Order No.	No of Teeth		Pitch Dia. d mm	Outside Dia. da mm	Finished Bore with Keyway d1 mm	Weight kg
	Actual	Effective				

KUS 821 T21 R...*	21	10,5	129,26	129,5	20 • 35 40 45	1,03
KUS 821 T23 R...*	23	11,5	141,22	142	20 • 35 40 45	1,23
KUS 821 T25 R...*	25	12,5	153,21	154,2	20 • 35 40 45	1,46
KUS 821 T27 R...*	27	13,5	165,21	166	20 • 35 40 45	1,67
KUS 821 T29 R...*	29	14,5	177,24	179	20 • 35 40 45	2,06

* = Available upon request and minimum order quantity.

• = Plain Bore. Without keyway. Tolerance d1 = $+0,3$
 0

Material: sprocket in polyamide (black). Bolts and nuts in stainless steel AISI 304.

Keyway: UNI 6604-69. See page 101.

Max recommended tightening torque: 1 kgm. Half-section fixing nuts (self-locking).

N 800

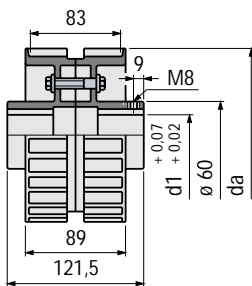

Thermoplastic (N) Sprockets

Rexnord Order No.	No of Teeth		Pitch Dia. d mm	Outside Dia. da mm	Finished Bore with Keyway d1 mm	Weight kg
	Actual	Effective				

N 800 T25 R...	25	12,5	153,21	154,2	30 35 40	1,05
----------------	----	------	--------	-------	----------	------

Material: polyamide (black).

Bolts and nuts in zinc plated steel.

Keyway: UNI 6604-69. See page 101.

KU 821

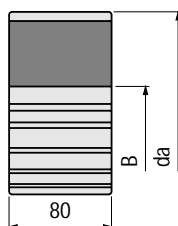

Thermoplastic (KU) Sprockets

Rexnord Order No.	No. of Teeth		Pitch Dia. d mm	Outside Dia. da mm	Plain Bore B mm	Max. Bore mm	Weight kg
	Actual	Effective					

KU 821 T21 R19	21	10,5	129,26	129	19	45	0,77
KU 821 T23 R19*	23	11,5	141,22	142	19	45	0,88
KU 821 T25 R19	25	12,5	153,21	154	19	45	1,01
KU 821 T27 R19*	27	13,5	165,21	166	19	45	1,19
KU 821 T29 R19	29	14,5	177,24	179	19	45	1,47

* = Available upon request and minimum order quantity.

Material: polyamide (black)

GG 821

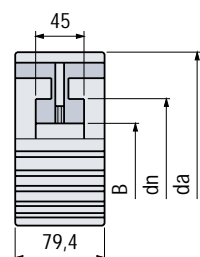

Semi-Steel (GG) Sprockets

Rexnord Order No.	No. of Teeth		Pitch Dia. d mm	Outside Dia. da mm	Plain Bore B mm	dn mm	Max. Bore mm	Weight kg
	Actual	Effective						

GG 821 T21 R19	21	10,5	129,26	129	19	64	45	3,0
GG 821 T23 R19*	23	11,5	141,22	142	19	64	45	3,2
GG 821 T25 R19*	25	12,5	153,21	154	19	74	45	3,3
GG 821 T27 R19*	27	13,5	165,21	166	19	74	45	3,4
GG 821 T29 R19*	29	14,5	177,24	179	19	64	45	3,6

* = Available upon request and minimum order quantity.

Example of codenumber : KUS 821 T25 R 35 (including bore)

Idler Wheels

for Series 802, 805, SSC 802 Rubber Top

Split Thermoplastic (NSX) Idler Wheels

Rexnord Order No.	No of Teeth		Pitch Dia. d mm	Outside Dia. da mm	Finished Bore d1 mm	L mm	Ln mm	Weight kg
	Actual	Effective						
NSX 821 T21 R...	21	10,5	129,26	129,5	30 35 40	31	103	0,38
NSX 821 T23 R...	23	11,5	141,22	142	30 35 40	31	103	0,38
NSX 821 T25 R...	25	12,5	153,21	154,2	30 35 40	33	117	0,43

Material: sprocket in polyamide (black).
Bolts in stainless steel AISI 304, nuts in nickel plated brass.
Max recommended tightening torque: 0,6 kgm.

The wheel consists of four sections.

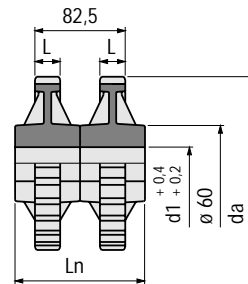
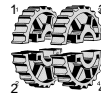

NSX 821



Thermoplastic (NX) Idler Wheels

Rexnord Order No.	No of Teeth		Pitch Dia. d mm	Outside Dia. da mm	Finished Bore d1 mm	Weight kg
	Actual	Effective				
NX 800 T25 R...*	25	12,5	153,21	154,2	30 35 40	0,96

* = Available upon request and minimum order quantity.
Bolts and nuts in zinc plated steel.

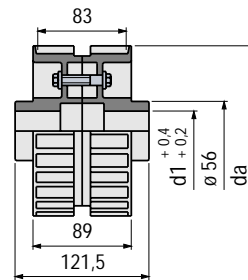

NX 800



Thermoplastic (KXT) Idler Wheels

Rexnord Order No.	Equivalent No. of Teeth	Outside Dia. da mm	Plain Bore B mm	Weight kg
KXT 800 T 21 R25	21	129,8	25	0,9
KXT 800 T 23 R25*	23	142,3	25	1,0
KXT 800 T 25 R25	25	154,7	25	1,1

* = Available upon request and minimum order quantity.
Material: polyamide (black)

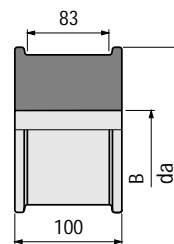

KXT 800



Sprockets

for Series 512

Steel (ST) Sprockets, 25.4 mm Pitch

Rexnord Order No.	No. of Teeth	Pitch Dia. d mm	Outside Dia. da mm	Plain Bore B mm	Max. Bore mm	Weight kg
ST 512 T13 R20*	13	106,14	108	20	48	2,5
ST 512 T15 R20*	15	122,17	124	20	56	3,4
ST 512 T17 R20*	17	138,23	141	20	63	3,9
ST 512 T19 R20*	19	154,32	157	20	70	5,0
ST 512 T21 R20*	21	170,42	173	20	80	6,5
ST 512 T23 R20*	23	186,54	190	20	85	8,3
ST 512 T25 R20*	25	202,66	206	20	90	10,0

* = Available upon request and minimum order quantity.

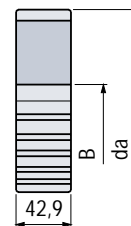

ST 512



Example of codenumber : NX 800 T25 R 40 (including bore)

Sprockets

for Series 881, 881 TAB, 8811, 8811 TAB, SSR 812-K 125/175, SSR 812 TAB Rubber Top, SSC 8811 TAB Rubber Top

NS 881

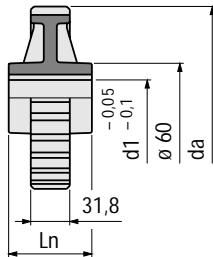

Split Thermoplastic (NS) Sprockets

Rexnord Order No.	No of Teeth	Pitch Dia. d mm	Outside Dia. da mm	Finished Bore with Keyway d1	Ln mm	Weight kg
-------------------	-------------	-----------------	--------------------	------------------------------	-------	-----------

Foro (mm)

NS 881 T21 R...	21	10,5	129,26	129,5	25 30 35 40 45	51	0,39
NS 881 T23 R...*	23	11,5	141,22	142	25 30 35 40 45	51	0,44
NS 881 T25 R...*	25	12,5	153,21	154,2	25 30 35 40 45	58,5	0,52

Foro (inch)

NS 881 T21 R...*	21	10,5	129,26	129,5	1" 1 1/4" 1 1/2"	51	0,39
NS 881 T23 R...*	23	11,5	141,22	142	1" 1 1/4"	51	0,44
NS 881 T25 R...*	25	12,5	153,21	154,2	1" 1 1/4" 1 1/2"	58,5	0,52

* = Available upon request and minimum order quantity. Keyway: UNI 6604-69. See page 101.
Material: sprocket in reinforced polyamide (black). Max recommended tightening torque: 1 kgm.
Bolts in stainless steel AISI 304, nuts in nickel plated brass.

KUS 881

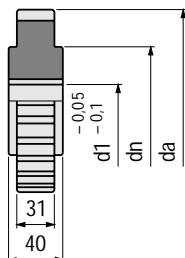

Split Thermoplastic (KUS) Sprockets

Rexnord Order No.	No of Teeth	Pitch Dia. d mm	Outside Dia. da mm	Finished Bore with Keyway d1 mm	dn mm	Weight kg
-------------------	-------------	-----------------	--------------------	---------------------------------	-------	-----------

* = Available upon request and minimum order quantity. Keyway: UNI 6604-69. See page 101.
● = Plain Bore. Without keyway. Tolerance $d1 = +0,3_0$. Max recommended tightening torque: 1 kgm.
Material: sprocket in polyamide (black). Half-section fixing nuts (self-locking).
Bolts and nuts in stainless steel AISI 304.

KU 881

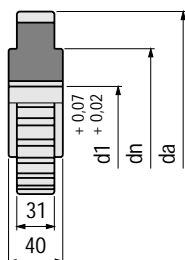

Thermoplastic (KU) Sprockets

Rexnord Order No.	No. of Teeth	Pitch Dia. d mm	Outside Dia. da mm	Finished Bore with Keyway d1 mm	dn mm	Weight kg
-------------------	--------------	-----------------	--------------------	---------------------------------	-------	-----------

* = Available upon request and minimum order quantity. Keyway: UNI 6604-69. See page 101.
● = Plain Bore. Without keyway. Tolerance $d1 = +0,3_0$.
Material: sprocket in polyamide (black).

GG 881

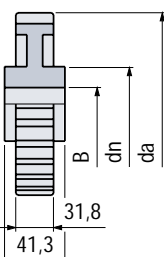

Semi-Steel (GG) Sprockets

Rexnord Order No.	No. of Teeth	Pitch Dia. d mm	Outside Dia. da mm	Plain Bore B mm	dn mm	Max. Bore mm	Weight kg
-------------------	--------------	-----------------	--------------------	-----------------	-------	--------------	-----------

Example of codenumber : NS 881 T25 R 35 (including bore)

Idler Wheels

for Series 881, 881 TAB, 8811, 8811 BO, 8811 TAB, SSR 812-K 125/175, SSR 812 TAB Rubber Top, SSC 8811 TAB Rubber Top

Split Thermoplastic (NSX) Idler Wheels

Rexnord Order No.	No of Teeth		Pitch Dia. d mm	Outside Dia. da mm	Finished Bore d1 mm	Ln mm	Weight kg
	Actual	Effective					
NSX 881 T21 R...*	21	10,5	129,26	129,5	30 35 40	51	0,39
NSX 881 T23 R...*	23	11,5	141,22	142	30 35 40	51	0,44
NSX 881 T25 R...	25	12,5	153,21	154,2	30 35 40	58,5	0,52

* = Available upon request and minimum order quantity.
Material: sprocket in polyamide (black).
Bolts in stainless steel AISI 304, nuts in nickel plated brass.

Max recommended tightening torque: 0,6 kgm.
Half-section fixing nuts (self-locking).

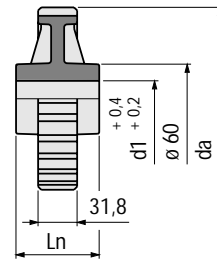

NSX 881



Thermoplastic (NX) Idler Wheels

Rexnord Order No.	No of Teeth		Pitch Dia. d mm	Outside Dia. da mm	Finished Bore d1 mm	Weight kg
	Actual	Effective				
NX 881 T25 R...	25	12,5	153,21	154,2	30 35	0,40

Material: polyamide (black).

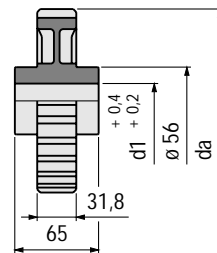

NX 881



only for Series 881 - 8811 (BEVEL)

Split Thermoplastic (NSXT) Idler Wheels

Rexnord Order No.	Equivalent No. of Teeth	Outside Dia. da mm	Finished Bore d1 mm	dn (mm)		Weight kg
				d1= 25-30	d1= 35-45	
NSXT 820 T21 R...	21	130	25 30 35 40	40	50	0,26
NSXT 820 T23 R...*	23	142,5	25 30 35 40	40	50	0,29
NSXT 820 T25 R...	25	154,5	25 30 35 40 45	40	50	0,30

* = Available upon request and minimum order quantity.

Max recommended tightening torque: 0,6 kgm.

Material: polyamide (black).
Also available in Glistamide® black (special material).
Bolts and nuts in stainless steel AISI 304.

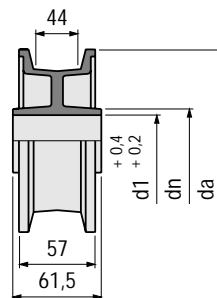

NSXT 820



only for Series 881 - 8811 (BEVEL)

Thermoplastic (NXT) Idler Wheels

Rexnord Order No.	Equivalent No. of Teeth	Outside Dia. da mm	Finished Bore d1	dn			Weight kg
				mm	L mm	Ln mm	

Bore (mm)

NXT 820 T19 R...	19	118	25 30 40	42●	57	57	0,20
NXT 820 T21 R...	21	130	25 30 35 40	d1+10	60	61,5	0,22
NXT 820 T23 R...	23	142,5	25 30 35 40 45 50	d1+10	59,5●●	61,5	0,27
NXT 820 T25 R...	25	154,5	25 30 35 40	d1+10	59	61,5	0,30

Bore (inches)

NXT 820 T19 R...*	19	118	1"	42	57	57	0,20
NXT 820 T21 R...	21	130	1 1/4" 1 1/2"	40■	60	61,5	0,22
NXT 820 T23 R...	23	142,5	1 1/4" 1 1/2"	40■	59,5	61,5	0,27
NXT 820 T25 R...	25	154,5	1 1/4" 1 1/2"	40■	59	61,5	0,30

* = Available upon request and minimum order quantity.

Material: polyamide (black).

● = 51 with d1 = 40.

●● = 61,5 with d1 = 45-50.

■ = 45 with d1 = 1 1/2".

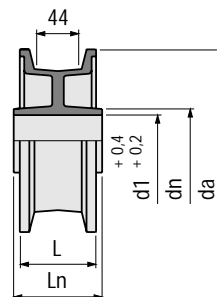

NXT 820



Example of codenumber : KSX 881 T21 R 40 (including bore)

Sprockets

for Series 820, 831, 820 Vacuum, HFP 820, XLBP 831

NS 820

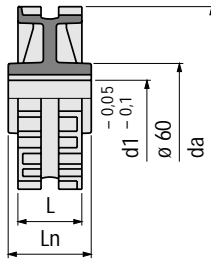

Important: cannot be used with chain 831

Split Thermoplastic (NS) Sprockets

Rexnord Order No.	No of Teeth	Pitch Dia. d mm	Outside Dia. da mm	Finished Bore with Keyway d1	L mm	Ln mm	Weight kg
-------------------	-------------	-----------------	--------------------	------------------------------	------	-------	-----------

Bore (mm)

NS 820 T21 R...	21	10,5	129,26	129,5	25 30 35 40 45	52 51	0,46
NS 820 T23 R...	23	11,5	141,22	142	25 30 35 40 45	52 51	0,54
NS 820 T25 R...	25	12,5	153,21	154,2	25 30 35 40 45	54 58,5	0,63

Bore (inch)

NS 820 T21 R...	21	10,5	129,26	129,5	1" 11/4" 2"	52 51	0,46
NS 820 T23 R...	23	11,5	141,22	142	1" 11/4" 2"	52 51	0,54
NS 820 T25 R...	25	12,5	153,21	154,2	1" 11/4" 2"	54 58,5	0,63

Material: sprocket in reinforced polyamide (black).

Keyway: UNI 6604-69. See page 101.

Bolts in stainless steel AISI 304, nuts in nickel plated brass.

Max recommended tightening torque: 1 kgm.

NS 831

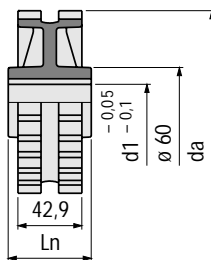

Split Thermoplastic (NS) Sprockets

Rexnord Order No.	No of Teeth	Pitch Dia. d mm	Outside Dia. da mm	Finished Bore with Keyway d1	Ln mm	Weight kg
-------------------	-------------	-----------------	--------------------	------------------------------	-------	-----------

Bore (mm)

NS 831 T21 R...*	21	10,5	129,26	129,5	25 30 35 40 45	51	0,46
NS 831 T23 R...*	23	11,5	141,22	142	25 30 35 40 45	51	0,54
NS 831 T25 R...*	25	12,5	153,21	154,2	25 30 35 40 45	58,5	0,63

Bore (inch)

NS 831 T21 R...	21	10,5	129,26	129,5	1" 11/4" 2"	51	0,46
NS 831 T23 R...	23	11,5	141,22	142	1" 11/4" 2"	51	0,54
NS 831 T25 R...	25	12,5	153,21	154,2	1" 11/4" 2"	58,5	0,63

* = Available upon request and minimum order quantity.

Keyway: UNI 6604-69. See page 101.

Material: sprocket in reinforced polyamide (black).

Max recommended tightening torque: 1 kgm.

Bolts in stainless steel AISI 304, nuts in nickel plated brass.

KUS 820

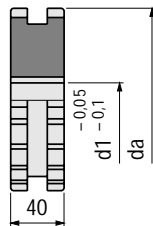

Split Thermoplastic (KUS) Sprockets

Rexnord Order No.	No of Teeth	Pitch Dia. d mm	Outside Dia. da mm	Finished Bore with Keyway d1 mm	Weight kg
KUS 820 T19 R...*	19	9,5	117,35	117	0,40
KUS 820 T21 R...*	21	10,5	129,26	129,5	0,50
KUS 820 T23 R...*	23	11,5	141,22	142	0,60
KUS 820 T25 R...*	25	12,5	153,21	154,2	0,74
KUS 820 T27 R...*	27	13,5	165,21	166	0,88

* = Available upon request and minimum order quantity.

Keyway: UNI 6604-69. See page 101.

• = Plain Bore. Without keyway. Tolerance $d1 = +0,3$ ₀

Max recommended tightening torque: 1 kgm.

Bolts and nuts in stainless steel AISI 304.

Half-section fixing nuts (self-locking).

N 820

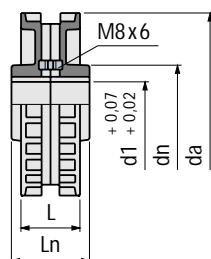

Important: cannot be used with chain 831

Thermoplastic (N) Sprockets

Rexnord Order No.	No of Teeth	Pitch Dia. d mm	Outside Dia. da mm	Finished Bore with Keyway d1 mm	dn mm	L mm	Ln mm	Weight kg
N 820 T15 R...*	15	7,5	93,67	92,2	25 30	43 50	50	0,18
N 820 T17 R...*	17	8,5	105,48	104,7	25 30	43 51	48	0,22
N 820 T19 R...*	19	9,5	117,35	117,1	20 25 30 35 40	60 50	50	0,35

* = Available upon request and minimum order quantity.

Material: sprocket in reinforced polyamide (black).

Keyway: UNI 6604-69. See page 101.

KU 820

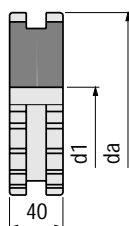

Thermoplastic (KU) Sprockets

Rexnord Order No.	No. of Teeth	Pitch Dia. d mm	Outside Dia. da mm	Plain Bore B mm	Max. Bore mm	Weight kg	
KU 820 T19 R20*	19	9,5	117,35	117	20	60	0,40
KU 820 T21 R20*	21	10,5	129,26	129	20	67	0,50
KU 820 T23 R20*	23	11,5	141,22	142	20	75	0,61
KU 820 T25 R20*	25	12,5	153,21	154	20	80	0,74
KU 820 T27 R20*	27	13,5	165,21	166	20	85	0,88

* = Available upon request and minimum order quantity.

Material: polyamide (black)

Example of codenumber : NS 820 T25 R 35 (including bore)

Sprockets

for Series 820, 831, 820 Vacuum, HFP 820, XLBP 831

Semi-Steel (GG) Sprockets

Rexnord Order No.	No. of Teeth		Pitch Dia. d mm	Outside Dia. da mm	Plain Bore B mm	dn mm	Max. Bore mm	Weight kg
	Actual	Effective						
GG 820 T19 R19	19	9,5	117,35	117	19	52	32	1,9
GG 820 T21 R19	21	10,5	129,26	129	19	64	45	2,0
GG 820 T23 R19	23	11,5	141,22	142	19	64	45	2,5
GG 820 T25 R19	25	12,5	153,21	154	19	64	50	2,7
GG 820 T27 R19*	27	13,5	165,21	166	19	72	50	6,1
GG 820 T29 R19	29	14,5	177,24	179	19	78	50	7,1
GG 820 T31 R19*	31	15,5	189,27	191	19	78	50	3,2
GG 820 T41 R19*	41	20,5	249,59	252	19	105	50	6,7

* = Available upon request and minimum order quantity.

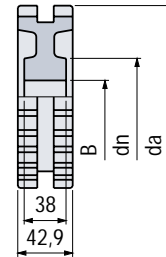

GG 820



Idler heels

for Series 820, 831, 820 Vacuum, HFP 820, XLBP 831

Split Thermoplastic (NSXT) Idler Wheels

Rexnord Order No.	Equivalent No. of Teeth	Outside Dia. da mm	Finished Bore d1 mm	dn (mm)		Weight kg
				d1= 25-30	d1= 35-45	
NSXT 820 T21 R...	21	130	25 30 35 40	40	50	0,26
NSXT 820 T23 R...*	23	142,5	25 30 35 40	40	50	0,29
NSXT 820 T25 R...	25	154,5	25 30 35 40 45	40	50	0,30

* = Available upon request and minimum order quantity.
 Material: polyamide (black).
 Also available in Glistamide® black (special material).
 Bolts and nuts in stainless steel AISI 304.
 Max recommended tightening torque: 0,6 kgm.

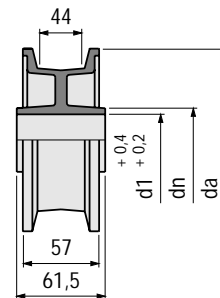

NSXT 820



Thermoplastic (NXT) Idler Wheels

Rexnord Order No.	Equivalent No. of Teeth	Outside Dia. da mm	Finished Bore d1	dn mm	L mm	Ln mm	Weight kg
NXT 820 T15 R...	15	95,5	25 30	40	55	92	0,20
NXT 820 T17 R...	17	106,5	25 30	42	53	57	0,18
NXT 820 T18 R...*	18	113	25 30	40	57	92	0,24
NXT 820 T19 R...	19	118	25 30 40	42●	57	57	0,20
NXT 820 T21 R...	21	130	25 30 35 40	d1+10	60	61,5	0,22
NXT 820 T23 R...	23	142,5	25 30 35 40 45 50	d1+10	59,5●●	61,5	0,27
NXT 820 T25 R...	25	154,5	25 30 35 40	d1+10	59	61,5	0,30

Bore (inches)		da	d1	dn	L	Ln	Weight kg
NXT 820 T19 R...*	19						
NXT 820 T21 R...	21	130	1 1/4" 1 1/2"	40■	60	61,5	0,22
NXT 820 T23 R...	23	142,5	1 1/4" 1 1/2"	40■	59,5	61,5	0,27
NXT 820 T25 R...	25	154,5	1 1/4" 1 1/2"	40■	59	61,5	0,30

* = Available upon request and minimum order quantity.
 ● = 51 with d1 = 40.
 ●● = 61,5 with d1 = 45-50.
 ■ = 45 with d1 = 1 1/2".
 Material: polyamide (black).

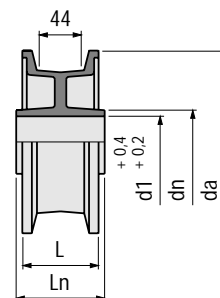

NXT 820



Example of codenumber : NSXT 820 T25 R 35 (including bore)

Sprockets

for Series 821, HFP 821, HFP 821 F, SLBP 821

NS 821

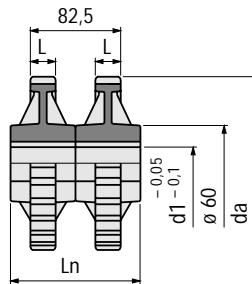

Split Thermoplastic (NS) Sprockets

Rexnord Order No.	No of Teeth	Pitch Dia. d	Outside Dia. da	Finished Bore with Keyway d1	L	Ln	Weight kg
	Actual	Effective	mm	mm	mm	mm	

Bore (mm)

NS 821 T21 R...	21	10,5	129,26	129,5	35	40 45	0,38
NS 821 T23 R...	23	11,5	141,22	142	35	40 45	0,38
NS 821 T25 R...	25	12,5	153,21	154,2	35	40 45	0,52

Bore (inch)

NS 821 T21 R...	21	10,5	129,26	129,5	1" 11/4"	31 103	0,38
NS 821 T23 R...	23	11,5	141,22	142	1"	31 103	0,38
NS 821 T25 R...	25	12,5	153,21	154,2	1" 11/4"	33 117	0,52

Material: sprocket in reinforced polyamide (black).
Bolts in stainless steel AISI 304, nuts in nickel plated brass.

Keyway: UNI 6604-69. See page 101.

Max recommended tightening torque: 1 kgm.
The sprocket consists of four sections.



KUS 821

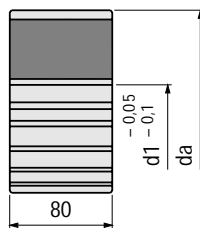

Split Thermoplastic (KUS) Sprockets

Rexnord Order No.	No of Teeth	Pitch Dia. d	Outside Dia. da	Finished Bore with Keyway d1	Weight kg
	Actual	Effective	mm	mm	

* = Available upon request and minimum order quantity.

• = Plain Bore. Without keyway. Tolerance d1 = $+0,3$ ₀
Material: sprocket in polyamide (black).
Bolts and nuts in stainless steel AISI 304.

Keyway: UNI 6604-69. See page 101.

Max recommended tightening torque: 1 kgm.
Half-section fixing nuts (self-locking).

N 821

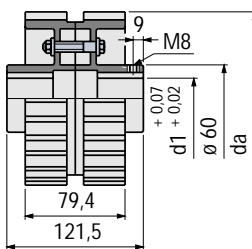

Thermoplastic (N) Sprockets

Rexnord Order No.	No of Teeth	Pitch Dia. d	Outside Dia. da	Finished Bore with Keyway d1	Weight kg
	Actual	Effective	mm	mm	

Material: polyamide (black).

Keyway: UNI 6604-69. See page 101.

KU 821

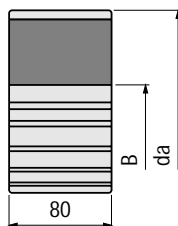

Thermoplastic (KU) Sprockets

Rexnord Order No.	No. of Teeth	Pitch Dia. d	Outside Dia. da	Plain Bore B	Max. Bore	Weight kg
	Actual	Effective	mm	mm	mm	

* = Available upon request and minimum order quantity.

Material: polyamide (black)

GG 821

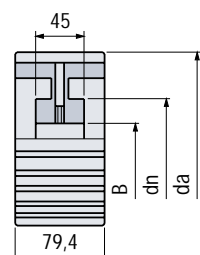

Semi-Steel (GG) Sprockets

Rexnord Order No.	No. of Teeth	Pitch Dia. d	Outside Dia. da	Plain Bore B	dn	Max. Bore	Weight kg
	Actual	Effective	mm	mm	mm	mm	

* = Available upon request and minimum order quantity.

Example of codenumber : KUS 821 T25 R 35 (including bore)

Idler Wheels

for Series 821, HFP 821, HFP 821 F, SLBP 821

Split Thermoplastic (NSX) Idler Wheels

Rexnord Order No.	No of Teeth		Pitch Dia. d mm	Outside Dia. da mm	Finished Bore d1 mm	L mm	Ln mm	Weight kg
	Actual	Effective						
NSX 821 T21 R...	21	10,5	129,26	129,5	30 35 40	31	103	0,38
NSX 821 T23 R...	23	11,5	141,22	142	30 35 40	31	103	0,38
NSX 821 T25 R...	25	12,5	153,21	154,2	30 35 40	33	117	0,43

Material: sprocket in polyamide (black).
Bolts in stainless steel AISI 304, nuts in nickel plated brass.
Max recommended tightening torque: 0,6 kgm.

The wheel consists of four sections.

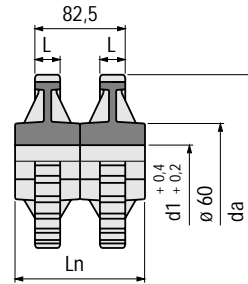
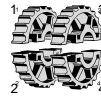

NSX 821



Thermoplastic (NXT) Idler Wheels

Rexnord Order No.	Equivalent No. of Teeth	Outside Dia. da mm	Finished Bore d1 mm	Weight kg
NXT 821 T25 R...	25	154,7	30 35	0,75

Material: polyamide (black)
Half-sections fixing screws in stainless steel AISI 304

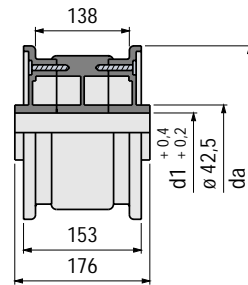

NXT 821



Example of codenumber : NXT 821 T25 R 35 (including bore)

Sprockets

for Series 879, 879BO, 879TAB, 880, 880MG, 880TAB, 880TAB-K454, 880BO, 880BOF, 880BOGB, 880GB, 880TAB Vacuum, HFP 879BO, HFP 880BOT, HFP 880TAB, LBP 879BO

NS 880

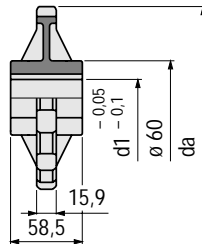

Split Thermoplastic (NS) Sprockets

Rexnord Order No.	No of Teeth	Pitch Dia. d mm	Outside Dia. da mm	Finished Bore with Keyway d1	Weight kg
	Actual	Effective			

Bore (mm)

NS880T10R...*	10	10	123,29	122,5	25 30 35 40 45	0,30
NS880T12R...*	12	12	147,21	147,4	25 30 35 40 45	0,37

Bore (inch)

NS880T12R...*	12	12	147,21	147,4	1" 11/4"	0,37
---------------	----	----	--------	-------	----------	------

* = Available upon request and minimum order quantity.
Material: sprocket in reinforced polyamide (black).
Bolts in stainless steel AISI 304, nuts in nickel plated brass.

Keyway: UNI 6604-69. See page 101.
Max recommended tightening torque: 1 kgm.

KU 880

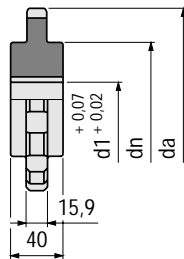

Thermoplastic (KU) Sprockets

Rexnord Order No.	No of Teeth	Pitch Dia. d mm	Outside Dia. da mm	Finished Bore with Keyway d1 mm	dn mm	Weight kg
KU880T10R...*	10	10	123,29	122,5	20 [●] 30 35 40	80 0,28
KU880T11R...*	11	11	135,23	135	20 [●] 30 35 40	85 0,35
KU880T12R...*	12	12	147,21	147,4	20 [●] 30 35 40	90 0,42

* = Available upon request and minimum order quantity.
● = Plain Bore. Without keyway. Tolerance d1 = $\begin{matrix} +0,3 \\ 0 \end{matrix}$
Material: polyamide (black).

Keyway: UNI 6604-69. See page 101.

GG 880

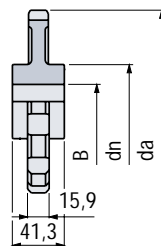

Semi-Steel (GG) Sprockets

Rexnord Order No.	No. of Teeth	Pitch Dia. d mm	Outside Dia. da mm	Plain Bore B mm	dn mm	Max. Bore mm	Weight kg
GG880T09R19*	9	9	111,40	110	19	65	45 1,3
GG880T10R19*	10	10	123,29	122	19	52	45 1,4
GG880T11R19*	11	11	135,23	136	19	65	45 1,5
GG880T12R19	12	12	147,21	147	19	-	45 1,6
GG880T15R19*	15	15	183,25	184	19	65	45 1,9

* = Available upon request and minimum order quantity.

Example of codenumber : NS 880 T12 R 35 (including bore)

Idler Wheels

for Series 879, 879 BO, 879 TAB, 880, 880 MG, 880 TAB, 880 TAB-K454, 880 BO, 880 BO F, 880 BO GB, 880 GB, 880 TAB Vacuum, HFP 879 BO, HFP 880 BOT, HFP 880 TAB, LBP 879 BO

Split Thermoplastic (NSX) Idler Wheels

Rexnord Order No.	No of Teeth		Pitch Dia. d mm	Outside Dia. da mm	Finished Bore d1 mm			Weight kg
	Actual	Effective			20	25	30 35	
NSX 880 T10 R...*	10	10	123,29	122,5	20	25	30 35	0,30
NSX 880 T12 R...*	12	12	147,21	147,4	25	30	35	0,37

* = Available upon request and minimum order quantity.
 Material: wheel in polyamide (black).
 Bolts in stainless steel AISI 304, nuts in nickel plated brass.
 Max recommended tightening torque: 0,6 kgm.

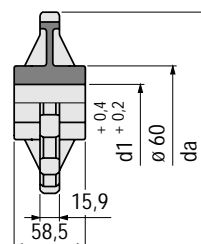

NSX 880



Thermoplastic (NX) Idler Wheels

Rexnord Order No.	No of Teeth		Pitch Dia. d mm	Outside Dia. da mm	Finished Bore d1 mm	Weight kg
NX 880 T12 R...	12	12	147,21	147,4	30 35	0,30

Material: polyamide (black).

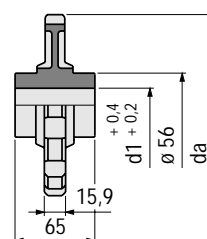

NX 880



only for Series 879-880 - (BEVEL)

Split Thermoplastic (NSXT) Idler Wheels

Rexnord Order No.	Equivalent No. of Teeth	Outside Dia. da mm	Finished Bore d1 mm				dn (mm)		Weight kg
			25	30	35	40	d1= 25-30	d1= 35-45	
NSXT 820 T21 R...	10	130	25	30	35	40	40	50	0,26
NSXT 820 T23 R...*	11	142,5	25	30	35	40	40	50	0,29
NSXT 820 T25 R...	12	154,5	25	30	35	40 45	40	50	0,30

* = Available upon request and minimum order quantity.
 Material: polyamide (black).
 Also available in Glistamide® black (special material).
 Bolts and nuts in stainless steel AISI 304.
 Max recommended tightening torque: 0,6 kgm.

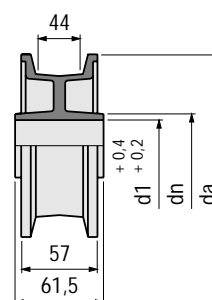

NSXT 820



only for Series 879-880 - (BEVEL)

Thermoplastic (NXT) Idler Wheels

Rexnord Order No.	Equivalent No. of Teeth	Outside Dia. da mm	Finished Bore d1	dn			Weight kg
				mm	L mm	Ln mm	

Bore (mm)

NXT 820 T19 R...	19	118	25 30 40	42●	57	57	0,20
NXT 820 T21 R...	21	130	25 30 35 40	d1+10	60	61,5	0,22
NXT 820 T23 R...	23	142,5	25 30 35 40 45 50	d1+10	59,5●●	61,5	0,27
NXT 820 T25 R...	25	154,5	25 30 35 40	d1+10	59	61,5	0,30

Bore (inches)

NXT 820 T19 R...*	19	118	1"	42	57	57	0,20
NXT 820 T21 R...	21	130	1 1/4" 1 1/2"	40■	60	61,5	0,22
NXT 820 T23 R...	23	142,5	1 1/4" 1 1/2"	40■	59,5	61,5	0,27
NXT 820 T25 R...	25	154,5	1 1/4" 1 1/2"	40■	59	61,5	0,30

* = Available upon request and minimum order quantity.
 ● = 51 with d1= 40.
 ●● = 61,5 with d1= 45-50.
 ■ = 45 with d1 = 1 1/2".
 Material: polyamide (black).

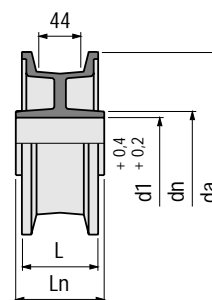

NXT 820



Example of codenumber : NSXT 820 T25 R 40 (including bore)

Sprockets

for Series 882, 882 TAB, HFP 882 TAB, HFP 882 TAB F, SLBP 882 TAB, LBP 883, RR 882

NS 882

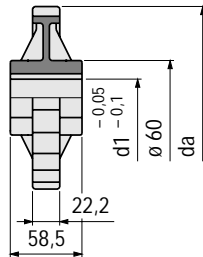

Split Thermoplastic (NS) Sprockets

Rexnord Order No.	No of Teeth		Pitch Dia. d mm	Outside Dia. da mm	Finished Bore with Keyway d1	Weight kg
-------------------	-------------	--	-----------------	--------------------	------------------------------	-----------

Bore (mm)

NS 882 T12 R...*	12	12	147,21	149,9	25 30 35 40 45	0,37
------------------	----	----	--------	-------	----------------	------

Bore (inch)

NS 882 T12 R...*	12	12	147,21	149,9	1"	0,37
------------------	----	----	--------	-------	----	------

* = Available upon request and minimum order quantity.

Keyway: UNI 6604-69. See page 101.

Max recommended tightening torque: 1 kgm.

Material: sprocket in reinforced polyamide (black).
Bolts in stainless steel AISI 304, nuts in nickel plated brass.

KU 882

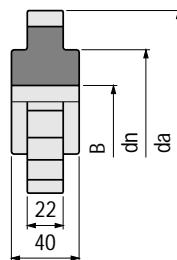

Thermoplastic (KU) Sprockets

Rexnord Order No.	No of Teeth		Pitch Dia. d mm	Outside Dia. da mm	Plain Bore B mm	dn mm	Weight kg
KU 882 T09 R20	9	9	111,4	112	20	64	0,46

Material: polyamide (black).

GG 882

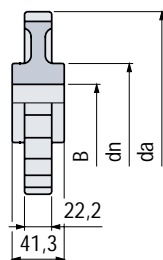

Semi-Steel (GG) Sprockets

Rexnord Order No.	No. of Teeth		Pitch Dia. d mm	Outside Dia. da mm	Plain Bore B mm	dn mm	Max. Bore mm	Weight kg
GG 882 T09 R19*	9	9	111,4	112	19	65	45	1,7
GG 882 T10 R19	10	10	123,29	125	19	61	45	1,9
GG 882 T11 R19*	11	11	135,23	137	19	-	45	2,0
GG 882 T12 R19*	12	12	147,21	149	19	-	45	2,1

* = Available upon request and minimum order quantity.

Example of codenumber : NS 882 T12 R 35 (including bore)

Idler Wheels

for Series 882, 882 TAB, HFP 882 TAB, HFP 882 TAB F,
SLBP 882 TAB, LBP 883, RR 882

Split Thermoplastic (NSX) Idler Wheels

Rexnord Order No.	No of Teeth		Pitch Dia. d mm	Outside Dia. da mm	Finished Bore d1	Weight kg
	Actual	Effective				

Bore (mm)

NSX 882 T12 R...*	12	12	147,21	149,9	25 30 35 40	0,37
-------------------	----	----	--------	-------	-------------	------

Bore (inch)

NSX 882 T12 R...	12	12	147,21	149,9	1"	0,37
------------------	----	----	--------	-------	----	------

* = Available upon request and minimum order quantity.

Material: wheel in polyamide (black).

Bolts in stainless steel AISI 304, nuts in nickel plated brass.

Max recommended tightening torque: 0,6 kgm.

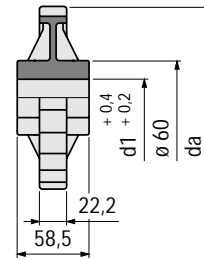

NSX 882



Sprockets

for Series FGM 1050, FTM 1050, FTM 1055

NS 1050

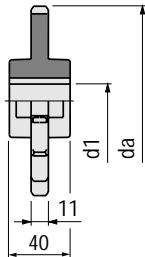

Split Thermoplastic (NS) Sprockets

Rexnord Order No.	No of Teeth		Pitch Dia. d mm	Outside Dia. da mm	Finished Bore with Keyway d1	Weight kg
	Actual	Effective				
Bore (mm)						
KUS 1050 T16 R...	16	16	131,2	130,9	30 40	0,20
KUS 1050 T18 R...	18	18	147,4	146,8	30 40	0,21
Bore (inch)						
KUS 1050 T16 R...	16	16	131,2	130,9	1 1/2"	0,20
KUS 1050 T18 R...	18	18	147,4	146,8	1 1/2"	0,21

Material: sprocket in reinforced polyamide (black).
Bolts and nuts in stainless steel AISI 304.
Keyway: UNI 6604-69. See page 101.

KUS 1050

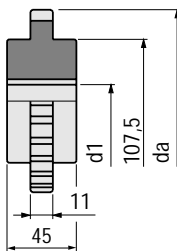

Split Thermoplastic (KUS) Sprockets

Rexnord Order No.	No of Teeth		Pitch Dia. d mm	Outside Dia. da mm	Finished Bore with Keyway d1	Weight kg
	Actual	Effective				
Bore (mm)						
KUS 1050 T16 R...	16	16	131,2	130,9	25 30 35 40 50	0,45
KUS 1050 T18 R...	18	18	147,4	146,8	25 30 35 40 50	0,50
Bore (inch)						
KUS 1050 T16 R...	16	16	131,2	130,9	1" 13/16" 1 1/4" 1 7/16" 1 1/2"	0,45
KUS 1050 T18 R...	18	18	147,4	146,8	1" 13/16" 1 1/4" 1 7/16" 1 1/2"	0,50

Material: sprocket in polyamide (white). Bolts and nuts in stainless steel AISI 304.
Keyway: UNI 6604-69. See page 101.

Idler Wheels

for Series FGM 1050, FTM 1050, FTM 1055

NSX1050

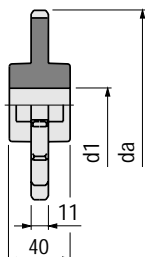

Split Thermoplastic (NSX) Idler Wheels

Rexnord Order No.	No of Teeth		Pitch Dia. d mm	Outside Dia. da mm	Finished Bore d1	Weight kg
	Actual	Effective				
Bore (mm)						
KUS 1050 T16 R...	16	16	131,2	130,9	30 40	0,20
KUS 1050 T18 R...	18	18	147,4	146,8	30 40	0,21
Bore (inch)						
KUS 1050 T16 R...	16	16	131,2	130,9	1 1/2"	0,20
KUS 1050 T18 R...	18	18	147,4	146,8	1 1/2"	0,21

Material: wheel in polyamide (black).
Bolts and nuts in stainless steel AISI 304.

Example of codenumber : KUS 1050 T16 R 35 (including bore)

Sprockets

for Series A 600, A 600 TAB

Thermoplastic (KU) Sprockets

Rexnord Order No.	No of Teeth	Pitch Dia. d mm	Outside Dia. da mm	Finished Bore with Keyway d1 mm	dn mm	Weight kg
KU 600 T06 R20*	6	127	128	20 [●]	74	0,36
KU 600 T08 R20*	8	165,93	177,7	20 [●]	119	0,65
KU 600 T10 R....	10	205,49	219,3	20 [●] 35	161	1,30

* = Available upon request and minimum order quantity.
 ● = Plain Bore. Without keyway. Tolerance d1 = $\begin{matrix} +0,3 \\ 0 \end{matrix}$
 Material: polyamide (black)
 Keyway: UNI 6604-69. See page 101.

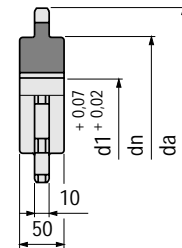

KU 600



Semi-Steel (GG) Sprockets

Rexnord Order No.	No of Teeth	Pitch Dia. d mm	Outside Dia. da mm	Plain Bore B mm	dn mm	Ln mm	Weight kg
GG 600 T08 R19*	8	167,4	175,3	19	75	50	3,4
GG 600 T10 R19*	10	207,3	216,0	19	100	50	5,7
GG 600 T12 R19*	12	247,4	254,0	19	100	63,5	8,2
GG 600 T14 R19*	14	287,8	294,6	19	100	63,5	9,0

* = Available upon request and minimum order quantity.

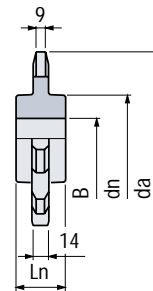

GG 600



for Series A 1400, A 1400 TAB

Semi-Steel (GG) Sprockets

Rexnord Order No.	No. of Teeth	Pitch Dia. d mm	Outside Dia. da mm	Plain Bore B mm	dn mm	Weight kg
GG 1400 T10 R19*	10	267,20	298,0	24	105	13,3

* = Available upon request and minimum order quantity.

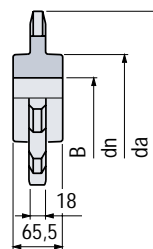

GG 1400



Sprockets

for Series 1700 K, 1700 TAB K, AC 1700 K, 1702, 1710 K, 1710 TAB K, 1713 K, 1713 TAB K, 1716 K, 1720 K, 1790 K, 1790 TAB K, 1765 ZeroGap™

N 1700

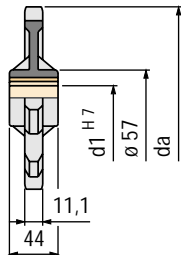

Thermoplastic (N) Sprockets

Rexnord Order No.	No of Teeth	Pitch Dia. d mm	Outside Dia. da mm	Finished Bore with Keyway d1 mm	Weight kg
N 1700 T10 R...	10	161,8	165,1	24 25 30	0,42

Material: polyamide (white). Brass hub.
Keyway: UNI 6604-69. See page 101.

N 1700 AS

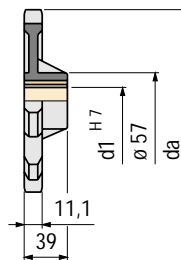

Thermoplastic (N) Sprockets

Rexnord Order No.	No of Teeth	Pitch Dia. d mm	Outside Dia. da mm	Finished Bore with Keyway d1 mm	Weight kg
N 1700 AS T10 R...*	10	161,8	165,1	24 25 30	0,40

* = Available upon request and minimum order quantity.

Material: polyamide (white). Brass hub.
Keyway: UNI 6604-69. See page 101.

KU 1700

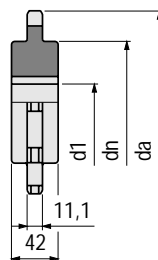

Thermoplastic (KU) Sprockets

Rexnord Order No.	No of Teeth	Pitch Dia. d mm	Outside Dia. da mm	Finished Bore with Keyway d1 mm	dn mm	Weight kg
KU 1700 T08 R...	8	130,65	132,8	19 • 25	79	0,30
KU 1700 T10 R19	10	161,80	165,1	19 •	110	0,54
KU 1700 T13 R19	13	208,95	215,2	19 •	158	1,07

• = Plain Bore. Without keyway.

Material: polyamide (white).

ZN 1700 AS SS 1700 AS

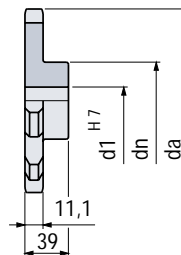

Steel Sprockets

Rexnord Order No. Zinc plated steel	Rexnord Order No. Stainless steel AISI 304	No of Teeth	Pitch Dia. d mm	Outside Dia. da mm	Finished Bore d1 mm	dn mm	Weight kg
ZN 1700 AS T10 R20*	SS 1700 AS T10 R20*	10	161,8	165,1	20	69 (60*)	2,25
ZN 1700 AS T12 R20*	-	12	193,19	196,1	20	69	2,95

* = Available upon request and minimum order quantity.

• = only for stainless steel versions

ZN 1700 SS 1700

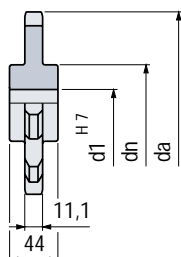

Steel Sprockets

Rexnord Order No. Zinc plated steel	Rexnord Order No. Stainless steel AISI 304	No of Teeth	Pitch Dia. d mm	Outside Dia. da mm	Finished Bore d1 mm	dn mm	Weight kg
ZN 1700 T10 R20*	SS 1700 T10 R20*	10	161,8	165,1	20	69 (60*)	2,42
ZN 1700 T12 R20*	-	12	193,19	196,1	20	69	2,95

* = Available upon request and minimum order quantity.

• = only for stainless steel versions

Example of codenumber : N 1700 AS T10 R 30 (including bore)

Idler Wheels

for Series 1700K, 1700 TABK, AC 1700K, 1702, 1710K, 1710 TABK, 1713K, 1713 TABK, 1716K, 1720K, 1790K, 1790 TABK, 1765 ZeroGap™

Thermoplastic (NX) Idler Wheels

Rexnord Order No.	No of Teeth	Pitch Dia. d mm	Outside Dia. da mm	Finished Bore d1 mm	Weight kg
NX 1700 T10 R25	10	161,8	165,1	25	0,23

Material: polyamide (white)

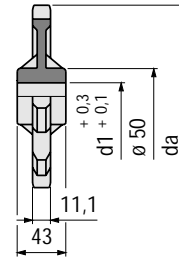

NX 1700



Thermoplastic (NX) Idler Wheels

Rexnord Order No.	No of Teeth	Pitch Dia. d mm	Outside Dia. da mm	Finished Bore d1 mm	Weight kg
NX 1700 AST10 R25*	10	161,8	165,1	25	0,23

* = Available upon request and minimum order quantity.
Material: polyamide (white)

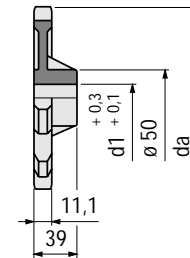

NX 1700 AS



Sprockets

for Series 1755

Semi-Steel (GG) Sprockets

Rexnord Order No.	No. of Teeth	Pitch Dia. d mm	Outside Dia. da mm	Plain Bore B mm	Max. Bore mm	Weight kg
GG 1755 T13 R19*	13	167,14	172,2	19	30	2,6
GG 1755 T16 R19*	16	205,03	210	19	30	3,5

* = Available upon request and minimum order quantity.

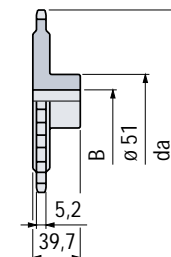

GG 1755



for Series 3150

Aluminium (AL) Sprockets

Rexnord Order No.	No. of Teeth	Pitch Dia. d mm	Outside Dia. da mm	Finished Bore with Keyway d1 mm	Weight kg
AL 3150 T12 R35*	12	309,1	308	35	2,94

* = Available upon request and minimum order quantity.
Material: hub in plastic-coated steel
Keyway: UNI 6604-69. See page 101.

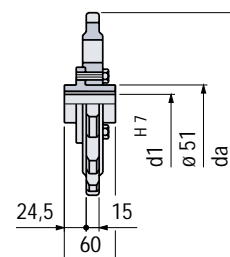

AL 3150



Sprockets

for Series 1108

Thermoplastic (N) Sprockets and (NX) Idler Wheels

N 1108
NX 1108

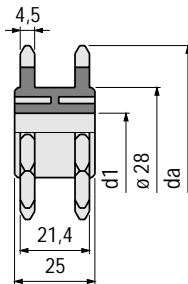

Rexnord Order No. Sprocket	Rexnord Order No. Idler Wheel	No of Teeth Actual	No of Teeth Effective	Pitch Dia. d mm	Outside Dia. da mm	Finished Bore d1 mm		Weight kg
N1108T12R12*	NX1108T12R12*	12	12	49,07	54	12 ^{+0,05} ₀	12 ^{+0,4} _{+0,2}	0,02

* = Available upon request and minimum order quantity.

Material: polyamide (black)

Drive sprocket shaft fixing system: key pin

for Series 1080

Steel (ST) Sprockets

ST 1080

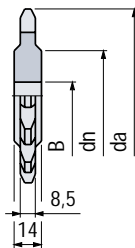

Rexnord Order No.	No of Teeth	Pitch Dia. d mm	Outside Dia. da mm	dn mm	Plain Bore B mm	Weight kg
ST1080T08R30*	8	165,93	188,63	119	30	1,64
ST1080T09R30*	9	185,67	210	136	30	2,00
ST1080T10R30*	10	205,50	231	158	30	3,00
ST1080T12R30*	12	245,35	272,4	200	30	3,98
ST1080T14R30*	14	285,36	313,6	240	30	6,20

* = Available upon request and minimum order quantity.

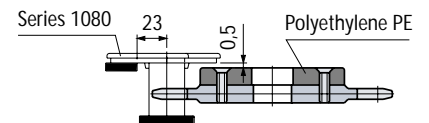

Drive and Idler Disc

The use of lateral curving discs makes possible the design of compact conveying systems with a greater number of curves. It becomes easy to realise rings either on the same plane or staggered, upgrading or downgrading runs, practically without any limit.

for Series 879 BO, 880 BO, 880 BO GB, 880 BO F, HFP 879 BO, HFP 880 BOT, LBP 879 BO

Thermoplastic (N) Corner Disc

Rexnord Order No. Drive	Rexnord Order No. Return	No of Teeth	Outside Dia. da mm	Weight kg
N 880 BO T32	NX 880 BO T32	32	352	0,98

Material: corner disc in reinforced polyamide (black).
Brass hub.

Assembly scheme

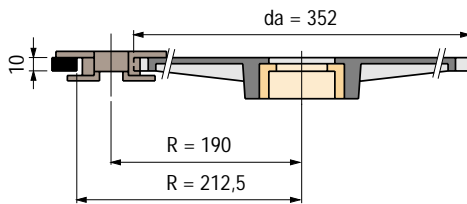

Drive section

Example of friction type shaft fixing. The device is tightened to generate the friction necessary to transmit drive.

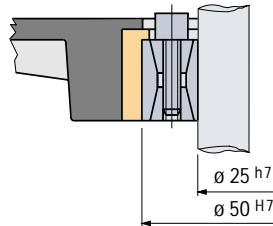

Return section

Closed version

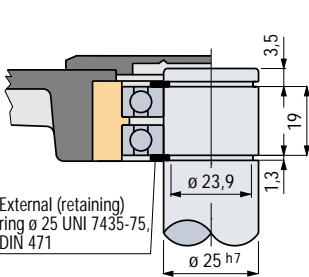

Open version. Can be obtained from closed version by breaking out the diaphragm.

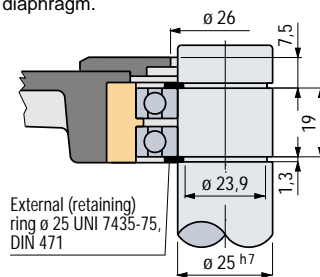

Thermoplastic (N) Corner Disc

Rexnord Order No.	Outside Dia. da mm	Weight kg
NXT 880 BO	334,6	0,98

Material: corner disc in reinforced polyamide (black).
Brass hub.

Closed version

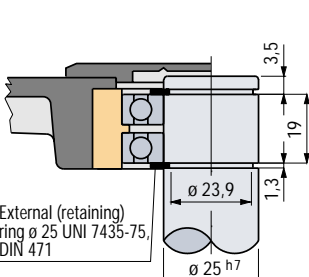

Open version. Can be obtained from closed version by breaking out the diaphragm.

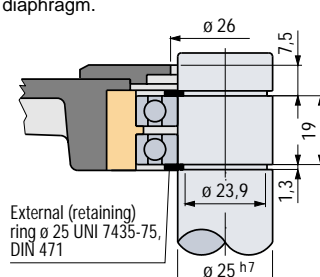

N 880 BO NX 880 BO

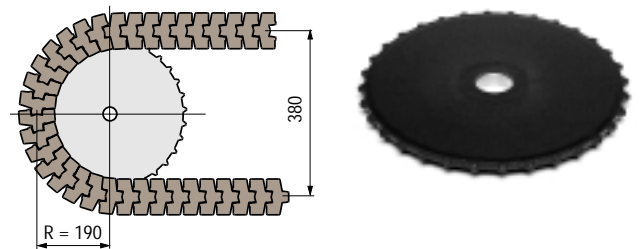

Drive

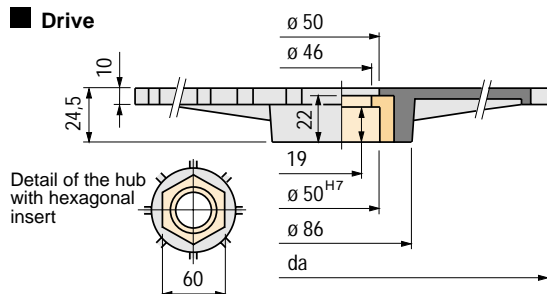

Return

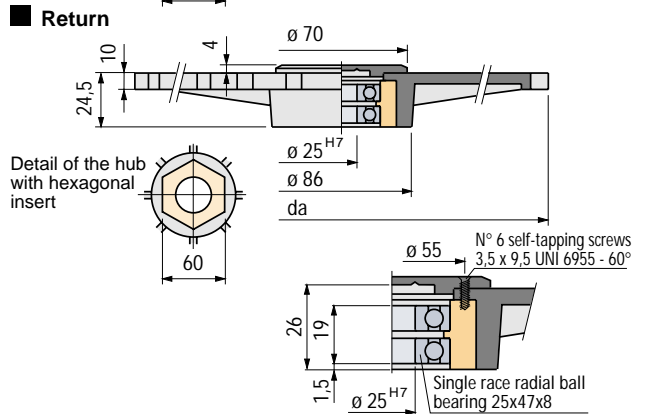

NXT 880 BO

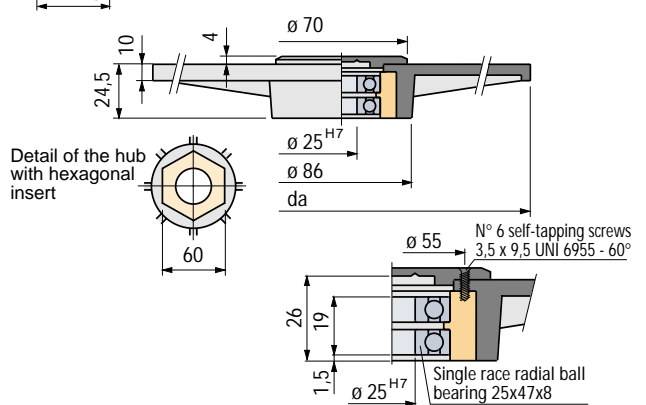
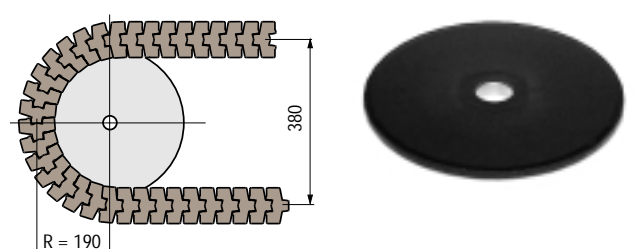

Multiflex Corner Discs

for Series 1700K, 1700TABK, AC1700K, 1710K, 1710TABK,
1720K, 1765 ZeroGap™

ND1700B



Thermoplastic Corner Discs, with bearings

Rexnord Order No. Carry	Rexnord Order No. Return	Version	Weight kg
----------------------------	-----------------------------	---------	--------------

Corner discs for Series 1700K, AC1700K, 1710K, 1720K, 1765 ZeroGap™

ND 1700 BC - TR	ND 1700 BC - RET *	Closed	0,70
ND 1700 BO - TR *	ND 1700 BO - RET	Open	

Corner discs for Series 1700TABK, 1710TABK

ND 1700 TBC - TR *	ND 1700 TBC - RET *	Closed	0,70
ND 1700 TBO - TR *	ND 1700 TBO - RET *	Open	

* = Available upon request and minimum order quantity.
Material: reinforced polyamide (black)

Carry

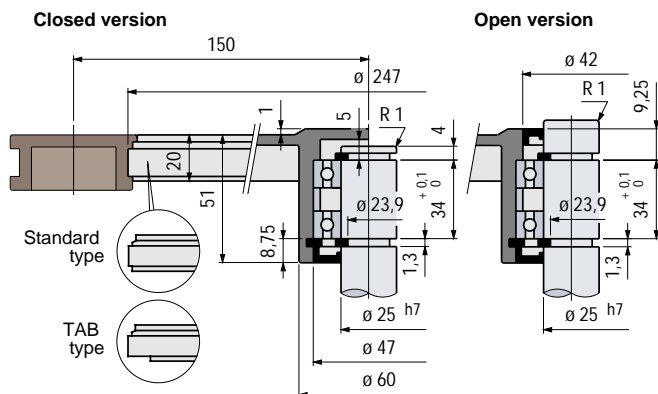

Return

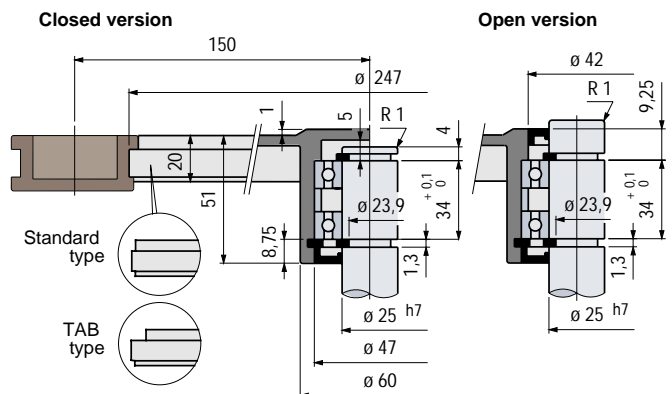

Used for chain type

1700K - 1720K
1765 ZeroGap™

AC1700K

1710K

1700TABK

1710TABK

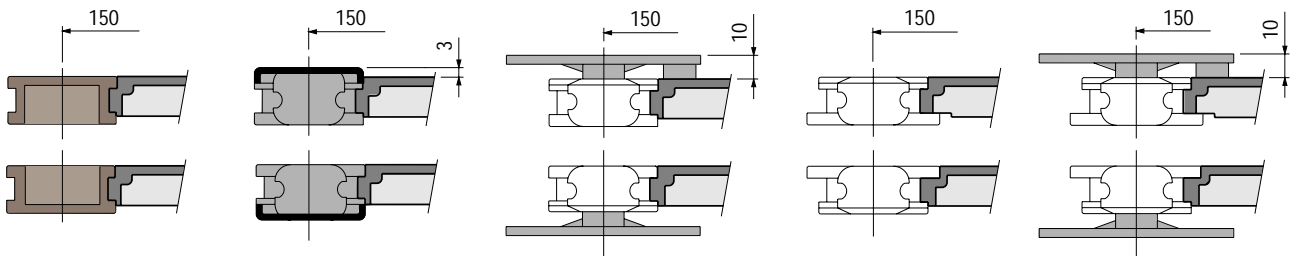

Components

Closed versions

Open versions

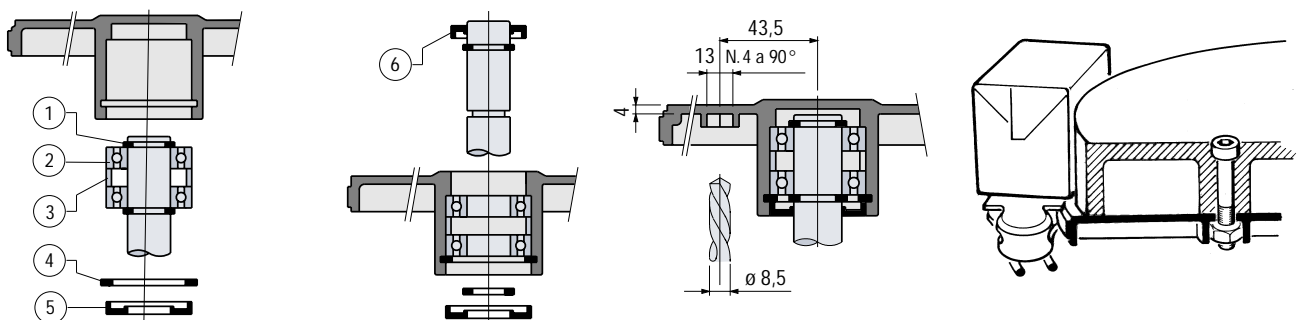

- 1- External (retaining) ring, $\varnothing 25$ DIN 471
- 2- Single race radial ball bearing with two sliding seals, SKF 6005 - 2RS1 (25X47X12)
- 3- Bearing spacer (brass)

- 4- Internal (retaining) ring, $\varnothing 47$ DIN 472
- 5- Seal ring with dust cover, 25X47X7, DIN 3760 (NBR rubber)
- 6- Seal ring with dust cover, 25X42X7, DIN 3760 (NBR rubber)

All components are supplied separate, except the shaft bearings which are pre-assembled

The presence of the 4 hexagonal seats permits mounting on the corner disc a disc (for example in polyamide) for product support.

Multiflex Corner Discs

for Series 1700K, 1700TABK, AC 1700K, 1710K, 1710TABK, 1720K, 1765 ZeroGap™

Thermoplastic Corner Discs, with bushing

Rexnord Order No. Carry	Rexnord Order No. Return	Used for Chain Type	Weight kg
ND 1700-TR	ND 1700-RET *	1700K - AC 1700K - 1710K - 1720K - 1765 ZeroGap™	0,47
ND 1700T-TR *	ND 1700T-RET *	1700TABK - 1710TABK	

* = Available upon request and minimum order quantity.
Material: reinforced polyamide (black). Hub bush in *Rex-HP™* (dark grey).



ND 1700

Carry

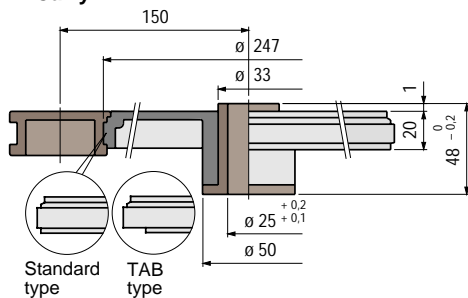

Return

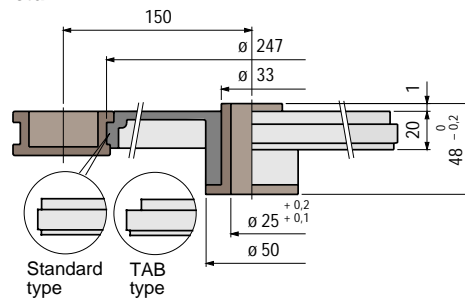

Shaft dimensions

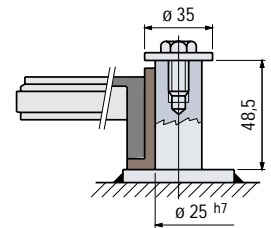

Used for chain type

1700K - 1720K
1765 ZeroGap™

AC 1700K

1710K

1700TABK

1710TABK

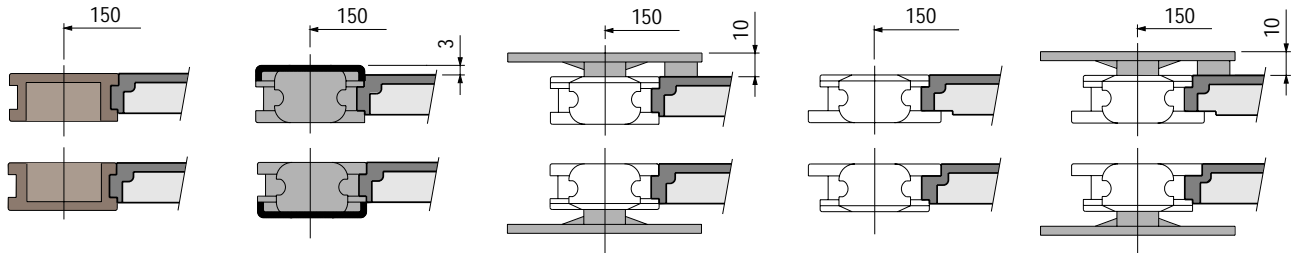

Max radial load

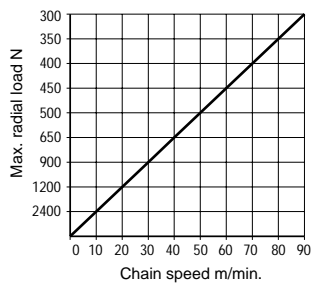

The presence of the 4 hexagonal seats permits mounting on the corner disc a disc (for example in polyamide) for product support.

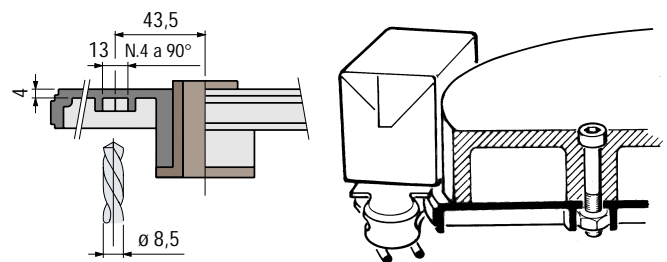

Multiflex Corner Discs

for Series 1700K, 1720K, 1765 ZeroGap™

ND 1700 FL



Thermoplastic Corner Discs, with bushing

Rexnord Order No. Carry	Rexnord Order No. Return	Used for Chain Type	Weight kg
ND 1700FL-TR *	ND 1700FL-RET *	1700 K - 1720K - 1765 ZeroGap™	0,92

* = Available upon request and minimum order quantity.
Material: reinforced polyamide (white). Hub bush in Rex-HP™ (dark grey).

■ Carry

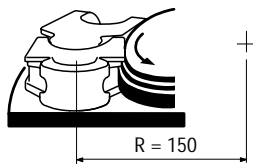
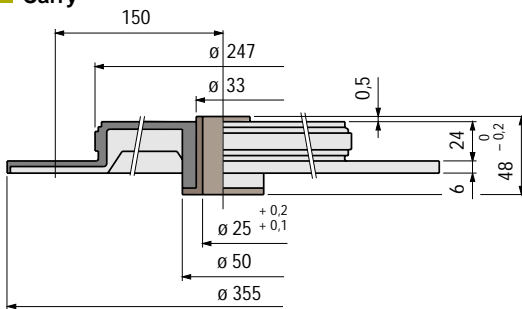

■ Return

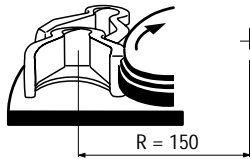
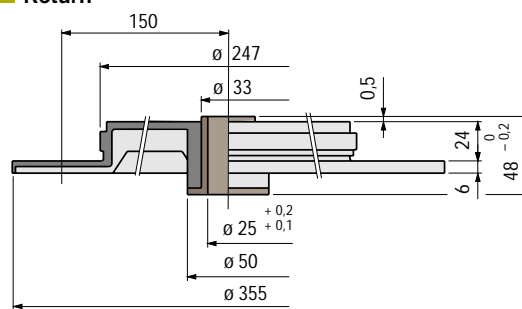

for Series 1755

KU 1755 US



Thermoplastic Corner Discs

Rexnord Order No.	Used for Chain Type	Weight kg
KU 1755- US *	1755	0,40

* = Available upon request and minimum order quantity.
Material: UHMWPE

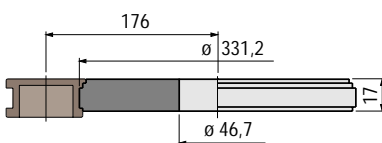

Pin Extractor

for Series 1700K, 1700TABK, AC 1700K, 1702, 1710K, 1710TABK, 1713K, 1713TABK, 1716K, 1720K, 1790K, 1790TABK, 1765 ZeroGap™

EP 1700

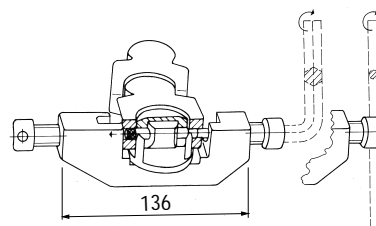
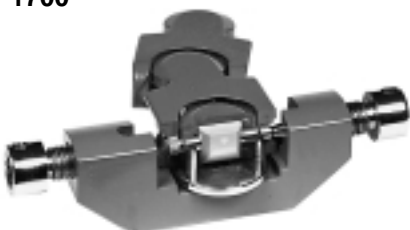

Pin extractor

Rexnord Order No.	Weight kg
EP 1700 *	0,57

* = Available upon request and minimum order quantity.
Material: body in aluminium. Extractor pins and chain centering plate made from nickel plated brass.
Use: ideal for the assembling/reassembling the pins of multiflex chains types.

Compact Corner Tracks

for Series 880, 881, 8811

Corner tracks

KSU

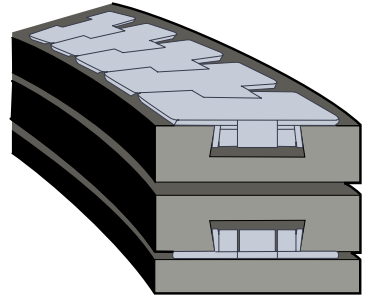
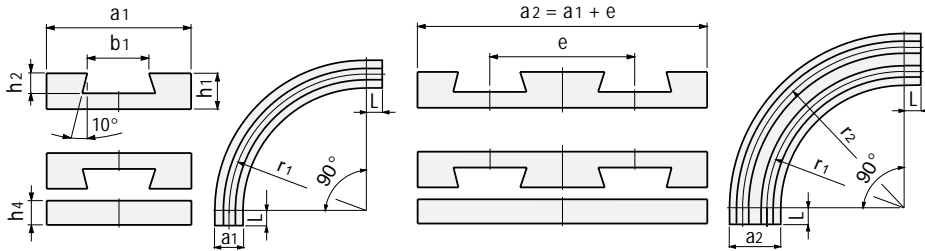

Used for Chain Type	Chain width mm	Radius r1 mm	State of supply	Width a1 mm	b1 mm ± 0.5	h1 mm	h2 mm	h4 mm	L mm	Pitch e mm	Renxord Order No.
880-K325	82,5	500	Without the L sections	100	41,4	25	18	16	-	90	KSU 013 500...
881-K325			With the L sections	100	41,4	25	17	15	50	*	KSU 013 500...S
8811-K325											
880-K450	114,3	610	Without the L sections	125	41,4	25	18	16	-	120	KSU 018 610...
881-K450			With the L sections	130	41,4	25	17	15	50	*	KSU 018 610...S
8811-K450											
881-K750	190,5	610	Without the L sections	200	41,4	25	18	16	-	195	KSU 030 610...
8811-K750			With the L sections	210	41,4	25	17	15	50	*	KSU 030 610...S

* = To be specified upon order.

Straight tracks

SSU

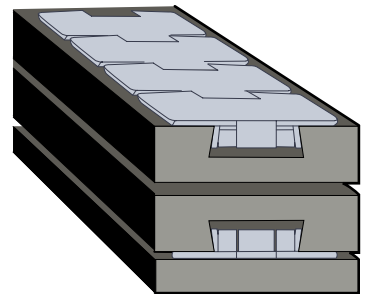
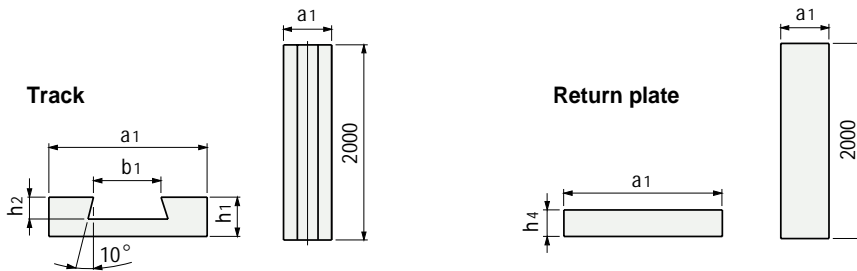

Used for Chain Type	Chain width mm	Width a1 mm	b1 mm	h1 mm	h2 mm	h4 mm	Renxord Order No. Track	Renxord Order No. Return plate
880-K325	82,5	100	41,4	25	17	15	SSU 013	SSU 013 P
881-K325								
8811-K325								
880-K450	114,3	130	41,4	25	17	15	SSU 018	SSU 018 P
881-K450								
8811-K450								

Material: polyethylene UHMWPE (black) with molecular density 1.000.000.

Standard packaging: the corner tracks are supplied complete with carry and return sections. Straight tracks are supplied as single profile 2 m long.

Special dimensions on application.

When ordering indicate the No. of strands required:

KSU 013 500 1
Code No. of strands

Linear expansion coefficient: 2×10^{-4}
Calculation of thermal expansion see page 98.

Operating temperature:

In air (-40 to +80 °C).
In hot water (+70 °C).

Positioning: see page 101.

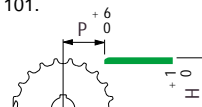

Compact Corner Tracks

for Series 882

KSU 200

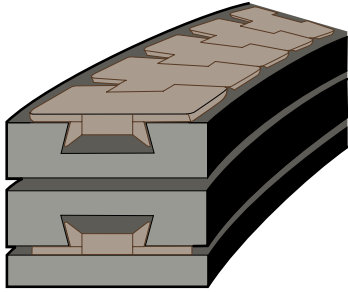

Corner tracks

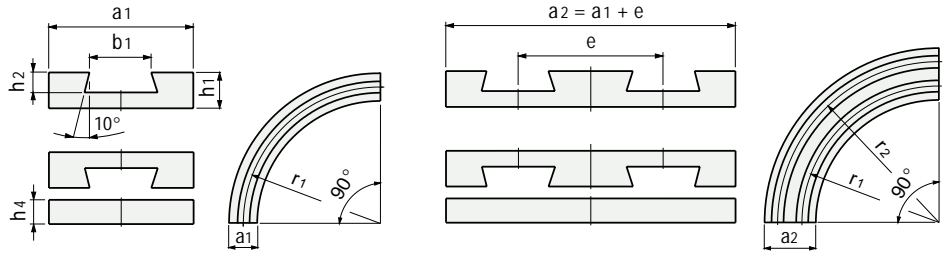

Used for Chain Type	Chain width mm	Radius r1 mm	Radius r1 mm	± 0.5 b1 mm	h1 mm	h2 mm	h4 mm	Pitch e mm	Rexnord Order No.
882 - K450	114,3	610	125	58	27	21	16	120	KSU218 610...
882 - K750	190,5	610	200	58	27	21	16	195	KSU230 610...
882 - K1000	254	610	265	58	27	21	16	260	KSU240 610...

Material: polyethylene UHMWPE (black) with molecular density 1.000.000.

Standard packaging: the corner tracks are supplied complete with carry and return sections.

Special dimensions on application.

When ordering indicate the No. of strands required:

KSU218610 1
Code No. of strands

Linear expansion coefficient: 2×10^{-4}

Calculation of thermal expansion see page 98.

Operating temperature:

In air (-40 to + 80 °C).

In hot water (+ 70 °C).

Positioning: see page 101.

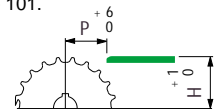

Compact Corner Tracks

for Series 879 BO, 879 TAB, 880 BO, 880 BO GB, 880 GB, 880 TAB K454,
880 TAB Vacuum, 880 TAB, 881 TAB, 8811 TAB, HFP 880 BOT, HFP 880TAB, SSC 8811 TAB,

Corner tracks

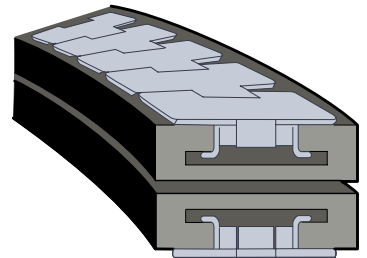
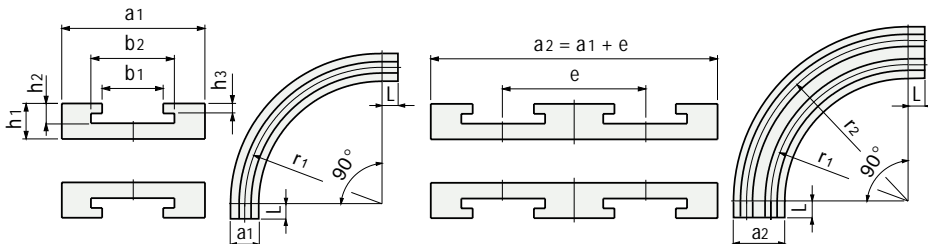

KTU

Used for Chain Type	Chain width mm	Radius r1 mm	State of supply	Width a1 mm	b1 mm	b2 mm	h1 mm	h2 mm	h3 mm	L mm	Pitch e mm	Renord Order No.
879TAB-K325	82,5	500	Without the L sections	100	45	70	25	18	9,5	-	90	KTU013500...
880TAB-K325			100	45	67	25	18	10,5	50	*	KTU013500...S	
881TAB-K325			100	45	67	25	18	10,5	50	*	KTU013500...S	
8811TAB-K325			100	45	67	25	18	10,5	50	*	KTU013500...S	
879TAB-K450	114,3	610	Without the L sections	125	45	70	25	18	9,5	-	120	KTU018610...
880TAB-K450			125	45	67	25	18	10,5	50	*	KTU018610...S	
881TAB-K450			125	45	67	25	18	10,5	50	*	KTU018610...S	
8811TAB-K450			125	45	67	25	18	10,5	50	*	KTU018610...S	
881TAB-K750	190,5	610	Without the L sections	200	45	70	25	18	9,5	-	195	KTU030610...
8811TAB-K750			200	45	67	25	18	10,5	50	*	KTU030610...S	

* = To be specified upon order.

Straight tracks

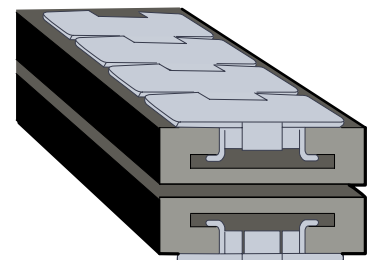
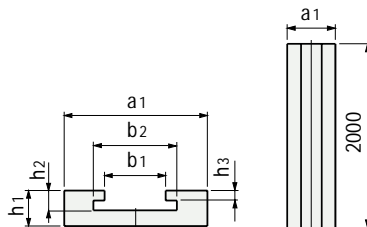

STU

Used for Chain Type	Chain width mm	Width a1 mm	b1 mm	b2 mm	h1 mm	h2 mm	h3 mm	Renord Order No.
879TAB-K325	82,5	100	45	67	25	18	10,5	STU013
879BO-K325								
880TAB-K325								
881TAB-K325								
8811TAB-K325								
879TAB-K450	114,3	130	45	67	25	18	10,5	STU018
879BO-K450								
880TAB-K450								
881TAB-K450								
8811TAB-K450								

Material: polyethylene UHMWPE (black) with molecular density 1.000.000.

Standard packaging: the corner tracks are supplied complete with carry and return sections. Straight tracks are supplied as single profile 2 m long.

Special dimensions on application.

When ordering indicate the No. of strands required:

KTU013500 1
Code | No. of strands

Linear expansion coefficient: 2×10^{-4}
Calculation of thermal expansion see page 98.

Operating temperature:
In air (-40 to +80 °C).
In hot water (+70 °C).

Positioning: see page 101.

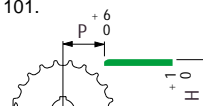

Compact Corner Tracks

for Series 882 TAB, HFP 882 TAB, HFP 882 TAB F, RR 882

KTU 200

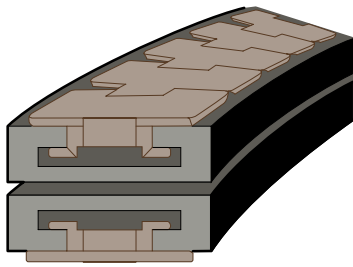

Corner tracks

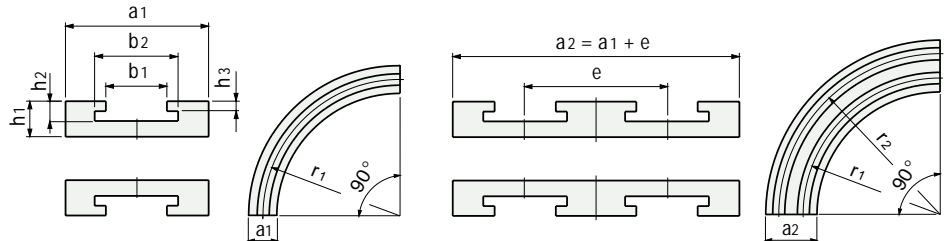

Used for Chain Type	Chain width mm	Radius r1 mm	Width a1 mm	b1 mm	b2 mm	h1 mm	h2 mm	h3 mm	Pitch e mm	Renxord Order No.
882TAB-K450	114,3	610	130	60	84	30	24	15	*	KTU 218 610...S
882TAB-K750	190,5	610	210	60	84	30	24	15	*	KTU 230 610...S
882TAB-K1000	254	610	270	60	84	30	24	15	*	KTU 240 610...S
882TAB-K1200	304,8	610	320	60	84	30	24	15	*	KTU 248 610...S

* = To be specified upon order.

STU 200

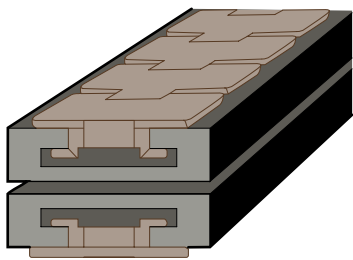

Straight tracks

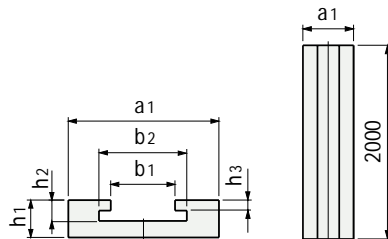

Used for Chain Type	Chain width mm	Width a1 mm	b1 mm	b2 mm	h1 mm	h2 mm	h3 mm	Renxord Order No.
882TAB-K450	114,3	130	60	84	30	24	15	STU 218
882TAB-K750	190,5	210	60	84	30	24	15	STU 230
882TAB-K1000	254	270	60	84	30	24	15	STU 240
882TAB-K1200	304,8	320	60	84	30	24	15	STU 248

Material: polyethylene UHMWPE (black) with molecular density 1.000.000.

Standard packaging: the corner tracks are supplied complete with carry and return sections. Straight tracks are supplied as single profile 2 m long.

Special dimensions on application.

When ordering indicate the No. of strands required:

KTU218610 1 S
Code No. of strands

Linear expansion coefficient: 2×10^{-4}

Calculation of thermal expansion see page 98.

Operating temperature:

In air (-40 to +80 °C).

In hot water (+70 °C).

Positioning: see page 101.

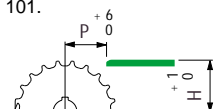

Compact Corner Tracks

for Series 881 M

Magnetic corner tracks

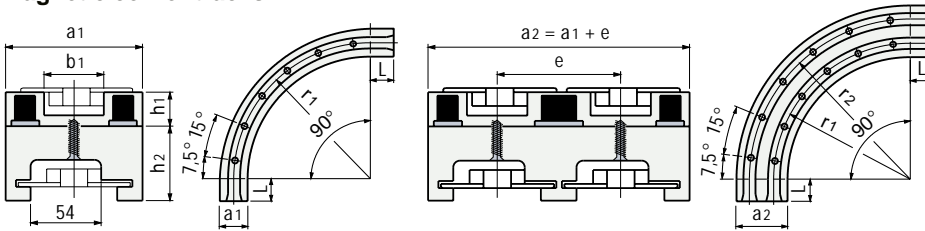

KMU

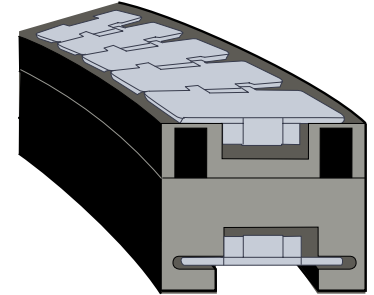

Used for Chain Type	Chain width mm	Radius r1 mm	Width a1 mm	L mm	± 0.5 b1 mm	h1 mm	h2 mm	Pitch e mm	Rexnord Order No.
881M-K325	82,5	500	100	-	44,2	27	55	90	KMU 013 500...*
			100	125	44,2	27	55	89	KMU 013 500...L 125
			111	100	44,2	27	55 (63*)	85	KMU 013 500...L 100
		680	100	100	44,2	27	55	90	KMU 013 680...
		860	100	125	44,2	27	55	90	KMU 013 860...
881M-K330	83,8	500	100	100	44,2	27	63	85	KMU 113 500...
881M-K450	114,3	500	129	125	44,2	27	63	120	KMU 018 500...
		610	129	125	44,2	27	55 (63*)	120	KMU 018 610...
881M-K750	190,5	610	214	125	44,2	27	55	196	KMU 030 610...

* = Supplied without the L straight-line sections.

• = Only for corner tracks of 2 or more strands.

for Series 881 M, 880 MG

Magnetic corner tracks

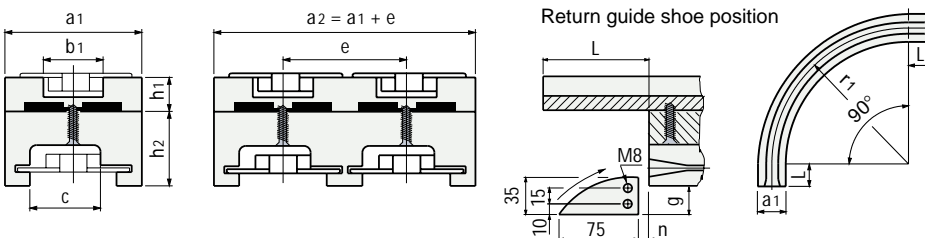

COMBI

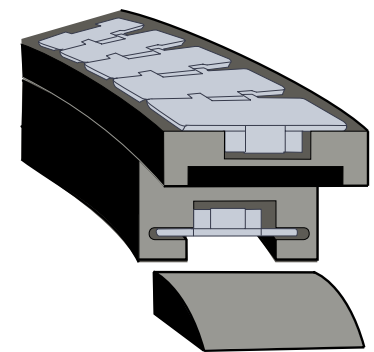

Used for Chain Type	Chain width mm	Radius r1 mm	Width a1 mm	L mm	b1 mm	c mm	h1 mm	h2 mm	Pitch e mm	n mm	g mm	Rexnord Order No.
881 M-K325 880 MG-K325	82,5	500	100	100	44	50	27	55	90	Gap 0	30	COMBI 013 500...
			100	125	44	50	27	55	89	Gap 0	30	COMBI 013 500...L 125
			111	100	44	50	27	63	85	20	20	COMBI 013 500...L 100
		680	100	100	44	50	27	55	90	Gap 0	30	COMBI 013 680...
		860	100	125	44	50	27	55	90	Gap 0	30	COMBI 013 860...
881 M-K330	83,8	500	100	100	44	50	27	63	85	20	20	COMBI 113 500...
881 M-K450	114,3	500	129	125	44	54	27	63	120	20	20	COMBI 018 500...
		610	129	125	44	54	27	63	120	20	20	COMBI 018 610...
881 M-K750	190,5	610	214	125	44	54	27	55	196	20	20	COMBI 030 610...

Magnetic corner tracks allow for easy maintenance and cleaning because the chain can be easily lifted when the conveyor is stopped. On the other hand they keep the chain flat when working.

Material: polyethylene UHMWPE (black) with molecular density 1.000.000.

Standard packaging: the corner tracks are supplied complete with carry and return sections.

When ordering indicate the No. of strands required:

KMU 013500 1
Code No. of strands

Linear expansion coefficient : 2×10^{-4}

Calculation of thermal expansion see page 98.

Operating temperature :

In air (-40 to + 80 °C).

In hot water (+ 70 °C).

Positioning :

see page 101.

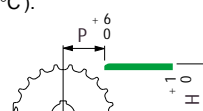

Compact Corner Tracks

for Series FGM 1050, FTM 1050, FTM 1055

COMBI 500

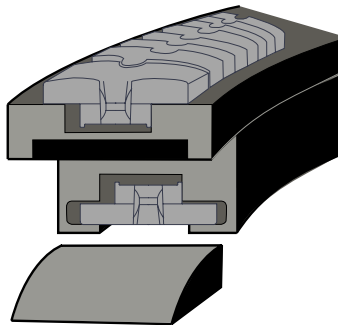

Magnetic corner tracks

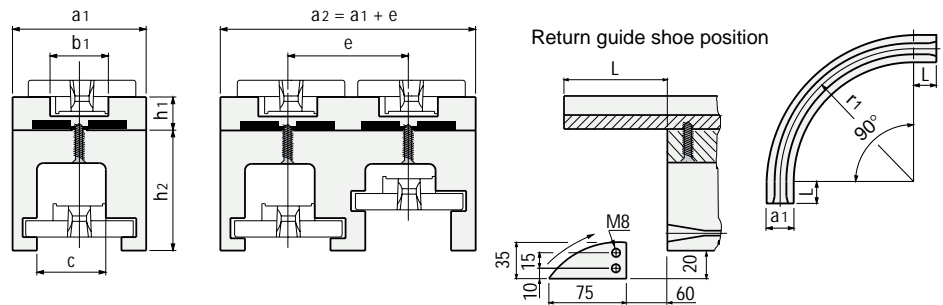

Used for Chain Type	Chain width mm	Radius r1 mm	Width a1 mm	L mm	b1 mm	c mm	h1 mm	h2 mm	Pitch e mm	Rexnord Order No.
FTM 1050-K330 FGM 1050-K330	83,8	500	100	100	44	50	27	63	85	COMBI 513 500...
			111	100	44	50	27	63	85	COMBI 514 500...
		500	100	-	44	50	27	55 (63*)	85	COMBI 513 500...L 0*
			111	100	44	50	27	63	85	COMBI 514 750...
		750	100	100	44	50	27	63	85	COMBI 513 750...
			111	100	44	50	27	63	85	COMBI 514 1000...

* = Supplied without the L straight-line sections and guide shoe. • = Only for corner tracks of 2 or more strands.

COMBI 600

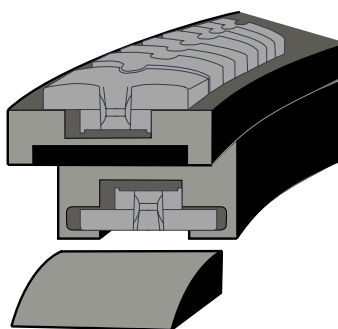

Magnetic corner tracks

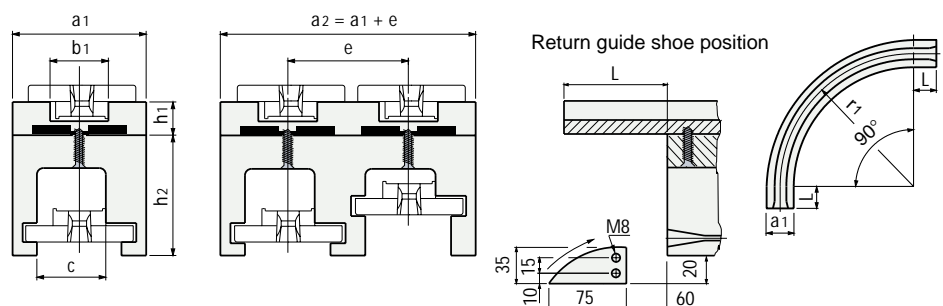

Used for Chain Type	Chain width mm	Radius r1 mm	Width a1 mm	L mm	b1 mm	c mm	h1 mm	h2 mm	Pitch e mm	Rexnord Order No.
FTM 1055-K330	83,8	500	100	100	44	50	27	63	85	COMBI 613 500...
			111	100	44	50	27	63	85	COMBI 614 500...
		500	100	-	44	50	27	55 (63*)	85	COMBI 613 500...L 0*
			111	100	44	50	27	63	85	COMBI 614 750...
		750	100	100	44	50	27	63	85	COMBI 613 750...
			111	100	44	50	27	63	85	COMBI 614 1000...

* = Supplied without the L straight-line sections and guide shoe. • = Only for corner tracks of 2 or more strands.

Magnetic corner tracks allow for easy maintenance and cleaning because the chain can be easily lifted when the conveyor is stopped. On the other hand they keep the chain flat when working.

Material: polyethylene UHMWPE (black) with molecular density 1.000.000.

Standard packaging: the corner tracks are supplied complete with carry and return sections.

When ordering indicate the No. of strands required:

COMBI613500 1
Code No. of strands

Linear expansion coefficient: 2×10^{-4}

Calculation of thermal expansion see page 98.

Operating temperature:

In air (-40 to + 80 °C).

In hot water (+ 70 °C).

Positioning:
see page 101.

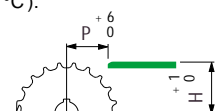

Compact Corner Tracks

for Series 1874 TAB, 1873, 1874 G, 1873 G, 1873 GS, HFP 1873 TAB

Corner tracks

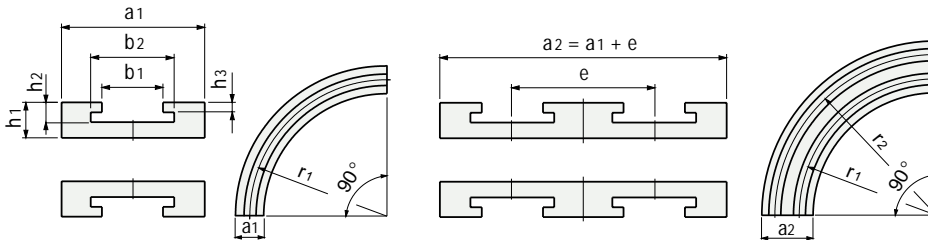

Used for Chain Type	Chain width mm	Radius r1 mm	Width a1 mm	± 0.5 b1 mm	b2 mm	h1 mm	h2 mm	h3 mm	Pitch e mm	Rexnord Order No.
1873-K325 1874-K325	82,5	500	100	34,6	70	36	29	19	90	KTU 313 500...
1873-K450	114,3	500	125	34,6	70	36	29	19	120	KTU 318 500...
1873-K600 1874-K600	152,4	610	160	34,6	70	36	29	19	160	KTU 324 610...
1873-K750 1874-K750	190,5	610	200	34,6	70	36	29	19	195	KTU 330 610...
1873-K1000	254	610	260	34,6	70	36	29	19	260	KTU 340 610...
1873-K1200	304,8	610	310	34,6	70	36	29	19	310	KTU 348 610...

KTU 300

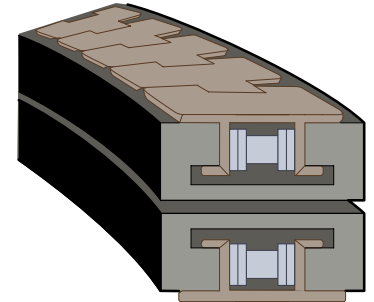

Straight tracks

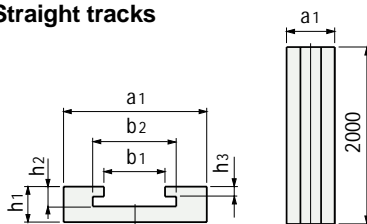

Used for Chain Type	Chain width mm	Width a1 mm	b1 mm	b2 mm	h1 mm	h2 mm	h3 mm	Rexnord Order No.
1873-K325 1874-K325	82,5	100	34,6	70	36	29	19	STU 313
1873-K450 1874-K450	114,3	125	34,6	70	36	29	19	STU 318
1873-K600 1874-K600	152,4	160	34,6	70	36	29	19	STU 324
1873-K750 1874-K750	190,5	200	34,6	70	36	29	19	STU 330
1873-K1000	254	260	34,6	70	36	29	19	STU 340
1873-K1200	304,8	310	34,6	70	36	29	19	STU 348

STU 300

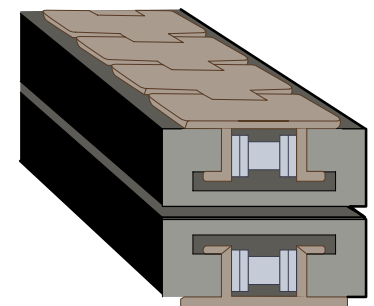

Material: polyethylene UHMWPE (black) with molecular density 1.000.000.

Standard packaging: the corner tracks are supplied complete with carry and return sections. Straight tracks are supplied as single profile 2 m long.

Special dimensions on application.

When ordering indicate the No. of strands required:

KSU 313 500 1
Code No. of strands

Linear expansion coefficient: 2×10^{-4}
Calculation of thermal expansion see page 98.

Operating temperature:
In air (-40 to +80 °C).
In hot water (+70 °C).

Positioning: see page 101.

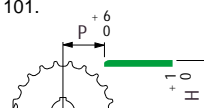

Compact Corner Tracks

for Series SLBP 882 TAB, LBP 883

KTU 200

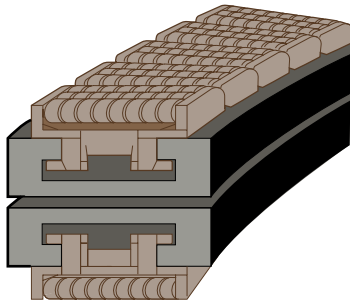

Corner tracks

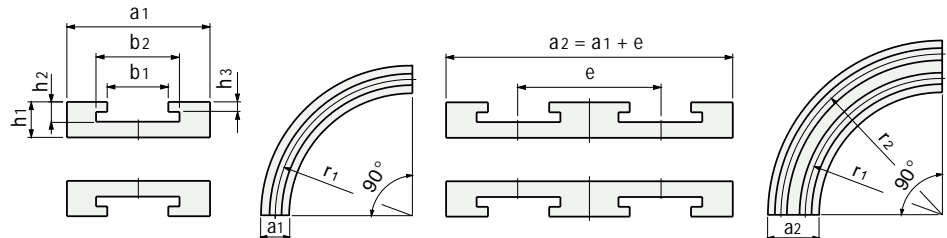

Used for Chain Type	Chain width mm	Radius r1 mm	Width a1 mm	b1 mm	b2 mm	h1 mm	h2 mm	h3 mm	Pitch e mm	Renord Order No.
SLBP882TAB-K375	95,2	700	110	60	84	30	24	15	*	KTU215700...S
LBP883TAB-K450	114,3	610	130	60	84	30	24	15	*	KTU218610...S
LBP883TAB-K750 SLBP882TAB-K750	190,5	610	210	60	84	30	24	15	*	KTU230610...S

* = To be specified upon order.

STU 200

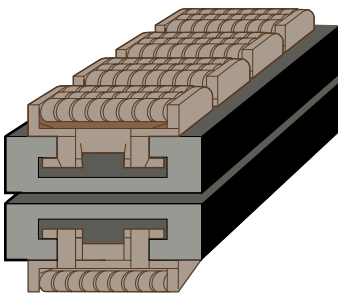

Straight tracks

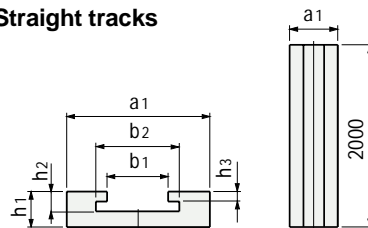

Used for Chain Type	Chain width mm	Width a1 mm	b1 mm	b2 mm	h1 mm	h2 mm	h3 mm	Renord Order No.
SLBP882TAB-K375	95,2	110	60	84	30	24	15	STU 215
LBP883TAB-K450	114,3	130	60	84	30	24	15	STU 218
LBP883TAB-K750 SLBP882TAB-K750	190,5	210	60	84	30	24	15	STU 230

Material: polyethylene UHMWPE (black) with molecular density 1.000.000.

Standard packaging: the corner tracks are supplied complete with carry and return sections. Straight tracks are supplied as single profile 2 m long.

Special dimensions on application.

When ordering indicate the No. of strands required:

KTU215700 1 S
Code No. of strands

Linear expansion coefficient: 2×10^{-4}
Calculation of thermal expansion see page 98.

Operating temperature :

In air (-40 to +80 °C).
In hot water (+70 °C).

Positioning : see page 101.

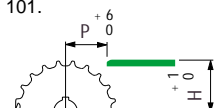

Compact Corner Tracks

for Series 1700 TABK, 1790 TABK, 1710 TABK, 1713 TABK

Corner tracks

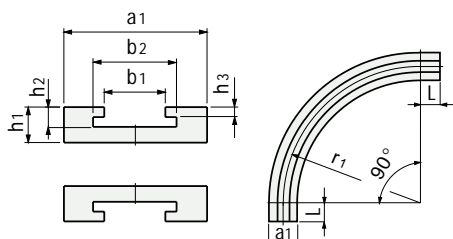

Used for Chain Type	Chain width mm	Radius r1 mm	Width a1 mm	b1 mm	b2 mm	h1 mm	h2 mm	h3 mm	L mm	Renord Order No.
1700TABK	55	250	100	58	70	40	21	12	50	KTU508250S
1790TABK		500	100	58	70	40	21	12	50	KTU508500S
1710TABK	98	250	110	58	70	40	31	22	50	KTU515250S
		500	110	58	70	40	31	22	50	KTU515500S
1713TABK	253	500	270	58	70	40	30,5	20	50	KTU540500S

KTU 500

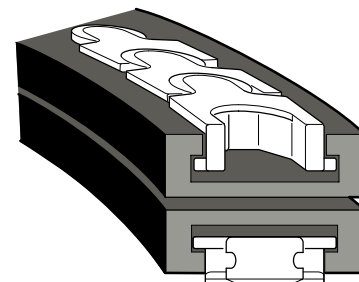

Straight tracks

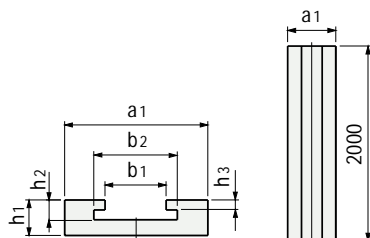

Used for Chain Type	Chain width mm	Width a1 mm	b1 mm	b2 mm	h1 mm	h2 mm	h3 mm	Renord Order No.
1700TABK	55	100	58	70	40	21	12	STU508
1790TABK		100	58	70	40	21	12	STU508
1710TABK	98	110	58	70	40	31	22	STU515
1713TABK	253	270	58	70	40	30	20	STU540

STU 500

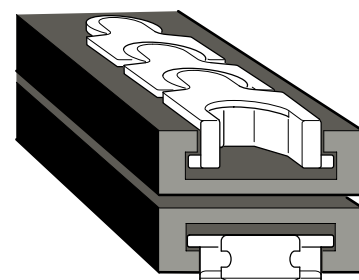

Material: polyethylene UHMWPE (black) with molecular density 1.000.000.

Standard packaging: the corner tracks are supplied complete with carry and return sections. Straight tracks are supplied as single profile 2 m long.

Special dimensions on application.

Linear expansion coefficient: 2×10^{-4}
Calculation of thermal expansion see page 98.

Operating temperature:
In air (-40 to +80 °C).
In hot water (+70 °C).

Positioning: see page 101.

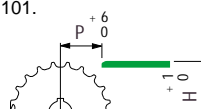

Engineering Manual

Conveyor Design

Straight Running and Sideflexing Chains

Wear Strips

Wear strips are used for one or several of the following reasons:

- protection of the chain carrying way and chain from excessive wear;
- reduction of friction thus reduction in drive power;
- reduction in plate wear.

There are many materials which are suitable for use as wear strips. However, none of these are equally suitable for all types of chains. In determining the effectiveness of the wear strips, i.e., whether the surroundings are dusty or clean, corrosive or hot, or whether lubrication takes place or not, the operating conditions are also important. Wear strips must be specially selected for each individual application, and all relevant factors taken into account.

Plastic wear strips vary widely in their efficiency. Due to their differing characteristics, the intended application should be carefully considered.

Plastic wear strips should be secured at short length and only at one end. This allows them to expand when subjected to the effects of heat or moisture.

Selection of correct wear strip material

Once the correct chain has been selected for a particular application, it will wear out before it breaks in fatigue. With straight running conveyors, wear normally occurs on the upper and lower sides and in the hinges. The chain is normally regarded as being worn when the plate tops have been reduced to approximately half of their original thickness, or when the smooth transportation of the products is impaired. It is also regarded as being worn when its elongation amounts to more than 3% what makes the chain jump the sprocket.

The correct combination of chain and wear strip ensures maximum service life.

Thus, friction and wear resistance are the two most important factors in selecting the material for the wear strip.

1) The lower the coefficient of friction between chain and wear strip, the longer the service life of the chain.

2) The higher the resistance to wear in chain and wear strip, the longer the service life of both.

In the long term, the factors of chain tension, peak load, lubrication conditions, abrasion and transport speed determine the actual degree of wear in any given combination of chain and wear strip. High speeds and dry running conditions are the factors which produce the severest wear.

Metal wear strips

Metal wear strips have a greater coefficient of friction than those of plastic material but offer higher hardness.

They are, therefore, suited for abrasive applications. Abrasive particles are less likely to embed.

STEEL

Cold rolled carbon steel is recommended. The surface roughness should be between 1.6 μm and 3.2 μm . Use hardened or cold formed steel with 25-30HRc. The lubricants should contain an anti-rust agent.

STAINLESS STEEL

Here, too, a cold rolled steel with a roughness of 3.2 μm is recommended. Austenitic steels have the best resistance to corrosion. When plastic chains are in use, the wear strips should have at least 25 HRc. With softer wear strips, the two different materials (steel and plastic) may influence one another and cause the formation of wear debris which is black in colour (similar to graphite). This wear should also be taken into account in transporting products which require a high degree of cleanliness.

Martensitic steel has the same hardness and virtually the same resistance to wear as austenitic steel. Its resistance to corrosion is however not so high.

ALUMINIUM

Due to its low resistance to wear, aluminium should not be used.

Plastic wear strips

Plastic wear strips have a lower coefficient of friction than metal wear strips. As a rule, they are easily installed and the noise level is lower.

The following materials can be used:

ACETAL

As contact between two identical materials should be avoided, not to be recommended in combination with acetal chains.

NYLATRON

Nylatron (polyamide with molybdenum di-sulphide) is the best wear strip material for dry applications because of its low wear rate and low friction.

Note

Nylatron absorbs moisture and expands. For this reason, room for expansion must be provided and fasteners must allow for movement.

MARBETT RAM-EXTRUDED UHMWPE

This ultra high molecular weight polyethylene is recommended for dry and lubricated operating conditions.

UHMWPE has a wear rate under dry conditions which is similar to that of Nylatron. It is, however, chemically stable and is unaffected by moisture. It is not recommended for dry operation on corners where the chain load or speed are high.

Compared to standard extruded HMWPE the tendency to embed abrasive particles is reduced, so the wear on chain is much lower.

Abrasive operating conditions

Abrasive materials include broken glass, metal chips, sand etc. which may cause excessive wear to chains and wear strips.

As the abrasive substance may become lodged in the soft plastic and damage the chain, plastic wear strips should not be used under such conditions.

Metal wear strips should be used here.

Conveyor Design

Straight Running and Sidflexing Chains

Carrying way

In figure 1, types A,B and C illustrate possible arrangements for carrying ways and wear strips. The wear strips are attached to the surface of the carrying way.

They should be slightly wider than the underside of the chain plates.

Types A and B show different possibilities for single-strand conveyors.

Type C illustrates the separation of two parallel chains running either in the same or opposite directions.

In order to prevent contact and subsequent damage, a narrow edge separates the chains.

Unless extremely accurate chains guidance is required, chains running in the same direction at the same speed do not require separation.

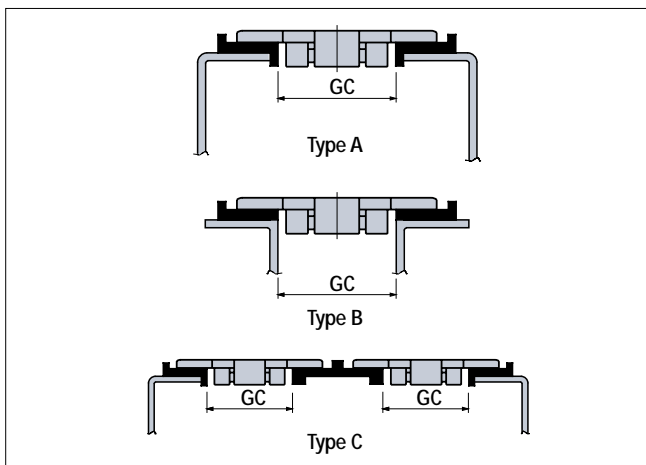

Fig. 1 - Arrangements of chain carrying way and wear strip

Table 1 below gives the recommended clearance (GC) between chains and wear strips.

Chain No.	Guide clearance (GC)
512	44,5
802 - 805	82
812 - 815	44
SSR 812 K125/175	23,5
866	41,3
1864	34,9
820 - 831	44,5
821	140
843 - 845	23,8
963	36,5

Table 1 - guide clearance (GC) for straight running chains

Calculation of thermal expansion

$$L_t = L_0 \cdot [1 + a \cdot (T - 20^\circ\text{C})]$$

L_t = final length (mm.)

L_0 = initial length (mm.)

a = coefficient of linear expansion.

T = operating temperature ($^\circ\text{C}$).

20°C = ambient temperature.

Example :

a guide having initial length $L_0 = 1000$ mm, coefficient of linear expansion 2×10^{-4} , and an operating temperature of 70°C , expands by :

$$L_t = 1000 \text{ mm} \cdot [1 + 0,0002 \cdot (70^\circ\text{C} - 20^\circ\text{C})] = 1010 \text{ mm}$$

Wearstrips transfers

On straight sections with a length of more than 3 metres, or for high ($40^\circ - 70^\circ\text{C}$) application temperatures, we recommend to divide the wearstrip into several sections, because of the thermal expansion of the strips. The size of clearance is depending on the expected elongation due to e.g. thermal expansion, see drawing.

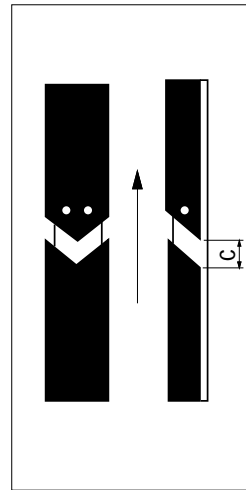

Clearance C depends on wearstrip length and environmental temperatures. Example :

For MARBETT UHMWPE material the coefficient of expansion is :

$0.2 \text{ mm/m}^\circ\text{C}$

A temperature increase of 40°C would elongate a 2 meter wearstrip with :

$$40^\circ\text{C} \cdot 2 \text{ mtr.} \cdot 0.2 = 16 \text{ mm}$$

In this case, the gap between the wearstrips should be a bit larger than 16 mm, e.g. 17 mm.

Note

It is recommended to cut the wearstrips at double 45° . This provides for smooth chain transfers.

When mounting the wearstrips, make sure only the infeed side of the wearstrip is fixed to the conveyor frame to avoid bulging of the wearstrips.

Chamfering of wearstrips

Wearstrips should always be chamfered at the beginning of the strip (where strips are fixed). Chamfering of wearstrips reduces the risk of chain-obstruction. This way, the chain or belt is smoothly guided through the conveyor.

The wearstrips should be chamfered at the sides and at the top.

In the drawing is shown what a proper chamfered wearstrip should look like.

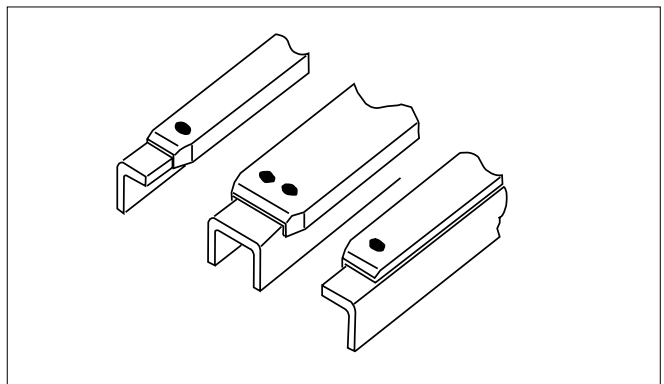

Fig. 2 - Chamfering of wearstrips

Note

Other information and ideas on conveyor design can be found on MARBETT CONVEYOR COMPONENTS catalogue

Conveyor Design

Straight Running and Sideflexing Chains

Straight running

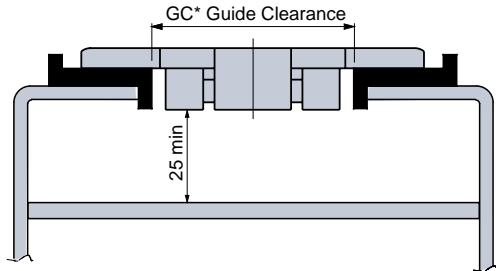

Magnetic sideflexing

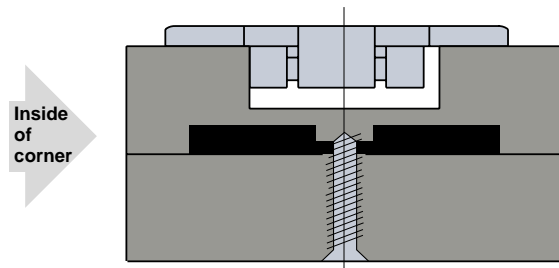

Sideflexing (Bevel design)

Straight running

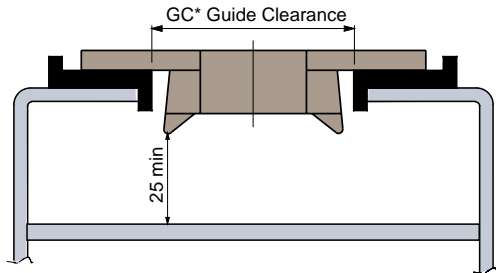

Corner section

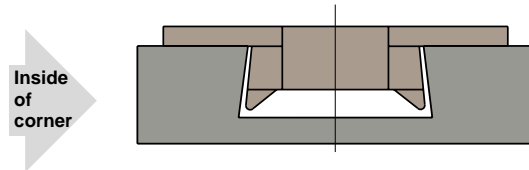

Sideflexing (TAB design)

Straight running

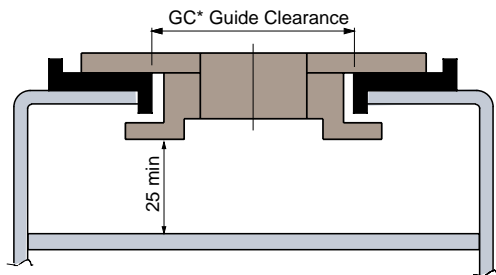

Corner section

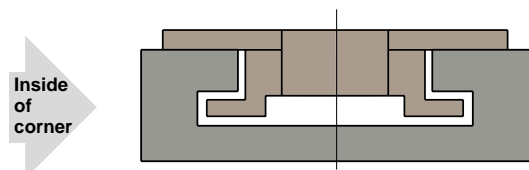

Multiple strand chains

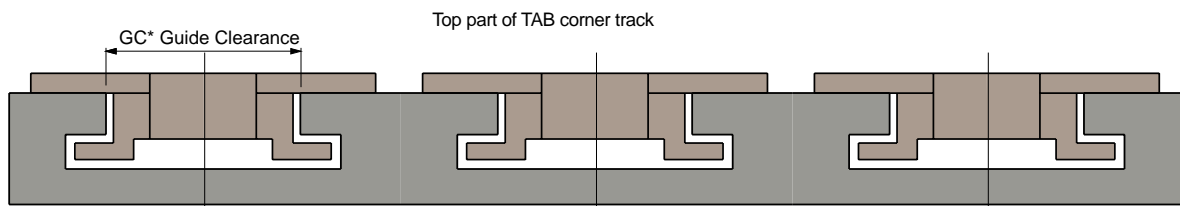

*) the guide clearances (GC) are shown on page 98 and on chain data in the catalogue

Conveyor Design

Straight Running and Sidflexing Chains

Different returnpart constructions

There are several ways to guide a chain or a belt in the returnpart of a conveyor. The most common ways are by means of return rollers, wearstrips or return guide shoes. Below a comparison is given for different systems.

Return Way "serpentine style"

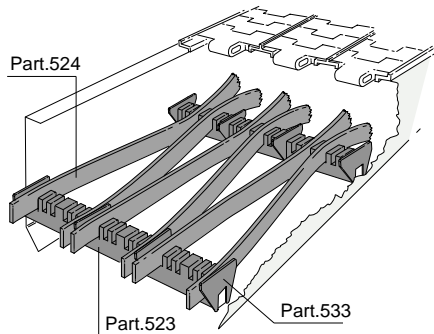

- + Full support of the chain over the length of the conveyor.
- + Reduced noise in returnpart.
- More complex construction and less favourable accessibility for maintenance.
- Less possibility to absorb chain elongation.
- Uneven wear of the chain when not supported over entire width
- Higher friction.

Material used for wearstrips should be UHMWPE

Guideshoes return Way

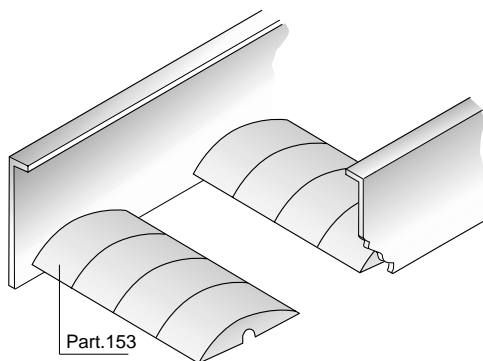

- + Good accessibility of the conveyor returnpart.
- + Simple construction.
- + Debris that falls upon the chain in the returnpart of the conveyor is ejected by the movement of the chain.
- + Suitable for LBP chains.
- Risk of uneven wear of the chain surface when abrasive particles are embedded in the plastic guideshoes.
- High friction.

Minimum guide shoe radius is 200 mm

Roller return Way

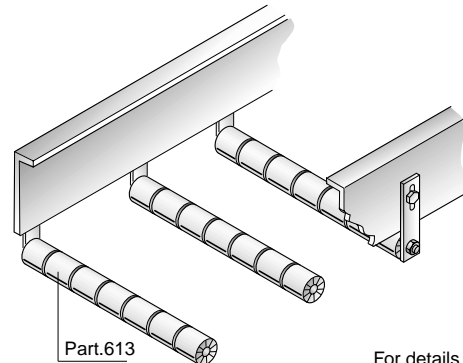

For details, see page 102

- + Reduced wear of the chain surface due to the reduction in speed difference and the reduced friction.
- + Simple construction and good accessibility of returnpart.
- + Debris that falls upon the chain in the returnpart of the conveyor is ejected by the movement of the chain.
- Only point contact between chain and roller.

Rollers must be able to rotate freely at all times. Small roller may cause a rattling sound

Corners bevel design

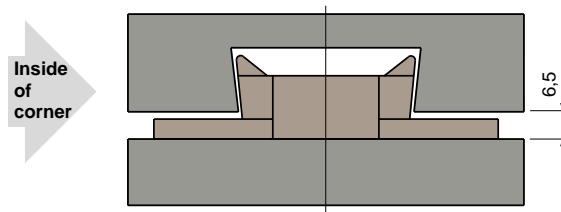

Corners TAB design

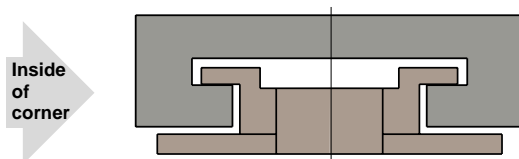

Corners Magnetic Design

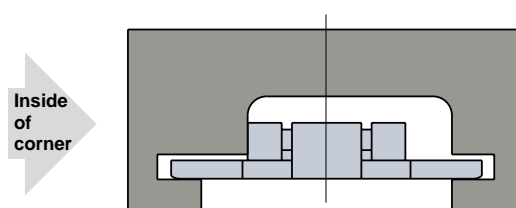

Conveyor Design

Straight Running and Sideflexing Chains

Sprockets

When the chain enters the sprocket, it tends to raise and fall slightly. For this reason, the sprocket should be mounted in such a way that its highest point is no higher than the top of the wear strips. The front edges of the wear strips should be bevelled to allow smooth and free running of the chain. Figure 3 and the following formula and dimensions are intended as a recommendation for aligning the sprocket with the top of the wear strip.

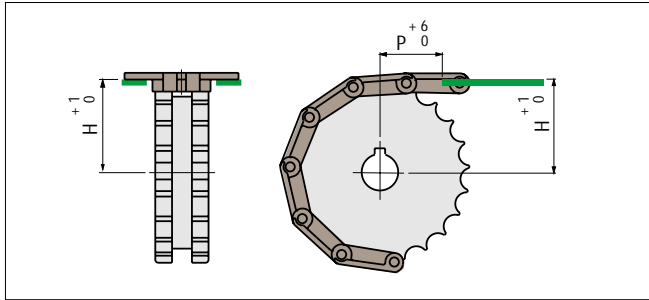

Fig. 3- Alignment of the sprocket

Sprockets for chains 1873, 2873 and 3873:

The minimum number of teeth for chains, 1873 and 3873, is 15 and for chains, 2873, 24 teeth. If the number of teeth is less than this minimum, the distance between the hub of the sprocket and the hold-down tabs is insufficient (see figure 4)

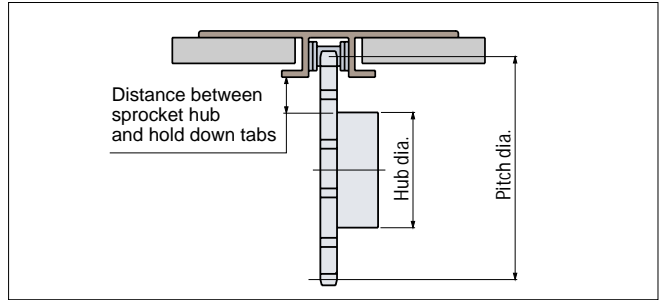

Fig. 4- Minimum number of teeth for TableTop Chains

Chain No.	H - mm	P - mm
FGM 1050 - FTM 1050	(Dp:2) + 3,5	26
FTM 1055	(Dp:2) + 3,4	26
512 - 802 - 805 - 812 - 815 - 820 - 821 - 881 - 881 M - 8811 - 8811 TAB - SLBP 821	(Dp:2) + 3,2	40
831 - XLBP 831	(Dp:2) + 2,4	40
880 - 880 TAB - 880 BO	(Dp:2) + 3,6	40
879 - 879 TAB - 879 BO - LBP 879 BO	(Dp:2) + 2,8	40
882 - 882 TAB - SLBP 882 TAB - LBP 883	(Dp:2) + 4,8	40
866 - 963 - 1864 - 1873 - 1874 - 2873 - 3873	(Dp:2) + 11	40
1108	(Dp:2) - 6,5	26
1700K - 1700TABK - AC1700K - 1701 - 1790K - 1790TABK - 1702 - 1716K - 1765 ZeroGap™	(Dp:2) - 12	50
1710K - 1710TABK	(Dp:2) + 18	50
1713K - 1713TABK	(Dp:2) + 16	50

Table 2- dimensions H and P

Dp = primitive diameter of drive sprocket - mm.

Keyway dimensions

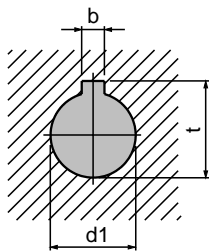

d1 mm	b mm		t mm		
	nom.	toll.	nom.	toll.	
25	8	+ 0,036 0	28,3	+ 0,2 0	
30	8		33,3		
35	10		38,3		
40	12	+ 0,043 0	43,3		
45	14		48,8		
50	14		53,8		
60	18		64,4		

Table 3- Keyway dimensions for metric shaft diameters (UNI 6604 - 69 / ISO 773)

d1 inch	b inch		t inch	
	min	max	min	max
1 "	0,250	0,252	1,114	1,124
1 1/4 "	0,250	0,252	1,367	1,377
1 1/2 "	0,375	0,377	1,669	1,679
1 3/4 "	0,375	0,377	1,922	1,932
2 "	0,500	0,502	2,223	2,233

Table 4- Keyway dimensions for imperial shaft diameters (USA standard)

Idler wheels

Rexnord idler wheels can be used in all straight running conveyors. They are made of high quality plastic material, selflubricating and resistant to most chemical solution and corrosive agents. Installation of most idler wheels in existing conveyors can be carried out without difficulty. Place the idler wheel on a bright drawn stainless steel shaft and attach one set collar to the right and left of the wheel (see figure 5)

Smoothest running is achieved when the idler wheel is installed slightly lower than the top of the wear strip. For sideflexing chains, sprockets should also be used on the idler side. In new conveyors, Rexnord idler wheels should be used throughout the system. Ensure that the correct clearances are observed as shown in figure 5.

As the idler wheels run on a shaft, bearings are not necessary.

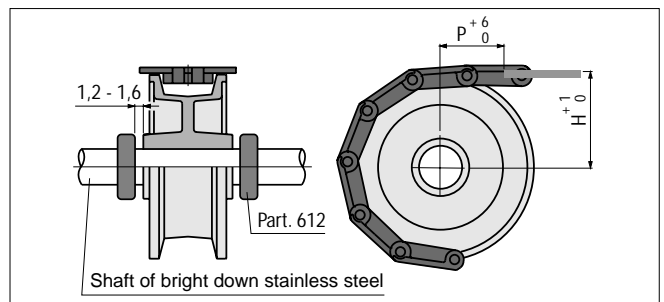

Fig. 5- Installation and alignment of idler wheel

Conveyor Design

Straight Running and Sidflexing Chains

Catenary sag and return way

It is recommended to position the drive at the end of all Rexnord chains and to ensure that the carrying and return strands are well guided.

- If the specified catenary sag is observed, the working load of the chain will be sufficient to ensure that it does not jump out of the sprockets.
- The chain is pulled and not pushed.
- Wear in the chain hinges is reduced, as the return strand adds little or no load. Movement in the hinges is reduced when a smooth return of the chain takes place.
- Greater distances between conveyor centres are possible.

Figure 6 shows a typical conveyor. After the drive sprocket, there is a gap for the catenary sag. The entry radius in the return allows the chain to feed onto it smoothly. During operation, the catenary sag should be between 75 and 125 mm. Should it exceed this figure, one or more links have to be removed.

On conveyors with no catenary sag there is a great deal of wear on the link hinges, and they are subjected to increased loading, which has to be adsorbed either in the bearings or in the chain itself. Excessive sag at the drive sprocket reduces both the angle of wrap and the ability to transfer force. This also causes the chain to pulsate.

Note

The infeed radius should be greater than the backflex radius. In order to ensure good running conditions, the angle of wrap should be no less than 150°

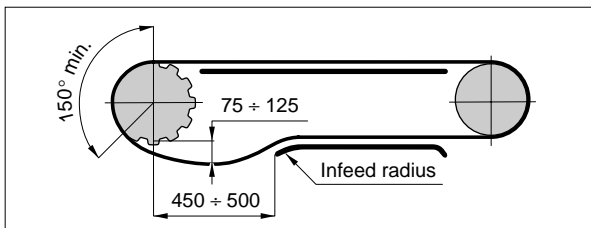

Fig. 6- A Typical conveyor

Roller returns

As shown in figure 7, the chain can also return over rollers or guide shoes instead of wear strips. In order to ensure the required catenary sag, it is important that the first roller or guide shoe is at a sufficient distance from the head drive sprocket. Distance A must be greater than distance B between the rollers. At slow speeds and low loads, rollers should be selected when ease of cleaning is more important than the service life of the chain. The diameter of roller should be at least twice that of the smallest backflex radius of the chain (see Tables 5 and 6). This is an important factor in reducing the noise level. In order to limit the backflexing of chains, if smaller rollers are used for reasons of space, the catenary sag must be reduced. Due to the large backflex radius, roller and guide shoe return are not recommended for TableTop chains of type 845, 1873, 1874, 2873 and 3873.

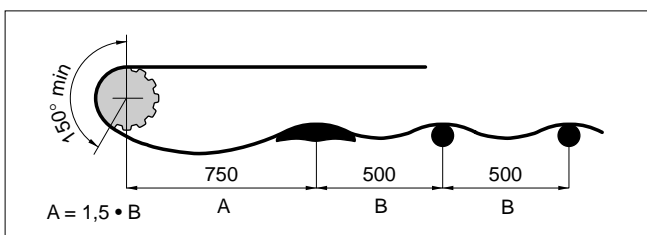

Fig. 7- Roller return

Chain No.	Minimum backflex radius
512	100
802 - 805	150
SS 812 - SSR 812 - SSX 812	75
SSC 812	150
S 815 - SS 815	150
866	318
1864	305
820 - 821 - 831	40
843 - 963	153
845	458

Table 5- Minimum backflex radius for straight running chains

Chain No.	Minimum backflex radius
881 - 8811 - 8811 TAB	100
881 M	100
1874	254
4874	305
879 - 879 TAB - 880 - 880 TAB	40
879 BO	40
FGM 1050 - FTM 1050 - FTM 1055	130
880 MG	50
882 - 882 TAB	40
RR 882	76
LPC 279	70
1843	102
1873	305
2873	1000
3873	178

Table 6- Minimum backflex radius for sidflexing chains

Guide returns

For TAB chains which return on their own TAB guides (see figure 8), a guide with a radius greater than the smallest backflex radius is recommended.

At the entry of the return wear, rounded corners should be provided to prevent the chain from catching.

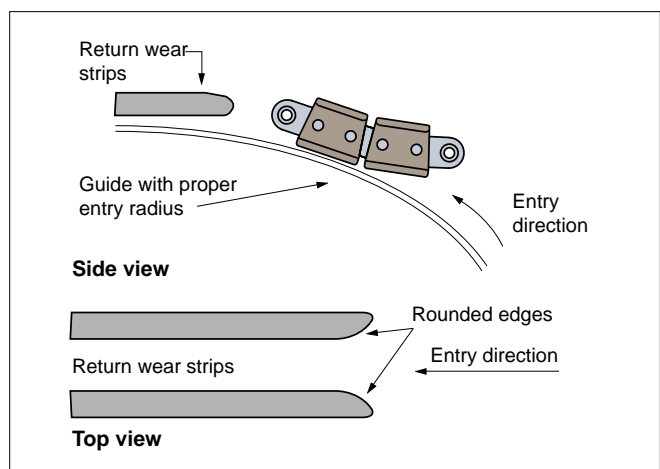

Fig. 8- Return way for sidflexing chains with TAB Guide

Conveyor Design

Straight Running and Sideflexing Chains

Intermediate drive arrangement

An intermediate drive allows the continuous operation of a chain strand over a longer distance than would be possible with only one drive. Each intermediate drive moves the same chain strand onwards to the next drive.

Four different arrangements are possible:

- 1) **Tangential drive**
- 2) **Offset wrap drive**
- 3) **Continuation drive**
- 4) **Carousel with tangential sprockets**

Tangential drive

A drive sprocket engages the straight running chain in the same way as a rack and pinion. This approach is relatively simple, but has several drawbacks. Firstly, in order to ensure that the chain does not "bunch up" after leaving the sprocket, the entire conveyor system has to run tightly. Secondly, under peak loads, the chain tends to jump out of the sprocket. This approach is therefore not to be recommended.

Offset drive

Contrary to tangential drive, this arrangement is limited to sideflexing chains. Figures 9 and 10 show two possible variations of this approach. Basically, the chain tension which is not absorbed by the drive sprocket (as well as excess chain) is compensated for by a catenary sag. The chain then engages an idler sprocket or wheel and continues to run as a load strand.

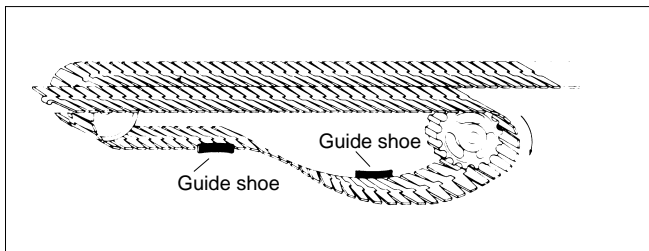

Fig. 9- Offset drive arrangement with side transfer.

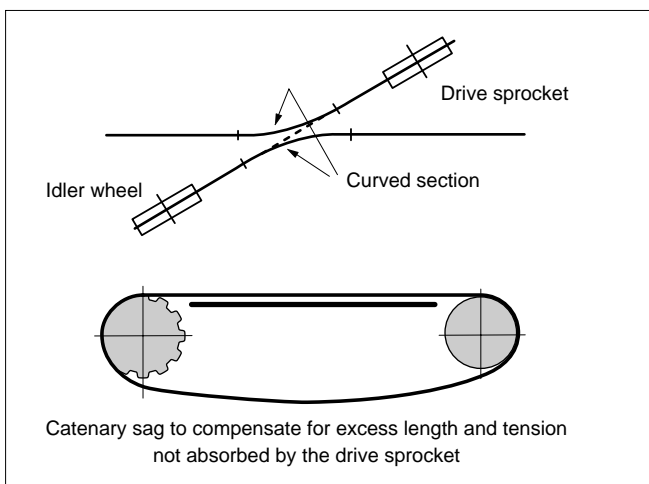

Fig. 10- Offset drive arrangement with inline transfer.

Continuation drive

On the top view this is a straight design, but it requires a transfer plate.

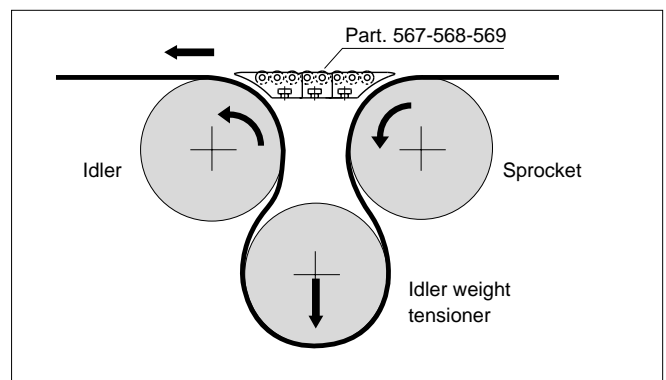

Fig. 11- Continuation drive

Carousel with tangential sprockets

Only with 880 BO, 879 BO and 1080 chains.

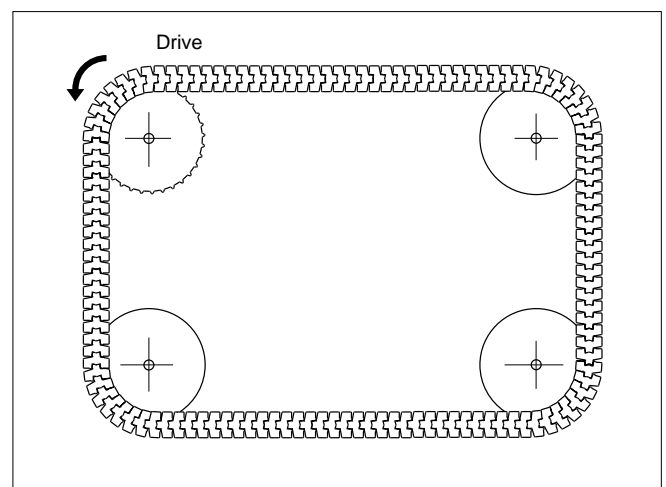

Fig. 12- Carousel with tangential sprockets

Conveyor Design

Straight Running and Sidflexing Chains

Transfers

The smooth transfer from one chain to another is essential for the protection of the product and prevention of down-time. These transfers are carried out by means of turntables and deadplates.

Side transfers

The side transfers are the most popular and economical way of transferring the product from one chain to another. Good design and accurate alignment of the chain and the guide rail are of critical importance. Although this is a relatively simple way of transferring products, it should be ensured that both chains are running at the same height, or that the outfeed chain is slightly lower. The arrangement of the guide rails should be such that the product is conveyed smoothly and at constant speed (see figure 13).

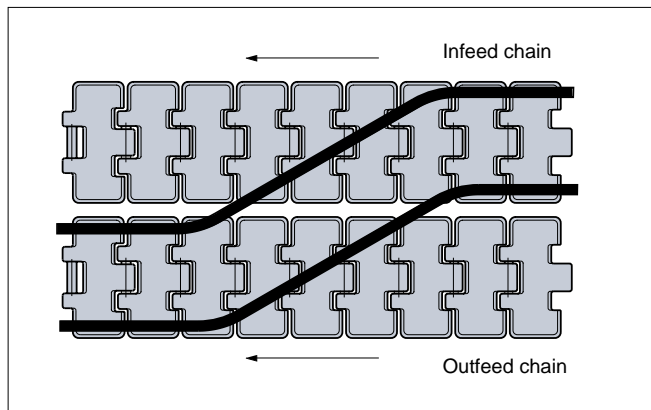

Fig. 13- Side transfer.

Deadplate transfers

Figure 14 shows a deadplate transfer. The deadplate should always be mounted 1 mm lower than the infeed and 1 mm higher than the outfeed chain. The deadplate should be bevelled at the edge. Flexible deadplates can "float" with the chordal action of the chain on the sprocket without producing excessive wear. Deadplate can cause faults when they are mounted too low. There is then a danger of the chain running against the deadplate, thereby causing damage or wear. Deadplates should therefore be adjusted with extreme care.

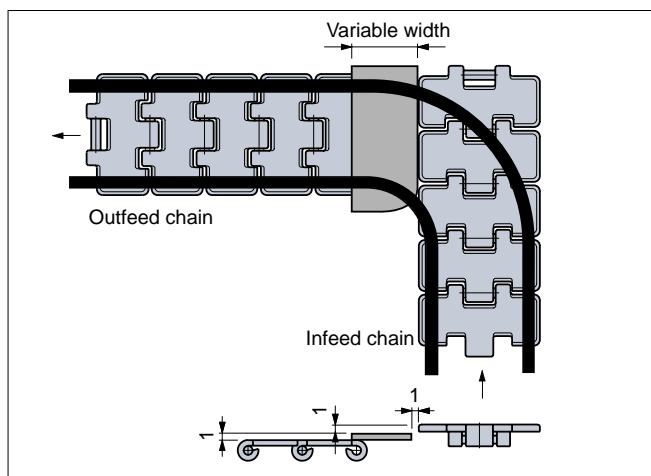

Fig. 14- Transfer using deadplate.

Note

For Dynamic Transfer System™ please refer to our MatTop® catalogue.

Turntable transfer

Turntables should be installed in accordance with the same principles as deadplates. Smooth transfer of the products is only possible if chain and turntable are in exact alignment with one another. The transfer can be improved by bevelling the outer edge of the turntable (see figure 15). The turntable should be slightly lower than the infeed and slightly higher than the outfeed chain. In each case, the difference in height in each case should be approximately 1 mm.

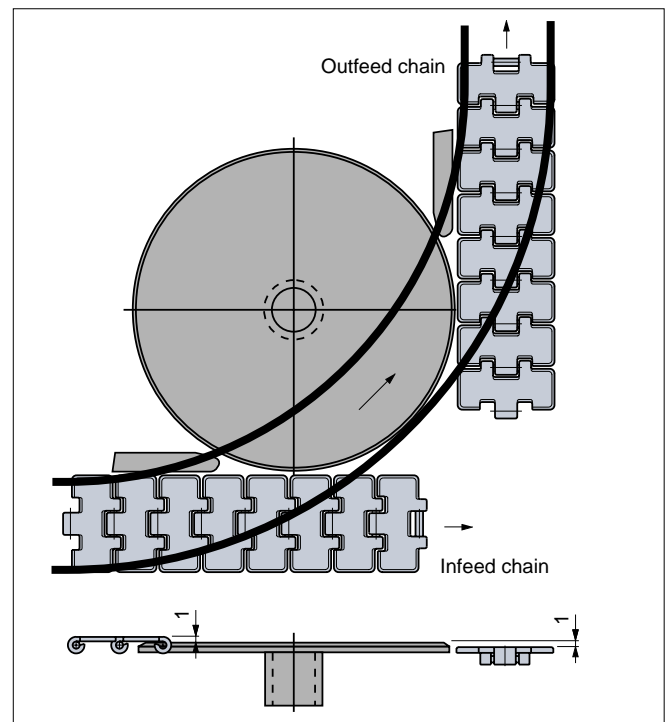

Fig. 15- Transfer using turntable.

Head to tail transfer

Marbett modular transfer roller plates are recommended with big and stable products. For other products flat dead plates are suggested.

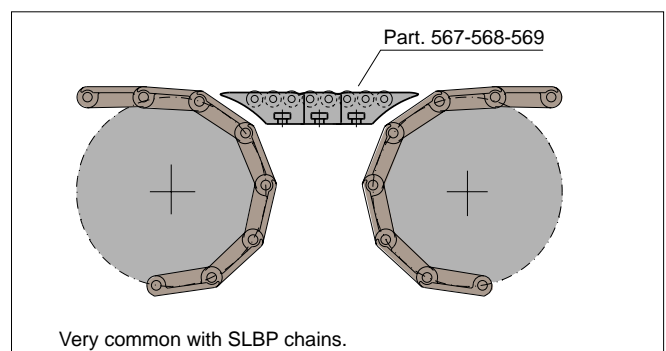

Fig. 16- Head to tail Transfer.

Conveyor Design

Multiflex Chains

Straight run

Figure 17 shows a typical straight running section of a conveyor. Note that the frame is designed to support the chain on the underside of the link. In order to distribute wear evenly over the entire underside of the link, the distance between the wear strips varies. This open design is preferred over full width support since it prevents the built-up of debris in the track. Steel wear strips are used for dry abrasive applications, and stainless steel for wear strips in moist abrasive conditions. In non-abrasive conditions, UHMWPE wear strips should be used. The chain is fully supported at all points on the conveyor. It is held in place by two side members as shown in Section A-A of figure 18. Chain guides are of such a height that they would not interfere with a product that may overhang the sides of the chain. Given proper design and mounting of rails (not shown in section A-A), very wide products can be transported using this chain.

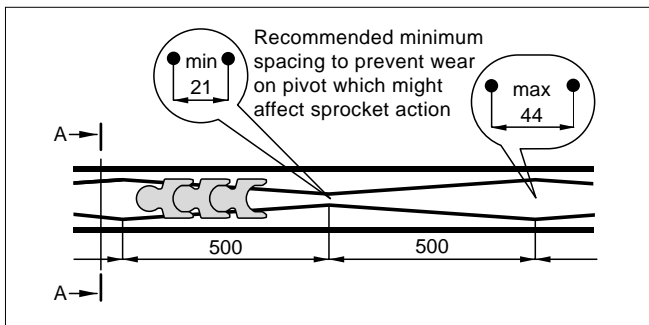

Fig. 17- Typical straight run conveyor (top view).

Corner sections

The corner discs guide the chain around corners. They are used in order to guide the chain without any significant increase in its tension. For corners of 15° or less, a conventional stationary curve (wear strip) can be used. For chains 1701 and 1701TAB, stationary corner wear strips can be used for all radii ($R_{min} = 140$). The corner discs are mounted in such a way that they engage the chain while it is still supported by wear strip (see figure 19). The chain guides are mounted on the outside of the curve, whereas the corner disc provides guidance on the inside of the curve.

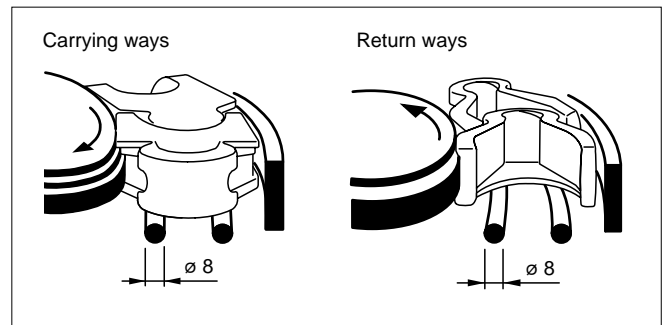

Fig. 19- Typical corner section with chains Series 1700 K - 1700 TAB K - AC 1700 K - 1710 K - 1710 TAB K - 1765 ZeroGap™.

Note

Chain runs at the same height as the disc. This is essential to keep the chain on the disc.

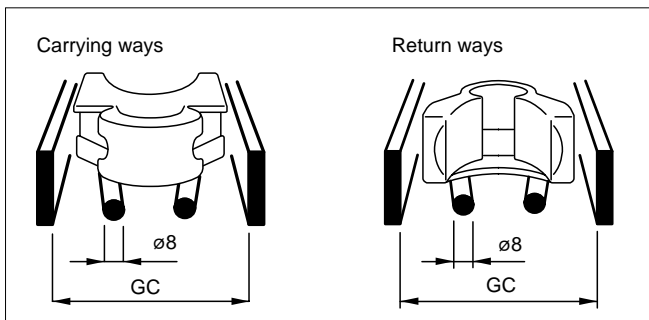

Fig. 18- Section A-A.

Table 7 below gives the recommended clearance (GC) between chains and wear strips.

Chain No.	Guide clearance (GC)
1700 K - 1700 TAB K -1765 ZeroGap™	58
1790 K - 1790 TAB K	58
1720 K - AC 1700 K	58
1716 K - 1702	59,5
1710 K - 1710 TAB K	58
1713 K - 1713 TAB K	58
1755	30,5

Table 7- Guide clearance (GC) for multiflex chains

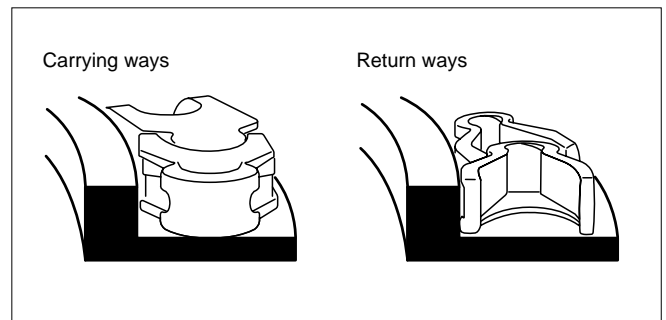

Fig. 20- Typical corner section with chain.

Note

The figures in this section show chain 1700. Most of the data applies equally to the other Multiflex chains.

Conveyor Design

Multiflex Chains

Chain return

A great variety of chain returns are possible with Rex Multiflex chains. This variety of returns offers considerable conveyor design freedom. The best type of return in any given case depends on the design of the chain and other factors (product flow, available space etc.).

Conventional conveyors

If the chain runs at one level, a conventional return can be provided (see figure 21).

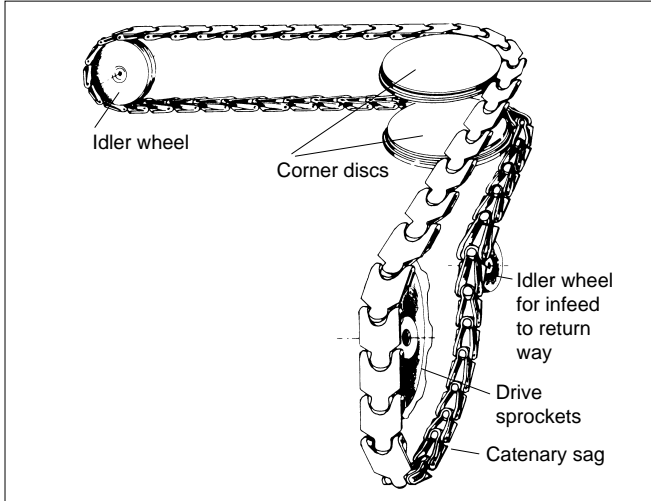

Fig. 21- Conventional return.

Note

In the return section, the corner disc is mounted in the same way as on the load side. It is not mounted upside down.* The upper edge of the disc must be aligned with the lower edge of the returning chain.

Note

Idler wheels are recommended for corner section, not sprockets. In order to hold the chain on the wheel, if the idler wheel has no flange to hold the chain in position, a guide system should be provided in the frame.

*) 1701 is an exception. The return disc is mounted upside down. This applies to bevel style chains only.

Elevating conveyors

Rex Multiflex chains have the ability to elevate or lower products in a very compact area. This figure shows a typical elevating system and how the chain is being returned on such a unit.

Note that the chain hangs straight down from the drive sprocket and side flexes back up into the tail section (there is no sliding return). Elevators can also be designed with combined free-hanging (catenary sag) returns and sliding returns (see figure 22).

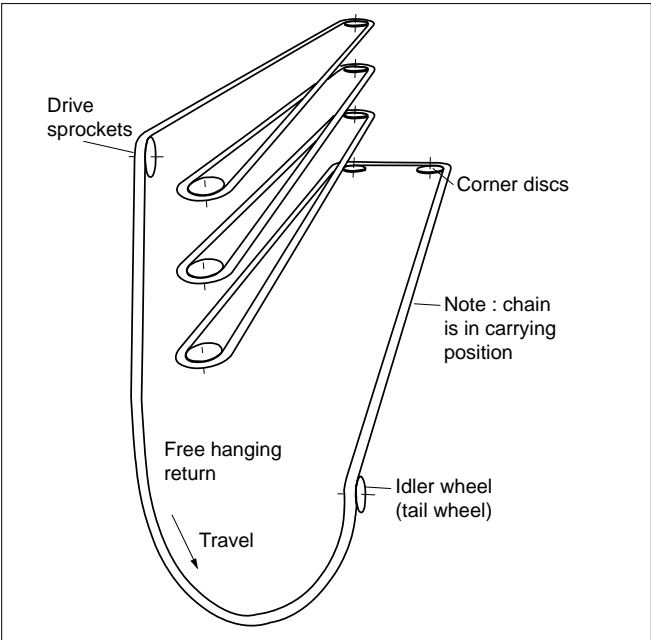

Fig. 22- Sideflexing return on typical elevator

Product transfer

In order to prevent the products from falling over, the out-feed chain must be at the same level or approximately 1 mm lower than the infeed chain. Simple switch systems can be used at different transfer points for a continuous distribution of the products to different locations in the plant (see Figures 23 and 24). The flexibility of Multiflex chains allows the use of different types of transfer. Figures 25 and 26 show different transfers using the Multiflex chain 1700.

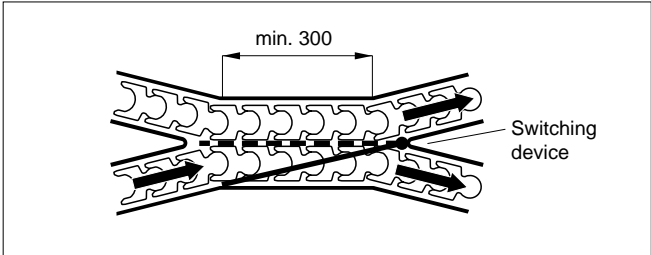

Fig. 23- Cross transfer. Using switches, the products can be transferred from one chain to the other, or transported further on the same chain.

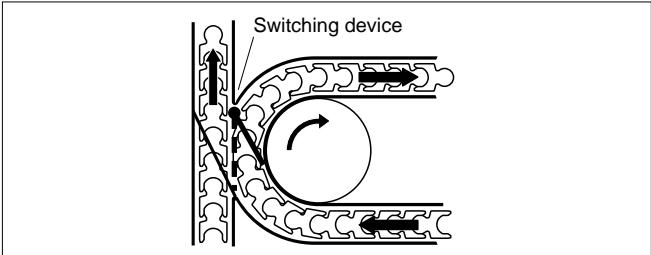

Fig. 24- Curve transfer

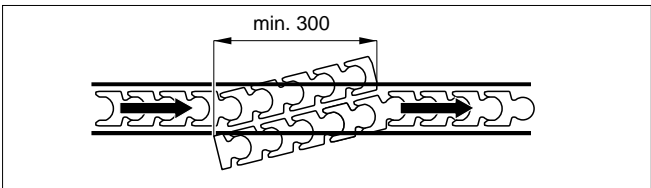

Fig. 25- Transfer point where products are transported further in a straight line.

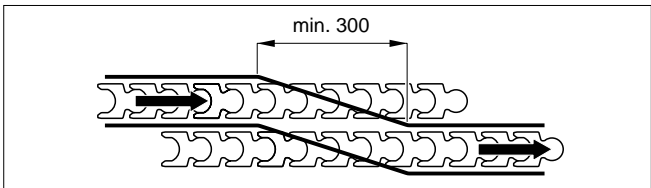

Fig. 26- Transfer point where products move sideways from one chain to another

Conveyor Design

Multiflex Chains

Multi incline conveyors

As mentioned above, Multiflex chains are ideal for multi-incline conveyors. For smooth operation, the following factors are of importance:

- 1) That the chain is on the same level as the corner disc,
- 2) That the change in angle is achieved by bending the chain downwards not upwards - as this would cause the chain to lift out of the frame (see Figures 27 and 28).

The maximum incline for the 1700 chain should not exceed 100 mm per metre. The actual incline for a given application depends on the stability of the product being transported and on the coefficient of friction between product and chain.

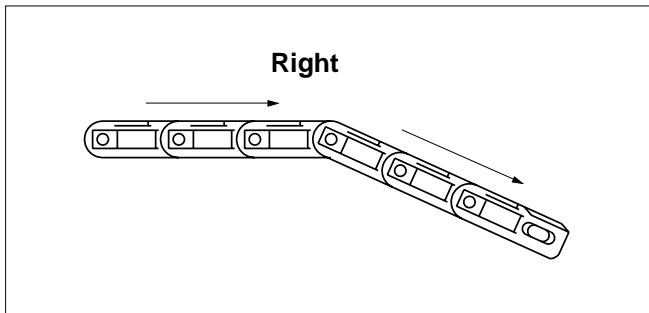

Fig. 27- Chain downflexing

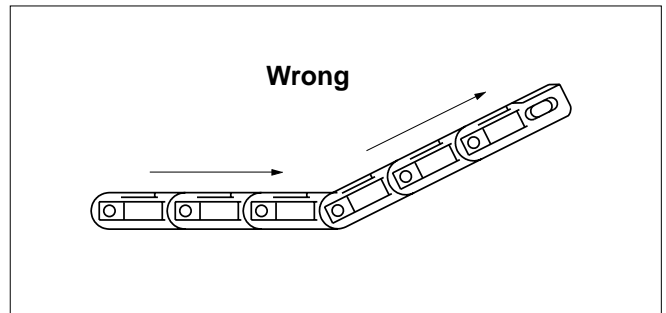

Fig. 28- Chain backflexing

ON AN INCLINE, the chain must pass through a transition zone before entering the disc. The disc should be tilted slightly so that it lies in the same plane as the outfeeding chain. Aside from this, attention should be given to the minimum spacing (M) (see figure 29)

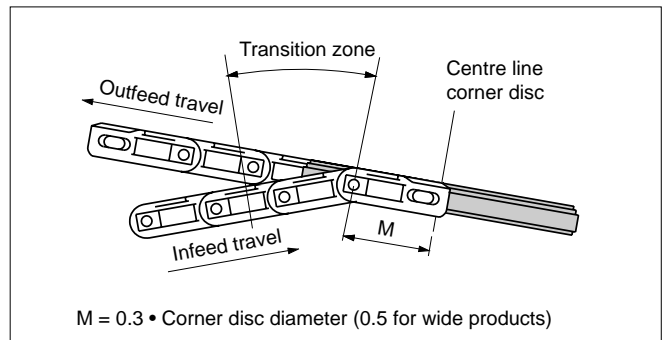

Fig. 29- Side view of incline conveyor at corner disc.

In order that the chain lies in the same plane as the infeeding chain, **ON A DECLINE**, after leaving the disc, the chain must pass through a transition zone. Aside from this, on outfeed, attention should be given to the minimum spacing (M) (see Figure 30)

Note

in order to obtain a smooth transition from one conveying plane to another in the transition zone, the wear strips should be curved.

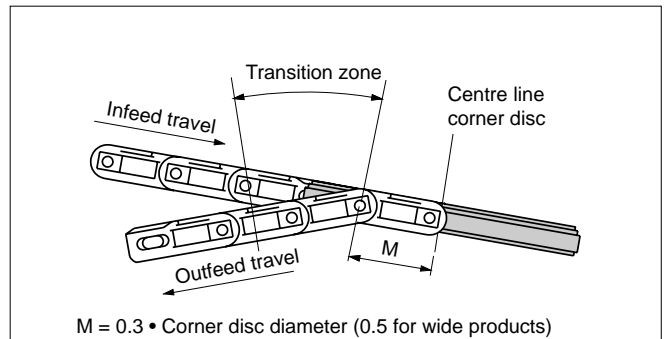

Fig. 30- Side view of decline conveyor at corner disc.

Conveyor Design

Multiflex Chains Series 3150

Carrying ways

Straight run

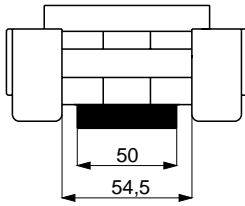

Corner sections

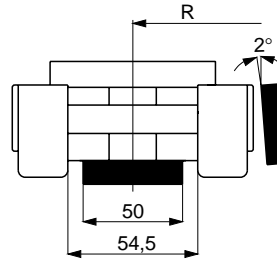

Return ways

Example 1

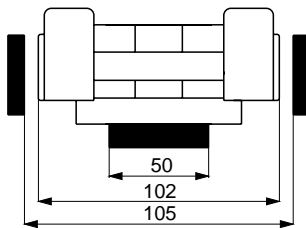

Example 2

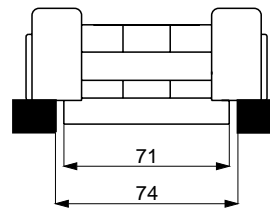

Sprockets

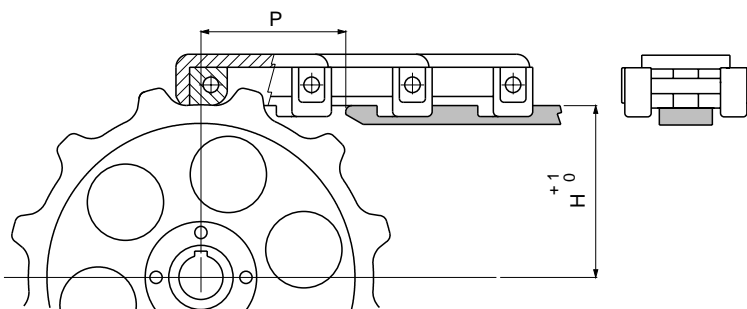

Chain No.	H - mm	P - mm
3150	(Dp:2) - 16,9	90

Dp = primitive diameter of drive sprocket - mm.

Table 8- dimensions H and P

Conveyor Design

Special Chains Series 1080

Straight running

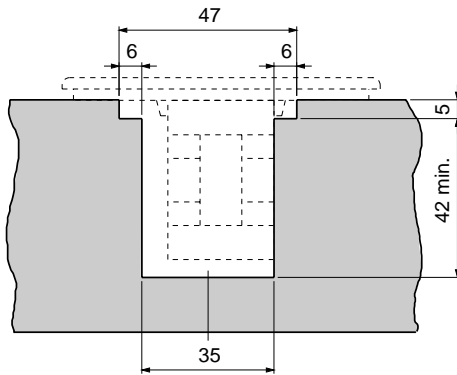

Corner section

Example 1

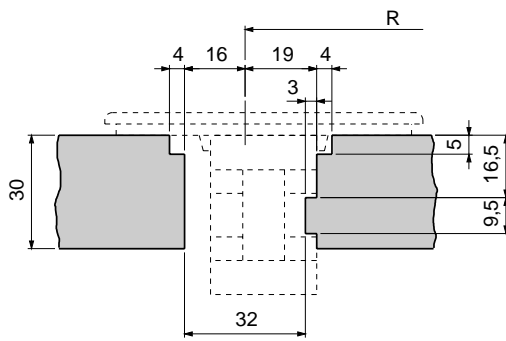

Example 2

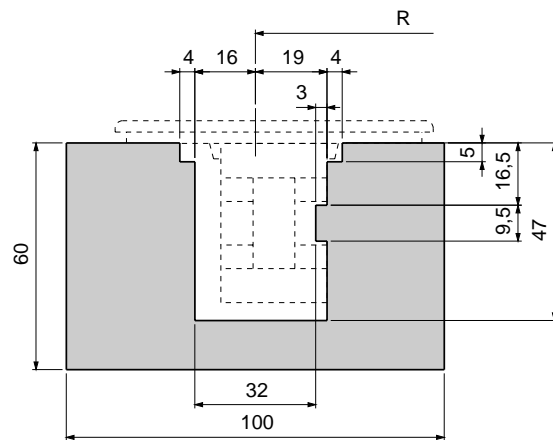

Conveyor Design

Low Backline Pressure Chains

Different Returnpart constructions

Return for use with
SLBP 821 and SLBP 882 TAB

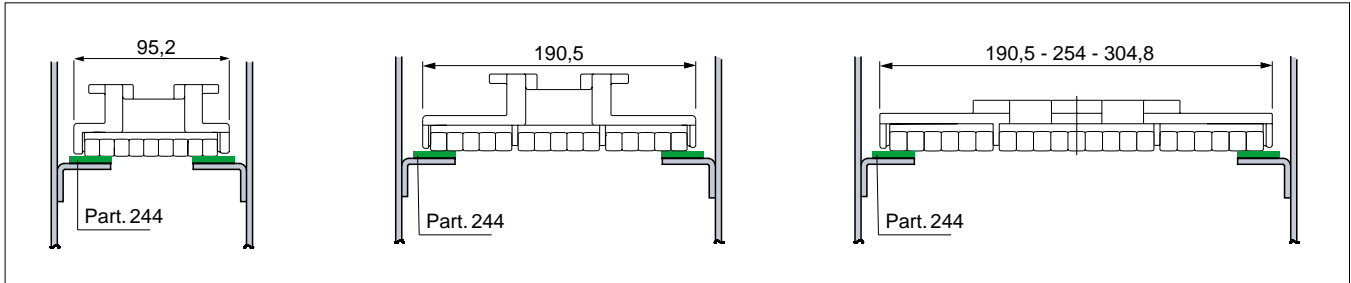

TAB-stile return for
SLBP 882 TAB and LBP 883 TAB chains

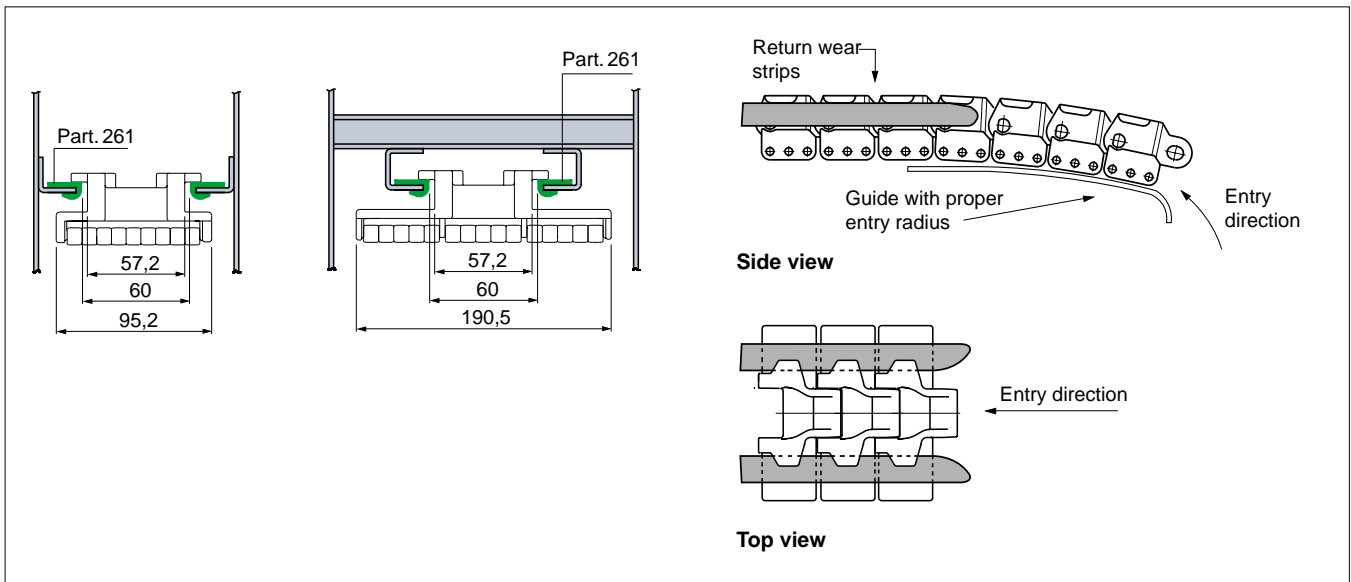

Product Handling

Maximum recommended conveyor length

The length of a conveyor is not unlimited. There is a certain maximum length for each application. The limits are depending on factors like chain- type, lubrication, kind of product, load.

Generally we have good experiences with maximum tracklength of 12 meters.

Note

On long conveyors, it is recommended to place curves as close to the idler end as possible. This way the chain load in the curve is minimum, resulting in a longer wearlife.

Although longer conveyors mean fewer drives and therefore fewer initials cost, the theoretically calculated maximum conveyor length is not always the optimum conveyor length. For this, there can be several reasons: the available space, control facilities of the conveyor and the backline pressure. Other reason for building conveyors with a shorter conveyor length than maximum are shown below.

Wearlife

A higher chainload will result in higher wear of all conveyor components, as wear is related to the load, speed and running time.

Slip stick effects

Slip-stick is caused by the difference between static friction and dynamic friction. Slip-stick effects can cause a pulsating chain operation. It is very hard to predict whether this phenomenon will occur or not. It depends on the speed, the load, the construction and lubrication. We have the experience that with long conveyor length, the chance of a pulsating operation increases. Therefore, a long conveyor length should be avoided in situations where an unwanted pulsating chain operation is not allowed.

Flow control facilities

Shorter conveyors are built to obtain lower backline pressure by means of better control facilities. The chainspeeds can be controlled using frequency controlled drives. When for instance one conveyor runs full, the chainspeed of the preceding conveyor can then slowly be decreased.

PlateTop chains generally allow for double length compared to conventional TableTop® chains.

Maximum recommended conveyor speeds

Optimum conveyor speed is important to achieve a high efficiency of the conveyor, but the chain speed is not unlimited. The criteria for conveyor speed and the width of the conveyor is the number of products which must be delivered to a location per unit of time. The infeed and outfeed of each process machine will dictate product flow width at the machine. But inbetween two machines the alternatives range from high speed single track to slow speed multiple tracks. In the table below a comparison is given.

Rexnord recommends not exceeding the maximum speeds for chains. Exceeding these speeds, will increase wear unacceptably and decrease the maximum working load. See table below for maximum recommended speeds.

Chain material and type	Maximum recommended speeds (m/min)		
	Dry	Water	Water and soap
Stainless steel chains, straight	50	70	130
Stainless steel chains, Magnetic System	30	40	130
Plastic chains, straight run	80	100	180
Plastic chains, Sideflex, Tab	*	60	120
Plastic chains, Magnetic System	*	90	180
PlateTop chains	100	120	240

* = No maximum speed is given here. These values depend on the PV-value of the curve. This value represent the pressure in combination with the velocity and is a value for the amount of heat development and melting of materials. The calculation programme will calculate this value automatically and show recommendations.

Table 9- Maximum recommended speeds of Rex chains

Note

These values represent general conditions. In e.g. abrasive conditions the maximum speeds will decrease.

Reducing build up of static electricity

In dry applications where products are being conveyed on plastic chains, especially when accumulation occurs, sometimes an electrostatical charge can be built up. This electrostatical charge can be inconvenient. It can cause attraction of dust and dirt or an electrical shock when somebody touches the conveyor or a product. It could also cause disturb to sensitive control devices.

In some cases, the electrostatical charge can even be dangerous. It is easy to image what a discharge in the shape of a spark can cause in explosive environments.

To reduce the risk of built up of electrostatical charges, two types of precautions can be taken : passive neutralisation and active neutralisation.

- Passive neutralisation means that the electrical charge is avoided by grounding the complete conveyor (chains, wearstrips, frame and components).
- Active neutralisation means that a positive electrostatical charge is neutralised by negative ions. An easy method is blowing ionised air over the chain and product.

The best way to eliminate build up of static electricity is using steel chains instead of plastic chains. However this is not always possible. Therefore Rexnord has Anti Static plastic chain in the programme. This available material is electrically conductive.

Note

The Anti Static chain must be used in combination with grounded metal wearstrips.

The AS-material that is used for anti static chains has the following properties

Property	AS Polyacetal	Standard Anti static material by DIN 53482
Surface resistance	$\leq 5 \cdot 10^3 \Omega/\square$	$\leq 10^9 \Omega/\square$
Volume resistance	$\leq 10^3 \Omega.cm$	$\leq 10^8 \Omega.cm$

Other precautions to reduce the risk of electrostatical charges can be :

- Apply lubrication if possible;
- Use anti-static or metal wearstrips, guiderails etc. wherever possible and make sure all metal parts are grounded;
- Avoid product accumulation;
- Avoid slip contacts (make sure that idlers and return rollers are rotating).

Calculate product stability

Each product has a maximum value for acceleration. Start-stop or stop-start conditions are related to the product stability. There are formulas to calculate the stability of a product. On a basis of the outcome of the calculations, it is possible to determine if a 90° deadplate transfer or a Dynamic Transfer System™ can be used or whether a Magnetic System is the only suitable solution. Of every product a so-called critical friction coefficient can be calculated. This critical friction coefficient is the quotient of the radius of the base and the height of the centre of gravity.

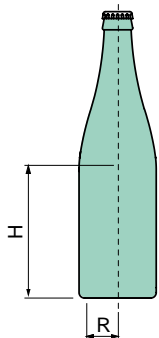

In formula : $f_{crit} = R/H$

The critical friction coefficient thus calculated must be compared with the real friction coefficient which is valid in practice (f_{real}). The real friction coefficient strongly depends on product and conditions. It would be best to measure the real friction coefficient for the application in question.

This has been done numerous times at the Rexnord test centre. Experience has shown that, for the same product and in the same conditions, the friction coefficient can still vary within a differential of 30%.

Now, f_{crit} and f_{real} must be compared with each other. The criteria is that if $f_{crit} > f_{real}$, the stability of the product is sufficient. This means that the product will remain standing stable, even when it is subject to large variations in speed. It will be obvious that obstacles in the conveyor, such as a raised edge for example, still have to be avoided. Please take into account that dirt affects the friction coefficient in practice. Besides, the lubrication may not always be optimum.

If $f_{crit} < f_{real}$, this does not immediately imply that transport is not possible. In order to guarantee the stability, however, a maximum variation in speed to which the product can be subjected without tipping must be calculated. In a formula :

$$V_{lim} = \sqrt{2 \cdot g \cdot (\sqrt{H^2 + R^2} - H)}$$

V_{lim} = Maximum variation in speed [m/s]
 R = Radius of the base [m]
 H = Height of the centre of gravity [m]
 g = Gravitational acceleration [m/s²]

With a deadplate and Dynamic Transfer System™, it may be assumed that the speed of the product will be reduced to almost nil, after which it will be transferred continuously at the full speed of the "outgoing" chain. The speed of the outgoing chain must therefore be lower than V_{lim} to allow for a deadplate transfer.

Product Handling

Reducing noise

In many countries regulations dictate a certain absolute sound level at a workplace. In industrial buildings like breweries where glass is involved, the noise level could be very high at some places. In general there are three areas where something can be done to reduce the noise level : Machines, conveyors and the building itself.

The highest noise levels on conveyors are the result of unfavourable product handling. Collision of bottles against each other or against guiderails produces noise. Increasingly high speeds of bottling lines result in an increase of the noise level, due to the higher collision speed.

Several measures can be taken to reduce the noise level of products.

- 1) Use curves instead of deadplate transfer. A Dynamic Transfer System™ (refer to our MatTop® catalogue) is much better than a dead plate transfer, also in terms of noise. However, a curve is the optimum solution.
- 2) Bottles should be handled with care. On zero-pressure combiners, bottles will smoothly move into one row, producing a low noise level. Careful handling is also in the interest of less scuffing and less bottle breakage.
- 3) Good flow control possibilities, which can be obtained by building conveyors with a certain maximum length. The chainspeed can be controlled by using PLC's and frequency controlled drives. When for instance one conveyor runs full, the chainspeed on the preceding conveyor can be decreased.
- 4) Cover guiderails and other components with plastic profiles. In general, plastic materials can result in a decrease of the noise level, compared to metal in contact with glass.
- 5) Use plastic sprockets and idlers.
- 6) Use plastic wearstrips in combination with stainless steel chains.
- 7) When the return part is executed with return rollers, it is recommended to use rollers with a large diameter of +/- 60 mm. The use of small rollers could result in a rattling sound. Rollers with a rubber surface are available. They will contribute to a lower noise level.
- 8) Plastic chains running dry in curves can sometimes produce noise. In this respect Magnetic System is better than Tab curves. If the cause of the noise cannot be located, consider lubrication.

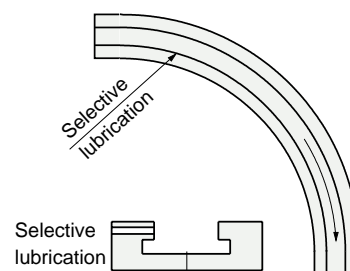

Maximum temperatures

It is important to check the materials regarding the allowable temperatures. In the Rex catalogue and calculation program, product specifications are based on a temperature of 21°C. When the environmental temperature differs significantly, this will influence the mechanical properties and thermal expansion of chains. This is especially important on plastic products.

In the table below the minimum and maximum temperatures are given for materials. A continuous exceeding of these temperatures can result in product failure.

Chain material and type	Allowable temperature	
	T min (°C)	T max (°C)
Stainless steel chains	-70	430
Hardened steel chains	-40	180
Stainless steel rubber top chains	-35	100
Acetal plastic chains, dry	-40	80
Acetal plastic chains, wet	-40	65

Table 10- Allowable temperatures

Thermal expansion

Please be aware that plastic chains and belts expand or contract more than metal parts due to temperature changes.

The coefficient of thermal expansion of the plastics are:

Material	Coefficient of thermal expansion
Acetal LF, HP	0.12 mm/m/°C
AS- material	0.13 mm/m/°C
WPP- material	0.15 mm/m/°C

Table 11- Coefficient of thermal expansion

Environmental Conditions

Chemical resistance

For plastic chains, no cleaning agents with a pH value of less than 4 (acidic) or over 10 (alkali), or chemical containing free chlorine or ammonia should be used. Due to evaporation, these substances may corrode the material or have a negative effect on various processes. In the case of polycarbonate, hydrocarbons and solvents should also be avoided. refer to the following corrosion and resistance guide.

CHEMICAL AGENT	Rex -OPTI-Plus® AISI 430		AISI 304		Rex-HP™ Rex-LF® ACETAL D		POLYPROPYLENE PP		POLYAMIDE PA		POLYETHYLENE PE	
	Conc.%	23° C	Conc.%	23° C	Conc.%	23° C	Conc.%	23° C	Conc.%	23° C	Conc.%	23° C
ACETIC ACID	20	-	20	+	5	-	40	+	100	+	10	+
ACETONE	100	+	50	+	/			+	100	+		+
ALUMINIUM CHLORIDE				-					10	+		
AMMONIA	50	+	50	+	Sol.	+	30	+	10	+		+
AMMONIA CONC.						-		+	10	+		+
AMMONIUM CHLORIDE			10	/					10	+		
AMYL ALCOHOL				+				+	100	+		
ANILINE	3	+	3	+	3	+	100	+	/		3	+
BEER		+		+		+		+		+		+
BENZENE	70	/	70	/		+		+		+		/
BENZOIC ACID			100	/			Sat.	+	Sat.	/		
BENZOL		+		+		+		/	100	+		/
BORIC ACID	100	/	100	/		+	Sat.	+	10	+	Sat.	+
BRINE		-				/	Sat.	+		/		+
BUTTER		+		+		+		+		+		+
BUTYL ALCOHOL				+					100	+		
BUTYRIC ACID	5	+	5	+		-	100	+		-		+
CALCIUM CHLORIDE	10	-	10	-		/	50	+	10	+	Sat.	+
CARBON SULPHIDE		/		+		+		+	100	+		+
CARBON TETRACHLORIDE	10	-	10	-		+		-		+		/
CAUSTIC SODA		+		+	25	-	52	+	10	+	25	+
CHEESE						+		+		-		+
CHLORINATED WATER		-		-		-		-		+		-
CHLOROFORM	100	/	100	+		-		/	100	-		-
CHOCOLATE						+				-		+
CITRIC ACID	5	+	5	+		/	10	+	10	/		+
CUPRIC SULPHATE	5	+	5	+		+	Sat.	+	10	+		+
DISTILLED WATER		+		+		+		+		+		+
ETHYL ACETAT			100	/				+	100	+		
ETHYL ALCOHOL	10	/	10	+		+	96	+	96	+		+
ETHYL CHLORIDE		+		+		+		-	100	+		/
ETHYL ETHER						+		+	100	+		+
FERRIC CHLORIDE			20	-				+	10	+		
FOOD FATS		+		+		+		+		+		+
FOOD OILS		+		+		+		+		+		+
FORMALDEHYDE	100	/	100	+		+	40	+	30	+		/
FORMIC ACID	5	-	5	/	10	-	100	+	10	-	10	+
FREON 12				+						+		
FRESH WATER		+		+		+		+		+		+
FRUIT JUICES		/		+		+		+		+		+
GASOLINE		+		+		+		/		+		/
GLYCERINE		/		+		+		+		+		+
HYDROCHLORIC ACID					2	/		+		-		+
HYDROCHLORIC ACID		-		-	37	-	30	+	10	-	37	+
HYDROFLUORIC ACID		-		-		-	40	+	40	-	70	+
HYDROGEN PEROXIDE	30	+	30	+		-	30	+	3	-		+
IODINE						+		+		-		+
LACTIC ACID	5	/	5	+		+	20	+	10	+		+
LINSEED OIL			100	+				+		+		
MAGNESIUM CHLORIDE			5	+			Sat.	+	10	+		
MERCURY	100	/	100	/		+	100	+		+		+
METHYL ALCOHOL	100	/	100	/		+		+	100	+		+
METHYLENE CHLORIDE		/		/		-		/	100	+		/
MILK		+		+		+		+		+		+
MINERAL OILS		+		+		+		+		+		+

Environmental Conditions

Chemical resistance

CHEMICAL AGENT	Rex -OPTI-Plus® AISI 430		AISI 304		Rex - HP™ Rex - LF® ACETAL D		POLYPROPYLENE PP		POLYAMIDE PA		POLYETHYLENE PE	
	Conc.%	23° C	Conc.%	23° C	Conc.%	23° C	Conc.%	23° C	Conc.%	23° C	Conc.%	23° C
MUSTARD						+		+		-		+
NITRIC ACID	10	/	10	+	5	-		+	10	-	5	/
OLEIC ACID	100	/	100	/		-		+	100	+		/
PARAFFIN		+		+		+	100	/		+		+
PETROLEUM		+		+		+	100	/		+		-
PETROLEUM ETHER				+		+		+		+		+
PHENOL			10	+				+		-		
PHOSFORIC ACID	10	-	10	-	10	-	85	+	10	-	95	+
POTASSIUM HYDROXIDE			50	+					10	+		
SEA WATER		-		+		/		+		+		+
SILICONE OIL								+		+		
SILVER NITRATE			60	/			20	+		+		
SOAP AND WATER		+		+		+		+		+		+
SODIUM CARBONATE	5	+	5	+		+	Sat.	+	10	+		+
SODIUM CHLORIDE	5	/	5	+		+	Sat.	+	10	+		+
SODIUM HYDROXIDE				-	10	+	30	+	10	+		+
SODIUM HYPOCHLORITE		-		-		-	20	+		+		+
SODIUM SILICATE			100	+						+		
SODIUM SULPHATE	5	+	5	+		+	Sat.	+	10	+		+
SOFT DRINKS		+		+		+		+		+		+
SUDS								+		+		
SULPHURIC ACID	10	-	10	-	40	-	98	+	10	-	40	/
TARTARIC ACID	10	+	10	+	30	/	10	+		+		+
TETRALINE								-		+		
TINCTURE OF IODINE						+		+		-		+
TRANSFORMER OIL								/		+		
TRICHLOROETHYLENE		+		+		-		/		/		+
TURPENTINE		+		+		-		-		/		-
VASELINE						+		+		+		/
VEGETABLE JUICES		+		+		+		+		+		+
VEGETABLE OILS		+		+		+		+		+		+
VINEGAR		+		+		+		+		+		+
WHISKY		/		+		+		+		+		+
WINE		+		+		+		+		+		+
XILOL		+		+		+		-		+		/
ZINC CHLORIDE			10	-			20	+	10	/		

Abbreviations: Sat. = saturated.

Legend..

- + = Good resistance.
 - / = Fairly good resistance (limited use depending on working conditions).
 - = Poor resistance (not recommended).
- N.B. Where tests have not been carried out the spaces are left blank.

The data shown in this table..

are taken from laboratory tests, performed on unstrained test samples. It should be considered as purely indicative since material behaviour under real working conditions depends on different factors: temperature, concentration of the chemical agent, quick or long-lasting effect of the chemical agent.

Environmental Conditions

Assembly and installation

Pull a short section of chain through the entire conveyor to detect any obstructions or areas of tight clearance. Check the conveyor for loose nuts, bolts and any projections.

Ensure that the joints in the wear strips and the support elements are even, and that the clearance between chain and chain guides is correct. Welding metal splashes, metal chips and paint must be removed from the sliding surfaces.

Check also the clearance between chain and guide rail. Ensure that sprockets and idler wheels are correctly aligned. ensure that the entire length of the chain is properly lubricated.

CAUTION:

Install chain in 3 metre sections, making all connections on the conveyor frame. Thread chain onto conveyor carefully to avoid twisting and possible damage to the chain.

Inspection

During day to day operation, the chain, sprockets and conveyor system must be regularly inspected. This prevents defects and allows repairs to be carried out before serious damage is caused. The cost of regular maintenance is more than paid for by the longer service life and the absence of breakdown in the functioning of the conveyor. In order that any adjustments can be carried out at once, additional checks should be carried out during the initial phase. When the preliminary phase is over, only routine inspections are necessary. A fixed inspection schedule should be drawn up:

- 1) Are there any unusual grooves on the chain?
- 2) Check that the surface of the chain is even.
- 3) Check the clearance between the individual links and ensure that this has not increased as a result of overloading or blocking.
- 4) Pulsating is a sign of insufficient lubrication or of catching by the chain.
- 5) Check the clearance of deadplates and turntables.
- 6) Do the sprockets show signs of excessive wear?
- 7) Is dirt accumulating between sprocket teeth?
- 8) Check for sprocket guide ring wear and chain misalignment.
- 9) Check the ways and wear strips for excessive wear.
- 10) Is the lubrication system working correctly?
- 11) Check the insides of the corner wear strips and chain guides- excessive heat may indicate tight clearance or high friction.
- 12) Check return rollers for free rotation.

Lubrication

Special attention should be paid to lubrication. Ensure that there is sufficient lubricant on all areas of the chain and wear strip. Continuous lubrication or application of the lubricant at regular intervals should be provided. Continuous and even lubrication is especially important at the entry to a corner. If the conveyor cannot be lubricated during operation, this should be carried out when it is at a standstill. The service life of sideflexing chains can be considerably increased by the application of light mineral oil to the sliding surfaces before assembly. In the case of sideflexing TableTop® chains, the roller chain should also be oiled before assembly.

Some lubrication processes and materials are listed below.

LUBRICATING AGENTS

1) Oil Based Lubricant

These are vegetable or mineral oils which have a high lubricity and coat chain parts which are subject to corrosion. If possible, lubricants of this type should be used for all metal chains.

2) Synthetic lubricants

Concentration is not depending on water hardness. Less foam on the conveyor, which makes inspection more easy. No slippery factory floors. Less bacteria growth.

3) Soap based lubricants

Best possible lubrication because the lubrication sticks on the chains. Feels more greasy. High concentration is less critical.

4) Water

Although pure water is much less effective than the above types, pure water can also be used as a lubricant. In the case of plastic chains which run on stainless steel guides, this may increase the load on the chain since a thin film of water must constantly be sheared.

METHODS OF LUBRICATION

- 1) A central lubrication system pumps lubricant to the required locations.
- 2) Sideflexing chains can be lubricated effectively by applying the lubricant at the entry to the curve directly between chain and wear strip.
- 3) The return chain passes through a bath of lubricant
- 4) The returning chain contacts wheels made of porous material which turn in a bath of lubricant.
- 5) The lubricant drips on to the chain from a tank suspended above it.
- 6) Water drips onto soap and then onto the chain.

DRY RUNNING CONVEYORS

In some positions in a bottling or canning line, running without lubrication is possible. Rexnord has experience with plastic chains in applications with no lubrication. Important aspects of running dry running conveyors are :

- + Savings will be made on investments in lubrication system such as dosing equipment.
- + Elimination of costs of lubricants, clean water and water treatment.
- + Improvement of plant safety due to the elimination of slippery factory floors.
- + No packaging damage caused by wet containers.
- + Biological Oxygen Demand- reduction resulting in a more environment friendly production plant.
- Coefficient of friction increases. Lubrication provides the best product handling.
- Extra cleaning may be necessary, otherwise the coefficient of friction increases.
- Extra wear on components like chains, wearstrips and drives.
- Chance of slip stick effect under certain conditions.
- Chance of built up of static electricity.
- Higher noise level (sometimes a creaking sound running plastic chains in curves).
- Not possible on high speed running conveyors.

Note

It is strongly recommended to clean dry running conveyors regularly. Dirt and debris must be removed by cleaning, in order to keep the friction coefficients between chains optimal.

Environmental Conditions

Repair and replacement

Should such faults as jerky running of the chain, excessive wear on the chain, projection of chain links be noticed, these should be repaired immediately.

Such faults are often due to one of the following causes:

- 1) Serious overloading, jam-ups or wedging caused by broken glass or bottle caps.
- 2) Excessive backflexing of the chain during return.
- 3) Inadequate or no lubrication.
- 4) Interference and obstruction.
- 5) Worn sprockets.
- 6) Poor conveyor design.
- 7) Seriously damaged or worn chain.
- 8) Inadequate clearance on deadplates and turntables.
- 9) Wear on sprocket guide rings or idler wheels.
- 10) Wear of wear strips on straight or curved sections.

The following guide lines should be observed in determining when to replace chains and sprockets:

- 1) Elongation of the chain by more than 30 mm per metre.
- 2) The chain jumps the sprocket.
- 3) The flights have worn to about one-half of the original thickness.
- 4) Uneven conveying surface.
- 5) Serious wear on the guides of sideflexing chains which causes pins protrusion - these may cause damage to the wear strips or other parts of the conveyor.

The sprocket is worn when indentations appear in the tothing on which the chain tends to catch. These recommendations for the care of the conveyor are intended to ensure its smooth and uninterrupted operation. Regular and punctual maintenance of the conveyor are an essential factor in its ultimate productivity.

Cleaning

In many applications, residues of grease, dirt, sand, spilled syrup, beverage etc. may accumulate and cause:

- 1) Contamination or damage to the products.
- 2) Additional load on the chain and the motor.
- 3) Accelerated wear on the sprocket teeth.
- 4) Jerky running of the conveyor and additional wear.
- 5) Increased wear on the plates and in the chain hinge.
- 6) Rapid wear of the wear strips.

Frequent cleaning of the chain and the conveyor is recommended. Steam, warm water and soap are generally used for this purpose. Strongly corrosive agents which may be used for steel chains should not be used for chains consisting of plastic material. If large quantities of syrup or other liquids, broken glass etc. have accumulated, the conveyor should be cleaned and all foreign material removed. In order to immediately remove broken glass, spilled liquid, etc., operating personnel should be provided with brushes and other cleaning materials.

Responsibility

Information in this manual is given as help and service for our customers. Rexnord does not guarantee precision, updating and specific applicability of the information and rejects any responsibility on damages to property or injuries to person(s) directly or indirectly coming from wrong conveyor design, installation or improper use of our products made with or without reference to the information herewith reported.

It is responsibility of the purchaser to provide proper guards, safety devices and procedures as recommended by safety codes and safety standards.

Rexnord does not guarantee the design and function of machines equipped with our products are compliant with applicable local, european or USA federal health and safety laws or regulations.

Installation & Maintenance

Chain jumps on the sprocket or does not release well

Possible causes

Chain is elongated or sprocket is worn-out. Elongation of the chain can be caused by wear or due to severe overloading, caused by e.g. jams.

Improper catenary sag.

Sprocket is worn (teeth show a hooked profile).

Wrong sprocket type is installed

Improper sprocket position

Remedy

Replace chain and sprocket and check also other conveyor components for severe wear to find exact cause.

Make sure catenary sag is in right position and has the correct dimension

Replace sprockets.

Install right sprockets.

Position sprockets at the right height and distance from the wearstrips.

Jerky chain operation

Possible causes

This problem can occur with relatively long conveyors, operating at relatively low speeds. This is usually caused by so called "slip stick" effects, which are caused by the differences between the dynamic and static coefficient of friction.

Return roller diameter is too small.

Chain catches the conveyor.

Remedy

Use lubrication if possible.
Reduce chain tension by shortening the conveyor.

Install larger diameter roller.

Remove obstructions in the conveyor and make sure the chain moves smoothly in the returnpart.

Chain hinges are damaged

Possible causes

Severe rapid elongation of the chain is usually caused by overloading, due to jams.

Blocking and obstruction in conveyor.

Exceeding the minimum backflex radius of the chain in the return section.

Remedy

Replace chain and check other conveyor components like sprockets, also for severe wear.

Check the conveyor for possible obstructions, by pulling a small piece of chain through the conveyor manually.

Install larger rollers in positions where chains are bent excessively in backflex radius.

Chain is elongated

Possible causes

Dirty hinges

Remedy

Clean chain thoroughly and improve cleaning procedure.

Rapid curve wear

Possible causes

In dry running lines with plastic chains, the PV limit can be exceeded.

In lubricated lines with abrasive particles (stainless steel chains). These particles can be the cause.

Remedy

Check application with calculation programme and replace curve upperpart by NYLATRON upperpart if programme dictates so.

Replace upperpart by NYLATRON upperpart.

Installation & Maintenance

Chain is drifting sideways on sprocket

Possible causes

- Bad shaft/sprocket alignment.
- Conveyors not level.
- Poor design of carrying track or return section, near sprocket.

Remedy

- Improve shaft/sprocket alignment and/or use guiderings.
- Put the conveyor level.
- Change construction according to the guidelines in this manual

Cracked hinge eyes of plastic chain

Possible causes

- If the chain shows small cracks on the outside hinge eyes, this is usually caused by so-called stress-corrosion. The combination of chain load and the influence of chemicals can cause haircracks on the hinge eyes.

Remedy

- Replace chain and use only compatible chemicals.

Magnetic System chains come out of curve

Possible causes

- Uneven wear of the curve groove.
- Improper chamfering of infeed or other obstructions in conveyor track where chains catches the conveyor frame.
- No controlled startup.
- Curve is not mounted level.

Remedy

- Replace curve.
- Make sure the chain can run smoothly through the complete section and check for obstructions.
- Install a frequency controlled start and stop installation.
- Check recommendations given regarding the installation of Magnetic curves.

Steel chain is rusted

Possible causes

- Chain is not, or limited resistant to the liquid to which it has been exposed. Cleaning agents e.g. can sometimes be very aggressive.

Remedy

- Use only compatible chemicals.
- Consider installing a stainless steel chain with improve corrosion resistance.

Excessive chain wear

Possible causes

- Pollution.
- Failing lubrication.
- Obstruction in conveyor.
- Debris in returnpart.

Remedy

- Clean conveyor thoroughly and improve cleaning procedure.
- Contact supplier of lubricant to improve lubrication.
- Find obstruction and remove it.
- Cleaning and/or use rollers with a larger diameter.

Note

Of course, this table is not complete. For specific problems which cannot be solved this way, contact Rexnord Marbett or your nearest distributor for advice.

Numerical Index

Series	Page	Series	Page	Series	Page
512	10	A 600	57	N 1700	80
802	9	A 600 TAB	57	N 1700 AS	80
805	9	A 1400	57	ND 1700	85
812	9	A 1400 TAB	57	ND 1700 B	84
815	9	AC 1700 K	49	ND 1700 FL	86
820	15	AL 3150	81	NS 815	63
820 Vacuum	61	COMBI	91	NS 820	70
821	16	COMBI 500	92	NS 821	66-72
831	16	COMBI 600	92	NS 831	70
843	25	EP 1700	86	NS 880	74
845	25	FGM 1050	20	NS 881	68
879	17	FTM 1050	20	NS 882	76
879 BO	19	FTM 1055	21	NS 1050	78
879 TAB	18	GG 600	79	NSX 821	67-73
880	17	GG 820	64-71	NSX 880	75
880 BO	19	GG 821	66-72	NSX 881	69
880 BO F	60	GG 880	74	NSX 882	77
880 BO GB	41	GG 881	68	NSX 1050	78
880 GB	41	GG 882	76	NSXT 820	65-69-71-75
880 MG	22	GG 1400	79	NX 800	67
880 TAB	18	GG 1755	81	NX 880	75
880 TAB-K454	22	HFP 820	31	NX 880 BO	83
880 TAB Vacuum	61	HFP 821	31	NX 881	69
881 M	12	HFP 821 F	35	NX 1108	82
882	24	HFP 879 BO	33	NX 1700	81
882 TAB	24	HFP 880 BOT	32	NX 1700 AS	81
963	26	HFP 880 TAB	32	NXT 820	65-69-71-75
1080	59	HFP 882 TAB	33	NXT 821	73
1108	59	HFP 882 TAB F	35	NXT 880 BO	83
1700 K	48	HFP 1873 TAB	34	RR 882	23
1700 TAB K	48	KMU	91	S 815	64
1702	51	KSU	87	SLBP 821	43
1710 K	54	KSU 200	88	SLBP 882 TAB	44
1710 TAB K	54	KTU	89	SS 815	64
1713 K	55	KTU 200	90-94	SS 1700	80
1713 TAB K	55	KTU 300	93	SS 1700 AS	80
1716 K	51	KTU 500	95	SSC 802	30
1720 K	47	KU 600	79	SSC 8811 TAB	30
1755	52	KU 815	64	SSR 812	29
1765 ZeroGap™	47	KU 820	70	SSR 812-K125	10
1790 K	50	KU 821	66-72	SSR 812-K175	10
1790 TAB K	50	KU 880	74	SSR 812 TAB	29
1843	26	KU 881	68	SSU	87
1843 G	38	KU 882	76	ST 512	67
1864	13	KU 1700	80	ST 1080	82
1873	27	KU 1755 US	86	STU	89
1873 G	40	KUS 815	63	STU 200	90-94
1873 GJM	40	KUS 820	70	STU 300	93
1873 GSD	38	KUS 821	66-72	STU 500	95
1873 GS2J	39	KUS 881	68	XLBP 831	43
1873 GS3J	39	KUS 1050	78	ZN 1700	80
1874 TAB	13	KXT 800	67	ZN 1700 AS	80
1874 G	37	LBP 879 BO	45		
1874 HDG	37	LBP 883	45		
3150	53	N 800	66		
3873	27	N 820	63-70		
8811	11	N 821	72		
8811 BO	12	N 880 BO	83		
8811 TAB	11	N 1108	82		

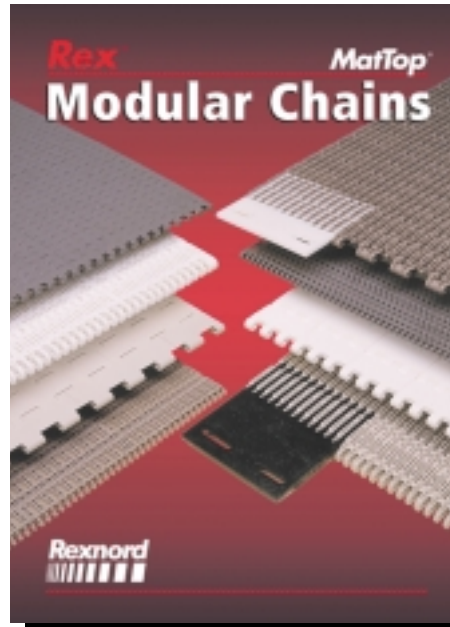
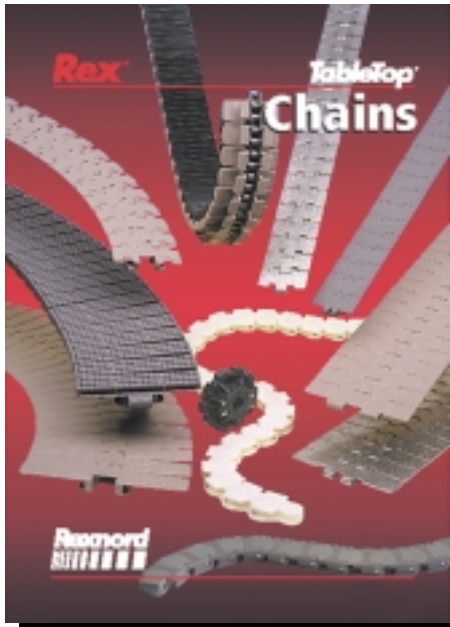

Reproduction, even partial, of this catalogue is illegal.

Rexnord Marbett is continually investigating methods of improving products and introducing new technology, we reserve the right to modify data and features shown in the catalogue. Dimensions are indicative only, for tolerances contact us.

For further technical information, please apply to our Technical Dept.

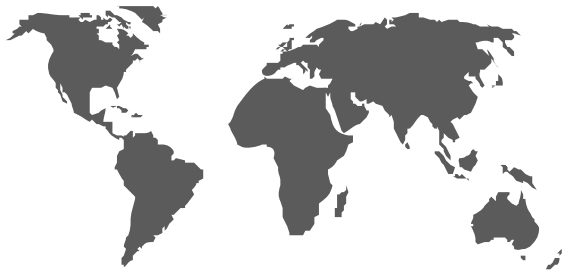

SALES OFFICES:

Austria	- Wien
Denmark	- Copenhagen
France	- Paris-Lyon
Germany	- Betzdorf (with distribution centre) - Düsseldorf - Siegen - Stuttgart
Italy	- Correggio (with distribution centre)
Netherlands	- 's-Gravenzande (with distribution centre)
United Kingdom	- Warrington
Canada	- Edmonton - Montreal - Toronto - Vancouver
United States	- Atlanta (GA) - Columbus (OH) - Dallas (TX) - Fresno (CA) - Grafton (WI)
Mexico	- Cordoba - Guadalajara - Mexico City - Queretaro
Brazil	- Sao Leopoldo - Sao Paulo
Australia	- Melbourne - Sydney
Singapore	- Singapore
China	- Shanghai



Rexnord Marbett s.r.l.

Via della Costituzione, 45
42015 Correggio (RE)

Italy

Tel. +39 0522 - 639333

Fax +39 0522 - 637778

info@rexnordmarbett.it

www.rexnordmarbett.com

Rexnord FlatTop Europe b.v.

P.O. Box 112

2690 AC 's-Gravenzande

The Netherlands

Phone +31 (0) 174 - 445111

Fax +31 (0) 174 - 445222

flattopeurope@rexnord.com

www.rexnordmcc.com