

Chains

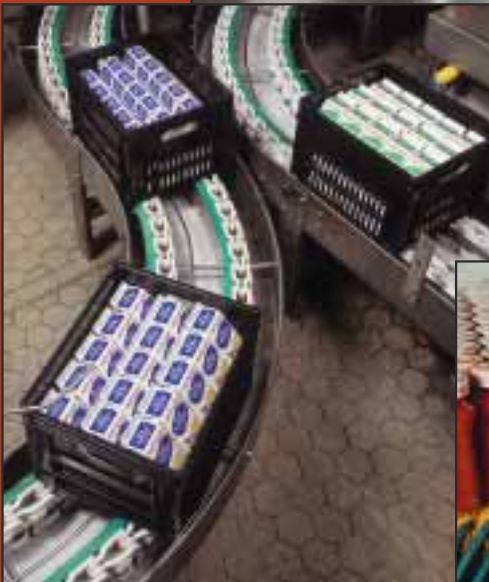

Belts



Curves



Sprockets

MCC INTRODUCTION

As the handling specialist for the beverage and food industry, Rexnord FlatTop Europe is ready to support you in every way of conveying. As a part of the Rexnord corporation we can supply you with the strong brands Rex®, Marbett® and MCC. In this catalogue you will find a presentation of the extensive range of MCC products.



HANDLING SPECIALIST REXNORD FLATTOP EUROPE; 24 HOURS A DAY AT YOUR DISPOSAL.

BENEFITS

- Handling specialist**
Skilled Engineers and Application Consultants will be pleased to find the answers to your questions concerning product handling.
- Products of excellent quality**
More than 40 years of experience have resulted in MCC products, setting the standards in the conveying industry. And in cooperation with OEMs, breweries and soft drink plants, Rexnord is continually developing new products. Several existing products have been patented in a large number of countries.
- Service**
Customer Service, Sales and Technical Support are completely at your disposal; for urgent deliveries, you can call us 24 hours per day, 365 days a year. Apart from English and Dutch, German, French, Spanish, Portuguese and Italian are also spoken.
- Quick delivery**
A lot of products are available from stock, so that Rexnord can guarantee you fast and reliable delivery; non-stock and tailor-made orders can be supplied in short term.

PROGRAMME

- Chains**
(Stainless) steel, stainless steel with rubber top, plastic, plastic SuperGrip, LBP, multiflex and case conveyor chains.
- Belts**
500-series, 1000-series, SuperGrip belts, heavy duty belts, 2000-series, glass pasteurizer belts, flexbelts, chainbelts and finger transfers.
- Curves**
Magnetflex® Combi-A, -G, -S, -L and CIP-curves, as well as tab curves.
- Sprockets**
Split and classic sprockets and idlers for chains and belts.
- Components**
Basic line of conveyor parts.



EXCELLENT PRODUCT QUALITY AS A RESULT OF CONTINUOUS RESEARCH, ALSO IN OUR TESTCENTRE.







AND . . .

The MCC products are available in different materials for different applications. Brand new is the additive  used in some chains and belts; ask our Technical Support product specialists for further details. With local representatives plus distributors all over the world, Rexnord is never far away. We would like to refer also to the catalogues Rex TableTop and MatTop, Marbett components, MB bearings, Robo supporting and levelling elements and our brochure for the food industry.

Most important changes in this catalogue in comparison with issue 7 are:

- 7956-series flexbelts now also available in 18" width; 30" will follow soon
- New Magnetflex® Combi-A curves for FTM 1055 K450 chainbelts
- Fixed brackets, swivel brackets, clamping blocks and guide rail profiles can be found in the Marbett components catalogue
- New DTS®-C transfer system for pasteurizers and accumulation tables

INDEX

		PAGE
	STEEL SLATBAND CHAINS	2
	STEEL SLATBAND CHAINS WITH RUBBER TOP	8
	PLASTIC SLATBAND CHAINS	12
	PLASTIC SLATBAND LBP CHAINS	20
	PLASTIC SUPERGRIP CHAINS	26
	PLASTIC MULTIFLEX CHAINS	30
	PLASTIC CASE CONVEYOR CHAINS	34
	500-SERIES MODULAR CONVEYOR BELTS	38
	1000-SERIES MODULAR CONVEYOR BELTS	40
	1000-SERIES SUPERGRIP BELTS	46
	1005-SERIES HEAVY DUTY BELTS	48
	1005-SERIES HEAVY DUTY LBP BELTS	50
	1005-SERIES HEAVY DUTY SUPERGRIP BELTS	52
	2000-SERIES MODULAR CONVEYOR BELTS	56
	2500-SERIES GLASS PASTEURIZER BELTS	60
	FLEXBELTS	62
	MAGNETFLEX® CHAINBELT SYSTEM	66
	FINGER TRANSFERS	70
	CURVES	74
	MAGNETFLEX® COMBI-A CURVES	76
	MAGNETFLEX® COMBI-A CURVES FOR LBP	95
	MAGNETFLEX® CIP CURVES	98
	MAGNETFLEX® COMBI-A CURVES FOR CHAINBELTS	100
	TAB CURVES	108
	SPLIT SPROCKETS AND IDLERS	110
	SPLIT SPROCKETS AND IDLERS FOR CHAINS	111
	SPLIT SPROCKETS AND IDLERS FOR BELTS	130
	CLASSIC SPROCKETS AND IDLERS	140
	CLASSIC SPROCKETS AND IDLERS FOR CHAINS	141
CLASSIC SPROCKETS AND IDLERS FOR BELTS	148	
	CONVEYOR COMPONENTS	156
	MATERIALS	158

The (stainless) steel slatband chain guarantees long lasting top performance.

This chain can be obtained in various materials and qualities, depending on your requirements. This makes (stainless) steel slatband chains ideal for all kind of bottle, 3-piece cans, container, keg and crate handling conveyors. Applications can be found in breweries, other beverage industries, glass factories and many others.



RELIABLE GLASS BOTTLE CONVEYOR WITH 60-SERIES STAR.

BENEFITS

- Optimum product handling**
The excellent surface finish (Slideline) and special shape (MAX-line) give super stability and sliding properties.
- High strength**
The special production method ensures a higher working load.
- Long wearlife**
The cold-rolling process and the special alloys give the chain a very hard surface, providing a long wearlife, even under abrasive, high-speed circumstances.

PROGRAMME

- 10-series, straight run and sideflex**
This chain is very suitable for general applications. It is made of a specially treated 17% chrome stainless steel (AISI 430). Because of the special production method, it offers a long wearlife and high strength, together with fine sliding properties. 10-Series is corrosion-resistant.
- 18-series, straight run**
This chain is very suitable for applications involving chemicals. Its material is based on an 18/8 chrome nickel stainless steel (AISI 304). It offers superior corrosion-resistance together with a long wearlife and high strength.
- 45-series, straight run and sideflex**
This chain is very suitable for glassworks and other dry (!), abrasive environments. Its material is based on through-hardened carbon steel. It offers an extremely high working load and superior wear-resistance.
- 60-series Star*, straight run and sideflex**
This chain is very suitable for heavy duty and high-speed applications such as pressureless inliners and similar applications requiring exceptionally smooth transfer of (unstable) products. This Star-material is a special chrome nickel stainless steel. It offers superior sliding properties, the longest wearlife and withstands the highest possible working load; 60-Series Star is absolutely the best chain on the market.



CASES ON WEAR-RESISTANT 60-SERIES MAGNETFLEX® CHAIN.

AND . . .

For most steel chains you can choose for standard, Slideline and/or MAX-line quality.

Slideline chains have very close tolerances with respect to flatness and surface finish. Together with the polished hinges, this makes Slideline chains the best choice for pressureless combiners/inliners and for other applications requiring smooth product transfer.

MAX-line chains offer maximum product support, due to maximum plate surface. For straight run chains this means that the gap between the links has been reduced from 2.8 mm to 1.6 mm. For sideflex chains this means that the sideflex radius has changed from 457 to 500 mm. This makes MAX-line chains the best choice for a reliable product flow.

STEEL SLATBAND CHAINS

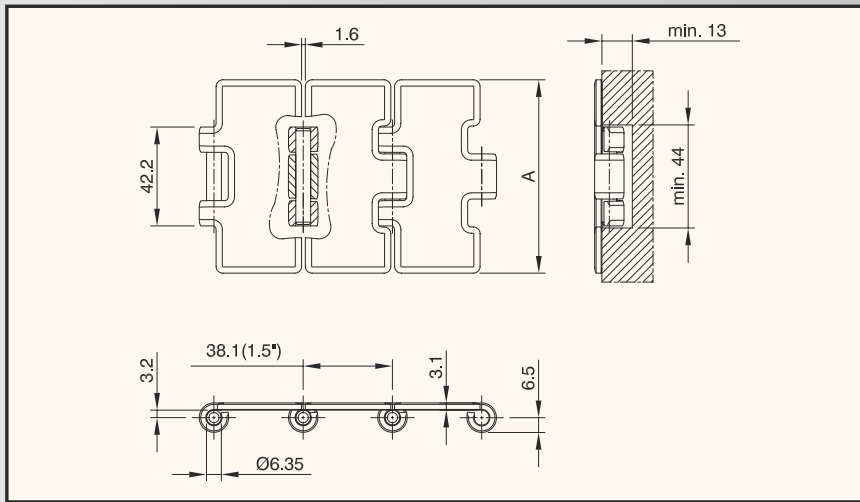

Quality	Chain type	Code nr.	Plate width		Working load (max.) N	Backflex radius (min.) mm	Surface finish (max.) μm	Flatness (max.) mm	Gap mm	Weight kg/m
			A mm	inch						
10-SERIES										
STANDARD	10 S 31	762.10.31	82.5	3.25	4950	75	0.60	+/- 0.12	2.8	2.55
SLIDELINE	10 S 31 S	762.12.31	82.5	3.25	4950	75	0.40	+/- 0.10	2.8	2.55
10-SERIES MAX-LINE										
STANDARD	10 S 31 M	762.13.31	82.5	3.25	4950	150	0.60	+/- 0.12	1.6	2.61
	10 S 42 M	762.13.42	114.3	4.50	4950	150	0.60	+/- 0.15	1.6	3.28
	10 S 72 M	762.13.72	190.5	7.50	4950	150	0.60	+/- 0.35	1.6	4.99
18-SERIES MAX-LINE										
STANDARD	18 S 31 M	762.83.31	82.5	3.25	4950	150	0.50	+/- 0.12	1.6	2.67
	18 S 42 M	762.83.42	114.3	4.50	4950	150	0.50	+/- 0.15	1.6	3.36
	18 S 72 M	762.83.72	190.5	7.50	4950	150	0.50	+/- 0.35	1.6	5.11
45-SERIES MAX-LINE										
STANDARD	45 S 31 M	762.43.31	82.5	3.25	8350	150	0.60	+/- 0.60	1.6	2.61
	45 S 42 M	762.43.42	114.3	4.50	8350	150	0.60	+/- 0.60	1.6	3.28
60-SERIES										
STANDARD	60 S 31	762.50.31	82.5	3.25	6000	75	0.50	+/- 0.12	2.8	2.55
SLIDELINE	60 S 31 S	762.62.31	82.5	3.25	6000	75	0.30	+/- 0.10	2.8	2.55
60-SERIES MAX-LINE										
STANDARD	60 S 22 M	762.53.22	63.5	2.50	6000	150	0.50	+/- 0.12	1.6	2.14
	60 S 25 M	762.53.25	66.7	2.63	6000	150	0.50	+/- 0.12	1.6	2.27
	60 S 23 M	762.53.23	69.9	2.75	6000	150	0.50	+/- 0.12	1.6	2.34
	60 S 30 M	762.53.30	76.2	3.00	6000	150	0.50	+/- 0.12	1.6	2.43
	60 S 31 M	762.53.31	82.5	3.25	6000	150	0.50	+/- 0.12	1.6	2.61
	60 S 32 M	762.53.32	88.9	3.50	6000	150	0.50	+/- 0.12	1.6	2.71
	60 S 42 M	762.53.42	114.3	4.50	6000	150	0.50	+/- 0.15	1.6	3.28
	60 S 60 M	762.53.60	152.4	6.00	6000	150	0.50	+/- 0.35	1.6	4.14
SLIDELINE	60 S 72 M	762.53.72	190.5	7.50	6000	150	0.50	+/- 0.35	1.6	4.99
	60 S 22 SM	762.69.22	63.5	2.50	6000	150	0.30	+/- 0.10	1.6	2.14
	60 S 31 SM	762.69.31	82.5	3.25	6000	150	0.30	+/- 0.10	1.6	2.61
	60 S 84 SM	762.69.84	83.8	3.30	6000	150	0.30	+/- 0.10	1.6	2.63
	60 S 32 SM	762.69.32	88.9	3.50	6000	150	0.30	+/- 0.10	1.6	2.71

Standard length: 3.048 m - 10 feet (80 links)

STEEL SLATBAND CHAINS

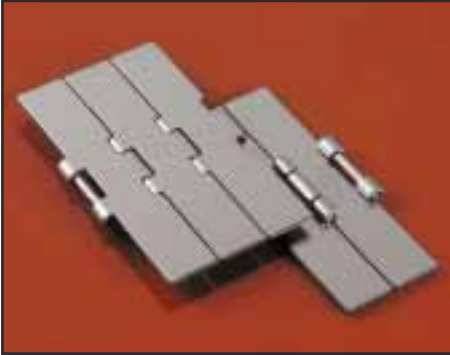

**STRAIGHT RUN
HEAVY DUTY
MAX-LINE**

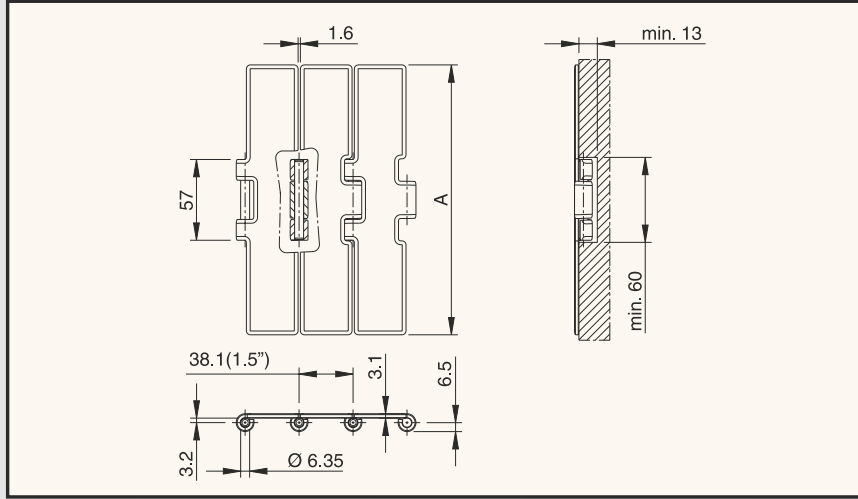

MATERIAL
page 158



page 118, 119

Quality	Chain type	Code nr.	Plate width		Working load (max.) N	Backflex radius (min.) mm	Surface finish (max.) μm	Flatness (max.) mm	Gap mm	Weight kg/m
			A mm	inch						
60-SERIES MAX-LINE										
STANDARD	60 S 75 M	762.53.75	190.5	7.50	7000	150	0.50	+/- 0.35	1.6	5.10

Standard length: 3.048 m - 10 feet (80 links)

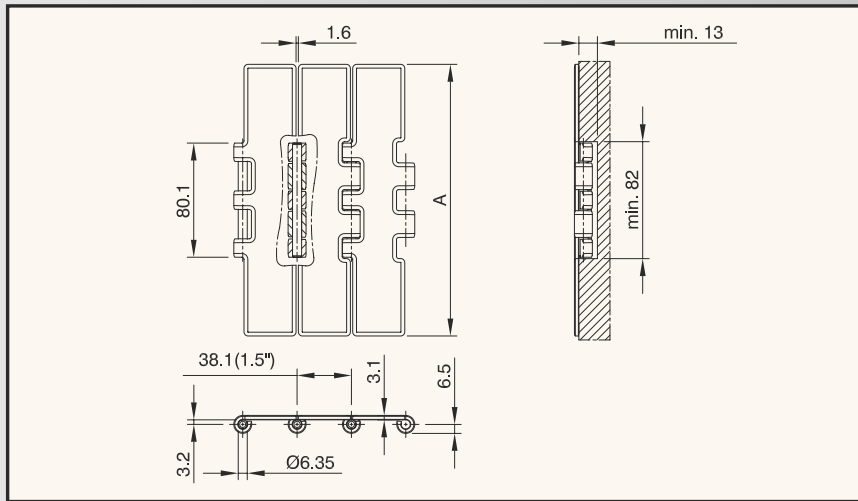

**STRAIGHT RUN
DOUBLE HINGE
MAX-LINE**



page 143

MATERIAL
page 158

page 115, 116

Quality	Chain type	Code nr.	Plate width		Working load (max.) N	Backflex radius (min.) mm	Surface finish (max.) μm	Flatness (max.) mm	Gap mm	Weight kg/m
			A mm	inch						
10-SERIES MAX-LINE										
STANDARD	10 S 77 M	762.13.77	190.5	7.50	7000	150	0.60	+/- 0.35	1.6	5.64
18-SERIES MAX-LINE										
STANDARD	18 S 77 M	762.83.77	190.5	7.50	7000	150	0.50	+/- 0.35	1.6	5.78
60-SERIES MAX-LINE										
STANDARD	60 S 77 M	762.53.77	190.5	7.50	9500	150	0.50	+/- 0.35	1.6	5.64

Standard length: 3.048 m - 10 feet (80 links)

STEEL SLATBAND CHAINS

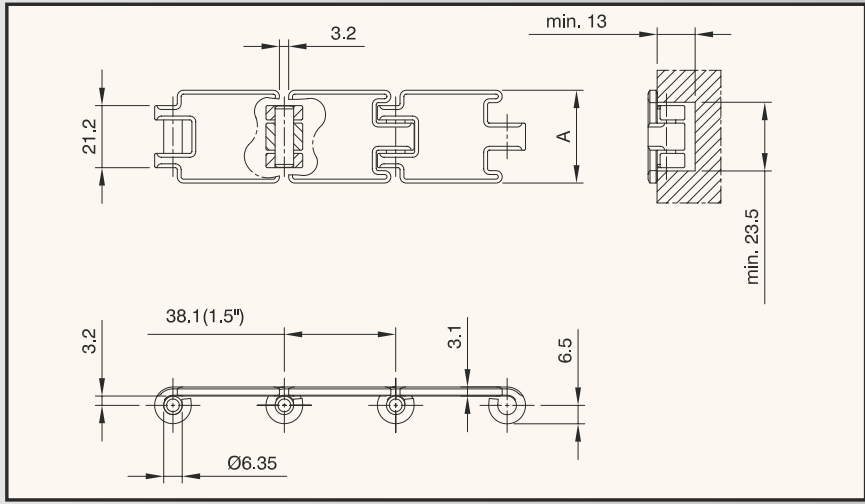

MATERIAL
page 158

page 111

Quality	Chain type	Code nr.	Plate width		Working load (max.) N	Backflex radius (min.) mm	Surface finish (max.) μm	Flatness (max.) mm	Gap mm	Weight kg/m
			A mm	inch						
60-SERIES										
STANDARD	60 S 11*	762.50.11	31.8	1.25	2500	75	0.50	+/- 0.12	3.2	1.07
	60 S 13**	762.50.13	44.5	1.75	2500	75	0.50	+/- 0.12	3.2	1.35



* Packaging: three strands of 3.048 m - 10 feet (3 x 80 links) per box

** Packaging: two strands of 3.048 m - 10 feet (2 x 80 links) per box

Standard length: 3.048 m - 10 feet (80 links)

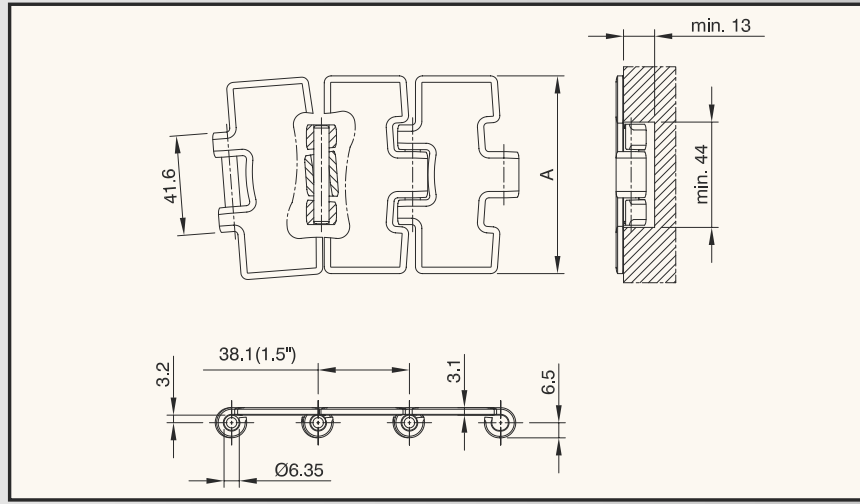
STEEL SLATBAND CHAINS



-  page 75
-  page 141, 142
- MATERIAL**
page 158
-  page 112-114

Quality	Chain type	Code nr.	Plate width		Working load (max.) N	Backflex radius (min.) mm	Surface finish (max.) μm	Flatness (max.) mm	Sideflex radius (min.) mm	Weight kg/m
			A mm	inch						
10-SERIES MAX-LINE										
STANDARD	10 M 31 M	767.13.31	82.5	3.25	4950	100	0.60	+/- 0.12	500	2.50
	10 M 42 M	767.13.42	114.3	4.50	4950	100	0.60	+/- 0.15	500	3.12
	10 M 72 M	767.13.72	190.5	7.50	4950	100	0.60	+/- 0.35	500	4.59
45-SERIES MAX-LINE										
STANDARD	45 M 31 M	767.43.31	82.5	3.25	8350	100	0.60	+/- 0.60	500	2.50
	45 M 42 M	767.43.42	114.3	4.50	8350	100	0.60	+/- 0.60	500	3.11
60-SERIES MAX-LINE										
STANDARD	60 M 31 M	767.53.31	82.5	3.25	6000	100	0.50	+/- 0.12	500	2.50
	60 M 42 M	767.53.42	114.3	4.50	6000	100	0.50	+/- 0.15	500	3.12
	60 M 72 M	767.53.72	190.5	7.50	6000	100	0.50	+/- 0.35	500	4.59
SLIDELINE	60 M 31 SM	767.69.31	82.5	3.25	6000	100	0.30	+/- 0.10	500	2.50
	60 M 84 SM	767.69.84	83.8	3.30	6000	100	0.30	+/- 0.10	500	2.52

Standard length: 3.048 m - 10 feet (80 links)

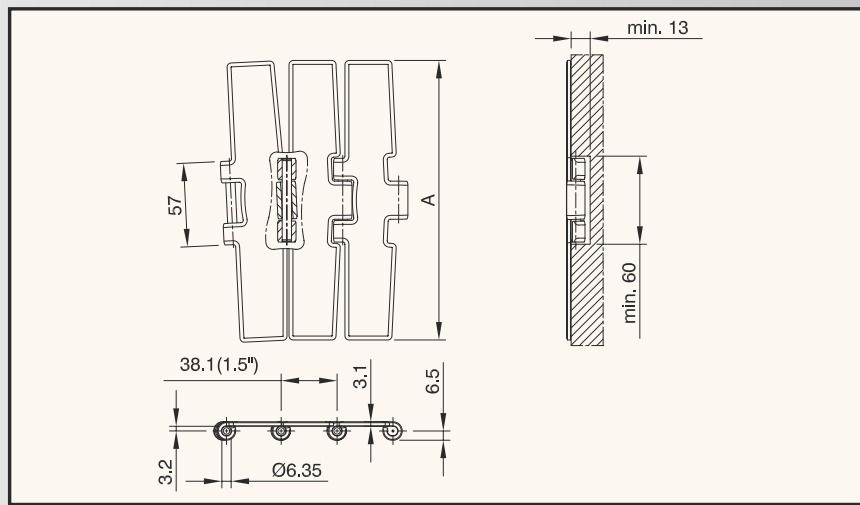

-  page 91, 92
- MATERIAL**
page 158
-  page 118, 119

Quality	Chain type	Code nr.	Plate width		Working load (max.) N	Backflex radius (min.) mm	Surface finish (max.) μm	Flatness (max.) mm	Sideflex radius (min.) mm	Weight kg/m
			A mm	inch						
60-SERIES MAX-LINE										
STANDARD	60 M 75 M	767.53.75	190.5	7.50	7000	100	0.50	+/- 0.35	860	5.03

Standard length: 3.048 m - 10 feet (80 links)

STEEL SLATBAND CHAINS



**SIDEFLEXING
MAX-LINE
TAB**

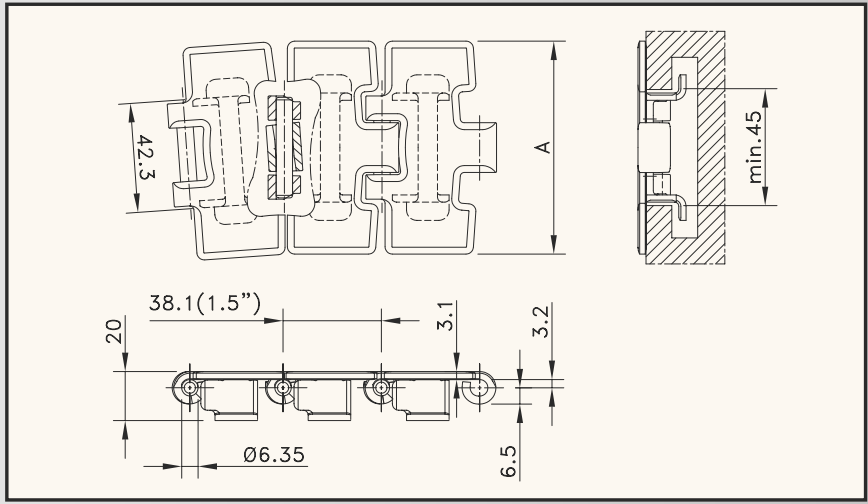

page 109

ask technical support

MATERIAL

page 158

ask technical support

Quality	Chain type	Code nr.	Plate width		Working load (max.) N	Backflex radius (min.) mm	Surface finish (max.) μm	Flatness (max.) mm	Sideflex radius (min.) mm	Weight kg/m
			A mm	inch						
60-SERIES MAX-LINE WITH TABS										
STANDARD	60 T 31 M	767.57.31	82.5	3.25	6000	100	0.50	+/- 0.12	500	3.10
	60 T 42 M	767.57.42	114.3	4.50	6000	100	0.50	+/- 0.15	500	3.80
	60 T 72 M	767.57.72	190.5	7.50	6000	100	0.50	+/- 0.35	500	5.50

Standard length: 3.048 m - 10 feet (80 links)



STEEL CHAINS WITH RUBBER TOP

The stainless steel slabband chain with rubber top is used for inclined and declined conveying of crates in heavy duty, abrasive conditions. The material used for these chains is 60-series Star, MCC's top of the range.



HEAVY DUTY CRATE CONVEYOR WITH STAINLESS STEEL CHAIN WITH RUBBER TOP.

BENEFITS

- Softline bevelling**
Quality finish in every detail.
- Long life vulcanized rubber top**
The material of the rubber guarantees a long wearlife.
- Excellent bonding of rubber top**
The special treatment guarantees super bonding.
- Inclines up to 20 degrees**
Adequate for most incline applications. The actual angle that can be used depends on product and circumstances. In case of doubts, please ask our Technical Support department.

PROGRAMME

- Straight run**
In 3¹/₄" and 7¹/₂" versions.
- Magnetflex®**
These sideflexing chains have no tabs.



CRATES ON INCLINING DOUBLE HINGE CHAIN WITH RUBBER TOP.

AND . . .

The 7¹/₂" heavy duty stainless steel chains are also available with a rubber top, ideal for further standardisation in your conveyor construction.

STEEL SLATBAND CHAINS WITH RUBBER TOP

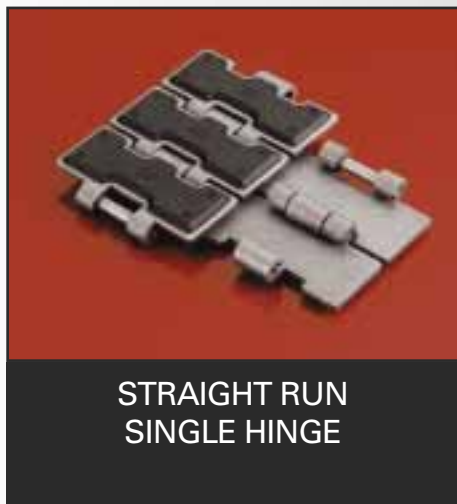

**STRAIGHT RUN
SINGLE HINGE**

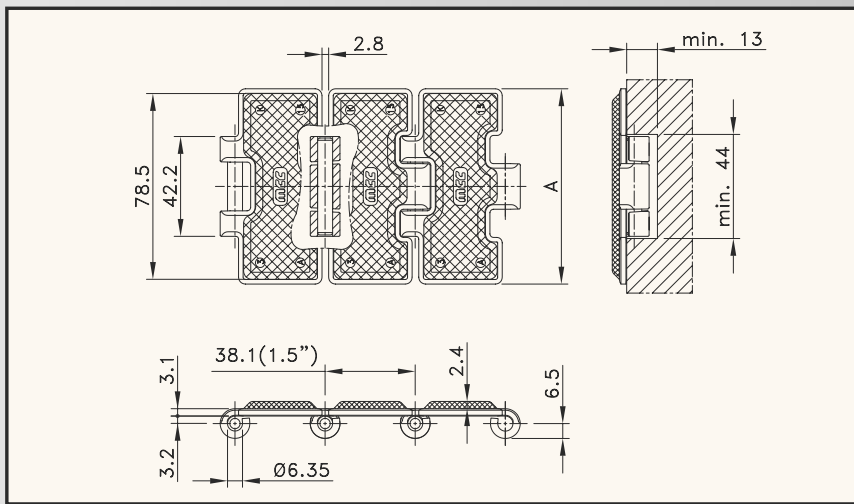

Quality	Chain type	Code nr.	Plate width		Working load (max.) N	Backflex radius (min.) mm	Surface finish (max.) μm	Flatness (max.) mm	Gap mm	Weight kg/m
			A mm	inch						
60-SERIES										
STANDARD	60 S 31 R	762.54.31	82.5	3.25	6000	75	0.50	+/- 0.12	2.8	2.55

Standard length: 3.048 m - 10 feet (80 links)

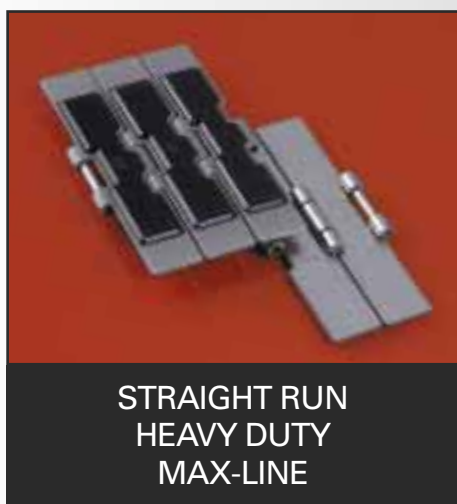

**STRAIGHT RUN
HEAVY DUTY
MAX-LINE**

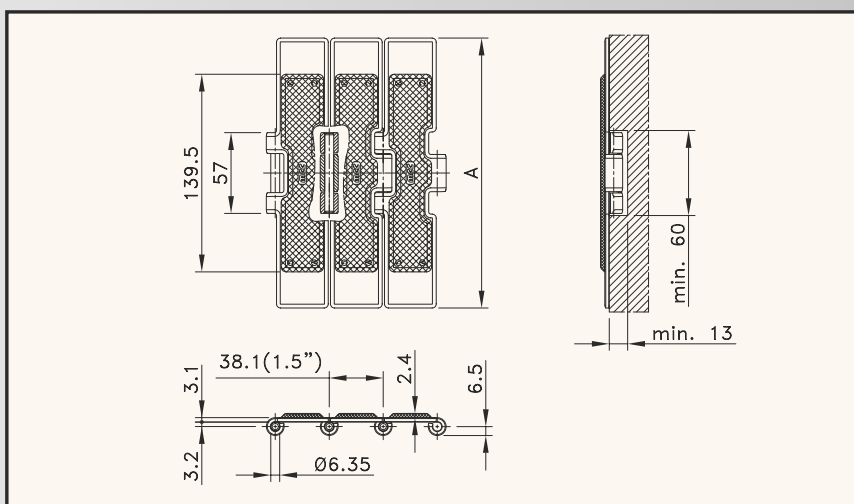

Quality	Chain type	Code nr.	Plate width		Working load (max.) N	Backflex radius (min.) mm	Surface finish (max.) μm	Flatness (max.) mm	Gap mm	Weight kg/m
			A mm	inch						
60-SERIES MAX-LINE										
STANDARD	60 S 75 RM	762.54.75	190.5	7.50	7000	150	0.50	+/- 0.35	1.6	5.21

Standard length: 3.048 m - 10 feet (80 links)

STEEL SLATBAND CHAINS WITH RUBBER TOP

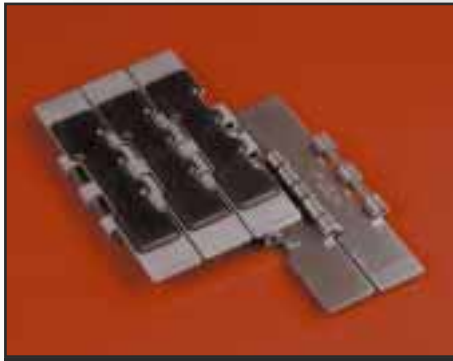

**STRAIGHT RUN
DOUBLE HINGE
MAX-LINE**

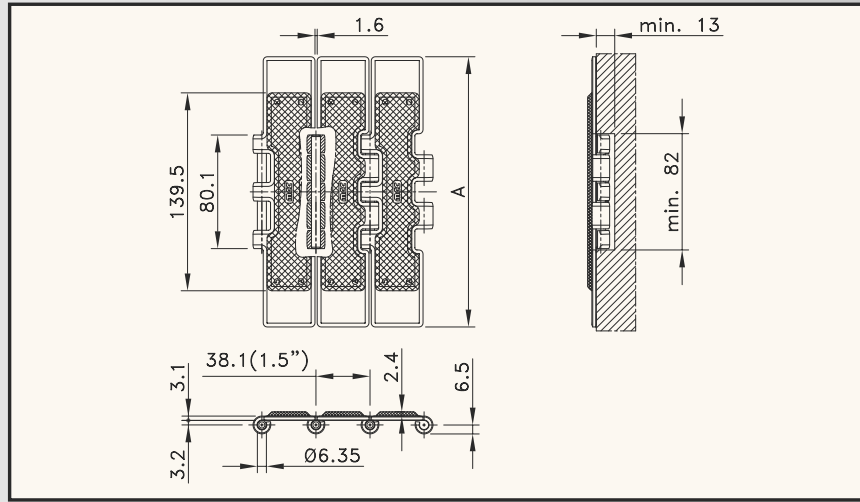

Quality	Chain type	Code nr.	Plate width		Working load (max.) N	Backflex radius (min.) mm	Surface finish (max.) μm	Flatness (max.) mm	Gap mm	Weight kg/m
			A mm	inch						
60-SERIES MAX-LINE										
STANDARD	60 S 77 RM	762.56.77	190.5	7.50	9500	150	0.50	+/- 0.35	1.6	5.64



Standard length: 3.048 m - 10 feet (80 links)

STEEL SLATBAND CHAINS WITH RUBBER TOP

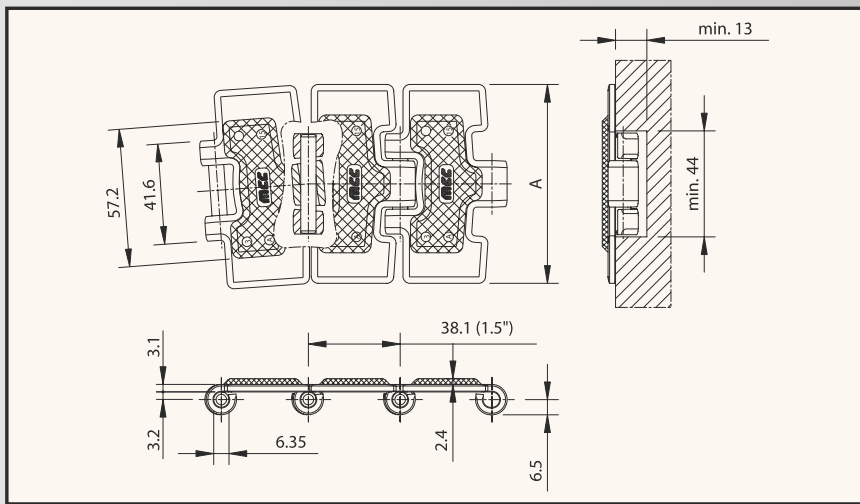

**MAGNETFLEX®
MAX-LINE**



-  page 75
-  page 141, 142
- MATERIAL**
page 158
-  page 112-114

Quality	Chain type	Code nr.	Plate width		Working load (max.) N	Backflex radius (min.) mm	Surface finish (max.) μm	Flatness (max.) mm	Sideflex radius (min.) mm	Weight kg/m
			A mm	inch						
60-SERIES MAX-LINE										
STANDARD	60 M 31 RM	767.56.31	82.5	3.25	6000	100	0.50	+/- 0.12	500	2.54
	60 M 72 RM	767.56.72	190.5	7.50	6000	100	0.50	+/- 0.35	500	4.70

Standard length: 3.048 m - 10 feet (80 links)



**HEAVY DUTY
MAGNETFLEX®
MAX-LINE**

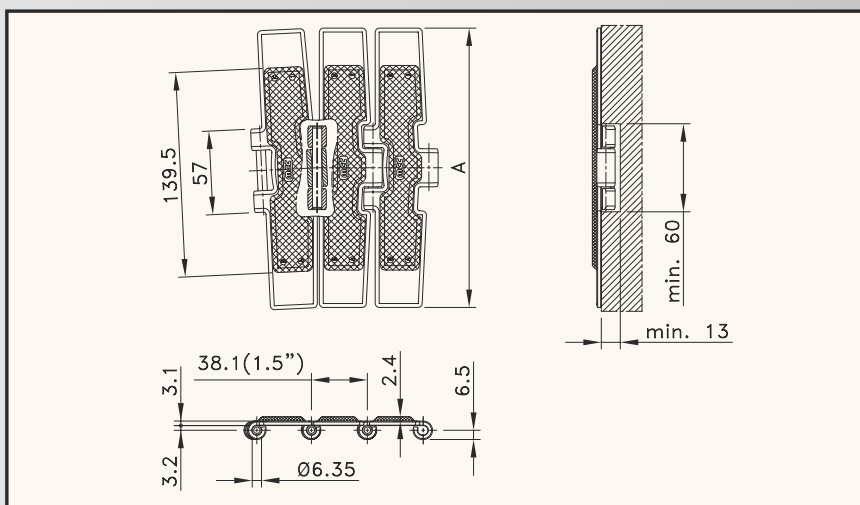

-  page 91, 92
- MATERIAL**
page 158
-  page 118,119

Quality	Chain type	Code nr.	Plate width		Working load (max.) N	Backflex radius (min.) mm	Surface finish (max.) μm	Flatness (max.) mm	Sideflex radius (min.) mm	Weight kg/m
			A mm	inch						
60-SERIES MAX-LINE										
STANDARD	60 M 75 RM	767.54.75	190.5	7.50	7000	100	0.50	+/- 0.35	860	5.14

Standard length: 3.048 m - 10 feet (80 links)

MCC PLASTIC SLATBAND CHAINS

The plastic slatband chain meets the rigorous demands of container handling. These chains are often used for conveying cans, cartons, trays, shrink-wrapped products, glass, PET and petaloid bottles and other plastic containers.



HIGH-SPEED, HIGH-CAPACITY CAN CONVEYOR WITH PLASTIC MAGNETFLEX® CHAIN.

BENEFITS

- Optimum product handling**
This is due to the softline bevelling, exceptionally flat surface and special XL-polyacetal.
- Long wearlife**
The XL-material offers an extended wearlife with continuously low friction.
- High working load**
Excellent moulding ensures high strength.

PROGRAMME

- Straight run**
Available in single hinge (SH), single hinge with thick top plate (SHD), double hinge (SWH) and Heavy Duty Straight (HDS).
- Magnetflex® without tabs**
These sideflexing chains are available in standard radius hinge Magnetflex® (RHM), standard radius hinge Magnetflex® with thick top plate (RHMD) and heavy duty Magnetflex® (HDFM).
These products are patented in a large number of countries.
- Sideflex with tabs**
Obtainable in standard radius hinge chain (RH), standard radius hinge with thick top plate (RHD), heavy duty flex (HDF) and small radius hinge (SRH).



PET BOTTLES ON SOFTLINE BEVELLED SINGLE HINGE CHAIN.

AND . . .

Most MCC plastic chains are moulded in special light brown XL (extra low friction)-polyacetal, which is different from other existing materials. It contains special lubricants in its molecular structure, ensuring consistent performance and reduced wear throughout the wearlife of the chain. For improved chemical resistance, MCC has white CRS chains in the programme. The XS-material stands for a state-of-the-art polyacetal, giving a much longer life, high PV limits and a continuous low friction. Some chain types are also available in black AS (anti static)-material, polyacetal with improved electrical conductive properties, reducing the build-up of static electricity. The chains with a thick top plate (4.8 instead of 4.0 mm) offer a 40% longer wearlife.

PLASTIC SLATBAND CHAINS



**STRAIGHT RUN
SINGLE HINGE**

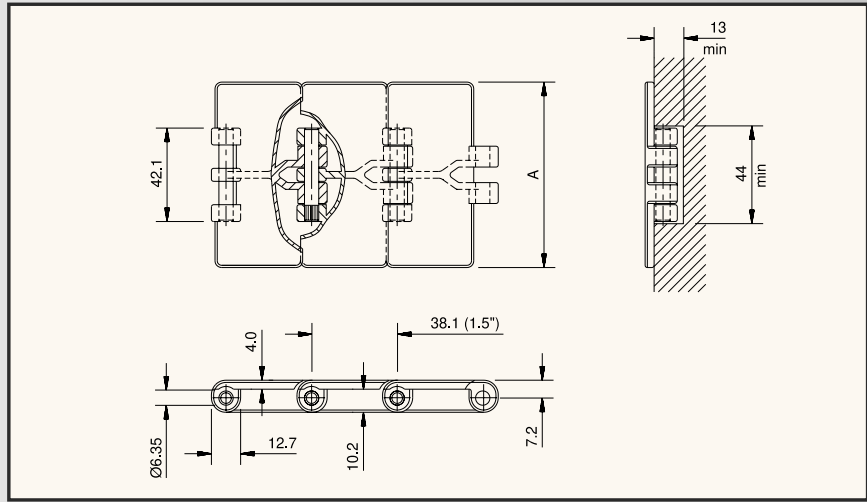

Chain type	Code nr.	Plate width		Working load (max.) N (21°C)	Backflex radius (min.)	Plate thickness	Weight
		mm	inch				
XL-MATERIAL							
SH 250 XL	750.42.22	63.5	2.50	1230	50	4.0	0.69
SH 325 XL	750.42.31	82.5	3.25	1230	50	4.0	0.82
SH 84 XL	750.42.35	83.8	3.30	1230	50	4.0	0.82
SH 350 XL	750.42.32	88.9	3.50	1230	50	4.0	0.87
SH 400 XL	750.42.40	101.6	4.00	1230	50	4.0	0.95
SH 450 XL	750.42.42	114.3	4.50	1230	50	4.0	1.00
SH 600 XL	750.42.60	152.4	6.00	1230	50	4.0	1.20
SH 750 XL	750.42.72	190.5	7.50	1230	50	4.0	1.44
XS-MATERIAL							
SH 325 XS	750.10.31	82.5	3.25	1230	50	4.0	0.82
CRS-MATERIAL - WITH IMPROVED CHEMICAL RESISTANCE							
SH 325 CRS	750.56.31	82.5	3.25	800	50	4.0	0.82
AS-MATERIAL - ANTI STATIC							
SH 325 AS	750.47.31	82.5	3.25	740	50	4.0	0.82

Standard length: 3.048 m - 10 feet (80 links)



**STRAIGHT RUN
SINGLE HINGE
WITH THICK TOP PLATE**

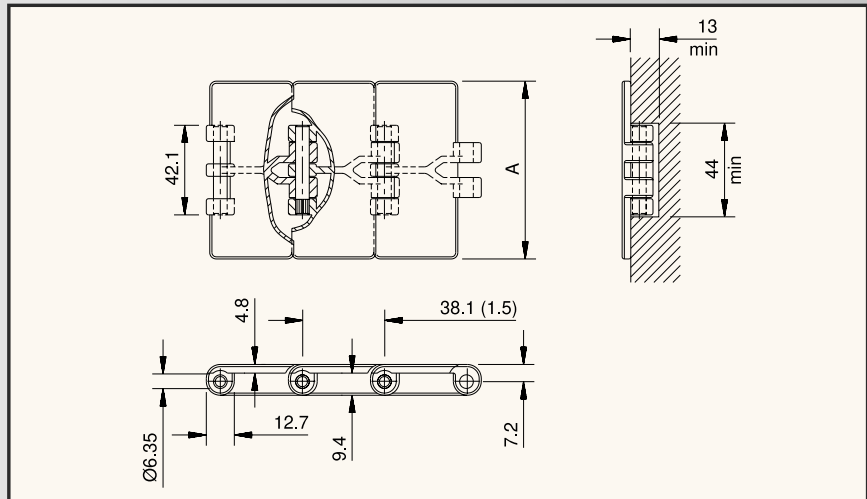

Chain type	Code nr.	Plate width		Working load (max.) N (21°C)	Backflex radius (min.)	Plate thickness	Weight
		mm	inch				
XL-MATERIAL							
SHD 325 XL	750.92.31	82.5	3.25	1230	50	4.8	0.87
SHD 450 XL	750.92.42	114.3	4.50	1230	50	4.8	1.06
SHD 750 XL	750.92.72	190.5	7.50	1230	50	4.8	1.53

Standard length: 3.048 m - 10 feet (80 links)

PLASTIC SLATBAND CHAINS



**STRAIGHT RUN
DOUBLE HINGE**

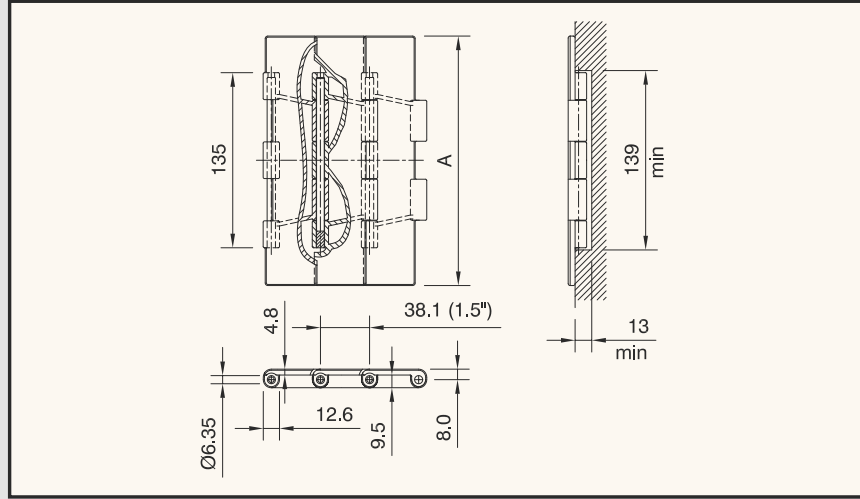

Chain type	Code nr.	Plate width		Working load (max.) N (21°C)	Backflex radius (min.) mm	Plate thickness mm	Weight kg/m
		A mm	inch				
XL-MATERIAL							
SWH 750 XL	750.72.77	190.5	7.50	2680	50	4.8	2.48
SWH 1000 XL	750.72.91	254.0	10.00	2680	50	4.8	2.82
SWH 1200 XL	750.72.92	304.8	12.00	2680	50	4.8	3.12

Standard length: 3.048 m - 10 feet (80 links)



**STRAIGHT RUN
HEAVY DUTY**

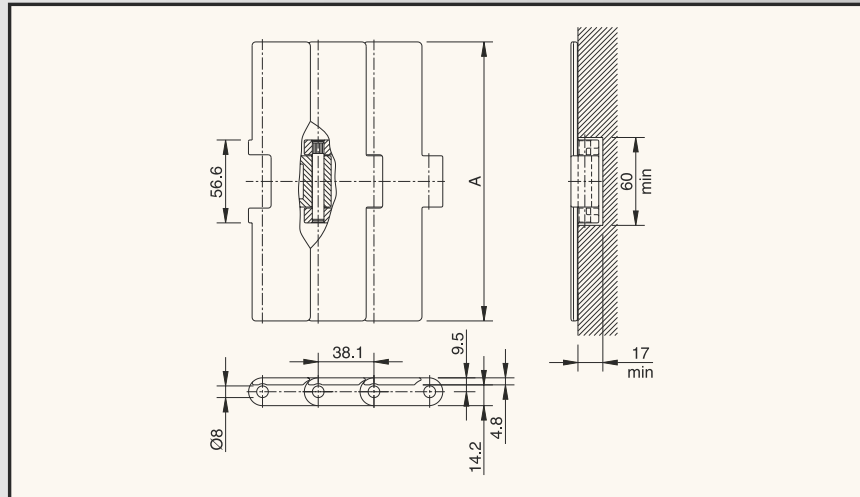

Chain type	Code nr.	Plate width		Working load (max.) N (21°C)	Backflex radius (min.) mm	Plate thickness mm	Weight kg/m
		A mm	inch				
XL-MATERIAL							
HDS 750 XL	752.62.72	190.5	7.50	3830	50	4.8	2.16
HDS 1000 XL	752.62.90	254.0	10.00	3830	50	4.8	2.42
HDS 1200 XL	752.62.92	304.8	12.00	3830	50	4.8	2.69

Standard length: 3.048 m - 10 feet (80 links)

PLASTIC SLATBAND CHAINS

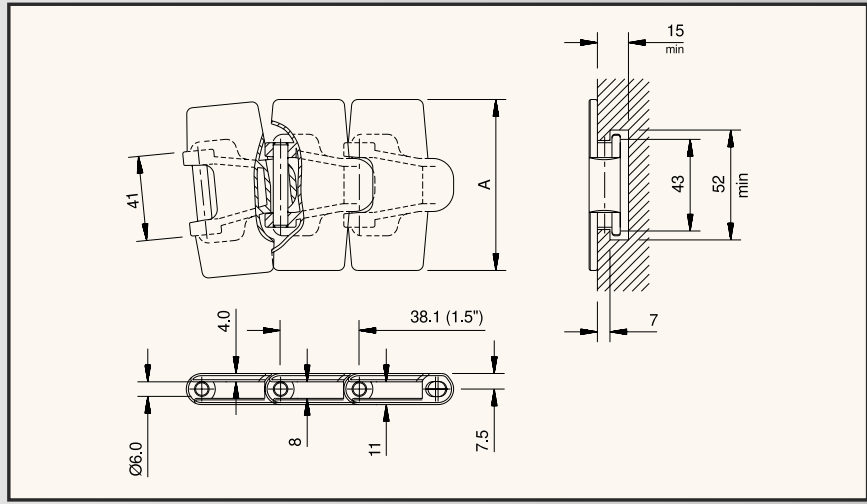

Chain type	Code nr.	Plate width		Working load (max.) N (21°C)	Backflex radius (min.) mm	Sideflex radius (min.) mm	Plate thickness mm	Weight kg/m
		A						
		mm	inch					
XL-MATERIAL								
SRH 325 XL	751.12.31	82.5	3.25	1780	50	200	4.0	0.87

Standard length: 3.048 m - 10 feet (80 links)

PLASTIC SLATBAND CHAINS

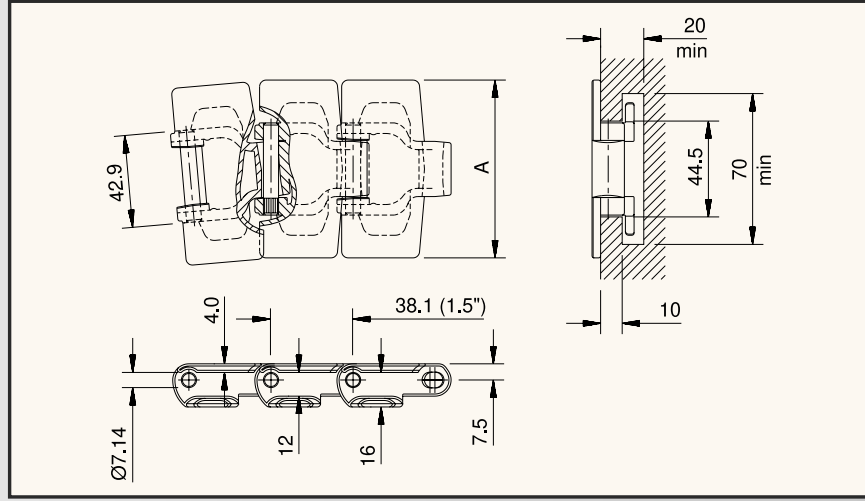

page 109

page 145

MATERIAL
page 158

122, 123, 125

Chain type	Code nr.	Plate width		Working load (max.) N (21°C)	Backflex radius (min.) mm	Sideflex radius (min.) mm	Plate thickness mm	Weight kg/m
		A mm	inch					
XL-MATERIAL								
RH 325 XL	751.42.31	82.5	3.25	2100	50	457	4.0	1.15
RH 450 XL	751.42.42	114.3	4.50	2100	50	457	4.0	1.30
AS-MATERIAL - ANTI STATIC								
RH 325 AS	751.47.31	82.5	3.25	1260	50	457	4.0	1.15

Standard length: 3.048 m - 10 feet (80 links)

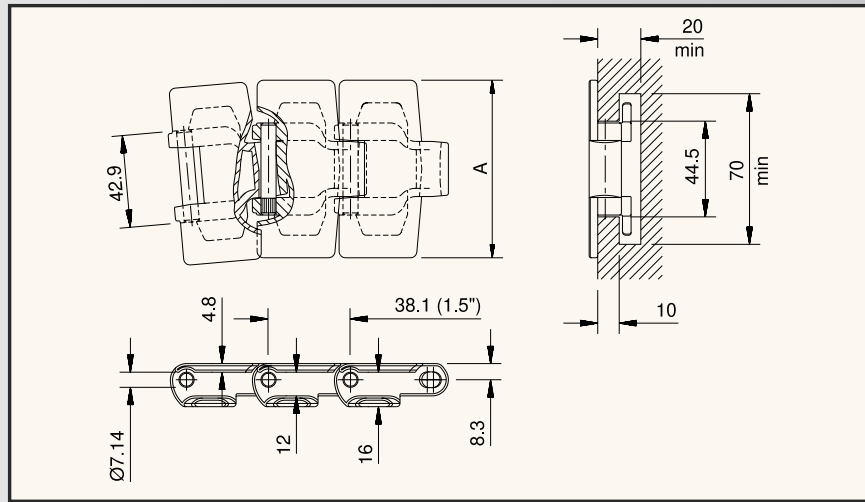

page 109

page 145

MATERIAL
page 158

122, 123, 125

Chain type	Code nr.	Plate width		Working load (max.) N (21°C)	Backflex radius (min.) mm	Sideflex radius (min.) mm	Plate thickness mm	Weight kg/m
		A mm	inch					
XL-MATERIAL								
RHD 325 XL	751.62.31	82.5	3.25	2100	50	457	4.8	1.20
RHD 450 XL	751.62.42	114.3	4.50	2100	50	457	4.8	1.38

Standard length: 3.048 m - 10 feet (80 links)

PLASTIC SLATBAND CHAINS

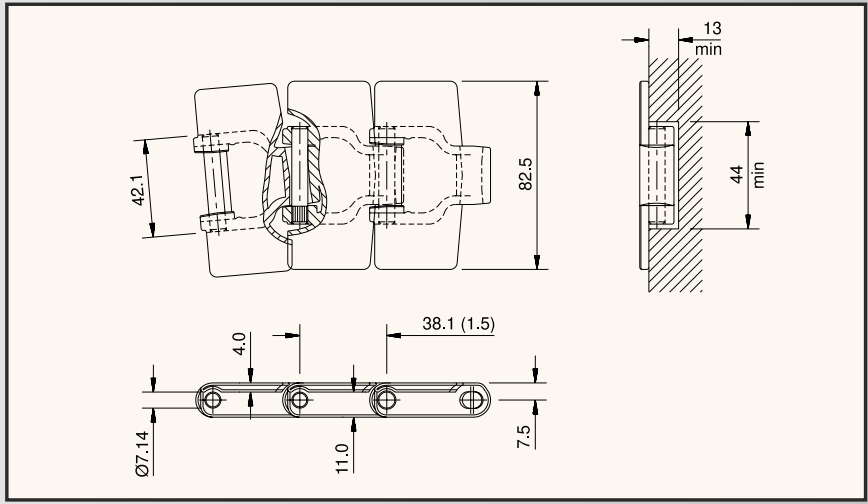

page 75

page 142, 145

MATERIAL
page 158

114, 122, 123

Chain type	Code nr.	Plate width		Working load (max.) N (21°C)	Backflex radius (min.) mm	Sideflex radius (min.) mm	Plate thickness mm	Weight kg/m
		A						
		mm	inch					
XL-MATERIAL								
RHM 325 XL	781.12.31	82.5	3.25	2100	50	457	4.0	1.03
RHM 84 XL	781.12.35	83.8	3.30	2100	50	457	4.0	1.03
RHM 450 XL	781.12.42	114.3	4.50	2100	50	457	4.0	1.16
XS-MATERIAL								
RHM 325 XS	781.30.31	82.5	3.25	2100	50	457	4.0	1.03
AS-MATERIAL - ANTI STATIC								
RHM 325 AS	781.17.31	82.5	3.25	1260	50	457	4.0	1.03

Standard length: 3.048 m - 10 feet (80 links)

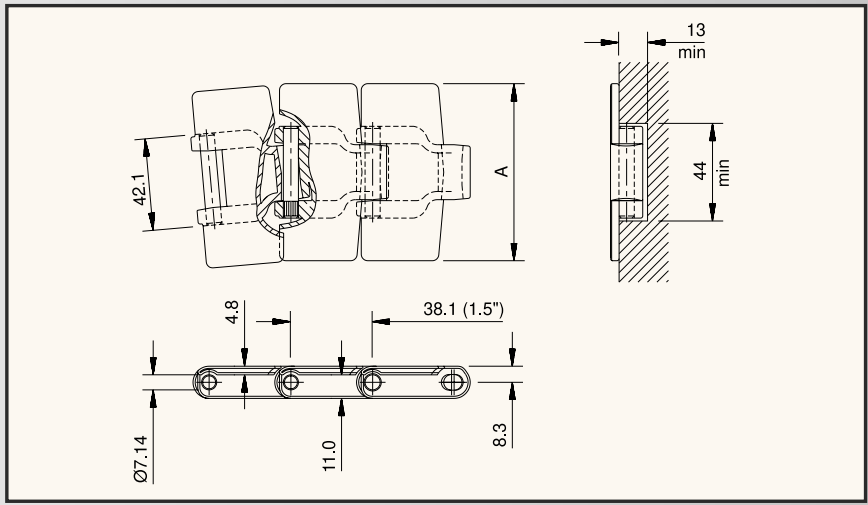

page 75

page 142, 145

MATERIAL
page 158

114, 122, 123

Chain type	Code nr.	Plate width		Working load (max.) N (21°C)	Backflex radius (min.) mm	Sideflex radius (min.) mm	Plate thickness mm	Weight kg/m
		A						
		mm	inch					
XL-MATERIAL								
RHMD 325 XL	781.22.31	82.5	3.25	2100	50	457	4.8	1.08
RHMD 450 XL	781.22.42	114.3	4.50	2100	50	457	4.8	1.26

Standard length: 3.048 m - 10 feet (80 links)

PLASTIC SLATBAND CHAINS

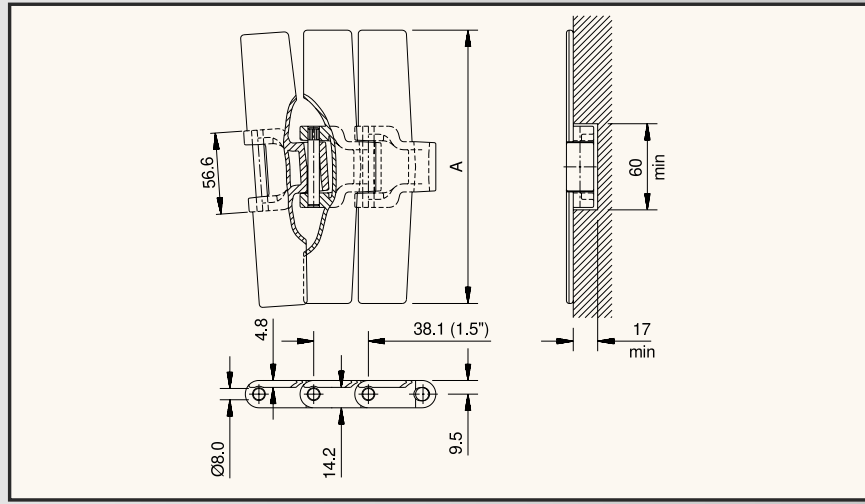

Chain type	Code nr.	Plate width		Working load (max.) N (21°C)	Backflex radius (min.) mm	Sideflex radius (min.) mm	Plate thickness mm	Weight kg/m
		A mm	inch					
XL-MATERIAL								
HDFM 750 XL	751.32.72	190.5	7.50	3830	50	610	4.8	2.16
HDFM 1000 XL	751.32.90	254.0	10.00	3830	50	610	4.8	2.42
HDFM 1200 XL	751.32.92	304.8	12.00	3830	50	610	4.8	2.69

Standard length: 3.048 m - 10 feet (80 links)

PLASTIC SLATBAND CHAINS

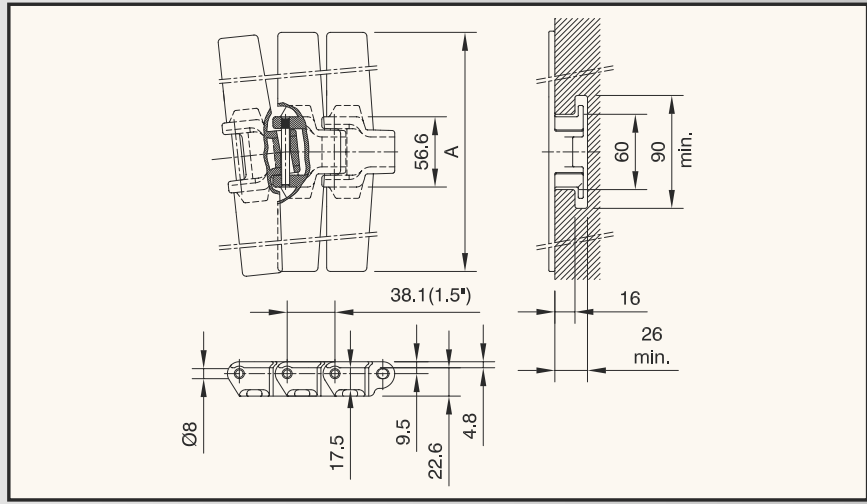

Chain type	Code nr.	Plate width		Working load (max.) N (21°C)	Backflex radius (min.) mm	Sideflex radius (min.) mm	Plate thickness mm	Weight kg/m	
		A							
		mm	inch						
XL-MATERIAL									
HDF 450 XL	751.82.42	114.3	4.50	3830	50	610	4.8	1.96	
HDF 750 XL	751.82.72	190.5	7.50	3830	50	610	4.8	2.38	
HDF 1000 XL	751.82.90	254.0	10.00	3830	50	610	4.8	2.69	
HDF 1200 XL	751.82.92	304.8	12.00	3830	50	610	4.8	2.94	

Standard length: 3.048 m - 10 feet (80 links)

The plastic Low Backline Pressure slatband chain will reduce backline pressure and noise. These chains are suitable for smooth and careful handling of a variety of multipack cans, like 4-and 6-packs, boxes, shrink-wrapped petaloid bottles and many more applications.



SMOOTH MULTI-PACK CONVEYOR WITH PLASTIC LBP CHAIN.

BENEFITS

- Low backline pressure**
The combination of pin and roller design and material gives the lowest possible backline pressure, 25 to 50% less than other LBP chains.
- Low noise**
The material and design of the accumulation rollers guarantee quiet operation.
- Optimum product stability**
Special design and precise roller pitch result in great product support.
- Long wearlife**
The material and design guarantee a long wearlife with a lasting low friction.

PROGRAMME

- Straight run**
Available in single hinge with thick top plate (SHD), double hinge (SWH) and Heavy Duty Straight (HDS).
- Magnetflex® without tabs**
These sideflexing chains are available in standard radius single hinge Magnetflex® with thick top plate (RHMD) and heavy duty Magnetflex® (HDFM).
- Sideflex with tabs**
Obtainable as heavy duty flex (HDF).



BOXES HANDLED WITH CARE ON QUIET 7.5" LBP CHAIN.

AND . . .

The MCC plastic LBP chains are moulded in anthracite, extra low friction XLA-polyacetal. The rollers are made of aubergine, special wear-resistant and sound-absorbing plastic. Rexnord offers the widest range of LBP chains available in the market.

PLASTIC SLATBAND LBP CHAINS

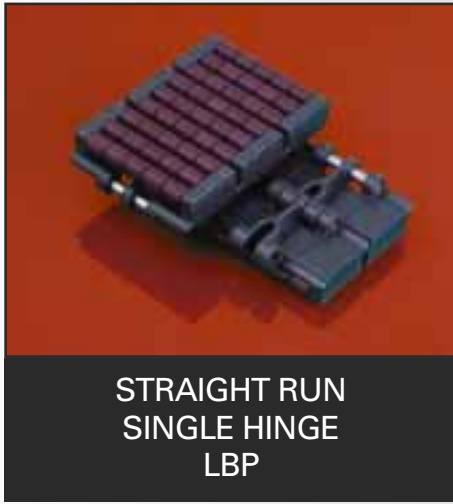

**STRAIGHT RUN
SINGLE HINGE
LBP**

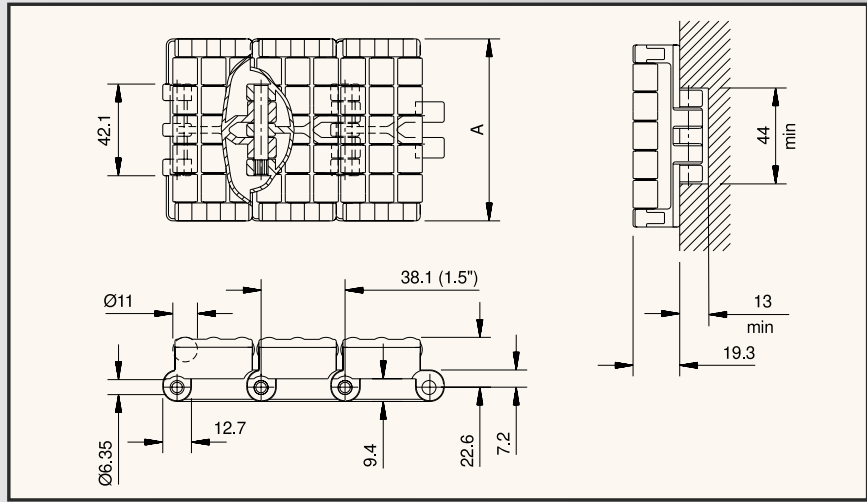

Chain type	Code nr.	Plate width		Working load (max.) N (21°C)	Backflex radius (min.) mm	Plate thickness mm	Weight kg/m
		A mm	inch				
SHD 325 LBP	752.85.09	82.5	3.25	1230	400	4.8	2.20

Standard length: 1.524 m - 5 feet (40 links)

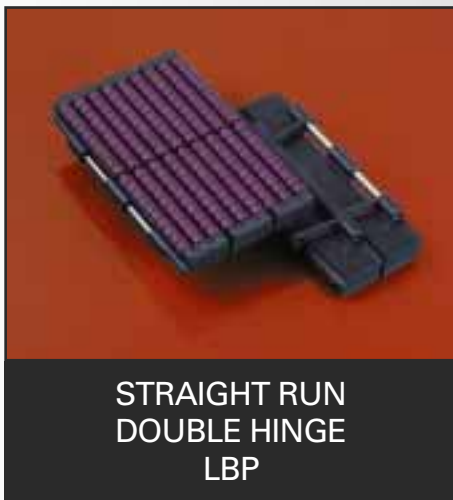

**STRAIGHT RUN
DOUBLE HINGE
LBP**

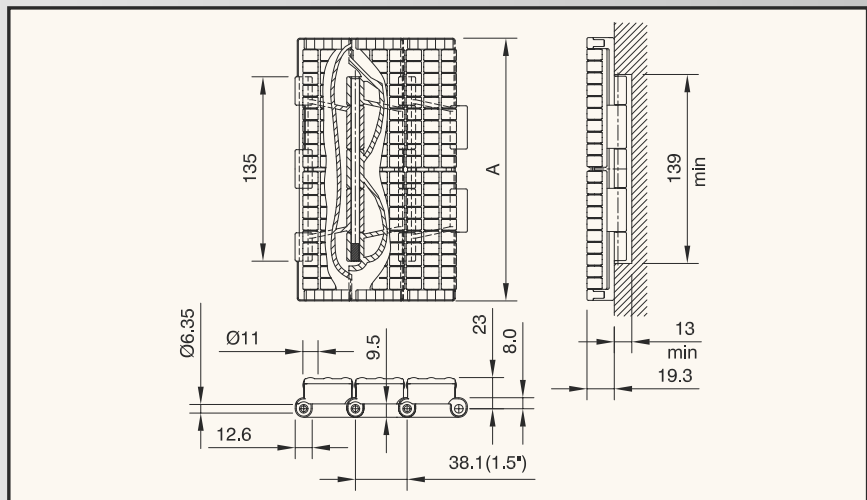

Chain type	Code nr.	Plate width		Working load (max.) N (21°C)	Backflex radius (min.) mm	Plate thickness mm	Weight kg/m
		A mm	inch				
SWH 750 LBP	752.82.09	190.5	7.50	2680	400	4.8	5.30
SWH 1000 LBP	752.82.11	254.0	10.00	2680	400	4.8	6.60
SWH 1200 LBP	752.82.10	304.8	12.00	2680	400	4.8	7.85

Standard length: 1.524 m - 5 feet (40 links)

PLASTIC SLATBAND LBP CHAINS

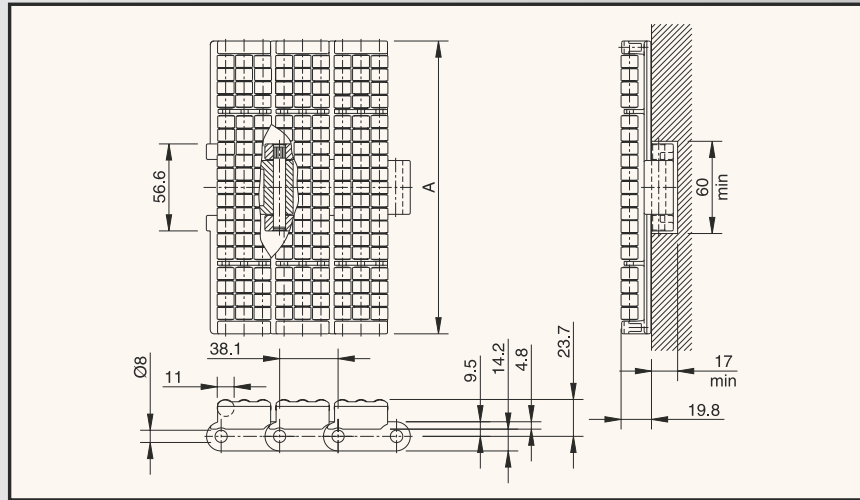



Chain type	Code nr.	Plate width		Working load (max.) N (21°C)	Backflex radius (min.) mm	Plate thickness mm	Weight kg/m
		A					
		mm	inch				
HDS 750 LBP	752.81.13	190.5	7.50	3830	400	4.8	4.28
HDS 1000 LBP	752.81.19	254.0	10.00	3830	400	4.8	5.23
HDS 1200 LBP	752.81.20	304.8	12.00	3830	400	4.8	5.83

Standard length: 1.524 m - 5 feet (40 links)

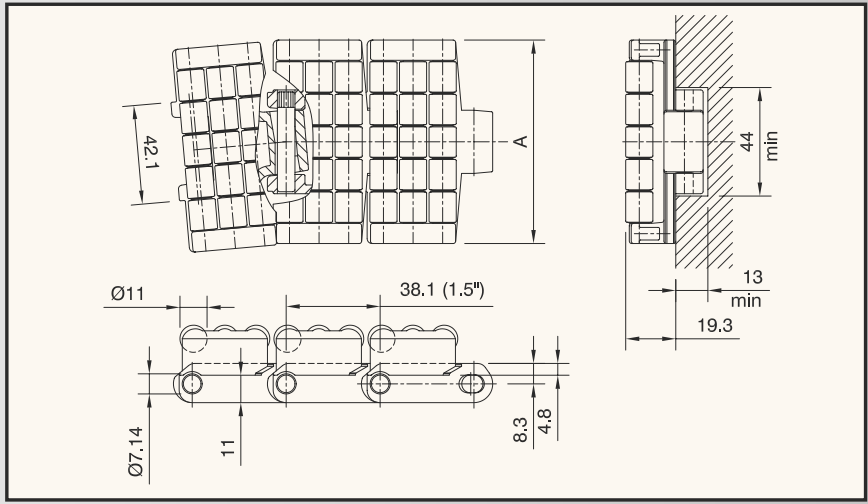
PLASTIC SLATBAND LBP CHAINS



-  page 95
-  page 142, 145
- MATERIAL**
page 158
-  114, 122, 123

Chain type	Code nr.	Plate width A		Working load (max.) N (21°C)	Backflex radius (min.) mm	Sideflex radius (min.) mm	Plate thickness mm	Weight kg/m
		mm	inch					
RHMD 325 LBP	752.87.09	82.5	3.25	2100	400	500	4.8	2.29

Standard length: 1.524 m - 5 feet (40 links)

PLASTIC SLATBAND LBP CHAINS

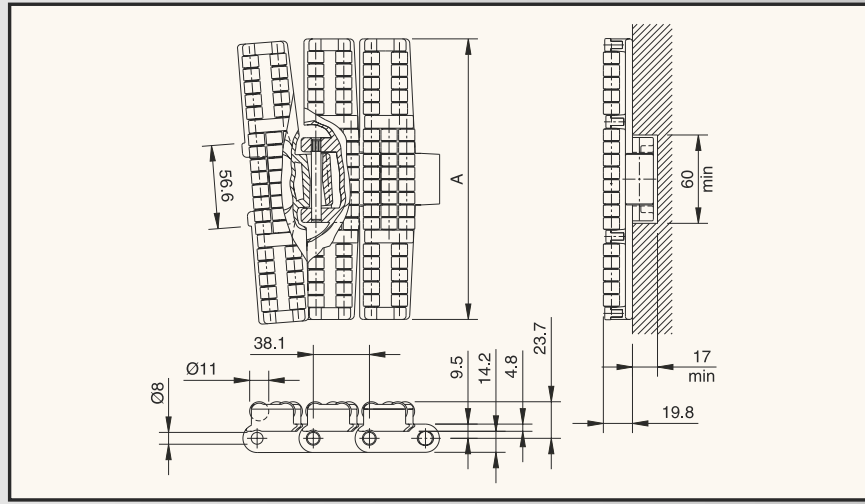

Chain type	Code nr.	Plate width		Working load (max.) N (21°C)	Backflex radius (min.) mm	Sideflex radius (min.) mm	Plate thickness mm	Weight kg/m
		A	A					
		mm	inch					
HDFM 750 LBP	752.88.13	190.5	7.50	3830	400	610	4.8	4.28
HDFM 1000 LBP	752.88.19	254.0	10.00	3830	400	610	4.8	5.23
HDFM 1200 LBP	752.88.20	304.8	12.00	3830	400	680	4.8	5.83

Standard length: 1.524 m - 5 feet (40 links)

PLASTIC SLATBAND LBP CHAINS

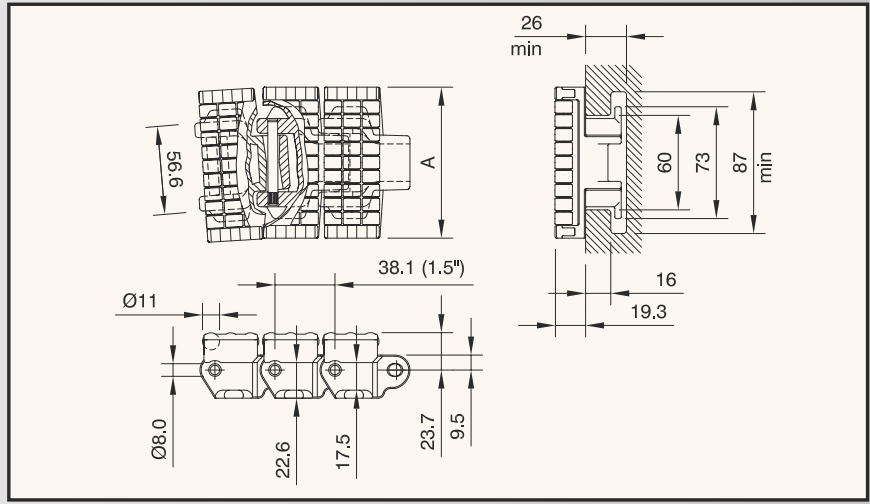
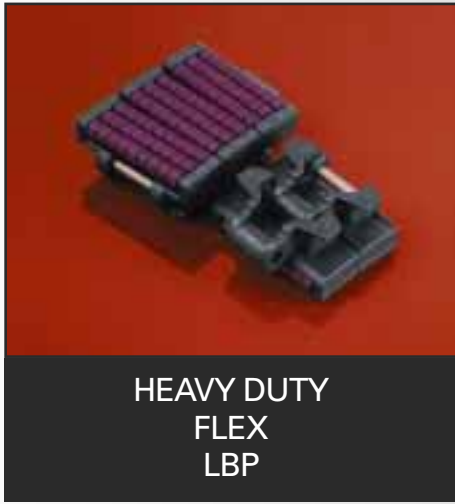

Chain type	Code nr.	Plate width A		Working load (max.) N (21°C)	Backflex radius (min.) mm	Sideflex radius (min.) mm	Plate thickness mm	Weight kg/m
		mm	inch					
HDF 375 LBP	752.89.09	95.3	3.75	3830	400	667	4.8	3.30

Standard length: 1.524 m - 5 feet (40 links)

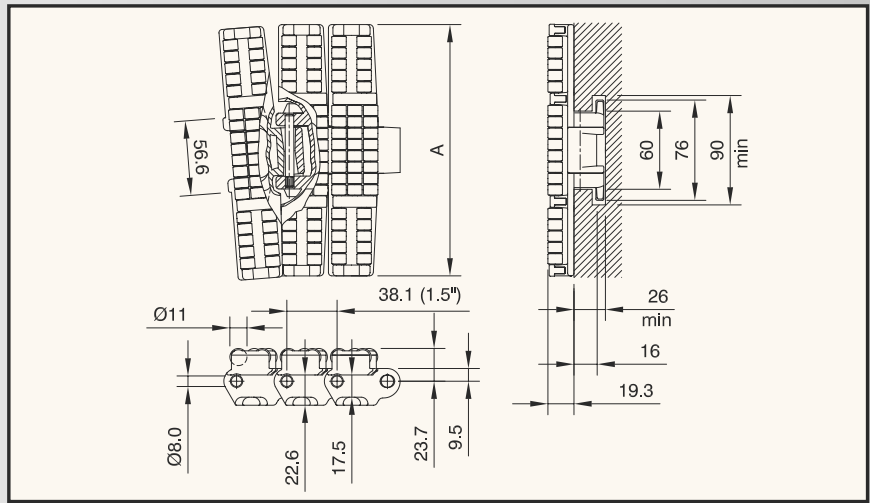

Chain type	Code nr.	Plate width A		Working load (max.) N (21°C)	Backflex radius (min.) mm	Sideflex radius (min.) mm	Plate thickness mm	Weight kg/m
		mm	inch					
HDF 750 LBP	752.89.13	190.5	7.50	3830	400	610	4.8	4.50
HDF 1000 LBP	752.89.19	254.0	10.00	3830	400	610	4.8	5.71
HDF 1200 LBP	752.89.20	304.8	12.00	3830	400	680	4.8	6.38

Standard length: 1.524 m - 5 feet (40 links)

mcc PLASTIC SUPERGRIP CHAINS

The *SuperGrip chain* is a plastic slatband chain with a moulded-in rubber top. SuperGrip chains are ideal for inclined and declined conveyors for small packs such as cardboard trays, boxes, 6-packs and shrink-wrapped packages.



INCLINED BOX CONVEYOR WITH PLASTIC SUPERGRIP CHAIN.

BENEFITS

- Maximum grip**
Pad design and material choice ensure high friction between product and chain.
- Optimum chain support in the return part**
Well positioned flat areas for return rollers make the construction easy.
- 100% secure bonding**
The state-of-the-art moulding process guarantees chemical and mechanical bonding of the rubber in the link.
- Long-life rubber top**
Shape and material stand for long life.
- Inclines up to 20 degrees**
Adequate for most applications. If you are in doubt, ask our Technical Support.

PROGRAMME

- Straight Run**
Available as double hinge (SWH) and Heavy Duty Straight (HDS).
- Magnetflex®**
These sideflexing chains have no tabs; they are obtainable as heavy duty Magnetflex® (HDFM) in various plate widths.



TRAYS WITH CANS ON HIGH FRICTION 12" SUPERGRIP CHAIN.

AND . . .

The material of the links is anthracite, wear resistant polybutylen-terephthalat; the top is made of special aubergine rubber.

PLASTIC SUPERGRIP CHAINS

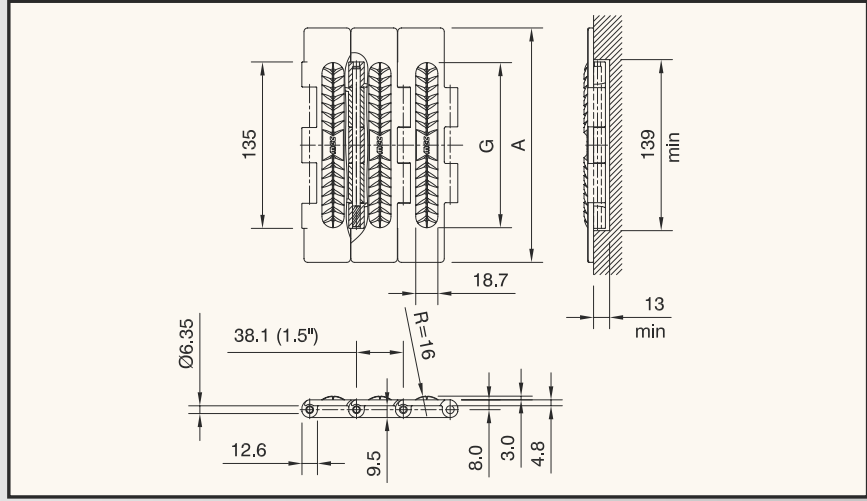

Chain type	Code nr.	Plate width		Working load (max.) N (21°C)	Backflex radius (min.) mm	Plate thickness mm	Weight kg/m
		A					
		mm	inch				
SWH 750 SG	780.11.77	190.5	7.50	2680	50	4.8	2.29
SWH 1000 SG	780.11.90	254.0	10.00	2680	50	4.8	2.67
SWH 1200 SG	780.11.92	304.8	12.00	2680	50	4.8	3.06

Standard length: 3.048 m - 10 feet (80 links)

The width (G) of the moulded-in rubber top varies per chain type:
134, 192.1 and 252.5 mm for respectively SWH 750 SG, SWH 1000 SG and SWH 1200 SG.

PLASTIC SUPERGRIP CHAINS



**STRAIGHT RUN
HEAVY DUTY
SUPERGRIP**

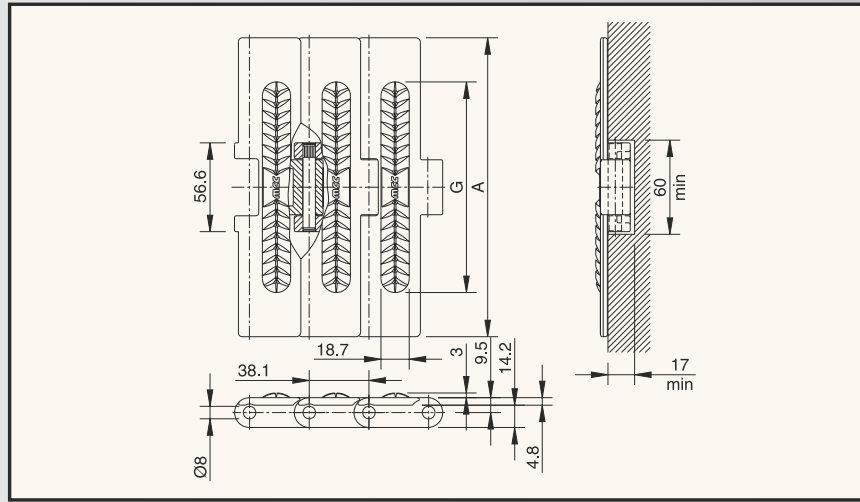

Chain type	Code nr.	Plate width		Working load (max.) N (21°C)	Backflex radius (min.) mm	Plate thickness mm	Weight kg/m
		A					
		mm	inch				
HDS 450 SG	780.31.42	114.3	4.50	2700	50	4.8	1.70
HDS 750 SG	780.31.72	190.5	7.50	2700	50	4.8	2.10
HDS 1000 SG	780.31.90	254.0	10.00	2700	50	4.8	2.42
HDS 1200 SG	780.31.92	304.8	12.00	2700	50	4.8	2.69

Standard length: 3.048 m - 10 feet (80 links)

The width (G) of the moulded-in rubber top varies per chain type:
92, 134, 192 and 252.5 mm for respectively HDS 450 SG, HDS 750 SG, HDS 1000 SG and HDS 1200 SG.

PLASTIC SUPERGRIP CHAINS

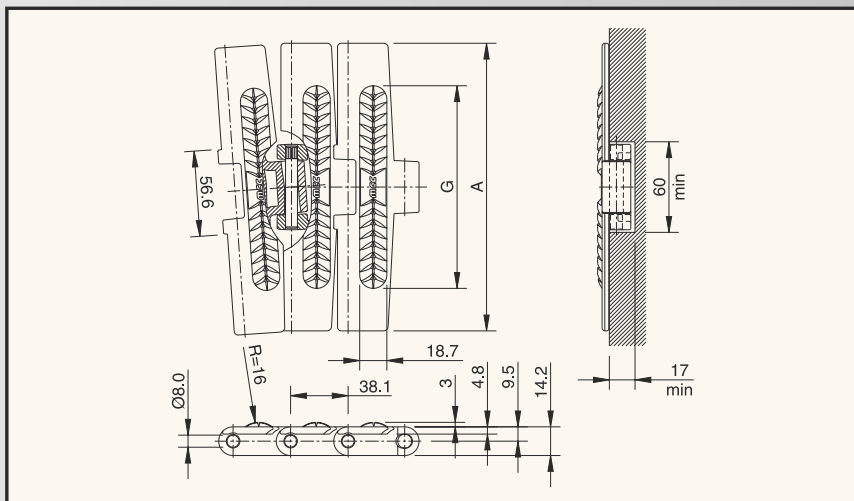
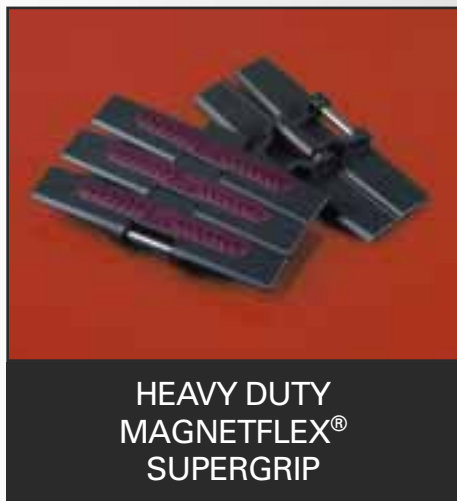

Chain type	Code nr.	Plate width		Working load (max.) N (21°C)	Backflex radius (min.) mm	Sideflex radius (min.) mm	Plate thickness mm	Weight kg/m
		A						
		mm	inch					
HDFM 750 SG	780.21.72	190.5	7.50	2700	50	610	4.8	2.10
HDFM 1000 SG	780.21.90	254.0	10.00	2700	50	610	4.8	2.42
HDFM 1200 SG	780.21.92	304.8	12.00	2700	50	610	4.8	2.69

Standard length: 3.048 m - 10 feet (80 links)

The width (G) of the moulded-in rubber top varies per chain type:
134, 192 and 251 mm for respectively HDFM 750 SG, HDFM 1000 SG and HDFM 1200 SG.

MCC PLASTIC MULTIFLEX CHAINS

The plastic multiflex chain is made for box-conveyors, spiral conveyors and small radius curves, which are typically used for food cans, glasswork, milk cartons and also some bakery applications.



TYPICAL CARTON CONVEYOR WITH PLASTIC MULTIFLEX CHAIN.

BENEFITS

- Optimum product handling**
Low friction material and bevelled edges ensure a smooth product flow.
- High working load**
The typical running conditions require high strength.
- Long wearlife**
Material and product finish guarantee less wear.

PROGRAMME

- Without tabs**
These chains for straight applications are available in pivot radius (PR), pivot radius with pusher (PRP) and pivot radius with detainer (PRD).
- With tabs**
For constructions with curves, these chains are obtainable in pivot radius with tabs (PRT), pivot radius with tabs and pusher (PRTP) and pivot radius with tabs and detainer (PRTD).
- For corner discs**
PR 1700 chains have edge grooves for corner disc applications.



JUICE PACKS ON PR 200 CHAIN.

AND . . .

The MCC plastic multiflex chains are moulded in light brown, extra low friction XL-polyacetal. The PR1700 is also available in white, wear-resistant NC-polyacetal.

PLASTIC MULTIFLEX CHAINS

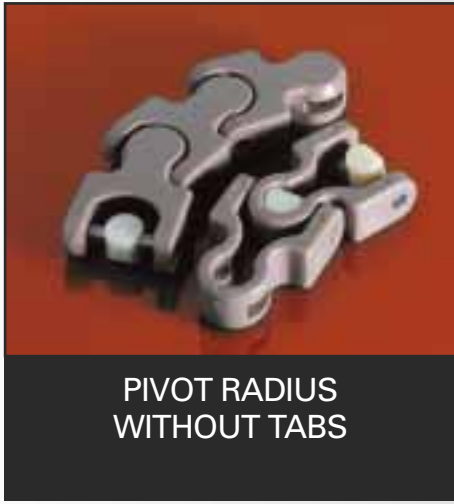

**PIVOT RADIUS
WITHOUT TABS**

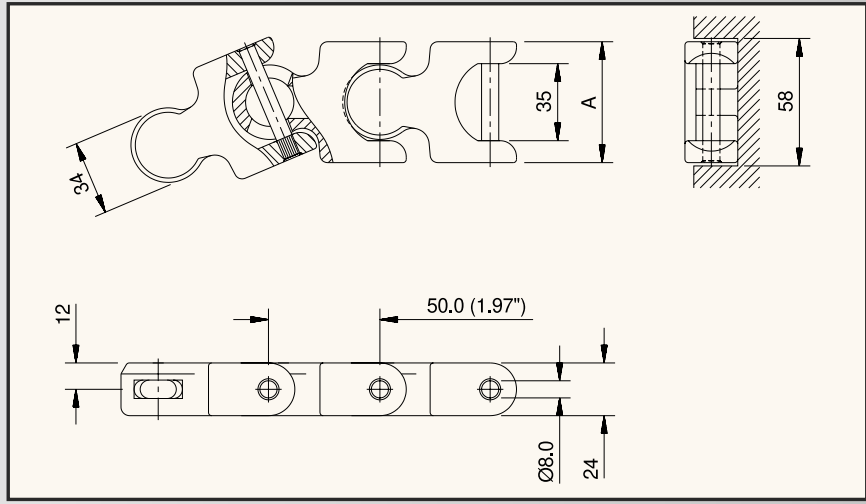

Chain type	Code nr.	Link width		Working load (max.) N (21°C)	Backflex radius (min.) mm	Sideflex radius (min.) mm	Weight kg/m
		A mm	inch				
XL-MATERIAL							
PR 200 XL	752.12.01	55.0	2.17	3330	50	150	1.55

Standard length: 3.05 m - 10 feet (61 links).

Packaging: two strands of 3.05 m per box.

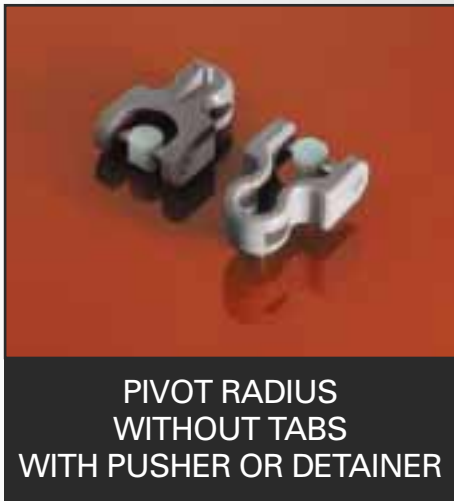

**PIVOT RADIUS
WITHOUT TABS
WITH PUSHER OR DETAINER**

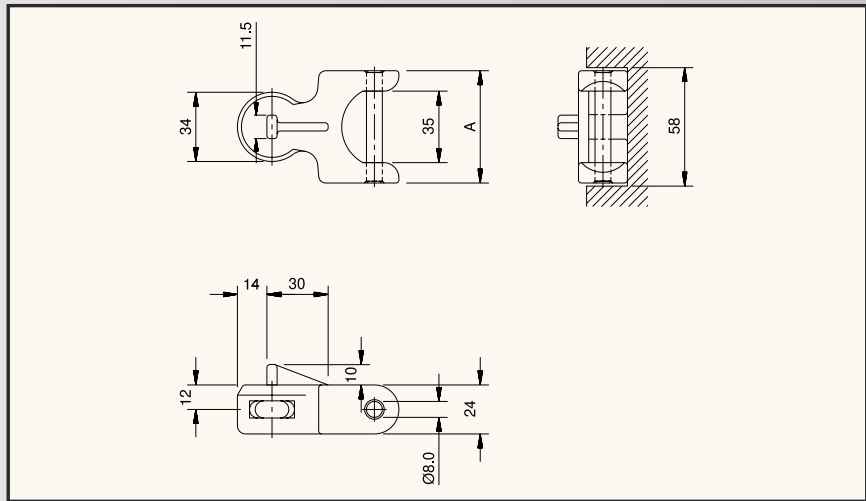

Chain type	Code nr.	Link width		Working load (max.) N (21°C)	Backflex radius (min.) mm	Sideflex radius (min.) mm	Weight kg/m
		A mm	inch				
XL-MATERIAL							
PRP 200 XL ¹	752.09.62	55.0	2.17	3330	50	150	1.60
PRD 200 XL	752.09.64	55.0	2.17	3330	50	150	1.60

¹ Shown in picture and drawing.

Links supplied per piece with pivot and pin.

PRP for inclined conveyors and PRD for declined conveyors.

PLASTIC MULTIFLEX CHAINS

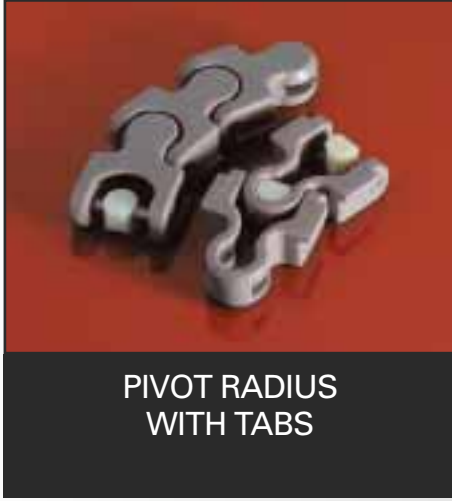

PIVOT RADIUS WITH TABS

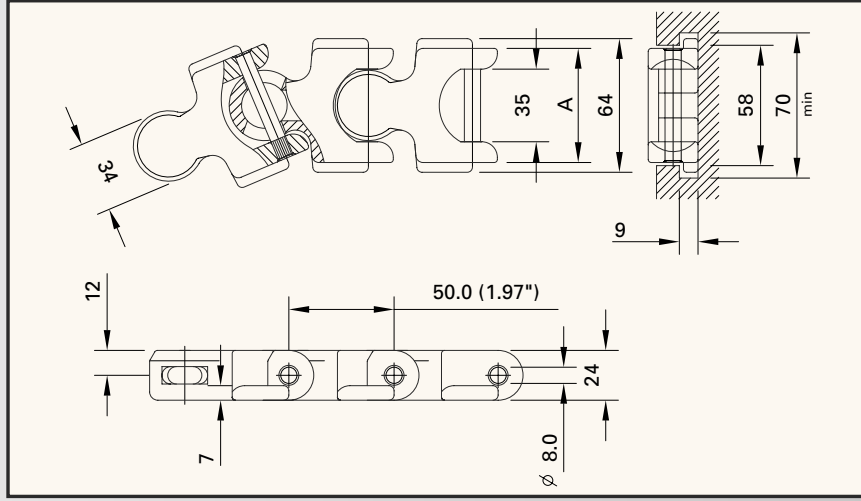

Chain type	Code nr.	Link width		Working load (max.) N (21°C)	Backflex radius (min.) mm	Sideflex radius (min.) mm	Weight kg/m
		A mm	A inch				
XL-MATERIAL							
PRT 200 XL	752.12.02	55.0	2.17	3330	50	150	1.60

Standard length: 3.05 m - 10 feet (61 links).

Packaging: two strands of 3.05 m per box.



PIVOT RADIUS WITH TABS WITH PUSHER OR DETAINER

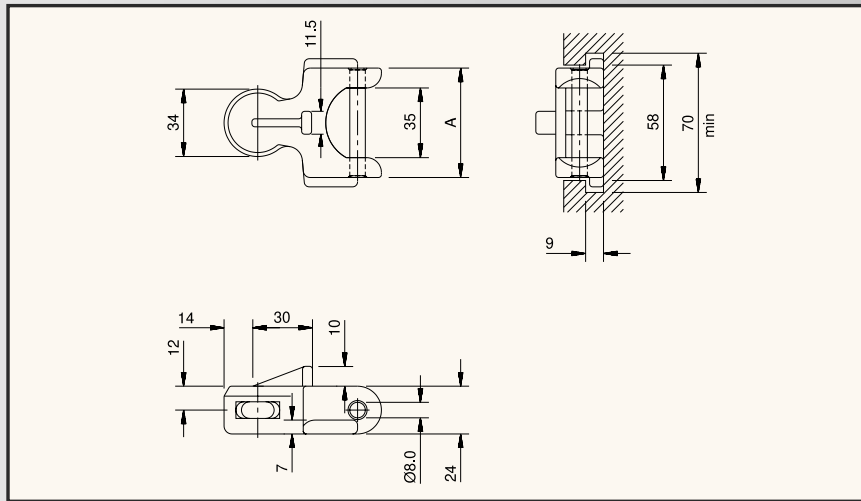

Chain type	Code nr.	Link width		Working load (max.) N (21°C)	Backflex radius (min.) mm	Sideflex radius (min.) mm	Weight kg/m
		A mm	A inch				
XL-MATERIAL							
P RTP 200 XL	752.09.63	55.0	2.17	3330	50	150	1.65
P RTD 200 XL ¹	752.09.65	55.0	2.17	3330	50	150	1.65

¹ Shown in picture and drawing.

Links supplied per piece with pivot and pin.

P RTP for inclined conveyors and P RTD for declined conveyors.

PLASTIC MULTIFLEX CHAINS

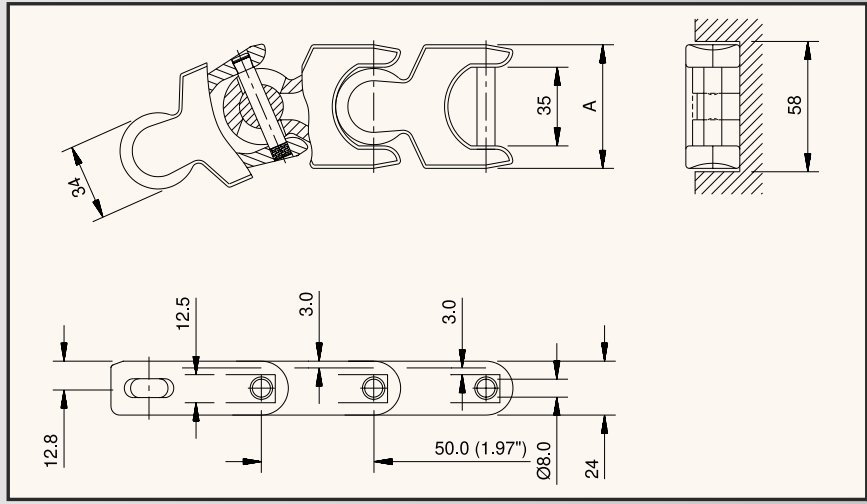

Chain type	Code nr.	Link width		Working load (max.) N (21°C)	Backflex radius (min.) mm	Sideflex radius (min.) mm	Weight kg/m
		A					
		mm	inch				
XL-MATERIAL							
PR 1700 XL	752.12.11	55.0	2.17	3000	50	125	1.26
NC-MATERIAL							
PR 1700 NC	752.15.11	55.0	2.17	3000	50	125	1.26

Standard length: 3.05 m - 10 feet (61 links).

Packaging: two strands of 3.05 m per box.

mcc PLASTIC CASE CONVEYOR CHAINS

The plastic case conveyor chain is used for heavy cases and crates.



HEAVY DUTY CRATE CONVEYOR WITH PLASTIC CASE CONVEYOR CHAIN.

BENEFITS

- Optimum product handling**
Extra low friction and bevelled edges ensure a smooth product flow.
- High strength**
The special links and pins offer the highest possible working load, important for the rough conditions these chains work in.
- Extended wearlife**
Design and material guarantee less wear, especially in the 631 and 1431 versions.
- Open construction**
Easy cleaning makes it suitable for dirty conditions.

PROGRAMME

- Straight run**
These chains are available in standard (600) and strong (1400) versions.
- Sideflex**
These chains have tabs, suitable for simple curve constructions; alongside the 600 and 1400 versions, they are also available in extra high 631 and 1431 versions for 40% longer wearlife.



CRATES WITH RETURNED BOTTLES ON OPEN, HYGIENIC CC 1400 CHAIN.

AND . . .

The MCC plastic case conveyor chains are moulded in light brown, extra low friction XL-polyacetal and in white, wear-resistant NC-polyacetal.

PLASTIC CASE CONVEYOR CHAINS



**STRAIGHT RUN
WITHOUT TABS**

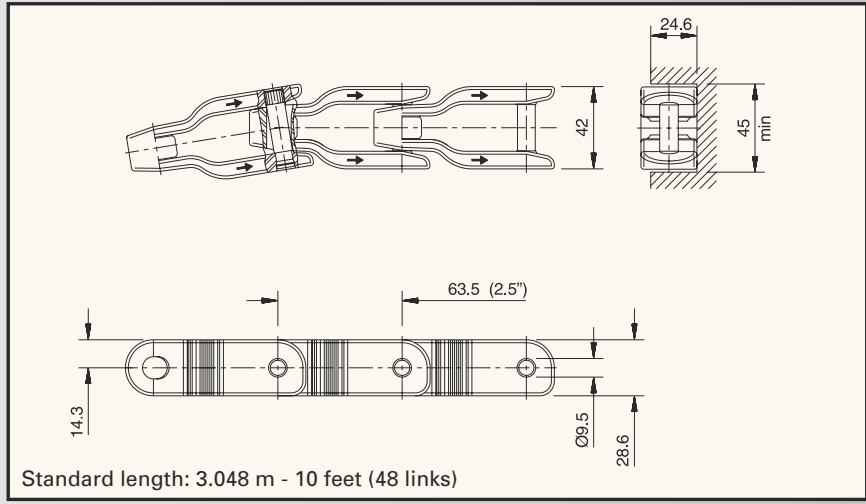

MATERIAL
page 158

page 129

Chain type	Code nr.	Link width A		Working load (max.) N (21°C)	Backflex radius (min.) mm	Sideflex radius (min.) mm	Weight kg/m
		mm	inch				
CC 600 XL	752.72.05	42.0	1.66	3950	50	457	1.20
CC 600 NC	752.75.05	42.0	1.66	3950	50	457	1.20



**SIDEFLEX
WITH TABS**

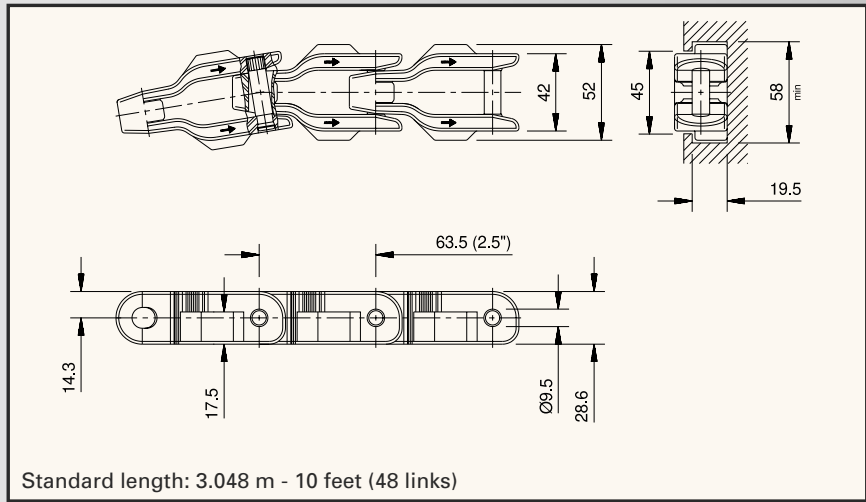

MATERIAL
page 158

page 129

Chain type	Code nr.	Link width A		Working load (max.) N (21°C)	Backflex radius (min.) mm	Sideflex radius (min.) mm	Weight kg/m
		mm	inch				
CC 600 TXL	752.72.04	42.0	1.66	3950	50	457	1.25
CC 600 TNC	752.75.04	42.0	1.66	3950	50	457	1.25



**SIDEFLEX
WITH TABS
WITH THICK LINK**

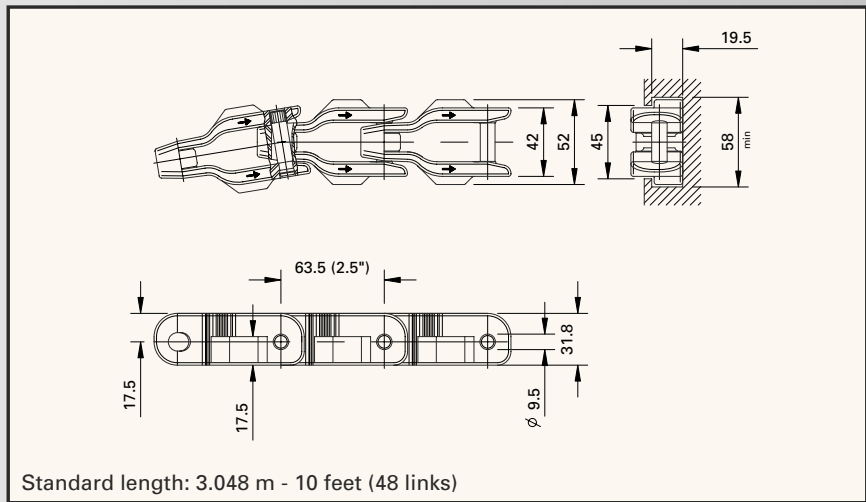

MATERIAL
page 158



page 129

Chain type	Code nr.	Link width A		Working load (max.) N (21°C)	Backflex radius (min.) mm	Sideflex radius (min.) mm	Weight kg/m
		mm	inch				
CC 631 TXL	752.42.04	42.0	1.66	3950	50	457	1.35
CC 631 TNC	752.45.04	42.0	1.66	3950	50	457	1.35

PLASTIC CASE CONVEYOR CHAINS

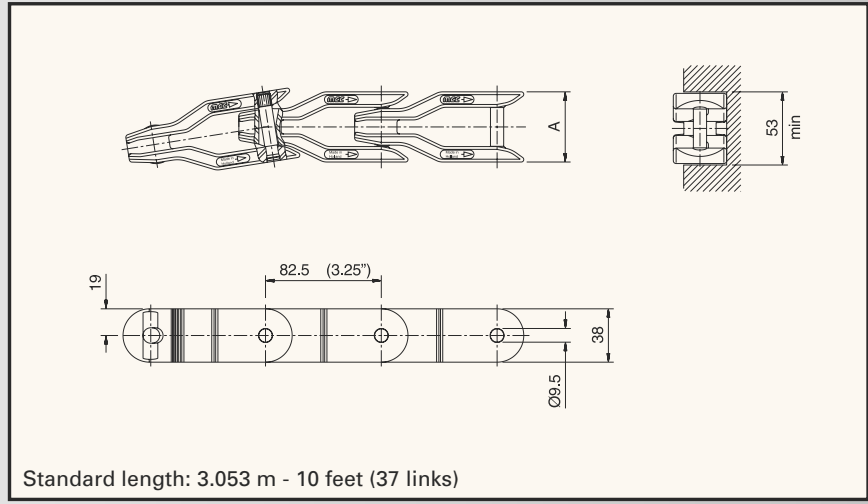

**STRAIGHT RUN
STRONG
WITHOUT TABS**



MATERIAL
page 158

page 129

Chain type	Code nr.	Link width A		Working load (max.) N (21°C)	Backflex radius (min.) mm	Sideflex radius (min.) mm	Weight kg/m
		mm	inch				
CC 1400 XL	752.32.05	50.0	1.97	6500	50	660	1.70
CC 1400 NC	752.35.05	50.0	1.97	6500	50	660	1.70



**SIDEFLEX
STRONG
WITH TABS**

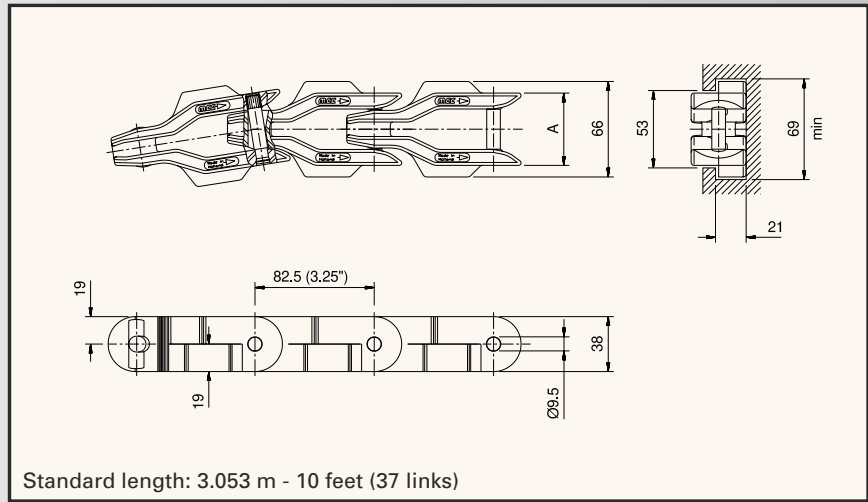

MATERIAL
page 158

page 129

Chain type	Code nr.	Link width A		Working load (max.) N (21°C)	Backflex radius (min.) mm	Sideflex radius (min.) mm	Weight kg/m
		mm	inch				
CC 1400 TXL	752.32.04	50.0	1.97	6500	50	660	1.75
CC 1400 TNC	752.35.04	50.0	1.97	6500	50	660	1.75



**SIDEFLEX
STRONG
WITH TABS WITH THICK LINK**

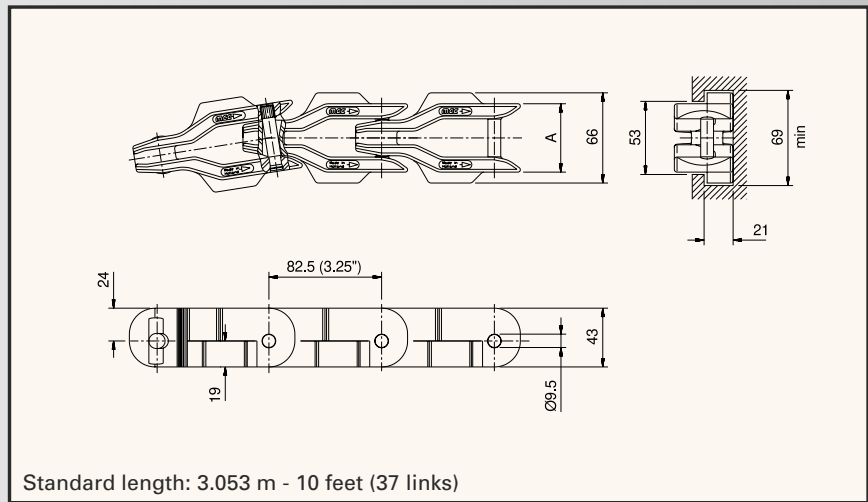

MATERIAL
page 158

page 129

Chain type	Code nr.	Link width A		Working load (max.) N (21°C)	Backflex radius (min.) mm	Sideflex radius (min.) mm	Weight kg/m
		mm	inch				
CC 1431 TXL	752.92.04	50.0	1.97	6500	50	660	2.02
CC 1431 TNC	752.95.04	50.0	1.97	6500	50	660	2.02

BELT CODE NUMBERS

Code nr. ending on	Type ending on/ Width		Code nr. ending on	Type ending on/ Width		Code nr. ending on	Type ending on/ Width	
	mm			mm			mm	
CODE NUMBERS FOR 500-, 1000- AND 1005-SERIES								
10	85		28	1615		46	3145	
11	170		29	1700		47	3230	
12	255		30	1785		48	3315	
13	340		31	1870		49	3400	
14	425		32	1955		50	3485	
15	510		33	2040		51	3570	
16	595		34	2125		52	3655	
17	680		35	2210		53	3740	
18	765		36	2295		54	3825	
19	850		37	2380		55	3910	
20	935		38	2465		56	3995	
21	1020		39	2550		57	4080	
22	1105		40	2635		58	4165	
23	1190		41	2720		59	4250	
24	1275		42	2805		60	4335	
25	1360		43	2890		61	4420	
26	1445		44	2975		62	4505	
27	1530		45	3060		63	4590	

Code nr. ending on	Type ending on/ Width		Code nr. ending on	Type ending on/ Width		Code nr. ending on	Type ending on/ Width		Code nr. ending on	Type ending on/ Width	
	mm	inch		mm	inch		mm	inch		mm	inch
CODE NUMBERS FOR 2000- AND 2500-SERIES											
10	76	3	30	1600	63	50	3124	123	70	4648	183
11	152	6	31	1676	66	51	3200	126	71	4724	186
12	229	9	32	1753	69	52	3277	129	72	4801	189
13	305	12	33	1829	72	53	3353	132	73	4877	192
14	381	15	34	1905	75	54	3429	135	74	4953	195
15	457	18	35	1981	78	55	3505	138	75	5029	198
16	533	21	36	2057	81	56	3581	141	76	5105	201
17	610	24	37	2134	84	57	3657	144	77	5182	204
18	686	27	38	2210	87	58	3734	147	78	5258	207
19	762	30	39	2286	90	59	3810	150	79	5334	210
20	838	33	40	2362	93	60	3886	153	80	5410	213
21	914	36	41	2438	96	61	3962	156	81	5486	216
22	991	39	42	2515	99	62	4039	159	82	5563	219
23	1067	42	43	2591	102	63	4115	162	83	5639	222
24	1143	45	44	2667	105	64	4191	165	84	5715	225
25	1219	48	45	2743	108	65	4267	168	85	5791	228
26	1295	51	46	2819	111	66	4343	171	86	5867	231
27	1372	54	47	2896	114	67	4420	174	87	5944	234
28	1448	57	48	2972	117	68	4496	177	88	6020	237
29	1524	60	49	3048	120	69	4572	180	89	6096	240



500-SERIES MODULAR BELTS

The 500-series belt is the best product for conveyors with extremely small deadplate transfers. The pitch of 0.5 inch makes this belt the smallest available in the world. 500-Series belts are ideal for the can manufacturing industry and have been successfully used on the infeed of packing machines in the bottling industry, for example.



SMOOTH CAN CONVEYORS WITH 500-SERIES PLASTIC BELT.

BENEFITS

- Continuous product flow**
Due to the small deadplate transfers, your products will keep on moving, pressure-free.
- Superior product handling**
The surface design and minimal cordal action result in excellent stability for products such as tall aerosol cans and pet bottles.
- Easy installation and maintenance**
The pin retention clips can be easily fitted and removed from the side.
- Smooth sides**
The flush belt sides enable two belts to run adjacently without a gap between them, even at different speeds.

PROGRAMME

- Flush Grid (FG)**
The belt has 16% open area.
- Flush Grid with Positrack (FGP)**
Positrack on the left or on the right or on both sides.

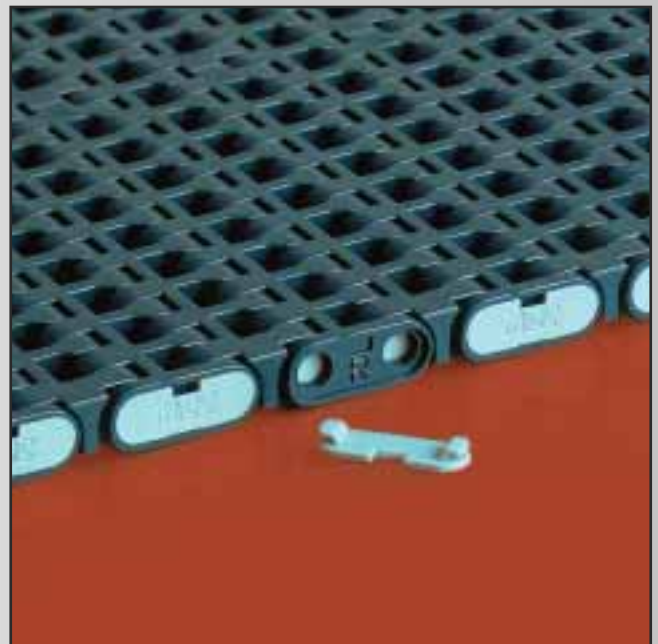

PIN RETENTION CLIPS FOR EASY INSTALLATION AND MAINTENANCE OF THE BELT.

AND . . .

500-Series belts are made of green-blue, extra low friction XLG-polyacetal. The belts can be supplied from stock in standard lengths up to 680 mm wide; wider belts will be tailor-made on request.

Positrack is a guiding lug under the modules, especially advantageous for narrow belts and side transfers, keeping the belt in position.

500-SERIES MODULAR CONVEYOR BELTS

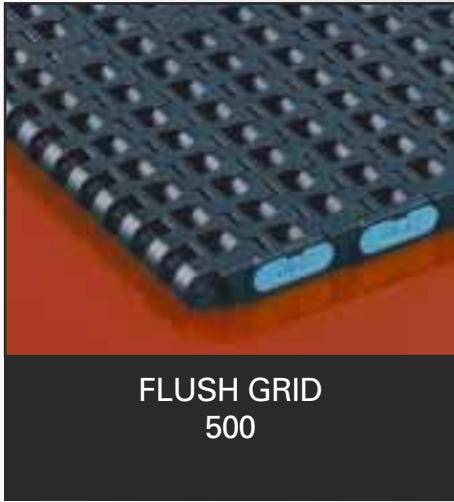

**FLUSH GRID
500**

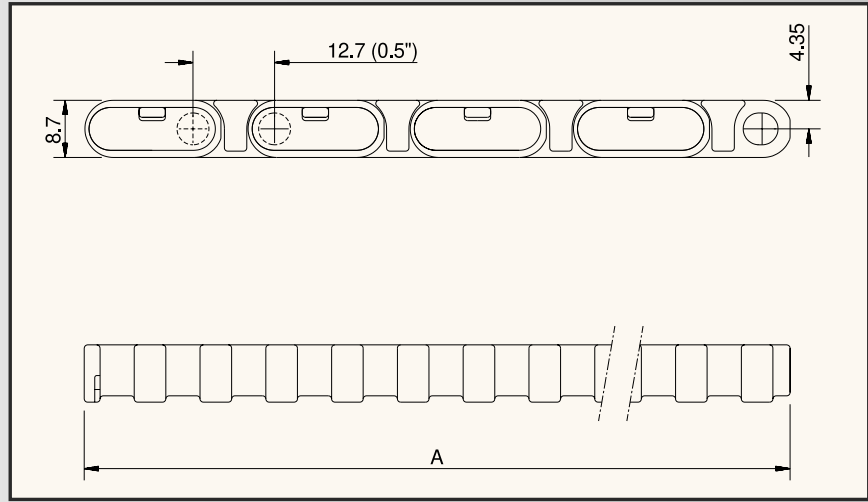

Assembly	Belt type	Code nr. last two digits depending on width A	Temp. range dry	Temp. range wet	Working load (max.) N/m (21°C)	Weight kg/m ²	Backflex radius (min.) mm
			°C	°C			
XLG-MATERIAL (POLYACETAL, GREEN-BLUE)							
STANDARD	FG 500 XLG 85	857.40.10	4 to 80	4 to 65	13000	6.00	8
	FG 500 XLG 6120	857.40.81					
POSITRACK ONE SIDE, LEFT MODULE	FGP 500 XLG 85	874.05.10	4 to 80	4 to 65	13000	6.00	8
	FGP 500 XLG 6120	874.05.81					
POSITRACK ONE SIDE, RIGHT MODULE	FGP 500 XLG 85	874.06.10	4 to 80	4 to 65	13000	6.00	8
	FGP 500 XLG 6120	874.06.81					
POSITRACK TWO SIDES	FGP 500 XLG 85	874.04.10	4 to 80	4 to 65	13000	6.00	8
	FGP 500 XLG 6120	874.04.81					

0.5" Pitch.

Standard length for belts up to a width of 680 mm: 3.048 m - 10 feet.

Wider belts available in any length.

For information on Positrack or tolerances for specified belt widths, please contact our Technical Support department.

Code nrs.: xx.xx.10 up to xx.xx.81 for widths 85 up to 6120, steps 85 mm.

For a listing of the last two digits in the code numbers for every belt width, please refer to the table on page 37.

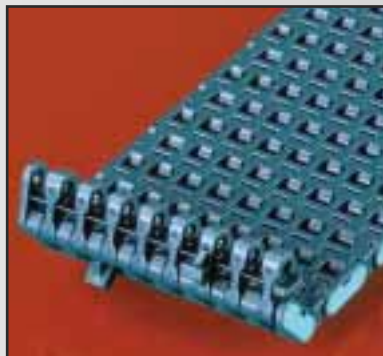

FLUSH GRID 500 BELT WITH POSITRACK

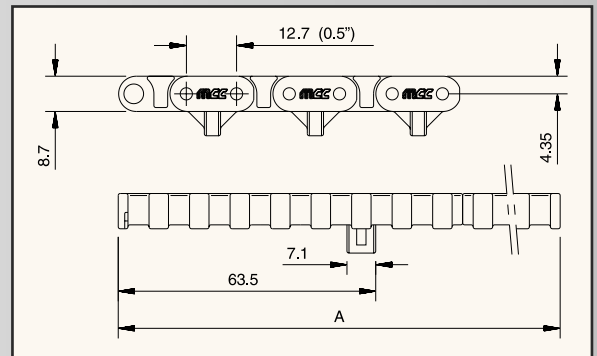

The 1000-series belt is multifunctional. The pitch is 1 inch.

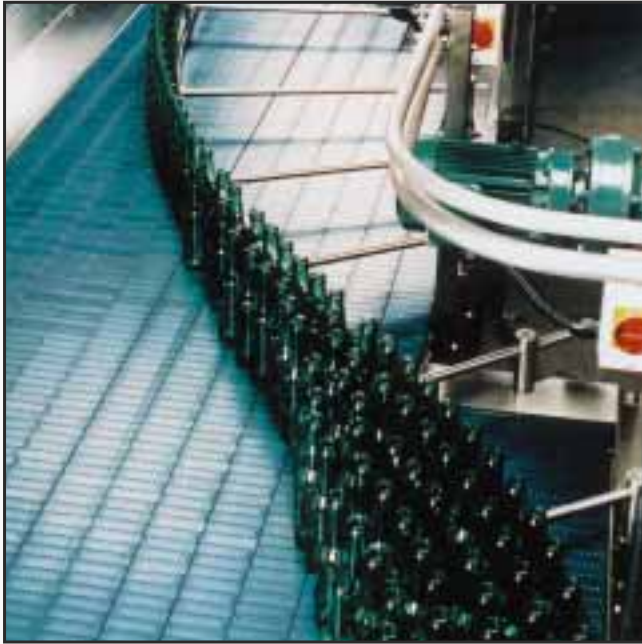

EMPTY GLASS BOTTLE CONVEYOR ON INLINER WITH 1000-SERIES PLASTIC BELT.

BENEFITS

- Perfect product handling**
 1000-Series belts have a relatively small 1" pitch, the material has a very low friction and the superior stiffness of the module means optimum belt flatness.
- Easy installation and maintenance**
 The pin retention clips can be easily fitted and removed. This allows for very easy access to the belt.
- Smooth sides**
 Flush belt edges enable two belts to run adjacently without a gap, even at different speeds.
- Long wearlife**
 Due to the extra low friction material, the belt will have a long wearlife, even under heavy duty conditions.

PROGRAMME

- Flush Grid**
 The 40% open area of Flush Grid belts guarantees optimum flow of water, dirt and air; it also makes cleaning very easy. At the same time, the large support area ensures long life. It is suitable for cans and flat-base PET bottles. Flush Grid is obtainable in a standard version (FG), with Positrack guiding lugs (FGDP) and with integrated FreeFlow and Positrack (FFGP).
- Flat Top**
 The closed surface makes Flat Top belts suitable for glass bottles and difficult petaloid bottles. Flat Top is obtainable in a standard version (FT), with Positrack (FTDP) and with integrated FreeFlow and Positrack (FFTP).
- Inliner belts**
 This 84 mm wide belt has been designed especially for inliners, to avoid any contact between the various tracks running at different speeds. Therefore both Flush Grid (FGDP) and Flat Top (FTDP) always have double Positrack. Open area FGDP is 40%.
- Raised Rib**
 The Raised Rib belts (RR) create smooth transfers on accumulation tables, depalletisers and discharge tables, in combination with special click-comb fingerplates. Open area is 40%, for narrow belts 13%.

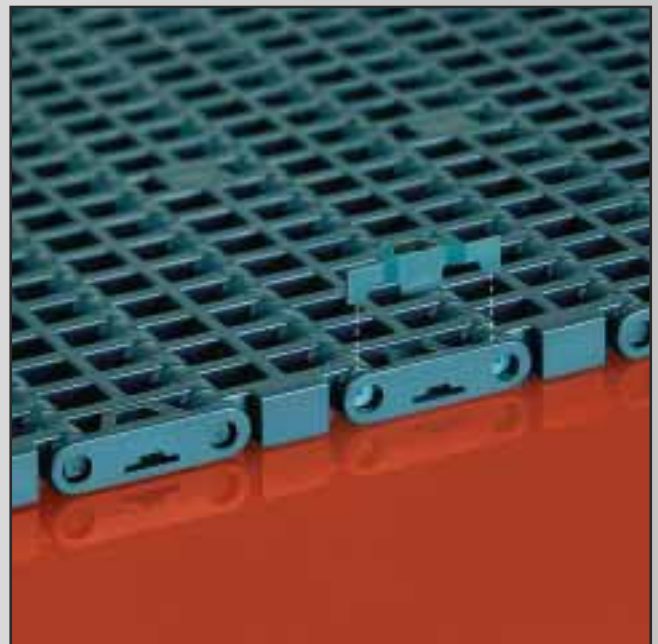

PIN RETENTION CLIPS FOR EASY INSTALLATION AND MAINTENANCE OF THE BELT.

AND . . .

1000-Series belts are mainly made of green-blue, extra low friction XLG-polyacetal. Light green XP-polypropylene is used in situations where optimum temperature (up to 104°C) and chemical resistance is required. We can also produce black AS-polyacetal, an anti-static, improved conduction material for applications where static electricity should be avoided, e.g. on aerosol filling lines. The XLG-belts can be supplied from stock in standard lengths up to 680 mm wide; wider belts will be tailor-made on request.

FreeFlow is a system of integrated, tapered flights at the edge of the belt which allows for 90° transfers.

Double Positrack in 1000-series consists of 2 guiding lugs on one side.

1000-SERIES MODULAR CONVEYOR BELTS



**FLUSH GRID
1000**

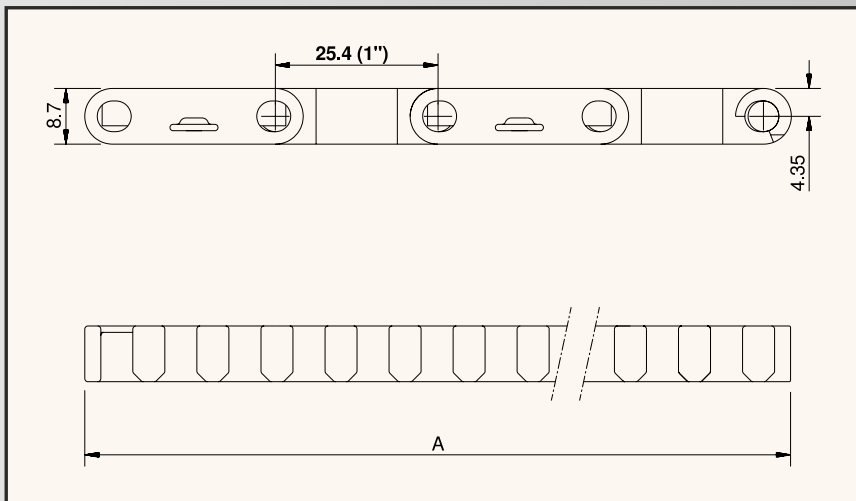

Assembly	Belt type	Code nr. last two digits depending on width A	Temp. range dry	Temp. range wet	Working load (max.) N/m (21°C)	Weight kg/m ²	Backflex radius (min.) mm
			°C	°C			
XLG-MATERIAL (POLYACETAL, GREEN-BLUE)							
STANDARD	FG 1000 XLG 85	817.40.10	4 to 80	4 to 65	22000	5.40	25
	FG 1000 XLG 6120	817.40.81					
DOUBLE POSITRACK	FGDP 1000 XLG 85	874.43.10	4 to 80	4 to 65	22000	5.40	25
	FGDP 1000 XLG 6120	874.43.81					
POSITRACK ONE SIDE FREEFLOW ONE SIDE	FFGP 1000 XLG 85	874.08.10	4 to 80	4 to 65	22000	5.40	30
	FFGP 1000 XLG 6120	874.08.81					
POSITRACK TWO SIDES FREEFLOW ONE SIDE	FFGP 1000 XLG 85	874.07.10	4 to 80	4 to 65	22000	5.40	30
	FFGP 1000 XLG 6120	874.07.81					
INLINER BELT DOUBLE POSITRACK	FGDP 1000 XLG 84	874.30.09	-30 to 80	up to 65	22000	5.40	25
XP-MATERIAL (POLYPROPYLENE, LIGHT GREEN)							
STANDARD	FG 1000 XP 85	818.40.10	4 to 104	4 to 104	11000	3.53	25
	FG 1000 XP 6120	818.40.81					
DOUBLE POSITRACK	FGDP 1000 XP 85	874.45.10	4 to 104	4 to 104	11000	3.53	25
	FGDP 1000 XP 6120	874.45.81					
AS-MATERIAL (ANTI-STATIC POLYACETAL, BLACK)							
STANDARD	FG 1000 AS 85	814.40.10	4 to 80	-	13000	5.08	25
	FG 1000 AS 6120	814.40.81					
DOUBLE POSITRACK	FGDP 1000 AS 85	874.48.10	4 to 80	-	13000	5.08	25
	FGDP 1000 AS 6120	874.48.81					

1" Pitch.

Standard length for belts up to a width of 680 mm: 3.048 m - 10 feet. Wider belts available in any length.

For information on Positrack and FreeFlow or tolerances for specified belt widths, please contact our Technical Support department.

Code nrs.: xx.xx.10 up to xx.xx.81 for widths 85 up to 6120, steps 85 mm.

For a listing of the last two digits in the code numbers for every belt width, please refer to the table on page 37.

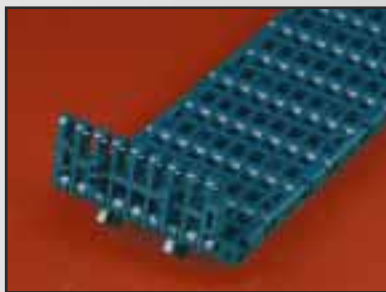

FLUSH GRID 1000 BELT WITH DOUBLE POSITRACK



FLUSH GRID 1000 BELT WITH INTEGRATED FREEFLOW

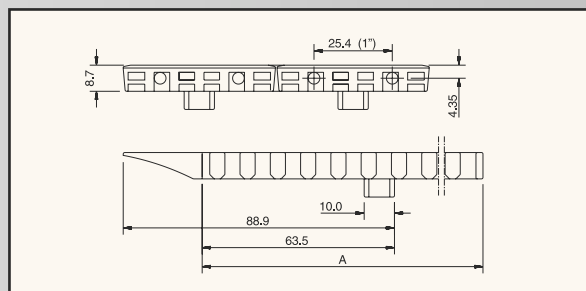
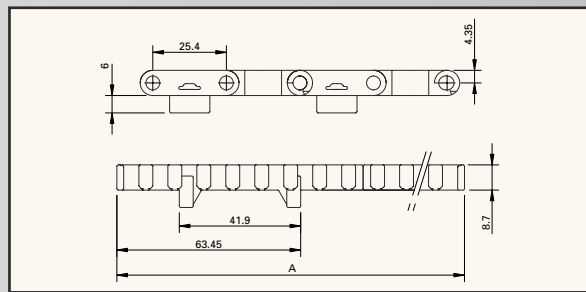

1000-SERIES MODULAR CONVEYOR BELTS

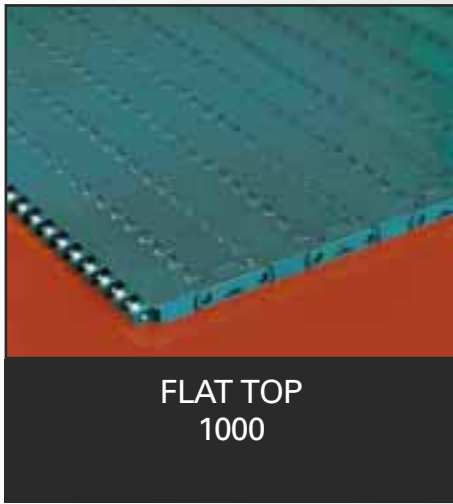

**FLAT TOP
1000**

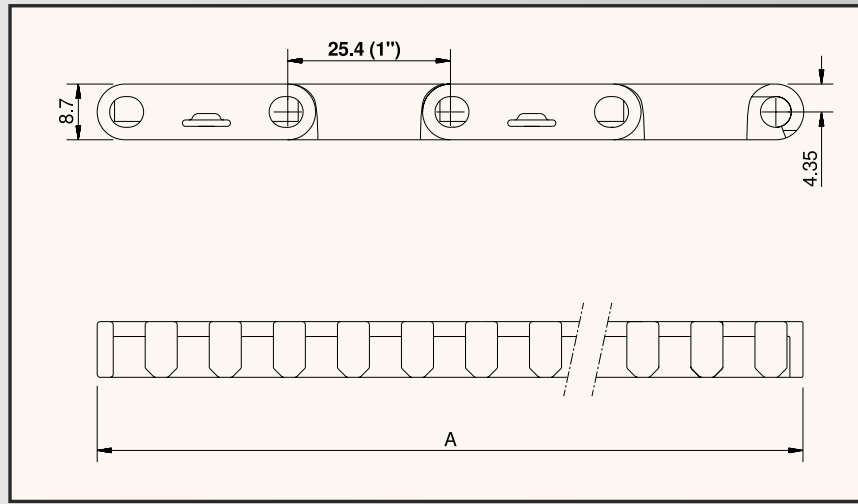

page 149, 150



page 158



page 131

Assembly	Belt type	Code nr. last two digits depending on width A	Temp. range dry	Temp. range wet	Working load (max.) N/m (21°C)	Weight kg/m ²	Backflex radius (min.) mm
			°C	°C			
XLG-MATERIAL (POLYACETAL, GREEN-BLUE)							
STANDARD	FT 1000 XLG 85	817.30.10	4 to 80	4 to 65	22000	6.50	30
	FT 1000 XLG 6120	817.30.81					
DOUBLE POSITRACK	FTDP 1000 XLG 85	873.27.10	4 to 80	4 to 65	22000	6.50	30
	FTDP 1000 XLG 6120	873.27.81					
POSITRACK ONE SIDE FREEFLOW ONE SIDE	FFTP 1000 XLG 85	873.08.10	4 to 80	4 to 65	22000	6.50	30
	FFTP 1000 XLG 6120	873.08.81					
POSITRACK TWO SIDES FREEFLOW ONE SIDE	FFTP 1000 XLG 85	873.07.10	4 to 80	4 to 65	22000	6.50	30
	FFTP 1000 XLG 6120	873.07.81					
INLINER BELT DOUBLE POSITRACK	FTDP 1000 XLG 84	873.21.09	-30 to 80	up to 65	22000	6.50	30
XP-MATERIAL (POLYPROPYLENE, LIGHT GREEN)							
STANDARD	FT 1000 XP 85	818.30.10	4 to 104	4 to 104	11000	4.25	30
	FT 1000 XP 6120	818.30.81					
DOUBLE POSITRACK	FTDP 1000 XP 85	873.29.10	4 to 104	4 to 104	11000	4.25	30
	FTDP 1000 XP 6120	873.29.81					
AS-MATERIAL (ANTI-STATIC POLYACETAL, BLACK)							
STANDARD	FT 1000 AS 85	814.30.10	4 to 80	-	13000	6.11	30
	FT 1000 AS 6120	814.30.81					
DOUBLE POSITRACK	FTDP 1000 AS 85	873.32.10	4 to 80	-	13000	6.11	30
	FTDP 1000 AS 6120	873.32.81					

1" Pitch.

Standard length for belts up to a width of 680 mm: 3.048 m - 10 feet. Wider belts available in any length.

For information on Positrack and FreeFlow or tolerances for specified belt widths, please contact our Technical Support department.

Code nrs.: xx.xx.10 up to xx.xx.81 for widths 85 up to 6120, steps 85 mm.

For a listing of the last two digits in the code numbers for every belt width, please refer to the table on page 37.

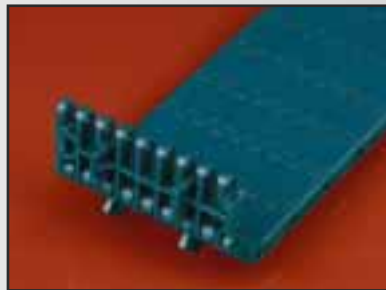

FLAT TOP 1000 BELT WITH DOUBLE POSITRACK

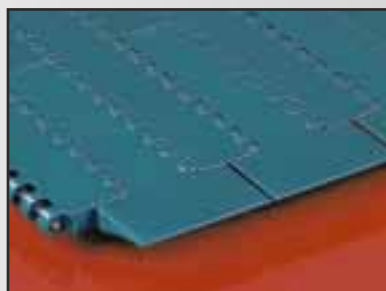

FLAT TOP 1000 BELT WITH INTEGRATED FREEFLOW

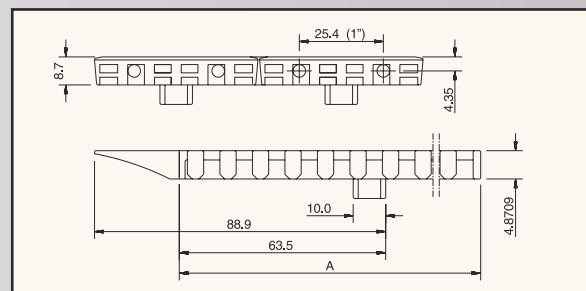
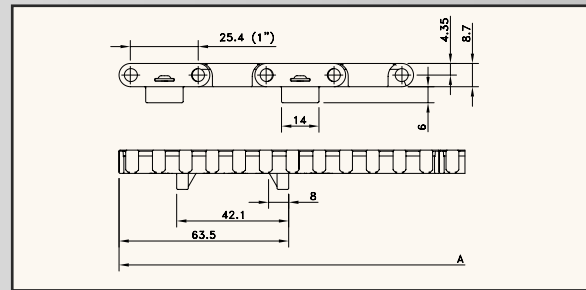

1000-SERIES MODULAR CONVEYOR BELTS



**RAISED RIB
1000**

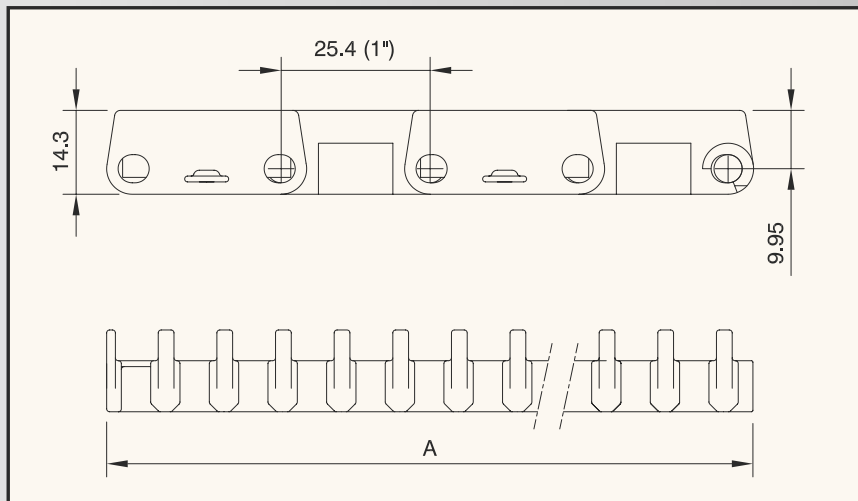

Assembly	Belt type	Code nr. last two digits depending on width A	Temp. range dry	Temp. range wet	Working load (max.) N/m (21°C)	Weight kg/m ²	Backflex radius (min.) mm
			°C	°C			
XLG-MATERIAL (POLYACETAL, GREEN-BLUE)							
STANDARD	RR 1000 XLG 85	817.10.10	4 to 80	4 to 65	22000	7.95	50
	RR 1000 XLG 6120	817.10.81					
XP-MATERIAL (POLYPROPYLENE, LIGHT GREEN)							
STANDARD	RR 1000 XP 85	818.10.10	4 to 104	4 to 104	11000	5.20	50
	RR 1000 XP 6120	818.10.81					
AS-MATERIAL (ANTI-STATIC POLYACETAL, BLACK)							
STANDARD	RR 1000 AS 85	814.10.10	4 to 80	-	13000	7.47	50
	RR 1000 AS 6120	814.10.81					

1" Pitch.

Standard length for belts up to a width of 680 mm: 3.048 m - 10 feet. Wider belts available in any length.

For information on tolerances for specified belt widths, please contact our Technical Support department.

Code nrs.: xx.xx.10 up to xx.xx.81 for widths 85 up to 6120, steps 85 mm.

For a listing of the last two digits in the code numbers for every belt width, please refer to the table on page 37.

1000-SERIES MODULAR CONVEYOR BELTS

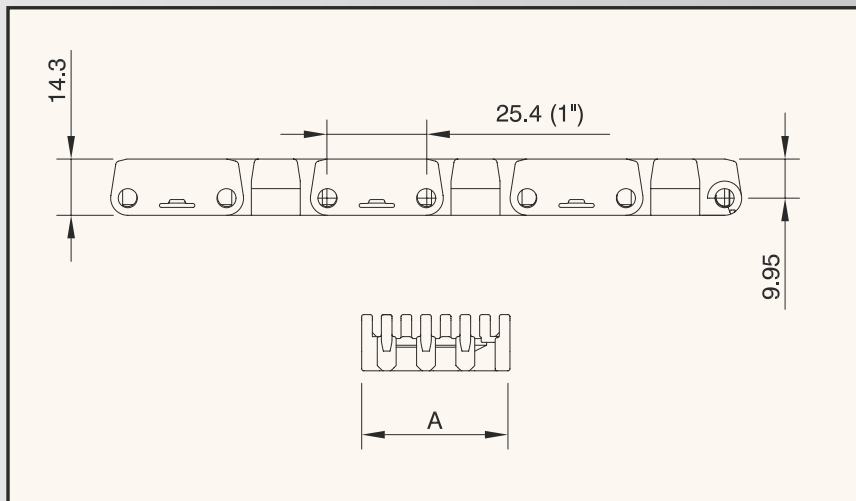

Assembly	Belt type	Code nr.	Width	Temp. range dry	Temp. range wet	Working load (max.) N (21°C)	Weight kg/m	Backflex radius (min.) mm
			A mm	°C	°C			
XLG-MATERIAL (POLYACETAL, GREEN-BLUE)								
STANDARD	RR 1000-38 XLG	871.01.00	38	-30 to 80	up to 65	400	0.39	50
	RR 1000-48 XLG	871.01.01	48	-30 to 80	up to 65	600	0.48	50
	RR 1000-58 XLG	871.01.02	58	-30 to 80	up to 65	800	0.59	50
XP-MATERIAL (POLYPROPYLENE, LIGHT GREEN)								
STANDARD	RR 1000-38 XP	871.03.00	38	4 to 104	4 to 104	200	0.26	50
	RR 1000-48 XP	871.03.01	48	4 to 104	4 to 104	300	0.31	50
	RR 1000-58 XP	871.03.02	58	4 to 104	4 to 104	400	0.38	50

1" Pitch.

Standard length: 3.048 m - 10 feet.

1000-SERIES MODULAR CONVEYOR BELTS

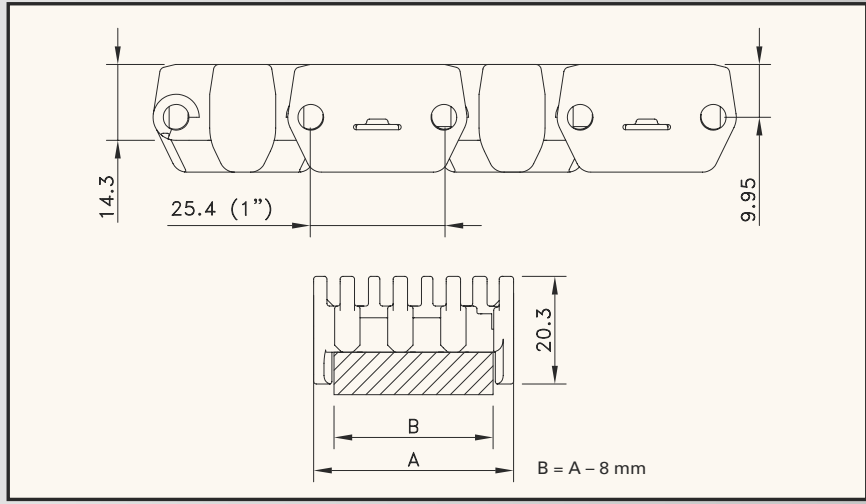

Assembly	Belt type	Code nr.	Width	Temp. range dry	Temp. range wet	Working load (max.) N (21°C)	Weight kg/m	Backflex radius (min.) mm
			A mm	°C	°C			
XLG-MATERIAL (POLYACETAL, GREEN-BLUE)								
STANDARD	RRR 1000-28 XLG	871.00.03	28	-30 to 80	up to 65	200	0.33	50
	RRR 1000-38 XLG	871.00.00	38	-30 to 80	up to 65	400	0.43	50
	RRR 1000-48 XLG	871.00.01	48	-30 to 80	up to 65	600	0.53	50
	RRR 1000-58 XLG	871.00.02	58	-30 to 80	up to 65	800	0.62	50
XP-MATERIAL (POLYPROPYLENE, LIGHT GREEN)								
STANDARD	RRR 1000-38 XP	871.02.00	38	4 to 104	4 to 104	200	0.28	50
	RRR 1000-48 XP	871.02.01	48	4 to 104	4 to 104	300	0.35	50
	RRR 1000-58 XP	871.02.02	58	4 to 104	4 to 104	400	0.41	50

1" Pitch.

Standard length: 3.048 m - 10 feet.

The *SuperGrip belt* is an excellent solution for inclined and declined conveying. This belt consists of standard MCC 1000-series Flush Grid modules and special moulded rubber top modules. SuperGrip belts are ideal for large packs such as cardboard trays, many crates and shrink-wrapped packages.



INCLINED TRAY CONVEYOR WITH PLASTIC SUPERGRIP BELT.

BENEFITS

- Maximum grip**
The grooves in the rubber pad improve the grip.
- Hygienic rubber top**
Due to the groove design in the rubber top, cleaning is very easy.
- Optimum belt support in the return part**
Flat areas in the pad ensure easy support by rollers.
- 100% secure bonding**
The state-of-the-art moulding process guarantees excellent chemical and mechanical bonding.
- Long-life rubber top**
Pad design and material give SuperGrip belts a long life.
- Inclines up to 20°**
Adequate for most applications. The actual angle that can be used depends on product and circumstances. If you have any doubts, please ask our Technical Support department.

PROGRAMME

- XP-material, polypropylene (light green)**
This belt is the standard and most cost-effective solution.
- PG-material, PBT (green-blue)**
This belt is intended for higher speeds and loads.



BOXES WITH CARTONS ON PARTIALLY RUBBER COVERED SUPERGRIP BELT.

AND . . .

The rubber top is made of a special black elastomere. The rubber coverage is 100%; other percentages can be supplied upon request.

1000-SERIES SUPERGRIP BELTS



**SUPERGRIP
1000**

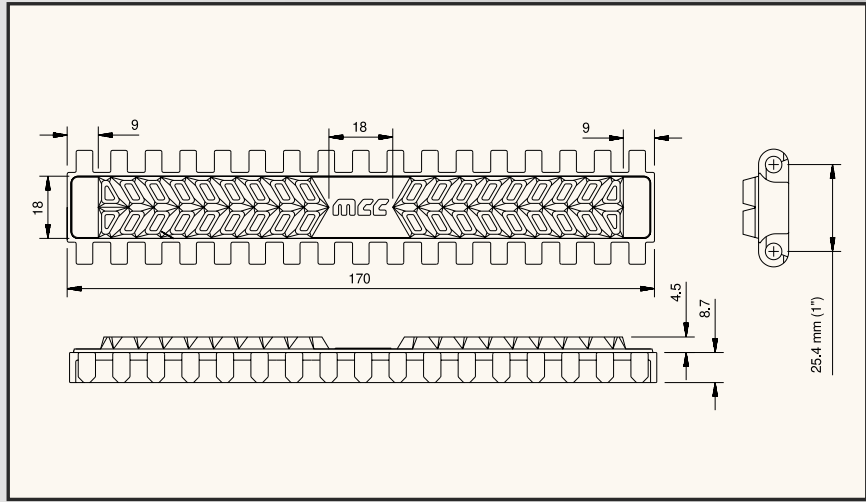

Assembly	Belt type	Code nr.	Width	Temperature range dry	Temperature range wet	Working load (max.)	Weight	Backflex radius (min.)
			A	°C	°C			
XP-MATERIAL (POLYPROPYLENE, LIGHT GREEN)								
STANDARD 100% RUBBER	SG 1000 XP 170	875.00.11	170	4 to 65	4 to 65	11000	5.00	30
	SG 1000 XP 255	875.00.12	255	4 to 65	4 to 65	11000	5.33	30
	SG 1000 XP 340	875.00.13	340	4 to 65	4 to 65	11000	5.50	30
	SG 1000 XP 425	875.00.14	425	4 to 65	4 to 65	11000	5.60	30
	SG 1000 XP 510	875.00.15	510	4 to 65	4 to 65	11000	5.66	30
	SG 1000 XP 595	875.00.16	595	4 to 65	4 to 65	11000	5.71	30
DOUBLE POSITRACK 100% RUBBER	SGDP 1000 XP 170	875.54.11	170	4 to 65	4 to 65	11000	5.00	30
	SGDP 1000 XP 255	875.54.12	255	4 to 65	4 to 65	11000	5.33	30
	SGDP 1000 XP 340	875.54.13	340	4 to 65	4 to 65	11000	5.50	30
	SGDP 1000 XP 425	875.54.14	425	4 to 65	4 to 65	11000	5.60	30
	SGDP 1000 XP 510	875.54.15	510	4 to 65	4 to 65	11000	5.66	30
	SGDP 1000 XP 595	875.54.16	595	4 to 65	4 to 65	11000	5.71	30
PG-MATERIAL (PBT, GREEN-BLUE)								
STANDARD 100% RUBBER	SG 1000 PG 170	875.30.11	170	4 to 65	4 to 65	15000	7.34	30
	SG 1000 PG 255	875.30.12	255	4 to 65	4 to 65	15000	7.70	30
	SG 1000 PG 340	875.30.13	340	4 to 65	4 to 65	15000	7.88	30
	SG 1000 PG 425	875.30.14	425	4 to 65	4 to 65	15000	7.99	30
	SG 1000 PG 510	875.30.15	510	4 to 65	4 to 65	15000	8.06	30
	SG 1000 PG 595	875.30.16	595	4 to 65	4 to 65	15000	8.12	30
DOUBLE POSITRACK 100% RUBBER	SGDP 1000 PG 170	875.59.11	170	4 to 65	4 to 65	15000	7.34	30
	SGDP 1000 PG 255	875.59.12	255	4 to 65	4 to 65	15000	7.70	30
	SGDP 1000 PG 340	875.59.13	340	4 to 65	4 to 65	15000	7.88	30
	SGDP 1000 PG 425	875.59.14	425	4 to 65	4 to 65	15000	7.99	30
	SGDP 1000 PG 510	875.59.15	510	4 to 65	4 to 65	15000	8.06	30
	SGDP 1000 PG 595	875.59.16	595	4 to 65	4 to 65	15000	8.12	30
SGDP 1000 PG 680	875.59.17	680	4 to 65	4 to 65	15000	8.16	30	

1" Pitch.

For information on tolerances for specified belt widths, please contact our Technical Support department.

Wider belts available on request.

The 1005 modular conveyor belt is multifunctional and suitable for heavy duty applications, such as conveying heavy PET bottles and glass bottles.



HEAVY DUTY SUGAR SACKS CONVEYOR WITH PLASTIC 1005-SERIES BELT.

BENEFITS

- High strength**
This is the strongest 1" pitch belt available.
- Extended wearlife**
In glass environments this belt will give less wear. The self cleaning pin construction is designed to avoid accumulation of dirt.
- Revolutionary assembly**
The belt can be opened very quickly by rotating the red Easy Locks with a screwdriver, without removing them from the belt.
- No preference in drive direction**
Suitable for bi-directional use.
- Fixed sprocket positions**
This makes assembly easier, improves the drive and means standardisation in conveyor construction, because the position is identical to that in standard chain conveyors.

PROGRAMME

- Flat Top (FT)**
Closed surface.
- Flat Top with Positrack (FTDP)**
This Positrack system consists of two guiding lugs on one side, which means precise transfer possibilities.
- Flat Top with integrated FreeFlow and Positrack (FFTDP)**
FreeFlow offers smooth 90° transfers for continuous product flow.

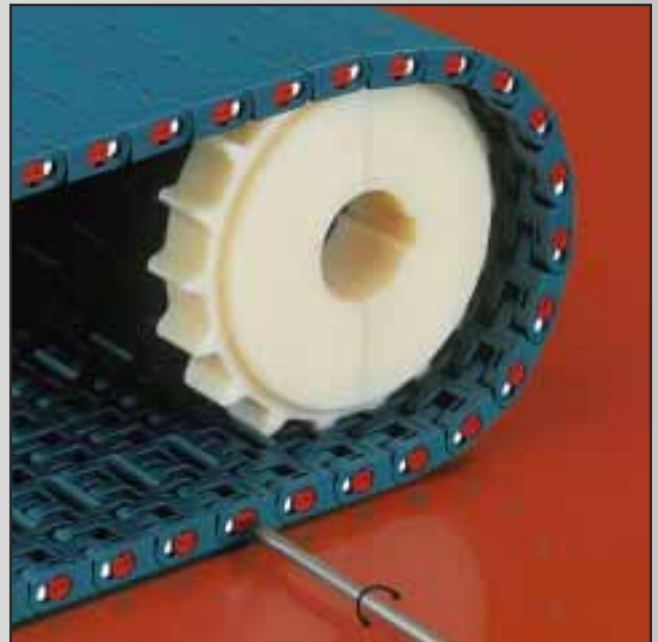

REVOLUTIONARY EASY LOCKS AND FIXED SPROCKET POSITIONS.

AND . . .

The material used for 1005 heavy duty belts is green-blue, extra low friction XLG-polyacetal. Also available is the XP-polypropylene, among other reasons for better chemical resistance.

1005-SERIES HEAVY DUTY BELTS

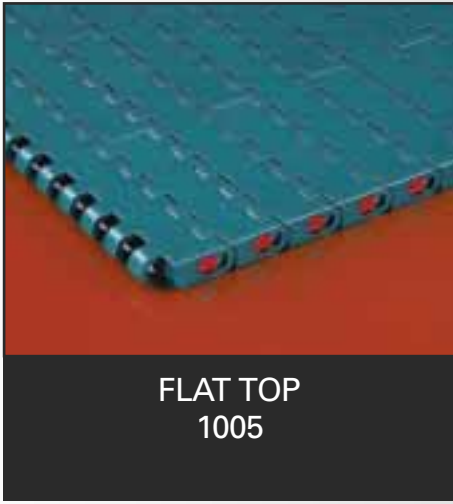

**FLAT TOP
1005**

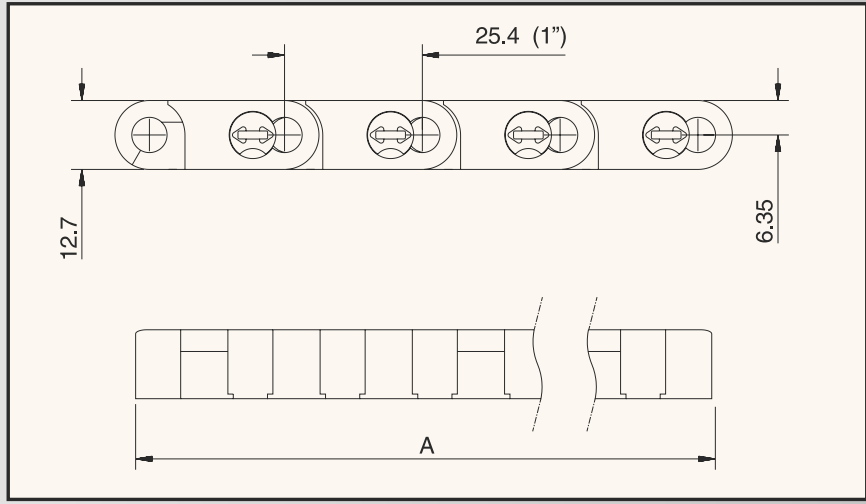

MATERIAL

page 158



page 132, 133

Assembly	Belt type	Code nr. last two digits depending on width A	Temp. range dry	Temp. range wet	Working load (max.) N/m (21°C)	Weight kg/m ²	Backflex radius (min.) mm
			°C	°C			
XLG-MATERIAL (POLYACETAL, GREEN-BLUE)							
STANDARD	FT 1005 XLG 85	877.00.10	4 to 80	4 to 65	35000	13.50	25
	FT 1005 XLG 6120	877.00.81					
DOUBLE POSITRACK (ONE SIDE)	FTDP 1005 XLG 85	877.01.10	4 to 80	4 to 65	35000	13.50	25
	FTDP 1005 XLG 6120	877.01.81					
DOUBLE POSITRACK (ONE SIDE) INTEGRATED FREEFLOW	FFTDP 1005 XLG 85	877.02.10	4 to 80	4 to 65	35000	13.50	25
	FFTDP 1005 XLG 6120	877.02.81					
XP-MATERIAL (POLYPROPYLENE)							
STANDARD	FT 1005 XP 85	877.05.10	4 to 104	4 to 104	17500	13.50	25
DOUBLE POSITRACK (ONE SIDE)	FT 1005 XP 6120	877.05.81	4 to 104	4 to 104	17500	13.50	25
	FTDP 1005 XP 85	877.06.10					
	FTDP 1005 XP 6120	877.06.81					

1" Pitch.

Standard length for belts up to a width of 680 mm: 3.048 m - 10 feet. Wider belts available in any length.

For information on tolerances for specified belt widths, please contact our Technical Support department.

Code nrs.: xx.xx.10 up to xx.xx.81 for widths 85 up to 6120, steps 85 mm.

For a listing of the last two digits in the code numbers for every belt width, please refer to the table on page 37.

The double Positrack lugs are positioned on one side of the belt for precise transfer possibilities.

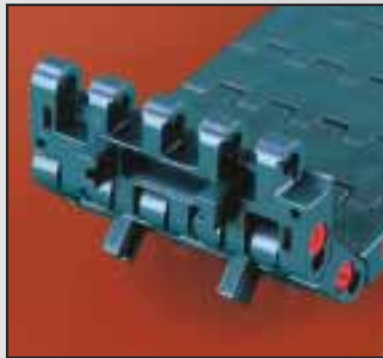

FLAT TOP 1005 HEAVY DUTY BELT WITH POSITRACK

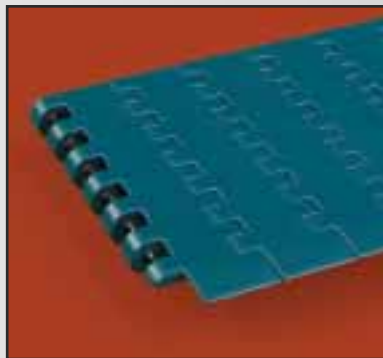
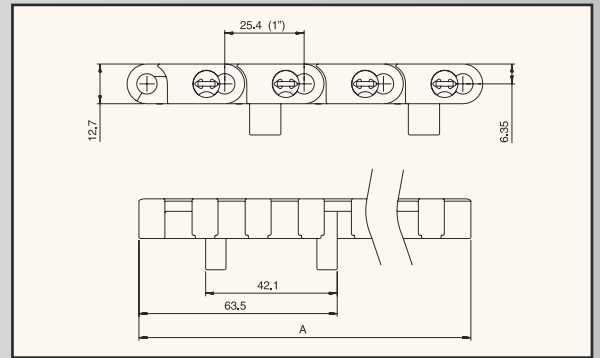

FLAT TOP 1005 HEAVY DUTY BELT WITH INTEGRATED FREEFLOW

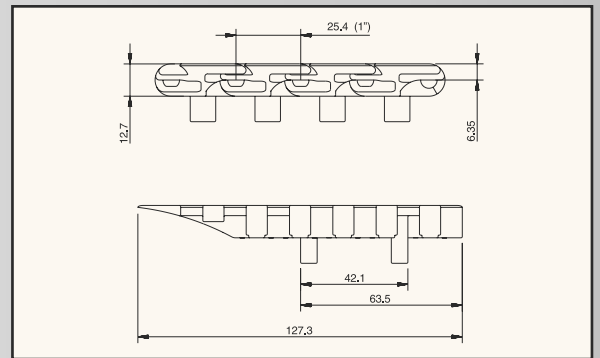

The 1005 Low Backline Pressure modular conveyor belt is suitable for low noise transport on long conveyors of multipack cans, 4- and 6-packs, trays, shrink-wrapped petaloid bottles and many other heavy duty applications.



SMOOTH 4-PACKS CONVEYOR WITH PLASTIC 1005-SERIES LBP BELT.

BENEFITS

- Minimum Backline Pressure**
The materials chosen and the accurate shape of pin and rollers give the lowest possible backline pressure.
- Low noise**
The material and design of the accumulation rollers also guarantee quiet operation.
- Optimum product stability**
The large number of rollers and the smart design result in the best possible product support. Due to the modular design, you can build wide tables with rollers over the entire width.
- Long wearlife**
High quality ensures a long wearlife with a lasting low friction.
- High maximum working load and all other advantages of 1005-series**
The strength of this robust belt is even higher than that of slatband LBP chains. The revolutionary pin retention by means of the red Easy Locks, bi-directional use and fixed sprocket positions are also worth mentioning.

PROGRAMME

- Without Positrack (LBP)**
Available in standard widths with 85 mm increments.
- With Positrack (LBPDP)**
2 Guiding lugs on one side underneath the belt will always keep the belt in position.



LARGE PACKS HANDLED WITH CARE ON QUIET 1005 LBP BELT.

AND . . .

The material of the 1005 heavy duty LBP belts is anthracite, extra low-friction XLA-polyacetal. The rollers are made of aubergine-coloured, special wear-resistant and sound-absorbing plastic.

1005-SERIES HEAVY DUTY LBP BELTS



LBP
1005

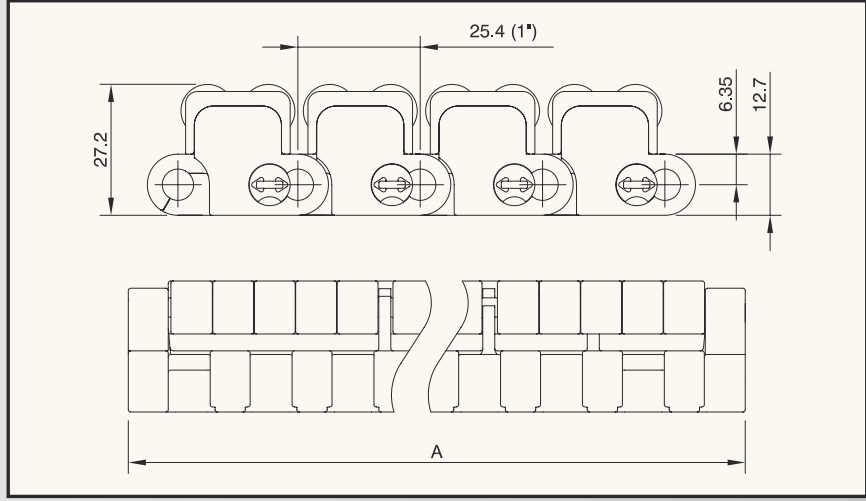

MATERIAL
page 158

page 132, 133

Assembly	Belt type	Code nr. last two digits depending on width A	Temp. range dry	Temp. range wet	Working load (max.) N/m (21°C)	Weight kg/m ²	Backflex radius (min.) mm
			°C	°C			
XLA-MATERIAL (POLYACETAL, ANTHRACITE)							
STANDARD	LBP 1005 XLA 170	877.03.11	4 to 80	4 to 65	35000	30	300
	LBP 1005 XLA 6120	877.03.81					
DOUBLE POSITRACK (ONE SIDE)	LBPDP 1005 XLA 170	877.04.11	4 to 80	4 to 65	35000	30	300
	LBPDP 1005 XLA 6120	877.04.81					

1" Pitch.

Standard length for belts up to a width of 680 mm: 1.524 m - 5 feet. Wider belts available in any length.

For information on tolerances for specified belt widths or Positrack, please contact our Technical Support department.

The double Positrack lugs are positioned on one side of the belt.

Code nrs.: xx.xx.11 up to xx.xx.81 for widths 170 up to 6120, steps 85 mm.

For a listing of the last two digits in the code numbers, please refer to the table on page 37.



1005 HEAVY DUTY LBP BELT WITH POSITRACK

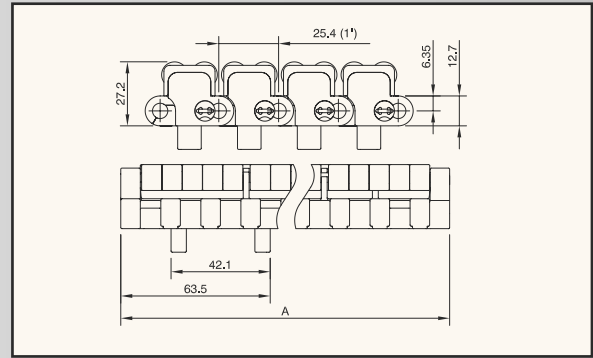

The 1005 SuperGrip plastic modular conveyor belt is suitable for inclined and declined heavy duty applications, like conveying crates with glass bottles or packs with heavy PET bottles.



INCLINED CRATE CONVEYOR WITH HEAVY DUTY SUPERGRIP BELT.

BENEFITS

- 100% secure bonding**
The state-of-the-art moulding process guarantees excellent chemical bonding.
- Extended wearlife**
Pad design, self-cleaning hinge construction and quality of both rubber and belt give this belt a long life.
- Inclines and declines up to 20°**
Adequate for most applications. The actual angle that can be used depends on product and circumstances. If you have doubts, please ask our Technical Support department.
- High maximum working load and all other advantages of 1005-series**
The strength of this robust belt is even higher than that of slatband chains and standard 1000-series belts. The revolutionary pin retention by means of the red Easy Locks, bi-directional use and fixed sprocket positions are also worth mentioning.

PROGRAMME

- SuperGrip (SG)**
Full belt width covered with rubber.
- SuperGrip with Positrack (SGDP)**
Full belt width covered with rubber; two Positrack guiding lugs on one side of the belt will keep the belt in position.
- SuperGrip Side-indent (SGS)**
Partially covered with rubber; both edges of the belt clear of rubber.
- SuperGrip Side-indent with Positrack (SGSDP)**
Partially covered with rubber, both edges of the belt clear of rubber; two Positrack guiding lugs on one side of the belt.



HEAVY TRAYS ON SIDE-INDENT 1005 SUPERGRIP BELT.

AND . . .

The material of 1005 heavy duty SuperGrip belts is green-blue PBT. Also available is the XP-polypropylene, among other reasons for better chemical resistance. The rubber coverage is 100%; other percentages can be supplied upon request.

1005-SERIES HEAVY DUTY SUPERGRIP BELTS

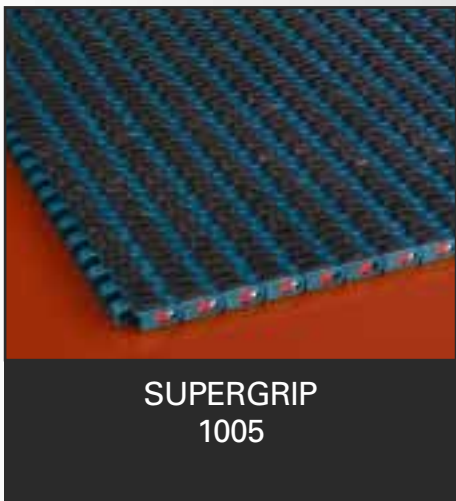

**SUPERGRIP
1005**

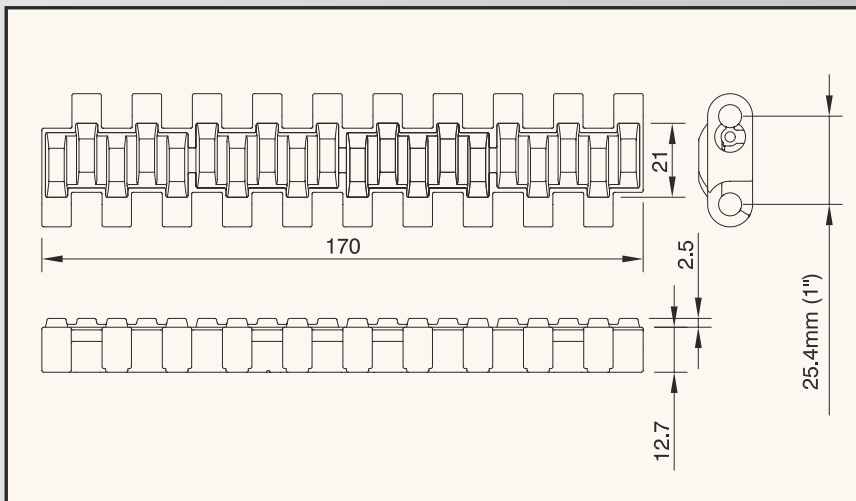

MATERIAL
page 158

page 132, 133

Assembly	Belt type	Code nr. last two digits depending on width	Temp. range dry	Temp. range wet	Working load (max.) N/m (21°C)	Weight kg/m ²	Backflex radius (min.) mm
			°C	°C			
PG-MATERIAL (PBT, GREEN-BLUE)							
STANDARD 100% RUBBER	SG 1005 PG 170	877.50.11	4 to 65	4 to 65	28000	13.30	25
	SG 1005 PG 6120	877.50.81					
DOUBLE POSITRACK (ONE SIDE) 100% RUBBER	SGDP 1005 PG 170	877.51.11	4 to 65	4 to 65	28000	13.30	25
	SGDP 1005 PG 6120	877.51.81					
XP-MATERIAL (POLYPROPYLENE)							
STANDARD 100% RUBBER	SG 1005 XP 170	877.64.11	4 to 65	4 to 65	17500	13.50	25
	SG 1005 XP 6120	877.64.81					
DOUBLE POSITRACK (ONE SIDE) 100% RUBBER	SGDP 1005 XP 170	877.66.11	4 to 65	4 to 65	17500	13.50	25
	SGDP 1005 XP 6120	877.66.81					

1" Pitch.

Standard length for belts up to a width of 680 mm: 3.048 m - 10 feet. Wider belts available in any length.

For information on tolerances for specified belt widths or Positrack, please contact our Technical Support department.

The double Positrack lugs are positioned on one side of the belt.

Code nrs.: xx.xx.11 up to xx.xx.81 for widths 170 up to 6120, steps 85 mm.

For a listing of the last two digits in the code numbers, please refer to the table on page 37.

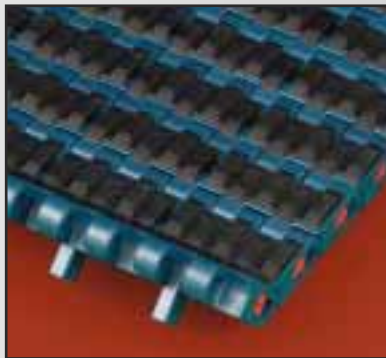

1005 HEAVY DUTY SUPERGRIP BELT WITH POSITRACK

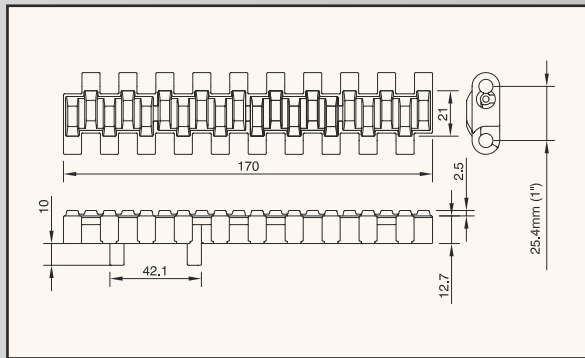

1005-SERIES HEAVY DUTY SUPERGRIP BELTS



**SUPERGRIP
SIDE-INDENT
1005**

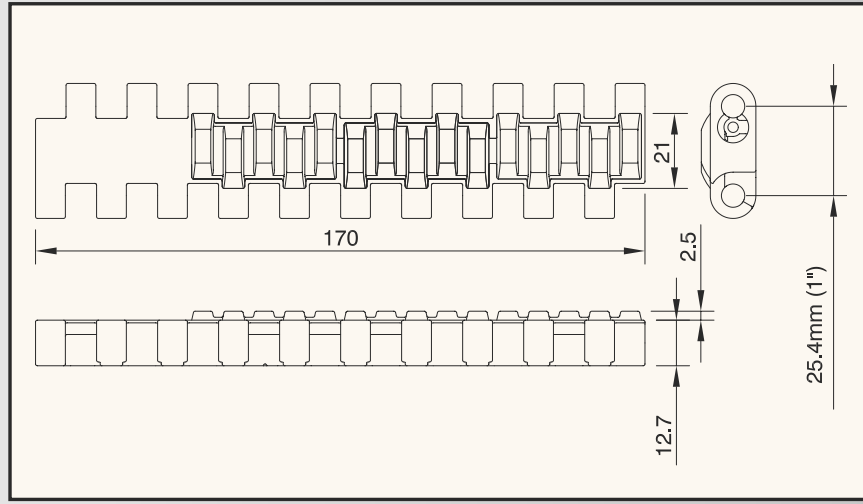

MATERIAL
page 158

page 132, 133

Assembly	Belt type	Code nr. last two digits depending on width	Temp. range dry	Temp. range wet	Working load (max.) N/m (21°C)	Weight kg/m ²	Backflex radius (min.) mm
			°C	°C			
PG-MATERIAL (PBT, GREEN-BLUE)							
STANDARD 100% RUBBER	SGS 1005 PG 255	877.52.12	4 to 65	4 to 65	28000	13.30	25
	SGS 1005 PG 6120	877.52.81					
DOUBLE POSITRACK (ONE SIDE) 100% RUBBER	SGSDP 1005 PG 255	877.53.12	4 to 65	4 to 65	28000	13.30	25
	SGSDP 1005 PG 6120	877.53.81					
XP-MATERIAL (POLYPROPYLENE)							
STANDARD 100% RUBBER	SGS 1005 XP 255	877.65.12	4 to 65	4 to 65	17500	13.50	25
	SGS 1005 XP 6120	877.65.81					
DOUBLE POSITRACK (ONE SIDE) 100% RUBBER	SGSDP 1005 XP 255	877.67.12	4 to 65	4 to 65	17500	13.50	25
	SGSDP 1005 XP 6120	877.67.81					

1" Pitch.

Standard length for belts up to a width of 680 mm: 3.048 m - 10 feet. Wider belts available in any length.

For information on tolerances for specified belt widths or Positrack, please contact our Technical Support department.

The double Positrack lugs are positioned on one side of the belt.

Code nrs.: xx.xx.12 up to xx.xx.81 for widths 255 up to 6120, steps 85 mm.

For a listing of the last two digits in the code numbers, please refer to the table on page 37.

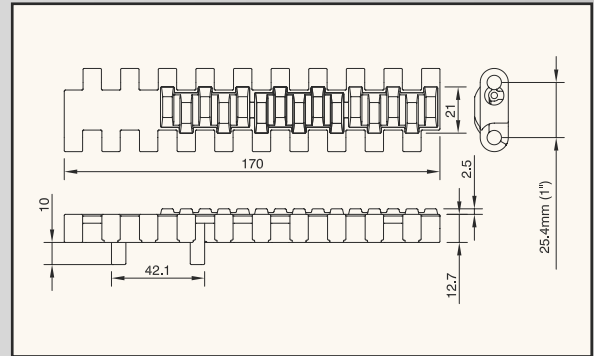
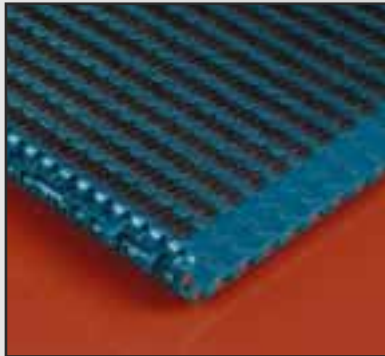

1005-SERIES SUPERGRIP SIDE-INDENT BELT WITH POSITRACK

The 2000-series belt is made for heavy duty applications. The pitch is 2 inch.



BOTTLE CONVEYOR WITH PLASTIC 2000-SERIES BELT.

BENEFITS

- Heavy duty drive**
 The heavy duty positive drive construction provides optimum belt engagement and an extended wearlife. The belt is fully supported by the sprocket.
- Perfect product handling**
 Surface flatness and design provide optimum product support. Together with the finger plates, 2000-series Raised Rib belts ensure trouble-free transfer of products onto and from the belt.
- Easy installation and maintenance**
 The pin retention clips at the sides can easily be fitted and removed.

PROGRAMME

- Flush Grid**
 The 31% open area of Flush Grid (FG) belts guarantee an optimum flow of water, dirt and air; at the same time the large support area gives good product support and a long wearlife. They are suitable for large 3-piece cans and are also used in the food and automotive industry.
- Flat Top**
 The closed surface makes Flat Top (FT) belts suitable for large, odd-shaped products.
- Raised Rib**
 The 30% open area of Raised Ribs (RR) combined with a maximum support area and optimum temperature (up to 104°C) and chemical resistance make these belts ideal for (double deck) pasteurizers, warmers and coolers; they are also used for large accumulation tables. Positrack (RRP) is possible.
- Raised Rib Heavy Duty**
 A reinforced yellow Raised Rib belt (RRHD), intended for one-way glass and dual purpose (can/glass) applications. The open area is 27%. Positrack (RRHDP) is possible.

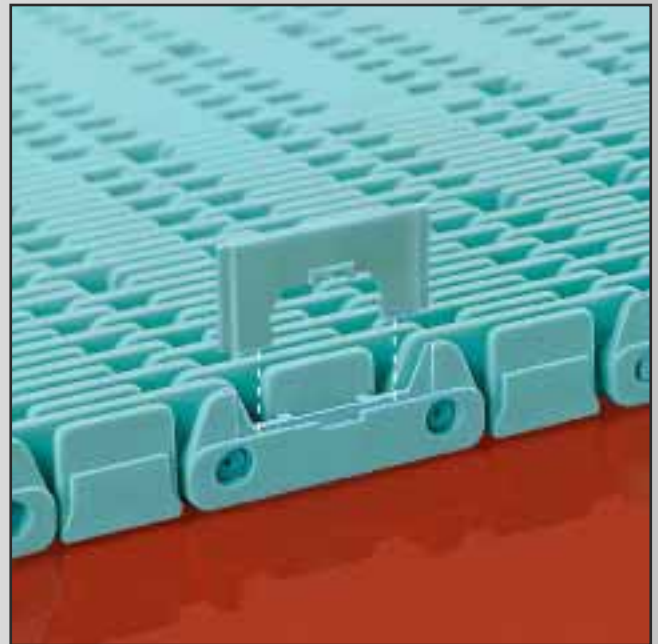

NICE PIN RETENTION CLIPS FOR EASY INSTALLATION AND MAINTENANCE OF THE BELT.

AND . . .

2000-Series belts are mostly made of light green, wear-resistant XP-polypropylene. The 2000-series belts are always tailor-made.

2000-SERIES MODULAR CONVEYOR BELTS



**FLUSH GRID
2000**

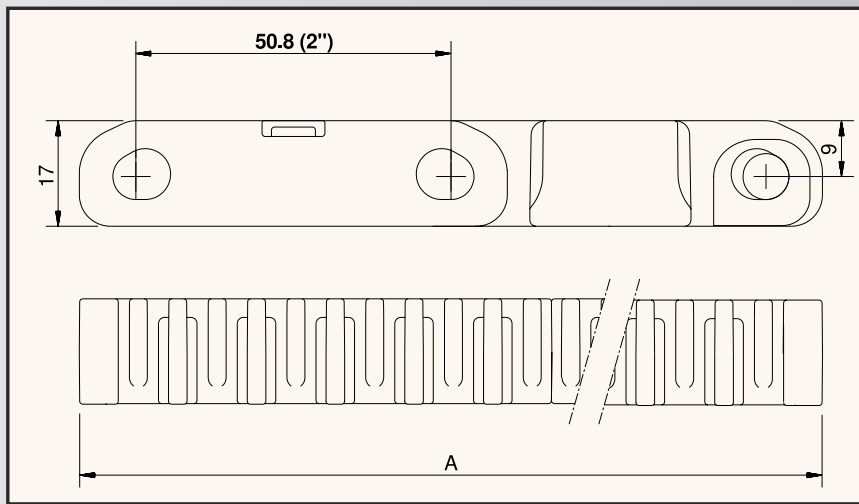

Assembly	Belt type	Code nr. last two digits depending on width A	Temp. range dry	Temp. range wet	Working load (max.) N/m (21°C)	Weight kg/m ²	Backflex radius (min.) mm
			°C	°C			
XP-MATERIAL (POLYPROPYLENE, LIGHT-GREEN)							
STANDARD	FG 2000 XP 3	838.40.10	4 to 104	4 to 104	29500	7.55	35
	FG 2000 XP 240	838.40.89					

2" Pitch.

For information on tolerances for specified belt widths, please contact our Technical Support department.

Code nrs.: xx.xx.10 up to xx.xx.89 for widths 3" up to 240", steps 3".

For a listing of the last two digits in the code numbers for every belt width, please refer to the table on page 37.



**FLAT TOP
2000**

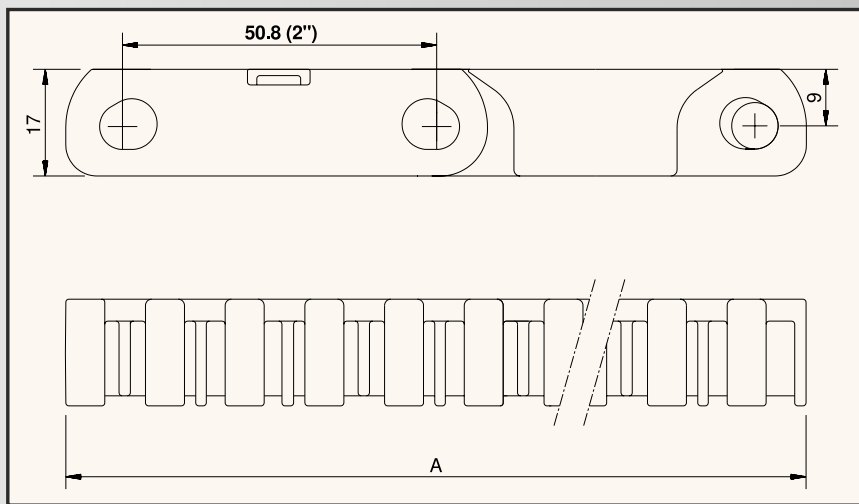

Assembly	Belt type	Code nr. last two digits depending on width A	Temp. range dry	Temp. range wet	Working load (max.) N/m (21°C)	Weight kg/m ²	Backflex radius (min.) mm
			°C	°C			
XP-MATERIAL (POLYPROPYLENE, LIGHT-GREEN)							
STANDARD	FT 2000 XP 3	838.30.10	4 to 104	4 to 104	29500	8.20	45
	FT 2000 XP 240	838.30.89					

2" Pitch.

For information on tolerances for specified belt widths, please contact our Technical Support department.

Code nrs.: xx.xx.10 up to xx.xx.89 for widths 3" up to 240", steps 3".

For a listing of the last two digits in the code numbers for every belt width, please refer to the table on page 37.

2000-SERIES MODULAR CONVEYOR BELTS



**RAISED RIB
2000**

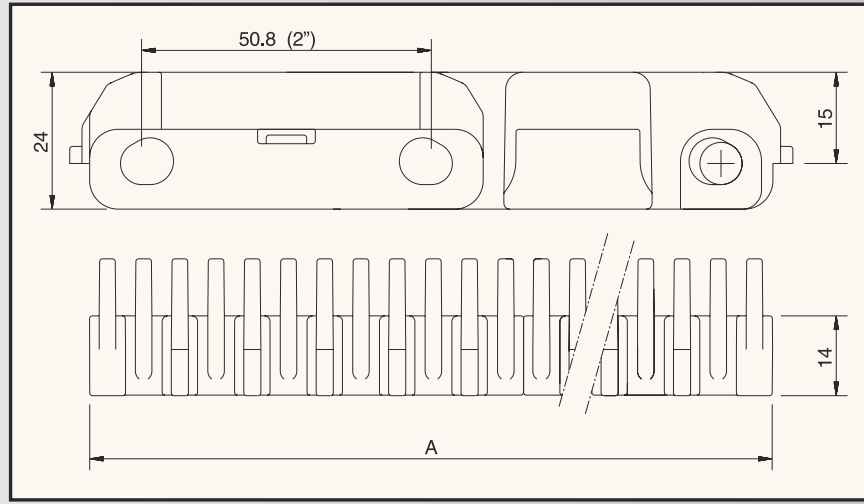

Assembly	Belt type	Code nr. last two digits depending on width A	Temp. range dry	Temp. range wet	Working load (max.) N/m (21°C)	Weight kg/m ²	Backflex radius (min.) mm
			°C	°C			
XP-MATERIAL (POLYPROPYLENE, LIGHT-GREEN)							
STANDARD	RR 2000 XP 3	838.10.10	4 to 104	4 to 104	29500	10.60	75
	RR 2000 XP 240	838.10.89					
CENTER POSITRACK	RRP 2000 XP 9	838.90.12	4 to 104	4 to 104	29500	10.60	75
	RRP 2000 XP 240	838.90.89					

2" Pitch.

For information on tolerances for specified belt widths, please contact our Technical Support department.

The double Positrack lugs in the center of the belt ensure its precise positioning.

Code nrs.: xx.xx.10 up to xx.xx.89 for widths 3" up to 240", steps 3".

For a listing of the last two digits in the code numbers for every belt width, please refer to the table on page 37.



RAISED RIB 2000 BELT WITH POSITRACK

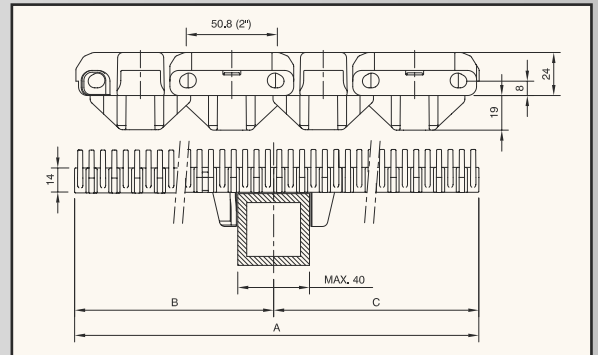

2000-SERIES MODULAR CONVEYOR BELTS



**RAISED RIB
2000
HEAVY DUTY**

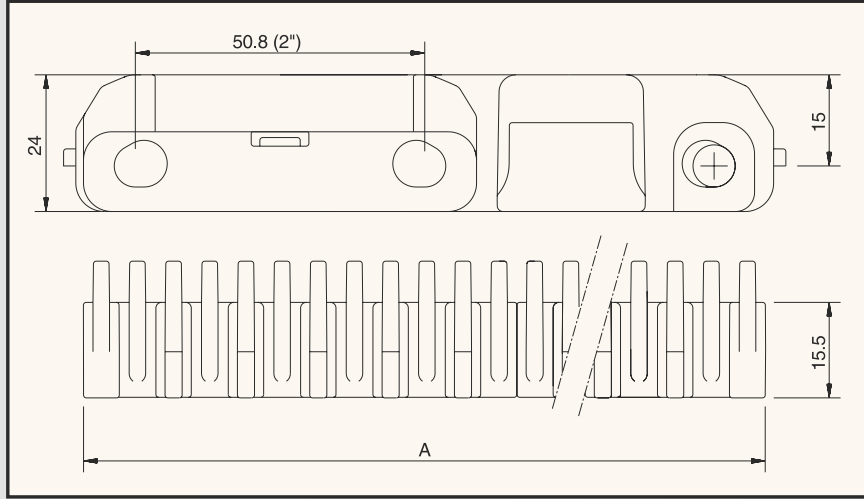

Assembly	Belt type	Code nr. last two digits depending on width A	Temp. range dry	Temp. range wet	Working load (max.) N/m (21°C)	Weight kg/m ²	Backflex radius (min.) mm
			°C	°C			
YP-MATERIAL (POLYPROPYLENE, YELLOW)							
STANDARD	RRHD 2000 YP 3	880.60.10	4 to 104	4 to 104	29500	11.20	75
	RRHD 2000 YP 240	880.60.89					
CENTER POSITRACK	RRHDP 2000 YP 9	880.90.12	4 to 104	4 to 104	29500	11.20	75
	RRHDP 2000 YP 240	880.90.89					

2" Pitch.

For information on tolerances for specified belt widths, please contact our Technical Support department.

The double Positrack lugs in the center of the belt ensure its precise positioning.

Code nrs.: xx.xx.10 up to xx.xx.89 for widths 3" up to 240", steps 3".

For a listing of the last two digits in the code numbers for every belt width, please refer to the table on page 37.



RAISED RIB 2000 HEAVY DUTY BELT WITH POSITRACK

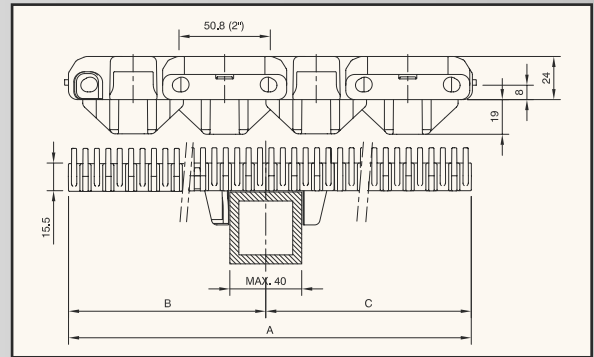

The 2500-series modular conveyor belt is especially made for use in heavy duty conditions: long, heavily loaded pasteurizers for glass bottles.



HEAVILY LOADED GLASS PASTEURIZER OUTFEED WITH PLASTIC 2500-SERIES BELT.

BENEFITS

- Resistance to broken glass**
The total system, the module design, the transfer fingers, the free space between the belt and finger block have been designed to cope with broken glass and to get rid of it.
- Superior product handling**
Even unstable glass bottles and jars transfer smoothly from the belt onto the outfeed conveyor by means of transfer fingers in a transfer block, which can slide and follow the expansion and contraction of the belt.
- High strength**
The belt has been designed for the enormous working load in long pasteurizers with large bottles.
- Easy maintenance**
Unlike walking beam systems, this system consists of only a small number of different parts. The Easy Locks make it simple to lock pins and to remove them again if necessary. (Dis)assembly of the belt is much easier than with wire mesh belts. The revolutionary finger transfer system makes it very easy and cheap to replace a finger. Only split sprockets are used for easy and quick replacement.

PROGRAMME

- Solid Rib (SR)**
Open area of 20%, tested to handle 30 m³/m²/hour when full with bottles.
- Solid Rib with Positrack (SRP)**
The double Positrack lugs in the center of the belt ensure its precise positioning.



EASY LOCKS FOR SIMPLE INSTALLATION AND MAINTENANCE.

AND . . .

2500-Series glass pasteurizer belts are made of yellow glass-reinforced polypropylene; the transfer fingers are of the same material in green-blue.

2500-SERIES GLASS PASTEURIZER BELTS



**SOLID RIB
2500**

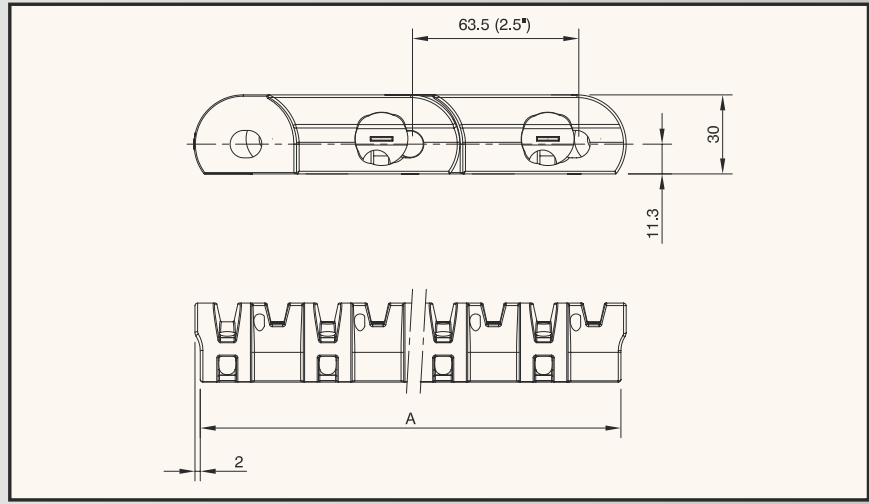

Assembly	Belt type	Code nr. last two digits depending on width A	Temp. range dry	Temp. range wet	Working load (max.) N/m (21°C)	Weight kg/m ²	Backflex radius (min.) mm
			°C	°C			
YPR-MATERIAL (REINFORCED POLYPROPYLENE, YELLOW)							
STANDARD	SR 2500 YPR 18	832.70.15	4 to 104	4 to 104	47500	18.50	75
	SR 2500 YPR 240	832.70.89					
CENTER POSITRACK	SRP 2500 YPR 18	832.80.15	4 to 104	4 to 104	47500	18.50	75
	SRP 2500 YPR 240	832.80.89					

2.5" Pitch.

MCC 2500-series belts are always tailor-made upon request.

For information on tolerances for specified belt widths, please contact our Technical Support department.

The double Positrack lugs in the center of the belt ensure its precise positioning.

Code nrs.: xx.xx.15 up to xx.xx.89 for widths 18" up to 240", steps 3".

For a listing of the last two digits in the code numbers for every belt width please refer to the table on page 37.



SOLID RIB 2500 BELT WITH POSITRACK

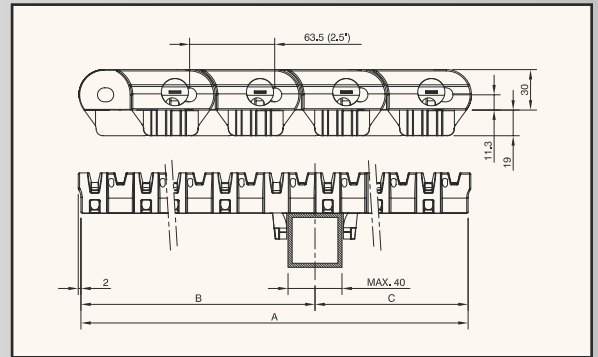

505, 1255 and 7956 flexbelts are predominantly suitable for sideflexing transport of packages and clustered products, such as shrink-wrapped products and 4- and 6-packs. The 505 has a 0.5 inch pitch, the smallest available in the world; the 1255 and 7956 have a 1.25 inch pitch, for heavier products.



SIDEFLEXING AEROSOL CAN CONVEYOR WITH 505-SERIES PLASTIC FLEXBELT.

BENEFITS

- Excellent guiding**
Due to the shape of the belts, supported by Positrack lugs and cleverly shaped strips in the 505 and 1255 and by hold-down tabs in the 7956, the flexbelts offer optimum guiding possibilities both in curves and on straight sections. Even S-curves are possible.
- Optimum use of space**
The inside radius of the belts can be as small as two times the width, reducing the required space.
- Superior product handling**
The surface design with small gaps and the minimal cordal action result in the best possible stability of the products.
- Easy installation and maintenance**
The belts can be fitted and removed in a few seconds.
- Fewer drives**
With all these belts, you do not only cover the bend, but you can also extend the conveyor by adding straight sections, thus saving drives.

PROGRAMME

- 505 Radius belt with Positrack (RBP)**
To create a continuous product flow, even of small, unstable products. Open area is 10%.
- 1255 Radius belt with Positrack (RBP)**
The most versatile belt, combining relatively small transfers with a high working load. Open area is 39%.
- 7956 Radius belt with Tabs (RBT)**
For large and heavy products. Open area is 16%.



SHRINK-WRAPPED BOTTLES ON 1255-SERIES FLEXBELT.

AND . . .

Flexbelts are made of green-blue, extra low-friction XLG-polyacetal. Ask our Application Consultants to calculate the best solution for your line.

505-SERIES FLEXBELTS



**RADIUS
505
WITH POSITRACK**

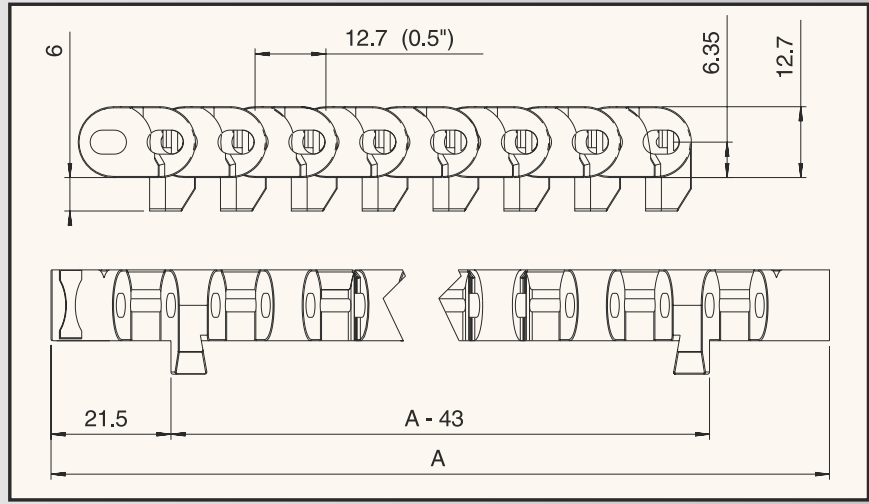

Assembly	Belt type	Code nr.	Width	Temp. range dry	Temp. range wet	Max. working load straight/ in curve (21°C)	Sideflex radius (min.)	Weight	Backflex radius (min.)
			A	°C	°C				
XLG-MATERIAL (POLYACETAL, GREEN-BLUE)									
POSITRACK TWO SIDES	RBP 505 XLG 255	867.30.12	255	4 to 80	4 to 65	3825 ; 1300	510	9	15
	RBP 505 XLG 340	867.30.13	340	4 to 80	4 to 65	5100 ; 1300	680	9	15
	RBP 505 XLG 425	867.30.14	425	4 to 80	4 to 65	6375 ; 1300	850	9	15
	RBP 505 XLG 510	867.30.15	510	4 to 80	4 to 65	7650 ; 1300	1020	9	15
	RBP 505 XLG 595	867.30.16	595	4 to 80	4 to 65	8925 ; 1300	1190	9	15
	RBP 505 XLG 680	867.30.17	680	4 to 80	4 to 65	10200 ; 1300	1360	9	15

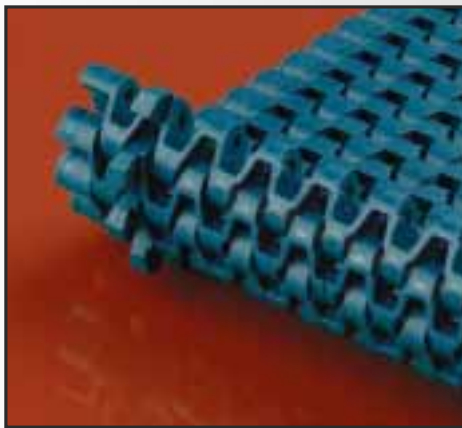

STANDARD POSITRACK LUGS ON BOTH SIDES

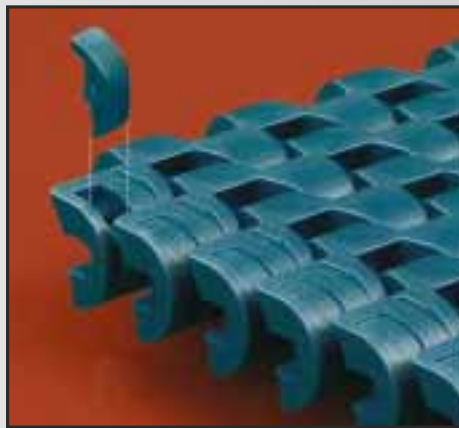

PIN RETENTION CLIPS FOR EASY (DIS)ASSEMBLY

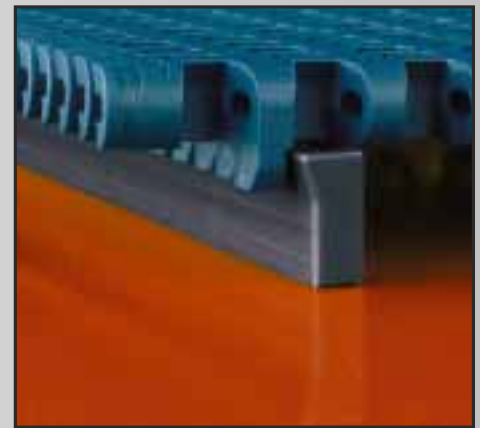

CURVE GUIDING PROFILE FOR 505

0.5" Pitch.

Double Positrack guiding lugs in combination with cleverly shaped strips ensure positioning of the belt in the curve.

The sideflex radius is measured on the inside of the belt.

The belt can be supplied from stock in standard lengths of 10 feet (3.048 m) in widths from 255 up to 680 mm; wider belts will be tailor-made on request.

The pins are locked by means of retention clips.

The curve guiding profile for the 505 has a standard length of 2 meters; it is made of MCC 3500 special polyamide, code nr. 800.00.01.

For straight sections the same construction can be used as for the 500-, 1000- and 1005-series, ideal for standardisation in conveyor design.

For 505-series flexbelts you can order a complete tab curve; for details see page 109.

1255-SERIES FLEXBELTS

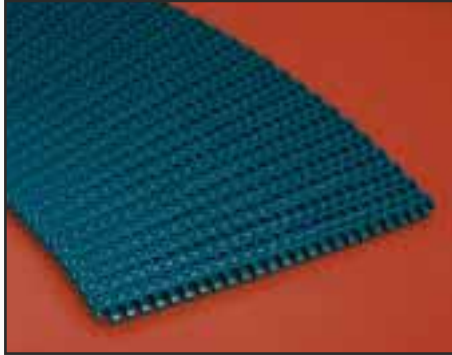

**RADIUS
1255
WITH POSITRACK**

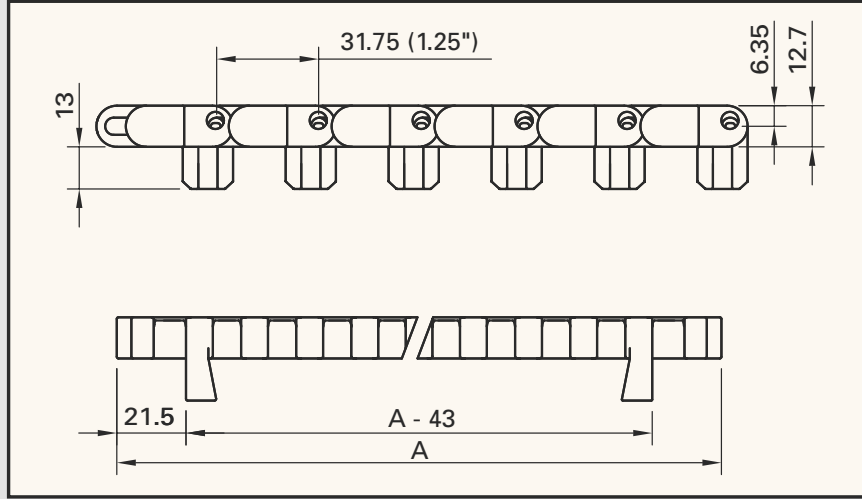

Assembly	Belt type	Code nr.	Width	Temp. range dry	Temp. range wet	Max. working load (21°C) straight; in curve	Sideflex radius (min.)	Weight	Backflex radius (min.)
			A	°C	°C				
XLG-MATERIAL (POLYACETAL, GREEN-BLUE)									
POSITRACK TWO SIDES	RBP 1255 XLG 255	867.40.12	255	4 to 80	4 to 65	5610 ; 2000	510	8	25
	RBP 1255 XLG 340	867.40.13	340	4 to 80	4 to 65	7480 ; 2000	680	8	25
	RBP 1255 XLG 425	867.40.14	425	4 to 80	4 to 65	9350 ; 2000	850	8	25
	RBP 1255 XLG 510	867.40.15	510	4 to 80	4 to 65	11220 ; 2000	1020	8	25
	RBP 1255 XLG 595	867.40.16	595	4 to 80	4 to 65	13090 ; 2000	1190	8	25
	RBP 1255 XLG 680	867.40.17	680	4 to 80	4 to 65	14960 ; 2000	1360	8	25
SUPERGRIP									
POSITRACK TWO SIDES	SG 1255 XLG 340	867.54.13	340	4 to 65	4 to 65	7480 ; 2000	680	8	30
	SG 1255 XLG 425	867.54.14	425	4 to 65	4 to 65	9350 ; 2000	850	8	30
	SG 1255 XLG 510	867.54.15	510	4 to 65	4 to 65	11220 ; 2000	1020	8	30
	SG 1255 XLG 595	867.54.16	595	4 to 65	4 to 65	13090 ; 2000	1190	8	30
	SG 1255 XLG 680	867.54.17	680	4 to 65	4 to 65	14960 ; 2000	1360	8	30

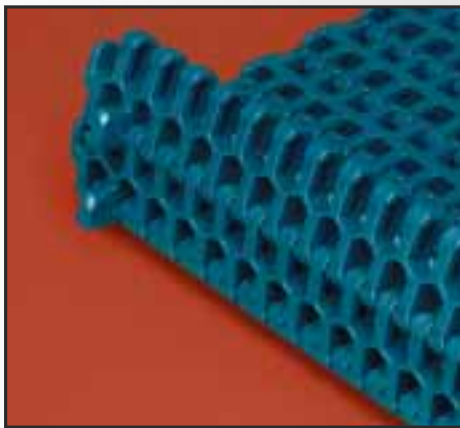

STANDARD POSITRACK LUGS ON BOTH SIDES

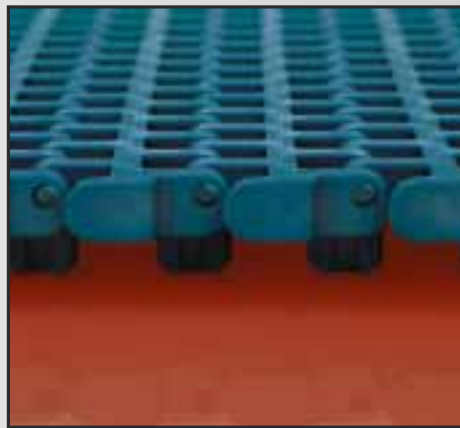

PIN RETENTION BY ECCENTRIC HINGE EYES

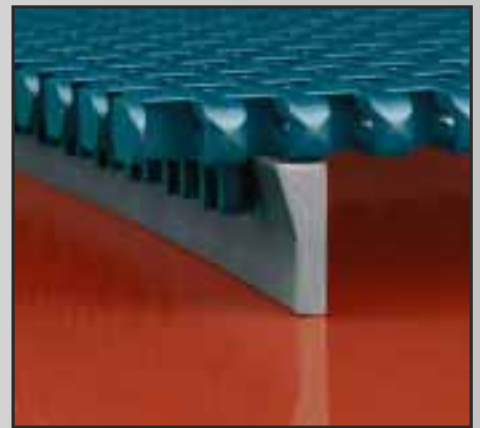

CURVE GUIDING PROFILE FOR 1255

1.25" Pitch.

Double Positrack guiding lugs in combination with cleverly shaped strips ensure positioning of the belt in the curve.

The sideflex radius is measured on the inside of the belt.

The belt can be supplied from stock in standard lengths of 10 feet (3.048 m) in widths from 255 up to 680 mm; wider belts will be tailor-made on request.

The curve guiding profile for the 1255 has a standard length of 1.80 meters; it is made of MCC 3500 special polyamide, code nr. 800.00.10.

For straight sections the same construction can be used as for the 500-, 1000- and 1005-series, ideal for standardisation in conveyor design.

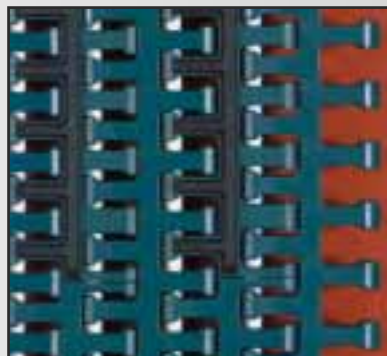

SUPERGRIP FOR INCLINED CONVEYING

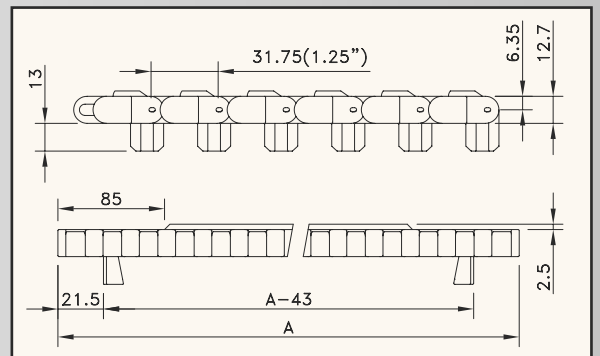

For 1255-series flexbelts you can order a complete tab curve; for details see page 109.

For 1255 SuperGrip other rubber patterns are possible, such as the pitch of the rubber coverage and the length of the side-indent.

7956-SERIES FLEXBELTS

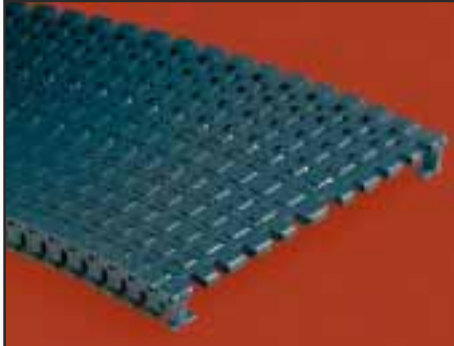

**RADIUS
7956
WITH TABS**

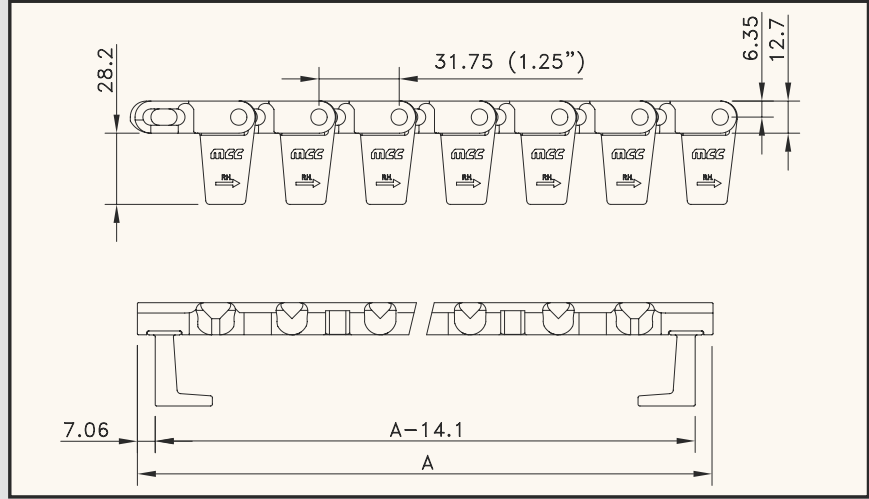

Assembly	Belt type	Code nr.	Width	Temp. range dry	Temp. range wet	Max. working load (21°C) straight; in curve	Sideflex radius (min.)	Weight	Backflex radius (min.)
			inch	°C	°C	N	inch	kg/m ²	mm
XLG-MATERIAL (POLYACETAL, GREEN-BLUE)									
TABS TWO SIDES	RBT 7956 XLG 6	81421431	6	4 to 80	4 to 65	2000 ; 2000	12	11.60	50
	RBT 7956 XLG 15	81421441	15	4 to 80	4 to 65	4000 ; 4000	30	11.60	50
	RBT 7956 XLG 18	81427431	18	4 to 80	4 to 65	4225 ; 4225	36	11.60	50
	RBT 7956 XLG 24	81421451	24	4 to 80	4 to 65	5300 ; 5300	48	11.60	50

RBT 7956 XLG 30 (width 30") will be released by the end of 2003.

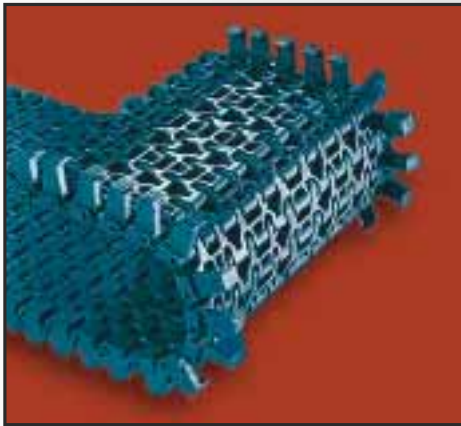

STANDARD HOLD-DOWN TABS

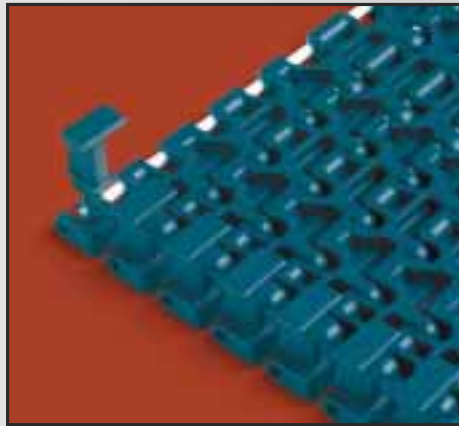

PIN RETENTION BY TABS FOR EASY (DIS)ASSEMBLY



APPLICATION OF 7956-SERIES FLEXBELT

1.25" Pitch.

Hold-down tabs on both sides ensure positioning of the belt in the curve.

The sideflex radius is measured on the inside of the belt.

The belt can be supplied from stock in standard lengths of 10 feet (3.048 m) in widths of 6", 15", 18" and 24".

The tabs also take care of the pin retention.

The tabs offer possibilities for slight inclines.

MCC MAGNETFLEX® CHAINBELT SYSTEM

The plastic Magnetflex® chainbelt system is the revolution for sideflex conveyors. This unique system consists of Magnetflex® chainbelts and Magnetflex® curves. It has been designed for use in combination with the MCC 1000- and 1005-series of modular plastic belts.



SIDEFLEXING CAN CONVEYOR WITH PLASTIC MAGNETFLEX® 1050 CHAINBELT.

BENEFITS

- Optimum product flow**
The unique top plate design and 1 inch pitch provide a maximum support area and excellent transfers, even in small radii.
- High strength**
The material and design of the hinge ensure a high working load.
- Standardisation in conveyor construction**
The thickness of the chainbelts corresponds with the MCC 1000- and 1005-series, thus enabling standardisation in conveyor construction.
- Extended life**
Because of the solidity of the 1055-series, this chainbelt will allow for a longer life in glass environments.
- All well known advantages of the Magnetflex® system**
Easy installation, cleaning and maintenance and flat carrying surface.

PROGRAMME

- FGM 1050 Flush Grid Magnetflex®**
With 15% open area, mainly for cans and champagne-base pet bottles.
- FTM 1050 Flat Top Magnetflex®**
With closed top, for one-way glass and most petaloid bottles.
- FTM 1055 Flat Top Magnetflex®**
With closed top, for heavy duty applications, such as glass bottles and heavy pet bottles.

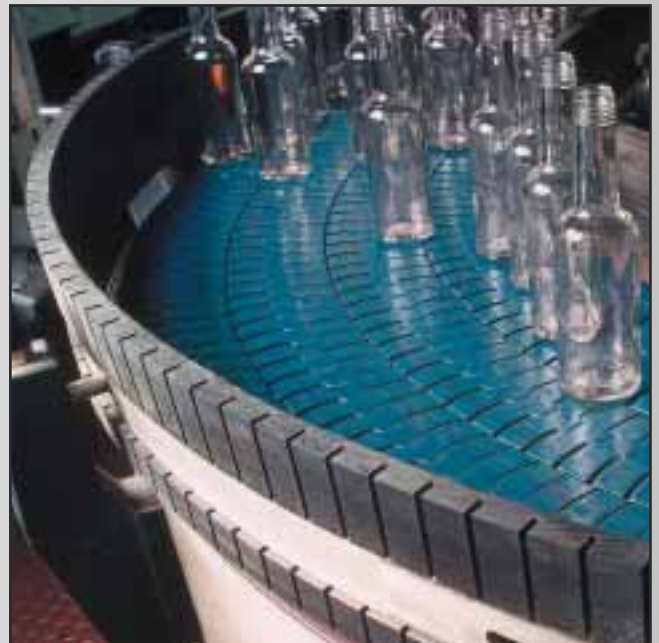

HEAVY DUTY APPLICATION OF 1055 CHAINBELTS IN A GLASS FACTORY.

AND . . .

Both FGM and FTM 1050 are available in green-blue, extra low friction XLG-polyacetal and in aubergine XS-material, a state-of-the-art polyacetal, giving a much longer life, high PV limits and a continuous low friction.

1050-SERIES CHAINBELTS

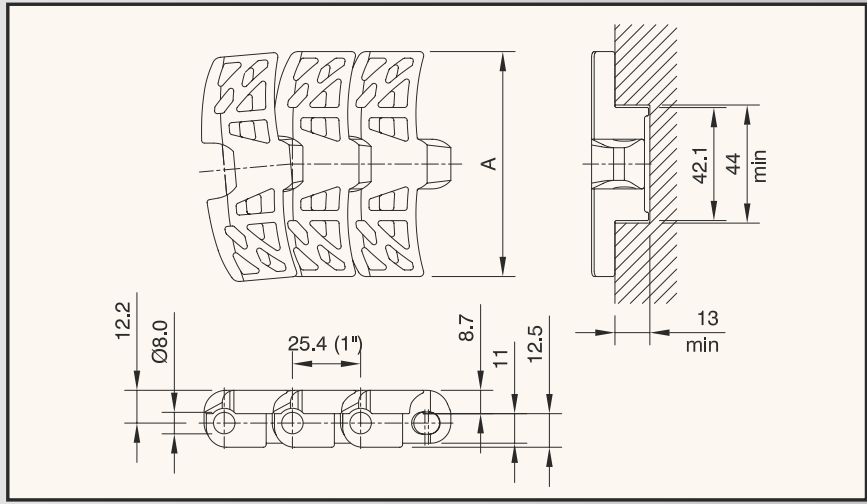

Chain type	Code nr.	Plate width		Working load (max.) N (21°C)	Backflex radius (min.) mm	Sideflex radius (min.) mm	Plate thickness mm	Weight kg/m
		A mm	inch					
XLG-MATERIAL (POLYACETAL, GREEN-BLUE)								
FGM 1050 XLG	749.11.31	83.8	3.30	1650	130	500	8.7	1.54
XS-MATERIAL (POLYACETAL, AUBERGINE)								
FGM 1050 XS	749.16.31	83.8	3.30	1650	130	500	8.7	1.54

Standard length: 3.048 m - 10 feet (120 links).

1050-SERIES CHAINBELTS



FLAT TOP MAGNETFLEX®
1050

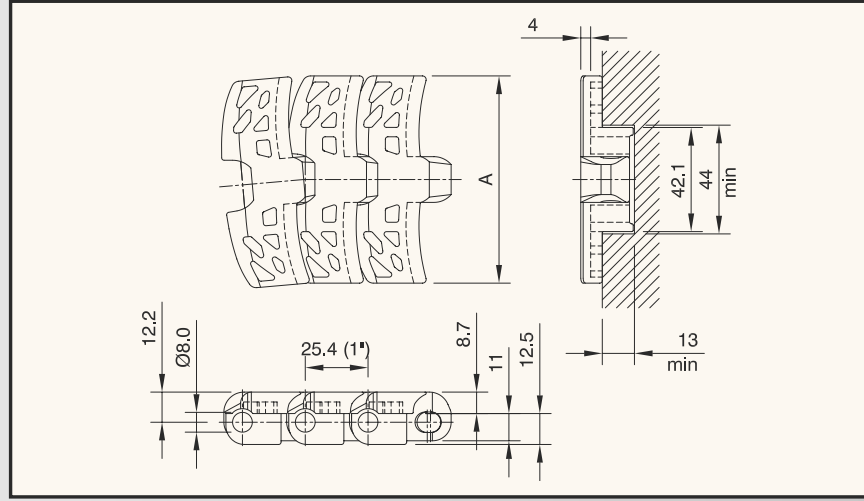

Chain type	Code nr.	Plate width		Working load (max.) N (21°C)	Backflex radius (min.) mm	Sideflex radius (min.) mm	Plate thickness mm	Weight kg/m
		A mm	A inch					
XLG-MATERIAL (POLYACETAL, GREEN-BLUE)								
FTM 1050 XLG	749.21.31	83.8	3.30	1650	130	500	8.7	1.68
XS-MATERIAL (POLYACETAL, AUBERGINE)								
FTM 1050 XS	749.26.31	83.8	3.30	1650	130	500	8.7	1.68

Standard length: 3.048 m - 10 feet (120 links).

1055-SERIES CHAINBELTS



FLAT TOP MAGNETFLEX®
1055
HEAVY DUTY

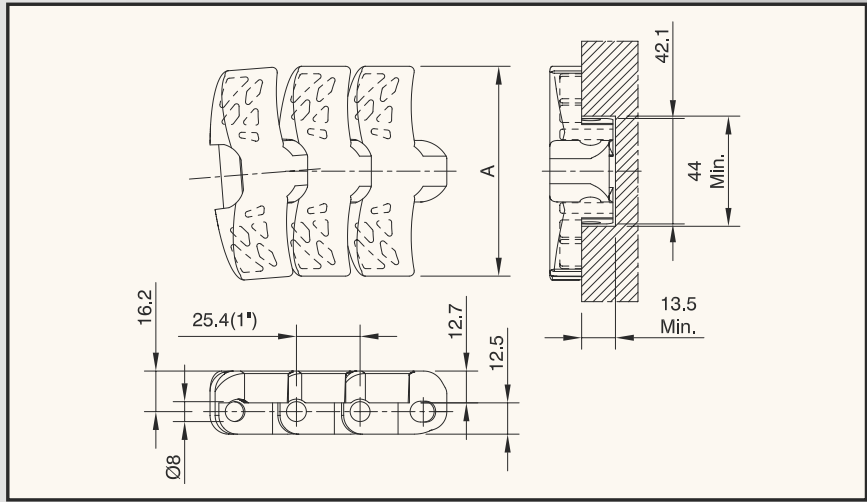

Chain type	Code nr.	Plate width		Working load (max.) N (21°C)	Backflex radius (min.) mm	Sideflex radius (min.) mm	Plate thickness mm	Weight kg/m
		A mm	A inch					
XLG-MATERIAL (POLYACETAL, GREEN-BLUE)								
FTM 1055 XLG K330	749.41.31	83.8	3.30	2200	130	500	12.7	1.90
FTM 1055 XLG K450	749.41.42	114.3	4.50	2200	130	500	12.7	2.20

Standard length: 3.048 m - 10 feet (120 links).

mcc FINGER TRANSFERS

The finger plate ensures trouble-free transfer of products to and from the belt.



SMOOTH BOTTLE TRANSFER WITH PLASTIC CLICK-COMB FINGERPLATES.

BENEFITS

- Time saving**
The click-fit system for the 1000- and 2000-series makes it easy to install and remove the fingers, as you will see on the picture below. The system for the 2500 glass pasteurizer belt makes it possible to remove the single fingers.
- No special installation instructions for high or low temperatures**
This system follows any belt expansion or contraction, without the limitations of shoulder screw mounting.

PROGRAMME

- Fingerplates for 1000-series Raised Rib belts**
Available in green-blue, extra low friction XLG-polyacetal and in black AS-polyacetal, anti-static material.
- Click-Comb fingerplates for 2000-series Raised Rib belts standard**
Long fingers for optimum can transfer; available in green-blue, extra low friction XLG-polyacetal.
- Click-Comb fingerplates for 2000-series Raised Rib belts for glass handling applications**
Shorter fingers, designed to cope with broken glass; available in green-blue, extra low friction XLG-polyacetal.
- DTS®-C system for pasteurizers and accumulation tables**
This brand new Dynamic Transfer System – Comb improves self-clearing of the infeed and discharge to and from a 2" Raised Rib belt in pasteurizers, warmers and coolers; available in super tough thermal and chemical resistant material. To be combined with RR(P) 2000 XP or RRHD(P) 2000 YP and the FFTP 1005 XLG on a Marbett wearstrip (41 mm).
- Finger transfer system for 2500-series glass pasteurizer belts**
Long, separate fingers to handle broken glass even better; available in green-blue, glass-reinforced polypropylene.

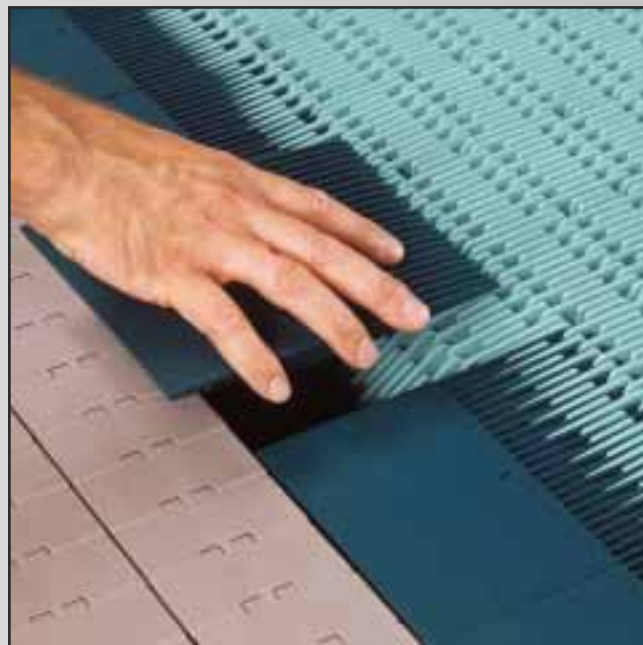

TIME-SAVING SYSTEM TO INSTALL FINGER TRANSFERS.

AND . . .

The finger plates click on to stainless steel profiles, also supplied by Rexnord; these are different for the 1000- and 2000-series. For the 2500-series there's a special profile in which the fingers can be locked. All profiles can easily be cut to fit your construction.

FINGER TRANSFERS



**CLICK-COMB FINGERPLATES
FOR 1000-SERIES
RAISED RIB**

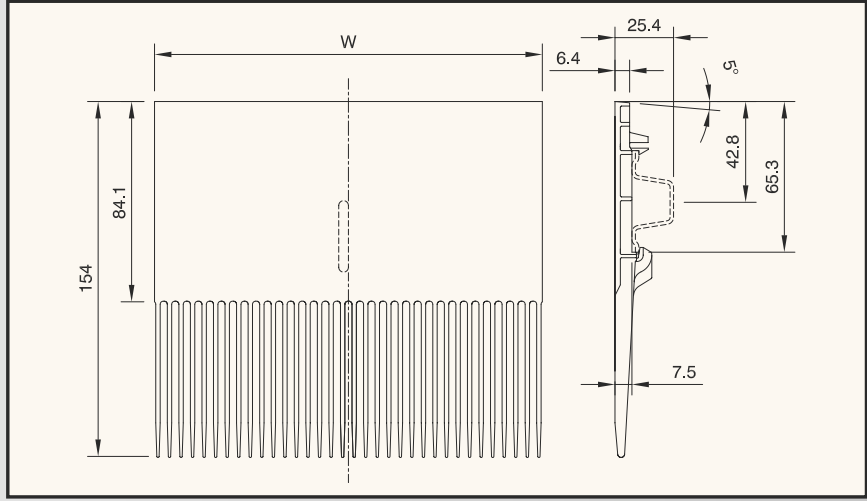

'Click-Comb' fingerplate type	Code nr.	Length	Width W	Weight ≈
		mm	mm	kg
XLG-MATERIAL				
1000 XLG 154 x 170	817.12.05	154	168	0.14
1000 XLG 154 x 85	817.12.04	154	83	0.07
AS-MATERIAL				
1000 AS 154 x 170	814.12.05	154	168	0.13
1000 AS 154 x 85	814.12.04	154	83	0.06



**FINGERPLATES
FOR 1000-SERIES
RAISED RIB NARROW**

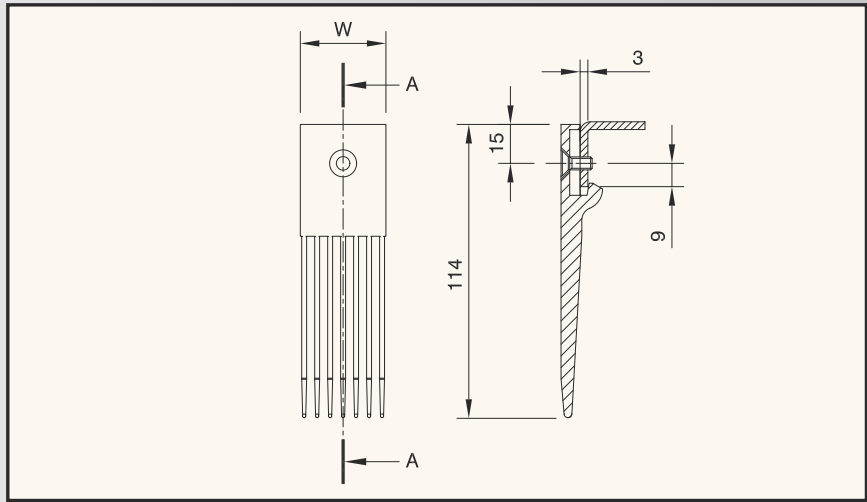

Fingerplate type	Code nr.	Length	Width W	Weight ≈
		mm	mm	kg
XLG-MATERIAL				
1000 XLG 114 x 23	817.12.13	114	23	0.01
1000 XLG 114 x 33	817.12.10	114	33	0.02
1000 XLG 114 x 43	817.12.11	114	43	0.02
1000 XLG 114 x 53	817.12.12	114	53	0.03

FINGER TRANSFERS

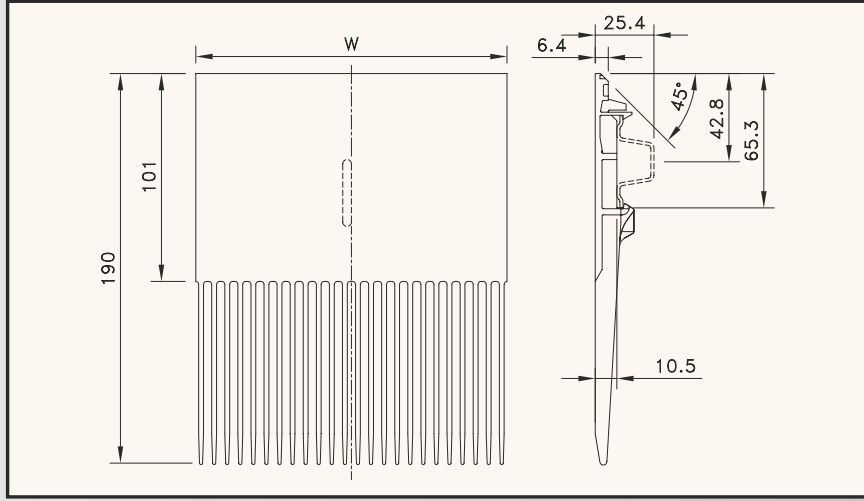
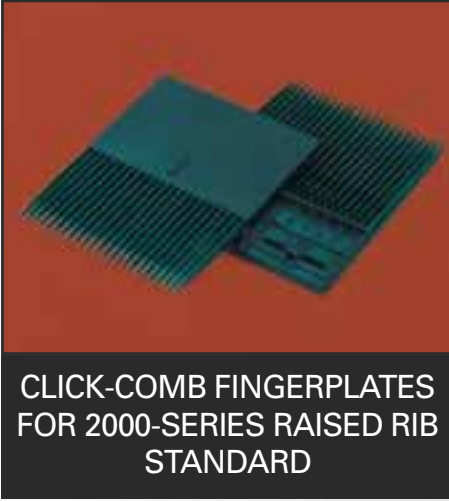

 page 58, 59

 page 73

MATERIAL
page 158

'Click-Comb' fingerplate type	Code nr.	Length	Width W	Weight ≈
		mm	mm	kg
XLG-MATERIAL				
2000 XLG 190 x 152	837.12.01	190	151	0.16
2000 XLG 190 x 76	837.12.02	190	74	0.08

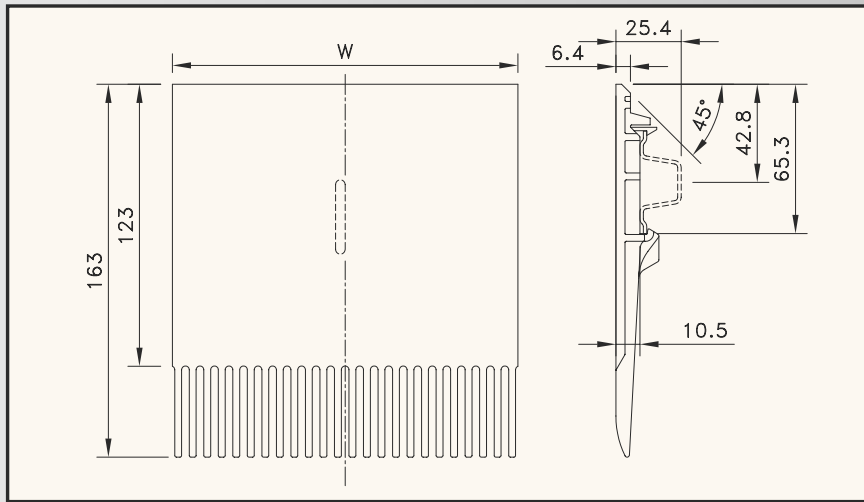

 page 58, 59

 page 73

MATERIAL
page 158

'Click-Comb' fingerplate type	Code nr.	Length	Width W	Weight ≈
		mm	mm	kg
XLG-MATERIAL				
GL 2000 XLG 163 x 152	837.12.09	163.1	151	0.16
GL 2000 XLG 163 x 76	837.12.03	163.1	74	0.08

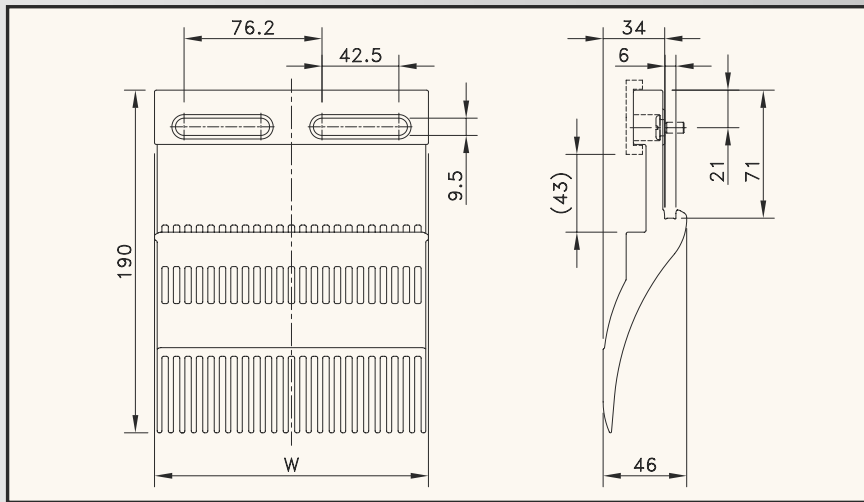

 page 58, 59

MATERIAL
page 158

Product	Code nr.	Length	Width W	Weight ≈
		mm	mm	kg
REINFORCED POLYAMIDE				
DTS-C 2000-1005 190 x 152	834.12.79	190	151	0.25

FINGER TRANSFERS



**FINGER TRANSFER SYSTEM
FOR 2500-SERIES GLASS
PASTEURIZER BELTS**

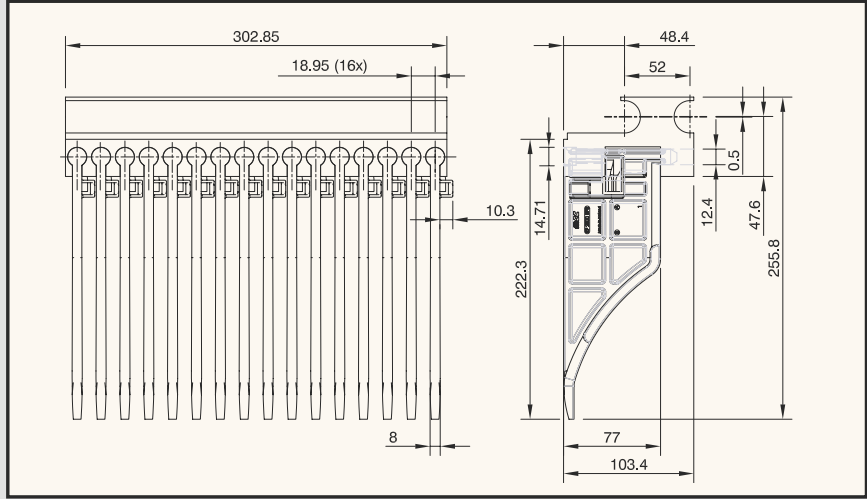

page 61

MATERIAL
page 158

Product	Code nr.	Width	Length	Weight ≈
		mm	mm	kg
BPR-POLYPROPYLENE				
MC 2500 mounting-block incl. 16 fingers	834.72.61	304.4	255.8	1.71
Mounting-block	801.57.01	304.4	63.0	0.85
RF 2500 BPR exchange set of 16 fingers	834.72.51	-	-	0.54



**PROFILES FOR
CLICK-COMB
FINGERPLATES**

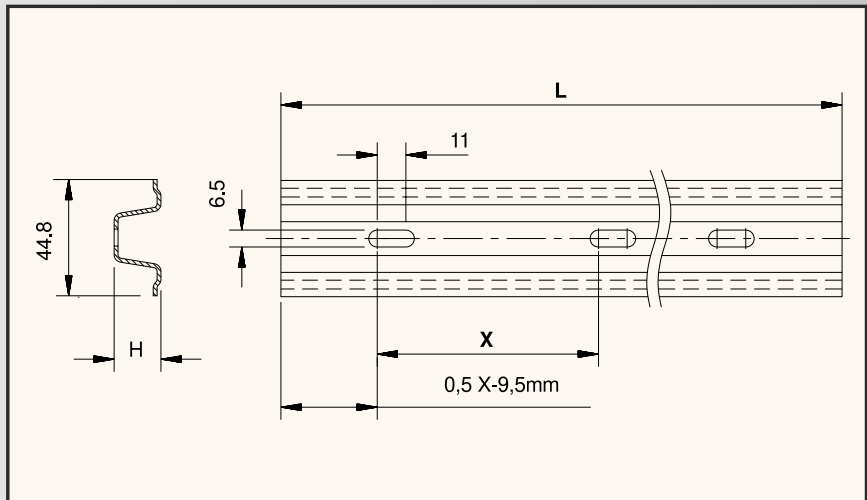

page 43, 58, 59

page 71, 72

MATERIAL
page 158

For Click-Comb fingerplate type	Code nr.	Height H	Number of itches	Length L	Pitch X		For belt width mm	Weight kg
		mm		mm	mm	inch		
FOR 1000-SERIES RAISED RIB BELTS								
1000 XLG	801.55.10	18	7	672	85.0	3.35	0 < W ≤ 595	0.54
	801.55.11	18	13	1182	85.0	3.35	595 < W ≤ 1105	0.95
	801.55.13	18	19	1692	85.0	3.35	1105 < W ≤ 1615	1.35
	801.55.14	18	25	2202	85.0	3.35	1615 < W ≤ 2125	1.76
	801.55.16	18	31	2712	85.0	3.35	2125 < W ≤ 2635	2.17
	801.55.19	18	43	3732	85.0	3.35	2635 < W ≤ 3655	2.99
	801.55.22	18	55	4752	85.0	3.35	3655 < W ≤ 4675	3.80
	801.55.01	18	70	6027	85.0	3.35	4675 < W ≤ 5950	4.82
FOR 2000-SERIES RAISED RIB BELTS								
2000 XLG standard and GL 2000 XLG	801.55.28	15	7	602	76.2	3.00	0 < W ≤ 533	0.44
	801.55.29	15	13	1059	76.2	3.00	533 < W ≤ 991	0.77
	801.55.31	15	19	1516	76.2	3.00	991 < W ≤ 1448	1.11
	801.55.32	15	25	1973	76.2	3.00	1448 < W ≤ 1905	1.44
	801.55.34	15	31	2430	76.2	3.00	1905 < W ≤ 2362	1.77
	801.55.37	15	43	3345	76.2	3.00	2362 < W ≤ 3277	2.44
	801.55.40	15	55	4259	76.2	3.00	3277 < W ≤ 4191	3.11
	801.55.43	15	67	5174	76.2	3.00	4191 < W ≤ 5105	3.78
801.55.02	15	78	6012	76.2	3.00	5105 < W ≤ 5944	4.39	

The Magnetflex® Combi curve is the ideal solution for your corners. Special integrated permanent magnets keep the chain in the curve. This system has become the world-wide standard in the food and beverage industry, because it is the most reliable and cost-effective sideflex system, offering the best product support and product flow. Combi-A, distinguished by the colour aubergine, is MCC's standard curve.



CRATE CONVEYOR WITH SPACE-SAVING MAGNETFLEX® COMBI CURVE.

BENEFITS

- One standard conveyor construction**
As a combi system it can be used for (stainless) steel and plastic Magnetflex® chains and for the Magnetflex® chainbelts, using the same construction.
- Hygienic concept**
Cleaning the curve can be done easily by lifting the chain. The top design is closed and smooth to avoid dirt accumulation.
- Optimum product handling**
The chains are kept down in the curves by means of magnets; this results in a flat carrying surface, offering optimum product stability and support. Magnetflex® chains are also flatter since they have no integrated or welded-on tabs or bevels.
- Time saving**
The chain can be lifted out of the curve, which makes installation and maintenance very easy.
- Improved wearlife**
This system provides a longer wearlife, because the bearing surface of the chains on the curve is larger than in other systems, and maintenance is easier.

PROGRAMME

- Combi-A curve**
This aubergine coloured material is MCC's standard for Magnetflex®, suitable for most applications.
- Combi-G curve**
This green/yellow coloured material is for extremely abrasive conditions, such as a bottle-filler discharge, in combination with (stainless) steel slatband chains.
- Combi-S curve**
This sulphite-grey coloured material is for high-speed, dry running applications with plastic chain and chainbelt.
- Combi-L curve**
This light blue coloured material is for high PV limits, less friction, low noise and anti-static properties.
- CIP-curve**
This curve, with built-in tubes and nozzles, can be hooked up to an existing CIP-system, for easy cleaning and optimum hygiene.
- Tab curve**
This black curve is for plastic and stainless steel tab chains and for flexbelts.



COMBI-A (AUBERGINE), -G (GREEN/YELLOW), -S (SULPHITE GREY) AND -L (LIGHT BLUE) CURVE.

AND . . .

In practice these curves have proven to achieve better results than deadplate systems and conventional sideflex systems. The complete curve consists of an upper part with the magnets and a separate return part mounted together. If required, both parts can be installed individually. The return infeed shoe will ensure smooth guiding of the chains into the return section. The Magnetflex® Combi curves have been patented in a large number of countries. The aubergine colour is a trademark of Rexnord FlatTop Europe b.v.

Our Application Consultants will be happy to help you find the best choice for your application.

MAGNETFLEX® CURVES

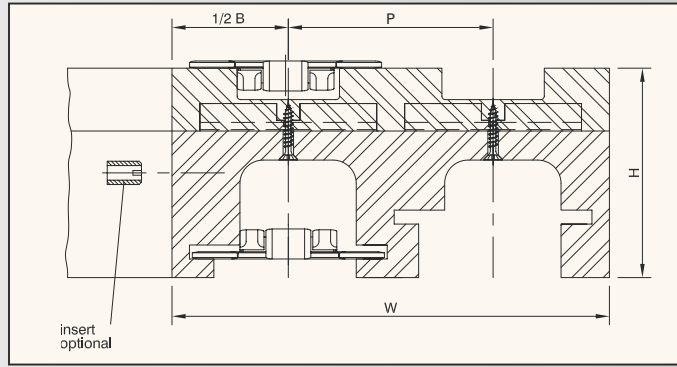
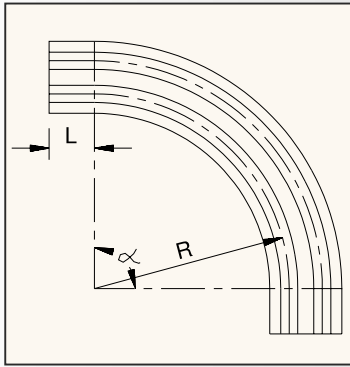

SELECTION TABLES

Select your curve by reading the tables from left to right. You'll find more information on the specified pages.

For chain type(s)	Radius	Pitch	Basic width	Infeed length	Total height	Version number	See page	
	R	P	B	L	H			
	mm	mm	mm	mm	mm			
FOR CHAINS WITH 3.25" PLATE WIDTH								
10 M 31 M	500	85	100	0	82 / 90	C7	83	
45 M 31 M				100	90	C6	82	
60 M 31 (S)M		111	100	100	90	C4	79	
60 M 31 RM				125	82	C1	76	
60 M 84 SM		90	100	100	82	C2	77	
RHM(D) 325 XL				0	82	C3	78	
RHM 325 AS		590	180	100	100	82	C5B	80
RHM 325 XS		680	-	100	100	82	C5A	80
RHM 84 XL		750	85	111	100	90	C42	87
		860	-	100	125	82	C5C	81
	1000	-	100	0	82	C5D	81	
		85	111	100	90	C43	88	
RHMD 325 LBP	500	90	100	100	90	LBP2	95	
10 M 31 M	500	85	111	100	100	CIP4	98	
45 M 31 M			100	100	100	100	CIP6	99
60 M 31 (S)M								
60 M 31 RM								
60 M 84 SM								
FOR CHAINS WITH 4.50" PLATE WIDTH								
10 M 42 M	500	120	129	125	90	C21A	84	
45 M 42 M	610	120	129	125	90	C22A	85	
60 M 42 M		117	129	0	90	C27	86	
RHM(D) 450 XL								
FOR CHAINS WITH 7.50" PLATE WIDTH								
10 M 72 M	610	196	214	125	90	C61	89	
60 M 72 M	860	-	214	0	82	C66	90	
60 M 72 RM	1000	-	214	0	82	C65	90	
HDFM 750 XL/SG	610	195	200	100	95	C81	91	
60 M 75 (R)M								
HDFM 750 XL/SG	860	-	214	0	87	C86	92	
60 M 75 (R)M								
HDFM 750 LBP	860	-	214	0	95	LBP861	96	
FOR CHAINS WITH 10.00" PLATE WIDTH								
HDFM 1000 XL/SG	860	-	290	0	87	C91	93	
HDFM 1000 LBP	860	-	290	0	95	LBP91	96	
FOR CHAINS WITH 12.00" PLATE WIDTH								
HDFM 1200 XL/SG	860	-	340	0	87	C96	94	
HDFM 1200 LBP	860	-	340	0	95	LBP96	97	
FOR CHAINBELTS								
FGM 1050 XLG/XS	500	85	100	0	82 / 90	CB7	102	
FTM 1050 XLG/XS				100	90	CB6	101	
				111	90	CB4	100	
				111	100	90	CC4	103
FTM 1055 XLG K330	500	85	100	100	90	CC6	104	
				100	82/90	CC7	105	
				0				
FTM 1055 XLG K450	500	120	129	125	90	CC21	106	
	610					CC22	107	

MAGNETFLEX® CURVES



**MAGNETFLEX®
COMBI-A
VERSION C1**

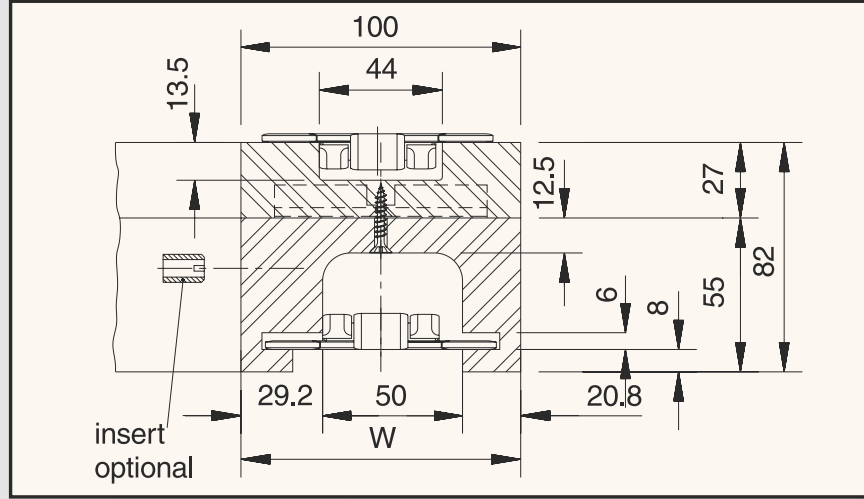

MATERIAL
page 159

page 17

page 6, 11

Angle	Code nr.	Width W
		mm
1 TRACK		
15°	704.05.16	100
30°	704.05.31	
45°	704.05.46	
60°	704.05.61	
75°	704.05.76	
90°	704.05.01	
2 TRACKS		
15°	704.05.17	189
30°	704.05.32	
45°	704.05.47	
60°	704.05.62	
75°	704.05.77	
90°	704.05.02	
3 TRACKS		
15°	704.05.18	278
30°	704.05.33	
45°	704.05.48	
60°	704.05.63	
75°	704.05.78	
90°	704.05.03	
4 TRACKS		
15°	704.05.19	367
30°	704.05.34	
45°	704.05.49	
60°	704.05.64	
75°	704.05.79	
90°	704.05.04	
5 TRACKS		
15°	704.05.20	456
30°	704.05.35	
45°	704.05.50	
60°	704.05.65	
75°	704.05.80	
90°	704.05.05	
6 TRACKS		
15°	704.05.21	545
30°	704.05.36	
45°	704.05.51	
60°	704.05.66	
75°	704.05.81	
90°	704.05.06	

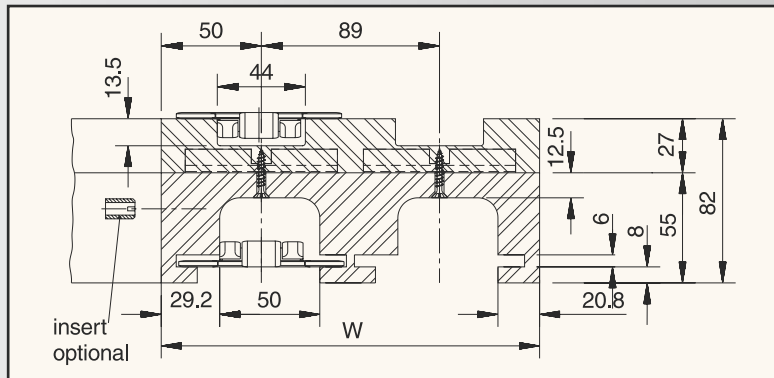

CURVE DIMENSIONS FOR MULTITRACK CURVES

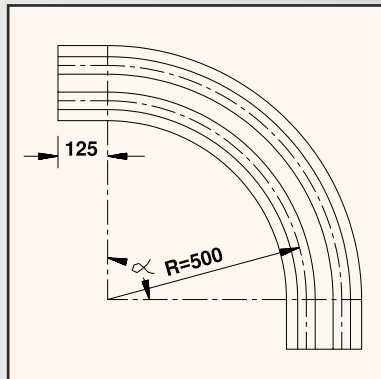

RADIUS

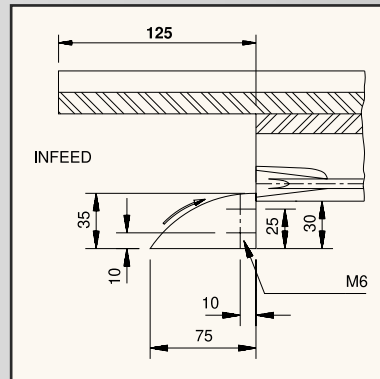

RETURN GUIDE SHOE

For (stainless) steel Magnetflex® chains, types:

- 10 M 31 M
- 45 M 31 M
- 60 M 31 (S)M
- 60 M 31 RM
- 60 M 84 SM

For plastic Magnetflex® chains, types:

- RHM 325 XL
- RHMD 325 XL
- RHM 325 AS
- RHM 325 XS
- RHM 84 XL

More than 6 tracks on request.

Magnetflex® curves can be supplied with M8 or M10 brass inserts to your detailed drawing.

A wide range of Magnetflex® curves with non-standard dimensions can be supplied.

Several Combi-G curves can be supplied for extremely abrasive applications.
 Several Combi-S curves can be supplied for high-speed applications.
 Several Combi-L curves can be supplied for noise reduction and high PV limits.
 Magnetflex® CIP-curves can be supplied for 'Cleaning In Place' (CIP) applications.

MAGNETFLEX® CURVES

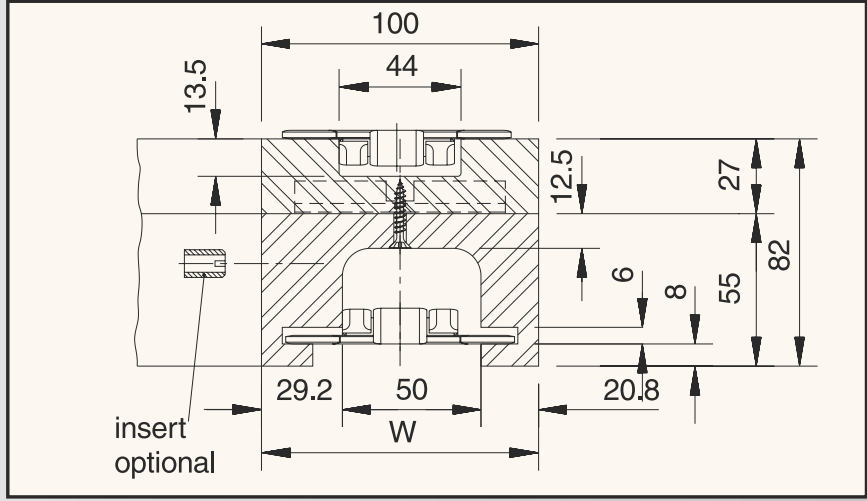

MATERIAL
page 159

page 17

page 6, 11

Angle	Code nr.	Width W
		mm
1 TRACK		
15°	704.06.16	100
30°	704.06.31	
45°	704.06.46	
60°	704.06.61	
75°	704.06.76	
90°	704.06.01	
2 TRACKS		
15°	704.06.17	190
30°	704.06.32	
45°	704.06.47	
60°	704.06.62	
75°	704.06.77	
90°	704.06.02	
3 TRACKS		
15°	704.06.18	280
30°	704.06.33	
45°	704.06.48	
60°	704.06.63	
75°	704.06.78	
90°	704.06.03	
4 TRACKS		
15°	704.06.19	370
30°	704.06.34	
45°	704.06.49	
60°	704.06.64	
75°	704.06.79	
90°	704.06.04	
5 TRACKS		
15°	704.06.20	460
30°	704.06.35	
45°	704.06.50	
60°	704.06.65	
75°	704.06.80	
90°	704.06.05	
6 TRACKS		
15°	704.06.21	550
30°	704.06.36	
45°	704.06.51	
60°	704.06.66	
75°	704.06.81	
90°	704.06.06	

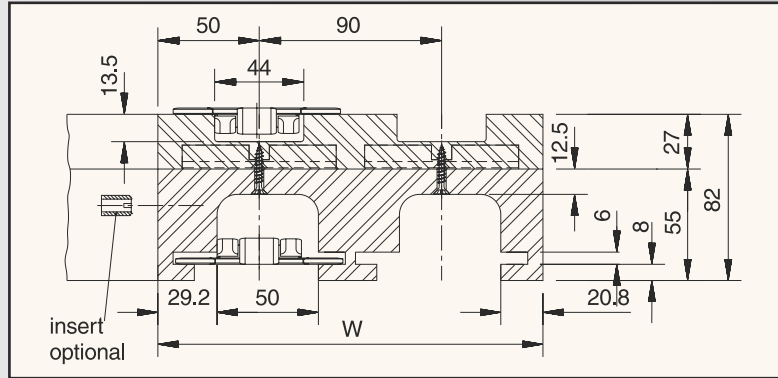

CURVE DIMENSIONS FOR MULTITRACK CURVES

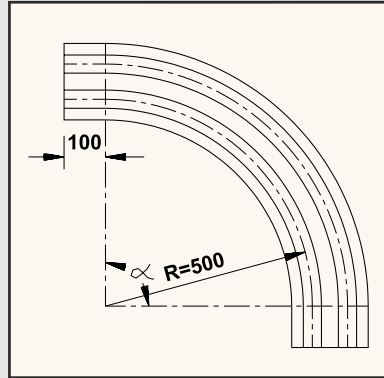

RADIUS

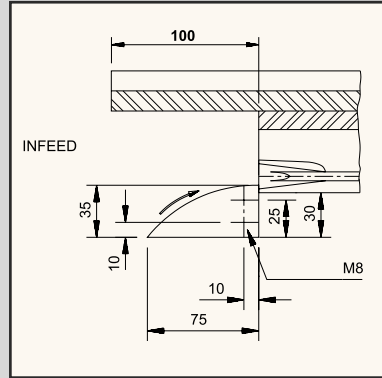

RETURN GUIDE SHOE

For (stainless) steel Magnetflex® chains, types:

- 10 M 31 M
- 45 M 31 M
- 60 M 31 (S)M
- 60 M 31 RM
- 60 M 84 SM

For plastic Magnetflex® chains, types:

- RHM 325 XL
- RHMD 325 XL
- RHM 325 AS
- RHM 325 XS
- RHM 84 XL

More than 6 tracks on request.

Magnetflex® curves can be supplied with M8 or M10 brass inserts to your detailed drawing.

A wide range of Magnetflex® curves with non-standard dimensions can be supplied.

Several Combi-G curves can be supplied for extremely abrasive applications.
 Several Combi-S curves can be supplied for high-speed applications.
 Several Combi-L curves can be supplied for noise reduction and high PV limits.
 Magnetflex® CIP-curves can be supplied for 'Cleaning In Place' (CIP) applications.

MAGNETFLEX® CURVES



**MAGNETFLEX®
COMBI-A
VERSION C3**

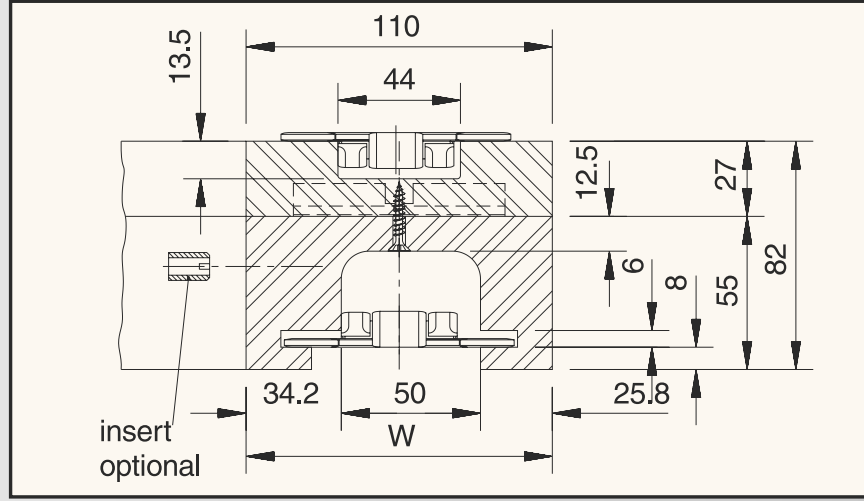

MATERIAL
page 159

page 17

page 6, 11

Angle	Code nr.	Width W
		mm
1 TRACK		
15°	704.07.16	110
30°	704.07.31	
45°	704.07.46	
60°	704.07.61	
75°	704.07.76	
90°	704.07.01	
2 TRACKS		
15°	704.07.17	200
30°	704.07.32	
45°	704.07.47	
60°	704.07.62	
75°	704.07.77	
90°	704.07.02	
3 TRACKS		
15°	704.07.18	290
30°	704.07.33	
45°	704.07.48	
60°	704.07.63	
75°	704.07.78	
90°	704.07.03	
4 TRACKS		
15°	704.07.19	380
30°	704.07.34	
45°	704.07.49	
60°	704.07.64	
75°	704.07.79	
90°	704.07.04	
5 TRACKS		
15°	704.07.20	470
30°	704.07.35	
45°	704.07.50	
60°	704.07.65	
75°	704.07.80	
90°	704.07.05	
6 TRACKS		
15°	704.07.21	560
30°	704.07.36	
45°	704.07.51	
60°	704.07.66	
75°	704.07.81	
90°	704.07.06	

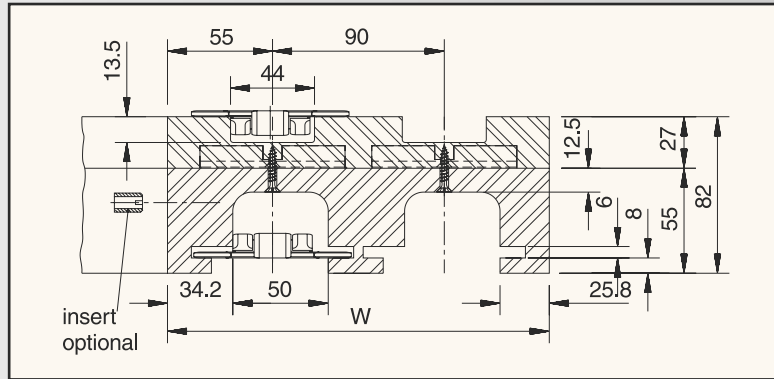

CURVE DIMENSIONS FOR MULTITRACK CURVES

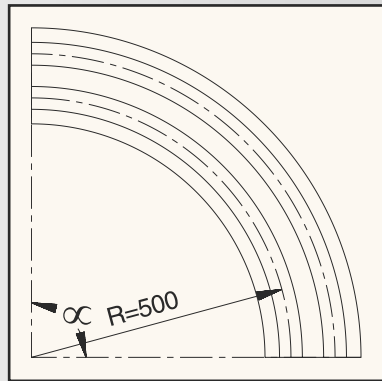

RADIUS

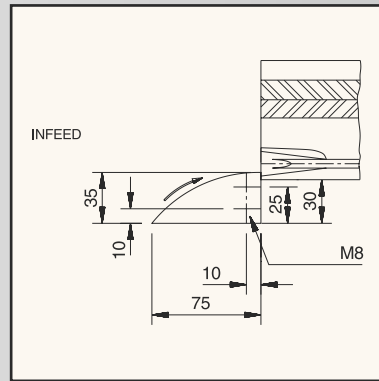

RETURN GUIDE SHOE

For (stainless) steel Magnetflex® chains, types:

- 10 M 31 M
- 45 M 31 M
- 60 M 31 (S)M
- 60 M 31 RM
- 60 M 84 SM

For plastic Magnetflex® chains, types:

- RHM 325 XL
- RHMD 325 XL
- RHM 325 AS
- RHM 325 XS
- RHM 84 XL

More than 6 tracks on request.

Magnetflex® curves can be supplied with M8 or M10 brass inserts to your detailed drawing.

A wide range of Magnetflex® curves with non-standard dimensions can be supplied.

Several Combi-G curves can be supplied for extremely abrasive applications.
 Several Combi-S curves can be supplied for high-speed applications.
 Several Combi-L curves can be supplied for noise reduction and high PV limits.
 Magnetflex® CIP-curves can be supplied for 'Cleaning In Place' (CIP) applications.

MAGNETFLEX® CURVES



**MAGNETFLEX®
COMBI-A
VERSION C4**

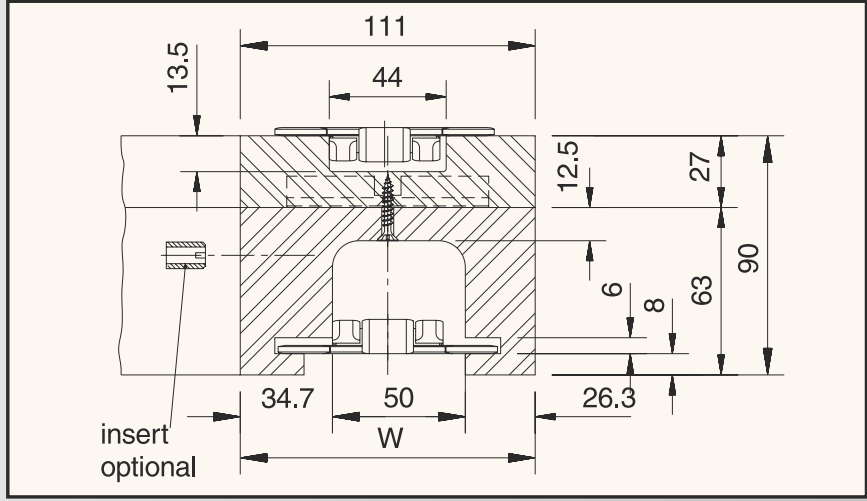

MATERIAL
page 159

page 17

page 6, 11

Angle	Code nr.	Width W
		mm
1 TRACK		
15°	704.08.16	111
30°	704.08.31	
45°	704.08.46	
60°	704.08.61	
75°	704.08.76	
90°	704.08.01	
2 TRACKS		
15°	704.08.17	196
30°	704.08.32	
45°	704.08.47	
60°	704.08.62	
75°	704.08.77	
90°	704.08.02	
3 TRACKS		
15°	704.08.18	281
30°	704.08.33	
45°	704.08.48	
60°	704.08.63	
75°	704.08.78	
90°	704.08.03	
4 TRACKS		
15°	704.08.19	366
30°	704.08.34	
45°	704.08.49	
60°	704.08.64	
75°	704.08.79	
90°	704.08.04	
5 TRACKS		
15°	704.08.20	451
30°	704.08.35	
45°	704.08.50	
60°	704.08.65	
75°	704.08.80	
90°	704.08.05	
6 TRACKS		
15°	704.08.21	536
30°	704.08.36	
45°	704.08.51	
60°	704.08.66	
75°	704.08.81	
90°	704.08.06	

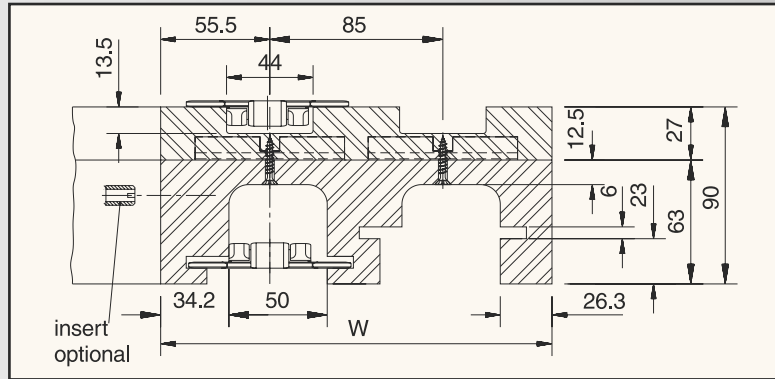

CURVE DIMENSIONS FOR MULTITRACK CURVES

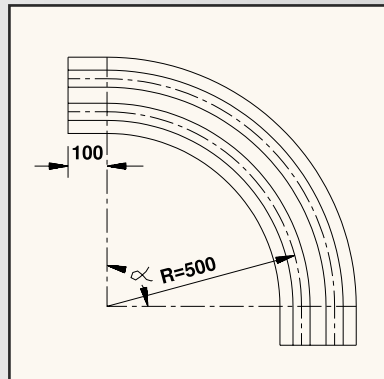

RADIUS

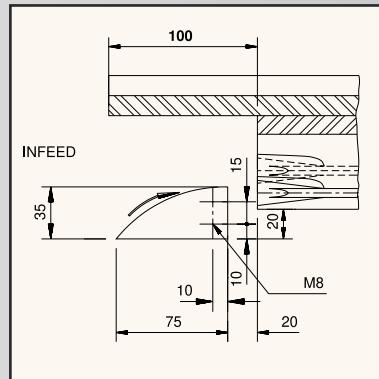

RETURN GUIDE SHOE

For (stainless) steel Magnetflex® chains, types:

- 10 M 31 M
- 45 M 31 M
- 60 M 31 (S)M
- 60 M 31 RM
- 60 M 84 SM

For plastic Magnetflex® chains, types:

- RHM 325 XL
- RHMD 325 XL
- RHM 325 AS
- RHM 325 XS
- RHM 84 XL

More than 6 tracks on request.

Magnetflex® curves can be supplied with M8 or M10 brass inserts to your detailed drawing.

A wide range of Magnetflex® curves with non-standard dimensions can be supplied.

Several Combi-G curves can be supplied for extremely abrasive applications.
Several Combi-S curves can be supplied for high-speed applications.
Several Combi-L curves can be supplied for noise reduction and high PV limits.
Magnetflex® CIP-curves can be supplied for 'Cleaning In Place' (CIP) applications.

MAGNETFLEX® CURVES

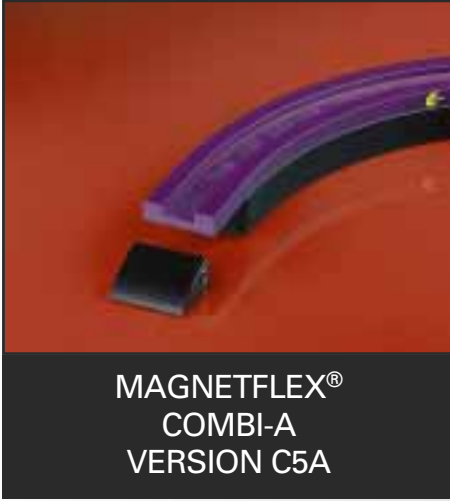

**MAGNETFLEX®
COMBI-A
VERSION C5A**

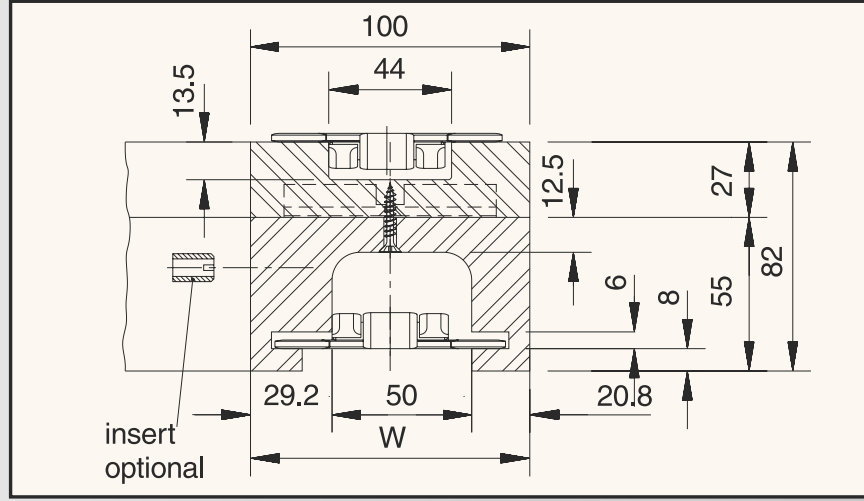

MATERIAL
page 159

page 17

page 6, 11

Angle	Code nr.	Width W mm
1 TRACK		
15°	704.09.16	100
30°	704.09.31	
45°	704.09.46	
60°	704.09.61	
75°	704.09.76	
90°	704.09.01	

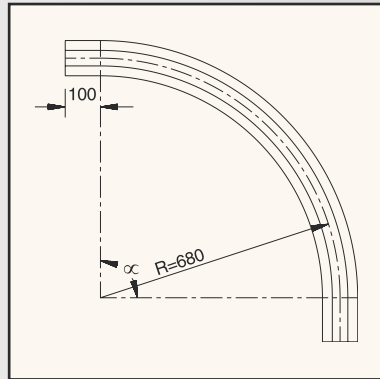

RADIUS

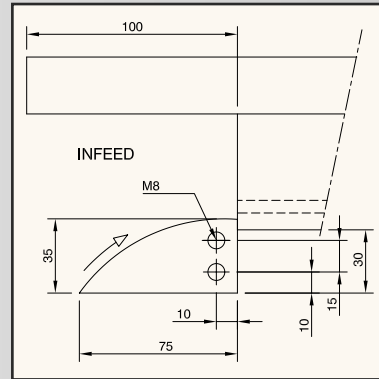

RETURN GUIDE SHOE

For (stainless) steel Magnetflex® chains, types:

- 10 M 31 M
- 45 M 31 M
- 60 M 31 (S)M
- 60 M 31 RM
- 60 M 84 SM

For plastic Magnetflex® chains, types:

- RHM 325 XL/AS/XS
- RHMD 325 XL
- RHM 84 XL

More than 1 track on request.



**MAGNETFLEX®
COMBI-A
VERSION C5B**

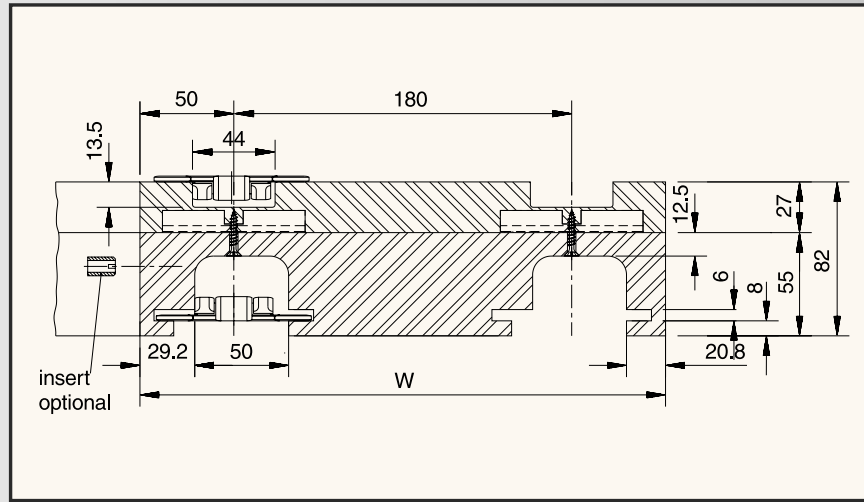

MATERIAL
page 159

page 17

page 6, 11

Angle	Code nr.	Width W mm
2 TRACKS		
15°	704.10.17	280
30°	704.10.32	
45°	704.10.47	
60°	704.10.62	
75°	704.10.77	
90°	704.10.02	

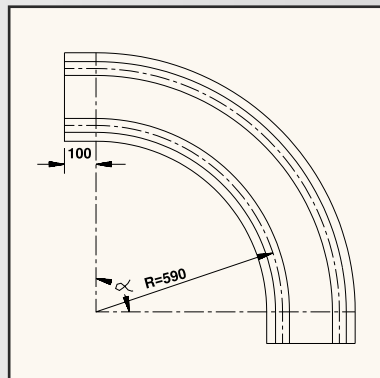

RADIUS

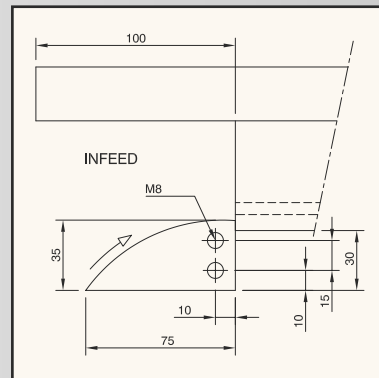

RETURN GUIDE SHOE

For (stainless) steel Magnetflex® chains, types:

- 10 M 31 M
- 45 M 31 M
- 60 M 31 (S)M
- 60 M 31 RM
- 60 M 84 SM

For plastic Magnetflex® chains, types:

- RHM 325 XL/AS/XS
- RHMD 325 XL
- RHM 84 XL

Special twin-track design for crate conveyors.

Magnetflex® curves can be supplied with M8 or M10 brass inserts to your detailed drawing.

A wide range of Magnetflex® curves with non-standard dimensions can be supplied.

Several Combi-G curves can be supplied for extremely abrasive applications. Several Combi-S curves can be supplied for high-speed applications. Several Combi-L curves can be supplied for noise reduction and high PV limits. CIP-curves can be supplied for 'Cleaning In Place' applications.

MAGNETFLEX® CURVES

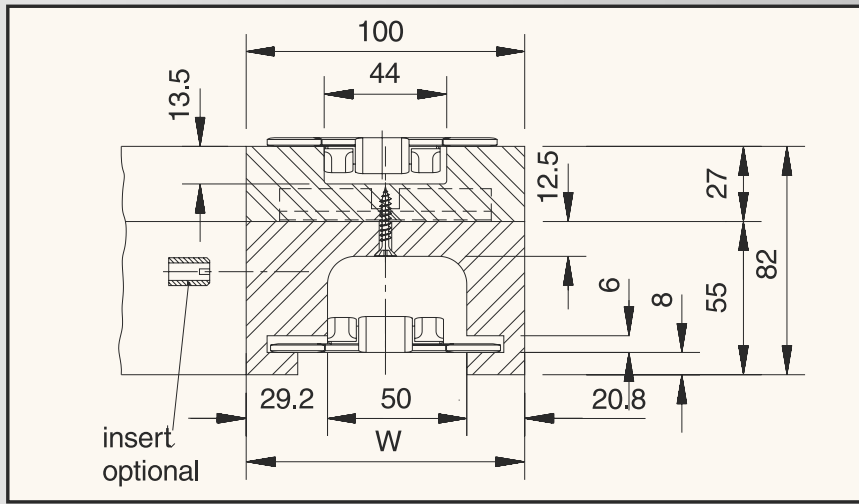

MATERIAL
page 159

page 17

page 6, 11

Angle	Code nr.	Width W mm
1 TRACK		
15°	704.11.16	100
30°	704.11.31	
45°	704.11.46	
60°	704.11.61	
75°	704.11.76	
90°	704.11.01	

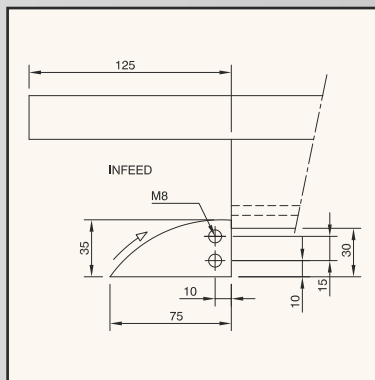
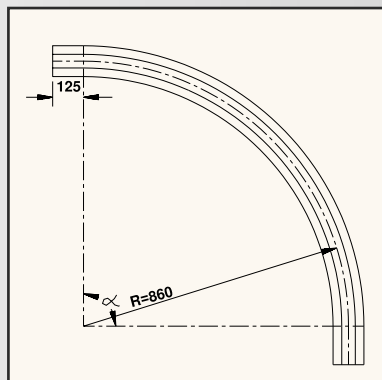

For (stainless) steel Magnetflex® chains, types:
 10 M 31 M
 45 M 31 M
 60 M 31 (S)M
 60 M 31 RM
 60 M 84 SM

For plastic Magnetflex® chains, types:
 RHM 325 XL/AS/XS
 RHMD 325 XL
 RHM 84 XL

More than 1 track on request.

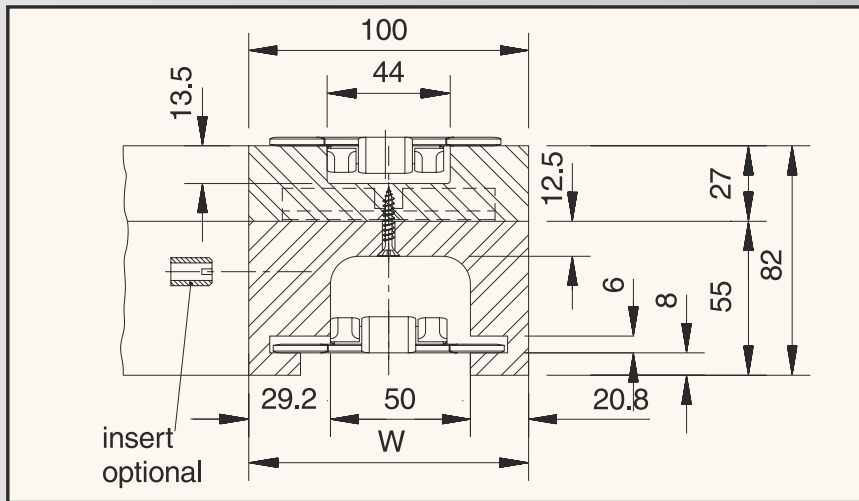

MATERIAL
page 159

page 17

page 6, 11

Angle	Code nr.	Width W mm
1 TRACK		
15°	704.12.16	100
30°	704.12.31	
45°	704.12.46	
60°	704.12.61	
75°	704.12.76	
90°	704.12.01	

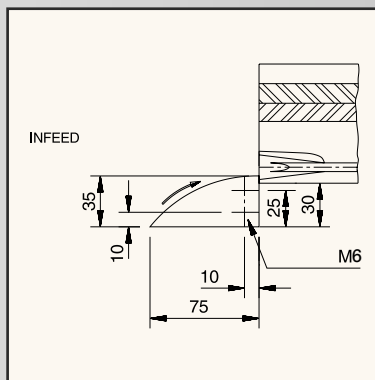
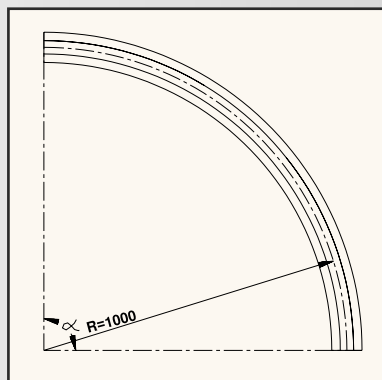

For (stainless) steel Magnetflex® chains, types:
 10 M 31 M
 45 M 31 M
 60 M 31 (S)M
 60 M 31 RM
 60 M 84 SM

For plastic Magnetflex® chains, types:
 RHM 325 XL/AS/XS
 RHMD 325 XL
 RHM 84 XL

More than 1 track on request.

Magnetflex® curves can be supplied with M8 or M10 brass inserts to your detailed drawing.

A wide range of Magnetflex® curves with non-standard dimensions can be supplied.

Several Combi-G curves can be supplied for extremely abrasive applications. Several Combi-S curves can be supplied for high-speed applications. Several Combi-L curves can be supplied for noise reduction and high PV limits. Magnetflex® CIP-curves can be supplied for 'Cleaning In Place' (CIP) applications.

MAGNETFLEX® CURVES

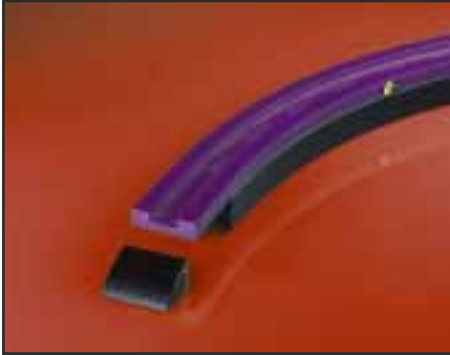

**MAGNETFLEX®
COMBI-A
VERSION C6**

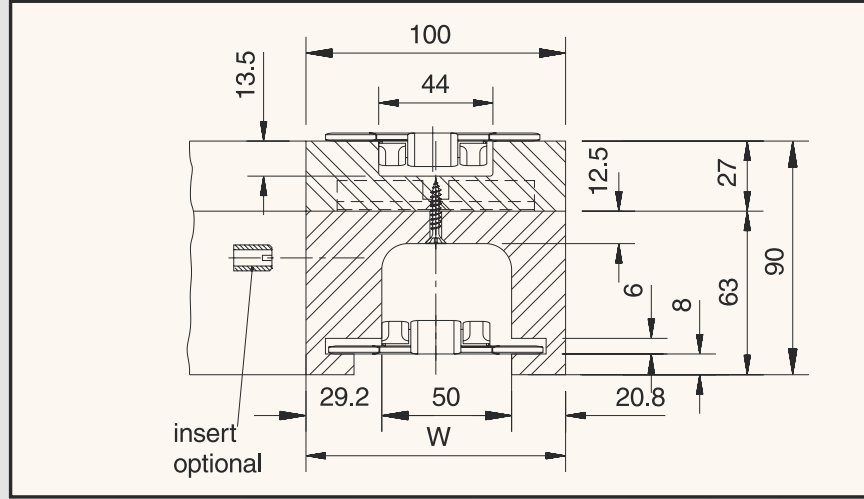

MATERIAL
page 159

page 17

page 6, 11

Angle	Code nr.	Width W
		mm
1 TRACK		
15°	704.14.16	100
30°	704.14.31	
45°	704.14.46	
60°	704.14.61	
75°	704.14.76	
90°	704.14.01	
2 TRACKS		
15°	704.14.17	185
30°	704.14.32	
45°	704.14.47	
60°	704.14.62	
75°	704.14.77	
90°	704.14.02	
3 TRACKS		
15°	704.14.18	270
30°	704.14.33	
45°	704.14.48	
60°	704.14.63	
75°	704.14.78	
90°	704.14.03	
4 TRACKS		
15°	704.14.19	355
30°	704.14.34	
45°	704.14.49	
60°	704.14.64	
75°	704.14.79	
90°	704.14.04	
5 TRACKS		
15°	704.14.20	440
30°	704.14.35	
45°	704.14.50	
60°	704.14.65	
75°	704.14.80	
90°	704.14.05	
6 TRACKS		
15°	704.14.21	525
30°	704.14.36	
45°	704.14.51	
60°	704.14.66	
75°	704.14.81	
90°	704.14.06	

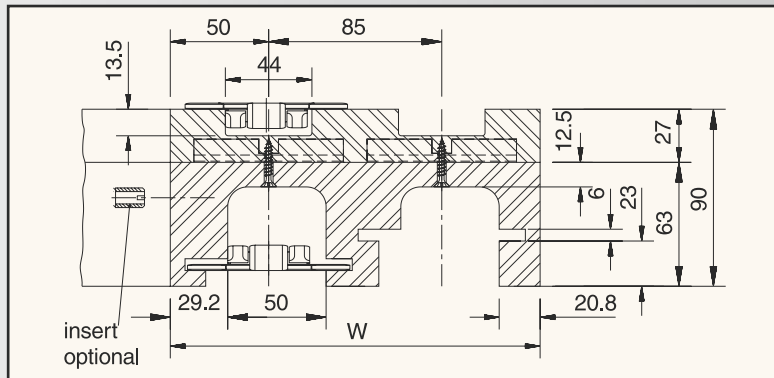

CURVE DIMENSIONS FOR MULTITRACK CURVES

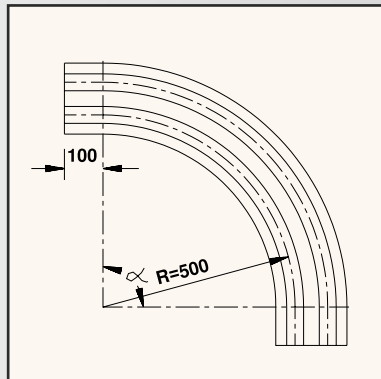

RADIUS

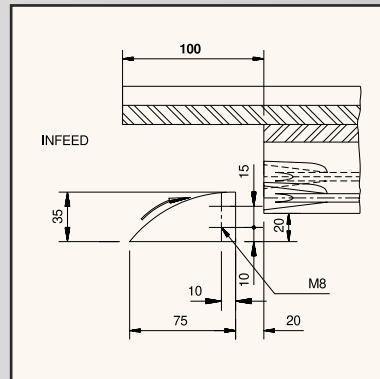

RETURN GUIDE SHOE

For (stainless) steel Magnetflex® chains, types:

- 10 M 31 M
- 45 M 31 M
- 60 M 31 (S)M
- 60 M 31 RM
- 60 M 84 SM

For plastic Magnetflex® chains, types:

- RHM 325 XL
- RHMD 325 XL
- RHM 325 AS
- RHM 325 XS
- RHM 84 XL

More than 6 tracks on request.

Magnetflex® curves can be supplied with M8 or M10 brass inserts to your detailed drawing.

A wide range of Magnetflex® curves with non-standard dimensions can be supplied.

Several Combi-G curves can be supplied for extremely abrasive applications.
Several Combi-S curves can be supplied for high-speed applications.
Several Combi-L curves can be supplied for noise reduction and high PV limits.
Magnetflex® CIP-curves can be supplied for 'Cleaning In Place' (CIP) applications.

MAGNETFLEX® CURVES



**MAGNETFLEX®
COMBI-A
VERSION C7**

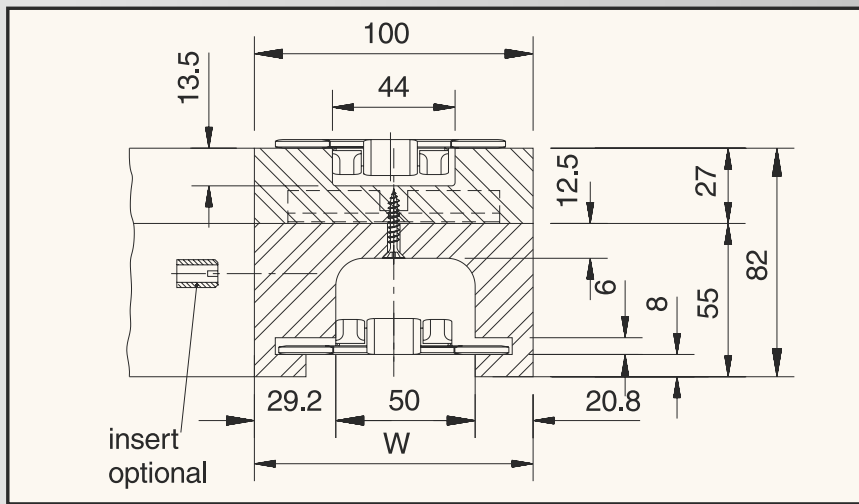

MATERIAL

page 159



page 17



page 6, 11

Angle	Code nr.	Width W
		mm
1 TRACK		
15°	704.15.16	100
30°	704.15.31	
45°	704.15.46	
60°	704.15.61	
75°	704.15.76	
90°	704.15.01	
2 TRACKS		
15°	704.15.17	185
30°	704.15.32	
45°	704.15.47	
60°	704.15.62	
75°	704.15.77	
90°	704.15.02	
3 TRACKS		
15°	704.15.18	270
30°	704.15.33	
45°	704.15.48	
60°	704.15.63	
75°	704.15.78	
90°	704.15.03	
4 TRACKS		
15°	704.15.19	355
30°	704.15.34	
45°	704.15.49	
60°	704.15.64	
75°	704.15.79	
90°	704.15.04	
5 TRACKS		
15°	704.15.20	440
30°	704.15.35	
45°	704.15.50	
60°	704.15.65	
75°	704.15.80	
90°	704.15.05	
6 TRACKS		
15°	704.15.21	525
30°	704.15.36	
45°	704.15.51	
60°	704.15.66	
75°	704.15.81	
90°	704.15.06	

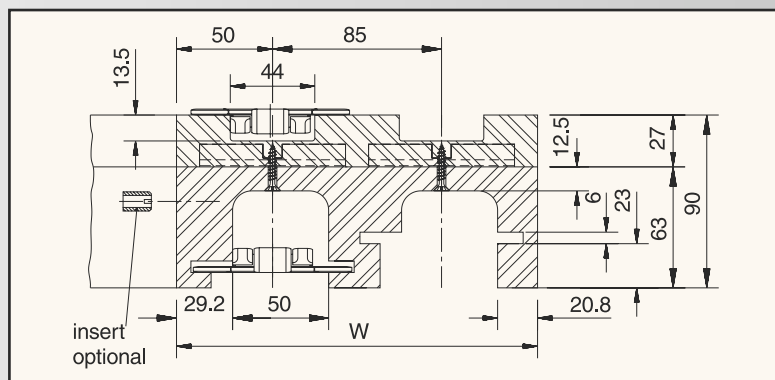

CURVE DIMENSIONS FOR MULTITRACK CURVES

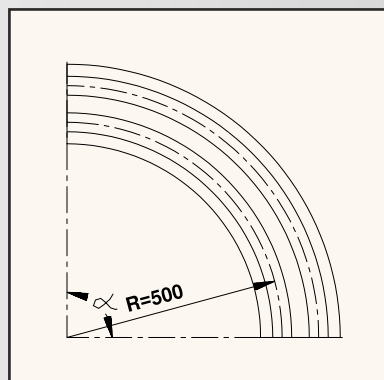

RADIUS

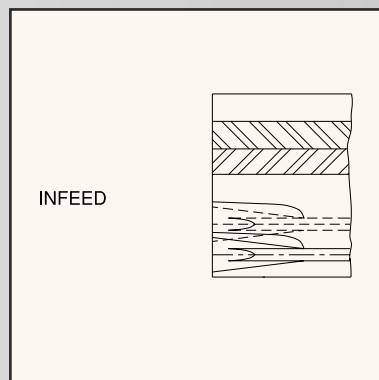

RETURN GUIDE SHOE NOT INCLUDED

For (stainless) steel
Magnetflex® chains,
types:

- 10 M 31 M
- 45 M 31 M
- 60 M 31 (S)M
- 60 M 31 RM
- 60 M 84 SM

For plastic
Magnetflex® chains,
types:

- RHM 325 XL
- RHMD 325 XL
- RHM 325 AS
- RHM 325 XS
- RHM 84 XL

More than 6 tracks on request.

Magnetflex® curves can be supplied with M8 or M10 brass inserts to your detailed drawing.

A wide range of Magnetflex® curves with non-standard dimensions can be supplied.

Several Combi-G curves can be supplied for extremely abrasive applications.
Several Combi-S curves can be supplied for high-speed applications.
Several Combi-L curves can be supplied for noise reduction and high PV limits.
Magnetflex® CIP-curves can be supplied for 'Cleaning In Place' (CIP) applications.

MAGNETFLEX® CURVES

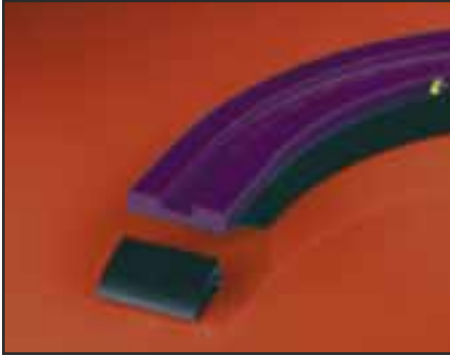

**MAGNETFLEX®
COMBI-A
VERSION C21A**

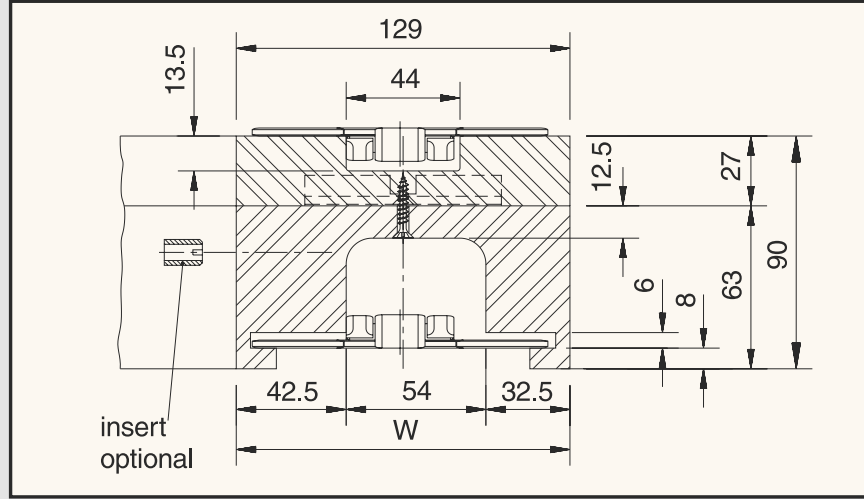

MATERIAL
page 159

page 17

page 6

Angle	Code nr.	Width W
		mm
1 TRACK		
15°	714.08.16	129
30°	714.08.31	
45°	714.08.46	
60°	714.08.61	
75°	714.08.76	
90°	714.08.01	
2 TRACKS		
15°	714.08.17	249
30°	714.08.32	
45°	714.08.47	
60°	714.08.62	
75°	714.08.77	
90°	714.08.02	
3 TRACKS		
15°	714.08.18	369
30°	714.08.33	
45°	714.08.48	
60°	714.08.63	
75°	714.08.78	
90°	714.08.03	
4 TRACKS		
15°	714.08.19	489
30°	714.08.34	
45°	714.08.49	
60°	714.08.64	
75°	714.08.79	
90°	714.08.04	

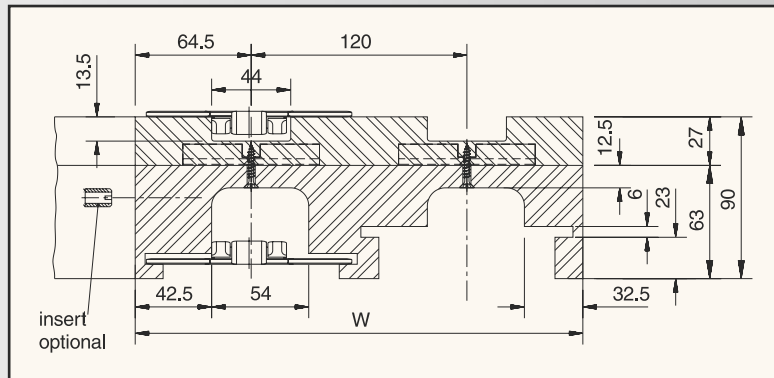

CURVE DIMENSIONS FOR MULTI TRACK CURVES

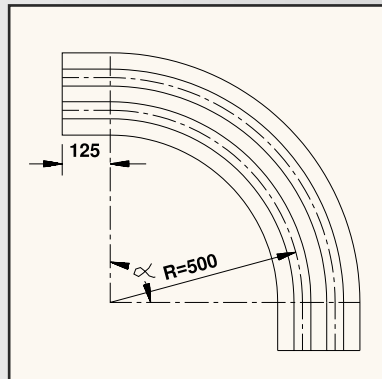

RADIUS

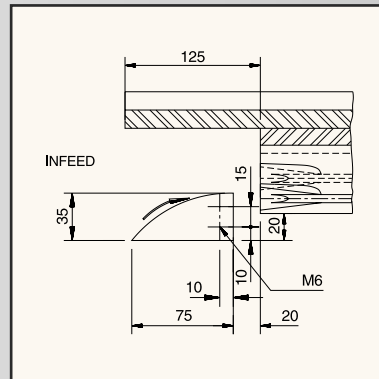

RETURN GUIDE SHOE

For (stainless) steel Magnetflex® chains, types:

- 10 M 42 M
- 45 M 42 M
- 60 M 42 M

For plastic Magnetflex® chains, types:

- RHM 450 XL
- RHMD 450 XL

More than 4 tracks on request.

Magnetflex® curves can be supplied with M8 or M10 brass inserts to your detailed drawing.

A wide range of Magnetflex® curves with non-standard dimensions can be supplied.

Several Combi-G curves can be supplied for extremely abrasive applications. Several Combi-S curves can be supplied for high-speed applications. Several Combi-L curves can be supplied for noise reduction and high PV limits. CIP-curves can be supplied for 'Cleaning In Place' applications.

MAGNETFLEX® CURVES



**MAGNETFLEX®
COMBI-A
VERSION C22A**

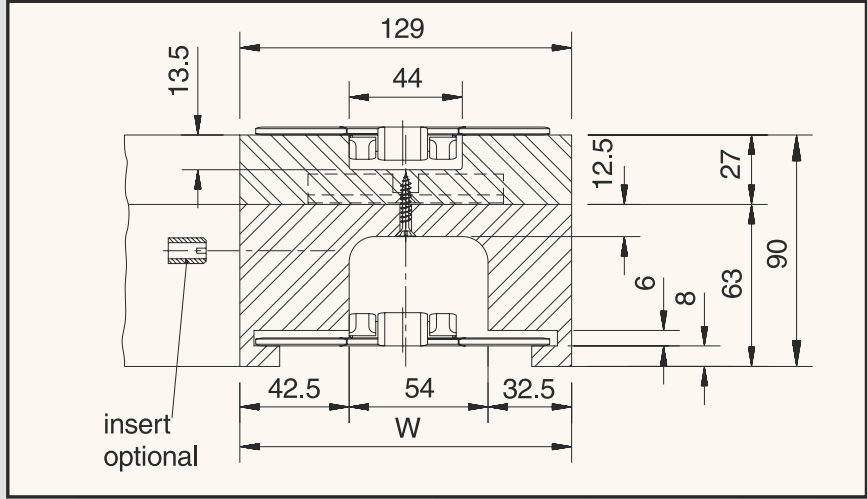

MATERIAL
page 159

page 17

page 6

Angle	Code nr.	Width W
		mm
1 TRACK		
15°	714.09.16	129
30°	714.09.31	
45°	714.09.46	
60°	714.09.61	
75°	714.09.76	
90°	714.09.01	
2 TRACKS		
15°	714.09.17	249
30°	714.09.32	
45°	714.09.47	
60°	714.09.62	
75°	714.09.77	
90°	714.09.02	
3 TRACKS		
15°	714.09.18	369
30°	714.09.33	
45°	714.09.48	
60°	714.09.63	
75°	714.09.78	
90°	714.09.03	
4 TRACKS		
15°	714.09.19	489
30°	714.09.34	
45°	714.09.49	
60°	714.09.64	
75°	714.09.79	
90°	714.09.04	

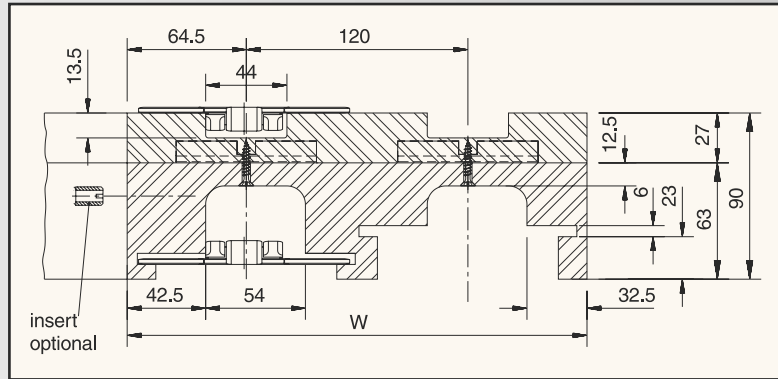

CURVE DIMENSIONS FOR MULTITRACK CURVES

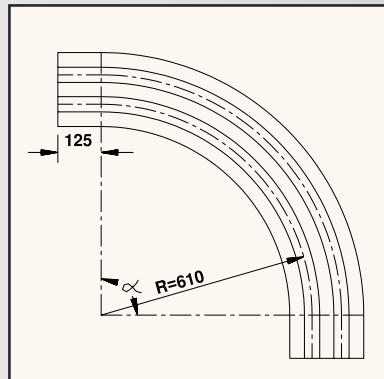

RADIUS

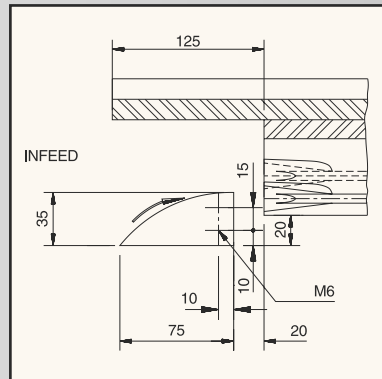

RETURN GUIDE SHOE

For (stainless) steel Magnetflex® chains, types:

- 10 M 42 M
- 45 M 42 M
- 60 M 42 M

For plastic Magnetflex® chains, types:

- RHM 450 XL
- RHMD 450 XL

More than 4 tracks on request.

Magnetflex® curves can be supplied with M8 or M10 brass inserts to your detailed drawing.

A wide range of Magnetflex® curves with non-standard dimensions can be supplied.

Several Combi-G curves can be supplied for extremely abrasive applications. Several Combi-S curves can be supplied for high-speed applications. Several Combi-L curves can be supplied for noise reduction and high PV limits. CIP-curves can be supplied for 'Cleaning In Place' applications.

MAGNETFLEX® CURVES



**MAGNETFLEX®
COMBI-A
VERSION C27**

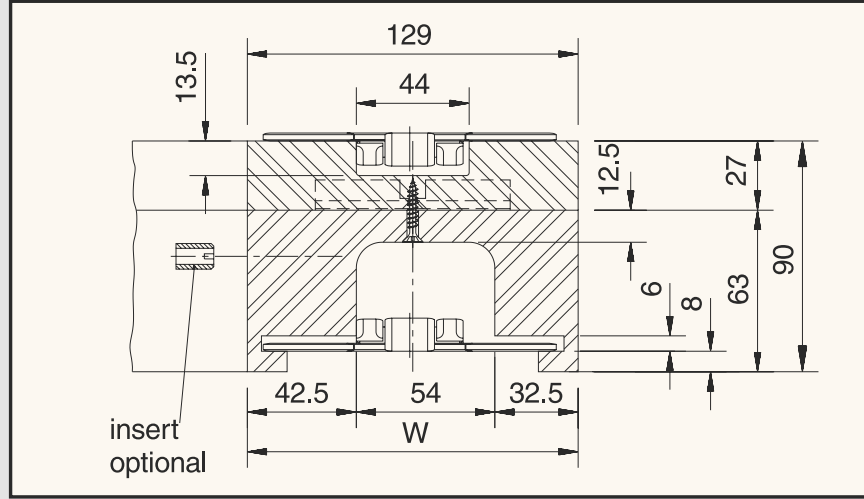

MATERIAL
page 159

page 17

page 6

Angle	Code nr.	Width W
		mm
1 TRACK		
15°	714.21.16	129
30°	714.21.31	
45°	714.21.46	
60°	714.21.61	
75°	714.21.76	
90°	714.21.01	
2 TRACKS		
15°	714.21.17	246
30°	714.21.32	
45°	714.21.47	
60°	714.21.62	
75°	714.21.77	
90°	714.21.02	
3 TRACKS		
15°	714.21.18	363
30°	714.21.33	
45°	714.21.48	
60°	714.21.63	
75°	714.21.78	
90°	714.21.03	
4 TRACKS		
15°	714.21.19	480
30°	714.21.34	
45°	714.21.49	
60°	714.21.64	
75°	714.21.79	
90°	714.21.04	

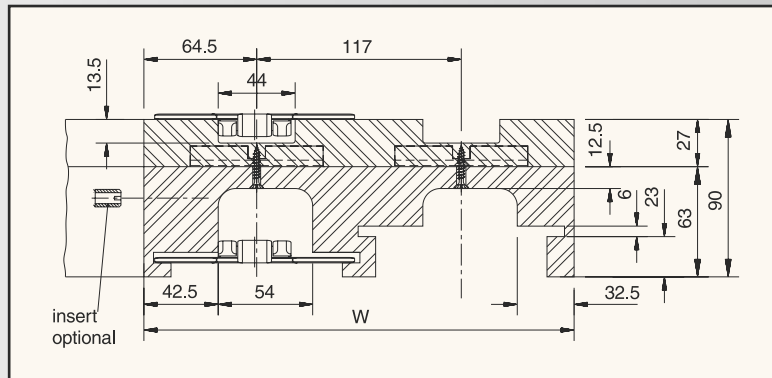

CURVE DIMENSIONS FOR MULTITRACK CURVES

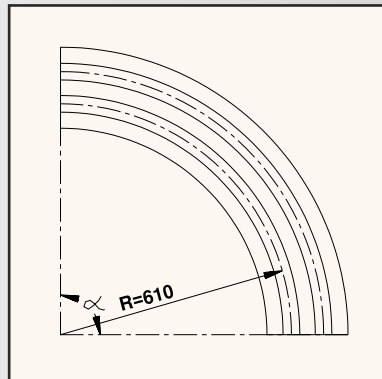

RADIUS

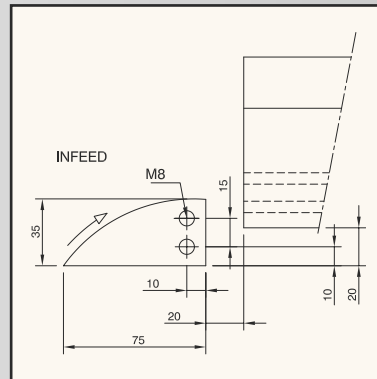

RETURN GUIDE SHOE

For (stainless) steel Magnetflex® chains, types:

- 10 M 42 M
- 45 M 42 M
- 60 M 42 M

For plastic Magnetflex® chains, types:

- RHM 450 XL
- RHMD 450 XL

More than 4 tracks on request.

Magnetflex® curves can be supplied with M8 or M10 brass inserts to your detailed drawing.

A wide range of Magnetflex® curves with non-standard dimensions can be supplied.

Several Combi-G curves can be supplied for extremely abrasive applications. Several Combi-S curves can be supplied for high-speed applications. Several Combi-L curves can be supplied for noise reduction and high PV limits. CIP-curves can be supplied for 'Cleaning In Place' applications.

MAGNETFLEX® CURVES

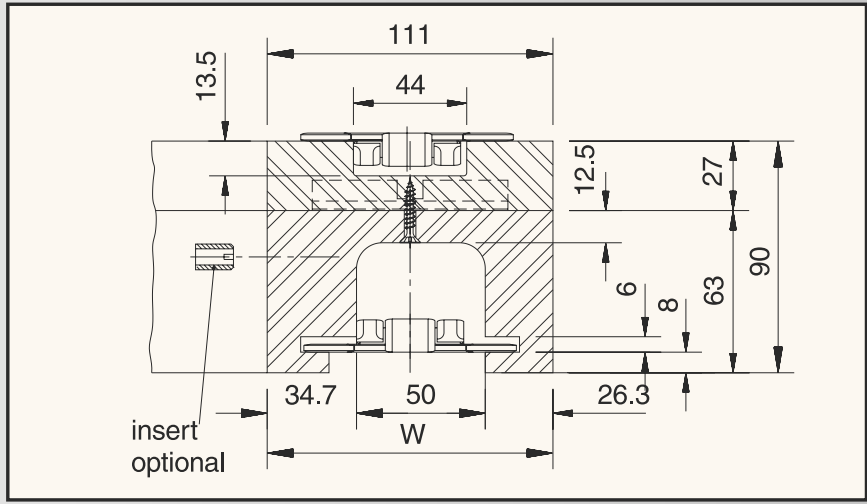

MATERIAL
page 159

page 17

page 6, 11

Angle	Code nr.	Width W
		mm
1 TRACK		
15°	704.28.16	111
30°	704.28.31	
45°	704.28.46	
60°	704.28.61	
75°	704.28.76	
90°	704.28.01	
2 TRACKS		
15°	704.28.17	196
30°	704.28.32	
45°	704.28.47	
60°	704.28.62	
75°	704.28.77	
90°	704.28.02	
3 TRACKS		
15°	704.28.18	281
30°	704.28.33	
45°	704.28.48	
60°	704.28.63	
75°	704.28.78	
90°	704.28.03	
4 TRACKS		
15°	704.28.19	366
30°	704.28.34	
45°	704.28.49	
60°	704.28.64	
75°	704.28.79	
90°	704.28.04	
5 TRACKS		
15°	704.28.20	451
30°	704.28.35	
45°	704.28.50	
60°	704.28.65	
75°	704.28.80	
90°	704.28.05	
6 TRACKS		
15°	704.28.21	536
30°	704.28.36	
45°	704.28.51	
60°	704.28.66	
75°	704.28.81	
90°	704.28.06	

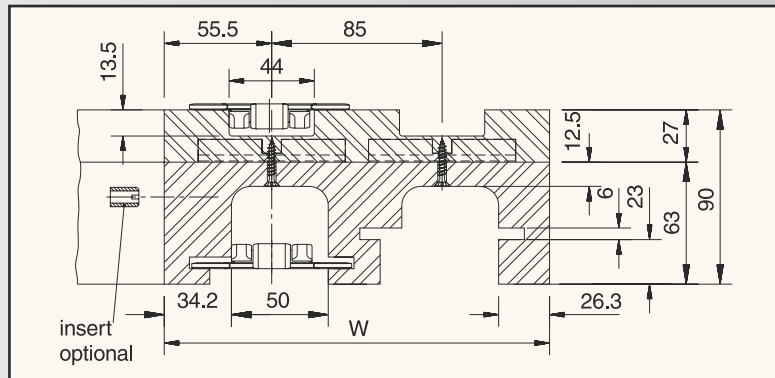

CURVE DIMENSIONS FOR MULTITRACK CURVES

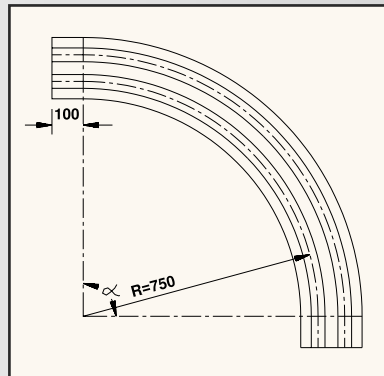

RADIUS

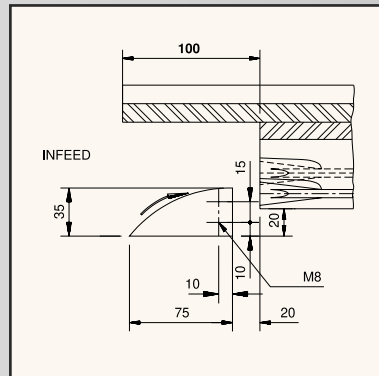

RETURN GUIDE SHOE

For (stainless) steel Magnetflex® chains, types:

- 10 M 31 M
- 45 M 31 M
- 60 M 31 (S)M
- 60 M 31 RM
- 60 M 84 SM

For plastic Magnetflex® chains, types:

- RHM 325 XL
- RHMD 325 XL
- RHM 325 AS
- RHM 325 XS
- RHM 84 XL

More than 6 tracks on request.

Magnetflex® curves can be supplied with M8 or M10 brass inserts to your detailed drawing.

A wide range of Magnetflex® curves with non-standard dimensions can be supplied.

Several Combi-G curves can be supplied for extremely abrasive applications.
 Several Combi-S curves can be supplied for high-speed applications.
 Several Combi-L curves can be supplied for noise reduction and high PV limits.
 Magnetflex® CIP-curves can be supplied for 'Cleaning In Place' (CIP) applications.

MAGNETFLEX® CURVES

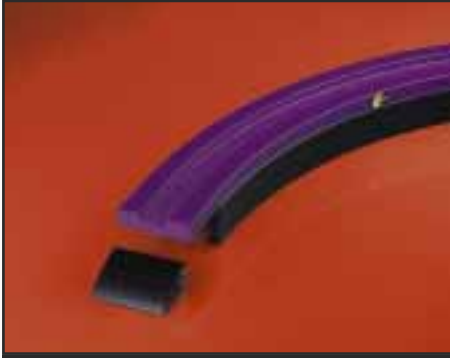

**MAGNETFLEX®
COMBI-A
VERSION C43**

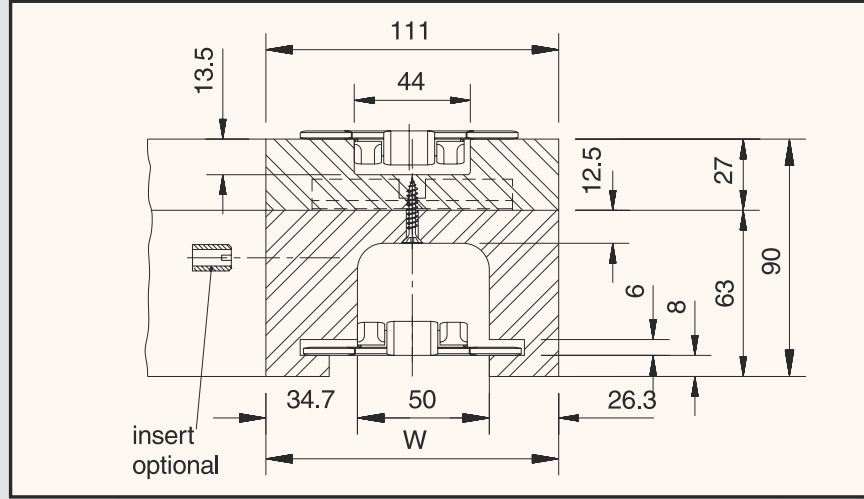

MATERIAL
page 159

page 17

page 6, 11

Angle	Code nr.	Width W
		mm
1 TRACK		
15°	704.29.16	111
30°	704.29.31	
45°	704.29.46	
60°	704.29.61	
75°	704.29.76	
90°	704.29.01	
2 TRACKS		
15°	704.29.17	196
30°	704.29.32	
45°	704.29.47	
60°	704.29.62	
75°	704.29.77	
90°	704.29.02	
3 TRACKS		
15°	704.29.18	281
30°	704.29.33	
45°	704.29.48	
60°	704.29.63	
75°	704.29.78	
90°	704.29.03	
4 TRACKS		
15°	704.29.19	366
30°	704.29.34	
45°	704.29.49	
60°	704.29.64	
75°	704.29.79	
90°	704.29.04	
5 TRACKS		
15°	704.29.20	451
30°	704.29.35	
45°	704.29.50	
60°	704.29.65	
75°	704.29.80	
90°	704.29.05	
6 TRACKS		
15°	704.29.21	536
30°	704.29.36	
45°	704.29.51	
60°	704.29.66	
75°	704.29.81	
90°	704.29.06	

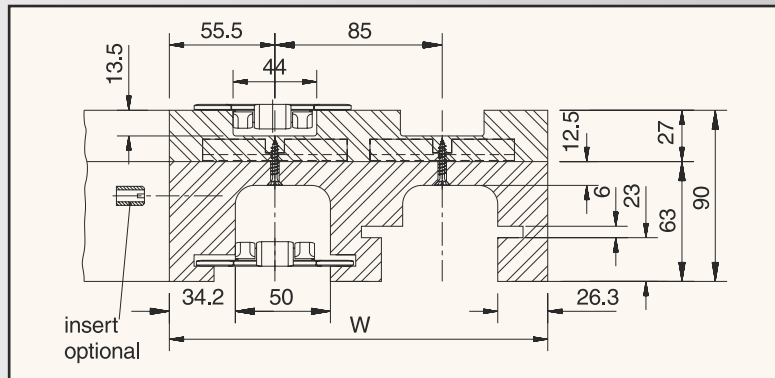

CURVE DIMENSIONS FOR MULTITRACK CURVES

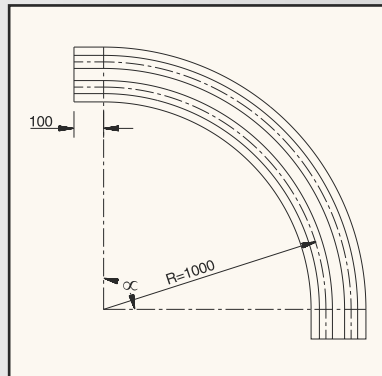

RADIUS

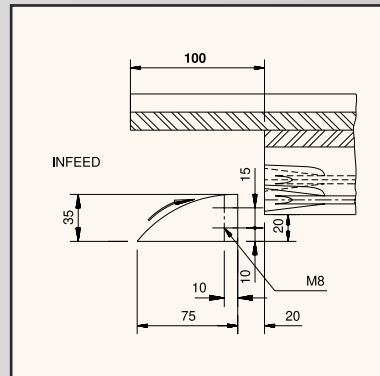

RETURN GUIDE SHOE

For (stainless) steel Magnetflex® chains, types:

- 10 M 31 M
- 45 M 31 M
- 60 M 31 (S)M
- 60 M 31 RM
- 60 M 84 SM

For plastic Magnetflex® chains, types:

- RHM 325 XL
- RHMD 325 XL
- RHM 325 AS
- RHM 325 XS
- RHM 84 XL

More than 6 tracks on request.

Magnetflex® curves can be supplied with M8 or M10 brass inserts to your detailed drawing.

A wide range of Magnetflex® curves with non-standard dimensions can be supplied.

Several Combi-G curves can be supplied for extremely abrasive applications.

Several Combi-S curves can be supplied for high-speed applications.

Several Combi-L curves can be supplied for noise reduction and high PV limits.

Magnetflex® CIP-curves can be supplied for 'Cleaning In Place' (CIP) applications.

MAGNETFLEX® CURVES



**MAGNETFLEX®
COMBI-A
VERSION C61**

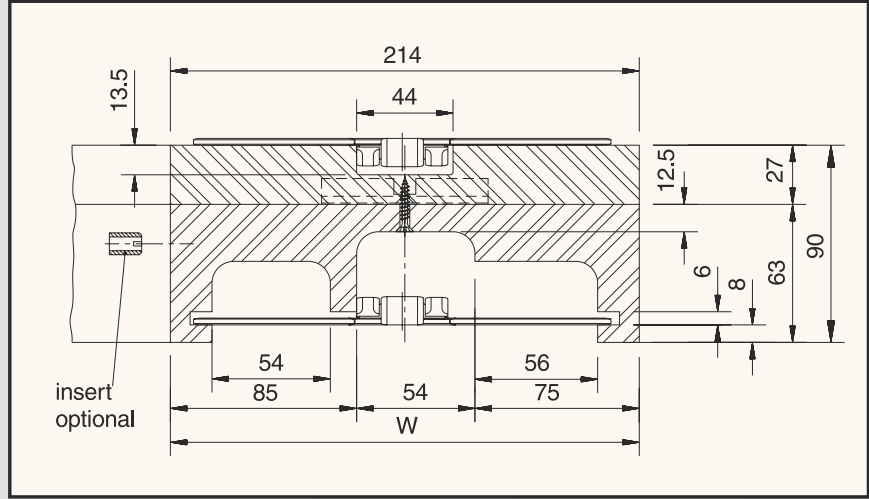

MATERIAL

page 159



page 6, 11

Angle	Code nr.	Width W
		mm
1 TRACK		
15°	724.05.16	214
30°	724.05.31	
45°	724.05.46	
60°	724.05.61	
75°	724.05.76	
90°	724.05.01	
2 TRACKS		
15°	724.05.17	410
30°	724.05.32	
45°	724.05.47	
60°	724.05.62	
75°	724.05.77	
90°	724.05.02	
3 TRACKS		
15°	724.05.18	606
30°	724.05.33	
45°	724.05.48	
60°	724.05.63	
75°	724.05.78	
90°	724.05.03	
4 TRACKS		
15°	724.05.19	802
30°	724.05.34	
45°	724.05.49	
60°	724.05.64	
75°	724.05.79	
90°	724.05.04	

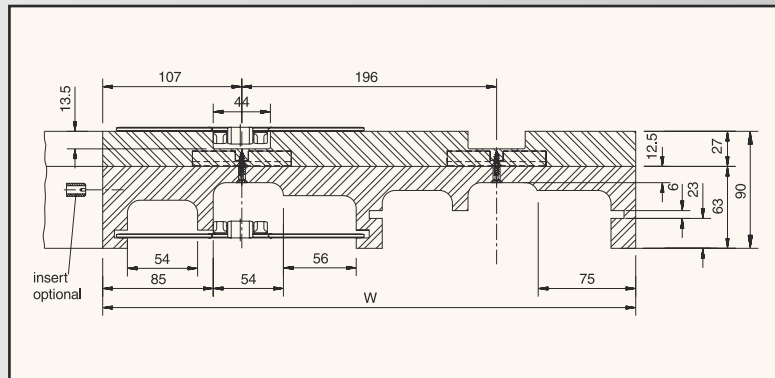

CURVE DIMENSIONS FOR MULTITRACK CURVES

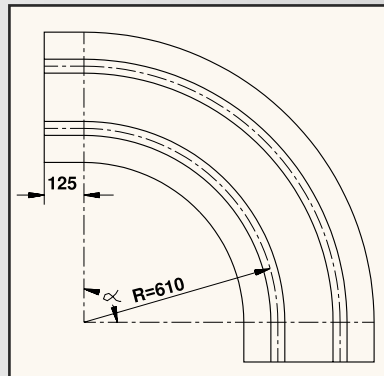

RADIUS

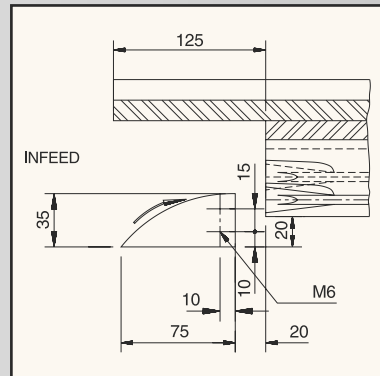

RETURN GUIDE SHOE

For (stainless) steel Magnetflex® chains, types:

10 M 72 M
60 M 72 M
60 M 72 RM

More than 4 tracks on request.

Magnetflex® curves can be supplied with M8 or M10 brass inserts to your detailed drawing.

A wide range of Magnetflex® curves with non-standard dimensions can be supplied.

Several Combi-G curves can be supplied for extremely abrasive applications. Magnetflex® CIP-curves can be supplied for 'Cleaning In Place' (CIP) applications.

MAGNETFLEX® CURVES



**MAGNETFLEX®
COMBI-A
VERSION C65**

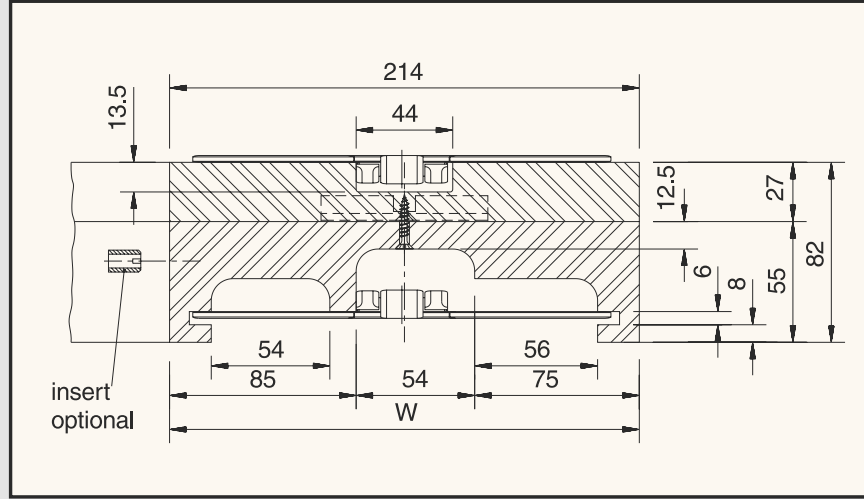

MATERIAL

page 159



page 6, 11

Angle	Code nr.	Width W mm
1 TRACK		
15°	724.07.16	214
30°	724.07.31	
45°	724.07.46	
60°	724.07.61	
75°	724.07.76	
90°	724.07.01	

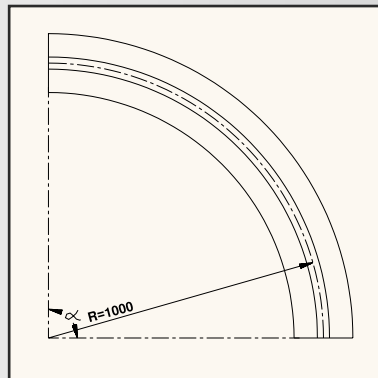

RADIUS

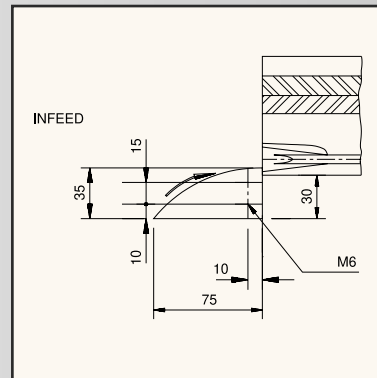

RETURN GUIDE SHOE

For (stainless) steel Magnetflex® chains, types:

10 M 72 M
60 M 72 M
60 M 72 RM

More than 1 track on request.



**MAGNETFLEX®
COMBI-A
VERSION C66**

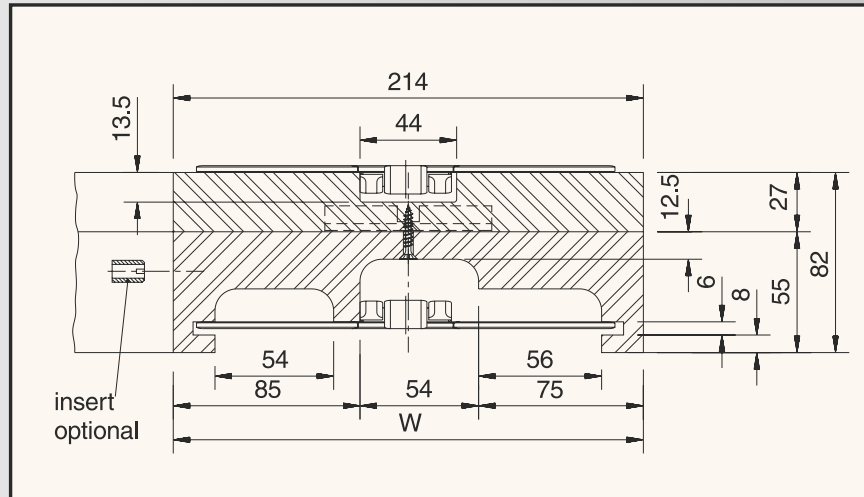

MATERIAL

page 159



page 6, 11

Angle	Code nr.	Width W mm
1 TRACK		
15°	724.11.16	214
30°	724.11.31	
45°	724.11.46	
60°	724.11.61	
75°	724.11.76	
90°	724.11.01	

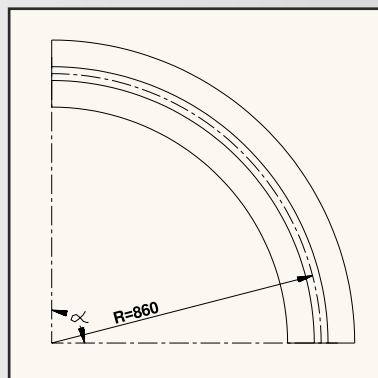

RADIUS

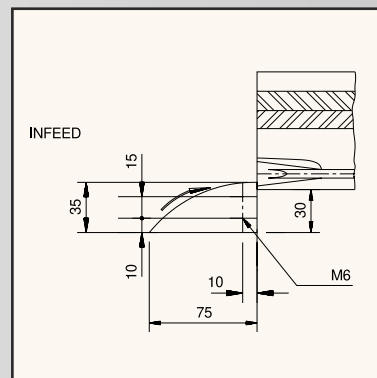

RETURN GUIDE SHOE

For (stainless) steel Magnetflex® chains, types:

10 M 72 M
60 M 72 M
60 M 72 RM

More than 1 track on request.

Magnetflex® curves can be supplied with M8 or M10 brass inserts to your detailed drawing.

A wide range of Magnetflex® curves with non-standard dimensions can be supplied.

Several Combi-G curves can be supplied for extremely abrasive applications. CIP-curves are for 'Cleaning In Place' (CIP) applications.

MAGNETFLEX® CURVES



**MAGNETFLEX®
COMBI-A
VERSION C81**

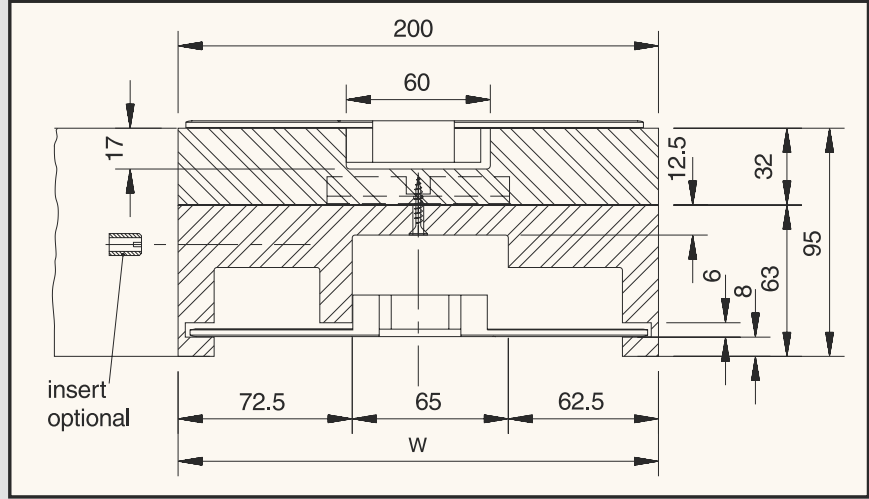

MATERIAL

page 159



page 18, 29



page 6, 11

Angle	Code nr.	Width W
		mm
1 TRACK		
15°	724.31.16	200
30°	724.31.31	
45°	724.31.46	
60°	724.31.61	
75°	724.31.76	
90°	724.31.01	
2 TRACKS		
15°	724.31.17	395
30°	724.31.32	
45°	724.31.47	
60°	724.31.62	
75°	724.31.77	
90°	724.31.02	
3 TRACKS		
15°	724.31.18	590
30°	724.31.33	
45°	724.31.48	
60°	724.31.63	
75°	724.31.78	
90°	724.31.03	
4 TRACKS		
15°	724.31.19	785
30°	724.31.34	
45°	724.31.49	
60°	724.31.64	
75°	724.31.79	
90°	724.31.04	

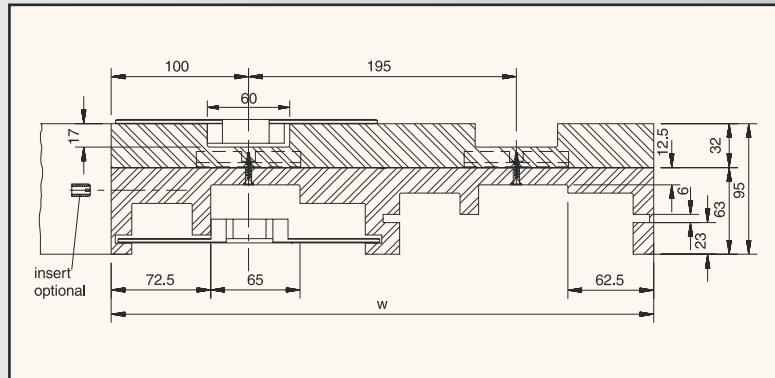

CURVE DIMENSIONS FOR MULTITRACK CURVES

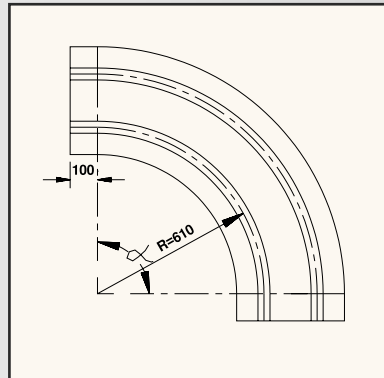

RADIUS

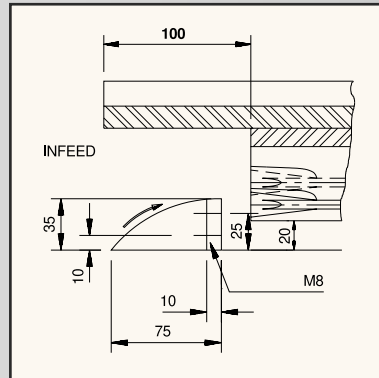

RETURN GUIDE SHOE

For plastic Magnetflex® chains, types:

HDFM 750 XL
HDFM 750 SG

For (stainless) steel Magnetflex® chains, types:

60 M 75 M
60 M 75 RM

More than 4 tracks on request.

Magnetflex® curves can be supplied with M8 or M10 brass inserts to your detailed drawing.

A wide range of Magnetflex® curves with non-standard dimensions can be supplied.

Several Combi-G curves can be supplied for extremely abrasive applications. Several Combi-S curves can be supplied for high-speed applications. Several Combi-L curves can be supplied for noise reduction and high PV limits. CIP-curves can be supplied for 'Cleaning In Place' applications.

MAGNETFLEX® CURVES



**MAGNETFLEX®
COMBI-A
VERSION C86**

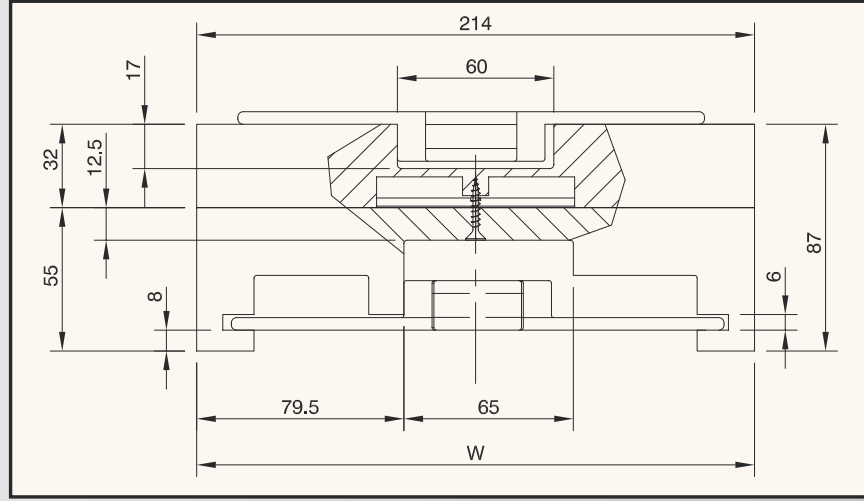

MATERIAL
page 159

page 18, 29

page 6, 11

Angle	Code nr.	Width W
		mm
1 TRACK		
15°	724.36.16	214
30°	724.36.31	
45°	724.36.46	
60°	724.36.61	
75°	724.36.76	
90°	724.36.01	

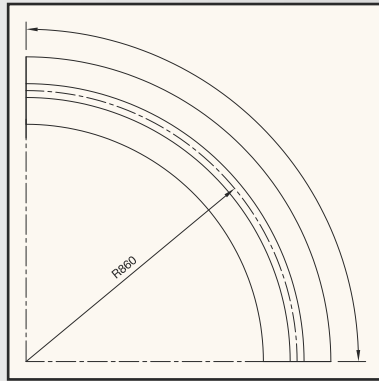

RADIUS

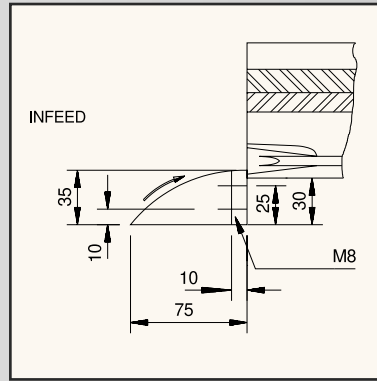

RETURN GUIDE SHOE

For (stainless) steel Magnetflex® chains, types:
60 M 75 M
60 M 75 RM

For plastic Magnetflex® chains, types:
HDFM 750 XL
HDFM 750 SG

More than 1 track on request.

Magnetflex® curves can be supplied with M8 or M10 brass inserts to your detailed drawing.

A wide range of Magnetflex® curves with non-standard dimensions can be supplied.

- Several Combi-G curves can be supplied for extremely abrasive applications.
- Several Combi-S curves can be supplied for high-speed applications.
- Several Combi-L curves can be supplied for noise reduction and high PV limits.
- Magnetflex® CIP-curves can be supplied for 'Cleaning In Place' (CIP) applications.

MAGNETFLEX® CURVES



**MAGNETFLEX®
COMBI-A
VERSION C91**

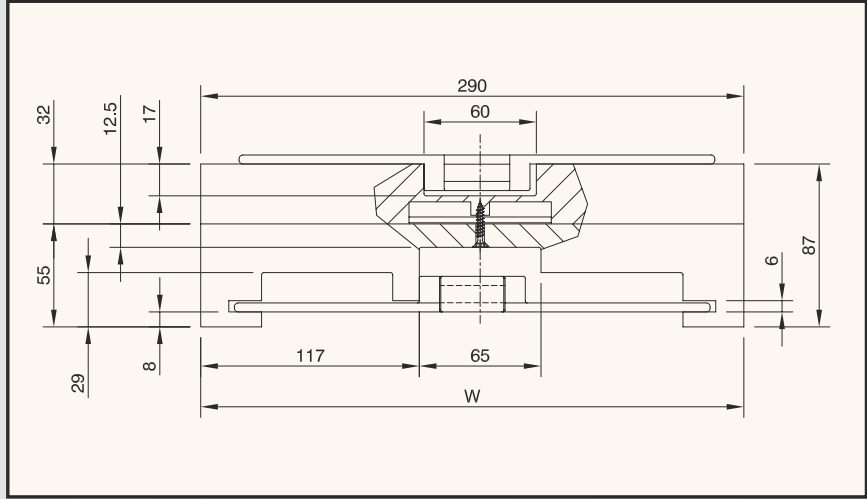

MATERIAL
page 159

page 18, 29

Angle	Code nr.	Width W mm
1 TRACK		
15°	724.42.16	290
30°	724.42.31	
45°	724.42.46	
60°	724.42.61	
75°	724.42.76	
90°	724.42.01	

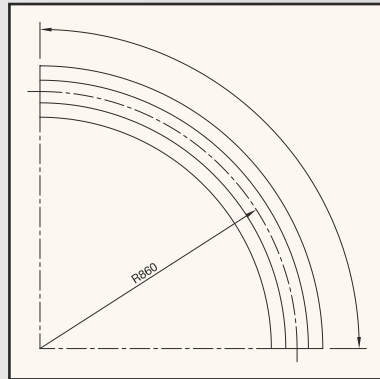

RADIUS

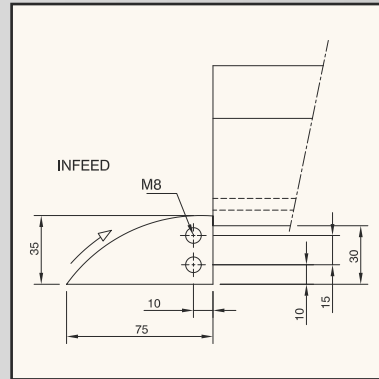

RETURN GUIDE SHOE

For plastic Magnetflex® chains, types:

HDFM 1000 XL
HDFM 1000 SG

More than 1 track on request.

Several Combi-S curves can be supplied for high-speed applications.

MAGNETFLEX® CURVES

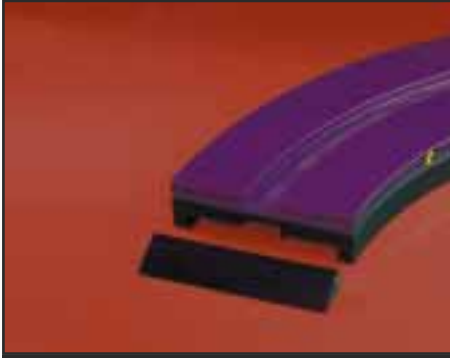

**MAGNETFLEX®
COMBI-A
VERSION C96**

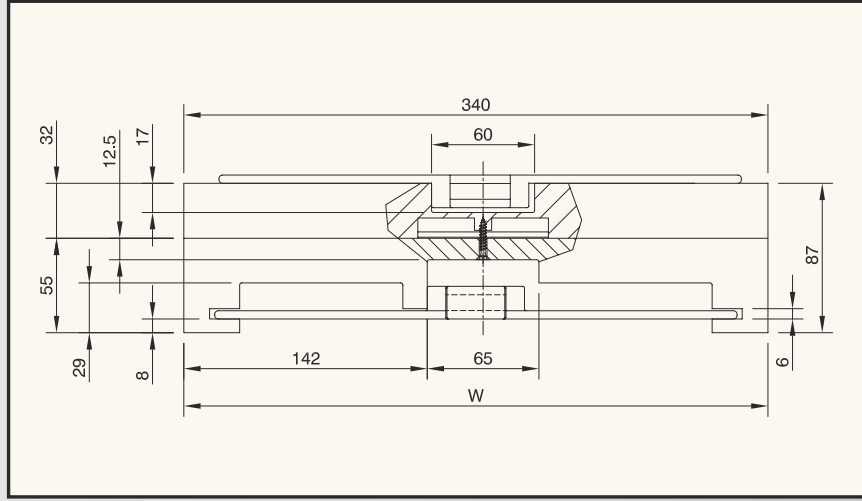

MATERIAL

page 159



page 18, 29

Angle	Code nr.	Width W
		mm
1 TRACK		
15°	724.44.16	340
30°	724.44.31	
45°	724.44.46	
60°	724.44.61	
75°	724.44.76	
90°	724.44.01	

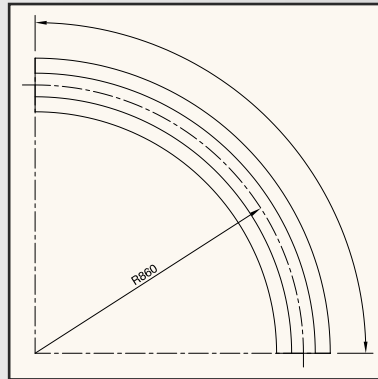

RADIUS

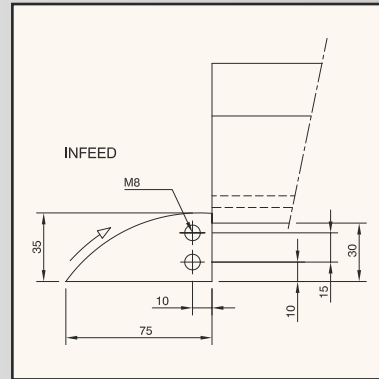

RETURN GUIDE SHOE

For plastic
Magnetflex® chains,
types:

HDFM 1200 XL
HDFM 1200 SG

More than 1 track on request.

Several Combi-S curves can be supplied for high-speed applications.

MAGNETFLEX® CURVES

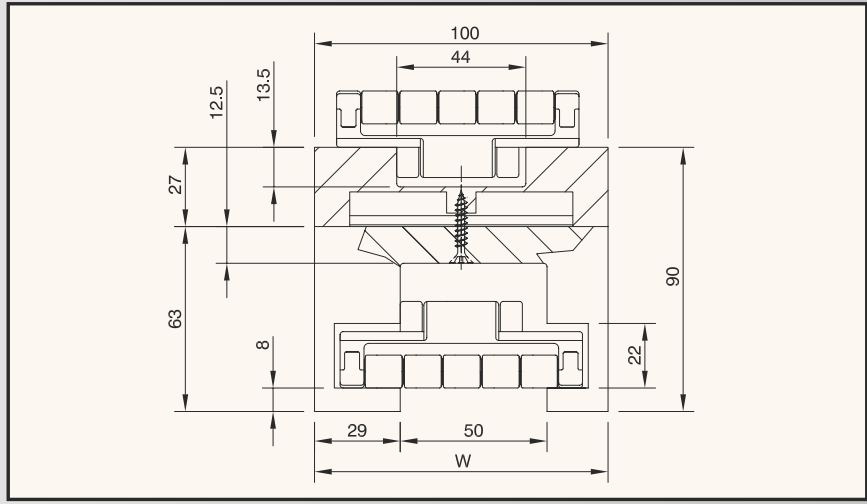

MATERIAL
page 159

page 23

Angle	Code nr.	Width W
		mm
1 TRACK		
15°	704.34.16	100
30°	704.34.31	
45°	704.34.46	
60°	704.34.61	
75°	704.34.76	
90°	704.34.01	
2 TRACKS		
15°	704.34.17	190
30°	704.34.32	
45°	704.34.47	
60°	704.34.62	
75°	704.34.77	
90°	704.34.02	
3 TRACKS		
15°	704.34.18	280
30°	704.34.33	
45°	704.34.48	
60°	704.34.63	
75°	704.34.78	
90°	704.34.03	
4 TRACKS		
15°	704.34.19	370
30°	704.34.34	
45°	704.34.49	
60°	704.34.64	
75°	704.34.79	
90°	704.34.04	
5 TRACKS		
15°	704.34.20	460
30°	704.34.35	
45°	704.34.50	
60°	704.34.65	
75°	704.34.80	
90°	704.34.05	
6 TRACKS		
15°	704.34.21	550
30°	704.34.36	
45°	704.34.51	
60°	704.34.66	
75°	704.34.81	
90°	704.34.06	

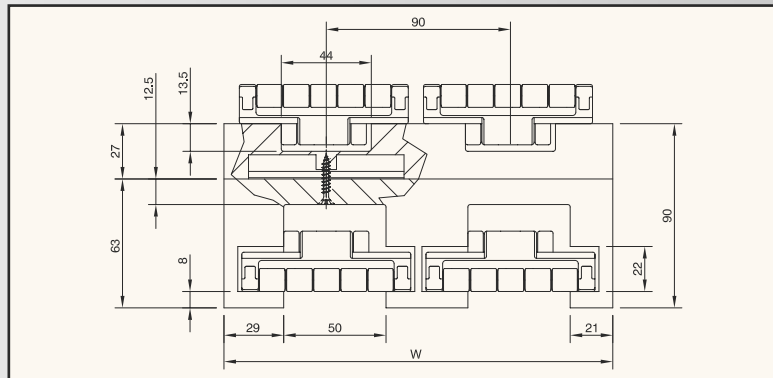

CURVE DIMENSIONS FOR MULTITRACK CURVES

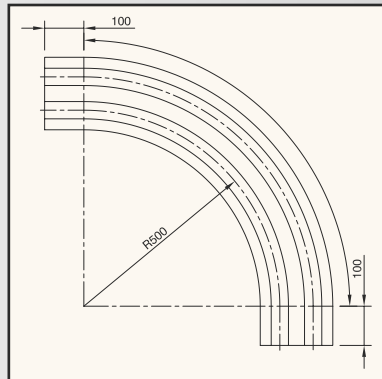

RADIUS

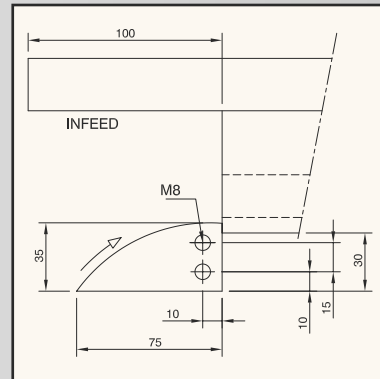

RETURN GUIDE SHOE

For plastic Magnetflex® chains, type:

RHMD 325 LBP

More than 6 tracks on request.

Magnetflex® curves can be supplied with M8 or M10 brass inserts to your detailed drawing.

A wide range of Magnetflex® curves with non-standard dimensions can be supplied.

Several Combi-S curves can be supplied for high-speed applications.

MAGNETFLEX® CURVES

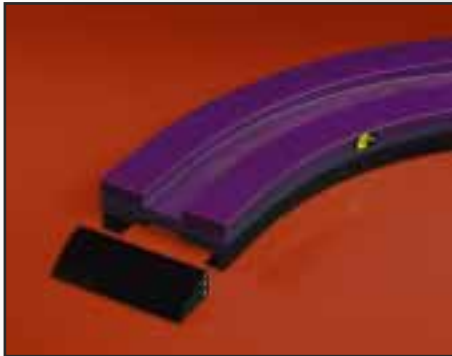

**MAGNETFLEX®
COMBI-A
VERSION LBP861**

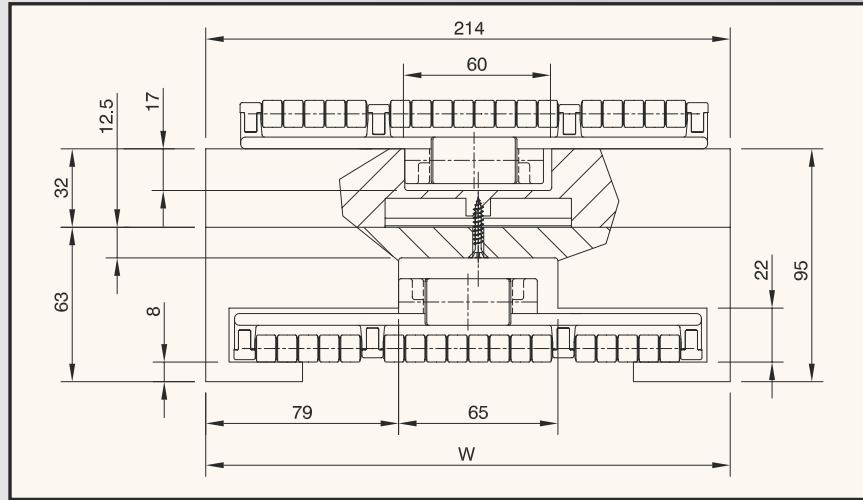

MATERIAL

page 159



page 24

Angle	Code nr.	Width W mm
1 TRACK		
15°	724.47.16	214
30°	724.47.31	
45°	724.47.46	
60°	724.47.61	
75°	724.47.76	
90°	724.47.01	

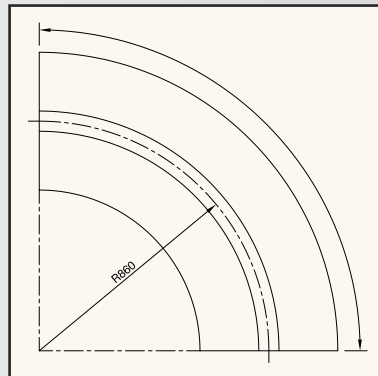

RADIUS

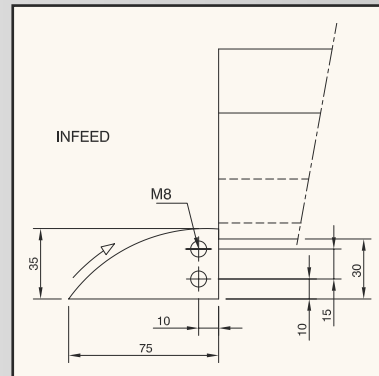

RETURN GUIDE SHOE

For plastic Magnetflex® chains, type:

HDFM 750 LBP

More than 1 track on request.



**MAGNETFLEX®
COMBI-A
VERSION LBP91**

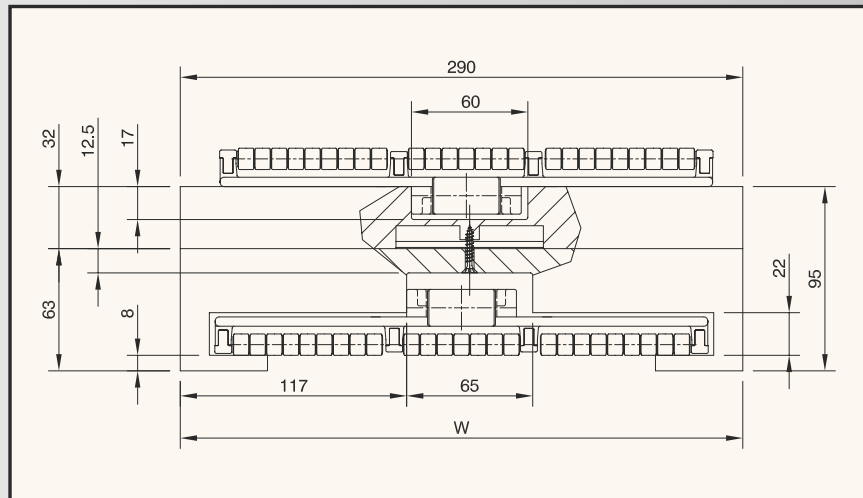

MATERIAL

page 159



page 24

Angle	Code nr.	Width W mm
1 TRACK		
15°	724.45.16	290
30°	724.45.31	
45°	724.45.46	
60°	724.45.61	
75°	724.45.76	
90°	724.45.01	

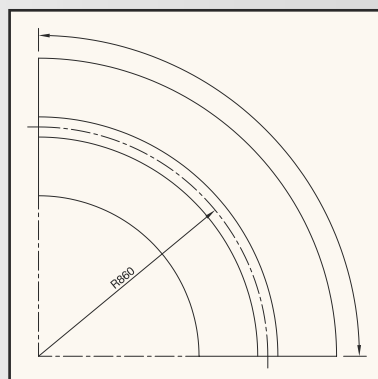

RADIUS

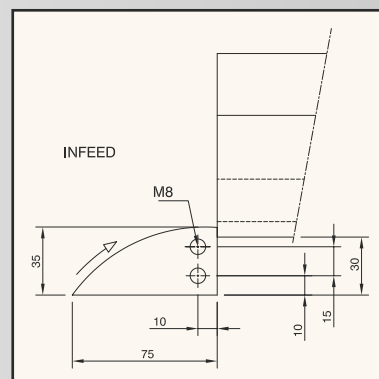

RETURN GUIDE SHOE

For plastic Magnetflex® chains, type:

HDFM 1000 LBP

More than 1 track on request.

Magnetflex® curves can be supplied with M8 or M10 brass inserts to your detailed drawing.

A wide range of Magnetflex® curves with non-standard dimensions can be supplied.

Several Combi-S curves can be supplied for high-speed applications.

MAGNETFLEX® CURVES

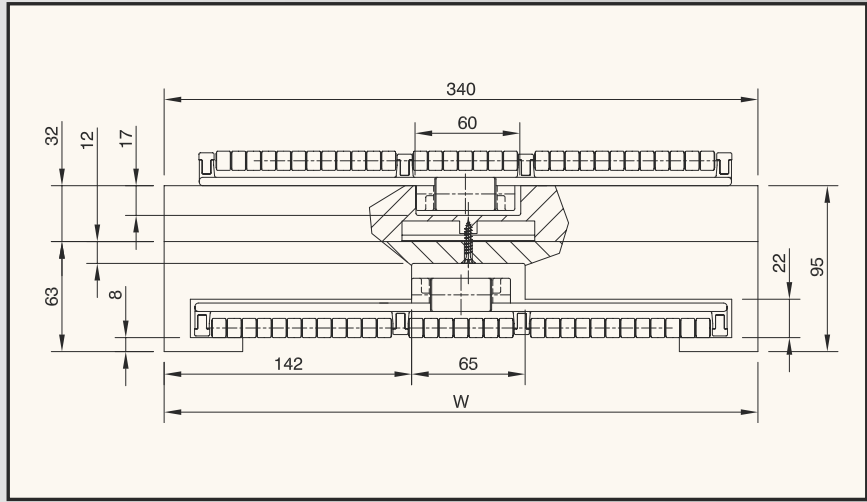

MATERIAL
page 159

page 24

Angle	Code nr.	Width W mm
1 TRACK		
15°	724.46.16	340
30°	724.46.31	
45°	724.46.46	
60°	724.46.61	
75°	724.46.76	
90°	724.46.01	

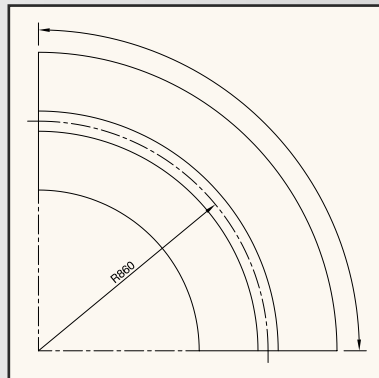

RADIUS

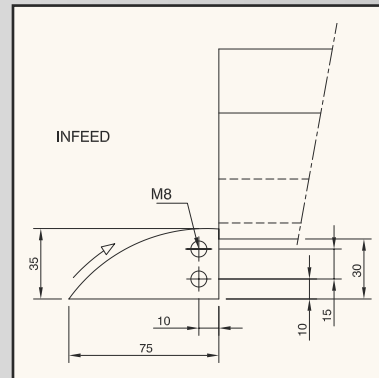

RETURN GUIDE SHOE

For plastic Magnetflex® chains,
type:
HDFM 1200 LBP

More than 1 track on request.

Magnetflex® curves can be supplied with M8 or M10 brass inserts to your detailed drawing.

A wide range of Magnetflex® curves with non-standard dimensions can be supplied.

Several Combi-S curves can be supplied for high-speed applications.

MAGNETFLEX® CURVES



**MAGNETFLEX®
VERSION CIP4**

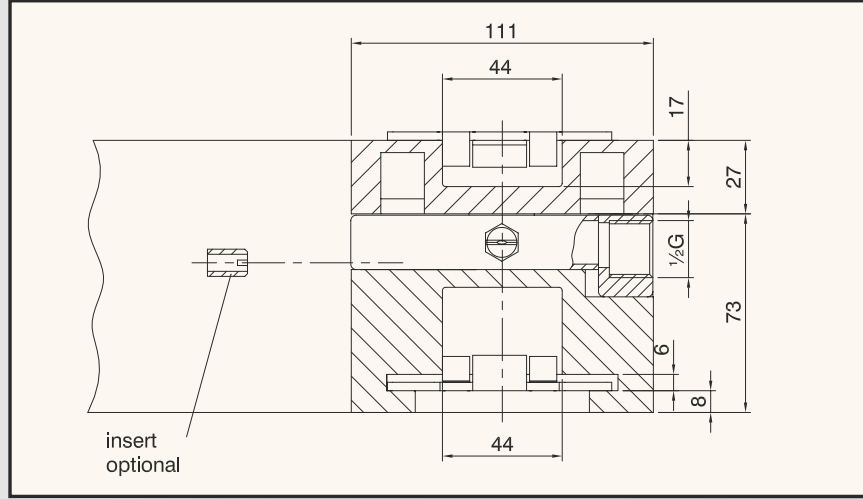

MATERIAL

page 159



page 6, 11

Angle	Code nr.	Width W
		mm
1 TRACK		
15°	785.45.16	111
30°	785.45.31	
45°	785.45.46	
60°	785.45.61	
75°	785.45.76	
90°	785.45.01	
2 TRACKS		
15°	785.45.17	196
30°	785.45.32	
45°	785.45.47	
60°	785.45.62	
75°	785.45.77	
90°	785.45.02	
3 TRACKS		
15°	785.45.18	281
30°	785.45.33	
45°	785.45.48	
60°	785.45.63	
75°	785.45.78	
90°	785.45.03	
4 TRACKS		
15°	785.45.19	366
30°	785.45.34	
45°	785.45.49	
60°	785.45.64	
75°	785.45.79	
90°	785.45.04	
5 TRACKS		
15°	785.45.20	451
30°	785.45.35	
45°	785.45.50	
60°	785.45.65	
75°	785.45.80	
90°	785.45.05	
6 TRACKS		
15°	785.45.21	536
30°	785.45.36	
45°	785.45.51	
60°	785.45.66	
75°	785.45.81	
90°	785.45.06	

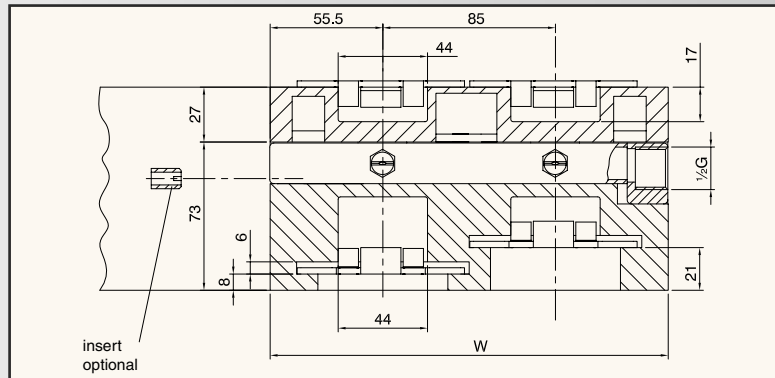

CURVE DIMENSIONS FOR MULTITRACK CURVES

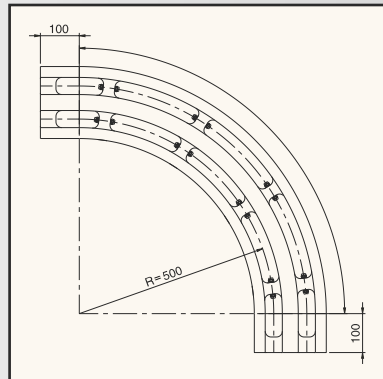

RADIUS

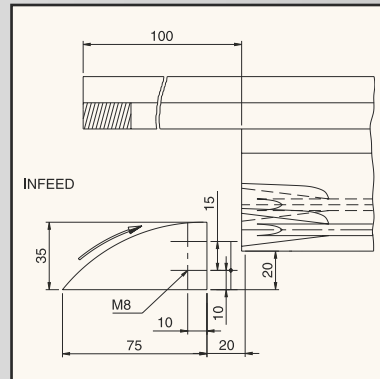

RETURN GUIDE SHOE

For (stainless) steel Magnetflex® chains, types:

- 10 M 31 M
- 45 M 31 M
- 60 M 31 (S)M
- 60 M 31 RM
- 60 M 84 SM

More than 6 tracks on request.

Magnetflex® curves can be supplied with M8 or M10 brass inserts to your detailed drawing.

A wide range of Magnetflex® curves with non-standard dimensions can be supplied.

Several Combi-G curves can be supplied for extremely abrasive applications.

MAGNETFLEX® CURVES



MAGNETFLEX®
VERSION CIP6

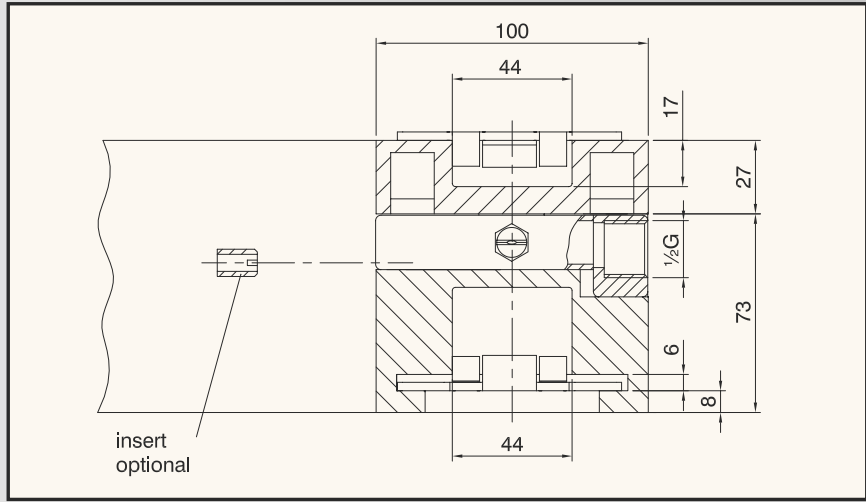

MATERIAL
page 159

page 6, 11

Angle	Code nr.	Width W
		mm
1 TRACK		
15°	785.43.16	100
30°	785.43.31	
45°	785.43.46	
60°	785.43.61	
75°	785.43.76	
90°	785.43.01	
2 TRACKS		
15°	785.43.17	185
30°	785.43.32	
45°	785.43.47	
60°	785.43.62	
75°	785.43.77	
90°	785.43.02	
3 TRACKS		
15°	785.43.18	270
30°	785.43.33	
45°	785.43.48	
60°	785.43.63	
75°	785.43.78	
90°	785.43.03	
4 TRACKS		
15°	785.43.19	355
30°	785.43.34	
45°	785.43.49	
60°	785.43.64	
75°	785.43.79	
90°	785.43.04	
5 TRACKS		
15°	785.43.20	440
30°	785.43.35	
45°	785.43.50	
60°	785.43.65	
75°	785.43.80	
90°	785.43.05	
6 TRACKS		
15°	785.43.21	525
30°	785.43.36	
45°	785.43.51	
60°	785.43.66	
75°	785.43.81	
90°	785.43.06	

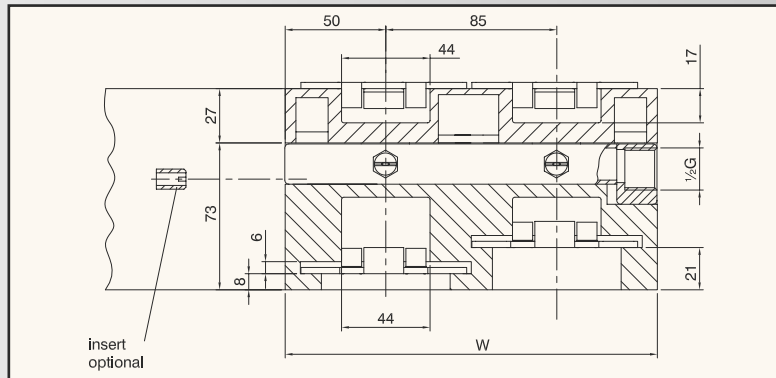

CURVE DIMENSIONS FOR MULTITRACK CURVES

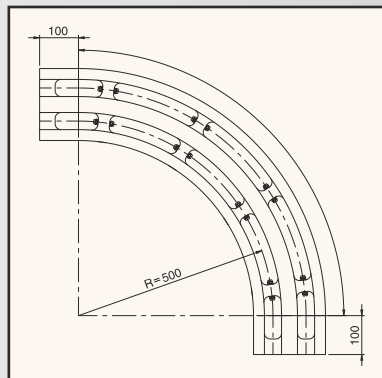

RADIUS

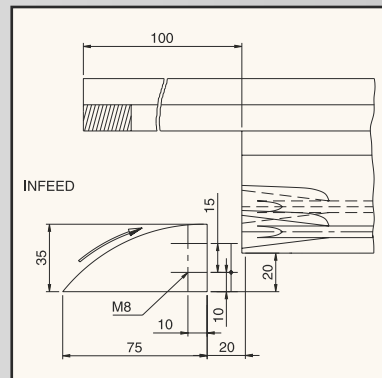

RETURN GUIDE SHOE

For (stainless) steel Magnetflex® chains, types:

- 10 M 31 M
- 45 M 31 M
- 60 M 31 (S)M
- 60 M 31 RM
- 60 M 84 SM

More than 6 tracks on request.

Magnetflex® curves can be supplied with M8 or M10 brass inserts to your detailed drawing.

A wide range of Magnetflex® curves with non-standard dimensions can be supplied.

Several Combi-G curves can be supplied for extremely abrasive applications.

MAGNETFLEX® CURVES



**MAGNETFLEX®
COMBI-A
VERSION CB4**

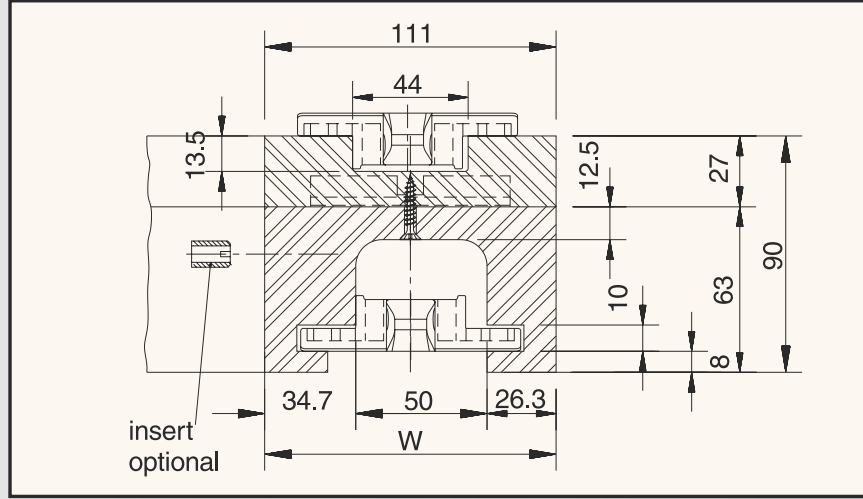

MATERIAL

page 159



page 67, 68

Angle	Code nr.	Width W
		mm
1 TRACK		
15°	604.08.16	111
30°	604.08.31	
45°	604.08.46	
60°	604.08.61	
75°	604.08.76	
90°	604.08.01	
2 TRACKS		
15°	604.08.17	196
30°	604.08.32	
45°	604.08.47	
60°	604.08.62	
75°	604.08.77	
90°	604.08.02	
3 TRACKS		
15°	604.08.18	281
30°	604.08.33	
45°	604.08.48	
60°	604.08.63	
75°	604.08.78	
90°	604.08.03	
4 TRACKS		
15°	604.08.19	366
30°	604.08.34	
45°	604.08.49	
60°	604.08.64	
75°	604.08.79	
90°	604.08.04	
5 TRACKS		
15°	604.08.20	451
30°	604.08.35	
45°	604.08.50	
60°	604.08.65	
75°	604.08.80	
90°	604.08.05	
6 TRACKS		
15°	604.08.21	536
30°	604.08.36	
45°	604.08.51	
60°	604.08.66	
75°	604.08.81	
90°	604.08.06	

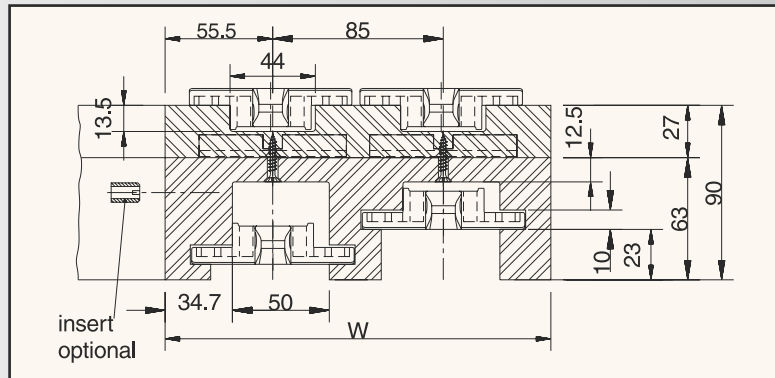

CURVE DIMENSIONS FOR MULTITRACK CURVES

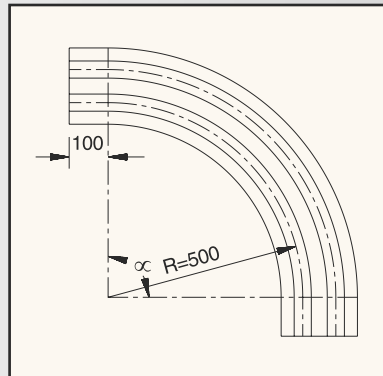

RADIUS

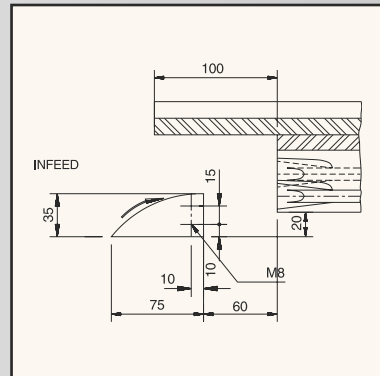

RETURN GUIDE SHOE

For Magnetflex®
chainbelts,
types:

FGM 1050 XLG
FGM 1050 XS
FTM 1050 XLG
FTM 1050 XS

More than 6 tracks on request.

Magnetflex® curves can be supplied with M8 or M10 brass inserts to your detailed drawing.

A wide range of Magnetflex® curves with non-standard dimensions can be supplied.

Several Combi-S curves can be supplied for high-speed applications.

MAGNETFLEX® CURVES

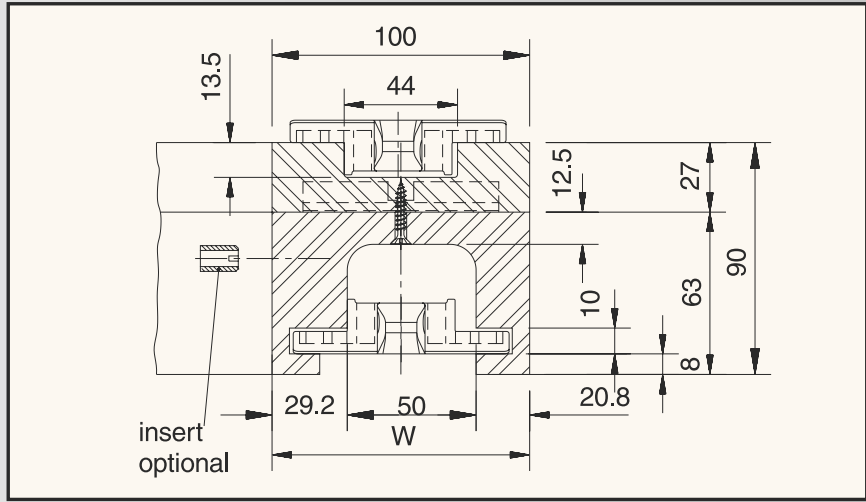

MATERIAL
page 159

page 67, 68

Angle	Code nr.	Width W
		mm
1 TRACK		
15°	604.14.16	100
30°	604.14.31	
45°	604.14.46	
60°	604.14.61	
75°	604.14.76	
90°	604.14.01	
2 TRACKS		
15°	604.14.17	185
30°	604.14.32	
45°	604.14.47	
60°	604.14.62	
75°	604.14.77	
90°	604.14.02	
3 TRACKS		
15°	604.14.18	270
30°	604.14.33	
45°	604.14.48	
60°	604.14.63	
75°	604.14.78	
90°	604.14.03	
4 TRACKS		
15°	604.14.19	355
30°	604.14.34	
45°	604.14.49	
60°	604.14.64	
75°	604.14.79	
90°	604.14.04	
5 TRACKS		
15°	604.14.20	440
30°	604.14.35	
45°	604.14.50	
60°	604.14.65	
75°	604.14.80	
90°	604.14.05	
6 TRACKS		
15°	604.14.21	525
30°	604.14.36	
45°	604.14.51	
60°	604.14.66	
75°	604.14.81	
90°	604.14.06	

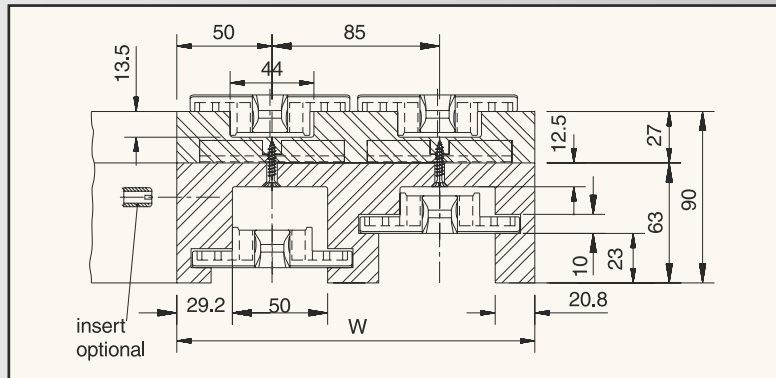

CURVE DIMENSIONS FOR MULTITRACK CURVES

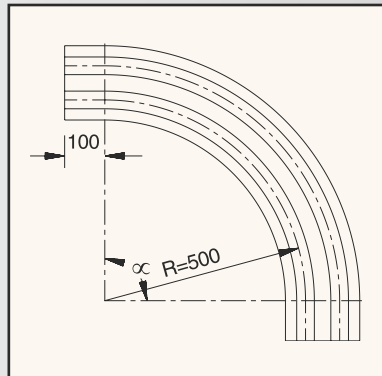

RADIUS

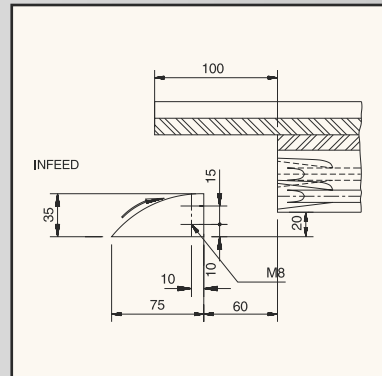

RETURN GUIDE SHOE

For Magnetflex® chainbelts, types:

- FGM 1050 XLG
- FGM 1050 XS
- FTM 1050 XLG
- FTM 1050 XS

More than 6 tracks on request.

Magnetflex® curves can be supplied with M8 or M10 brass inserts to your detailed drawing.

A wide range of Magnetflex® curves with non-standard dimensions can be supplied.

Several Combi-S curves can be supplied for high-speed applications.

MAGNETFLEX® CURVES



**MAGNETFLEX®
COMBI-A
VERSION CB7**

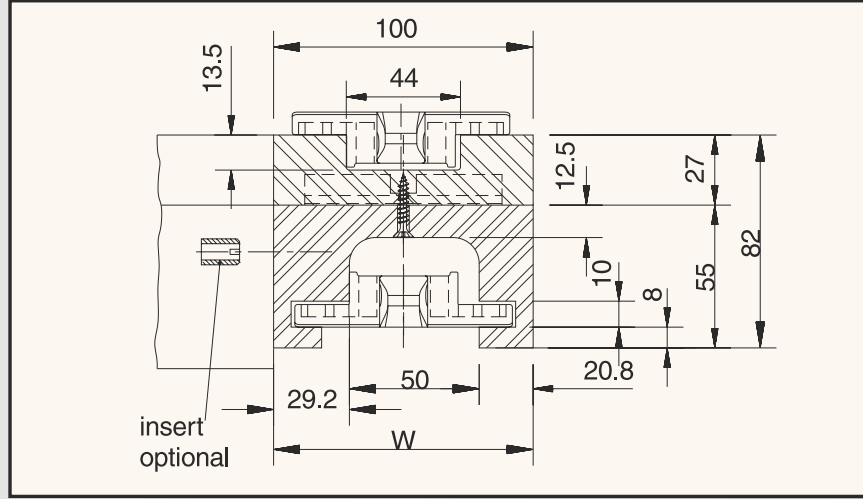

MATERIAL

page 159



page 67, 68

Angle	Code nr.	Width W
		mm
1 TRACK		
15°	604.15.16	100
30°	604.15.31	
45°	604.15.46	
60°	604.15.61	
75°	604.15.76	
90°	604.15.01	
2 TRACKS		
15°	604.15.17	185
30°	604.15.32	
45°	604.15.47	
60°	604.15.62	
75°	604.15.77	
90°	604.15.02	
3 TRACKS		
15°	604.15.18	270
30°	604.15.33	
45°	604.15.48	
60°	604.15.63	
75°	604.15.78	
90°	604.15.03	
4 TRACKS		
15°	604.15.19	355
30°	604.15.34	
45°	604.15.49	
60°	604.15.64	
75°	604.15.79	
90°	604.15.04	
5 TRACKS		
15°	604.15.20	440
30°	604.15.35	
45°	604.15.50	
60°	604.15.65	
75°	604.15.80	
90°	604.15.05	
6 TRACKS		
15°	604.15.21	525
30°	604.15.36	
45°	604.15.51	
60°	604.15.66	
75°	604.15.81	
90°	604.15.06	

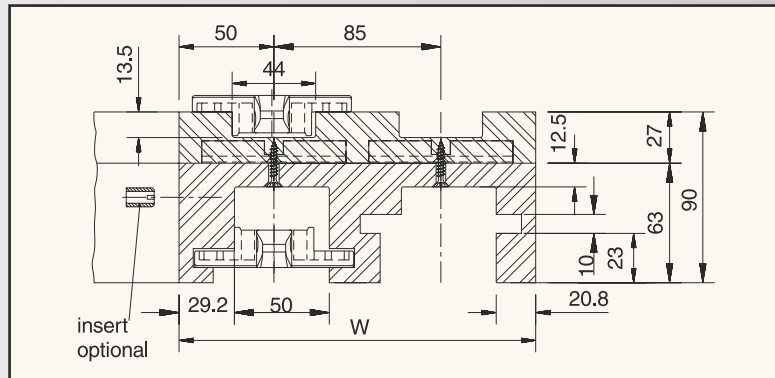

CURVE DIMENSIONS FOR MULTITRACK CURVES

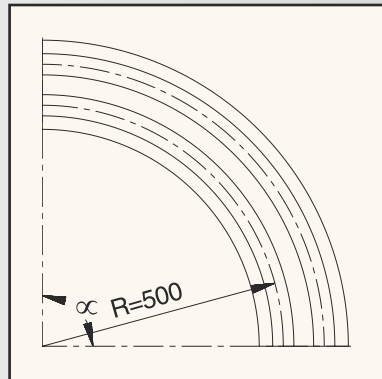

RADIUS

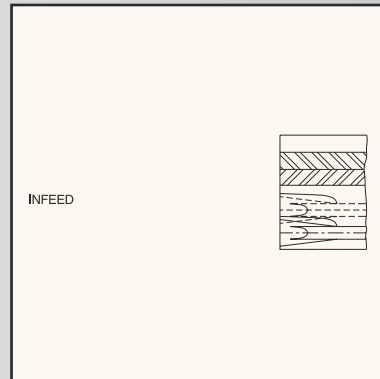

RETURN GUIDE SHOE NOT INCLUDED

For Magnetflex®
chainbelts,
types:

FGM 1050 XLG
FGM 1050 XS
FTM 1050 XLG
FTM 1050 XS

More than 6 tracks on request.

Magnetflex® curves can be supplied with M8 or M10 brass inserts to your detailed drawing.

A wide range of Magnetflex® curves with non-standard dimensions can be supplied.

Several Combi-S curves can be supplied for high-speed applications.

MAGNETFLEX® CURVES

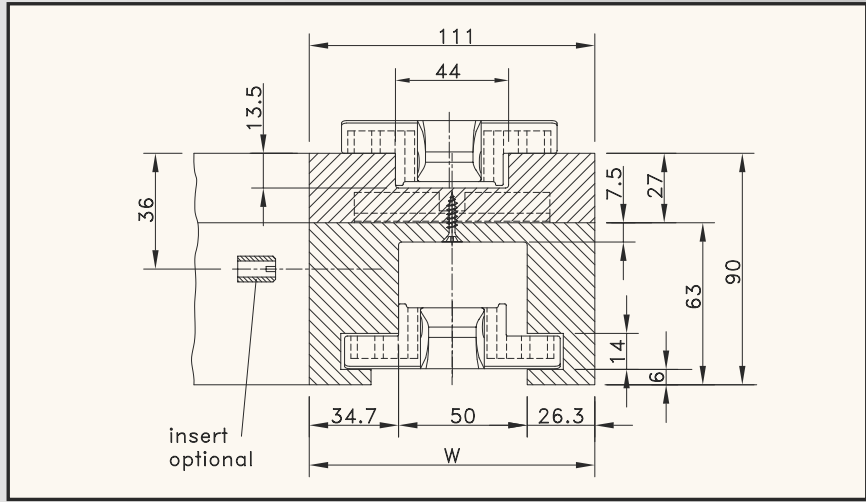

MATERIAL
page 159

page 69

Angle	Code nr.	Width W
		mm
1 TRACK		
15°	614.01.16	111
30°	614.01.31	
45°	614.01.46	
60°	614.01.61	
75°	614.01.76	
90°	614.01.01	
2 TRACKS		
15°	614.01.17	196
30°	614.01.32	
45°	614.01.47	
60°	614.01.62	
75°	614.01.77	
90°	614.01.02	
3 TRACKS		
15°	614.01.18	281
30°	614.01.33	
45°	614.01.48	
60°	614.01.63	
75°	614.01.78	
90°	614.01.03	
4 TRACKS		
15°	614.01.19	366
30°	614.01.34	
45°	614.01.49	
60°	614.01.64	
75°	614.01.79	
90°	614.01.04	
5 TRACKS		
15°	614.01.20	451
30°	614.01.35	
45°	614.01.50	
60°	614.01.65	
75°	614.01.80	
90°	614.01.05	
6 TRACKS		
15°	614.01.21	536
30°	614.01.36	
45°	614.01.51	
60°	614.01.66	
75°	614.01.81	
90°	614.01.06	

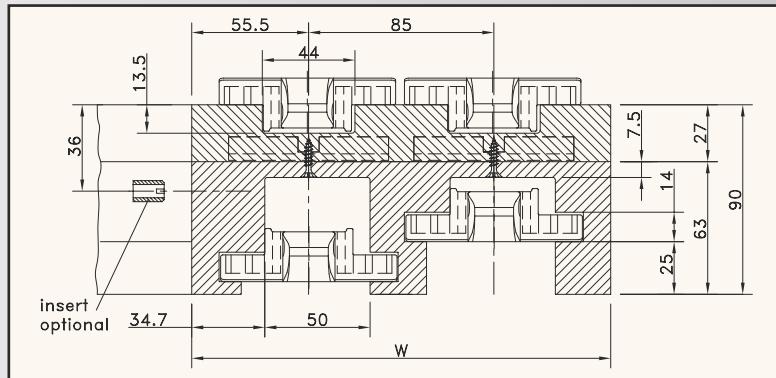

CURVE DIMENSIONS FOR MULTITRACK CURVES

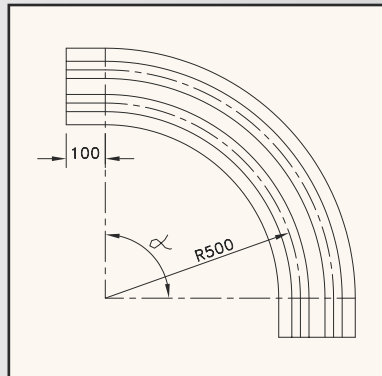

RADIUS

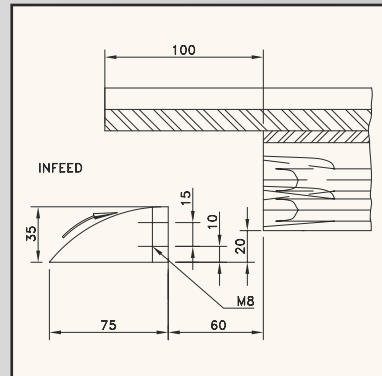

RETURN GUIDE SHOE

For Magnetflex® chainbelts, type:
FTM 1055 XLG K330

More than 6 tracks on request.

Magnetflex® curves can be supplied with M8 or M10 brass inserts to your detailed drawing.

A wide range of Magnetflex® curves with non-standard dimensions can be supplied.

Several Combi-S curves can be supplied for high-speed applications.

MAGNETFLEX® CURVES



**MAGNETFLEX®
COMBI-A
VERSION CC6**

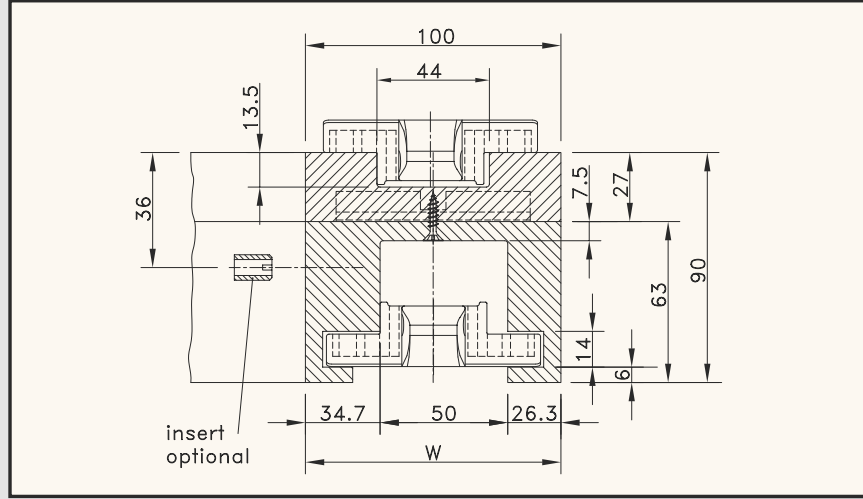

MATERIAL

page 159



page 69

Angle	Code nr.	Width
		W
		mm
1 TRACK		
15°	614.02.16	100
30°	614.02.31	
45°	614.02.46	
60°	614.02.61	
75°	614.02.76	
90°	614.02.01	
2 TRACKS		
15°	614.02.17	185
30°	614.02.32	
45°	614.02.47	
60°	614.02.62	
75°	614.02.77	
90°	614.02.02	
3 TRACKS		
15°	614.02.18	270
30°	614.02.33	
45°	614.02.48	
60°	614.02.63	
75°	614.02.78	
90°	614.02.03	
4 TRACKS		
15°	614.02.19	355
30°	614.02.34	
45°	614.02.49	
60°	614.02.64	
75°	614.02.79	
90°	614.02.04	
5 TRACKS		
15°	614.02.20	440
30°	614.02.35	
45°	614.02.50	
60°	614.02.65	
75°	614.02.80	
90°	614.02.05	
6 TRACKS		
15°	614.02.21	525
30°	614.02.36	
45°	614.02.51	
60°	614.02.66	
75°	614.02.81	
90°	614.02.06	

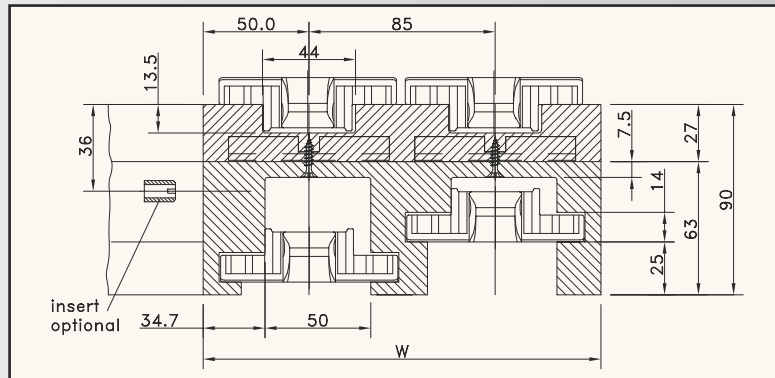

CURVE DIMENSIONS FOR MULTITRACK CURVES

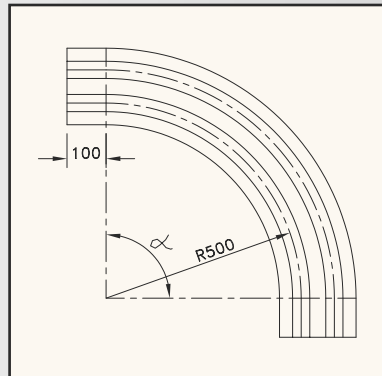

RADIUS

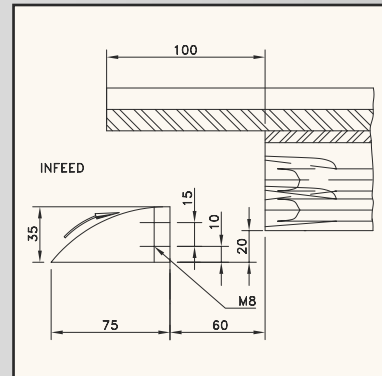

RETURN GUIDE SHOE

For Magnetflex®
chainbelts,
type:
FTM 1055 XLG K330

More than 6 tracks on request.

Magnetflex® curves can be supplied with M8 or M10 brass inserts to your detailed drawing.

A wide range of Magnetflex® curves with non-standard dimensions can be supplied.

Several Combi-S curves can be supplied for high-speed applications.

MAGNETFLEX® CURVES

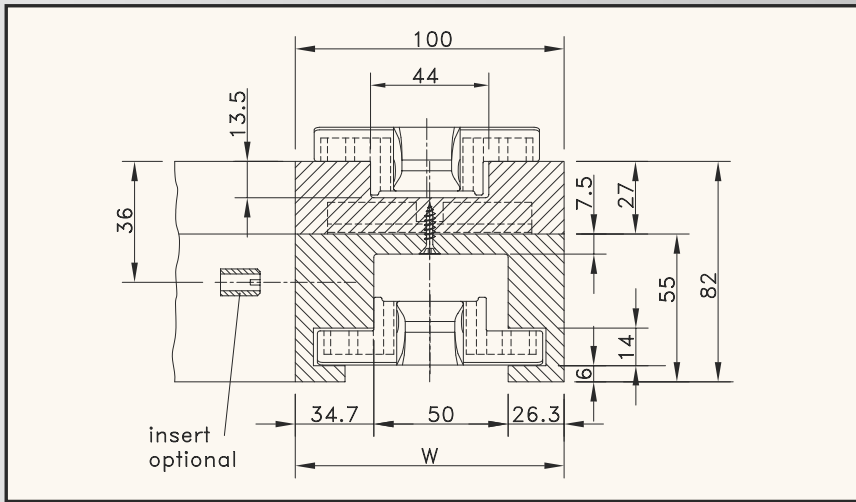

MATERIAL
page 159

page 69

Angle	Code nr.	Width W
		mm
1 TRACK		
15°	614.06.16	100
30°	614.06.31	
45°	614.06.46	
60°	614.06.61	
75°	614.06.76	
90°	614.06.01	
2 TRACKS		
15°	614.06.17	185
30°	614.06.32	
45°	614.06.47	
60°	614.06.62	
75°	614.06.77	
90°	614.06.02	
3 TRACKS		
15°	614.06.18	270
30°	614.06.33	
45°	614.06.48	
60°	614.06.63	
75°	614.06.78	
90°	614.06.03	
4 TRACKS		
15°	614.06.19	355
30°	614.06.34	
45°	614.06.49	
60°	614.06.64	
75°	614.06.79	
90°	614.06.04	
5 TRACKS		
15°	614.06.20	440
30°	614.06.35	
45°	614.06.50	
60°	614.06.65	
75°	614.06.80	
90°	614.06.05	
6 TRACKS		
15°	614.06.21	525
30°	614.06.36	
45°	614.06.51	
60°	614.06.66	
75°	614.06.81	
90°	614.06.06	

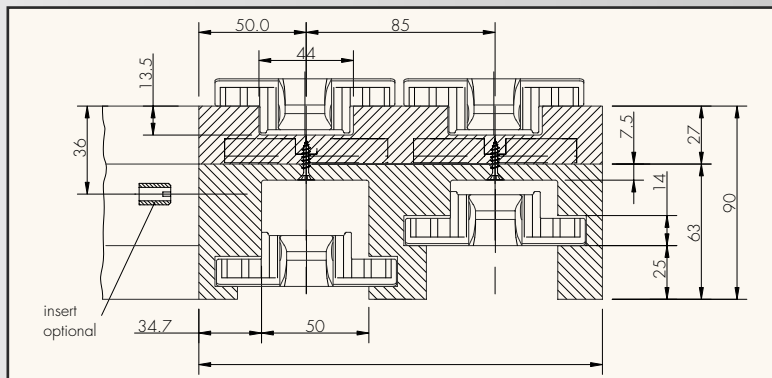

CURVE DIMENSIONS FOR MULTITRACK CURVES

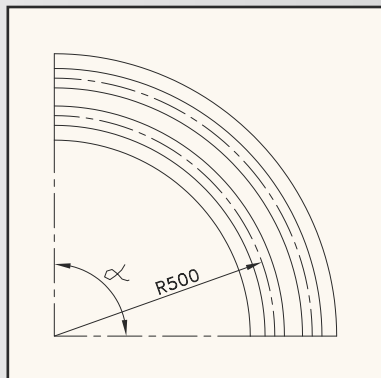

RADIUS

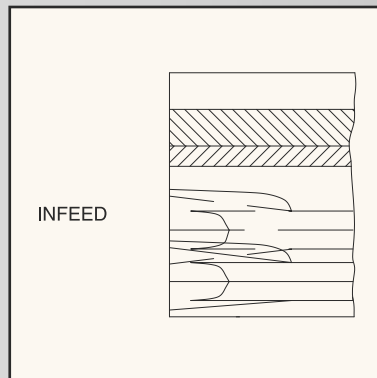

RETURN GUIDE SHOE NOT INCLUDED

For Magnetflex®
chainbelts,
type:
FTM 1055 XLG K330

More than 6 tracks on request.

Magnetflex® curves can be supplied with M8 or M10 brass inserts to your detailed drawing.

A wide range of Magnetflex® curves with non-standard dimensions can be supplied.

Several Combi-S curves can be supplied for high-speed applications.

MAGNETFLEX® CURVES



**MAGNETFLEX®
COMBI-A
VERSION CC21**

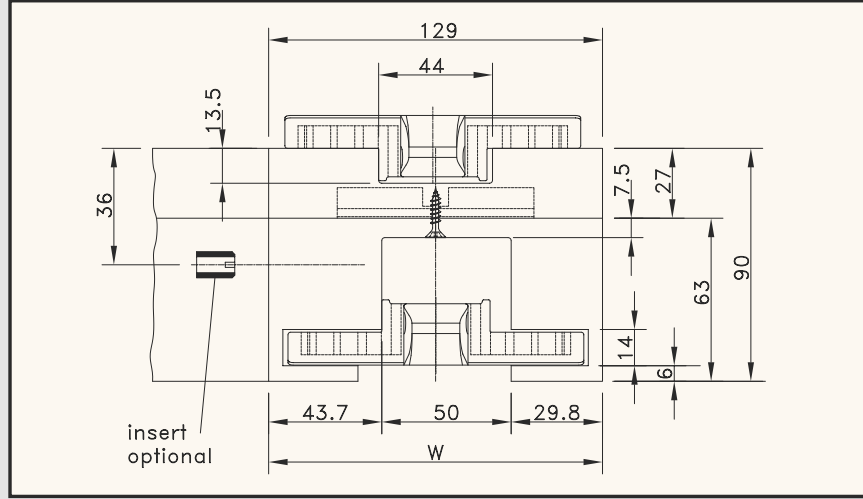

MATERIAL

page 159



page 69

Angle	Code nr.	Width W
		mm
1 TRACK		
15°	614.08.16	129
30°	614.08.31	
45°	614.08.46	
60°	614.08.61	
75°	614.08.76	
90°	614.08.01	
2 TRACKS		
15°	614.08.17	249
30°	614.08.32	
45°	614.08.47	
60°	614.08.62	
75°	614.08.77	
90°	614.08.02	
3 TRACKS		
15°	614.08.18	369
30°	614.08.33	
45°	614.08.48	
60°	614.08.63	
75°	614.08.78	
90°	614.08.03	
4 TRACKS		
15°	614.08.19	489
30°	614.08.34	
45°	614.08.49	
60°	614.08.64	
75°	614.08.79	
90°	614.08.04	

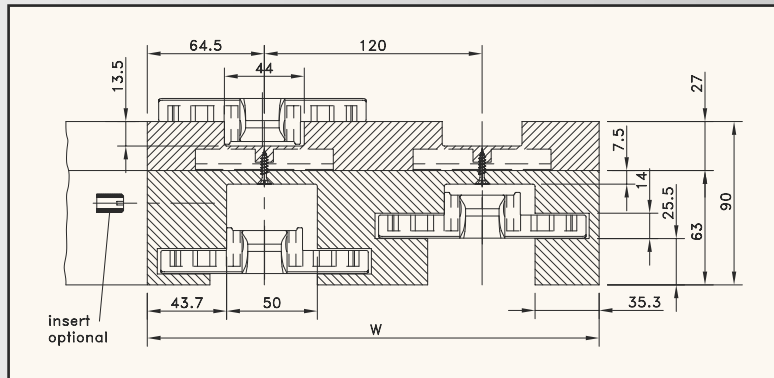

CURVE DIMENSIONS FOR MULTITRACK CURVES

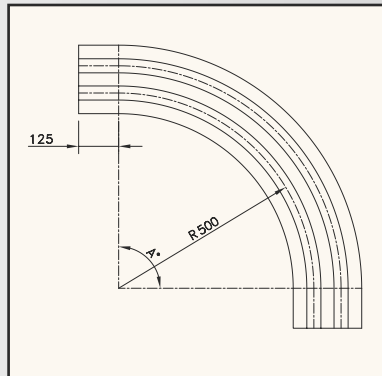

RADIUS

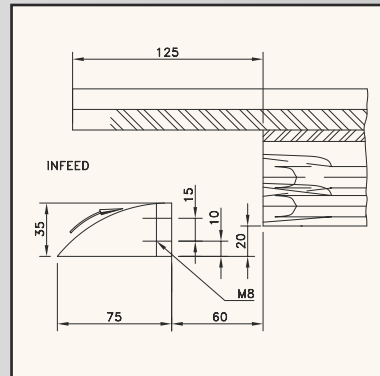

RETURN GUIDE SHOE

For Magnetflex®
chainbelts,
type:
FTM 1055 XLG K450

More than 4 tracks on request.

Magnetflex® curves can be supplied with M8 or M10 brass inserts to your detailed drawing.

A wide range of Magnetflex® curves with non-standard dimensions can be supplied.

Several Combi-S curves can be supplied for high-speed applications.

MAGNETFLEX® CURVES

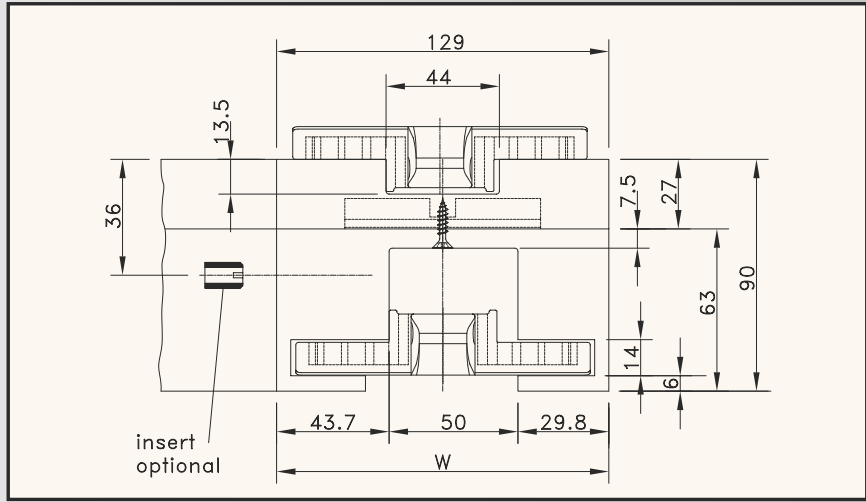

MATERIAL
page 159

page 69

Angle	Code nr.	Width W
		mm
1 TRACK		
15°	614.09.16	129
30°	614.09.31	
45°	614.09.46	
60°	614.09.61	
75°	614.09.76	
90°	614.09.01	
2 TRACKS		
15°	614.09.17	249
30°	614.09.32	
45°	614.09.47	
60°	614.09.62	
75°	614.09.77	
90°	614.09.02	
3 TRACKS		
15°	614.09.18	369
30°	614.09.33	
45°	614.09.48	
60°	614.09.63	
75°	614.09.78	
90°	614.09.03	
4 TRACKS		
15°	614.09.19	489
30°	614.09.34	
45°	614.09.49	
60°	614.09.64	
75°	614.09.79	
90°	614.09.04	

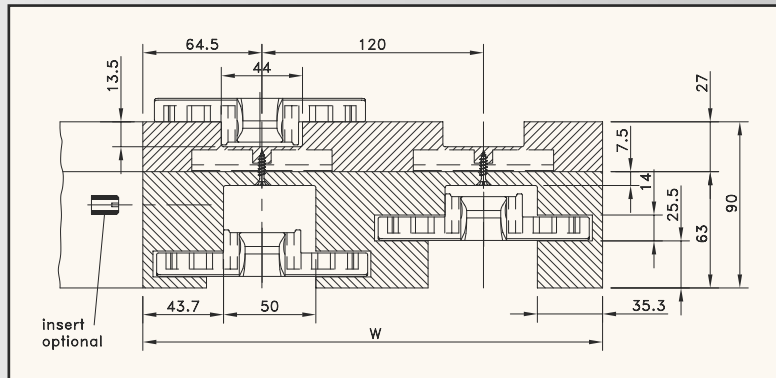

CURVE DIMENSIONS FOR MULTITRACK CURVES

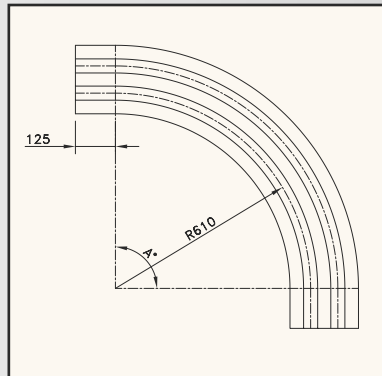

RADIUS

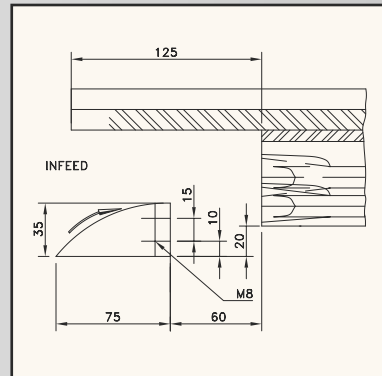

RETURN GUIDE SHOE

For Magnetflex®
chainbelts,
type:
FTM 1055 XLG K450

More than 4 tracks on request.

Magnetflex® curves can be supplied with M8 or M10 brass inserts to your detailed drawing.

A wide range of Magnetflex® curves with non-standard dimensions can be supplied.

Several Combi-S curves can be supplied for high-speed applications.

TAB CURVES



**TAB CURVES
WITH SEPARATE
UPPER AND RETURN PART**

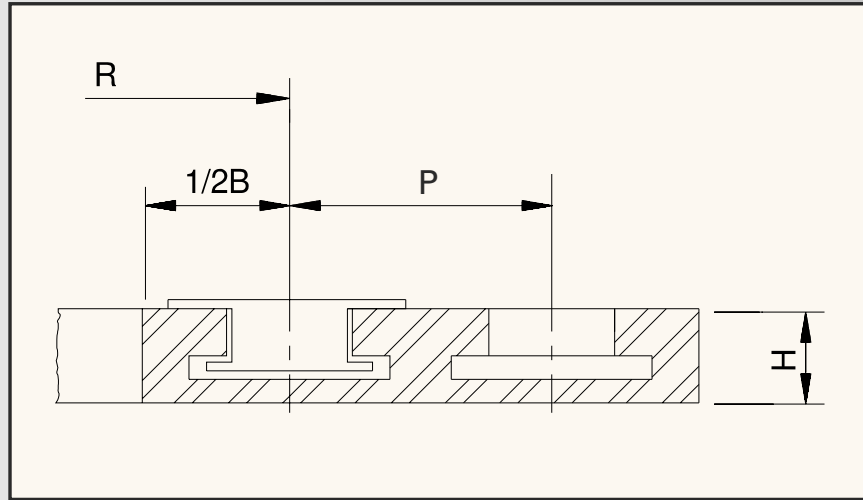

MATERIAL
page 159

For chain types	Code nr.	Radius R	Basic width B	Height H	Nr. of tracks	Pitch P	Curve width	Angle
		mm	mm	mm		mm	mm	
VERSION 501								
PRT(P/D) 200	756.58.01	890	90	25	1	–	90	90°
VERSION 502								
PRT(P/D) 200	756.58.00	1000	90	25	1	–	90	90°
VERSION 503								
PRT(P/D) 200	756.58.02	1110	90	25	1	–	90	90°
VERSION 561								
HDF 375 LBP	776.55.01	680	125	32	1	–	125	90°
	776.55.02	680	125	32	2	100	225	90°
VERSION 571								
HDF 450	776.50.01	610	125	32	1	–	125	90°
	776.50.02	610	125	32	2	120	245	90°
VERSION 576								
HDF 750 (LBP)	776.51.01	610	200	32	1	–	200	90°
	776.51.02	610	200	32	2	195	395	90°
VERSION 581								
HDF 1000 (LBP)	776.52.01	610	265	32	1	–	265	90°
	776.52.02	610	265	32	2	260	525	90°
VERSION 586								
HDF 1200	776.53.01	610	315	32	1	–	315	90°
	776.53.02	610	315	32	2	310	625	90°
VERSION 587								
HDF 1200 LBP	776.56.01	680	315	32	1	–	315	90°
	776.56.02	680	315	32	2	310	625	90°

Other numbers of tracks, different angles and non-standard tab curves on request.

Curves can be supplied with mounted M8 or M10 inserts.

Two parts are required to make one complete curve.

TAB CURVES



**TAB CURVES
WITH COMBINED
UPPER AND RETURN PART**

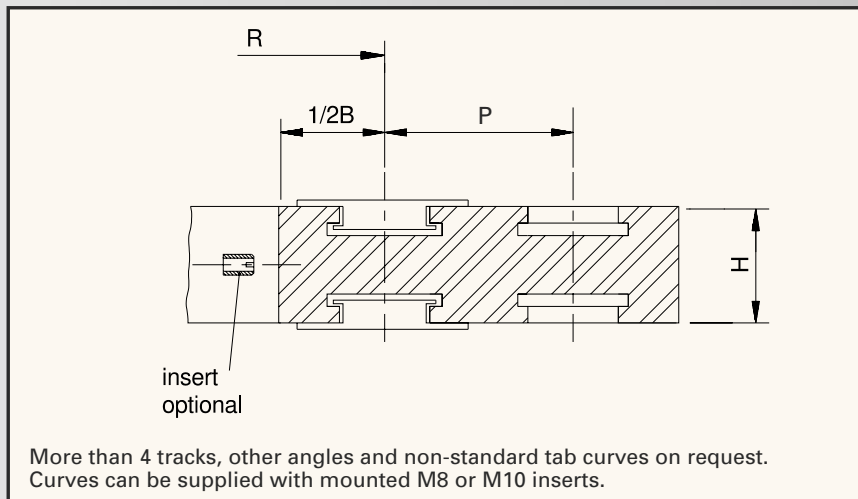

For chain types	Code nr.	Radius R	Basic width B	Height H	Nr. of tracks	Pitch P	Curve width	Angle
		mm	mm	mm		mm	mm	
VERSION 121								
SRH 325	756.32.01	500	100	55	1	-	100	90°
	756.32.02	500	100	55	2	89	189	90°
	756.32.03	500	100	55	3	89	278	90°
	756.32.04	500	100	55	4	89	367	90°
VERSION 141								
RH(D) 325 60 T 31 M	756.34.01	500	100	55	1	-	100	90°
	756.34.02	500	100	55	2	89	189	90°
	756.34.03	500	100	55	3	89	278	90°
	756.34.04	500	100	55	4	89	367	90°
VERSION 161								
RH(D) 450 60 T 42 M	756.36.01	500	129	55	1	-	129	90°
	756.36.02	500	129	55	2	120	249	90°
	756.36.03	500	129	55	3	120	369	90°
	756.36.04	500	129	55	4	120	489	90°



**TAB CURVES
WITH SEPARATE
UPPER AND RETURN PART**

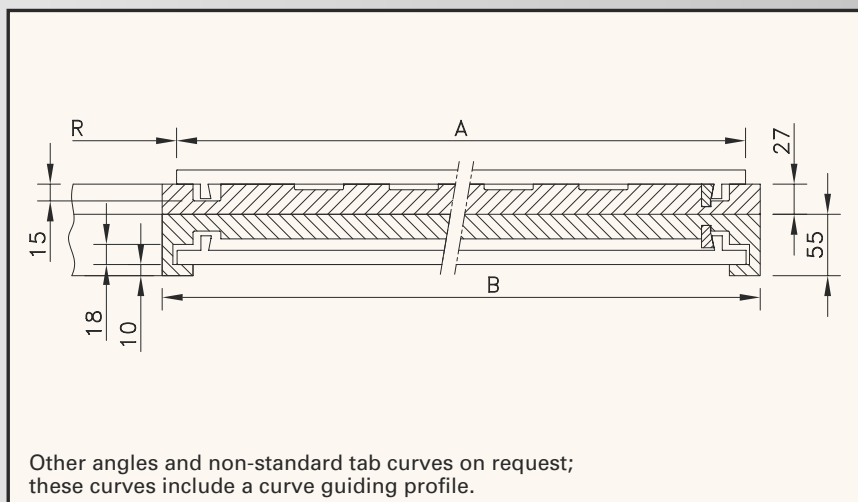

For belt types	Code nr.	Radius R	Belt width A	Height H	Curve width B	Angle
		mm	mm	mm	mm	
VERSION 505						
RBP 505	804.02.02	510	255	27 + 55	281	90°
	804.02.03	680	340	27 + 55	366	90°
	804.02.04	850	425	27 + 55	451	90°
	804.02.05	1020	510	27 + 55	536	90°
	804.02.06	1190	595	27 + 55	621	90°
	804.02.07	1360	680	27 + 55	706	90°
VERSION 1255						
RBP 1255	805.02.02	510	255	27 + 55	281	90°
	805.02.03	680	340	27 + 55	366	90°
	805.02.04	850	425	27 + 55	451	90°
	805.02.05	1020	510	27 + 55	536	90°
	805.02.06	1190	595	27 + 55	621	90°
	805.02.07	1360	680	27 + 55	706	90°

The split sprockets and idlers consist of two parts, which are easy to assemble by means of two hexagonal bolts. Even if many sprockets are used, access to the bolts is easy with standard tools.



CONVEYOR WITH TIME-SAVING PLASTIC SPLIT SPROCKETS.

BENEFITS

- Easy to install and to remove**
There's no need to remove the bearings or the shaft. Bolts are accessible from one side and other smart features make assembly even easier than common split sprockets.
- Extra long wearlife**
The sprocket rings are made of wear-resistant polyamide.
- Easy to clean**
Flush sides stay cleaner; quick removal makes cleaning easier.
- Optimum engagement**
The special teeth design ensures excellent contact between the chain or belt and the sprocket.

PROGRAMME

- Split sprockets for chains**
Round bore, with keyway.
- Split idlers for chains**
Round bore, without keyway, with teeth.
- Split idler drums for chains**
Round bore, without keyway; no teeth.
- Split sprockets for belts**
Round and square bores.



EASY CLEANING AND INSTALLATION WITH BOTH BOLTS ON THE SAME SIDE.

AND . . .

MCC's split sprockets can replace the classic version in any application. The strength is at least the same.

SPLIT SPROCKETS AND IDLERS



**SPROCKETS
AND IDLERS FOR STEEL
MINI HINGE CHAINS**

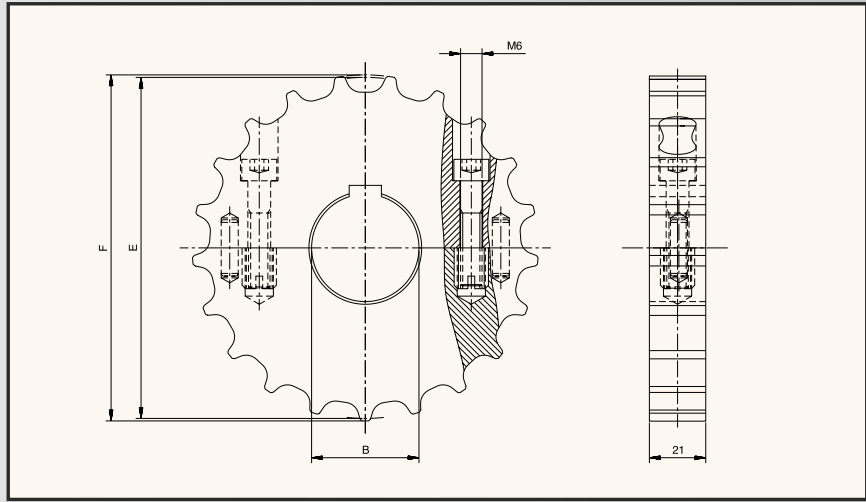

MATERIAL
page 159

page 5

Sprocket type	Code nr.	Nr. of teeth	Bore		Pitch diameter E mm	Outside diameter F mm	Hub width A mm	Weight ≈ kg
			B mm	inch				
SPLIT SPROCKETS (METRIC BORES AND KEYWAYS)								
SS MINI 21-25	753.67.61	21	25	–	129.3	128.9	21	0.30
SS MINI 21-30	753.67.62	21	30	–	129.3	128.9	21	0.30
SS MINI 21-35	753.67.63	21	35	–	129.3	128.9	21	0.30
SS MINI 21-40	753.67.64	21	40	–	129.3	128.9	21	0.30
SS MINI 21-50	753.67.65	21	50	–	129.3	128.9	21	0.30
SS MINI 25-25	753.67.81	25	25	–	153.2	153.8	21	0.40
SS MINI 25-30	753.67.82	25	30	–	153.2	153.8	21	0.40
SS MINI 25-35	753.67.83	25	35	–	153.2	153.8	21	0.40
SS MINI 25-40	753.67.84	25	40	–	153.2	153.8	21	0.40
SS MINI 25-50	753.67.85	25	50	–	153.2	153.8	21	0.40
SPLIT IDLERS (METRIC BORES WITHOUT KEYWAYS)								
SI MINI 21-25	753.67.11	21	25	–	129.3	128.9	21	0.30
SI MINI 21-30	753.67.12	21	30	–	129.3	128.9	21	0.30
SI MINI 21-35	753.67.13	21	35	–	129.3	128.9	21	0.30
SI MINI 21-40	753.67.14	21	40	–	129.3	128.9	21	0.30
SI MINI 21-50	753.67.15	21	50	–	129.3	128.9	21	0.30
SI MINI 25-25	753.67.31	25	25	–	153.2	153.8	21	0.40
SI MINI 25-30	753.67.32	25	30	–	153.2	153.8	21	0.40
SI MINI 25-35	753.67.33	25	35	–	153.2	153.8	21	0.40
SI MINI 25-40	753.67.34	25	40	–	153.2	153.8	21	0.40
SI MINI 25-50	753.67.35	25	50	–	153.2	153.8	21	0.40

Colour black or white, depending on availability.

SPLIT SPROCKETS AND IDLERS



**SPROCKETS
FOR STEEL SINGLE HINGE AND
MAGNETFLEX® CHAINS**

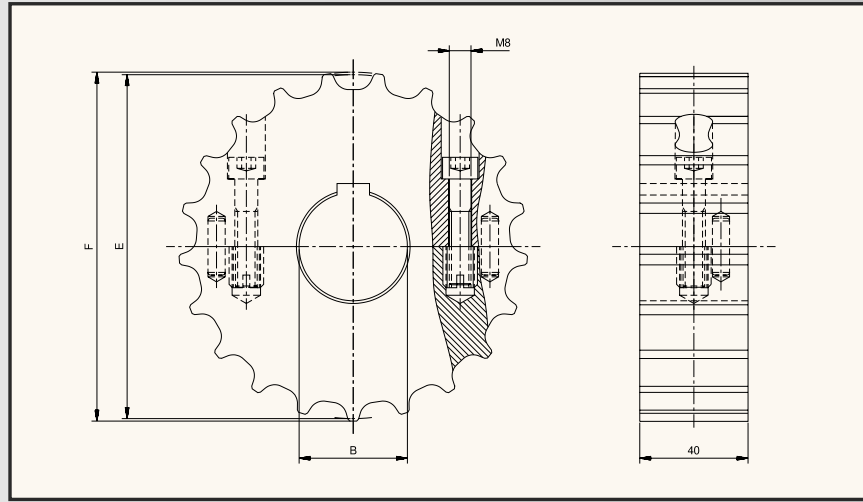

MATERIAL

page 159



3, 6, 9, 11

Sprocket type	Code nr.	Nr. of teeth	Bore		Pitch diameter E	Outside diameter F	Hub width A	Weight ≈ kg
			B					
			mm	inch	mm	mm	mm	mm
SPLIT SPROCKETS (METRIC BORES AND KEYWAYS)								
SS SSHMF 17-25	753.62.11	17	25	–	105.5	105.0	40	0.35
SS SSHMF 17-30	753.62.21	17	30	–	105.5	105.0	40	0.35
SS SSHMF 17-35	753.62.31	17	35	–	105.5	105.0	40	0.35
SS SSHMF 17-40	753.62.41	17	40	–	105.5	105.0	40	0.35
SS SSHMF 19-25	753.62.12	19	25	–	117.3	117.0	40	0.45
SS SSHMF 19-30	753.62.22	19	30	–	117.3	117.0	40	0.45
SS SSHMF 19-35	753.62.32	19	35	–	117.3	117.0	40	0.45
SS SSHMF 19-40	753.62.42	19	40	–	117.3	117.0	40	0.45
SS SSHMF 19-50	753.62.62	19	50	–	117.3	117.0	40	0.45
SS SSHMF 21-25	753.62.13	21	25	–	129.3	128.9	40	0.50
SS SSHMF 21-30	753.62.23	21	30	–	129.3	128.9	40	0.50
SS SSHMF 21-35	753.62.33	21	35	–	129.3	128.9	40	0.50
SS SSHMF 21-40	753.62.43	21	40	–	129.3	128.9	40	0.50
SS SSHMF 21-50	753.62.63	21	50	–	129.3	128.9	40	0.50
SS SSHMF 23-25	753.62.14	23	25	–	141.2	142.0	40	0.60
SS SSHMF 23-30	753.62.24	23	30	–	141.2	142.0	40	0.60
SS SSHMF 23-35	753.62.34	23	35	–	141.2	142.0	40	0.60
SS SSHMF 23-40	753.62.44	23	40	–	141.2	142.0	40	0.60
SS SSHMF 23-50	753.62.64	23	50	–	141.2	142.0	40	0.60
SS SSHMF 25-25	753.62.15	25	25	–	153.2	153.8	40	0.65
SS SSHMF 25-30	753.62.25	25	30	–	153.2	153.8	40	0.65
SS SSHMF 25-35	753.62.35	25	35	–	153.2	153.8	40	0.65
SS SSHMF 25-40	753.62.45	25	40	–	153.2	153.8	40	0.65
SS SSHMF 25-50	753.62.65	25	50	–	153.2	153.8	40	0.65
SS SSHMF 27-25	753.62.16	27	25	–	165.2	166.1	40	0.75
SS SSHMF 27-30	753.62.26	27	30	–	165.2	166.1	40	0.75
SS SSHMF 27-35	753.62.36	27	35	–	165.2	166.1	40	0.75
SS SSHMF 27-40	753.62.46	27	40	–	165.2	166.1	40	0.75
SS SSHMF 27-50	753.62.66	27	50	–	165.2	166.1	40	0.75
SPLIT SPROCKETS (INCH BORES AND KEYWAYS)								
SS SSHMF 21-1	753.66.12	21	–	1.000	129.3	128.9	40	0.50
SS SSHMF 21-1 ³ / ₁₆	753.66.22	21	–	1.188	129.3	128.9	40	0.50
SS SSHMF 21-1 ¹ / ₄	753.66.32	21	–	1.250	129.3	128.9	40	0.50
SS SSHMF 21-1 ⁷ / ₁₆	753.66.42	21	–	1.438	129.3	128.9	40	0.50
SS SSHMF 21-1 ¹ / ₂	753.66.52	21	–	1.500	129.3	128.9	40	0.50
SS SSHMF 25-1	753.66.15	25	–	1.000	153.2	153.8	40	0.65
SS SSHMF 25-1 ³ / ₁₆	753.66.25	25	–	1.188	153.2	153.8	40	0.65
SS SSHMF 25-1 ¹ / ₄	753.66.35	25	–	1.250	153.2	153.8	40	0.65
SS SSHMF 25-1 ⁷ / ₁₆	753.66.45	25	–	1.438	153.2	153.8	40	0.65
SS SSHMF 25-1 ¹ / ₂	753.66.55	25	–	1.500	153.2	153.8	40	0.65

SPLIT SPROCKETS AND IDLERS

IDLERS FOR STEEL SINGLE HINGE AND MAGNETFLEX® CHAINS

Sprocket type	Code nr.	Nr. of teeth	Bore		Pitch diameter E	Outside diameter F	Hub width A	Weight ≈ kg
			B					
			mm	inch	mm	mm	mm	mm
SPLIT IDLERS (METRIC BORES WITHOUT KEYWAYS)								
SI SSHMF 17-25	753.61.11	17	25	–	105.5	105.0	40	0.35
SI SSHMF 17-30	753.61.21	17	30	–	105.5	105.0	40	0.35
SI SSHMF 17-35	753.61.31	17	35	–	105.5	105.0	40	0.35
SI SSHMF 17-40	753.61.41	17	40	–	105.5	105.0	40	0.35
SI SSHMF 19-25	753.61.12	19	25	–	117.3	117.0	40	0.45
SI SSHMF 19-30	753.61.22	19	30	–	117.3	117.0	40	0.45
SI SSHMF 19-35	753.61.32	19	35	–	117.3	117.0	40	0.45
SI SSHMF 19-40	753.61.42	19	40	–	117.3	117.0	40	0.45
SI SSHMF 19-50	753.61.62	19	50	–	117.3	117.0	40	0.45
SI SSHMF 21-25	753.61.13	21	25	–	129.3	128.9	40	0.50
SI SSHMF 21-30	753.61.23	21	30	–	129.3	128.9	40	0.50
SI SSHMF 21-35	753.61.33	21	35	–	129.3	128.9	40	0.50
SI SSHMF 21-40	753.61.43	21	40	–	129.3	128.9	40	0.50
SI SSHMF 21-50	753.61.63	21	50	–	129.3	128.9	40	0.50
SI SSHMF 23-25	753.61.14	23	25	–	141.2	142.0	40	0.60
SI SSHMF 23-30	753.61.24	23	30	–	141.2	142.0	40	0.60
SI SSHMF 23-35	753.61.34	23	35	–	141.2	142.0	40	0.60
SI SSHMF 23-40	753.61.44	23	40	–	141.2	142.0	40	0.60
SI SSHMF 23-50	753.61.64	23	50	–	141.2	142.0	40	0.60
SI SSHMF 25-25	753.61.15	25	25	–	153.2	153.8	40	0.65
SI SSHMF 25-30	753.61.25	25	30	–	153.2	153.8	40	0.65
SI SSHMF 25-35	753.61.35	25	35	–	153.2	153.8	40	0.65
SI SSHMF 25-40	753.61.45	25	40	–	153.2	153.8	40	0.65
SI SSHMF 25-50	753.61.65	25	50	–	153.2	153.8	40	0.65
SI SSHMF 27-25	753.61.16	27	25	–	165.2	166.1	40	0.75
SI SSHMF 27-30	753.61.26	27	30	–	165.2	166.1	40	0.75
SI SSHMF 27-35	753.61.36	27	35	–	165.2	166.1	40	0.75
SI SSHMF 27-40	753.61.46	27	40	–	165.2	166.1	40	0.75
SI SSHMF 27-50	753.61.66	27	50	–	165.2	166.1	40	0.75
SPLIT IDLERS (INCH BORES WITHOUT KEYWAYS)								
SI SSHMF 21-1	753.65.12	21	–	1.000	129.3	128.9	40	0.50
SI SSHMF 21-1 ³ / ₁₆	753.65.22	21	–	1.188	129.3	128.9	40	0.50
SI SSHMF 21-1 ¹ / ₄	753.65.32	21	–	1.250	129.3	128.9	40	0.50
SI SSHMF 21-1 ⁷ / ₁₆	753.65.42	21	–	1.438	129.3	128.9	40	0.50
SI SSHMF 21-1 ¹ / ₂	753.65.52	21	–	1.500	129.3	128.9	40	0.50
SI SSHMF 25-1	753.65.15	25	–	1.000	153.2	153.8	40	0.65
SI SSHMF 25-1 ³ / ₁₆	753.65.25	25	–	1.188	153.2	153.8	40	0.65
SI SSHMF 25-1 ¹ / ₄	753.65.35	25	–	1.250	153.2	153.8	40	0.65
SI SSHMF 25-1 ⁷ / ₁₆	753.65.45	25	–	1.438	153.2	153.8	40	0.65
SI SSHMF 25-1 ¹ / ₂	753.65.55	25	–	1.500	153.2	153.8	40	0.65

Also idler drums can be used. Please refer to the table on next page.

SPLIT SPROCKETS AND IDLERS



IDLER DRUMS FOR STEEL AND PLASTIC SINGLE HINGE AND MAGNETFLEX® CHAINS

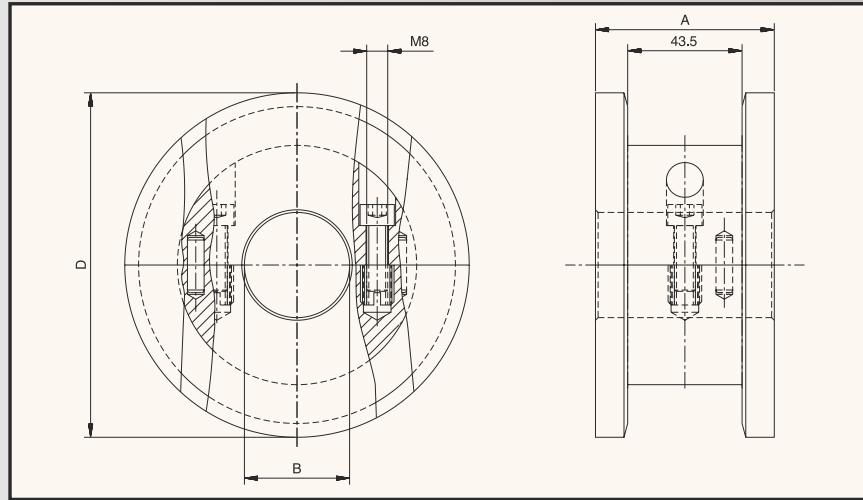

Sprocket type	Code nr.	Corresponding nr. of teeth	Bore		Pitch diameter E	Outside diameter D	Hub width A	Weight
			B					
			mm	inch	mm	mm	mm	≈ kg
METRIC BORES								
SD SHMF 131-25	754.10.02	21	25	–	–	131	68	0.70
SD SHMF 131-30	754.10.03	21	30	–	–	131	68	0.70
SD SHMF 131-35	754.10.04	21	35	–	–	131	68	0.70
SD SHMF 131-40	754.10.05	21	40	–	–	131	68	0.70
SD SHMF 131-50	754.10.06	21	50	–	–	131	68	0.70
SD SHMF 143-25	754.11.22	23	25	–	–	143	68	0.85
SD SHMF 143-30	754.11.23	23	30	–	–	143	68	0.85
SD SHMF 143-35	754.11.24	23	35	–	–	143	68	0.85
SD SHMF 143-40	754.11.25	23	40	–	–	143	68	0.85
SD SHMF 143-50	754.11.26	23	50	–	–	143	68	0.85
SD SHMF 155-25	754.12.42	25	25	–	–	155	68	0.95
SD SHMF 155-30	754.12.43	25	30	–	–	155	68	0.95
SD SHMF 155-35	754.12.44	25	35	–	–	155	68	0.95
SD SHMF 155-40	754.12.45	25	40	–	–	155	68	0.95
SD SHMF 155-50	754.12.46	25	50	–	–	155	68	0.95
INCH BORES								
SD SHMF 131-1	754.10.07	21	–	1.000	–	131	68	0.70
SD SHMF 131-1 ³ / ₁₆	754.10.08	21	–	1.188	–	131	68	0.70
SD SHMF 131-1 ¹ / ₄	754.10.09	21	–	1.250	–	131	68	0.70
SD SHMF 131-1 ⁷ / ₁₆	754.10.10	21	–	1.438	–	131	68	0.70
SD SHMF 131-1 ¹ / ₂	754.10.11	21	–	1.500	–	131	68	0.70
SD SHMF 143-1	754.11.27	23	–	1.000	–	143	68	0.85
SD SHMF 143-1 ³ / ₁₆	754.11.28	23	–	1.188	–	143	68	0.85
SD SHMF 143-1 ¹ / ₄	754.11.29	23	–	1.250	–	143	68	0.85
SD SHMF 143-1 ⁷ / ₁₆	754.11.30	23	–	1.438	–	143	68	0.85
SD SHMF 143-1 ¹ / ₂	754.11.31	23	–	1.500	–	143	68	0.85
SD SHMF 155-1	754.12.47	25	–	1.000	–	155	68	0.95
SD SHMF 155-1 ³ / ₁₆	754.12.48	25	–	1.188	–	155	68	0.95
SD SHMF 155-1 ¹ / ₄	754.12.49	25	–	1.250	–	155	68	0.95
SD SHMF 155-1 ⁷ / ₁₆	754.12.50	25	–	1.438	–	155	68	0.95
SD SHMF 155-1 ¹ / ₂	754.12.51	25	–	1.500	–	155	68	0.95

Colour black or white, depending on availability.

SPLIT SPROCKETS AND IDLERS

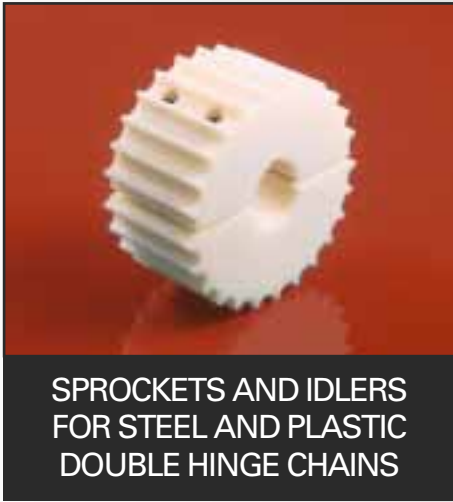

**SPROCKETS AND IDLERS
FOR STEEL AND PLASTIC
DOUBLE HINGE CHAINS**

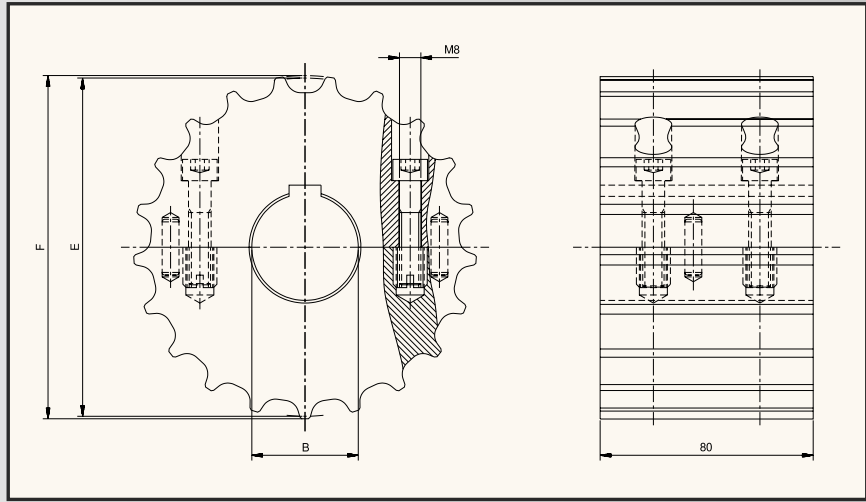

Sprocket type	Code nr.	Nr. of teeth	Bore		Pitch diameter E	Outside diameter F	Hub width A	Weight ≈ kg
			B	inch				
SPLIT SPROCKETS (METRIC BORES AND KEYWAYS)								
SS DBH 21-25	753.64.61	21	25	–	129.3	128.9	80	1.0
SS DBH 21-30	753.64.62	21	30	–	129.3	128.9	80	1.0
SS DBH 21-35	753.64.63	21	35	–	129.3	128.9	80	1.0
SS DBH 21-40	753.64.64	21	40	–	129.3	128.9	80	1.0
SS DBH 21-50	753.64.65	21	50	–	129.3	128.9	80	1.0
SS DBH 25-25	753.64.81	25	25	–	153.2	153.8	80	1.3
SS DBH 25-30	753.64.82	25	30	–	153.2	153.8	80	1.3
SS DBH 25-35	753.64.83	25	35	–	153.2	153.8	80	1.3
SS DBH 25-40	753.64.84	25	40	–	153.2	153.8	80	1.3
SS DBH 25-50	753.64.85	25	50	–	153.2	153.8	80	1.3
SPLIT IDLERS (METRIC BORES WITHOUT KEYWAYS)								
SI DBH 21-25	753.64.11	21	25	–	129.3	128.9	80	1.0
SI DBH 21-30	753.64.12	21	30	–	129.3	128.9	80	1.0
SI DBH 21-35	753.64.13	21	35	–	129.3	128.9	80	1.0
SI DBH 21-40	753.64.14	21	40	–	129.3	128.9	80	1.0
SI DBH 21-50	753.64.15	21	50	–	129.3	128.9	80	1.0
SI DBH 25-25	753.64.31	25	25	–	153.2	153.8	80	1.3
SI DBH 25-30	753.64.32	25	30	–	153.2	153.8	80	1.3
SI DBH 25-35	753.64.33	25	35	–	153.2	153.8	80	1.3
SI DBH 25-40	753.64.34	25	40	–	153.2	153.8	80	1.3
SI DBH 25-50	753.64.35	25	50	–	153.2	153.8	80	1.3

Colour black or white, depending on availability.

Also idler drums can be used. Please refer to the tables on pages 116 and 117.

SPLIT SPROCKETS AND IDLERS



**IDLER DRUMS
FOR STEEL DOUBLE HINGE
CHAINS**

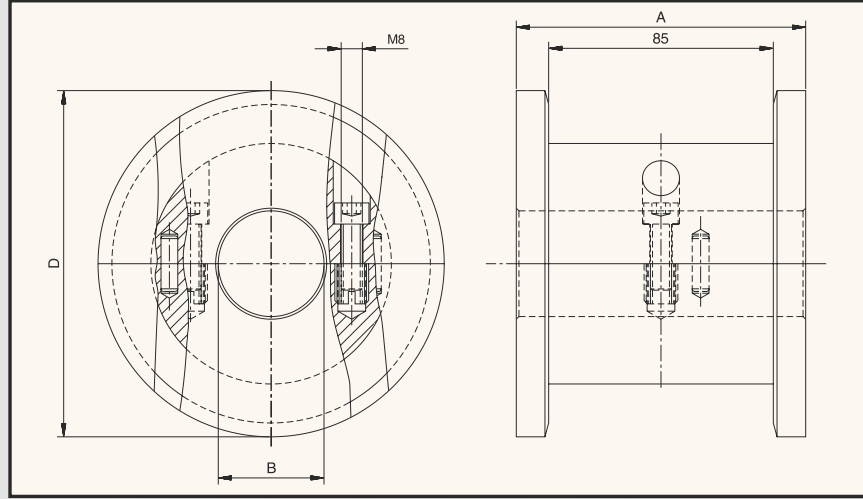

MATERIAL

page 159



page 4, 10

Sprocket type	Code nr.	Corresponding nr. of teeth	Bore		Pitch diameter E	Outside diameter D	Hub width A	Weight ≈ kg
			B					
			mm	inch	mm	mm	mm	
METRIC BORES								
SD 77 131-25	754.10.92	21	25	–	–	131	109.5	1.1
SD 77 131-30	754.10.93	21	30	–	–	131	109.5	1.1
SD 77 131-35	754.10.94	21	35	–	–	131	109.5	1.1
SD 77 131-40	754.10.95	21	40	–	–	131	109.5	1.1
SD 77 131-50	754.10.96	21	50	–	–	131	109.5	1.1
SD 77 143-25	754.12.12	23	25	–	–	143	109.5	1.3
SD 77 143-30	754.12.13	23	30	–	–	143	109.5	1.3
SD 77 143-35	754.12.14	23	35	–	–	143	109.5	1.3
SD 77 143-40	754.12.15	23	40	–	–	143	109.5	1.3
SD 77 143-50	754.12.16	23	50	–	–	143	109.5	1.3
SD 77 155-25	754.13.32	25	25	–	–	155	109.5	1.5
SD 77 155-30	754.13.33	25	30	–	–	155	109.5	1.5
SD 77 155-35	754.13.34	25	35	–	–	155	109.5	1.5
SD 77 155-40	754.13.35	25	40	–	–	155	109.5	1.5
SD 77 155-50	754.13.36	25	50	–	–	155	109.5	1.5

SPLIT SPROCKETS AND IDLERS

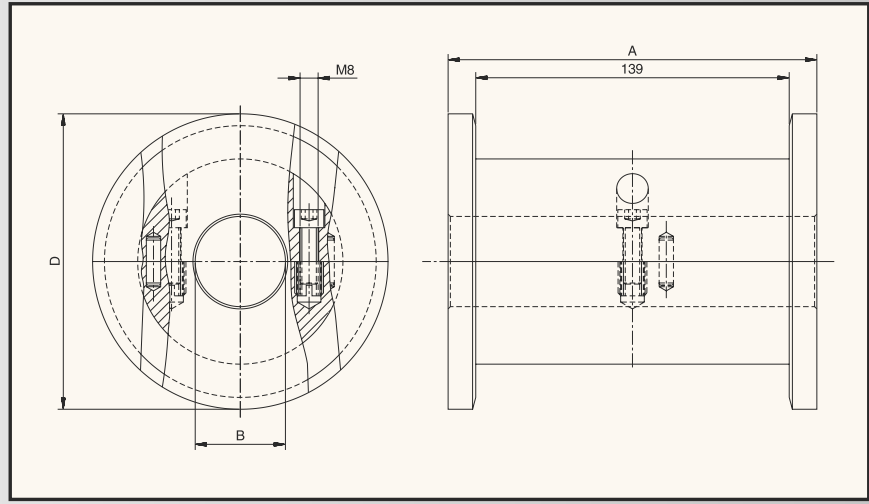

MATERIAL
page 159

page 14, 21, 27

Sprocket type	Code nr.	Corresponding nr. of teeth	Bore		Pitch diameter E	Outside diameter D	Hub width A	Weight ≈ kg
			mm	inch				
METRIC BORES								
SD SWH 131-25	754.11.07	21	25	–	–	131	163.5	1.4
SD SWH 131-30	754.11.08	21	30	–	–	131	163.5	1.4
SD SWH 131-35	754.11.09	21	35	–	–	131	163.5	1.4
SD SWH 131-40	754.11.10	21	40	–	–	131	163.5	1.4
SD SWH 131-50	754.11.11	21	50	–	–	131	163.5	1.4
SD SWH 143-25	754.12.27	23	25	–	–	143	163.5	1.7
SD SWH 143-30	754.12.28	23	30	–	–	143	163.5	1.7
SD SWH 143-35	754.12.29	23	35	–	–	143	163.5	1.7
SD SWH 143-40	754.12.30	23	40	–	–	143	163.5	1.7
SD SWH 143-50	754.12.31	23	50	–	–	143	163.5	1.7
SD SWH 155-25	754.13.47	25	25	–	–	155	163.5	2.0
SD SWH 155-30	754.13.48	25	30	–	–	155	163.5	2.0
SD SWH 155-35	754.13.49	25	35	–	–	155	163.5	2.0
SD SWH 155-40	754.13.50	25	40	–	–	155	163.5	2.0
SD SWH 155-50	754.13.51	25	50	–	–	155	163.5	2.0

SPLIT SPROCKETS AND IDLERS



SPROCKETS AND IDLERS FOR STEEL HEAVY DUTY CHAINS

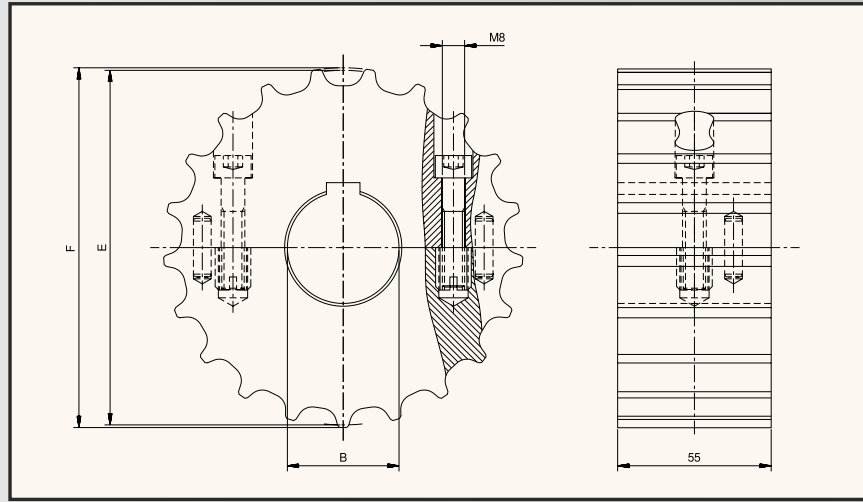

MATERIAL

page 159



Sprocket type	Code nr.	Nr. of teeth	Bore		Pitch diameter E	Outside diameter F	Hub width A	Weight ≈ kg
			B	mm				
SPLIT SPROCKETS (METRIC BORES AND KEYWAYS)								
SS 75 21-25	753.63.61	21	25	–	129.3	128.9	55	0.70
SS 75 21-30	753.63.62	21	30	–	129.3	128.9	55	0.70
SS 75 21-35	753.63.63	21	35	–	129.3	128.9	55	0.70
SS 75 21-40	753.63.64	21	40	–	129.3	128.9	55	0.70
SS 75 21-50	753.63.65	21	50	–	129.3	128.9	55	0.70
SS 75 25-25	753.63.81	25	25	–	153.2	153.8	55	0.90
SS 75 25-30	753.63.82	25	30	–	153.2	153.8	55	0.90
SS 75 25-35	753.63.83	25	35	–	153.2	153.8	55	0.90
SS 75 25-40	753.63.84	25	40	–	153.2	153.8	55	0.90
SS 75 25-50	753.63.85	25	50	–	153.2	153.8	55	0.90
SPLIT IDLERS (METRIC BORES WITHOUT KEYWAYS)								
SI 75 21-25	753.63.11	21	25	–	129.3	128.9	55	0.70
SI 75 21-30	753.63.12	21	30	–	129.3	128.9	55	0.70
SI 75 21-35	753.63.13	21	35	–	129.3	128.9	55	0.70
SI 75 21-40	753.63.14	21	40	–	129.3	128.9	55	0.70
SI 75 21-50	753.63.15	21	50	–	129.3	128.9	55	0.70
SI 75 25-25	753.63.31	25	25	–	153.2	153.8	55	0.90
SI 75 25-30	753.63.32	25	30	–	153.2	153.8	55	0.90
SI 75 25-35	753.63.33	25	35	–	153.2	153.8	55	0.90
SI 75 25-40	753.63.34	25	40	–	153.2	153.8	55	0.90
SI 75 25-50	753.63.35	25	50	–	153.2	153.8	55	0.90

Colour black or white, depending on availability.

Also idler drums can be used. Please refer to the table on page 119.

SPLIT SPROCKETS AND IDLERS



IDLER DRUMS FOR STEEL AND PLASTIC STRAIGHT RUN AND MAGNETFLEX® HEAVY DUTY CHAINS

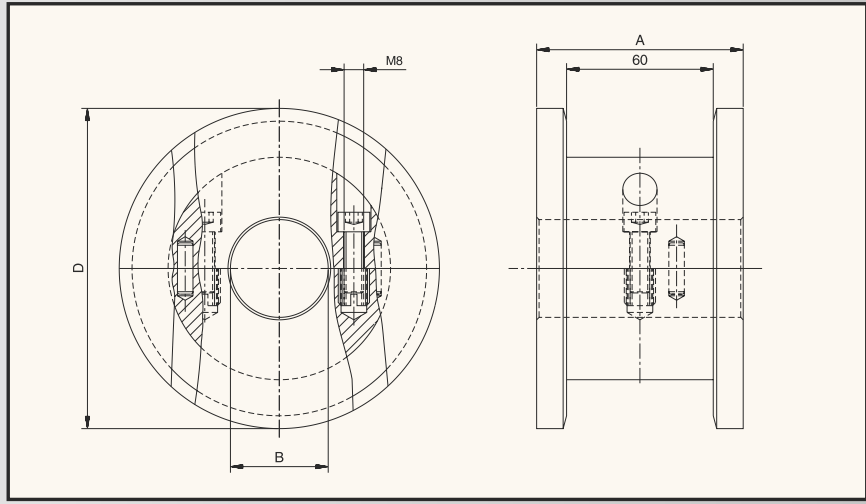

14, 18, 22,
24, 28, 29



page 159



page 4, 6, 9, 11

Sprocket type	Code nr.	Corresponding nr. of teeth	Bore		Pitch diameter E	Outside diameter D	Hub width A	Weight ≈
			mm	inch				
METRIC BORES								
SD 75 131-25	754.10.47	21	25	–	–	131	84.5	0.80
SD 75 131-30	754.10.48	21	30	–	–	131	84.5	0.80
SD 75 131-35	754.10.49	21	35	–	–	131	84.5	0.80
SD 75 131-40	754.10.50	21	40	–	–	131	84.5	0.80
SD 75 131-50	754.10.51	21	50	–	–	131	84.5	0.80
SD 75 143-25	754.11.67	23	25	–	–	143	84.5	0.95
SD 75 143-30	754.11.68	23	30	–	–	143	84.5	0.95
SD 75 143-35	754.11.69	23	35	–	–	143	84.5	0.95
SD 75 143-40	754.11.70	23	40	–	–	143	84.5	0.95
SD 75 143-50	754.11.71	23	50	–	–	143	84.5	0.95
SD 75 155-25	754.12.87	25	25	–	–	155	84.5	1.10
SD 75 155-30	754.12.88	25	30	–	–	155	84.5	1.10
SD 75 155-35	754.12.89	25	35	–	–	155	84.5	1.10
SD 75 155-40	754.12.90	25	40	–	–	155	84.5	1.10
SD 75 155-50	754.12.91	25	50	–	–	155	84.5	1.10

SPLIT SPROCKETS AND IDLERS



**SPROCKETS FOR PLASTIC
SINGLE HINGE
CHAINS**

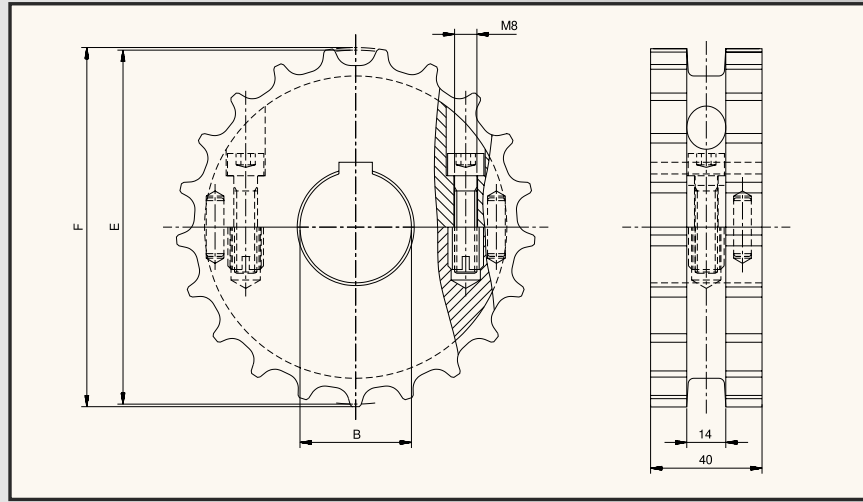

MATERIAL

page 159



page 13, 21

Sprocket type	Code nr.	Nr. of teeth	Bore		Pitch diameter E	Outside diameter F	Hub width A	Weight ≈ kg
			B	mm				
SPLIT SPROCKETS (METRIC BORES AND KEYWAYS)								
SS SH 17-25	754.62.11	17	25	–	105.5	105.0	40	0.35
SS SH 17-30	754.62.21	17	30	–	105.5	105.0	40	0.35
SS SH 17-35	754.62.31	17	35	–	105.5	105.0	40	0.35
SS SH 17-40	754.62.41	17	40	–	105.5	105.0	40	0.35
SS SH 19-25	754.62.12	19	25	–	117.3	117.0	40	0.45
SS SH 19-30	754.62.22	19	30	–	117.3	117.0	40	0.45
SS SH 19-35	754.62.32	19	35	–	117.3	117.0	40	0.45
SS SH 19-40	754.62.42	19	40	–	117.3	117.0	40	0.45
SS SH 19-50	754.62.62	19	50	–	117.3	117.0	40	0.45
SS SH 21-25	754.62.13	21	25	–	129.3	128.9	40	0.50
SS SH 21-30	754.62.23	21	30	–	129.3	128.9	40	0.50
SS SH 21-35	754.62.33	21	35	–	129.3	128.9	40	0.50
SS SH 21-40	754.62.43	21	40	–	129.3	128.9	40	0.50
SS SH 21-50	754.62.63	21	50	–	129.3	128.9	40	0.50
SS SH 23-25	754.62.14	23	25	–	141.2	142.0	40	0.60
SS SH 23-30	754.62.24	23	30	–	141.2	142.0	40	0.60
SS SH 23-35	754.62.34	23	35	–	141.2	142.0	40	0.60
SS SH 23-40	754.62.44	23	40	–	141.2	142.0	40	0.60
SS SH 23-50	754.62.64	23	50	–	141.2	142.0	40	0.60
SS SH 25-25	754.62.15	25	25	–	153.2	153.8	40	0.65
SS SH 25-30	754.62.25	25	30	–	153.2	153.8	40	0.65
SS SH 25-35	754.62.35	25	35	–	153.2	153.8	40	0.65
SS SH 25-40	754.62.45	25	40	–	153.2	153.8	40	0.65
SS SH 25-50	754.62.65	25	50	–	153.2	153.8	40	0.65
SS SH 27-25	754.62.16	27	25	–	165.2	166.1	40	0.75
SS SH 27-30	754.62.26	27	30	–	165.2	166.1	40	0.75
SS SH 27-35	754.62.36	27	35	–	165.2	166.1	40	0.75
SS SH 27-40	754.62.46	27	40	–	165.2	166.1	40	0.75
SS SH 27-50	754.62.66	27	50	–	165.2	166.1	40	0.75
SPLIT SPROCKETS (INCH BORES AND KEYWAYS)								
SS SH 21-1	754.66.12	21	–	1.000	129.3	128.9	40	0.50
SS SH 21-1 ³ / ₁₆	754.66.22	21	–	1.188	129.3	128.9	40	0.50
SS SH 21-1 ¹ / ₄	754.66.32	21	–	1.250	129.3	128.9	40	0.50
SS SH 21-1 ⁷ / ₁₆	754.66.42	21	–	1.438	129.3	128.9	40	0.50
SS SH 21-1 ¹ / ₂	754.66.52	21	–	1.500	129.3	128.9	40	0.50
SS SH 25-1	754.66.15	25	–	1.000	153.2	153.8	40	0.65
SS SH 25-1 ³ / ₁₆	754.66.25	25	–	1.188	153.2	153.8	40	0.65
SS SH 25-1 ¹ / ₄	754.66.35	25	–	1.250	153.2	153.8	40	0.65
SS SH 25-1 ⁷ / ₁₆	754.66.45	25	–	1.438	153.2	153.8	40	0.65
SS SH 25-1 ¹ / ₂	754.66.55	25	–	1.500	153.2	153.8	40	0.65

SPLIT SPROCKETS AND IDLERS

IDLERS FOR PLASTIC SINGLE HINGE CHAINS

Sprocket type	Code nr.	Nr. of teeth	Bore		Pitch diameter E	Outside diameter F	Hub width A	Weight ≈ kg
			B					
			mm	inch	mm	mm	mm	mm
SPLIT IDLERS (METRIC BORES WITHOUT KEYWAYS)								
SI SH 17-25	754.61.11	17	25	–	105.5	105.0	40	0.35
SI SH 17-30	754.61.21	17	30	–	105.5	105.0	40	0.35
SI SH 17-35	754.61.31	17	35	–	105.5	105.0	40	0.35
SI SH 17-40	754.61.41	17	40	–	105.5	105.0	40	0.35
SI SH 19-25	754.61.12	19	25	–	117.3	117.0	40	0.45
SI SH 19-30	754.61.22	19	30	–	117.3	117.0	40	0.45
SI SH 19-35	754.61.32	19	35	–	117.3	117.0	40	0.45
SI SH 19-40	754.61.42	19	40	–	117.3	117.0	40	0.45
SI SH 19-50	754.61.62	19	50	–	117.3	117.0	40	0.45
SI SH 21-25	754.61.13	21	25	–	129.3	128.9	40	0.50
SI SH 21-30	754.61.23	21	30	–	129.3	128.9	40	0.50
SI SH 21-35	754.61.33	21	35	–	129.3	128.9	40	0.50
SI SH 21-40	754.61.43	21	40	–	129.3	128.9	40	0.50
SI SH 21-50	754.61.63	21	50	–	129.3	128.9	40	0.50
SI SH 23-25	754.61.14	23	25	–	141.2	142.0	40	0.60
SI SH 23-30	754.61.24	23	30	–	141.2	142.0	40	0.60
SI SH 23-35	754.61.34	23	35	–	141.2	142.0	40	0.60
SI SH 23-40	754.61.44	23	40	–	141.2	142.0	40	0.60
SI SH 23-50	754.61.64	23	50	–	141.2	142.0	40	0.60
SI SH 25-25	754.61.15	25	25	–	153.2	153.8	40	0.65
SI SH 25-30	754.61.25	25	30	–	153.2	153.8	40	0.65
SI SH 25-35	754.61.35	25	35	–	153.2	153.8	40	0.65
SI SH 25-40	754.61.45	25	40	–	153.2	153.8	40	0.65
SI SH 25-50	754.61.65	25	50	–	153.2	153.8	40	0.65
SI SH 27-25	754.61.16	27	25	–	165.2	166.1	40	0.75
SI SH 27-30	754.61.26	27	30	–	165.2	166.1	40	0.75
SI SH 27-35	754.61.36	27	35	–	165.2	166.1	40	0.75
SI SH 27-40	754.61.46	27	40	–	165.2	166.1	40	0.75
SI SH 27-50	754.61.66	27	50	–	165.2	166.1	40	0.75
SPLIT IDLERS (INCH BORES WITHOUT KEYWAYS)								
SI SH 21-1	754.65.12	21	–	1.000	129.3	128.9	40	0.50
SI SH 21-1 ³ / ₁₆	754.65.22	21	–	1.188	129.3	128.9	40	0.50
SI SH 21-1 ¹ / ₄	754.65.32	21	–	1.250	129.3	128.9	40	0.50
SI SH 21-1 ⁷ / ₁₆	754.65.42	21	–	1.438	129.3	128.9	40	0.50
SI SH 21-1 ¹ / ₂	754.65.52	21	–	1.500	129.3	128.9	40	0.50
SI SH 25-1	754.65.15	25	–	1.000	153.2	153.8	40	0.65
SI SH 25-1 ³ / ₁₆	754.65.25	25	–	1.188	153.2	153.8	40	0.65
SI SH 25-1 ¹ / ₄	754.65.35	25	–	1.250	153.2	153.8	40	0.65
SI SH 25-1 ⁷ / ₁₆	754.65.45	25	–	1.438	153.2	153.8	40	0.65
SI SH 25-1 ¹ / ₂	754.65.55	25	–	1.500	153.2	153.8	40	0.65

Also idler drums can be used. Please refer to the table on page 114.

SPLIT SPROCKETS AND IDLERS



**SPROCKETS
FOR PLASTIC RADIUS HINGE
AND MAGNETFLEX® CHAINS**

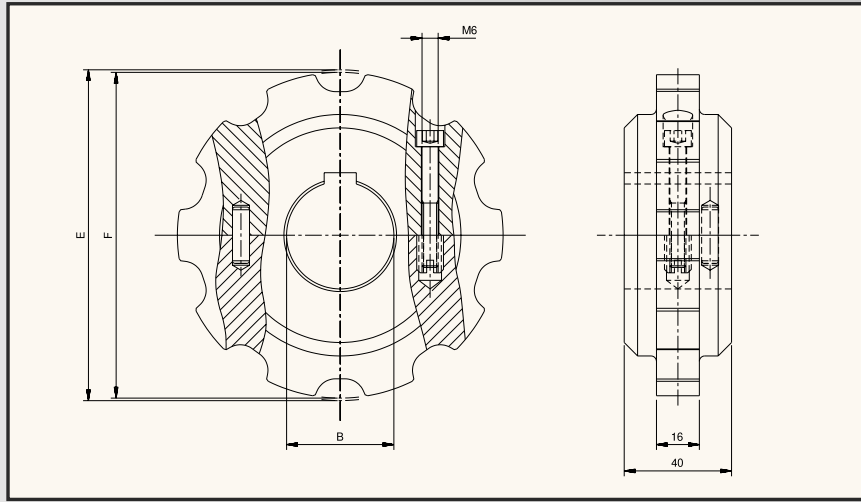

MATERIAL

page 159



page 15-17, 23

Sprocket type	Code nr.	Nr. of teeth	Bore		Pitch diameter E	Outside diameter F	Hub width A	Weight ≈ kg
			B	mm				
SPLIT SPROCKETS (METRIC BORES AND KEYWAYS)								
SS RH 9-25	754.60.51	9	25	–	111.4	109.0	40	0.30
SS RH 9-30	754.60.52	9	30	–	111.4	109.0	40	0.30
SS RH 9-35	754.60.53	9	35	–	111.4	109.0	40	0.30
SS RH 9-40	754.60.54	9	40	–	111.4	109.0	40	0.30
SS RH 9-50	754.60.55	9	50	–	111.4	109.0	40	0.30
SS RH 10-25	754.60.61	10	25	–	123.3	121.4	40	0.35
SS RH 10-30	754.60.62	10	30	–	123.3	121.4	40	0.35
SS RH 10-35	754.60.63	10	35	–	123.3	121.4	40	0.35
SS RH 10-40	754.60.64	10	40	–	123.3	121.4	40	0.35
SS RH 10-50	754.60.65	10	50	–	123.3	121.4	40	0.35
SS RH 11-25	754.60.71	11	25	–	135.2	133.9	40	0.40
SS RH 11-30	754.60.72	11	30	–	135.2	133.9	40	0.40
SS RH 11-35	754.60.73	11	35	–	135.2	133.9	40	0.40
SS RH 11-40	754.60.74	11	40	–	135.2	133.9	40	0.40
SS RH 11-50	754.60.75	11	50	–	135.2	133.9	40	0.40
SS RH 12-25	754.60.81	12	25	–	147.2	145.8	40	0.45
SS RH 12-30	754.60.82	12	30	–	147.2	145.8	40	0.45
SS RH 12-35	754.60.83	12	35	–	147.2	145.8	40	0.45
SS RH 12-40	754.60.84	12	40	–	147.2	145.8	40	0.45
SS RH 12-50	754.60.85	12	50	–	147.2	145.8	40	0.45
SPLIT SPROCKETS (INCH BORES AND KEYWAYS)								
SS RH 10-1	754.60.66	10	–	1.000	123.3	121.4	40	0.35
SS RH 10-1 ³ / ₁₆	754.60.67	10	–	1.188	123.3	121.4	40	0.35
SS RH 10-1 ¹ / ₄	754.60.68	10	–	1.250	123.3	121.4	40	0.35
SS RH 10-1 ⁷ / ₁₆	754.60.69	10	–	1.438	123.3	121.4	40	0.35
SS RH 10-1 ¹ / ₂	754.60.70	10	–	1.500	123.3	121.4	40	0.35
SS RH 12-1	754.60.86	12	–	1.000	147.2	145.8	40	0.45
SS RH 12-1 ³ / ₁₆	754.60.87	12	–	1.188	147.2	145.8	40	0.45
SS RH 12-1 ¹ / ₄	754.60.88	12	–	1.250	147.2	145.8	40	0.45
SS RH 12-1 ⁷ / ₁₆	754.60.89	12	–	1.438	147.2	145.8	40	0.45
SS RH 12-1 ¹ / ₂	754.60.90	12	–	1.500	147.2	145.8	40	0.45

SPLIT SPROCKETS AND IDLERS

IDLERS FOR PLASTIC RADIUS HINGE AND MAGNETFLEX® CHAINS

Sprocket type	Code nr.	Nr. of teeth	Bore		Pitch diameter E	Outside diameter F	Hub width A	Weight ≈ kg
			B					
			mm	inch	mm	mm	mm	mm
SPLIT IDLERS (METRIC BORES WITHOUT KEYWAYS)								
SI RH 9-25	754.60.01	9	25	–	111.4	109.0	40	0.30
SI RH 9-30	754.60.02	9	30	–	111.4	109.0	40	0.30
SI RH 9-35	754.60.03	9	35	–	111.4	109.0	40	0.30
SI RH 9-40	754.60.04	9	40	–	111.4	109.0	40	0.30
SI RH 9-50	754.60.05	9	50	–	111.4	109.0	40	0.30
SI RH 10-25	754.60.11	10	25	–	123.3	121.4	40	0.35
SI RH 10-30	754.60.12	10	30	–	123.3	121.4	40	0.35
SI RH 10-35	754.60.13	10	35	–	123.3	121.4	40	0.35
SI RH 10-40	754.60.14	10	40	–	123.3	121.4	40	0.35
SI RH 10-50	754.60.15	10	50	–	123.3	121.4	40	0.35
SI RH 11-25	754.60.21	11	25	–	135.2	133.9	40	0.40
SI RH 11-30	754.60.22	11	30	–	135.2	133.9	40	0.40
SI RH 11-35	754.60.23	11	35	–	135.2	133.9	40	0.40
SI RH 11-40	754.60.24	11	40	–	135.2	133.9	40	0.40
SI RH 11-50	754.60.25	11	50	–	135.2	133.9	40	0.40
SI RH 12-25	754.60.31	12	25	–	147.2	145.8	40	0.45
SI RH 12-30	754.60.32	12	30	–	147.2	145.8	40	0.45
SI RH 12-35	754.60.33	12	35	–	147.2	145.8	40	0.45
SI RH 12-40	754.60.34	12	40	–	147.2	145.8	40	0.45
SI RH 12-50	754.60.35	12	50	–	147.2	145.8	40	0.45
SPLIT IDLERS (INCH BORES WITHOUT KEYWAYS)								
SI RH 10-1	754.60.16	10	–	1.000	123.3	121.4	40	0.35
SI RH 10-1 ³ / ₁₆	754.60.17	10	–	1.188	123.3	121.4	40	0.35
SI RH 10-1 ¹ / ₄	754.60.18	10	–	1.250	123.3	121.4	40	0.35
SI RH 10-1 ⁷ / ₁₆	754.60.19	10	–	1.438	123.3	121.4	40	0.35
SI RH 10-1 ¹ / ₂	754.60.20	10	–	1.500	123.3	121.4	40	0.35
SI RH 12-1	754.60.36	12	–	1.000	147.2	145.8	40	0.45
SI RH 12-1 ³ / ₁₆	754.60.37	12	–	1.188	147.2	145.8	40	0.45
SI RH 12-1 ¹ / ₄	754.60.38	12	–	1.250	147.2	145.8	40	0.45
SI RH 12-1 ⁷ / ₁₆	754.60.39	12	–	1.438	147.2	145.8	40	0.45
SI RH 12-1 ¹ / ₂	754.60.40	12	–	1.500	147.2	145.8	40	0.45

Also idler drums can be used. Please refer to the tables on pages 114, 124 and 125.

SPLIT SPROCKETS AND IDLERS



**IDLER DRUMS FOR
PLASTIC SMALL RADIUS
HINGE CHAINS**

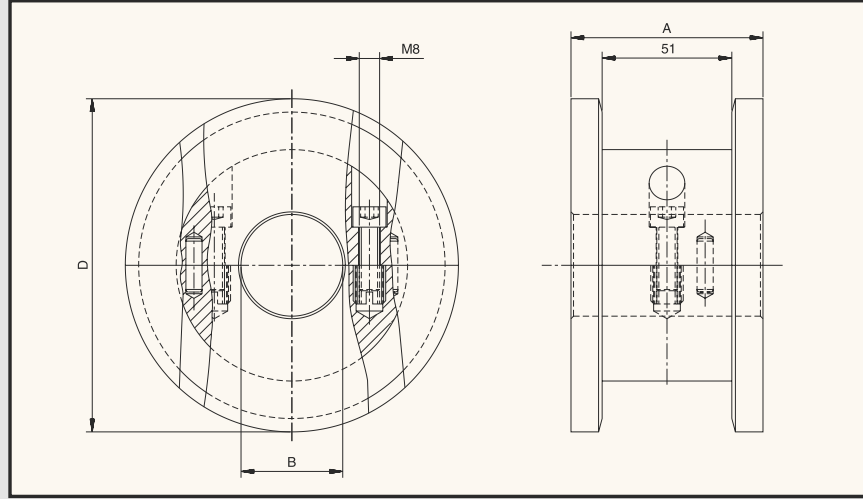

MATERIAL

page 159



page 15

Sprocket type	Code nr.	Corresponding nr. of teeth	Bore		Pitch diameter E	Outside diameter D	Hub width A	Weight ≈ kg
			mm	inch				
METRIC BORES								
SD SRH 131-25	754.10.17	10	25	–	–	131	75.5	0.75
SD SRH 131-30	754.10.18	10	30	–	–	131	75.5	0.75
SD SRH 131-35	754.10.19	10	35	–	–	131	75.5	0.75
SD SRH 131-40	754.10.20	10	40	–	–	131	75.5	0.75
SD SRH 131-50	754.10.21	10	50	–	–	131	75.5	0.75
SD SRH 143-25	754.11.37	11	25	–	–	143	75.5	0.85
SD SRH 143-30	754.11.38	11	30	–	–	143	75.5	0.85
SD SRH 143-35	754.11.39	11	35	–	–	143	75.5	0.85
SD SRH 143-40	754.11.40	11	40	–	–	143	75.5	0.85
SD SRH 143-50	754.11.41	11	50	–	–	143	75.5	0.85
SD SRH 155-25	754.12.57	12	25	–	–	155	75.5	1.00
SD SRH 155-30	754.12.58	12	30	–	–	155	75.5	1.00
SD SRH 155-35	754.12.59	12	35	–	–	155	75.5	1.00
SD SRH 155-40	754.12.60	12	40	–	–	155	75.5	1.00
SD SRH 155-50	754.12.61	12	50	–	–	155	75.5	1.00

SPLIT SPROCKETS AND IDLERS

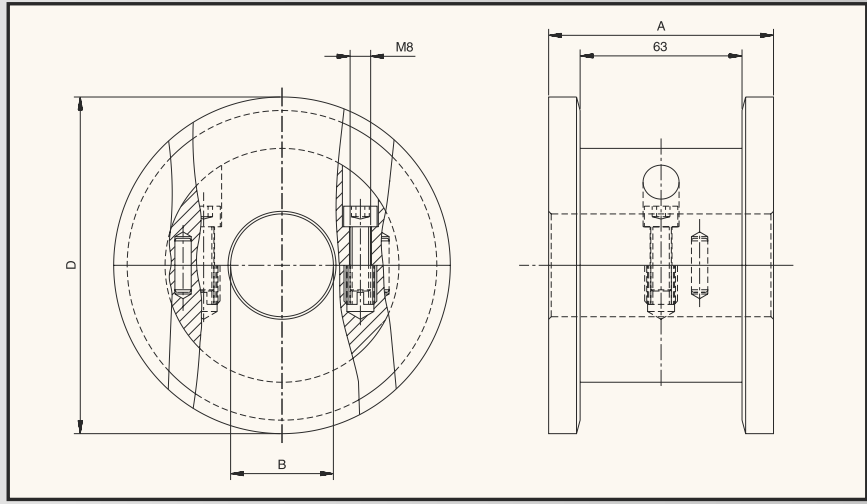

MATERIAL
page 159

page 16

Sprocket type	Code nr.	Corresponding nr. of teeth	Bore		Pitch diameter E	Outside diameter D	Hub width A	Weight ≈
			mm	inch				
METRIC BORES								
SD RH 131-25	754.10.62	10	25	–	–	131	87.5	0.85
SD RH 131-30	754.10.63	10	30	–	–	131	87.5	0.85
SD RH 131-35	754.10.64	10	35	–	–	131	87.5	0.85
SD RH 131-40	754.10.65	10	40	–	–	131	87.5	0.85
SD RH 131-50	754.10.66	10	50	–	–	131	87.5	0.85
SD RH 143-25	754.11.82	11	25	–	–	143	87.5	1.00
SD RH 143-30	754.11.83	11	30	–	–	143	87.5	1.00
SD RH 143-35	754.11.84	11	35	–	–	143	87.5	1.00
SD RH 143-40	754.11.85	11	40	–	–	143	87.5	1.00
SD RH 143-50	754.11.86	11	50	–	–	143	87.5	1.00
SD RH 155-25	754.13.02	12	25	–	–	155	87.5	1.20
SD RH 155-30	754.13.03	12	30	–	–	155	87.5	1.20
SD RH 155-35	754.13.04	12	35	–	–	155	87.5	1.20
SD RH 155-40	754.13.05	12	40	–	–	155	87.5	1.20
SD RH 155-50	754.13.06	12	50	–	–	155	87.5	1.20

SPLIT SPROCKETS AND IDLERS



SPROCKETS AND IDLERS FOR PLASTIC HEAVY DUTY CHAINS

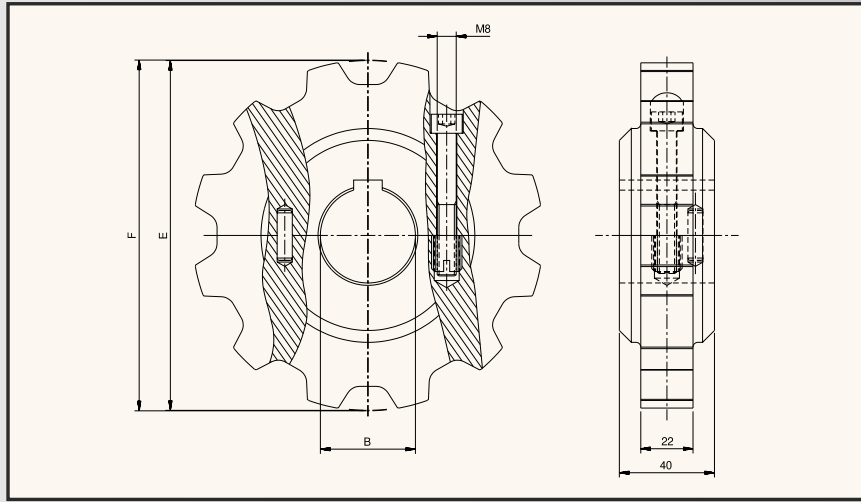

MATERIAL

page 159



14, 18, 19, 22,
24, 25, 28, 29

Sprocket type	Code nr.	Nr. of teeth	Bore		Pitch diameter E	Outside diameter F	Hub width A	Weight ≈ kg
			B					
			mm	inch				
SPLIT SPROCKETS (METRIC BORES AND KEYWAYS)								
SS HD 11-25	754.63.71	11	25	–	135.2	135.4	40	0.40
SS HD 11-30	754.63.72	11	30	–	135.2	135.4	40	0.40
SS HD 11-35	754.63.73	11	35	–	135.2	135.4	40	0.40
SS HD 11-40	754.63.74	11	40	–	135.2	135.4	40	0.40
SS HD 11-50	754.63.75	11	50	–	135.2	135.4	40	0.40
SS HD 12-25	754.63.81	12	25	–	147.2	148.6	40	0.50
SS HD 12-30	754.63.82	12	30	–	147.2	148.6	40	0.50
SS HD 12-35	754.63.83	12	35	–	147.2	148.6	40	0.50
SS HD 12-40	754.63.84	12	40	–	147.2	148.6	40	0.50
SS HD 12-50	754.63.85	12	50	–	147.2	148.6	40	0.50
SPLIT SPROCKETS (INCH BORES AND KEYWAYS)								
SS HD 11-1	754.63.76	11	–	1.000	135.2	135.4	40	0.40
SS HD 11-1 ³ / ₁₆	754.63.77	11	–	1.188	135.2	135.4	40	0.40
SS HD 11-1 ¹ / ₄	754.63.78	11	–	1.250	135.2	135.4	40	0.40
SS HD 11-1 ⁷ / ₁₆	754.63.79	11	–	1.438	135.2	135.4	40	0.40
SS HD 11-1 ¹ / ₂	754.63.80	11	–	1.500	135.2	135.4	40	0.40
SS HD 12-1	754.63.86	12	–	1.000	147.2	148.6	40	0.50
SS HD 12-1 ³ / ₁₆	754.63.87	12	–	1.188	147.2	148.6	40	0.50
SS HD 12-1 ¹ / ₄	754.63.88	12	–	1.250	147.2	148.6	40	0.50
SS HD 12-1 ⁷ / ₁₆	754.63.89	12	–	1.438	147.2	148.6	40	0.50
SS HD 12-1 ¹ / ₂	754.63.90	12	–	1.500	147.2	148.6	40	0.50
SPLIT IDLERS (METRIC BORES WITHOUT KEYWAYS)								
SI HD 11-25	754.63.21	11	25	–	135.2	135.4	40	0.40
SI HD 11-30	754.63.22	11	30	–	135.2	135.4	40	0.40
SI HD 11-35	754.63.23	11	35	–	135.2	135.4	40	0.40
SI HD 11-40	754.63.24	11	40	–	135.2	135.4	40	0.40
SI HD 11-50	754.63.25	11	50	–	135.2	135.4	40	0.40
SI HD 12-25	754.63.31	12	25	–	147.2	148.6	40	0.50
SI HD 12-30	754.63.32	12	30	–	147.2	148.6	40	0.50
SI HD 12-35	754.63.33	12	35	–	147.2	148.6	40	0.50
SI HD 12-40	754.63.34	12	40	–	147.2	148.6	40	0.50
SI HD 12-50	754.63.35	12	50	–	147.2	148.6	40	0.50
SPLIT IDLERS (INCH BORES WITHOUT KEYWAYS)								
SI HD 11-1	754.63.26	11	–	1.000	135.2	135.4	40	0.40
SI HD 11-1 ³ / ₁₆	754.63.27	11	–	1.188	135.2	135.4	40	0.40
SI HD 11-1 ¹ / ₄	754.63.28	11	–	1.250	135.2	135.4	40	0.40
SI HD 11-1 ⁷ / ₁₆	754.63.29	11	–	1.438	135.2	135.4	40	0.40
SI HD 11-1 ¹ / ₂	754.63.30	11	–	1.500	135.2	135.4	40	0.40
SI HD 12-1	754.63.36	12	–	1.000	147.2	148.6	40	0.50
SI HD 12-1 ³ / ₁₆	754.63.37	12	–	1.188	147.2	148.6	40	0.50
SI HD 12-1 ¹ / ₄	754.63.38	12	–	1.250	147.2	148.6	40	0.50
SI HD 12-1 ⁷ / ₁₆	754.63.39	12	–	1.438	147.2	148.6	40	0.50
SI HD 12-1 ¹ / ₂	754.63.40	12	–	1.500	147.2	148.6	40	0.50

SPLIT SPROCKETS AND IDLERS

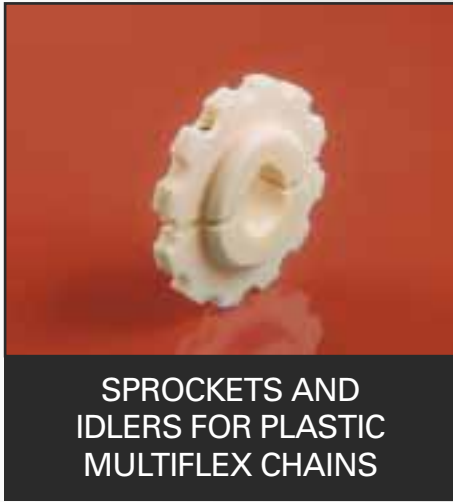

SPROCKETS AND IDLERS FOR PLASTIC MULTIFLEX CHAINS

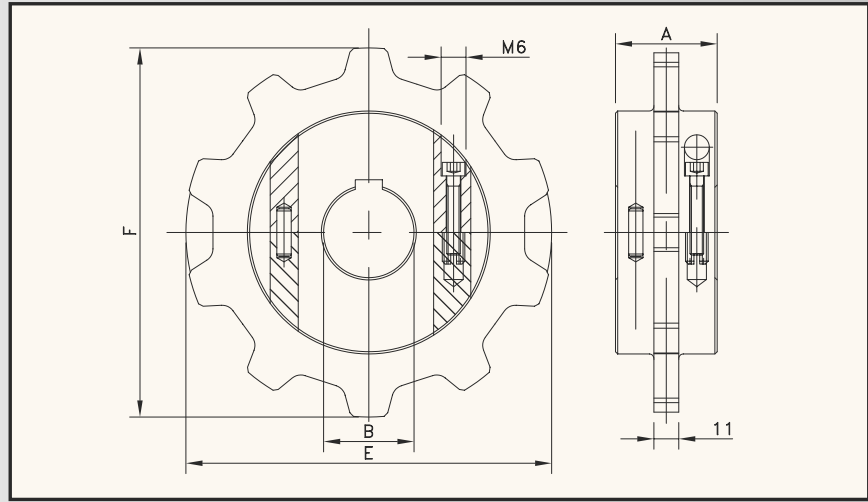

MATERIAL
page 159

page 31, 32, 33

Sprocket type	Code nr.	Nr. of teeth	Bore		Pitch diameter E	Outside diameter F	Hub width A	Weight ≈ kg
			B					
			mm	inch				
SPLIT SPROCKETS (METRIC BORES AND KEYWAYS)								
SS PR/T 10-25	754.67.61	10	25	–	161.8	165	45	0.60
SS PR/T 10-30	754.67.62	10	30	–	161.8	165	45	0.60
SS PR/T 10-35	754.67.63	10	35	–	161.8	165	45	0.60
SS PR/T 10-40	754.67.64	10	40	–	161.8	165	45	0.60
SS PR/T 10-50	754.67.65	10	50	–	161.8	165	45	0.60
SS PR/T 12-25	754.67.71	12	25	–	193.2	196	45	0.70
SS PR/T 12-30	754.67.72	12	30	–	193.2	196	45	0.70
SS PR/T 12-35	754.67.73	12	35	–	193.2	196	45	0.70
SS PR/T 12-40	754.67.74	12	40	–	193.2	196	45	0.70
SS PR/T 12-50	754.67.75	12	50	–	193.2	196	45	0.70
SS PR/T 14-25	754.67.81	14	25	–	224.7	227	45	0.80
SS PR/T 14-30	754.67.82	14	30	–	224.7	227	45	0.80
SS PR/T 14-35	754.67.83	14	35	–	224.7	227	45	0.80
SS PR/T 14-40	754.67.84	14	40	–	224.7	227	45	0.80
SS PR/T 14-50	754.67.85	14	50	–	224.7	227	45	0.80
SPLIT IDLERS (METRIC BORES WITHOUT KEYWAYS)								
SI PR/T 10-25	754.67.11	10	25	–	161.8	165	45	0.60
SI PR/T 10-30	754.67.12	10	30	–	161.8	165	45	0.60
SI PR/T 10-35	754.67.13	10	35	–	161.8	165	45	0.60
SI PR/T 10-40	754.67.14	10	40	–	161.8	165	45	0.60
SI PR/T 10-50	754.67.15	10	50	–	161.8	165	45	0.60
SI PR/T 12-25	754.67.21	12	25	–	193.2	196	45	0.70
SI PR/T 12-30	754.67.22	12	30	–	193.2	196	45	0.70
SI PR/T 12-35	754.67.23	12	35	–	193.2	196	45	0.70
SI PR/T 12-40	754.67.24	12	40	–	193.2	196	45	0.70
SI PR/T 12-50	754.67.25	12	50	–	193.2	196	45	0.70
SI PR/T 14-25	754.67.31	14	25	–	224.7	227	45	0.80
SI PR/T 14-30	754.67.32	14	30	–	224.7	227	45	0.80
SI PR/T 14-35	754.67.33	14	35	–	224.7	227	45	0.80
SI PR/T 14-40	754.67.34	14	40	–	224.7	227	45	0.80
SI PR/T 14-50	754.67.35	14	50	–	224.7	227	45	0.80

Also idler drums can be used. Please refer to the tables on page 128.

SPLIT SPROCKETS AND IDLERS



IDLER DRUMS FOR PLASTIC MULTIFLEX CHAINS WITHOUT TABS

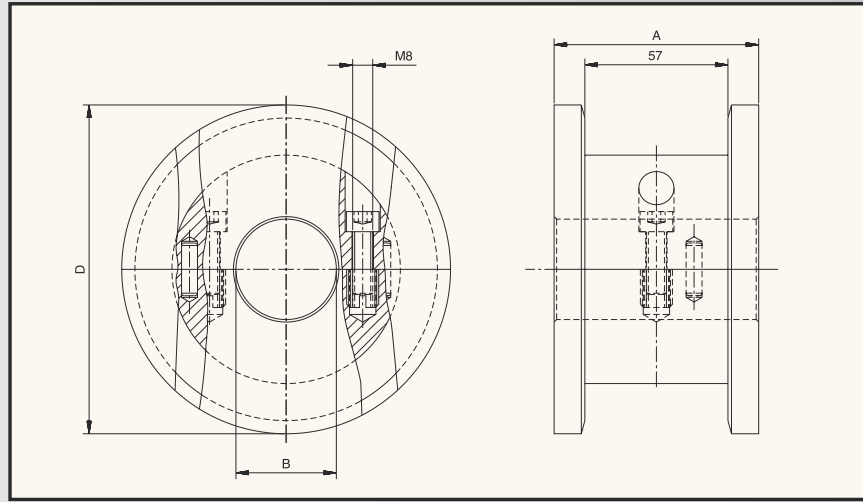

MATERIAL

page 159



page 31, 32, 33

Sprocket type	Code nr.	Nr. of teeth	Bore		Pitch diameter E	Outside diameter D	Hub width A	Weight ≈ kg
			B					
			mm	inch	mm	mm	mm	
METRIC BORES								
SD PR 131-25	754.10.32	–	25	–	–	131	81.5	0.80
SD PR 131-30	754.10.33	–	30	–	–	131	81.5	0.80
SD PR 131-35	754.10.34	–	35	–	–	131	81.5	0.80
SD PR 131-40	754.10.35	–	40	–	–	131	81.5	0.80
SD PR 131-50	754.10.36	–	50	–	–	131	81.5	0.80



IDLER DRUMS FOR PLASTIC MULTIFLEX CHAINS WITH TABS

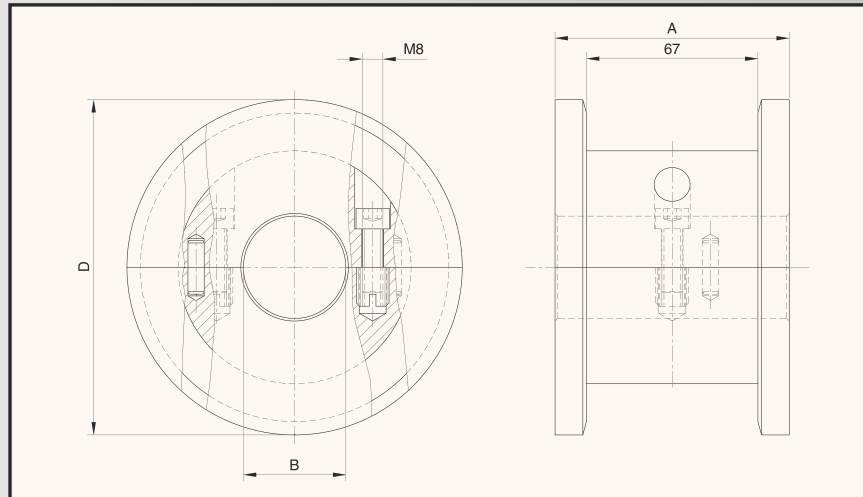

MATERIAL

page 159



page 31, 32, 33

Sprocket type	Code nr.	Nr. of teeth	Bore		Pitch diameter E	Outside diameter D	Hub width A	Weight ≈ kg
			B					
			mm	inch	mm	mm	mm	
METRIC BORES								
SD PRT 131-25	754.10.77	–	25	–	–	131	91.5	0.85
SD PRT 131-30	754.10.78	–	30	–	–	131	91.5	0.85
SD PRT 131-35	754.10.79	–	35	–	–	131	91.5	0.85
SD PRT 131-40	754.10.80	–	40	–	–	131	91.5	0.85
SD PRT 131-50	754.10.81	–	50	–	–	131	91.5	0.85

SPLIT SPROCKETS AND IDLERS

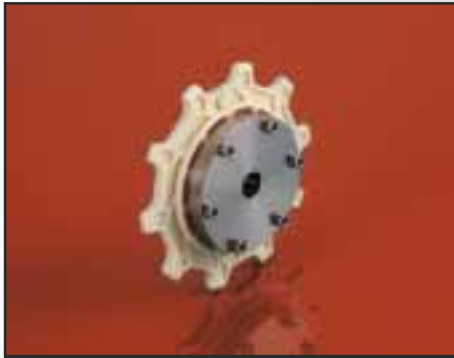

**SPROCKETS / IDLERS
FOR PLASTIC CASE
CONVEYOR CHAINS (CC600)**

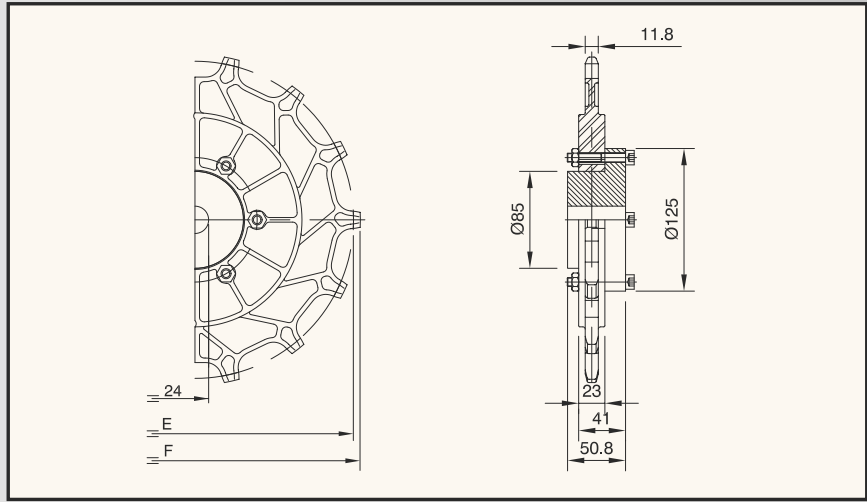

MATERIAL

page 159



page 35

Sprocket type	Code nr.	Nr. of teeth	Bore		Pitch diameter E	Outside diameter F	Hub width A	Weight ≈ kg
			mm	inch				
SPROCKET RING SET								
SR CC600 10	753.83.62	10	–	–	205.5	209.4	–	0.30
SR CC600 14	753.83.65	14	–	–	285.4	289.8	–	0.55
CARBON STEEL HUB (BLACK FINISH)								
CH CC-C 24	753.78.62	–	24	–	–	–	50	3.00
STAINLESS STEEL HUB								
CH CC-S 24	753.78.61	–	24	–	–	–	50	3.00

All combinations of split sprocket ring sets and non-split hubs within the table are possible. Create your split sprocket / idler from a sprocket ring set and a carbon steel or stainless steel hub.

A sprocket ring set includes screws, nuts and washers.



**SPROCKET FOR
PLASTIC STRONG CASE
CONVEYOR CHAINS (CC1400)**

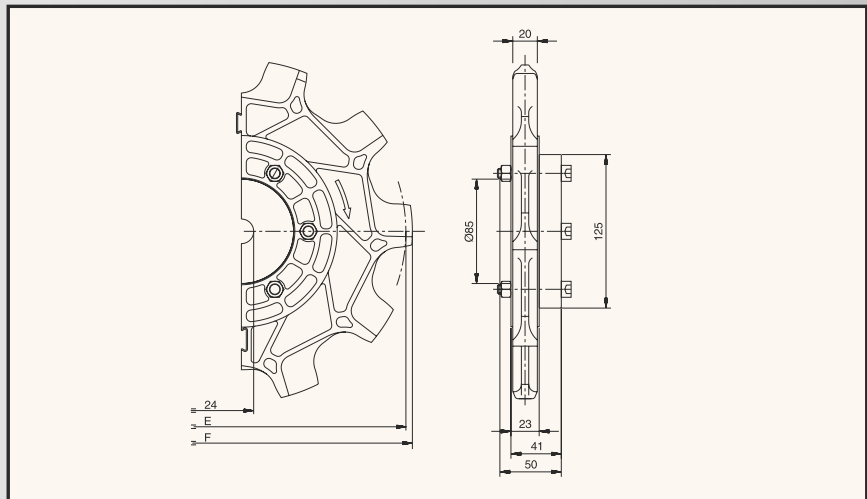

MATERIAL

page 159



page 36

Sprocket type	Code nr.	Nr. of teeth	Bore		Pitch diameter E	Outside diameter F	Hub width A	Weight ≈ kg
			mm	inch				
SPROCKET RING SET								
SR CC1400 10	753.83.42	10	–	–	267.0	278.4	–	0.50
CARBON STEEL HUB (BLACK FINISH)								
CH CC-C 24	753.78.62	–	24	–	–	–	50	3.00
STAINLESS STEEL HUB								
CH CC-S 24	753.78.61	–	24	–	–	–	50	3.00

All combinations of split sprocket ring sets and non-split hubs within the table are possible. Create your split sprocket from a sprocket ring set and a carbon steel or stainless steel hub.

A sprocket ring set includes screws, nuts and washers.

SPLIT SPROCKETS AND IDLERS



**SPROCKETS
FOR 500 BELTS
ROUND BORE**

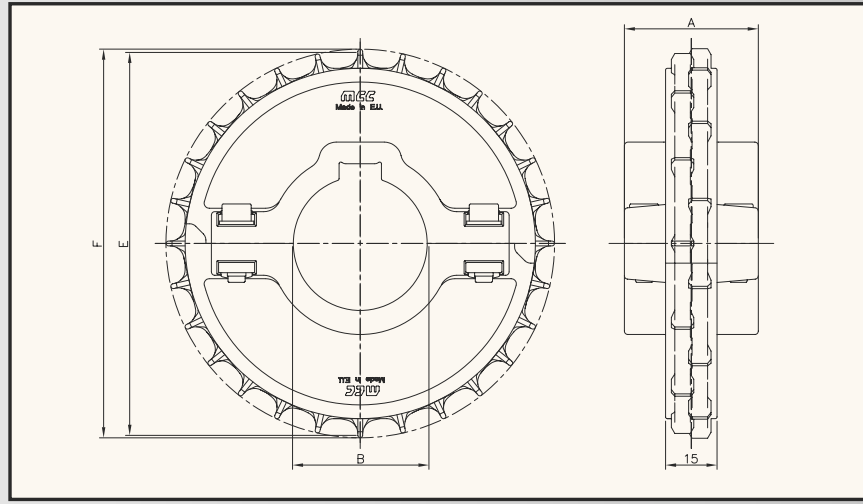

MATERIAL

page 159



page 39

Sprocket type	Code nr.	Nr. of teeth	Bore		Pitch diameter E	Outside diameter F	Hub width A	Weight ≈ kg
			B					
			mm	inch	mm	mm	mm	
METRIC BORES AND KEYWAYS								
SSW 500 28-30	899.14.17	28	30	–	113.4	113.4	39.0	0.15
SSW 500 28-40	899.14.11	28	40	–	113.4	113.4	39.0	0.16
INCH BORES AND KEYWAYS								
SSW 500 28-1½	899.14.31	28	–	1.5	113.4	113.4	39.0	0.16



**SPROCKETS
FOR 500 BELTS
SQUARE BORE**

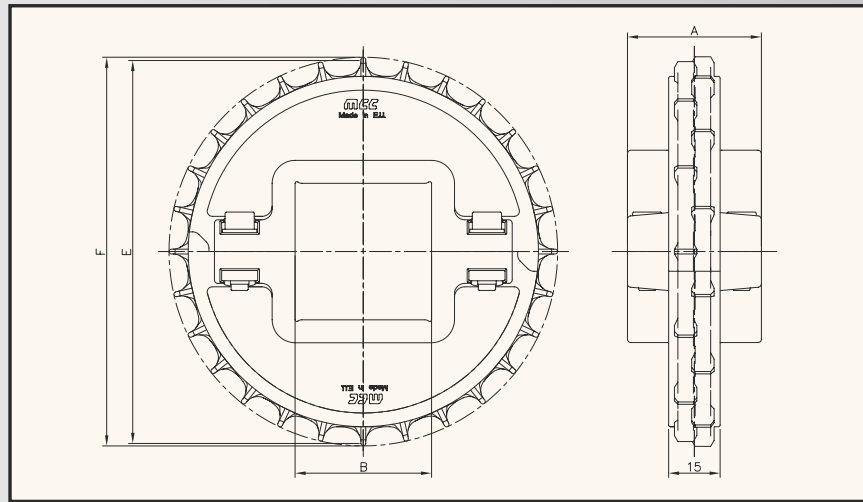

MATERIAL

page 159



page 39

Sprocket type	Code nr.	Nr. of teeth	Bore		Pitch diameter E	Outside diameter F	Hub width A	Weight ≈ kg
			B					
			mm	inch	mm	mm	mm	
METRIC BORES								
SSW 500 28-40x40	899.14.21	28	40x40	–	113.4	113.4	39.0	0.16
INCH BORES								
SSW 500 28-1½x1½	899.14.41	28	–	1.5x1.5	113.4	113.4	39.0	0.16

SPLIT SPROCKETS AND IDLERS



**SPROCKETS
FOR 1000 BELTS
ROUND BORE WIDE HUB**

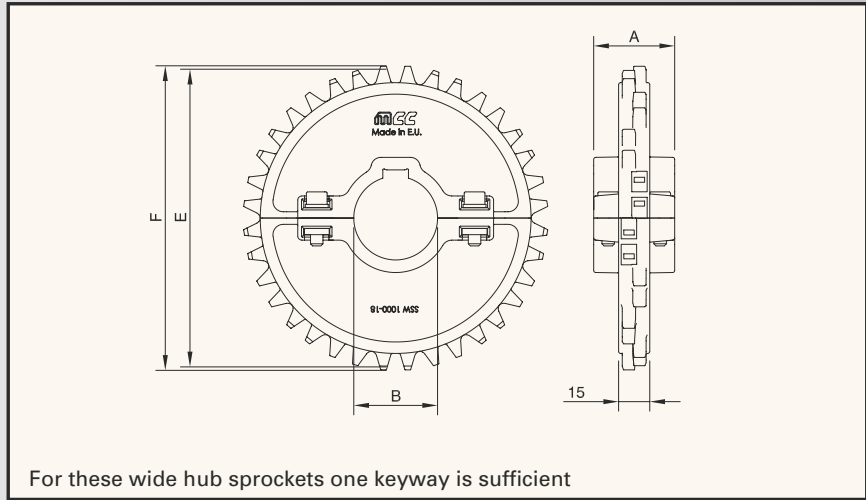

MATERIAL

page 159



41-45, 47

Sprocket type	Code nr.	Nr. of teeth	Bore		Pitch diameter E	Outside diameter F	Hub width A	Weight ≈ kg
			mm	inch				
SPLIT SPROCKETS (METRIC BORES AND KEYWAYS)								
SSW 1000 16-30	899.06.17	16	30	–	130.2	130.6	39	0.23
SSW 1000 16-35	899.06.10	16	35	–	130.2	130.6	39	0.23
SSW 1000 16-40	899.06.11	16	40	–	130.2	130.6	39	0.24
SSW 1000 18-30	899.08.17	18	30	–	146.3	146.8	39	0.27
SSW 1000 18-35	899.08.10	18	35	–	146.3	146.8	39	0.27
SSW 1000 18-40	899.08.11	18	40	–	146.3	146.8	39	0.27
SSW 1000 20-30	899.09.17	20	30	–	162.4	163.1	39	0.31
SSW 1000 20-35	899.09.10	20	35	–	162.4	163.1	39	0.31
SSW 1000 20-40	899.09.11	20	40	–	162.4	163.1	39	0.31
SPLIT SPROCKETS (INCH BORES AND KEYWAYS)								
SSW 1000 16-1½	899.06.31	16	–	1.5	130.2	130.6	39	0.24
SSW 1000 18-1½	899.08.31	18	–	1.5	146.3	145.9	39	0.27
SSW 1000 20-1½	899.09.31	20	–	1.5	162.4	163.1	39	0.31



**SPROCKETS
FOR 1000 BELTS
SQUARE BORE WIDE HUB**

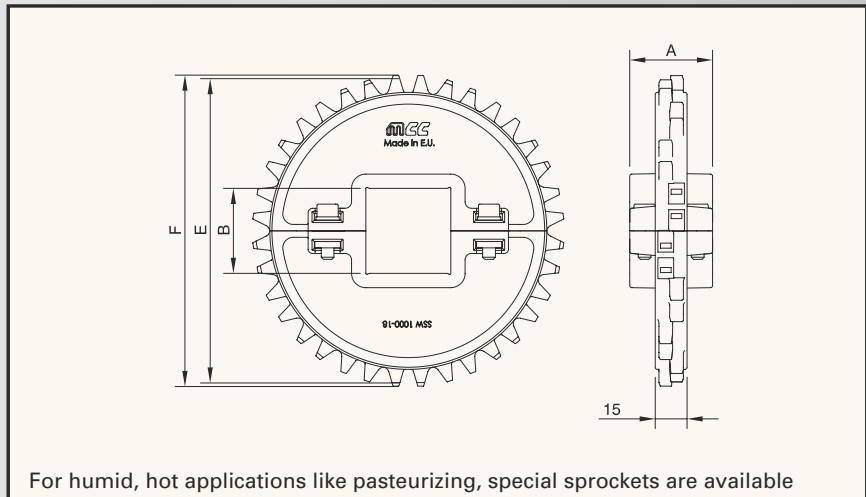

MATERIAL

page 159



41-45, 47

Sprocket type	Code nr.	Nr. of teeth	Bore		Pitch diameter E	Outside diameter F	Hub width A	Weight ≈ kg
			mm	inch				
SPLIT SPROCKETS (METRIC BORES)								
SSW 1000 16-40x40	899.06.21	16	40x40	–	130.2	130.6	39	0.24
SSW 1000 18-40x40	899.08.21	18	40x40	–	146.3	146.8	39	0.27
SSW 1000 20-40x40	899.09.21	20	40x40	–	162.4	163.1	39	0.31
SPLIT SPROCKETS (INCH BORES)								
SSW 1000 16-1½x1½	899.06.41	16	–	1.5x1.5	130.2	130.6	39	0.24
SSW 1000 18-1½x1½	899.08.41	18	–	1.5x1.5	146.3	146.8	39	0.27
SSW 1000 20-1½x1½	899.09.41	20	–	1.5x1.5	162.4	163.1	39	0.31

SPLIT SPROCKETS AND IDLERS



**SPROCKETS AND IDLERS
FOR 1005 BELTS
ROUND BORE**

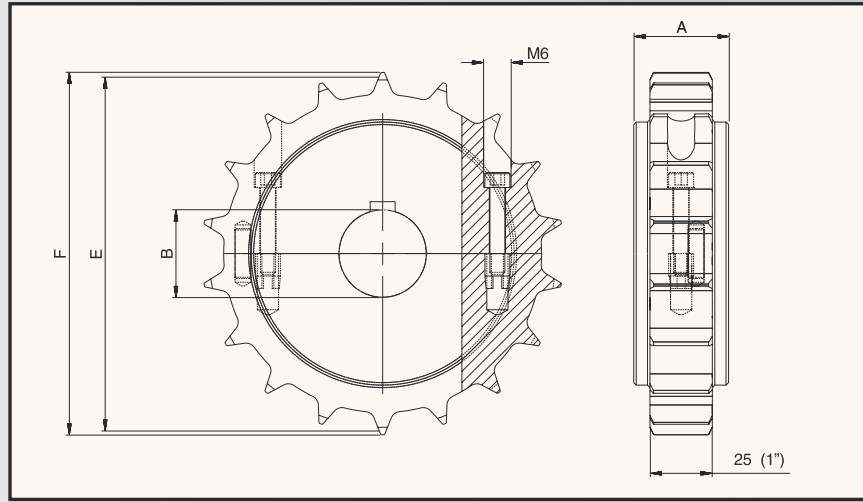

MATERIAL
page 159

49, 51, 53, 54

Sprocket type	Code nr.	Nr. of teeth	Bore		Pitch diameter E	Outside diameter F	Hub width A	Weight ≈ kg
			B mm	inch				
SPLIT SPROCKETS (METRIC BORES AND KEYWAYS)								
SS 1005 18-30	894.30.67	18	30	–	146.3	145.3	38	0.60
SS 1005 18-40	894.30.61	18	40	–	146.3	145.3	38	0.55
SS 1005 21-30	894.33.67	21	30	–	170.4	169.7	38	0.70
SS 1005 21-40	894.33.61	21	40	–	170.4	169.7	38	0.65
SPLIT SPROCKETS (INCH BORES AND KEYWAYS)								
SS 1005 18-1	894.30.86	18	–	1.0	146.3	145.3	38	0.60
SS 1005 18-1½	894.30.81	18	–	1.5	146.3	145.3	38	0.55
SS 1005 21-1	894.33.86	21	–	1.0	170.4	169.7	38	0.70
SS 1005 21-1½	894.33.81	21	–	1.5	170.4	169.7	38	0.65
SPLIT IDLERS (METRIC BORES WITHOUT KEYWAYS)								
SI 1005 18-30	894.30.77	18	30	–	146.3	145.3	38	0.60
SI 1005 18-40	894.30.71	18	40	–	146.3	145.3	38	0.55
SI 1005 21-30	894.33.77	21	30	–	170.4	169.7	38	0.70
SI 1005 21-40	894.33.71	21	40	–	170.4	169.7	38	0.65
SPLIT IDLERS (INCH BORES WITHOUT KEYWAYS)								
SI 1005 18-1	894.30.96	18	–	1.0	146.3	145.3	38	0.60
SI 1005 18-1½	894.30.91	18	–	1.5	146.3	145.3	38	0.55
SI 1005 21-1	894.33.96	21	–	1.0	170.4	169.7	38	0.70
SI 1005 21-1½	894.33.91	21	–	1.5	170.4	169.7	38	0.65

Split sprockets with keyways are 'tight fit' onto the shaft and can be used for belt widths up to 680 mm and temperature differences of max. 30°C. For wider belts or bigger temperature differences, square bores have to be used.

SPLIT SPROCKETS AND IDLERS



**SPROCKETS FOR
1005 BELTS
SQUARE BORE**

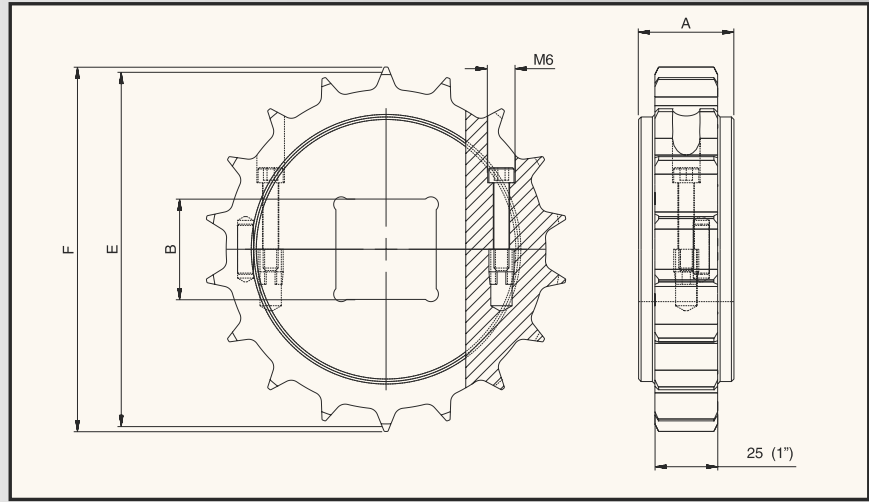

MATERIAL
page 159

49, 51, 53, 54

Sprocket type	Code nr.	Nr. of teeth	Bore		Pitch diameter E	Outside diameter F	Hub width A	Weight ≈ kg
			B mm	inch				
METRIC BORES								
SS 1005 18-40x40	894.30.21	18	40x40	–	146.3	145.3	38	0.50
SS 1005 21-40x40	894.33.21	21	40x40	–	170.4	169.7	38	0.60
INCH BORES								
SS 1005 18-1 ¹ / ₂ x1 ¹ / ₂	894.30.51	18	–	1.5x1.5	146.3	145.3	38	0.50
SS 1005 21-1 ¹ / ₂ x1 ¹ / ₂	894.33.51	21	–	1.5x1.5	170.4	169.7	38	0.60

These sprockets can be used on the drive- and on the idler shaft. They 'float' freely on the shaft.

SPLIT SPROCKETS AND IDLERS



**SPROCKETS
FOR 2000 BELTS
SQUARE BORE**

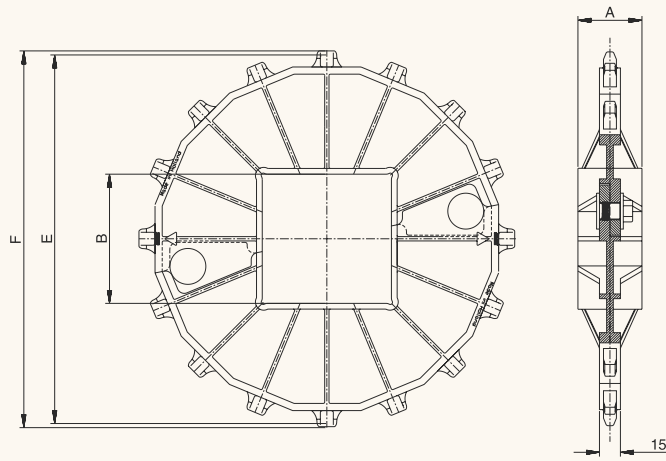

MATERIAL

page 159



page 57, 58, 59

Sprocket type	Code nr.	Nr. of teeth	Bore		Pitch diameter E	Outside diameter F	Hub width A	Weight ≈ kg
			B					
			mm	inch	mm	mm	mm	
METRIC BORES								
SS 2000 13-90x90 POM	893.73.24	13	90x90	–	212.3	209	30	0.35
SS 2000 16-90x90 POM	893.76.24	16	90x90	–	260.4	262	45	0.54
SS 2000 16-120x120 POM	893.76.29	16	120x120	–	260.4	262	45	0.50



**SPROCKETS
FOR 2500 BELTS
SQUARE BORE**

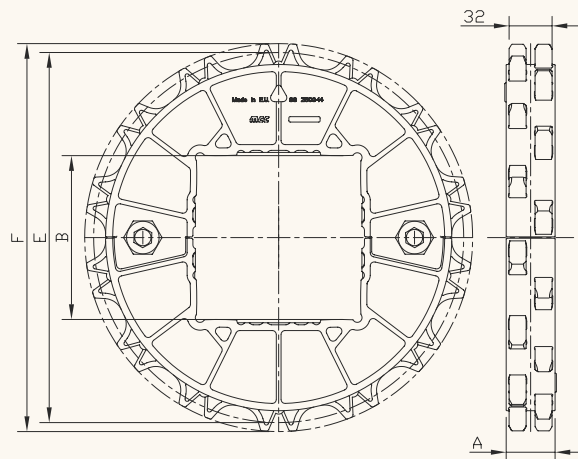

MATERIAL

page 159



page 61

Sprocket type	Code nr.	Nr. of teeth	Bore		Pitch diameter E	Outside diameter F	Hub width A	Weight ≈ kg
			B					
			mm	inch	mm	mm	mm	
METRIC BORES								
SS 2500 14-120x120 RPA	899.97.29	14	120x120	–	285.4	282	36	0.92

SPLIT SPROCKETS AND IDLERS



**SPROCKETS
FOR 505 BELTS
ROUND BORE MACHINED**

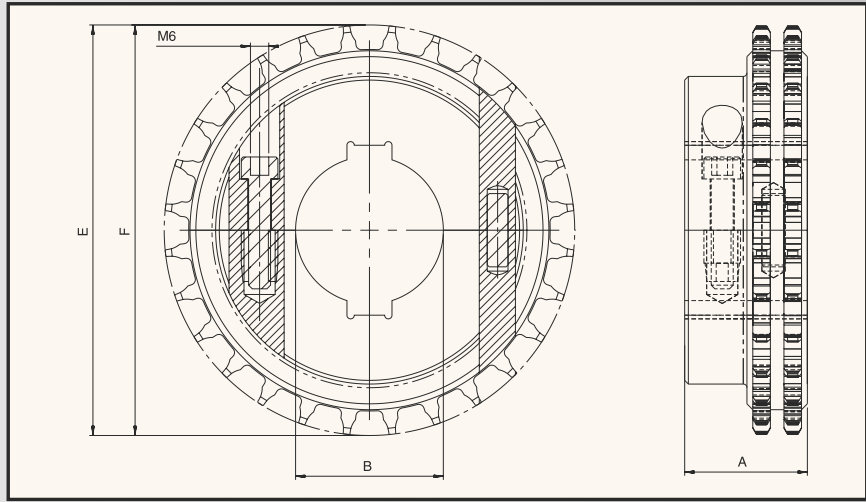

MATERIAL

page 159



page 63

Sprocket type	Code nr.	Nr. of teeth	Bore		Pitch diameter E	Outside diameter F	Hub width A	Weight ≈ kg
			B					
			mm	inch	mm	mm	mm	
METRIC BORES AND KEYWAYS								
SS 505 28-25	894.26.16	28	25	–	113.4	113.4	33.5	0.30
SS 505 28-30	894.26.17	28	30	–	113.4	113.4	33.5	0.30
SS 505 28-35	894.26.10	28	35	–	113.4	113.4	33.5	0.30
INCH BORES AND KEYWAYS								
SS 505 28-1	894.26.41	28	–	1.0	113.4	113.4	33.5	0.30



**SPROCKETS
FOR 505 BELTS
SQUARE BORE MACHINED**

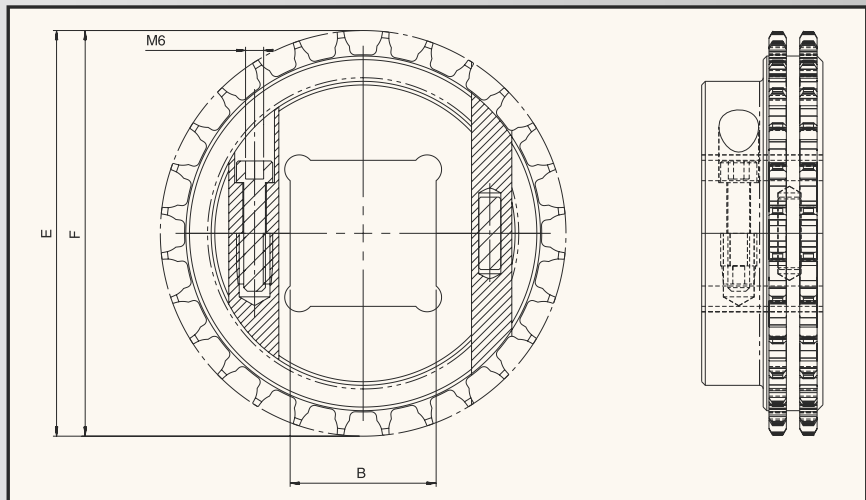

MATERIAL

page 159



page 63

Sprocket type	Code nr.	Nr. of teeth	Bore		Pitch diameter E	Outside diameter F	Hub width A	Weight ≈ kg
			B					
			mm	inch	mm	mm	mm	
METRIC BORES								
SS 505 28-25x25	894.26.26	28	25x25	–	113.4	113.4	33.5	0.30
SS 505 28-30x30	894.26.27	28	30x30	–	113.4	113.4	33.5	0.30
SS 505 28-35x35	894.26.20	28	35x35	–	113.4	113.4	33.5	0.30
INCH BORES								
SS 505 28-1x1	894.26.56	28	–	1.0x1.0	113.4	113.4	33.5	0.30

SPLIT SPROCKETS AND IDLERS



**SPROCKETS FOR
505 BELTS ROUND BORE
INJECTION MOULDED**

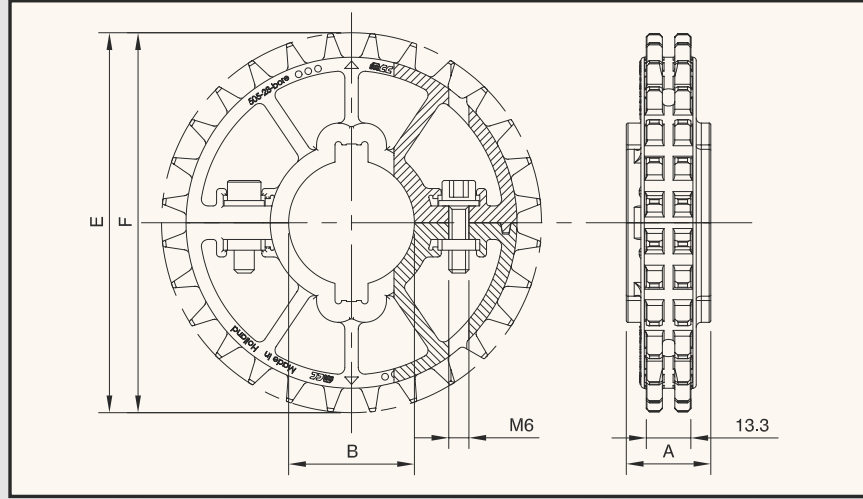

MATERIAL

page 159



page 63

Sprocket type	Code nr.	Nr. of teeth	Bore		Pitch diameter E	Outside diameter F	Hub width A	Weight ≈ kg
			B					
			mm	inch	mm	mm	mm	
METRIC BORES AND KEYWAYS								
SS 505 28-40	895.54.11	28	40	–	113.4	113.4	25.5	0.10
INCH BORES AND KEYWAYS								
SS 505 28-1½	895.54.41	28	–	1.5	113.4	113.4	25.5	0.10



**SPROCKETS FOR
505 BELTS SQUARE BORE
INJECTION MOULDED**

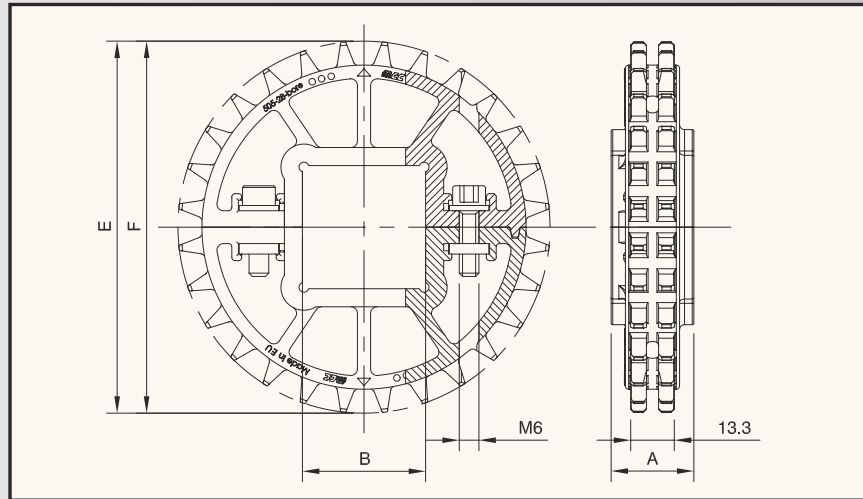

MATERIAL

page 159



page 63

Sprocket type	Code nr.	Nr. of teeth	Bore		Pitch diameter E	Outside diameter F	Hub width A	Weight ≈ kg
			B					
			mm	inch	mm	mm	mm	
METRIC BORES								
SS 505 28-40x40	895.54.21	28	40x40	–	113.4	113.4	25.5	0.10
INCH BORES								
SS 505 28-1½x1½	895.54.51	28	–	1.5x1.5	113.4	113.4	25.5	0.10

SPLIT SPROCKETS AND IDLERS



**SPROCKETS
FOR 1255 BELTS
ROUND BORE MACHINED**

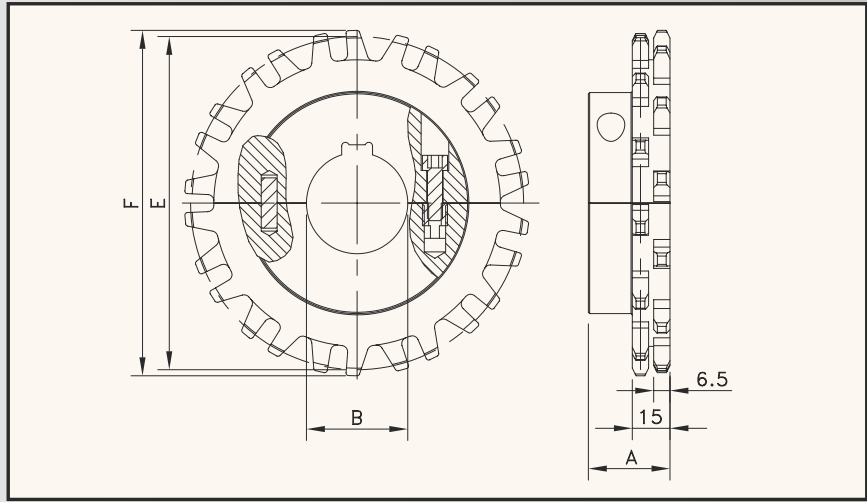

MATERIAL

page 159



page 64

Sprocket type	Code nr.	Nr. of teeth	Bore		Pitch diameter E	Outside diameter F	Hub width A	Weight ≈ kg
			B					
METRIC BORES AND KEYWAYS								
SS 1255 10-30	894.60.17	10	30	–	102.8	106.6	33.5	0.2
SS 1255 13-40	894.64.11	13	40	–	132.7	137.5	33.5	0.4
SS 1255 15-40	894.62.11	15	40	–	152.7	158.1	33.5	0.5
SS 1255 16-40	894.66.11	16	40	–	162.8	168.3	33.5	0.6



**SPROCKETS
FOR 1255 BELTS
SQUARE BORE MACHINED**

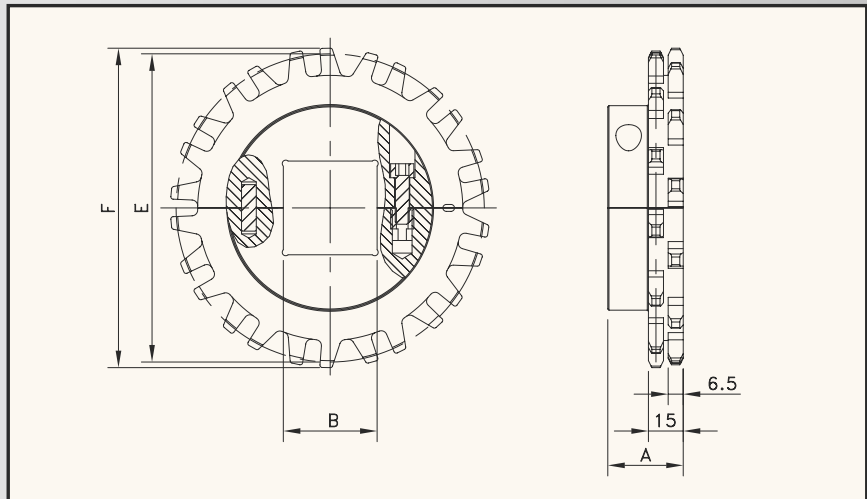

MATERIAL

page 159



page 64

Sprocket type	Code nr.	Nr. of teeth	Bore		Pitch diameter E	Outside diameter F	Hub width A	Weight ≈ kg
			B					
METRIC BORES								
SS 1255 10-30x30	894.60.27	10	30x30	–	102.8	106.6	33.5	0.2
SS 1255 13-40x40	894.64.21	13	40x40	–	132.7	137.5	33.5	0.4
SS 1255 15-40x40	894.62.21	15	40x40	–	152.7	158.1	33.5	0.5
SS 1255 16-40x40	894.66.21	16	40x40	–	162.8	168.3	33.5	0.6

SPLIT SPROCKETS AND IDLERS



**SPROCKETS FOR
7956 BELTS ROUND BORE
INJECTION MOULDED**

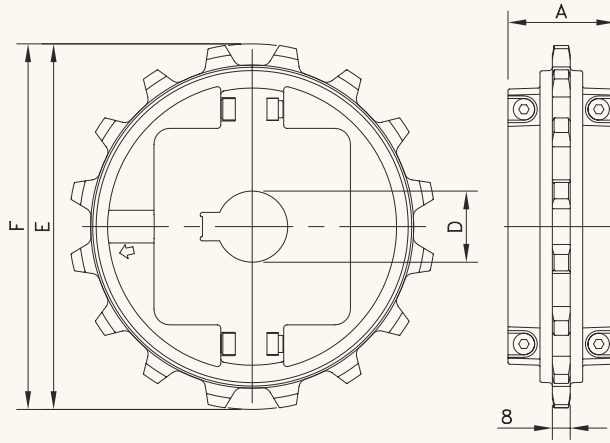

MATERIAL

page 159



page 65

Sprocket type	Code nr.	Nr. of teeth	Bore		Pitch diameter E	Outside diameter F	Hub width A	Weight ≈ kg
			B	mm				
METRIC BORES AND KEYWAYS								
SSW 7956 16-25	614-169-4	16	25	–	162.7	163.2	47.6	0.5
SSW 7956 16-30	614-169-1	16	30	–	162.7	163.2	47.6	0.5
SSW 7956 16-35	614-169-3	16	35	–	162.7	163.2	47.6	0.5
SSW 7956 16-40	614-169-5	16	40	–	162.7	163.2	47.6	0.5



**SPROCKETS FOR
7956 BELTS SQUARE BORE
INJECTION MOULDED**

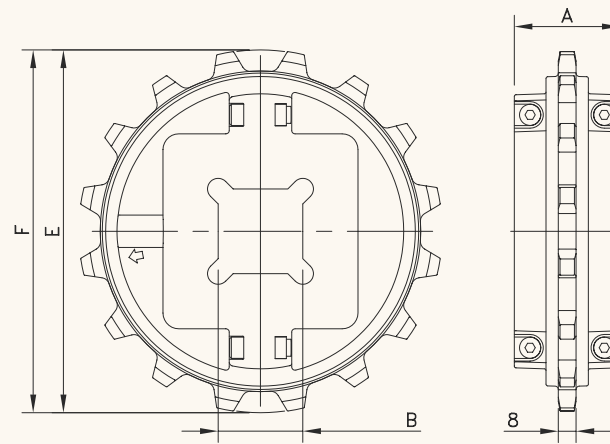

MATERIAL

page 159



page 65

Sprocket type	Code nr.	Nr. of teeth	Bore		Pitch diameter E	Outside diameter F	Hub width A	Weight ≈ kg
			B	mm				
METRIC BORES								
SSW 7956 16-40x40	614-170-3	16	40x40	–	162.7	163.2	47.6	0.4
SSW 7956 16-50x50	614-170-4	16	50x50	–	162.7	163.2	47.6	0.4
SSW 7956 16-60x60	614-170-2	16	60x60	–	162.7	163.2	47.6	0.4

SPLIT SPROCKETS AND IDLERS



**SPROCKETS AND IDLERS
FOR 1050/1055 CHAINBELTS
ROUND BORE WIDE HUB**

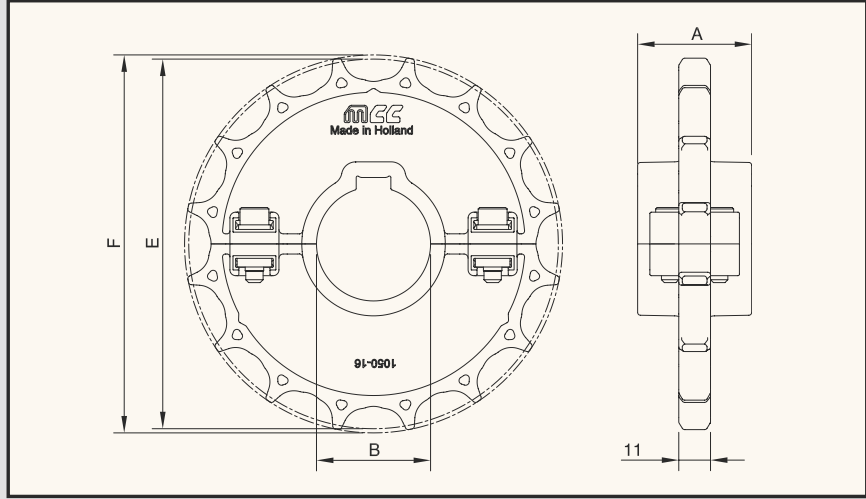

MATERIAL
page 159

page 67-69

Sprocket type	Code nr.	Nr. of teeth	Bore		Pitch diameter E	Outside diameter F	Hub width A	Weight ≈ kg
			mm	inch				
SPLIT SPROCKETS (METRIC BORES AND KEYWAYS)								
SSW 1050 16-30	749.82.23	16	30	–	131.2	130.9	40	0.20
SSW 1050 16-40	749.82.43	16	40	–	131.2	130.9	40	0.18
SSW 1050 18-30	749.82.25	18	30	–	147.4	146.8	40	0.21
SSW 1050 18-40	749.82.45	18	40	–	147.4	146.8	40	0.19
SPLIT SPROCKETS (INCH BORES AND KEYWAYS)								
SSW 1050 16-1½	749.86.53	16	–	1.500	131.2	130.9	40	0.18
SSW 1050 18-1½	749.86.55	18	–	1.500	147.4	146.8	40	0.19
SPLIT IDLERS (METRIC BORES WITHOUT KEYWAYS)								
SIW 1050 16-30	749.81.23	16	30	–	131.2	130.9	40	0.20
SIW 1050 16-40	749.81.43	16	40	–	131.2	130.9	40	0.18
SIW 1050 18-30	749.81.25	18	30	–	147.4	146.8	40	0.21
SIW 1050 18-40	749.81.45	18	40	–	147.4	146.8	40	0.19
SPLIT IDLERS (INCH BORES WITHOUT KEYWAYS)								
SIW 1050 16-1½	749.85.53	16	–	1.500	131.2	130.9	40	0.18
SIW 1050 18-1½	749.85.55	18	–	1.500	147.4	146.8	40	0.19

The classic sprocket is different for chains and belts. For chains MCC has the modu-system, which consists of interchangeable sprocket rings and hub sets; for belts the sprockets are one-piece.



CLASSIC MODU-SPROCKET FOR STEEL SINGLE HINGE AND MAGNETFLEX® CHAINS.

BENEFITS

- Longer wearlife**
The materials used are super tough polyamide for the sprockets and idlers and low friction polyacetal for the hub sets.
- Low noise**
Plastic sprockets and idlers create less noise than steel.
- Corrosion resistant**
Resistant to most chemicals commonly used for lubrication and cleaning.
- No further machining costs**
All moulded sprockets and idlers have ready-to-use bores.
- Optimum chain and belt engagement**
Design and test facilities ensure exact fit.

PROGRAMME

- Modu-sprockets for chains**
Sprocket ring and hub set with keyway, round bore.
- Idler drums for chains**
One-piece, strong and economical, round bore. Or with interchangeable centre spacers, made to fit any hinge width or configuration.
- Modu-idlers for chains**
Sprocket ring and hub set without keyway, round bore.
- Sprockets for belts**
One-piece, strong and economical, round and square bore.



HUB SET AND SPROCKET RING MAKE A MODU-SPROCKET.

AND . . .

For minimum stock holding, the modu system is ideal, because most sprocket rings and hub sets can be used in different combinations.

CLASSIC SPROCKETS AND IDLERS



**MODU-SYSTEM
FOR STEEL SINGLE HINGE
AND MAGNETFLEX® CHAINS**

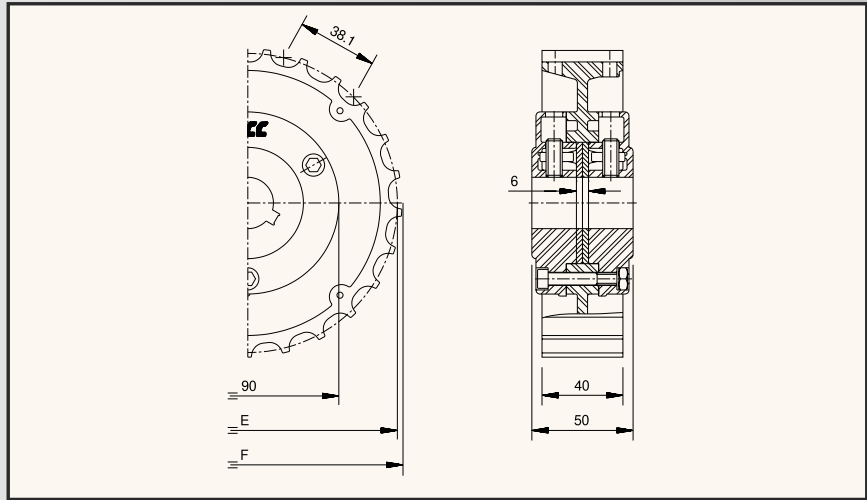

MATERIAL

page 159



Sprocket type	Code nr.	Nr. of teeth	Bore		Pitch diameter E	Outside diameter F	Hub width A	Weight ≈ kg
			mm	inch				
SPROCKET RINGS								
MR SSHMF 19	753.73.22	19	–	–	117.3	117	–	0.15
MR SSHMF 21	753.73.32	21	–	–	129.3	129	–	0.19
MR SSHMF 23	753.73.42	23	–	–	141.2	141	–	0.22
MR SSHMF 25	753.73.52	25	–	–	153.2	153	–	0.23
MR SSHMF 27	753.73.62	27	–	–	165.2	166	–	0.26
HUB SETS WITH KEYWAY								
MHS OH 25	753.80.01	–	25	–	–	–	50	0.37
MHS OH 30	753.80.02	–	30	–	–	–	50	0.35
MHS OH 35	753.80.03	–	35	–	–	–	50	0.33
MHS OH 40	753.80.04	–	40	–	–	–	50	0.26
HUB SETS WITHOUT KEYWAY								
MHI OH 25	753.80.26	–	25	–	–	–	50	0.23
MHI OH 30	753.80.27	–	30	–	–	–	50	0.22
MHI OH 35	753.80.28	–	35	–	–	–	50	0.22
MHI OH 40	753.80.29	–	40	–	–	–	50	0.22

All combinations of sprocket rings and hub sets within the table are possible.

Create your modu-sprocket from a sprocket ring and a hub set with keyway. Take a hub set without keyway with a sprocket ring for your modu-idler.

Also idler drums can be used. Please refer to the table on next page.

CLASSIC SPROCKETS AND IDLERS



IDLER DRUMS FOR STEEL AND PLASTIC SINGLE HINGE AND MAGNETFLEX® CHAINS

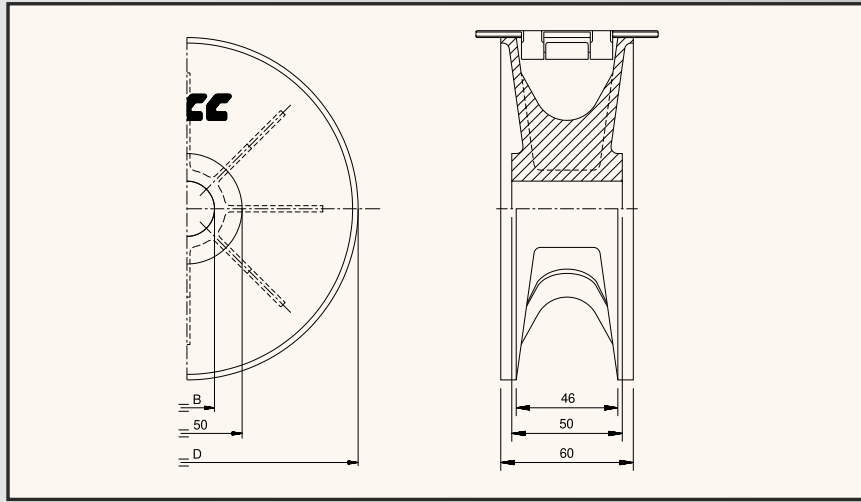

Sprocket type	Code nr.	Corresponding nr. of teeth	Bore		Pitch diameter E	Outside diameter D	Hub width A	Weight ≈
			mm	inch				
CORRESPONDING WITH 21 TEETH								
CD SHMF 131-25	754.02.02	21	25	–	–	131	50	0.32
CD SHMF 131-30	754.02.03	21	30	–	–	131	50	0.31
CD SHMF 131-35	754.02.04	21	35	–	–	131	50	0.30
CD SHMF 131-40	754.02.05	21	40	–	–	131	50	0.27
CORRESPONDING WITH 25 TEETH								
CD SHMF 155-25	754.02.52	25	25	–	–	155	50	0.42
CD SHMF 155-30	754.02.53	25	30	–	–	155	50	0.41
CD SHMF 155-35	754.02.54	25	35	–	–	155	50	0.40
CD SHMF 155-40	754.02.55	25	40	–	–	155	50	0.25

CLASSIC SPROCKETS AND IDLERS

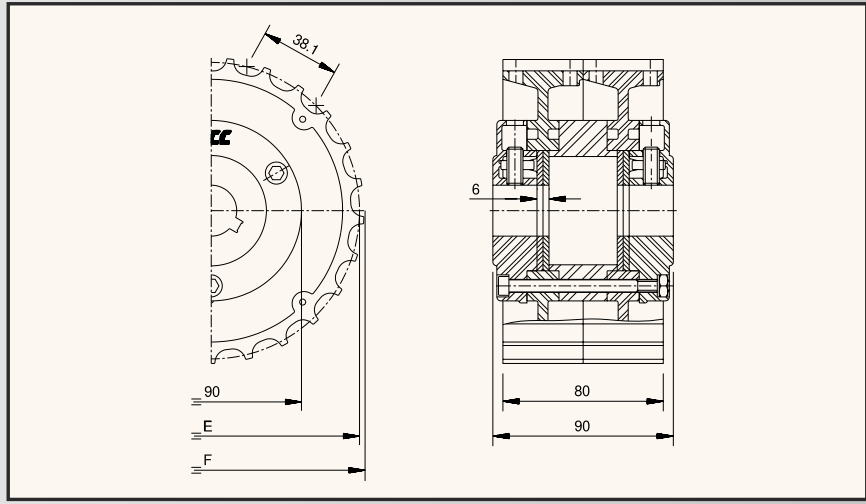

Sprocket type	Code nr.	Nr. of teeth	Bore		Pitch diameter E	Outside diameter F	Hub width A	Weight ≈ kg
			mm	inch				
SPROCKET RINGS								
MR SSHMF 19	753.73.22	19	–	–	117.3	117	–	0.15
MR SSHMF 21	753.73.32	21	–	–	129.3	129	–	0.19
MR SSHMF 23	753.73.42	23	–	–	141.2	141	–	0.22
MR SSHMF 25	753.73.52	25	–	–	153.2	153	–	0.23
MR SSHMF 27	753.73.62	27	–	–	165.2	166	–	0.26
HUB SETS WITH KEYWAY								
MHS DBH 25	753.80.51	–	25	–	–	–	90	0.58
MHS DBH 30	753.80.52	–	30	–	–	–	90	0.54
MHS DBH 35	753.80.53	–	35	–	–	–	90	0.51
MHS DBH 40	753.80.54	–	40	–	–	–	90	0.48
HUB SETS WITHOUT KEYWAY								
MHI DBH 25	753.80.76	–	25	–	–	–	90	0.30
MHI DBH 30	753.80.77	–	30	–	–	–	90	0.29
MHI DBH 35	753.80.78	–	35	–	–	–	90	0.27
MHI DBH 40	753.80.79	–	40	–	–	–	90	0.25

All combinations of sprocket rings and hub sets within the table are possible.

Create your modu-sprocket from two (!) sprocket rings and a hub set with keyway. Take a hub set without keyway with two (!) sprocket rings for your modu-idler.

CLASSIC SPROCKETS AND IDLERS



**MODU-SYSTEM
FOR PLASTIC
SINGLE HINGE CHAINS**

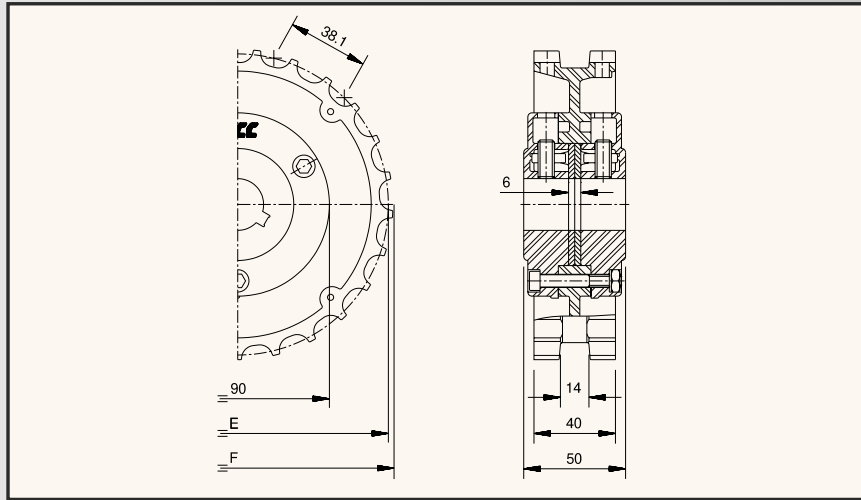

MATERIAL

page 159



page 13, 21

Sprocket type	Code nr.	Nr. of teeth	Bore		Pitch diameter E	Outside diameter F	Hub width A	Weight ≈ kg
			mm	inch				
SPROCKET RINGS								
MR SH 19	753.72.22	19	–	–	117.3	117	–	0.11
MR SH 21	753.72.32	21	–	–	129.3	129	–	0.16
MR SH 23	753.72.42	23	–	–	141.2	141	–	0.18
MR SH 25	753.72.52	25	–	–	153.2	153	–	0.21
MR SH 27	753.72.62	27	–	–	165.2	166	–	0.24
HUB SETS WITH KEYWAY								
MHS OH 25	753.80.01	–	25	–	–	–	50	0.37
MHS OH 30	753.80.02	–	30	–	–	–	50	0.35
MHS OH 35	753.80.03	–	35	–	–	–	50	0.33
MHS OH 40	753.80.04	–	40	–	–	–	50	0.26
HUB SETS WITHOUT KEYWAY								
MHI OH 25	753.80.26	–	25	–	–	–	50	0.23
MHI OH 30	753.80.27	–	30	–	–	–	50	0.22
MHI OH 35	753.80.28	–	35	–	–	–	50	0.22
MHI OH 40	753.80.29	–	40	–	–	–	50	0.22

All combinations of sprocket rings and hub sets within the table are possible.

Create your modu-sprocket from a sprocket ring and a hub set with keyway. Take a hub set without keyway with a sprocket ring for your modu-idler.

Also idlers drums can be used. Please refer to the table on page 142.

CLASSIC SPROCKETS AND IDLERS



**MODU-SYSTEM FOR
PLASTIC RADIUS HINGE
AND MAGNETFLEX® CHAINS**

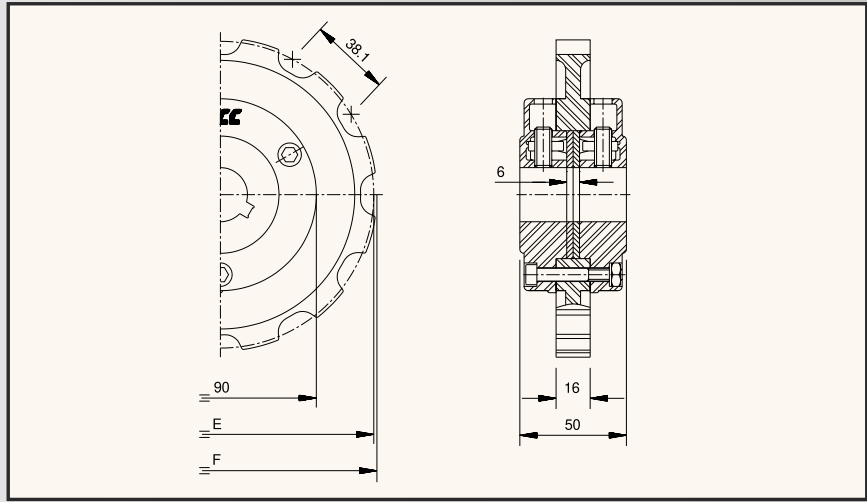

MATERIAL

page 159

15, 16, 17, 23

Sprocket type	Code nr.	Nr. of teeth	Bore		Pitch diameter E	Outside diameter F	Hub width A	Weight ≈ kg
			mm	inch				
SPROCKET RINGS								
MR RH 10	753.70.22	10	–	–	123.3	122	–	0.11
MR RH 11	753.70.32	11	–	–	135.2	134	–	0.13
MR RH 12	753.70.42	12	–	–	147.2	146	–	0.15
HUB SETS WITH KEYWAY								
MHS OH 25	753.80.01	–	25	–	–	–	50	0.37
MHS OH 30	753.80.02	–	30	–	–	–	50	0.35
MHS OH 35	753.80.03	–	35	–	–	–	50	0.33
MHS OH 40	753.80.04	–	40	–	–	–	50	0.26
HUB SETS WITHOUT KEYWAY								
MHI OH 25	753.80.26	–	25	–	–	–	50	0.23
MHI OH 30	753.80.27	–	30	–	–	–	50	0.22
MHI OH 35	753.80.28	–	35	–	–	–	50	0.22
MHI OH 40	753.80.29	–	40	–	–	–	50	0.22

All combinations of sprocket rings and hub sets within the table are possible.

Create your modu-sprocket from a sprocket ring and a hub set with keyway. Take a hub set without keyway with a sprocket ring for your modu-idler.

Also idler drums can be used. Please refer to the tables on page 142.

CLASSIC SPROCKETS AND IDLERS



**MODU-SYSTEM
FOR PLASTIC
HEAVY DUTY CHAINS**

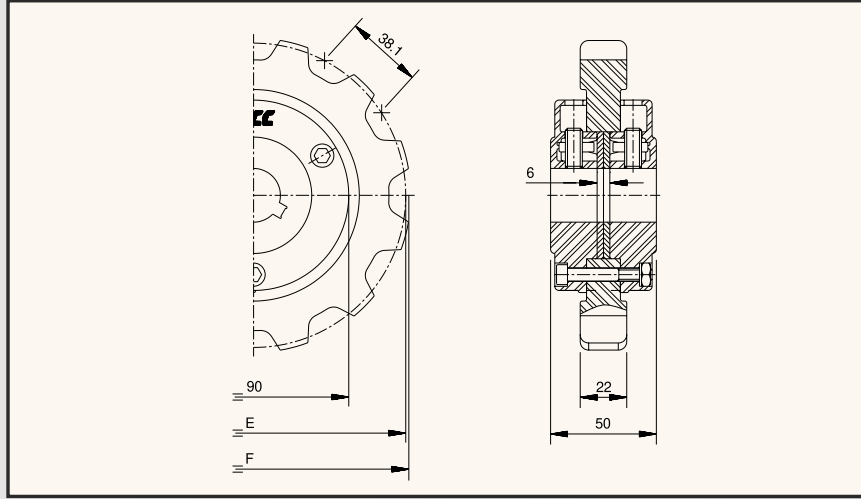

MATERIAL

page 159



14, 18, 19, 22
24, 25, 28, 29

Sprocket type	Code nr.	Nr. of teeth	Bore		Pitch diameter E	Outside diameter F	Hub width A	Weight ≈ kg
			mm	inch				
SPROCKET RINGS								
MR HD 11	753.74.32	11	–	–	135.2	137	–	0.20
MR HD 12	753.74.42	12	–	–	147.2	149	–	0.26
HUB SETS WITH KEYWAY								
MHS OH 25	753.80.01	–	25	–	–	–	50	0.37
MHS OH 30	753.80.02	–	30	–	–	–	50	0.35
MHS OH 35	753.80.03	–	35	–	–	–	50	0.33
MHS OH 40	753.80.04	–	40	–	–	–	50	0.26
HUB SETS WITHOUT KEYWAY								
MHI OH 25	753.80.26	–	25	–	–	–	50	0.23
MHI OH 30	753.80.27	–	30	–	–	–	50	0.22
MHI OH 35	753.80.28	–	35	–	–	–	50	0.22
MHI OH 40	753.80.29	–	40	–	–	–	50	0.22

All combinations of sprocket rings and hub sets within the table are possible.

Create your modu-sprocket from a sprocket ring and a hub set with keyway. Take a hub set without keyway with a sprocket ring for your modu-idler.

CLASSIC SPROCKETS AND IDLERS

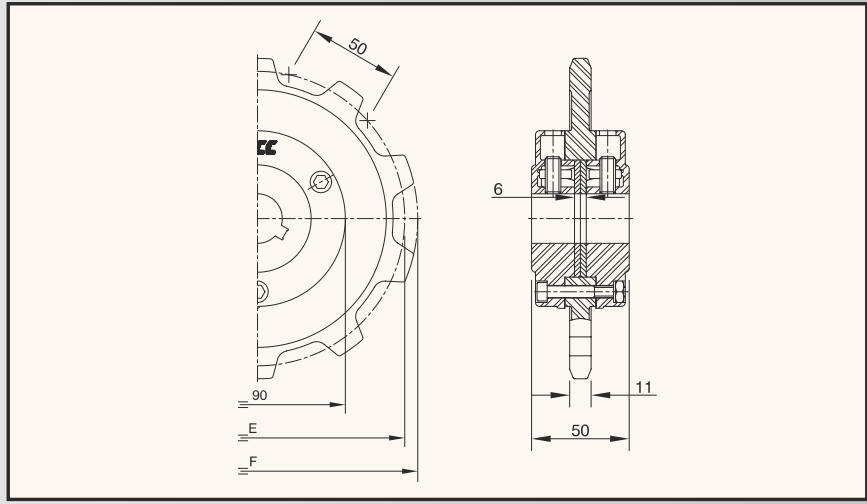

MATERIAL
page 159

page 31, 32, 33

Sprocket type	Code nr.	Nr. of teeth	Bore		Pitch diameter E	Outside diameter F	Hub width A	Weight ≈ kg
			mm	inch				
SPROCKET RINGS								
MR PR/T 10	753.71.22	10	–	–	161.8	165	–	0.15
MR PR/T 12	753.71.42	12	–	–	193.2	196	–	0.22
MR PR/T 14	753.71.62	14	–	–	224.7	227	–	0.31
HUB SETS WITH KEYWAY								
MHS OH 25	753.80.01	–	25	–	–	–	50	0.37
MHS OH 30	753.80.02	–	30	–	–	–	50	0.35
MHS OH 35	753.80.03	–	35	–	–	–	50	0.33
MHS OH 40	753.80.04	–	40	–	–	–	50	0.26
HUB SETS WITHOUT KEYWAY								
MHI OH 25	753.80.26	–	25	–	–	–	50	0.23
MHI OH 30	753.80.27	–	30	–	–	–	50	0.22
MHI OH 35	753.80.28	–	35	–	–	–	50	0.22
MHI OH 40	753.80.29	–	40	–	–	–	50	0.22

All combinations of sprocket rings and hub sets within the table are possible.

Create your modu-sprocket from a sprocket ring and a hub set with keyway. Take a hub set without keyway with a sprocket ring for your modu-idler.

CLASSIC SPROCKETS AND IDLERS



**SPROCKETS
FOR 500 BELTS
ROUND BORE**

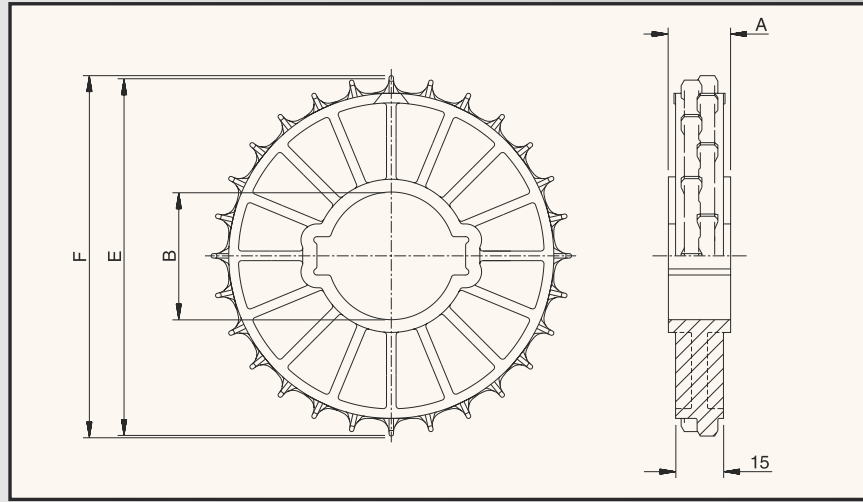

MATERIAL

page 159



page 39

Sprocket type	Code nr.	Nr. of teeth	Bore		Pitch diameter E	Outside diameter F	Hub width A	Weight ≈ kg
			B					
METRIC BORES AND KEYWAYS								
CS 500 16-25	895.26.16	16	25	–	65.2	65.2	20	0.03
CS 500 16-30	895.26.17	16	30	–	65.2	65.2	20	0.03
CS 500 28-25	895.24.16	28	25	–	113.4	113.4	20	0.08
CS 500 28-30	895.24.17	28	30	–	113.4	113.4	20	0.08
CS 500 28-40	895.24.11	28	40	–	113.4	113.4	20	0.08
CS 500 38-40	895.20.11	38	40	–	153.8	153.1	20	0.15
INCH BORES AND KEYWAYS								
CS 500 28-1 ¹ / ₂	895.24.41	28	–	1.5	113.4	113.4	20	0.08



**SPROCKETS
FOR 500 BELTS
SQUARE BORE**

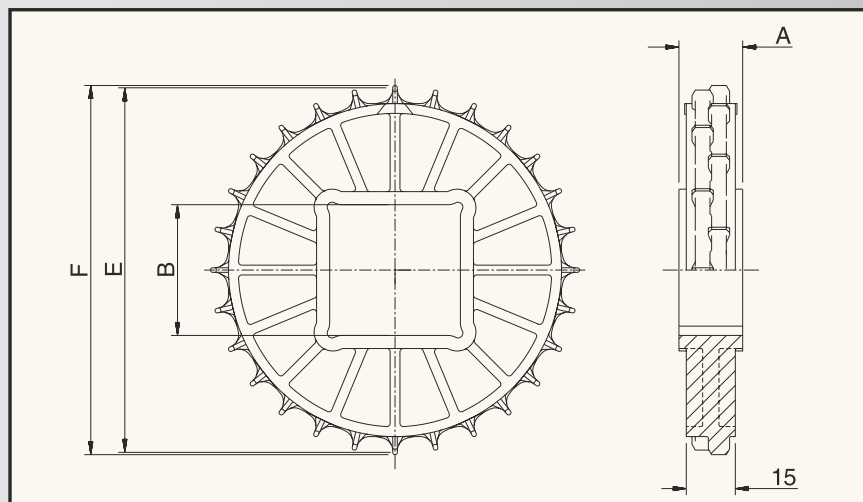

MATERIAL

page 159



page 39

Sprocket type	Code nr.	Nr. of teeth	Bore		Pitch diameter E	Outside diameter F	Hub width A	Weight ≈ kg
			B					
METRIC BORES								
CS 500 28-40x40	895.24.21	28	40x40	–	113.4	113.4	20	0.08
CS 500 28-60x60	895.24.28	28	60x60	–	113.4	113.4	20	0.08

CLASSIC SPROCKETS AND IDLERS

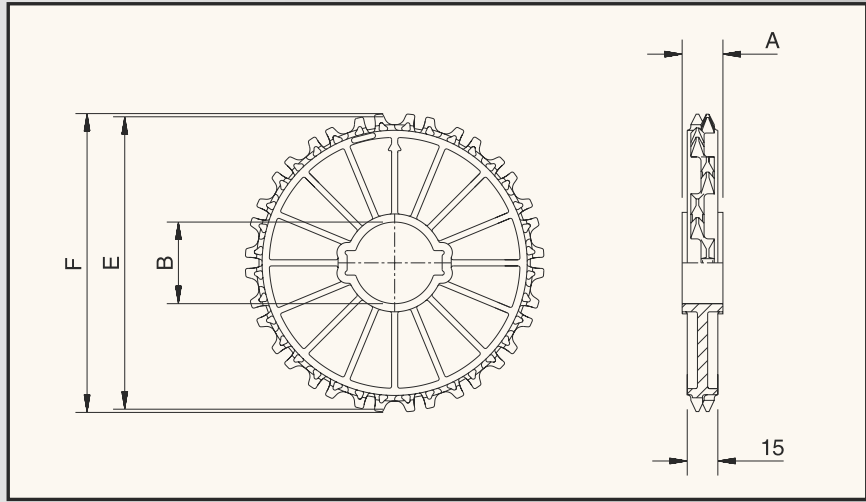

MATERIAL
page 159

page 41-45, 47

Sprocket type	Code nr.	Nr. of teeth	Bore		Pitch diameter E	Outside diameter F	Hub width A	Weight ≈ kg
			B					
			mm	inch	mm	mm	mm	
METRIC BORES AND KEYWAYS								
CS 1000 12-30	895.02.17	12	30	–	98.1	96.5	20	0.05
CS 1000 12-40	895.02.11	12	40	–	98.1	96.5	20	0.05
CS 1000 12-50	895.02.12	12	50	–	98.1	96.5	20	0.05
CS 1000 18-30	895.08.17	18	30	–	146.3	145.9	20	0.11
CS 1000 18-35	895.08.10	18	35	–	146.3	145.9	20	0.11
CS 1000 18-40	895.08.11	18	40	–	146.3	145.9	20	0.11
CS 1000 18-45	895.08.15	18	45	–	146.3	145.9	20	0.11
CS 1000 18-50	895.08.12	18	50	–	146.3	145.9	20	0.11
CS 1000 18-65	895.08.13	18	65	–	146.3	145.9	30	0.11
CS 1000 20-35	895.09.10	20	35	–	162.4	161.7	20	0.14
CS 1000 20-40	895.09.11	20	40	–	162.4	161.7	20	0.14
CS 1000 20-50	895.09.12	20	50	–	162.4	161.7	20	0.14
INCH BORES AND KEYWAYS								
CS 1000 12-1	895.02.46	12	–	1.0	98.1	96.5	20	0.05
CS 1000 18-1	895.08.46	18	–	1.0	146.3	145.9	20	0.11
CS 1000 18-1½	895.08.41	18	–	1.5	146.3	145.9	20	0.11
CS 1000 18-2	895.08.42	18	–	2.0	146.3	145.9	20	0.11
CS 1000 20-1	895.09.46	20	–	1.0	162.4	161.7	20	0.14
CS 1000 20-1½	895.09.41	20	–	1.5	162.4	161.7	20	0.14

For humid, hot applications like pasteurizing, special sprockets are available.

CLASSIC SPROCKETS AND IDLERS



**SPROCKETS
FOR 1000 BELTS
SQUARE BORE**

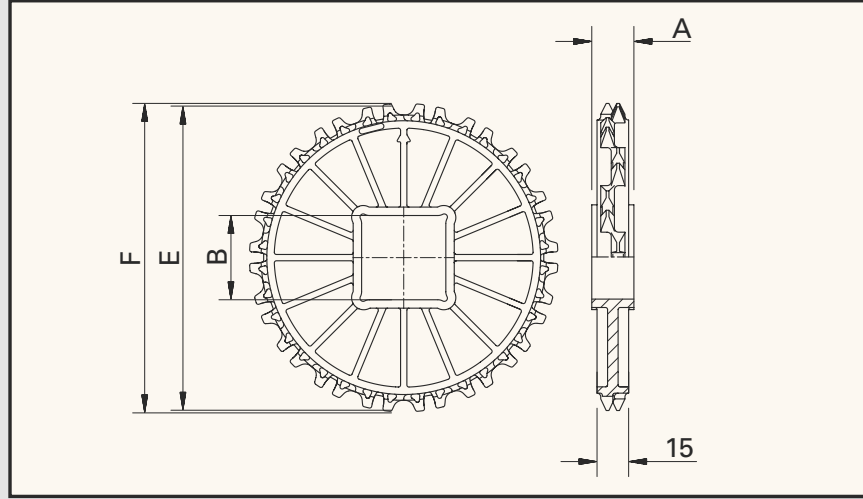

MATERIAL

page 159



page 41-45, 47

Sprocket type	Code nr.	Nr. of teeth	Bore		Pitch diameter E	Outside diameter F	Hub width A	Weight ≈ kg
			B					
			mm	inch	mm	mm	mm	
METRIC BORES								
CS 1000 12-40x40	895.02.21	12	40x40	–	98.1	96.5	20	0.05
CS 1000 18-40x40	895.08.21	18	40x40	–	146.3	145.9	20	0.11
CS 1000 18-60x60	895.08.28	18	60x60	–	146.3	145.9	30	0.11
CS 1000 18-65x65	895.08.23	18	65x65	–	146.3	145.9	30	0.11
CS 1000 20-40x40	895.09.21	20	40x40	–	162.4	161.7	20	0.14
CS 1000 20-60x60	895.09.28	20	60x60	–	162.4	161.7	30	0.14
CS 1000 20-65x65	895.09.23	20	65x65	–	162.4	161.7	30	0.14
INCH BORES								
CS 1000 12-1½x1½	895.02.51	12	–	1.5x1.5	98.1	96.5	20	0.05
CS 1000 18-1½x1½	895.08.51	18	–	1.5x1.5	146.3	145.9	20	0.11
CS 1000 20-1½x1½	895.09.51	20	–	1.5x1.5	162.4	161.7	20	0.14

For humid, hot applications like pasteurizing, special sprockets are available.

CLASSIC SPROCKETS AND IDLERS

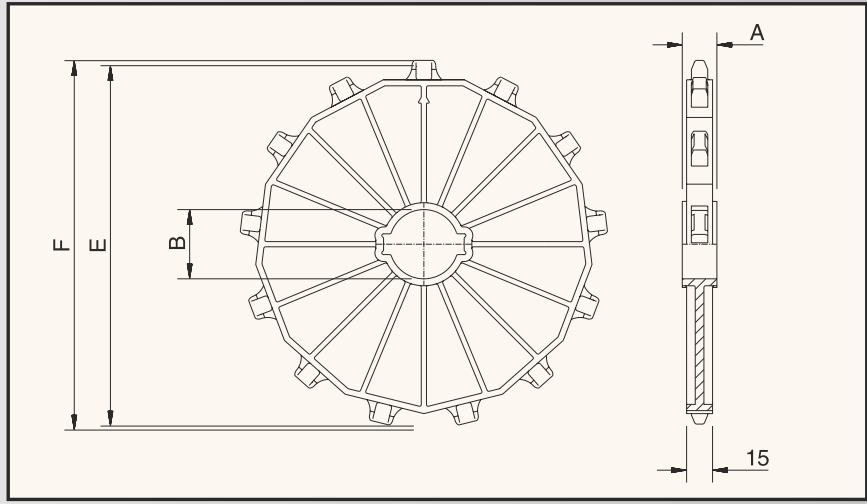

MATERIAL
page 159

page 57, 58, 59

Sprocket type	Code nr.	Nr. of teeth	Bore		Pitch diameter E	Outside diameter F	Hub width A	Weight ≈ kg
			B					
			mm	inch	mm	mm	mm	
METRIC BORES AND KEYWAYS								
CS 2000 10-65	895.10.13	10	65	–	164.4	163.1	30	0.15
CS 2000 12-40	895.12.11	12	40	–	196.3	196.3	20	0.21
CS 2000 12-65	895.12.13	12	65	–	196.3	196.3	30	0.21
CS 2000 13-40	895.13.11	13	40	–	212.3	209.0	20	0.22
CS 2000 13-65	895.13.13	13	65	–	212.3	209.0	30	0.22
CS 2000 13-90	895.13.14	13	90	–	212.3	209.0	45	0.25
CS 2000 16-65	895.16.13	16	65	–	260.4	262.0	30	0.35
CS 2000 16-90	895.16.14	16	90	–	260.4	262.0	45	0.35

For humid, hot applications like pasteurizing, special sprockets are available, see page 152.

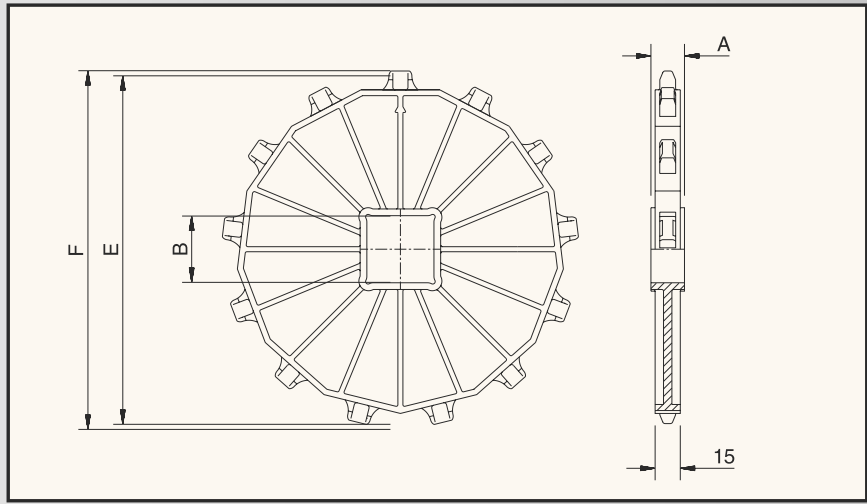

MATERIAL
page 159

page 57, 58, 59

Sprocket type	Code nr.	Nr. of teeth	Bore		Pitch diameter E	Outside diameter F	Hub width A	Weight ≈ kg
			B					
			mm	inch	mm	mm	mm	
METRIC BORES								
CS 2000 12-40x40	895.12.21	12	40x40	–	196.3	196.3	20	0.21
CS 2000 12-60x60	895.12.28	12	60x60	–	196.3	196.3	30	0.21
CS 2000 12-65x65	895.12.23	12	65x65	–	196.3	196.3	30	0.21
CS 2000 13-60x60	895.13.28	13	60x60	–	212.3	209.0	30	0.22
CS 2000 13-65x65	895.13.23	13	65x65	–	212.3	209.0	30	0.23
CS 2000 16-60x60	895.16.28	16	60x60	–	260.4	262.0	30	0.35
CS 2000 16-65x65	895.16.23	16	65x65	–	260.4	262.0	30	0.35
CS 2000 16-90x90	895.16.24	16	90x90	–	260.4	262.0	45	0.36
CS 2000 16-120x120	895.16.29	16	120x120	–	260.4	262.0	45	0.36

For humid, hot applications like pasteurizing, special sprockets are available, see page 152.

CLASSIC SPROCKETS AND IDLERS



SPROCKETS FOR HUMID APPLICATIONS FOR 2000 BELTS ROUND BORE

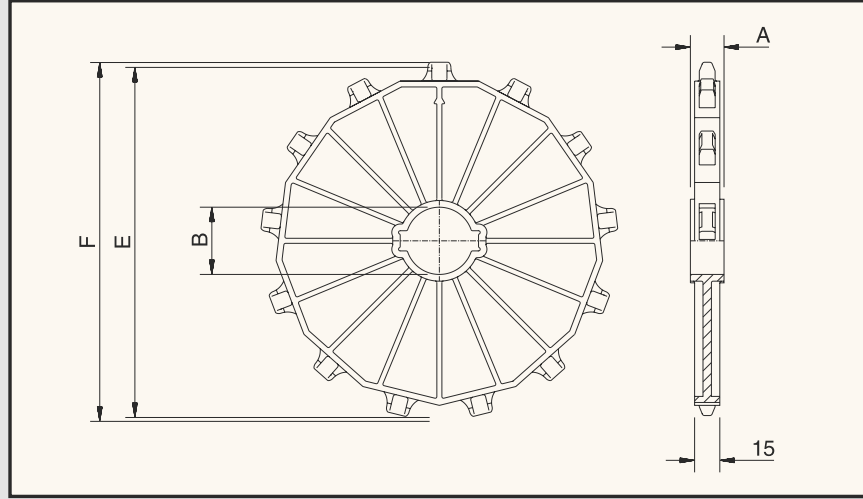

MATERIAL

page 159



page 57, 58, 59

Sprocket type	Code nr.	Nr. of teeth	Bore		Pitch diameter E	Outside diameter F	Hub width A	Weight ≈ kg
			B					
			mm	inch	mm	mm	mm	
METRIC BORES AND KEYWAYS								
CS 2000 10-40 POM	893.10.11	10	40	–	164.4	163.1	20	0.18
CS 2000 10-50 POM	893.10.12	10	50	–	164.4	163.1	30	0.18
CS 2000 12-40 POM	893.12.11	12	40	–	196.3	196.3	20	0.27
CS 2000 13-65 POM	893.13.13	13	65	–	212.3	209.0	30	0.30
CS 2000 13-90 POM	893.13.14	13	90	–	212.2	209.0	45	0.33
CS 2000 16-90 POM	893.16.14	16	90	–	260.4	262.0	45	0.47
INCH BORES AND KEYWAYS								
CS 2000 16-2½ POM	893.16.43	16	–	2.5	260.4	262.0	30	0.43

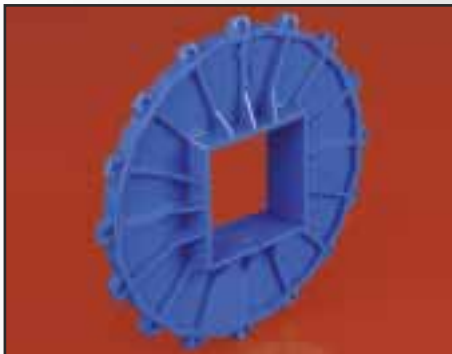

SPROCKETS FOR HUMID APPLICATIONS FOR 2000 BELTS SQUARE BORE

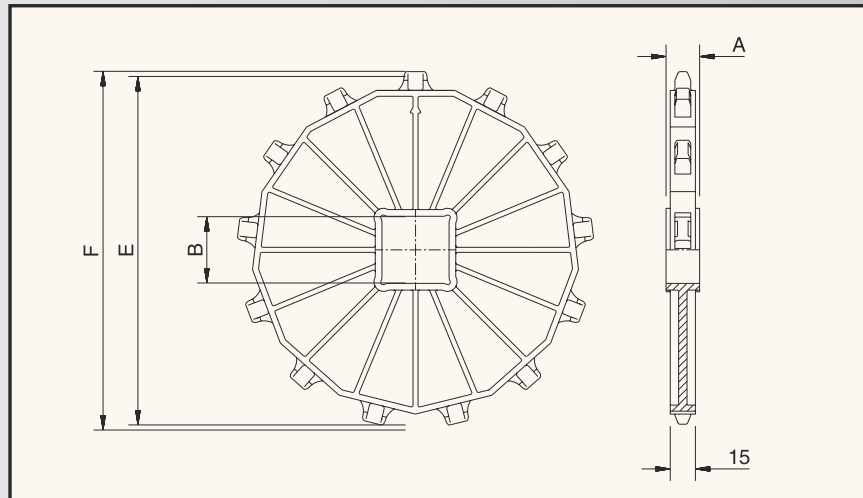

MATERIAL

page 159



page 57, 58, 59

Sprocket type	Code nr.	Nr. of teeth	Bore		Pitch diameter E	Outside diameter F	Hub width A	Weight ≈ kg
			B					
			mm	inch	mm	mm	mm	
METRIC BORES								
CS 2000 10-40x40 POM	893.10.21	10	40x40	–	164.4	163.1	30	0.21
CS 2000 10-60x60 POM	893.10.28	10	60x60	–	164.4	163.1	30	0.19
CS 2000 10-65x65 POM	893.10.23	10	65x65	–	164.4	163.1	30	0.18
CS 2000 12-40x40 POM	893.12.21	12	40x40	–	196.3	196.3	20	0.26
CS 2000 12-60x60 POM	893.12.28	12	60x60	–	196.3	196.3	30	0.27
CS 2000 12-65x65 POM	893.12.23	12	65x65	–	196.3	196.3	30	0.26
CS 2000 13-40x40 POM	893.13.21	13	40x40	–	212.3	209.0	30	0.33
CS 2000 13-65x65 POM	893.13.23	13	65x65	–	212.3	209.0	30	0.30
CS 2000 13-90x90 POM	893.13.24	13	90x90	–	212.3	209.0	30	0.27
CS 2000 16-65x65 POM	893.16.23	16	65x65	–	260.4	262.0	45	0.46
CS 2000 16-90x90 POM	893.16.24	16	90x90	–	260.4	262.0	45	0.46
CS 2000 16-120x120 POM	893.16.29	16	120x120	–	260.4	262.0	45	0.42

CLASSIC SPROCKETS AND IDLERS

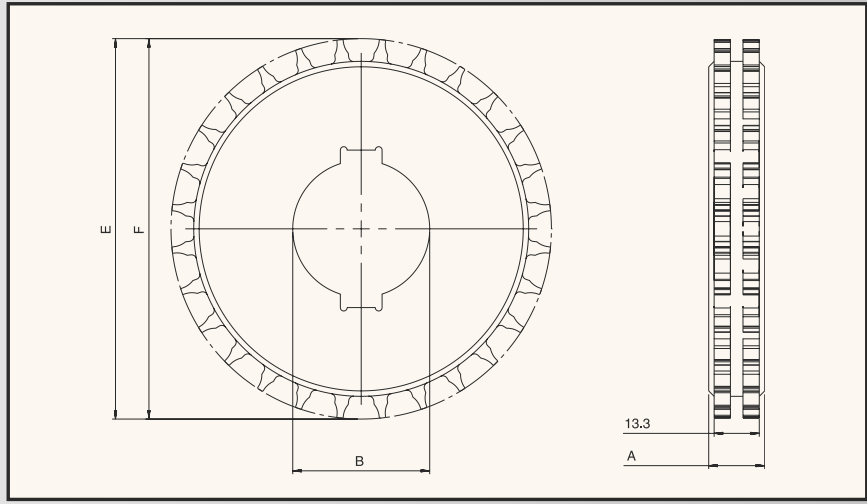

MATERIAL
page 159

page 63

Sprocket type	Code nr.	Nr. of teeth	Bore		Pitch diameter E	Outside diameter F	Hub width A	Weight ≈ kg
			B					
			mm	inch	mm	mm	mm	
METRIC BORES AND KEYWAYS								
CS 505 28-25	894.25.16	28	25	–	113.4	113.4	16.5	0.14
CS 505 28-30	894.25.17	28	30	–	113.4	113.4	16.5	0.14
CS 505 28-35	894.25.10	28	35	–	113.4	113.4	16.5	0.14
CS 505 28-40	894.25.11	28	40	–	113.4	113.4	16.5	0.14
INCH BORES AND KEYWAYS								
CS 505 28-1	894.25.46	28	–	1.0	113.4	113.4	16.5	0.14
CS 505 28-1½	894.25.41	28	–	1.5	113.4	113.4	16.5	0.14

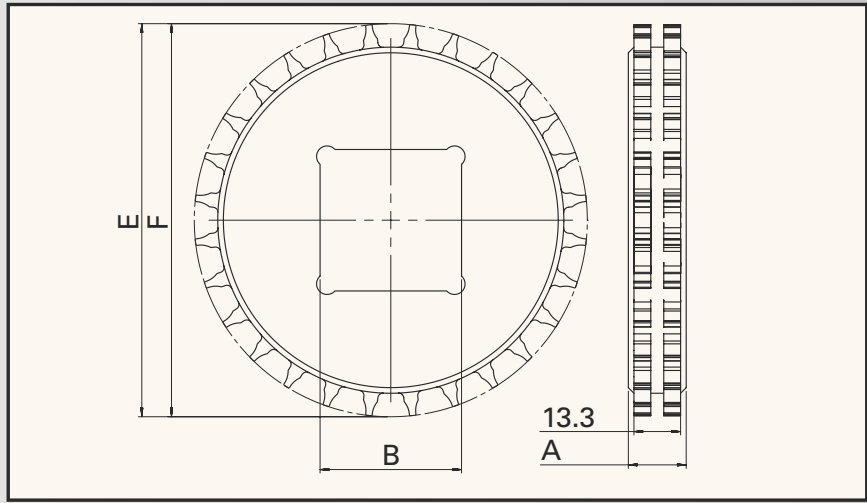

MATERIAL
page 159

page 63

Sprocket type	Code nr.	Nr. of teeth	Bore		Pitch diameter E	Outside diameter F	Hub width A	Weight ≈ kg
			B					
			mm	inch	mm	mm	mm	
METRIC BORES								
CS 505 28-25x25	894.25.26	28	25x25	–	113.4	113.4	16.5	0.14
CS 505 28-30x30	894.25.27	28	30x30	–	113.4	113.4	16.5	0.14
CS 505 28-35x35	894.25.20	28	35x35	–	113.4	113.4	16.5	0.14
CS 505 28-40x40	894.25.21	28	40x40	–	113.4	113.4	16.5	0.14
INCH BORES								
CS 505 28-1x1	894.25.56	28	–	1.0x1.0	113.4	113.4	16.5	0.14
CS 505 28-1½x1½	894.25.51	28	–	1.5x1.5	113.4	113.4	16.5	0.14

CLASSIC SPROCKETS AND IDLERS

MATERIAL

page 159

page 64



**SPROCKETS FOR
1255 BELTS
ROUND BORE**

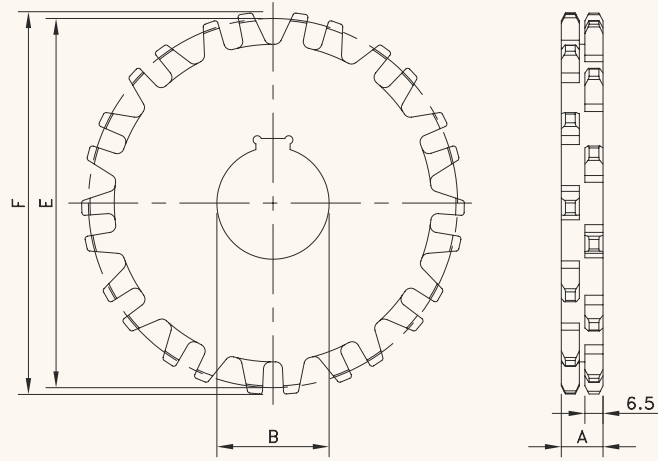

Sprocket type	Code nr.	Nr. of teeth	Bore		Pitch diameter E	Outside diameter F	Hub width A	Weight ≈ kg
			B	mm				
METRIC BORES AND KEYWAYS								
CS 1255 8-30	894.67.37	8	30	–	83.0	85.4	16.5	0.2
CS 1255 10-30	894.59.37	10	30	–	102.8	106.6	16.5	0.2
CS 1255 13-40	894.63.31	13	40	–	132.7	137.5	16.5	0.4
CS 1255 15-40	894.61.31	15	40	–	152.7	158.1	16.5	0.5
CS 1255 16-40	894.65.31	16	40	–	162.8	168.3	16.5	0.6



**SPROCKETS FOR
1255 BELTS
SQUARE BORE**

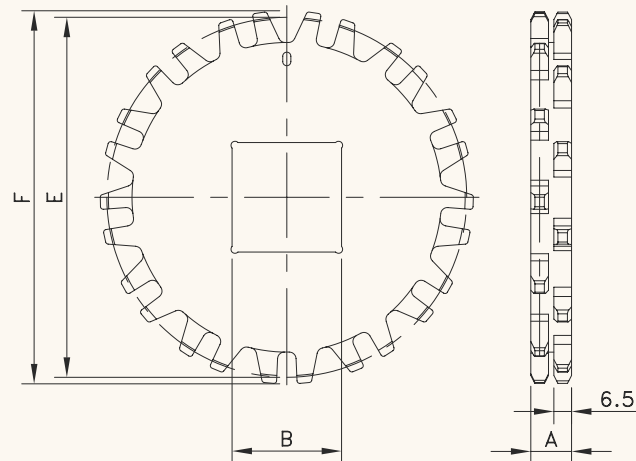

Sprocket type	Code nr.	Nr. of teeth	Bore		Pitch diameter E	Outside diameter F	Hub width A	Weight ≈ kg
			B	mm				
METRIC BORES								
CS 1255 8-25x25	894.67.46	8	25x25	–	83.0	85.4	16.5	0.2
CS 1255 10-40x40	894.59.41	10	40x40	–	102.8	106.6	16.5	0.2
CS 1255 13-40x40	894.63.41	13	40x40	–	132.7	137.5	16.5	0.4
CS 1255 15-40x40	894.61.41	15	40x40	–	152.7	158.1	16.5	0.5
CS 1255 16-40x40	894.65.41	16	40x40	–	162.8	168.3	16.5	0.6

MATERIAL

page 159

page 64

CLASSIC SPROCKETS AND IDLERS



**SPROCKETS FOR
7956 BELTS
ROUND BORE**

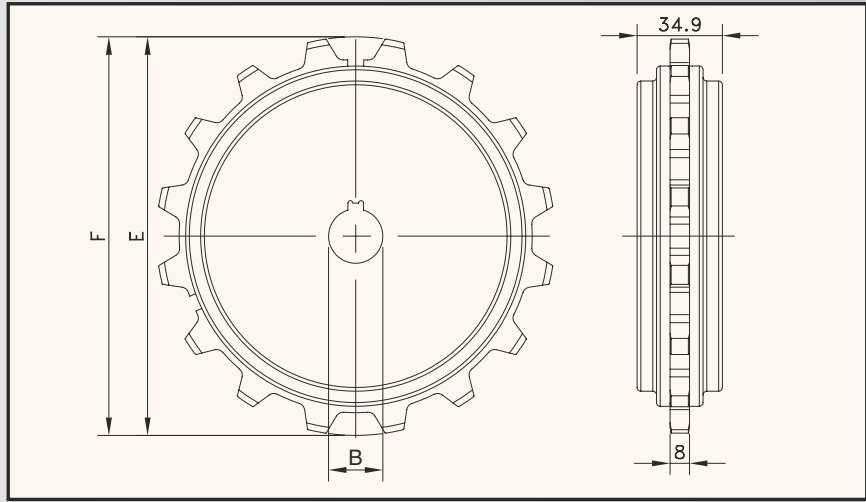

MATERIAL
page 159

page 65

Sprocket type	Code nr.	Nr. of teeth	Bore		Pitch diameter E mm	Outside diameter F mm	Hub width A mm	Weight ≈ kg
			B mm	inch				
METRIC BORE AND KEYWAY								
CS 7956 16-20	I7956613482	16	20	-	162.7	163.2	34.9	0.9

Other bore sizes available on request.

CONVEYOR COMPONENTS

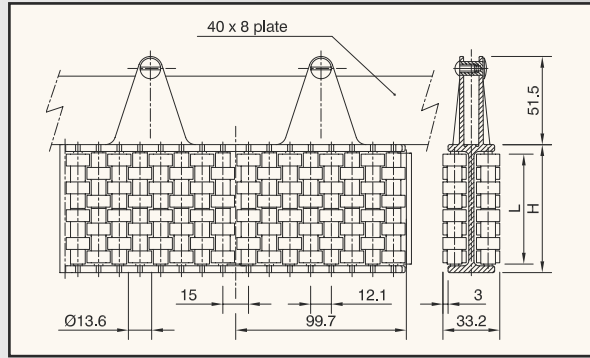

GUIDE RAIL SYSTEM SEPARATING ROLLER GUIDE

Type	Height H	Roller length L	Code nr.
	mm	mm	
STANDARD MODULE			
Double module	74.0	64.4	S0557610612
Single module	42.3	32.2	S0557610622N

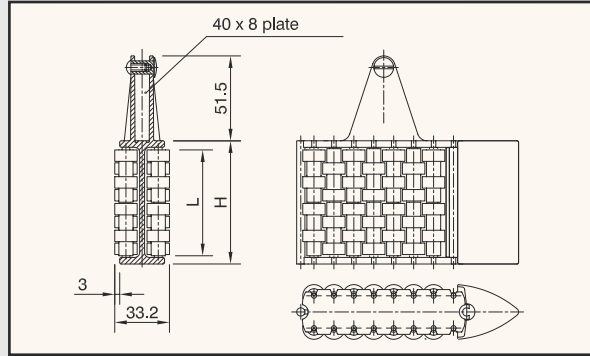

GUIDE RAIL SYSTEM SEPARATING ROLLER GUIDE

Type	Height H	Roller length L	Code nr.
	mm	mm	
DIVIDER MODULE			
Double module	74.0	64.4	S0570610632
Single module	42.3	32.2	S0570610622N

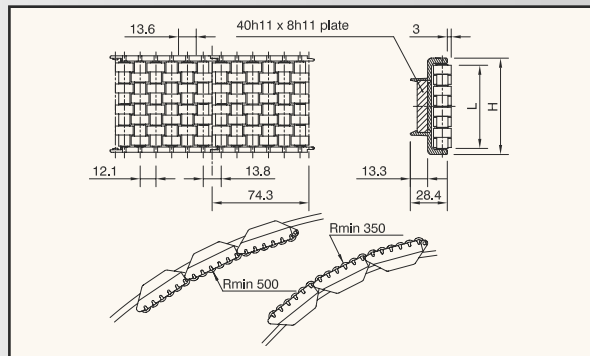
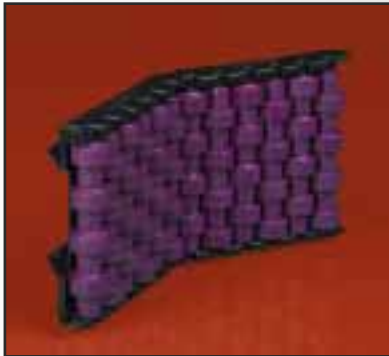

GUIDE RAIL SYSTEM SNAP-ON ROLLER SIDE GUIDE

Type	Height H	Roller length L	Code nr.
	mm	mm	
SNAP-ON ROLLER SIDE GUIDE			
Double module	74.0	64.4	S0580610652
Single module	42.3	32.2	S0580610642

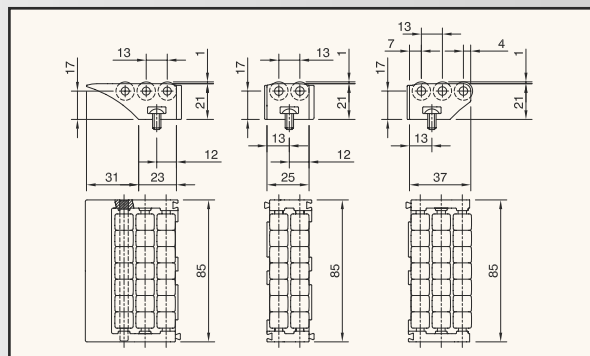

MODULAR TRANSFER PLATE WITH ROLLERS

Modules are supplied as separate items

Type	Code nr.
Center module	S0568610672
Endmodule with flight	S0567610662
Endmodule without flight	S0569610682

CONVEYOR COMPONENTS

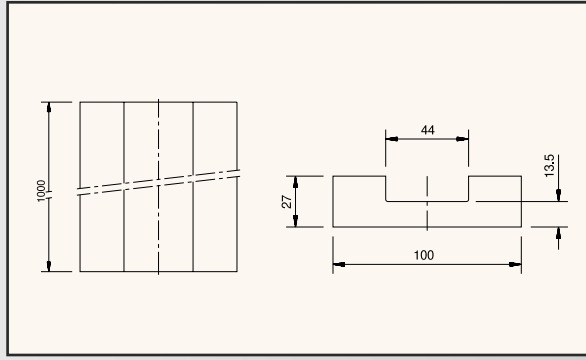

STRAIGHT SECTION UPPER PART

For chain types: 10 S 31 M, 10 S 31 (S), 18 S 31 M, 45 S 31 M, 60 S 31 (S), 60 S 31 (S)M, 60 S 31 R, 10 M 31 M, 45 M 31 M, 60 M 31 (S)M, 60 M 31 RM, RHM(D) 325, SH(D) 325

Basic width mm	Height mm	Length mm	Code nr.
UPPER PART			
100	27	1000	759.61.41

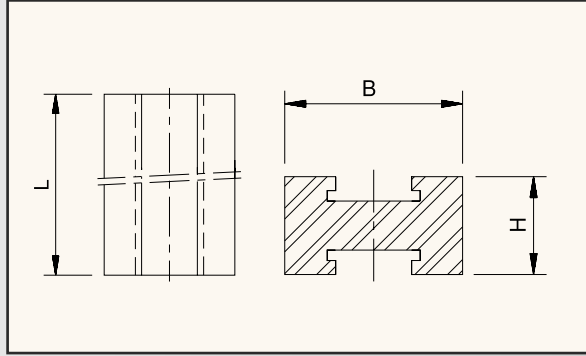

STRAIGHT SECTIONS COMBINED UPPER/RETURN PART, SINGLE TRACK

A wide range of non-standard sections can be supplied

For chain type	Basic width B mm	Height H mm	Length L mm	Code nr.
COMBINED UPPER AND RETURN PART				
SRH 325	100	55	2000	755.55.11
RH(D) 325	100	55	2000	755.55.21
RH(D) 450	129	55	2000	755.55.41

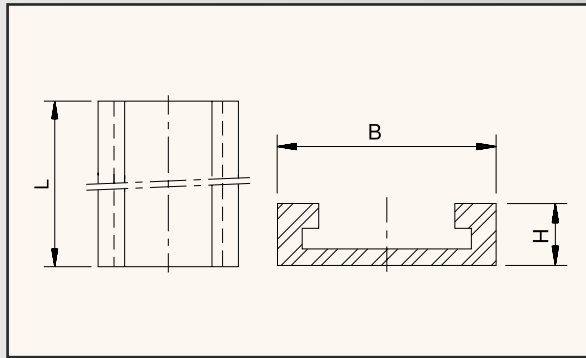

STRAIGHT SECTIONS SEPARATE UPPER/RETURN PART, SINGLE TRACK

For chain type	Basic width B mm	Height H mm	Length L mm	Code nr.
SEPARATE UPPER AND RETURN PART				
HDF 450	125	32	2000	755.66.01
HDF 750	200	32	2000	755.66.11
HDF 1000	265	32	2000	755.66.21
HDF 1200	315	32	2000	755.66.31
PRT 200	90	25	2000	755.65.51

2 parts are required to make 1 complete section

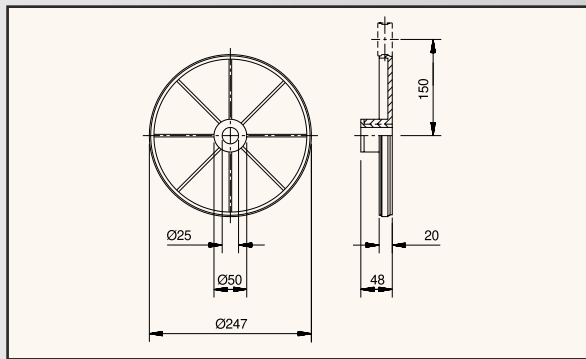

CORNER DISC

For plastic multiflex chains
PR 1700
See page 33

Bore mm	Code nr.
25	757.01.55

MATERIALS

Product	Material slat/belt	Material pin
STEEL SLATBAND CHAINS		
10-series	AISI 430 (Werkstoff-Nr. 1.4016) special 17% chrome stainless steel for improved corrosion resistance, wearlife and strength	AISI 431 (Werkstoff-Nr. 1.4057)
18-series	AISI 304 (Werkstoff-Nr. 1.4301) 18/8 chrome-nickel stainless steel for maximum corrosion resistance, long wearlife and high strength	AISI 304 (Werkstoff-Nr. 1.4301)
45-series	AISI 4140 (Werkstoff-Nr. 1.7225) through hardened carbon steel for high strength and abrasion resistance; colour: black	AISI 1045 (Werkstoff-Nr. 1.0503)
60-series Star	Special chrome-nickel stainless steel for excellent sliding properties, improved corrosion resistance, long wearlife and high strength	AISI 431 (Werkstoff-Nr. 1.4057)
Rubber top	Special elastomere with a hardness of 70 Shore A	
PLASTIC SLATBAND CHAINS		
XL-series	Internally lubricated, extra low friction polyacetal for improved wearlife and high strength. Colour: light brown	AISI 431 (Werkstoff-Nr. 1.4057) Case conveyor chains: AISI 301 (Werkstoff-Nr. 1.4310)
XS-series	State-of-the-art polyacetal with high PV limits for longer life and continuous low friction; colour: aubergine	AISI 431 (Werkstoff-Nr. 1.4057)
NC-series	Wear resistant, special polyacetal Colour: white	AISI 431 (Werkstoff-Nr. 1.4057) Case conveyor chains: AISI 301 (Werkstoff-Nr. 1.4310)
CRS-series	Polyester for improved chemical resistance. Colour: white	AISI 304 (Werkstoff-Nr. 1.4301)
LBP-series	Wear resistant, extra low friction XLA-polyacetal with special selflubricating additives. Colour: anthracite Rollers are made of special wear resistant and sound absorbing plastic; colour: aubergine. Roller shafts: stainless steel AISI 304 (Werkstoff-Nr. 1.4301)	AISI 431 (Werkstoff-Nr. 1.4057)
SG-series	Wear resistant Polybutylenterephthalat (PBT). Colour: anthracite. Rubber top material: special elastomere with a hardness of 70 Shore A. Colour: aubergine	AISI 431 (Werkstoff-Nr. 1.4057)
AS-series	Polyacetal with improved electrical conductive properties, reducing the build-up of static electricity. Colour: black	AISI 431 (Werkstoff-Nr. 1.4057)
PLASTIC MODULAR CONVEYOR BELTS		
XLG	Internally lubricated, extra low friction polyacetal for improved wearlife and high strength; FDA approved. Colour: green-blue	Polypropylene 505: special reinforced plastic RR narrow 1000, 84, 1005, 1255 and 7956 belts: polybutylenterephthalat (PBT)
XP	Wear resistant polypropylene with excellent long term heat stability – up to 104°C – and a very good chemical resistance; FDA approved. Colour: light green.	Polypropylene
XP SuperGrip belts	Wear resistant polypropylene with a very good chemical resistance. Rubber top: special elastomere, hardness 40 Shore A. Colour: light green and black	Polybutylenterephthalat (PBT)
PG SuperGrip belts	Wear resistant polybutylenterephthalat (PBT) with a high strength. Rubber top: special elastomere, hardness 50 Shore A. Colour: green-blue and black	Polypropylene
AS	Polyacetal with improved electrical conductive properties, reducing the build-up of static electricity. Colour: black	Polypropylene
XLA	Internally lubricated, extra low friction polyacetal for improved wearlife and high strength. Colour: anthracite	Polybutylenterephthalat (PBT)
YP	Wear resistant polypropylene with excellent long term heat stability – up to 104°C – and a very good chemical resistance. Colour: yellow	Polypropylene
YPR	Wear resistant reinforced polypropylene with excellent long term heat stability – up to 104°C – and a very good chemical resistance. Colour: yellow	Reinforced polypropylene
XS	State-of-the-art polyacetal with high PV limits for longer life and continuous low friction; colour: aubergine	Polypropylene
Fingerplates	XLG-polyacetal. Colour: green-blue	
DTS-C	Super tough reinforced polyamide, wear and abrasion resistant, extra high strength. Colour: black	
MC 2500 mounting block	MCC 1001; high grade mix of UHMWPE. Colour: black	
Fingers 2500	Reinforced BPR-Polypropylene. Colour: green-blue	
Profile fingerplates	Stainless steel AISI 304 (Werkstoff Nr. 1.4301)	

MATERIALS

Part	Material
CURVES	
Upper part of Combi-A and CIP-curves	MCC 1200, ultra high molecular weight polyethylene, for optimum wear and abrasion resistance with a molecular weight exceeding 6 million g/mol. Colour: aubergine
Upper part of Combi-G curves	MCC 2000, ultra high molecular weight polyethylene, with specially integrated ceramic additives, for superior abrasion resistance with a molecular weight exceeding 6 million g/mol. Colour: green-yellow
Upper part of Combi-S curves	MCC 3500, special polyamide for optimum wear resistance in dry running lines where plastic chains run at high speeds. Colour: sulphite grey
Upper part of Combi-L curves	MCC 3000, ultra high molecular weight polyethylene, for noise reduction and high PV limits with a molecular weight exceeding 6 million g/mol. Colour: light blue
All return parts	MCC 1001, high grade mix of ultra high molecular weight polyethylene, for good wear and abrasion resistance with a molecular weight exceeding 4 million g/mol. Colour: black
Cover plates	Stainless steel AISI 430 (Werkstoff Nr. 1.4016)
Screws	Stainless steel
Inserts (optional)	Brass
Return guide shoe	MCC 1000, ultra high molecular weight polyethylene, for good wear and abrasion resistance with a molecular weight exceeding 4 million g/mol. Colour: black
Tubes in CIP-curves	Stainless steel AISI 303 (Werkstoff Nr. 1.4305)
Nozzles in CIP-curves	Stainless steel AISI 303 (Werkstoff Nr. 1.4305)
Tab curves	MCC 1002, ultra high molecular weight polyethylene, for good wear and abrasion resistance with a molecular weight exceeding 4 million g/mol
- inserts (optional)	Brass

Product	Material
SPLIT SPROCKETS AND IDLERS	
Sprockets and idlers for chains - bolts - inserts - fitted pins	Super tough polyamide, wear and abrasion resistant Stainless steel AISI 304 (Werkstoff Nr. 1.4301) Brass AISI 431 (Werkstoff-Nr. 1.4057)
Sprockets for CC-chains and idlers for CC-1400 chains - hub - bolts, nuts and washers	Super tough polyamide, wear and abrasion resistant Carbon steel with black finish or stainless steel Stainless steel
Idler drums - bolts - inserts - fitted pins	Super tough polyamide, wear and abrasion resistant Stainless steel AISI 304 (Werkstoff Nr. 1.4301) Brass AISI 431 (Werkstoff-Nr. 1.4057)
Sprockets for belts, SS types - bolts and nuts	Super tough, wear and abrasion resistant special plastic Stainless steel AISI 304 (Werkstoff Nr. 1.4301)
Sprockets for belts, SSW types and for 2500-series - bolts and nuts	Super tough (reinforced) polyamide, wear and abrasion resistant, extra high strength Stainless steel AISI 304 (Werkstoff Nr. 1.4301)
Sprockets for belts, POM types - bolts and nuts	Wear resistant polyacetal. Colour: blue Stainless steel AISI 304 (Werkstoff Nr. 1.4301)
Sprockets for chainbelts - bolts and nuts - inserts - fitted pins	Super tough polyamide, wear and abrasion resistant Stainless steel AISI 304 (Werkstoff Nr. 1.4301) Brass AISI 431 (Werkstoff Nr. 1.4057)
CLASSIC SPROCKETS AND IDLERS	
Sprocket ring (for modu-sprocket and modu-idler)	Super tough polyamide, wear and abrasion resistant
Hub set with keyway - reinforcement plates - bolts, self-locking nuts and grub screws	Special polyacetal with finish bore and keyway. Colour: black Stainless steel AISI 430 (Werkstoff Nr. 1.4016) Stainless steel AISI 304 (Werkstoff Nr. 1.4301)
Hub set without keyway - bolts and self-locking nuts	Low friction polyacetal with finish bore, without keyway. Colour: light brown Stainless steel AISI 304 (Werkstoff Nr. 1.4301)
Guide rings - screws	Super tough polyamide, wear and abrasion resistant Stainless steel AISI 304 (Werkstoff Nr. 1.4301)
Idler drums (solid type)	Special low friction polyamide
Idler drums (discs and spacers): - bolts, self-locking nuts and washers	Special low friction polyamide Zinc plated steel
Sprockets for belts	Super tough polyamide, wear and abrasion resistant
Sprockets for belts; POM types	Wear resistant polyacetal. Colour: blue

Product	Material
COMPONENTS	
Separating roller guide	Rollers: special wear resistant and sound absorbing plastic; link and shaft: polyacetal; bush: nickel-plated brass; screw: stainless steel
Snap-on roller side guide	Rollers: special wear resistant and sound absorbing plastic; link and shaft: polyacetal
Modular transfer plate with rollers	Rollers: special wear resistant and sound absorbing plastic; link: polyacetal; shaft: stainless steel (AISI 304); screw: stainless steel
Straight sections	MCC 1000, ultra high molecular weight polyethylene, for good wear and abrasion resistance with a molecular weight exceeding 4 million g/mol. Colour: black
Corner disc - hub	Glass fibre reinforced polyamide Low friction polyacetal

Code nr.	page	Code nr.	page	Code nr.	page	Code nr.	page
604.08.xx	100	752.85.09	21	776.55.xx	108	877.03.xx	51
604.14.xx	101	752.87.09	23	776.56.xx	108	877.04.xx	51
604.15.xx	102	752.88.xx	24	780.11.xx	27	877.05.xx	49
614.01.xx	103	752.89.xx	25	780.21.xx	29	877.06.xx	49
614.02.xx	104	752.92.04	36	780.31.xx	28	877.50.xx	53
614.06.xx	105	752.95.04	36	781.12.xx	17	877.51.xx	53
614.08.xx	106	753.61.xx	113	781.17.31	17	877.52.xx	54
614.09.xx	107	753.62.xx	112	781.22.xx	17	877.53.xx	54
704.05.xx	76	753.63.xx	118	781.30.31	17	877.64.xx	53
704.06.xx	77	753.64.xx	115	785.43.xx	99	877.65.xx	54
704.07.xx	78	753.65.xx	113	785.45.xx	98	877.66.xx	53
704.08.xx	79	753.66.xx	112	800.00.01	63	877.67.xx	54
704.09.xx	80	753.67.xx	111	800.00.10	64	880.60.xx	59
704.10.xx	80	753.70.xx	145	801.55.xx	73	880.90.xx	59
704.11.xx	81	753.71.xx	147	801.57.01	73	893.10.xx	152
704.12.xx	81	753.72.xx	144	804.02.xx	109	893.12.xx	152
704.14.xx	82	753.73.xx	141, 143	805.02.xx	109	893.13.xx	152
704.15.xx	83	753.74.xx	146	814.10.xx	43	893.16.xx	152
704.28.xx	87	753.78.xx	129	814.12.xx	71	893.73.24	134
704.29.xx	88	753.80.xx	141, 143-147	814.30.xx	42	893.76.xx	134
704.34.xx	95	753.83.xx	129	814.40.xx	41	894.25.xx	153
714.08.xx	84	754.02.xx	142	817.10.xx	43	894.26.xx	135
714.09.xx	85	754.10.xx	114, 116, 119,	817.12.xx	71	894.30.xx	132, 133
714.21.xx	86		124, 125, 128	817.30.xx	42	894.33.xx	132, 133
724.05.xx	89	754.11.xx	114, 117, 119,	817.40.xx	41	894.59.xx	154
724.07.xx	90		124, 125	818.10.xx	43	894.60.xx	137
724.11.xx	90	754.12.xx	114, 116, 117,	818.30.xx	42	894.61.xx	154
724.31.xx	91		119, 124	818.40.xx	41	894.62.xx	137
724.36.xx	92	754.13.xx	116, 117, 125	832.70.xx	61	894.63.xx	154
724.42.xx	93	754.60.xx	122, 123	832.80.xx	61	894.64.xx	137
724.44.xx	94	754.61.xx	121	834.12.79	72	894.65.xx	154
724.45.xx	96	754.62.xx	120	834.72.xx	73	894.66.xx	137
724.46.xx	97	754.63.xx	126	837.12.xx	72	894.67.xx	154
724.47.xx	96	754.65.xx	121	838.10.xx	58	895.02.xx	149, 150
749.11.31	67	754.66.xx	120	838.30.xx	57	895.08.xx	149, 150
749.16.31	67	754.67.xx	127	838.40.xx	57	895.09.xx	149, 150
749.21.31	68	755.55.xx	157	838.90.xx	58	895.10.13	151
749.26.31	68	755.65.51	157	857.40.xx	39	895.12.xx	151
749.41.xx	69	755.66.xx	157	867.30.xx	63	895.13.xx	151
749.81.xx	139	756.32.xx	109	867.40.xx	64	895.16.xx	151
749.82.xx	139	756.34.xx	109	867.54.xx	64	895.20.11	148
749.85.xx	139	756.36.xx	109	871.00.xx	45	895.24.xx	148
749.86.xx	139	756.58.xx	108	871.01.xx	44	895.26.xx	148
750.10.31	13	757.01.55	157	871.02.xx	45	895.54.xx	136
750.42.xx	13	759.61.41	157	871.03.xx	44	899.06.xx	131
750.47.31	13	762.10.31	3	873.07.xx	42	899.08.xx	131
750.56.31	13	762.12.31	3	873.08.xx	42	899.09.xx	131
750.72.xx	14	762.13.xx	3, 4	873.21.09	42	899.14.xx	130
750.92.xx	13	762.43.xx	3	873.27.xx	42	899.97.29	134
751.12.31	15	762.50.xx	3, 5	873.29.xx	42	I7956613482	155
751.32.xx	18	762.53.xx	3, 4	873.32.xx	42	S0557610602N	156
751.42.xx	16	762.54.xx	9	874.04.xx	39	S0557610612	156
751.47.31	16	762.56.77	10	874.05.xx	39	S0567610662	156
751.62.xx	16	762.62.31	3	874.06.xx	39	S0568610672	156
751.82.xx	19	762.69.xx	3	874.07.xx	41	S0569610682	156
752.09.xx	31, 32	762.83.xx	3, 4	874.08.xx	41	S0570610622N	156
752.12.xx	31, 32, 33	767.13.xx	6	874.30.09	41	S0570610632	156
752.15.11	33	767.43.xx	6	874.43.xx	41	S0580610642	156
752.32.xx	36	767.53.xx	6	874.45.xx	41	S0580610652	156
752.35.xx	36	767.54.75	11	874.48.xx	41	614-169-x	138
752.42.04	35	767.56.xx	11	875.00.xx	47	614-170-x	138
752.45.04	35	767.57.xx	7	875.30.xx	47	81421431	65
752.62.xx	14	767.69.xx	5	875.54.xx	47	81421441	65
752.72.xx	35	776.50.xx	108	875.59.xx	47	81421451	65
752.75.xx	35	776.51.xx	108	877.00.xx	49	81427431	65
752.81.xx	22	776.52.xx	108	877.01.xx	49		
752.82.xx	21	776.53.xx	108	877.02.xx	49		