

**Elastomeric Couplings**  
**Omega**® **Family**

# REX OMEGA® COUPLINGS

## NO OTHER COUPLING CAN OFFER ALL THESE FEATURES & BENEFITS



Features	Benefits
Split-In-Half Flex Element Design	Easy replacement without moving the hubs or connected equipment
Polyurethane Flex Element	No lubrication required, excellent chemical resistance
Torsionally Soft	Protects equipment by cushioning shock loads and torsional vibration
High Misalignment Capacity	Accommodates unavoidable misalignment with low reactionary forces
Visual Inspection	No need for coupling disassembly to inspect
Interchangeable Hubs	Standard and spacer coupling hubs are identical
Adjustable Spacer	One spacer coupling size can accommodate different shaft separations

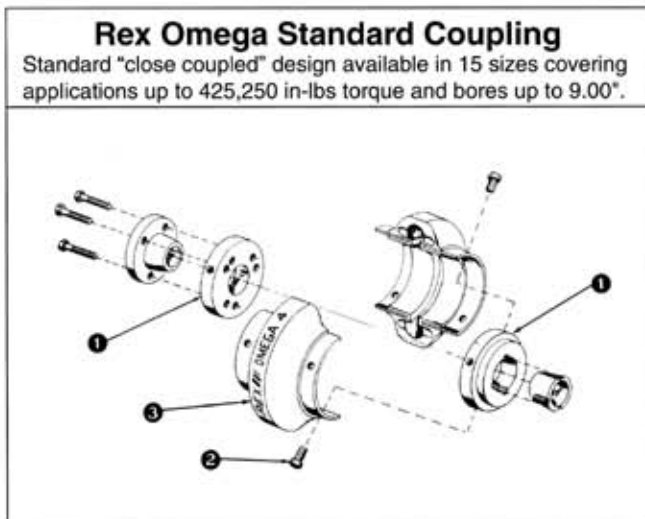

- ❶ Reversible hubs are available from "stock" with rough bore, finished straight bore, or bored to accept compression bushings. Consult factory for tapered bores, splines and other special bore requirements.
- ❷ Premium grade capscrews with self-locking patches. Also available in stainless steel.

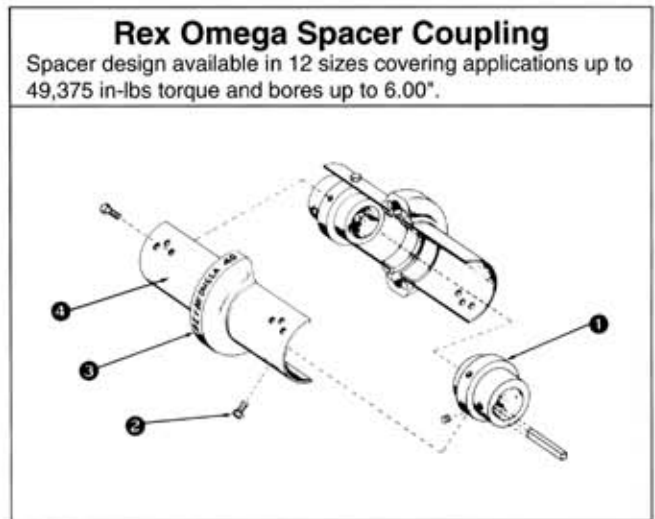

- ❸ Tough, two-piece urethane flex element transmits torque, accepts misalignment, reduces vibration and noise and is not seriously affected by petroleum products or most chemicals.
- ❹ Formed metal shoes with optional hub mounting patterns satisfy ANSI, DIN and ISO spacer requirements. Shoes are coated to help resist corrosion. Available in stainless steel.

### Table of Contents

Installation and Misalignment Ratings .....	E-3
Standard Close Coupled Design .....	E-4,5
Spacer Design.....	E-6,7,8
Extended Spacer Design.....	E-9
Floating Shaft Design .....	E-10,11
Mill Motor Design .....	E-12
Special Designs .....	E-13
Selection .....	E-14,15,16
Bore Specifications and Finished Stock Bore Hubs .....	E-17
Ordering.....	E-18
Sales and Service Center Locations.....	E-19



Mount one hub to shaft, leave other hub loose for adjustment of spacing.

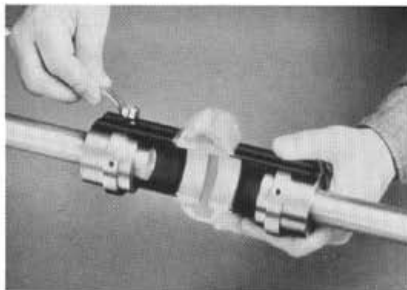

Place half of the Omega element around hubs and secure with self-locking capscrews. Omega element will space the other hub. Now secure the other hub.



Mount other half of the Omega element. Tighten all capscrews to recommended torques below and you're done! Refer to the installation instructions for further details.

### Tested Tough

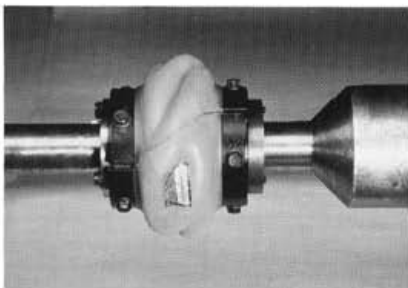

Severe static testing (5 x rating) shows element flexibility, rugged design, and positive adhesive bond to the metal shoes.

Rigorous testing demonstrates that the Rex Omega coupling protects connected equipment from the damaging effects of misalignment, vibration, and gross overload. Where other coupling designs might allow equipment damage, the super flexible element of Rex Omega couplings minimizes the reactionary forces on equipment bearings under severe misalignment conditions and reduces the effects of excessive shock overloads.

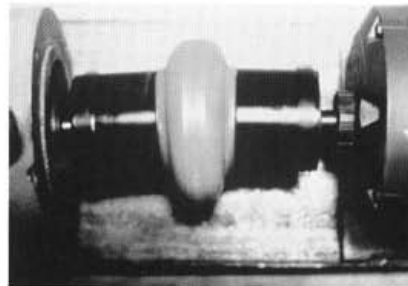

Demonstrates coupling's ability to accept severe misalignment.

### Omega Coupling Allowable Misalignment

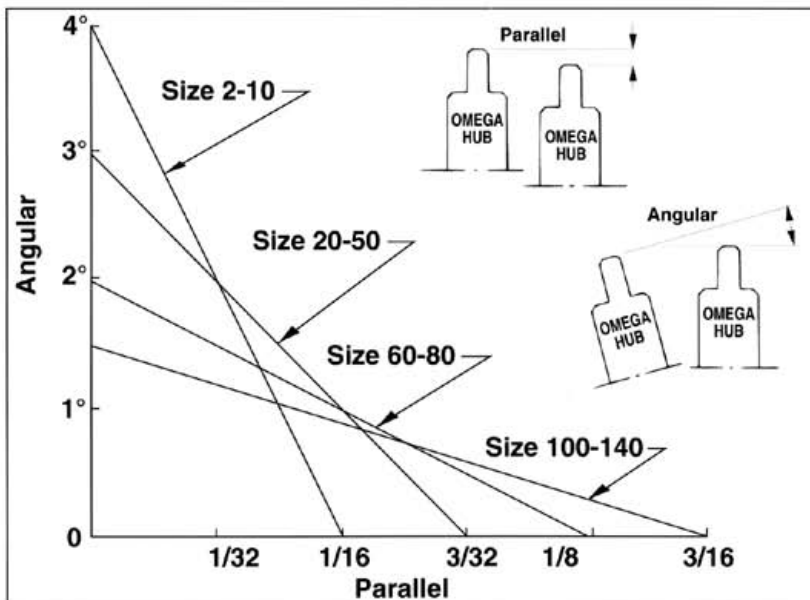

**Note:**

Any combination of parallel and angular misalignment which falls under the triangle will not cause a premature fatigue failure of the flexible element in normal use.

**Important Note:**

Coupling alignment is directly related to smooth, efficient equipment operation. Care should be taken for best possible alignment.

—IMPORTANT—  
RECOMMENDED CAPSCREW TORQUE  
FOR PROPER INSTALLATION

Cplg. Size	Torque — Dry	
	In. Lbs.	Ft. Lbs.
2	204	17
3		
4		
5		
10		
20	360	30
30		
40		
50		
60	900	75
70		
80		
100	3240	270
120		
140	7080	590

*NOTE:* Capscrews have self-locking patches which should not be reused more than twice. Capscrews can be further used if a thread locking adhesive is applied.

*Do NOT Lubricate Capscrew Threads*

# OMEGA® STANDARD COUPLING WITH STRAIGHT BORE HUBS

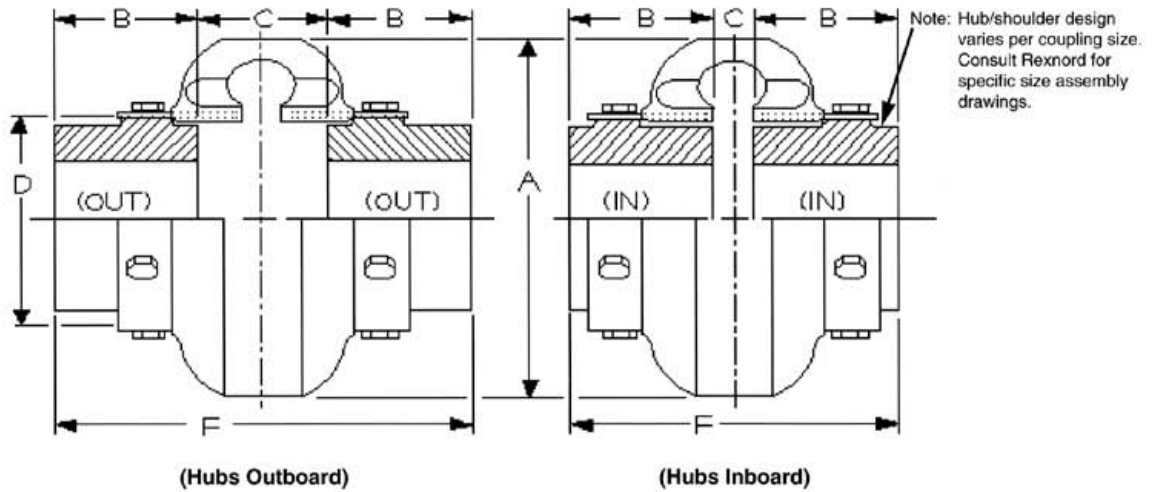

Specification Data With Straight Bore Hubs

Standard Omega No.	Recom. Max. Bore (In.) Ⓢ	HP/100 RPM Ⓢ	Continuous Torque (In. Lbs.) Ⓢ	Max. RPM	Dimensions In Inches							Weight (Lb.) Ⓢ
					A	B	C		D	F		
							(In.)	(Out)		(In.)	(Out)	
E2	1.13	.30	190	7500	3.50	.94	1.34	1.90	1.85	3.22	3.78	1.2
E3	1.38	.58	365	7500	4.00	1.50	.81	1.31	2.32	3.81	4.31	2.4
E4	1.63	.88	550	7500	4.56	1.69	.44	1.31	2.60	3.81	4.69	3.0
E5	1.88	1.48	925	7500	5.38	1.75	.81	1.81	3.13	4.31	5.31	5.4
E10	2.13	2.30	1450	7500	6.38	1.88	.56	1.81	3.65	4.31	5.56	8.2
E20	2.38	3.65	2300	6600	7.25	2.06	.50	2.38	4.48	4.62	6.50	13.0
E30	2.88	5.79	3650	5800	8.25	2.31	.56	2.44	5.42	5.19	7.06	21.2
E40	3.38	8.85	5500	5000	9.50	2.50	.56	2.68	6.63	5.56	7.68	35
E50	3.63	12.14	7650	4200	11.00	2.75	.63	3.38	8.13	6.13	8.88	54
E60	4.00	19.84	12,500	3800	12.50	3.25	.69	3.44	8.75	7.19	9.94	72
E70	4.50	35.12	22,125	3600	14.00	3.62	.75	3.75	9.25	8.00	11.00	86
E80	6.00	62.70	39,500	2000	16.00	4.87	.75	5.00	11.25	10.50	14.75	170
E100	6.75	135	85,050	1900	21.00	5.50	1.75	3.75	14.13	12.75	14.75	244
E120	7.50	270	170,100	1800	25.00	6.00	2.25	4.88	17.63	14.24	16.88	425
E140	9.00	540	340,200	1500	30.00	7.00	3.00	5.00	20.88	17.00	19.00	746

- Ⓢ Standard hubs. See page E-16 for steel hub maximum bores.
- Ⓢ Service factor = 1.0
- Ⓢ With maximum bore standard hubs.

### • Split-In-Half Flex Element

Allows disassembly and replacement without disturbing hubs or connected equipment.

### • Reversible Hubs

Accommodates different shaft spacing requirements, and allows compression bushings to be installed from either side of the hub.



Straight Bore Hubs



QD Hubs and Bushings



TAPER-LOCK® Hubs and Bushings

Note: Dimensions subject to change. Certified drawings of ordered material furnished on request.



# OMEGA® STANDARD COUPLING WITH COMPRESSION BUSHED HUBS

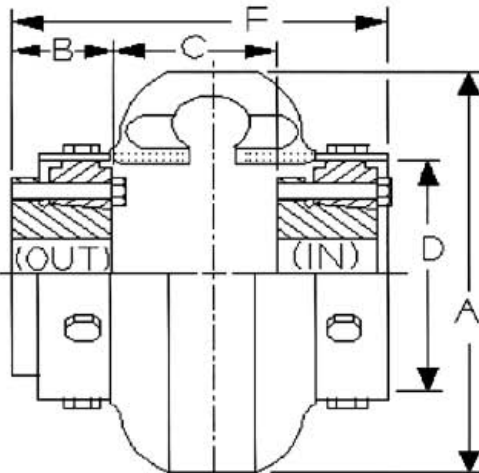

QD

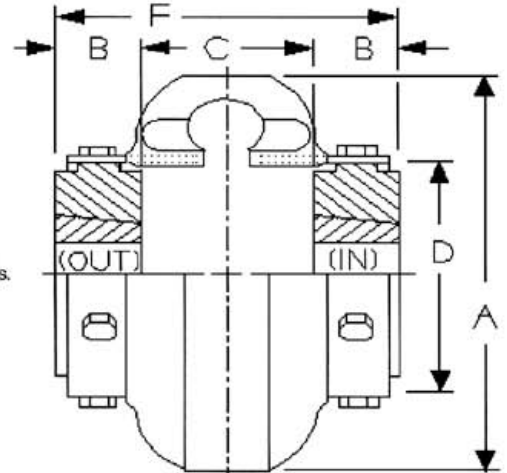

TAPER-LOCK®  
(E3-E80 Dwg. Only)

NOTE: Bushings are "NOT" included with hubs.

Specification Data With QD Hubs

Omega Coupling No.	QD Bush. No.	Recom. Max. Bore (In.) Ⓣ	HP/100 RPM Ⓣ	Continuous Torque (In. Lbs.) Ⓣ	Max. RPM	Dimensions In Inches						Weight (Lb.) Ⓣ	
						A	B	C		D	F		
								(In.) Ⓣ	(Out)		(In.) Ⓣ		(Out)
E4	JA	1.25	.88	550	7500	4.56	1.00	1.22	1.88	2.60	3.22	3.88	2.1
E5	SH	1.63	1.48	925	7500	5.38	1.25	1.75	1.88	3.13	4.25	4.50	3.6
E10	SDS	1.94	2.30	1450	7500	6.38	1.31	1.19	2.31	3.65	3.81	4.94	4.8
E20	SK	2.50	3.65	2300	6600	7.25	1.88	0.62	2.62	4.48	4.25	6.38	8.5
E30	SF	2.81	5.79	3650	5800	8.25	2.00	1.44	2.19	5.42	5.44	6.19	14.0
E40	E	3.50	8.85	5500	5000	9.50	2.63	1.25	1.75	6.63	6.50	7.00	23.8
E50	E	3.50	12.14	7650	4200	11.00	2.63	1.37	2.88	8.13	6.63	8.13	37.6
E60	F	3.94	19.84	12,500	3800	12.50	3.63	1.50	1.89	8.75	8.75	9.13	45.5
E70	J	4.50	35.12	22,125	3600	14.00	4.50	1.31	1.43	9.25	10.31	10.43	68.1
E80	M	5.50	62.70	39,500	2000	16.00	6.75	0.75	1.25	11.25	14.25	14.75	140
E100	M	5.50	135	85,050	1900	21.00	6.80	1.75	1.16	14.13	15.34	14.75	250
E120	N	6.00	270	150,000Ⓣ	1800	25.00	8.12	1.74	1.16	17.63	17.96	17.38	475
E140	P	7.00	540	250,000Ⓣ	1500	30.00	9.36	0.30	3.00	20.88	21.78	19.00	782

NOTE: Dimensions may vary depending on bushing manufacturer.

Specification Data With TAPER-LOCK® Hubs

Omega Coupling No.	Bush. No.	Recom. Max. Bore (In.) Ⓣ	HP/100 RPM Ⓣ	Continuous Torque (In. Lbs.) Ⓣ	Max. RPM	Dimensions In Inches					Weight (Lb.) Ⓣ		
						A	B	C		D		F	
								(In.) Ⓣ	(Out)		(In.) Ⓣ	(Out)	
E3	1008	1.00	.58	365	7500	4.00	.88	1.68		2.32	3.44		1.8
E4	1008	1.00	.88	550	7500	4.56	.88	1.68		2.60	3.44		2.6
E5	1108	1.13	1.48	925	7500	5.38	.88	2.19		3.13	3.94		4.0
E10	1310	1.44*	2.30	1450	7500	6.38	1.00	2.06		3.65	4.06		6.0
E20	1610	1.69*	3.65	2300	6600	7.25	1.00	2.50		4.48	4.50		9.0
E30	2012	2.12*	5.79	3650	5800	8.25	1.25	2.56		5.42	5.06		13.6
E40	2517	2.69*	8.85	5500	5000	9.50	1.75	2.38		6.63	5.88		21.8
E50	2517	2.69*	12.14	7650	4200	11.00	1.75	3.00		8.13	6.50		31.5
E60	3020	3.25*	19.84	12,500	3800	12.50	2.00	3.31		8.75	7.31		46.6
E70	3535	3.94	35.12	22,125	3600	14.00	3.50	2.38		9.25	9.38		66.7
E80	4040	4.44	62.70	39,500	2000	16.00	4.00	3.75		11.25	11.75		82
E100	4545	4.94	135	85,050	1900	21.00	4.50	1.50	6.00	14.13	10.50	15.00	250
E120	5050	5.00	270	126,000Ⓣ	1800	25.00	5.00	2.00	7.13	17.63	12.00	17.13	408
E140	7060Ⓣ	7.00Ⓣ	540	340,200	1500	30.00	6.00	3.00	7.00	20.88	15.00	19.00	660

Ⓣ With shallow keyway. \* With steel bushings.

Ⓣ Service Factor = 1.0. This rating may be lower if limited by the bushing rating, particularly if severe service conditions exist. Consult bushing manufacturer.

Ⓣ Without compression bushings.

Ⓣ Inboard hub mounting (see drawing page E-4) requires bushing installation from coupling ends. Allow space (extra "B" dimension) between coupling ends and equipment for bushing assembly/disassembly. Reverse taper hubs are available; consult Rexnord.

Ⓣ A 8065 bushing hub with 8.00" max bore is also available. Consult Rexnord.

Ⓣ Maximum bushing rating.

Ⓣ TAPER-LOCK® is the registered trademark of Reliance Electric Company.

Note: Dimensions subject to change. Certified drawings of ordered material furnished on request.

# OMEGA® SPACER COUPLING WITH STRAIGHT BORE HUBS

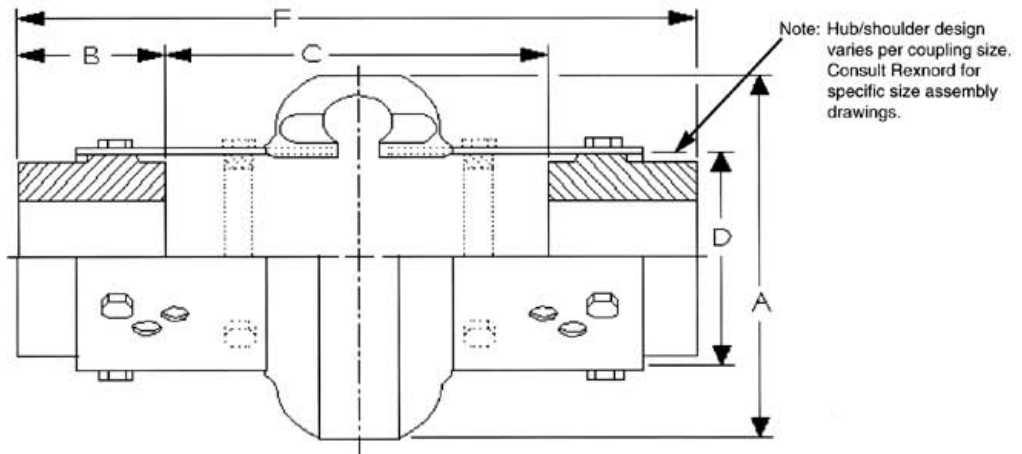

Specification Data With Straight Bore Hubs

Spacer Omega No.Ⓐ	Recom. Max Bore (In.)	HP/100 RPM Ⓞ	Continuous Torque (In. Lbs.) Ⓞ	Max. RPM Ⓞ	Dimensions In Inches							Weight (Lb.) Ⓞ
					A	B	C		D	F		
							Min. Ⓞ	Max.		Min. Ⓞ	Max.	
ES2-R	1.13	.30	190	7500	3.50	.94	3.50	4.00	1.85	5.75	5.92	2.3
ES3-R	1.38	.58	365	7500	4.00	1.50	3.50	5.00	2.32	7.25	8.00	4.0
ES4-R	1.63	.88	550	7500	4.56	1.69	3.50	5.00	2.60	7.25	8.38	5.1
ES5-R	1.88	1.48	925	7500	5.38	1.75	3.50	5.00	3.13	7.25	8.50	7.5
ES10-R	2.13	2.30	1450	7500	6.38	1.88	3.50	5.00	3.65	7.25	8.75	10.3
ES20	2.38	3.65	2300	4800	7.25	2.06	2.55	7.00	4.48	9.38	11.12	15.6
ES30	2.88	5.79	3650	4200	8.25	2.31	2.05	7.00	5.42	9.38	11.62	25.1
ES40	3.38	8.85	5500	3600	9.50	2.50	1.67	7.00	6.63	9.38	12.00	40
ES50	3.63	12.14	7650	3100	11.00	2.75	1.17	7.00	8.13	9.38	12.50	60
ES60	4.00	19.84	12,500	2800	12.50	3.25	2.67	9.75	8.75	12.50	16.25	84
ES70	4.50	35.12	22,125	2600	14.00	3.62	1.99	9.75	9.25	12.50	17.00	102
ES80	6.00	62.70	39,500	1800	16.00	4.87	2.18	9.75	11.25	12.50	19.50	180

- Ⓐ Suffix "R" designates high speed ring design. Rings are furnished as standard for sizes ES2-R to ES10-R, optional on sizes ES20 to ES80.
- Ⓞ Service factor = 1.0
- Ⓞ Spacer couplings furnished with optional high speed rings (sizes ES20 to ES80) can be operated up to the maximum speeds for standard series couplings. See RPM ratings on page E-4.
- Ⓞ Minimum shaft spacing is 0.25 inch. See page E-8 for additional information.
- Ⓞ Overall length of element.
- Ⓞ With max bore standard hubs.

## • Adjustable Spacer Design

Optional hole mounting positions and reversible hub features allow adjustment to accommodate most shaft spacing requirements (see Page E-8).

## • Universal Hubs

Straight bore and compression bushed hub designs are identical and interchangeable for both the spacer and standard couplings. This means maximum utilization of off the shelf inventory.



Straight Bore Hubs



QD Hubs and Bushings



TAPER-LOCK® Hubs and Bushings

Note: Dimensions subject to change. Certified drawings of ordered material furnished on request.

# OMEGA® SPACER COUPLINGS WITH COMPRESSION BUSHED HUBS

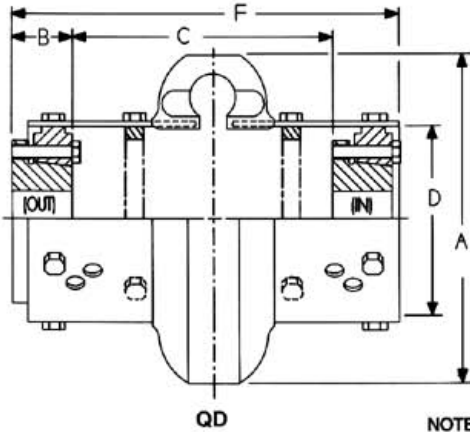

**QD**

NOTE: Bushings are "NOT" included with hubs.

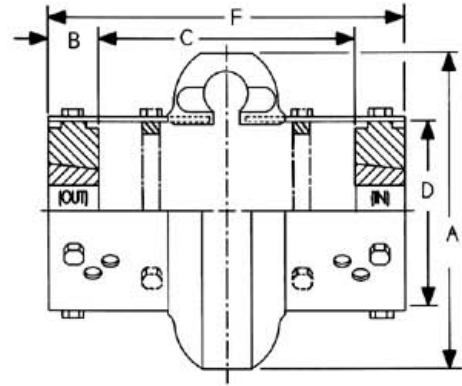

**TAPER-LOCK®**

### Specification Data With QD Hubs

Spacer Omega No. ①	QD Bush. No.	Recom. Max. Bore (In.) ②	HP/100 RPM ③	Continuous Torque Rating (In. Lbs.) ④	Max RPM ⑤	Dimensions In Inches						Weight (Lb.) ⑥	
						A	B	C		D	F		
								Min. ⑦	Max.		Min.		Max.
ES4-R	JA	1.25	0.88	550	7500	4.56	1.00	3.24	5.56	2.60	7.25	7.71	4.2
ES5-R	SH	1.63	1.48	925	7500	5.38	1.25	3.51	5.06	3.13	7.25	7.82	5.7
ES10-R	SDS	1.94	2.30	1450	7500	6.38	1.31	3.60	5.49	3.65	7.25	8.24	6.9
ES20	SK	2.50	3.65	2300	4800	7.25	1.88	2.82	6.96	4.48	9.38	10.84	11.1
ES30	SF	2.94	5.79	3650	4200	8.25	2.00	3.36	6.44	5.42	9.38	10.32	17.9
ES40	E	3.44	8.85	5500	3600	9.50	2.63	2.94	5.74	6.63	9.38	10.71	28.8
ES50	E	3.44	12.14	7650	3100	11.00	2.63	2.44	6.24	8.13	9.38	11.21	43.6
ES60	F	3.94	19.84	12,500	2800	12.50	3.63	4.25	7.68	8.75	12.50	14.65	57.4
ES70	J	4.44	35.12	22,125	2600	14.00	4.50	3.50	6.72	9.25	12.52	15.40	84.1
ES80	M	5.50	62.70	39,500	1800	16.00	6.75	1.35	4.76	11.25	14.17	17.58	150.0

NOTE: Dimensions may vary depending on bushing manufacturer.

### Specification Data With TAPER-LOCK® Hubs

Spacer Omega No. ①	Bush. No.	Recom. Max. Bore (In.) ②	HP/100 RPM ③	Continuous Torque Rating (In. Lbs.) ④	Max RPM ⑤	Dimensions In Inches						Weight (Lb.) ⑥	
						A	B	C		D	F		
								Min. ⑦	Max.		Min.		Max.
ES3-R	1008	1.00	0.58	365	7500	4.00	0.88	3.83	5.38	2.32	7.25	7.25	3.2
ES4-R	1008	1.00	0.88	550	7500	4.56	0.88	3.83	5.38	2.60	7.25	7.25	4.2
ES5-R	1108	1.13	1.48	925	7500	5.38	0.88	3.83	5.38	3.13	7.25	7.25	6.0
ES10-R	1310	1.44*	2.30	1450	7500	6.38	1.00	3.71	5.25	3.65	7.25	7.25	7.9
ES20	1610	1.69*	3.65	2300	4800	7.25	1.00	4.84	6.75	4.48	9.38	9.38	11.9
ES30	2012	2.12*	5.79	3650	4200	8.25	1.25	4.59	6.50	5.42	9.38	9.38	18.0
ES40	2517	2.69*	8.85	5500	3600	9.50	1.75	4.09	6.00	6.63	9.38	9.59	26.8
ES50	2517	2.69*	12.14	7650	3100	11.00	1.75	4.09	6.00	8.13	9.38	9.59	37.4
ES60	3020	3.25*	19.84	12,500	2800	12.50	2.00	6.09	8.75	8.75	12.50	12.84	60.7
ES70	3535	3.94	35.12	22,125	2600	14.00	3.50	4.59	7.34	9.25	12.50	14.34	81.4
ES80	4040	4.44	62.70	39,500	1800	16.00	4.00	4.09	6.84	11.25	12.50	14.84	93.2

① Suffix "R" designates high speed ring design. Rings are furnished standard for sizes ES2-R to ES10-R, optional for sizes ES20 to ES80.

② With shallow keyway. \*With extended bore bushings.

③ Service factor = 1.0. This rating may be lower if limited by the bushing rating, particularly if severe service conditions exist. Consult bushing manufacturer.

④ Spacer couplings furnished with optional high speed rings (sizes ES20 to ES80) can be operated up to maximum allowable speeds for standard series couplings.

⑤ Minimum shaft spacing is 0.25 inch. See page E-8 for additional information.

⑥ Without compression bushings.

⑦ TAPER-LOCK® is the registered trademark of Reliance Electric Company.

**Note: Dimensions subject to change. Certified drawings of ordered material furnished on request.**

## Shaft Spacing Possibilities (Using Straight Bore Hubs)

The Omega spacer coupling design (page E-6 & E-7) provides a clear space between hubs. There are no interfering center members or spools. Thus, shaft spacings as small as 1/4 inch can be achieved. However, for such small spacings, use of the standard Omega coupling would be recommended. The maximum shaft spacing for each coupling is shown on page E-6 & E-7. Any ANSI, ISO or DIN spacing between 1/4 inch and the maximum listed can be achieved without any additional parts. Hubs can be placed on the shafts as shown below.

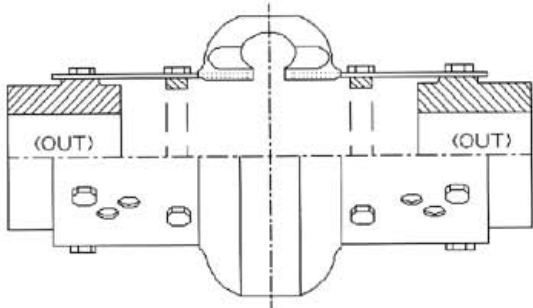

Figure A  
Both hubs mounted outward

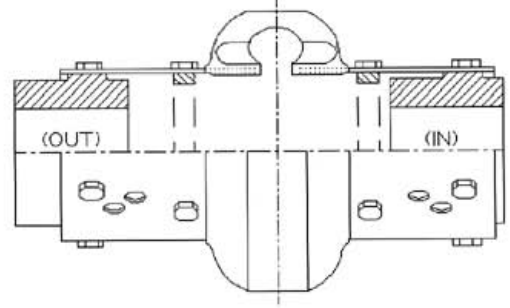

Figure B  
One hub mounted inward  
One hub mounted outward

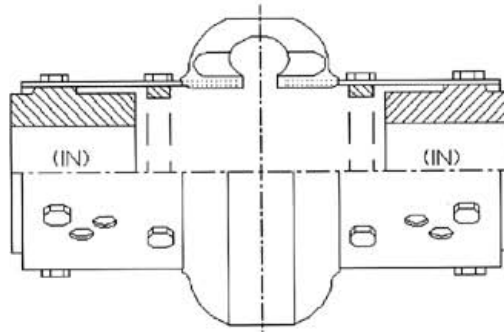

Figure C  
Both hubs mounted inward

Use one half of the flex element to establish shaft spacing and appropriate mounting position. Optional hole mounting positions and reversible hubs allow adjustments as needed. Select the combination which most closely matches the dimensions desired between shafts (Figure D). Drawings with specific mounting positions/dimensions are available from Rexnord.

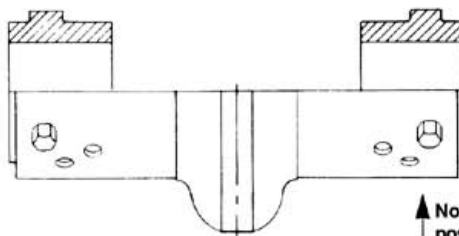

Figure D

▲ Note: Optional cap screw hole mounting positions allow easy on-site adjustment to meet various shaft spacing requirements.

Hubs can be flush with the shaft end (not shown), extended beyond the end of the shaft (Figure E) or recessed behind the shaft end provided there is sufficient keyway engagement (Figure F). Special sleeve extensions (See Page E-9) are available for spacing requirements in excess of those listed on pages E-6 & E-7.

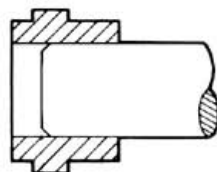

Figure E

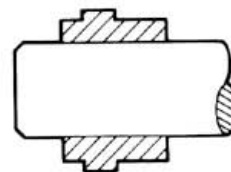

Figure F

**Note:** Shaft engagement should be equal to or greater than .8 times shaft diameter. 100% shaft engagement is suggested for compression bushed hubs.



# OMEGA® EXTENDED SPACER COUPLING

Omega extended spacer couplings are designed to connect equipment with shaft spacing requirements beyond the Omega spacer coupling capabilities. They are ideal for applications with wide non-standard shaft gaps, and can be an economic alternative to floating shaft couplings (i.e. stock pump applications.)

Sleeve extensions ("SE") are furnished in steel. They mount to regular Omega spacer elements (standard elements for sizes E100 & E120) and cast iron or steel hubs — straight bore or compression bushed design. By adjusting the hub/shaft engagement (see figures E & F on page E-8) and spacer element mounting position, the Omega extended spacer coupling can be utilized for many shaft spacing requirements.

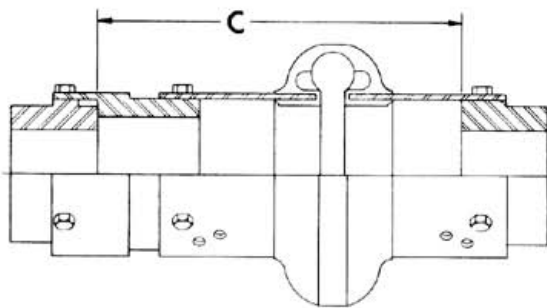

Single Extension

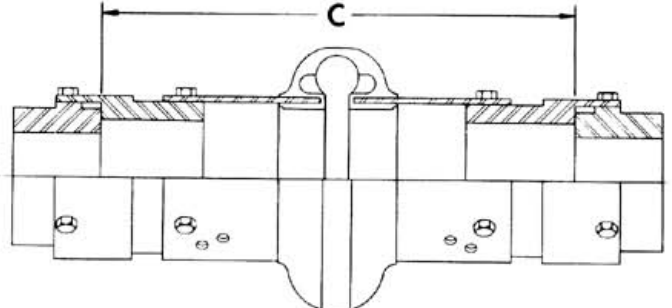

Double Extension

Maximum Spacing® – "C" Dimension – Inches

Spacer Coupling Size	Max. RPM Std.	Max. RPM @ Matched Assembly	With SHRB Hubs			With HQD Hubs			With HTL Hubs			Weight (Lb.) One SE
			Max. Without SE	One SE	Two SE	Max. Without SE	One SE	Two SE	Max. Without SE	One SE	Two SE	
ES3-R	1800	3600	5.00	7.00	9.00	----	----	----	5.38	7.38	9.38	1.2
ES4-R	1800	3600	5.00	7.00	9.00	5.56	7.56	9.56	5.38	7.38	9.38	1.4
ES5-R	1800	3600	5.00	7.00	9.00	5.06	7.06	9.06	5.38	7.38	9.38	1.5
ES10-R	1800	3600	5.00	7.00	9.00	5.49	7.49	9.49	5.25	7.25	9.25	1.6
ES20	1800	3600	7.00	9.75	12.50	6.96	9.71	12.46	6.75	9.50	12.25	3.7
ES30	1800	3600	7.00	9.75	12.50	6.44	8.97	11.72	6.50	9.25	12.00	4.5
ES40	1800	3600	7.00	9.75	12.50	5.74	8.23	10.98	6.00	8.75	11.50	5.3
ES50	1800	3100	7.00	9.75	12.50	6.24	8.73	11.48	6.00	8.75	11.50	8.0
ES60	1800	2800	9.75	14.38	19.00	7.68	12.31	16.93	8.75	13.38	18.00	20.8
ES70	1800	2600	9.75	15.13	20.50	6.72	12.10	17.47	7.34	12.72	18.09	34.6
ES80	1500	1800	9.75	15.38	21.00	4.76	10.39	16.01	6.84	12.37	18.00	46.2
E100	1500	1800	3.75	8.75	13.75	1.75	7.00	12.25	6.00	11.25	16.50	76.0
E120	1500	1800	4.88	10.13	15.38	1.74	6.74	11.74	7.13	12.13	17.13	81.3

① Maximum spacings shown are with hubs mounted outward and flush with shaft ends. Longer custom length extensions are available; consult Rexnord.

② Hub/sleeve extension assembly precisely machined and matched to obtain higher speed rating. Specify "Matched Assembly" when ordering.

**ORDER INFORMATION:** When ordering, be sure to specify whether one or two sleeve extensions are required. If custom length, specify distance between shaft ends.

• **Optional sleeve extensions ("SE")**

An economical alternative to floating shaft couplings (i.e., stock pump applications).

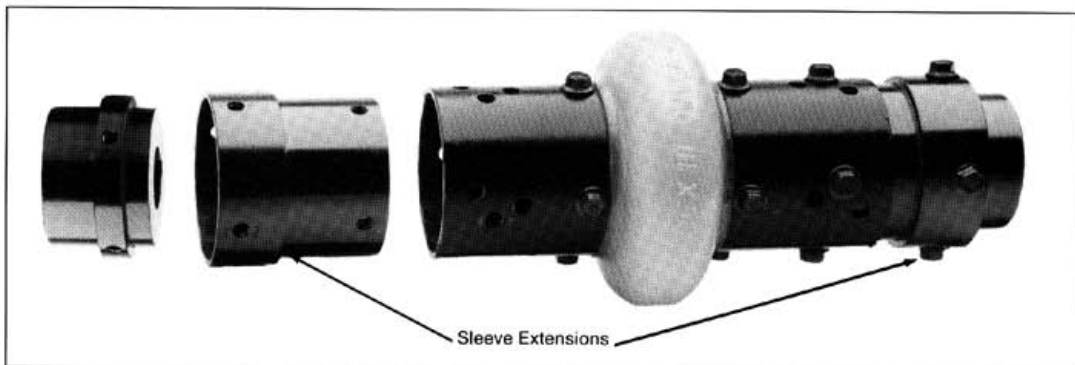

**Note:** Dimensions subject to change. Certified drawings of ordered material furnished on request.

# OMEGA® PILOTED FLOATING SHAFT COUPLINGS (COOLING TOWER DRIVE COUPLINGS)



## Super Flexible Polyurethane Elements:

Protects equipment from the damaging effects of misalignment and shock loads. Elements are split longitudinally for easy assembly/disassembly.

## Specially Designed Capture Feature:

Minimizes chances for catastrophic failures resulting from fatigue or excessive misalignment.

## Optional Center Members:

Steel, stainless steel or composite materials are available depending on application and environmental requirements.

## No Lubrication:

Pilot bushing and polyurethane element do not require lubrication.

## Corrosion Resistance:

Nickel plated steel, stainless steel, composite material, or acid and alkali protective coatings are available.

## Long Span Capability:

Optional composite tubes allow significantly longer span capabilities than conventional steel tubes.

Rex Omega Piloted floating shaft couplings are utilized to connect equipment which is relatively far apart. Such arrangements are particularly suited to transmit torque into areas where moisture, dust or corrosive conditions would be detrimental to driving machinery.

Typical applications include cooling tower drives, steel mill roll drives and paper machine drives<sup>Ⓢ</sup>.

The Omega coupling's floating center member may be either solid or tubular, depending upon the system requirements. The assembly is piloted at each end by a resilient rubber bushing

assembly which eliminates the need for intermediate support bearings.

Besides reliability, safety was engineered into the design by incorporation of the captured center member feature, which minimizes the possibility of a catastrophic failure due to fatigue or severe misalignment.

Omega Piloted floating shaft couplings are designed to alleviate situations where excessive misalignment in cooling tower applications are troublesome.

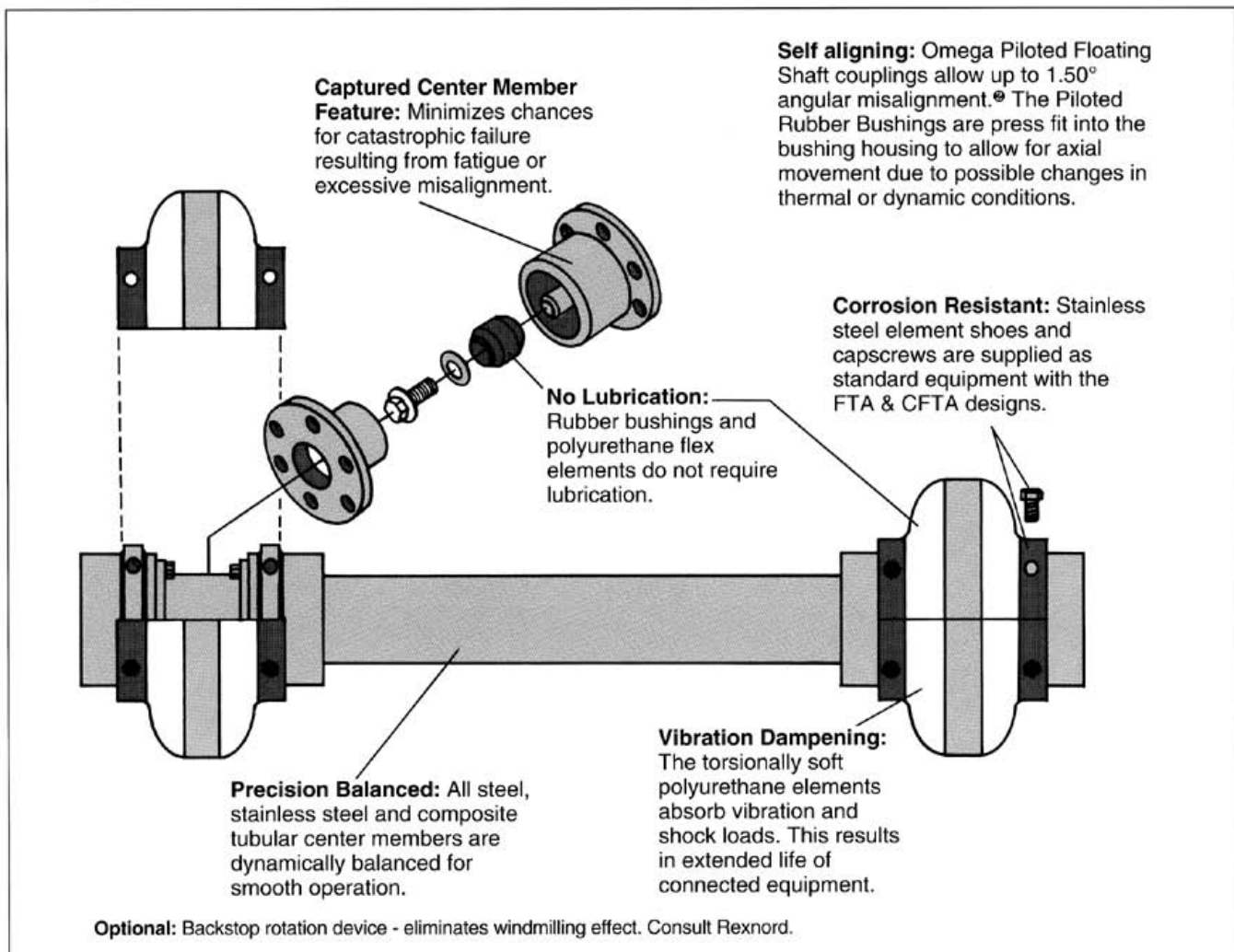

Ⓢ Consult Rexnord for torsional stiffness data relative to this application.

Ⓢ Equivalent to .026 inches per inch of shaft spacing (L dimension). **\*Note:** Coupling alignment is directly related to equipment and coupling life. Care should be taken for best possible alignment.

# OMEGA® PILOTED FLOATING SHAFT COUPLINGS (COOLING TOWER DRIVE COUPLINGS)

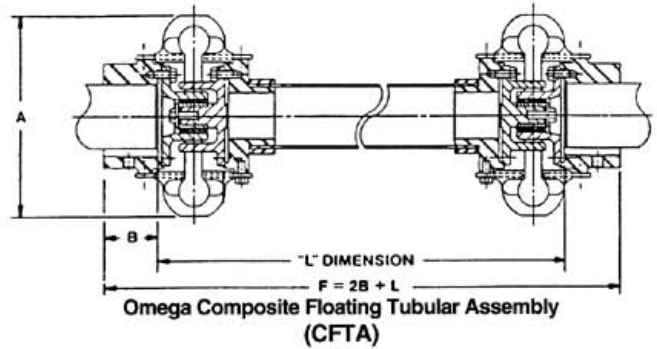
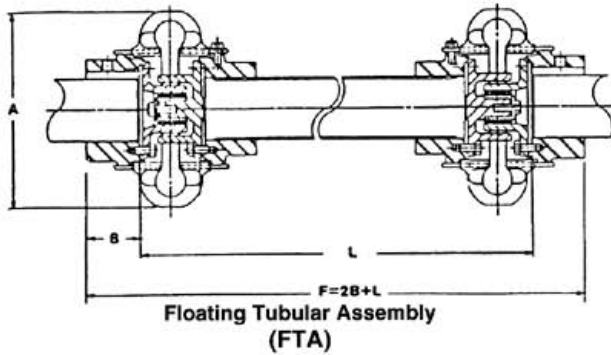

### Specification Data

Omega Size No.	HP/100 RPM	Continuous Torque @ Capacity (In. Lbs.)	Max. RPM	Max. @ Bore (In.)	Dimensions (In.)		Minimum Span (L)	Maximum Span (L) For Tube Design @ Max RPM	
					A	B		Steel FTA (In.) @	Composite CFTA (In.) @
E10	2.30	1450	1800	2.13	6.38	1.68	8.38	75	104
E20	3.65	2300	1800	2.38	7.25	1.88	9.88	85	104
E30	5.79	3650	1800	2.88	8.25	2.12	10.50	90	129
E40	8.85	5500	1800	3.38	9.50	2.31	11.50	100	129
E50	12.14	7650	1800	3.63	11.00	2.56	13.25	100	129
E60	19.84	12,500	1800	4.00	12.50	3.06	14.38	107	157
E70	35.12	22,125	1800	4.50	14.00	3.44	15.75	113	157
E80	62.70	39,500	1800	6.00	16.00	4.69	20.75	123	182
E100	135	85,050	1500	6.75	21.00	5.31	19.50	141	***
E120	270	170,100	1200	7.50	25.00	5.81	21.38	147	***
E140	540	340,200	1200	9.00	30.00	7.00	***	***	***

① Service Factor - 1.0 (2.0 Service Factor recommended for cooling tower applications).

② With straight bore hubs.

③ Longer spans are possible at slower speeds or with special "EL" (extra long/oversize) tubes. Adjustable length center tube design is also available.

\*\*\* Consult factory.

**Also available in two solid shaft arrangements**

Consult Rexnord for specifications and application assistance.

FTA and CFTA Material Classification (hubs and piloted bushing support hardware)	
Class D	Type 303-304 Stainless Steel Tube, Nickel Plated Hubs & Bushing Assemblies with Stainless Steel Elements & Hardware
Class E	Type 303-304 Stainless Steel Tube, Hubs & Bushing Assemblies with Stainless Steel Elements & Hardware.
Class DC	Composite Tube, Nickel Plated Hubs & Bushing Assemblies with Stainless Steel Elements & Hardware.
Class EC	Composite Tube, Type 303-304 Stainless Steel Hubs & Bushing Assemblies with Stainless Steel Elements & Hardware.

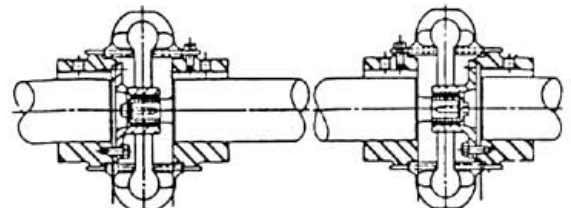

**Piloted Shaft Assembly (PSA)**

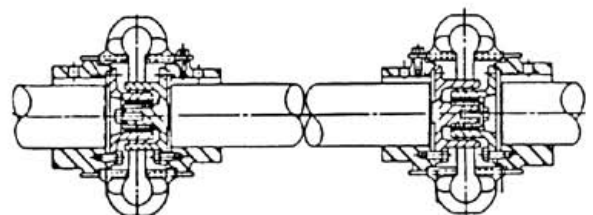

**Floating Shaft Assembly (FSA)**

# OMEGA® MILL MOTOR COUPLINGS

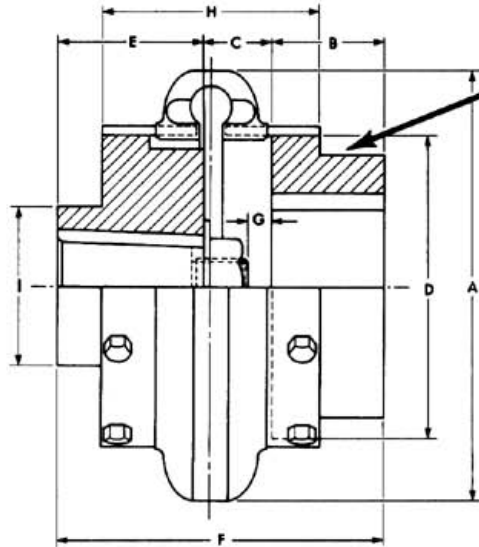

Note: Hub/shoulder design varies per coupling size. Consult Rexnord for specific size assembly drawings.

Mill Motor Coupling Dimensions

Coupling Size	Mill Motor Size	Max. RPM	HP/100 RPM*	Complete Coupling Wt., Lbs.	Dimensions									Max. Straight Bore
					A	B	C	D	E	F	G	H	I	
10	802A 602	7500	2.3	15.6	6 <sup>3</sup> / <sub>8</sub>	17 <sup>1</sup> / <sub>8</sub>	19 <sup>1</sup> / <sub>32</sub>	35 <sup>5</sup> / <sub>8</sub>	3	6 <sup>5</sup> / <sub>32</sub>	1 <sup>1</sup> / <sub>32</sub>	31 <sup>13</sup> / <sub>16</sub>	27 <sup>1</sup> / <sub>8</sub>	2 <sup>1</sup> / <sub>8</sub>
20	802B 802C	6600	3.65	25.4	7 <sup>1</sup> / <sub>4</sub>	2 <sup>1</sup> / <sub>16</sub>	15 <sup>5</sup> / <sub>8</sub>	4 <sup>1</sup> / <sub>2</sub>	3	6 <sup>11</sup> / <sub>16</sub>	9 <sup>1</sup> / <sub>16</sub>	4 <sup>1</sup> / <sub>4</sub>	3	2 <sup>3</sup> / <sub>8</sub>
	603								3 <sup>1</sup> / <sub>2</sub>	6 <sup>3</sup> / <sub>8</sub>	1 <sup>1</sup> / <sub>2</sub>			
30	803 804	5800	5.79	39.3	8 <sup>1</sup> / <sub>4</sub>	2 <sup>9</sup> / <sub>16</sub>	1 <sup>1</sup> / <sub>2</sub>	57 <sup>1</sup> / <sub>16</sub>	3 <sup>1</sup> / <sub>2</sub>	75 <sup>1</sup> / <sub>16</sub>	5 <sup>5</sup> / <sub>8</sub>	49 <sup>9</sup> / <sub>16</sub>	3 <sup>1</sup> / <sub>2</sub>	27 <sup>1</sup> / <sub>8</sub>
	603 604													
40	804 604	5000	8.85	58.0	9 <sup>1</sup> / <sub>2</sub>	2 <sup>1</sup> / <sub>2</sub>	1 <sup>1</sup> / <sub>2</sub>	6 <sup>5</sup> / <sub>8</sub>	3 <sup>1</sup> / <sub>2</sub>	7 <sup>1</sup> / <sub>2</sub>	1 <sup>1</sup> / <sub>2</sub>	47 <sup>7</sup> / <sub>8</sub>	3 <sup>1</sup> / <sub>2</sub>	3 <sup>3</sup> / <sub>8</sub>
50	406 806 606	4200	12.14	83.5	11	2 <sup>3</sup> / <sub>4</sub>	11 <sup>13</sup> / <sub>16</sub>	8 <sup>1</sup> / <sub>8</sub>	4	8 <sup>9</sup> / <sub>16</sub>	1 <sup>1</sup> / <sub>16</sub>	5 <sup>1</sup> / <sub>2</sub>	4	3 <sup>5</sup> / <sub>8</sub>
	408 608								4 <sup>1</sup> / <sub>2</sub>	9 <sup>1</sup> / <sub>16</sub>	9 <sup>1</sup> / <sub>16</sub>			
60	406 806	3800	19.84	120.3	12 <sup>1</sup> / <sub>2</sub>	3 <sup>1</sup> / <sub>4</sub>	1 <sup>3</sup> / <sub>4</sub>	8 <sup>3</sup> / <sub>4</sub>	4	9	5 <sup>5</sup> / <sub>8</sub>	6 <sup>5</sup> / <sub>16</sub>	4 <sup>1</sup> / <sub>2</sub>	4
	408 608								4 <sup>1</sup> / <sub>2</sub>	9 <sup>1</sup> / <sub>2</sub>	1 <sup>1</sup> / <sub>2</sub>			
70	408 808 608 410 810 610	3600	35.12	150	14	3 <sup>5</sup> / <sub>8</sub>	2 <sup>1</sup> / <sub>2</sub>	9 <sup>1</sup> / <sub>4</sub>	4 <sup>1</sup> / <sub>2</sub>	10 <sup>5</sup> / <sub>8</sub>	1 <sup>1</sup> / <sub>4</sub>	67 <sup>7</sup> / <sub>8</sub>	4 <sup>3</sup> / <sub>4</sub>	4 <sup>1</sup> / <sub>2</sub>
	412 612								5	11 <sup>1</sup> / <sub>16</sub>	1			
80	410 810	2000	62.7	235	16	47 <sup>7</sup> / <sub>8</sub>	3 <sup>1</sup> / <sub>8</sub>	11 <sup>1</sup> / <sub>4</sub>	4 <sup>1</sup> / <sub>2</sub>	12 <sup>1</sup> / <sub>2</sub>	1 <sup>3</sup> / <sub>4</sub>	9 <sup>1</sup> / <sub>4</sub>	6	6
	412 812 612						3 <sup>1</sup> / <sub>8</sub>		5	13	1 <sup>9</sup> / <sub>16</sub>			
100	614	1900	135	340	21	5 <sup>1</sup> / <sub>2</sub>	3 <sup>3</sup> / <sub>4</sub>	14 <sup>1</sup> / <sub>8</sub>	5	14 <sup>1</sup> / <sub>4</sub>	2 <sup>1</sup> / <sub>4</sub>	9 <sup>3</sup> / <sub>4</sub>	10 <sup>1</sup> / <sub>4</sub>	6 <sup>3</sup> / <sub>4</sub>
	812								5 <sup>1</sup> / <sub>2</sub>	14 <sup>3</sup> / <sub>4</sub>	2			
120	616 816	1800	270	520	25	6	47 <sup>7</sup> / <sub>8</sub>	17 <sup>5</sup> / <sub>8</sub>	5 <sup>1</sup> / <sub>2</sub>	14 <sup>3</sup> / <sub>4</sub>	2 <sup>7</sup> / <sub>16</sub>	11 <sup>9</sup> / <sub>16</sub>	11 <sup>3</sup> / <sub>4</sub>	7 <sup>1</sup> / <sub>2</sub>
	618 818								6	16 <sup>7</sup> / <sub>8</sub>	3 <sup>9</sup> / <sub>16</sub>			
140	818 620	1500	540	950	30	7	5	20 <sup>7</sup> / <sub>8</sub>	7.0	19.0	2 <sup>5</sup> / <sub>8</sub>	13	15	9
	622 624								7.0	19.0	2 <sup>5</sup> / <sub>8</sub>			



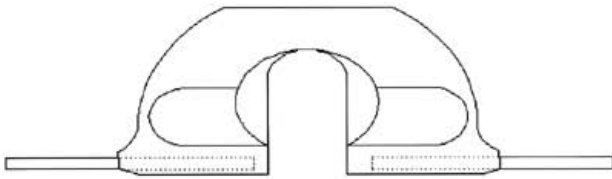

**Omega® Heavy-Duty Element**

25% higher torque capacity.  
Fits standard hubs.  
Available in all sizes.

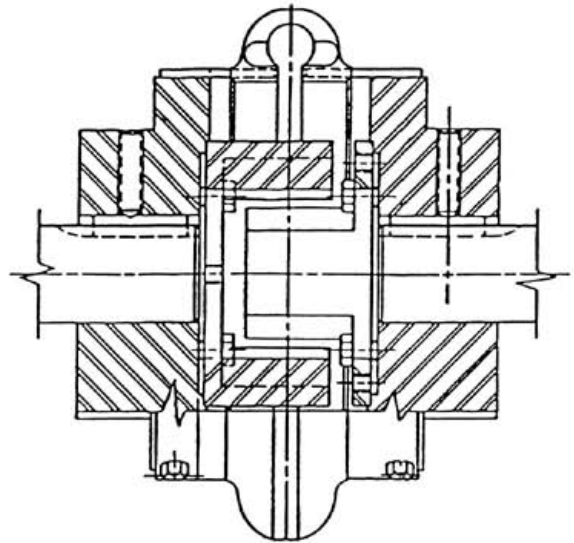

**Omega® Positive Drive Coupling**

With interlocking drive for short-term limited use.

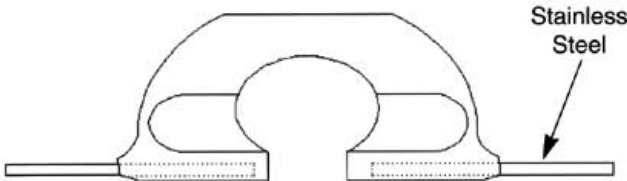

**Omega® Stainless Steel Element**

Corrosion resistant stainless steel shoes  
for severe environments i.e: cooling towers.  
Stainless steel hubs & capscrews also available.

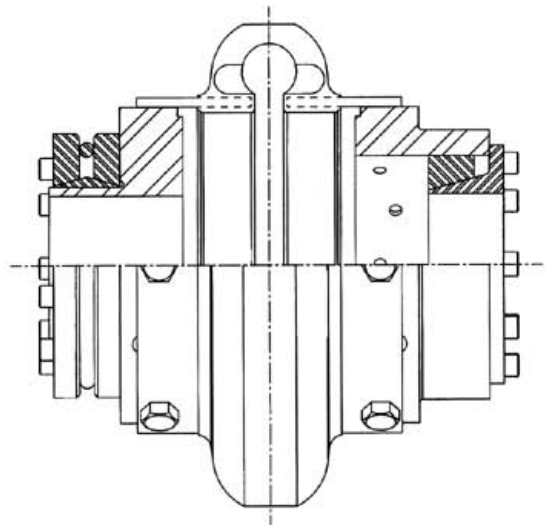

**Omega® Keyless Hub/Bushing Design**

Several optional keyless  
Hub/Bushing designs are available.



**Omega® Light-Duty Element**

Available in size E2LD only. Minimum O.D. (2.5") for  
tight applications. Max torque rating of 100 In. Lbs.

\*Contact factory for further information.

# COUPLING SELECTION SELECTION PROCEDURE



1. Calculate HP/100 RPM:  $HP/100 \text{ RPM} = \frac{\text{Horsepower} \times 100}{\text{RPM}}$
2. Determine service factor from table on page E-15. If not listed, see load classification table below. Remember to consider both driver and driven equipment and temperature limitations.
3. Multiply HP/100 RPM by the service factor to get equivalent HP/100 RPM.
4. Select coupling size from Table 1 with a rating equal to or greater than the equivalent HP/100 RPM determined in step 3.
5. Be sure that the operating speed of the coupling does not exceed maximum RPM listed on pages E-4 through E-7.
6. Select desired hub type and check maximum allowable coupling bore on page E-16.

**Table 1**

Size		Equivalent HP/100 RPM
Standard	Spacer	
E2	ES2	.30
E3	ES3	.58
E4	ES4	.88
E5	ES5	1.48
E10	ES10	2.30
E20	ES20	3.65
E30	ES30	5.79
E40	ES40	8.85
E50	ES50	12.14
E60	ES60	19.84
E70	ES70	35.12
E80	ES80	62.70
E100	NA	135
E120	NA	270
E140	NA	540

**OR**

1. Calculate operating torque  $\left( \frac{63,000 \times HP}{RPM} \right)$
2. Multiply operating torque by service factor obtained from table on page 15.
3. Select coupling size from Table 2 with a capacity equal to or greater than determined in step 2.
4. Follow steps 5 and 6 above.

**Table 2**

Torque Capacity			
Size	Continuous Torque (in. Lbs.)	Size	Continuous Torque (in. Lbs.)
2	190	40	5,500
3	365	50	7,650
4	550	60	12,500
5	925	70	22,125
10	1,450	80	39,500
20	2,300	100	85,050
30	3,650	120	170,100
		140	340,200

## Service Factors

SERVICE FACTORS are means of classifying different equipment and applications into various load classifications. Due to variations in application of equipment, service factors are used to adjust equipment ratings to accommodate for variable loading conditions. This is a general guide. More specific factors are given on page 15.

	Load Classifications	Service Factors
	Continuous service and running loads vary only slightly.	1.0
	Torque loading varies during operation of the equipment.	1.5
	Torque loading varies during operation, frequent stop/start cycles are encountered.	2.0
	For shock loading and substantial torque variations.	2.5
	For heavy shock loading or light reversing drives.	3.0
	Reversing torque loads do not necessarily mean reversal of rotation. Depending upon severity of torque reversal, such loads must be classified between "medium" and "extreme".	Consult Rexnord

### Omega Element Temperature Range (Ambient)

-40°F	+200°F
to	
-40°C	+93°C

### High Temperature Service Factor Adjustment\*

Ambient Temp.	S.F. Adjust.
+150°F (66°C)	+0.25
+165°F (74°C)	+0.50
+180°F (82°C)	+0.75
+200°F (93°C)	+1.00

\* In general, the service factor adjustment for high temperature is in addition to the service factor consideration for the driver and driven equipment. However, if high temperatures are typical for a specific application, maximum temperature consideration is incorporated into the "typical" service factor listing on page E-15. I.E. Steel mill runout tables.

## TYPICAL SERVICE FACTORS\* — MOTOR DRIVEN EQUIPMENT

General Applications	Typical Service Factor	Industry Applications (cont'd)	Typical Service Factor
<b>AGITATORS</b>		<b>FOOD INDUSTRY</b>	
Vertical and Horizontal Screw Propeller, Paddle.....	1.5	Bottle and Can Filling.....	1.0
<b>BLOWERS</b>		Cereal Cooker.....	1.0
Centrifugal.....	1.0	Dough Mixer, Meat Grinder.....	2.0
Lobe or Vane.....	1.5	<b>LUMBER INDUSTRY</b>	
<b>CAR DUMPER AND PULLER</b> .....	2.0	Band Resaw, Circular Resaw.....	2.0
<b>CLARIFIER OR CLASSIFIER</b> .....	1.0	Edger, Head Rig, Hog, Log Haul.....	2.5
<b>COMPRESSORS</b>		Planer.....	2.0
Centrifugal.....	1.0	Rolls, Non-Reversing.....	2.0
Rotary, Lobe or Vane.....	2.0	Rolls, Reversing.....	2.5
Rotary, Screw.....	1.25	Sawdust Conveyor.....	1.5
Reciprocating.....	**	Slab Conveyor, Sorting Table.....	2.0
<b>CONVEYORS</b>		<b>OIL INDUSTRY</b>	
Apron, Assembly, Belt, Chain Flight, Oven.....	1.5	Chiller.....	1.0
Reciprocating.....	**	<b>POWER INDUSTRY</b>	
Screw.....	1.25	Ash Handling Conveyors.....	1.5
<b>CRANES AND HOISTS</b>		Baghouse Air Handling Fans.....	1.5
Main Hoist — Medium Duty.....	2.0	Ball Mill.....	2.5
Main Hoist — Heavy Duty.....	2.5	Belt Conveyors.....	1.5
Skip Hoist.....	2.0	Circulating Pumps (centrifugal).....	1.0
Bridge, Travel or Trolley.....	2.0	Coal Grinders and Crushers.....	2.5
<b>DREDGES</b>		Coal Pulverizers and Hammermills.....	2.5
Cable Reel, Conveyor.....	2.0	Cooling Tower Fans.....	2.0
Cutter Head Drive, Jig Drive.....	3.0	FGD Slurry Pumps (centrifugal).....	1.0
Pump, Screen, Drive, Stackler, Utility Winch.....	2.0	Forced Draft Fan and Induced Draft Fan.....	1.5
<b>DYNAMOMETER</b> .....	1.0	Primary Air, Recycling Fans.....	1.5
<b>ELEVATORS</b>		Traveling Water Screens.....	1.0
Bucket, Freight.....	2.5	<b>PULP &amp; PAPER MILLS</b>	
<b>EXCITER, GENERATOR</b> .....	1.0	Agitator.....	1.5
<b>EXTRUDER, PLASTIC</b> .....	2.0	Barking Drum.....	3.0
<b>FANS</b>		Beater and Pulper.....	2.0
Centrifugal.....	1.0	Bleacher.....	1.0
Cooling Tower.....	2.0	Calendar.....	2.5
Forced Draft and Induced Draft.....	1.5	Chipper.....	3.5
Large Mine.....	2.0	Couch, Cylinder Dryer.....	2.0
Propeller.....	1.5	Felt Stretcher.....	1.0
<b>GENERATORS</b>		Fourdrinier.....	2.0
Even Load.....	1.0	Jordan.....	2.5
Hoist or Railway Service.....	2.0	Press.....	2.5
Welder Load.....	2.5	Pulp Grinder.....	2.5
<b>PRINTING PRESS</b> .....	2.0	Stock Chest.....	1.5
<b>PUMPS</b>		Stock Pump	
Centrifugal.....	1.0	Centrifugal.....	1.0
Positive Displacement.....	1.5	Reciprocating.....	2.5
Rotary — Gear, Lobe, Vane.....	1.5	Rotary.....	2.0
Reciprocating.....	**	Suction Roll.....	2.5
Progressive Cavity.....	1.25	Winder.....	2.0
Peristaltic.....	1.5	<b>RUBBER INDUSTRY</b>	
<b>SCREENS</b>		Banbury Mixer.....	3.0
Air Washing.....	3.0	Calendar.....	2.5
Grizzly.....	1.0	Cracker, Mix Mill, Plasticator Refiner, Sheeter, Tire Building Machine.....	2.0
Coal and Sand (Rotary).....	2.0	Tire and Tube Press Opener.....	1.0
Vibrating.....	5.0	Tuber and Strainer.....	2.0
<b>SEWAGE DISPOSAL EQUIPMENT</b> .....	1.5	Warming Mill.....	2.5
<b>STOKER</b> .....	1.5	Washer.....	3.0
<b>Industry Applications</b>	<b>Typical Service Factor</b>	<b>STEEL INDUSTRY</b>	
<b>AGGREGATE PROCESSING, CEMENT</b>		Coilers.....	2.0
Concrete Mixers.....	2.0	Draw Benches.....	2.0
Crushers, Ore or Stone.....	3.0	Edger Drives.....	2.0
Dryer, Rotary.....	2.0	Reel Drives.....	2.0
Grizzly.....	3.0	Runout Tables (Non-Reversing).....	3.0
Hammermill.....	2.5	Runout Tables (Reversing).....	4.5
Mining Kilns.....	2.5	Soaking Pit Cover Drives.....	3.0
Tube, Rod and Ball Mills.....	2.5	Tube Conveyor Rolls.....	2.5
Tumbling Mill or Barrel.....	2.0	Wire Drawing.....	2.0
<b>BREWERY AND DISTILLING</b>		<b>TEXTILE MILLS</b>	
Bottling and Can Filling Machinery, Brew Kettle, Cooker, Mash Tub.....	1.0	Batcher, Calendar, Card Machine, Dry Can.....	2.0
Scale Hopper (frequent peaks).....	2.0	Dyeing Machinery.....	1.0
		Loom.....	2.0
		Mangle, Napper, Soaper.....	1.5
		Spinner, Tenter Frame.....	2.0

\* The service factors listed are intended only as a general guide and for smooth power sources such as electric motors. For reciprocating prime movers, such as diesel or gas engines, add the following to the service factor:  
 For 8 or more cylinders, add 0.5  
 For 6 cylinders, add 1.0  
 For 4 cylinders, add 1.5  
 For less than 4 cylinders, consult Rexnord  
 If both driver and driven equipment are reciprocating, consult Rexnord.  
 Add 0.5 to service factor if drive is a hydraulic motor.  
 Omega couplings are not recommended for turbine drives if the coupling cannot be protected from steam leakage or from speeds in excess of the coupling's published speed rating (pages E-4 - E-7).  
 \*\* Consult Rexnord Engineering

**IMPORTANT NOTE** — The coupling selection criteria provided is intended for the determination of the coupling size and style only. It is also recommended that the system be analyzed for torsional and lateral stability using the specific coupling mass-elastic data available from Rexnord. This analysis is the responsibility of the user since the coupling is only a single component in the system.

**CAUTION** — In drive systems sensitive to axial movement (i.e., sleeve bearing equipment), it may be necessary to limit axial force and/or displacement. Consult Rexnord for proper installation procedure.

# COUPLING SELECTION



## BORE RANGES

Hub Size	Straight Bore				Taper-Lock® ①			QD ①		
	Min. Bore ②		Max. Bore		Bushing Number	Minimum Bore	Maximum Bore ③	Bushing Number	Minimum Bore	Maximum Bore
	STD	STL	STD	STL ④						
2	1/2	No Min.	1-1/8	1-3/16	N/A			N/A		
3	1/2	3/8	1-3/8	1-3/8	1008	1/2	1	N/A		
4	1/2	3/8	1-5/8	1-3/4	1008	1/2	1	JA	3/8	1-1/4
5	1/2	3/8	1-7/8	1-15/16	1108	1/2	1	SH	1/2	1-11/16
10	1/2	3/8	2-1/8	2-1/4	1310	1/2	1-3/8	SDS	1/2	2
20	3/4	3/4	2-3/8	2-3/4	1610	1/2	1-5/8	SK	1/2	2-1/2
30	3/4	3/4	2-7/8	3-1/4	2012	1/2	2	SF	1/2	2-13/16
40	3/4	3/4	3-3/8	3-3/4	2517	1/2	2-1/2	E	7/8	3-1/2
50	1-1/8	1-1/8	3-5/8	4	2517	1/2	2-1/2	E	7/8	3-1/2
60	1-1/8	1-1/8	4	4-1/2	3020	15/16	3	F	1	3-15/16
70	1-3/8	1-3/8	4-1/2	4-7/8	3535	1-3/16	3-1/2	J	1-7/16	4-1/2
80	1-7/8	1-7/8	6	6-3/4	4040	1-7/16	4	M	1-15/16	5-1/2
100	1-7/8	1-7/8	6-3/4	7-1/4	4545	1-15/16	4-1/2	M	1-15/16	5-1/2
120	1-7/8	1-7/8	7-1/2	8-1/4	5050	2-5/16	5	N	2-7/16	6
140	1-7/8	1-7/8	9	9-1/4	7060	4-9/16	7	P	2-15/16	7

① Bushings are not included with bushed hubs. Bushing bore ranges may vary, check with bushing manufacturer.

② Rough bores are slightly undersized to conform with minimum bore specifications.

④ With shallow keyway.

® TAPER-LOCK® is the registered trademark of Reliance Electric Company.

Note: Hub Material Specifications:

STD - High strength sintered steel (sizes #2-#10) and cast iron (sizes #20 and above).

STL - Low carbon steel

## REX OMEGA® COUPLINGS INTERCHANGE\*

Omega	Dodge Para-Flex	Lovejoy (Rubber)	TB Woods (Rubber)	Falk Grid			Kop-Flex Gear
				1000T	T	F	
2		L-095	5	1020T	20T	3	1H
3		L-099, L-100	6	1030T	30T	4	1H
4		L-110	7	1040T	40T	4	1H
5	50	L-110	8	1040T, 1050T	40T, 50T	5, 6	1H, 1-1/2H
10	60	L-150, L-190	9	1050T, 1060T	50T, 60T	7, 8	1-1/2H
20	70	L-225	10	1060T, 1070T	60T, 70T	8, 9	1-1/2, 2H
30	80	L-276	11	1070T, 1080T	70T, 80T	9, 10	2H, 2-1/2H
40	90		12	1090T	90T	10	2-1/2H
50	110			1090T	90T	11	2-1/2H
60	120		13	1090T	90T	11	2-1/2H
70	140		14	1100T	100T	13	3H
80	160		16	1110T	110T	14	3H
100	200		NA	1120T	120T	15	**
120	240		NA	1130T, 1140T	130T, 140T	16, 17	**
140	280		NA	1150T	150T	18	**

\* **CAUTION** should be applied when using any interchange chart (particularly with respect to gear and grid couplings) since each product has different dimensions, benefits, and service factor recommendations. This interchange is based on typical specifications for centrifugal pump applications at 1750 RPM. For specific applications, consult Rexnord or refer to page E-14 or ask for our Free Slide Selector. Use this chart only as a general guide.

\*\* Consult Rexnord.

Note: Dimensions subject to change. Certified drawings of ordered material furnished on request.



# COUPLING SELECTION



## BORE RANGES

Hub Size	Straight Bore				Taper-Lock® ①			QD ①		
	Min. Bore ②		Max. Bore		Bushing Number	Minimum Bore	Maximum Bore ③	Bushing Number	Minimum Bore	Maximum Bore
	STD	STL	STD	STL ④						
2	1/2	No Min.	1-1/8	1-3/16	N/A			N/A		
3	1/2	3/8	1-3/8	1-3/8	1008	1/2	1	N/A		
4	1/2	3/8	1-5/8	1-3/4	1008	1/2	1	JA	3/8	1-1/4
5	1/2	3/8	1-7/8	1-15/16	1108	1/2	1	SH	1/2	1-11/16
10	1/2	3/8	2-1/8	2-1/4	1310	1/2	1-3/8	SDS	1/2	2
20	3/4	3/4	2-3/8	2-3/4	1610	1/2	1-5/8	SK	1/2	2-1/2
30	3/4	3/4	2-7/8	3-1/4	2012	1/2	2	SF	1/2	2-13/16
40	3/4	3/4	3-3/8	3-3/4	2517	1/2	2-1/2	E	7/8	3-1/2
50	1-1/8	1-1/8	3-5/8	4	2517	1/2	2-1/2	E	7/8	3-1/2
60	1-1/8	1-1/8	4	4-1/2	3020	15/16	3	F	1	3-15/16
70	1-3/8	1-3/8	4-1/2	4-7/8	3535	1-3/16	3-1/2	J	1-7/16	4-1/2
80	1-7/8	1-7/8	6	6-3/4	4040	1-7/16	4	M	1-15/16	5-1/2
100	1-7/8	1-7/8	6-3/4	7-1/4	4545	1-15/16	4-1/2	M	1-15/16	5-1/2
120	1-7/8	1-7/8	7-1/2	8-1/4	5050	2-5/16	5	N	2-7/16	6
140	1-7/8	1-7/8	9	9-1/4	7060	4-9/16	7	P	2-15/16	7

① Bushings are not included with bushed hubs. Bushing bore ranges may vary, check with bushing manufacturer.

② Rough bores are slightly undersized to conform with minimum bore specifications.

④ With shallow keyway.

® TAPER-LOCK® is the registered trademark of Reliance Electric Company.

Note: Hub Material Specifications:

STD - High strength sintered steel (sizes #2-#10) and cast iron (sizes #20 and above).

STL - Low carbon steel

## REX OMEGA® COUPLINGS INTERCHANGE\*

Omega	Dodge Para-Flex	Lovejoy (Rubber)	TB Woods (Rubber)	Falk Grid			Kop-Flex Gear
				1000T	T	F	
2		L-095	5	1020T	20T	3	1H
3		L-099, L-100	6	1030T	30T	4	1H
4		L-110	7	1040T	40T	4	1H
5	50	L-110	8	1040T, 1050T	40T, 50T	5, 6	1H, 1-1/2H
10	60	L-150, L-190	9	1050T, 1060T	50T, 60T	7, 8	1-1/2H
20	70	L-225	10	1060T, 1070T	60T, 70T	8, 9	1-1/2, 2H
30	80	L-276	11	1070T, 1080T	70T, 80T	9, 10	2H, 2-1/2H
40	90		12	1090T	90T	10	2-1/2H
50	110			1090T	90T	11	2-1/2H
60	120		13	1090T	90T	11	2-1/2H
70	140		14	1100T	100T	13	3H
80	160		16	1110T	110T	14	3H
100	200		NA	1120T	120T	15	**
120	240		NA	1130T, 1140T	130T, 140T	16, 17	**
140	280		NA	1150T	150T	18	**

\* **CAUTION** should be applied when using any interchange chart (particularly with respect to gear and grid couplings) since each product has different dimensions, benefits, and service factor recommendations. This interchange is based on typical specifications for centrifugal pump applications at 1750 RPM. For specific applications, consult Rexnord or refer to page E-14 or ask for our Free Slide Selector. Use this chart only as a general guide.

\*\* Consult Rexnord.

Note: Dimensions subject to change. Certified drawings of ordered material furnished on request.



# BORE SPECIFICATIONS

Couplings will be bored in accordance with AGMA Standard 9002-A86 for flexible couplings. Finished bore hubs will be Class 1 clearance fit unless otherwise specified.

## Bore Sizes

Shaft Dia.	Class 1 Clearance Fit	Interference Fit <sup>ⓐ</sup>	Shaft Dia.	Class 1 Clearance Fit	Interference Fit <sup>ⓐ</sup>
1/2	.500-.501	.4990-.4995	2 3/8	2.3750-2.3765	2.373-2.374
5/8	.625-.626	.6240-.6245	2 1/2	2.5000-2.5015	2.498-2.499
3/4	.750-.751	.7490-.7495	2 5/8	2.6250-2.6265	2.623-2.624
7/8	.875-.876	.8740-.8745	2 3/4	2.7500-2.7515	2.748-2.749
1	1.000-1.001	.9990-.9995	2 7/8	2.8750-2.8765	2.873-2.874
1 1/8	1.125-1.126	1.1240-1.1245	3	3.0000-3.0015	2.998-2.999
1 1/4	1.250-1.251	1.2490-1.2495	3 1/4	3.2500-3.2515	3.2470-3.2485
1 3/8	1.375-1.376	1.3740-1.3745	3 1/2	3.5000-3.5015	3.4970-3.4985
1 1/2	1.500-1.501	1.4990-1.4995	3 5/8	3.6250-3.6265	3.6220-3.6235
1 5/8	1.625-1.626	1.623-1.624	3 3/4	3.7500-3.7515	3.7470-3.7485
1 3/4	1.750-1.751	1.748-1.749	4	4.0000-4.0015	3.9970-3.9985
1 7/8	1.875-1.876	1.873-1.874	4 1/2	4.500-4.502	4.4965-4.4980
2	2.000-2.001	1.998-1.999	5	5.000-5.002	4.9965-4.998
2 1/8	2.1250-2.1265	2.123-2.124	5 1/2	5.500-5.502	5.4960-5.4975
2 1/4	2.2500-2.2515	2.248-2.249	6	6.000-6.002	5.9960-5.9975

ⓐ Steel hub material is recommended for interference fit application. Consult Rexnord for unlisted sizes or bores over 6-inch diameter.

Nominal Shaft Diameter		Keyway			Setscrew Dia. Class 2B NC Thread	Recommended Tightening Torque (In. Lbs.)
		Width	Depth			
Over	Thru		Sq.	Rect.		
5/16	7/16	3/32	3/64	...	1/4 - 20	87
7/16	9/16	1/8	1/16	3/64		
9/16	7/8	3/16	3/32	1/8		
7/8	1 1/4	1/4	1/8	3/32	3/8 - 16*	290
1 1/4	1 3/8	5/16	5/32	1/8		
1 3/8	1 3/4	3/8	3/16	1/8		
1 3/4	2 1/4	1/2	1/4	3/16	1/2 - 13**	620
2 1/4	2 3/4	5/8	5/16	7/32		
2 3/4	3 1/4	3/4	3/8	1/4		
3 1/4	3 3/4	7/8	7/16	5/16	3/4 - 10	2400
3 3/4	4 1/2	1	1/2	3/8		
4 1/2	5 1/2	1 1/4	5/8	7/16		
5 1/2	6 1/2	1 1/2	3/4	1/2	1 - 8	7200
6 1/2	7 1/2	1 3/4	7/8	3/4		
7 1/2	9	2	1	3/4		

\* Maximum setscrew diameter is 1/4-20 UNC for size #2 hub.  
 \*\* Maximum setscrew size for hub sizes #3 thru #10 is 3/8-16 UNC.

## FINISHED STOCK BORE HUBS<sup>ⓐ</sup>

(STRAIGHT BORE HUBS BORED IN ACCORDANCE WITH AGMA STANDARD 9002 - A86 CLASS 1 CLEARANCE FIT)

SIZE BORE	2SHSB		3SHSB		4SHSB		5SHSB		10SHSB		20SHSB		30SHSB		40SHSB		50SHSB		60SHSB	
	STD	STL	STD	STL	STD	STL	STD	STL	STD	STL	STD	STL	STD	STL	STD	STL	STD	STL	STD	STL
5/8	X		X		X															
3/4	X	X	X	X	X	X	X													
7/8	X	X	X	X	X	X	X	X		X										
15/16					X	X	X													
1	X	X	X	X	X	X	X	X		X										
1-1/16					X	X	X													
1-1/8	X	X	X	X	X	X	X	X	X	X	X	X								
1-3/16					X	X	X													
1-1/4			X	X	X	X	X			X		X	X							
1-5/16					X	X	X													
1-3/8			X	X	X	X	X	X	X	X	X	X								
1-7/16					X	X	X			X										
1-1/2					X	X	X	X		X	X	X			X					
1-9/16					X	X	X			X										
1-5/8					X	X	X	X	X	X	X	X	X	X	X	X				
1-11/16							X	X		X	X	X								
1-3/4							X	X	X	X	X	X			X		X			
1-7/8							X	X	X	X	X	X	X	X	X	X	X			
1-15/16								X	X	X	X									
2								X	X	X	X	X	X							X
2-1/8								X	X	X	X	X	X	X			X			X
2-3/16										X										
2-1/4										X		X		X		X				
2-3/8										X	X	X	X	X	X	X				X
2-1/2											X		X							
2-11/16											X		X							
2-3/4											X	X	X	X						
2-7/8											X	X	X	X			X			X
3-5/16																	X			X
3-3/8															X	X	X			X

ⓐ Hub Material Specifications:  
 STD - Cast iron  
 STL - Low carbon steel

# ORDERING INSTRUCTIONS



## STANDARD AND SPACER COUPLINGS

When ordering a complete coupling, specify size/type of element and hubs (two hubs per complete coupling) options include:

### Element

- [ E2 - E140] standard (close coupled)
- [ ES2 - ES80] spacer

### Hub

- [ 2SHRB - 140SHRB] straight hub-rough bore
- [ 2SHSB - 60SHSB] straight hub-stock bore (specify bore size from table on page E-17)
- [ 2SHCB - 140SHCB] straight hub-custom bore (specify bore & keyway)
- [ 4HQD - 140HQD] hub-QD (bushing not included)
- [ 3HTL - 140HTL] hub-TAPER-LOCK® (bushing not included)
- [ 10SHMM - 140SHMM] straight hub-mill motor (specify mill motor number, rough or custom bore)

**NOTE:** Specify hub material; standard or steel after hub description (see price book for options/availability).  
 ® TAPER-LOCK® is the registered trademark of Reliance Electric Company.

### Order example:

Complete #50 standard (close coupled) coupling with one finished bore 2-1/8" iron hub w/standard keyway and one QD hub less bushing. Order description:

- 1 ea. E50 element
- 1 ea. 50SHSB — 2-1/8" — std.
- 1 ea. 50HQD — steel

### Other Available Designs:

#### Sleeve Extensions

- [3SE - 120SE]

#### Floating Piloted Shaft Couplings

- [10FTA-140FTA] specify bore, shaft spacing & material class
- [10PSA-140PSA] specify bore, shaft spacing & material class
- [10FSA-140FSA] specify bore, shaft spacing & material class

## TAPERED BORES

### Information Required

- Drawing of HUB showing complete bore and keyway details.  
— OR —
- Drawing of SHAFT with dimensions shown below, allowing Rexnord to bore hubs to suit.

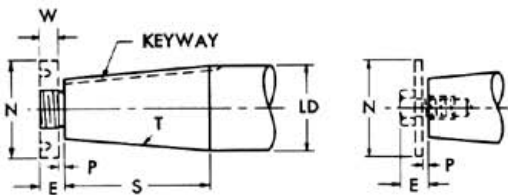

- (LD) Large Diameter, Specify in Decimals.
- (S) Length of Taper, Measure parallel to Shaft centerline.
- (T) Taper per Foot, Difference in Diameter in one foot length.
- (P) Clearance space for drawing Hub up on tapered shaft. Usually 1/8" or 1/4", depending on shaft size and taper.

Keyway: Width, Depth.

Note: Specify if keyway is parallel to Taper or if parallel to shaft center line.

Specify depth at larger diameter of Taper if keyway is parallel to shaft center line.

### Supplemental Taper Bore Information

With connected equipment in fixed position, the following additional information is necessary:

Dimensions "V" and "X" must be given when one or both connected machines are fixed on their bases. Advise if dimension "X" is fixed, or if variable between what limits.

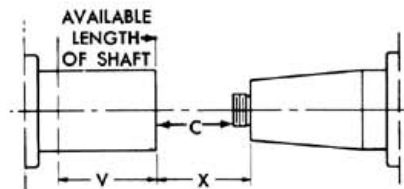

A fixed "X" dimension may require altered or special coupling hubs. Often the straight bored hub can be positioned on its shaft allowing the use of a standard coupling. See illustrations below.

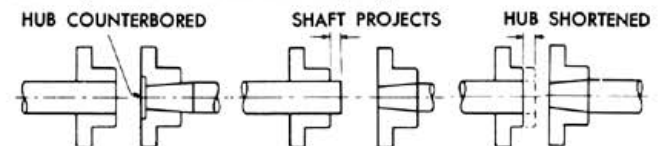

Consult A.G.M.A. Standard 9002-A86 "Taper Bores for Flexible Couplings" for new applications.



## World Class Customer Service

For over 100 years the dedicated people of Rexnord have delivered excellence in quality and service to our customers around the globe. Rexnord is a trusted name when it comes to providing skillfully engineered products that improve productivity and efficiency for industrial applications worldwide. We are committed to exceeding customer expectations in every area of our business: product design, application engineering, operations and customer service.

Because of our customer focus, we are able to more thoroughly understand the needs of your business and have the resources available to work closely with you to reduce maintenance costs, eliminate redundant inventories and prevent equipment down time.

Rexnord represents the most comprehensive portfolio of power transmission and conveying components in the world with the brands you know and trust.

# The Power of Rexnord™



FLATTOP

BEARINGS

GEARED  
PRODUCTSINDUSTRIAL  
CHAIN

COUPLINGS

AEROSPACE

SPECIAL  
COMPONENTS<sup>4</sup>

## WORLDWIDE CUSTOMER SERVICE

### AUSTRALIA

Rexnord Australia Pty. Ltd.  
Picton, New South Wales  
Phone: 61.2.4677.3811  
Fax: 61.2.4677.3812

### BRAZIL

Rexnord Correntes Ltda.  
Sao Leopoldo - RS  
Phone: 55.51.579.8022  
Fax: 55.51.579.8029

### CANADA

Rexnord Canada Ltd.  
Scarborough, Ontario  
Phone: 1.416.297.6868  
Fax: 1.416.297.6873

### CHINA

Rexnord China  
Shanghai, China  
Phone: 86.21.62701942  
Fax: 86.21.62701943

### EUROPE

Rexnord NV/SA  
Mechelen, Belgium  
Phone: 32.70.22.33.66  
Fax: 32.70.22.33.67

Rexnord Kette GmbH  
Betzdorf, Germany  
Phone: 49.2741.2840  
Fax: 49.2741.284.385

### LATIN AMERICA

Rexnord International, Inc.  
Milwaukee, Wisconsin  
Phone: 1.414.643.3000  
Fax: 1.414.643.3222

### MEXICO

Rexnord S.A. de C.V.  
Queretaro, Qro.  
Phone: 52.442.218.5000  
Fax: 52.442.218.1090

### SINGAPORE

Rexnord International, Inc.  
Singapore City, Singapore  
Phone: 65.6338.5622  
Fax: 65.6338.5422

### UNITED STATES

Eastern Service Center  
Atlanta, Georgia  
Phone: 1.770.431.7200  
Fax: 1.770.431.7299

Central Service Center  
Grove City, Ohio  
Phone: 1.614.675.1800  
Fax: 1.614.675.1898

Southern Service Center  
Arlington, Texas  
Phone: 1.817.385.2800  
Fax: 1.817.385.2873



Rexnord Coupling Group  
5555 South Moorland Road  
New Berlin, Wisconsin 53151  
Phone: 1.800.767.3539 Fax: 1.262.796.4064  
Visit us on-line at [www.rexnord.com](http://www.rexnord.com)