

Gearflex Couplings



RENOLD
Superior Coupling Technology

www.renold.com

RENOLD

Strength through Service

Renold Gears has been manufacturing high quality, high specification gear units for over 100 years and has always been at the leading edge of gear technology with innovative products and power transmission solutions.

Interchangeability

Many of the products from Renold Gears are dimensionally interchangeable with other manufacturers gear units, allowing a trouble free replacement of gearboxes, in most cases upgrading the capacity through state of the art technology and materials.

Custom Made

Renold Gears is unique in it's ability to offer custom made products designed to meet customers exacting requirements without compromise on availability and cost. From complete package solutions to individual precision replacement gears, all can be tailor made to meet specific applicational requirements.

Available

The most popular ranges of gearboxes are available from local distribution stock, backed up by extensive stocks from our manufacturing plant in the UK.

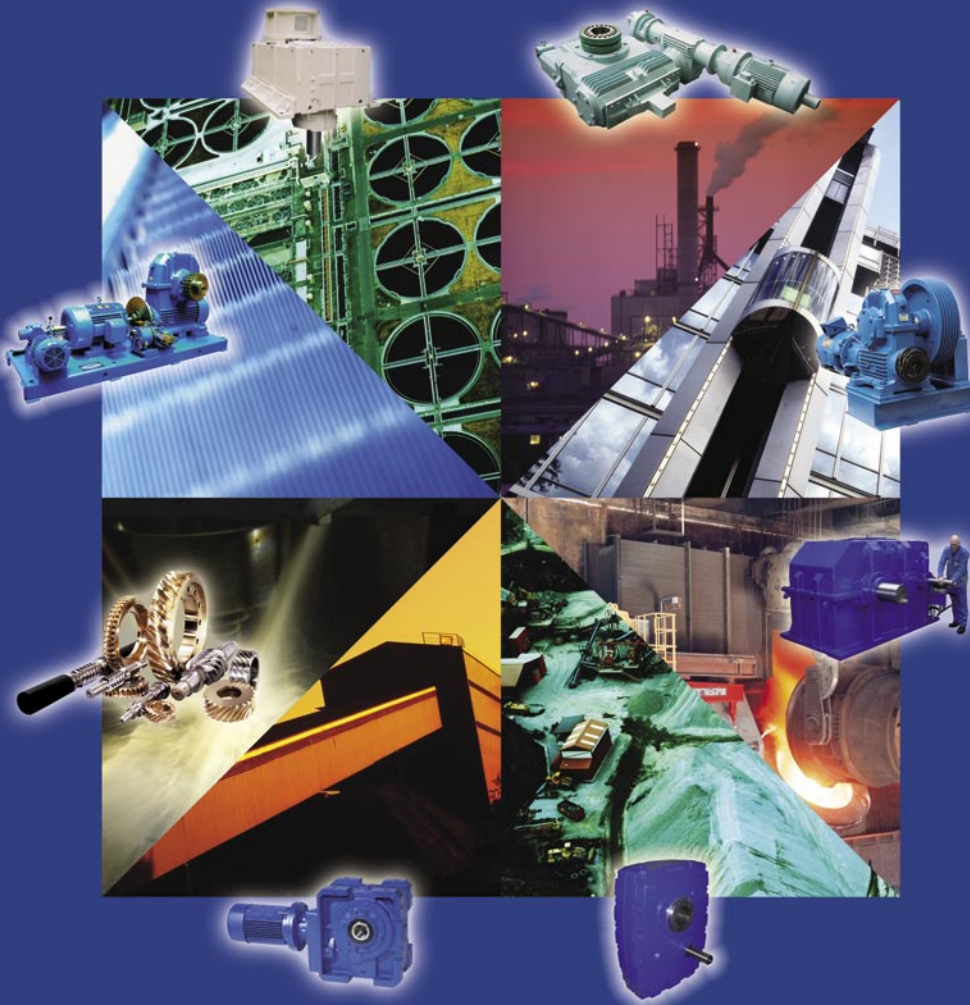

RENOLD

Superior Gear Technology

www.renold.com

Contents

	<i>Page No</i>
Renold Gears	inside front cover
Gearflex	02
Gearflex Adapted and Custom Gear Couplings	04
Gearflex A series Double Engagement type DA	05
Gearflex Heavy Duty B series Double Engagement type HDB	06
Gearflex A series Single Engagement type SA	07
Gearflex Heavy Duty B series Single Engagement type HSB	08
Gearflex High Misalignment D series Double Engagement type DD	09
Gearflex High Misalignment D series Single Engagement type SD	10
Gearflex High Misalignment D series	11
Gearflex A series Double Engagement Flanged Spacer type DAFS	12
Gearflex Vertical Double Engagement type VA	13
Gearflex High Speed Double Engagement type NTS	14
Gearflex Interchange Information	15
Renold Chain	inside back cover

Gearflex



Renold Gearflex consists of both standard ranges and customised special all metal couplings, giving maximum power capacity within minimum space envelope and excellent misalignment capacity.

Coupling capacity

- Maximum power @ 100RPM: 50485kW
- Maximum torque: 4747000Nm

Features and benefits

- All carbon steel heavy duty gear coupling for strength in application, combined with long life.
- AGMA standard (DA/SA ranges) - interchangeable and cost effective.
- Single and double engagement types available, suiting all applicational requirements.
- Crowned and barrelled teeth for optimum contact and long life.
- Customised options available for all gearflex ranges to give design suitability for demanding applications.
- High misalignment up to 6°

Range options

- A series AGMA standard double and single engagement
- B series heavy duty standard double and single engagement
- D series high misalignment double and single engagement
- V series vertical
- NTS high speed
- A series double engagement flanged spacer (DAFS)
- A series double engagement carbon shaft
- Brake Disc/Drum
- Dis-engaging
- Long Hub
- Croft MB Series
- Mill Motor
- Shear Pin
- Telescopic

Applications

- Crane drives
- Mining
- Steelworks
- General heavy industrial applications

Construction details

Medium carbon steel half bodies and inner hubs.

'O' Ring sealing (A series)

Lip seals (D series)



Standard Gearflex products DA, HDB, SA, HSB and NTS can be certified for use in potentially explosive atmospheres containing gas or dust, according to ATEX directive 94/9/EC. The couplings are classified for equipment group II, categories 2 and 3.

Special conditions apply. Contact Renold for further details, or for consideration of ATEX certification of other Gearflex products.



Misalignment capabilities:

Double Engagement types

- Parallel Offset
- Angular
- Axial (End Float)

Single Engagement types

- Angular
- Axial (End Float)

Designed to meet the demands of today's wide ranging applications and manufactured to Renolds high standards.

Renold Gearflex Couplings feature an increased tooth capacity from optimised design, providing maximised power capacity within a given space envelope.

Contact us for more information on how we can deliver a cost effective solution to your application.

RENOLD Clutches & Couplings have the design and manufacturing capability to engineer a shaft coupling to suit customers special design application requirements.

Note: Croft MB series are also readily available in all variants. For details contact Renold.

When used in conjunction with a cardan shaft, two single engagement couplings will accept offset misalignment.

The amount will be dependant upon the cardan shaft length.

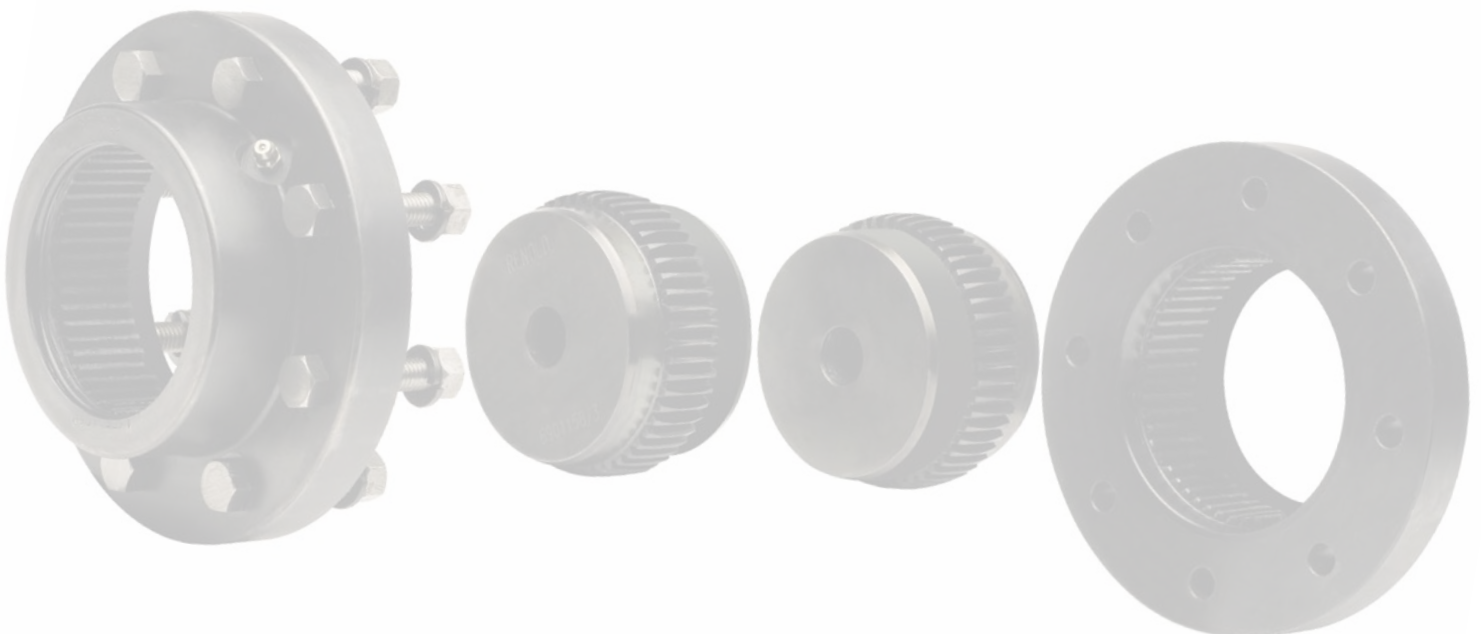

Adapted and Custom Gear Couplings

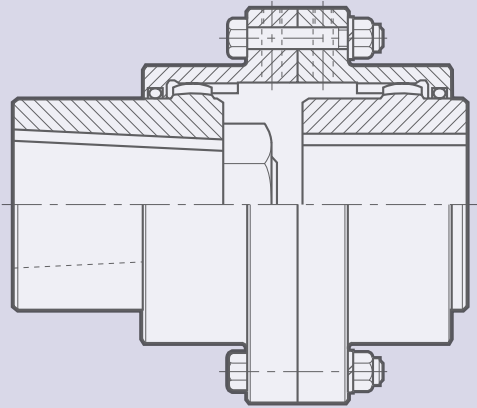

Mill motor gear

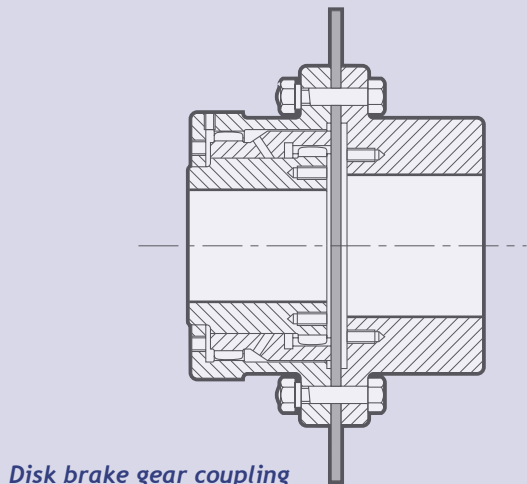
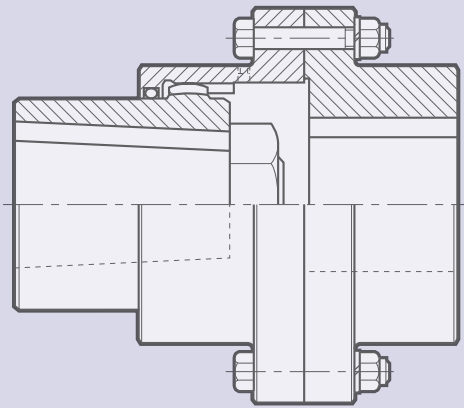

Disk brake gear coupling

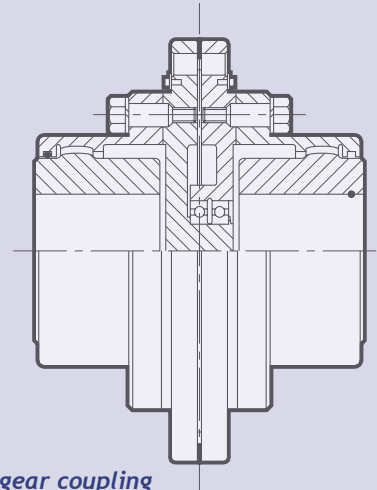

Shear pin gear coupling

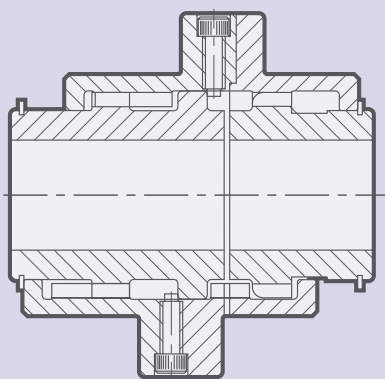

Disengaging type gear coupling - standard series

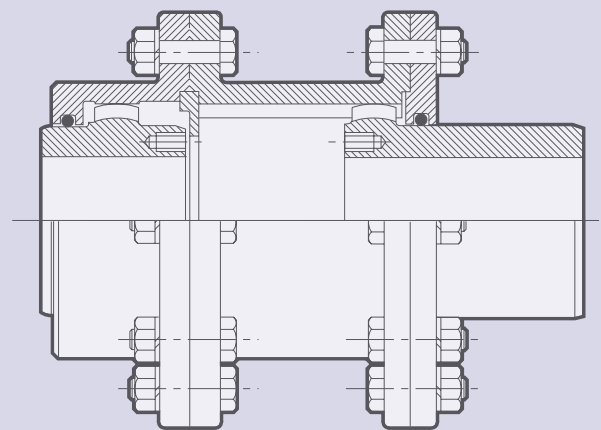

Telescopic type gear coupling - standard series

Gearflex A series Double Engagement type DA

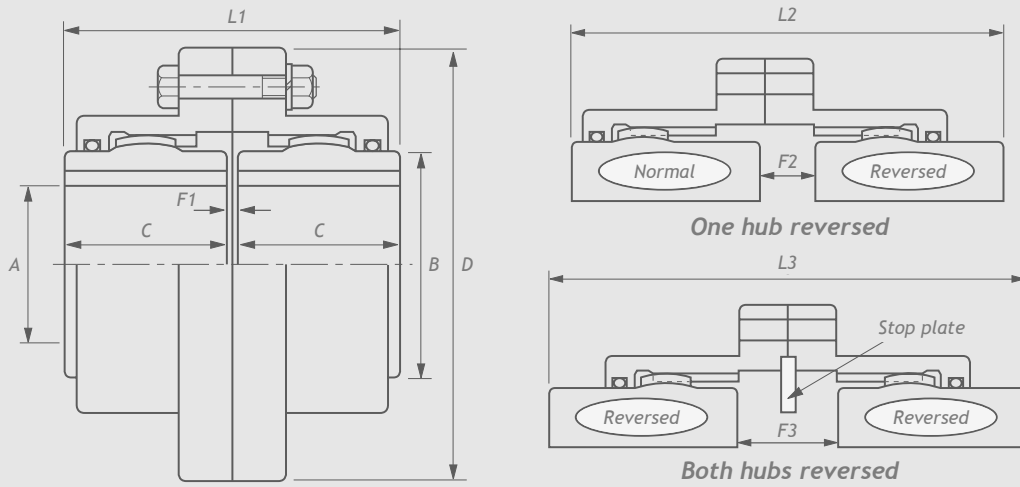

Coupling size	Product no	Power /100rpm kW	Torque nominal Nm	Speed max** rpm	Bore A		Dimensions										Offset max mm	
					Max mm	Min mm	B mm	C mm	D mm	F1 mm	F2 mm	F3 mm	L1 mm	L2 mm	L3 mm	Mass kg		WR ² kg m ²
GF10DA	6901108	14.9	1423	7100	46	14	60	43	116	3	5	6	89	90	92	4.2	0.006	1.2
GF15DA	6901158	28.2	2693	5400	57	20	76	49	152	3	8	13	102	106	111	7.7	0.020	1.5
GF20DA	6901208	48	4584	4800	78	27	102	62	178	3	14	25	127	138	149	15.0	0.044	2.0
GF25DA	6901258	77.6	7411	4250	90	27	117	77	213	5	12	19	159	166	173	25.4	0.105	2.3
GF30DA	6901308	128	12224	4000	110	39	143	91	240	5	23	42	187	206	224	36.7	0.188	3.0
GF35DA	6901358	196	18718	3600	127	39	165	106	279	6	27	48	219	240	260	60.8	0.436	3.5
GF40DA	6901408	312	29796	3290	145	55	191	121	318	6	32	57	248	273	298	90.7	0.822	4.0
GF45DA	6901458	431	41161	2920	165	55	216	135	346	8	37	65	278	306	335	122	1.305	4.5
GF50DA	6901508	578	55199	2630	185	55	241	153	389	8	50	92	314	356	398	178	2.550	5.3
GF55DA	6901558	857	81844	2320	205	55	267	175	425	8	53	98	359	404	449	235	3.780	6.0
GF60DA	6901608	1096	104668	2120	225	55	292	188	457	8	60	111	384	436	487	279	4.860	6.5
GF70DA	6901708	1640	156620	1830	260	55	343	221	527	9	71	133	451	513	575	443	10.350	7.8

Misalignment angle per half (degrees)	Rating factor
1.50	1.00
1.00	1.15
0.75	1.30
0.50	1.55
0.00	2.00

Catalogue ratings shown are nominal values at 1.50 degrees.

For values at misalignments less than 1.50 degrees:-

Multiply nominal catalogue values by factor in table left.

e.g.

GF60DA at 1.50° = 104668 Nm

at 0.75° = 104668 x 1.30:-

GF60DA at 0.75° = 136068 Nm

Long hub versions available. Contact Renold for details.
See key stress calculations on page 13.

* Maximum Bore - The maximum bores shown are absolute maximums.
Under normal circumstances the boss to bore ratio should not be less than 1.5 for standard applications.
Consult Renold for overbore approval.

** Speed in excess of these shown may require additional balancing.

*** Hubs may be reversed to increase DBSE (F2 + F3 above). If axial movement is allowed with both hubs reversed, a stop plate should be fitted to prevent hubs disengaging from outers.

Ordering code

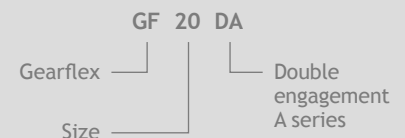

Gearflex Heavy Duty B series Double Engagement type HDB

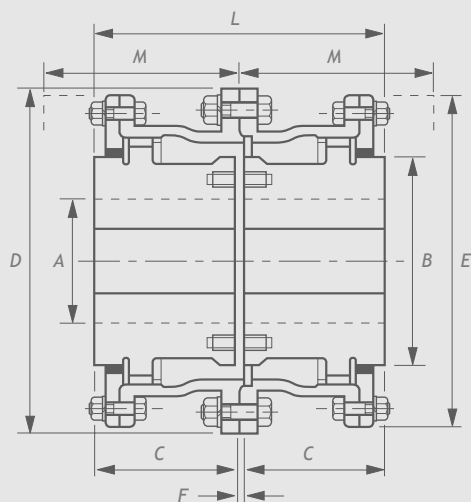

Options

- 1. Loose spigot ring
- 2. Bolt on end plates

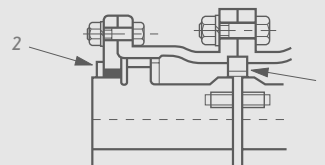

Coupling size	Power /100rpm kW	Torque nominal Nm	Speed max** rpm	Bore A		Dimensions								Max misalignment		Offset float mm
				Max* mm	Min mm	B mm	C mm	D mm	E mm	F mm	L mm	M mm	Mass kg	Offset mm	Angular deg	
GF8HDB	1938	185120	2000	275	115	360	203	533	508	10	416	232	448	3.6	0.75	15.8
GF9HDB	2663	254280	1900	305	140	400	228	584	559	12	468	261	609	4.2	0.75	19.1
GF10HDB	2982	284800	1800	360	140	470	254	660	628	12	520	293	871	4.8	0.75	19.1
GF11HDB	3653	348900	1600	370	150	483	280	711	680	12	572	318	1070	5.3	0.75	19.1
GF12HDB	4846	462800	1400	410	150	533	305	768	737	14	624	343	1391	5.7	0.75	19.1
GF14HDB	7231	690600	1200	465	285	610	356	902	857	18	730	400	1767	6.9	0.75	19.1
GF16HDB	11183	1068000	1000	535	335	699	406	991	946	20	832	457	2560	8.4	0.75	19.1
GF18HDB	16031	1531000	700	605	360	787	457	1124	1073	25	939	520	3485	9.2	0.75	22.1
GF20HDB	22733	2171000	500	665	385	864	483	1230	1180	25	991	560	4463	9.6	0.75	22.1
GF22HDB	31309	2990000	400	720	410	940	483	1308	1257	25	991	560	5358	9.6	0.75	22.1
GF24HDB	37277	3560000	300	780	460	1016	483	1372	1321	25	991	560	6239	9.6	0.75	22.1
GF26HDB	49707	4747000	270	840	540	1092	559	1524	1486	28	1146	650	8985	10.6	0.75	22.1

Misalignment angle per half (degrees)	Rating factor
0.75	1.00
0.50	1.20
0.00	1.60

Catalogue ratings shown are nominal values at 0.75 degrees. For values at misalignments less than 0.75 degrees:- Multiply nominal catalogue values by factor in table left.

Long hub versions available contact Renold for details. See key stress calculations on page 13.

* Maximum Bore - The maximum bores shown are absolute maximums. Under normal circumstances the boss to bore ratio should not be less than 1.5 for standard applications. Consult Renold for overbore approval.

** Speed in excess of these shown may require additional balancing.

Ordering code

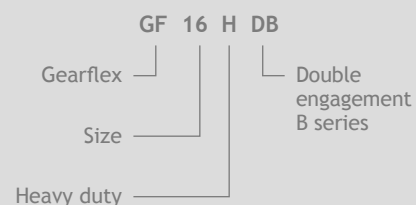

Gearflex A series Single Engagement type SA

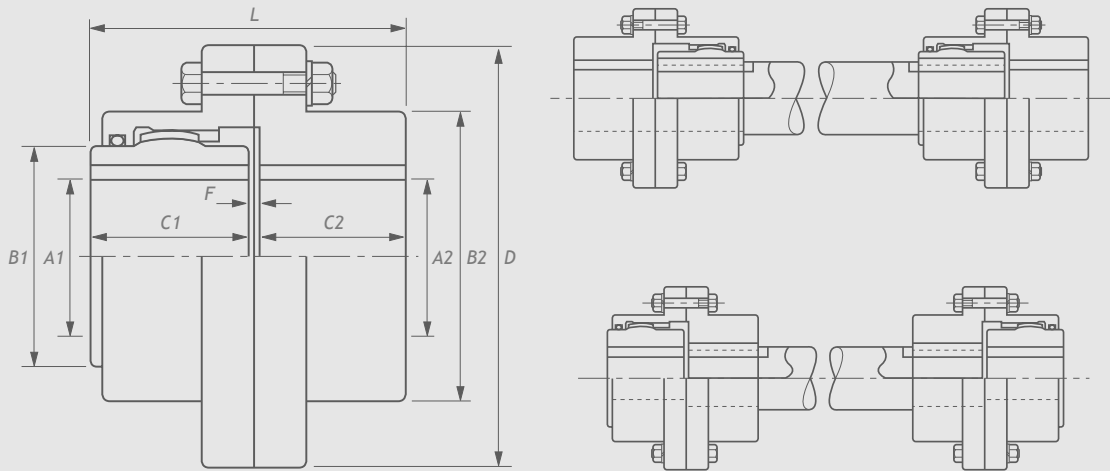

Coupling size	Product no	Power /100rpm kW	Torque nominal Nm	Speed max** rpm	Bore A1		Bore A2		Dimensions								
					Max* mm	Min mm	Max mm	Min mm	B1 mm	B2 mm	C1 mm	C2 mm	D mm	F mm	L mm	Mass kg	WR ² kg m ²
GF10SA	6908108	14.9	1423	7100	46	14	58	14	60	76	43	40	116	4	87	4.8	0.005
GF15SA	6908158	28.2	2693	5400	57	20	75	20	76	98	49	47	152	4	100	8.4	0.019
GF20SA	6908208	48	4584	4800	78	27	95	27	102	124	62	60	178	4	125	17.2	0.044
GF25SA	6908258	77.6	7411	4250	90	27	110	27	117	148	77	75	213	5	156	29.0	0.107
GF30SA	6908308	128	12224	4000	110	39	130	39	143	173	91	89	240	5	185	39.0	0.200
GF35SA	6908358	196	18718	3600	127	39	155	39	165	201	106	104	279	6	216	63.5	0.446
GF40SA	6908408	312	29796	3290	145	55	180	55	191	233	121	116	318	8	244	93.9	0.842
GF45SA	6908458	431	41161	2920	165	55	200	55	216	262	135	130	346	9	274	127	1.350
GF50SA	6908508	578	55199	2630	185	55	225	55	241	294	153	148	389	9	310	186	2.800
GF55SA	6908558	857	81844	2320	205	55	250	55	267	324	175	164	425	9	348	244	3.940
GF60SA	6908608	1096	104668	2120	225	55	265	55	292	349	188	182	457	10	380	299	5.130
GF70SA	6908708	1640	156620	1830	260	55	310	55	343	406	221	221	527	13	454	472	11.040

Misalignment angle gear half (degrees)	Rating factor
1.50	1.00
1.00	1.15
0.75	1.30
0.50	1.55
0.00	2.00

Catalogue ratings shown are nominal values at 1.50 degrees.
For values at misalignments less than 1.50 degrees:-
Multiply nominal catalogue values by factor in table left.

Long hub versions available. Contact Renold for details. See key stress calculations on page 13. Renold can supply cardan shaft or flanged spacer assemblies. Critical speeds must be checked, please contact Renold.

* Maximum Bore - The maximum bores shown are absolute maximums. Under normal circumstances the boss to bore ratio should not be less than 1.5 for standard applications. Consult Renold for overbore approval.

** Speed in excess of these shown may require additional balancing.

Ordering code



Gearflex Heavy Duty B series Single Engagement type HSB

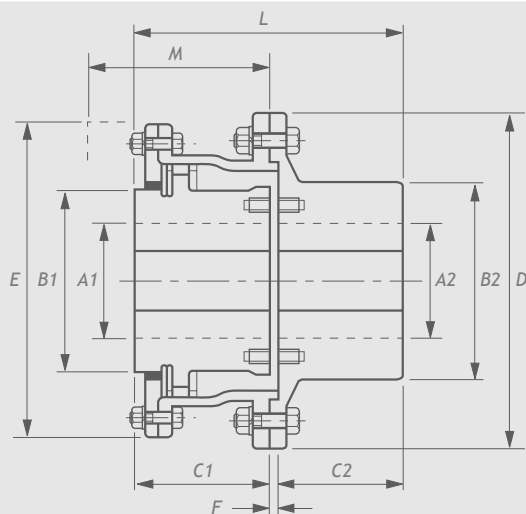

Options

- 1. Loose spigot ring
- 2. Bolt on end plates

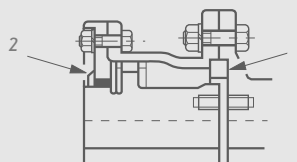

Coupling size	Power /100rpm kW	Torque nominal Nm	Speed max** rpm	Bore A1		Bore A2		Dimensions										Max angular misalignment deg	End float mm
				Max* mm	Min mm	Max mm	Min mm	B1 mm	B2 mm	C1 mm	C2 mm	D mm	E mm	F mm	L mm	M mm	Mass kg		
GF8HSB	1938	185120	2000	275	115	240	115	360	368	203	200	533	508	13	416	232	411	0.75	7.9
GF9HSB	2663	254280	1900	305	140	280	140	400	406	228	226	584	559	14	468	261	557	0.75	9.6
GF10HSB	2982	284800	1800	360	140	305	140	470	457	254	252	660	628	14	520	293	877	0.75	9.6
GF11HSB	3653	348900	1600	370	150	330	150	483	533	280	278	711	680	14	572	318	1051	0.75	9.6
GF12HSB	4846	462800	1400	410	150	356	150	533	584	305	302	768	737	16	623	343	1365	0.75	9.6
GF14HSB	7231	690600	1200	465	285	430	190	610	660	356	354	902	857	21	731	400	1504	0.75	9.6
GF16HSB	11183	1068000	1000	535	335	480	215	699	711	406	405	991	946	21	832	458	2184	0.75	9.6
GF18HSB	16031	1531000	700	605	360	560	255	787	864	457	456	1124	1073	27	940	521	2947	0.75	11
GF20HSB	22733	2171000	500	665	385	610	280	864	940	483	481	1230	1181	27	991	560	3717	0.75	11
GF22HSB	31309	2990000	400	720	410	635	300	940	965	483	481	1308	1257	27	991	560	4436	0.75	11
GF24HSB	37277	3560000	300	780	460	660	330	1016	1016	483	481	1372	1321	27	991	560	5227	0.75	11
GF26HSB	49707	4747000	270	840	540	710	355	1092	1168	559	560	1524	1486	28	1147	650	7993	0.75	11

Misalignment angle gear half (degrees)	Rating factor
0.75	1.00
0.50	1.20
0.00	1.60

Catalogue ratings shown are nominal values at 0.75 degrees. For values at misalignments less than 0.75 degrees:- Multiply nominal catalogue values by factor in table left.

Long hub versions available. Contact Renold for details. See key stress calculations on Page 13. Renold can supply cardan shaft or torque tube assemblies. Critical speeds must be checked, please contact Renold.

* Maximum Bore - The maximum bores shown are absolute maximums. Under normal circumstances the boss to bore ratio should not be less than 1.5 for standard applications. Consult Renold for overbore approval.

** Speed in excess of these shown may require additional balancing.

Ordering code

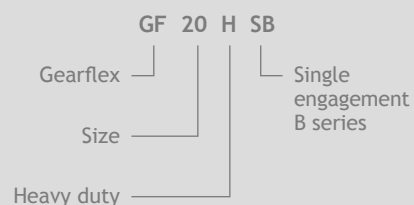

Gearflex High Misalignment D series Double Engagement type DD

D Series Double Engagement couplings accommodate offset, angular or combined misalignment.

Universally used for connecting industrial applications that are subject to higher than standard misalignment of the Gearflex DA, such as oil field equipment and rolling mill drives.

Induction hardened gear teeth and lip type seals handle up to 6° of misalignment.

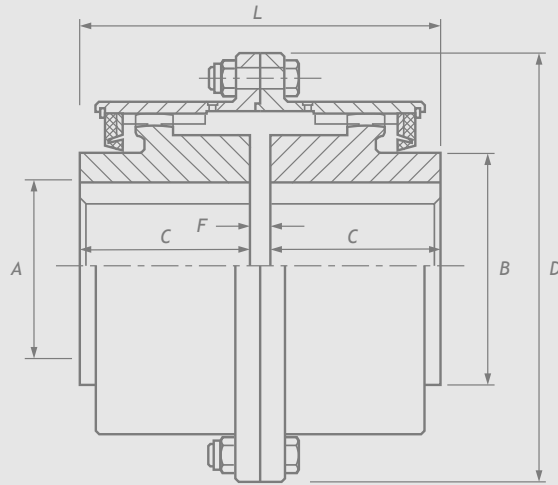

Coupling size	Torque rating Nm	Bore A Max* mm	Dimensions										Mass kg	WR ² kg m ²	Offset (parallel)		
			B at 3.5° mm	B at 6° mm	C at 3.5° mm	C at 6° mm	D mm	F at 3.5° mm	F at 6° mm	L at 3.5° mm	L at 6° mm	misalignment at					
												3.5° mm			6° mm		
GF 100DD		27	44			36		89	5			76		1.9	0.002	2.34	
GF 150DD		41	58	58	56	52.3	152	6	9.5	118	115	8.2	0.018	4.06	6.68		
GF 200DD		54	73	73	70	65	176	8	13	148	148	12.2	0.037	5.13	8.33		
GF 250DD	See table on page 15	67	94	92	78	73	203	10	14	165	160	22.7	0.074	5.79	9.50		
GF 300DD		80	111	109	93	87	229	11	17	197	192	30.5	0.143	6.96	11.40		
GF 350DD		92	127	125	99	94	272	13	18	211	205	47.3	0.325	7.82	12.70		
GF 400DD		105	143	140	113	106	295	14	21	240	233	65	0.503	8.61	14.00		
GF 450DD		118	164	162	122	114	324	16	24	260	252	87.7	0.808	9.50	15.34		
GF 500DD		134	189	186	135	127	375	16	24	286	278	134	2.209	10.44	16.99		
GF 550DD		152	219	214	152	145	416	21	28	325	318	185	2.9	12.40	19.84		
GF 600DD		171	235	232	178	168	457	22	32	378	368	249	4.214	13.94	22.66		
GF 700DD		197	279	273	203	194	518	27	35	433	422	374	8.545	15.60	25.17		

* Maximum Bore - The maximum bores shown are absolute maximums. Under normal circumstances the boss to bore ratio should not be less than 1.5 for standard applications. Consult Renold for overbore approval.

Max speed dependent on misalignment requirement, please consult Renold.

Specify misalignment angle $\pm 3.5^\circ$ or $\pm 6^\circ$.

Gear Teeth are induction hardened.

Shrouded bolt flanges available if required.

Ordering code



Gearflex High Misalignment D series Single Engagement type SD

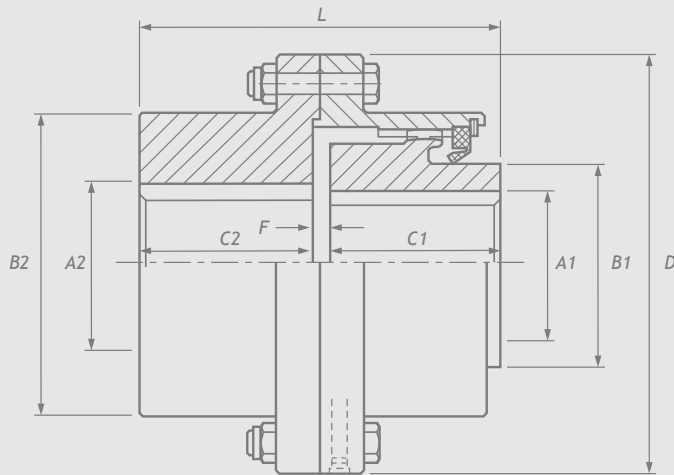

D Series Single Engagement couplings are commonly used in pairs with a floating shaft to connect widely separated equipment, accommodating offset, angular or combined misalignment.

Universally used for pinch roll, shear drives and tension bridles on auxiliary rolling mill equipment.

Coupling size	Torque rating Nm	Bore		Dimensions											Offset (parallel)			
		A1 Max* mm	A2 Max* mm	B1 at 3.5° mm	B1 at 6° mm	B2 mm	C1 at 3.5° mm	C1 at 6° mm	C2 mm	D mm	F at 3.5° mm	F at 6° mm	L at 3.5° mm	L at 6° mm	Mass kg	WR ² kg m ²	misalignment at 3.5° mm	misalignment at 6° mm
GF 100SD		27	43	44		64	36		35	89	5		76		2.27	0.002	2.34	
GF 150SD		41	70	58	58	100	56	52.3	58	152	6	9.5	118	115	9.91	0.19	4.06	6.68
GF 200SD		54	83	73	73	121	70	65	71	176	8	13	148	148	14.5	0.058	5.13	8.33
GF 250SD	See table on page 15	67	96	94	92	140	78	73	78	203	10	14	165	160	24.1	0.098	5.79	9.50
GF 300SD		79	116	111	109	165	93	87	94	229	11	17	197	192	35	0.162	6.96	11.40
GF 350SD		92	135	127	125	194	99	94	103	272	13	18	211	205	53.6	0.351	7.82	12.70
GF 400SD		105	153	143	140	221	113	106	115	295	14	21	240	233	72.7	0.579	8.61	14.00
GF 450SD		118	165	164	162	248	122	114	125	324	16	24	260	252	96.8	0.878	9.50	15.34
GF 500SD		133	190	189	186	276	135	127	137	375	16	24	286	278	146.4	2.119	10.44	16.99
GF 550SD		152	215	219	214	314	152	145	160	416	21	28	325	318	206.8	3.248	12.40	19.84
GF 600SD		171	241	235	232	349	178	168	184	457	22	32	378	368	274.5	4.887	13.94	22.66
GF 700SD		197	225	279	273	403	203	194	216	518	27	35	433	422	422.7	9.716	15.60	25.17

* Maximum Bore - The maximum bores shown are absolute maximums. Under normal circumstances the boss to bore ratio should not be less than 1.5 for standard applications. Consult Renold for overbore approval.

Specify misalignment angle ± 3.5° or ± 6°.

Gear Teeth are induction hardened.

Shrouded bolt flanges available if required.

Offset capacity is dependant on shaft length, please consult Renold for max permissible speeds.

Ordering code



Gearflex High Misalignment D series

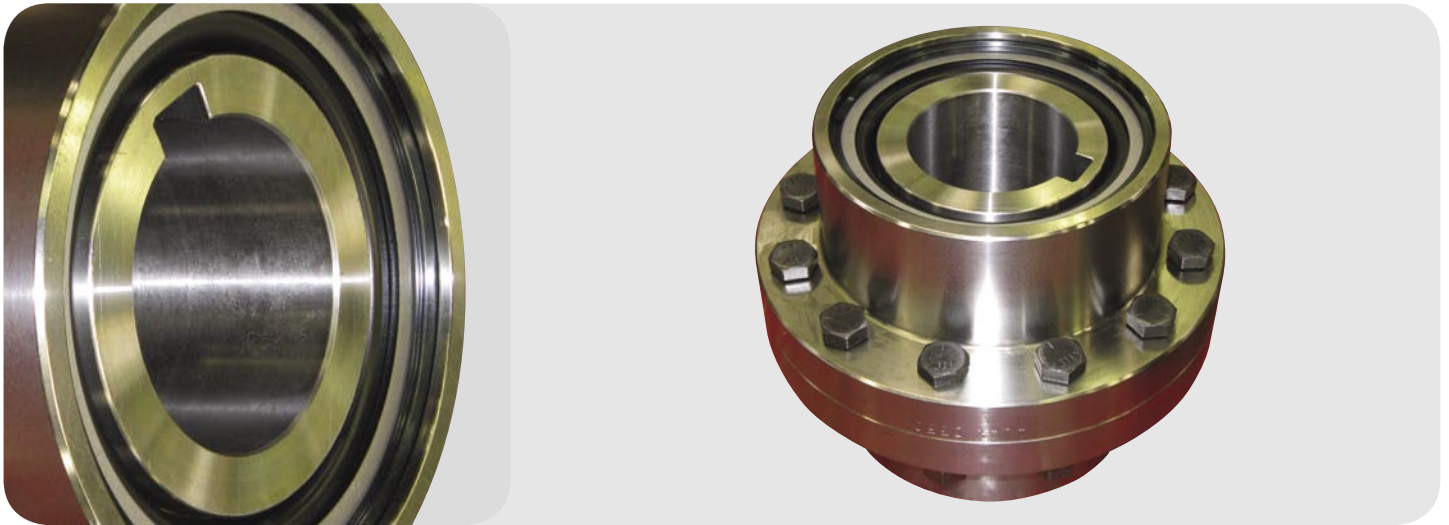

Gearflex D Series Gear Tooth Ratings - Nm*

Maximum misalignment		±3.5° per gear mesh			±6° per gear mesh					
Operating Angle		1°	2°	3°	1°	2°	3°	4°	5°	6°
Coupling Spindle Size	100	847	599	429						
	150	2706	1853	1300	1684	1198	847	599	441	294
	200	4102	2927	2056	2667	1898	1333	949	712	475
	250	9605	6859	4814	5446	3887	2723	1944	1446	972
	300	14237	10169	7141	8056	5763	4045	2881	2147	1435
	350	24237	17322	12158	13774	9853	6915	4915	3684	2463
	400	32373	23130	16237	18395	13141	9232	6576	4915	3288
	450	58452	41763	29322	35379	25277	17751	12633	9446	6316
	500	73198	52294	36723	44305	31650	22226	15819	11830	7910
	550	96633	69040	48475	58486	33480	29333	20881	15616	10441
	600	154972	110734	77751	94169	67288	47243	33627	25152	16814
	700	210938	150712	105830	128181	91593	64305	45774	34237	22893

* Remember to apply appropriate service factors.



Gearflex A series Double Engagement Flanged Spacer type DAFS

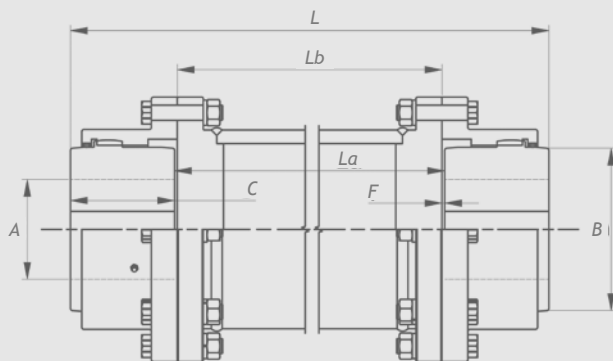

Type A

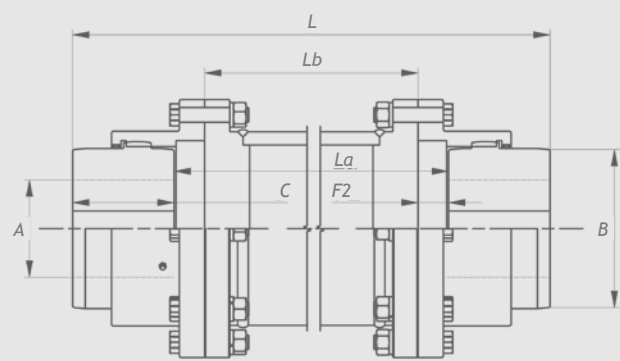

Type B (Hubs reversed)

Coupling size	Power /100rpm kW	Torque nominal Nm	Speed max** rpm	Bore A1		Dimensions							
				Max* mm	Min mm	B mm	C mm	D mm	F mm	F2 mm	La mm	Lb mm	Lb min mm
GF10DAFS	14.9	1423		46	14	60	43	116	1.5	3			75
GF15DAFS	28.2	2693		57	20	76	49	152	1.5	6.5			85
GF20DAFS	48	4584		78	27	102	62	178	1.5	12.5			95
GF25DAFS	77.6	7411		90	27	117	77	213	2.5	9.5			110
GF30DAFS	128	12224		110	39	143	91	240	2.5	21			110
GF35DAFS	196	18718	**	127	39	165	106	279	3	24	***	***	125
GF40DAFS	312	29796		145	55	191	121	318	3	28.5			125
GF45DAFS	431	41161		165	55	216	135	346	4	32.5			125
GF50DAFS	578	55199		185	55	241	153	389	4	46			145
GF55DAFS	857	81844		205	55	267	175	425	4	49			145
GF60DAFS	1096	104668		225	55	292	188	457	4	55.5			145
GF70DAFS	1640	156620		260	55	343	221	527	4.5	66.5			145

Long hub versions available. Contact Renold for details. See key stress calculations on Page 13. Renold can also supply cardan shaft assemblies.

* Maximum Bore - The maximum bores shown are absolute maximums. Under normal circumstances the boss to bore ratio should not be less than 1.5 for standard applications. Consult Renold for overbore approval.

** Speed max rpm dependant on length of spacer, please consult Renold.

*** For all orders please state length of spacer and speed required.

Type A - $Lb = La - 2 \times F$

Type B - $Lb = La - 2 \times F2$

Ordering code

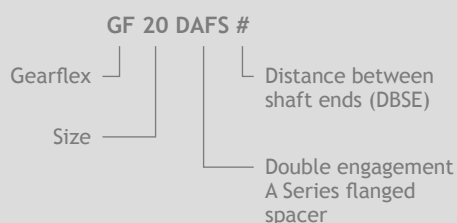

Gearflex Vertical Double Engagement type VA

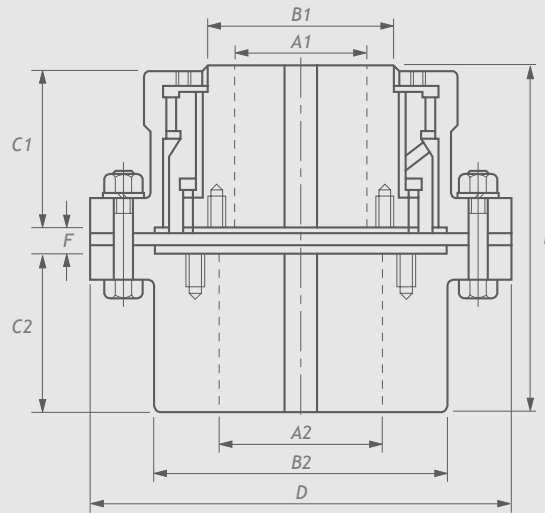

Coupling size	Power /100rpm kW	Torque nominal Nm	Speed max** rpm	Bore A1		Bore A2		Dimensions								Offset Max mm	
				Max* mm	Min mm	Max mm	Min mm	B1 mm	B2 mm	C1 mm	C2 mm	D mm	F mm	L mm	Mass kg		WR ² kg m ²
GF15VA	14.9	1423	7100	46	14	75	20	60	98	49	47	152	8	104	9	0.019	0.8
GF20VA	28.2	2693	5400	57	20	95	27	76	124	62	60	178	8	130	17.5	0.044	1.0
GF25VA	48	4584	4800	78	27	110	27	102	148	77	75	213	9	161	30	0.107	1.2
GF30VA	77.6	7411	4250	90	27	130	39	117	173	91	89	240	10	190	40	0.200	1.4
GF35VA	128	12224	4000	110	39	155	39	143	201	106	104	279	12	222	64	0.446	1.7
GF40VA	196	18718	3600	127	39	180	55	165	233	121	116	318	13	250	94	0.842	2.0
GF45VA	312	29796	3290	145	55	200	55	191	262	135	130	346	17	282	128	1.350	2.3
GF50VA	431	41161	2920	165	55	225	55	216	294	153	148	389	17	318	187	2.800	2.6
GF55VA	578	55199	2630	185	55	250	55	241	324	175	164	425	17	356	245	3.940	3.0
GF60VA	857	81844	2320	205	55	265	55	267	349	188	182	457	20	390	300	5.130	3.4
GF70VA	1096	104668	2120	225	55	310	55	292	406	221	221	527	23	465	475	11.040	3.9

* Maximum Bore - The maximum bores shown are absolute maximums. Under normal circumstances the boss to bore ratio should not be less than 1.5 for standard applications. Consult Renold for overbore approval.

** Speed in excess of these shown may require additional balancing.

Ordering code

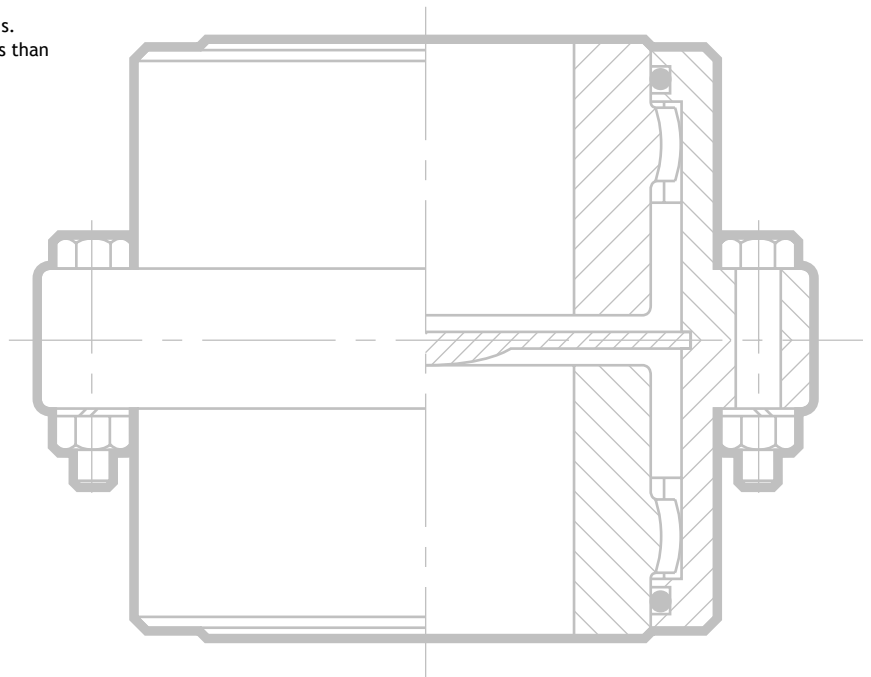
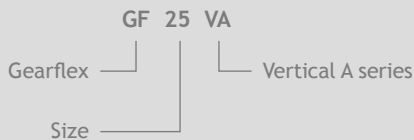

Gearflex High Speed Double Engagement type NTS

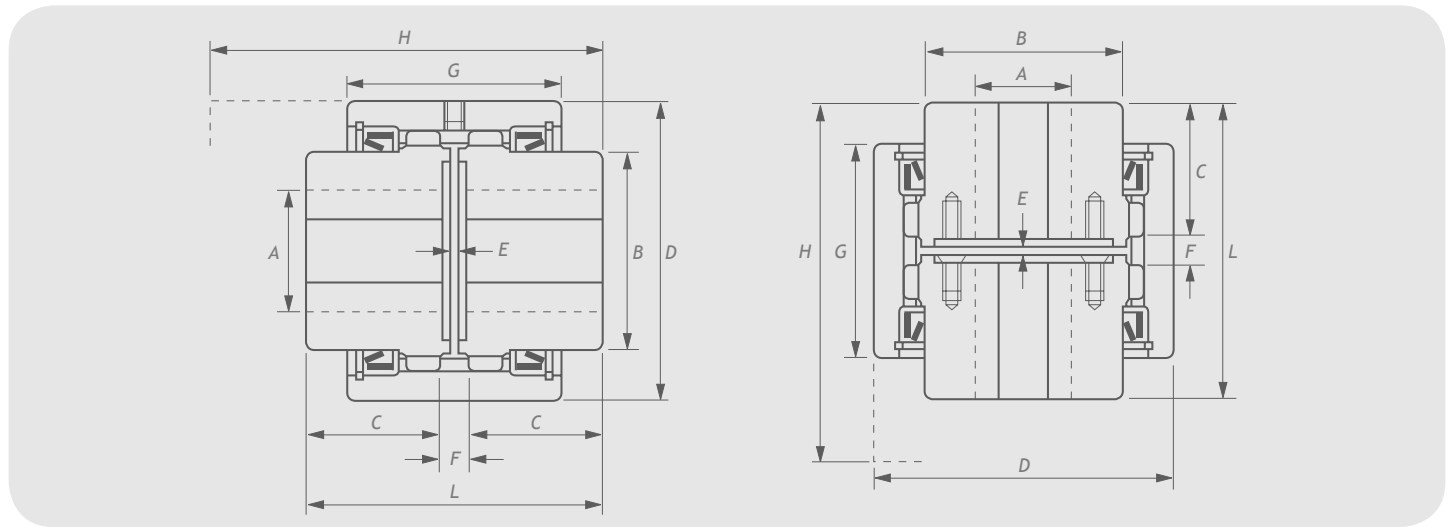

Coupling size	Power /100rpm kW	Torque nominal Nm	Speed max** rpm	Bore A		Dimensions									Offset max mm	End float mm
				Max* mm	Min mm	B mm	C mm	D mm	E mm	F mm	G mm	H mm	L mm	Mass kg		
GF10NTS #	7	668	10000	24	10	36	43	67	3	9	70	126	95	1.8	0.18	1.5
GF11NTS #	10	955	10000	30	12	46	43	79	3	9	70	126	95	2.7	0.18	1.5
GF12NTS #	16	1528	10000	40	12	58	44	92	3	9	73	130	97	3.6	0.18	1.5
GF15NTS #	20	1910	10000	40	13	65	49	98	3	9	76	139	107	4.5	0.20	1.5
GF20NTS #	37	3562	10000	55	18	82	56	121	3	11	92	162	123	7.7	0.20	1.5
GF25NTS #	64	6112	10000	70	18	107	59	146	6	18	105	186	136	13	0.23	1.5
GF30NTS #	100	9550	8500	80	30	127	67	171	6	18	114	204	152	20	0.33	3
GF35NTS #	163	15570	7250	100	38	154	70	200	6	18	121	213	158	30	0.36	3
GF40NTS #	233	22250	6400	115	60	178	86	229	6	18	140	248	190	42	0.38	3
GF45NTS #	342	32660	5700	125	72	203	89	260	6	18	146	258	196	58	0.41	3
GF50NTS #	428	40870	5200	145	85	225	99	283	6	18	152	273	216	74	0.43	3
GF60NTS #	867	82800	4500	165	85	263	114	324	6	18	184	321	246	120	0.46	3
GF65NTS #	1090	104223	4200	180	85	285	114	349	6	18	184	321	246	130	0.48	3
GF70NTS #	1255	120000	3900	190	85	304	124	375	6	18	191	337	266	175	0.48	3

Misalignment angle (degrees)	Rating factor
1.50	1.00
1.00	1.15
0.75	1.30
0.50	1.55
0.00	2.00

Catalogue ratings shown are nominal values at 1.50 degrees.
 For values at misalignments less than 1.50 degrees:-
 Multiply nominal catalogue values by factor in table left.

* Maximum Bore - The maximum bores shown are absolute maximums.
 Under normal circumstances the boss to bore ratio should not be less than 1.5 for standard applications. Consult Renold for overbore approval.

** Speed in excess of these shown may require additional balancing.

Ordering code

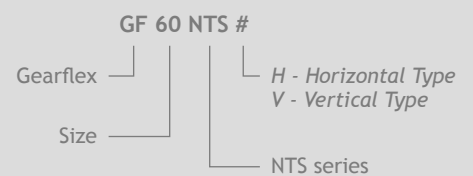

Gearflex Interchange Information



Interchangeability to AGMA Standard

Manufacturer	Coupling range	AGMA standard	Coupling Sizes												
			10	15	20	25	30	35	40	45	50	55	60	70	
Renold	Gearflex DA	Yes	10	15	20	25	30	35	40	45	50	55	60	70	
Falk/Rexnord	Lifelign G20	Yes	1010G	1015G	1020G	1025G	1030G	1035G	1040G	1045G	1050G	1055G	1060G	1070G	
Flender	Zapex ZIN	Yes	1	1.5	2	2.5	3	3.5	4	4.5	5	5.5	6	7	
Bibby	FD AGMA	Yes	10	15	20	25	30	35	40	45	50	55	60	70	
David Brown	Series X G20	Yes	1010G	1015G	1020G	1025G	1030G	1035G	1040G	1045G	1050G	1055G	1060G	1070G	
Maina	AGMA N	Yes	1	1.5	2	2.5	3	3.5	4	4.5	5	5.5	6	7	
Maina	GO-A	No	0	1	2	3	4	5	6	7	8	9	10	11	
Kopflex	Series H	Yes	1	1 1/2	2	2 1/2	3	3 1/2	4	4 1/2	5	5 1/2	6	7	
Jaure	MT	No	52	62	78	98	112	132	156	174	190	210	233	275	
Lovejoy/Sier Bath		Yes	1	1 1/2	2	2 1/2	3	3 1/2	4	4 1/2	5	5 1/2	6	7	
Esco	FST	No	45	60	75	95	110	130	155	175	195	215	240	275	
CMD	Senior	No	50	68	80	100	115	135	150	170	190	215	230	250	
Renk	LBk	No	32 or 38	48	60	70 or 80	90	110	125	140	160	180 or 190	200	225	

Coupling size	No of bolts	Bolt size inch	PCD mm	Outer dia (A) mm	Flange thickness (B) mm	Inner dia (C) mm
GF10	6	0.250"	95.25	116	14.3	70
GF15	8	0.375"	122.24	152	19	87
GF20	6	0.500"	149.23	178	19	113
GF25	6	0.625"	180.98	213	22.2	133
GF30	8	0.625"	206.38	240	22.2	159
GF35	8	0.750"	241.3	279	28.6	186
GF40	8	0.750"	279.4	318	28.6	211
GF45	10	0.750"	304.8	346	28.6	240
GF50	8	0.875"	368.3	425	38.1	265
GF55	14	0.875"	400.05	457	25.4	327
GF60	14	0.875"	463.55	527	28.6	378

AGMA flange details - common dimensions

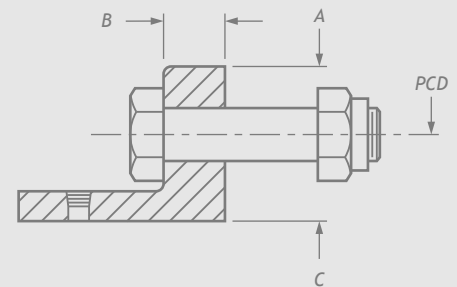

The best range of solution chain products available anywhere



RENOLD **Synergy**™

- High performance
- Superior wear life
- Outstanding fatigue resistance



RENOLD **Syno**™

- Maintenance free
- Self-lubricating chain
- Food industry-approved lubricant



RENOLD

- Best premium chain
- Leading performance
- Solid bush / solid roller / end softened pin



Hydro-Service™

- Superior corrosion resistant coating
- Alternative choice to stainless steel chain
- Will not chip or peel
- Hexavalent chrome-free



Steel Pin Bush Roller Chain

- Manufactured to international stds
- Full range of pitch alternatives
- Breaking loads 13 to 900 kN as std
- Attachments to suit varied applications

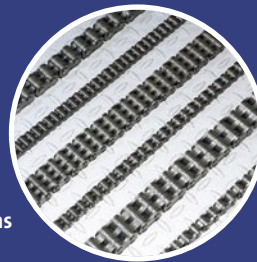

Leaf Chain

- Comprehensive ranges used worldwide for safety critical lifting applications
- 100 years experience in developing and maintaining lifting chain



Steel Knuckle Chain

- Heavy duty, detachable elevator chains
- Integral K type attachments
- Breaking loads from 642kN to 1724kN
- Sealed joint to extend chain life

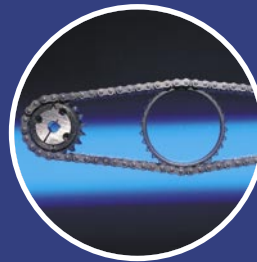

Roll-Ring™

- Revolutionary chain tensioner
- Installed in seconds and self adjusting
- Maintenance free
- Also acts as noise damper



Customised Engineering Chain

- Wide range to suit specialised applications using high specification materials and treatment processes
- Designed in close collaboration with customer



Smartlink™

- Load monitoring technology
- Technical reports & data logging

RENOLD
Superior Chain Technology

AUSTRALIA

Melbourne (Victoria)
Tel + 61 (03) 9262 3333
Fax + 61 (03) 9561 8561
also at: Sydney, Brisbane, Adelaide, Perth,
Newcastle, Wollongong, Townsville

AUSTRIA

Vienna
Tel + 43 (0) 13303484 0
Fax + 43 (0) 13303484 5

BELGIUM

Brussels
Tel + 32 (0) 2 201 1262
Fax + 32 (0) 2 203 2210

CANADA

Brantford (Ontario)
Tel + 1 519 756 6118
Fax + 1 519 756 1767
also at: Montreal

CHINA

Shanghai
Tel + 86 21 5046 2696
Fax + 86 21 5046 2695

CZECH REPUBLIC

Jaroslavice
Tel + 42 67 7211074
Fax + 42 67 7211074

DENMARK

Brøndby (Copenhagen)
Tel + 45 43 452611
Fax + 45 43 456592

FRANCE

Seclin
Tel + 33 (0) 320 16 29 29
Fax + 33 (0) 320 16 29 00
Calais (chain only)
Tel + 33 (0) 321 97 99 45
Fax + 33 (0) 321 97 83 45

GERMANY

Mechernich
Tel + 49 (0) 2256 95 90 74
Fax + 49 (0) 2256 95 91 69
renold.deutschland@renold.com

HUNGARY

Budapest
Tel + 36 30 228 3269
Fax + 36 1 287 808
peter.toka@renold.com

INDIA

Colmbatore
Tel +91 422 2532 357
Tel +91 422 2532 358
marketing@renold.in

MALAYSIA

Petaling Jaya
Tel + 603 5191 9880
Fax + 603 5191 9881
also at: Johor Bharu, Ipoh, Butterworth

NETHERLANDS

Amsterdam
Tel + 31 206 146661
Fax + 31 206 146391

NEW ZEALAND

Auckland
Tel + (0) 64 9 828 5018
Fax + (0) 64 9 828 5019
also at: Christchurch

SINGAPORE

Singapore
Tel + 65 6760 2422
Fax + 65 6760 1507

SOUTH AFRICA

Benoni
Tel + (0) 27 11 747 9500
Fax + (0) 27 11 747 9505
also at: Durban, Cape Town,
Port Elizabeth, Witbank

SPAIN

Renold Hi-Tec Couplings SA
Tel + 34 93 6380558
Fax + 34 93 6380737
renold@renold-hitec.com

SWEDEN

Brøndby (Copenhagen)
Tel + 45 43 245028
Fax + 45 43 456592

SWITZERLAND

Dübendorf (Zürich)
Tel + 41 (0) 1 824 8484
Fax + 41 (0) 1 824 8411
also at: Crissier (Lausanne)

UK

Renold Clutches & Couplings, Wales
Tel + 44 (0) 29 20792737
Fax + 44 (0) 29 20791360
couplings@cc.renold.com

Renold Hi-Tec Couplings, Halifax

Tel + 44 (0) 1422 255000
Fax + 44 (0) 1422 320273
couplings@hitec.renold.com

Renold Gears, Milnrow

Tel + 44 (0) 1706 751000
Fax + 44 (0) 1706 751001
sales@gears.renold.com

USA

Renold Ajax
Westfield, New York
Tel + 1 716 326 3121
Fax + 1 716 326 6121

WEB

www.renold.com

E-MAIL

enquiry@renold.com

For other country distributors please
contact Renold UK or visit the renold
website.

Whilst all reasonable care in compiling
the information contained in this brochure
is taken, no responsibility is accepted for
printing errors. All information contained
in this brochure is subject to change after
the date of publication.

RENOLD
Superior Coupling Technology

www.renold.com