

RINGFEDER Products are available from **MARYLAND METRICS**
Locking Assemblies &
Locking Elements

US
12|2010



Partner for performance

RINGFEDER Products are available from **MARYLAND METRICS**

P.O. Box 261 Owings Mills, MD 21117 USA phones: (410)358-3130 (800)638-1830 faxes: (410)358-3142 (800)872-9329
email: sales@mdmetric.com web: <http://mdmetric.com> RFQ form: <http://mdmetric.com/rfq.htm>



A Global Presence For You

The RINGFEDER POWER TRANSMISSION GMBH was founded in 1922 in Krefeld, Germany to fabricate and promote Friction Spring technology. Today we have expanded our offerings to top power transmission and damping products. Innovative thinking sets us apart and allows us to develop progressive and economical solutions to support our customers.





Special applications require special solutions

Our extensive range of RINGFEDER POWER TRANSMISSION products can be applied to solve most applications. We don't just sell, but by understanding the individual requirements of our customers (e.g. loads on the components, easy installation/removal capability and reduction of production costs) assist you in every step with innovative engineering to plan efficient and technically mature solutions.



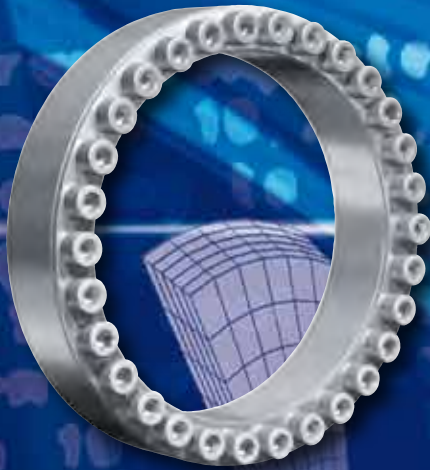

Locking Assemblies

Overview	Page 6
Characteristics.....	Page 8
RINGFEDER® RfN 7012-IN/7012.....	Page 10
RINGFEDER® RfN 7013.0-IN/7013.0.....	Page 14
RINGFEDER® RfN 7013.1-IN/7013.1.....	Page 18
RINGFEDER® RfN 7014.....	Page 22
RINGFEDER® RfN 7015.0.....	Page 24
RINGFEDER® RfN 7015.1.....	Page 26
RINGFEDER® RfN 7515.....	Page 28

Content

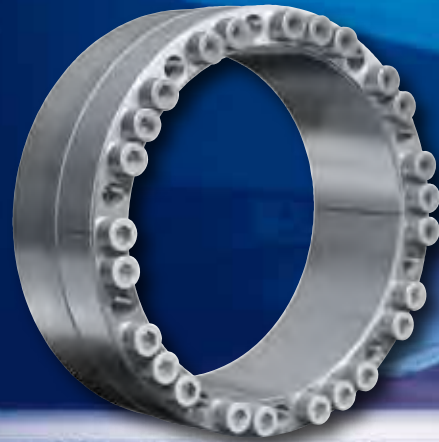

Locking Assemblies for Bending Moments

Overview	Page 30
Characteristics.....	Page 32
RINGFEDER® RfN 7012.....	Page 34
RINGFEDER® RfN 7012.2.....	Page 36
RINGFEDER® RfN 7015.0.....	Page 38
RINGFEDER® RfN 7015.1.....	Page 40
RINGFEDER® RfN 7515.....	Page 42

All technical details and information is non-binding and cannot be used as a basis for legal claims. The user is obligated to determine whether the represented products meet his requirements. We reserve the right at all times to carry out modifications in the interests of technical progress. Upon the issue of this catalog all previous brochures and questionnaires on the products displayed are no longer valid.

Content



Locking Elements

Overview	Page 44
Characteristics.....	Page 46
RINGFEDER® RfN 8006/GSA	Page 48

Content

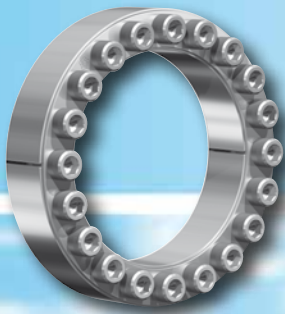

Locking Assemblies

STAINLESS

Overview	Page 54
Characteristics.....	Page 56
RINGFEDER® RfN 7012-IN/7012.....	Page 58
RINGFEDER® RfN 7061.....	Page 62
RINGFEDER® RfN 7110.....	Page 64

Locking Elements

RINGFEDER® RfN 8006.....	Page 66
--------------------------	---------



Special Solutions

Overview	Page 68
Special Locking Assemblies.....	Page 70
Flange Couplings	Page 71

Installation and removal instructions

Locking Assemblies.....	Page 72
Locking Elements.....	Page 86

RINGFEDER® Locking Assemblies

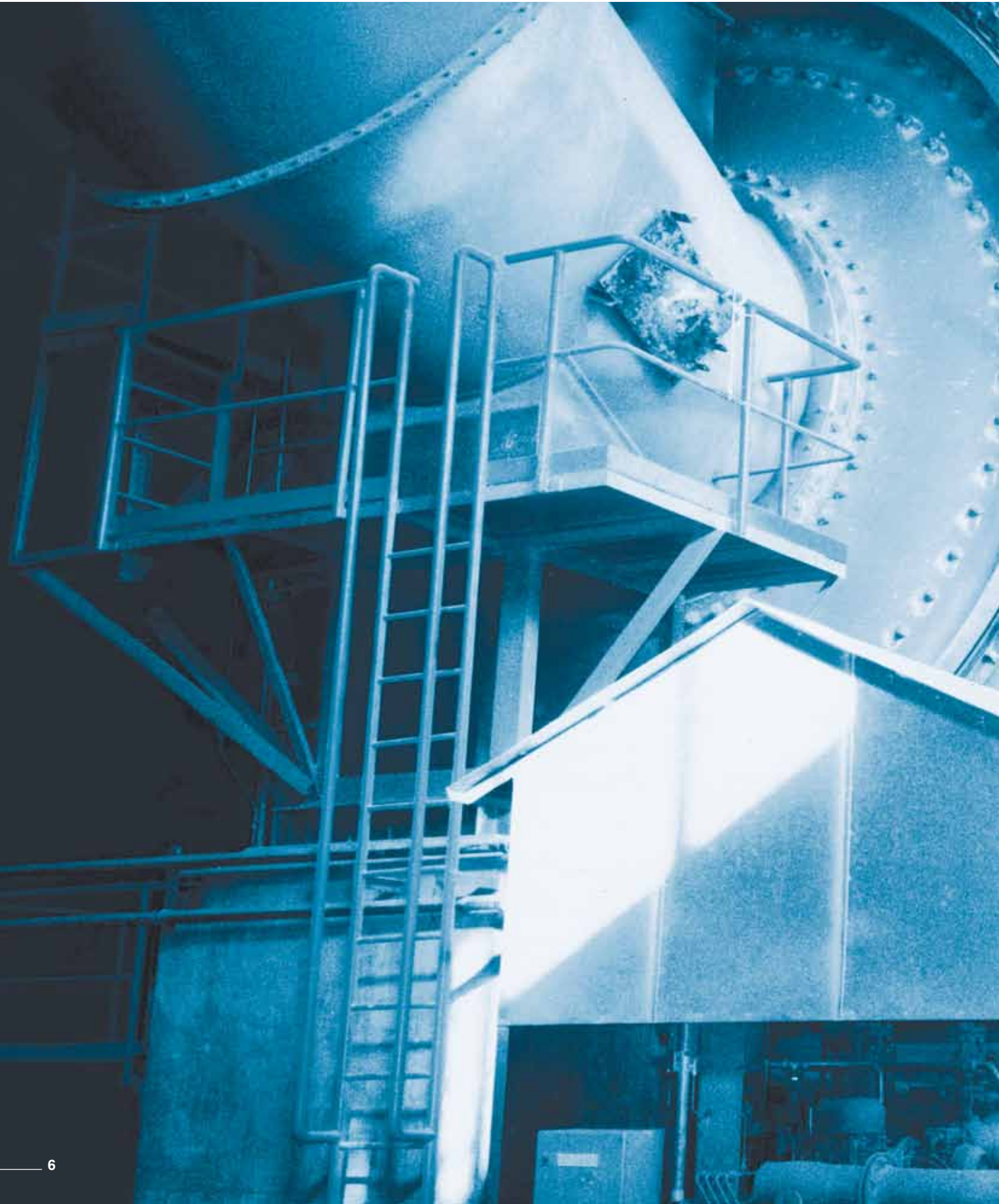

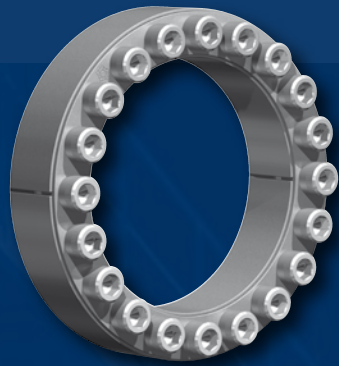

RfN 7012

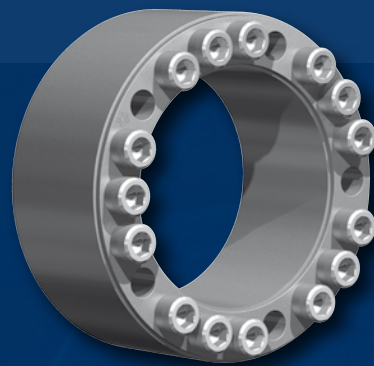

RfN 7014

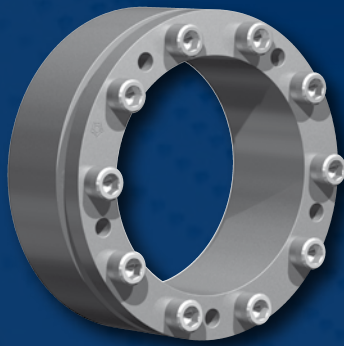

RfN 7013.0

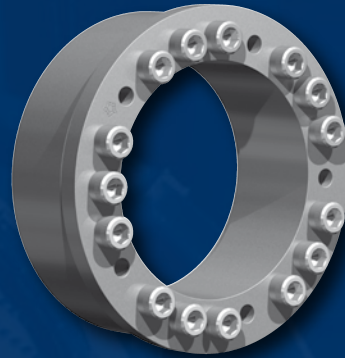

RfN 7013.1

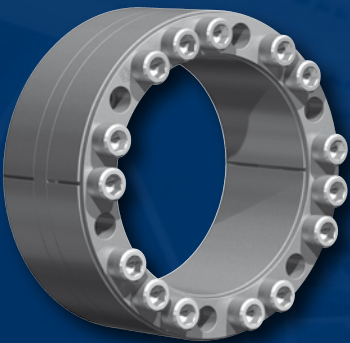

RfN 7015.0

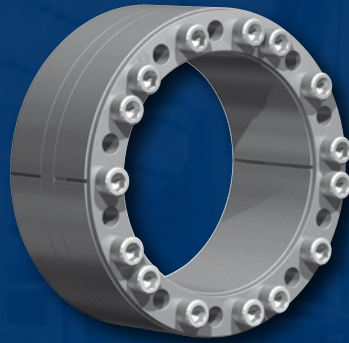

RfN 7015.1

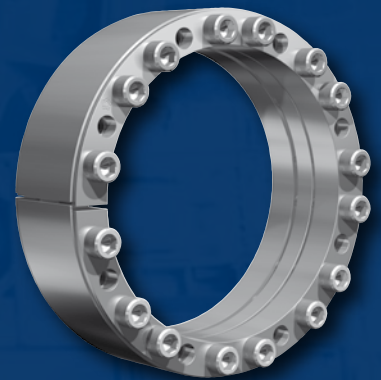

RfN 7515

Characteristics

Inexpensive manufacturing – The large tolerances that are possible and the simple turning process guarantee inexpensive manufacturing.

Simple installation – Only a few screws need to be tightened, alignment to precise angles between the hub and shaft is possible in any position, no special installation work is required.

Simple dismantling – RINGFEDER® Locking Assemblies are manufactured with threaded extraction holes, so that no additional auxiliary equipment is necessary, series RfN 7012 is self-releasing.

High reversing load fatigue strength - shaft and hub are not keyed, so that there is no weakening of these components. Shaft and hub can be designed to be considerably smaller (lighter, cost and space-saving design possible).

No danger of deflection – RINGFEDER® Locking Assemblies are absolutely backlash free.

Effect similar to overload protection – After the frictional connection force has been exceeded the Locking Assemblies simply slip. Valuable machine parts are protected. The Locking Assemblies are subject to the same laws as any other connection with force transmission by friction - not suitable as overload protection.

Completely maintenance-free – no follow-up costs.

Explanations to tables

d, D, L, l, L_1 = Basic dimensions, Locking Assemblies not tightened

T = transmissible torque

F_{ax} = transmissible axial force

p_W = surface pressure between Locking Assembly and shaft

p_N = surface pressure between Locking Assembly and hub

n = fastener quantity

d_G = clamping thread

d_D = metric pullout thread dia.

T_A = maximum tightening torque for the screws considered in order to determine the values T, F_{ax}, p_W and p_N

D_N = minimum required outside hub diameter

$R_{p0,2}$ = minimum required yield point of hub material

T_{max} = maximum theoretical transmissible torque

B = minimum hub width (calculation formula at www.ringfeder.com)

C_1 = Shaft Tolerances

C_2 = Bore Tolerances

s = metric hex key size (across flats)

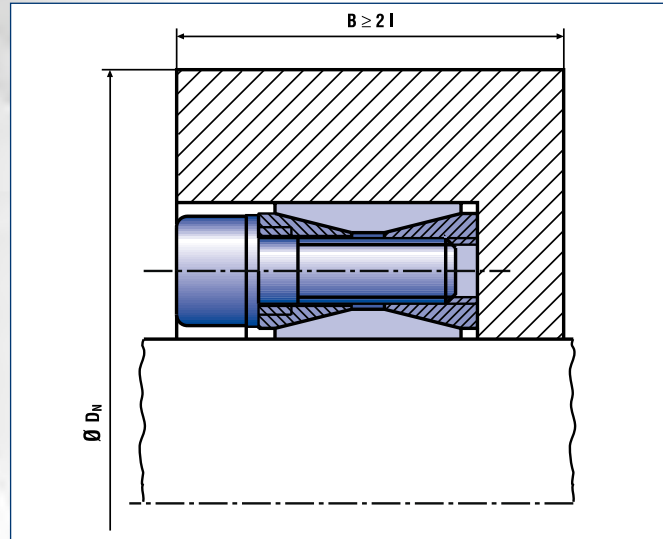

Locking Assembly RfN 7012/RfN 7012-IN · Typical installation

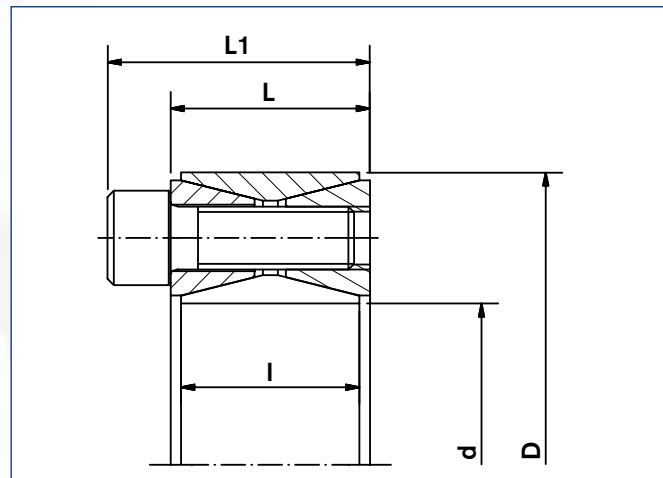

Locking Assembly RfN 7012/RfN 7012-IN · Dimensions

Characteristics

As the industry standard, the RfN 7012/RfN 7012-IN Locking Assembly is suitable for most applications.

Transmission of high loads – up to 4 RfN 7012/RfN 7012-IN Locking Assemblies can be used in series, the transmissible torques and axial forces are added. (Please contact our specialists for assistance).

Bending moment and radial loads – Combined loads can be transmitted. (Please contact our specialists for assistance).

Simplified manufacture – RfN 7012/RfN 7012-IN Locking Assemblies can bridge large clearances without the loss of transmission values.

Low risk to contamination – During the tightening process the functional surfaces of the device are under pressure, sufficient enough to keep contaminants out, thereby preserving the integrity of the device.

Adjustable transmission values – The screw tightening torque can be varied, thus allowing for different torque transmission values. RfN 7012/RfN 7012-IN Locking Assemblies can be tightened and released repeatedly.

Example applications:

sprockets, gears, coupling hubs, conveyor pulleys, idler wheels, sheaves



Locking Assembly RfN 7012/RfN 7012-IN · Belt pulley

Size	Locking Assembly dimensions							Transmissible torques or axial forces		Surface Pressure		Locking screws DIN EN ISO 4762-12.9			Weight		min. D _N *				
	d	C ₁	D	C ₂	L	I	L ₁	T	F _{ax}	Shaft PW	Hub PN	Thread		WT	d _D	Rp0.2[psi]					
	Inch	Inch						lb-ft	lbs	psi		n	d _G	s	T _A	lb-ft	lbs	mm	36000 45000 62000		
													mm					Inch			
3/4	0.750	+0	1.850	-0	0.787	0.669	1.083	225	7200	35000	14200	8	M6x18	5	13	0.5	M8	2.565	2.395	2.227	
1	1.000	-0.002	1.969	+0.002	0.787	0.669	1.083	337	8088	33000	16800	9	M6x18	5	13	0.6	M8	2.915	2.679	2.454	
1 1/8	1.125		2.165		0.787	0.669	1.083	424	9045	30000	15600	10	M6x18	5	13	0.7	M8	3.108	2.878	2.655	
1 3/16	1.1875		2.159		0.813	0.669	1.108	445	8994	31000	17100	10	M6x18	5	13	0.7	M8	3.221	2.955	2.702	
1 1/4	1.250		2.362		0.787	0.669	1.083	459	8813	35000	18600	12	M6x18	5	13	0.7	M8	3.666	3.330	3.017	
1 3/8	1.375		2.365		0.776	0.669	1.071	622	10857	32000	18700	12	M6x18	5	13	0.7	M8	3.681	3.341	3.025	
1 7/16	1.4375		2.559		0.787	0.669	1.083	748	12488	35000	19700	15	M6x18	5	13	0.8	M8	4.092	3.689	3.318	
1 1/2	1.500	+0	2.559	-0	0.787	0.669	1.083	782	12512	33500	19700	15	M6x18	5	13	0.8	M8	4.092	3.689	3.318	
1 5/8	1.625	-0.0025	2.953	+0.0025	0.945	0.787	1.319	1273	18801	39000	21500	12	M8x22	6	30	1.3	M10	4.968	4.417	3.926	
1 11/16	1.6875		2.953		0.945	0.787	1.319	1320	18773	34000	19500	12	M8x22	6	30	1.3	M10	4.696	4.240	3.819	
1 3/4	1.750		2.953		0.945	0.787	1.319	1368	18761	36000	21400	12	M8x22	6	30	1.3	M10	4.953	4.408	3.921	
1 7/8	1.875		3.150		0.945	0.787	1.319	1454	18611	34000	20300	12	M8x22	6	30	1.4	M10	5.122	4.597	4.119	
1 15/16	1.9375		3.150		0.945	0.787	1.319	1498	18556	32000	19700	12	M8x22	6	30	1.4	M10	5.037	4.541	4.085	
2	2.000		3.346		0.945	0.787	1.319	1808	21696	37000	22200	14	M8x22	6	30	1.4	M10	5.744	5.079	4.493	
2 1/8	2.125		3.346		0.945	0.787	1.319	1919	21673	35000	22300	14	M8x22	6	30	1.4	M10	5.761	5.090	4.499	
2 3/16	2.1875		3.543		0.945	0.787	1.319	1971	21625	34000	21000	14	M8x22	6	30	1.5	M10	5.875	5.245	4.678	
2 1/4	2.250		3.543		0.945	0.787	1.319	2023	21579	32000	20400	14	M8x22	6	30	1.5	M10	5.777	5.181	4.639	
2 3/8	2.375		3.531		0.996	0.787	1.370	2127	21494	30500	20600	14	M8x22	6	30	1.5	M10	5.790	5.184	4.636	
2 7/16	2.4375		3.740		0.945	0.787	1.319	2497	24586	34000	22200	16	M8x22	6	30	1.6	M10	6.421	5.677	5.022	
2 1/2	2.500		3.740		0.945	0.787	1.319	2556	24538	33000	22100	16	M8x22	6	30	1.6	M10	6.402	5.665	5.015	
2 9/16	2.5625	+0	3.737	-0	0.959	0.787	1.333	2617	24510	32000	22000	16	M8x22	6	30	1.6	M10	6.378	5.649	5.004	
2 5/8	2.625	-0.003	4.331	+0.003	1.102	0.945	1.555	3775	34514	37000	22500	14	M10x25	8	61	2.8	M12	7.502	6.616	5.840	
2 11/16	2.6875		4.331		1.102	0.945	1.555	3866	34524	36000	22400	14	M10x25	8	61	2.8	M12	7.479	6.602	5.832	
2 3/4	2.750		4.337		1.079	0.945	1.532	4017	35057	36000	22900	14	M10x25	8	61	2.8	M12	7.602	6.681	5.881	
2 7/8	2.875		4.528		1.102	0.945	1.555	4175	34852	34500	22000	14	M10x25	8	61	2.9	M12	7.728	6.844	6.063	
2 15/16	2.9375		4.528		1.102	0.945	1.555	4262	34821	34000	22100	14	M10x25	8	61	2.9	M12	7.751	6.859	6.071	
3	3.000		4.724		1.102	0.945	1.555	4332	34656	33000	21000	14	M10x25	8	61	3.1	M12	7.834	6.993	6.237	
3 1/8	3.125		4.724		1.102	0.945	1.555	4515	34675	31000	20600	14	M10x25	8	61	3.1	M12	7.746	6.936	6.203	
3 1/4	3.250		4.921		1.102	0.945	1.555	5355	39545	33000	21800	16	M10x25	8	61	3.3	M12	8.350	7.407	6.571	
3 3/8	3.375		4.921		1.102	0.945	1.555	5558	39524	34000	23400	16	M10x25	8	61	3.3	M12	8.757	7.663	6.720	
3 7/16	3.4375		5.118		1.102	0.945	1.555	5601	39105	32000	21500	16	M10x25	8	61	3.4	M12	8.609	7.655	6.805	
3 1/2	3.500		5.118		1.102	0.945	1.555	5706	39127	31000	21200	16	M10x25	8	61	3.4	M12	8.536	7.608	6.776	
3 3/4	3.750	+0	5.305	-0.0035	1.142	0.945	1.594	6914	44250	34000	24100	18	M10x25	8	61	3.6	M12	9.646	8.387	7.317	
3 15/16	3.3975		5.708		1.301	1.024	1.852	8402	51212	33000	22800	14	M12x30	10	107	4.4	M14	9.975	8.775	7.729	
4	4.000		5.843		1.299	1.024	1.850	8489	50934	32000	22000	14	M12x30	10	107	4.4	M14	9.973	8.832	7.823	
4 7/16	4.4375		6.496		1.299	1.024	1.850	10498	56778	34000	23300	16	M12x30	10	107	5.2	M14	11.525	10.093	8.859	
4 1/2	4.500		6.496		1.299	1.024	1.850	10652	56811	33000	22900	16	M12x30	10	107	5.2	M14	11.386	10.007	8.809	
4 15/16	4.9375		7.087		1.496	1.339	2.047	14493	70447	29000	20300	20	M12x35	10	107	7.7	M14	11.523	10.342	9.267	
5	5.000		7.087		1.496	1.339	2.047	14672	70426	29000	20500	20	M12x35	10	107	7.7	M14	11.588	10.384	9.293	
5 1/2	5.500	+0	7.492	-0	1.449	1.339	2.000	17804	77690	29000	21300	22	M12x35	10	107	8.5	M14	12.531	11.160	9.934	
6	6.000	-0.004	8.268	+0.004	1.496	1.339	2.047	22762	91048	30500	22200	26	M12x35	10	107	9.5	M14	14.194	12.550	11.102	
6 1/2	6.500		8.858		1.732	1.496	2.362	28336	104625	29000	21300	22	M14x40	12	170	13	M14	14.816	13.195	11.745	
7	7.000		9.252		1.732	1.496	2.362	33220	113897	29000	22000	24	M14x40	12	170	13	M14	15.791	13.985	12.388	
7 1/2	7.500	+0	9.823	-0	2.126	1.811	2.756	41369	132381	26500	20300	28	M14x45	12	170	18	M14	15.972	14.334	12.844	
7 7/8	7.875	-0.0045	10.235	+0.0045	2.051	1.811	2.681	46707	142345	26500	20400	30	M14x45	12	170	19	M14	16.688	14.966	13.402	

Ordering example: RfN 7012-IN

Series	Size
RfN 7012-IN	4

* B ≥ 2 l necessary

To continue see next page

Locking Assembly dimensions							Transmissible torques or axial forces		Surface Pressure		Locking screws DIN EN ISO 4762-12.9			Weight	min. D _N *				
d x D	d	C ₁	D	C ₂	L	I	L ₁	T	F _{ax}	Shaft P _W	Hub P _N	n	Thread d _G	T _A	WT	Rp0,2[psi]			T _{max}
Inch							lb-ft	lbs	psi			mm	lb-ft	lbs	Inch			lb-ft	
mm																			
19 x 47	0.748		1.850		0.787	0.669	1.083	229	6745	39162	15955	8	M6 x 18	13	0.5	2.680	2.476	2.280	258
20 x 47	0.787		1.850		0.787	0.669	1.083	236	6745	37712	15955	8	M6 x 18	13	0.5	2.680	2.476	2.280	273
22 x 47	0.866	0	1.850	0	0.787	0.669	1.083	266	6745	34811	15955	8	M6 x 18	13	0.5	2.680	2.476	2.280	302
24 x 50	0.945	-0.002	1.969	+0.002	0.787	0.669	1.083	317	6745	34811	17405	9	M6 x 18	13	0.6	2.961	2.711	2.474	369
25 x 50	0.984		1.969		0.787	0.669	1.083	339	6745	33360	17405	9	M6 x 18	13	0.6	2.961	2.711	2.474	384
28 x 55	1.102		2.165		0.787	0.669	1.083	420	8993	33360	17405	9	M6 x 18	13	0.7	3.256	2.981	2.721	435
30 x 55	1.181		2.165		0.787	0.669	1.083	443	8993	30459	17405	9	M6 x 18	13	0.6	3.256	2.981	2.721	465
32 x 60	1.260		2.362		0.787	0.669	1.083	561	11241	33360	18856	12	M6 x 18	13	0.7	3.691	3.347	3.028	664
35 x 60	1.378		2.362		0.787	0.669	1.083	627	11241	31910	18856	12	M6 x 18	13	0.7	3.691	3.347	3.028	723
38 x 65	1.496		2.559		0.787	0.669	1.083	775	13489	33360	18856	15	M6 x 18	13	0.8	3.999	3.627	3.280	959
40 x 65	1.575	-0.0025	2.559	+0.0025	0.787	0.669	1.083	819	13489	31910	18856	15	M6 x 18	13	0.7	3.999	3.627	3.280	1033
42 x 75	1.654		2.953		0.945	0.787	1.319	1291	17986	39162	21757	12	M8 x 22	30	1.3	5.005	4.441	3.940	1549
45 x 75	1.772		2.953		0.945	0.787	1.319	1387	17986	36261	21757	12	M8 x 22	30	1.3	5.005	4.441	3.940	1697
48 x 80	1.890		3.150		0.945	0.787	1.319	1468	17986	33360	20306	12	M8 x 22	30	1.4	5.123	4.597	4.119	1770
50 x 80	1.969		3.150		0.945	0.787	1.319	1527	17986	31910	20306	12	M8 x 22	30	1.3	5.123	4.597	4.119	1844
55 x 85	2.165		3.346		0.945	0.787	1.319	1955	22482	33360	21757	14	M8 x 22	30	1.4	5.671	5.032	4.465	2434
60 x 90	2.362		3.543		0.945	0.787	1.319	2132	22482	30459	20306	14	M8 x 22	30	1.5	5.762	5.171	4.633	2655
65 x 95	2.559	0	3.740	0	0.945	0.787	1.319	2626	24730	31910	21757	16	M8 x 22	30	1.6	6.338	5.624	4.991	3246
70 x 110	2.756	-0.003	4.331	+0.003	1.102	0.945	1.555	4020	35971	36261	21757	14	M10 x 25	61	2.8	7.340	6.513	5.779	4942
75 x 115	2.953		4.528		1.102	0.945	1.555	4286	35971	33360	21757	14	M10 x 25	61	2.9	7.674	6.809	6.042	5311
80 x 120	3.150		4.724		1.102	0.945	1.555	4544	35971	30459	20306	14	M10 x 25	61	3.1	7.682	6.894	6.178	5680
85 x 125	3.346		4.921		1.102	0.945	1.555	5495	40468	33360	21757	16	M10 x 25	61	3.3	8.340	7.400	6.567	6860
90 x 130	3.543		5.118		1.102	0.945	1.555	5768	40468	30459	21757	16	M10 x 25	61	3.4	8.674	7.697	6.829	7303
95 x 135	3.740	0	5.315	0	1.102	0.945	1.555	6904	44964	33360	23207	18	M10 x 25	61	3.6	9.403	8.242	7.239	8630
100 x 145	3.937	-0.0035	5.709	+0.0035	1.299	1.024	1.850	8188	49460	33360	23207	14	M12 x 30	107	4.4	10.100	8.853	7.775	10474
110 x 155	4.331		6.102		1.299	1.024	1.850	8984	49460	30459	21757	14	M12 x 30	107	4.7	10.341	9.176	8.142	11655
120 x 165	4.724		6.496		1.299	1.024	1.850	11212	58453	31910	23207	16	M12 x 30	107	5.2	11.492	10.073	8.847	14531
130 x 180	5.118		7.087		1.496	1.339	2.047	15048	71942	27559	18856	20	M12 x 35	107	7.7	11.076	10.044	9.084	19621
140 x 190	5.512		7.480		1.496	1.339	2.047	17851	78687	27559	21757	22	M12 x 35	107	8.5	12.677	11.249	9.981	23235
150 x 200	5.906	0	7.874	0	1.496	1.339	2.047	20654	85432	29009	21757	24	M12 x 35	107	9.0	13.344	11.841	10.507	27145
160 x 210	6.299	-0.004	8.268	+0.004	1.496	1.339	2.047	23973	89928	29009	21757	26	M12 x 35	107	9.5	14.012	12.434	11.033	31423
170 x 225	6.693		8.858		1.732	1.496	2.362	29284	105665	27559	21757	22	M14 x 40	170	13	15.012	13.321	11.820	38947
180 x 235	7.087		9.252		1.732	1.496	2.362	33710	112410	29009	21757	24	M14 x 40	170	13	15.680	13.914	12.346	44996
190 x 250	7.480		9.843		2.047	1.811	2.677	41529	134892	26108	20306	28	M14 x 45	170	18	16.007	14.365	12.872	55396
200 x 260	7.874	0	10.236	0	2.047	1.811	2.677	46840	143885	26108	20306	30	M14 x 45	170	19	16.646	14.938	13.386	62478
220 x 285	8.661	-0.0045	11.220	+0.0045	2.205	1.969	2.913	60339	168615	26108	20306	26	M16 x 50	262	25	18.246	16.375	14.672	80550
240 x 305	9.449		12.008		2.205	1.969	2.913	75903	193345	27559	21757	30	M16 x 50	262	27	20.350	18.058	16.023	101351
260 x 325	10.236	0	12.795	0	2.205	1.969	2.913	92204	215827	29009	23207	34	M16 x 50	262	29	22.636	19.841	17.426	124439
280 x 355	11.024	-0.005	13.976	+0.005	2.598	2.362	3.406	112858	247302	24658	20306	32	M18 x 60	358	42	22.728	20.397	18.276	154239
300 x 375	11.811		14.764		2.598	2.362	3.406	134987	274281	26108	20306	36	M18 x 60	358	45	24.010	21.547	19.307	185958
320 x 405	12.598		15.945		3.071	2.835	3.957	184409	350719	26108	20306	36	M20 x 70	509	65	25.930	23.270	20.851	252124
340 x 425	13.386		16.732		3.071	2.835	3.957	196580	350719	24658	20306	36	M20 x 70	509	69	27.210	24.419	21.880	267909
360 x 455	14.173	0	17.913	0	3.543	3.307	4.567	258541	436151	24658	20306	36	M22 x 80	686	93	29.131	26.142	23.425	350303
380 x 475	14.961	-0.0055	18.701	+0.0055	3.543	3.307	4.567	270712	433903	23207	18856	36	M22 x 80	686	97	29.227	26.503	23.971	369776
400 x 495	15.748		19.488		3.543	3.307	4.567	283252	431655	23207	18856	36	M22 x 80	686	101	30.457	27.619	24.980	389250
420 x 515	16.535		20.276		3.543	3.307	4.567	328985	476619	23207	18856	40	M22 x 80	686	110	31.688	28.735	25.990	454088
440 x 545	17.323		21.457		4.016	3.780	5.118	402011	555306	23207	18856	40	M24 x 90	885	142	33.534	30.409	27.504	559275
460 x 565	18.110	0	22.244	0	4.016	3.780	5.118	416764	550809	21757	17405	40	M24 x 90	885	149	33.451	30.630	27.954	584723
480 x 585	18.898	-0.006	23.031	+0.006	4.016	3.780	5.118	457334	580036	21757	17405	42	M24 x 90	885	157	34.634	31.714	28.943	640636
500 x 605	19.685		23.819		4.016	3.780	5.118	494215	602518	21757	17405	44	M24 x 90	885	160	35.819	32.799	29.933	699130
520 x 630	20.472		24.803		4.016	3.780	5.118	520033	609263	21032	17405	45	M24 x 90	885	176	37.299	34.154	31.169	743610
540 x 650	21.260	0	25.591	0	4.016	3.780	5.118	539211	608813	20306	16680	45	M24 x 90	885	181	37.767	34.742	31.845	772230
560 x 670	22.047	-0.007	26.378	+0.007	4.016	3.780	5.118	595271	647932	20306	17405	48	M24 x 90	885	187	39.668	36.322	33.149	854181

Locking Assembly dimensions								Transmissible torques or axial forces		Surface Pressure		Locking screws DIN EN ISO 4762-12.9			Weight	min. D _N *				
d x D	d	C ₁	D	C ₂	L	I	L ₁	T	F _{ax}	Shaft p _W	Hub p _N	n	Thread d _G	T _A	WT	Rp0,2[psi]			T _{max}	
mm	Inch							lb-ft	lbs	psi			mm	lb-ft	lbs	Inch			lb-ft	
																	36000	45000	62000	
580 x 690	22.835	0	27.165	0	4.016	3.780	5.118	640267	673561	21032	17405	50	M24 x 90	885	194	40.851	37.406	34.138	921601	
600 x 710	23.622	-0.007	27.953	+0.007	4.016	3.780	5.118	660921	671987	20306	16680	50	M24 x 90	885	201	41.253	37.949	34.784	953319	
620 x 730	24.409		28.740		4.016	3.780	5.118	708867	697617	20306	16680	52	M24 x 90	885	205	42.414	39.017	35.764	1024501	
640 x 750	25.197		29.528		4.016	3.780	5.118	759026	723022	20306	17405	54	M24x90	885	212	44.405	40.660	37.107	1098265	
660 x 770	25.984		30.315		4.016	3.780	5.118	809923	748201	20306	17405	56	M24x90	885	218	45.588	41.744	38.096	1174536	
680 x 790	26.772		31.102		4.016	3.780	5.118	832790	746853	19581	16680	56	M24x90	885	225	45.900	42.224	38.703	1210164	
700 x 810	27.559		31.890		4.016	3.780	5.118	916880	798786	20306	17405	60	M24x90	885	229	47.957	43.912	40.076	1334677	
720 x 830	28.346	0	32.677	0	4.016	3.780	5.118	941222	1247077	19581	17405	60	M24x90	885	236	49.140	44.996	41.065	1372812	
740 x 850	29.134	-0.008	33.465	+0.008	4.016	3.780	5.118	998020	822617	19581	17405	62	M24x90	885	243	50.325	46.081	42.055	1458009	
760 x 870	29.922		34.252		4.016	3.780	5.118	1056293	847572	19581	17405	64	M24x90	885	249	51.509	47.165	43.044	1545714	
780 x 890	30.709		35.039		4.016	3.780	5.118	1099814	859487	19581	17405	65	M24x90	885	256	52.692	48.249	44.033	1611142	
800 x 910	31.496		35.827		4.016	3.780	5.118	1143334	871403	19581	17405	66	M24x90	885	260	53.877	49.334	45.023	1677898	
820 x 930	32.283		36.614		4.016	3.780	5.118	1205295	896358	19581	17405	68	M24x90	885	267	55.061	50.417	46.012	1771947	
840 x 950	33.071		37.402		4.016	3.780	5.118	1269470	921313	19581	17405	70	M24x90	885	273	56.246	51.503	47.002	1868577	
860 x 970	33.858		38.189		4.016	3.780	5.118	1334382	946268	19581	17405	72	M24x90	885	280	57.429	52.586	47.991	1967715	
880 x 990	34.646		38.976		4.016	3.780	5.118	1401506	971223	19581	17405	74	M24x90	885	284	58.613	53.670	48.980	2069361	
900 x 1010	35.433	0	39.764	0	4.016	3.780	5.118	1450928	982914	19581	17405	75	M24x90	885	291	59.798	54.755	49.971	2145042	
920 x 1030	36.220	-0.009	40.551	+0.009	4.016	3.780	5.118	1501087	994604	19581	17405	76	M24x90	885	298	60.981	55.839	50.960	2221904	
940 x 1050	37.008		41.339		4.016	3.780	5.118	1571900	1019559	19581	17405	78	M24x90	885	304	62.166	56.924	51.950	2329967	
960 x 1070	37.795		42.126		4.016	3.780	5.118	1644188	1044290	19581	17405	80	M24x90	885	309	63.350	58.007	52.939	2440539	
980 x 1090	38.583		42.913		4.016	3.780	5.118	1697298	1055980	18856	17405	81	M24x90	885	315	64.533	59.091	53.928	2522564	
1000 x 1110	39.370		43.701		4.016	3.780	5.118	1751145	1067671	18856	17405	82	M24x90	885	322	65.718	60.176	54.918	2605843	

Bestellbeispiel / Ordering example: RfN 7012

* B ≥ 2 l necessary

To continue see next page

Baureihe/Series	d	D
RfN 7012	200	260

■ Mounting of Locking Assembly

The Locking Assemblies are supplied slightly oiled and ready-to-use. The values for T, F_{ax}, p_W and p_N apply to Locking Assemblies installed in oiled condition.

■ Surface finishes

For shafts and hub bores

R_a = 125 RMS

■ Tolerances

We recommend the following mounting tolerances

shaft: k9-h9 · hub: N9-H9 - see table above

shaft: k11-h11 · hub: N11-H11

To avoid deformation of the relatively thickwalled thrust rings, the Locking Assembly should be located as symmetrically as possible between shaft and hub bore. If the shaft is smaller than nominal d, the bore should exceed nominal D to the same extent and vice versa. The true run-out quality is determined by the direct centering between shaft and hub.

■ Location of several Locking Assemblies RfN 7012

If several Locking Assemblies are to be installed, the transmission values of the table can be added when the Locking Assemblies are located within a distance of 4 x L₁.

■ Change of screw tightening torques

The Locking Assemblies are equipped with 12.9 grade screws. A reduction of the screw tightening torque is possible. The lowest allowable screw tightening torque is approximately 50% of T_A. There is an approximate linear relationship between T, T_A, F_{ax}, p_W and p_N.

■ Auxiliary Threads

To facilitate removal, the front thrust rings have auxiliary threads for pull-out screws.

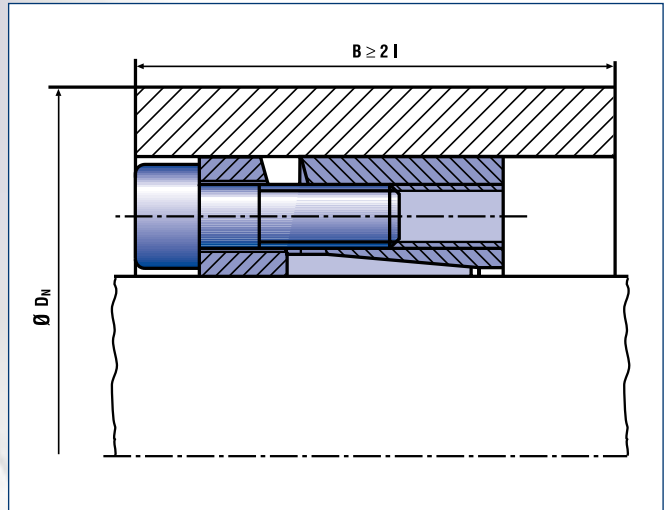
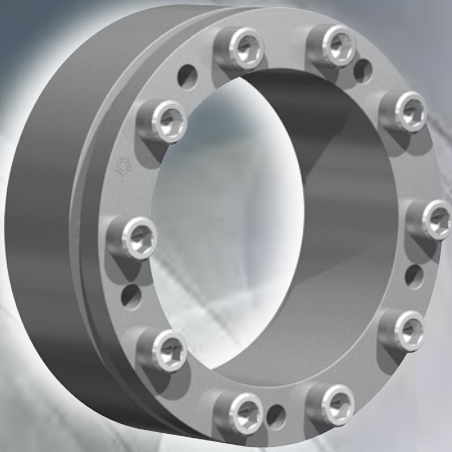

Locking Assembly RfN 7013.0-IN · Typical installation

Characteristics

Excellent centering ability – Due to the shallow tapered design the RfN 7013.0-IN Locking Assemblies are self-centering.

Easy trouble free assembly/removal – The reinforced flange prevents the Locking Assembly from distorting when the jacking screws are used during assembly and removal.

High rotation speed – The dimensional accuracy of the RfN 7013.0-IN Locking Assemblies allows their use in applications with higher rotational speeds.

High radial loads – The material strength of the RfN 7013.0-IN Locking Assemblies makes them especially suitable for applications with high radial loads.

Example applications:

Crane running wheels, couplings, gears, flywheels, fan blades

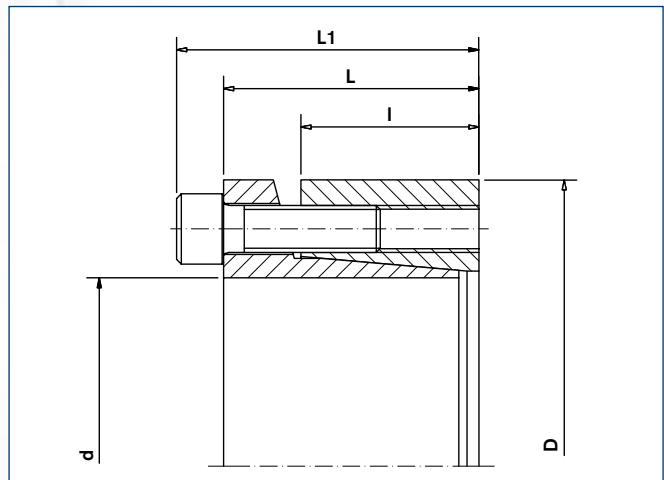

Locking Assembly RfN 7013.0-IN · Dimensions

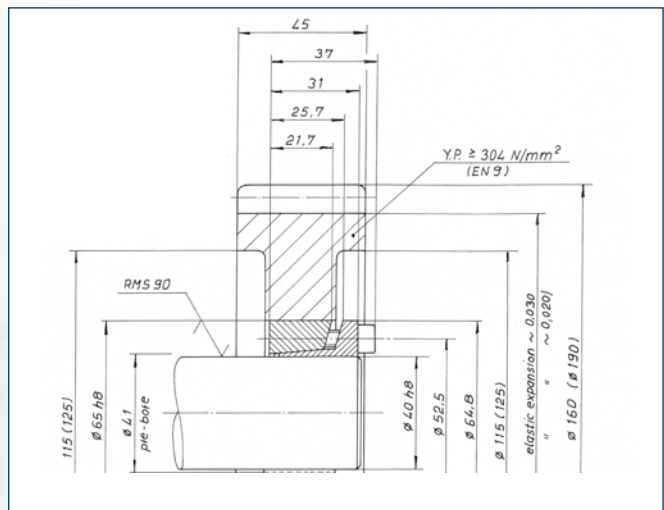

Locking Assembly RfN 7013.0-IN · Gear (metric example)

Size	Locking Assembly dimensions							Transmissible torques or axial forces		Surface Pressure		Locking screws DIN EN ISO 4762-12.9				Weight	min. D _N *		
	d	C ₁	D	C ₂	L	I	L ₁	T	F _{ax}	Shaft P _W	Hub P _N	n	d _G	s	T _A		WT	R _{p0,2} [psi]	
	Inch	Inch						lb-ft	lbs	psi			mm		lb-ft	lbs	Inch		
1	1.000	+0	1.969	-0 +0.0018	1.220	0.854	1.457	323	7752	40170	15070	5	M6x20	5	13	0.7	2.875	2.591	2.398
1 3/16	1.1875	-0.0013	2.165		1.220	0.854	1.457	385	7781	33800	13650	5	M6x20	5	13	0.8	3.000	2.773	2.587
1 1/4	1.250	+0 -0.0016	2.362		1.220	0.854	1.457	531	10195	38560	15070	6	M6x20	5	13	0.9	3.375	3.108	2.876
1 3/8	1.375		2.362		1.220	0.854	1.457	585	10211	35055	15070	6	M6x20	5	13	0.9	3.375	3.108	2.876
1 7/16	1.4375		2.559		1.220	0.854	1.457	620	10351	33495	13935	6	M6x20	5	13	1.0	3.625	3.296	3.069
1 1/2	1.500		2.559		1.220	0.854	1.457	647	10352	32100	13935	6	M6x20	5	13	1.0	3.625	3.296	3.069
1 5/8	1.625		2.953		1.496	0.996	1.811	1234	18225	43870	19055	6	M8x25	6	30	1.7	4.750	4.202	3.796
1 3/4	1.750		2.953		1.496	0.996	1.811	1329	18226	40740	19055	6	M8x25	6	30	1.7	4.750	4.202	3.796
1 7/8	1.875		3.150		1.496	0.996	1.811	1426	18253	38070	17915	6	M8x25	6	30	1.8	4.875	4.381	3.986
1 15/16	1.9375		3.150		1.496	0.996	1.811	1473	18246	36840	17915	6	M8x25	6	30	1.8	4.875	4.381	3.986
2	2.000		3.150	1.496	0.996	1.811	1521	18252	35690	17915	6	M8x25	6	30	1.8	4.875	4.381	3.986	
2 1/8	2.125		3.346	1.496	0.996	1.811	1803	20363	39125	19625	7	M8x25	6	30	1.8	5.500	4.816	4.335	
2 3/16	2.1875	3.346	1.496	0.996	1.811	1856	20363	38005	19625	7	M8x25	6	30	1.8	5.500	4.816	4.335		
2 1/4	2.250	3.543	1.496	0.996	1.811	1908	20352	36875	18485	7	M8x25	6	30	1.9	5.500	4.984	4.518		
2 3/8	2.375	3.543	1.496	0.996	1.811	2014	20352	34935	18485	7	M8x25	6	30	1.9	5.500	4.984	4.518		
2 7/16	2.4375	3.740	1.496	0.996	1.811	2466	24281	38965	20050	8	M8x25	6	30	2.1	6.125	5.430	4.873		
2 1/2	2.500	3.740	1.496	0.996	1.811	2530	24288	37990	20050	8	M8x25	6	30	2.1	6.125	5.430	4.873		
2 9/16	2.5625	3.740	1.496	0.996	1.811	2593	24286	37065	20050	8	M8x25	6	30	2.1	6.125	5.430	4.873		
2 3/4	2.750	4.331	1.969	1.315	2.362	3680	32116	34770	18200	7	M10x35	8	61	4.6	6.750	6.058	5.502		
2 7/8	2.875	4.528	1.969	1.315	2.362	3845	32097	33300	16920	7	M10x35	8	61	4.9	6.875	6.176	5.653		
2 15/16	2.9375	4.528	1.969	1.315	2.362	3929	32101	32590	16920	7	M10x35	8	61	4.9	6.875	6.176	5.653		
3	3.000	4.528	1.969	1.315	2.362	4012	32096	31910	16920	7	M10x35	8	61	4.9	6.875	6.176	5.653		
3 3/8	3.375	4.921	1.969	1.315	2.362	5434	38642	32430	18345	8	M10x35	8	61	5.3	7.625	6.903	6.264		
3 7/16	3.4375	5.118	1.969	1.315	2.362	5543	38700	31810	17630	8	M10x35	8	61	5.7	7.875	7.079	6.451		
3 1/2	3.500	5.118	1.969	1.315	2.362	5644	38702	31240	17630	8	M10x35	8	61	5.7	7.875	7.079	6.451		
3 3/4	3.750	5.315	1.969	1.315	2.362	7180	45952	36450	21190	10	M10x35	8	61	6.0	9.000	7.899	7.036		
3 15/16	3.9375	5.709	2.283	1.606	2.677	7957	48500	27300	16210	10	M10x35	8	61	8.2	8.500	7.680	7.059		
4	4.000	5.709	2.283	1.606	2.677	8083	48498	26870	16210	10	M10x35	8	61	8.2	8.500	7.680	7.059		

Ordering example: RfN 7013.0-IN

Series	Size
RfN 7013.0-IN	1 15/16

* B ≥ 2 l necessary

More sizes on request

■ Mounting of Locking Assembly

The Locking Assemblies are supplied slightly oiled and ready-to-use. The values for T, F_{ax}, p_W and p_N apply to installed in oiled condition.

■ Surface finishes

For shafts and hub bores

R_a = 63 RMS

■ Tolerances

We recommend the following mounting tolerances
shaft: h8 · hub: H8 - see table above

■ Change of screw tightening torques

A change of the T_A values given in the above table is inadmissible.

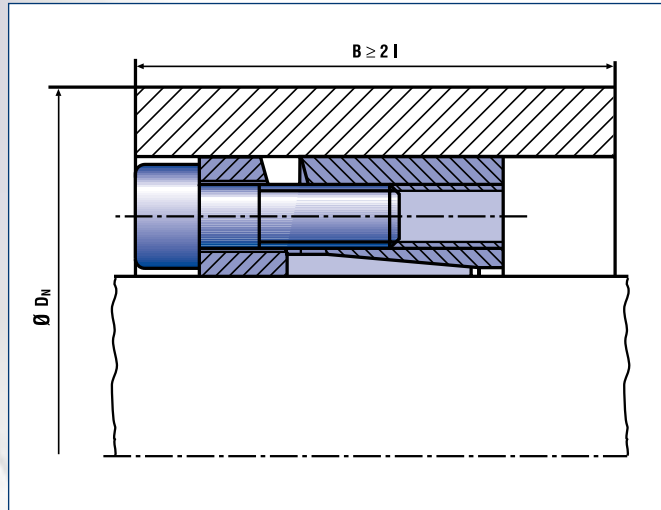
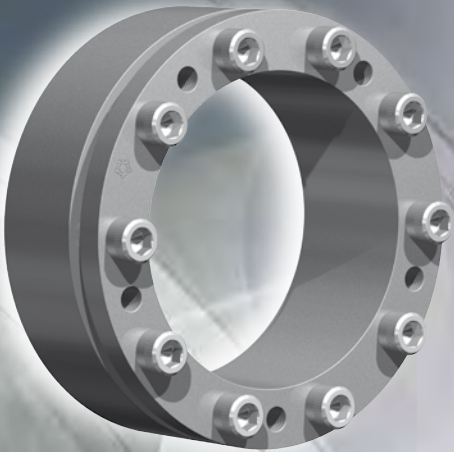

Locking Assembly RfN 7013.0 · Typical installation

Characteristics

Excellent centering ability – Due to the shallow tapered design the RfN 7013 Locking Assemblies are self-centering.

Easy trouble free assembly/removal – The reinforced flange prevents the Locking Assembly from distorting when the jacking screws are used during assembly and removal.

High rotation speed – The dimensional accuracy of the RfN 7013 Locking Assemblies allows their use in applications with higher rotational speeds.

High radial loads – The material strength of the RfN 7013 Locking Assemblies makes them especially suitable for applications with high radial loads.

Example applications:

Crane running wheels, couplings, gears, flywheels, fan blades

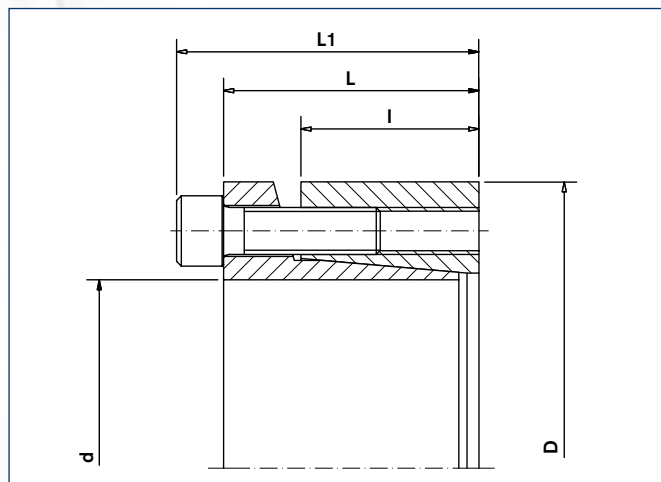

Locking Assembly RfN 7013.0 · Dimensions

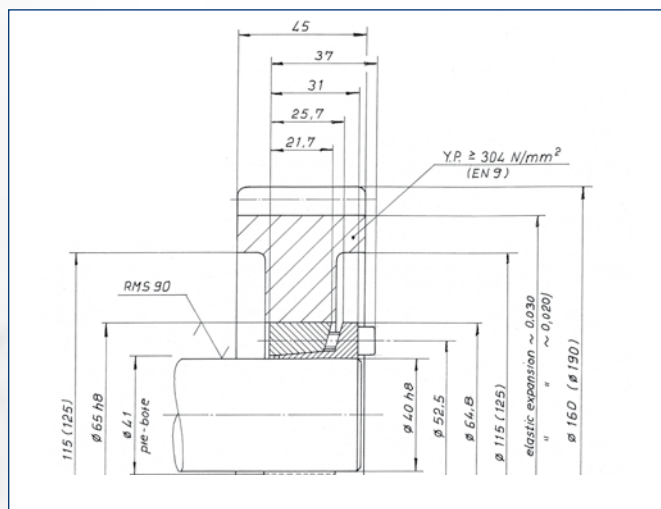

Locking Assembly RfN 7013.0 · Gear (metric example)

Locking Assembly dimensions								Transmissible torques or axial forces		Surface Pressure		Locking screws DIN EN ISO 4762-12.9			Weight	min. D _N *					
d x D	d	C ₁	D	C ₂	L	l	L ₁	T	F _{ax}	Shaft P _W	Hub P _N	n	d _G	T _A	WT	R _{p0,2} [psi]			T _{max}		
mm	Inch							lb-ft	lbs	psi			mm	lb-ft	lbs	Inch			lb-ft		
19 x 47	0.748	+0 -0.0013	1.850	-0 +0.0016	1.220	0.854	1.457	210	22129	43513	13054	4	M6 x 20	13	0.6	2.494	2.343	2.193	236		
20 x 47	0.787		1.850		1.220	0.854	1.457	221	22129	42063	13054	4	M6 x 20	13	0.6	2.494	2.343	2.193	251		
22 x 47	0.866		1.850		1.220	0.854	1.457	243	22129	37712	13054	4	M6 x 20	13	0.6	2.494	2.343	2.193	273		
24 x 50	0.945		1.969		1.220	0.854	1.457	310	29505	43513	15955	5	M6 x 20	13	0.7	2.852	2.636	2.426	354		
25 x 50	0.984		1.969		1.220	0.854	1.457	325	29505	42063	15955	5	M6 x 20	13	0.7	2.852	2.636	2.426	369		
28 x 55	1.102		2.165		1.220	0.854	1.457	361	29505	37712	14504	5	M6 x 20	13	0.8	3.024	2.819	2.616	413		
30 x 55	1.181		2.165		1.220	0.854	1.457	391	29505	34811	14504	5	M6 x 20	13	0.7	3.024	2.819	2.616	443		
32 x 60	1.260		2.362		1.220	0.854	1.457	546	36882	39162	15955	6	M6 x 20	13	0.9	3.422	3.162	2.911	627		
35 x 60	1.378	2.362	1.220	0.854	1.457	597	36882	36261	15955	6	M6 x 20	13	0.8	3.422	3.162	2.911	686				
38 x 65	1.496	2.559	1.220	0.854	1.457	656	36882	33360	14504	6	M6 x 20	13	1.0	3.575	3.331	3.093	752				
40 x 65	1.575	2.559	1.220	0.854	1.457	693	36882	31910	14504	6	M6 x 20	13	0.9	3.575	3.331	3.093	797				
42 x 75	1.654	+0 -0.0016	2.953	-0 +0.0018	1.496	0.996	1.811	1276	59011	43513	18856	6	M8 x 25	30	1.7	4.615	4.185	3.785	1461		
45 x 75	1.772		2.953		1.496	0.996	1.811	1372	59011	42063	18856	6	M8 x 25	30	1.5	4.615	4.185	3.785	1571		
48 x 80	1.890		3.150		1.496	0.996	1.811	1461	59011	39162	18856	6	M8 x 25	30	1.8	4.923	4.464	4.038	1674		
50 x 80	1.969		3.150		1.496	0.996	1.811	1527	59011	37712	18856	6	M8 x 25	30	1.7	4.923	4.464	4.038	1756		
55 x 85	2.165		3.346		1.496	0.996	1.811	1874	66387	39162	20306	7	M8 x 25	30	1.8	5.441	4.883	4.376	2154		
60 x 90	2.362		3.543		1.496	0.996	1.811	2043	66387	36261	18856	7	M8 x 25	30	1.9	5.537	5.021	4.541	2346		
65 x 95	2.559		3.740		1.496	0.996	1.811	2641	81140	37712	20306	8	M8 x 25	30	2.1	6.082	5.458	4.891	3032		
70 x 110	2.756		4.331		1.969	1.315	2.362	3762	103269	34811	18856	7	M10 x 35	61	4.6	6.769	6.138	5.552	4323		
75 x 115	2.953	4.528	1.969	1.315	2.362	4027	103269	33360	17405	7	M10 x 35	61	4.9	6.809	6.235	5.690	4625				
80 x 120	3.150	4.724	1.969	1.315	2.362	4315	103269	30459	15955	7	M10 x 35	61	5.1	6.844	6.324	5.821	4957				
85 x 125	3.346	4.921	1.969	1.315	2.362	5495	132774	33360	18856	8	M10 x 35	61	5.3	7.691	6.974	6.308	6314				
90 x 130	3.543	5.118	1.969	1.315	2.362	5827	132774	31910	17405	8	M10 x 35	61	5.7	7.697	7.047	6.432	6698				
95 x 135	3.740	+0 -0.0022	5.315	-0 +0.0025	1.969	1.315	2.362	7303	154903	37712	21757	10	M10 x 35	61	6.0	9.008	7.993	7.092	8394		
100 x 145	3.937		5.709		2.283	1.606	2.677	8114	162280	27559	15955	10	M10 x 35	61	8.2	8.270	7.642	7.035	9331		
110 x 155	4.331		6.102		2.283	1.606	2.677	8925	162280	26108	15955	10	M10 x 35	61	8.8	8.840	8.168	7.519	10261		
120 x 165	4.724		6.496		2.283	1.606	2.677	11581	191785	27559	17405	12	M10 x 35	61	9.5	9.769	8.945	8.163	13314		
130 x 180	5.118		7.087		2.559	1.787	3.031	15269	236043	27559	17405	10	M12 x 40	107	13	10.658	9.759	8.906	17556		
140 x 190	5.512		+0 -0.0025		7.480	-0 +0.0028	2.559	1.787	3.031	16597	236043	26108	15955	10	M12 x 40	107	14	10.836	10.013	9.217	19083
150 x 200	5.906				7.874		2.559	1.787	3.031	21023	280301	29009	18856	12	M12 x 40	107	15	12.306	11.159	10.093	24172

Ordering example: RfN 7013.0

* B ≥ 2 l necessary

More sizes on request

Series	d	D
RfN 7013.0	38	65

■ Mounting of Locking Assembly

The Locking Assemblies are supplied slightly oiled and ready-to-use. The values for T, F_{ax}, p_W and p_N apply to installed in oiled condition.

■ Surface finishes

For shafts and hub bores

R_a = 63 RMS

■ Tolerances

We recommend the following mounting tolerances
shaft: h8 · hub: H8 - see table above

■ Change of screw tightening torques

A change of the T_A values given in the above table is inadmissible.

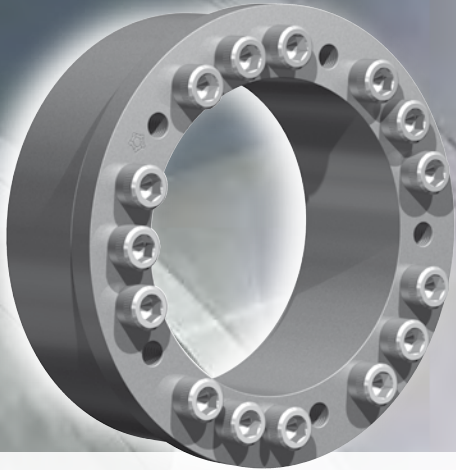

Characteristics

Excellent concentricity and very easy to remove – These Locking Assemblies provide particularly good concentricity between the clamped parts. The flange is reinforced at the critical point, preventing bending or lifting of the inner ring during assembly and thereby ensuring easy removal.

High rotation speed – The dimensional accuracy of the RfN 7013.1-IN Locking Assemblies allows their use in applications with higher rotational speeds.

High radial loads – The material strength of the RfN 7013.1-IN Locking Assemblies makes them especially suitable for applications with high radial loads.

Axial hub positioning – The increased outer diameter of the flange prevents the axial movement of the hub during assembly, and improves the run-out ability of the Locking Assembly.

High torque – The increased number of clamping screws ensures the same transmission values as the RfN 7013.1-IN.

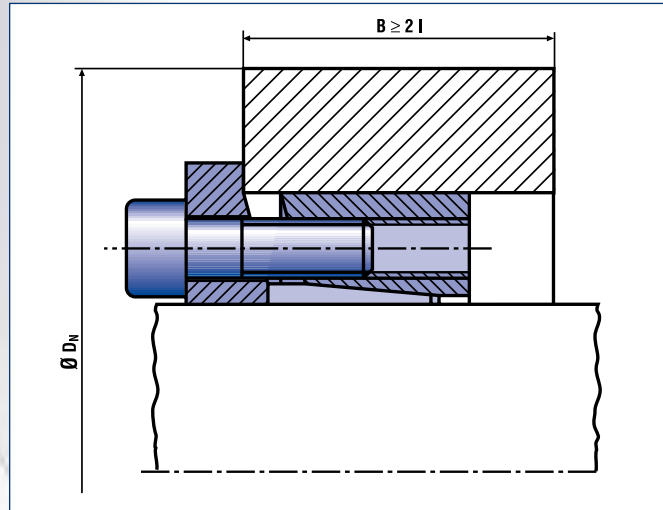

Locking Assembly RfN 7013.1-IN · Typical Installation

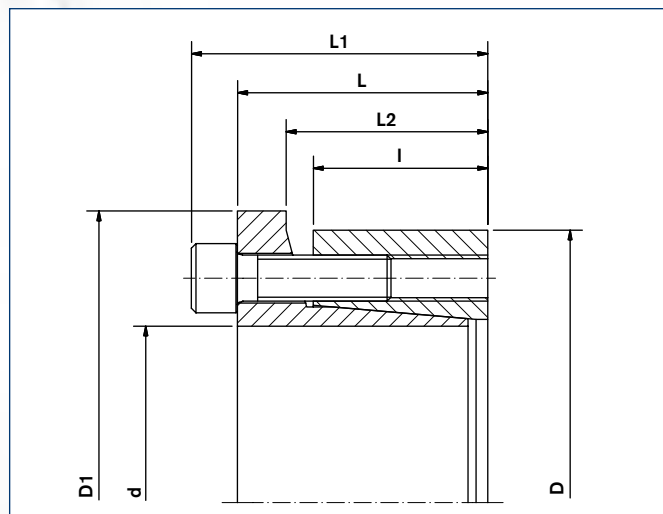

Locking Assembly RfN 7013.1-IN · Dimensions

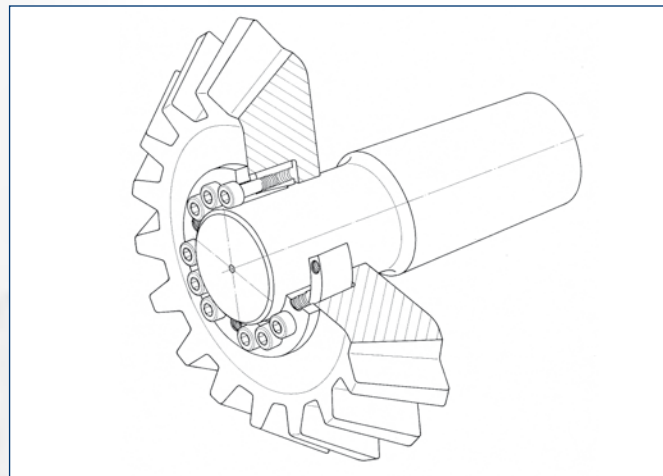

Locking Assembly RfN 7013.1-IN · Bevel gear

Size	Locking Assembly dimensions									Transmissible torques or axial forces		Surface Pressure		Locking screws DIN EN ISO 4762-12.9				Weight	min. D _N *			
	d	C ₁	D	C ₂	L	I	L ₁	L ₂	D ₁	T	F _{ax}	Shaft P _W	Hub P _N	n	d _G	s	T _A		W _T	Rp0,2[psi]		
	Inch				Inch					lb-ft	lbs	psi			mm		lb-ft	lbs	Inch			
1	1.000	+0	1.969	-0	1.220	0.854	1.457	1.012	2.205	323	7752	40170	15070	7	M6x20	5	13	0.7	2.875	2.591	2.398	
1 3/16	1.1875	-0.0013	2.165		1.220	0.854	1.457	1.012	2.441	385	7781	33800	13650	7	M6x20	5	13	0.8	3.000	2.773	2.587	
1 1/4	1.250	+0	2.362		1.220	0.854	1.457	1.012	2.677	531	10195	38560	15070	9	M6x20	5	13	0.9	3.375	3.108	2.876	
1 3/8	1.375		2.362		1.220	0.854	1.457	1.012	2.677	585	10211	35055	15070	9	M6x20	5	13	0.9	3.375	3.108	2.876	
1 7/16	1.4375		2.559		1.220	0.854	1.457	1.012	2.874	620	10351	33495	13935	10	M6x20	5	13	1.0	3.625	3.296	3.069	
1 1/2	1.500		2.559		1.220	0.854	1.457	1.012	2.874	647	10352	32100	13935	10	M6x20	5	13	1.0	3.625	3.296	3.069	
1 5/8	1.625		-0.0016		2.953	1.496	0.996	1.811	1.193	3.268	1234	18225	43870	19055	9	M8x25	6	30	1.7	4.750	4.202	3.796
1 3/4	1.750		2.953		1.496	0.996	1.811	1.193	3.268	1329	18226	40740	19055	9	M8x25	6	30	1.7	4.750	4.202	3.796	
1 7/8	1.875		3.150		1.496	0.996	1.811	1.193	3.465	1426	18253	38070	17915	9	M8x25	6	30	1.8	4.875	4.381	3.986	
1 15/16	1.9375		3.150		1.496	0.996	1.811	1.193	3.465	1473	18246	36840	17915	9	M8x25	6	30	1.8	4.875	4.381	3.986	
2	2.000		3.150	1.496	0.996	1.811	1.193	3.465	1521	18252	35690	17915	9	M8x25	6	30	1.8	4.875	4.381	3.986		
2 1/8	2.125		3.346	1.496	0.996	1.811	1.193	3.740	1803	20363	39125	19625	10	M8x25	6	30	1.8	5.500	4.816	4.335		
2 3/16	2.1875	3.346	1.496	0.996	1.811	1.193	3.740	1856	20363	38005	19625	10	M8x25	6	30	1.8	5.500	4.816	4.335			
2 1/4	2.250	3.543	1.496	0.996	1.811	1.193	3.937	1908	20352	36875	18485	10	M8x25	6	30	1.9	5.500	4.984	4.518			
2 3/8	2.375	3.543	1.496	0.996	1.811	1.193	3.937	2014	20352	34935	18485	10	M8x25	6	30	1.9	5.500	4.984	4.518			
2 7/16	2.4375	3.740	1.496	0.996	1.811	1.193	4.134	2466	24281	38965	20050	12	M8x25	6	30	2.1	6.125	5.430	4.873			
2 1/2	2.500	-0.0018	3.740	1.496	0.996	1.811	1.193	4.134	2530	24288	37990	20050	12	M8x25	6	30	2.1	6.125	5.430	4.873		
2 9/16	2.5625	3.740	1.496	0.996	1.811	1.193	4.134	2593	24286	37065	20050	12	M8x25	6	30	2.1	6.125	5.430	4.873			
2 3/4	2.750	4.331	1.969	1.315	2.362	1.591	4.724	3680	32116	34770	18200	10	M10x35	8	61	4.6	6.750	6.058	5.502			
2 7/8	2.875	4.528	1.969	1.315	2.362	1.591	4.921	3845	32097	33300	16920	10	M10x35	8	61	4.9	6.875	6.176	5.653			
2 15/16	2.9375	4.528	1.969	1.315	2.362	1.591	4.921	3929	32101	32590	16920	10	M10x35	8	61	4.9	6.875	6.176	5.653			
3	3.000	4.528	1.969	1.315	2.362	1.591	4.921	4012	32096	31910	16920	10	M10x35	8	61	4.9	6.875	6.176	5.653			
3 3/8	3.375	4.921	1.969	1.315	2.362	1.591	5.315	5434	38642	32430	18345	12	M10x35	8	61	5.3	7.625	6.903	6.264			
3 7/16	3.4375	5.118	1.969	1.315	2.362	1.591	5.512	5543	38700	31810	17630	12	M10x35	8	61	5.7	7.875	7.079	6.451			
3 1/2	3.500	+0	5.118	-0	1.969	1.315	2.362	1.591	5.512	5644	38702	31240	17630	12	M10x35	8	61	5.7	7.875	7.079	6.451	
3 3/4	3.750	-0.0022	5.315		1.969	1.315	2.362	1.591	5.709	7180	45952	36450	21190	15	M10x35	8	61	6.0	9.000	7.899	7.036	
3 15/16	3.9375	5.709	2.283		1.606	2.677	1.882	6.102	7957	48500	27300	16210	15	M10x35	8	61	8.2	8.500	7.680	7.059		
4	4.000	5.709	2.283		1.606	2.677	1.882	6.102	8083	48498	26870	16210	15	M10x35	8	61	8.2	8.500	7.680	7.059		

Ordering example: RfN 7013.1-IN

Series	Size
RfN 7013.1-IN	1 7/8

* B ≥ 2 l necessary

More sizes on request

■ Mounting of Locking Assembly

The Locking Assemblies are supplied slightly oiled and ready-to-use. The values for T, F_{ax}, p_W and p_N apply to installed in oiled condition.

■ Surface finishes

For shafts and hub bores

R_a = 63 RMS

■ Tolerances

We recommend the following mounting tolerances

shaft: h8 · hub: H8 - see table above

■ Location of several Locking Assemblies RfN 7013.1-IN

Location only possible from 2 sides. If several Locking Assemblies are used to increase the transmission values the clamping systematization has to be considered.

■ Change of screw tightening torques

A change of the T_A values given in the above table is not admissible.

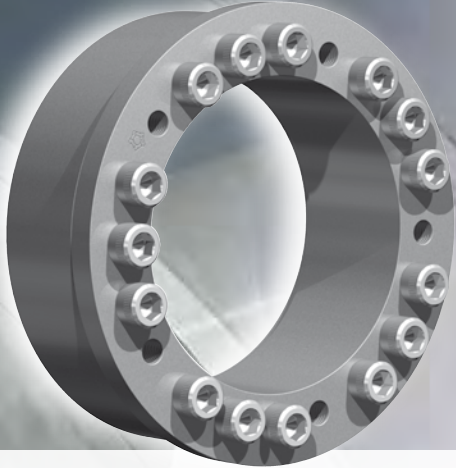

Characteristics

Excellent concentricity and very easy to remove – These Locking Assemblies provide particularly good concentricity between the clamped parts. The flange is reinforced at the critical point, preventing bending or lifting of the inner ring during assembly and thereby ensuring easy removal.

High rotation speed – The dimensional accuracy of the RfN 7013 Locking Assemblies allows their use in applications with higher rotational speeds.

High radial loads – The material strength of the RfN 7013 Locking Assemblies makes them especially suitable for applications with high radial loads.

Axial hub positioning – The increased outer diameter of the flange prevents the axial movement of the hub during assembly, and improves the run-out ability of the Locking Assembly.

High torque – The increased number of clamping screws ensures the same transmission values as the RfN 7013.0.

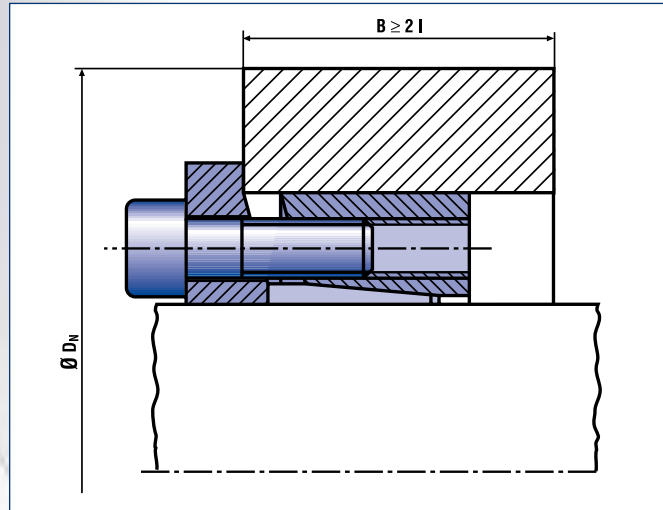

Locking Assembly RfN 7013.1 · Typical Installation

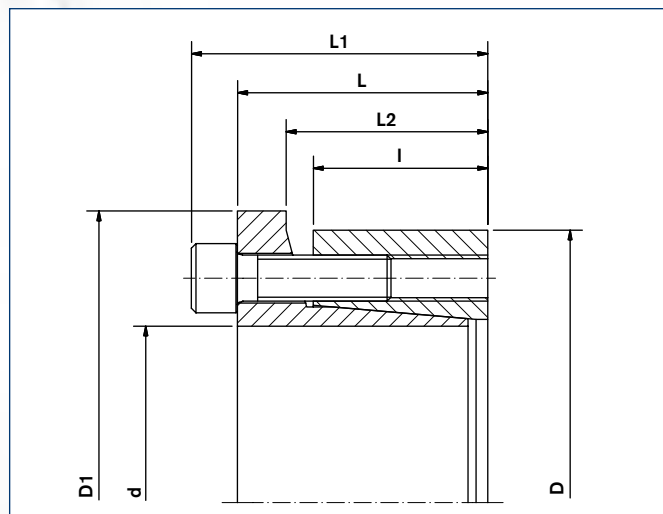

Locking Assembly RfN 7013.1 · Dimensions

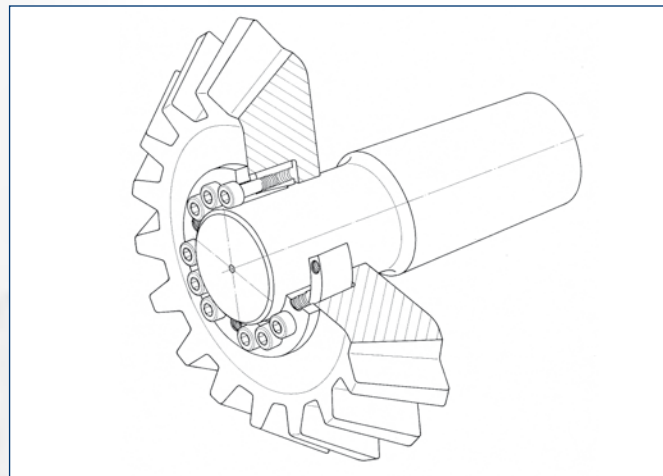

Locking Assembly RfN 7013.1 · Bevel gear

Locking Assembly dimensions									Transmissible torques or axial forces		Surface Pressure		Locking screws DIN EN ISO 4762-12.9			Weight	min. D _N *				
d x D	d	C ₁	D	C ₂	L	l	L ₁	L ₂	D ₁	T	F _{ax}	Shaft P _W	Hub P _N	n	d _G	T _A	W _T	Rp0,2[psi]			T _{max}
mm	Inch								lb-ft	lbs	psi			mm	lb-ft	lbs	Inch			lb-ft	
19 x 47	0.748		1.850		1.220	0.854	1.457	1.012	2.087	210	6745	43513	13054	6	M 6 x 20	13	0.6	2.494	2.343	2.193	229
20 x 47	0.787		1.850	-0	1.220	0.854	1.457	1.012	2.087	221	6745	42063	13054	6	M 6 x 20	13	0.6	2.494	2.343	2.193	243
22 x 47	0.866		1.850	+0.0016	1.220	0.854	1.457	1.012	2.087	243	6745	37712	13054	6	M 6 x 20	13	0.6	2.494	2.343	2.193	266
24 x 50	0.945	+0	1.969		1.220	0.854	1.457	1.012	2.205	310	8993	43513	15955	7	M 6 x 20	13	0.7	2.852	2.636	2.426	339
25 x 50	0.984	-0.0013	1.969		1.220	0.854	1.457	1.012	2.205	325	8993	42063	15955	7	M 6 x 20	13	0.7	2.852	2.636	2.426	354
28 x 55	1.102		2.165		1.220	0.854	1.457	1.012	2.441	361	8993	37712	14504	7	M 6 x 20	13	0.8	3.024	2.819	2.616	391
30 x 55	1.181		2.165		1.220	0.854	1.457	1.012	2.441	391	8993	34811	14504	7	M 6 x 20	13	0.7	3.024	2.819	2.616	428
32 x 60	1.260		2.362		1.220	0.854	1.457	1.012	2.677	546	11241	39162	15955	9	M 6 x 20	13	0.9	3.422	3.162	2.911	597
35 x 60	1.378		2.362		1.220	0.854	1.457	1.012	2.677	597	11241	36261	15955	9	M 6 x 20	13	0.8	3.422	3.162	2.911	656
38 x 65	1.496		2.559	-0	1.220	0.854	1.457	1.012	2.874	656	11241	33360	14504	10	M 6 x 20	13	1.0	3.575	3.331	3.093	716
40 x 65	1.575	+0	2.559	+0.0018	1.220	0.854	1.457	1.012	2.874	693	11241	31910	14504	10	M 6 x 20	13	0.9	3.575	3.331	3.093	760
42 x 75	1.654	-0.0016	2.953		1.496	0.996	1.811	1.193	3.268	1276	17986	43513	18856	9	M 8 x 25	30	1.7	4.615	4.185	3.785	1402
45 x 75	1.772		2.953		1.496	0.996	1.811	1.193	3.268	1372	17986	40613	18856	9	M 8 x 25	30	1.5	4.615	4.185	3.785	1505
48 x 80	1.890		3.150		1.496	0.996	1.811	1.193	3.465	1461	17986	39162	18856	9	M 8 x 25	30	1.8	4.923	4.464	4.038	1601
50 x 80	1.969		3.150		1.496	0.996	1.811	1.193	3.465	1527	17986	37712	18856	9	M 8 x 25	30	1.7	4.923	4.464	4.038	1674
55 x 85	2.165		3.346		1.496	0.996	1.811	1.193	3.740	1874	20234	39162	20306	10	M 8 x 25	30	1.8	5.441	4.883	4.376	2058
60 x 90	2.362		3.543		1.496	0.996	1.811	1.193	3.937	2043	20234	36261	18856	10	M 8 x 25	30	1.9	5.537	5.021	4.541	2242
65 x 95	2.559	+0	3.740	-0	1.496	0.996	1.811	1.193	4.134	2641	24730	37712	20306	12	M 8 x 25	30	2.1	6.082	5.458	4.891	2899
70 x 110	2.756	-0.0018	4.331	+0.0022	1.969	1.315	2.362	1.591	4.724	3762	31475	34811	18856	10	M 10 x 35	61	4.6	6.769	6.138	5.552	4138
75 x 115	2.953		4.528		1.969	1.315	2.362	1.591	4.921	4027	31475	33360	17405	10	M 10 x 35	61	4.9	6.809	6.235	5.690	4426
80 x 120	3.150		4.724		1.969	1.315	2.362	1.591	5.118	4315	31475	30459	15955	10	M 10 x 35	61	5.1	6.844	6.324	5.821	4743
85 x 125	3.346		4.921		1.969	1.315	2.362	1.591	5.315	5495	40468	33360	18856	12	M 10 x 35	61	5.3	7.691	6.974	6.308	6041
90 x 130	3.543		5.118		1.969	1.315	2.362	1.591	5.512	5827	40468	31910	17405	12	M 10 x 35	61	5.7	7.697	7.047	6.432	6410
95 x 135	3.740	+0	5.315	-0	1.969	1.315	2.362	1.591	5.709	7303	47212	37712	21757	15	M 10 x 35	61	6.0	9.008	7.993	7.092	8033
100 x 145	3.937	-0.0022	5.709	+0.0025	2.283	1.606	2.677	1.882	6.102	8114	49460	27559	15955	15	M 10 x 35	61	8.2	8.270	7.642	7.035	8925
110 x 155	4.331		6.102		2.283	1.606	2.677	1.882	6.496	8925	49460	26108	15955	15	M 10 x 35	61	8.8	8.840	8.168	7.519	9818
120 x 165	4.724		6.496		2.283	1.606	2.677	1.882	6.890	11581	58453	27559	17405	18	M 10 x 35	61	9.5	9.769	8.945	8.163	12739
130 x 180	5.118		7.087		2.559	1.787	3.031	2.063	7.480	15269	71942	27559	17405	15	M 12 x 40	107	13	10.658	9.759	8.906	16796
140 x 190	5.512	+0	7.480	-0	2.559	1.787	3.031	2.063	7.874	16597	71942	26108	15955	15	M 12 x 40	107	14	10.836	10.013	9.217	18256
150 x 200	5.906	-0.0025	7.874	+0.0028	2.559	1.787	3.031	2.063	8.268	21023	85432	29009	18856	18	M 12 x 40	107	15	12.306	11.159	10.093	23125

Ordering example: RfN 7013.1

Series	d	D
RfN 7013.1	35	60

* B ≥ 2 l necessary

More sizes on request

■ Mounting of Locking Assembly

The Locking Assemblies are supplied slightly oiled and ready-to-use. The values for T, F_{ax}, p_W and p_N apply to installed in oiled condition.

■ Surface finishes

For shafts and hub bores

R_a = 63 RMS

■ Tolerances

We recommend the following mounting tolerances

shaft: h8 · hub: H8 - see table above

■ Location of several Locking Assemblies RfN 7013.1

Location only possible from 2 sides. If several Locking Assemblies are used to increase the transmission values the clamping systematization has to be considered.

■ Change of screw tightening torques

A change of the T_A values given in the above table is inadmissible.

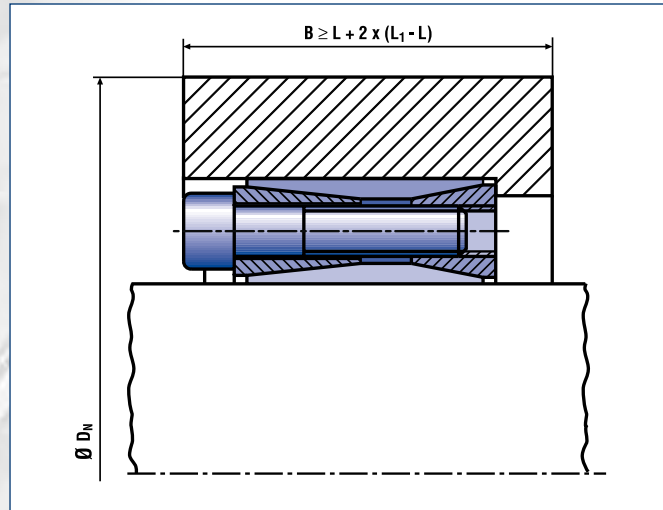
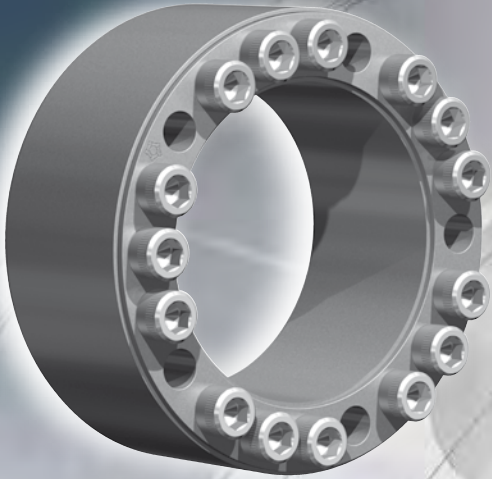

Locking Assembly RfN 7014 Typical installation

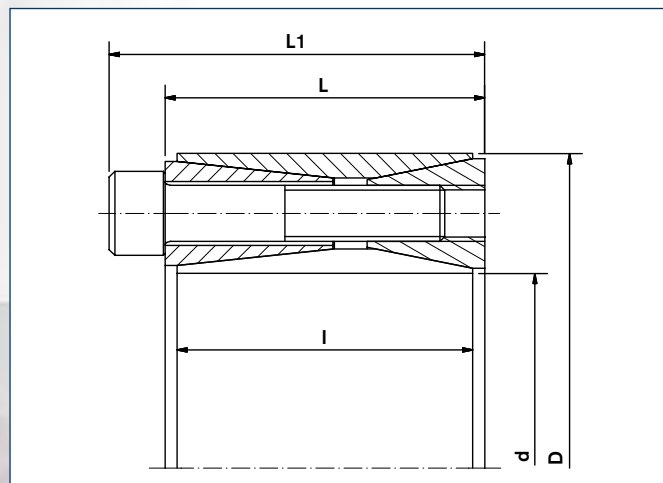

Locking Assembly RfN 7014 · Dimensions

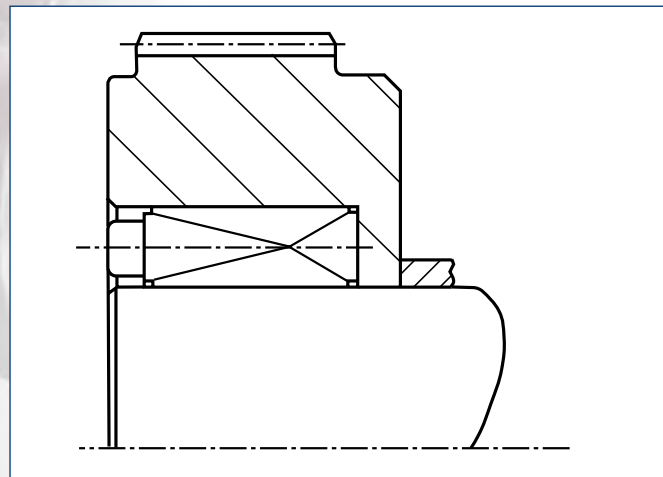

Locking Assembly RfN 7014 · Mounting of Gear

Characteristics

Large transmission of peripheral forces – Due to the long, flat tapers it is possible to transmit maximum torques and axial forces with **one** RfN 7014 locking assembly.

Maximum reliability – Due to the shallow tapers and the relatively wide construction (large guide lengths) the Locking Assemblies RfN 7014 center themselves. During installation, the Locking Assembly, shaft and hub remain in position relative to each other. The shaft and hub are subject to pure clamping pressure, providing additional safety compared to 3 piece designs.

Example applications:

Heavy pulleys, construction of heavy machinery, couplings, cable sheaves

Locking Assembly dimensions								Transmissible torques or axial forces		Surface Pressure		Locking screws DIN EN ISO 4762-12.9			Weight	min. D _N *			
d x D	d	C ₁	D	C ₂	L	I	L ₁	T	F _{ax}	Shaft p _w	Hub p _N	n	Thread d _G	T _A	WT	Rp0,2[psi]			
mm	Inch							lb-ft	lbs	psi			mm	lb-ft	lbs	36000 45000 62000			
																Inch			
70 x 120	2.756	+0	4.724	-0	2.441	2.205	2.913	5053	44964	29009	17405	8	M 12 x 55	107	7.3	7.104	6.505	5.937	5827
80 x 130	3.150	-0.003	5.118	+0.003	2.441	2.205	2.913	8593	65198	37712	23207	12	M 12 x 55	107	8.2	9.054	7.936	6.970	9958
90 x 140	3.543		5.512		2.441	2.205	2.913	9589	65198	33360	21757	12	M 12 x 55	107	8.8	9.341	8.289	7.355	11138
100 x 160	3.937	+0	6.299	-0	3.150	2.913	3.701	14531	87680	30459	18856	12	M 14 x 70	170	16	9.844	8.927	8.074	17113
110 x 170	4.331	-0.0035	6.693	+0.0035	3.150	2.913	3.701	19621	110162	34811	23207	14	M 14 x 70	170	17	11.841	10.379	9.115	21760
120 x 180	4.724		7.087		3.150	2.913	3.701	21318	107914	31910	21757	15	M 14 x 70	170	18	12.011	10.658	9.457	25670
130 x 190	5.118		7.480		3.150	2.913	3.701	23014	107914	30459	20306	15	M 14 x 70	170	19	12.164	10.916	9.782	27809
140 x 200	5.512		7.874		3.150	2.913	3.701	29653	128147	33360	23207	17	M 14 x 70	170	21	13.930	12.210	10.724	33931
150 x 210	5.906	+0	8.268	-0	3.150	2.913	3.701	31645	128147	30459	21757	18	M 14 x 70	170	22	14.012	12.434	11.033	38505
160 x 230	6.299	-0.004	9.055	+0.004	3.701	3.465	4.331	47209	179856	33360	23207	17	M 16 x 80	262	33	16.019	14.042	12.332	52446
170 x 240	6.693		9.449		3.701	3.465	4.331	50012	179856	30459	21757	18	M 16 x 80	262	35	16.013	14.210	12.609	59011
180 x 250	7.087		9.843		3.701	3.465	4.331	61224	206835	34811	24658	20	M 16 x 80	262	36	18.214	15.752	13.686	69411
190 x 260	7.480		10.236		3.701	3.465	4.331	64912	206835	31910	23207	21	M 16 x 80	262	38	18.109	15.873	13.941	76935
200 x 270	7.874	+0	10.630	-0	3.701	3.465	4.331	77452	236061	34811	26108	23	M 16 x 80	262	41	20.623	17.571	15.093	88664
220 x 300	8.661	-0.0045	11.811	+0.0045	4.567	4.331	5.276	90729	251799	27559	20306	21	M 18 x 100	358	61	19.208	17.237	15.445	108875
240 x 320	9.449		12.598		4.567	4.331	5.276	112858	287770	29009	21757	24	M 18 x 100	358	66	21.350	18.945	16.811	135725
260 x 340	10.236		13.386		4.567	4.331	5.276	137200	321493	29009	23207	26	M 18 x 100	358	71	23.682	20.758	18.231	159329
280 x 370	11.024	+0	14.567	-0	5.354	5.118	6.142	169656	370953	27559	21757	24	M 20 x 120	509	101	24.687	21.906	19.438	201374
300 x 390	11.811	-0.005	15.354	+0.005	5.354	5.118	6.142	180721	370953	26108	20306	24	M 20 x 120	509	108	24.969	22.408	20.078	215758

Ordering example: RfN 7014

* B ≥ L+2x (L1-L) necessary

More sizes on request

Series	d	D
RfN 7014	120	180

■ Mounting of Locking Assembly

The values for T, F_{ax}, p_w and p_N apply to Locking Assemblies installed in oiled condition.

■ Surface finishes

For shafts and hub bores

R_a ≤ 125 RMS

■ Tolerances

We recommend the following mounting tolerances

shaft: k9-h9 · hub: N9-H9 - see table above

■ Location of several Locking Assemblies RfN 7014

Two Locking Assemblies at most can be installed in series. In this case the transmission values of the above table will be double.

Note: For the removal of the Locking Assembly a step in the hub or shaft is required (see location drawing page 18).

■ Change of screw tightening torques

A reduction of the contact pressures and the transmission values by reducing the tightening torque of the screws is possible. The admissible lower limit is a 20% reduction of tightening torque. There is an approximate linear relationship between T, T_A, F_{ax}, p_w and p_N

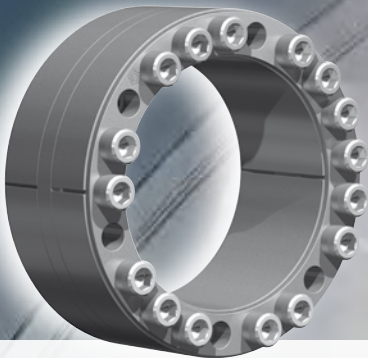

Characteristics

Precision Locking Assembly for the transmission of maximum torques and axial forces with special requirements for the concentricity of the parts being clamped, as well as for applications subjected to bending moments.

Large transmission of peripheral forces – Due to the long, flat tapers it is possible to transmit maximum torques and axial forces with one RfN 7015.0 Locking Assembly.

⚠ Bending moment and radial loads – Combined loads can be transmitted (Please contact our specialists for assistance). During installation, the Locking Assembly, shaft and hub remain positioned relative to one another. Compared to 3-part versions, an additional safety is provided. Shaft and hub are only compression-loaded.

Excellent centering ability – With a relatively wide design (giving increased guiding lengths) and the precentering web, the RfN 7015.0 Locking Assembly has excellent centering ability.

Example applications:

Belt drums, crusher rotors, precision drives

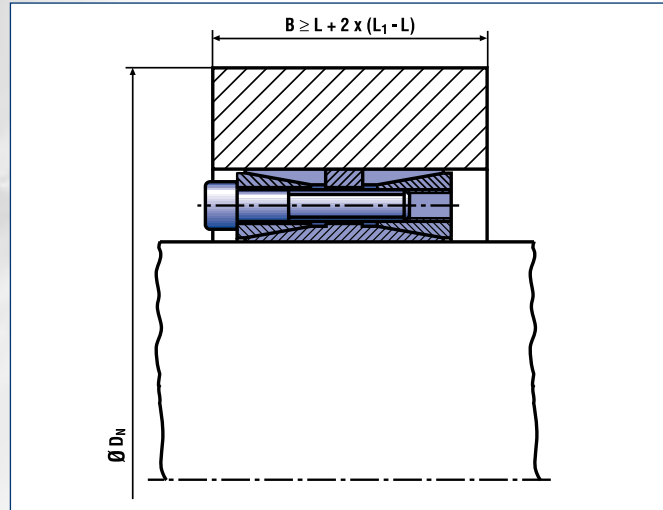

Locking Assembly RfN 7015.0 · Typical installation

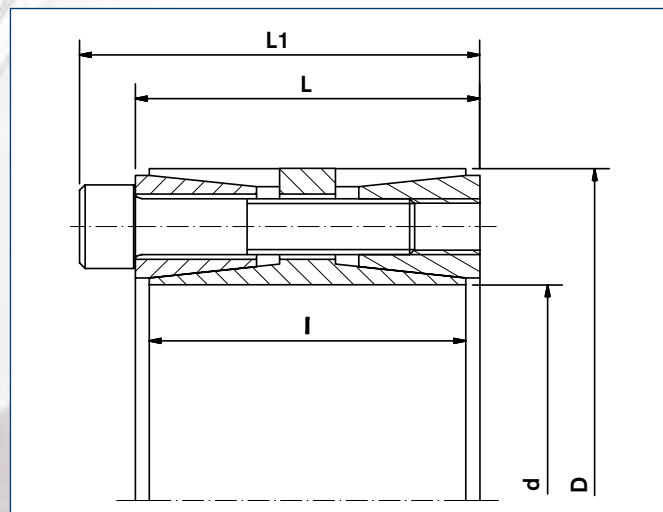

Locking Assembly RfN 7015 · Dimensions

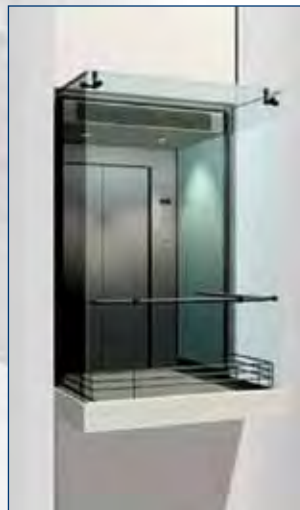

Drive unit for high-speed elevator

Locking Assembly dimensions									Transmissible torques or axial forces		Surface Pressure		Locking screws DIN EN ISO 4762-12.9			Weight	min. D _N *		
d x D	d	C ₁	D	C ₂	L	I	L ₁	T	F _{ax}	Shaft p _w	Hub p _N	n	Thread d _G	T _A	WT	Rp0,2[psi] 36000 45000 62000			T _{max}
mm	Inch							lb-ft	lbs	psi			mm	lb-ft	lbs	Inch			lb-ft
100 x 145	3.937		5.709		2.559	2.362	3.031	10622	65198	27559	18856	10	M 12 x 55	107	9.0	8.922	8.091	7.318	12540
110 x 155	4.331	+0 -0.0021	6.102	-0 +0.0021	2.559	2.362	3.031	11692	65198	26108	17405	10	M 12 x 55	107	9.7	9.176	8.403	7.668	13868
120 x 165	4.724		6.496		2.559	2.362	3.031	15306	78687	27559	20306	12	M 12 x 55	107	11	10.564	9.480	8.495	18146
130 x 180	5.118		7.087		2.913	2.677	3.386	20728	96673	27559	20306	15	M 12 x 60	107	14	11.525	10.343	9.268	24342
140 x 190	5.512		7.480		2.913	2.677	3.386	26776	116906	30459	23207	18	M 12 x 60	107	15	13.233	11.599	10.187	31718
150 x 200	5.906		7.874		2.913	2.677	3.386	28768	116906	29009	21757	18	M 12 x 60	107	16	13.344	11.841	10.507	34005
160 x 210	6.299	-0.0025	8.268	+0.0025	2.913	2.677	3.386	35775	134892	31910	24658	21	M 12 x 60	107	17	15.300	13.231	11.496	42340
170 x 225	6.693		8.858		3.189	2.953	3.740	44701	159622	31910	23207	18	M 14 x 65	170	22	15.671	13.736	12.064	53183
180 x 235	7.087		9.252		3.189	2.953	3.740	47282	159622	29009	23207	18	M 14 x 65	170	23	16.368	14.347	12.601	56282
190 x 250	7.480		9.843		3.701	3.465	4.252	55470	177608	26108	20306	20	M 14 x 75	170	32	16.007	14.365	12.872	66018
200 x 260	7.874	+0	10.236	-0	3.701	3.465	4.252	70075	213579	29009	23207	24	M 14 x 75	170	33	18.109	15.873	13.941	83427
220 x 285	8.661	-0.0028	11.220	+0.0028	4.094	3.858	4.724	80402	222572	26108	20306	18	M 16 x 90	262	44	18.246	16.375	14.672	93090
240 x 305	9.449		12.008		4.094	3.858	4.724	116546	296763	31910	26108	24	M 16 x 90	262	47	23.297	19.849	17.050	135430
260 x 325	10.236		12.795		4.094	3.858	4.724	131299	308004	31910	24658	25	M 16 x 90	262	51	23.677	20.476	17.790	152764
280 x 355	11.024	+0 -0.0032	13.976	-0 +0.0032	4.961	4.724	5.669	164124	357464	27559	21757	24	M 18 x 110	358	78	23.685	21.018	18.649	193187
300 x 375	11.811		14.764		4.961	4.724	5.669	182933	370953	26108	21757	25	M 18 x 110	358	82	25.021	22.203	19.701	215611
320 x 405	12.598		15.945		5.591	5.315	6.378	253746	481115	27559	21757	25	M 20 x 120	509	113	27.022	23.979	21.277	292325
340 x 425	13.386		16.732		5.591	5.315	6.378	269237	481115	26108	20306	25	M 20 x 120	509	119	27.210	24.419	21.880	310618
360 x 455	14.173	+0 -0.0035	17.913	-0 +0.0035	6.496	6.220	7.362	354065	600270	26108	20306	25	M 22 x 130	686	166	29.131	26.143	23.425	406216
380 x 475	14.961		18.701		6.496	6.220	7.362	374719	600270	24658	18856	25	M 22 x 130	686	174	29.227	26.503	23.971	428787
400 x 495	15.748		19.488		6.496	6.220	7.362	394635	600270	23207	20306	25	M 22 x 130	686	183	31.692	28.441	25.485	451359
420 x 515	16.535		20.276		6.496	6.220	7.362	496797	719424	26108	21757	30	M 22 x 130	686	191	34.362	30.492	27.056	568717
440 x 545	17.323		21.457		7.087	6.772	8.031	601172	831835	26108	20306	30	M 24 x 150	885	243	34.894	31.315	28.059	700458
460 x 565	18.110	+0 -0.0038	22.244	-0 +0.0038	7.087	6.772	8.031	628465	831835	24658	20306	30	M 24 x 150	885	251	36.174	32.463	29.089	732324
480 x 585	18.898		23.031		7.087	6.772	8.031	699278	888040	26108	20306	32	M 24 x 150	885	262	37.454	33.612	30.118	815087
500 x 605	19.685		23.819		7.087	6.772	8.031	728783	888040	24658	20306	32	M 24 x 150	885	271	38.735	34.762	31.148	822537
520 x 630	20.472		24.803		7.874	7.480	8.937	829102	971223	23207	18856	30	M 27 x 160	1180	326	38.763	35.151	31.793	993225
540 x 650	21.26		25.591		7.874	7.480	8.937	860820	971223	21757	18856	30	M 27 x 160	1180	340	39.995	36.268	32.803	1031435
560 x 670	22.047	+0 -0.0041	26.378	-0 +0.0041	7.874	7.480	8.937	892538	971223	21757	17405	30	M 27 x 160	1180	353	39.668	36.323	33.149	1069644
580 x 690	22.835		27.165		7.874	7.480	8.937	924257	971223	20306	17405	30	M 27 x 160	1180	364	40.852	37.406	34.138	1107854
600 x 710	23.622		27.953		7.874	7.480	8.937	1017936	1036421	21757	17405	32	M 27 x 160	1180	375	42.037	38.492	35.128	1222482

Ordering example: RfN 7015.0

* B_z ≥ L+2x (L1-L) necessary

More sizes on request

Series	d	D
RfN 7015.0	440	545

■ Mounting of Locking Assembly

The values for T, F_{ax}, p_w and p_N apply to Locking Assemblies installed in oiled condition.

■ Surface finishes

For shafts and hub bores

R_a ≤ 125 RMS

■ Tolerances

We recommend the following mounting tolerances

shaft: h8 · : H8 - see table above

■ Location of several Locking Assemblies RfN 7015.0

Two RfN 7015 Locking Assemblies can be used in series, the transmissible torques and axial forces are added.

■ Change of screw tightening torques

A reduction of the contact pressures and the transmission values by reducing the tightening torque of the screws is possible. The admissible lower limit is a 20% reduction of tightening torque. There is an approximate linear relationship between T, T_A, F_{ax}, p_w and p_N.

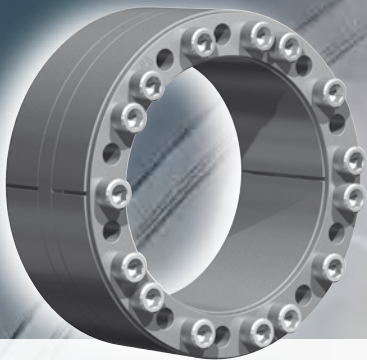

Characteristics

Locking Assembly for transmission of torques, axial forces and high bending moments at reduced contact pressures, with special requirements for concentricity of connected components

Low surface pressures – The RfN 7015.1 Locking Assembly can transmit torques and axial forces and bending loads with significantly lower surface pressures.

⚠ Bending moment and radial loads – Combined loads can be transmitted, please contact our specialists for assistance.

Excellent centering ability – With a relatively wide design (giving increased guiding lengths) and the precentering web, the RfN 7015.1 Locking Assembly has excellent centering ability.

Example applications:

Conveyor pulleys, gears

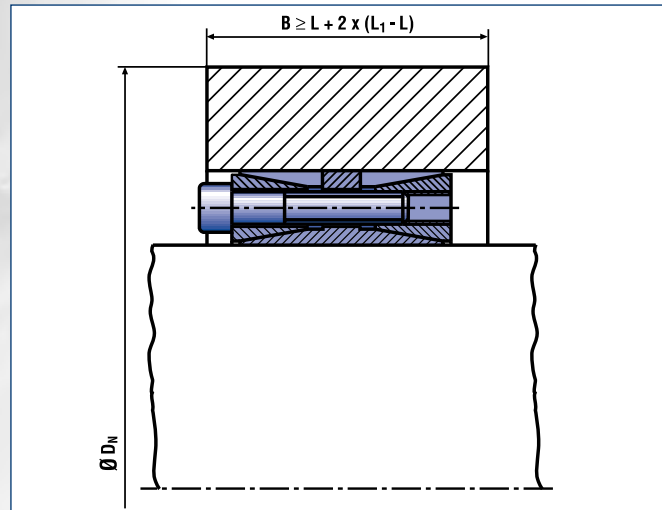

Locking Assembly RfN 7015.1 · Typical installation

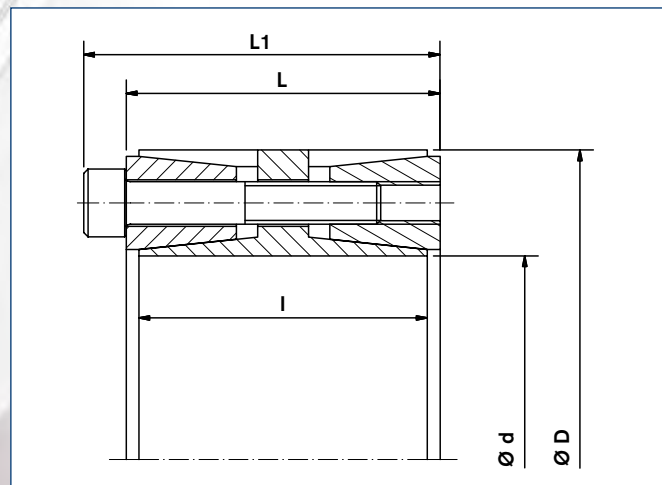

Locking Assembly RfN 7015.1 · Dimensions



Jaw crusher

Locking Assembly dimensions									Transmissible torques or axial forces		Surface Pressure		Locking screws DIN EN ISO 4762-12.9			Weight	min. D _N *		
d x D	d	C ₁	D	C ₂	L	l	L ₁	T	F _{ax}	Shaft p _w	Hub p _N	n	Thread d _G	T _A	WT	Rp0,2[psi] 36000 45000 62000			T _{max}
mm	Inch							lb-ft	lbs	psi			mm	lb-ft	lbs	Inch			lb-ft
100 x 145	3.937		5.709		2.559	2.362	2.953	4942	29227	13054	8703	9	M10 x 55	61	9.0	6.944	6.673	6.390	5680
110 x 155	4.331	+0 -0.0021	6.102	-0 +0.0021	2.559	2.362	2.953	6049	33723	13054	8703	10	M10 x 55	61	9.7	7.422	7.132	6.830	6934
120 x 165	4.724		6.496		2.559	2.362	2.953	7893	40468	14504	10153	12	M10 x 55	61	11	8.172	7.797	7.411	9073
130 x 180	5.118		7.087		2.913	2.677	3.307	10696	49460	13054	10153	15	M10 x 60	61	14	8.916	8.506	8.085	12319
140 x 190	5.512		7.480		2.913	2.677	3.307	11544	49460	13054	8703	15	M10 x 60	61	15	9.098	8.743	8.373	13277
150 x 200	5.906		7.874	-0 +0.0025	2.913	2.677	3.307	13277	53957	13054	8703	16	M10 x 60	61	16	9.578	9.203	8.814	15195
160 x 210	6.299	+0 -0.0025	8.268		2.913	2.677	3.307	16228	62950	13054	10153	18	M10 x 60	61	17	10.402	9.923	9.432	18220
170 x 225	6.693		8.858		3.189	2.953	3.661	20432	74191	13054	10153	15	M12 x 65	107	22	11.144	10.631	10.106	24194
180 x 235	7.087		9.252		3.189	2.953	3.661	23014	78687	13054	10153	16	M12 x 65	107	23	11.640	11.104	10.555	27292
190 x 250	7.480		9.843		3.701	3.465	4.173	27366	87680	11604	8703	18	M12 x 75	107	32	11.973	11.504	11.018	32456
200 x 260	7.874	+0	10.236	-0	3.701	3.465	4.173	32013	96673	13054	10153	20	M12 x 75	107	33	12.878	12.285	11.678	37914
220 x 285	8.661	-0.0028	11.220	+0.0028	4.094	3.858	4.567	40570	112410	11604	8703	21	M12 x 80	107	44	13.648	13.114	12.559	43816
240 x 305	9.449		12.008		4.094	3.858	4.567	51634	130396	13054	10153	24	M12 x 80	107	47	15.107	14.412	13.699	54659
260 x 325	10.236		12.795		4.094	3.858	4.567	66387	155126	13054	10153	27	M12 x 80	107	51	16.097	15.357	14.597	66608
280 x 355	11.024	+0 -0.0032	13.976	-0 +0.0032	4.961	4.724	5.512	88516	186601	13054	10153	28	M14 x 100	170	78	17.583	16.774	15.944	102605
300 x 375	11.811		14.764		4.961	4.724	5.512	92204	186601	13054	10153	28	M14 x 100	170	82	18.574	17.720	16.843	109981
320 x 405	12.598		15.945		5.591	5.315	6.220	137053	260791	14504	11604	28	M16 x 110	262	113	20.759	19.657	18.541	158592
340 x 425	13.386		16.732		5.591	5.315	6.220	147527	260791	13054	10153	28	M16 x 110	262	119	21.050	20.082	19.089	168550
360 x 455	14.173	+0 -0.0035	17.913	-0 +0.0035	6.496	6.220	7.205	158739	269784	10153	8703	24	M18 x 140	358	166	21.789	20.936	20.051	187064
380 x 475	14.961		18.701		6.496	6.220	7.205	188835	303507	11604	8703	27	M18 x 140	358	174	22.747	21.858	20.933	222102
400 x 495	15.748		19.488		6.496	6.220	7.205	236043	359712	13054	10153	32	M18 x 140	358	183	24.517	23.390	22.233	277129
420 x 515	16.535		20.276		6.496	6.220	7.205	258172	359712	13054	10153	32	M18 x 140	358	191	25.509	24.336	23.132	290923
440 x 545	17.323		21.457		7.087	6.772	7.874	289891	402428	11604	10153	27	M20 x 140	509	243	26.994	25.753	24.479	326920
460 x 565	18.110	+0 -0.0038	22.244	-0 +0.0038	7.087	6.772	7.874	303537	402428	11604	8703	27	M20 x 140	509	251	27.057	25.999	24.899	341820
480 x 585	18.898		23.031		7.087	6.772	7.874	343000	433903	11604	10153	30	M20 x 140	509	262	28.975	27.642	26.275	396331
500 x 605	19.685		23.819		7.087	6.772	7.874	357753	433903	11604	10153	30	M20 x 140	509	271	29.966	28.588	27.174	412854
520 x 630	20.472		24.803		7.874	7.480	8.661	396848	465378	10153	8703	32	M20 x 150	509	326	30.169	28.989	27.764	457998
540 x 650	21.260		25.591		7.874	7.480	8.661	413076	465378	10153	8703	32	M20 x 150	509	340	31.128	29.910	28.646	475553
560 x 670	22.047		26.378		7.874	7.480	8.661	480200	521583	11604	10153	36	M20 x 150	509	353	33.185	31.659	30.093	554849
580 x 690	22.835	+0 -0.0041	27.165	-0 +0.0041	7.874	7.480	8.661	498641	521583	10153	8703	36	M20 x 150	509	364	33.042	31.750	30.408	574691
600 x 710	23.622		27.953		7.874	7.480	8.661	516344	521583	10153	8703	36	M20 x 150	509	375	34.001	32.671	31.290	594460
620 x 730	24.409		28.740		7.874	7.480	8.661	531097	521583	10153	8703	36	M20 x 150	509	386	34.958	33.591	32.171	614302
640 x 750	25.197		29.528		7.874	7.480	8.661	549538	521583	10153	8703	36	M20 x 150	509	397	35.917	34.512	33.053	634145

Ordering example: RfN 7015.1

* B ≥ L+2x (L1-L) necessary

More sizes on request

Series	d	D
RfN 7015.1	140	190

■ Mounting of Locking Assembly

The values for T, F_{ax}, p_w and p_N apply to Locking Assemblies installed in oiled condition.

■ Surface finishes

For shafts and hub bores

R_a ≤ 125 RMS

■ Tolerances

We recommend the following mounting tolerances

shaft: h8 · hub: H8 - see table above

■ Location of several Locking Assemblies RfN 7015.1

Max. two RfN 7015.1 Locking Assemblies can be used in series, the transmissible torques and axial forces are added.

■ Change of screw tightening torques

A reduction of the contact pressures and the transmission values by reducing the tightening torque of the screws is possible. The admissible lower limit is a 50% reduction of tightening torque. There is an approximate linear relationship between T, T_A, F_{ax}, p_w and p_N.

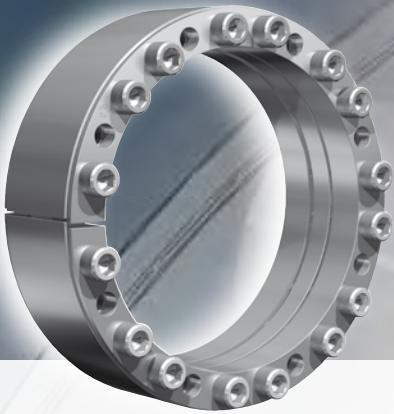

Characteristics

Precision Locking Assembly for transmission of torques, axial forces and special optimised for the transmission of bending moments, with special requirements to the true running of the clamped pieces.

Special Features

Through the long and flat cones one Locking Assembly RfN 7515 can transmit torques and axial forces and bending loads. At mounting is a small axial movement from Locking Assembly and hub.

⚠ Bending moment and radial loads – combined loads can be transmitted (Please contact our specialists for assistance).

Excellent centering ability – with a relatively wide design.

Example applications:

Belt drums, gear wheels

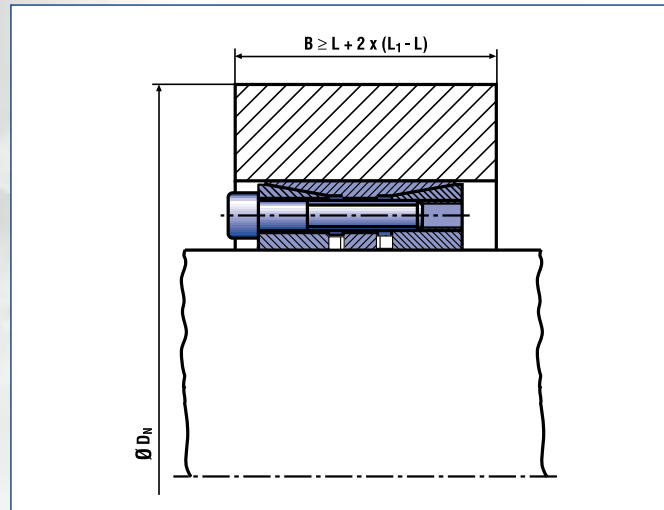

Locking Assembly RfN 7515 · Location

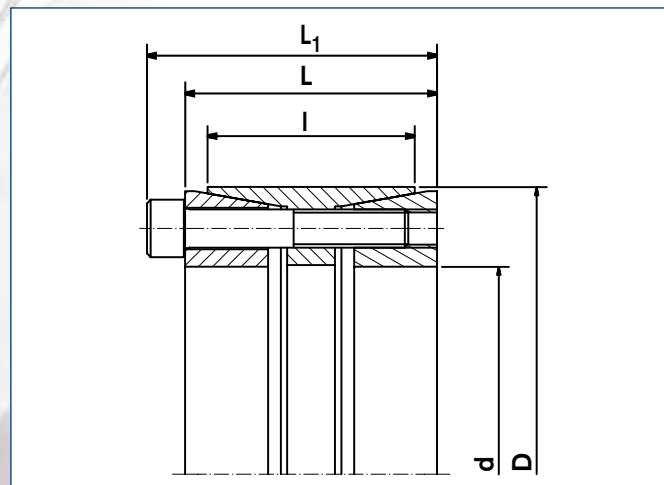

Locking Assembly RfN 7515 · Dimensions



Ready-for-shipping conveyor pulleys with Locking Assemblies

Locking Assembly dimensions						Surface pressure		Locking screws			Weight		min. D _N * R _{p0,2} [N/mm ²]		
d x D	L	I	L ₁	T	F _{ax}	P _W	P _N	n	d _G	T _A	≈	200	300	400	
mm	Inch			lb-ft	lbs	psi				lb-ft	lbs	Inch			
100 x 145	2,756	2,362	3,228	14089	85881	30604	21177	10	M12 x 60	107	9,48	11,417	8,661	7,874	
110 x 155	2,756	2,362	3,228	14753	85881	27849	19726	10	M12 x 60	107	9,92	11,417	9,055	8,268	
120 x 165	2,756	2,362	3,228	18588	94424	28139	20451	11	M12 x 60	107	11,03	12,598	9,843	9,055	
130 x 180	3,110	2,559	3,583	25596	120279	30459	22047	14	M12 x 70	107	14,55	14,567	11,024	9,843	
140 x 190	3,110	2,559	3,583	29579	128822	30314	22337	15	M12 x 70	107	15,44	15,748	11,811	10,630	
150 x 200	3,110	2,559	3,583	31645	128822	28284	21177	15	M12 x 70	107	16,54	15,354	11,811	10,630	
160 x 210	3,110	2,559	3,583	36070	137365	28284	21612	16	M12 x 70	107	17,42	16,535	12,598	11,417	
170 x 225	3,622	3,071	4,173	49053	176034	28574	21612	15	M14 x 80	170	24,03	18,504	13,780	12,205	
180 x 235	3,622	3,071	4,173	51929	176034	26978	20596	15	M14 x 80	170	25,14	18,110	13,780	12,598	
190 x 250	4,016	3,465	4,567	58494	187725	24223	18421	16	M14 x 80	170	32,19	17,717	14,173	12,992	
200 x 260	4,016	3,465	4,567	69264	211106	25818	19871	18	M14 x 80	170	32,63	19,685	15,354	14,173	
220 x 285	4,331	3,780	4,882	86746	240333	25238	19436	15	M16 x 90	262	43,88	21,654	16,929	15,354	
240 x 305	4,331	3,780	4,882	126136	320594	30895	24368	20	M16 x 90	262	47,41	38,583	21,260	18,110	
260 x 325	4,331	3,780	4,882	143470	336556	26978	21612	20	M16 x 90	262	50,49	29,134	20,472	18,110	
280 x 355	4,331	3,780	5,118	171574	373651	30024	23642	15	M20 x 90	509	72,99	35,039	22,835	20,079	
300 x 375	4,331	3,780	5,118	196137	398606	29879	23932	16	M20 x 90	509	67,47	38,189	24,409	21,654	
320 x 405	5,354	4,882	6,142	261492	498201	27704	21902	20	M20 x 110	509	102,09	39,370	25,984	23,228	
340 x 425	5,354	4,882	6,142	277867	498201	26108	20886	20	M20 x 110	509	107,82	37,402	26,378	23,622	
360 x 455	6,102	5,512	6,969	363359	615333	25383	20161	20	M22 x 130	686	145,97	37,402	27,559	24,803	
380 x 475	6,102	5,512	6,969	383570	615333	24077	19291	20	M22 x 130	686	153,25	36,614	27,953	25,591	
400 x 495	6,102	5,512	6,969	444056	676933	25238	20306	22	M22 x 130	686	161,85	41,339	30,315	27,165	
420 x 515	6,102	5,512	6,969	508230	738309	26108	21322	24	M22 x 130	686	168,68	46,850	32,283	28,740	
440 x 535	6,102	5,512	6,969	532572	738309	24948	20596	24	M22 x 130	686	176,4	45,669	32,677	29,528	
460 x 555	6,102	5,512	6,969	556914	738309	23932	19871	24	M22 x 130	686	183,02	44,488	33,465	29,921	
480 x 575	6,102	5,512	6,969	605598	769110	23787	19871	25	M22 x 130	686	189,63	46,063	34,646	31,102	
500 x 595	6,102	5,512	6,969	630678	769110	22917	19291	25	M22 x 130	686	198,45	46,063	35,039	31,890	
520 x 615	6,102	5,512	6,969	734684	861511	24658	20886	28	M22 x 130	686	205,07	53,543	38,189	33,858	
540 x 635	6,102	5,512	6,969	762714	861511	23787	20161	28	M22 x 130	686	211,68	51,969	38,583	34,646	
560 x 655	6,102	5,512	6,969	847542	922887	24513	21032	30	M22 x 130	686	222,71	57,874	40,945	36,220	
580 x 675	6,102	5,512	6,969	877786	922887	23642	20306	30	M22 x 130	686	229,32	55,906	40,945	37,008	
600 x 695	6,102	5,512	6,969	908029	922887	22917	19726	30	M22 x 130	686	238,14	55,118	41,339	37,402	
620 x 715	6,102	5,512	6,969	938272	922887	22192	19146	30	M22 x 130	686	246,96	54,724	42,126	38,189	
640 x 735	6,102	5,512	6,969	968515	922887	21467	18711	30	M22 x 130	686	255,78	54,724	42,520	38,976	

Ordering example: RfN 7515

* B ≥ L+2x (L1-L) necessary

More sizes on request

Series	d	D
RfN 7515	180	235

■ Mounting of Locking Assembly

The values for T, F_{ax}, P_W and P_N apply to Locking Assemblies installed in oiled condition.

■ Surface finishes

For shafts and hub bores
R_a ≤ 1,6 μm

■ Tolerances

We recommend the following mounting tolerances
shaft: h8 · hub: H8

■ Change of screw tightening torques

A reduction of the contact pressures and the transmission values by reducing the tightening torque of the screws is possible. The admissible lower limit results from the multiplication of the T_A values of the above table by 0,5. There is an approximate linear relationship between T, T_A, F_{ax}, P_W and P_N.

RINGFEDER® Locking Assemblies for Bending Moments



RINGFEDER® Locking Assemblies for Bending Moments



RfN 7012



RfN 7012.2



RfN 7015.0



RfN 7015.1

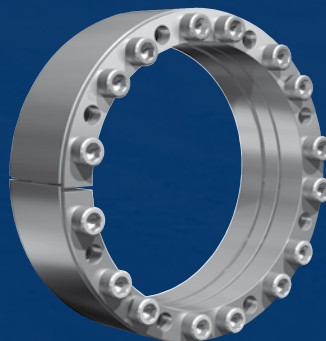

RfN 7515

Characteristics

One of the most demanding challenges in our promise of performance is the conveyor pulley application field. The extreme loads which such components are subject to, especially the high bending moment, coupled with the simultaneous indispensable reliability and longest possible service life, require the highest in engineering know-how. Our international development team, which has already set benchmarks in quality Locking Assemblies for the RfN 7012, RfN 7012.2, RfN 7015.0 and RfN 7015.1 products, is now reaching a further milestone.

The new development of the RfN 7515 Locking Assemblies has set a new benchmark in this segment with its quality, performance and price range.

Quality means: high-quality materials and material services, and the most precise workmanship, guarantee sustainable product usage.

Performance means: reliability, and long service life means: minimization of machine downtime and maximization of service life.

Price means: not just the newest, but also the most economical RINGFEDER Locking Assemblies product at the high level of performance you are used to.

RINGFEDER® Locking Assemblies for Bending Moments

Explanations to tables

d, D, L, l, L₁ = Basic dimensions,
Locking Assemblies not tightened

d	= Locking Assembly internal diameter
D	= Locking Assembly external diameter
L	= length Locking Assembly
l	= clamping length Locking Assembly
L ₁	= overall length Locking Assembly
T _{A red}	= maximum bolt tightening torque under bending moment load
T without M _b	= transmissible torque without bending moment
p _W without M _b	= shaft pressure without bending moment
p _N without M _b	= hub pressure without bending moment
M _b max.	= maximum transmissible bending moment at indicated bolt tightening torque
T _{res.}	= remaining transmissible torque at indicated M _b and T _a
p _W at M _b max.	= shaft pressure at indicated M _b max. and T _a
p _N at M _b max.	= hub pressure at indicated M _b max. and T _a



Typical belt drum application

The bending moment acting on the hub/shaft connection is the main load to evaluate in a belt drum or similar application. Excessive bending moments can cause overstress in the webs between the screw holes in the locking assembly. In the case of additional loads (bending moments/ radial loads) screw tightening torques may have to be reduced. To limit the influence of the bending load on the locking assembly connection we use the two following criteria during the belt drum design process:

- a) **Shaft deflection from the bending moments can only have a maximum deflection $f_m < 1/2000 * L$ (bearing centre distance).**
- b) **The permissible bending load values as shown in the following tables.**

RINGFEDER® Locking Assemblies for Bending Moments

Locking Assembly dimensions						T _A red.	T without M _b	p _W without M _b	p _N without M _b	M _b max.	T _{res.}	p _W at M _b max.	p _N at M _b max.
d	x	D	L	l	L ₁								
mm			inch			lb-ft		psi		lb-ft		psi	
100	x	145	1.299	1.024	1.850	92	7081	1119	771	1918	6786	1399	965
110	x	155	1.299	1.024	1.850	92	7745	1011	720	1992	7450	1273	902
120	x	165	1.299	1.024	1.850	92	9589	1051	765	2213	9368	1319	959
130	x	180	1.496	1.339	2.047	92	12909	925	668	3688	12392	1233	879
140	x	190	1.496	1.339	2.047	92	15269	937	691	3909	14753	1245	919
150	x	200	1.496	1.339	2.047	92	17703	954	714	4352	17187	1273	954
160	x	210	1.496	1.339	2.047	92	20432	965	737	4573	19916	1279	971
170	x	225	1.732	1.496	2.362	140	23899	897	680	5754	23235	1176	885
180	x	235	1.732	1.496	2.362	140	27514	919	702	6344	26850	1211	925
190	x	250	2.047	1.811	2.677	140	33857	839	634	8852	32677	1108	845
200	x	260	2.047	1.811	2.677	140	38062	851	651	9368	36882	1125	862
220	x	285	2.205	1.969	2.913	218	48979	834	640	12171	47430	1108	857
240	x	305	2.205	1.969	2.913	218	61297	874	685	11507	60191	1114	879
260	x	325	2.205	1.969	2.913	218	74870	908	725	9884	74206	1102	845
280	x	355	2.598	2.362	3.406	299	91614	799	634	21318	89106	1062	811
300	x	375	2.598	2.362	3.406	299	109981	834	668	14900	108949	1016	817
320	x	405	3.071	2.835	3.957	428	152764	851	674	22867	151068	1034	857
340	x	425	3.071	2.835	3.957	428	161690	799	640	35554	157780	1068	817
360	x	455	3.543	3.307	4.567	575	208308	788	622	46028	203145	1034	811
380	x	475	3.543	3.307	4.567	575	219151	742	594	53405	212586	1016	782
400	x	495	3.543	3.307	4.567	575	229921	702	565	54142	223503	965	805
420	x	515	3.543	3.307	4.567	575	267466	742	605	53921	261934	988	777
440	x	545	4.016	3.780	5.118	738	326625	720	582	69780	319101	959	771
460	x	565	4.016	3.780	5.118	738	340566	691	560	78189	331493	942	777
480	x	585	4.016	3.780	5.118	738	372137	691	565	81877	362990	948	771
500	x	605	4.016	3.780	5.118	738	405035	691	571	79665	389766	931	771
520	x	630	4.016	3.780	5.118	738	429820	680	560	88516	420599	937	748
540	x	650	4.016	3.780	5.118	738	445236	651	542	88516	436385	902	765
560	x	670	4.016	3.780	5.118	738	491412	668	565	91467	482856	914	771
580	x	690	4.016	3.780	5.118	738	529032	674	565	94417	520549	919	771
600	x	710	4.016	3.780	5.118	738	546071	651	548	98105	537219	897	754
620	x	730	4.016	3.780	5.118	738	585682	651	554	101056	576830	897	759
640	x	750	4.016	3.780	5.118	738	626547	657	560	100318	618507	891	759

Ordering example: RfN 7012

Series	d	D
RfN 7012	160	210

Remark! The values of the shaft- and hub pressures have been calculated with the screw tightening shown in the tables. Increase resp. reduction of the screw tightening torque results in different calculation values!

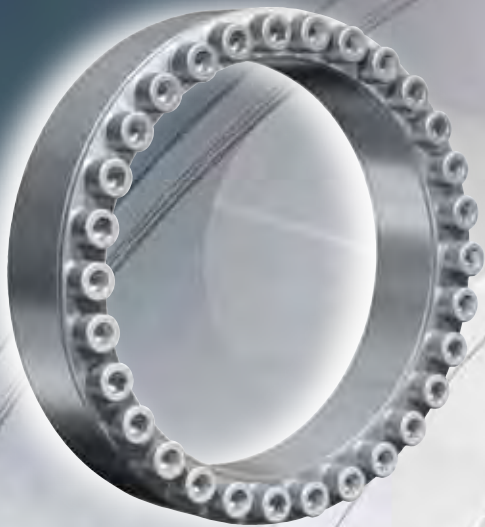

RfN 7012.2

NEW: The new Locking Assembly series RINGFEDER® RfN 7012.2 is specially designed to fulfil the requirements of constantly increasing bending moments for conveyor pulleys.

The challenge was to develop a product with the same dimensions as the standard RINGFEDER® RfN 7012 to fit into existing end discs – ⚠ yield point of end disc has to be checked – so that also material handling equipment at hand can be upgraded. At the same time the Locking Assembly should carry a multiple of the bending moments of the standard RINGFEDER® RfN 7012.

To comply with these requirements, we have collected the experiences of our customers and our knowledges of supplying to the market of heavy industry for more than 80 years. The result is the brand new RINGFEDER® RfN 7012.2, according to the table on page33.

A special bolt for type **RfN 7012.2** has been developed by RINGFEDER for the increased requirements occurring when subject to loading by bending moment.

These special bolts guarantee loadings above strength class 12.9 at simultaneous higher expansion with regard to tensile strength and yield strength.

These bolts were manufactured specially for RINGFEDER with qualified steel analysis.

Every bolt is labelled with RPT-B and the batch number. This allows every bolt to be traced back to manufacture

The benefit of this bolt is the considerably increased fracture resistance under additional bending stress.



RINGFEDER® Locking Assemblies for Bending Moments

Locking Assembly dimensions						T _A red.	T without M _b	P _W without M _b	P _N without M _b	M _b max.	T _{res.}	p _W at M _b max.	p _N at M _b max.
d	x	D	L	l	L ₁								
mm			inch			lb-ft		psi		lb-ft		psi	
100	x	145	1.299	1.024	1.850	92	7671	30750	21177	7376	2139	58018	40032
110	x	155	1.299	1.024	1.850	92	8409	27849	19726	7598	3541	53377	37857
120	x	165	1.299	1.024	1.850	92	10474	29299	21322	8704	5901	56132	40758
130	x	180	1.496	1.339	2.047	92	14384	26108	18856	11212	8925	50186	36261
140	x	190	1.496	1.339	2.047	92	17039	26688	19581	11802	12245	50186	36986
150	x	200	1.496	1.339	2.047	92	19842	27123	20306	10769	16671	47285	35391
160	x	210	1.496	1.339	2.047	92	22940	27559	20886	9811	20654	44674	34086
170	x	225	1.732	1.496	2.362	140	26702	25383	19146	19105	18736	48880	36841
180	x	235	1.732	1.496	2.362	140	30907	26108	20016	21023	22645	50476	38727
190	x	250	2.047	1.811	2.677	140	38136	23932	18276	27292	26629	45254	34376
200	x	260	2.047	1.811	2.677	140	41529	23497	18131	29505	29210	45399	34956
220	x	285	2.205	1.969	2.913	218	55028	23787	18276	37177	40570	45399	34956
240	x	305	2.205	1.969	2.913	218	62109	22482	17695	38283	48905	42933	33795
260	x	325	2.205	1.969	2.913	218	77230	23787	19001	36070	68305	41628	33215
280	x	355	2.598	2.362	3.406	299	97073	21467	16970	60486	75903	41338	32635
300	x	375	2.598	2.362	3.406	299	107105	20741	16535	61224	87926	39452	31475
320	x	405	3.071	2.835	3.957	428	148781	21032	16680	92942	116177	40032	31620
340	x	425	3.071	2.835	3.957	428	162722	20451	16390	97368	130414	39162	31330
360	x	455	3.543	3.307	4.567	575	216422	20741	16390	131299	172016	38727	30604
380	x	475	3.543	3.307	4.567	575	234789	20161	16100	143101	186179	38727	30895
400	x	495	3.543	3.307	4.567	575	253820	19726	15955	149002	205505	38002	30750
420	x	515	3.543	3.307	4.567	575	289153	20306	16535	143839	250870	37132	30314
440	x	545	4.016	3.780	5.118	738	353180	19871	15955	185146	300734	35826	29009
460	x	565	4.016	3.780	5.118	738	378112	19436	15810	208013	315781	36696	29879
480	x	585	4.016	3.780	5.118	738	403855	19001	15665	217602	340271	36406	29879
500	x	605	4.016	3.780	5.118	738	441179	19146	15810	224241	379882	36261	30024
520	x	630	4.016	3.780	5.118	738	468841	18856	15520	232355	407174	35826	29589
540	x	650	4.016	3.780	5.118	738	497313	18566	15375	238994	436090	35391	29444
560	x	670	4.016	3.780	5.118	738	538473	18711	15665	250058	476881	35681	29879
580	x	690	4.016	3.780	5.118	738	581183	18711	15810	260385	519590	35971	30169
600	x	710	4.016	3.780	5.118	738	612753	18566	15665	269974	550054	35681	30169
620	x	730	4.016	3.780	5.118	738	645062	18276	15520	269237	586125	34811	29589
640	x	750	4.016	3.780	5.118	738	705179	18711	15955	268499	652069	34666	29589

Ordering example: RfN 7012.2

Series	d	D
RfN 7012.2	200	260

Remark! The values of the shaft- and hub pressures have been calculated with the screw tightening shown in the tables. Increase resp. reduction of the screw tightening torque results in different calculation values!

Explanation to tables RfN 7012, RfN 7012.2, RfN 7015.0, RfN 7015.1 and RfN 7515

A bending moment, created by radial forces, results in an additional load for the Locking Assembly, shaft and hub. This load creates an additional pressure, works in rotation and has to be superpositioned with the pressure resulting from the Locking Assembly.

For a viable connection, a minimum surface pressure at the contact areas between Locking Assembly, shaft and hub must be maintained, as soon as shaft and hub has to take up the maximal pressures.

Additionally, the listed torque values (T) have been reduced due to the additional bending moments.

To achieve lower stresses for the Locking Assemblies RfN 7012 and RfN 7015.0, the screw tightening torques (T_A) have also been reduced.

RINGFEDER® Locking Assemblies for Bending Moments

Locking Assembly dimensions						T _A red.	T without M _b	P _W without M _b	P _N without M _b	M _b max.	T _{res.}	p _W at M _b max.	p _N at M _b max.
d	x	D	L	l	L ₁								
mm			inch										
100	x	145	2.559	2.362	3.031	85	8335	22772	15665	8040	2213	31040	21322
110	x	155	2.559	2.362	3.031	85	9147	20596	14650	8040	4426	28139	20016
120	x	165	2.559	2.362	3.031	85	12023	22772	16535	9589	7229	30895	22482
130	x	180	2.913	2.677	3.386	85	16228	22627	16390	13277	9368	30750	22192
140	x	190	2.913	2.677	3.386	85	21023	25238	18566	14015	15638	33215	24513
150	x	200	2.913	2.677	3.386	85	22498	23642	17695	15859	15933	31910	23932
160	x	210	2.913	2.677	3.386	85	28030	25818	19726	14753	23826	33070	25238
170	x	225	3.189	2.953	3.740	136	35406	25963	19581	23604	26334	34956	26398
180	x	235	3.189	2.953	3.740	136	37472	24513	18711	23973	28768	33215	25383
190	x	250	3.701	3.465	4.252	136	43963	21612	16390	30612	31497	29299	22337
200	x	260	3.701	3.465	4.252	136	55470	24658	19001	18441	52372	29154	22482
220	x	285	4.094	3.858	4.724	210	62551	22047	16970	44996	43447	30169	23352
240	x	305	4.094	3.858	4.724	210	90950	26978	21177	33194	84680	32490	25673
260	x	325	4.094	3.858	4.724	210	102679	25818	20741	31349	97737	30750	24658
280	x	355	4.961	4.724	5.669	288	128422	23352	18421	88516	93016	32055	25238
300	x	375	4.961	4.724	5.669	288	143322	22772	18131	92942	109096	31330	25093
320	x	405	5.591	5.315	6.378	406	195990	23062	18131	114333	159182	30604	24223
340	x	425	5.591	5.315	6.378	406	208234	21612	17405	130561	162206	29879	23787
360	x	455	6.496	6.220	7.362	550	273736	21612	17115	184409	202333	29589	23352
380	x	475	6.496	6.220	7.362	550	289005	20451	16390	183671	223135	27994	22337
400	x	495	6.496	6.220	7.362	550	304201	19436	15665	184409	241944	26688	21467
420	x	515	6.496	6.220	7.362	550	383275	22192	18131	221290	312978	30459	24803
440	x	545	7.087	6.772	8.031	708	471865	22337	17986	272925	384898	30459	24658
460	x	565	7.087	6.772	8.031	708	493330	21322	17405	272925	410936	29009	23642
480	x	585	7.087	6.772	8.031	708	549095	21757	17841	291366	477250	26398	21612
500	x	605	7.087	6.772	8.031	708	571962	20886	17260	291366	492150	28574	23642
520	x	630	7.874	7.480	8.937	1062	748257	22627	18711	390946	637980	30604	25238
540	x	650	7.874	7.480	8.937	1062	777025	21757	18131	390946	671469	29444	24368
560	x	670	7.874	7.480	8.937	1062	805792	21032	17550	390946	704589	28284	23642
580	x	690	7.874	7.480	8.937	1062	834560	20306	17115	392422	736528	27413	23062
600	x	710	7.874	7.480	8.937	1062	920863	20886	17695	417501	820840	28284	23787
620	x	730	7.874	7.480	8.937	1062	951623	20306	17260	422665	852558	27413	23207
640	x	750	7.874	7.480	8.937	1062	1074365	21467	18276	424878	986808	28429	24368

Ordering example: RfN 7015.0

Series	d	D
RfN 7015.0	240	305

Remark! The values of the shaft- and hub pressures have been calculated with the screw tightening shown in the tables. Increase resp. reduction of the screw tightening torque results in different calculation values!

Characteristics

Version of the Locking Assembly RfN 7015.0 with lower surface pressure for reduction the stresses at soft end discs.

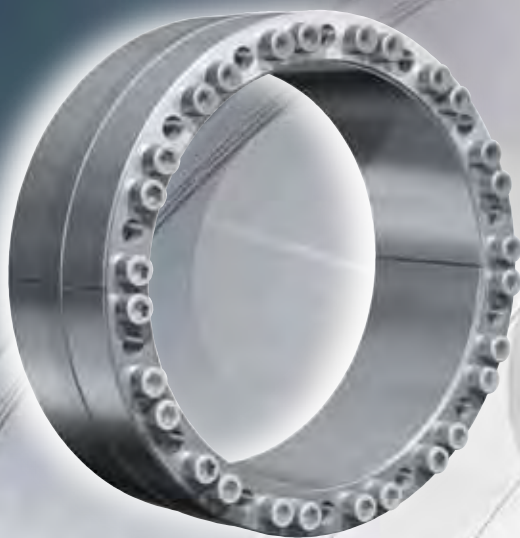

Conveyor Pulley with Locking Assemblies and a Shrink Disc® on the drive side

RINGFEDER® Locking Assemblies for Bending Moments

Locking Assembly dimensions						T _A	T without M _b	P _w without M _b	P _N without M _b	M _b max.	T _{res.}	P _w at M _b max.	P _N at M _b max.
d	x	D	L	l	L ₁								
mm	Inch			lb-ft	lb-ft								
100	x	145	2.559	2.362	2.953	61	4868	13199	9138	4500	1844	17841	12329
110	x	155	2.559	2.362	2.953	61	5901	13344	9428	5016	3172	17986	12764
120	x	165	2.559	2.362	2.953	61	7745	14650	10733	5975	4942	19871	14359
130	x	180	2.913	2.677	3.307	61	10474	14650	10588	8114	6712	19581	14214
140	x	190	2.913	2.677	3.307	61	11286	13634	10008	8114	7893	18131	13344
150	x	200	2.913	2.677	3.307	61	12909	13634	10153	8630	9663	18131	13634
160	x	210	2.913	2.677	3.307	61	15490	14359	10878	9737	12097	19146	14504
170	x	225	3.189	2.953	3.661	107	20211	15230	11604	12835	15564	20306	15375
180	x	235	3.189	2.953	3.661	107	22793	15375	11749	13425	18441	20306	15520
190	x	250	3.701	3.465	4.173	107	27071	13924	10588	18072	20137	18566	14069
200	x	260	3.701	3.465	4.173	107	31645	14650	11314	19916	24637	19581	15085
220	x	285	4.094	3.858	4.567	107	36587	12909	10008	25522	26186	17550	13489
240	x	305	4.094	3.858	4.567	107	45586	13489	10588	28768	35333	18276	14359
260	x	325	4.094	3.858	4.567	107	55544	14069	11168	32972	44701	19146	15230
280	x	355	4.961	4.724	5.512	170	84828	15375	12184	54585	64986	20886	16390
300	x	375	4.961	4.724	5.512	170	90950	14359	11604	54659	72657	19436	15520
320	x	405	5.591	5.315	6.220	262	132774	15955	12619	83353	103343	21467	16970
340	x	425	5.591	5.315	6.220	262	141036	14940	12039	81877	114850	20161	16100
360	x	455	6.496	6.220	7.205	358	154608	12184	9718	97368	120087	16390	13054
380	x	475	6.496	6.220	7.205	358	183597	13054	10443	109908	147084	17550	14069
400	x	495	6.496	6.220	7.205	358	229109	14650	11894	130561	188244	19726	15955
420	x	515	6.496	6.220	7.205	358	240543	13924	11314	130561	202038	18856	15375
440	x	545	7.087	6.772	7.874	509	274990	13199	10733	151953	229183	17695	14359
460	x	565	7.087	6.772	7.874	509	287456	12619	10298	155641	241723	17115	13924
480	x	585	7.087	6.772	7.874	509	333263	13489	11023	172607	285096	18131	14940
500	x	605	7.087	6.772	7.874	509	347205	12909	10733	174082	300365	17405	14359
520	x	630	7.874	7.480	8.661	509	385119	11604	9573	200637	328764	15665	12909
540	x	650	7.874	7.480	8.661	509	399946	11168	9283	202112	345139	15085	12619
560	x	670	7.874	7.480	8.661	509	466628	12184	10153	227929	407174	16390	13779
580	x	690	7.874	7.480	8.661	509	483298	11749	9863	224241	428123	15810	13344
600	x	710	7.874	7.480	8.661	509	499969	11314	9573	224979	446490	15230	12909
620	x	730	7.874	7.480	8.661	509	516639	11023	9283	226454	464341	14795	12619
640	x	750	7.874	7.480	8.661	509	533310	10588	9138	226454	482782	14359	12329

Ordering example: RfN 7015.1

Series	d	D
RfN 7015.1	620	730

Remark! The values of the shaft- and hub pressures have been calculated with the screw tightening shown in the tables. Increase resp. reduction of the screw tightening torque results in different calculation values!

Characteristics

Especially for the bending moment transmission designed 3 part Locking Assembly with reduced stresses in the Locking Assembly itself.

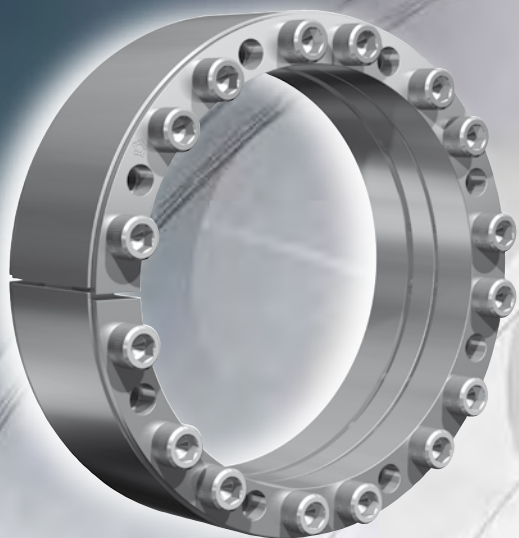

Ready-for-shipping conveyor pulleys with Locking Assemblies

RINGFEDER® Locking Assemblies for Bending Moments

Locking Assembly dimensions						T _A	T without M _b	P _W without M _b	P _N without M _b	M _b max.	T _{res.}	P _W at M _b max.	P _N at M _b max.
d	x	D	L	I	L ₁								
mm			Inch			lb-ft		psi		lb-ft	psi		
100	x	145	2.756	2.362	3.228	107	14089	30604	21177	5975	12761	35971	24803
110	x	155	2.756	2.362	3.228	107	14753	27849	19726	6639	13941	33215	23642
120	x	165	2.756	2.362	3.228	107	18588	28139	20451	8114	16744	34086	24803
130	x	180	3.110	2.559	3.583	107	25596	30459	22047	9220	23899	35536	25673
140	x	190	3.110	2.559	3.583	107	29579	30314	22337	12097	26997	36406	26833
150	x	200	3.110	2.559	3.583	107	31645	28284	21177	13277	28768	34521	25963
160	x	210	3.110	2.559	3.583	107	36070	28284	21612	14015	33194	34521	26253
170	x	225	3.622	3.071	4.173	170	49053	28574	21612	18441	45438	34231	25818
180	x	235	3.622	3.071	4.173	170	51929	26978	20596	20359	47799	32925	25238
190	x	250	4.016	3.465	4.567	170	58494	24223	18421	24711	52962	29589	22482
200	x	260	4.016	3.465	4.567	170	69264	25818	19871	29137	62846	31910	24513
220	x	285	4.331	3.780	4.882	262	86746	25238	19436	38357	77747	31765	24513
240	x	305	4.331	3.780	4.882	262	126136	30895	24368	31718	122079	35826	28139
260	x	325	4.331	3.780	4.882	262	143470	26978	21612	56945	131742	34521	27559
280	x	355	4.331	3.780	5.118	509	171574	30024	23642	77452	153133	39887	31475
300	x	375	4.331	3.780	5.118	509	196137	29879	23932	80771	178729	39452	31620
320	x	405	5.354	4.882	6.142	509	261492	27704	21902	104449	239731	35391	27994
340	x	425	5.354	4.882	6.142	509	277867	26108	20886	113596	253399	33941	27123
360	x	455	6.102	5.512	6.969	686	363359	25383	20161	161542	325445	33360	26398
380	x	475	6.102	5.512	6.969	686	383570	24077	19291	168181	344697	31910	25528
400	x	495	6.102	5.512	6.969	686	444056	25238	20306	177622	407027	32925	26688
420	x	515	6.102	5.512	6.969	686	508230	26108	21322	204767	465669	34666	28284
440	x	535	6.102	5.512	6.969	686	532572	24948	20596	225716	482782	33941	27994
460	x	555	6.102	5.512	6.969	686	556914	23932	19871	236043	504690	32925	27268
480	x	575	6.102	5.512	6.969	686	605598	23787	19871	251533	550866	33070	27559
500	x	595	6.102	5.512	6.969	686	630678	22917	19291	259647	574913	32055	26833
520	x	615	6.102	5.512	6.969	686	734684	24658	20886	308331	666969	35101	29589
540	x	635	6.102	5.512	6.969	686	762714	23787	20161	318658	693377	34086	29009
560	x	655	6.102	5.512	6.969	686	847542	24513	21032	347426	773410	35391	30314
580	x	675	6.102	5.512	6.969	686	877786	23642	20306	353770	803727	34376	29589
600	x	695	6.102	5.512	6.969	686	908029	22917	19726	372506	828512	33795	29154
620	x	715	6.102	5.512	6.969	686	938272	22192	19146	379882	858386	32925	28574
640	x	735	6.102	5.512	6.969	686	968515	21467	18711	385045	889219	32055	27849

Ordering example: RfN 7515

Series	d	D
RfN 7515	300	375

Remark! The values of the shaft- and hub pressures have been calculated with the screw tightening shown in the tables. Increase resp. reduction of the screw tightening torque results in different calculation values!

RINGFEDER® Locking Elements





RfN 8006
unslit



RfN 8006
slit

Characteristics

Customized application – By varying the number of Locking Elements, size, quantity and number of clamping screws, the connection can be adapted to fit most applications concerning surface pressures, materials, hub/shaft dimensions and available mounting space.

Transmission of high loads – up to 4 Locking Elements can be used in series, the transmissible torques and axial forces are not multiplied but increase according to a geometric progression (see page 50).

Maximum reliability – No matter whether the connection is subjected to static, pulsating, dynamic or intermittent loads.

Simple manufacture – Shaft and hub are designed without keyway. Apart from this, relatively large tolerances are admissible.

Easy adjustability – Locking Element connections can be adjusted at any time to any position by following the simple removal and assembly instructions.

Backlash-free – The Locking Element connection is a mechanical shrink fit and will not wear or loosen in service provided the maximum transmissible values for the connection are not exceeded.

High fatigue strength under alternating torsional stresses – As neither the shaft nor hub features grooves, the notch effect is minimized, thus giving a higher polar section modulus and allowing smaller diameters to be designed in.

Easy mounting – Hubs can be located at any point on the shaft and adjusted to precise angles. Only a few standard screws are then tightened to a specific torque value, no skilled assembly work is required.

Easy removal – Locking Elements are self releasing. No additional measures or auxiliary equipment is required.

Wear and maintenance-free – Unlimited lifetime if designed and used correctly.

Explanations to tables

d, D, L, l = Basic dimensions, Locking Elements not tightened

C_1 = shaft tolerances

C_b = hub bore tolerances

C_2 = bore tolerances

A_t = effective bearing surface $A_t = \pi \cdot d \cdot l$

X = travel distance for 1,2,3 or 4 Locking Elements. This value includes a safety allowance to ensure that the thrust flange will not contact the face of the hub or shaft. Any reduction of this value could cause a block and the transmission values of the connection would not be achieved.

T = transmissible torque

F_{ax} = axial forces

T and F_{ax} refer to a pressure between the Locking Element and shaft of 14500 psi .

When unslit Locking Elements the required total clamping force F_A is obtained by:

$$F_A = F_{A'} + F_O$$

$F_{A'}$ = Screw number x Fv, see screw table page 40

F_O = approximate clamping force required to bridge the clearances where the tolerances given in the table are fully exploited during manufacture, not applicable if slit Locking Elements are used.

d_1 = clamp plate bore

D_1 = spacer sleeve OD

T_{max} = transmissible torque by one Locking Element at a shaft contact pressure of = 47850 psi



Unslit

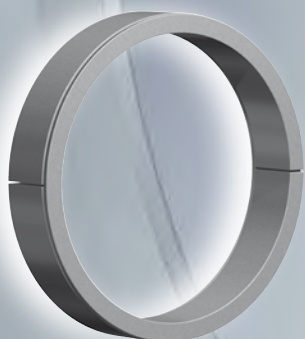

Slit

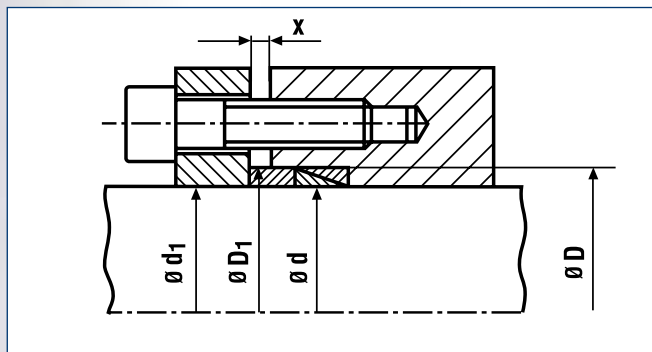

RINGFEDER® Locking Element RfN 8006 · Typical installation

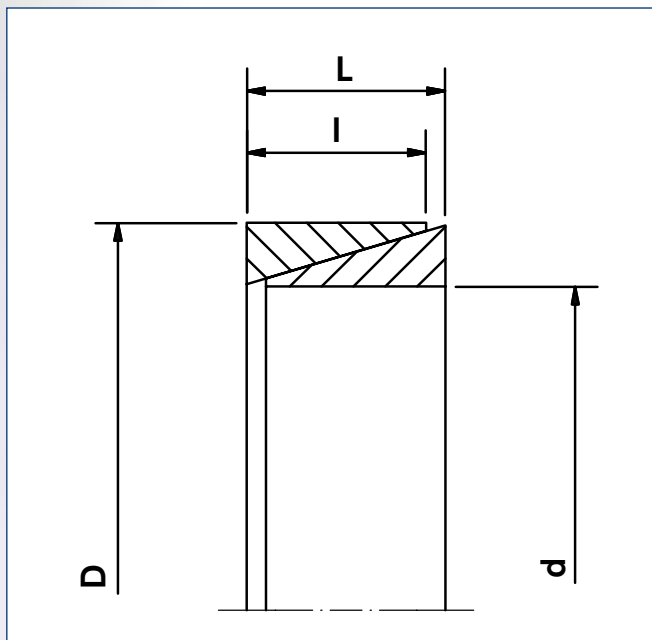

RINGFEDER® Locking Elements RfN 8006 · Dimensions

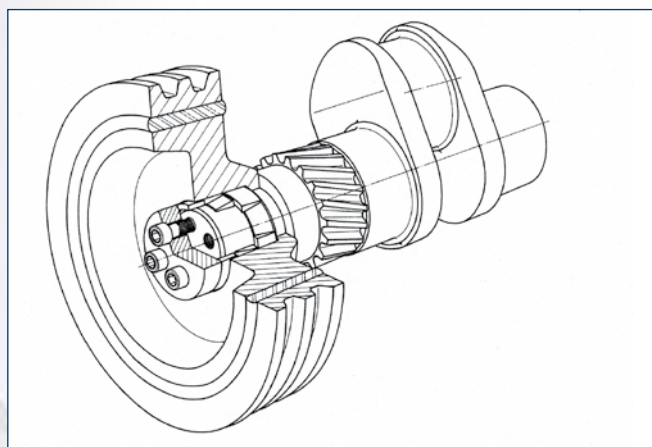

V-belt pulley

Locking screw calculation Locking screw table

The torque transmission capacity of a RINGFEDER® Locking Element connection is directly proportional to the effective clamping force F_A . Clamp force is normally achieved via clamping screws and a thrust plate.

Regular thread ¹⁾ , metric						
d_G	8.8		10.9		12.9	
	T_A	F_V	T_A	F_V	T_A	F_V
M 4	2.9	3 900	4.1	5 450	4.9	6 550
M 5	6.0	6 350	8.5	8 950	10	10 700
M 6	10	9 000	14	12 600	17	15 100
M 8	25	16 500	35	23 200	41	27 900
M10	49	26 200	69	36 900	83	44 300
M12	86	38 300	120	54 000	145	64 500
M14	135	52 500	190	74 000	230	88 500
M16	210	73 000	295	102 000	355	123 000
M18	290	88 000	405	124 000	485	148 000
M20	410	114 000	580	160 000	690	192 000
M22	550	141 000	780	199 000	930	239 000
M24	710	164 000	1000	230 000	1200	276 000
M27	1050	215 000	1500	302 000	1800	363 000
M30	1450	262 000	2000	368 000	2400	442 000

1 Nm = 0.738 lb-ft
1 N = 0.225 lb

Regular thread , Inch							
BOLT SIZE	BOLT DIA.	F_V	T_A	BOLT SIZE	BOLT DIA.	F_V	T_A
Inch	Inch	lbs	lb-in	Inch	Inch	lbs	lb-ft
4-40	0.112	540	12	1/4"-20	0.25	2850	12
4-48	0.112	600	13	1/4"-28	0.25	3250	14
6-32	0.138	820	23	5/16"-18	0.3125	4700	25
6-40	0.138	920	25	5/16"-24	0.3125	5200	25
8-32	0.164	1260	41	3/8"-16	0.375	6950	45
8-36	0.164	1320	43	3/8"-24	0.375	7900	50
10-24	0.19	1580	60	7/16"-14	0.4375	9600	70
10-32	0.19	1800	68	7/16"-20	0.4375	10700	80
				1/2"-13	0.5	12800	110
				1/2"-20	0.5	14400	120
				9/16"-12	0.5625	16400	150
				9/16"-18	0.5625	18300	170

Unslit

Slit

1) T_A = tightening torque (Nm)
 F_V = initial clamping force (N)
(screws oiled, $\mu_{total} = 0.14$)

Locking Assembly dimensions										Clamping force		Transmissible torques or axial forces		Locking Elements				Weight	Diameter spacer sleeve		
d x D	d	C ₁	C _b	D	C ₂	L	I	At	F ₀	FA'	T	F _{ax}	1	2	3	4	WT	inside d ₁	outside D ₁	T _{max}	
mm	Inch									psi	lb-ft	lbs	Inch				lbs 10 ⁻³	Inch		lb-ft	
260 x 290	10.236			11.417		1.890	1.732	55.955	40917	438399	41676	97797	0.276	0.394	0.512	0.630	10584	10.268	11.386	87249	
270 x 300	10.630			11.811	-0.0032	1.890	1.732	58.125	39793	456385	44996	101169	0.276	0.394	0.512	0.630	10805	10.661	11.780	94157	
280 x 313	11.024	+0.0032	-0.0032	12.323		2.087	1.929	66.805	46313	523831	53479	116906	0.276	0.433	0.551	0.669	13892	11.055	12.291	111663	
290 x 323	11.417			12.717		2.087	1.929	69.130	49910	541817	57167	120279	0.276	0.433	0.551	0.669	14333	11.449	12.685	119337	
300 x 333	11.811			13.110		2.087	1.929	71.610	48112	559802	61224	124775	0.276	0.433	0.551	0.669	14774	11.843	13.079	127854	
320 x 360	12.598			14.173	+0.0035	2.559	2.323	91.915	65647	719424	84090	159622	0.394	0.591	0.787	0.984	24035	12.638	14.134	177231	
340 x 380	13.386			14.961		2.559	2.323	97.650	61151	764388	94786	169739	0.394	0.591	0.787	0.984	25358	13.425	14.921	200420	
360 x 400	14.173	+0.0035	-0.0035	15.748		2.559	2.323	103.385	58004	809353	106219	179856	0.394	0.591	0.787	0.984	26901	14.213	15.709	224858	
380 x 420	14.961	-0.0038	+0.0038	16.535		2.559	2.323	109.120	60477	854317	118390	189973	0.394	0.591	0.787	0.984	28224	15.000	16.496	249923	
400 x 440	15.748			17.323	-0.0038	2.559	2.323	115.010	57554	899281	131299	200090	0.394	0.591	0.787	0.984	29768	15.787	17.283	277097	
420 x 460	16.535	+0.0038	-0.0038	18.110		2.559	2.323	120.590	54856	944245	144576	210207	0.394	0.591	0.787	0.984	31091	16.575	18.071	305640	
440 x 480	17.323	-0.0038	+0.0038	18.898		2.559	2.323	126.325	52608	989209	158592	220324	0.394	0.591	0.787	0.984	32414	17.362	18.858	335509	

Ordering example:
RfN 8006 unslit

Ordering example:
RfN 8006 slit

More sizes on request

Series	d	D
RfN 8006	300	333

Series	d	D	Further details
RfN 8006	300	333	G (= slit)

■ Mounting of Locking Element

The values for T, F_{ax}, p_w and p_N apply to Locking Elements installed in oiled condition.

■ Surface finishes

For shafts and hub bores

R_a ≤ 63 RMS

Required screw tension force

for Locking Elements unslit: $F_A = F_{A'} + F_0$

for Locking Elements slit: $F_A = F_{A'}$

Where n-Locking Elements are used one behind the other (series), the following applies to the increase in T and F_{ax}:

$$T_n = T_1 \cdot m \quad \text{and} \quad F_{axn} = F_{ax1} \cdot m$$

Retaining the values for T and F_{ax} it is possible to reduce F_{A'} and p where:

$$F_{A'n} = F_{A'}/m \quad \text{and} \quad p_N = p/m$$

With 2 / 3 / 4 Locking Elements, m = 1.555 / 1.86 / 2.03

For tolerances see table on 39/41.

The fits specified have given excellent service in practical operations. Naturally, the shafts and the bores can feature other clearances. Please contact our Technical Department.

■ Undercut, clearance cut

The relatively narrow RINGFEDER® RfN 8006 Locking Elements mainly serve the purpose of transmitting large torques and axial forces. They are not self-centering. The concentricity accuracy of the clamped hub therefore depends on the centering and care with which installation is carried out. Locking Elements RfN 8006 can center themselves within the framework of their production accuracy if they are absolutely plane-parallel when pressed together.

1) approx. values

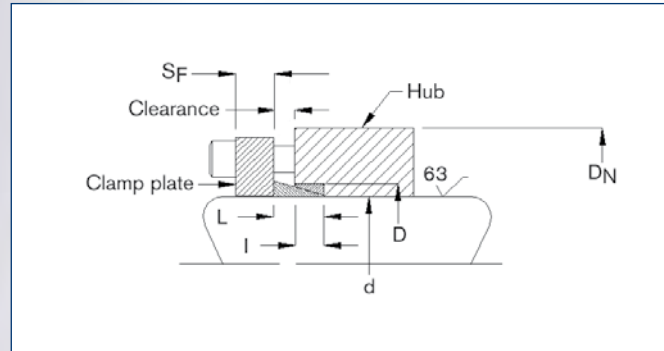

Hub bolted Clamp Plate (hub axially adjustable)

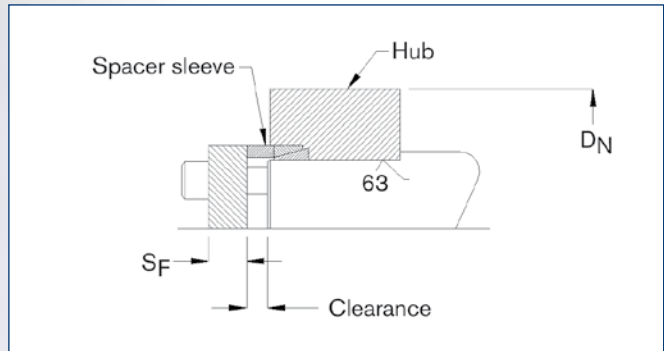

Shaft bolted Clamp Plate (hub axially fixed)

Explanations

- d = shaft diameter
- C_1 = machining tolerances for shaft (d)
- D = counter bore diameter
- C_2 = machining tolerances for counter bore (D)
- L, I = width dimensions, relaxed condition
- R = radius in hub bore
- F_O = preload to bridge specified fit clearances
- F_A = actual locking force to generate T
- T = transmissible torque for one Locking Element
based on coefficient of friction of $\mu = 0.15$ and
10,000 psi contact pressure
(torque can be increased by up to 50%)
- F_{ax} = axial load (thrust capacity)
- D_N = Hub outer diameter
- S_F = Clamp plate thickness

Size	GSA dimensions						F _o	F _A '	Transmissible torques or axial forces		Weight WT
	d	C ₁	D	C ₂	L	I			T	F _{ax}	
	Inch								psi	lb-in	
GSA-250	0.2500		0.3750		0.126	0.094	580	450	14	112	0.76
GSA-312	0.3125	+0	0.4375	-0	0.143	0.112	686	670	26	166	1.04
GSA-375	0.3750	-0.0005	0.5000	+0.0005	0.160	0.128	673	920	43	229	1.35
GSA-437	0.4375		0.5937		0.176	0.143	796	1196	65	297	2.20
GSA-500	0.5000		0.6562		0.193	0.158	944	1512	94	376	2.69
GSA-562	0.5625		0.7500	-0	0.210	0.174	1259	1872	132	469	3.97
GSA-625	0.6250		0.8125	+0.001	0.226	0.187	1231	2237	175	560	4.69
GSA-687	0.6875		0.8750		0.243	0.203	1414	2670	230	669	5.47
GSA-750	0.7500	+0	0.9375		0.260	0.219	1413	3145	295	787	6.33
GSA-812	0.8125	-0.001	1.0312		0.276	0.234	1617	3637	370	911	8.56
GSA-875	0.8750		1.0937	-0	0.293	0.250	1611	4188	458	1047	10.14
GSA-937	0.9375		1.1875	+0.0015	0.310	0.267	2087	4790	561	1197	12.36
GSA-1000	1.0000		1.2500		0.326	0.284	2090	5437	680	1360	14.05
GSA-1125	1.1250	+0	1.4060		0.359	0.312	2220	6620	840	1493	19.55
GSA-1250	1.2500	-0.0015	1.5310		0.393	0.344	2240	8105	1140	1824	23.54
GSA-1375	1.3750		1.6870		0.426	0.376	2745	9750	1510	2196	31.22
GSA-1500	1.5000		1.8120	-0	0.459	0.407	3030	11510	1940	2587	36.38
GSA-1625	1.6250	+0	1.9680	+0.002	0.492	0.437	3295	13390	2450	3015	46.43
GSA-1750	1.7500	-0.002	2.1250		0.526	0.469	3585	15475	3045	3480	58.53
GSA-1875	1.8750		2.2500		0.559	0.500	3595	17675	3730	3979	66.22
GSA-2000	2.0000		2.4060		0.592	0.528	5365	19910	4480	4480	81.09
GSA-2250	2.2500		2.6560		0.592	0.528	4795	22400	5670	5040	90.30
GSA-2437	2.4375		2.8430		0.592	0.528	4430	24260	6655	5461	97.07
GSA-2500	2.5000	+0	2.9060	-0	0.592	0.528	4330	24885	7000	5600	99.50
GSA-2687	2.6875	-0.003	3.0930	+0.003	0.592	0.528	4035	26750	8090	6020	106.26
GSA-2750	2.7500		3.1560		0.592	0.528	3950	27370	8470	6160	108.70
GSA-3000	3.0000		3.4060		0.592	0.528	3890	29860	10080	6720	117.90

Ordering example: GSA

Series	Size	d
GSA	GSA-812	0.8125

* Stainless steel available upon request.

* Delivery on request; other sizes stocked. Contact Ringfeder Corporation for additional sizes and information.

■ Selection Guide

1. Determine the shaft diameter to be used and the maximum torque (T) to be transmitted.

$$T = \frac{63,000 \text{ (lb-in)} \times \text{HP}}{\text{RPM}}$$

2. Select a locking element from the specification table for the shaft diameter. Verify that the transmissible torque (T) for the element meets the torque requirement.

Note: Required peak torque should never exceed specified transmissible torque (T). Higher torque capacities can be obtained by increasing the locking force.

3. Determine the required locking force (F_A'). A pre-load (F_O) is required to bridge the clearance for the specified fits. The total required locking force is F_A' = F_O + F_A'. The locking force is normally obtained by using one or more screws and a clamp plate.

4. Refer to screw tables on page 40 to determine the number, size and grade of screws needed for the required locking force and individual screw clamp load.

$$\text{Clamp load/screw} = \frac{\text{required locking force (F}_{A}'\text{) or F}_{A}'}{\text{number of screws (z)}}$$

STAINLESS



Locking Assemblies



RfN 7012
stainless

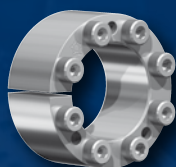

RfN 7061
stainless

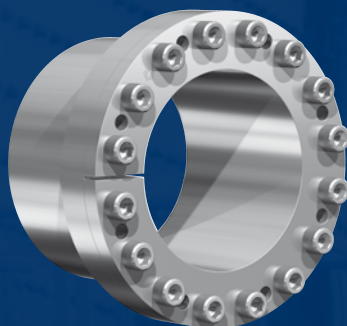

RfN 7110
stainless

Locking Elements



RfN 8006
unslit
stainless



RfN 8006
slit
stainless

Characteristics

Inexpensive manufacture – The large tolerances that are possible and the simple turning process guarantee inexpensive manufacture.

Simple installation – Only a few screws need to be tightened, alignment to precise angles between the hub and shaft is possible in any position, no difficult assembly work is required.

Simple dismantling – RINGFEDER® Locking Assemblies come with with threaded extraction holes, so that no additional auxiliary equipment is necessary, series RfN 7012 is self-releasing.

High reversing load fatigue strength – Shaft and hub are not keyed, so that there is no weakening of these components. Shaft and hub can be designed to be considerably smaller (lighter, cost and space-saving design possible).

No danger of deflection – RINGFEDER® Locking Assemblies are absolutely backlash-free.

Effect similar to overload protection – After the frictional connection force has been exceeded the Locking Assemblies simply slip. Valuable machine parts are protected. The Locking Assemblies are subject to the same laws as any other connection with force transmission by friction - not suitable as overload protection.

Completely maintenance-free – No follow-up costs.

Explanations to tables

$d, D, D_1, L, l, L_1, L_2$ = Basic dimensions,
Locking Assemblies not tightened

C_1 = shaft tolerances

C_b = hub bore tolerances

C_2 = bore tolerances

T = transmissible torque

F_{ax} = transmissible axial force

p_w = surface pressure between Locking Assembly
and shaft

p_N = surface pressure between Locking Assembly
and hub

n = quantity

d_G = clamping thread

T_A = maximum tightening torque for the screws
considered in order to determine the values
 T, F_{ax}, p_w and p_N

D_N = minimum required outside hub diameter

$R_{p0,2}$ = minimum required yield point of hub material

$d1$ = clamp plate bore

$D1$ = spacer sleeve OD

T_{max} = maximum theoretical transmissible torque

B = minimum hub width (calculation formula at
www.ringfeder.com)

STAINLESS

Characteristics

As the industry standard the RfN 7012-IN stainless Locking Assembly is suitable for most applications.

Transmission of high loads – Up to 4 RfN 7012-IN stainless Locking Assemblies can be used in series, the transmissible torques and axial forces are added. (Please contact our specialists for assistance).

Bending moment and radial loads – Combined loads can be transmitted, please contact our specialist for assistance.

Low risk to contamination – During tightening process the functional surfaces of the device are under pressure, sufficient enough to keep contaminants out, thereby preserving the integrity of the the device.

Adjustable transmission values – The locking screw torque can be changed giving a corresponding change in transmission values. RfN 7012-IN stainless Locking Assemblies can be tightened and released repeatedly.

Example applications:

Sprockets, gears, coupling hubs, conveyor pulleys, idler wheels, sheaves

STAINLESS

Size	Locking Assembly dimensions							Transmissible torques or axial forces		Surface Pressure		Locking screws DIN EN ISO 4762-A2-70				Weight		min. D _N *		
	d	C ₁	D	C ₂	L	I	L ₁	T	F _{ax}	Shaft p _W	Hub p _N	Thread			WT	d _D	Rp0,2[psi]			
	Inch	Inch						lb-ft	lbs	psi		n	d _G	s	T _A	lbs	mm	36000 45000 62000		
3/4	0.750	+0	1.850	-0	0.787	0.669	1.083	185	5920	28450	11500	8	M6x18	5	6	0.5	M8	2.404	2.278	2.149
1	1.000	-0.002	1.969	+0.002	0.787	0.669	1.083	275	6600	27000	13700	9	M6x18	5	6	0.6	M8	2.697	2.525	2.355
1 1/8	1.125		2.165		0.787	0.669	1.083	345	7360	23720	12300	10	M6x18	5	6	0.7	M8	2.868	2.705	2.542
1 3/16	1.1875		2.159		0.813	0.669	1.108	362	7316	24900	13700	10	M6x18	5	6	0.7	M8	2.956	2.768	2.581
1 1/4	1.250		2.362		0.787	0.669	1.083	459	8813	28000	14800	12	M6x18	5	6	0.7	M8	3.325	3.093	2.866
1 3/8	1.375		2.365		0.776	0.669	1.071	506	8832	25600	14900	12	M6x18	5	6	0.7	M8	3.335	3.101	2.873
1 7/16	1.4375		2.559		0.787	0.669	1.083	608	10151	28450	16000	15	M6x18	5	6	0.8	M8	3.710	3.427	3.155
1 1/2	1.500	+0	2.559	-0	0.787	0.669	1.083	636	10176	27000	15800	15	M6x18	5	6	0.8	M8	3.695	3.417	3.148
1 5/8	1.625	-0.0025	2.953	+0.0025	0.945	0.787	1.319	1070	15803	32700	18000	12	M8x22	6	10	1.3	M10	4.510	4.114	3.741
1 11/16	1.6875		2.953		0.945	0.787	1.319	1109	15772	28430	16200	12	M8x22	6	10	1.3	M10	4.310	3.975	3.653
1 3/4	1.750		2.953		0.945	0.787	1.319	1150	15771	30000	17800	12	M8x22	6	10	1.3	M10	4.484	4.096	3.730
1 7/8	1.875		3.150		0.945	0.787	1.319	1222	15642	28450	16900	12	M8x22	6	10	1.4	M10	4.679	4.298	3.933
1 15/16	1.9375		3.150		0.945	0.787	1.319	1259	15595	27000	16600	12	M8x22	6	10	1.4	M10	4.640	4.270	3.916
2	2.000		3.346		0.945	0.787	1.319	1519	18228	30600	18300	14	M8x22	6	10	1.4	M10	5.151	4.689	4.256
2 1/8	2.125		3.346		0.945	0.787	1.319	1613	18217	29150	18500	14	M8x22	6	10	1.4	M10	5.181	4.710	4.269
2 3/16	2.1875		3.543		0.945	0.787	1.319	1656	18169	28450	17600	14	M8x22	6	10	1.5	M10	5.350	4.894	4.462
2 1/4	2.250		3.543		0.945	0.787	1.319	1700	18133	27000	17100	14	M8x22	6	10	1.5	M10	5.292	4.854	4.437
2 3/8	2.375		3.531		0.996	0.787	1.370	1787	18058	25600	17200	14	M8x22	6	10	1.5	M10	5.284	4.844	4.426
2 7/16	2.4375		3.740		0.945	0.787	1.319	2098	20657	28450	18500	16	M8x22	6	10	1.6	M10	5.796	5.267	4.773
2 1/2	2.500	+0	3.740	-0	0.945	0.787	1.319	2148	20621	27750	18500	16	M8x22	6	10	1.6	M10	5.797	5.268	4.774
2 9/16	2.5625	-0.003	3.737	+0.003	0.959	0.787	1.333	2199	20596	27000	18500	16	M8x22	6	10	1.6	M10	5.787	5.260	4.768
2 5/8	2.625		4.331		1.102	0.945	1.555	3120	28526	30514	18500	14	M10x25	8	19	2.8	M12	6.703	6.094	5.524
2 11/16	2.6875		4.331		1.102	0.945	1.555	3195	28532	29804	18500	14	M10x25	8	19	2.8	M12	6.703	6.094	5.524
2 3/4	2.750		4.337		1.079	0.945	1.532	3320	28975	29850	18900	14	M10x25	8	19	2.8	M12	6.791	6.155	5.565
2 7/8	2.875		4.528		1.102	0.945	1.555	3450	28800	28450	18000	14	M10x25	8	19	2.9	M12	6.928	6.317	5.742
2 15/16	2.9375		4.528		1.102	0.945	1.555	3522	28775	27750	18000	14	M10x25	8	19	2.9	M12	6.917	6.309	5.737

Ordering example: RfN 7012-IN

* B ≥ 2 l necessary

More sizes on request

Series	Size	Further details
RfN 7012-IN	1 7/8	SS (=stainless steel)

■ Mounting of Locking Assembly

The values for T, F_{ax}, p_W and p_N apply to Locking Assemblies installed in oiled condition.

■ Surface finishes

For shafts and hub bores

R_a = 125 RMS

■ Tolerances

We recommend the following mounting tolerances

shaft: k9-h9 · hub: N9-H9 - see table above

shaft: k11-h11 · hub: N11-H11

To avoid excessive deformations of the relatively thickwalled thrust rings, the Locking Assembly should be located as symmetrically as possible between shaft and hub bore. If the shaft is smaller than nominal d, the bore should exceed nominal D to the same extent and vice versa. The true running out quality is determined by the direct centering between shaft and hub.

■ Location of several Locking Assemblies RfN 7012 stainless

If several Locking Assemblies are to be installed the transmission values of the table can be added when the Locking Assemblies are located within a distance of 4 x L₁.

■ Change of screw tightening torques

The Locking Assemblies are generally equipped with A2-70 grade screws. A reduction of the screw tightening torque is possible. (Please contact our specialists for assistance).

■ Auxiliary Threads

To facilitate removal, the front thrust rings have pullout threads.

Characteristics

As the industry standard the RfN 7012 stainless Locking Assembly is suitable for most applications.

Transmission of high loads – Up to 4 RfN 7012 stainless Locking Assemblies can be used in series, the transmissible torques and axial forces are added. (Please contact our specialists for assistance).

Bending moment and radial loads – Combined loads can be transmitted, please contact our specialist for assistance.

Low risk to contamination – During tightening process the functional surfaces of the device are under pressure, sufficient enough to keep contaminants out, thereby preserving the integrity of the the device.

Adjustable transmission values – The locking screw torque can be changed giving a corresponding change in transmission values. RfN 7012 stainless Locking Assemblies can be tightened and released repeatedly.

Example applications:

Sprockets, gears, coupling hubs, conveyor pulleys, idler wheels, sheaves

STAINLESS

Locking Assembly dimensions									Transmissible torques or axial forces		Surface Pressure		Locking screws DIN EN ISO 4762-A2-70			Weight	min. D _N *		
d x D	d	C ₁	D	C ₂	L	I	L ₁	T	F _{ax}	Shaft P _W	Hub P _N	n	Thread d _G	T _A	WT	R _{p0,2} [psi]			T _{max}
mm	Inch							lb-ft	lbs	psi			mm	lb-ft	lbs	Inch			lb-ft
19 x 47	0.748		1.850		0.787	0.669	1.083	105	11065	17986	7252	8	M 6 x 18	6	0.5	2.177	2.106	2.032	122
20 x 47	0.787	+0	1.850	-0	0.787	0.669	1.083	111	11065	16970	7252	8	M 6 x 18	6	0.5	2.177	2.106	2.032	129
22 x 47	0.866	-0.002	1.850	+0.002	0.787	0.669	1.083	121	11065	15375	7252	8	M 6 x 18	6	0.5	2.177	2.106	2.032	142
24 x 50	0.945		1.969		0.787	0.669	1.083	148	12540	15810	7542	9	M 6 x 18	6	0.6	2.332	2.253	2.171	175
25 x 50	0.984		1.969		0.787	0.669	1.083	154	12540	15085	7542	9	M 6 x 18	6	0.6	2.332	2.253	2.171	181
28 x 55	1.102		2.165		0.787	0.669	1.083	171	12540	13344	6817	9	M 6 x 18	6	0.7	2.522	2.445	2.365	204
30 x 55	1.181		2.165		0.787	0.669	1.083	182	11802	12474	6817	9	M 6 x 18	6	0.6	2.522	2.445	2.365	218
32 x 60	1.260		2.362		0.787	0.669	1.083	258	16228	15520	8268	12	M 6 x 18	6	0.7	2.844	2.739	2.629	311
35 x 60	1.378		2.362		0.787	0.669	1.083	281	16228	14069	8268	12	M 6 x 18	6	0.7	2.844	2.739	2.629	339
38 x 65	1.496	+0	2.559	-0	0.787	0.669	1.083	380	19916	16100	9428	15	M 6 x 18	6	0.8	3.165	3.031	2.892	460
40 x 65	1.575	-0.0025	2.559	+0.0025	0.787	0.669	1.083	398	19916	15230	9428	15	M 6 x 18	6	0.7	3.165	3.031	2.892	485
42 x 75	1.654		2.953		0.945	0.787	1.319	566	27292	16680	9428	12	M 8 x 22	13	1.3	3.653	3.497	3.337	690
45 x 75	1.772		2.953		0.945	0.787	1.319	603	25817	15520	9283	12	M 8 x 22	13	1.3	3.640	3.488	3.331	740
48 x 80	1.890		3.150		0.945	0.787	1.319	642	26555	14504	8703	12	M 8 x 22	13	1.4	3.832	3.682	3.526	789
50 x 80	1.969		3.150		0.945	0.787	1.319	666	26555	13924	8703	12	M 8 x 22	13	1.3	3.832	3.682	3.526	822
55 x 85	2.165		3.346		0.945	0.787	1.319	850	30981	14650	9428	14	M 8 x 22	13	1.4	4.139	3.963	3.781	1055
60 x 90	2.362		3.543		0.945	0.787	1.319	922	30981	13344	8848	14	M 8 x 22	13	1.5	4.324	4.152	3.973	1159
65 x 95	2.559	+0	3.740	-0	0.945	0.787	1.319	1136	34669	14069	9573	16	M 8 x 22	13	1.6	4.642	4.441	4.234	1425
70 x 110	2.756	-0.003	4.331	+0.003	1.102	0.945	1.555	1655	47209	14650	9283	14	M10 x 25	26	2.8	5.339	5.116	4.885	2086
75 x 115	2.953		4.528		1.102	0.945	1.555	1766	47209	13634	8848	14	M10 x 25	26	2.9	5.526	5.306	5.078	2235
80 x 120	3.150		4.724		1.102	0.945	1.555	1877	47209	12764	8558	14	M10 x 25	26	3.1	5.727	5.507	5.278	2384
85 x 125	3.346		4.921		1.102	0.945	1.555	2270	53110	13634	9283	16	M10 x 25	26	3.3	6.067	5.813	5.550	2895
90 x 130	3.543		5.118		1.102	0.945	1.555	2395	53110	12909	8848	16	M10 x 25	26	3.4	6.246	5.998	5.740	3065
95 x 135	3.740	+0	5.315	-0	1.102	0.945	1.555	2834	59748	13634	9573	18	M10 x 25	26	3.6	6.597	6.312	6.018	3640
100 x 145	3.937	-0.0035	5.709	+0.0035	1.299	1.024	1.850	3395	67862	13634	9428	14	M12 x 30	44	4.4	7.062	6.762	6.451	4373
110 x 155	4.331		6.102		1.299	1.024	1.850	3712	67125	12329	8703	14	M12 x 30	44	4.7	7.422	7.132	6.830	4811
120 x 165	4.724		6.496		1.299	1.024	1.850	4602	76714	12764	9283	16	M12 x 30	44	5.2	8.008	7.673	7.327	5998
130 x 180	5.118	+0 -0.004	7.087	-0 +0.004	1.496	1.339	2.047	6201	95155	11314	8123	20	M12 x 35	44	7.7	8.506	8.196	7.873	8122

Ordering example: RfN 7012

* B ≥ 2 l necessary

More sizes on request

Series	d	D	Further details
RfN 7012	42	75	SS (=stainless steel)

■ Mounting of Locking Assembly

The values for T, F_{ax}, P_W and P_N apply to Locking Assemblies installed in oiled condition.

■ Surface finishes

For shafts and hub bores

R_a = 125 RMS

■ Tolerances

We recommend the following mounting tolerances

shaft: k9-h9 · hub: N9-H9 - see table above

shaft: k11-h11 · hub: N11-H11

To avoid excessive deformations of the relatively thickwalled thrust rings, the Locking Assembly should be located as symmetrically as possible between shaft and hub bore. If the shaft is smaller than nominal d, the bore should exceed nominal D to the same extent and vice versa. The true running out quality is determined by the direct centering between shaft and hub.

■ Location of several Locking Assemblies RfN 7012 stainless

If several Locking Assemblies are to be installed the transmission values of the table can be added when the Locking Assemblies are located within a distance of 4 x L₁.

■ Change of screw tightening torques

The Locking Assemblies are generally equipped with A2-70 grade screws. A reduction of the screw tightening torque is possible. (Please contact our specialists for assistance).

■ Auxiliary Threads

To facilitate removal, the front thrust rings have pullout threads.

Characteristics

Self-centering 2-piece Locking Assemblies for medium torques. During installation, minor axial displacement of the hub occurs in opposite direction of the screw head. Due to the small number of screws, cost savings during installation are insured. For disassembly only few release screws are required.

We recommend the following mounting tolerances: **shaft: h8 · hub: H8 - see adjacent table**

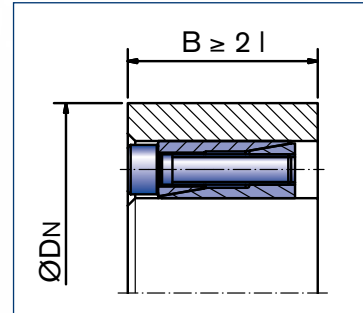

Locking Assembly RfN 7061 Typical installation

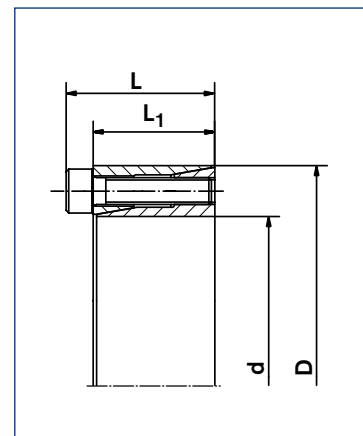

Locking Assembly RfN 7061 · Dimensions

STAINLESS

Locking Assembly dimensions							Transmissible torques or axial forces		Surface Pressure		Locking screws DIN EN ISO 4762-A2-70			Weight
d x D	d	C ₁	D	C ₂	L ₁	L	T	F _{ax}	Shaft P _w	Hub P _N	n	Thread d _G	T _A	lbs
mm	Inch						lb-ft	lbs	psi			mm	lb-ft	
6 x 16	0.236	+0 -0.001	0.630	-0 +0.001	0.433	0.531	2.2	202	7107	2756	3	M 2.5	0.4	0.03
7 x 17	0.276		0.669		0.433	0.531	2.2	202	6092	2466	3	M 2.5	0.4	0.03
8 x 18	0.315		0.709		0.433	0.531	3.0	202	5367	2466	3	M 2.5	0.4	0.03
9 x 20	0.354		0.787		0.512	0.610	4.4	270	5367	2466	4	M 2.5	0.4	0.04
10 x 20	0.394		0.787		0.512	0.610	4.4	270	4786	2466	4	M 2.5	0.4	0.04
11 x 22	0.433		0.866		0.512	0.610	5.2	270	4351	2176	4	M 2.5	0.4	0.05
12 x 22	0.472		0.866		0.512	0.610	5.2	270	3771	2176	4	M 2.5	0.4	0.05
14 x 26	0.551		1.024		0.669	0.787	9.6	427	4061	2176	4	M 3	0.7	0.09
15 x 28	0.591		1.102		0.669	0.787	10	427	3771	2031	4	M 3	0.7	0.10
16 x 32	0.630		1.260		0.669	0.827	21	787	6527	3336	4	M 4	1.6	0.15
17 x 35	0.669		1.378		0.827	0.984	22	787	4932	2466	4	M 4	1.6	0.20
18 x 35	0.709		1.378		0.827	0.984	24	787	4641	2466	4	M 4	1.6	0.19
19 x 35	0.748		1.378		0.827	0.984	25	787	4496	2466	4	M 4	1.6	0.19
20 x 38	0.787		1.496		0.827	1.024	41	1237	6527	3481	4	M 5	3.1	0.22
22 x 40	0.866	1.575	0.827	1.024	45	1237	5947	3336	4	M 5	3.1	0.24		
24 x 47	0.945	1.850	1.024	1.260	71	1799	6382	3336	4	M 6	5.4	0.44		
25 x 47	0.984	1.850	1.024	1.260	74	1799	6237	3336	4	M 6	5.4	0.42		
28 x 50	1.102	1.969	1.024	1.260	155	3372	8268	4641	4	M 6	5.4	0.44		
30 x 55	1.181	2.165	1.024	1.260	162	3372	7832	4206	6	M 6	5.4	0.60		
32 x 55	1.260	2.165	1.024	1.378	177	3372	7252	4206	6	M 6	5.4	0.55		
35 x 60	1.378	2.362	1.142	1.378	258	4496	7977	4641	8	M 6	5.4	0.79		
38 x 65	1.496	2.559	1.142	1.378	280	4496	7397	4206	8	M 6	5.4	0.95		
40 x 65	1.575	2.559	1.142	1.378	295	4496	6962	4206	8	M 6	5.4	0.88		

Ordering example: RfN 7061

* B ≥ 2 l necessary

More sizes on request

Series	d	D	Further details
RfN 7061	20	38	SS (=stainless steel)

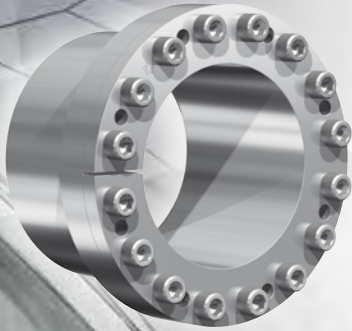

Characteristics

Specially small dimensioned self-centering Locking Assembly without axial displacement. As the locking screws are located out of the actual clamping area and the pressures are relatively low, the hub can be designed economically small.

We recommend the following mounting tolerances: **shaft: h8 · hub: H8 - see adjacent table**

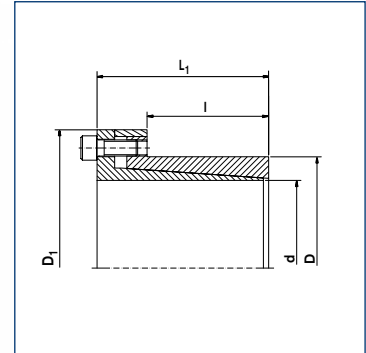

Locking Assembly RfN 7110 - Dimensions

STAINLESS

Locking Assembly dimensions									Transmissible torques or axial forces		Surface Pressure		Locking screws DIN EN ISO 4762-A2-70			Weight
d x D	d	C ₁	D	C ₂	D ₁	l	L ₁	T	F _{ax}	Shaft P _w	Hub P _N	n	Thread d _G	T _A	WT	
mm	Inch							lb-ft	lbs	psi			mm	lb-ft	lbs	
10 x 16	0.394		0.630		1.142	0.551	1.063	16	899	11894	7397	4	M4	1.5	0.1	
11 x 18	0.433		0.709		1.260	0.551	1.102	18	899	10878	6672	4	M4	1.5	0.2	
12 x 18	0.472		0.709		1.260	0.551	1.102	19	899	10008	6672	4	M4	1.5	0.2	
14 x 23	0.551		0.906		1.496	0.551	1.102	22	899	8558	5222	4	M4	1.5	0.3	
15 x 24	0.591		0.945		1.732	0.630	1.457	54	2248	15520	9718	4	M6	5.9	0.5	
16 x 24	0.630		0.945		1.732	0.630	1.457	58	2248	14650	9718	4	M6	5.9	0.4	
17 x 25	0.669	+0	0.984	-0	1.772	0.630	1.457	62	2248	14069	9138	4	M6	5.9	0.5	
18 x 26	0.709	-0.001	1.024	+0.001	1.850	0.709	1.535	64	2248	11459	7977	4	M6	5.9	0.5	
19 x 27	0.748		1.063		1.929	0.709	1.535	68	2248	10878	7687	4	M6	5.9	0.6	
20 x 28	0.787		1.102		1.969	0.709	1.535	72	2248	10298	7397	4	M6	5.9	0.6	
22 x 32	0.866		1.260		2.126	0.984	1.811	77	2248	6817	4641	4	M6	5.9	0.7	
24 x 34	0.945		1.339		2.205	0.984	1.811	129	3372	9283	6527	6	M6	5.9	0.8	
25 x 34	0.984		1.339		2.205	0.984	1.811	133	3372	8993	6527	6	M6	5.9	0.8	
28 x 39	1.102		1.535		2.402	0.984	1.811	148	3372	7977	5802	6	M6	5.9	0.9	
30 x 41	1.181		1.614		2.441	0.984	1.811	162	3372	7397	5512	6	M6	5.9	0.9	
32 x 43	1.260		1.693		2.559	0.984	1.811	229	4272	9283	6962	8	M6	5.9	1.0	
35 x 47	1.378		1.850		2.598	1.260	2.087	251	4272	6672	4932	8	M6	5.9	1.1	
38 x 50	1.496		1.969		2.835	1.260	2.087	273	4272	6092	4641	8	M6	5.9	1.3	
40 x 53	1.575	+0	2.087	-0	2.953	1.260	2.087	288	4272	5802	4351	8	M6	5.9	1.5	
42 x 55	1.654	-0.0015	2.165	+0.0015	3.071	1.260	2.087	302	4272	5512	4206	8	M6	5.9	1.6	
45 x 59	1.772		2.323		3.386	1.772	2.756	605	8094	6962	5222	8	M8	13.3	2.5	
48 x 62	1.890		2.441		3.425	1.772	2.756	649	8094	6527	5077	8	M8	13.3	2.5	
50 x 65	1.969		2.559		3.622	1.772	2.756	671	8094	6237	4786	8	M8	13.3	2.9	

Ordering example: RfN 7110

[More sizes on request](#)

Series	d	D	Further details
RfN 7110	32	43	SS (= stainless steel)



Unslit



Slit

STAINLESS

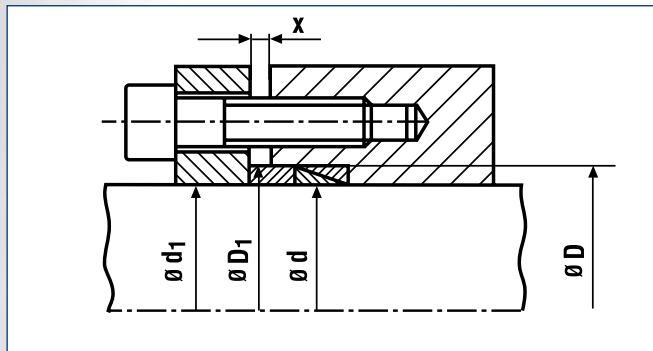

Locking Element RINGFEDER® RfN 8006 stainless · Typical installation

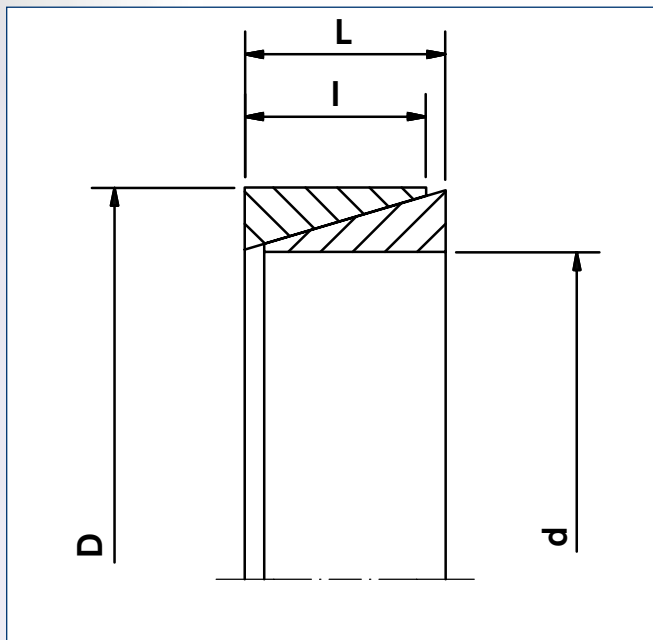

Locking Elements RINGFEDER® RfN 8006 stainless · Dimensions

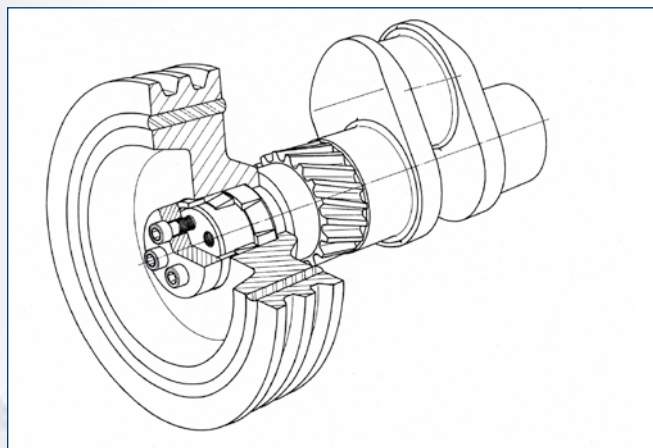

V-belt pulley

Locking Element dimensions										Clamping force		Transmissible torques or axial forces		Locking Elements				Weight	Diameter spacer sleeve		T _{max}
d x D	d	C ₁	C _b	D	C ₂	L	I	A _t	F ₀	F _{A'}	T	F _{ax}	1	2	3	4	WT	inside d ₁	outside D ₁		
mm	Inch									psi	lb-ft	lbs	Inch				lbs 10 ⁻³	Inch		lb-ft	
* 6 x 9	0.236			0.354	-0	0.177	0.146	0.107	-	832	1.5	149	0.079	0.079	0.118	0.118	3.31	0.240	0.350	4.6	
* 7 x 10	0.276			0.394	+0.0006	0.177	0.146	0.124	-	989	2.0	174	0.079	0.079	0.118	0.118	3.09	0.280	0.390	6.0	
* 8 x 11	0.315			0.433		0.177	0.146	0.140	-	1124	2.6	198	0.079	0.079	0.118	0.118	3.31	0.319	0.429	7.7	
9 x 12	0.354			0.472		0.177	0.146	0.163	1709	1281	3.4	228	0.079	0.079	0.118	0.118	3.75	0.358	0.469	5.2	
10 x 13	0.394			0.512		0.177	0.146	0.180	1551	1416	4.1	252	0.079	0.079	0.118	0.118	3.97	0.398	0.508	7.2	
11 x 14	0.433			0.551		0.177	0.146	0.198	1686	1551	4.7	270	0.079	0.079	0.118	0.118	4.41	0.437	0.547	8.6	
12 x 15	0.472			0.591		0.177	0.146	0.215	1551	1686	5.9	300	0.079	0.079	0.118	0.118	4.85	0.476	0.587	11.1	
13 x 16	0.512			0.630		0.177	0.146	0.234	1439	1844	7.1	326	0.079	0.079	0.118	0.118	5.07	0.516	0.626	13.7	
14 x 18	0.551			0.709		0.248	0.209	0.361	2518	2833	11.8	504	0.118	0.118	0.157	0.197	10.8	0.555	0.705	20.2	
15 x 19	0.591			0.748		0.248	0.209	0.388	2406	3035	13.6	540	0.118	0.118	0.157	0.197	11.7	0.594	0.744	24	
16 x 20	0.630			0.787		0.248	0.209	0.412	2271	3237	15.3	574	0.118	0.118	0.157	0.197	12.1	0.634	0.783	29	
17 x 21	0.669			0.827		0.248	0.209	0.439	2136	3440	17.1	612	0.118	0.118	0.157	0.197	12.8	0.673	0.823	33	
18 x 22	0.709			0.866		0.248	0.209	0.465	2046	3642	19.5	647	0.118	0.118	0.157	0.197	13.5	0.713	0.862	38	
19 x 24	0.748			0.945		0.248	0.209	0.490	2833	3844	21.2	682	0.118	0.118	0.157	0.197	17.2	0.756	0.937	54	
20 x 25	0.787			0.984		0.248	0.209	0.516	2698	4047	24	719	0.118	0.118	0.157	0.197	18.1	0.795	0.976	61	
22 x 26	0.866			1.024		0.248	0.209	0.567	2023	4451	28	791	0.118	0.118	0.157	0.197	15.9	0.874	1.016	58	
24 x 28	0.945			1.102		0.248	0.209	0.620	1866	4856	34	863	0.118	0.118	0.157	0.197	17.4	0.953	1.094	72	
25 x 30	0.984			1.181		0.248	0.209	0.645	2226	5058	37	899	0.118	0.118	0.157	0.197	22.1	0.992	1.173	100	
28 x 32	1.102			1.260		0.248	0.209	0.722	1664	5665	46	1007	0.118	0.118	0.157	0.197	19.8	1.110	1.252	100	
30 x 35	1.181			1.378		0.248	0.209	0.773	1911	6070	53	1079	0.118	0.118	0.157	0.197	26.5	1.189	1.370	148	
32 x 36	1.260			1.417		0.248	0.209	0.826	1754	6475	60	1151	0.118	0.118	0.157	0.197	22.1	1.268	1.409	131	
35 x 40	1.378			1.575		0.276	0.236	1.021	2271	8004	81	1421	0.118	0.118	0.157	0.197	44.1	1.386	1.567	199	
36 x 42	1.417			1.654		0.276	0.236	1.051	2698	8228	87	1475	0.118	0.118	0.157	0.197	44.1	1.425	1.646	259	
38 x 44	1.496			1.732		0.276	0.236	1.110	2473	8701	96	1547	0.118	0.118	0.157	0.197	44.1	1.504	1.724	290	
40 x 45	1.575			1.772		0.315	0.260	1.285	3147	10117	117	1790	0.118	0.157	0.197	0.236	44.1	1.583	1.764	252	
42 x 48	1.654			1.890		0.315	0.260	1.349	3507	10567	129	1871	0.118	0.157	0.197	0.236	66	1.661	1.882	342	
45 x 52	1.772			2.047		0.394	0.339	1.883	5868	14838	194	2626	0.118	0.157	0.197	0.236	110	1.780	2.039	442	
48 x 55	1.890			2.165		0.394	0.339	2.009	5531	15737	220	2806	0.118	0.157	0.197	0.236	110	1.898	2.157	510	
50 x 57	1.969			2.244		0.394	0.339	2.093	5283	16412	239	2914	0.118	0.157	0.197	0.236	110	1.976	2.236	559	
55 x 62	2.165			2.441		0.394	0.339	2.302	4901	17986	289	3201	0.118	0.157	0.197	0.236	110	2.173	2.433	685	
56 x 64	2.205			2.520		0.472	0.409	2.835	6610	22257	363	3957	0.118	0.157	0.197	0.276	154	2.213	2.512	797	
60 x 68	2.362			2.677		0.472	0.409	3.036	6160	23831	416	4227	0.118	0.157	0.197	0.276	154	2.370	2.669	929	
63 x 71	2.480			2.795		0.472	0.409	3.188	5913	24955	460	4460	0.118	0.157	0.197	0.276	176	2.488	2.787	1033	
65 x 73	2.559			2.874		0.472	0.409	3.291	5710	25854	490	4604	0.118	0.157	0.197	0.276	176	2.567	2.866	1106	
70 x 79	2.756			3.110		0.551	0.480	4.157	6969	32599	661	5755	0.118	0.197	0.236	0.276	243	2.768	3.098	1446	
71 x 80	2.795			3.150		0.551	0.480	4.216	6969	33049	685	5863	0.118	0.197	0.236	0.276	243	2.807	3.138	1490	
75 x 84	2.953			3.307		0.551	0.480	4.453	7779	34847	761	6187	0.118	0.197	0.236	0.276	265	2.965	3.295	1652	
80 x 91	3.150			3.583		0.669	0.591	5.840	10791	45638	1068	8094	0.157	0.197	0.236	0.315	265	3.161	3.571	2301	
85 x 96	3.346			3.780		0.669	0.591	6.206	10252	48561	1204	8633	0.157	0.197	0.236	0.315	441	3.358	3.768	2619	
90 x 101	3.543			3.976		0.669	0.591	6.570	9757	51484	1351	9173	0.157	0.197	0.236	0.315	441	3.555	3.965	2951	
95 x 106	3.740			4.173		0.669	0.591	6.936	9263	54406	1505	9712	0.157	0.197	0.236	0.315	485	3.752	4.161	3305	
100 x 114	3.937			4.488		0.827	0.736	9.102	13647	71268	2077	12590	0.157	0.236	0.276	0.354	882	3.949	4.476	4691	
110 x 124	4.331			4.882		0.827	0.736	10.011	14838	78462	2508	13849	0.157	0.236	0.276	0.354	882	4.343	4.870	5643	
120 x 134	4.724			5.276		0.827	0.736	10.921	13534	85432	2980	15108	0.157	0.236	0.276	0.354	1103	4.736	5.264	6771	
130 x 148	5.118			5.827		1.102	0.996	16.008	21628	125450	4750	22302	0.197	0.276	0.354	0.433	1874	5.134	5.811	10231	
140 x 158	5.512			6.220		1.102	0.996	17.239	20009	134892	5518	24101	0.197	0.276	0.354	0.433	2007	5.528	6.205	11942	
150 x 168	5.906			6.614		1.102	0.996	18.470	18997	144559	6314	25719	0.197	0.276	0.354	0.433	2139	5.921	6.598	13750	

* Only slit. For slit Locking Elements F₀ is eliminated in the calculation.

More sizes on request

Ordering example: RfN 8006 unslit

Series	d	D	Further details
RfN 8006	18	22	SS

Ordering example: RfN 8006 slit

Baureihe/Series	d	D	Further details
RfN 8006	18	22	SS-G (=stainless steel, slit)

Special Solutions



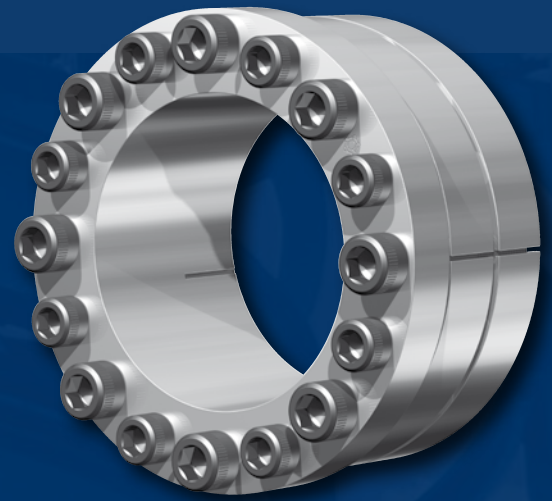

Locking Assemblies



Flange Couplings

Special Solution Locking Assemblies

Where the use of standard Locking Assemblies is not sufficient we develop special solutions optimized to specific customer requirements so that the parts are ideal for the specific application. In this way it is possible to have keyless connections for applications which were not previously possible.

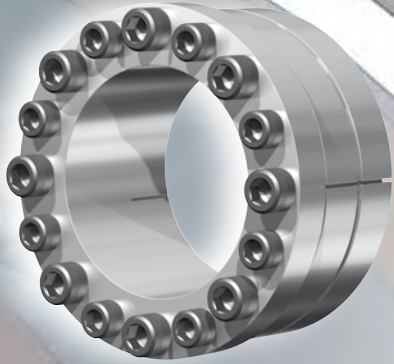

RfN 7006.2





Special Solution Flange Couplings

Flange Couplings are designed by us for the specific situation in order to offer the best possible solution for the transmitted torque, masses etc.



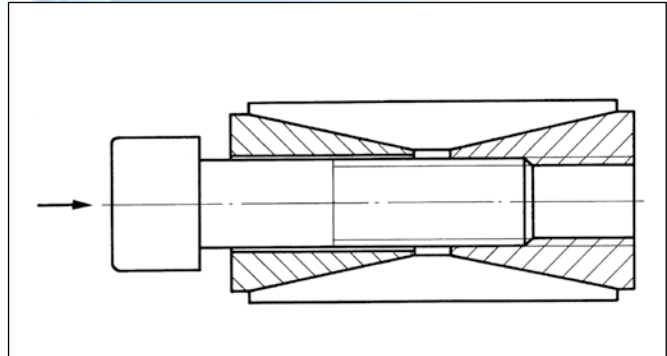
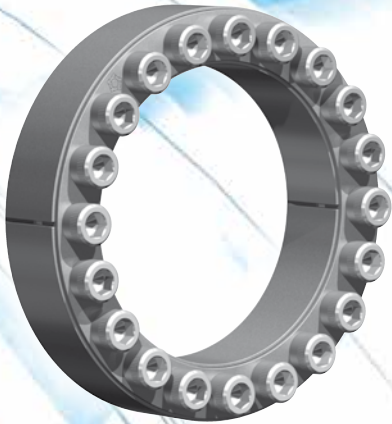

If the rear thrust ring does not automatically release, the screws have to be turned out by a few threads. Light tapping against the screw heads causes the rear thrust ring to spring backwards.

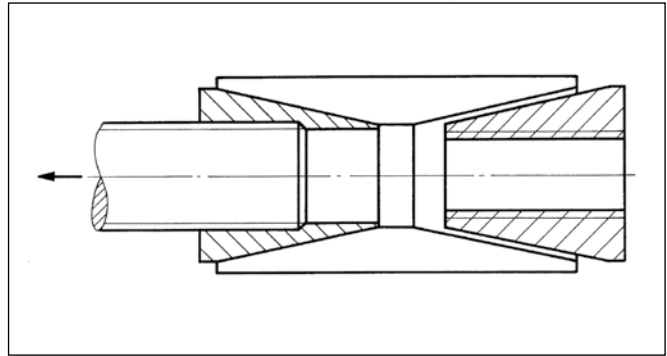

Should the front thrust ring jam, it is released in a similar way. The marked screws (washer) are removed from the pullout threads of the front thrust ring. The front thrust ring can be released and a Locking Assembly which may be deep in the hub bore can be removed by corresponding screws.

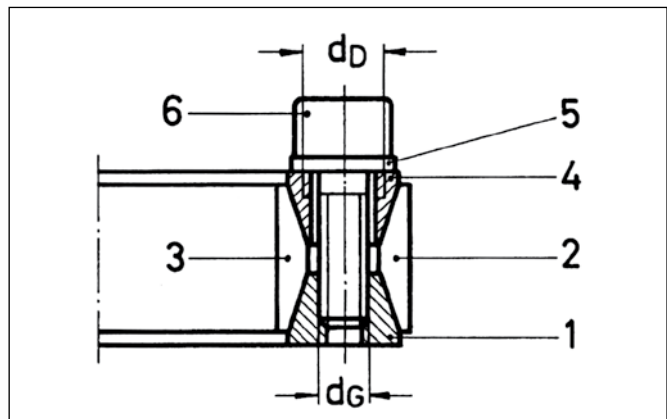

Locking Assembly RfN 7012-IN. Part description.

- 1 rear thrust ring
- 2 outer ring, slit
- 3 inner ring, slit
- 4 front thrust ring
- 5 washer
- 6 locking screw

Installation and removal instructions

Locking Assembly RfN 7012 / RfN 7012-IN, standard and stainless steel

Installation

Since the force is transmitted by contact pressure and friction between functional surfaces, condition of contact surfaces and proper tightening of the locking screws are of great importance.

1. All contact surfaces, including screw threads and screw head bearing surfaces, must be clean and slightly oiled. In this condition, the shaft, hub and Locking Assemblies are to be assembled. (Do not use Molybdenum Disulphide!)
2. Tighten locking screws lightly and align hub.
3. Tighten screws evenly in diametrically opposite sequence and do this in two or three stages up to the indicated tightening torque T_A .
4. Re-check tightening torque by applying it to all screws all the way around. If all screws have reached the max. tightening torque T_A , the assembly is completed.

Removal

RINGFEDER® Locking Assemblies RfN 7012 are not self-releasing. The taper of the individual rings is such that the inner and outer rings spring apart when the pressure is reduced by loosening the screws.

The washers under marked screws protect the auxiliary (removal) threads against damage; these washers must be replaced after having been used several times.

If force is needed to extract a Locking Assembly that has already been loosened (e. g. if the Locking Assembly has to be pushed against the weight of a heavy hub), any type of removal device may be used, but the screws must only be loosened and not screwed out too far. Thus a removal device can be used, provided the forces applied are kept low.

The auxiliary threads have only about 3-5 effective threads and are not cut right through. Do not use these holes for jack screws.

A previously used locking device may be reused only after visual inspection for surface damage and being thoroughly cleaned and re-lubricated!

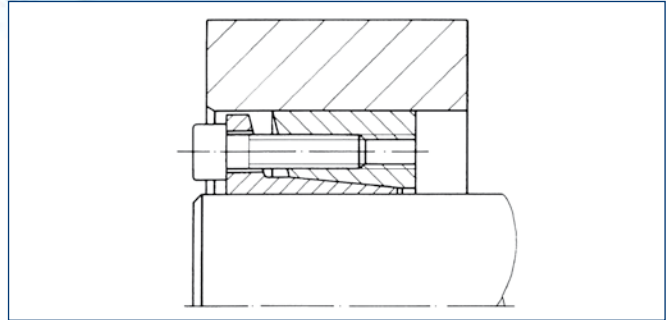
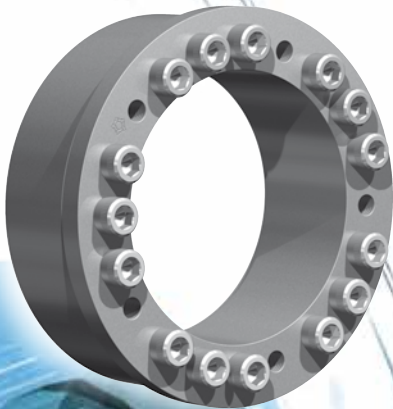
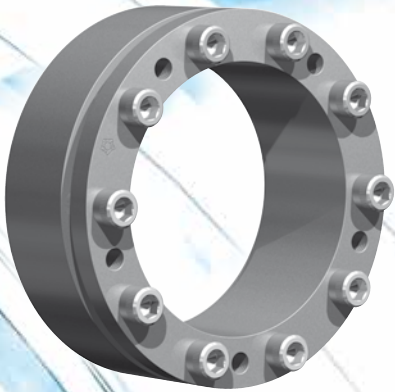

Installation of a Locking Assembly RfN 7013.0/7013.0-IN

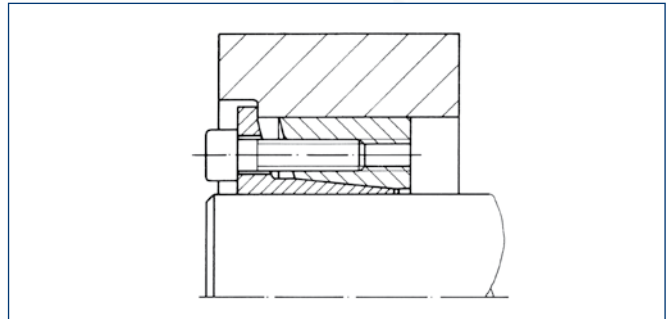

Installation of a Locking Assembly RfN 7013.1/7013.1-IN

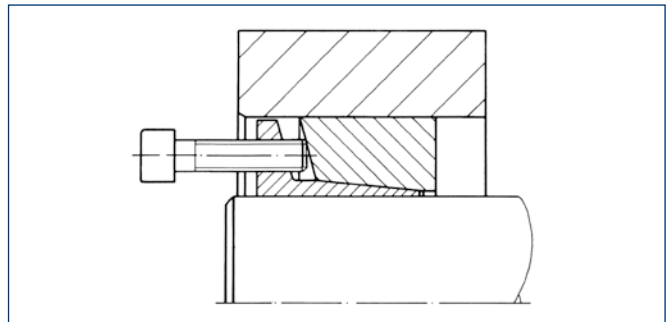

Removal of a Locking Assembly RfN 7013.0/7013.0-IN

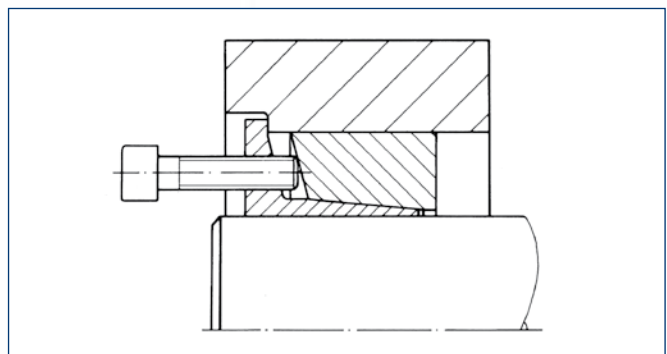

Removal of a Locking Assembly RfN 7013.1/7013.1-IN

Installation and removal instructions

Locking Assembly RfN 7013.0 / RfN 7013.0-IN,
RfN 7013.1 / RfN 7013.1-IN standard and stain-
less steel

Installation

Since the force is transmitted by contact pressure and friction between functional surfaces, condition of contact surfaces and proper tightening of the locking screws are of great importance.

1. All contact surfaces, including screw threads and screw head bearing surfaces, must be clean and slightly oiled. (Do not use Molybdenum Disulphide!). In this condition, the shaft, hub and Locking Assemblies are to be assembled.
2. Tighten locking screws lightly and align hub.
3. Tighten screws evenly in diametrically opposite sequence and do this in two or three stages up to the indicated tightening torque (T_A).
4. Re-check tightening torque by applying it to all screws all the way around. If all screws have reached the max. tightening torque T_A , the assembly is completed.

Removal

The Locking Assemblies RfN 7013 are to be removed in the following sequence:

1. Loosen all screws by a few turns.
2. Remove the screws adjacent to each jacking hole and screw them into these bores pressing off the outer ring. The connection is then released.
3. The connection can be either readjusted or disassembled. Remove the jack screws only after the Locking Assembly has been taken out of the hub.

Remove and clean dirty undamaged Locking Assemblies before re-use.

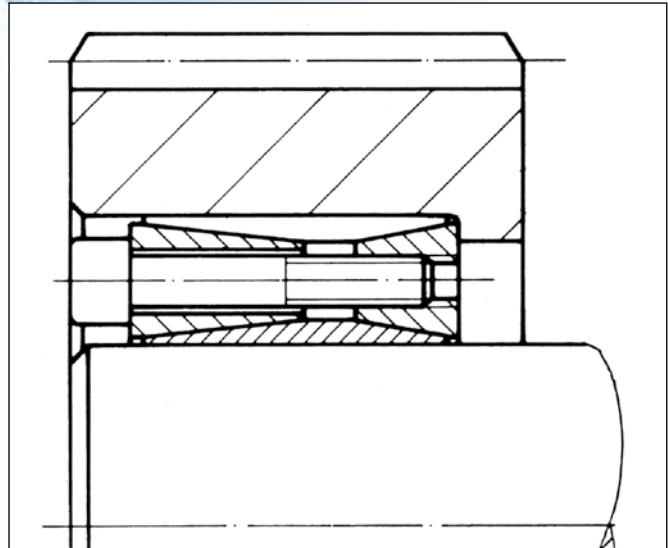
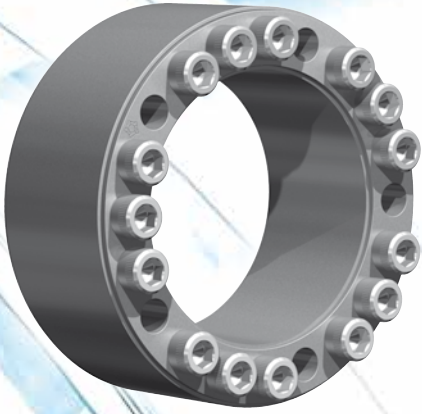

Locking Assembly not tightened

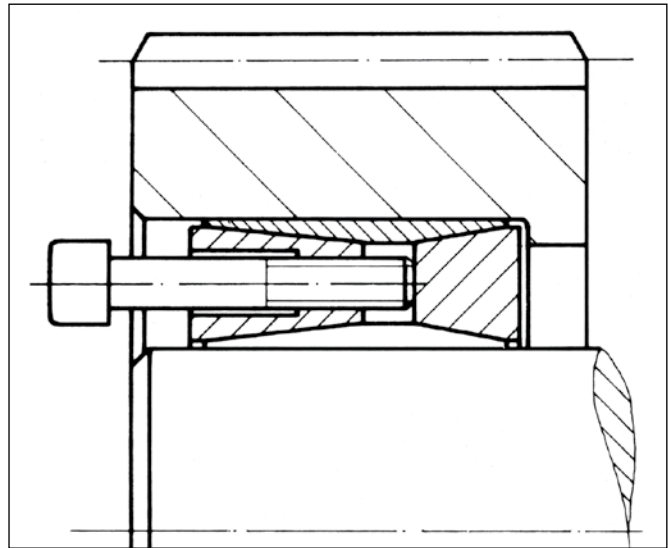

Locking Assembly with a screw in one of the release threads

Installation and removal instructions

Locking Assembly RfN 7014

Installation

Since the force is transmitted by contact pressure and friction between the functional surfaces, the condition of the contact surfaces and correct tightening of the locking screws are of great importance.

1. When originally packed, these Locking Assemblies are fitted with small metal packing pieces located in the slits of the inner and outer rings. These are for shipping purposes only and **MUST** be removed prior to installation.
2. All contact surfaces, including screw threads and screw head bearing surface, must be clean and slightly oiled (Do not use Molybdenum Disulphide!). In this condition, the shaft, hub, and Locking Assemblies are to be assembled.
3. Tighten locking screws lightly and align hub.
4. Tighten screws evenly in diametrically opposite sequence and do this in two or three stages up to the indicated final tightening torque (T_A).
5. Re-check tightening torque by applying it to all the screws. If all screws have reached the max. tightening torque T_A , the assembly is completed.

Removal

The Locking Assemblies RfN 7014 are to be removed as follows:

1. Loosen all screws by a few threads.
2. Remove the screws adjacent to each jacking hole and screw them into these holes. Since the rear thrust ring rests against either shaft or hub shoulder, the jack screws will automatically push apart both tapers, thus releasing the connection.
3. The connection can be either readjusted or disassembled. Remove the jack screws only after the Locking Assembly has been taken out of the hub.

Used Locking Assemblies must be replaced and slightly oiled prior to reinstallation. Note that the release threads of the front thrust ring have to be positioned opposite to undrilled spaces of the rear thrust ring. These threads are used for removal.

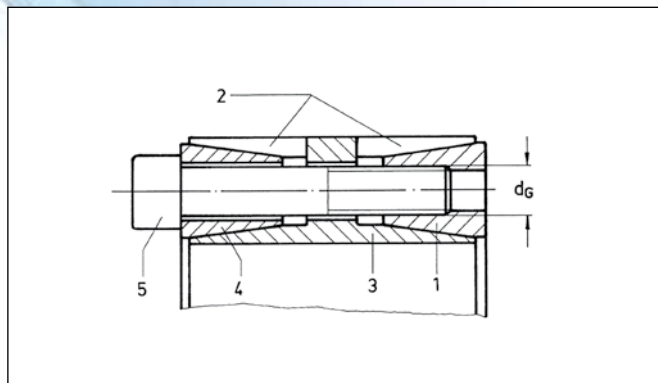
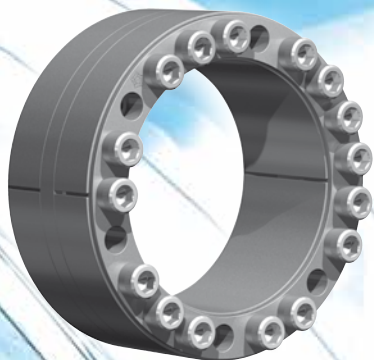

Figure 1: Locking Assembly RfN 7015. Part description.

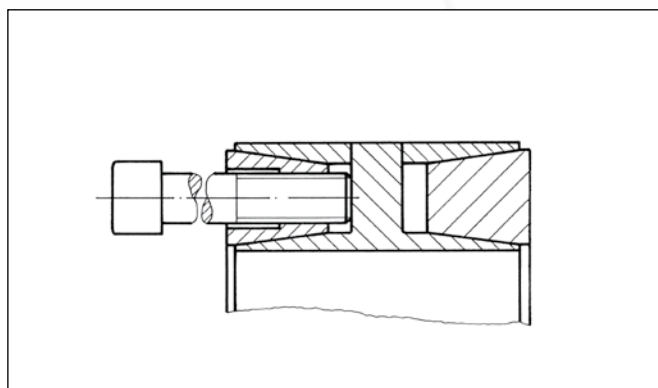

Figure 2: Removal front thrust ring

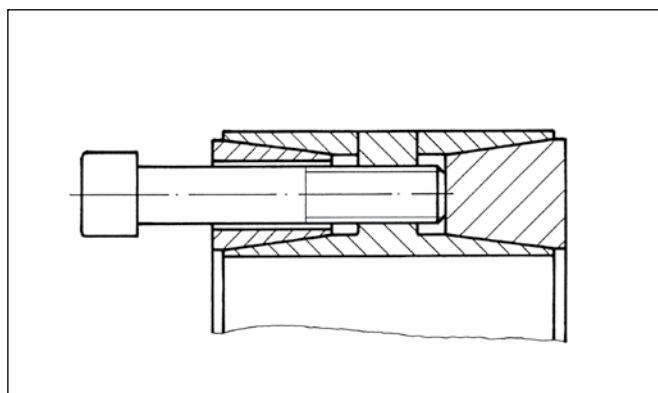

Figure 3: Removal rear thrust ring

Figures for RfN 7515 see page 80

Installation and removal instructions

Locking Assembly RfN 7015.0, 7015.1, 7515

Installation

Since the force is transmitted by contact pressure and friction between functional surfaces, condition of contact surfaces and proper tightening of the locking screws are of great importance (see point 1).

1. All contact surfaces, including screw threads and screw head bearing surface, must be clean and slightly oiled (Do not use Molybdenum Disulphide!). In this condition, the shaft, hub and Locking Assemblies are to be assembled.
 - 1.1 Unscrew all locking screws far enough so that only few threads are engaged in the rear thrust ring. For shipping purposes, these screws have been screwed in quite deep.
 - 1.2 With larger Locking Assemblies, it is advantageous to insert several locking screws into the corresponding threads of the front thrust ring according to Fig. 2 and push against them.
2. After the Locking Assembly is placed in position, slightly tighten all locking screws (screwed into the rear thrust ring) and make final alignment and adjustment of the connection.
3. Tighten screws evenly in diametrically opposite sequence and do this in two or three stages up to the indicated tightening torque T_A .
4. Re-check tightening torque by applying it to all screws all the way around. If all screws have reached the max. tightening torque T_A , the assembly is completed.

Used Locking Assemblies have to be cleaned and slightly oiled prior to installation and re-assembled according to Fig. 1

When re-assembling, it is important to make sure that all threaded holes of the rear thrust ring (1) are in line with the holes in web of inner ring (3) and front thrust ring (4). Threaded removal holes in front thrust ring must be located opposite blank spaces in web of inner ring, and the threaded removal holes in web of inner ring must be located opposite blank spaces of rear thrust ring, see Fig. 1.

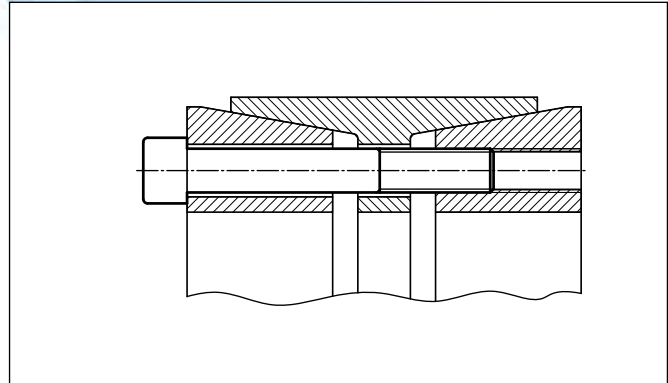

Figure 1: Locking Assembly RfN 7015. Part description.

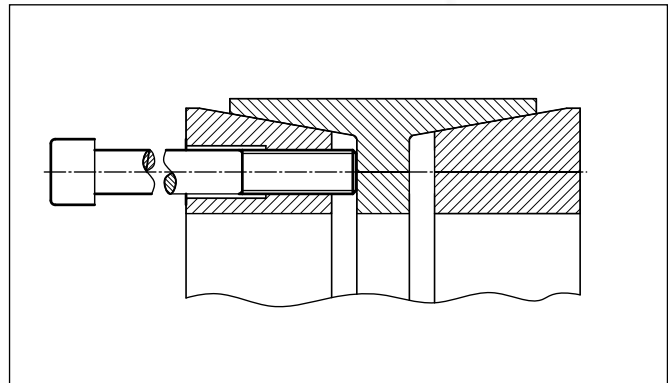

Figure 2: Removal front thrust ring

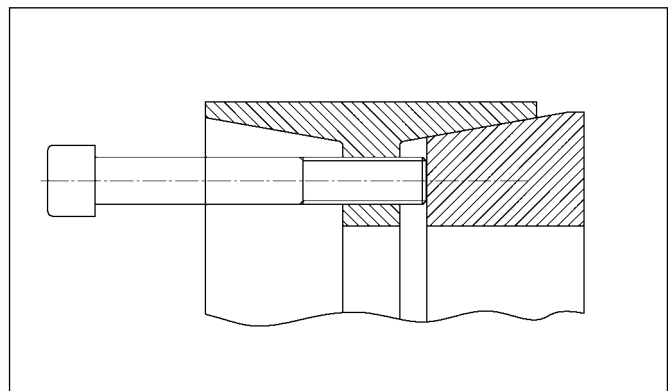

Figure 3: Removal rear thrust ring

Figures for RfN 7515 see page 78

Installation and removal instructions

Locking Assembly RfN 7015.0, 7015.1, 7515

Removal

The Locking Assemblies RfN 7015 are to be removed as follows:

1. Loosen all screws by a few turns.
2. Remove the screws adjacent to each threaded bore and screw them into these bores.
 - 2.1 The front thrust ring is released by having the jack screws pressed against the web of the inner ring (see Fig. 2).
 - 2.2 At RfN 7015 series, the rear thrust ring is released same way corresponding to illustration 3.
At RfN 7515 the front thrust ring has to be removed first, before the release threads for the rear thrust ring are accessible.
3. Pull or push hub and Locking Assemblies off the shaft.
The jack screws should be removed only after the Locking Assembly has been taken out of the hub.

Dis-assemble and clean dirty, undamaged Locking Assemblies before re-use.

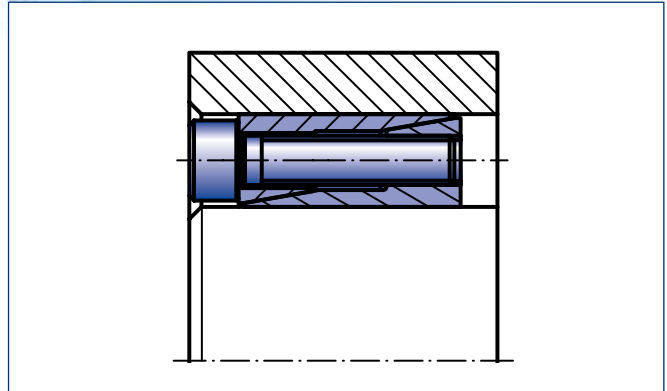

Installation of a Locking Assembly RfN 7061

Installation and removal instructions

Locking Assembly RfN 7061

Installation

Since the force is transmitted by contact pressure and friction between functional surfaces, the condition of the contact surfaces and proper tightening of the locking screws are of great importance (see point 1.).

1. All contact surfaces, including screw threads and screw head bearing surfaces, must be clean and slightly oiled (Do not use Molybdenum Disulphide!). In this condition the shaft, hub and Locking Assembly are to be assembled.
2. Tighten locking screws lightly and align hub.
3. Tighten screws evenly in diametrically opposite sequence and do so in two or three stages up to the indicated tightening torque.
4. Re-check tightening torque by applying it to all screws all the way around. If all screws have reached the max. tightening torque T_A , the assembly is completed.

Removal

The Locking Assemblies RfN 7061 are to be removed in the following sequence:

1. Loosen all screws by a few turns.
2. Remove the screws adjacent to each threaded jacking hole and screw them into these bores.
3. Tighten the jacking screws, starting with the positions furthest away from the slit first, in several stages until the connection is released.
4. The connection can then either be readjusted or disassembled. Remove the jacking screws only after the Locking Assembly has been removed from the hub.

Dismount and clean dirty undamaged Locking Assemblies before re-use and slightly oil them as described in point 1. of the installation instructions.

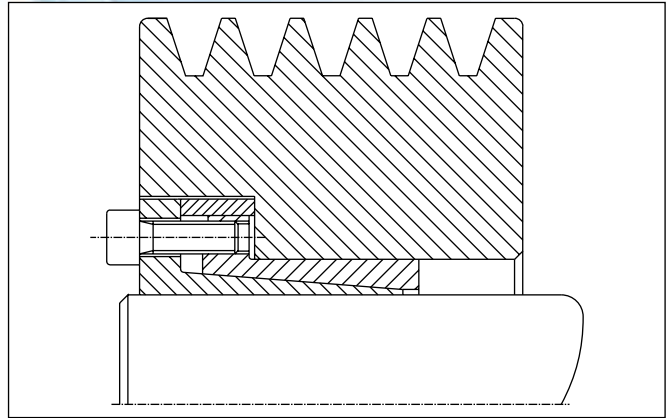

Pulley mounted using one Locking Assembly RINGFEDER® RfN 7110.

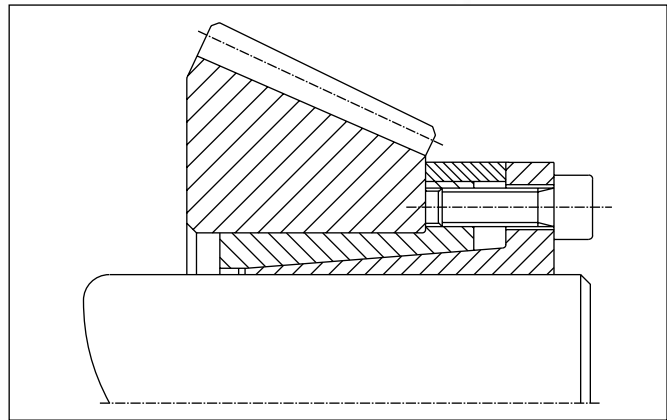

Bevel gear mounted with one Locking Assembly RfN 7110. During mounting the axial position of the bevel gear remains unchanged.

Installation and removal instructions

Locking Assembly RfN 7110 stainless

Installation

Since the force is transmitted by contact pressure and friction between functional surfaces, the condition of the contact surfaces and proper tightening of the locking screws are of great importance (see point 1.).

1. All contact surfaces, including screw threads and screw head bearing surfaces, must be clean and slightly oiled (Do not use Molybdenum Disulphide!). In this condition the shaft, hub and Locking Assembly are to be assembled.

2. Tighten locking screws lightly and align hub.

3. Tighten screws evenly in diametrically opposite sequence and do so in two or three stages up to the indicated tightening torque.

4. Re-check tightening torque by applying it to all screws all the way around. If all screws have reached the max. tightening torque T_A , the assembly is completed.

Removal

The Locking Assemblies RfN 7110 are to be removed in the following sequence:

1. Loosen all screws by a few turns.

2. Remove the screws adjacent to each threaded jacking hole and screw them into these bores.

3. Tighten the jacking screws, starting with the positions furthest away from the slit first, in several stages until the connection is released.

4. The connection can then either be readjusted or disassembled. Remove the jacking screws only after the Locking Assembly has been removed from the hub.

Dismount and clean dirty undamaged Locking Assemblies before re-use and slightly oil them as described in point 1 of the mounting instructions.



Unslit

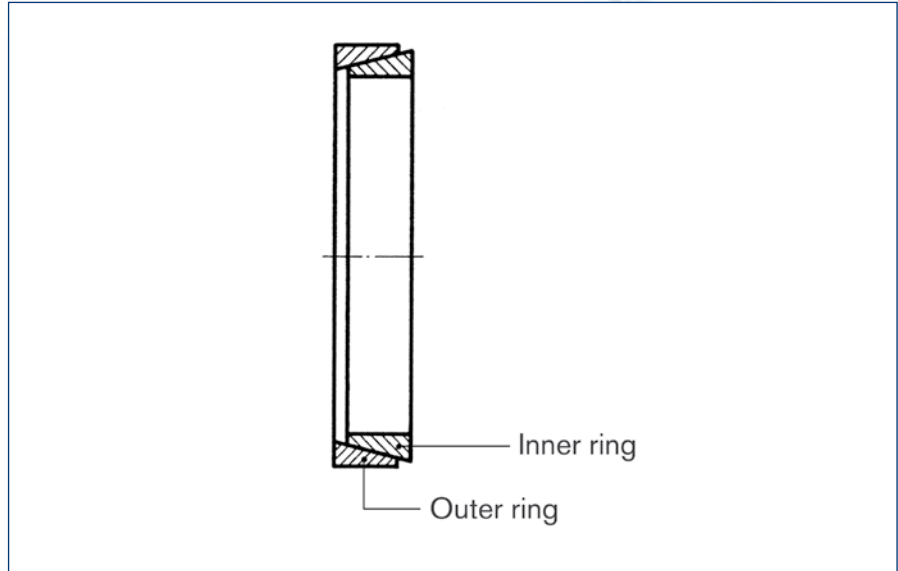

Locking Element RfN 8006 /GSA · View and section



Slit

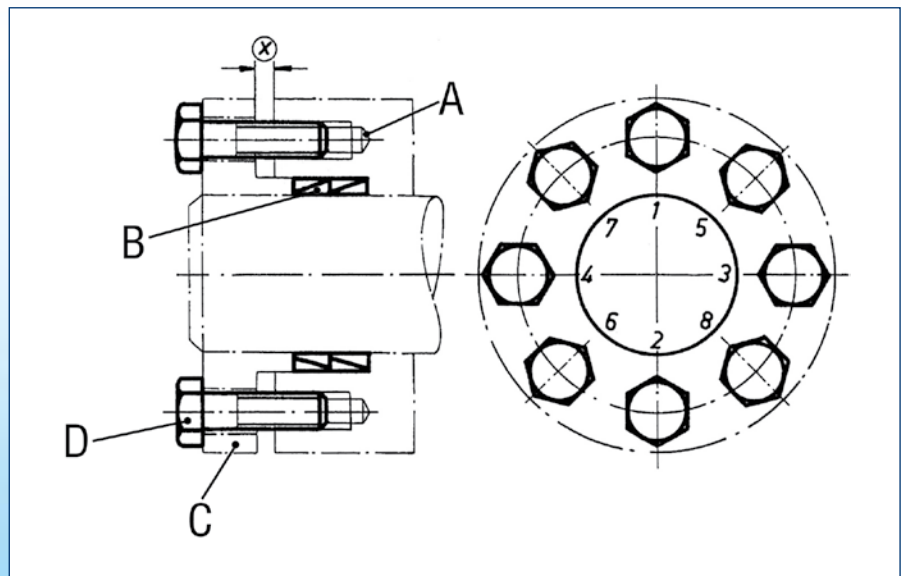

Tightening of the locking screws and distance x

Installation and removal instructions

Locking Element RfN 8006/GSA

Installation

Since the force is transmitted by contact pressure and friction between functional surfaces, condition of contact surfaces and proper tightening of the locking screws are of great importance (see point 1).

1. All contact surfaces, including screw threads and screw head contact surface, must be clean and slightly oiled.
2. Fit the parts in the following order:
A = Hub
Insert the Locking Element rings (B) according to the assembly drawing (both parts must be easy to install and must not jam under any circumstances).
C = Insert clamp plate (spacer sleeve if necessary) or clamp plate with collar. Ensure that both parts are easy to move.
D = Locking screws

Carefully oil the locking screws before assembly. This applies in particular to the screw head seat. **ATTENTION:** Do not use molybdenum disulphide! The screws must turn easily and to an adequate depth. Do not use spring washers or serrated locking washers.

3. Tighten locking screws lightly and align hub.
4. Tighten screws evenly in diametrically opposite sequence and do this with a torque wrench in several stages up to the indicated tightening torque (T_A).
5. Re-check tightening torque by applying it to all screws all the way around. If all screws have reached the max. tightening torque T_A , the assembly is completed.
6. Check distance x:
The thrust ring must never contact the face of the hub. The gap between thrust ring and hub face should be as uniform as possible.

Removal

1. Loosen all screws one after the other in several stages.
2. Remove the flange.
3. Take out the locking elements – the Locking Elements release automatically after the screws have been loosened. If not, light tapping is enough to start the releasing process.

Fax Inquiry

To get a design proposal for RINGFEDER® shaft-hub-connections

Maryland Metrics P.O. Box 261 Owings Mills, MD 21117 USA

Fax (410)358-3142 (800)872-9329

From

Company	<input type="text"/>		
Attention	<input type="text"/>	Dept.	<input type="text"/>
Address	<input type="text"/>		
Phone	<input type="text"/>	Fax	<input type="text"/>
E-Mail	<input type="text"/>		

Please have someone contact me at the following number or email address:

To make it easier for our technical staff and to avoid errors or mistakes your inquiry should include the following information:

Information for technical service

Expected maximum loads:

Max. torque	T max.	=	<input type="text"/>	lb-ft
Max. bending moment	M max.	=	<input type="text"/>	lb-ft
Max. axial load	F max.	=	<input type="text"/>	lbs
Max. radial load	F _r max.	=	<input type="text"/>	lbs

Dimensions, materials:

Shaft diameter	d _w	=	<input type="text"/>	Inches
In case of hollow shaft, internal diameter	d _B	=	<input type="text"/>	Inches
Speed	n	=	<input type="text"/>	rpm
Hub outside diameter	D _N	=	<input type="text"/>	lbs
Hub width	B	=	<input type="text"/>	Inches
Hub material yield strength	R _{p0.2N}	=	<input type="text"/>	psi
Shaft material yield strength	R _{p0.2W}	=	<input type="text"/>	psi
Ambient temperature	Temp.	=	<input type="text"/>	degree F

Additional information:

Please send a drawing or sketch together with your inquiry!

Delivery Program



Locking Devices



Locking Assemblies



Locking Elements



Shrink Discs®



Smart-Lock

Damping Technology



Friction Springs



DEFORM plus®
DEFORM plus® R



Fluid Elastomeric Damper

Special Solutions



Shaft Couplings

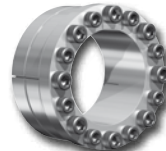

Locking Assemblies



Flange Couplings



Couplings



Magnetic Couplings



Metal Bellows Couplings



Servo-Insert Couplings



RING-flex® – torsionally rigid Disc Couplings



Safety Couplings



Line Shafts

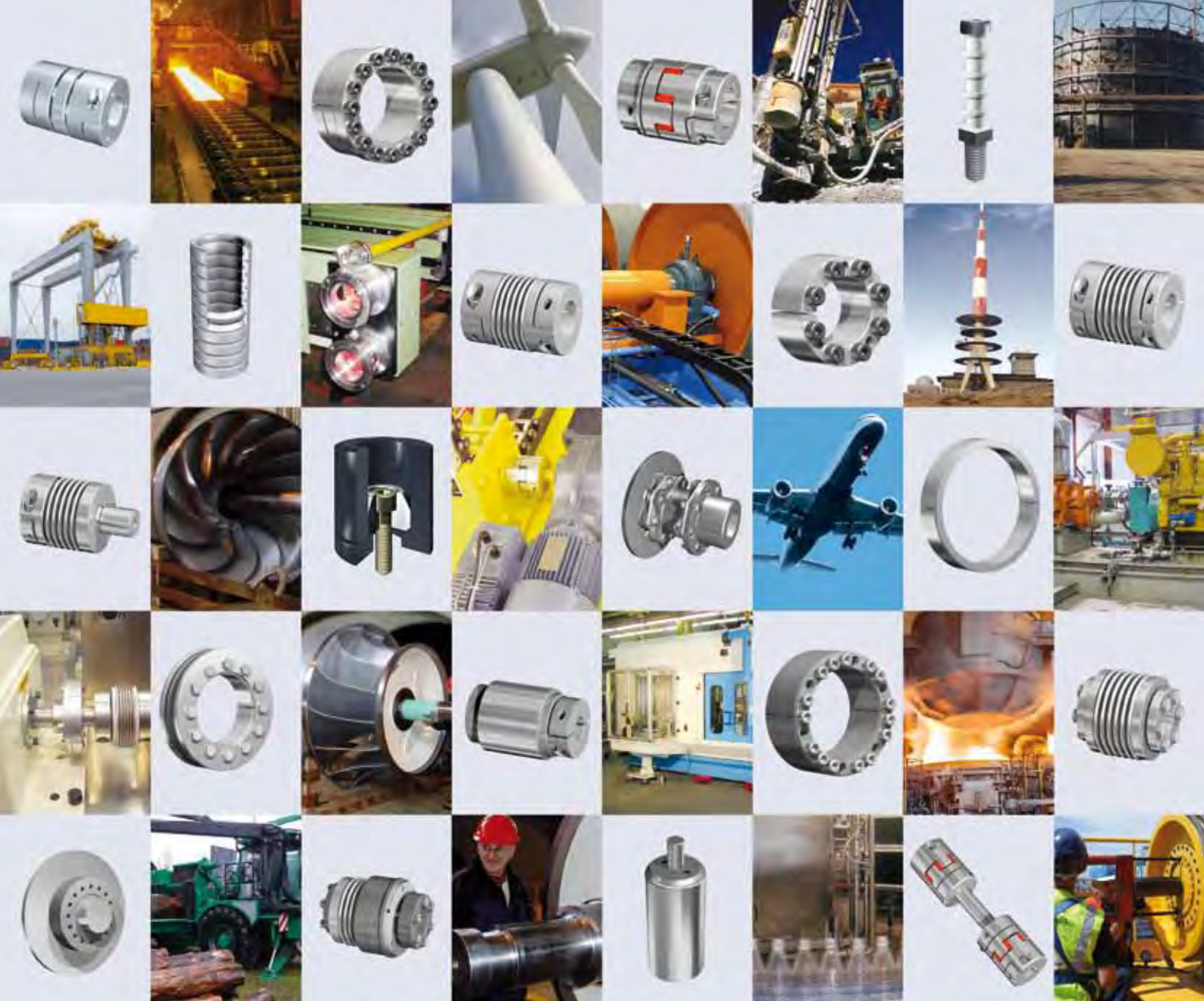

RINGFEDER POWER TRANSMISSION

RINGFEDER POWER TRANSMISSION GMBH

Werner-Heisenberg-Straße 18, D-64823 Groß-Umstadt, Germany · Phone: +49 (0) 6078 9385-0 · Fax: +49 (0) 6078 9385-100

RINGFEDER Products are available from **MARYLAND METRICS**

P.O. Box 261 Owings Mills, MD 21117 USA phones: (410)358-3130 (800)638-1830 faxes: (410)358-3142 (800)872-9329
 email: sales@mdmetric.com web: <http://mdmetric.com> RFQ form: <http://mdmetric.com/rfq.htm>