

Townsend Bearings



RHP Precision Bearings





RHP Super Precision Angular Contact Ball Bearings



Introduction	5
Materials and Limiting Temperatures	5
Dimensions	5
High Point of Radial Runout	5
Preload Levels	6
Universal Face Control	6
Matching	6
Sets of Bearings	6
Limiting Speeds	7
Lubrication	8
Oil Lubrication	8-9
Oil Type	9
Grease Lubrication	9
Axial Preload Values for Paired Angular Contact Ball Bearings	10-11
Axial Stiffness Values for Paired Angular Contact Ball Bearings	12-13
Bearing Tables Series 19 (79**)	14-15
Series 10 (70**)	16-17
Series 02 (72**)	18-19
Accuracy of Associated Components	20
Recommended Shaft and Housing Tolerances	21
Bearing Tolerances	22
Designation System	23



The NSK Group is one of the world's leading manufacturers of rolling bearings, automotive components, precision and mechatronic products.

The Group has over 40 manufacturing units around the world, employing over 23,000 people and is represented by sales offices and Authorised Distributors almost everywhere.

This brochure outlines the range of standard RHP Super Precision bearings. In addition to this standard range, NSK can provide super precision bearings such as higher speed capability angular contact ball bearings, cylindrical roller bearings, radial ball bearings and double direction thrust ball bearings. A complementary range of linear guides and ball screws are also available in addition to mechatronic products such as Robot Modules™ and Direct Drive Megatorque Motors®.

Modern machine tool building is placing increasing demands on bearing performance in terms of higher rotational accuracy and speeds. NSK can meet these needs with its extensive range of super precision bearings which demonstrate the following distinct features:-

- Extreme accuracy
- High rotational speed
- Quiet and smooth running
- Minimum friction and heat generation
- Controlled rigidity





RHP SUPER PRECISION ANGULAR CONTACT BALL BEARINGS

Introduction

Since single row angular contact ball bearings have a contact angle they can sustain significant axial loads in one direction together with radial loads. Because of their design two opposed bearings or a combination of more than two bearings must be used.

Three series of super precision bearings are available, ISO series 19, 10 and 02, with preferred contact angles of 15° and 25° (fig. 1). The standard cage is laminated phenolic resin which is outer ring guided. The material and design provide for high speed and quiet running.

The many combinations of contact angle and preload allow precise selection to cope with the most arduous requirements of speed and capacity.

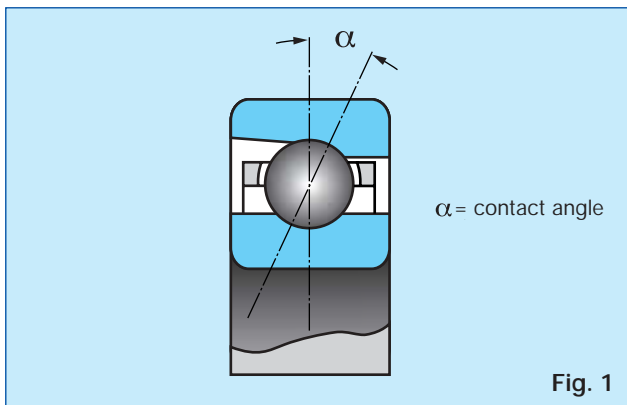

Fig. 1

Materials and Limiting Temperatures

The material for the rings and rolling elements is a carbon chrome bearing steel similar to BS970:534A99/535A99 or SAE52100. Components are through hardened and heat treated for stability and optimum life.

Maximum recommended operating temperature is 120°C for laminated phenolic resin caged bearings. If higher temperatures are required please consult NSK.

Dimensions

RHP Super Precision bearings are made in accordance with the International Standards Organisation's dimension plans. Full details are given in the bearing Tables 8-10 on pages 14-19.

The tolerances adopted conform to internationally recognised standards as shown in Table 1.

Precision grade P3 is an intermediate precision grade offering P2 runout tolerances with P4 external tolerances.

Table 1

RHP	P4	P3	P2
British Standards Institute (BS292)	EP7	-	EP9
Anti-Friction Bearing Manufacturers Association (AFBMA, Standard 20)	ABEC7	-	ABEC9
International Standards Organisation (ISO 492)	Class 4	-	Class 2

High Point of Radial Runout

RHP Super Precision bearings are marked at the point of maximum ring thickness. The high point of radial runout is indicated by a small circle or burnished spot on the inner ring face (fig. 2a) and by a 'V' line on the outside diameter of the outer ring (fig. 2b). The bearings can then be mounted with these marks axially aligned with each other and opposed to the shaft or housing eccentricities in order to minimise assembled runout. The 'V' line on the outer ring indicates the direction of the contact angle.

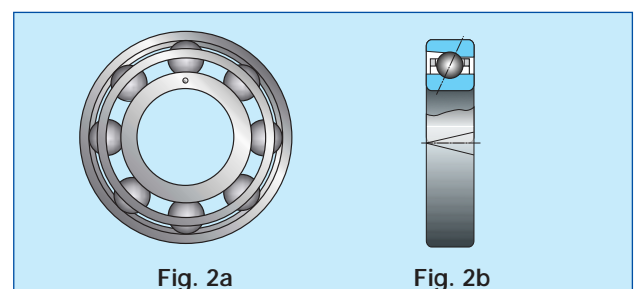

Fig. 2a

Fig. 2b



Preload Levels

The ring faces of angular contact ball bearings are adjusted at manufacture so that, when the bearings are mounted in a back-to-back or face-to-face arrangement and clamped together, a predetermined force exists between them. To provide for a wide variety of applications a choice of standard preload levels are available:

- Suffix **EL** = **extra light** preload
- Suffix **L** = **light** preload
- Suffix **M** = **medium** preload
- Suffix **H** = **heavy** preload

The preload most frequently selected is "light" which is suitable for use in most applications where loads and speeds are not extreme.

As preload levels affect the maximum speed capabilities of pairs or sets of bearings, reference should be made to the section on 'Limiting Speeds', page 7.

Although four preload levels are offered as standard, other preloads can be supplied to fulfil unusual technical requirements. In such cases advice should be sought from NSK.

Universal Face Control

Super precision angular contact ball bearings are universally faced. This means that the inner and outer rings are the same width and the relative positions of the faces on both sides of each bearing are adjusted to give the required preload. The bearings can be mounted back-to-back or face-to-face without affecting the preload value. When mounted in tandem they will share load equally.

Pre-adjustment of the preload during manufacture eliminates the need to measure bearing face steps and to produce custom made spacers of differing widths to achieve the required preload.

Matching

Super precision angular contact ball bearings are supplied singly, in pairs and in multiple sets with matched bores and outside diameters. Matching improves load sharing when bearings are mounted close together.

The size variation of the bore and outside diameters of sets of bearings is generally $\frac{1}{3}$ rd of the tolerance. The bore and outside diameters of all bearings within a set will be within the specified size deviation tolerance, but will not necessarily be the same as each other.

Super precision bearings are graded (**fig. 3a**) and the deviation in microns from nominal size is marked on the face of each ring (**fig. 3b**). The grades are also marked next to the designation on the end of the box (**fig. 3c**).

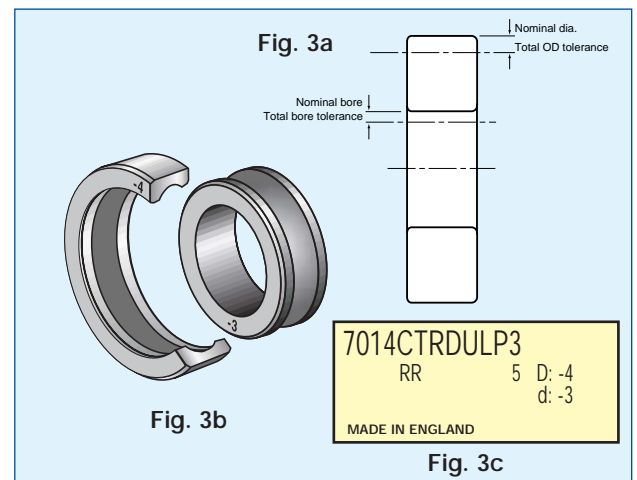

Sets of Bearings

For heavily loaded applications, or where greater rigidity is required, it may be necessary to use a multiple bearing set. The composition of the set can be varied according to the loads to be imposed.

In certain cases specific configurations may be required as shown in **fig. 4**. Due to the special matching a 'V' line is included on the outside diameter of the bearings to ensure that they are mounted in the correct order. As standard the 'V' points in the direction of maximum axial capacity when the load is applied to the inner ring. The order of the bearings must not be changed, nor must they be interchanged between sets.

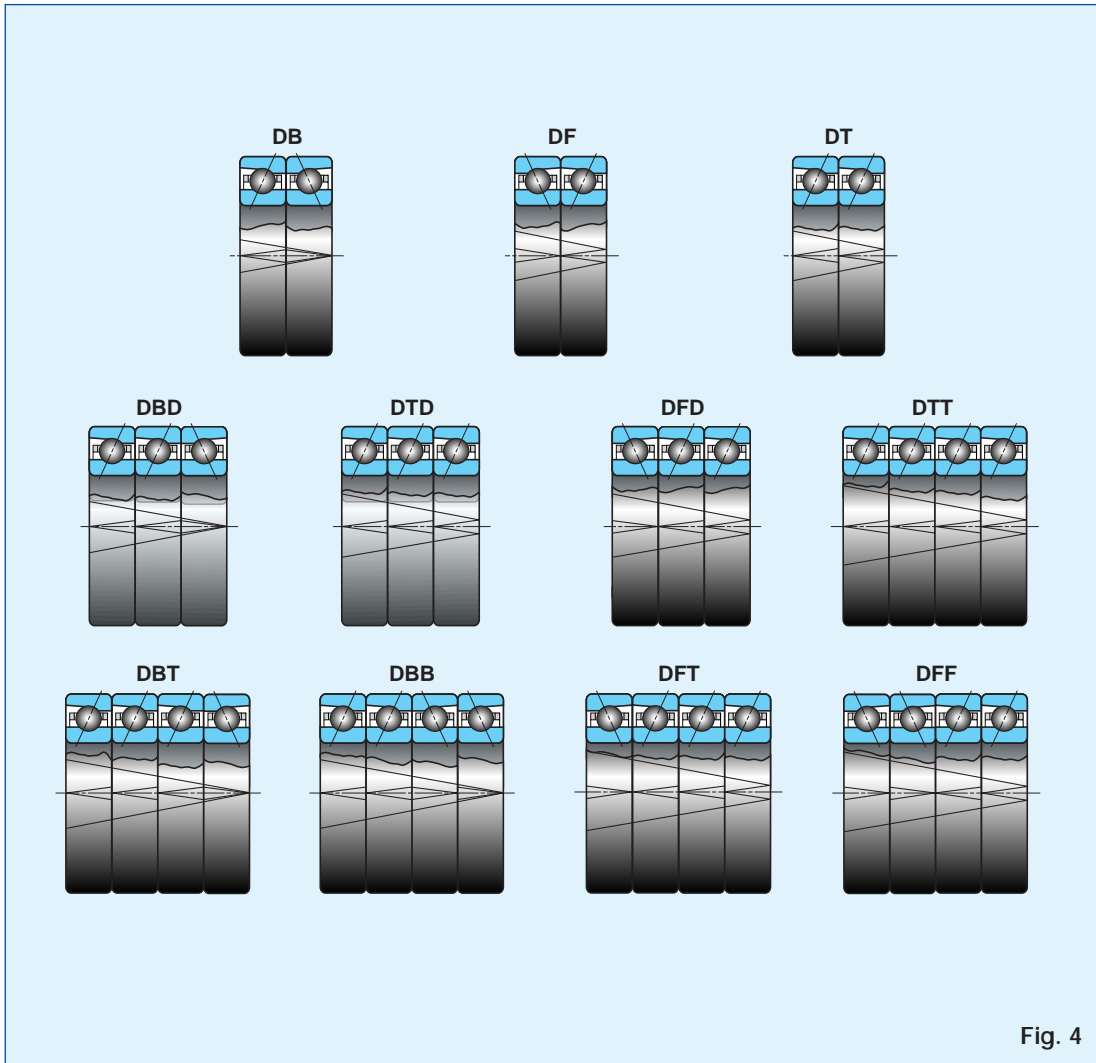

Fig. 4

Limiting Speeds

Limiting speeds are listed in the bearing tables. They should be regarded as a guide rather than an absolute figure since maximum speed can be affected by a variety of circumstances. They apply on condition that the bearings are operating under normal temperature conditions, are adequately protected from contamination and that the inner ring is the rotating member.

The tabulated speeds assume a light external load and are for single bearings under a spring preload which is adequate to maintain rolling contact without significant slip or spin between balls and raceways.

Speeds quoted for oil lubrication assume that oil/air lubrication is used and those for grease lubrication assume the use of a premium quality high speed synthetic grease. The use of other types of grease may influence the speed capability. Suggested factors for a selection of greases are shown in **Table 2** overleaf. To obtain the bearing speed multiply the tabulated speed by the appropriate factor.

When bearings are used as back-to-back pairs or sets the recommended limiting speeds are reduced in accordance with **Table 3** overleaf. If the bearings are mounted face-to-face the limiting speeds are reduced by a further 50%. For spring loaded tandem pairs the speed factor is 0,95



Table 2

Grease Type	Factor
Klüber Isoflex NBU15	1,00
Klüber Isoflex Super LDS18	0,83
Klüber Isoflex Topas NB52	0,83
Klüber Isoflex NCA15	0,83

Table 3

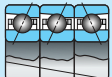
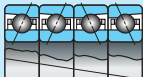
	Pairs DB 	Sets of Three DBD 	Sets of Four DBB 
Extra light	0,85	0,70	0,65
Light	0,80	0,65	0,60
Medium	0,60	0,50	0,45
Heavy	0,40	0,35	0,30

Note: The speed factor for spring loaded tandem pairs is 0,95

Lubrication

A bearing is lubricated for three main reasons:

- (1) to minimise any sliding friction that occurs between raceways, rolling elements and cage,
- (2) to provide corrosion protection for the accurately ground and polished surfaces,
- (3) to dissipate generated heat.

To ensure the successful operation of a spindle assembly, the importance of correct lubrication cannot be over emphasised. Two basic types of lubricant are in general use; oil and grease.

Oil Lubrication

Extremely small amounts of oil are usually enough to lubricate a bearing satisfactorily. Any excess oil increases the drag forces during rotation and energy is dissipated as heat.

As speed increases precise control over the amount of oil is needed. Experience has shown that this is best achieved by an 'oil/air' system in which accurately metered amounts of oil are carried in an airstream and injected into the bearing. The airflow also helps to exclude contaminants from the spindle. The optimum flow may need to be determined experimentally.

A guide to the delivery rate for normal operating speed can be estimated from the following:

$$V = 0,15 \times d \times B \text{ (mm}^3\text{/hour)}$$

A guide to the flow rate for high speed operation is:

$$V = 7 \times 10^{-6} \times B \times D_m \times N \text{ (mm}^3\text{/hour)}$$

Where V = oil flow rate (mm³/ hour)
 d = bearing bore (mm)
 B = bearing width (mm)
 D_m = mean bearing diameter (mm)
 N = maximum spindle speed (rpm)

The delivery can then be increased or decreased until the minimum operating temperature is achieved.

For normal operating speeds nozzles parallel to the spindle axis provide adequate lubrication (fig. 5a). For constant high speed operation nozzles that are angled to the spindle axis have proven advantageous (fig. 5b).

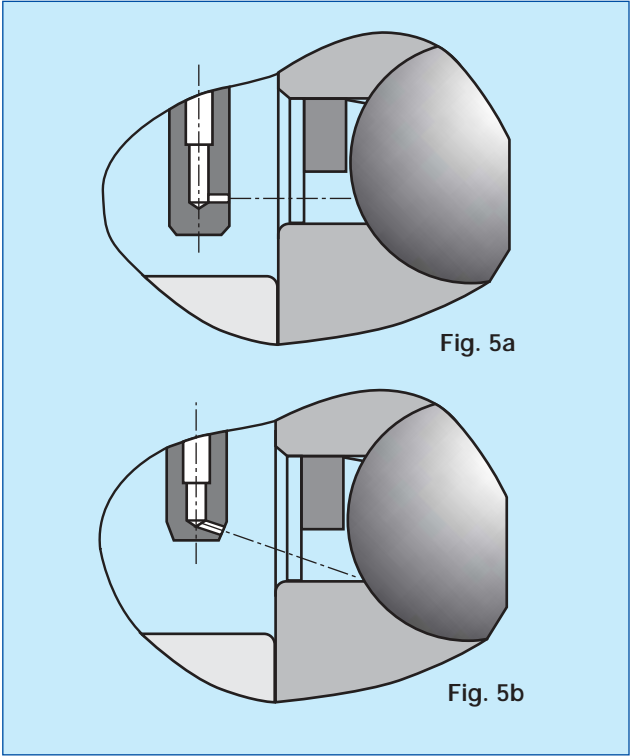

Grease Lubrication

The main advantages of grease lubrication are that it provides an economical method of achieving minimal lubrication and maintenance free operation over long periods. It also eliminates the need for an external lubrication system, permits the use of simple closures and provides some degree of protection against the ingress of contaminants. However, grease lubrication lacks the cooling effect and constant lubrication replenishment provided by oil/air. Consequently bearing speeds with grease lubrication are lower.

The grease type must be selected according to the operating conditions. It has been found that many applications can be satisfied with a selection from the greases in **Table 2**, page 8.

Whichever type of grease is selected, care must be taken in applying the correct quantity and space should be provided to accommodate any excess grease expelled during running.

To use such a nozzle requires more detailed knowledge of the bearing geometry and this can be obtained from NSK.

Adequate drainage must be provided to prevent a build up of oil inside the spindle and around the moving parts which could generate additional heat and cause subsequent bearing failure.

The oil should be filtered before filling the lubricator, the maximum particle size should not exceed 5µm.

Oil Type

A good quality lubricant must be selected to minimise oxidation and foaming. It must be clean and free from moisture to reduce wear. Its viscosity should be just high enough to allow an effective elasto-hydro dynamic (EHD) film to be formed in the pressure zones of the bearing. Lubricant viscosity varies rapidly with temperature and the probable operating temperature should be considered when selecting the type of oil.

Many spindles run over a wide speed range and some compromise may be necessary.

For low and medium speed spindles (<60% of the maximum speed of the bearing set) the recommended grease quantity is 30% of the internal volume, for higher speeds this can be reduced to 20% and for very high speed spindles (>80% of the maximum speed of the bearing set) 10-15% is recommended. Internal volumes are given in the bearing **Tables 8-10** on pages 14-19. If too much grease is packed into the bearing abnormal heat generation occurs causing the grease to deteriorate. To avoid this risk it is necessary to 'run in' spindles for a sufficient time to distribute the grease. It is recommended that the spindle is progressively run up to full speed in a series of suitably sized speed increments whilst monitoring the temperature. The temperature should be allowed to stabilise at each speed increment before increasing the speed. If the temperature reaches 70°C the spindle should be stopped and allowed to cool before restarting it.



AXIAL PRELOAD VALUES FOR PAIRED ANGULAR CONTACT BALL BEARINGS

Table 4

15° CONTACT ANGLE												
Bore Code Reference	79**C SERIES				70**C SERIES				72**C SERIES			
	EL N	L N	M N	H N	EL N	L N	M N	H N	EL N	L N	M N	H N
00					12	25	49	100	14	29	69	150
01					12	25	59	120	19	39	100	200
02					14	29	69	150	19	39	100	200
03	12	25	59	120	14	29	69	150	24	49	150	290
04	19	39	78	150	24	49	120	250	34	69	200	390
05	19	39	100	200	29	59	150	290	39	78	200	390
06	24	49	100	200	39	78	200	390	60	120	290	590
07	34	69	150	290	60	120	250	490	75	150	390	780
08	39	78	200	390	60	120	290	590	100	200	490	980
09	50	100	200	390	75	150	340	690	125	250	540	1 080
10	50	100	250	490	75	150	390	780	125	250	590	1 180
11	60	120	290	590	100	200	490	980	145	290	780	1 570
12	60	120	290	590	100	200	540	1 080	195	390	930	1 860
13	75	150	340	690	125	250	540	1 080	220	440	1 080	2 160
14	100	200	490	980	145	290	740	1 470	245	490	1 180	2 350
15	100	200	490	980	145	290	780	1 570	270	540	1 230	2 450
16	100	200	490	980	195	390	930	1 860	295	590	1 370	2 750
17	145	290	640	1 270	195	390	980	1 960	345	690	1 670	3 330
18	145	290	740	1 470	245	490	1 180	2 350	390	780	1 860	3 730
19	145	290	780	1 570	270	540	1 180	2 350	440	880	2 060	4 120
20	195	390	880	1 770	270	540	1 270	2 550	490	980	2 350	4 710
21	195	390	880	1 770	320	640	1 470	2 940	540	1 080	2 650	5 300
22	195	390	930	1 860	370	740	1 770	3 530	635	1 270	2 940	5 880
24	270	540	1 270	2 550	415	830	1 960	3 920	700	1 400	3 210	6 350
26	320	640	1 470	2 940	490	980	2 260	4 510	760	1 520	3 400	6 740
28	320	640	1 470	2 940	500	1 000	2 210	4 420	925	1 850	4 110	8 300
30	395	790	1 790	3 560	575	1 150	2 560	5 100	1 110	2 220	4 960	9 970
32	425	855	1 930	3 840	625	1 250	2 930	5 840				
34	485	970	2 180	4 310	780	1 560	3 560	7 150				
36	595	1 190	2 650	5 340	930	1 860	4 160	8 320				
38	605	1 210	2 790	5 600	1 030	2 060	4 640	9 340				
40	785	1 570	3 570	7 110	1 150	2 300	5 170	10 350				
44	845	1 680	3 770	7 480								
48	910	1 820	4 120	8 200								
52	1 180	2 360	5 290	10 650								
56	1 320	2 650	6 020	11 970								



AXIAL PRELOAD VALUES FOR PAIRED ANGULAR CONTACT BALL BEARINGS

Table 5

25° CONTACT ANGLE												
Bore Code Reference	79**A5 SERIES				70**A5 SERIES				72**A5 SERIES			
	EL N	L N	M N	H N	EL N	L N	M N	H N	EL N	L N	M N	H N
00					19	39	78	150	19	39	100	200
01					19	39	100	200	29	59	150	290
02					19	39	100	200	34	69	200	390
03	19	39	78	150	24	49	120	250	39	78	200	390
04	29	59	120	250	39	78	200	390	60	120	290	590
05	34	69	150	290	50	100	200	390	75	150	340	690
06	39	78	150	290	60	120	290	590	100	200	440	880
07	50	100	250	490	75	150	390	780	125	250	590	1 180
08	60	120	290	590	100	200	440	880	145	290	740	1 470
09	75	150	340	690	100	200	490	980	170	340	880	1 770
10	75	150	390	780	120	250	590	1 180	195	390	980	1 960
11	100	200	440	880	170	340	780	1 570	245	490	1180	2 350
12	100	200	440	880	170	340	780	1 570	295	590	1 470	2 940
13	100	200	490	980	195	390	880	1 770	345	690	1 670	3 330
14	145	290	690	1 370	245	490	1 080	2 160	390	780	1 860	3 730
15	145	290	740	1 470	245	490	1 180	2 350	415	830	1 960	3 920
16	170	340	780	1 570	320	640	1 470	2 940	465	930	2 160	4 310
17	220	440	980	1 960	320	640	1 470	2 940	540	1 080	2 450	4 900
18	245	490	1 080	2 160	390	780	1 770	3 530	635	1 270	2 940	5 880
19	245	490	1 180	2 350	415	830	1 860	3 730	685	1 370	3 140	6 280
20	295	590	1 270	2 550	415	830	1 960	3 920	785	1 570	3 530	7 060
21	295	590	1 370	2 750	490	980	2 260	4 510	885	1 770	3 920	7 850
22	320	640	1 470	2 940	590	1 180	2 650	5 300	980	1 960	4 410	8 830
24	440	880	1 960	3 920	635	1 270	2 940	5 880	1 140	2 280	5 180	10 350
26	490	980	2 160	4 310	785	1 570	3 430	6 860	1 200	2 410	5 500	11 000
28	490	980	2 260	4 510	785	1 570	3 660	7 270	1 480	2 970	6 650	13 480
30	625	1 250	2 880	5 860	930	1 850	4 070	8 250	1 810	3 620	7 990	16 350
32	665	1 330	3 230	6 290	1 080	2 160	4 700	9 380				
34	775	1 550	3 520	7 110	1 270	2 550	5 900	11 600				
36	1 010	2 020	4 420	8 830	1 550	3 100	6 820	13 560				
38	1 035	2 070	4 550	9 110	1 660	3 320	7 560	15 130				
40	1 280	2 560	5 840	11 620	1 850	3 700	8 360	16 820				
44	1 310	2 620	6 020	11 990								
48	1 430	2 870	6 620	13 220								
52	1 930	3 870	8 700	17 380								
56	2 110	4 220	9 680	19 260								



AXIAL STIFFNESS VALUES FOR PAIRED ANGULAR CONTACT BALL BEARINGS

Table 6

15° CONTACT ANGLE												
Bore Code Reference	79**C SERIES				70**C SERIES				72**C SERIES			
	EL N/μm	L N/μm	M N/μm	H N/μm	EL N/μm	L N/μm	M N/μm	H N/μm	EL N/μm	L N/μm	M N/μm	H N/μm
00					12	17	23	32	13	18	27	38
01					14	18	26	37	16	21	33	46
02					16	20	29	43	17	23	34	48
03	15	20	30	43	16	21	31	45	19	25	42	59
04	19	26	35	48	21	28	42	59	23	30	49	70
05	21	28	43	61	24	32	48	68	26	36	53	76
06	25	33	45	65	29	39	59	83	32	43	66	94
07	29	39	55	78	36	49	68	94	37	50	75	108
08	32	42	63	88	39	51	77	110	44	60	90	126
09	37	50	66	94	43	58	85	121	49	67	94	132
10	39	51	78	111	46	63	96	136	52	69	102	143
11	45	58	90	127	51	69	102	145	56	74	117	163
12	46	60	93	128	53	70	110	158	64	86	126	179
13	53	71	104	146	61	82	117	164	71	95	141	200
14	59	79	119	168	68	88	135	190	75	100	148	210
15	61	79	120	171	70	92	144	202	81	108	157	220
16	62	80	124	173	76	103	152	216	83	109	159	224
17	73	97	138	191	78	106	161	225	88	120	177	251
18	79	102	156	219	87	117	172	242	97	126	187	263
19	81	105	165	231	93	124	176	246	98	130	192	271
20	83	112	164	231	97	127	187	264	101	137	202	285
21	86	116	167	235	103	134	198	277	108	144	216	305
22	89	120	173	244	104	137	203	286	117	156	228	321
24	102	135	200	278	116	153	225	317	128	170	247	345
26	108	148	214	302	126	167	244	344	138	183	262	367
28	111	150	218	309	132	174	248	349	152	202	288	406
30	124	166	239	334	141	187	267	374	167	222	318	447
32	134	179	258	361	147	197	288	403				
34	151	200	288	403	160	213	309	435				
36	158	211	302	425	179	238	342	479				
38	162	217	315	443	188	251	360	507				
40	183	244	352	493	198	264	379	533				
44	193	256	368	515								
48	211	281	405	568								
52	215	286	410	577								
56	242	322	461	648								



AXIAL STIFFNESS VALUES FOR PAIRED ANGULAR CONTACT BALL BEARINGS

Table 7

25° CONTACT ANGLE												
Bore Code Reference	79**A5 SERIES				70**A5 SERIES				72**A5 SERIES			
	EL N/μm	L N/μm	M N/μm	H N/μm	EL N/μm	L N/μm	M N/μm	H N/μm	EL N/μm	L N/μm	M N/μm	H N/μm
00					29	41	51	67	29	41	58	73
01					31	45	60	81	36	49	70	92
02					33	43	65	84	43	57	83	111
03	34	46	62	81	41	52	75	99	46	60	87	116
04	43	60	75	103	51	68	97	128	59	73	104	140
05	56	70	95	123	61	79	99	133	68	90	124	167
06	61	77	99	131	68	89	129	171	85	107	147	192
07	70	94	127	170	78	107	149	198	95	118	167	218
08	72	97	139	182	95	127	168	223	104	136	195	258
09	87	114	160	207	99	132	181	238	115	147	212	280
10	94	124	175	235	118	154	208	278	129	163	233	306
11	112	144	198	263	127	170	235	307	141	181	255	337
12	117	150	198	267	134	179	241	317	155	202	281	374
13	125	161	223	289	157	196	272	356	177	221	314	414
14	138	183	249	334	170	218	293	390	188	238	331	438
15	142	188	267	347	179	229	316	418	199	253	352	466
16	156	203	274	367	187	245	343	448	200	258	356	472
17	172	229	306	402	196	257	352	462	217	283	383	507
18	188	253	340	449	218	275	374	494	239	304	416	556
19	195	262	363	475	227	287	392	525	240	308	419	557
20	197	266	346	463	235	299	417	548	251	325	441	587
21	203	264	368	490	246	317	430	571	267	348	471	624
22	222	284	391	517	258	330	447	588	280	368	496	660
24	244	328	441	580	281	361	491	654	315	409	559	739
26	262	346	460	611	305	396	536	710	334	435	595	788
28	273	348	479	635	317	413	569	750	373	481	654	870
30	308	393	540	719	351	446	601	800	416	532	719	960
32	330	422	592	775	376	482	649	858				
34	376	478	653	867	401	514	707	929				
36	397	514	693	917	450	577	779	1 028				
38	409	531	717	949	460	599	819	1 084				
40	453	585	801	1 057	493	631	860	1 141				
44	466	604	828	1 095								
48	513	666	914	1 210								
52	530	687	937	1 238								
56	591	767	1 047	1 384								



79**

ISO SERIES 19

Single Row Angular Contact Ball Bearings

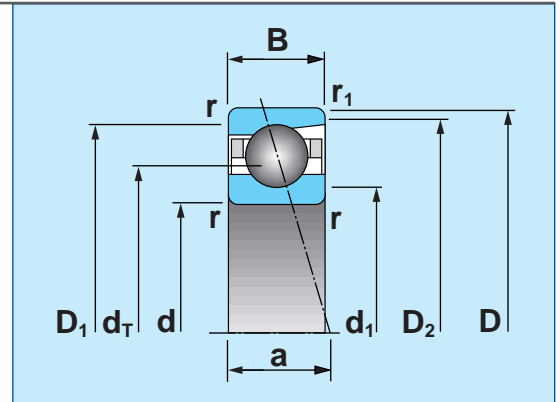

Basic Bearing	Primary dimensions					Limiting speeds		Load ratings		Abutment dimensions			Effective load centre a	Internal volume cm ³	PCD of lubrication jets d _T (DIN 628-6)	Mass Kg
	d	D	B	r min	r ₁ min	oil/air	grease	dynamic C _r	static C _{or}	d ₁ min	D ₁ max	D ₂ max				
	mm					rev/min		N		mm						
7903CTRSU 7903A5TRSU	17	30	7	0,3	0,15	71 400	44 200	5 000	2 940	19,5	27,5	28,8	6,6 9,0	0,9	21,8	0,016
7904CTRSU 7904A5TRSU	20	37	9	0,3	0,15	58 800	36 400	6 950	4 250	22,5	34,5	35,8	8,3 11,1	1,8	26,1	0,037
7905CTRSU 7905A5TRSU	25	42	9	0,3	0,15	50 700	31 400	7 850	5 400	27,5	39,5	40,8	9,0 12,3	2,0	31,1	0,042
7906CTRSU 7906A5TRSU	30	47	9	0,3	0,15	45 200	27 900	8 300	6 250	32,5	44,5	45,8	9,7 13,5	2,3	36,1	0,049
7907CTRSU 7907A5TRSU	35	55	10	0,6	0,3	39 900	24 700	12 100	9 150	40	50	52,5	11,0 15,5	3,6	42,6	0,074
7908CTRSU 7908A5TRSU	40	62	12	0,6	0,3	36 000	22 300	15 100	11 700	45	57	59,5	12,8 17,9	5,6	47,9	0,108
7909CTRSU 7909A5TRSU	45	68	12	0,6	0,3	32 400	20 000	16 000	13 400	50	63	65,5	13,6 19,2	6,2	53,4	0,128
7910CTRSU 7910A5TRSU	50	72	12	0,6	0,3	31 100	18 600	16 900	15 000	55	67	69,5	14,2 20,2	6,7	57,9	0,129
7911CTRSU 7911A5TRSU	55	80	13	1,0	0,6	26 900	16 600	19 100	17 700	61	74	75	15,5 22,2	8,5	64,0	0,179
7912CTRSU 7912A5TRSU	60	85	13	1,0	0,6	24 900	15 400	19 400	18 700	66	79	80	16,2 23,4	9,3	69,0	0,191
7913CTRSU 7913A5TRSU	65	90	13	1,0	0,6	23 000	14 200	20 200	20 500	71	84	85	16,9 24,6	9,9	74,0	0,205
7914CTRSU 7914A5TRSU	70	100	16	1,0	0,6	20 700	12 800	28 100	27 800	76	94	95	19,4 27,8	16,1	80,9	0,335
7915CTRSU 7915A5TRSU	75	105	16	1,0	0,6	19 300	11 900	28 600	29 300	81	99	100	20,1 29,0	17,1	85,5	0,354
7916CTRSU 7916A5TRSU	80	110	16	1,0	0,6	18 100	11 100	29 000	30 500	86	104	105	20,7 30,2	18,2	90,5	0,372
7917CTRSU 7917A5TRSU	85	120	18	1,1	0,6	16 500	10 200	39 000	40 500	92	113	115	22,7 32,9	24,7	98,8	0,533
7918CTRSU 7918A5TRSU	90	125	18	1,5	0,6	15 400	9 500	41 500	46 000	97	118	120	23,4 34,1	25,6	102,8	0,559
7919CTRSU 7919A5TRSU	95	130	18	1,5	0,6	14 400	9 000	42 500	48 000	102	123	125	24,1 35,2	26,9	107,7	0,584



79**

ISO SERIES 19

Single Row Angular Contact Ball Bearings

Table 8

Basic Bearing	Primary dimensions					Limiting speeds		Load ratings		Abutment dimensions			Effective load centre a	Internal volume cm ³	PCD of lubrication jets d _r (DIN 628-6)	Mass Kg
	d	D	B	r min	r ₁ min	oil/air	grease	dynamic C _r	static C _{0r}	d ₁ min	D ₁ max	D ₂ max				
	mm					rev/min		N		mm			mm	mm		
7920CTRSU 7920A5TRSU	100	140	20	1,5	0,6	14 000 12 300	8 500 8 000	50 000 47 500	54 000 51 500	107	133	135	26,1 38,0	36,3	116,0	0,786
7921CTRSU 7921A5TRSU	105	145	20	1,5	0,6	13 400 11 800	8 200 7 700	51 000 48 000	57 000 54 000	112	138	140	26,7 39,2	37,8	119,5	0,819
7922CTRSU 7922A5TRSU	110	150	20	1,5	0,6	12 900 11 300	7 900 7 400	52 000 49 000	59 500 56 000	117	143	145	27,4 40,3	39,3	124,5	0,851
7924CTRSU 7924A5TRSU	120	165	22	1,5	0,6	11 800 10 300	7 600 6 700	72 000 67 500	81 000 77 000	127	158	160	30,1 44,2	55,1	136,3	1,149
7926CTRSU 7926A5TRSU	130	180	24	2,0	1,0	10 800 9 500	7 000 6 200	78 500 74 000	91 000 86 000	139	171	174	32,8 48,1	69,8	149,3	1,524
7928CTRSU 7928A5TRSU	140	190	24	2,0	1,0	10 200 8 900	6 500 5 800	79 500 75 000	95 500 90 000	149	181	184	34,1 50,5	74,8	158,1	1,618
7930CTRSU 7930A5TRSU	150	210	28	2,5	1,0	9 300 8 200	6 000 5 300	102 000 96 500	122 000 115 000	160	200	204	38,1 56,0	108,2	171,8	2,515
7932CTRSU 7932A5TRSU	160	220	28	2,5	1,0	8 800 7 800	5 700 5 100	106 000 100 000	133 000 125 000	170	210	214	39,4 58,3	113,3	181,8	2,668
7934CTRSU 7934A5TRSU	170	230	28	2,5	1,0	8 400 7 400	5 400 4 800	113 000 106 000	148 000 140 000	180	220	224	40,8 60,6	117,0	191,8	2,841
7936CTRSU 7936A5TRSU	180	250	33	2,5	1,0	7 800 6 800	5 000 4 500	145 000 137 000	184 000 174 000	190	240	244	45,3 66,6	173,7	205,6	4,196
7938CTRSU 7938A5TRSU	190	260	33	2,5	1,0	7 500 6 500	4 800 4 300	147 000 139 000	192 000 182 000	200	250	254	46,6 69,0	183,2	215,4	4,383
7940CTRSU 7940A5TRSU	200	280	38	2,5	1,5	7 000 6 100	4 500 4 000	189 000 178 000	244 000 231 000	212	268	273	51,2 75,0	252,1	229,0	6,210
7944CTRSU 7944A5TRSU	220	300	38	2,5	1,5	6 500 5 700	4 200 3 700	190 000 179 000	256 000 242 000	232	288	293	53,8 79,6	278,0	249,0	6,665
7948CTRSU 7948A5TRSU	240	320	38	2,5	1,5	6 000 5 300	3 900 3 400	200 000 189 000	286 000 270 000	252	308	313	56,5 84,3	296,1	271,4	7,224
7952CTRSU 7952A5TRSU	260	360	46	2,5	1,5	5 500 4 700	3 500 3 100	256 000 241 000	365 000 345 000	272	348	353	64,5 95,3	511,5	299,2*	11,936
7956CTRSU 7956A5TRSU	280	380	46	2,5	1,5	5 000 4 400	3 300 2 900	272 000 256 000	410 000 390 000	292	368	373	67,2 99,9	533,9	319,2*	12,853

* Not specified in DIN 628-6: 1999-07



70**

ISO SERIES 10

Single Row Angular Contact Ball Bearings

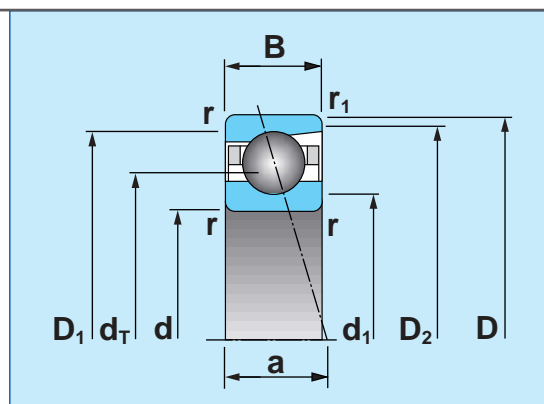

Basic Bearing	Primary dimensions					Limiting speeds		Load ratings		Abutment dimensions			Effective load centre a	Internal volume cm ³	PCD of lubrication jets d _T (DIN 628-6)	Mass Kg
	d	D	B	r min	r ₁ min	oil/air	grease	dynamic C _r	static C _{or}	d ₁ min	D ₁ max	D ₂ max				
mm					rev/min		N		mm			mm	mm	Kg		
7000CTRSU 7000A5TRSU	10	26	8	0,3	0,15	92 400	57 000	5 300	2 490	12,5	23,5	24,8	6,4 8,2	0,9	16,1	0,019
7001CTRSU 7001A5TRSU	12	28	8	0,3	0,15	84 000	52 000	5 800	2 900	14,5	25,5	26,8	6,7 8,7	1,0	18,3	0,020
7002CTRSU 7002A5TRSU	15	32	9	0,3	0,15	71 400	44 200	6 250	3 400	17,5	29,5	30,8	7,6 10,0	1,4	21,3	0,031
7003CTRSU 7003A5TRSU	17	35	10	0,3	0,15	64 100	39 600	6 600	3 800	19,5	32,5	33,8	8,5 11,1	1,9	23,5	0,040
7004CTRSU 7004A5TRSU	20	42	12	0,6	0,3	53 600	33 100	11 100	6 550	25	37	39,5	10,1 13,2	3,1	28,2	0,069
7005CTRSU 7005A5TRSU	25	47	12	0,6	0,3	47 500	29 300	11 700	7 400	30	42	44,5	10,8 14,4	3,8	32,9	0,079
7006CTRSU 7006A5TRSU	30	55	13	1,0	0,6	42 000	26 000	15 100	10 300	36	49	50	12,2 16,4	5,3	39,5	0,114
7007CTRSU 7007A5TRSU	35	62	14	1,0	0,6	37 600	23 200	19 100	13 700	41	56	57	13,5 18,3	7,0	44,6	0,150
7008CTRSU 7008A5TRSU	40	68	15	1,0	0,6	34 000	21 000	20 600	15 900	46	62	63	14,7 20,1	8,2	50,0	0,189
7009CTRSU 7009A5TRSU	45	75	16	1,0	0,6	30 500	18 800	24 400	19 300	51	69	70	16,0 22,0	11,2	55,6	0,238
7010CTRSU 7010A5TRSU	50	80	16	1,0	0,6	28 000	17 300	26 000	21 900	56	74	75	16,7 23,2	12,0	60,6	0,259
7011CTRSU 7011A5TRSU	55	90	18	1,1	0,6	25 000	15 400	34 000	28 600	62	83	85	18,7 25,9	16,9	67,3	0,375
7012CTRSU 7012A5TRSU	60	95	18	1,1	0,6	23 000	14 200	35 000	30 500	67	88	90	19,4 27,1	18,0	72,5	0,407
7013CTRSU 7013A5TRSU	65	100	18	1,1	0,6	21 600	13 300	37 000	34 500	72	93	95	20,0 28,2	19,0	77,5	0,435
7014CTRSU 7014A5TRSU	70	110	20	1,1	0,6	19 300	11 900	47 000	43 000	77	103	105	22,1 31,0	26,3	83,7	0,606
7015CTRSU 7015A5TRSU	75	115	20	1,1	0,6	18 100	11 100	48 000	45 500	82	108	110	22,7 32,1	27,8	89,4	0,639



70**

ISO SERIES 10

Single Row Angular Contact Ball Bearings

Table 9

Basic Bearing	Primary dimensions					Limiting speeds		Load ratings		Abutment dimensions			Effective load centre a	Internal volume cm ³	PCD of lubrication jets d _r (DIN 628-6)	Mass Kg
	d	D	B	r min	r ₁ min	oil/air	grease	dynamic C _r	static C _{or}	d ₁ min	D ₁ max	D ₂ max				
	mm					rev/min		N		mm						
7016CTRSU 7016A5TRSU	80	125	22	1,5	0,6	16 500 14 300	10 200 9 200	58 500 55 500	55 500 52 500	87	118	120	24,7 34,9	36,4	96,5	0,851
7017CTRSU 7017A5TRSU	85	130	22	1,5	0,6	15 600 13 700	9 500 8 800	60 000 57 000	58 500 55 500	92	123	125	25,4 36,1	38,2	101,5	0,894
7018CTRSU 7018A5TRSU	90	140	24	1,5	1,0	14 600 12 800	8 700 8 200	71 500 68 000	69 000 65 500	99	131	134	27,4 38,8	49,3	108,6	1,161
7019CTRSU 7019A5TRSU	95	145	24	1,5	1,0	14 000 12 200	8 600 7 900	73 500 69 500	73 000 69 500	104	136	139	28,1 40,0	51,8	113,3	1,211
7020CTRSU 7020A5TRSU	100	150	24	1,5	1,0	13 400 11 800	8 400 7 600	75 500 71 000	77 000 73 500	109	141	144	28,7 41,1	53,4	118,6	1,264
7021CTRSU 7021A5TRSU	105	160	26	2,5	1,0	12 700 11 100	8 200 7 200	88 000 83 500	89 500 85 000	115	150	154	30,7 43,9	68,0	125,1	1,574
7022CTRSU 7022A5TRSU	110	170	28	2,5	1,0	12 000 10 500	7 700 6 900	106 000 100 000	104 000 99 000	120	160	164	32,7 46,6	88,3	131,9	1,927
7024CTRSU 7024A5TRSU	120	180	28	2,5	1,0	11 200 9 800	7 200 6 400	112 000 106 000	117 000 111 000	130	170	174	34,1 49,0	93,5	142,3	2,082
7026CTRSU 7026A5TRSU	130	200	33	2,5	1,0	10 200 8 900	6 500 5 800	129 000 122 000	137 000 130 000	140	190	194	38,6 55,0	131,8	156,2	3,229
7028CTRSU 7028A5TRSU	140	210	33	2,5	1,0	9 600 8 400	6 200 5 500	132 000 125 000	145 000 138 000	150	200	204	39,9 57,3	141,0	165,7	3,414
7030CTRSU 7030A5TRSU	150	225	35	2,5	1,5	8 900 7 900	5 800 5 100	151 000 143 000	168 000 160 000	162	213	218	42,6 61,2	171,2	178,1	4,164
7032CTRSU 7032A5TRSU	160	240	38	2,5	1,5	8 400 7 400	5 400 4 800	171 000 162 000	193 000 183 000	172	228	233	45,8 65,6	210,8	190,4	5,146
7034CTRSU 7034A5TRSU	170	260	42	2,5	1,5	7 800 6 800	5 000 4 500	205 000 193 000	234 000 223 000	182	248	253	49,8 71,1	281,3	203,4	6,905
7036CTRSU 7036A5TRSU	180	280	46	2,5	1,5	7 400 6 400	4 700 4 200	228 000 216 000	276 000 262 000	192	268	273	53,8 76,6	346,4	217,1	9,219
7038CTRSU 7038A5TRSU	190	290	46	2,5	1,5	7 000 6 100	4 500 4 000	247 000 233 000	305 000 291 000	202	278	283	55,2 79,0	363,7	227,1	9,444
7040CTRSU 7040A5TRSU	200	310	51	2,5	1,5	6 600 5 800	4 200 3 800	265 000 250 000	340 000 325 000	212	298	303	59,7 85,0	470,8	240,9	12,452



72**

ISO SERIES 02

Single Row Angular Contact Ball Bearings

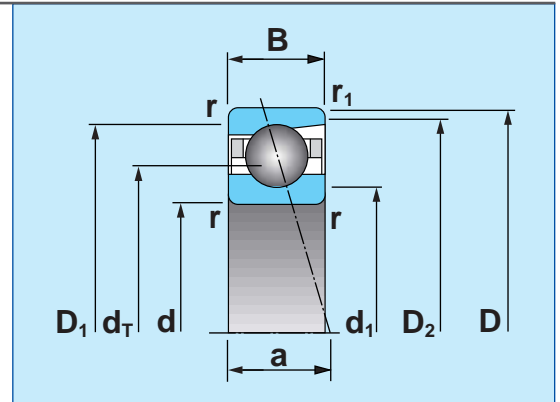

Basic Bearing	Primary dimensions					Limiting speeds		Load ratings		Abutment dimensions			Effective load centre a	Internal volume cm ³	PCD of lubrication jets d _T *	Mass Kg
	d	D	B	r min	r ₁ min	oil/air	grease	dynamic C _r	static C _{0r}	d ₁ min	D ₁ max	D ₂ max				
	mm					rev/min		N		mm						
7200CTRSU 7200A5TRSU	10	30	9	0,6	0,3	84 000	52 000	5 400	2 610	15	25	27,5	7,2 9,2	1,2	18,1	0,032
7201CTRSU 7201A5TRSU	12	32	10	0,6	0,3	76 100	47 000	7 900	3 850	17	27	29,5	7,9 10,1	1,7	19,6	0,036
7202CTRSU 7202A5TRSU	15	35	11	0,6	0,3	67 200	41 600	8 650	4 550	20	30	32,5	8,8 11,3	2,2	22,6	0,045
7203CTRSU 7203A5TRSU	17	40	12	0,6	0,3	58 800	36 400	10 900	5 850	22	35	37,5	9,8 12,6	3,1	25,9	0,065
7204CTRSU 7204A5TRSU	20	47	14	1,0	0,6	50 700	31 300	14 600	8 050	26	41	42	11,5 14,8	4,7	30,5	0,104
7205CTRSU 7205A5TRSU	25	52	15	1,0	0,6	44 900	27 800	16 600	10 200	31	46	47	12,7 16,5	6,2	35,5	0,128
7206CTRSU 7206A5TRSU	30	62	16	1,0	0,6	39 200	24 200	23 000	14 700	36	56	57	14,2 18,7	8,8	42,4	0,194
7207CTRSU 7207A5TRSU	35	72	17	1,1	0,6	34 300	21 200	30 500	19 900	42	65	67	15,7 21,0	12,4	49,2	0,281
7208CTRSU 7208A5TRSU	40	80	18	1,1	0,6	30 600	18 900	36 500	25 200	47	73	75	17,0 23,0	15,5	55,5	0,366
7209CTRSU 7209A5TRSU	45	85	19	1,1	0,6	28 000	17 300	41 000	28 800	52	78	80	18,2 24,7	18,8	60,2	0,407
7210CTRSU 7210A5TRSU	50	90	20	1,1	0,6	25 400	15 700	43 000	31 500	57	83	85	19,4 26,3	21,7	65,2	0,457
7211CTRSU 7211A5TRSU	55	100	21	1,5	1,0	23 000	14 200	53 000	40 000	64	91	94	20,9 28,6	27,8	72,0	0,603
7212CTRSU 7212A5TRSU	60	110	22	1,5	1,0	20 700	12 800	64 000	49 000	69	101	104	22,4 30,8	35,1	79,0	0,779
7213CTRSU 7213A5TRSU	65	120	23	1,5	1,0	18 700	11 500	73 000	58 500	74	111	114	23,9 33,1	41,1	86,2	1,007

*Not specified in DIN 628-6: 1999-07



72**

ISO SERIES 02

Single Row Angular Contact Ball Bearings

Table 10

Basic Bearing	Primary dimensions					Limiting speeds		Load ratings		Abutment dimensions			Effective load centre a	Internal volume cm ³	PCD of lubrication jets d _l * mm	Mass Kg
	d	D	B	r min	r ₁ min	oil/air	grease	dynamic C _r	static C _{0r}	d ₁ min	D ₁ max	D ₂ max				
	mm					rev/min		N		mm						
7214CTRSU 7214A5TRSU	70	125	24	1,5	1,0	17 500 15 000	10 800 9 900	79 500 76 000	64 500 61 500	79	116	119	25,1 34,7	47,5	90,9	1,085
7215CTRSU 7215A5TRSU	75	130	25	1,5	1,0	16 400 14 300	10 100 9 400	83 000 79 000	70 000 66 500	84	121	124	26,2 36,4	51,5	95,9	1,186
7216CTRSU 7216A5TRSU	80	140	26	2,5	1,0	15 200 13 300	9 200 8 700	93 000 88 500	77 500 74 000	90	130	134	27,7 38,6	63,7	102,8	1,419
7217CTRSU 7217A5TRSU	85	150	28	2,5	1,0	14 300 12 500	8 500 8 100	107 000 102 000	90 500 86 500	95	140	144	29,7 41,4	78,5	109,8	1,782
7218CTRSU 7218A5TRSU	90	160	30	2,5	1,0	13 400 11 800	7 800 7 500	123 000 117 000	105 000 100 000	100	150	154	31,7 44,1	95,1	116,7	2,206
7219CTRSU 7219A5TRSU	95	170	32	2,5	1,5	12 700 11 100	7 600 7 200	133 000 127 000	112 000 107 000	107	158	163	33,7 46,9	118,3	123,6	2,634
7220CTRSU 7220A5TRSU	100	180	34	2,5	1,5	12 000 10 500	7 500 6 900	149 000 142 000	127 000 121 000	112	168	173	35,7 49,6	139,2	130,6	3,173
7221CTRSU 7221A5TRSU	105	190	36	2,5	1,5	11 300 10 000	7 300 6 500	162 000 155 000	143 000 137 000	117	178	183	37,7 52,4	165,1	137,4	3,777
7222CTRSU 7222A5TRSU	110	200	38	2,5	1,5	10 800 9 500	7 000 6 200	176 000 168 000	160 000 153 000	122	188	193	39,8 55,1	192,5	144,4	4,453
7224CTRSU 7224A5TRSU	120	215	40	2,5	1,5	10 100 8 800	6 400 5 700	199 000 189 000	192 000 184 000	132	203	208	42,4 59,1	225,7	156,3	5,426
7226CTRSU 7226A5TRSU	130	230	40	3,0	1,5	9 300 8 200	6 000 5 300	207 000 196 000	209 000 199 000	144	216	223	44,1 62,0	244,8	168,9	6,229
7228CTRSU 7228A5TRSU	140	250	42	3,0	1,5	8 600 7 600	5 500 4 900	238 000 226 000	254 000 242 000	154	236	243	47,1 66,5	301,7	182,6	7,899
7230CTRSU 7230A5TRSU	150	270	45	3,0	1,5	8 000 7 000	5 100 4 600	270 000 258 000	305 000 290 000	164	256	263	50,6 71,5	374,6	196,5	10,034

*Not specified in DIN 628-6: 1999-07



Table 11

Accuracy of Associated Components

Super precision ball bearings have relatively thin rings and will take up the shape of the mating shaft or housing, thus transferring any errors in form to the bearing raceway. Abutment faces on the associated parts must be square to the axis of the shaft, or the bearing rings may be misaligned, resulting in increased runout and higher running temperatures, particularly on high speed spindles.

To obtain satisfactory results errors of form should not exceed the values given in **figs. 6 and 7**, and **Tables 11 and 12**.

The housing should be robust so that when it is attached to the machine it is not distorted. When the inner ring is the rotating member, bearings are generally mounted with an interference fit on the shaft. A transition fit should be selected for the housing for locating bearings and a clearance fit selected for sliding bearings.

Recommended shaft and housing tolerances are given in **Tables 13 to 15**.

Permissible errors of form and position of components on machine tool spindles		
	P4	P2 & P3
Δd	IT2	IT1 (IT0)
ΔD	IT3	IT1
ΔS	IT2	IT1
Δe	IT2	IT2

IT = standard ISO tolerance grade

Table 12

0.001mm units										
Nominal diameter of shaft and/or housing (mm)										
over	6	10	18	30	50	80	120	180	250	315
including	10	18	30	50	80	120	180	250	315	400
IT0	0,6	0,8	1	1	1,2	1,5	2	3	4	5
IT1	1	1,2	1,5	1,5	2	2,5	3,5	4,5	6	7
IT2	1,5	2	2,5	2,5	3	4	5	7	8	9
IT3	2,5	3	4	4	5	6	8	10	12	13

IT = standard ISO tolerance grade

Fig. 6

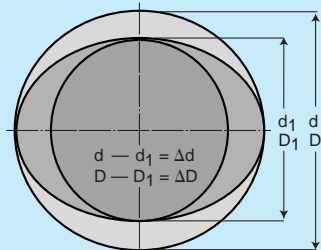

Out of round of shaft or housing

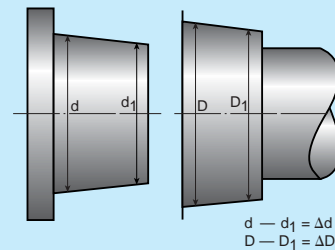

Deviation from cylindrical form of shaft or housing

Fig. 7

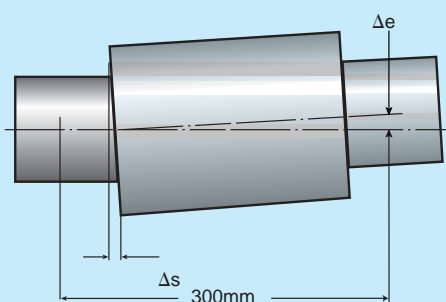

Misalignment of bearing seatings

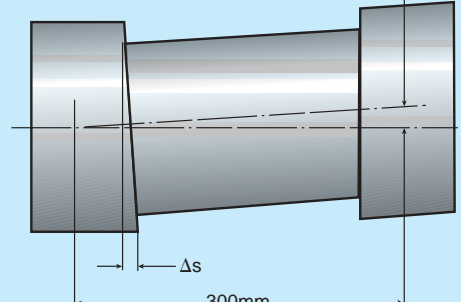

Run-out of abutment faces



Recommended Shaft Tolerances

Table 13

Shaft Limits in μm											
Nominal shaft diameter d (mm)	over including		- 10	10 18	18 30	30 50	50 80	80 120	120 180	180 250	250 315
Shaft limits	P4 & P3	max.	+2	+2	+2	+3	+3	+3	+3,5	+4	+5
		min.	-2	-2	-2	-2	-2	-3	-4	-6	-5
	P2	max.	+0,5	+0,5	+0,5	+0,5	+2	+2	+3	+4	-
		min.	-2	-2	-2	-2	-2	-2	-3	-4	-
Resultant fit	P4 & P3	mean	2T	2T	2T	3T	3T	3T	3,5T	4T	5T
		P2 mean	0,5T	0,5T	0,5T	0,5T	1,9T	3T	3,2T	3,8T	-

T = interference fit

These shaft limits apply when the inner ring rotates and the load line is constant in direction. For other conditions consult NSK.

Tighter shaft fits may be necessary to avoid loosening at speeds over $1.8 \times 10^6 D_m N$, please consult NSK for advice since this will affect the preload.

Recommended Housing Tolerances

Table 14

Housing Limits (Locating Bearings) in μm											
Nominal housing bore D (mm)	over including		18 30	30 50	50 80	80 120	120 150	150 180	180 250	250 315	315 400
Housing limits	P4 & P3	max.	+5	+5	+5	+5	+7	+7	+7	+10	+11
		min.	0	0	0	-2,5	-3	-3	-3	-3	-4
	P2	max.	+4	+4	+4	+5	+5	+5	+5	+5	+7
		min.	0	0	0	0	0	-1	-2,5	-2,5	-4
Resultant fit	P4 & P3	mean	5C	5C	5C	5C	6,5C	7C	7C	10C	10C
		P2 mean	3,9C	3,9C	3,9C	5C	5C	5,2C	5C	5C	6,5C

C = clearance fit

These housing limits apply when the inner ring rotates and the load line is constant in direction. For other conditions consult NSK.

Recommended Housing Tolerances

Table 15

Housing Limits (Sliding Bearings) in μm											
Nominal housing bore D (mm)	over including		18 30	30 50	50 80	80 120	120 150	150 180	180 250	250 315	315 400
Housing limits	P4 & P3	max.	+7	+7	+7	+11	+17	+17	+19	+24	+25
		min.	+2	+2	+2	+3,5	+7	+7	+9	+11	+10
	P2	max.	+7	+8	+9	+11	+13	+13	+15	+17	+21
		min.	+3	+4	+5	+7	+8	+7	+7,5	+9,5	+10
Resultant fit	P4 & P3	mean	7C	7C	7C	11C	16,5C	17C	19C	24C	24C
		P2 mean	6,9C	7,9C	8,9C	11C	13C	13,2C	15C	17C	20,8C

C = clearance fit

These housing limits apply when the inner ring rotates and the load line is constant in direction. For other conditions consult NSK.



Bearing Tolerances

Table 16

Inner Ring Tolerances in μm			0,6	10	18	30	50	80	120	150	180	250
Nominal bore diameter d (mm)	over including		10	18	30	50	80	120	150	180	250	315
Deviation of mean bore diameter Δ_{dmp}	P4 & P3 (+0)	P4 & P3	-4	-4	-4	-5	-5	-6	-7,5	-7,5	-10	-13
		P2	-2,5	-2,5	-2,5	-2,5	-3,8	-5,1	-6,4	-6,4	-7,5	-
Radial runout of an assembled bearing inner ring K_{ia}	P4 P3 P2	P4	2,5	2,5	2,5	4	4	5	6	6	7,5	10
		P3	1,3	1,3	2,5	2,5	2,5	2,5	2,5	5	5	-
		P2	1,3	1,3	2,5	2,5	2,5	2,5	2,5	5	5	-
Reference face runout with bore S_{d}	P4 P3 P2	P4	2,5	2,5	4	4	5	5	6	6	7	10
		P3	1,3	1,3	1,3	1,3	1,3	2,5	2,5	3,8	3,8	-
		P2	1,3	1,3	1,3	1,3	1,3	2,5	2,5	3,8	3,8	-
Raceway groove runout with reference face S_{ia}	P4 P3 P2	P4	2,5	2,5	4	4	4	5	7	7	7,5	10
		P3	1,3	1,3	2,5	2,5	2,5	2,5	2,5	5	5	-
		P2	1,3	1,3	2,5	2,5	2,5	2,5	2,5	5	5	-
Width B-deviations Δ_{Bs}	P4 & P3 (+0)	P4 & P3	-40	-80	-120	-120	-150	-200	-250	-250	-300	-350
		P2	-40	-80	-120	-120	-150	-200	-250	-250	-300	-
Width B-deviations (face adjusted rings) Δ_{Bs}	P4 & P3 (+0)	P4 & P3	-250	-250	-250	-250	-250	-375	-375	-375	-500	-500
		P2	-250	-250	-250	-250	-250	-375	-375	-375	-500	-
Width B-variation of individual ring V_{Bs}	P4 & P3 P2	P4 & P3	2,5	2,5	2,5	2,5	4	4	5	5	5	7,5
		P2	1,3	1,3	1,3	1,3	1,3	2,5	2,5	4	4	-

Table 17

Outer Ring Tolerances in μm			18	30	50	80	120	150	180	250	315
Nominal outside diameter D (mm)	over including		30	50	80	120	150	180	250	315	400
Deviation of mean outside diameter Δ_{Dmp}	P4 & P3 (+0)	P4 & P3	-5	-5	-5	-7,5	-9	-10	-10	-13	-13
		P2	-3,8	-3,8	-3,8	-5	-5	-6,4	-7,5	-7,5	-10
Radial runout of an assembled bearing outer ring K_{ea}	P4 P3 P2	P4	4	5	5	5	7	7,5	10	10	13
		P3	2,5	2,5	3,8	5	5	5	6,4	6,4	7,5
		P2	2,5	2,5	3,8	5	5	5	6,4	6,4	7,5
Outer diameter runout with reference face S_{D}	P4 P3 P2	P4	4	4	4	5	5	5	7	7,5	10
		P3	1,3	1,3	1,3	2,5	2,5	2,5	3,8	3,8	6
		P2	1,3	1,3	1,3	2,5	2,5	2,5	3,8	3,8	6
Raceway groove runout with reference face S_{ea}	P4 P3 P2	P4	5	5	5	5	7	7,5	10	10	13
		P3	2,5	2,5	3,8	5	5	5	6,4	6,4	7,5
		P2	2,5	2,5	3,8	5	5	5	6,4	6,4	7,5

The width deviation (Δ_{Cs}) and width variation (V_{Cs}) for an outer ring is the same as that of the inner ring (Δ_{Bs} and V_{Bs}) of the same bearing.



RHP Super Precision Angular Contact Ball Bearings

7 0 10 C TR DU L P3

7	TYPE	7	Single row angular contact ball bearing		
0	DIMENSION SERIES	RHP 9 0 2	ISO 19 10 02		
10	BORE CODE	00 - 10mm 01 - 12mm 04 upwards multiply by 5 to obtain bore size in mm	02 - 15mm 03 - 17mm		
C	CONTACT ANGLE	C A5	15° 25°		
	CONSTRUCTION¹	● SN24	Normal type (steel ball) Ceramic ball type		
TR	CAGE MATERIAL & LOCATION	TR	Outer ring guided phenolic cage		
DU	GROUPING	SU DU, DB, DF, DT 3U, DBD, DFD, DTD QU, DBB, DFF, DBT, DFT	Single universal Paired unit Triple set Quad set		
L	PRELOAD	EL L M H	Extra light Light Medium Heavy	P**, CP** A**, CA**	Special preload Special axial clearance
P3	PRECISION GRADE	RHP P4 P3 P2	ISO Class 4 Dimensional accuracy P4, running accuracy P2 Class 2	ABEC 7 9	

- Denotes standard feature, no indicator necessary
- ** Denotes mean figure given in μm
- Denotes possible reference indicator may appear
- ¹ In the old RHP design, construction is before the contact angle

Super Precision Sealed Angular Contact Ball Bearings

Five reasons to up-grade to sealed angular contact bearings

- Time saving for the end user, no grease fill operation
- Reduce down time, eliminate contamination through poor handling
- Improved spindle performance
- Higher accuracy due to reduced contamination
- Longer grease life



1 Time saving to end user, no grease fill operation Bearings pre-greased by NSK



- NSK high-speed and high performance grease used throughout range.

Ensures

- Correct grease is used
 - Correct grease quantity is used
 - The grease is put in the correct position
 - Contamination does not enter the bearing during the greasing process
 - The grease is in date
- Saves the end user valuable time by eliminating an extra process.

These benefits ensure the bearing is in the best possible condition and optimum performance can be achieved.

2 Reduced down time Eliminate contamination though poor handling



When an unsealed bearing is removed from its protective box and plastic bag it is open to differing environments. In a Class One clean room this would not be a concern, however most workshops are a long way from this ideal.



Grease in an unsealed bearing can attract dirt and dust, both hard and soft fibres. If hard particles get into the bearing, the grease will use them as a grinding paste. This would result in:

During the period of taking an ultra clean precision bearing from its original packaging to the machine mounting there are many opportunities for external contamination for ingress.

- Sealed bearings prevent contamination entering the bearing from hands and equipment
- Sealed bearings prevent debris being transferred from the fitting table to the bearing
- Sealed bearings can prevent down time and warranty claims due to premature failure

- Raceway wear
- Ball surface wear
- Noise, vibration
- Breakdown of lubricant
- Inaccuracies of product produced
- Premature failure

These benefits ensure that the bearings are in the best possible condition with no contamination present before use in the application.

3 Better Spindle performance Prevents grease migration in vertical spindles

The majority of machining centres use spindles in the vertical orientation and more recent trends show that 5-axis machines can perform with the spindle in many positions, from horizontal to vertical. This movement of the spindle and working in the vertical position can cause the grease to drop/slump from one bearing to the next. This can increase the temperature of some bearings and possibly starve others of lubricant.

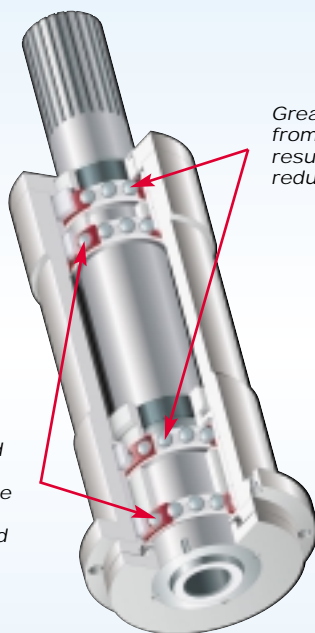
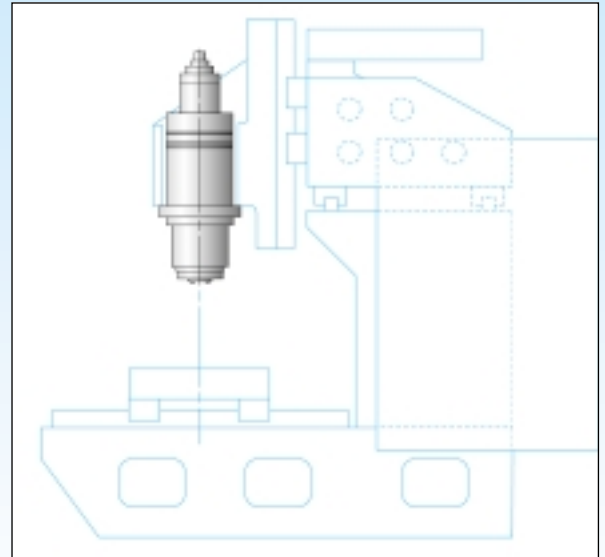

Grease can drop from the bearings resulting in reduced life

Grease is added to the bearings causing increase in bearing temperature and preload and possible failure

The use of sealed bearings prevents grease migrating from the upper to lower bearings

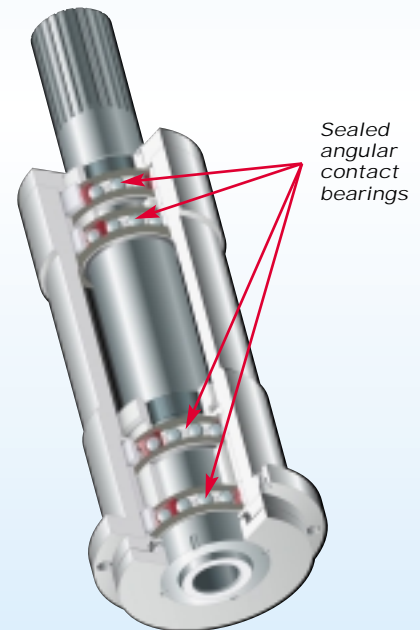

Sealed angular contact bearings

No speed compromise

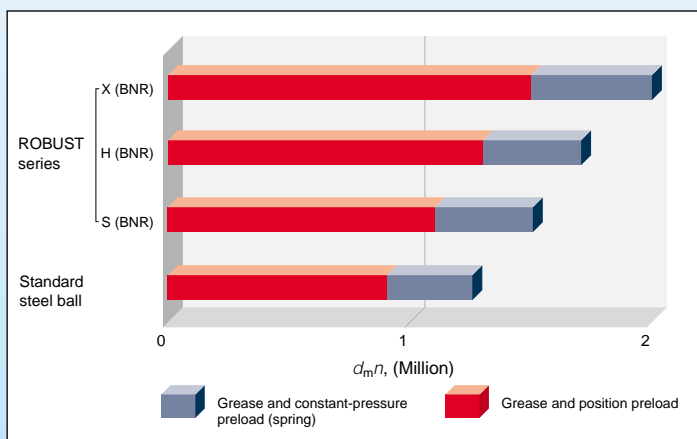

- Sealed bearings in operation prevent starvation of some bearings and temperature rises in others
- They allow the spindle to run at a stable temperature whatever its orientation
- Better machining accuracies can be achieved due to less temperature variation

These benefits ensure the best possible machining performance in the application.

4 Higher accuracy due to reduced contamination Prevents entry of contaminants in operation



While a non-contacting seal cannot always prevent the ingress of water it can prevent the ingress of solid contaminants that could enter the spindle either from the work end (cutting end) or from the rear end.

Labyrinth seals usually offer less protection to the rear end of the spindle and debris from drive belt material can sometimes enter. The use of sealed bearings gives extra protection.

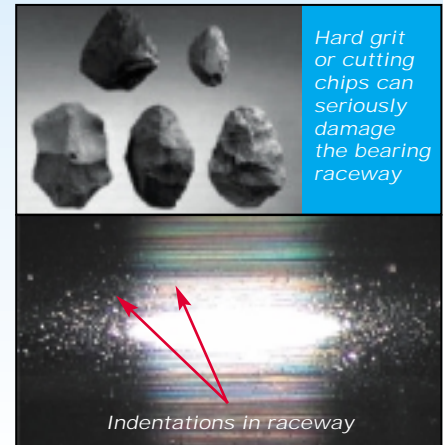

Hard grit or cutting chips can seriously damage the bearing raceway

Indentations in raceway

- Sealed bearings prevent the entry of most contamination both before and after machine build and also during operation
- Used in combination with existing external sealing arrangements, sealed bearings provide maximum protection
- The elimination of external contamination prevents noise and vibration.

5 Longer grease life Seals prevent loss of grease and reduce ageing

Tests have shown that the use of sealed bearings as a replacement for open bearings have resulted in an increase grease life of up to 50%. This is because the grease is maintained in the optimum position, reducing grease loss and the reduction of airflow that can cause drying of a greased open bearing.

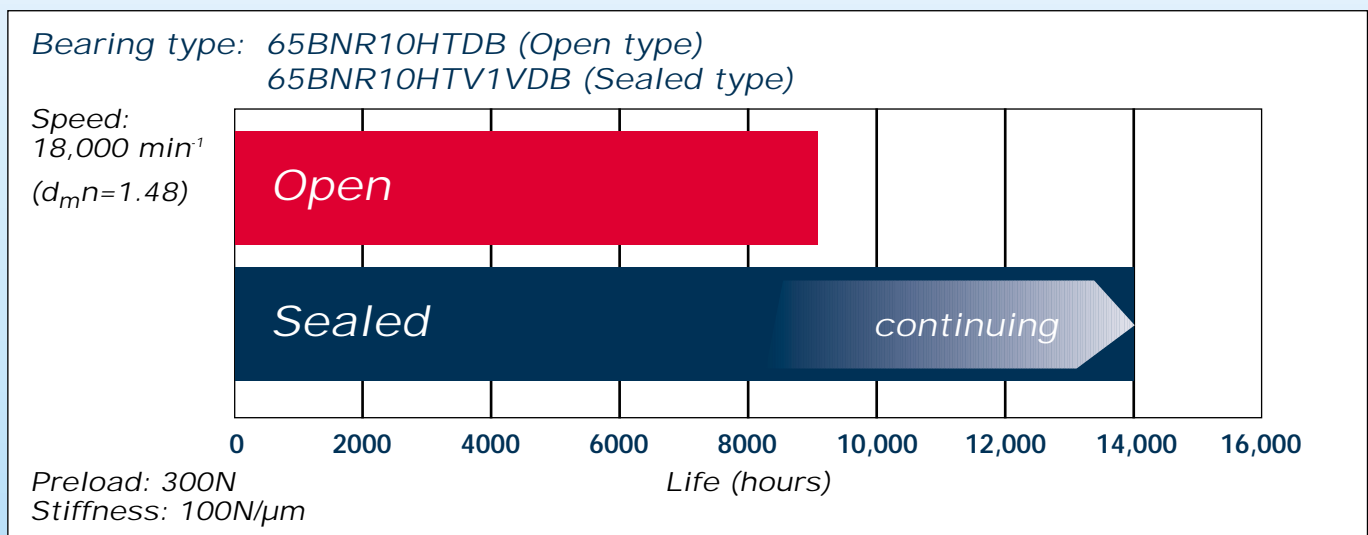

5 reasons to upgrade to Sealed Angular Contact Bearings...

- 1** Grease in optimum quantity and position
- Time Saving for end user
- 2** Clean handling
- Eliminates downtime
- 3** No grease migration in application
- Improved performance
- 4** Reduced external contamination in application
- Higher accuracy
- 5** Longer grease life
- 1.5 times the life of an open greased bearing

Sealed bearings can replace existing open bearings because the external dimensions are identical. They are available in standard and high speed series.

Standard series

Example of bearing number: 7010CTR V1V SU L P3 MTS X

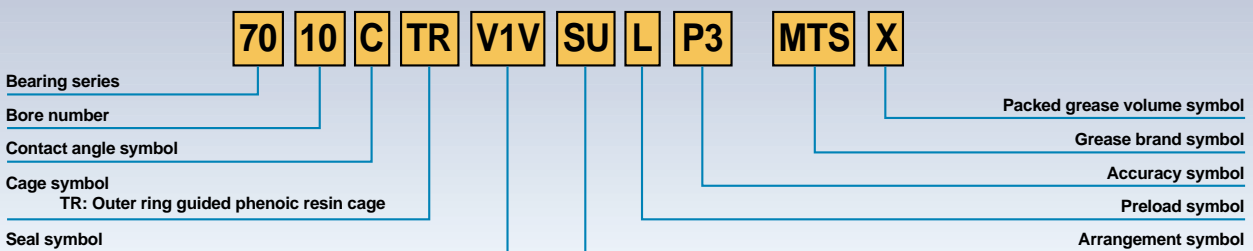

Ultra high-speed Robust series

Example of bearing number: 60BNR10XTV1V SU EL P3 MTS X

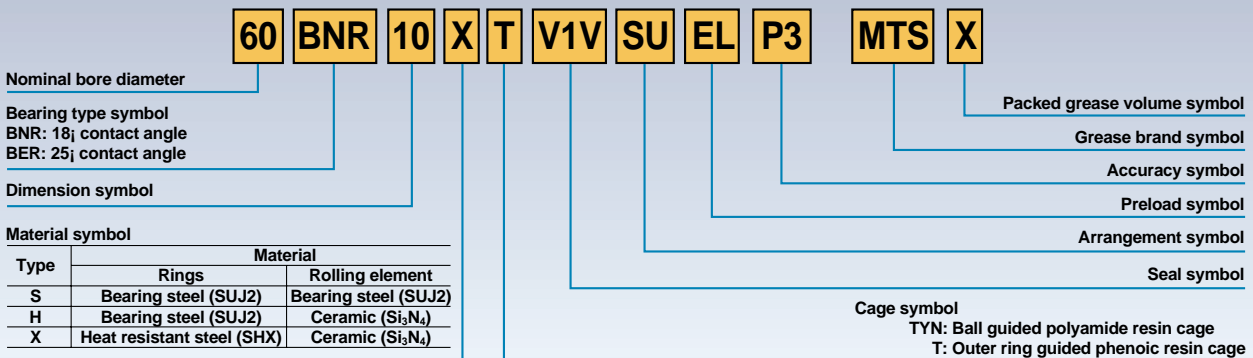

Bearings available with seals

Dimension series	Bearing bore
BNR10, BER10, BNR19, BER19, 70xx, 79xx	Ø 30 to Ø 100mm

Townsend Bearings & Transmissions Limited

**Unit 1, St.Andrews Industrial Estate,
Bridport, Dorset. DT6 3EX. England.**

**Tel : 01308 456933 (UK only) +44 1308 456933 (Outside the UK)
Fax : 01308 427913 (UK only) +44 1308 427913 (Outside the UK)**

Email : sales@townsendbearings.co.uk

www.townsendbearings.co.uk