

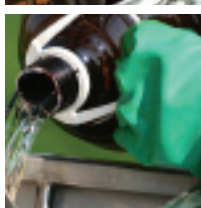

www.rbibearing.com

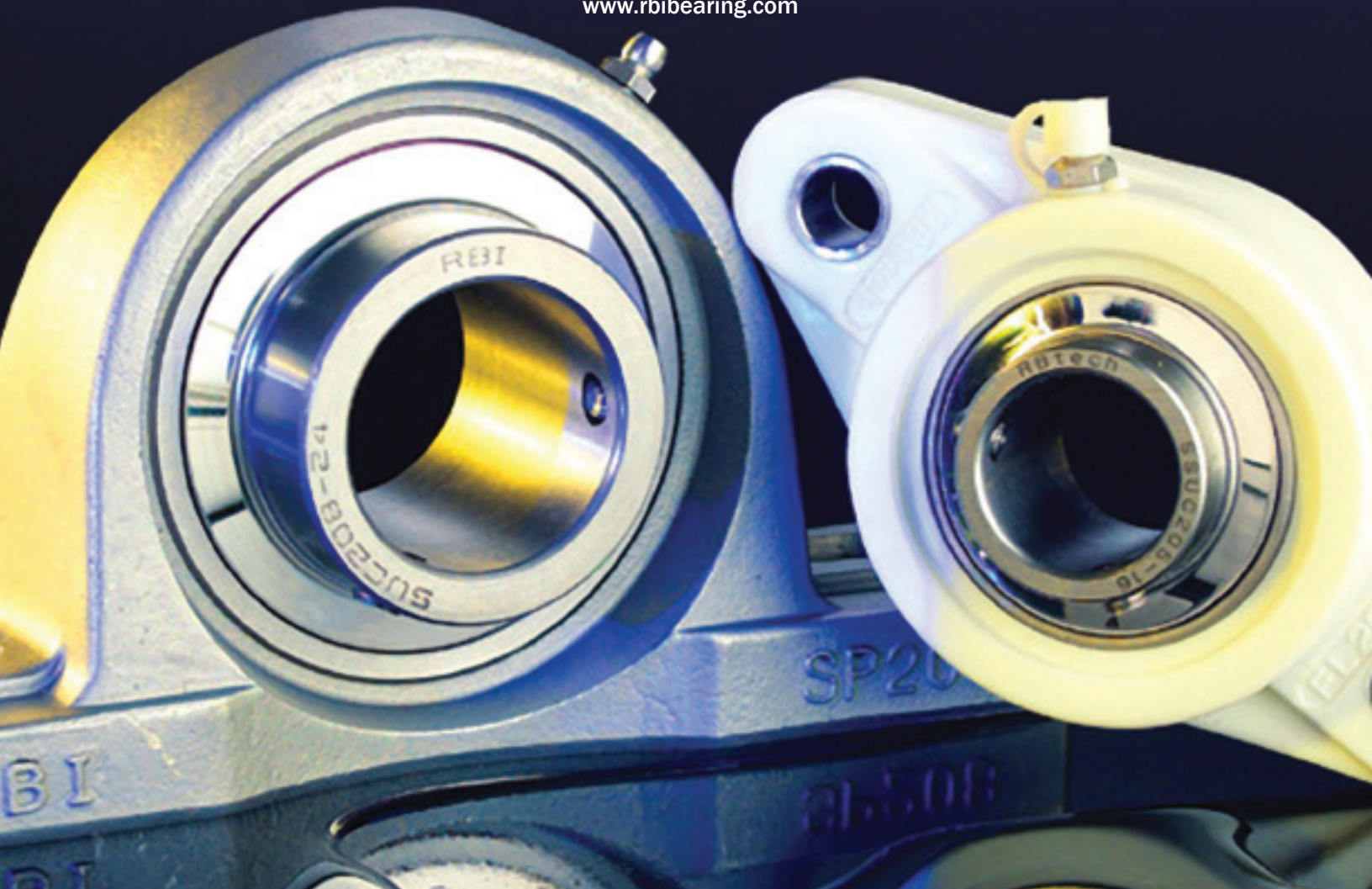

PRODUCT CATALOG

# Stainless Steel & Thermoplastic Mounted Units & Ball Bearings

*The most affordable quality IN THE WORLD >>*



# TABLE OF CONTENTS

Click the page numbers and go to that page.

## STAINLESS STEEL MOUNTED UNITS 4-5

- 4 Pillow Block
- 4 4-Bolt Flange
- 5 2-Bolt Flange

## THERMOPLASTIC MOUNTED UNITS 6-8

- 6 Pillow Block
- 6 4-Bolt Flange
- 7 2-Bolt Flange
- 7 Tap Base Pillow Block
- 8 3-Bolt Flange

## THERMOPLASTIC COVERS AND BACK SEALS 9

- 9 Thermoplastic Covers (Open and Closed)
- 9 Back Seals

## THERMOPLASTIC ENGINEERING DATA 10

- 10 Thermoplastic Housing Break Point Testing
- 10 Thermoplastic Housing and Covers Properties and Characteristics

## STAINLESS STEEL BEARINGS 11-13

- 11 Stainless Steel Insert Bearing SUC Series
- 12 Stainless Steel Single Row Radial Ball Bearings SS6000 & SS6200
- 13 Stainless Steel Single Row Radial Ball Bearings SS6300 & SSR



# Stainless Steel and Thermoplastic Corrosion Resistant Mounted Units.

Our Stainless Steel and Thermoplastic Units outperform under the toughest of conditions. Used in industries such as food and beverage processing, chemical, pharmaceutical, agricultural and in equipment such as electric motors, pumps, conveyor belts, blenders, mixers, picking and weighing machines. They are heat resistant, washable, affordable, come in multiple sizes and 5 housing designs. Our line of corrosive resistant products are reliable and provide excellent protection from oxidation, mold, bacteria, and chemical cleaning agents. Resistant to moisture absorption and harsh environments subject to frequent washdowns and humidity.

### PRODUCT BENEFITS

- Easy to install
- Reduces production downtime
- Complies with food safety regulations
- Long bearing life
- Can be customized to meet specific customer requirements
- RBI offers product stocking programs
- U.S. Engineer on staff to answer all questions

### THERMOPLASTIC

- Cleaning and chemical resistant
- 440C Stainless Steel Bearings
- High Tensile Strength Housings
- Withstands Regular Washdowns
- Mobil FM222 Food Grade Grease
- Solid Stainless Steel Bolt Hole Bushings
- Stainless Steel Grease Fittings

### STAINLESS STEEL

- Cleaning and chemical resistant
- 440C Stainless Steel Bearings
- 304 Stainless Steel Housing
- Withstands Regular Washdowns
- Mobil FM222 Food Grade Grease
- Solid Base Housing
- Stainless Steel Grease Fittings

**ORDERING IS FAST AND EASY! Call: 1-800-708-2128 or Fax: 1-630-295-5490 to order today!**  
 Email your order inquiries to [info@rbibearing.com](mailto:info@rbibearing.com)



## STAINLESS STEEL PILLOW BLOCK

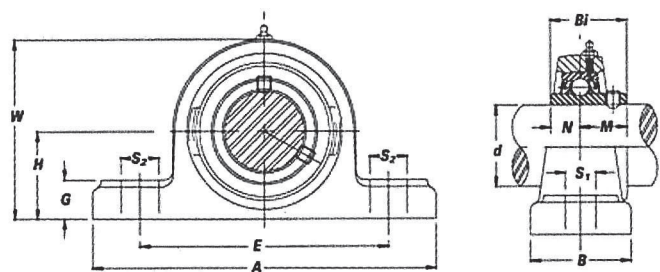

Stainless Steel Pillow Block Grease Fittings are at 45°

BEARING UNIT	SHAFT DIA. (d)		DIMENSIONS (in) or (mm)											BOLT USED		BEARING	HOUSING	WEIGHT (lbs)
	(in)	(mm)	H	A	E	B	S2	S1	G	W	Bi	N	M	(in)	(mm)			
SUCSP 204-12 SUCSP 204	3/4	20	1.3110 33.3	5.0000 127	3.7402 95	1.4961 38	0.7480 19	0.5118 13	0.5118 13	2.5591 65	1.2205 31	0.5000 12.7	0.7205 18.3	3/8	M10	SUC 204-12 SUC 204	SP204	1.54
SUCSP 205-14 SUCSP 205-16 SUCSP 205	7/8	25	1.4370 36.5	5.5118 140	4.1339 105	1.4961 38	0.7480 19	0.5118 13	0.5906 15	2.7953 71	1.3425 34.1	0.5630 14.3	0.7795 19.8	3/8	M10	SUC 205-14 SUC 205-16 SUC 205	SP205	1.87
SUCSP 206-19 SUCSP 206-20 SUCSP 206	1-3/16 1-1/4	30	1.6890 42.9	6.4961 165	4.7638 121	1.8898 48	0.7874 20	0.6693 17	0.6693 17	3.3071 84	1.5000 38.1	0.6260 15.9	0.8740 22.2	1/2	M14	SUC 206-19 SUC 206-20 SUC 206	SP206	2.64
SUCSP 207-20 SUCSP 207-22 SUCSP 207-23 SUCSP 207	1-1/4 1-3/8 1-7/16	35	1.8740 47.6	6.5748 167	5.0000 127	1.8898 48	0.7874 20	0.6693 17	0.7480 19	3.6614 93	1.6890 42.9	0.6890 17.5	1.0000 25.4	1/2	M14	SUC 207-20 SUC 207-22 SUC 207-23 SUC 207	SP207	3.74
SUCSP 208-24 SUCSP 208	1-1/2	40	1.9370 49.2	7.2441 184	5.3937 137	2.1260 54	0.7874 20	0.6693 17	0.7874 20	3.8583 98	1.9370 49.2	0.7480 19	1.1890 30.2	1/2	M14	SUC 208-24 SUC 208	SP208	4.62
SUCSP 209-27 SUCSP 209-28 SUCSP 209	1-11/16 1-3/4	45	2.1260 54	7.4803 190	5.7480 146	2.1260 54	0.7874 20	0.6693 17	0.7874 20	4.1732 106	1.9370 49.2	0.7480 19	1.1890 30.2	1/2	M14	SUC 209-27 SUC 209-28 SUC 209	SP209	5.28
SUCSP 210-31 SUCSP 210-32 SUCSP 210	1-15/16 2	50	2.2520 57.2	8.1102 206	6.2598 159	2.3622 60	0.9843 25	0.7677 19.5	0.8661 22	4.4882 114	2.0315 51.6	0.7480 19	1.2835 32.6	5/8	M16	SUC 210-31 SUC 210-32 SUC 210	SP210	6.38

## STAINLESS STEEL 4-BOLT FLANGE BLOCK

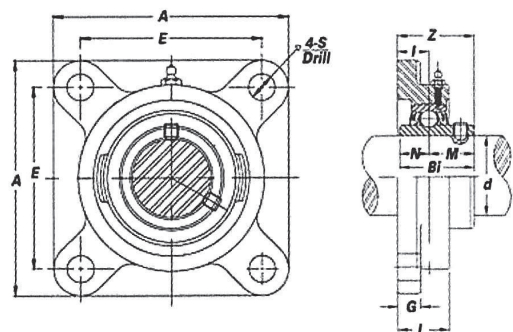

BEARING UNIT	SHAFT DIA. (d)		DIMENSIONS (in) or (mm)											BOLT USED		BEARING	HOUSING	WEIGHT (lbs)
	(in)	(mm)	A	E	I	G	L	S	Z	Bi	N	M	(in)	(mm)				
SUCSF 204-12 SUCSF 204	3/4	20	3.3858 86	2.5197 64	0.5906 15	0.4331 11	0.9843 25	0.4724 12	1.3110 33.3	1.2205 31	0.5000 12.7	0.7205 18.3	3/8	M10	SUC 204-12 SUC 204	SF204	1.32	
SUCSF 205-14 SUCSF 205-16 SUCSF 205	7/8	25	3.7402 95	2.7559 70	0.6299 16	0.5118 13	1.0630 27	0.4724 12	1.4094 35.8	1.3425 34.1	0.5630 14.3	0.7795 19.8	3/8	M10	SUC 205-14 SUC 205-16 SUC 205	SF205	1.89	
SUCSF 206-19 SUCSF 206-20 SUCSF 206	1-3/16 1-1/4	30	4.2520 108	3.2677 83	0.7087 18	0.5118 13	1.2205 31	0.4724 12	1.5827 40.2	1.5000 38.1	0.6260 15.9	0.8740 22.2	3/8	M10	SUC 206-19 SUC 206-20 SUC 206	SF206	2.42	
SUCSF 207-20 SUCSF 207-22 SUCSF 207-23 SUCSF 207	1-1/4 1-3/8 1-7/16	35	4.6063 117	3.6220 92	0.7480 19	0.5906 15	1.3386 34	0.5512 14	1.7480 44.4	1.6890 42.9	0.6890 17.5	1.0000 25.4	7/16	M12	SUC 207-20 SUC 207-22 SUC 207-23 SUC 207	SF207	3.52	
SUCSF 208-24 SUCSF 208	1-1/2	40	5.1181 130	4.0157 102	0.8268 21	0.5906 15	1.4173 36	0.6299 16	2.0157 51.2	1.9370 49.2	0.7480 19	1.1890 30.2	1/2	M14	SUC 208-24 SUC 208	SF208	4.18	
SUCSF 209-27 SUCSF 209-28 SUCSF 209	1-11/16 1-3/4	45	5.3937 137	4.1339 105	0.8661 22	0.6299 16	1.4961 38	0.6299 16	2.0551 52.2	1.9370 49.2	0.7480 19	1.1890 30.2	1/2	M14	SUC 209-27 SUC 209-28 SUC 209	SF209	5.28	
SUCSF 210-31 SUCSF 210-32 SUCSF 210	1-15/16 2	50	5.6299 143	4.3701 111	0.8661 22	0.6299 16	1.5748 40	0.6299 16	2.1496 54.6	2.0315 51.6	0.7480 19	1.2835 32.6	1/2	M14	SUC 210-31 SUC 210-32 SUC 210	SF210	5.72	

Questions? Give us a call at 1-800-708-2128 and one of our knowledgeable, friendly Account Managers can help!

## STAINLESS STEEL 2-BOLT FLANGE BLOCK

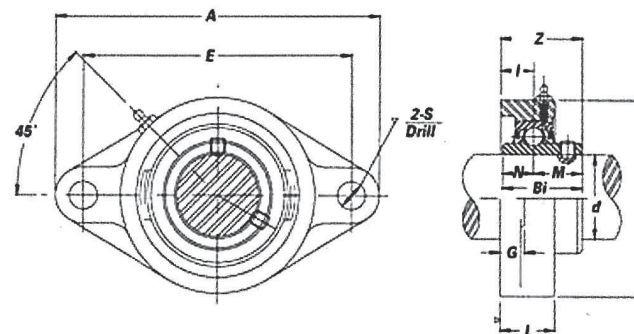

BEARING UNIT	SHAFT DIA. (d)		DIMENSIONS (in) or (mm)											BOLT USED		BEARING	HOUSING	WEIGHT (lbs)
	(in)	(mm)	A	E	I	G	L	S	B	Z	Bi	N	M	(in)	(mm)			
SUCSFL 204-12 SUCSFL 204	3/4	20	4.4488 113	3.5433 90	0.5906 15	0.4331 11	1.0039 25.5	0.4724 12	2.3622 60	1.3110 33.3	1.2205 31	0.5000 12.7	0.5000 18.3	3/8	M10	SUC 204-12 SUC 204	SFL204	1.03
SUCSFL 205-14 SUCSFL 205-16 SUCSFL 205	7/8	25	5.1181 130	3.8976 99	0.6299 16	0.5118 13	1.0630 27	0.4921 12.5	2.6772 68	1.4094 35.8	1.3425 34.1	0.5630 14.3	0.5000 19.8	1/2	M14	SUC 205-14 SUC 205-16 SUC 205	SFL205	1.39
SUCSFL 206-19 SUCSFL 206-20 SUCSFL 206	1-3/16 1-1/4	30	5.8268 148	4.6063 117	0.7087 18	0.5118 13	1.2205 31	0.6299 16	3.1496 80	1.5827 40.2	1.5000 38.1	0.6260 15.9	0.5000 22.2	1/2	M14	SUC 206-19 SUC 206-20 SUC 206	SFL206	1.87
SUCSFL 207-20 SUCSFL 207-22 SUCSFL 207-23 SUCSFL 207	1-1/4 1-3/8 1-7/16	35	6.3386 161	5.1181 130	0.7480 19	0.6299 16	1.3386 34	0.6299 16	3.5433 90	1.7480 44.4	1.6890 42.9	0.6890 17.5	0.5000 25.4	1/2	M14	SUC 207-20 SUC 207-22 SUC 207-23 SUC 207	SFL207	2.64
SUCSFL 208-24 SUCSFL 208	1-1/2	40	6.8898 175	5.6693 144	0.8268 21	0.6299 16	1.4173 36	0.6299 16	3.9370 100	2.0157 51.2	1.9370 49.2	0.7480 19	0.5000 30.2	1/2	M14	SUC 208-24 SUC 208	SFL208	3.52
SUCSFL 209-27 SUCSFL 209-28 SUCSFL 209	1-11/16 1-3/4	45	7.4016 188	5.8268 148	0.8661 22	0.6299 16	1.4961 38	0.6299 16	4.2520 108	2.0551 52.2	1.9370 49.2	0.7480 19	0.5000 30.2	1/2	M14	SUC 209-27 SUC 209-28 SUC 209	SFL209	4.18
SUCSFL 210-31 SUCSFL 210-32 SUCSFL 210	1-15/16 2	50	7.7559 197	6.1811 157	0.8661 22	0.6299 16	1.5748 40	0.7480 19	4.5276 115	2.1496 54.6	2.0315 51.6	0.7480 19	0.5000 32.6	5/8	M16	SUC 210-31 SUC 210-32 SUC 210	SFL210	5.06

Our Stainless Steel and Thermoplastic Units are made for applications subject to moisture, dirt, corrosive and abrasive atmospheres such as:

- Food Processing Plants
- Food Packaging Plants
- Beverage, Brewing, Bottling Plants
- Meat, Poultry, Seafood Processing Plants
- Dairy Industry Plants
- Sugar Processing Plants
- Drug and Pharmaceutical Plants
- Chemical Processing Plants
- Pulp and Paper Mills
- Marine and Naval Applications
- Car and Truck Washes
- Rubber and Plastics Plants
- Refrigeration and Freezer Plants
- Agriculture Harvesting Machinery
- Municipal (Sand/Salt) Treatment Equipment
- A Broad Range of Material Handling Services

ORDERING IS FAST AND EASY! Call: 1-800-708-2128 or Fax: 1-630-295-5490 to order today!  
Email your order inquiries to [info@rbibearing.com](mailto:info@rbibearing.com)



### THERMOPLASTIC PILLOW BLOCK

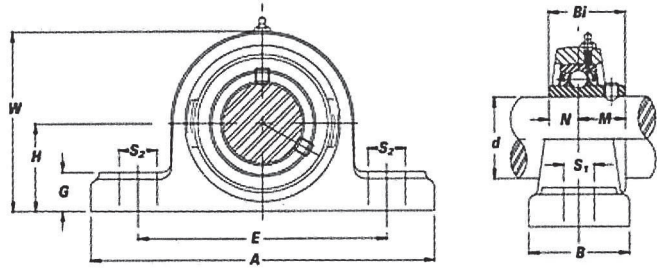

Thermoplastic Pillow Block Grease Fittings are at 0°

BEARING UNIT	SHAFT DIA. (d)		DIMENSIONS (in) or (mm)											BOLT USED		BEARING	HOUSING	WEIGHT (lbs)
	(in)	(mm)	H	A	E	B	S2	S1	G	W	Bi	N	M	(in)	(mm)			
SUCTP 204-12 SUCTP 204	3/4	20	1.3110 33.3	5.0000 127	3.7402 95	1.4961 38	0.5512 14	0.4331 11	0.5591 14.2	2.5787 65.5	1.2205 31	0.5000 12.7	0.7205 18.3	3/8	M10	SUC 204-12 SUC 204	TP204	0.66
SUCTP 205-14 SUCTP 205-16 SUCTP 205	7/8	1	1.4370 36.5	5.5315 140.5	4.1339 105	1.4961 38	0.5512 14	0.4331 11	0.5709 14.5	2.7953 71	1.3386 34	0.5630 14.3	0.7756 19.7	3/8	M10	SUC 205-14 SUC 205-16 SUC 205	TP205	0.76
SUCTP 206-19 SUCTP 206-20 SUCTP 206	1-3/16 1-1/4	30	1.6890 42.9	6.4173 163	4.6850 119	1.8110 46	0.7087 18	0.5512 14	0.7008 17.8	3.3071 84	1.5000 38.1	0.6260 15.9	0.8740 22.2	1/2	M12	SUC 206-19 SUC 206-20 SUC 206	TP206	1.21
SUCTP 207-20 SUCTP 207-22 SUCTP 207-23 SUCTP 207	1-1/4 1-3/8 1-7/16	35	1.8740 47.6	6.6142 168	5.0000 127	1.8898 48	0.7087 18	0.5512 14	0.7087 18	3.7205 94.5	1.6890 42.9	0.6890 17.5	1.0000 25.4	1/2	M12	SUC 207-20 SUC 207-22 SUC 207-23 SUC 207	TP207	1.72
SUCTP 208-24 SUCTP 208	1-1/2	40	1.9370 49.2	7.2441 184	5.3937 137	2.1260 54	0.7087 18	0.5512 14	0.7677 19.5	3.9764 101	1.9370 49.2	0.7480 19	1.1890 30.2	1/2	M12	SUC 208-24 SUC 208	TP208	2.15
SUCTP 209-27 SUCTP 209-28 SUCTP 209	1-11/16 1-3/4	45	2.1260 54	7.5591 192	5.7480 146	2.1260 54	0.7874 20	0.6693 17	0.9055 23	4.1732 106	1.9370 49.2	0.7480 19	1.1890 30.2	5/8	M16	SUC 209-27 SUC 209-28 SUC 209	TP209	2.43
SUCTP 210-31 SUCTP 210-32 SUCTP 210	1-15/16 2	50	2.2520 57.2	8.1102 206	6.2598 159	2.3622 60	0.7874 20	0.6693 17	0.9055 23	4.4882 114	2.0315 51.6	0.7480 19	1.2835 32.6	5/8	M16	SUC 210-31 SUC 210-32 SUC 210	TP210	2.68

### THERMOPLASTIC 2-BOLT FLANGE BLOCK

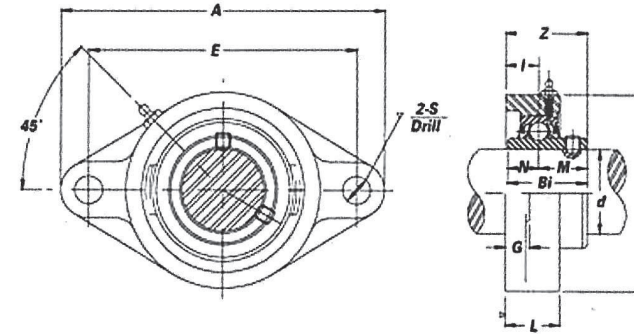

BEARING UNIT	SHAFT DIA. (d)		DIMENSIONS (in) or (mm)											BOLT USED		BEARING	HOUSING	WEIGHT (lbs)
	(in)	(mm)	A	E	I	G	L	S	B	Z	Bi	N	M	(in)	(mm)			
SUCTFL 204-12 SUCTFL 204	3/4	20	4.4488 113	3.5433 90	0.5906 15	0.5276 13.4	1.0433 26.5	0.4331 11	2.5591 65	1.3110 33.3	1.2205 31	0.5000 12.7	0.7205 18.3	3/8	M10	SUC 204-12 SUC 204	TFL204	0.54
SUCTFL 205-14 SUCTFL 205-16 SUCTFL 205	7/8	1	5.1575 131	3.8976 99	0.6496 16.5	0.5630 14.3	1.1024 28	0.4331 11	2.7559 70	1.4252 36.2	1.3386 34	0.5630 14.3	0.7756 19.7	3/8	M10	SUC 205-14 SUC 205-16 SUC 205	TFL205	0.67
SUCTFL 206-19 SUCTFL 206-20 SUCTFL 206	1-3/16 1-1/4	30	5.8268 148	4.6063 117	0.7087 18	0.5630 14.3	1.2008 30.5	0.4331 11	3.1496 80	1.5827 40.2	1.5000 38.1	0.6260 15.9	0.8740 22.2	3/8	M10	SUC 206-19 SUC 206-20 SUC 206	TFL206	0.99
SUCTFL 207-20 SUCTFL 207-22 SUCTFL 207-23 SUCTFL 207	1-1/4 1-3/8 1-7/16	35	6.4567 164	5.1181 130	0.7480 19	0.6102 15.5	1.2598 32	0.5118 13	3.5433 90	1.7480 44.4	1.6890 42.9	0.6890 17.5	1.0000 25.4	1/2	M12	SUC 207-20 SUC 207-22 SUC 207-23 SUC 207	TFL207	1.47
SUCTFL 208-24 SUCTFL 208	1-1/2	40	6.9291 176	5.6693 144	0.8465 21.5	0.6693 17	1.3780 35	0.5512 14	3.9370 100	2.0354 51.7	1.9370 49.2	0.7480 19	1.1890 30.2	1/2	M12	SUC 208-24 SUC 208	TFL208	1.93
SUCTFL 209-27 SUCTFL 209-28 SUCTFL 209	1-11/16 1-3/4	45	7.4409 189	5.8661 149	0.9449 24	0.8268 21	1.6142 41	0.6693 17	4.2520 108	2.1339 54.2	1.9370 49.2	0.7480 19	1.1890 30.2	5/8	M16	SUC 209-27 SUC 209-28 SUC 209	TFL209	2.23
SUCTFL 210-31 SUCTFL 210-32 SUCTFL 210	1-15/16 2	50	7.7559 197	6.1811 157	0.9843 25	0.8268 21	1.6929 43	0.6693 17	4.5276 115	2.2677 57.6	2.0315 51.6	0.7480 19	1.2835 32.6	5/8	M16	SUC 210-31 SUC 210-32 SUC 210	TFL210	2.68

### THERMOPLASTIC 4-BOLT FLANGE BLOCK

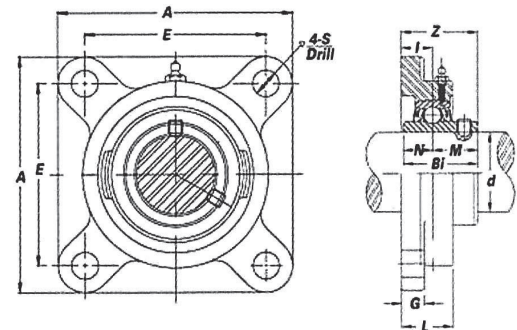

BEARING UNIT	SHAFT DIA. (d)		DIMENSIONS (in) or (mm)											BOLT USED		BEARING	HOUSING	WEIGHT (lbs)
	(in)	(mm)	A	E	I	G	L	S	Z	Bi	N	M	(in)	(mm)				
SUCTF 204-12 SUCTF 204	3/4	20	3.3858 86	2.5000 63.5	0.6417 16.3	0.5276 13.4	1.0945 27.8	0.4331 11	1.3622 34.6	1.2205 31	0.5000 12.7	0.7205 18.3	3/8	M10	SUC 204-12 SUC 204	TF204	0.66	
SUCTF 205-14 SUCTF 205-16 SUCTF 205	7/8	1	3.7402 95	2.7559 70	0.6693 17	0.5630 14.3	1.1220 28.5	0.4331 11	1.4449 36.7	1.3386 34	0.5630 14.3	0.7756 19.7	3/8	M10	SUC 205-14 SUC 205-16 SUC 205	TF205	0.80	
SUCTF 206-19 SUCTF 206-20 SUCTF 206	1-3/16 1-1/4	30	4.2126 107	3.2677 83	0.7480 19	0.5630 14.3	1.2402 31.5	0.4331 11	1.6220 41.2	1.5000 38.1	0.6260 15.9	0.8740 22.2	3/8	M10	SUC 206-19 SUC 206-20 SUC 206	TF206	1.12	
SUCTF 207-20 SUCTF 207-22 SUCTF 207-23 SUCTF 207	1-1/4 1-3/8 1-7/16	35	4.6457 118	3.6220 92	0.8465 21.5	0.6102 15.5	1.3583 34.5	0.5118 13	1.8465 46.9	1.6890 42.9	0.6890 17.5	1.0000 25.4	1/2	M12	SUC 207-20 SUC 207-22 SUC 207-23 SUC 207	TF207	1.65	
SUCTF 208-24 SUCTF 208	1-1/2	40	5.1181 130	4.0157 102	0.9055 23	0.6693 17	1.4370 36.5	0.5512 14	2.0945 53.2	1.9370 49.2	0.7480 19	1.1890 30.2	1/2	M12	SUC 208-24 SUC 208	TF208	2.15	
SUCTF 209-27 SUCTF 209-28 SUCTF 209	1-11/16 1-3/4	45	5.3937 137	4.1339 105	0.9449 24	0.7480 19	1.6142 41	0.6693 17	2.1339 54.2	1.9370 49.2	0.7480 19	1.1890 30.2	5/8	M16	SUC 209-27 SUC 209-28 SUC 209	TF209	2.45	
SUCTF 210-31 SUCTF 210-32 SUCTF 210	1-15/16 2	50	5.6299 143	4.3701 111	0.9843 25	0.8268 21	1.6929 43	0.6693 17	2.2677 57.6	2.0315 51.6	0.7480 19	1.2835 32.6	5/8	M16	SUC 210-31 SUC 210-32 SUC 210	TF210	2.79	

### THERMOPLASTIC TAP BASE PILLOW BLOCK

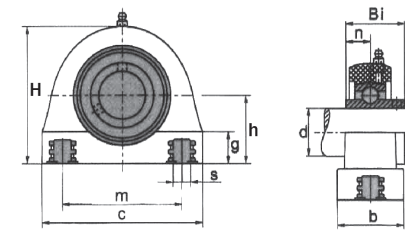

BEARING UNIT	SHAFT DIA. (d)		DIMENSIONS (in) or (mm)											BEARING	HOUSING	WEIGHT (lbs)
	(in)	(mm)	h	b	H	m	C	s	g	n	Bi					
SUCTTB 201-8 SUCTTB 202-10 SUCTTB 204-12 SUCTTB 204	1/2 5/8 3/4	20	1.312 33.3	1.358 34.5	2.594 66	2	50.8	2.87 72.8	3/8	0.51 13	0.50 12.7	1.22 31	SUC 201-8 SUC 202-10 SUC 204-12 SUC 204	TTB204	0.66	
SUCTTB 205-14 SUCTTB 205-16 SUCTTB 205	7/8 1	25	1.437 36.5	1.55 39.5	2.89 73.5	2	50.8	3 76.2	3/8	0.51 13	0.56 14.3	1.34 34.1	SUC 205-14 SUC 205-16 SUC 205	TTB205	0.73	
SUCTTB 206-19 SUCTTB 206-20 SUCTTB 206	1-3/16 1-1/4	30	1.687 42.9	1.65 42	3.30 84	3	76.2	4 101	7/16	0.62 16	0.62 15.9	1.50 38.1	SUC 206-19 SUC 206-20 SUC 206	TTB206	1.21	
SUCTTB 207-20 SUCTTB 207-22 SUCTTB 207-23 SUCTTB 207	1-1/4 1-3/8 1-7/16	35	1.875 47.6	1.85 47	3.75 95	3.25 82.6	4.35 110.5	1/2	0.72 18.5	0.68 17.5	1.68 42.9	SUC 207-20 SUC 207-22 SUC 207-23 SUC 207	TTB207	1.69		
SUCTTB 208-24 SUCTTB 208	1-1/2	40	1.937 49.2	1.889 48	4 100.5	3.50 88.9	4.75 120	1/2	0.78 20	0.75 19	1.93 49.2	SUC 208-24 SUC 208	TTB208	2.10		

Questions? Give us a call at 1-800-708-2128 and one of our knowledgeable, friendly Account Managers can help!

ORDERING IS FAST AND EASY! Call: 1-800-708-2128 or Fax: 1-630-295-5490 to order today!  
Email your order inquiries to info@rbibearing.com



### THERMOPLASTIC 3-BOLT FLANGE

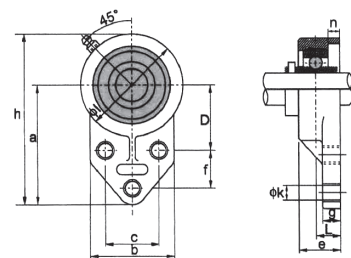

BEARING UNIT	SHAFT DIA. (d)		DIMENSIONS (mm)											BEARING	HOUSING	WEIGHT (lbs)
	(in)	(mm)	a	b	c	D	e	f	g	h	k	n	L			
SUCTFB 201-8 SUCTFB 202-10 SUCTFB 204-12 SUCTFB 204	1/2 5/8 3/4	20	2.46 62.5	2.57 62.5	1.50 38.1	1.68 42.9	1.04 26.5	0.875 22.2	0.55 14	4.25 108	0.437 11	0.50 12.7	0.59 15	SUC 201-8 SUC 202-10 SUC 204-12 SUC 204	TFB204	0.54
SUCTFB 205-14 SUCTFB 205-16 SUCTFB 205	7/8 1	25	3.37 85.7	2.71 69	1.62 41.3	1.88 48	1.10 28	1.12 28.6	0.51 13	4.75 121	0.437 11	0.56 14.3	0.64 16.5	SUC 205-14 SUC 205-16 SUC 205	TFB205	0.67
SUCTFB 206-19 SUCTFB 206-20 SUCTFB 206	1-3/16 1-1/4	30	3.79 96.5	3.26 83	1.81 46.1	2.06 52.4	1.25 32	1.25 31.8	0.51 13	5.45 138.5	0.437 11	0.62 15.9	0.70 18	SUC 206-19 SUC 206-20 SUC 206	TFB206	1.03
SUCTFB 207-20 SUCTFB 207-22 SUCTFB 207-23 SUCTFB 207	1-1/4 1-3/8 1-7/16	35	4.31 109.5	3.70 94	2 50.8	2.37 60.3	1.25 32	1.25 31.8	0.59 15	6.14 156	0.51 13	0.68 17.5	0.74 19	SUC 207-20 SUC 207-22 SUC 207-23 SUC 207	TFB207	1.45

Closed or Open End Caps have a unique sealing system that completely encloses the bearing and protects it from contaminants which helps to prevent premature bearing failure.

### THERMOPLASTIC PLASTIC COVERS (OPEN AND CLOSED)

PART NO.	SHAFT DIA. (d)	DIMENSIONS (mm)					
		in / mm	K	N	L	M	D
204-OC-12 204-CC	3/4 20	32	7	23	50	52	6
205-OC-14 205-OC-16 205-CC	7/8 1	37	7	25	55	62	6
206-OC-19 206-OC-20 206-CC	1-3/16 1-1/4	42	7	30	64	72	6
207-OC-20 207-OC-22 207-OC-23 207-CC	1-1/4 1-3/8 1-7/16	47	7	32	74.5	82	6
208-OC-24 208-CC	1-1/2	52	7	37	84	88	6
209-OC-27 209-OC-28 209-CC	1-11/16 1-3/4	57	7	41	89	93	6
210-OC-31 210-OC-32 210-CC	1-15/16 2	62	7	47	94	98	6

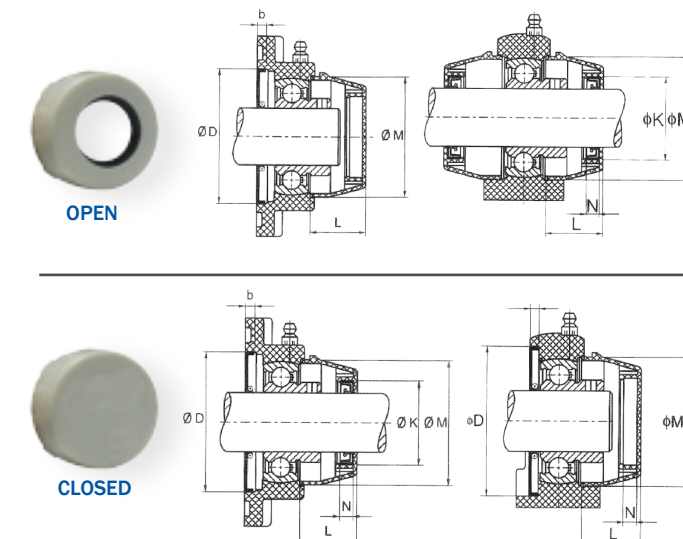

RBI operates Sales, Distribution Centers and Warehouses in the United States, Canada and China. We carry a large inventory of products and schedule shipments daily so YOU can get what you need... *when you need it.*

Spring Loaded Back Seals are designed to help keep out moisture, dust, corrosives and any other particles that could invade the bearing and ultimately cause premature bearing failure.

### BACK SEALS

PART NO.	in / mm	B (mm)		D
204-BS-12 204-BS	3/4 20	6	3	52
205-BS-14 205-BS-16 205-BS	7/8 1 25	6	3	62
206-BS-19 206-BS-20 206-BS	1-3/16 1-1/4 30	6	3	72
207-BS-20 207-BS-22 207-BS-23 207-BS	1-1/4 1-3/8 1-7/16 35	6	3	82
208-BS-24 208-BS	1-1/2 40	6	3	88
209-BS-27 209-BS-28 209-BS	1-11/16 1-3/4 45	6	3	93
210-BS-31 210-BS-32 210-BS	1-15/16 2 50	6	3	98

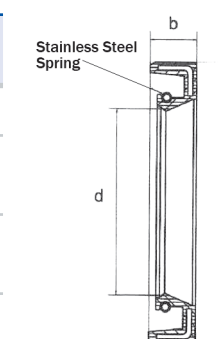

Questions? Give us a call at 1-800-708-2128 and one of our knowledgeable, friendly Account Managers can help!

ORDERING IS FAST AND EASY! Call: 1-800-708-2128 or Fax: 1-630-295-5490 to order today!  
Email your order inquiries to [info@rbibearing.com](mailto:info@rbibearing.com)

**ENGINEERING**

**THERMOPLASTIC HOUSING BREAKING POINT TESTING**

PILLOW BLOCK (TP)							
MODE OF LOAD	BREAKING POINT TEST (KGS)						
	204	205	206	207	208	209	210
	8800	13700	12650	12750	13100	13360	13850
	7700	10000	10600	10800	11100	11400	11750
	5000	8100	5750	7500	8500	8950	9550

4-BOLT FLANGE BLOCK (TF)							
MODE OF LOAD	BREAKING POINT TEST (KGS)						
	204	205	206	207	208	209	210
	12950	13000	17000	18500	19100	19350	19650
	10250	12150	17700	18500	19250	19350	19620
	3250	3350	3380	3520	3790	3850	3990

2-BOLT FLANGE BLOCK (TFL)							
MODE OF LOAD	BREAKING POINT TEST (KGS)						
	204	205	206	207	208	209	210
	11250	11385	16450	16900	17350	17600	17950
	11000	13850	13350	13950	14050	14300	14550
	8500	11100	14200	14900	15150	15350	15650

TAP BASE (TTB)							
MODE OF LOAD	BREAKING POINT TEST (KGS)						
	204	205	206	207	208	209	210
	8210	8540	10370	12150	12230	12900	13850
	6900	7010	6580	8080	9100	10400	11050
	2980	2850	4950	8160	9800	10710	11360

3-BOLT FLANGE BRACKET (TFB)							
MODE OF LOAD	BREAKING POINT TEST (KGS)						
	201	202	203	204	205	206	207
	7200	7200	7200	7200	9100	12200	12900
	9200	9200	9200	9200	11100	11800	11900
	2600	2600	2600	2600	2800	2900	3100

**THERMOPLASTIC HOUSING AND COVERS PROPERTIES AND CHARACTERISTICS**

PROPERTIES	UNIT	TEST METHOD	
<b>MECHANICAL</b>			
Tensile strength at yield	N/mm <sup>2</sup>	ASTM D638	115
at break	N/mm <sup>2</sup>	ASTM D638	
Elongation at yield	%	ASTM D638	3
at break	%	ASTM D638	-
Tensile modulus	N/mm <sup>2</sup>	ASTM D638	8000
Flexural yield strength	N/mm <sup>2</sup>	ASTM D790	-
Flexural yield strength	N/mm <sup>2</sup>	ASTM D790	170
Flexural modulus	N/mm <sup>2</sup>	ASTM D790	7000
Notched impact strength charpy	K/m <sup>2</sup>	DIN53453	12
Hardness H358/10	N/mm <sup>2</sup>	DIN53456	104
H358/60	N/mm <sup>2</sup>	DIN53456	101
Rockwell	-	ASTM D 785	L102
<b>THERMAL</b>			
Oxygen index"	%	ASTM D 2863	19
Flame etardancy"	-	UL stand 94	94HB
(1/6mm thickness)			
Heat resistance, Vicat, method B	°C	ASTM D 1525	210-215
Thermal conductivity	Whm <sup>2</sup> C	ASTM C177	0.19
Mould shrinkage flow	%	ASTM D1299	0.4-0.6
Cross flow direction	%	ASTM D1299	0.6-0.8
<b>PHYSICAL</b>			
Water absorption	-	ASTM D 570	-
24 hrs. 23°C	%	-	0.06

**THE RAW MATERIALS AND CHEMICAL CHARACTERISTICS OF THE RBI THERMOPLASTIC HOUSINGS AND COVERS.**

CHEMICAL MEDIA	°C	IMMULSION% DAYS	% RETENTION OF STRENGTH
<b>ACIDS</b>			
10% hydrochloric acid	23	30	89
	23	90	85
	23	180	82
10% sulfuric	23	30	97
	23	90	94
	23	180	90
36% sulfuric (battery)	23	30	97
	23	180	96
	66	30	84
10% acetic	66	180	35
	23	30	89
	23	180	88
<b>BASES</b>			
5% potassium hydroxide	23	30	83
	23	90	10
10% sodium hydroxide	23	30	2
	23	180	-
10% ammonium hydroxide	23	30	90
	23	90	87
	23	180	58
<b>ORGANIC SOLVENTS</b>			
Ethyl alcohol	23	30	99
	23	180	94
Methyl alcohol	23	30	91
	23	180	76
Isopropyl-alcohol	23	30	100
	23	180	100
Isopropyl-alcohol & water (50:50)	23	30	93
	23	180	96
Turpentine	23	180	92
	23	30	66
Acetone	23	180	63
	23	30	90

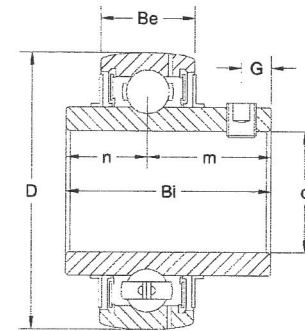

Inner & Outer Rings: 440SS  
 Balls: 440SS  
 Retainer: 302SS  
 Slinger: 302SS  
 Set Screw: 304SS  
 Seal: Buna N Nitrile Triple Lip Seal upon special request  
 Grease: FM222 Food Grade

**SUC STAINLESS STEEL INSERTS**

RBI Stainless Steel insert bearings are designed with extended inner rings for shaft stability and set screw locking. Our standard seal closures include a stainless steel slinger over a Buna Nitrile double lip contact seal for maximum protection during wash-down.

BEARING NO.	Product Specs (dimensions in mm)							
	d	D	Bi	Be	n	m	G	Set Screw Size
SUC204-12	3/4	47	31	17	12.7	18.3	5	1/4-28
SUC204	20	47	31	17	12.7	18.3	5	M6X0.75
SUC205-14	7/8	52	34.1	17	14.3	19.8	5	1/4-28
SUC205-16	1	52	34.1	17	14.3	19.8	5	1/4-28
SUC205	25	52	34.1	17	14.3	19.8	5	M6X0.75
SUC206-19	1-3/16	62	38.1	19	15.9	22.2	5	1/4-28
SUC206-20	1-1/4	62	38.1	19	15.9	22.2	5	1/4-28
SUC206	30	62	38.1	19	15.9	22.2	5	M6X0.75
SUC207-20	1-1/4	72	42.9	20	17.5	25.4	6	5/16/2024
SUC207-22	1-3/8	72	42.9	20	17.5	25.4	6	5/16/2024
SUC207-23	1-7/16	72	42.9	20	17.5	25.4	6	5/16/2024
SUC207	35	72	42.9	20	17.5	25.4	6	M8X1
SUC208-24	1-1/2	80	49.2	21	19	30.2	8	5/16-24
SUC208	40	80	49.2	21	19	30.2	8	M8X1
SUC209-27	1-11/16	85	49.2	22	19	30.2	8	5/16-24
SUC209-28	1-3/4	85	49.2	22	19	30.2	8	5/16-24
SUC209	45	85	49.2	22	19	30.2	8	M8X1
SUC210-31	1-15/16	90	51.6	24	19	32.6	10	3/8-24
SUC210-32	2	90	51.6	24	19	32.6	10	3/8-24
SUC210	50	90	51.6	24	19	32.6	10	M10X1.25

**RBI Competitive Advantage**

RBI Bearing is committed to customer satisfaction by providing superior service, quality bearings and new innovative products. Helping our customers' achieve their goals is our #1 commitment!



All of RBI's Stainless Steel Single Row Radial Ball Bearings are:

- Available with Seals or Shields
- ABEC1
- Mobil Food Grade Grease FM222
- 440 SS Rings
- V1/Z1 Noise and Vibration Level

### STAINLESS STEEL SINGLE ROW RADIAL BALL BEARING SS6000 SERIES

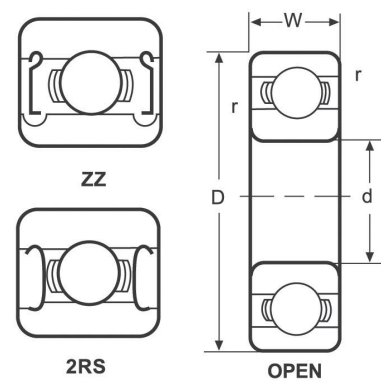

BEARING NO.	BORE d		OUTER DIAMETER D		WIDTH W	
	mm	in	mm	in	mm	in
SS6000	10	.3937	26	1.0236	8	.3150
SS6001	12	.4724	28	1.1024	8	.3150
SS6002	15	.5906	32	1.2598	9	.3543
SS6003	17	.6693	35	1.3780	10	.3937
SS6004	20	.7874	42	1.6535	12	.4724
SS6005	25	.9843	47	1.8504	12	.4724
SS6006	30	1.1811	55	2.1654	13	.5118
SS6007	35	1.3780	62	2.4409	14	.5512
SS6008	40	1.5748	68	2.6772	15	.5906
SS6009	45	1.7717	75	2.9528	16	.6299
SS6010	50	1.9685	80	3.1496	16	.6299

### STAINLESS STEEL SINGLE ROW RADIAL BALL BEARING SS6300 SERIES

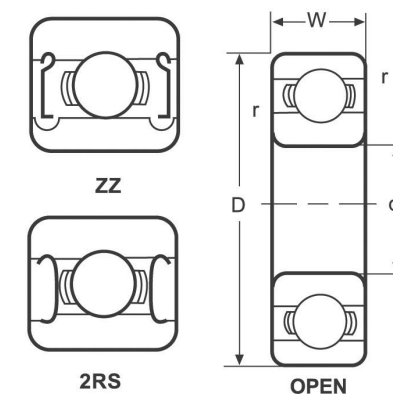

BEARING NO.	BORE d		OUTER DIAMETER D		WIDTH W	
	mm	in	mm	in	mm	in
SS6300	10	.3937	35	1.3780	11	.4331
SS6301	12	.4724	37	1.4567	12	.4724
SS6302	15	.5906	42	1.6535	13	.5118
SS6303	17	.6693	47	1.8504	14	.5512
SS6304	20	.7874	52	2.0472	15	.5906
SS6305	25	.9843	62	2.4409	17	.6693
SS6306	30	1.1811	72	2.8346	19	.7480
SS6307	35	1.3780	80	3.1496	21	.8268
SS6308	40	1.5748	90	3.5433	23	.9055
SS6309	45	1.7717	100	3.9370	25	.9843
SS6310	50	1.9685	110	4.3307	27	1.0630

### STAINLESS STEEL SINGLE ROW RADIAL BALL BEARING SS6200 SERIES

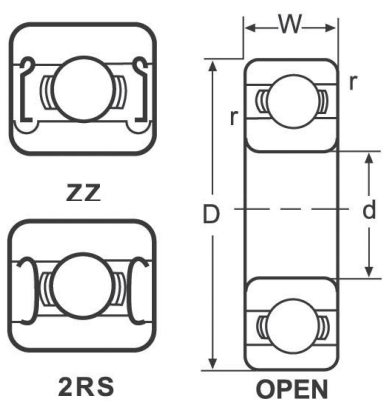

BEARING NO.	BORE d		OUTER DIAMETER D		WIDTH W	
	mm	in	mm	in	mm	in
SS6200	10	.3937	30	1.1811	9	.3543
SS6201	12	.4724	32	1.2598	10	.3937
SS6202	15	.5906	35	1.3780	11	.4331
SS6203	17	.6693	40	1.5748	12	.4724
SS6204	20	.7874	47	1.8504	14	.5512
SS6205	25	.9843	52	2.0472	15	.5906
SS6206	30	1.1811	62	2.4409	16	.6299
SS6207	35	1.3780	72	2.8346	17	.6693
SS6208	40	1.5748	80	3.1496	18	.7087
SS6209	45	1.7717	85	3.3465	19	.7480
SS6210	50	1.9685	90	3.5433	20	.7874

### STAINLESS STEEL SINGLE ROW RADIAL BALL BEARING SSR INCH SERIES

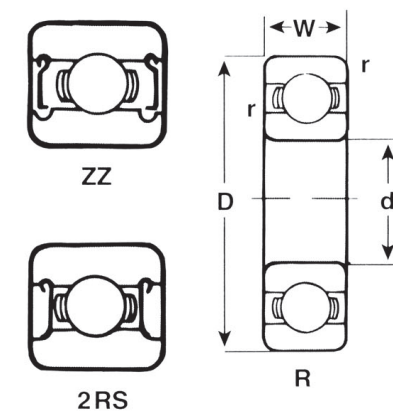

BEARING NO.	BORE d		OUTER DIAMETER D		WIDTH W (in) / Wi (in)			
	FRACTION	in	FRACTION	in	OPEN	SHIELDED	OPEN	SHIELDED
SSR2	1/8	.1250	3/8	.3750	.1562	.1562	.1875	.1875
SSR3	3/16	.1875	1/2	.5000	.1562	.1960	.2272	.2272
SSR3A	3/16	.1875	1/2	.5000	.1960	.1960	-	-
SSR4	1/4	.2500	5/8	.6250	.1960	.1960	.2272	.2272
SSR6	3/8	.3750	7/8	.8750	.2188	.2812	-	-
SSR8	1/2	.5000	1-1/8	1.1250	.2500	.3125	-	-
SSR10	5/8	.6250	1-3/8	1.3750	.2812	.3438	-	-
SSR12	3/4	.7500	1-5/8	1.6250	.3125	.4375	-	-
SSR14	7/8	.8750	1-7/8	1.8750	.3750	.5000	-	-
SSR16	1	1.0000	2	2.0000	.3750	.5000	-	-
SSR18	1-1/8	1.1250	2-1/8	2.1250	.3750	.5000	-	-
SSR20	1-1/4	1.2500	2-1/4	2.2500	.3750	.5000	-	-
SSR22	1-3/8	1.3750	2-1/2	2.5000	.4375	.5625	-	-
SSR24	1-1/2	1.5000	2-5/8	2.6250	.4375	.5625	-	-

Questions? Give us a call at 1-800-708-2128 and one of our knowledgeable, friendly Account Managers can help!

ORDERING IS FAST AND EASY! Call: 1-800-708-2128 or Fax: 1-630-295-5490 to order today!  
Email your order inquiries to [info@rbibearing.com](mailto:info@rbibearing.com)

Stainless Steel and Thermoplastic  
Corrosion Resistant Mounted Units.

*The most affordable  
quality in the world.*

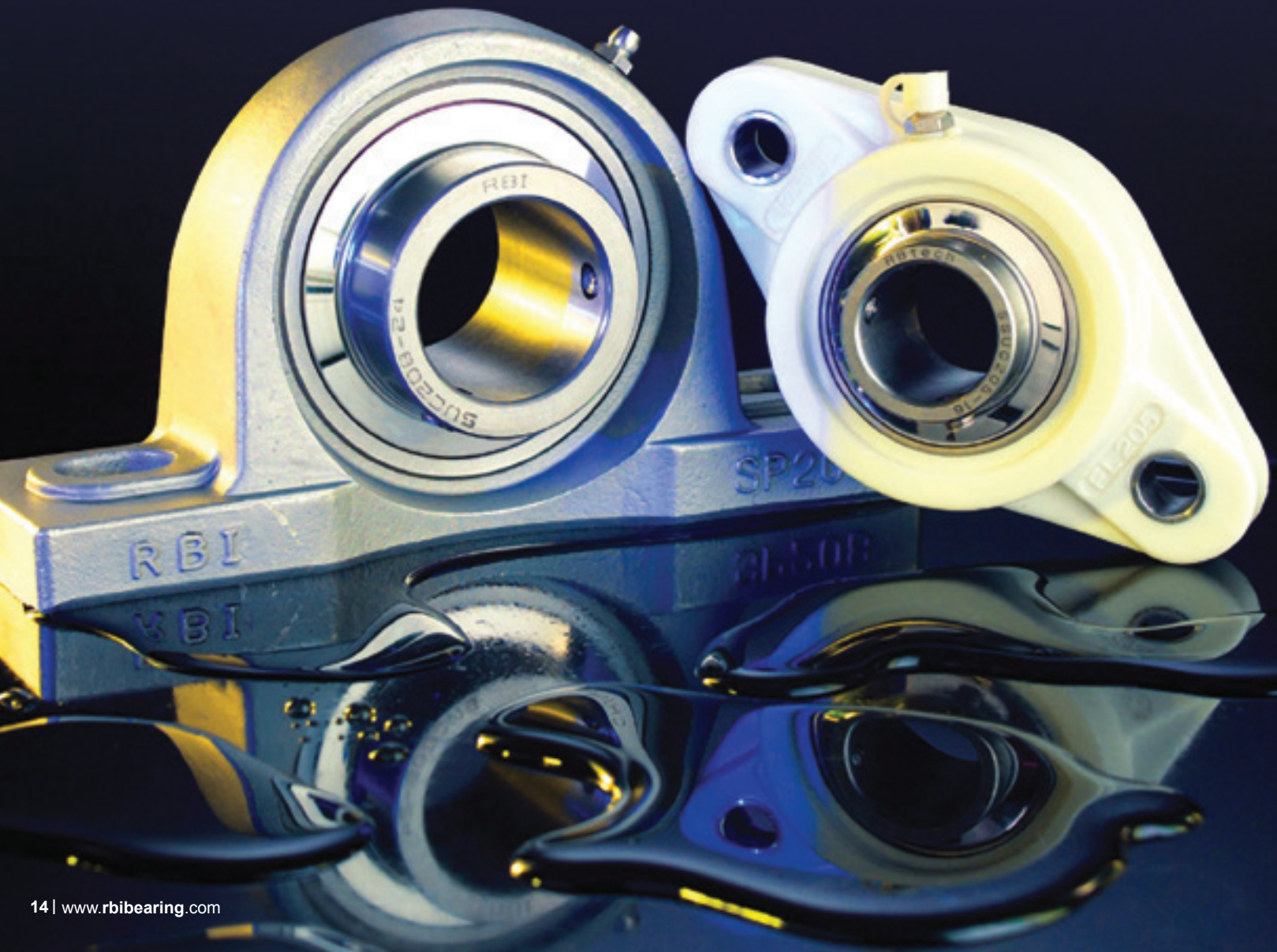

For over two decades, RBI Bearing, Inc. has been providing high quality precision bearing products at affordable prices to markets throughout North America, South America and Europe. With a highly skilled engineering and production team in China backed by an experienced western sales staff, RBI brings a “best of both worlds” approach to the clients we serve.

RBI specializes in manufacturing small and middle-size low noise deep groove ball bearings, special machinery for bearing production, and develops specific usage bearings to meet the requirements of each customer. Our production management complies ISO-9000:2001, TS16949 and we are committed to supplying the international market with the most reliable and cost effective ball bearings produced in China.

RBI Bearing operates Sales and Distribution Centers in the United States, Canada, Japan and China.







www.rbibearing.com

**RBI BEARING UNITED STATES**  
**CHICAGO - Headquarters**  
1055 Stevenson Court, 102W  
Roselle, IL, 60172  
800 708-2128 (toll-free)

**LOS ANGELES**  
13450 Brooks Dr # B  
Baldwin Park, CA 91706  
800 358-7652 (toll-free)

**RBI BEARING CANADA**  
**TORONTO**  
1790 Bonhill Road  
Mississauga, ON L5T 1 C8  
800-724-2426 (toll free)

**CALGARY**  
4900 64th Ave S.E., Bay #70  
Calgary, Alberta T2C 4V3  
800-724-2426 (toll free)

**RBI BEARING CHINA**  
No.60 Liulv Road  
Hudai Industrial Zone  
Wuxi, Jiangsu, China  
86-510-8521-3931



### Join the RBI mailing list!

Scan the QR code and sign up for our eblast's and get the latest information on RBI's products, services and news updates within the bearing industry.

PRODUCT CATALOG

# Stainless Steel & Thermoplastic Mounted Units & Ball Bearings

15SS2



*The most affordable quality IN THE WORLD >>*