

For New Technology Network

NTN®

General Catalog for Office Equipment Products



CAT. No. 8701-II/E



NTN General Catalog for Office Equipment Products

— Introduction to Copy Machine and Printer Compatible Products —

Because of the expanded use of personal computers, Internet and other digital equipment, multi-function copy machine and printers are now used around the world as image outputting equipment. Such office equipment have many different bearings built into them to meet various needs.

In order to concentrate many different functions in a small space, NTN has been providing products that save space and are easy to maintain. These are made possible by the creation of key technology that helps us to realize highly reliable products.

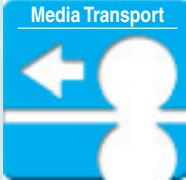
■ Usage Locations and Compatible NTN Products

		Page
	Ball bearings	<ul style="list-style-type: none"> • Conductive bearings 9 • Chemical attack preventing bearings10 • Thin-type ball bearings12
	Resin products	<ul style="list-style-type: none"> • Bearings for cartridges24 • Bearing units with seals25
	Sintered products	• Hybrid BEARPHITE33
	Torque limiters	<ul style="list-style-type: none"> • Torque limiter unit (NTS type)47, 48 • Torque limiter unit (NTB type)49
	Clutches	• One-way clutch unit NCU model, NCZC model, NCZ model, NCZX model, NCUX model60, 61
		Ball bearings
Resin products		• Blades24
Sintered products		• NTN BEARPHITE 36~45
Torque limiters		<ul style="list-style-type: none"> • Torque limiter unit (NTS type)47, 48 • Torque limiter unit (NTB type)49
Clutches		• One-way clutch unit NCU model, NCZC model, NCZ model, NCZX model, NCUX model60, 61
		Ball bearings
	Resin products	<ul style="list-style-type: none"> • Separating pins21 • Separating plates, sliding bearings21, 22 • Insulation sleeves22 • Fusing gears23 • Paper Ejection Parts (rollers, ribs)23
	Clutches	• One-way clutch unit NCZC model, NCZ model, NCZX model, NCUX model60, 61

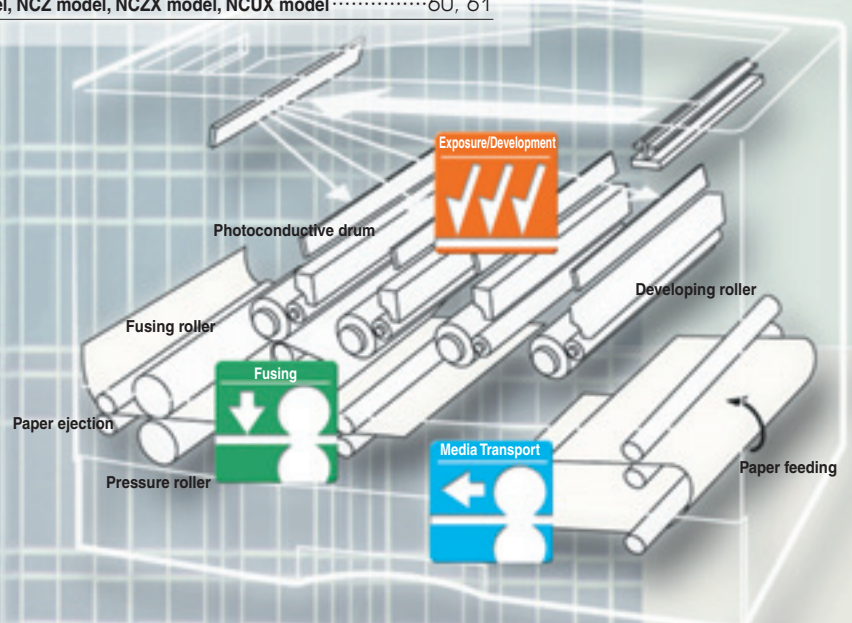

CONTENTS

Ball Bearings



67 series

BEAREE

BEAREE AS5021



BEAREE AS5054

BEARPHITE



HYBRID BEARPHITE

Torque Limitter



NTS Type

Clutches

One-way Clutch



One-way Clutch Unit

I Ball bearings

1. Description of Ball Bearings 3
2. High-temperature, Long-life Bearings 8
3. Conductive Bearings 9
4. Chemical Attack Preventing Bearings 10
5. Integrated Rotation Sensor Bearings 11
6. Thin-type Ball Bearings (Series 67) 12
7. Miniature and Extra Small Ball Bearings 14
8. Deep Groove Ball Bearings 16
9. Bearings with Snap Ring Grooves and Snap Rings 18

II Resin products

1. Separating Pins 21
2. Separating Plates 21
3. Slide Bearings 22
4. Insulation Sleeves 22
5. Fusing Gears 23
6. Paper Output Parts (roller, rib) 23
7. Cleaning Blades 24
8. Bearings for Cartridges 24
9. Bearing Units with Seals 25
10. BEAREE Selection Guidelines 26
11. Base Resins and Characteristics of Major Grades 27

III Sintered products

1. Oil-impregnated Sintered Bearings "NTN BEARPHITE" 29
2. Hybrid BEARPHITE Bearings 33
3. Hydrodynamic BEARPHITE Bearings 34
4. Products under Development 35
5. NTN BEARPHITE Standard Products 36

IV Torque limiters

1. Torque Limiter Units (NTS Type) 47
2. Torque Limiter Unit (NTB 14 Type) 49

V Clutches

1. NTN One-way Clutch 51
2. One-way Clutch Unit Specifications 55
3. Technical Data 55
4. One-way Clutch 56
5. One-way Clutch Units 60
6. Torque Diodes 62
7. Introduction to Products Being Developed 64



I Ball Bearings

1. Description of Ball Bearings	3
2. High-temperature, Long-life Bearings	8
3. Conductive Bearings	9
4. Chemical Attack Preventing Bearings	10
5. Integrated Sensor Bearings	11
6. Thin-type Ball Bearings (Series 67)	12
7. Miniature and Extra Small Ball Bearings	14
8. Deep Groove Ball Bearings	16
9. Bearings with Snap Ring Grooves and Snap Rings	18

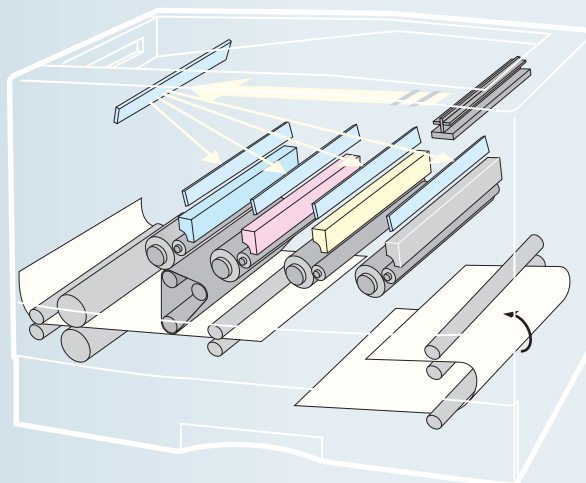

1. Description of Ball Bearings



1.1 Main dimensions and numbering conventions

Table 1 Bearing Number Composition and Arrangement

Supplementary prefix code	Basic number					
	Special application/material/heat treatment code	Bearing series			Bore diameter	
		Bearing series code	Dimension series code		Code	Bore diameter mm
Width/height series ¹⁾	Diameter series					
F- Stainless steel bearings (~120°C)	Deep groove ball bearings (type code 6)			/0.6	0.6	
	68	(1)	8	/1.5	1.5	
	69	(1)	9	/2.5	2.5	
TS2- Dimension stabilized bearings for high temperature use to 160°C	60	(1)	0	1	1	
	62	(0)	2	9	9	
	63	(0)	3			
TS3- Dimension stabilized bearings for high temperature use to 200°C				00	10	
				01	12	
				02	15	
				03	17	
TS4- Dimension stabilized bearings for high temperature use to 250°C				/22	22	
				/28	28	
				/32	32	
				04	20	
				05	25	
				06	30	
				07	35	
				08	40	
				09	45	

Supplementary suffix codes						
Cage code ¹⁾	Seal/Shield code	External configuration code	Duplex arrangement code	Internal clearance/preload code ¹⁾	Tolerance code	Lubrication code
(J) Pressed steel cage	LLB Synthetic rubber seal (non-contact type)	N With snap ring groove	D2 Two matched, paired bearings	C2 Internal clearance less than normal	P6 JIS Class 6	/2AS Shell Alvania S2 grease
				(CN) Normal clearance	P5 JIS Class 5	/3AS Shell Alvania S3 grease
T2 Plastic mold cage	LLU Synthetic rubber seal (contact type)	NR With snap ring		C3 Internal clearance greater than normal	P4 JIS Class 4	/8A Shell Alvania EP2 grease
				C4 Internal clearance greater than C3	P2 JIS Class 2	/5K Multemp SRL
				C5 Internal clearance greater than C4		/LX11 Barrierta JFE552
				CM Radial internal clearance for electric motor use		
	LLH Synthetic rubber seal (low-torque type)					
	ZZ Steel shield					

Note 1) The characters in parentheses will not be shown in the bearing numbers.

Remark: Please consult with NTN regarding any bearing number codes, prefixes and suffixes not shown in the tables above.

1.2 Basic bearing numbers and supplementary symbols (Miniature and Extra small ball bearings)

Table 2

Supplementary symbols to be placed before the basic numbers	Symbol for materials	Without symbol High carbon chrome bearing steel F Stainless steel
Basic number		67, 68, 69, } Radial ball bearings, Metric series 60, 62, 63, } BC
		W Radial ball bearings, wider than standard width (shielded type)
		WA Radial ball bearings, other sizes than standard ones
		FL Flanged outer rings
		FLA Flanged outer rings, provided non-standard flange dimensions

		T2	ZZ1	CNS	P5	1K
Supplementary symbols to be placed after the basic numbers	Cage symbol	Stainless steel cage J1 Synthetic resin cage T2				
	Shield/seal symbol	Steel shield plate Z, ZZ Steel shield plate (with snap ring) ZA, ZZA Stainless steel shield plate Z1, ZZ1 Stainless steel shield plate (with snap ring) ZA1, ZZA1 Non-contact rubber (miniature ball bearings) LF, LLF Non-contact nylon SA, SSA Non-contact type rubber LB, LLB Contact type rubber LU, LLU				
	Clearance symbol	JIS CN clearance (normal clearance) Without symbol JIS C2 clearance (clearance smaller than CN) C2 JIS C3 clearance (clearance greater than CN) C3 JIS C4 clearance (clearance greater than C3) C4 Low group of JIS C2 clearance (MIL tight clearance) C2S Low group of JIS CN clearance (MIL tight clearance) CNS Medium group of JIS CN clearance (MIL standard clearance) CNM High group of JIS CN clearance (MIL standard clearance) CNL Low group of JIS C3 clearance (MIL standard clearance) C3S Medium group of JIS C3 clearance (MIL loose clearance) C3M High group of JIS C3 clearance (MIL extra loose clearance) C3L				
	Precision grade symbol	JIS class 0 Without symbol JIS class 6 P6 JIS class 5 P5 JIS class 4 P4 JIS class 2 P2 NTN PS class 5 PS5 Special precision PX1...n NTN PS class 4 PS4				
	Sealed lubricant symbol	Multemp PS No. 2 (Kyodo Yushi) 1K Alvania S2 (SHELL) MIL-G-18709 2AS Beacon 325 (ESSO) MIL-G-23827A 3E Isoflex Super LDS18 (KLÜBER) 6K Multemp SRL (Kyodo Yushi) 5K Winsor Lube L-245X (ANDERSON) MIL-L-6085 1W				
	Special symbol	Special specifications V1...Vn				

1.3 Bearing tolerances

Table 3 Tolerance of Radial Bearings Inner rings

Units: μm

Nominal bore diameter d mm	Dimensional tolerance of mean bore diameter within plane Δ_{dmp}										Bore diameter variation V_{dP}																	
	over	incl.	Class 0		Class 6		Class 5		Class 4 ¹⁾		Class 2 ¹⁾		Diameter series 9					Diameter series 0, 1					Diameter series 2, 3, 4					
			high	low	high	low	high	low	high	low	high	low	high	low	high	low	high	low	high	low	high	low	high	low	high	low	high	low
			max		max		max		max		max		max		max		max		max		max		max		max		max	
0.6 ²⁾	2.5	0	-8	0	-7	0	-5	0	-4	0	-2.5	10	9	5	4	2.5	8	7	4	3	2.5	6	5	4	3	2.5		
2.5	10	0	-8	0	-7	0	-5	0	-4	0	-2.5	10	9	5	4	2.5	8	7	4	3	2.5	6	5	4	3	2.5		
10	18	0	-8	0	-7	0	-5	0	-4	0	-2.5	10	9	5	4	2.5	8	7	4	3	2.5	6	5	4	3	2.5		
18	30	0	-10	0	-8	0	-6	0	-5	0	-2.5	13	10	6	5	2.5	10	8	5	4	2.5	8	6	5	4	2.5		
30	50	0	-12	0	-10	0	-8	0	-6	0	-2.5	15	13	8	6	2.5	12	10	6	5	2.5	9	8	6	5	2.5		
50	80	0	-15	0	-12	0	-9	0	-7	0	-4	19	15	9	7	4	19	15	7	5	4	11	9	7	5	4		

Note 1) The dimensional difference Δ_{ds} of the bore diameter to be applied to Class 4 and 2 is the same as the tolerance of the dimensional difference Δ_{dmp} of the mean bore diameter. However, the dimensional difference is applied to diameter series 0, 1, 2, 3 and 4 for Class 4, and to all the diameter series for Class 2.

Units: μm

Nominal bore diameter d mm	Mean bore diameter variation V_{dmp}					Radial runout K_{ia}					Side runout S_d			Axial runout S_{ia}			Width deviation Δ_{BS}						Width variation V_{BS}									
	over	incl.	Class 0		Class 6		Class 5		Class 4		Class 2		Class 5	Class 4	Class 2	Normal			Modified			Class 0	Class 6	Class 5	Class 4	Class 0	Class 6	Class 5	Class 4			
			high	low	high	low	high	low	high	low	high	low				high	low	high	low													
			max		max		max		max		max					high	low	high	low	high	low									high	low	max
0.6 ²⁾	2.5	6	5	3	2	1.5	10	5	4	2.5	1.5	7	3	1.5	7	3	1.5	0	-40	0	-40	0	-40	—	—	0	-250	12	12	5	2.5	1.5
2.5	10	6	5	3	2	1.5	10	6	4	2.5	1.5	7	3	1.5	7	3	1.5	0	-120	0	-40	0	-40	0	-250	0	-250	15	15	5	2.5	1.5
10	18	6	5	3	2	1.5	10	7	4	2.5	1.5	7	3	1.5	7	3	1.5	0	-120	0	-80	0	-80	0	-250	0	-250	20	20	5	2.5	1.5
18	30	8	6	3	2.5	1.5	13	8	4	3	2.5	8	4	1.5	8	4	2.5	0	-120	0	-120	0	-120	0	-250	0	-250	20	20	5	2.5	1.5
30	50	9	8	4	3	1.5	15	10	5	4	2.5	8	4	1.5	8	4	2.5	0	-120	0	-120	0	-120	0	-250	0	-250	20	20	5	3	1.5
50	80	11	9	5	3.5	2	20	10	5	4	2.5	8	5	1.5	8	5	2.5	0	-150	0	-150	0	-150	0	-380	0	-250	25	25	6	4	1.5

Note 2) Bearings with nominal bore diameters of 0.6 mm are included in this dimensional category.

Table 4 Tolerance of Radial Bearings Outer rings

Units: μm

Nominal outer diameter D mm	Dimensional tolerance of mean outer diameter within plane Δ_{Dmp}										Outer diameter variation ⁴⁾ V_{DP}																	
	over	incl.	Class 0		Class 6		Class 5		Class 4 ³⁾		Class 2 ³⁾		Diameter series 9					Diameter series 0, 1					Diameter series 2, 3, 4					
			high	low	high	low	high	low	high	low	high	low	high	low	high	low	high	low	high	low	high	low	high	low	high	low	high	low
			max		max		max		max		max		max		max		max		max		max		max		max		max	
2.5 ⁵⁾	6	0	-8	0	-7	0	-5	0	-4	0	-2.5	10	9	5	4	2.5	8	7	4	3	2.5	6	5	4	3	2.5		
6	18	0	-8	0	-7	0	-5	0	-4	0	-2.5	10	9	5	4	2.5	8	7	4	3	2.5	6	5	4	3	2.5		
18	30	0	-9	0	-8	0	-6	0	-5	0	-4	12	10	6	5	4	9	8	5	4	4	7	6	5	4	4		
30	50	0	-11	0	-9	0	-7	0	-6	0	-4	14	11	7	6	4	11	9	5	5	4	8	7	5	5	4		
50	80	0	-13	0	-11	0	-9	0	-7	0	-4	16	14	9	7	4	13	11	7	5	4	10	8	7	5	4		
80	120	0	-15	0	-13	0	-10	0	-8	0	-5	19	16	10	8	5	19	16	8	6	5	11	10	8	6	5		

Note 3) The dimensional difference Δ_{ds} of the bore diameter to be applied to Class 4 and 2 is the same as the tolerance of the dimensional difference Δ_{Dmp} of the mean bore diameter. However, the dimensional difference is applied to diameter series 0, 1, 2, 3 and 4 for Class 4, and to all the diameter series for Class 2.

Units: μm

Nominal outer diameter D mm	Outer diameter ⁴⁾ variation V_{DP}		Mean outer diameter variation V_{Dmp}					Radial runout K_{ea}					Outside surface inclination S_D			Axial runout S_{ea}			Width deviation Δ_{CS}	Width variation V_{CS}										
	over	incl.	Sealed/shield bearings diameter series 2,3,4		0,1,2,3,4		Class 0	Class 6	Class 5	Class 4	Class 2	Class 0	Class 6	Class 5	Class 4	Class 2	Class 5	Class 4	Class 2	All types	Class 0, 6	Class 5	Class 4	Class 2						
			high	low	high	low																			high	low	high	low	high	low
			max		max																				max		max		max	
2.5 ⁵⁾	6	10	9	6	5	3	2	1.5	15	8	5	3	1.5	8	4	1.5	8	5	1.5	Depends on tolerance of Δ_{BS} in relation to d of same bearing	5	2.5	1.5							
6	18	10	9	6	5	3	2	1.5	15	8	5	3	1.5	8	4	1.5	8	5	1.5	Depends on tolerance of V_{BS} in relation to d of same bearing	5	2.5	1.5							
18	30	12	10	7	6	3	2.5	2	15	9	6	4	2.5	8	4	1.5	8	5	2.5	5	2.5	1.5								
30	50	16	13	8	7	4	3	2	20	10	7	5	2.5	8	4	1.5	8	5	2.5	6	3	1.5								
50	80	20	16	10	8	5	3.5	2	25	13	8	5	4	8	4	1.5	10	5	4	8	4	2.5								
80	120	26	20	11	10	5	4	2.5	35	18	10	6	5	9	5	2.5	11	6	5	8	4	2.5								

Note 4) To be applied in case snap rings are not installed on the bearings. Note 5) Nominal outer diameter of bearings of 2.5 mm is included in this dimensional category.

Table 5 Tolerance of Outer Ring Flange

Precision grade	Outer tolerance		Outer surface inclination relevant to the back side S_{D1} max	Backside axial runout S_{ea1} max	Width deviation		Width variation V_{C1s} or V_{C2s} max	Units: μm ※			
	Δ_{D1s} or Δ_{D2s}				Δ_{C1s} or Δ_{C2s}			Nominal flange outer diameter D_1 or D_2 (mm)		Outer diameter deviation Δ_{D1s} or Δ_{D2s}	
	high	low	high	low	high	low	over	incl.	high	low	
ISO standards	Class 0	—		—	—		Same as the V_{BS} of the bore of the same bearing.	10	18	+220	-36
	Class 6	—		—	—						
	Class 5	8		11	5						
	Class 4	4		7	2.5						
	Class 2	1.5		$\frac{3}{4}$ ¹⁾	1.5						

Note 1) Applicable to bearings with a nominal outer diameter D of 18 mm or less.

Table 6 NTN Standards for High Precision and Low Noise Bearings ($\phi D \leq 18$ mm)

(1) Tolerance of inner ring

Precision grade	Mean bore tolerance		Bore tolerance		Bore variation V_{dP} max	Mean bore variation V_{dmp} max	Radial runout K_{ia} max	Bore surface inclination S_d max	Axial runout S_{ia} max	Width deviation		Width variation V_{BS} max
	Δ_{dmp}		Δ_{dS}							Δ_{BS}		
	high	low	high	low	high	low	high	low				
PS 5	0	-5	0	-5	1	1	2.5	3	3	0	-40	2.5
PS 4	0	-5	0	-5	1	1	1.5	2.5	2.5	0	-40	2.5

(2) Tolerance of outer ring

Precision grade	Mean outer diameter tolerance		Outer diameter tolerance			Outer diameter variation			Mean outer diameter variation V_{Dmp} max	Radial runout K_{ea} max	Outer diameter surface inclination S_D max	Axial runout S_{ea} max	Width deviation		Width variation V_{CS} max		
	Δ_{Dmp}		Δ_{DS}			V_{DD}							Δ_{CS}				
	high	low	Open bearings	Shield bearings	Sealed bearings	Open bearings	Shield bearings	Sealed bearings	high	low							
PS 5	0	-5	0	-5	+1 -6	0	-5	1	3	1.5	1	5	8	8	0	-40	2.5
PS 4	0	-5	0	-5	+1 -6	0	-5	1	3	1.5	1	2.5	4	2.5	0	-40	2.5

1.4 Bearing internal clearance

Bearing internal clearance refers to the amount of movement of the non-fixed bearing ring when the bearing is still to be installed in the shaft or housing. As **Figure 1** shows, either the inner ring or outer ring is fixed and the amount of movement in the radial or axial direction by the non-fixed bearing ring is the bearing internal clearance. Depending on the direction of movement, the clearance is referred to as either **radial internal clearance** or **axial internal clearance**.

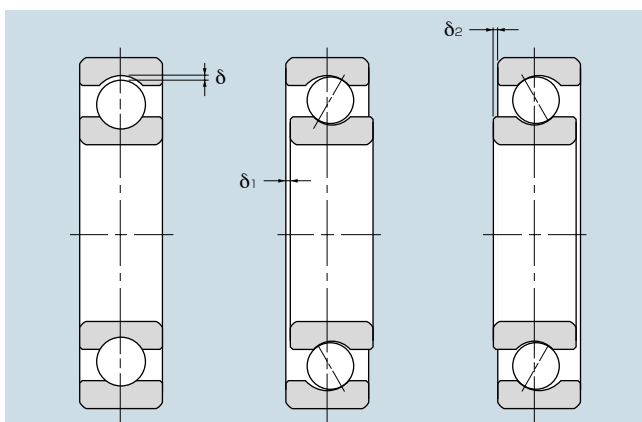

Radial internal clearance = δ Axial internal clearance = $\delta_1 + \delta_2$

Fig. 1 Bearing Internal Clearance

In order to accurately measure the bearing internal clearance, a measurement load is placed on the bearing ring. Therefore, the measured clearance value (measured clearance) will be larger than the true clearance by the amount of the elastic deformation caused by the measurement load. In order to calculate the true bearing internal clearance, the increase in the clearance caused by the elastic deformation must be corrected by using **Table 1**. This elastic deformation is small enough to be ignored for roller bearings.

Table 1 Radial Internal Clearance Compensation for Measurement Loads (Deep Groove Ball Bearings)

Nominal bore diameter mm	Measurement load N (kgf)	Internal clearance correction						
		over		incl.				
		C2	CN	C3	C4	C5		
10 (included)	18	24.5	{2.5}	3~4	4	4	4	4
18	50	49	{5}	4~5	5	6	6	6
50	200	147	{15}	6~8	8	9	9	9

1.4.1 Internal clearance selection

The internal clearance of a bearing under operating conditions (operating clearance) is **usually smaller** than the initial clearance of the same bearing before being installed and operated. This is due to several factors, including bearing fit, difference in temperature between the inner and outer rings, etc. As the operating clearance of a bearing has an effect on bearing life, heat generation, vibration and noise, care must be taken in selecting the most suitable operating clearance.

<Criteria for selecting bearing internal clearance>

In theory, the life of a bearing is at longest when the operating clearance is slightly negative in steady operation. However, in reality it is difficult to constantly maintain this optimum condition. If the negative clearance is enlarged by fluctuating operating conditions, heat will be produced and life will decrease dramatically. Therefore, under normal conditions **an internal clearance slightly larger than zero should be selected as the operating clearance.**

For normal operating conditions (i.e., when normal load fitting is used, and the rotational speed, operating temperature and other factors are normal), an appropriate operating clearance can be achieved by selecting a normal clearance.

Table 2 shows examples of applying internal clearances other than CN (normal) clearance.

Table 2 Examples of Applications Where Bearing Clearances Other Than CN (Normal) Clearance Are Used

Operating conditions	Applications	Selected clearance
With heavy or shock load, clearance is large.	Railway car axles	C3
	Vibration screens	C3, C4
With indeterminate load, both inner and outer rings are tight-fitted.	Railway car traction motors	C4
	Tractors and final speed regulators	C4
Shaft or inner ring is heated.	Paper making machines and driers	C3, C4
	Rolling mill table rollers	C3
Reduction of noise and vibration when rotating.	Micromotors	C2, CM
Adjustment of clearance to minimize shaft runout.	Main spindles of lathes (Double-row cylindrical roller bearings)	C9NA, C0NA
Loose fitting for both inner and outer rings.	Compressor roll neck	C2

1.4.2 Calculating of operating clearance

The operating clearance of a bearing can be calculated from the initial bearing internal clearance and decrease in internal clearance due to interference and decrease in internal clearance due to the difference in temperature between the inner and outer rings.

$$\delta_{\text{eff}} = \delta_o - (\delta_f + \delta_t) \quad (1)$$

- δ_{eff} : Operating clearance, mm
- δ_o : Bearing internal clearance, mm
- δ_f : Reduced amount of internal clearance due to interference, mm
- δ_t : Reduced amount of internal clearance due to temperature differential of inner and outer rings, mm

(1) Reduced internal clearance due to interference

When bearings are installed with interference fixed on shafts and in housings, the inner ring will expand and the outer ring will contract, **thereby reducing the internal clearance of the bearings.**

The amount of expansion or contraction varies depending on the shape of the bearing, the shape of the shaft or housing, and the dimensions and materials of the parts, but the differential ranges from approximately **70 to 90 percent of the effective interference.**

$$\delta_f = (0.70 \sim 0.90) \Delta d_{\text{eff}} \quad (2)$$

δ_f : Reduced amount of internal clearance due to interference, mm

Δd_{eff} : Effective interference, mm

(2) Reduced internal clearance due to inner/outer ring temperature differences

During operation, the outer ring will normally range from 5 to 10°C cooler than the inner ring or rotating parts. However, if the cooling effect of the housing is large, the shaft is connected to a heat source, or a heated substance is conducted through a hollow shaft, the temperature difference between the two rings can be even greater. **The amount of internal clearance is thus further reduced by the expansion differential of the two rings.**

$$\delta_t = \alpha \cdot \Delta T \cdot D_o \quad (3)$$

δ_t : Reduced amount of internal clearance due to temperature differential of inner and outer rings, mm

α : Bearing material expansion coefficient $12.5 \times 10^{-6} / ^\circ\text{C}$

ΔT : Inner/outer ring temperature differential, °C

D_o : Outer ring raceway diameter, mm

The outer ring raceway diameter D_o can be approximated by using equations (4) and (5).

For ball bearings and spherical roller bearings,

$$D_o = 0.20 (d + 4.0D) \quad (4)$$

For roller bearings (except spherical roller bearings),

$$D_o = 0.25 (d + 3.0D) \quad (5)$$

d : Bearing bore diameter, mm

D : Bearing outer diameter, mm

Table 3 Radial Internal Clearance of Deep Groove Ball Bearings

Units: μm

Nominal bore diameter d mm	C2		CN		C3		C4		C5	
	over	incl.	min	max	min	max	min	max	min	max
—	2.5		0	6	4	11	10	20	—	—
2.5	6		0	7	2	13	8	23	—	—
6	10		0	7	2	13	8	23	14	29
10	18		0	9	3	18	11	25	18	33
18	24		0	10	5	20	13	28	20	36
24	30		1	11	5	20	13	28	23	41
30	40		1	11	6	20	15	33	28	46
40	50		1	11	6	23	18	36	30	51
50	65		1	15	8	28	23	43	38	61

Table 4 Radial Internal Clearance of Miniature and Extra Small Ball Bearings (bore diameter $\phi d < 10$ mm)

Units: μm

MIL standard	Tight				Standard				Loose		Extra Loose	
Symbol	C2S		CNS		CNM		CNL		C3S		C3M	
Internal clearance	min	max	min	max	min	max	min	max	min	max	min	max
		0	5	3	8	5	10	8	13	10	15	13

Note 1) These standards are specified in accordance with MIL 23063. However, NTN codes are shown.

2. High-temperature, Long-life Bearings



NTN high-temperature, long-life bearings for fixed locations combine low price with long life by using a special high-temperature, long-life grease that was developed by NTN.

2.1 Recommended grease by operating temperature

Operating temperature range	NTN grease code	NTN grease name
~180°C	L353	J
~220°C	LX90	N-1
~260°C	LY08	EF-3

2.2 Typical qualities of the recommended grease

NTN grease code	L353	LX90	LY08
NTN grease name	J	N-1	EF-3
Base oil	Ester oil	Fluorine oil	Fluorine oil
Thickener	Urea	PTFE	PTFE
Worked penetration, NLGI	1~2	2	2
Drop point	280 or greater	None	None
Oil separation point, 100×24h	—	6.0	5.3

2.3 High temperature durability test data for grease

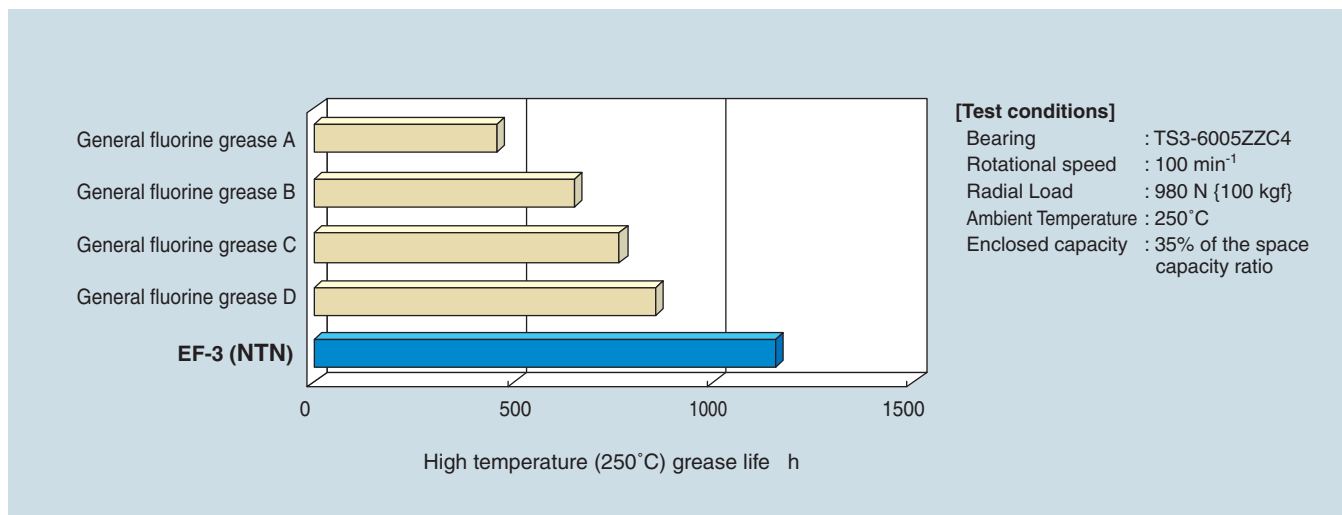

2.4 Compatible bearing sizes

If heat resistance specifications are used*, there is no limit to the bearing size.

*

Operating temperature range	Heat-resistant processing code
~160°C	TS2
~200°C	TS3
~250°C	TS4

3. Conductive Bearings



3.1 The need for conductivity

One of the properties required of bearings for office equipment is electric conductivity. One method for making bearings conductive is to enclose them in electro-conductive grease, and the conductive properties of bearings is greatly affected by the properties of the grease.

In recent years, because of the needs for improved image quality and reduced electromagnetic static, and the needs for simpler mechanisms, there is a strong demand for improved electro-conductivity in bearings.

3.2 NTN electro-conductive grease

In order to meet the above needs, NTN has developed electro-conductive grease for bearings to be used in photosensitive drum units and fusing units, and these bearings have been used by many customers.

It should be noted that all NTN electro-conductive grease is chemical attack preventing. (See the section on chemical attack preventing bearings for details.)

3.3 Recommended grease brands by operating

Operating temperature range	NTN grease code	NTN grease name
~70°C	L745	EP-3
120°C~	LY47	EF-7

3.4 Typical qualities of recommended grease

NTN grease code	L745	LY47
NTN grease name	EP-3	EF-7
Base oil	PAO	Fluorine oil
Thickener	Electro-conductive substance Lithium	Electro-conductive substance
Worked penetration, NLGI	2	3
Drop point	260 or greater	None
Oil separation point, 100×24h	1.6	0.5
Features	Chemical attack preventing	Chemical attack preventing

3.5 Compatible bearing sizes

Electro-conductivity is assured by the use of electro-conductive grease, so that there is no limit to the size of bearings.

3.6 Electro-conductivity performance evaluation data

The following shows the measured resistance data for bearings with the grease on the left encapsulated.

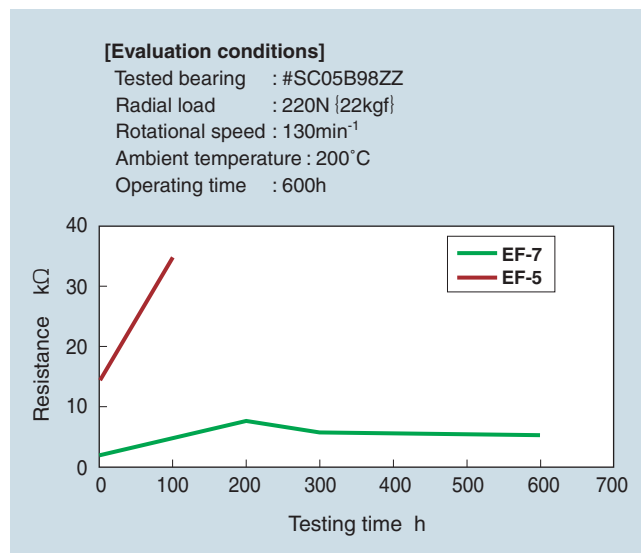
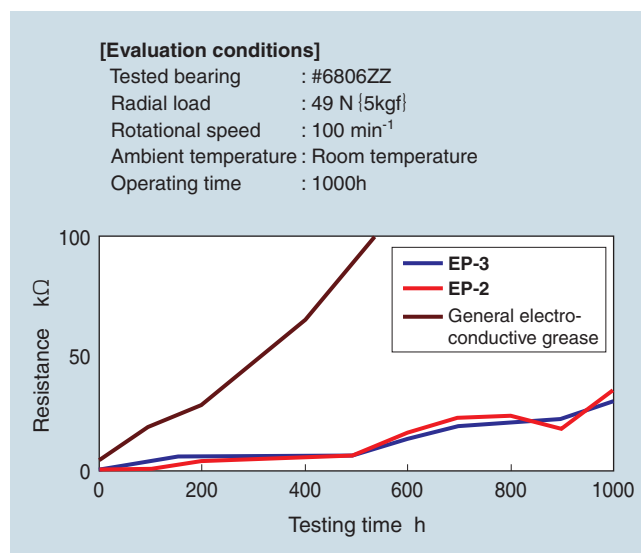

4. Chemical Attack Preventing Bearings

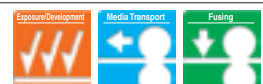

4.1 Chemical attack

Because office equipment is using more resins, there are many resin parts surrounding the bearings. Bearings use many types of oils for lubrication and corrosion resistance, and, in recent years, these oils have led to breaking (**Photo 1**) and cracking (**Photo 2**) of resin parts.

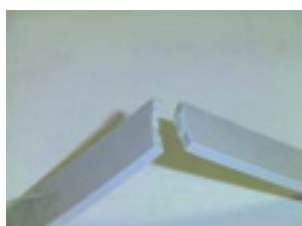

Photo 1 Breaking (PC-ABS)



Photo 2 Cracks (PC)

4.2 NTN chemical attack preventing bearings

NTN has developed special oils (greases and corrosion preventing oils) that have minimal affect on the resins used in office equipment, and these are widely used.

4.3 Typical qualities of grease used in NTN chemical attack preventing bearings

NTN grease code	L542	LX90	LY08	L745	LY47
NTN grease name	EP-1	N-1	EF-3	EP-3	EF-7
Operating temperature range	~180°C	~220°C	~260°C	~70°C	~250°C
Base oil	PAO	Fluorine oil	Fluorine oil	PAO	Fluorine oil
Thickener	Urea	PTFE	PTFE	Electro-conductive substance Lithium	Electro-conductive substance
Worked penetration, NLGI	3	2	2	2	3
Drop point	260 or greater	None	None	230 or greater	None
Oil separation point, 100°C× 24h	0.4	6.0	5.3	1.6	0.5
Features	Non-conductive grease			Electro-conductive grease	

4.4 Chemical attack performance evaluation data

NTN grease code (NTN grease name)	Resin material							
	ABS	PC	PC+ABS	POM	PA	PBT	PEEK	PPS
① L353 (J)	×	×	×	○	○	○	○	○
② LX90 (N-1)	○	○	○	○	○	○	○	○
③ L542 (EP-1)	○	○	○	○	○	○	○	○
④ L745 (EP-3)	○	○	○	○	○	○	○	○
⑤ LY08 (EF-3)	○	○	○	○	○	○	○	○
⑥ LY47 (EF-7)	○	○	○	○	○	○	○	○

※ ○: No attack, ×: Attacks

※ Typical samples of the above resins were used (i.e., generally available resins).

※ Bearings ② through ⑥ use chemical attack preventing grease.

4.5 Chemical attack preventing corrosion preventing oils

The corrosion preventing oil used in NTN chemical attack preventing bearings is a specially developed oil. (It has been confirmed that this oil will not attack the resins listed above.)

4.6 Compatible bearing sizes

Compatible with all bearings regardless of size.

5. Integrated Rotation Sensor Bearings



5.1 Features

This integrated sensor bearing is an integrated product combining a bearing with a rotation sensor (rotary encoder). Integrated sensor bearings have the following features:

- Because assembly and adjustment processes can be shortened, they lead to lower costs.
- Installation space can be smaller (compact design).

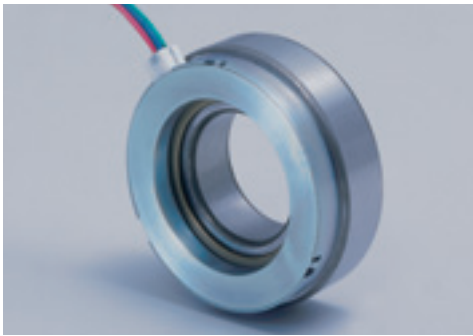

Photo 1 Appearance

5.2 Bearing models and pulses

Table 1 shows the relations between small diameter size bearing models (excluding bearing models with shaft diameter of 20 mm or greater) and pulses.

Table 1 Bearing Models and Pulses

Shaft diameter	Bearing model	Pulses	Output phases
15	6202	32	A, B
17	6203	32	A, B

※Please consult with us with regard to other bearing models.

5.3 Construction

Photo 1 shows the appearance of the 6206 type and Figure 1 shows its cross section. As the figure shows, a hall effect IC detects the changes in magnetic poles when a magnetic encoder with alternating N and S poles is rotated, and these changes are output as pulse signals. By installing two hall effect ICs at 90 degrees to one another, two phase output can be achieved allowing the detection of the rotational direction.

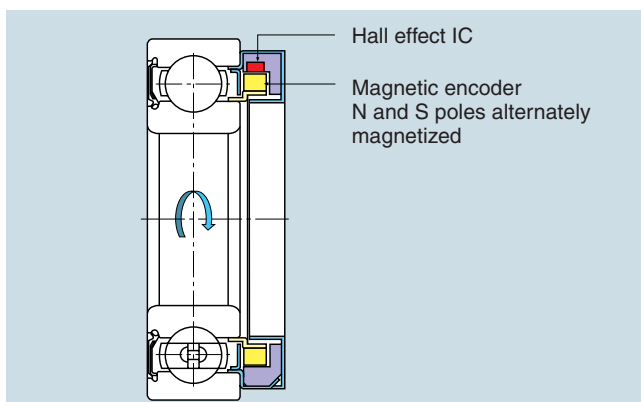

Fig. 1 Cross Section

5.4 Main specifications

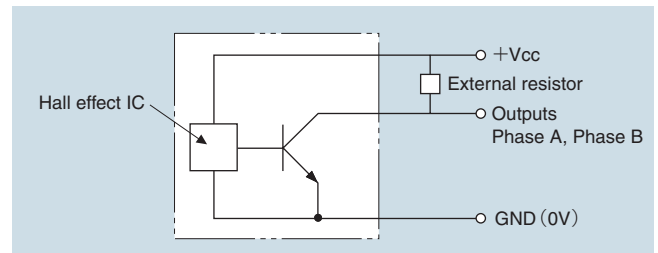

Fig. 2 Circuit Diagram

- ① Input voltage: 5 V to 24 V
- ② Output format: Open collector
- ③ Induced current: 20 mA or less
- ④ Output waveform: Rectangular waveform
- ⑤ Output pulses: See Table 1
- ⑥ Temperature range: -40°C to 120°C
- ⑦ Wire colors: See Table 2

Table 2 Wire Colors

Red	+Vcc
White	Phase A output
Blue	Phase B output
Black	Ground (0 V)

5.5 Output accuracy

Definition of output accuracy

The definition of output accuracy is given below. (Fig. 3)

- ① Proximity pitch error (%) = $\frac{|(T_n - T_{n+1})|}{T_n} \times 100$ (n=1,2,3...)
- ② Duty ratio (%) = $T_p / T_n \times 100$
- ③ Phase A and B timing (angle) = $T_{AB} / T_n \times 360$

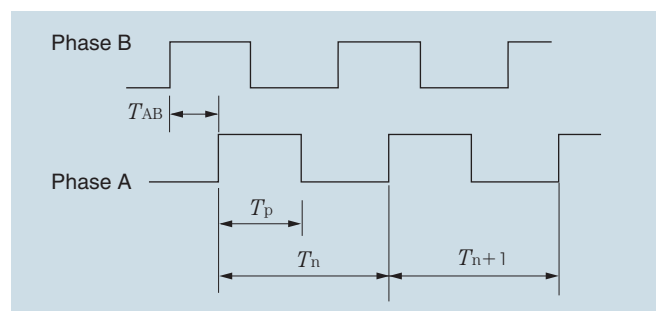

Fig. 3 Definition of Output Accuracy

5.6 Standards (tentative) for degree of Phase A and Phase B output accuracy

- ① Proximity pitch error (%) = 5% or less
- ② Duty ratio (%) = 50% ± 15%
- ③ Phase A and B timing (angle) = 90 degrees ± 45 degrees

5.7 Uses

Rotational angle detection mechanism (paper feeder units, photoconductive drum units)

*** Do not use these bearings in areas where human life depends on them.**

6. Thin-type Ball Bearings (Series 67)



In order to meet the needs for more compact and lighter office equipment, we supply the Series 67 thin-type ball bearings that have smaller bearing cross section dimensions than the Series 68 deep-groove ball bearings. In addition, design can be optimized for sealed bearings and models with snap rings.

6.1 Features of Series 67

- Series 67 are designed to be thinner than those of Series 68. (See Fig. 1.)
- Both open and non-contact sealed models (LLF) are available. (See Fig. 2.)
Furthermore, shield models (ZZ) are compatible with bores of $\phi 12$, $\phi 15$, $\phi 20$, $\phi 25$ and $\phi 30$.
- These bearings can be made compatible with snap rings. (See Fig. 3.)
- The dimensional accuracy and rotation accuracy meet JIS class 0 standards.
- Open models have seal grooves on their outer ring (except for the 6700).
- The inner rings do not have seal grooves.

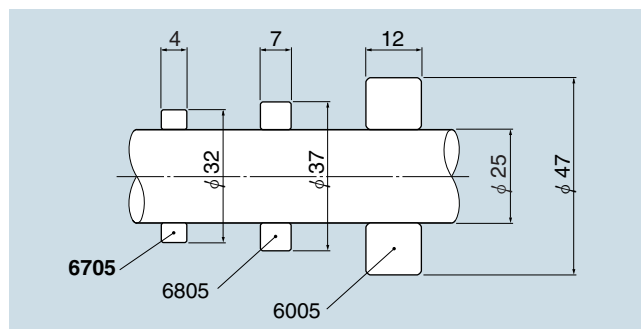

Fig. 1 Comparison of Cross Section Dimensions

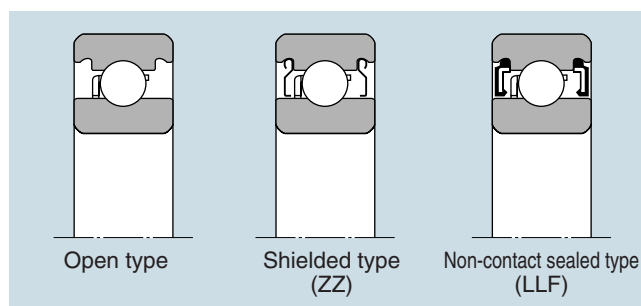
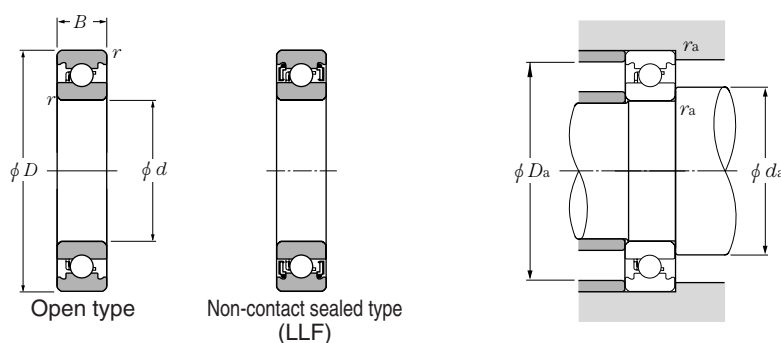

Fig. 2 Shapes of Series 67

6.2 Series 67 dimension table



Dynamic equivalent radial load
 $P_r = X F_r + Y F_a$

$\frac{f_0 \cdot F_a}{C_{or}}$	e	$\frac{F_a}{F_r} \leq e$		$\frac{F_a}{F_r} > e$	
		X	Y	X	Y
0.172	0.19				2.30
0.345	0.22				1.99
0.689	0.26				1.71
1.03	0.28				1.55
1.38	0.30	1	0	0.56	1.45
2.07	0.34				1.31
3.45	0.38				1.15
5.17	0.42				1.04
6.89	0.44				1.00

Static equivalent radial load

$$P_{or} = 0.6 F_r + 0.5 F_a$$

However, when $P_{or} < F_r$, then make $P_{or} = F_r$.

Main dimensions mm				Basic dynamic rated load N	Basic static rated load kgf	Coefficient f_0	Model numbers			Allowed rotational speed min^{-1} Grease lubrication open types ZZ, LLF	Installation dimensions mm				Mass kg (Reference)		
d	D	B	$r_s \text{ min}$	C_r	C_{or}		C_r	Open type	Shielded type		Non-contact sealed type	d_a min	d_a max	r_{as} max			
10	15	3	0.1	855	435	87	44	15.7	6700	—	—	34 000	10.8	11.5	14.2	0.1	0.0014
	15	4	0.1	855	435	87	44	15.7	—	—	W6700LLF	34 000	10.8	11.5	14.2	0.1	0.0021
12	18	4	0.2	930	530	95	54	16.2	6701	6701ZZ	6701LLF	31 000	13.1	13.8	16.4	0.2	0.0026
15	21	4	0.2	940	585	96	59	16.5	6702	6702ZZ	6702LLF	28 000	16.1	16.8	19.4	0.2	0.003
17	23	4	0.2	1 000	660	102	67	16.3	6703	—	6703LLF	26 000	18.1	18.8	21.4	0.2	0.0039
20	27	4	0.2	1 040	730	106	74	16.1	6704	6704ZZ	6704LLF	23 000	21.6	22.3	25.4	0.2	0.0057
25	32	4	0.2	1 100	840	112	86	15.8	6705	6705ZZ	6705LLF	20 000	26.6	27.3	30.4	0.2	0.0068
30	37	4	0.2	1 140	950	117	97	15.7	6706	6706ZZ	6706LLF	16 000	31.6	32.3	35.4	0.2	0.0081

① Minimum allowed dimensions for chamfer dimension r

6.3 Dimension table of sealed, thin-type ball bearings with snap rings

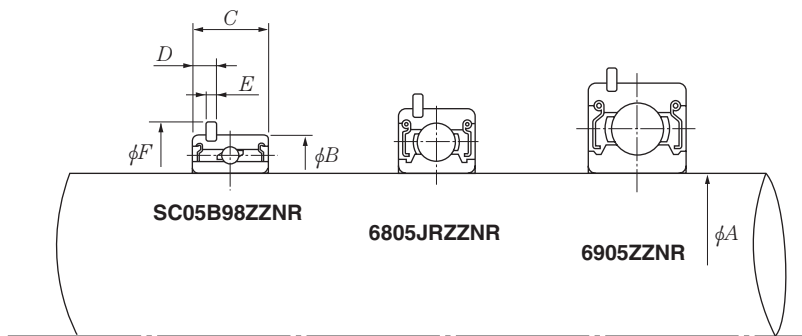

Fig. 3

Name	Internal design	(Bore × outer diameter × width)			Snap ring groove location D	Snap ring dimensions	
		A	B	C		E	F (最大)
SC04C21ZZNR	6704	20	27	7	1.3	0.85	29.7
SC05B98ZZNR	6705	25	32	7	1.3	0.85	34.46
SC06C28ZZNRX2	6706	30	37	7	1.3	0.85	39.5
SC07B06ZZNR	6707	35	44	6.5	1.65	0.85	46.8

<Reference>

Name	(Bore × outer diameter × width)			Snap ring groove location D	Snap ring dimensions	
	A	B	C		E	F (max)
6804	20	32	7	1.3	0.85	34.8
6904	20	37	9	1.7	0.85	39.8
6805	25	37	7	1.3	0.85	39.8
6905	25	42	9	1.7	0.85	44.8

6.4 Bearings with insulation sleeves

We can also make bearings with insulation sleeves. In addition, we can also make electro-conductive specification models.



7. Miniature and Extra Small Ball Bearings

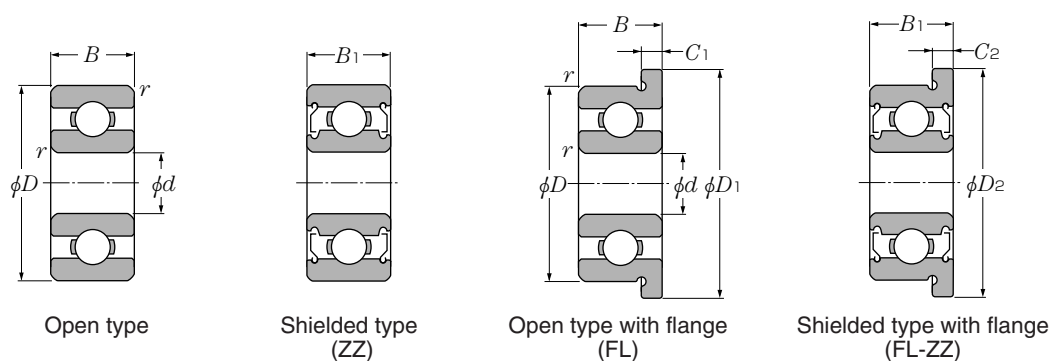

d 4~8mm

d	Main dimensions mm								Basic dynamic rated load N	Basic static rated load kgf	Coefficient f_0	Allowed rotational speed min^{-1}			
	D	B	B ₁	D ₁	D ₂	C ₁	C ₂	r_s min ^①				C _r	C _{or}	Grease lubrication	Oil lubrication
4	7	2	2.5	8.2	8.2	0.6	0.6	0.08	222	88.0	23.0	9.00	15.3	54 000	63 000
	8	2	3	9.2	9.2	0.6	0.6	0.08	395	140	40.0	14.0	13.9	52 000	61 000
	9	2.5	4	10.3	10.3	0.6	1	0.15	640	224	65.0	23.0	12.7	49 000	57 000
	10	3	4	11.2	11.6	0.6	0.8	0.15	650	235	66.0	24.0	13.3	46 000	55 000
	11	4	4	12.5	12.5	1	1	0.15	715	276	73.0	28.0	13.7	45 000	52 000
	12	4	4	13.5	13.5	1	1	0.2	970	360	99.0	36.0	12.8	43 000	51 000
	13	5	5	15	15	1	1	0.2	1 310	490	134	50.0	12.4	42 000	49 000
	16	5	5	—	—	—	—	0.3	1 760	680	179	69.0	12.4	37 000	44 000
5	8	2	2.5	9.2	9.2	0.6	0.6	0.08	217	91.0	22.0	9.50	15.8	49 000	57 000
	9	2.5	3	10.2	10.2	0.6	0.6	0.15	500	211	51.0	21.0	14.6	46 000	55 000
	10	3	4	11.2	11.6	0.6	0.8	0.15	715	276	73.0	28.0	13.7	45 000	52 000
	11	3	5	12.5	12.5	0.8	1	0.15	715	282	73.0	29.0	14.0	43 000	51 000
	13	4	4	15	15	1	1	0.2	1 080	430	110	44.0	13.4	40 000	47 000
	13	—	5	—	15	—	1	0.2	1 080	430	110	44.0	13.4	40 000	47 000
	14	5	5	16	16	1	1	0.2	1 330	505	135	52.0	12.8	39 000	46 000
	16	5	5	18	18	1	1	0.3	1 760	680	179	69.0	12.4	37 000	44 000
	19	6	6	—	—	—	—	0.3	2 340	885	238	90.0	12.1	34 000	40 000
6	10	2.5	3	11.2	11.2	0.6	0.6	0.1	465	196	47.0	20.0	15.2	43 000	51 000
	12	3	4	13.2	13.6	0.6	0.8	0.15	830	365	85.0	37.0	14.5	40 000	47 000
	13	3.5	5	15	15	1.0	1.1	0.15	1 080	440	110	45.0	13.7	39 000	46 000
	15	5	5	17	17	1.2	1.2	0.2	1 350	530	137	54.0	13.3	37 000	44 000
	16	6	6	—	—	—	—	0.2	1 770	695	181	71.0	12.7	36 000	42 000
	17	6	6	19	19	1.2	1.2	0.3	2 190	865	224	88.0	12.3	35 000	42 000
	19	6	6	22	22	1.5	1.5	0.3	2 340	885	238	90.0	12.1	34 000	40 000
7	13	3	4	14.2	14.6	0.6	0.8	0.15	825	375	84.0	38.0	14.9	38 000	45 000
	14	3.5	5	16	16	1	1.1	0.15	1 170	505	120	51.0	14.0	37 000	44 000
	17	5	5	19	19	1.2	1.2	0.3	1 610	715	164	73.0	14.0	35 000	41 000
	19	6	6	—	—	—	—	0.3	2 240	910	228	93.0	12.9	34 000	40 000
	22	7	7	—	—	—	—	0.3	3 350	1 400	340	142	12.5	32 000	37 000
8	12	2.5	3.5	13.2	13.6	0.6	0.8	0.1	515	252	52.0	26.0	15.9	38 000	45 000
	14	3.5	4	15.6	15.6	0.8	0.8	0.15	820	385	84.0	39.0	15.2	36 000	43 000
	16	4	5	18	18	1	1.1	0.2	1 610	715	164	73.0	14.0	35 000	41 000
	19	6	6	22	22	1.5	1.5	0.3	1 990	865	202	88.0	13.8	33 000	39 000
	22	7	7	25	25	1.5	1.5	0.3	3 350	1 400	340	142	12.5	32 000	37 000
	24	8	8	—	—	—	—	0.3	4 000	1 590	410	162	11.7	31 000	36 000

① Minimum allowed dimensions for chamfer dimension r . ② Also applicable to models with flanges.

③ These dimensions are applicable to sealed and shield bearings.

Remarks: Refer to Cat. No. 2202/E "Ball and Roller Bearings" for the shaft diameters and dimensions of miniature and extra small ball bearings not listed above.

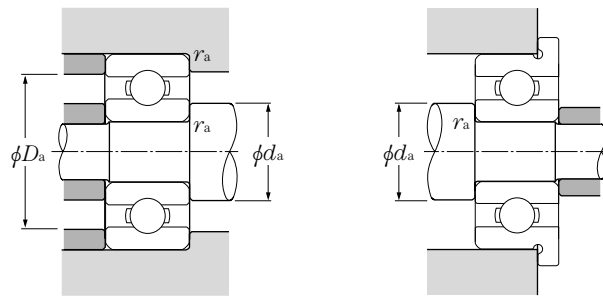

Dynamic equivalent radial load
 $P_r = X F_r + Y F_a$

$\frac{f_0 \cdot F_a}{C_{or}}$	e	$\frac{F_a}{F_r} \leq e$		$\frac{F_a}{F_r} > e$	
		X	Y	X	Y
0.172	0.19				2.30
0.345	0.22				1.99
0.689	0.26				1.71
1.03	0.28				1.55
1.38	0.30	1	0	0.56	1.45
2.07	0.34				1.31
3.45	0.38				1.15
5.17	0.42				1.04
6.89	0.44				1.00

Static equivalent radial load

$$P_{or} = 0.6 F_r + 0.5 F_a$$

However, when $P_{or} < F_r$, then make $P_{or} = F_r$.

Open type	Shielded type	Model number				Installation dimensions mm				Mass (reference) g		Models compatible with snap ring grooves and snap rings	
		Non-contact sealed type	Low torque sealed type	Contact sealed type	Open type with flange	Shielded type with flange	d_a min	d_a max	D_a max	r_{as} max	Open type		Open type with flange
674A	WA674ASSA	—	—	—	FL674A	FLWA674ASSA	4.6	5.0	6.4	0.08	0.28	0.35	
BC4-8	WBC4-8ZZ	—	—	—	FLBC4-8	FLWBC4-8ZZ	4.8	5.0	6.8	0.08	0.38	0.46	
684AX50	W684AX50ZZ	W684AX50LLF	—	W684AX50LL	FL684AX50	FLW684AX50ZZ	5.0	5.2	7.8	0.1	0.67	0.76	
BC4-10	WBC4-10ZZ	—	—	—	FLBC4-10	FLAWBC4-10ZZ	5.2	6.0	8.8	0.15	1	1.1	
694	694ZZ	—	—	—	FL694	FL694ZZ	5.2	6.4	9.8	0.15	1.8	2	
604	604ZZ	—	—	—	FL604	FL604ZZ	5.6	6.6	10.4	0.2	2.1	2.3	
624	624ZZ	624LLF	—	—	FL624	FL624ZZ	5.6	6.2	11.4	0.2	3.2	3.5	
634	634ZZ	—	—	—	—	—	6	7.6	14	0.3	5.1	—	
675	WA675ZZ	—	—	—	FL675	FLWA675ZZ	5.6	6.0	7.4	0.08	0.32	0.4	
BC5-9	WBC5-9ZZ	—	—	—	FLBC5-9	FLWBC5-9ZZ	5.2	6.1	7.8	0.15	0.55	0.63	
BC5-10	WBC5-10ZZ	—	—	—	FLBC5-10	FLAWBC5-10ZZ	6.2	6.4	8.8	0.15	0.88	0.97	
685	W685ZZ	—	—	—	FL685	FLW685ZZ	6.2	6.8	9.8	0.15	1.1	1.3	
695	695ZZ	695LLB	—	—	FL695	FL695ZZ	6.6	6.9	11.4	0.2	2.4	2.7	○
—	WBC5-13ZZ	—	—	—	—	FLWBC5-13ZZ	6.6	6.9	11.4	0.2	3.4	3.7	○
605	605ZZ	605LLB	—	—	FL605	FL605ZZ	6.6	7.4	12.4	0.2	3.5	3.9	○
625	625ZZ	625LLB	—	625LLU	FL625	FL625ZZ	7	7.6	14	0.3	4.8	5.2	
635	635ZZ	635LLB	—	635LLU	—	—	7	9.5	17	0.3	8	—	
676A	WA676AZZ	WA676ALLF	—	WA676ALL	FL676A	FLWA676AZZ	6.6	6.7	9.2	0.1	0.65	0.74	
BC6-12	WBC6-12ZZ	—	—	WBC6-12LL	FLBC6-12	FLAWBC6-12ZZ	7.2	7.9	10.8	0.15	1.3	1.4	○
686	W686ZZ	W686LLB	—	W686LLX	FL686	FLW686ZZ	7.0	7.2	11.8	0.15	1.9	2.2	○
696	696ZZ	696LLB	—	696LLU	FL696	FL696ZZ	7.6	7.8	13.4	0.2	3.8	4.3	○
BC6-16A	BC6-16AZZ	—	—	—	—	—	7.6	8.0	14.4	0.2	5.2	—	
606	606ZZ	606LLB	606LLH	606LLU	FL606	FL606ZZ	8	8.6	15	0.3	6	6.5	
626	626ZZ	626LLB	—	626LLU	FL626	FL626ZZ	8	9.5	17	0.3	8.1	9.2	○
BC7-13	WBC7-13ZZ	—	—	—	FLBC7-13	FLAWBC7-13ZZ	8.2	8.9	11.8	0.15	1.4	1.5	
687A	W687AZZ	—	—	—	FL687A	FLW687AZZ	8.2	8.7	12.8	0.15	2.1	2.4	
697	697ZZ	—	—	697LLU	FL697	FL697ZZ	9	10.0	15	0.3	5.2	5.7	
607	607ZZ	607LLB	—	607LLU	—	—	9	10.4	17	0.3	8	—	
627	627ZZ	627LLB	627LLHX	627LLU	—	—	9	12.2	20	0.3	13	—	
678A	W678AZZ	—	—	—	FL678A	FLAW678AZZ	8.8	9.1	11.2	0.1	0.75	0.86	
BC8-14	WBC8-14ZZ	WBC8-14LLF	—	WBC8-14LL	FLBC8-14	FLWBC8-14ZZ	9.2	9.5	12.8	0.15	1.8	1.9	
688A	W688AZZ	W688ALLB	—	W688ALLU	FL688A	FLW688AZZ	9.6	10.0	14.4	0.2	3.1	3.5	○
698	698ZZ	698LLB	—	698LLU	FL698	FL698ZZ	10	10.6	17	0.3	7.3	8.4	○
608	608ZZ	608LLB	608LLHX	608LLU	FL608MU	FL608MZZ	10	12.2	20	0.3	12	13	○
628	628ZZ	628LLB	628LLH	628LLU	—	—	10	12.1	22	0.3	17	—	

④ Shows the values for double shielded bearings. ⑤ See page 18. ⑥ Also compatible with steel plate shields. ⑦ The internal specifications differ.

8. Deep Groove Ball Bearings

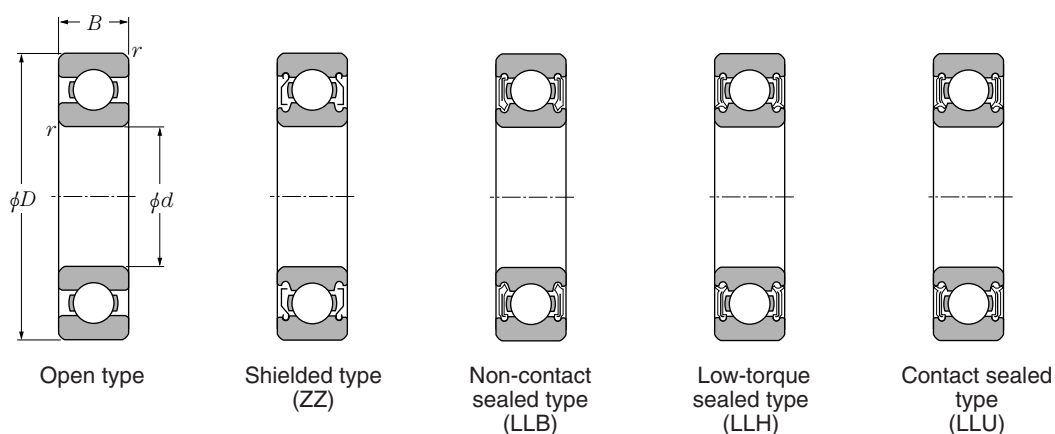
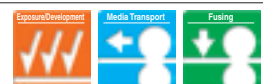

d 10~45mm

d	Main dimensions mm				Basic dynamic rated load		Basic static rated load		Coefficient f_0	Allowed rotational speed min^{-1}				Model number				
	D	B	r_s min	r_{Ns} min	C_r kN	C_{Or} kN	C_r kgf	C_{Or} kgf		Grease lubrication, open type ZZ LLB	Oil lubrication, open type ZZ LLB	LLH	LLU	Open type	Shielded type	Non-contact sealed type	Low-torque sealed type	Contact sealed type
10	19	5	0.3	—	1.83	0.925	187	94	14.8	32 000	38 000	—	24 000	6800	ZZ	LLB	—	LLU
	22	6	0.3	0.3	2.7	1.27	275	129	14.0	30 000	36 000	25 000	21 000	6900	ZZ	LLB	LLH	LLU
	26	8	0.3	—	4.55	1.96	465	200	12.4	29 000	34 000	25 000	21 000	6000	ZZ	LLB	LLH	LLU
12	21	5	0.3	—	1.92	1.04	195	106	15.3	29 000	35 000	—	20 000	6801	ZZ	LLB	—	LLU
	24	6	0.3	0.3	2.89	1.46	295	149	14.5	27 000	32 000	22 000	19 000	6901	ZZ	LLB	LLH	LLU
	28	8	0.3	—	5.10	2.39	520	244	13.2	26 000	30 000	21 000	18 000	6001	ZZ	LLB	LLH	LLU
15	24	5	0.3	—	2.08	1.26	212	128	15.8	26 000	31 000	—	17 000	6802	ZZ	LLB	—	LLU
	28	7	0.3	0.3	3.65	2.00	375	204	14.8	24 000	28 000	18 000	16 000	6902	ZZ	LLB	LLH	LLU
	32	9	0.3	0.3	5.60	2.83	570	289	13.9	22 000	26 000	18 000	15 000	6002	ZZ	LLB	LLH	LLU
	35	11	0.6	0.5	7.75	3.60	790	365	12.7	19 000	23 000	18 000	15 000	6202	ZZ	LLB	LLH	LLU
17	26	5	0.3	—	2.23	1.46	227	149	16.1	24 000	28 000	18 000	15 000	6803	ZZ	LLB	LLH	LLU
	30	7	0.3	0.3	4.65	2.58	475	263	14.7	22 000	26 000	—	14 000	6903	ZZ	LLB	—	LLU
	35	10	0.3	0.3	6.80	3.35	695	345	13.6	20 000	24 000	16 000	14 000	6003	ZZ	LLB	LLH	LLU
	40	12	0.6	0.5	9.60	4.60	980	465	12.8	18 000	21 000	15 000	12 000	6203	ZZ	LLB	LLH	LLU
20	32	7	0.3	0.3	4.00	2.47	410	252	15.5	21 000	25 000	15 000	13 000	6804	ZZ	LLB	LLH	LLU
	37	9	0.3	0.3	6.40	3.70	650	375	14.7	19 000	23 000	14 000	12 000	6904	ZZ	LLB	LLH	LLU
	42	12	0.6	0.5	9.40	5.05	955	515	13.9	18 000	21 000	13 000	11 000	6004	ZZ	LLB	LLH	LLU
25	37	7	0.3	0.3	4.30	2.95	435	300	16.1	18 000	21 000	12 000	10 000	6805	ZZ	LLB	LLH	LLU
	42	9	0.3	0.3	7.05	4.55	715	460	15.4	16 000	19 000	11 000	9 800	6905	ZZ	LLB	LLH	LLU
	47	12	0.6	0.5	10.1	5.85	1 030	595	14.5	15 000	18 000	11 000	9 400	6005	ZZ	LLB	LLH	LLU
30	42	7	0.3	0.3	4.70	3.65	480	370	16.5	15 000	18 000	10 000	8 800	6806	ZZ	LLB	LLH	LLU
	47	9	0.3	0.3	7.25	5.00	740	510	15.8	14 000	17 000	10 000	8 400	6906	ZZ	LLB	LLH	LLU
35	47	7	0.3	0.3	4.90	4.05	500	410	16.4	13 000	16 000	—	7 600	6807	ZZ	LLB	—	LLU
	55	10	0.6	0.5	9.55	6.85	975	695	15.8	12 000	15 000	8 500	7 100	6907	ZZ	LLB	LLH	LLU
40	52	7	0.3	0.3	5.10	4.40	520	445	16.3	12 000	14 000	8 000	6 700	6808	ZZ	LLB	LLH	LLU
	62	12	0.6	0.5	12.2	8.90	1 240	910	15.8	11 000	13 000	7 500	6 300	6908	ZZ	LLB	LLH	LLU
45	58	7	0.3	0.3	5.35	4.95	550	500	16.1	11 000	12 000	—	5 900	6809	ZZ	LLB	—	LLU
	68	12	0.6	0.5	13.1	10.4	1 330	1 060	16.1	9 800	12 000	6 700	5 600	6909	ZZ	LLB	LLH	LLU

① Minimum allowed dimensions for chamfer dimension r .

Remarks: Refer to Cat. No. 2202/E "Ball and Roller Bearings" for the shaft diameters and dimensions of deep groove ball bearings not listed above.

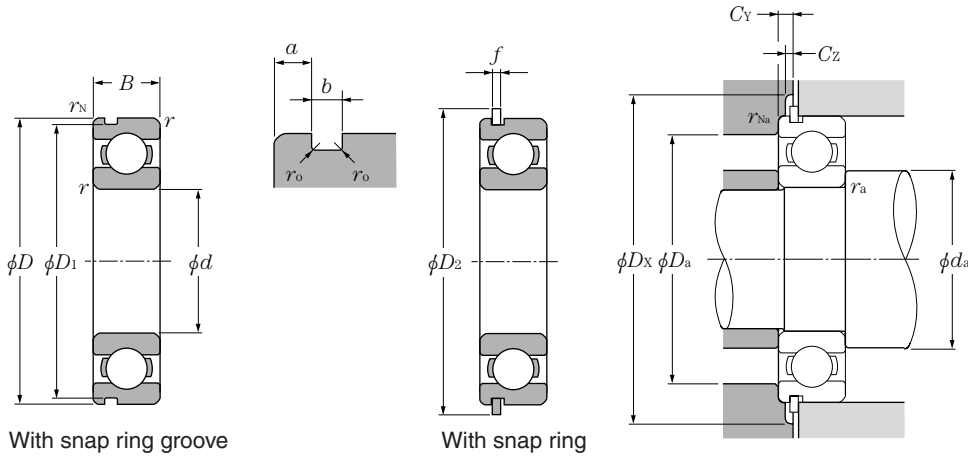

Dynamic equivalent radial load
 $P_r = X F_r + Y F_a$

$\frac{f_0 \cdot F_a}{C_{or}}$	e	$\frac{F_a}{F_r} \leq e$		$\frac{F_a}{F_r} > e$	
		X	Y	X	Y
0.172	0.19				2.30
0.345	0.22				1.99
0.689	0.26				1.71
1.03	0.28				1.55
1.38	0.30	1	0	0.56	1.45
2.07	0.34				1.31
3.45	0.38				1.15
5.17	0.42				1.04
6.89	0.44				1.00

Static equivalent radial load
 $P_{or} = 0.6 F_r + 0.5 F_a$
 However, when $P_{or} < F_r$, then make $P_{or} = F_r$.

Model number	Snap ring groove dimensions mm				Snap ring dimensions mm		Installation dimensions mm							Mass kg	Models compatible with snap ring grooves and snap rings			
	With snap ring groove	With snap ring	D1 max	a max	b max	r0 max	D2 max	f max	min	da max	Da max	DX (Reference)	CY max			CZ min	ras max	rNas max
—	—	—	—	—	—	—	—	—	12	12.5	17	—	—	—	0.3	—	0.005	
N	NR	20.8	1.05	0.8	0.2	24.8	0.7	12	13	20	25.5	1.5	0.7	0.3	0.3	0.009		
—	—	—	—	—	—	—	—	12	13.5	24	—	—	—	0.3	—	0.019	○	
—	—	—	—	—	—	—	—	14	14.5	19	—	—	—	0.3	—	0.006	○	
N	NR	22.8	1.05	0.8	0.2	26.8	0.7	14	15	22	27.5	1.5	0.7	0.3	0.3	0.011		
NX2	NX2RX3	26.44	2.20	0.9	0.3	32.7	0.85	14	16	26	33.4	2.8	0.9	0.3	0.3	0.021		
—	—	—	—	—	—	—	—	17	17.5	22	—	—	—	0.3	—	0.007		
N	NR	26.7	1.3	0.95	0.25	30.8	0.85	17	17.5	26	31.5	1.9	0.9	0.3	0.3	0.016		
N	NR	30.15	2.06	1.35	0.4	36.7	1.12	17	19	30	37.5	2.9	1.2	0.3	0.3	0.03		
N	NR	33.17	2.06	1.35	0.4	39.7	1.12	19	20	31	40.5	2.9	1.2	0.6	0.5	0.045		
—	—	—	—	—	—	—	—	19	19.5	24	—	—	—	0.3	—	0.008	○	
N	NR	28.7	1.3	0.95	0.25	32.8	0.85	19	20	28	33.5	1.9	0.9	0.3	0.3	0.018		
N	NR	33.17	2.06	1.35	0.4	39.7	1.12	19	21	33	40.5	2.9	1.2	0.3	0.3	0.039		
N	NR	38.1	2.06	1.35	0.4	44.6	1.12	21	23	36	45.5	2.9	1.2	0.6	0.5	0.066		
N	NR	30.7	1.3	0.95	0.25	34.8	0.85	22	22.5	30	35.5	1.9	0.9	0.3	0.3	0.019		
N	NR	35.7	1.7	0.95	0.25	39.8	0.85	22	24	35	40.5	2.3	0.9	0.3	0.3	0.036		
N	NR	39.75	2.06	1.35	0.4	46.3	1.12	24	26	38	47	2.9	1.2	0.6	0.5	0.069		
N	NR	35.7	1.3	0.95	0.25	39.8	0.85	27	28	35	40.5	1.9	0.9	0.3	0.3	0.022		
N	NR	40.7	1.7	0.95	0.25	44.8	0.85	27	29	40	45.5	2.3	0.9	0.3	0.3	0.042		
N	NR	44.6	2.06	1.35	0.4	52.7	1.12	29	30.5	43	53.5	2.9	1.2	0.6	0.5	0.08		
N	NR	40.7	1.3	0.95	0.25	44.8	0.85	32	33	40	45.5	1.9	0.9	0.3	0.3	0.026		
N	NR	45.7	1.7	0.95	0.25	49.8	0.85	32	34	45	50.5	2.3	0.9	0.3	0.3	0.048		
N	NR	45.7	1.3	0.95	0.25	49.8	0.85	37	38	45	50.5	1.9	0.9	0.3	0.3	0.029		
N	NR	53.7	1.7	0.95	0.25	57.8	0.85	39	40	51	58.5	2.3	0.9	0.6	0.5	0.074		
N	NR	50.7	1.3	0.95	0.25	54.8	0.85	42	43	50	55.5	1.9	0.9	0.3	0.3	0.033		
N	NR	60.7	1.7	0.95	0.25	64.8	0.85	44	45	58	65.5	2.3	0.9	0.6	0.5	0.11		
N	NR	56.7	1.3	0.95	0.25	60.8	0.85	47	48	56	61.5	1.9	0.9	0.3	0.3	0.04		
N	NR	66.7	1.7	0.95	0.25	70.8	0.85	49	51	64	72	2.3	0.9	0.6	0.5	0.128		

② We also make sealed and shield bearing models. ③ These dimensions are applicable to sealed and shield bearings. ④ Excluding bearings with snap rings. ⑤ See page 18.

9. Bearings with Snap Ring Grooves and Snap Rings

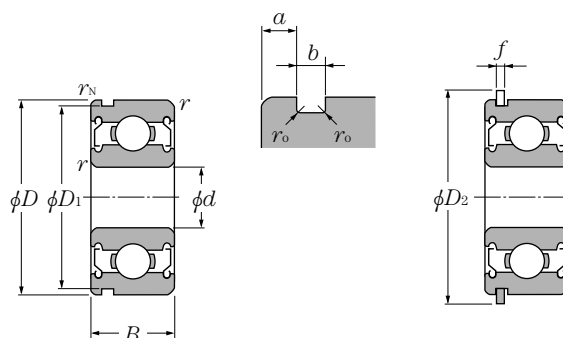

Snap ring groove, shielded type (ZZ)

Snap ring, shielded type (ZZ)

d 5~17mm

Main dimensions mm					Basic dynamic rated load N	Basic static rated load C_{or}	Basic dynamic rated load C_r kgf	Basic static rated load C_{or} kgf	Coefficient f_o	Allowed rotational speed min^{-1}		Model number				
d	D	B	r_s min	r_N min						Grease lubrication	Oil lubrication	Snap ring groove, shielded type	Snap ring, shielded type	Snap ring, non-contact shielded type	Snap ring, low-torque sealed type	Snap ring, contact sealed type
5	13	4	0.2	0.1	1 080	430	110	44	13.4	40 000	47 000	SC559ZZN	ZZNR	LLBNR	—	—
	14	5	0.2	0.2	1 330	505	135	52	12.8	39 000	46 000	SC571ZZN	ZZNR	LLBNR	—	—
6	12	4	0.15	0.1	640	365	65	37	14.5	40 000	47 000	*F-SC6A06ZZ1N	ZZ1NR	—	—	LLNR
	13	5	0.15	0.1	1 080	440	110	45	13.7	39 000	46 000	SC6A04ZZN	ZZNR	—	—	LLXNR
	15	5	0.2	0.2	1 350	530	137	54	13.3	37 000	44 000	SC6A17ZZN	ZZNR	LLBNR	—	LLUNR
	19	6	0.3	0.3	2 340	885	238	90	12.1	34 000	40 000	SC669ZZN	ZZNR	LLBNR	LLHNR	LLUNR
8	16	5	0.2	0.1	1 260	585	128	60	14.6	35 000	41 000	SC866ZZN	ZZNR	LLBNR	—	LLUNR
	19	6	0.3	0.3	1 990	865	202	88	13.8	33 000	39 000	SC8A91ZZN	ZZNR	LLBNR	—	LLUNR
	22	7	0.3	0.4	3 350	1 400	340	142	12.5	32 000	37 000	SC850ZZN	ZZNR	LLBNR	LLHNR	LLUNR
10	26	8	0.3	0.3	4 550	1 960	465	200	12.4	29 000	34 000	SC0039ZZN	ZZNR	LLBNR	LLHXNR	LLUNR
12	21	7	0.3	0.3	1 920	1 040	195	106	15.3	29 000	35 000	SC0189ZZN	ZZNR	LLBNR	—	LLUNR
17	26	5	0.3	0.3	2 230	1 460	227	149	16.1	24 000	28 000	SC03A04ZZN	ZZNR	LLBNR	LLHNR	LLUNR

① Minimum allowed dimensions for chamfer dimension r .

Remarks: Bearings with asterisks (*) next to their model number indicate stainless steel bearings.

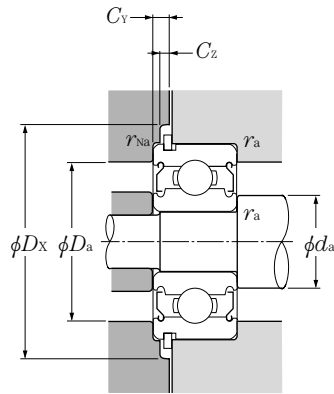

Dynamic equivalent radial load
 $P_r = XF_r + YF_a$

$\frac{f_0 \cdot F_a}{C_{or}}$	e	$\frac{F_a}{F_r} \leq e$		$\frac{F_a}{F_r} > e$	
		X	Y	X	Y
0.172	0.19				2.30
0.345	0.22				1.99
0.689	0.26				1.71
1.03	0.28				1.55
1.38	0.30	1	0	0.56	1.45
2.07	0.34				1.31
3.45	0.38				1.15
5.17	0.42				1.04
6.89	0.44				1.00

Static equivalent radial load
 $P_{or} = 0.6F_r + 0.5F_a$
 However, when $P_{or} < F_r$, then make $P_{or} = F_r$.

Snap ring groove dimensions mm				Snap ring dimensions mm		Installation dimensions mm							Mass kg	
D_1 max	a max	b min	r_0 max	D_2 max	f max	d_a min	d_a max	D_a max	D_X (Reference)	C_Y max	C_Z min	r_{as} max	r_{Nas} max	(Reference)
12.15	0.88	0.55	0.2	15.2	0.55	6.6	6.9	11.4	15.9	1.2	0.6	0.2	0.1	0.002
13.03	1.28	0.65	0.06	16.13	0.54	6.6	7.4	12.4	16.9	1.6	0.6	0.2	0.2	0.004
11.15	0.78	0.60	0.02	14.2	0.55	7.2	7.9	10.8	14.9	1.1	0.6	0.15	0.1	0.001
12.15	1.08	0.55	0.2	15.2	0.55	7.0	7.2	11.8	15.9	1.4	0.6	0.15	0.1	0.002
14.03	1.03	0.65	0.06	17.2	0.60	7.6	7.8	13.4	17.9	1.4	0.7	0.2	0.2	0.004
17.9	0.93	0.80	0.2	22.0	0.70	8.0	9.5	17.0	22.8	1.4	0.7	0.3	0.3	0.008
14.95	0.53	0.65	0.05	18.2	0.54	9.6	10.0	14.4	18.9	0.9	0.6	0.2	0.1	0.003
17.9	0.93	0.80	0.2	22.0	0.70	10.0	10.6	17	22.7	1.4	0.7	0.3	0.3	0.008
20.8	2.35	0.80	0.2	24.8	0.70	10.0	12.7	20	25.5	2.8	0.7	0.3	0.4	0.013
24.5	2.20	0.90	0.3	28.8	0.85	12	13.5	24	29.5	2.8	0.9	0.3	0.3	0.02
20.25	1.18	0.80	0.2	24.0	0.70	14	14.5	19	24.7	1.7	0.7	0.3	0.3	0.009
25.15	1.05	0.81	0.3	29.2	0.71	19	19.5	24	29.9	1.5	0.8	0.3	0.3	0.009



II Resin Products

1. Separating Pins	21
2. Separating Plates	21
3. Slide Bearings	22
4. Insulation Sleeves	22
5. Fusing Gears	23
6. Paper Output Parts (roller, rib)	23
7. Blades	24
8. Bearings for Cartridges	24
9. Bearing Units with Seals	25
10. BEAREE Selection Guidelines	26
11. Base Resins and Characteristics of Major Grades	27

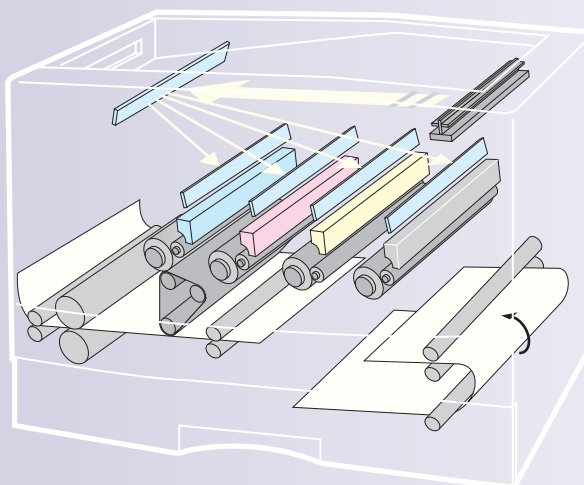

1. Separating Pins



Separating pins are used to separate paper from fusing rollers and pressure rollers.

The base material is very heat resistant a coating is applied that is toner resistant. This material can resist temperature distortion at operating temperatures from 200 to 230°C. Because of the wear resistance of the separating parts, the rollers are not damaged, either.

The tip is precision formed to a 0.05mm radius or smaller, ensuring reliable paper separation performance. In addition, NTN offers three (3) kinds of coating films for you to choose from so that you may be able to select one that is best suited to your application.

Processing : Injection molding, Coating



Separating pin material	Coating material	Operating temperature limit (guidelines)	Contact angle (vs. horizontal)
BEAREE AS5021 (material: PPS)	FE7030 (Color phase: Green) FE7031 (Color phase: Black)	230°C	95°
BEAREE PI5022 (material: PI)	FE7092	300°C (Crystallization treatment)	110°

*The larger the contact angle, the greater the resistance to becoming soiled by the toner.

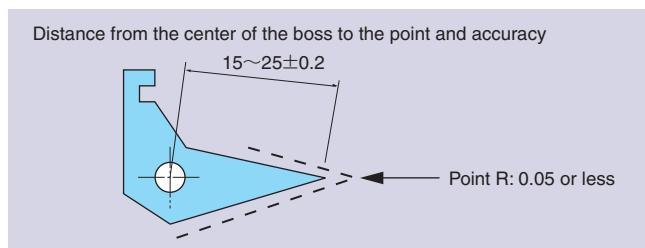

Fig. 1 Example of Typical Dimensions mm

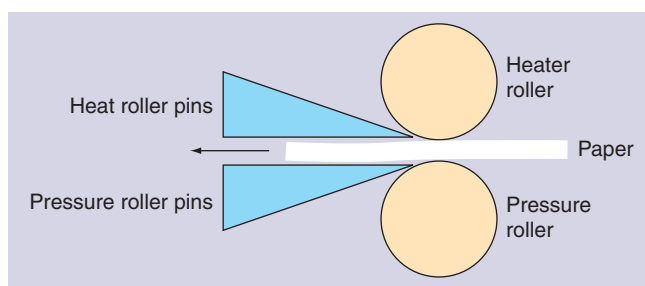

Fig. 2 Uses of Separating Pins

2. Separating Plates



Parts for paper guide that guides papers coming out of the transfer drum. In recent years, trends are away from use of jaws for paper separation and more and more separating plates are being employed in place of jaws for enhanced performance. We have two types of separating plates: film type and coating type.

Processing : See table below.

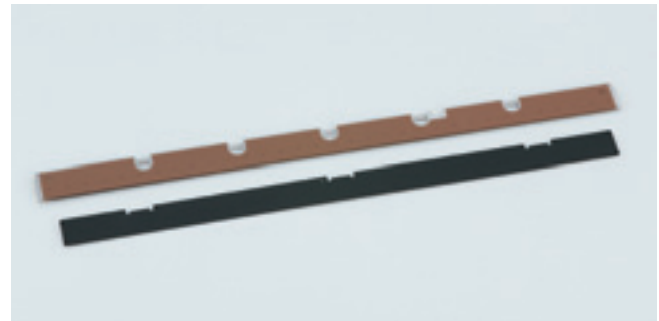

Type	Makeup	Processing
Film type	SUS plate, BEAREE FL9004	press forming, filming
Coating type	SUS plate, BEAREE FE7031	press forming, coating

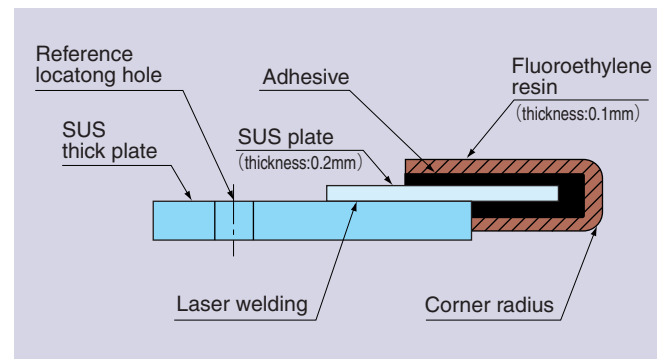

Fig. 1 Typical Film-type Separating Plates

- A 0.1mm thick filming on the edges eliminates local wears.
- It is of the design that a 0.2mm thick SUS plate extends close to the roller position, where the SUS plate is laser-welded to the thick SUS plate.

(Patent pending)

3. Slide Bearings



Slide bearings are used for fusing roller and pressure roller spindles, and they have excellent heat resistance, low friction coefficients and superior wear resistance.

Processing : Injection molding



4. Insulation Sleeves



Insulation sleeves are placed between heat rollers and roller bearings to prevent the transmitting of heat to the roller bearings. They are also used to prevent the rollers from discharging heat.

Insulation sleeves assure heat resistance and strength.

* Insulation sleeves can be sold in sets with roller bearings.

Processing : Injection molding



Table 1 Materials and Features

Material name	Properties		Features
	Operating temperature limit (guidelines)	Conductivity	
BEAREE AS5054 (PPS)	230°C	—	Low friction
BEAREE AS5962 (PPS)	230°C	○	Low friction and electro-conductive
BEAREE PI 5013 (Polyimide)	240°C	—	Low friction and high temperature atmosphere
BEAREE PI 5900 (Polyimide)	240°C	○	High temperature atmosphere and electro-conductive

Example of Typical Dimensions (mm)

Bearing bore: $\phi 6-\phi 40$

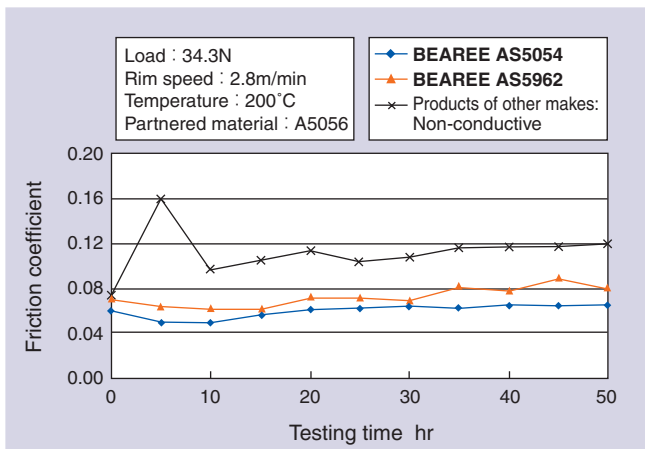

Fig. 1 Friction Coefficient in a High Temperature Radial Test

Table 1 Materials and Features

Material name	Properties				Features
	Operating temperature limit (guidelines)	Sliding	Strength	Conductivity	
BEAREE AS5040 (PPS)	230°C	—	◎	—	Strength
BEAREE AS5055 (PPS)	230°C	○	○	—	Noise measures
BEAREE AS5963 (PPS)	230°C	○	○	○	Noise measures and conductivity
BEAREE PI 5033 (Polyimide)	240°C	—	◎	—	High temperature atmosphere

Example of Typical Dimensions (mm)

Bore: $\phi 15-\phi 50$
Thickness: 1.5-3

Abutment shape

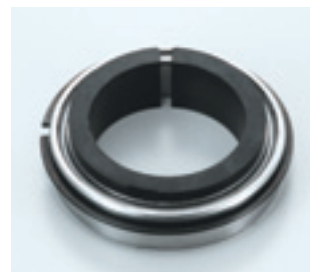

Bearing model number: 2TS3-SX05J11ZZ

Bearing with insulation sleeve

5. Fusing Gears



Fusing gears are injection molded gears used in higher temperature locations, such as fusing units.

These fusing gears are very strong, heat resistant and have long service lives.

NTN has various kinds of fusing gears for use as drive gears or planetary gears.

Processing : Injection molding



Table 1 Materials and Features

Material name	Properties			Main uses
	Operating temperature limit (guidelines)	Sliding	Strength	
BEAREE AI 5003 (Polyamideimide)	250°C	○	◎	Drive and idle gears
BEAREE PI 5033 (Polyimide)	240°C	—	◎	Drive gears
BEAREE AS5045 (PPS)	230°C	○	○	Drive and idle gears
BEAREE AS5040 (PPS)	230°C	—	◎	Drive gears

Table 2 Example of Typical Dimensions

Shape	Spur gears and helical gears
Module	0.8~1.5
Pitch circle diameter	15~60 mm

6. Paper Output Parts (roller, rib)



For the paper output parts that come into contact with pre-solidified toner on papers coming out past the transfer unit, adhesion-resistant special fluoroethylene resin materials are used to prevent toner from blotting papers.

Processing : Injection molding



Table 1 Materials and Features

Material name	Operating temperature limit (guidelines)	Contact angle (vs. horizontal)
BEAREE FE5000 (Hue: Transparent)	200°C	110°
BEAREE FE5001 (Hue: Black) (Characteristics of fluoroethylene)		
BEAREE FE5100 (Hue: White)	150°C	95°
BEAREE FE5101 (Hue: Gray) (Characteristics of fluoroethylene)		
General POM (material for comparison)	100°C	65°

* The larger the contact angle, the greater the resistance to becoming soiled by the toner.

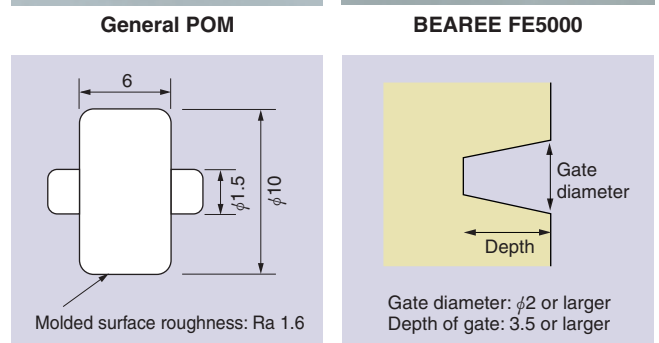
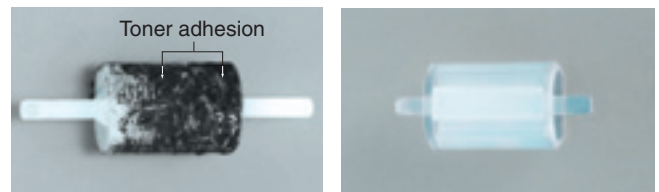

Fig. 1 Example of Typical Dimensions

Fig. 2 Gate Configuration for Paper Output Roller

7. Blades (Being Developed)



NTN manufactures the low-friction and highly wear-resistant **BEAREE ER3605** and **BEAREE ER3002** cleaning blade to remove unneeded toner from photoconductive drums.

The **BEAREE ER3605** and **BEAREE ER3002** are made from fluorine-containing rubber with a special additive to give it superior low friction and wear resistance properties.

The low friction characteristic prevents sticking and slipping, and because the design angle has been improved for greater range, these blades have superior cleaning ability.

Rubber material: **BEAREE ER3605**, **BEAREE ER3002**
 Processing : Press forming, high-accuracy shearing



Table 1 Friction Test Results

Test time: 60 minutes

Speed: 12 m

Opposing material: Polycarbonate

	Friction coefficient μ
Urethane	0.9
BEAREE ER3605 (Fluoroethylene-based material)	0.6
BEAREE ER3002 (Fluoroethylene-based material)	0.5

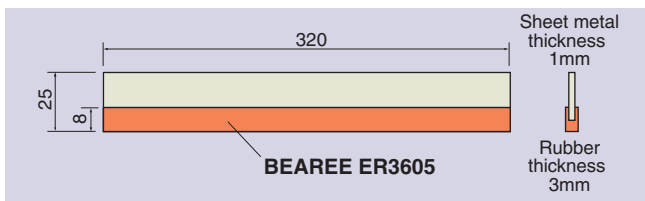

Fig. 1 Example of Typical Dimensions

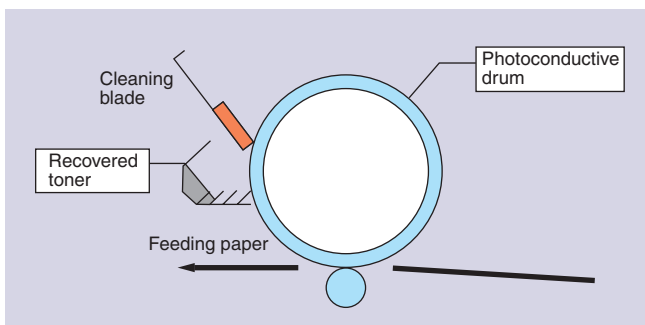

Fig. 2 Example of Use with a Photoconductive Drum

8. Bearings for Cartridges



The bearings enjoy superiority in terms of low friction coefficient and wear-resistance when used in conjunction with soft material parts (SUS, aluminum alloy) employed for toner cartridge mixer shaft and mag roller shaft, etc.

Actual Dimensional Accuracy

For items with an internal diameter of $\phi 8$, the tolerance range is 40 μ m.

Materials: **BEAREE NY5101**, **BEAREE NY5102**, **BEAREE DM50300**

Processing : Injection molding

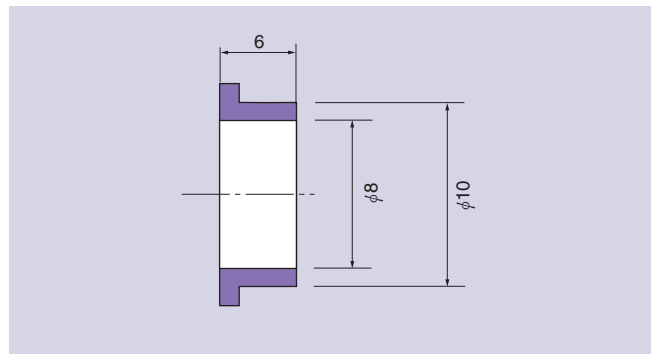

Fig. 1 Example of Typical Dimensions

9. Bearing Units with Seals



Bearing units, made up of a **BEAREE DM5030** bearing and **BEAREE ER3202** seal made of slippery rubber, are used for toner cartridge mixer shaft and mag roller shaft, etc.

Bearing material: **BEAREE DM5030 (POM)**

Seal material: **BEAREE ER3202 (NBR)**

Test time: 50 hr Speed: 7.5 m/min Opposing material: A5056

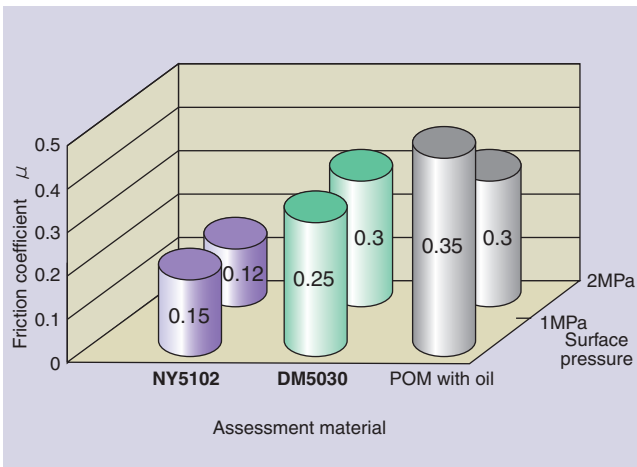

Processing : Seal is press-fitted into injection-molded bearing.
* The seal does not have an outer ring.



Test time: 50 hr Speed: 7.5 m/min Opposing material: A5056

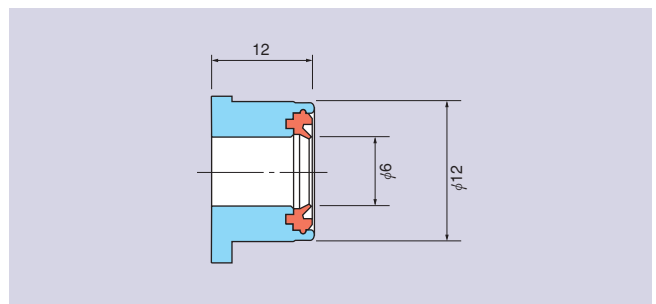
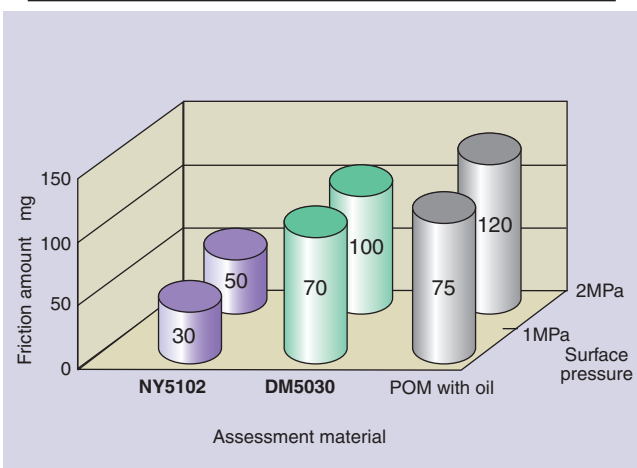

Fig. 1 Example of Typical Dimensions

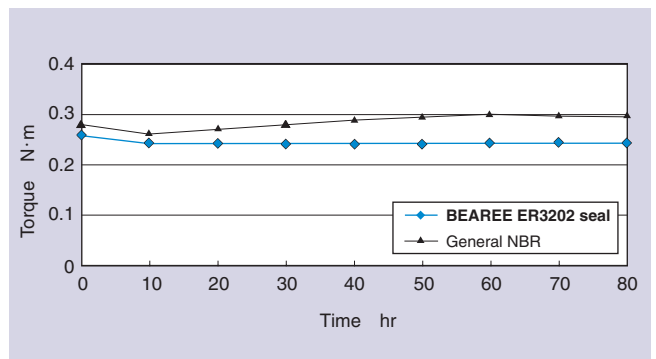

Fig. 2 Temporal Changes in Rotational Torque by Seal Specification (Bearing model is BEAREE DM5030)

10. BEAREE Selection Guidelines



Material for machining Material for injection molding Material for coating

II Resin Products

Plastics	Classification by chemical structure	High performance sliding material	Sliding material for soft mating material	Sliding material for use immersed in water and chemicals	Special application materials	Paper output parts	Gear materials	Separating pin materials	Coating materials	
		Sliding bearings, friction discs, piston rings	Sliding bearings, seal rings	Sliding bearings, hot water pump bearings	Electro-conductive, foodstuff production machinery				Separating pins, roots pump rotors	
Engineering plastics	Super engineering plastics (Specialized engineering plastics)	Polyetheretherketone (PEEK)	Polyethers	PK5900	PK5300					
		Polyethernitrile (PEN)								
		Polyetherimide (PEI)								
		Polyethersulfone (PES)				PK5030				
	High engineering plastics	Fluoroplastics	Fluoroplastics (PTFE)	FL3000	FL3030	FL3700	FL3060	FE5000		FE7030
			(PFA)	FL3020	FL3040		FL3642	FE5101		FE7031
			(FEP)	FL3030	FL3050					FE7092
			(ETFE)	FL3700						
			(PVdF)							
			(FE)							
General purpose engineering plastics	Polyimides	Polyimide (PI)	PI 5001			PI 5001		PI 5030	PI 5022	
			PI 5013	PI 5010		PI 5900		PI 5033		
	Polysulfides	Polyamideimide (PAI)		PI 5013				AI 5003	AI 5003	
		Polyphenylsulfide (PPS)	AS5000	AS5000	AS5704	AS5910		AS5040	AS5021	
	Polyethers	Polysulfone (PSF, PSU)		AS5005		AS5950		AS5044	AS5025	
				AS5054		AS5962		AS5045		
						AS5963				
		Polyacetal (POM)	DM5030	DM5030						
		Modified polyphenylene ether (Modified PPE) (= Modified polyphenylene oxide: Modified PPO)								
		Polyethylene naphthalate (PEN)								
General purpose plastics	Polyamides	Polyethylene terephthalate (PET)								
		Polybutylene terephthalate (PBT)								
	Polyolefins	Polycarbonate (PC)								
		Polyamide (PA)	NY5000			NY5910		NY5010		
	Polyolefins	Epoxy resin (EP)	NY5101			NY5911		NY5910		
		Polyethylene (PE)	NY5102							
	Polyolefins	Polyolefins		UH3000		UH3000				
				UH5041		UH3954				
		Polyvinyls	Polypropylene (PP)				UH5000			
			Polyvinylchloride (PVC)				UH5043			
Polystyrene (PS)										
Acrylonitrile-butadiene-styrene (ABS)										
Elastomer	-	Polymethyl methacrylate (PMMA)								
		Polyurethane (PUR)								
		Phenolic resin (PF)								
		Melamine resin (MF)								
		Urea resin (UF)								
Fluorine oil (PFAE) (PFPE)	-	Silicone resin (SI)								
		Fluororubbers	ER3000	ER3600		ER3002				
		NBRs	ER3201		ER3605					
			ER3202							

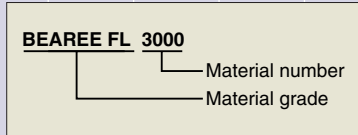

11. Base Resins and Characteristics of Major Grades



[] : Molding method

Grade	Base resin	Characteristics
BEAREE FL	Fluoroplastic (Tetrafluoroethylene)	The base resin of BEAREE FL is a fluoroplastic with excellent characteristics, such as low friction, low adhesion, and resistance to wear, heat, chemicals and weather. Special additives are used in BEAREE FL to ensure the best performance in sliding applications. [Compression molding, extrusion and coating]
BEAREE FE	Fluoroplastic (other than Tetrafluoroethylene) Fluorine oil	The performance of BEAREE FE is slightly lower than that of BEAREE FL, but it is easier to use. It is excellent for low friction and wear resistance, and is suitable for anti-stick coating materials. [Injection molding, extrusion and coating]
BEAREE PI	Polyimide	BEAREE PI has excellent heat resistance and mechanical strength. This material uses special additives to improve the properties of polyimide, which is known as the most heat-resistant plastic. Thermosetting and thermoplastic types are available, and can be selected according to the application. The high water absorption of this type should be taken into consideration in product design. [Injection molding, extrusion, compression molding and coating]
BEAREE AI	Polyamideimide	The heat resistance of BEAREE AI is slightly lower than BEAREE PI, however, it has excellent mechanical properties, such as shock and fatigue resistance. The high water absorption of this type should be taken into consideration in product design. [Injection molding and extrusion]
BEAREE UH	Polyethylene	This material has lower performance than the “super” engineering plastics, but it takes advantage of the excellent properties of polyethylene, such as low friction, high resistance to wear, chemicals and shock, non-sticking quality, and good electrical properties. The shrinkage factor during molding and thermal expansion coefficient are high. It is difficult to bond this material. [Injection molding, extrusion and compression molding]
BEAREE AS	Polyphenylsulfide	BEAREE AS is widely applicable because its base resin of polyphenylenesulfide has excellent heat and wear resistance, mechanical strength and moldability. Also, this material is suited for cost effective mass production. [Injection molding]
BEAREE LC	Aromatic polyester	This material has excellent heat resistance and mechanical strength, especially rigidity. When using with materials based on liquid crystal polymer, designers should consider the anisotropy of the material in product design. [Injection molding]
BEAREE PK	Polyetheretherketone	BEAREE PK is based on polyetheretherketone, which has excellent properties close to polyimide in heat, chemical, shock and fatigue resistance, and self-lubrication. Therefore, the characteristics of this material are similar to BEAREE PI and AI, but with less water absorption. It should be noted during product design that the shrinkage factor during molding is high. [Injection molding and extrusion]
BEAREE NY	Polyamide	This material is based on polyamide, one of the most common general purpose engineering plastics, and it is superior in shock and wear resistance. The heat resistance of this material is lower than “super” engineering plastics, but it is much more economical. It should be noted during product design that the water absorption is high. [Injection molding]
BEAREE DM	Polyoxymethylene (Polyacetal)	This material is based on polyoxymethylene that is superior in fatigue, creep and wear resistance, and dimensional stability. Because of the high levels of oxygen in the molecular structure, however, making this material fire retardant is difficult. As is the case with BEAREE NY, this material is much more economical than “super” engineering plastics based materials. [Injection molding]
BEAREE ER	Elastomer (Sliding Rubber)	BEAREE ER is based on an elastomer. This “sliding rubber” is a fluoroplastic with elasticity and is superior in elasticity, non-stick quality, low friction, and resistance to heat, wear and creep.

■ Products using BEAREE PI, BEAREE AI, BEAREE LC and BEAREE PK are considered strategic products as defined by the Foreign Exchange and Trade Control Act when used for certain purposes and products. When exporting a product that comes under this act, an export license from the Japanese government is required. Contact NTN for details.



III Sintered Products

- 1. Oil-impregnated Sintered Bearings "NTN BEARPHITE".....29
- 2. Hybrid BEARPHITE Bearings33
- 3. Hydrodynamic BEARPHITE Bearings34
- 4. Products under Development35
- 5. NTN BEARPHITE Standard Products36

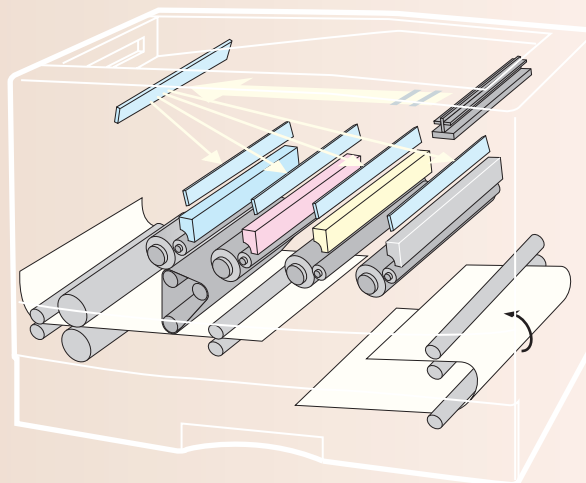

1. Oil-impregnated Sintered Bearings "NTN BEARPHITE"



1.1 Features of "NTN BEARPHITE" oil-impregnated sintered bearings

- **NTN BEARPHITE** is a unique material that has minute, high quality, natural graphite particles added to it. It has excellent bearing properties for a wide range of uses.
- Because **NTN BEARPHITE** is made from sintered metal, it has a porous metal composition, so that it has the necessary lubricant holding and circulating ability which is required of oil-impregnated bearings.
- Because of the stable lubrication properties of **NTN BEARPHITE**, the bearings have a long service life, and they demonstrate excellent bearing performance from low to high temperatures.

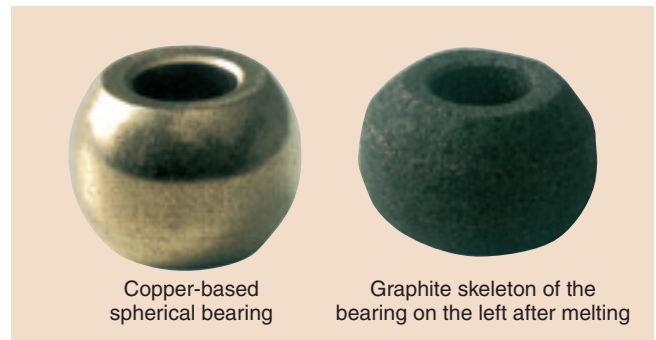

1.2 Available dimensional ranges

Type	Code	Shape	Available ranges			Remarks
			d	D	l	
Sleeve type	S		0.8~60	1.6~70	1~40	$W=0.5 \text{ min.}$ $l=W \times 10$
Flange type	F		0.8~50	2~60	1~35	$W=0.5 \text{ min.}$ $t=0.5 \text{ min.}$ $P \leq t$ $R=0.2 \text{ min.}$
Spherical type	A		1.5~22	5~34	3~20	$C=2 \text{ min.}$ $e=0.8 \text{ min.}$
Thrust washer type	W		5~62	18~75	2~3	$L=1.2 \text{ min.}$
Hydrodynamic BEARPHITE	HDB		1.5	3	3.5~5	
			2	4	6	
			3	5.5	8.75	

* In addition to the above, NTN makes bearings with special shapes and dimensions. Please contact NTN for details.

1.3 Material characteristics of NTN BEARPHITE

Series	Material code	Chemical components %						Density g/cm ³ (±0.2)	Oil retention vol. % (±0.2)	Radial crushing strength MPa(min.) (over)
		Cu	Sn	C	Fe	Ni	Other			
Copper series	H	Residual amount	8~11	1~2	—	—	—	6.6	18	150
	HD	Residual amount	8~11	1~2	—	2~4	—	6.8	18	150
	HQ	Residual amount	8~11	—	—	—	—	6.6	18	150
	HR	Residual amount	8~11	3~4	—	—	—	6.6	12	120
	HZ12	Residual amount	8~11	0.4~1	8~12	2~4	—	6.8	18	150
	HZ16	Residual amount	8~11	0.5~2.5	—	—	P:1 max	7.2	15	150
	HZ18	Residual amount	8~11	—	—	—	MoS ₂ :4~7	6.6	12	150
Copper-iron series	EE	33~38	3~6	1~2	Residual amount	—	3 max	6.2	18	150
	EB	18~22	0.5~2.5	0.5~2.5	Residual amount	—	1 max	6.2	18	150
	EC	38~42	1~3	0.5~2.5	Residual amount	—	1 max	6.4	18	150
	EZ06	Residual amount	1~3	0.5~2.5	38~42	—	1 max	6.9 6.5	12 18	150
	EZ10	35~45	1~3	0.5~1.5	Residual amount	—	1 max	6.4	18	150
Iron series	P	8~11	—	—	Residual amount	—	3 max	6.1	18	200
	F	—	—	—	Residual amount	—	3 max	5.9	20	180
	L	1~3	—	2~4	Residual amount	—	1 max	6.0	15	180

1.4 Materials used in office equipment and bearing properties

Series	Material code	Bearing properties						Remarks
		Audio	Vibration	Sliding	High temperature	High speed	Load	
Copper series	H	◎	○	○	○	○	○	Standard copper series material
	HQ	○	○	◎	△	△	△	Suitable for sliding applications
	HR	△	○	△	◎	△	○	Excellent wear resistance at high temperatures
Copper-iron series	EB	○	○	△	△	△	○	Alternative for copper-iron series EC material
	EC	○	○	△	△	△	○	Alternative for copper series H material
	EZ06	○	○	△	△	○	◎	Excellent wear resistance
	EZ10	○	○	○	○	○	◎	Excellent wear resistance
Iron series	P	△	△	○	△	◎	○	Suitable as a high strength material
	F	△	△	△	△	○	○	Standard iron series material

Note) ◎ Excellent ○ Good △ Poor

1.5 Technical data

1.5.1 Relations between material temperature increases (heat generation) and friction coefficient

- H material (copper series) has the lowest temperature increase and friction coefficient.
- The order of materials according to temperature increases and friction coefficients are as follows:
H material (copper series) < HQ material (copper series) < EC material (copper-iron series) < F material (iron series)

1) Sample

Bearing size : S6×12×8
 Lubricant : ISO VG68
 Bearing material : H, HQ, EC, F
 Shaft materia : SUJ2 Shaft hardness : HRC60
 Shaft surface roughness : Ra0.2μm

2) Test conditions

Surface pressure : 0.2~2.0MPa
 Rim speed : 38m/min
 Operating clearance : 12μm
 Room temperature : 25±2°C

3) Test equipment

Type A testing machine used (Figure 1 shows an outline.)

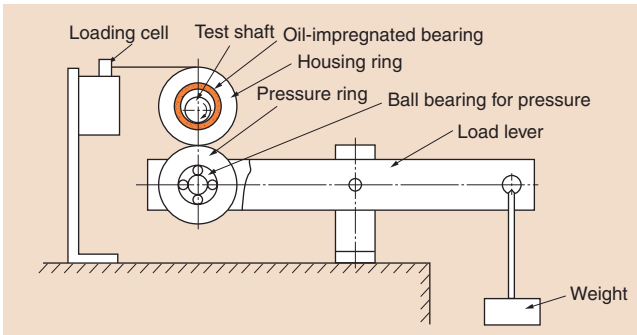

Fig. 1 Outline of the Type A Testing Machine

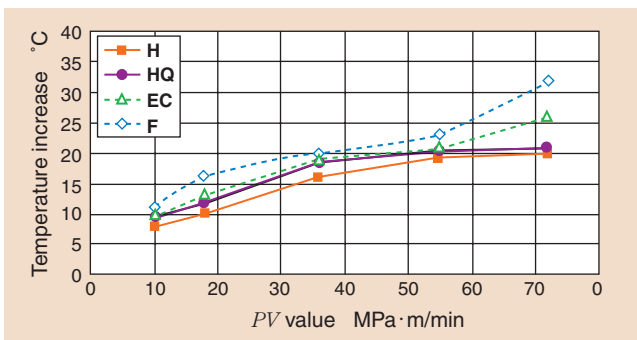

Fig. 2 Temperature Increase Caused by Bearing Material

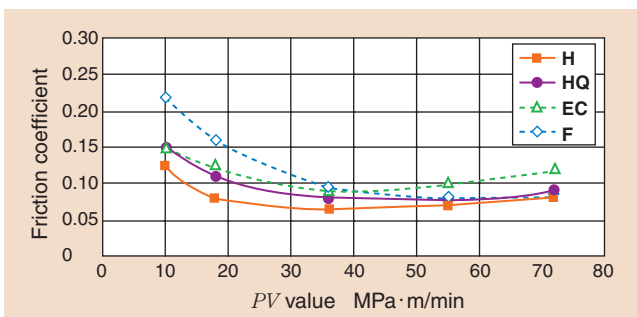

Fig. 3 Friction Coefficient Based on Bearing Material

1.5.2 Relation between operating clearance and lubricant viscosity with temperature increases and friction coefficients

- When the operating clearance is 10 μm or less, there is a tendency for heat generation and higher friction coefficients.
- The higher the viscosity of the lubricant, the higher the temperature and friction coefficient.

1) Sample

Bearing size : S6×12×8
 Lubricant : ISO VG32, VG68, VG100
 Bearing material : H material (copper series)
 Shaft materia : SUJ2 Shaft hardness : HRC60
 Shaft surface roughness : Ra0.2μm

2) Test conditions

Surface pressure : 0.2~2.0MPa
 Rim speed : 38m/min
 Operating clearance : 12μm
 Room temperature : 25±2°C

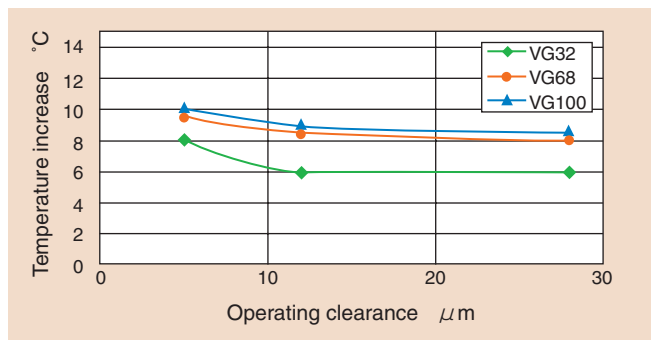

Fig. 4 Temperature Increase Caused by Operating Clearance and Lubricant Viscosity

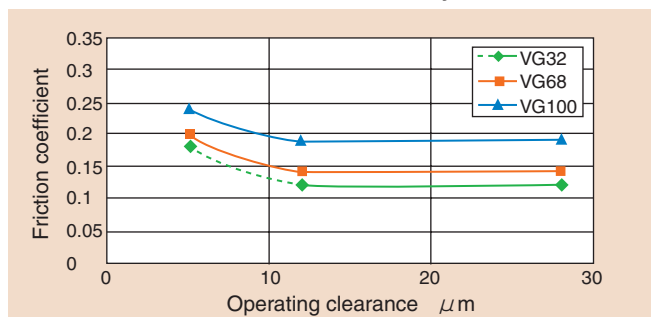

Fig. 5 Friction Coefficient Based on Operating Clearance and Lubricant Viscosity

1.5.3 Friction properties when sliding

1) Sample

Bearing size : S6×10×5
 Bearing material : H, HQ, HR
 Lubricant : ISO VG 68
 Shaft materia : SUS 420J2
 Shaft surface roughness : 0.2μmRa
 Shaft hardness : HV580

2) Test conditions

Surface pressure : 0.07MPa
 Sliding speed : 5.8m/min
 Stroke : 160mm
 Operating clearance : 10~14μm
 Room temperature : 25±2°C

1) Sample

Bearing size : S6×10×5
 Bearing material : H
 Shaft materia : SUS 420J2
 Shaft surface roughness : 0.2μmRa
 Shaft hardness : HV580

2) Test conditions

Surface pressure : 0.08MPa
 Sliding speed : 5.4m/min
 Stroke : 160mm
 Operating clearance : 10~14μm
 Room temperature : 25±2°C

3) Test results

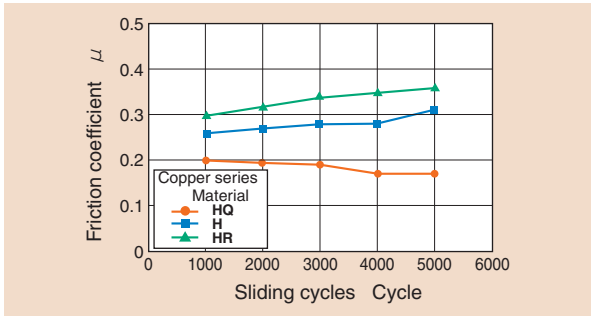

3) Test results

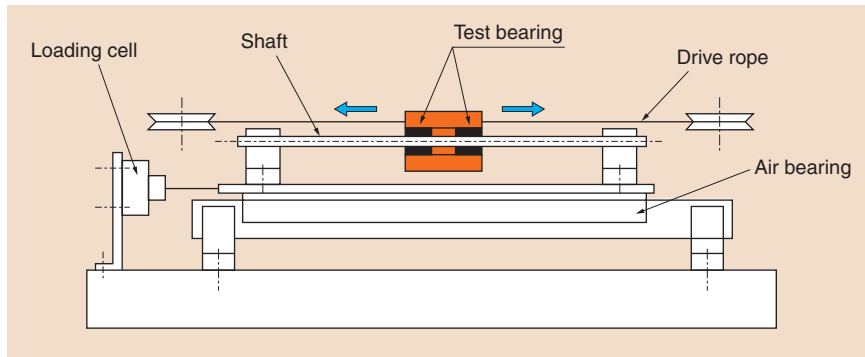
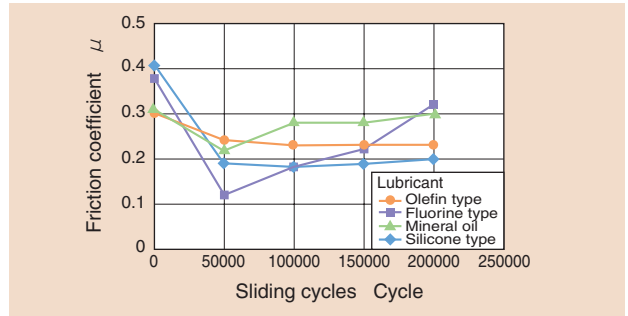

Fig. 6 Test Machine

1.6 Oil-resistance test results of the resin (80°C×72h)

No.	Resin name	Mineral oil	Synthetic hydrocarbon	Ester based	Alkylphenyl ether	Liquid grease	
		Tellus 68	Floil 947P	Alltime J652	Moresco BS-100	AL-1	EU-1
1	Polyphenylene ether	○	△	△	△	△	○
2	Polyphenylsulfide	○	○	○	○	○	○
3	Polycarbonate	○	○	× ¹⁾	○	× ²⁾	○
4	Polyetherimied	◎	◎	◎	◎	◎	◎
5	Polybutylene terephthalate	○	○	○	○	○	○
6	Polyamide	○	○	○	○	○	◎
7	Polyoxymethylene (POM) (= Polyacetal)	○	○	○	○	○	○
8	Acrylonitrile-butadiene-styrene resin	△	△	△	△	△	△
9	Polyethylene terephthalate	○	○	○	○	○	○
10	Polyarylate	○	◎	× ¹⁾	◎	○	◎

Note) ◎ : Deformation ratio up to 40% ○ : Deformation ratio 41 to 70% △ : Deformation ratio 71% or greater × : Breaks

1) After 24 hours, break occurs

2) After 72 hours, cracks in several areas

【Test machine】

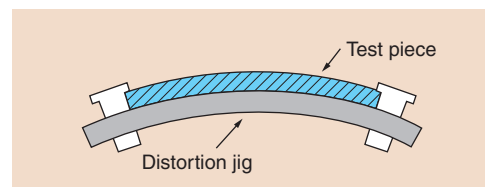

2. Hybrid BEARPHITE Bearings



2.1 Hybrid BEARPHITE bearings

Currently, roller bearings are being used for light load conditions, such as in office equipment, but in order to reduce costs many companies are considering replacing these roller bearings with sliding bearings. However, because office equipment uses many shafts made of aluminum and SUM electroplated with nickel, these shafts can be damaged by oil-impregnated bearings. Resin bearings cannot be used in locations where accuracy is required, and their use is also limited because of their high linear expansion coefficient.

Therefore, we combined the dimensional precision of metal with the sliding ability of resin to realize “Hybrid BEARPHITE” as an alternative to roller bearings. This hybrid bearing achieves **low friction, high precision** and **quiet operation**.

2.2 Features

- More accurate than resin bearings.
- Can be used even when the shaft is aluminum.
- Low friction ($\mu = 0.05$)
- Quieter than roller bearings.
- Can withstand axial loads.

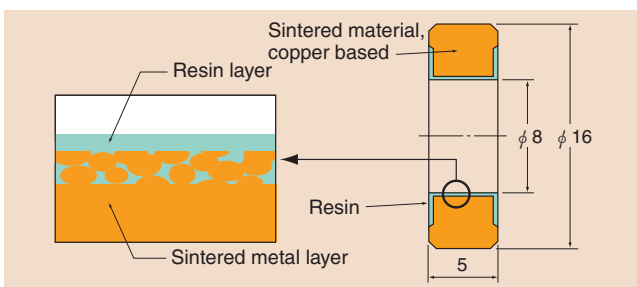

2.3 Comparison with other bearings

Item	Hybrid BEARPHITE	Resin slide bearing	Oil-impregnated sintered bearing
Bore	$\pm 5 \mu\text{m}$	$\pm 15 \mu\text{m}$	$\pm 5 \mu\text{m}$
Outer diameter	$\pm 8 \mu\text{m}$	$\pm 15 \mu\text{m}$	$\pm 8 \mu\text{m}$
Bore roundness	10 μm or less	50 μm or less	10 μm or less
Concentricity	15 μm or less	30 μm or less	15 μm or less
Cylindricality	10 μm or less	40 μm or less	10 μm or less
Dimension changes	○	×	○
Sliding against aluminum	○	○	×
Sliding against SUM+Ni electroplating	○	○	△

2.4 Hybrid BEARPHITE dimensions

Bore	Outer diameter	Length	Roller bearing code
$\phi 6$	$\phi 12$	4	WBC6-12ZZ
$\phi 8$	$\phi 16$	5	W688AZZ
	$\phi 22$	7	608ZZ

2.5 Technical data

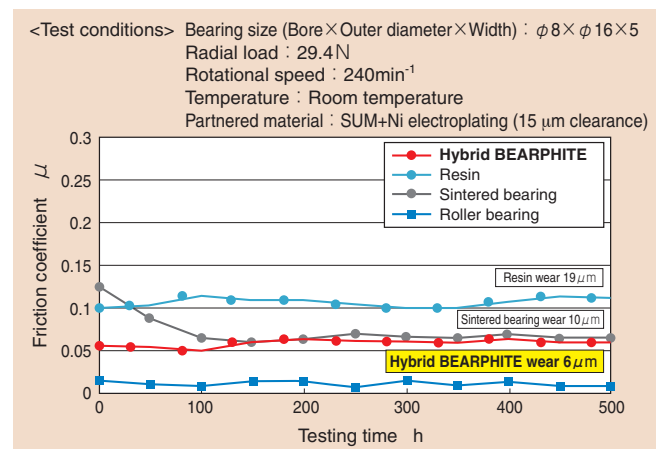

Fig. 1 Hybrid BEARPHITE Wear Properties

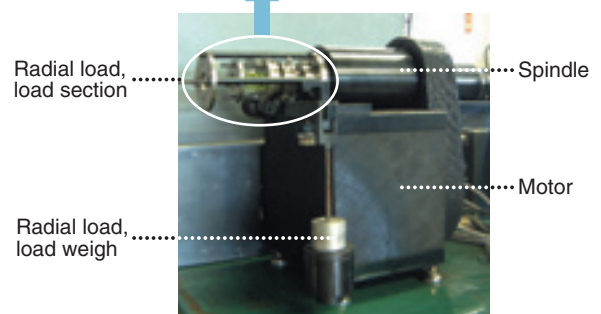
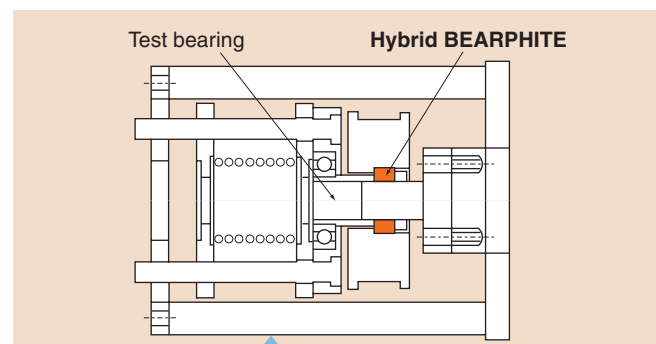

Fig. 2 Wear Testing Device

3. Hydrodynamic BEARPHITE Bearings

3.1 Lubrication principle of hydrodynamic BEARPHITE bearings

Hydrodynamic BEARPHITE bearings are oil-impregnated sintered bearings with herringbone hydrodynamic grooves on the bore surface.

The hydrodynamic effect of these bearings creates a good oil film, so that the shaft is totally supported in a non-contact state during operation. This contributes to high rotational accuracy, low noise and long service life. Because of these features, these bearings are widely used in polygon scanner motors, cooling fans, etc. When the spindle rotates, the action caused by the opposing inclined grooves forms a good oil film inside the entire bearing clearance, so that the spindle is supported very rigidly.

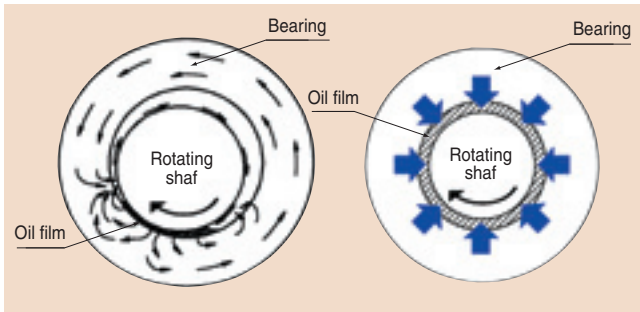

Fig. 1 Oil-impregnated Bearing Oil Film and Movement of Oil

Fig. 2 Hydrodynamic Bearing Oil Film and Movement of Oil

3.2 Comparison with other bearings

	Hydrodynamic BEARPHITE	Fluid hydrodynamic bearing	Roller bearing	Oil-impregnated sintered bearing
Rotational accuracy	◎	◎	○	×
High speed range	◎	◎	○	×
Low speed range	○	×	◎	○
Seizure resistance	◎	×	○	○
Noise	◎	◎	×	○
Torque	△	△	◎	○
Cost	○	△	△	◎

◎ : Excellent ○ : Good △ : Usable × : Not usable

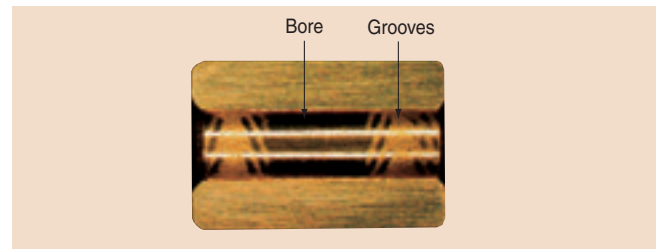

3.3 Hydrodynamic BEARPHITE usage example

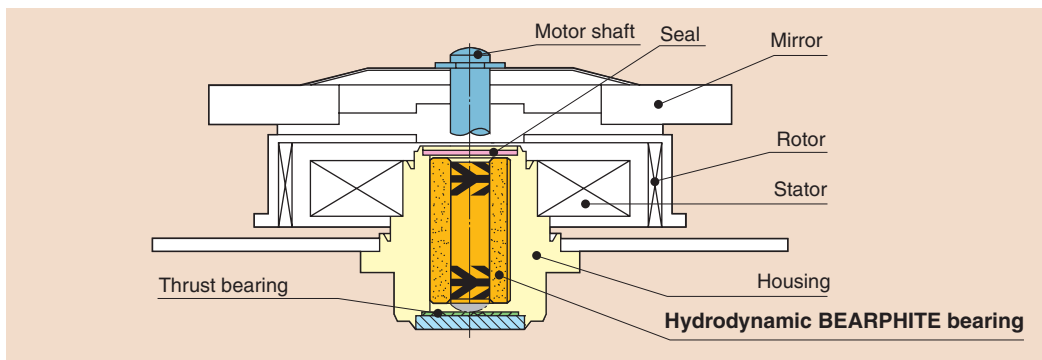
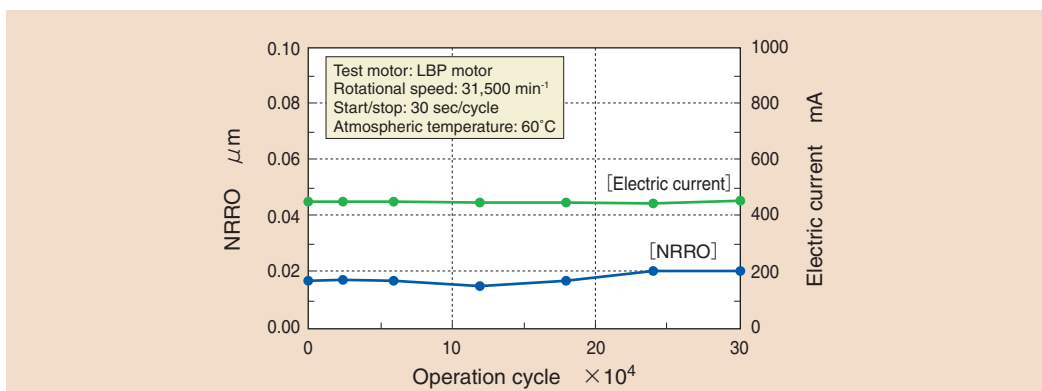

Fig. 3 Structural Diagram of Hydrodynamic BEARPHITE Bearing Used in LBP

3.4 Technical data



4. Products under Development

4.1 NTN BEARPHITE SG

4.1.1 NTN BEARPHITE SG

NTN BEARPHITE SG is a series of oil-impregnated sintered bearings that use a special liquid grease. This grease stabilizes the rotational torque of the bearing over a wide range of operating temperatures, and the small amount of leakage vastly improves the durability of the bearing.

There are two types of grease: AL-1 for normal temperatures and EU-1 for high temperatures.

4.1.2 AL-1 properties

Typical characteristics of AL-1

Item	Properties
Allowed temperature range	80°C or less
Base oil	Synthetic oil (PE based)
Thickener	Lithium
Uses	Office equipment, cooling fans

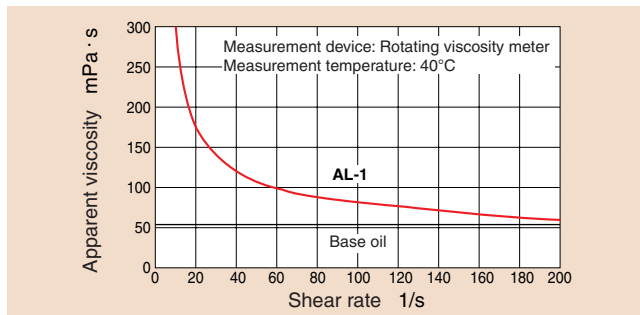

Fig. 1 Shear Rate Dependency of Apparent Viscosity (AL-1)

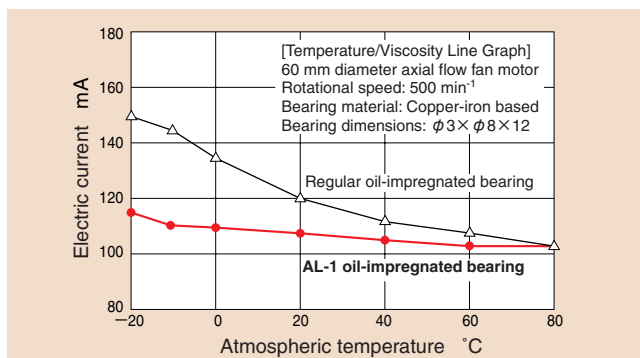

Fig. 2 Temperature Dependency of Axial Flow Fan Drive Current

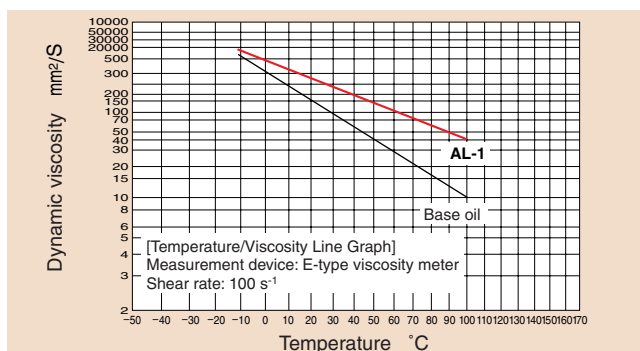

Fig. 3 Temperature Dependency of Viscosity (AL-1)

Typical characteristics of EU-1

Item	Properties
Allowed temperature range	140°C or less
Base oil	Synthetic oil
Thickener	Urea
Uses	Office equipment, automobile electronic components

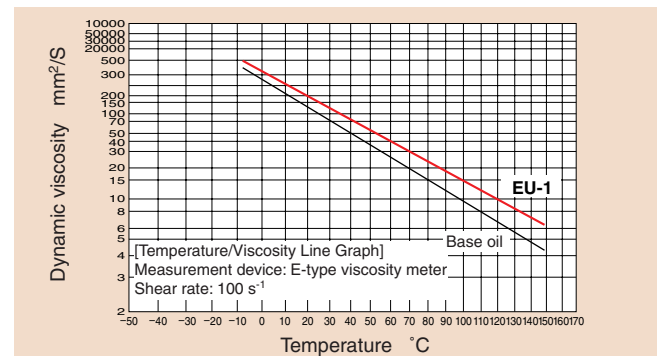

Fig. 4 Temperature Dependency of Viscosity (EU-1)

4.2 Oil-impregnated bearings with improved wear resistance

4.2.1 Features

These bearings have superior wear resistance when compared with conventional oil-impregnated bearings, so that aggressivity on the shafts is reduced.

4.2.2 Material (EZ10)

A copper layer is formed on the surface of the bearings.

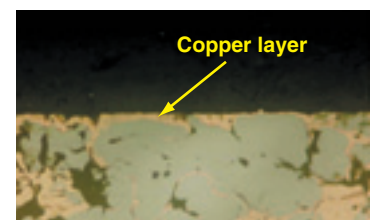

Bearing Cross Section Photograph

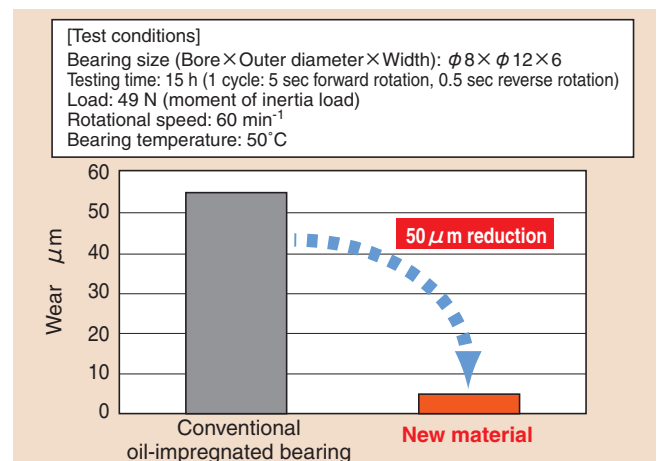
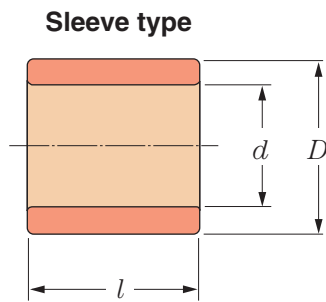

Fig. 1 Test Results

5. NTN BEARPHITE Standard Products



The bearing dimensions and tolerances of the sleeve and flange models are summarized in the table below. NTN owns the dies, so that there is no die cost.



Dimension example :
S $d \times D \times l$

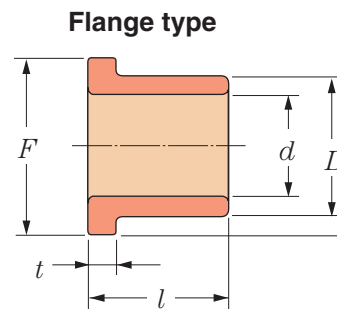

Dimension example :
F $d \times D \times l : F \times t$

Dimension units: mm

Sleeve Bearings

d 4mm

Bore	Dimensions mm			Product code		
	ϕd	Outer diameter ϕD	Length l			
4	+0.030 +0.010	6	+0.055 +0.035	3	0 -0.100	B-S4-1047
4	+0.012 0	6	+0.038 +0.023	3.8	+0.050 0	B-S4-194
4	+0.012 0	6	+0.038 +0.023	4.5	± 0.100	B-S4-1004
4	+0.030 0	6	0 -0.030	4.5	± 0.100	B-S4-1040
4	+0.012 0	6	+0.038 +0.023	5	± 0.100	B-S4-1220
4	+0.012 0	6	+0.038 +0.023	6	0 -0.100	B-S4-73
4	+0.020 +0.012	6	+0.015 +0.005	6	0 -0.100	B-S4-1142
4	+0.028 +0.010	6	+0.034 +0.019	7	0 -0.100	B-S4-110
4	+0.030 0	7	+0.038 +0.023	2	0 -0.100	B-S4-1042
4	+0.004 -0.002	7	+0.020 +0.010	4	± 0.100	B-S4-87
4	+0.012 0	7	+0.038 +0.023	6	± 0.100	B-S4-11
4	+0.012 0	7	+0.038 +0.023	8	± 0.150	B-S4-1218
4	+0.012 0	7	+0.038 +0.023	8	0 -0.150	B-S4-105
4	+0.012 0	7	+0.038 +0.023	10	0 -0.150	B-S4-1242
4	+0.012 0	8	+0.038 +0.023	3	± 0.100	B-S4-21
4	+0.015 +0.007	8	+0.008 0	3	± 0.100	B-S4-1023
4	+0.022 +0.010	8	+0.038 +0.023	4	± 0.100	B-S4-84
4	+0.030 +0.010	8	+0.030 +0.020	4	0 -0.100	B-S4-1153
4	+0.020 +0.010	8	+0.038 +0.023	5	0 -0.100	B-S4-74
4	+0.012 0	8	+0.038 +0.023	6	± 0.100	B-S4-30

d 4~5mm

Bore	Dimensions mm			Product code		
	ϕd	Outer diameter ϕD	Length l			
4	+0.012 0	8	+0.038 +0.023	8	± 0.100	B-S4-31
4	+0.012 0	9	+0.038 +0.023	5	0 -0.200	B-S4-36
4	+0.012 0	9	+0.038 +0.023	6	± 0.100	B-S4-37
4	+0.026 +0.014	10	+0.038 +0.023	7	± 0.100	B-S4-68
4	+0.012 0	10	+0.038 +0.023	8	± 0.150	B-S4-40
4	+0.012 0	10	+0.038 +0.023	20	± 0.150	B-S4-55
5	+0.020 0	7	+0.040 +0.020	2.4	0 -0.100	B-S5-1039
5	+0.020 +0.013	7	+0.040 +0.025	3	± 0.100	B-S5-146
5	+0.035 +0.020	7	+0.040 +0.025	4	0 -0.300	B-S5-1084
5	+0.040 +0.025	7	+0.040 +0.020	4	± 0.050	B-S5-1099
5	+0.035 +0.020	7	+0.040 +0.025	5	0 -0.300	B-S5-1213
5	+0.025 +0.005	7	+0.050 +0.020	6	± 0.100	B-S5-1152
5	+0.030 +0.010	8	+0.040 +0.020	3.5	0 -0.100	B-S5-1024
5	+0.023 +0.013	8	+0.023 +0.013	4	± 0.100	B-S5-41
5	+0.020 +0.012	8	+0.015 +0.005	4	0 -0.100	B-S5-1141
5	+0.070 +0.050	8	+0.030 +0.010	5	± 0.100	B-S5-1241
5	+0.035 +0.025	8	+0.038 +0.023	5	± 0.050	B-S5-89
5	+0.040 +0.020	8	+0.020 0	6	± 0.100	B-S5-5
5	+0.012 0	8	+0.028 +0.012	8	± 0.150	B-S5-10
5	+0.012 0	8	+0.038 +0.023	10	± 0.150	B-S5-39

Note: Please contact NTN with regard to the type of oil.
The material is copper based (H).

Sleeve Bearings

d 5~6mm

	Dimensions mm				Product code	
	Bore ϕd	Outer diameter ϕD	Length ℓ			
5	+0.012 0	8	+0.038 +0.023	12	± 0.150	B-S5-14
5	+0.015 0	9	+0.030 +0.015	4	± 0.100	B-S5-1123
5	+0.030 +0.010	9	+0.040 +0.020	4	$\begin{matrix} 0 \\ -0.100 \end{matrix}$	B-S5-134
5	+0.020 +0.005	9	+0.030 +0.015	5	± 0.100	B-S5-87
5	+0.025 +0.013	9	+0.039 +0.018	6	± 0.100	B-S5-19
5	+0.012 0	9	+0.038 +0.023	10	± 0.150	B-S5-1032
5	+0.015 0	10	+0.030 +0.015	3	± 0.100	B-S5-1125
5	+0.012 0	10	+0.038 +0.023	4	± 0.100	B-S5-22
5	+0.019 +0.013	10	+0.038 +0.023	4.5	$\begin{matrix} 0 \\ -0.100 \end{matrix}$	B-S5-1034
5	+0.020 +0.012	10	+0.015 +0.005	4.5	$\begin{matrix} 0 \\ -0.100 \end{matrix}$	B-S5-1142
5	+0.028 +0.018	10	+0.020 +0.010	6	± 0.100	B-S5-25
5	+0.018 +0.006	10	+0.038 +0.023	7	± 0.100	B-S5-40
5	+0.012 +0.006	11	+0.040 +0.032	4	± 0.100	B-S5-97
5	+0.012 +0.006	11	+0.040 +0.032	5	± 0.100	B-S5-109
5	+0.012 0	12	+0.046 +0.028	11	± 0.100	B-S5-31
5	+0.050 +0.020	13	+0.030 +0.010	5	$\begin{matrix} 0 \\ -0.100 \end{matrix}$	B-S5-66
6	+0.030 +0.010	8	+0.040 +0.020	3	$\begin{matrix} 0 \\ -0.100 \end{matrix}$	B-S6-1292
6	+0.040 +0.025	8	+0.040 +0.020	3	$\begin{matrix} 0 \\ -0.100 \end{matrix}$	B-S6-1051
6	+0.020 +0.012	8	+0.015 +0.005	3	$\begin{matrix} 0 \\ -0.100 \end{matrix}$	B-S6-311
6	+0.027 +0.017	8	+0.035 +0.020	4	± 0.100	B-S6-168
6	+0.040 +0.025	8	+0.040 +0.020	4	± 0.050	B-S6-1035
6	+0.030 +0.010	8	+0.040 +0.020	4	$\begin{matrix} 0 \\ -0.100 \end{matrix}$	B-S6-1048
6	+0.020 0	8	+0.050 +0.020	4	± 0.100	B-S6-1060
6	+0.020 0	8	+0.050 +0.020	5	$\begin{matrix} 0 \\ -0.100 \end{matrix}$	B-S6-2
6	+0.020 +0.005	8	+0.040 +0.020	5	± 0.050	B-S6-1050
6	+0.020 0	8	+0.038 +0.023	5	± 0.100	B-S6-1093
6	+0.040 +0.025	8	+0.040 +0.020	5	± 0.050	B-S6-1139
6	+0.027 +0.017	8	+0.035 +0.020	6	± 0.100	B-S6-4
6	+0.038 +0.020	8	-0.013 -0.035	6	± 0.100	B-S6-1129
6	+0.020 0	8	+0.050 +0.020	8	$\begin{matrix} -0.050 \\ -0.250 \end{matrix}$	B-S6-7
6	+0.020 +0.010	8	+0.050 +0.020	8	$\begin{matrix} -0.050 \\ -0.250 \end{matrix}$	B-S6-199
6	+0.030 +0.015	8	+0.038 +0.023	8	$\begin{matrix} 0 \\ -0.100 \end{matrix}$	B-S6-1189
6	+0.020 0	8	+0.050 +0.020	8	$\begin{matrix} -0.050 \\ -0.250 \end{matrix}$	B-S6-1246

d 6mm

	Dimensions mm				Product code	
	Bore ϕd	Outer diameter ϕD	Length ℓ			
6	+0.012 0	8	+0.038 +0.023	9	$\begin{matrix} 0 \\ -0.100 \end{matrix}$	B-S6-8
6	+0.020 +0.010	8	+0.050 +0.040	9.6	$\begin{matrix} 0 \\ -0.200 \end{matrix}$	B-S6-301
6	+0.030 +0.015	8	+0.038 +0.023	10	± 0.100	B-S6-140
6	+0.040 +0.020	8	+0.046 +0.028	10	$\begin{matrix} -0.050 \\ -0.200 \end{matrix}$	B-S6-177
6	+0.015 0	8	+0.038 +0.023	10	$\begin{matrix} 0 \\ -0.300 \end{matrix}$	B-S6-262
6	+0.012 0	8	+0.110 +0.075	12	± 0.150	B-S6-1080
6	+0.023 +0.008	8	+0.038 +0.023	13	$\begin{matrix} 0 \\ -0.150 \end{matrix}$	B-S6-146
6	+0.018 0	9	+0.038 +0.023	3	± 0.100	B-S6-194
6	+0.035 +0.025	9	+0.038 +0.023	3	$\begin{matrix} 0 \\ -0.200 \end{matrix}$	B-S6-342
6	+0.023 +0.008	9	+0.038 +0.023	4	± 0.100	B-S6-1191
6	+0.035 +0.025	9	+0.038 +0.023	5	± 0.050	B-S6-180
6	+0.015 0	9	+0.038 +0.023	6	± 0.100	B-S6-17
6	+0.015 0	9	+0.038 +0.023	6	± 0.100	B-S6-1343
6	+0.015 0	9	+0.038 +0.023	8	± 0.100	B-S6-18
6	+0.035 +0.025	9	+0.038 +0.023	8	± 0.100	B-S6-211
6	+0.015 0	9	+0.038 +0.023	10	± 0.100	B-S6-19
6	+0.035 +0.025	9	+0.038 +0.023	10	± 0.100	B-S6-165
6	+0.015 0	9	+0.030 +0.015	16	± 0.100	B-S6-230
6	+0.030 +0.015	10	+0.038 +0.023	2	$\begin{matrix} 0 \\ -0.100 \end{matrix}$	B-S6-328
6	+0.035 +0.023	10	+0.038 +0.023	3	± 0.100	B-S6-219
6	+0.030 +0.015	10	+0.041 +0.025	3	$\begin{matrix} 0 \\ -0.100 \end{matrix}$	B-S6-321
6	+0.030 +0.015	10	+0.041 +0.025	3.5	$\begin{matrix} 0 \\ -0.100 \end{matrix}$	B-S6-149
6	+0.020 +0.012	10	+0.015 +0.005	3.5	$\begin{matrix} 0 \\ -0.100 \end{matrix}$	B-S6-1193
6	+0.015 0	10	+0.038 +0.023	4	± 0.100	B-S6-110
6	+0.020 +0.012	10	+0.015 +0.005	4	$\begin{matrix} 0 \\ -0.100 \end{matrix}$	B-S6-1194
6	+0.030 +0.015	10	+0.038 +0.023	4	$\begin{matrix} 0 \\ -0.100 \end{matrix}$	B-S6-265
6	+0.045 +0.035	10	+0.038 +0.023	4	$\begin{matrix} 0 \\ -0.100 \end{matrix}$	B-S6-1256
6	+0.035 +0.023	10	+0.038 +0.023	5	$\begin{matrix} +0.200 \\ 0 \end{matrix}$	B-S6-272
6	+0.020 +0.012	10	+0.015 +0.005	5	$\begin{matrix} 0 \\ -0.100 \end{matrix}$	B-S6-1196
6	+0.070 +0.050	10	+0.038 +0.023	5	± 0.100	B-S6-316
6	+0.030 +0.015	10	+0.041 +0.025	5	± 0.100	B-S6-197
6	+0.015 0	10	+0.038 +0.023	6	± 0.100	B-S6-218
6	+0.030 +0.015	10	+0.041 +0.025	6	$\begin{matrix} 0 \\ -0.100 \end{matrix}$	B-S6-288

Note: Please contact NTN with regard to the type of oil.
The material is copper based (H).

Sleeve Bearings

d 6~7mm

Bore	Dimensions mm			Product code		
	ϕd	Outer diameter ϕD	Length ℓ			
6	+0.020 +0.012	10	+0.015 +0.005	6	0 -0.100	B-S6-1197
6	+0.012 0	10	+0.038 +0.023	7	± 0.100	B-S6-117
6	+0.012 0	10	+0.038 +0.023	8	± 0.100	B-S6-85
6	+0.045 +0.033	10	+0.038 +0.023	8	0 -0.100	B-S6-1312
6	+0.012 0	10	+0.038 +0.023	9	± 0.100	B-S6-39
6	+0.012 0	10	+0.038 +0.023	10	0 -0.100	B-S6-43
6	+0.015 0	10	+0.038 +0.023	11	± 0.100	B-S6-45
6	+0.015 0	10	+0.038 +0.023	12	± 0.150	B-S6-46
6	+0.012 0	10	+0.046 +0.028	13	± 0.100	B-S6-48
6	+0.020 +0.012	10	+0.033 +0.023	14	-0.300 -0.500	B-S6-160
6	+0.012 0	10	+0.038 +0.023	15	± 0.150	B-S6-52
6	+0.050 +0.020	10	0 -0.030	17	± 0.150	B-S6-88
6	+0.017 +0.005	10	+0.038 +0.023	17	± 0.100	B-S6-310
6	+0.040 +0.020	11	+0.041 +0.023	4	± 0.100	B-S6-175
6	+0.033 +0.018	11	+0.038 +0.023	5	+0.200 0	B-S6-1325
6	+0.012 0	12	+0.046 +0.028	3	± 0.100	B-S6-1359
6	+0.010 0	12	+0.046 +0.028	3	-0.100 -0.300	B-S6-1061
6	+0.012 0	12	+0.046 +0.028	4	± 0.100	B-S6-1395
6	+0.012 0	12	+0.038 +0.023	6	± 0.100	B-S6-353
6	+0.012 0	12	+0.046 +0.028	7	± 0.100	B-S6-196
6	+0.040 +0.020	12	+0.200 0	8	± 0.100	B-S6-62
6	+0.012 0	12	+0.046 +0.028	8	± 0.100	B-S6-63
6	+0.030 +0.010	12	+0.040 +0.020	8	0 -0.100	B-S6-279
6	+0.040 +0.020	12	+0.200 0	9	± 0.150	B-S6-65
6	+0.012 0	12	+0.046 +0.028	12	± 0.100	B-S6-179
6	+0.035 +0.020	12	+0.048 +0.028	17	0 -0.100	B-S6-299
6	+0.012 0	12	+0.046 +0.028	19	± 0.150	B-S6-1321
6	+0.012 0	12	+0.046 +0.028	20	± 0.150	B-S6-245
6	+0.012 +0.006	13	+0.046 +0.028	3.5	± 0.100	B-S6-227
6	+0.015 0	13	+0.030 +0.010	5	± 0.100	B-S6-215
6	+0.015 0	13	-0.020 -0.040	5	± 0.100	B-S6-1340
6	+0.018 +0.006	15	+0.046 +0.028	5	± 0.100	B-S6-184
7	+0.012 0	9	+0.038 +0.023	6	± 0.100	B-S7-63

d 7~8mm

Bore	Dimensions mm			Product code		
	ϕd	Outer diameter ϕD	Length ℓ			
7	+0.025 +0.010	10	+0.038 +0.023	4	± 0.100	B-S7-1255
7	+0.015 0	10	+0.035 +0.023	10	± 0.150	B-S7-4
7	+0.025 +0.010	10	+0.038 +0.023	10	± 0.050	B-S7-1110
7	+0.012 0	10	± 0.030	12	0 -0.100	B-S7-23
7	+0.020 0	11	0 -0.027	3	0 -0.100	B-S7-55
7	+0.040 +0.020	11	+0.051 +0.033	7	± 0.100	B-S7-6
7	+0.015 0	11	+0.046 +0.028	10	± 0.150	B-S7-24
7	+0.015 0	12	+0.046 +0.028	5	± 0.100	B-S7-1025
7	+0.053 +0.038	12	+0.046 +0.028	7	± 0.100	B-S7-46
7	+0.015 0	13	0 -0.020	4	± 0.050	B-S7-14
7	+0.015 0	13	+0.046 +0.028	15	± 0.150	B-S7-22
7	+0.048 +0.033	14	+0.046 +0.028	10	± 0.100	B-S7-48
8	+0.030 +0.015	10	+0.038 +0.023	3	± 0.100	B-S8-413
8	+0.020 +0.012	10	+0.015 +0.005	3	0 -0.100	B-S8-423
8	+0.020 +0.012	10	+0.015 +0.005	3.5	0 -0.100	B-S8-411
8	+0.030 +0.015	10	+0.038 +0.023	5	± 0.100	B-S8-1406
8	+0.030 +0.010	10	0 -0.020	5	0 -0.500	B-S8-394
8	+0.045 +0.030	10	+0.038 +0.023	6	± 0.100	B-S8-235
8	+0.030 +0.015	10	+0.038 +0.023	8	± 0.100	B-S8-1504
8	+0.015 0	10	+0.038 +0.023	8	± 0.100	B-S8-187
8	+0.015 0	10	+0.038 +0.023	10	± 0.100	B-S8-5
8	+0.035 +0.020	10	+0.040 +0.020	15	± 0.150	B-S8-1497
8	+0.018 0	11	+0.038 +0.023	4	± 0.100	B-S8-342
8	+0.029 +0.014	11	+0.043 +0.028	10	± 0.100	B-S8-160
8	+0.015 0	11	+0.046 +0.028	12	± 0.150	B-S8-17
8	+0.022 0	11	+0.055 +0.028	18	± 0.150	B-S8-20
8	+0.015 0	11	+0.046 +0.028	20	± 0.150	B-S8-21
8	+0.040 +0.015	11	+0.046 +0.016	25	0 -0.300	B-S8-243
8	+0.020 0	12	+0.030 +0.010	2	0 -0.100	B-S8-1388
8	+0.015 0	12	+0.038 +0.023	3	± 0.100	B-S8-354
8	+0.050 +0.010	12	+0.050 0	3	± 0.100	B-S8-1232
8	+0.040 +0.025	12	+0.046 +0.028	4	0 -0.100	B-S8-192
8	+0.015 0	12	+0.046 +0.028	4	0 -0.100	B-S8-414

Note: Please contact NTN with regard to the type of oil.
The material is copper based (H).

Sleeve Bearings

d 8mm

Bore ϕd	Dimensions mm			Product code		
	Outer diameter ϕD	Length ℓ				
8	+0.030 +0.010	12	+0.040 +0.020	4	0 -0.100	B-S8-358
8	+0.015 0	12	+0.038 +0.023	5	± 0.100	B-S8-356
8	+0.020 +0.005	12	+0.038 +0.023	5	± 0.050	B-S8-1141
8	+0.030 +0.015	12	+0.041 +0.023	5	0 -0.100	B-S8-1252
8	+0.018 0	12	+0.046 +0.028	6	± 0.100	B-S8-32
8	+0.015 0	12	+0.046 +0.028	6	± 0.100	B-S8-36
8	+0.035 +0.015	12	+0.041 +0.023	6	± 0.100	B-S8-288
8	+0.034 +0.025	12	+0.046 +0.028	6	± 0.100	B-S8-370
8	+0.055 +0.040	12	+0.046 +0.028	6	± 0.100	B-S8-1100
8	+0.015 0	12	+0.046 +0.028	8	± 0.100	B-S8-42
8	+0.040 +0.025	12	+0.046 +0.028	8	0 -0.100	B-S8-169
8	+0.030 +0.015	12	+0.041 +0.023	8	0 -0.100	B-S8-1253
8	+0.020 +0.005	12	+0.046 +0.028	8	± 0.100	B-S8-436
8	+0.015 0	12	+0.046 +0.028	10	± 0.100	B-S8-1402
8	+0.018 0	12	+0.046 +0.028	10	0 -0.300	B-S8-381
8	+0.035 +0.013	12	0 -0.018	11	0 -0.200	B-S8-188
8	+0.025 +0.010	12	+0.046 +0.028	11	0 -0.200	B-S8-289
8	+0.015 0	12	+0.046 +0.028	12	± 0.100	B-S8-1311
8	+0.055 +0.040	12	+0.046 +0.028	12	0 -0.100	B-S8-1021
8	+0.035 +0.013	12	+0.041 +0.023	12	± 0.100	B-S8-63
8	+0.035 +0.013	12	+0.041 +0.023	14	± 0.100	B-S8-209
8	+0.035 +0.013	12	+0.041 +0.023	15	0 -0.200	B-S8-73
8	+0.015 +0.008	12	+0.034 +0.023	16	0 -0.100	B-S8-75
8	+0.035 +0.013	12	+0.041 +0.023	18	0 -0.200	B-S8-79
8	+0.015 0	12	+0.046 +0.028	18	± 0.150	B-S8-81
8	+0.015 0	12	+0.046 +0.028	20	± 0.100	B-S8-84
8	+0.022 0	12	+0.046 +0.028	35	± 0.500	B-S8-296
8	+0.015 0	13	+0.046 +0.028	5	± 0.100	B-S8-90
8	+0.035 +0.013	13	+0.041 +0.023	9	± 0.150	B-S8-91
8	+0.035 +0.013	13	+0.041 +0.023	15	0 -0.200	B-S8-93
8	+0.015 0	14	+0.046 +0.028	3.5	± 0.100	B-S8-231
8	+0.035 +0.010	14	+0.046 +0.028	4.1	± 0.100	B-S8-307
8	+0.025 +0.010	14	+0.045 +0.026	16	± 0.100	B-S8-115

d 8~10mm

Bore ϕd	Dimensions mm			Product code		
	Outer diameter ϕD	Length ℓ				
8	+0.017 0	15	+0.045 +0.025	22	± 0.150	B-S8-328
8	+0.017 0	15	+0.045 +0.025	24	± 0.200	B-S8-130
8	+0.015 0	16	+0.036 +0.018	5	0 -0.200	B-S8-132
8	+0.028 +0.005	16	+0.046 +0.028	10	± 0.100	B-S8-234
8	+0.015 0	16	+0.046 +0.028	13	± 0.150	B-S8-376
8	+0.023 +0.008	16	+0.046 +0.028	15	± 0.150	B-S8-137
8	+0.015 0	16	+0.046 +0.028	20	± 0.150	B-S8-258
9	+0.020 +0.005	12	+0.046 +0.028	9	0 -0.100	B-S9-34
9	+0.025 +0.010	12	+0.046 +0.028	13	± 0.050	B-S9-1014
9	+0.015 0	13	+0.046 +0.028	8	± 0.150	B-S9-37
9	+0.015 0	14	+0.046 +0.028	12	± 0.100	B-S9-12
10	+0.015 0	12	+0.046 +0.028	7.8	± 0.150	B-S10-122
10	+0.015 0	13	+0.046 +0.028	8	± 0.100	B-S10-3
10	+0.070 +0.050	14	+0.038 +0.023	4	± 0.100	B-S10-132
10	+0.070 +0.050	14	+0.038 +0.023	5	± 0.100	B-S10-21
10	+0.055 0	14	+0.046 +0.028	5	± 0.100	B-S10-1044
10	+0.018 0	14	+0.046 +0.028	7	± 0.100	B-S10-25
10	+0.015 0	14	+0.046 +0.028	12	± 0.150	B-S10-136
10	+0.015 0	14	+0.046 +0.028	15	± 0.100	S10-144
10	+0.015 0	14	+0.046 +0.028	16	± 0.150	B-S10-42
10	+0.030 +0.010	14	+0.036 +0.018	18	± 0.100	B-S10-44
10	+0.015 0	15	+0.046 +0.028	4	± 0.100	B-S10-1025
10	+0.035 +0.013	15	+0.041 +0.023	19	0 -0.100	B-S10-53
10	+0.015 0	16	+0.046 +0.028	9	± 0.150	B-S10-1050
10	+0.015 0	16	+0.046 +0.028	14	± 0.150	B-S10-170
10	+0.015 0	16	+0.046 +0.028	15	± 0.150	B-S10-60
10	+0.035 +0.020	16	+0.046 +0.028	20	± 0.150	B-S10-125
10	+0.045 +0.027	18	+0.050 +0.032	5	± 0.100	B-S10-1102

Note: Please contact NTN with regard to the type of oil.
The material is copper based (H).

Flange Bearings

d 4mm

Bore ϕd	Dimensions mm					Product code				
	Outer diameter ϕD	Length ℓ	Flange outer diameter ϕF	Flange thickness t						
4	$\begin{matrix} +0.030 \\ +0.010 \end{matrix}$	6	$\begin{matrix} 0 \\ -0.050 \end{matrix}$	2.5	± 0.100	8	± 0.100	1	± 0.100	B-F4-1
4	$\begin{matrix} +0.030 \\ 0 \end{matrix}$	6	$\begin{matrix} -0.020 \\ -0.050 \end{matrix}$	3	± 0.200	$\begin{matrix} 11 \\ 9.5 \end{matrix}$	$\begin{matrix} \pm 0.200 \\ 0 \\ -0.100 \end{matrix}$	1.5	± 0.200	B-F4-2 *
4	$\begin{matrix} +0.030 \\ +0.010 \end{matrix}$	6	$\begin{matrix} 0 \\ -0.050 \end{matrix}$	5	± 0.100	8	± 0.100	1	± 0.100	B-F4-73
4	$\begin{matrix} +0.030 \\ 0 \end{matrix}$	6	$\begin{matrix} -0.020 \\ -0.050 \end{matrix}$	5	± 0.200	10	± 0.200	1.5	± 0.200	B-F4-43
4	$\begin{matrix} +0.030 \\ +0.010 \end{matrix}$	6	$\begin{matrix} 0 \\ -0.050 \end{matrix}$	7	± 0.100	8	± 0.100	1	± 0.100	B-F4-1079
4	$\begin{matrix} +0.038 \\ +0.020 \end{matrix}$	$\begin{matrix} 6 \\ 5.6 \end{matrix}$	$\begin{matrix} 0 \\ -0.018 \\ 0 \\ -0.100 \end{matrix}$	5.9	± 0.100	9	± 0.100	1	± 0.100	B-F4-1045K *
4	$\begin{matrix} +0.030 \\ 0 \end{matrix}$	7	$\begin{matrix} 0 \\ -0.018 \end{matrix}$	2.5	± 0.100	8.2	± 0.100	0.6	± 0.100	B-F4-5
4	$\begin{matrix} +0.030 \\ 0 \end{matrix}$	7	$\begin{matrix} 0 \\ -0.058 \end{matrix}$	3	± 0.300	8.2	± 0.100	0.6	± 0.100	B-F4-50 *
4	$\begin{matrix} +0.050 \\ +0.020 \end{matrix}$	7	$\begin{matrix} 0 \\ -0.050 \end{matrix}$	3	± 0.100	9	± 0.150	0.9	± 0.100	B-F4-6
4	$\begin{matrix} +0.030 \\ 0 \end{matrix}$	7	$\begin{matrix} -0.025 \\ -0.083 \end{matrix}$	3	± 0.300	10	± 0.300	1.5		B-F4-7
4	$\begin{matrix} +0.020 \\ 0 \end{matrix}$	7	$\begin{matrix} 0 \\ -0.020 \end{matrix}$	4.7	± 0.100	9	± 0.100	1.5	± 0.100	B-F4-101
4	$\begin{matrix} +0.050 \\ +0.020 \end{matrix}$	7	$\begin{matrix} -0.010 \\ -0.030 \end{matrix}$	5	± 0.100	9	± 0.100	1	± 0.100	B-F4-93
4	$\begin{matrix} +0.048 \\ 0 \end{matrix}$	7	$\begin{matrix} -0.040 \\ -0.098 \end{matrix}$	6	± 0.100	10	± 0.200	1.5	± 0.100	B-F4-9
4	$\begin{matrix} +0.048 \\ 0 \end{matrix}$	7	$\begin{matrix} -0.025 \\ -0.061 \end{matrix}$	9.5	± 0.200	10	± 0.300	7		B-F4-41
4	$\begin{matrix} +0.012 \\ 0 \end{matrix}$	7	$\begin{matrix} +0.038 \\ +0.023 \end{matrix}$	10	± 0.100	9	± 0.200	1.5	± 0.100	B-F4-49
4	$\begin{matrix} +0.020 \\ 0 \end{matrix}$	$\begin{matrix} 7 \\ 6 \end{matrix}$	$\begin{matrix} 0 \\ -0.020 \\ 0 \\ -0.100 \\ -0.200 \end{matrix}$	4.7	± 0.100	9	± 0.100	1.5	± 0.100	B-F4-102 *
4	$\begin{matrix} +0.048 \\ 0 \end{matrix}$	$\begin{matrix} 7 \\ 6.5 \end{matrix}$	$\begin{matrix} -0.040 \\ -0.098 \\ 0 \\ -0.200 \end{matrix}$	4.5	± 0.100	10	± 0.100	1.5	± 0.100	B-F4-97 *
4	$\begin{matrix} +0.048 \\ 0 \end{matrix}$	$\begin{matrix} 7 \\ 6.5 \end{matrix}$	$\begin{matrix} -0.040 \\ -0.098 \\ 0 \\ -0.200 \end{matrix}$	6	± 0.100	10	± 0.100	1.5	± 0.100	B-F4-10 *
4	$\begin{matrix} +0.030 \\ 0 \end{matrix}$	8	$\begin{matrix} -0.025 \\ -0.083 \end{matrix}$	3	± 0.300	12	± 0.300	1.5		B-F4-40
4	$\begin{matrix} +0.012 \\ 0 \end{matrix}$	8	$\begin{matrix} +0.046 \\ +0.028 \end{matrix}$	3.5	± 0.100	10	± 0.200	1	± 0.100	B-F4-36
4	$\begin{matrix} +0.018 \\ 0 \end{matrix}$	8	$\begin{matrix} +0.038 \\ +0.023 \end{matrix}$	4	± 0.100	11	± 0.100	1.5	$\begin{matrix} -0.100 \\ -0.200 \end{matrix}$	B-F4-15
4	$\begin{matrix} +0.012 \\ +0.002 \end{matrix}$	8	$\begin{matrix} +0.046 \\ +0.028 \end{matrix}$	5	± 0.100	10	± 0.100	1	$\begin{matrix} 0 \\ -0.100 \end{matrix}$	B-F4-152
4	$\begin{matrix} +0.012 \\ 0 \end{matrix}$	8	$\begin{matrix} +0.038 \\ +0.023 \end{matrix}$	5	± 0.100	12	± 0.100	2	$\begin{matrix} 0 \\ -0.100 \end{matrix}$	B-F4-18
4	$\begin{matrix} +0.048 \\ 0 \end{matrix}$	8	$\begin{matrix} -0.013 \\ -0.049 \end{matrix}$	5.4	± 0.300	18	± 0.200	2.2		B-F4-35
4	$\begin{matrix} +0.045 \\ +0.033 \end{matrix}$	8	$\begin{matrix} +0.038 \\ +0.023 \end{matrix}$	6	± 0.150	12	± 0.140	2	± 0.200	B-F4-21
4	$\begin{matrix} +0.012 \\ 0 \end{matrix}$	8	$\begin{matrix} +0.038 \\ +0.023 \end{matrix}$	10	± 0.100	12	± 0.100	2	± 0.050	B-F4-33
4	$\begin{matrix} +0.030 \\ 0 \end{matrix}$	$\begin{matrix} 8 \\ 6.8 \end{matrix}$	$\begin{matrix} -0.025 \\ -0.083 \\ 0 \\ -0.090 \end{matrix}$	8	± 0.200	12	± 0.140	2	± 0.200	B-F4-57 *

d 4~5mm

Bore ϕd	Dimensions mm					Product code				
	Outer diameter ϕD	Length ℓ	Flange outer diameter ϕF	Flange thickness t						
4	$\begin{matrix} +0.060 \\ +0.045 \end{matrix}$	$\begin{matrix} 8 \\ 7 \end{matrix}$	$\begin{matrix} +0.032 \\ +0.023 \\ 0 \\ -0.100 \end{matrix}$	6	± 0.100	10	± 0.100	1.5	± 0.200	B-F4-42 *
4	$\begin{matrix} +0.080 \\ +0.050 \end{matrix}$	$\begin{matrix} 8 \\ 7 \end{matrix}$	$\begin{matrix} -0.020 \\ -0.070 \\ 0 \\ -0.100 \end{matrix}$	6	± 0.300	12	± 0.300	2	± 0.300	B-F4-1016K *
4	$\begin{matrix} +0.040 \\ +0.020 \end{matrix}$	9	$\begin{matrix} +0.050 \\ +0.030 \end{matrix}$	6	± 0.100	12	± 0.100	2	± 0.100	B-F4-145
4	$\begin{matrix} +0.040 \\ +0.020 \end{matrix}$	9	$\begin{matrix} +0.050 \\ +0.030 \end{matrix}$	8	± 0.100	12	± 0.100	2	± 0.100	B-F4-27
4	$\begin{matrix} +0.021 \\ +0.015 \end{matrix}$	10	$\begin{matrix} +0.045 \\ +0.030 \end{matrix}$	4	± 0.100	12	± 0.100	1.5	± 0.100	B-F4-59 *
4	$\begin{matrix} +0.048 \\ 0 \end{matrix}$	10	$\begin{matrix} -0.013 \\ -0.049 \end{matrix}$	9.6	± 0.300	18	± 0.200	1.9		B-F4-147
4	$\begin{matrix} +0.038 \\ +0.020 \end{matrix}$	$\begin{matrix} 11 \\ 10.5 \end{matrix}$	$\begin{matrix} 0 \\ -0.027 \\ 0 \\ -0.100 \end{matrix}$	3.5	± 0.100	13	± 0.100	1	± 0.100	B-F4-67 *
4	$\begin{matrix} +0.020 \\ +0.010 \end{matrix}$	9	$\begin{matrix} 0 \\ -0.010 \end{matrix}$	4.3	$\begin{matrix} +0.100 \\ 0 \end{matrix}$	11.13	$\begin{matrix} 0 \\ -0.050 \end{matrix}$	2.9	± 0.050	B-F4-53 *
4	$\begin{matrix} +0.020 \\ +0.010 \end{matrix}$	9	$\begin{matrix} 0 \\ -0.010 \end{matrix}$	4.3	$\begin{matrix} +0.100 \\ 0 \end{matrix}$	$\begin{matrix} 17 \\ 11.15 \end{matrix}$	$\begin{matrix} 0 \\ -0.050 \end{matrix}$	2.2	± 0.100	B-F4-60 *
4	$\begin{matrix} +0.020 \\ +0.010 \end{matrix}$	9	$\begin{matrix} 0 \\ -0.010 \end{matrix}$	4.9	$\begin{matrix} +0.100 \\ 0 \end{matrix}$	11.13	$\begin{matrix} 0 \\ -0.050 \end{matrix}$	2.9	± 0.050	B-F4-54 *
5	$\begin{matrix} +0.050 \\ 0 \end{matrix}$	7	$\begin{matrix} 0 \\ -0.050 \end{matrix}$	2.5	± 0.100	8	± 0.100	1	± 0.200	B-F5-1093
5	$\begin{matrix} +0.030 \\ 0 \end{matrix}$	7	$\begin{matrix} 0 \\ -0.022 \end{matrix}$	3	± 0.100	8	± 0.100	1		B-F5-1094
5	$\begin{matrix} +0.075 \\ 0 \end{matrix}$	$\begin{matrix} 7.92 \\ 7.5 \end{matrix}$	$\begin{matrix} -0.090 \\ 0 \\ -0.100 \end{matrix}$	3		10	± 0.500	1	± 0.150	B-F5-135K *
5	$\begin{matrix} +0.075 \\ 0 \end{matrix}$	$\begin{matrix} 7.92 \\ 7.5 \end{matrix}$	$\begin{matrix} -0.090 \\ 0 \\ -0.100 \end{matrix}$	5		10	± 0.500	1	± 0.150	B-F5-67 *
5	$\begin{matrix} +0.038 \\ +0.020 \end{matrix}$	8	$\begin{matrix} +0.041 \\ +0.023 \end{matrix}$	3	± 0.100	10	± 0.100	1	$\begin{matrix} 0 \\ -0.050 \end{matrix}$	B-F5-100
5	$\begin{matrix} +0.038 \\ +0.020 \end{matrix}$	8	$\begin{matrix} +0.041 \\ +0.023 \end{matrix}$	3	± 0.100	10	± 0.100	1	$\begin{matrix} 0 \\ -0.050 \end{matrix}$	B-F5-1056
5	$\begin{matrix} +0.038 \\ +0.020 \end{matrix}$	8	$\begin{matrix} +0.041 \\ +0.023 \end{matrix}$	3	± 0.100	10	± 0.100	1	$\begin{matrix} 0 \\ -0.050 \end{matrix}$	B-F5-53
5	$\begin{matrix} +0.050 \\ +0.020 \end{matrix}$	8	$\begin{matrix} +0.028 \\ +0.019 \end{matrix}$	3.5	± 0.100	11	± 0.100	1.5	± 0.100	B-F5-2
5	$\begin{matrix} +0.022 \\ +0.010 \end{matrix}$	8	$\begin{matrix} +0.034 \\ +0.019 \end{matrix}$	4	± 0.200	9	± 0.200	1	$\begin{matrix} 0 \\ -0.100 \end{matrix}$	B-F5-77
5	$\begin{matrix} +0.012 \\ 0 \end{matrix}$	8	$\begin{matrix} +0.020 \\ 0 \end{matrix}$	5	± 0.100	10	± 0.150	0.9	± 0.100	B-F5-4
5	$\begin{matrix} +0.025 \\ +0.010 \end{matrix}$	8	$\begin{matrix} +0.038 \\ +0.023 \end{matrix}$	5	± 0.100	11	± 0.200	1	± 0.100	B-F5-5
5	$\begin{matrix} +0.025 \\ +0.013 \end{matrix}$	8	$\begin{matrix} +0.038 \\ +0.023 \end{matrix}$	6	± 0.100	11	± 0.150	1.5	± 0.100	B-F5-7
5	$\begin{matrix} +0.025 \\ +0.010 \end{matrix}$	8	$\begin{matrix} +0.038 \\ +0.023 \end{matrix}$	7	± 0.100	11	± 0.100	1	± 0.100	B-F5-72
5	$\begin{matrix} +0.025 \\ +0.010 \end{matrix}$	8	$\begin{matrix} +0.038 \\ +0.023 \end{matrix}$	11	± 0.150	11	± 0.200	1	± 0.100	B-F5-1081
5	$\begin{matrix} +0.018 \\ 0 \end{matrix}$	9	$\begin{matrix} 0 \\ -0.018 \end{matrix}$	4	± 0.100	11	± 0.100	1.5	± 0.100	B-F5-10

Note: Items indicated with an asterisk (*) have a special shape. Please contact NTN for details.
Please contact NTN with regard to the type of oil.
The material is copper based (H).

Flange Bearings

d 5~6mm

Bore ϕd	Dimensions mm					Product code				
	Outer diameter ϕD	Length ℓ	Flange outer diameter ϕF	Flange thickness t						
5	$\begin{matrix} +0.012 \\ 0 \end{matrix}$	9	$\begin{matrix} 0 \\ -0.018 \end{matrix}$	4	± 0.100	11	± 0.100	1.5	± 0.100	B-F5-108
5	$\begin{matrix} +0.007 \\ +0.002 \end{matrix}$	9	$\begin{matrix} 0 \\ -0.015 \end{matrix}$	4	± 0.100	11	± 0.200	2.5	± 0.100	B-F5-116 ※
5	$\begin{matrix} +0.012 \\ 0 \end{matrix}$	9	$\begin{matrix} +0.038 \\ +0.023 \end{matrix}$	4.3	± 0.100	11	± 0.100	0.8	± 0.200	B-F5-11
5	$\begin{matrix} +0.012 \\ 0 \end{matrix}$	9	$\begin{matrix} +0.038 \\ +0.023 \end{matrix}$	5	± 0.100	11	± 0.100	0.8	± 0.100	B-F5-85
5	$\begin{matrix} +0.018 \\ +0.003 \end{matrix}$	$\begin{matrix} 9 \\ 8 \end{matrix}$	$\begin{matrix} +0.045 \\ +0.030 \\ -0.050 \\ -0.200 \end{matrix}$	5	± 0.100	11	± 0.100	1.5	± 0.100	B-F5-120 ※
5	$\begin{matrix} +0.018 \\ +0.003 \end{matrix}$	$\begin{matrix} 9 \\ 8 \end{matrix}$	$\begin{matrix} +0.045 \\ +0.030 \\ -0.050 \\ -0.200 \end{matrix}$	9.5	± 0.150	11	± 0.200	1.5	± 0.100	B-F5-13 ※
5	$\begin{matrix} +0.020 \\ +0.005 \end{matrix}$	10	$\begin{matrix} +0.038 \\ +0.023 \end{matrix}$	4	± 0.100	12	± 0.100	1	± 0.100	B-F5-30
5	$\begin{matrix} +0.014 \\ +0.005 \end{matrix}$	10	$\begin{matrix} +0.019 \\ +0.010 \end{matrix}$	5.5	± 0.100	13	± 0.100	1	± 0.100	B-F5-81
5	$\begin{matrix} +0.014 \\ +0.005 \end{matrix}$	10	$\begin{matrix} +0.019 \\ +0.010 \end{matrix}$	8	± 0.150	13	± 0.100	1	± 0.100	B-F5-15
5	$\begin{matrix} +0.048 \\ 0 \end{matrix}$	10	$\begin{matrix} -0.013 \\ -0.049 \end{matrix}$	8	± 0.300	18	± 0.200	2	± 0.150	B-F5-35
5	$\begin{matrix} +0.030 \\ +0.015 \end{matrix}$	11	$\begin{matrix} +0.050 \\ +0.020 \end{matrix}$	4	± 0.100	13	± 0.100	0.8	± 0.200	B-F5-18
5	$\begin{matrix} +0.028 \\ +0.005 \end{matrix}$	11	$\begin{matrix} +0.046 \\ +0.028 \end{matrix}$	13	± 0.100	15	± 0.100	2	± 0.200	B-F5-107
5	$\begin{matrix} +0.016 \\ +0.004 \end{matrix}$	$\begin{matrix} 11 \\ 10.4 \end{matrix}$	$\begin{matrix} +0.046 \\ +0.028 \\ -0.020 \\ -0.070 \end{matrix}$	5	± 0.100	$\begin{matrix} 13 \\ 11.4 \end{matrix}$	$\begin{matrix} \pm 0.100 \\ \pm 0.100 \end{matrix}$	2	$\begin{matrix} 0 \\ -0.100 \end{matrix}$	B-F5-1008K ※
5	$\begin{matrix} +0.016 \\ +0.004 \end{matrix}$	$\begin{matrix} 11 \\ 10.4 \end{matrix}$	$\begin{matrix} +0.046 \\ +0.028 \\ -0.020 \\ -0.070 \end{matrix}$	5	± 0.100	$\begin{matrix} 13 \\ 11.4 \end{matrix}$	$\begin{matrix} \pm 0.100 \\ \pm 0.100 \end{matrix}$	2	$\begin{matrix} 0 \\ -0.100 \end{matrix}$	B-F5-66 ※
5	$\begin{matrix} +0.013 \\ +0.008 \\ 5.4 \end{matrix}$	$\begin{matrix} 7.8 \\ 0 \end{matrix}$	$\begin{matrix} +0.010 \\ 0 \end{matrix}$	2.3		$\begin{matrix} 8.8 \\ -0.100 \end{matrix}$		0.9	± 0.050	B-F5-48 ※
6	$\begin{matrix} +0.048 \\ 0 \end{matrix}$	8	$\begin{matrix} 0 \\ -0.058 \end{matrix}$	2.6	± 0.200	10	± 0.300	1	± 0.100	B-F6-1272
6	$\begin{matrix} +0.120 \\ 0 \end{matrix}$	8	$\begin{matrix} -0.013 \\ -0.103 \end{matrix}$	3	± 0.300	10	± 0.300	1	± 0.300	B-F6-1247
6	$\begin{matrix} +0.030 \\ +0.010 \end{matrix}$	8	$\begin{matrix} 0 \\ -0.050 \end{matrix}$	3	± 0.100	10	± 0.100	1	± 0.100	B-F6-3
6	$\begin{matrix} +0.120 \\ 0 \end{matrix}$	8	$\begin{matrix} -0.010 \\ -0.030 \end{matrix}$	4	± 0.500	10	± 0.500	1	± 0.500	B-F6-1068
6	$\begin{matrix} +0.038 \\ +0.020 \end{matrix}$	8	$\begin{matrix} -0.013 \\ -0.035 \end{matrix}$	4	± 0.100	10	± 0.200	1	± 0.100	B-F6-1099
6	$\begin{matrix} +0.030 \\ +0.010 \end{matrix}$	8	$\begin{matrix} 0 \\ -0.050 \end{matrix}$	4	± 0.100	10	± 0.100	1	± 0.100	B-F6-1292
6	$\begin{matrix} +0.012 \\ 0 \end{matrix}$	8	$\begin{matrix} 0 \\ -0.015 \end{matrix}$	5	± 0.100	12	± 0.100	1	± 0.200	B-F6-121
6	$\begin{matrix} +0.015 \\ 0 \end{matrix}$	8	$\begin{matrix} +0.038 \\ +0.023 \end{matrix}$	5.8	± 0.150	12	± 0.100	2	± 0.100	B-F6-92
6	$\begin{matrix} +0.030 \\ +0.010 \end{matrix}$	8	$\begin{matrix} 0 \\ -0.050 \end{matrix}$	6	± 0.100	10	± 0.100	1	± 0.100	B-F6-1111
6	$\begin{matrix} +0.020 \\ 0 \end{matrix}$	8	$\begin{matrix} -0.008 \\ -0.030 \end{matrix}$	9	± 0.200	10	± 0.200	1	± 0.100	B-F6-1122
6	$\begin{matrix} +0.030 \\ +0.010 \end{matrix}$	8	$\begin{matrix} 0 \\ -0.043 \end{matrix}$	10	± 0.150	10	± 0.100	1	± 0.100	B-F6-306
6	$\begin{matrix} +0.035 \\ +0.025 \end{matrix}$	9	$\begin{matrix} +0.038 \\ +0.023 \end{matrix}$	4	$\begin{matrix} 0 \\ -0.100 \end{matrix}$	11	± 0.100	1	$\begin{matrix} 0 \\ -0.100 \end{matrix}$	B-F6-180
6	$\begin{matrix} +0.018 \\ 0 \end{matrix}$	9	$\begin{matrix} +0.034 \\ +0.019 \end{matrix}$	4	± 0.100	11	± 0.100	1	± 0.100	B-F6-6

d 6mm

Bore ϕd	Dimensions mm					Product code				
	Outer diameter ϕD	Length ℓ	Flange outer diameter ϕF	Flange thickness t						
6	$\begin{matrix} +0.012 \\ 0 \end{matrix}$	9	$\begin{matrix} +0.030 \\ +0.015 \end{matrix}$	5	± 0.100	12	± 0.100	1.5	± 0.100	B-F6-126
6	$\begin{matrix} +0.012 \\ 0 \end{matrix}$	9	$\begin{matrix} +0.038 \\ +0.023 \end{matrix}$	5	± 0.100	12	± 0.300	2	± 0.200	B-F6-282
6	$\begin{matrix} +0.012 \\ 0 \end{matrix}$	9	$\begin{matrix} +0.030 \\ +0.015 \end{matrix}$	6	± 0.100	12	± 0.100	1.5	± 0.100	B-F6-168
6	$\begin{matrix} +0.018 \\ 0 \end{matrix}$	9	$\begin{matrix} +0.034 \\ +0.019 \end{matrix}$	7	± 0.100	11	± 0.100	1	± 0.100	B-F6-8
6	$\begin{matrix} +0.012 \\ 0 \end{matrix}$	9	$\begin{matrix} +0.028 \\ +0.019 \end{matrix}$	7	± 0.150	12	± 0.100	2	± 0.200	B-F6-289
6	$\begin{matrix} +0.012 \\ 0 \end{matrix}$	9	$\begin{matrix} +0.005 \\ -0.010 \end{matrix}$	8	± 0.200	12	± 0.200	1.5	± 0.200	B-F6-229
6	$\begin{matrix} +0.018 \\ 0 \end{matrix}$	9	$\begin{matrix} +0.034 \\ +0.019 \end{matrix}$	9	$\begin{matrix} +0.200 \\ 0 \end{matrix}$	11	± 0.200	1	$\begin{matrix} 0 \\ -0.100 \end{matrix}$	B-F6-10
6	$\begin{matrix} +0.032 \\ +0.020 \end{matrix}$	9	$\begin{matrix} +0.038 \\ +0.023 \end{matrix}$	10	± 0.100	11	± 0.100	1	$\begin{matrix} 0 \\ -0.200 \end{matrix}$	B-F6-1324
6	$\begin{matrix} +0.030 \\ 0 \end{matrix}$	$\begin{matrix} 9 \\ 7.8 \end{matrix}$	$\begin{matrix} -0.025 \\ -0.083 \\ 0 \\ -0.090 \end{matrix}$	5	± 0.200	11	± 0.200	2	± 0.200	B-F6-283 ※
6	$\begin{matrix} +0.030 \\ 0 \end{matrix}$	$\begin{matrix} 9 \\ 8 \end{matrix}$	$\begin{matrix} -0.013 \\ -0.036 \\ 0 \\ -0.058 \end{matrix}$	5.5	± 0.300	13	± 0.300	1.5	± 0.300	B-F6-84 ※
6	$\begin{matrix} +0.050 \\ +0.020 \end{matrix}$	$\begin{matrix} 9 \\ 8 \end{matrix}$	$\begin{matrix} -0.013 \\ -0.071 \\ 0 \\ -0.100 \end{matrix}$	8	± 0.100	10	± 0.200	1.5	± 0.080	B-F6-251 ※
6	$\begin{matrix} +0.012 \\ 0 \end{matrix}$	$\begin{matrix} 9 \\ 8.5 \end{matrix}$	$\begin{matrix} +0.021 \\ +0.006 \\ 0 \\ -0.100 \end{matrix}$	3	± 0.100	12	± 0.100	1.5	$\begin{matrix} 0 \\ -0.200 \end{matrix}$	B-F6-1123K ※
6	$\begin{matrix} +0.012 \\ 0 \end{matrix}$	$\begin{matrix} 9 \\ 8.5 \end{matrix}$	$\begin{matrix} +0.021 \\ +0.006 \\ 0 \\ -0.100 \end{matrix}$	5.5	± 0.200	12	± 0.100	1.5	$\begin{matrix} 0 \\ -0.200 \end{matrix}$	B-F6-7 ※
6	$\begin{matrix} +0.030 \\ 0 \end{matrix}$	$\begin{matrix} 9.6 \\ 8 \end{matrix}$	$\begin{matrix} 0 \\ -0.040 \\ 0 \\ -0.100 \end{matrix}$	10	$\begin{matrix} 0 \\ -0.200 \end{matrix}$	12	± 0.100	1.5	$\begin{matrix} 0 \\ -0.200 \end{matrix}$	B-F6-185 ※
6	$\begin{matrix} +0.012 \\ 0 \end{matrix}$	10	$\begin{matrix} +0.038 \\ +0.023 \end{matrix}$	2.5	± 0.100	12	± 0.100	1	± 0.100	B-F6-181
6	$\begin{matrix} +0.012 \\ 0 \end{matrix}$	10	$\begin{matrix} +0.038 \\ +0.023 \end{matrix}$	3.5	± 0.100	12	± 0.100	1	± 0.100	B-F6-14
6	$\begin{matrix} +0.045 \\ +0.033 \end{matrix}$	10	$\begin{matrix} +0.038 \\ +0.023 \end{matrix}$	3.8	± 0.200	14	± 0.140	1	± 0.200	B-F6-116
6	$\begin{matrix} +0.012 \\ 0 \end{matrix}$	10	$\begin{matrix} +0.038 \\ +0.023 \end{matrix}$	4	± 0.100	12	± 0.100	1.5	$\begin{matrix} 0 \\ -0.100 \end{matrix}$	B-F6-15
6	$\begin{matrix} +0.048 \\ 0 \end{matrix}$	10	$\begin{matrix} -0.025 \\ -0.061 \end{matrix}$	4	± 0.200	14	± 0.200	1	± 0.200	B-F6-182
6	$\begin{matrix} +0.030 \\ 0 \end{matrix}$	10	$\begin{matrix} -0.025 \\ -0.061 \end{matrix}$	4	± 0.100	14	± 0.140	2	± 0.200	B-F6-18
6	$\begin{matrix} +0.030 \\ 0 \end{matrix}$	10	$\begin{matrix} 0 \\ -0.036 \end{matrix}$	4.5	$\begin{matrix} 0 \\ -0.100 \end{matrix}$	12	± 0.200	1	± 0.100	B-F6-178
6	$\begin{matrix} +0.020 \\ 0 \end{matrix}$	10	$\begin{matrix} 0 \\ -0.020 \end{matrix}$	4.5	$\begin{matrix} 0 \\ -0.200 \end{matrix}$	12	± 0.200	2	$\begin{matrix} 0 \\ -0.100 \end{matrix}$	B-F6-20
6	$\begin{matrix} +0.030 \\ +0.015 \end{matrix}$	10	$\begin{matrix} +0.038 \\ +0.023 \end{matrix}$	5	± 0.100	12	± 0.100	1	± 0.100	B-F6-163
6	$\begin{matrix} +0.012 \\ 0 \end{matrix}$	10	$\begin{matrix} +0.038 \\ +0.023 \end{matrix}$	5	± 0.100	12	± 0.100	2	± 0.100	B-F6-24
6	$\begin{matrix} +0.078 \\ +0.030 \end{matrix}$	10	$\begin{matrix} 0 \\ -0.058 \end{matrix}$	5	± 0.100	14	$\begin{matrix} 0 \\ -0.200 \end{matrix}$	1.5	$\begin{matrix} 0 \\ -0.300 \end{matrix}$	B-F6-128
6	$\begin{matrix} +0.045 \\ +0.033 \end{matrix}$	10	$\begin{matrix} +0.038 \\ +0.023 \end{matrix}$	5	± 0.200	14	± 0.140	2	± 0.200	B-F6-106
6	$\begin{matrix} +0.025 \\ 0 \end{matrix}$	10	$\begin{matrix} 0 \\ -0.015 \end{matrix}$	6	± 0.100	12	± 0.120	2	± 0.100	B-F6-1112

Note: Items indicated with an asterisk (*) have a special shape. Please contact NTN for details.
Please contact NTN with regard to the type of oil.
The material is copper based (H).

Flange Bearings

d 6mm

Bore ϕd	Dimensions mm					Product code
	Outer diameter ϕD	Length ℓ	Flange outer diameter ϕF	Flange thickness t		
6 $\begin{matrix} +0.048 \\ 0 \end{matrix}$	10 $\begin{matrix} -0.025 \\ -0.061 \end{matrix}$	6 ± 0.200	14 ± 0.200	1 ± 0.200		B-F6-183
6 $\begin{matrix} +0.045 \\ +0.033 \end{matrix}$	10 $\begin{matrix} +0.038 \\ +0.023 \end{matrix}$	6 ± 0.220	14 ± 0.140	2 ± 0.200		B-F6-30
6 $\begin{matrix} +0.012 \\ 0 \end{matrix}$	10 $\begin{matrix} +0.038 \\ +0.023 \end{matrix}$	6.5 ± 0.100	12 ± 0.100	1.5 $\begin{matrix} 0 \\ -0.100 \end{matrix}$		B-F6-130
6 $\begin{matrix} +0.025 \\ 0 \end{matrix}$	10 $\begin{matrix} 0 \\ -0.015 \end{matrix}$	7 ± 0.100	12 ± 0.120	2 ± 0.100		B-F6-35
6 $\begin{matrix} +0.012 \\ 0 \end{matrix}$	10 $\begin{matrix} +0.046 \\ +0.028 \end{matrix}$	7 ± 0.150	14 ± 0.100	2 ± 0.100		B-F6-36
6 $\begin{matrix} +0.050 \\ +0.020 \end{matrix}$	10 $\begin{matrix} 0 \\ -0.050 \end{matrix}$	7.5 $\begin{matrix} 0 \\ -0.300 \end{matrix}$	14 ± 0.100	2 $\begin{matrix} 0 \\ -0.100 \end{matrix}$		B-F6-269 ※
6 $\begin{matrix} +0.012 \\ 0 \end{matrix}$	10 $\begin{matrix} +0.038 \\ +0.023 \end{matrix}$	8 ± 0.100	12 ± 0.100	1.5 ± 0.100		B-F6-1273
6 $\begin{matrix} +0.015 \\ 0 \end{matrix}$	10 $\begin{matrix} +0.038 \\ +0.023 \end{matrix}$	8 ± 0.100	14 ± 0.200	1 ± 0.050		B-F6-40
6 $\begin{matrix} +0.035 \\ +0.015 \end{matrix}$	10 $\begin{matrix} +0.046 \\ +0.028 \end{matrix}$	8 ± 0.150	14 ± 0.100	2 ± 0.200		B-F6-41
6 $\begin{matrix} +0.012 \\ 0 \end{matrix}$	10 $\begin{matrix} +0.046 \\ +0.028 \end{matrix}$	9 ± 0.150	14 ± 0.100	2 ± 0.100		B-F6-46
6 $\begin{matrix} +0.035 \\ +0.015 \end{matrix}$	10 $\begin{matrix} +0.046 \\ +0.028 \end{matrix}$	9 ± 0.100	14 ± 0.100	2 $\begin{matrix} 0 \\ -0.050 \end{matrix}$		B-F6-47
6 $\begin{matrix} +0.015 \\ 0 \end{matrix}$	10 $\begin{matrix} +0.046 \\ +0.028 \end{matrix}$	10 ± 0.150	14 ± 0.100	2 ± 0.100		B-F6-1035
6 $\begin{matrix} +0.050 \\ 0 \end{matrix}$	10 $\begin{matrix} -0.020 \\ -0.050 \\ 8 \\ -0.100 \end{matrix}$	4.5 ± 0.100	12 ± 0.200	3		B-F6-228 ※
6 $\begin{matrix} +0.070 \\ +0.020 \end{matrix}$	10 $\begin{matrix} -0.025 \\ -0.061 \\ 8 \\ -0.170 \end{matrix}$	4.5 $\begin{matrix} 0 \\ -0.300 \end{matrix}$	14 ± 0.100	1.5 $\begin{matrix} 0 \\ -0.100 \end{matrix}$		B-F6-270 ※
6 $\begin{matrix} +0.060 \\ +0.010 \end{matrix}$	10 $\begin{matrix} -0.010 \\ -0.050 \\ 8 \\ -0.100 \end{matrix}$	6 ± 0.200	12 ± 0.300	2 $\begin{matrix} 0 \\ -0.200 \end{matrix}$		B-F6-1201K ※
6 $\begin{matrix} +0.070 \\ +0.020 \end{matrix}$	10 $\begin{matrix} -0.025 \\ -0.061 \\ 8 \\ -0.170 \end{matrix}$	6 $\begin{matrix} 0 \\ -0.300 \end{matrix}$	14 ± 0.100	1.5 $\begin{matrix} 0 \\ -0.100 \end{matrix}$		B-F6-29 ※
6 $\begin{matrix} +0.050 \\ +0.020 \end{matrix}$	10 $\begin{matrix} -0.025 \\ -0.047 \\ 8 \\ -0.180 \end{matrix}$	7 ± 0.150	12 ± 0.150	1 ± 0.100		B-F6-34 ※
6 $\begin{matrix} +0.030 \\ +0.010 \end{matrix}$	10 $\begin{matrix} -0.010 \\ -0.030 \\ 8 \\ -0.150 \end{matrix}$	7 ± 0.100	12 ± 0.200	1 ± 0.100		B-F6-83 ※
6 $\begin{matrix} +0.030 \\ +0.010 \end{matrix}$	10 $\begin{matrix} -0.010 \\ -0.030 \\ 8 \\ -0.150 \end{matrix}$	8 ± 0.100	12 ± 0.200	1 ± 0.100		B-F6-364K ※
6 $\begin{matrix} +0.050 \\ +0.020 \end{matrix}$	10 $\begin{matrix} -0.025 \\ -0.047 \\ 8 \\ -0.180 \end{matrix}$	9 ± 0.150	12 ± 0.150	1 ± 0.100		B-F6-1064K ※
6 $\begin{matrix} +0.030 \\ 0 \end{matrix}$	10 $\begin{matrix} -0.025 \\ -0.083 \\ 8.8 \\ -0.090 \end{matrix}$	3.5 ± 0.500	12 ± 0.500	1.5 $\begin{matrix} +0.100 \\ -0.200 \end{matrix}$		B-F6-78 ※
6 $\begin{matrix} +0.030 \\ 0 \end{matrix}$	10 $\begin{matrix} -0.025 \\ -0.083 \\ 8.8 \\ -0.090 \end{matrix}$	4 ± 0.200	14 ± 0.140	2 ± 0.200		B-F6-112 ※

d 6mm

Bore ϕd	Dimensions mm					Product code
	Outer diameter ϕD	Length ℓ	Flange outer diameter ϕF	Flange thickness t		
6 $\begin{matrix} +0.030 \\ 0 \end{matrix}$	10 $\begin{matrix} -0.025 \\ -0.083 \\ 8.8 \\ -0.090 \end{matrix}$	6 ± 0.200	14 ± 0.140	2 ± 0.200		B-F6-1187K ※
6 $\begin{matrix} +0.030 \\ 0 \end{matrix}$	10 $\begin{matrix} -0.025 \\ -0.083 \\ 8.8 \\ -0.090 \end{matrix}$	8 ± 0.200	14 ± 0.135	2 ± 0.200		B-F6-45 ※
6 $\begin{matrix} +0.030 \\ 0 \end{matrix}$	10 $\begin{matrix} -0.025 \\ -0.083 \\ 8.8 \\ -0.090 \end{matrix}$	12 ± 0.200	14 ± 0.300	2 ± 0.200		B-F6-104 ※
6 $\begin{matrix} +0.030 \\ 0 \end{matrix}$	10 $\begin{matrix} \pm 0.200 \\ 8.8 \\ -0.090 \end{matrix}$	12 ± 0.200	14 ± 0.200	2 ± 0.200		B-F6-88 ※
6 $\begin{matrix} +0.012 \\ 0 \end{matrix}$	10 $\begin{matrix} +0.038 \\ +0.023 \\ 9 \\ -0.100 \end{matrix}$	4 ± 0.100	12 ± 0.150	1.5 ± 0.100		B-F6-16 ※
6 $\begin{matrix} +0.012 \\ 0 \end{matrix}$	10 $\begin{matrix} +0.038 \\ +0.023 \\ 9 \\ -0.100 \end{matrix}$	6 ± 0.100	12 ± 0.150	1.5 ± 0.100		B-F6-98 ※
6 $\begin{matrix} +0.022 \\ +0.010 \end{matrix}$	11 $\begin{matrix} +0.005 \\ -0.010 \end{matrix}$	4 ± 0.100	$\begin{matrix} 13.5 \pm 0.100 \\ 12.25 \end{matrix}$	1.4 ± 0.050		B-F6-123 ※
6 $\begin{matrix} +0.022 \\ +0.010 \end{matrix}$	11 $\begin{matrix} +0.041 \\ +0.023 \end{matrix}$	5 ± 0.100	14 ± 0.100	2 ± 0.100		B-F6-57
6 $\begin{matrix} +0.022 \\ +0.010 \end{matrix}$	11 $\begin{matrix} 0 \\ -0.025 \end{matrix}$	7 ± 0.150	14 ± 0.100	2 ± 0.100		B-F6-58
6 $\begin{matrix} +0.025 \\ +0.003 \end{matrix}$	11 $\begin{matrix} +0.040 \\ +0.025 \end{matrix}$	10 ± 0.150	14 ± 0.100	3 ± 0.100		B-F6-60
6 $\begin{matrix} +0.024 \\ +0.008 \end{matrix}$	11 $\begin{matrix} 0 \\ -0.020 \\ 10 \\ -0.050 \end{matrix}$	3 ± 0.100	13 ± 0.100	1 ± 0.100		B-F6-169 ※
6 $\begin{matrix} +0.020 \\ +0.010 \end{matrix}$	12 $\begin{matrix} +0.019 \\ +0.001 \end{matrix}$	4 ± 0.100	12.7 $\begin{matrix} 0 \\ -0.300 \end{matrix}$	1 $\begin{matrix} 0 \\ -0.150 \end{matrix}$		B-F6-171
6 $\begin{matrix} +0.050 \\ +0.010 \end{matrix}$	12 $\begin{matrix} 0 \\ -0.050 \end{matrix}$	4 ± 0.200	15.8 $\begin{matrix} 0 \\ -0.300 \end{matrix}$	1.5 ± 0.100		B-F6-176 ※
6 $\begin{matrix} +0.030 \\ 0 \end{matrix}$	12 $\begin{matrix} -0.016 \\ -0.043 \end{matrix}$	5 ± 0.250	16 ± 0.250	2 ± 0.250		B-F6-64
6 $\begin{matrix} +0.030 \\ +0.015 \end{matrix}$	12 $\begin{matrix} +0.040 \\ +0.025 \end{matrix}$	5.3 ± 0.050	14 $\begin{matrix} +0.040 \\ +0.010 \end{matrix}$	1		B-F6-1075
6 $\begin{matrix} +0.030 \\ 0 \end{matrix}$	12 $\begin{matrix} -0.032 \\ -0.102 \end{matrix}$	10 $\begin{matrix} 0 \\ -0.400 \end{matrix}$	16 ± 0.140	2 ± 0.200		B-F6-288
6 $\begin{matrix} +0.012 \\ 0 \end{matrix}$	12 $\begin{matrix} +0.021 \\ +0.006 \\ 8 \\ -0.150 \end{matrix}$	5.5	16 ± 0.100	1 ± 0.050		B-F6-235 ※
6 $\begin{matrix} +0.012 \\ 0 \end{matrix}$	12 $\begin{matrix} -0.050 \\ -0.077 \end{matrix}$	5 $\begin{matrix} 0 \\ -0.100 \end{matrix}$	$\begin{matrix} 16 \pm 0.250 \\ 14.5 \pm 0.150 \end{matrix}$	2 ± 0.100		B-F6-63 ※

Note: Items indicated with an asterisk (*) have a special shape. Please contact NTN for details.
Please contact NTN with regard to the type of oil.
The material is copper based (H).

Flange Bearings

d 7~8mm

Bore ϕd	Dimensions mm				Product code		
	Outer diameter ϕD	Length ℓ	Flange outer diameter ϕF	Flange thickness t			
7	$\begin{matrix} +0.015 \\ 0 \end{matrix}$	10	$\begin{matrix} +0.038 \\ +0.023 \end{matrix}$	6 ± 0.100	13 ± 0.100	1.3 ± 0.100	B-F7-1
7	$\begin{matrix} +0.036 \\ 0 \end{matrix}$	10	$\begin{matrix} -0.025 \\ -0.061 \end{matrix}$	8 ± 0.100	12 ± 0.100	2 ± 0.100	B-F7-3
7	$\begin{matrix} +0.040 \\ +0.020 \end{matrix}$	12	$\begin{matrix} 0 \\ -0.020 \end{matrix}$	12 ± 0.100	15 ± 0.100	3 ± 0.100	B-F7-5
7	$\begin{matrix} +0.015 \\ 0 \end{matrix}$	13	$\begin{matrix} +0.041 \\ +0.023 \end{matrix}$	10.5 ± 0.150	16 ± 0.100	2 ± 0.100	B-F7-27
7	$\begin{matrix} +0.015 \\ 0 \end{matrix}$	14	$\begin{matrix} 0 \\ -0.020 \end{matrix}$	5 ± 0.100	16 ± 0.100	1 ± 0.100	B-F7-6
8	$\begin{matrix} +0.036 \\ 0 \end{matrix}$	10	$\begin{matrix} -0.025 \\ -0.047 \end{matrix}$	3 ± 0.200	11.2 ± 0.200	0.6	B-F8-285
8	$\begin{matrix} +0.021 \\ +0.005 \end{matrix}$	10	$\begin{matrix} +0.038 \\ +0.023 \end{matrix}$	5 ± 0.100	13 ± 0.100	2 ± 0.200	B-F8-1
8	$\begin{matrix} +0.058 \\ 0 \end{matrix}$	10	$\begin{matrix} 0 \\ -0.036 \end{matrix}$	5.5 ± 0.300	12 ± 0.300	2 ± 0.100	B-F8-200
8	$\begin{matrix} +0.037 \\ +0.022 \end{matrix}$	10	$\begin{matrix} +0.100 \\ +0.082 \end{matrix}$	8 ± 0.200	12 ± 0.200	1.5 ± 0.200	B-F8-295
8	$\begin{matrix} +0.020 \\ 0 \end{matrix}$	10	$\begin{matrix} 0 \\ -0.020 \end{matrix}$	9.6 $\begin{matrix} 0 \\ -0.100 \end{matrix}$	$\begin{matrix} 12 \\ 11 \end{matrix}$ ± 0.100	$\begin{matrix} 5.5 \\ 0 \\ -0.100 \end{matrix}$	B-F8-158 ※
8	$\begin{matrix} +0.060 \\ +0.040 \end{matrix}$	10	$\begin{matrix} +0.038 \\ +0.023 \end{matrix}$	10 ± 0.300	14 ± 0.300	1 ± 0.100	B-F8-310
8	$\begin{matrix} +0.035 \\ +0.013 \end{matrix}$	11	$\begin{matrix} -0.016 \\ -0.043 \end{matrix}$	4.5 ± 0.100	13 ± 0.100	1.5 ± 0.100	B-F8-1078
8	$\begin{matrix} +0.020 \\ 0 \end{matrix}$	11	$\begin{matrix} +0.050 \\ +0.030 \end{matrix}$	7 ± 0.100	14 ± 0.100	2 ± 0.100	B-F8-3
8	$\begin{matrix} +0.060 \\ +0.040 \end{matrix}$	11	$\begin{matrix} +0.038 \\ +0.023 \end{matrix}$	7 ± 0.100	15.5 $\begin{matrix} -0.100 \\ -0.150 \end{matrix}$	2 ± 0.100	B-F8-4
8	$\begin{matrix} +0.030 \\ 0 \end{matrix}$	$\begin{matrix} 11 \\ 10 \end{matrix}$	$\begin{matrix} -0.010 \\ -0.050 \\ -0.050 \\ -0.100 \end{matrix}$	8 ± 0.200	14 ± 0.200	2 ± 0.200	B-F8-324 ※
8	$\begin{matrix} +0.047 \\ +0.025 \end{matrix}$	$\begin{matrix} 11 \\ 10.5 \end{matrix}$	$\begin{matrix} 0 \\ -0.027 \\ 0 \\ -0.100 \end{matrix}$	4 ± 0.100	13 ± 0.100	1.5 ± 0.100	B-F8-236 ※
8	$\begin{matrix} +0.015 \\ 0 \end{matrix}$	12	$\begin{matrix} +0.040 \\ +0.012 \end{matrix}$	3.5	20 ± 0.300	2 $\begin{matrix} 0 \\ -0.100 \end{matrix}$	B-F8-362
8	$\begin{matrix} +0.020 \\ +0.012 \end{matrix}$	12	$\begin{matrix} +0.015 \\ +0.005 \end{matrix}$	4 ± 0.100	16 ± 0.100	1.5 $\begin{matrix} 0 \\ -0.100 \end{matrix}$	B-F8-1019
8	$\begin{matrix} +0.022 \\ 0 \end{matrix}$	12	$\begin{matrix} +0.060 \\ +0.033 \end{matrix}$	4 ± 0.100	16 ± 0.100	1.5 ± 0.100	B-F8-8
8	$\begin{matrix} +0.015 \\ 0 \end{matrix}$	12	$\begin{matrix} +0.046 \\ +0.028 \end{matrix}$	4.5 ± 0.100	16 ± 0.100	2 ± 0.200	B-F8-100
8	$\begin{matrix} +0.049 \\ +0.013 \end{matrix}$	12	$\begin{matrix} +0.046 \\ +0.028 \end{matrix}$	5 ± 0.200	14 ± 0.200	2 ± 0.200	B-F8-199
8	$\begin{matrix} +0.050 \\ +0.020 \end{matrix}$	12	$\begin{matrix} 0 \\ -0.050 \end{matrix}$	5 ± 0.100	16 ± 0.150	2 ± 0.100	B-F8-13 ※
8	$\begin{matrix} +0.036 \\ 0 \end{matrix}$	12	$\begin{matrix} -0.032 \\ -0.075 \end{matrix}$	5 ± 0.300	16 ± 0.300	2 ± 0.300	B-F8-16
8	$\begin{matrix} +0.070 \\ +0.050 \end{matrix}$	12	$\begin{matrix} +0.040 \\ +0.020 \end{matrix}$	6 ± 0.100	14 ± 0.100	2 ± 0.200	B-F8-188
8	$\begin{matrix} +0.020 \\ 0 \end{matrix}$	12	$\begin{matrix} +0.050 \\ +0.030 \end{matrix}$	6 $\begin{matrix} 0 \\ -0.100 \end{matrix}$	16 ± 0.100	2 $\begin{matrix} 0 \\ -0.100 \end{matrix}$	B-F8-23
8	$\begin{matrix} +0.020 \\ 0 \end{matrix}$	12	$\begin{matrix} +0.050 \\ +0.030 \end{matrix}$	7 ± 0.100	14 ± 0.100	2 ± 0.100	B-F8-25
8	$\begin{matrix} +0.020 \\ 0 \end{matrix}$	12	$\begin{matrix} -0.005 \\ -0.025 \end{matrix}$	7 ± 0.150	$\begin{matrix} 14 \\ 13 \end{matrix}$ $\begin{matrix} \pm 0.150 \\ \pm 0.050 \end{matrix}$	2 ± 0.100	B-F8-26 ※
8	$\begin{matrix} +0.020 \\ 0 \end{matrix}$	12	$\begin{matrix} -0.005 \\ -0.025 \end{matrix}$	7 ± 0.150	$\begin{matrix} 14 \\ 13 \end{matrix}$ $\begin{matrix} +0.050 \\ -0.150 \\ \pm 0.050 \end{matrix}$	2 ± 0.100	B-F8-27 ※

d 8mm

Bore ϕd	Dimensions mm				Product code		
	Outer diameter ϕD	Length ℓ	Flange outer diameter ϕF	Flange thickness t			
8	$\begin{matrix} +0.015 \\ 0 \end{matrix}$	12	$\begin{matrix} +0.046 \\ +0.028 \end{matrix}$	7 ± 0.200	16 ± 0.100	1.5 ± 0.100	B-F8-29
8	$\begin{matrix} +0.175 \\ +0.155 \end{matrix}$	12	$\begin{matrix} +0.046 \\ +0.028 \end{matrix}$	8 ± 0.100	15 ± 0.100	2 ± 0.200	B-F8-30
8	$\begin{matrix} +0.015 \\ +0.003 \end{matrix}$	12	$\begin{matrix} +0.040 \\ +0.012 \end{matrix}$	8 $\begin{matrix} 0 \\ -0.100 \end{matrix}$	16 ± 0.150	2 $\begin{matrix} 0 \\ -0.100 \end{matrix}$	B-F8-1015
8	$\begin{matrix} +0.015 \\ 0 \end{matrix}$	12	$\begin{matrix} +0.040 \\ +0.012 \end{matrix}$	8 $\begin{matrix} 0 \\ -0.100 \end{matrix}$	16 ± 0.150	2 $\begin{matrix} 0 \\ -0.100 \end{matrix}$	B-F8-33
8	$\begin{matrix} +0.020 \\ +0.005 \end{matrix}$	12	$\begin{matrix} +0.040 \\ +0.012 \end{matrix}$	8 $\begin{matrix} 0 \\ -0.100 \end{matrix}$	16 ± 0.150	2 $\begin{matrix} 0 \\ -0.100 \end{matrix}$	B-F8-388
8	$\begin{matrix} +0.049 \\ +0.013 \end{matrix}$	12	$\begin{matrix} +0.075 \\ +0.032 \end{matrix}$	10 ± 0.300	14 ± 0.300	1 ± 0.100	B-F8-146
8	$\begin{matrix} +0.015 \\ 0 \end{matrix}$	12	$\begin{matrix} +0.046 \\ +0.028 \end{matrix}$	10 $\begin{matrix} 0 \\ -0.300 \end{matrix}$	15 ± 0.100	2 ± 0.100	B-F8-41
8	$\begin{matrix} +0.050 \\ +0.020 \end{matrix}$	12	$\begin{matrix} 0 \\ -0.050 \end{matrix}$	10 ± 0.150	16 ± 0.150	2 ± 0.100	B-F8-45 ※
8	$\begin{matrix} +0.040 \\ +0.020 \end{matrix}$	12	$\begin{matrix} 0 \\ -0.050 \end{matrix}$	10 ± 0.100	$\begin{matrix} 16 \\ 14 \end{matrix}$ $\begin{matrix} \pm 0.200 \\ \pm 0.200 \end{matrix}$	1.7 ± 0.100	B-F8-121 ※
8	$\begin{matrix} +0.050 \\ +0.020 \end{matrix}$	12	$\begin{matrix} 0 \\ -0.050 \end{matrix}$	12 $\begin{matrix} 0 \\ -0.300 \end{matrix}$	14 ± 0.100	1.5 $\begin{matrix} 0 \\ -0.100 \end{matrix}$	B-F8-50
8	$\begin{matrix} +0.015 \\ 0 \end{matrix}$	12	$\begin{matrix} +0.046 \\ +0.028 \end{matrix}$	12 ± 0.150	14 ± 0.100	2.5 ± 0.100	B-F8-52
8	$\begin{matrix} +0.055 \\ +0.040 \end{matrix}$	12	$\begin{matrix} +0.046 \\ +0.028 \end{matrix}$	12 ± 0.220	16 ± 0.140	2 ± 0.200	B-F8-103
8	$\begin{matrix} +0.036 \\ 0 \end{matrix}$	12	$\begin{matrix} -0.032 \\ -0.102 \end{matrix}$	15 ± 0.500	16 ± 0.300	2 ± 0.200	B-F8-58
8	$\begin{matrix} +0.022 \\ 0 \end{matrix}$	12	$\begin{matrix} +0.055 \\ +0.028 \end{matrix}$	16 ± 0.150	14 ± 0.100	2 ± 0.100	B-F8-59
8	$\begin{matrix} +0.061 \\ +0.025 \end{matrix}$	$\begin{matrix} 12 \\ 10 \end{matrix}$	$\begin{matrix} -0.032 \\ -0.075 \\ -0.040 \\ -0.200 \end{matrix}$	6.5 ± 0.100	14 ± 0.100	1 ± 0.100	B-F8-160 ※
8	$\begin{matrix} +0.030 \\ +0.010 \end{matrix}$	$\begin{matrix} 12 \\ 10 \end{matrix}$	$\begin{matrix} -0.010 \\ -0.030 \\ -0.050 \\ -0.100 \end{matrix}$	8 ± 0.100	16 ± 0.100	2 ± 0.100	B-F8-219 ※
8	$\begin{matrix} +0.035 \\ +0.013 \end{matrix}$	$\begin{matrix} 12 \\ 10 \end{matrix}$	$\begin{matrix} 0 \\ -0.060 \\ 0 \\ -0.100 \end{matrix}$	9.5	16 $\begin{matrix} 0 \\ -0.060 \end{matrix}$	4.5 ± 0.100	B-F8-212 ※
8	$\begin{matrix} +0.036 \\ 0 \end{matrix}$	$\begin{matrix} 12 \\ 10.8 \end{matrix}$	$\begin{matrix} -0.050 \\ -0.080 \\ 0 \\ -0.110 \end{matrix}$	4 ± 0.100	16 ± 0.140	2 ± 0.200	B-F8-1110K ※
8	$\begin{matrix} +0.036 \\ 0 \end{matrix}$	$\begin{matrix} 12 \\ 10.8 \end{matrix}$	$\begin{matrix} -0.032 \\ -0.102 \\ 0 \\ -0.110 \end{matrix}$	4 ± 0.200	16 ± 0.140	2 ± 0.200	B-F8-9 ※
8	$\begin{matrix} +0.036 \\ 0 \end{matrix}$	$\begin{matrix} 12 \\ 10.8 \end{matrix}$	$\begin{matrix} -0.032 \\ -0.102 \\ 0 \\ -0.070 \end{matrix}$	4.5 ± 0.200	16 ± 0.150	1 ± 0.150	B-F8-10 ※
8	$\begin{matrix} +0.036 \\ 0 \end{matrix}$	$\begin{matrix} 12 \\ 10.8 \end{matrix}$	$\begin{matrix} -0.032 \\ -0.102 \\ 0 \\ -0.110 \end{matrix}$	4.8 ± 0.200	16 ± 0.500	2 ± 0.200	B-F8-12 ※
8	$\begin{matrix} +0.022 \\ 0 \end{matrix}$	$\begin{matrix} 12 \\ 10.8 \end{matrix}$	$\begin{matrix} -0.032 \\ -0.102 \\ 0 \\ -0.110 \end{matrix}$	5 ± 0.200	16 ± 0.140	2 ± 0.200	B-F8-1086K ※
8	$\begin{matrix} +0.036 \\ 0 \end{matrix}$	$\begin{matrix} 12 \\ 10.8 \end{matrix}$	$\begin{matrix} -0.032 \\ -0.102 \\ 0 \\ -0.110 \end{matrix}$	5 ± 0.200	16 ± 0.140	2 ± 0.100	B-F8-346K ※

Note: Items indicated with an asterisk (*) have a special shape. Please contact NTN for details.
Please contact NTN with regard to the type of oil.
The material is copper based (H).

Flange Bearings

 d 8mm

Bore ϕd	Dimensions mm				Product code
	Outer diameter ϕD	Length l	Flange outer diameter ϕF	Flange thickness t	
8 $\begin{matrix} +0.036 \\ 0 \end{matrix}$	$\begin{matrix} 12 \\ \hline 10.8 \\ -0.110 \end{matrix}$ $\begin{matrix} -0.032 \\ -0.102 \\ 0 \end{matrix}$	5 ± 0.200	16 ± 0.140	2	B-F8-369K *
8 $\begin{matrix} +0.036 \\ 0 \end{matrix}$	$\begin{matrix} 12 \\ \hline 10.8 \\ -0.110 \end{matrix}$ $\begin{matrix} -0.032 \\ -0.102 \\ 0 \end{matrix}$	5 ± 0.200	$\begin{matrix} 16 \\ \hline 12 \\ \pm 0.200 \end{matrix}$ ± 0.140	2 ± 0.200	B-F8-195 *
8 $\begin{matrix} +0.022 \\ 0 \end{matrix}$	$\begin{matrix} 12 \\ \hline 10.8 \\ -0.110 \end{matrix}$ $\begin{matrix} -0.032 \\ -0.102 \\ 0 \end{matrix}$	6 ± 0.200	16 ± 0.140	2 ± 0.200	B-F8-112 *
8 $\begin{matrix} +0.036 \\ 0 \end{matrix}$	$\begin{matrix} 12 \\ \hline 10.8 \\ -0.110 \end{matrix}$ $\begin{matrix} -0.032 \\ -0.102 \\ 0 \end{matrix}$	8 ± 0.200	16 ± 0.140	2 ± 0.100	B-F8-101 *
8 $\begin{matrix} +0.036 \\ 0 \end{matrix}$	$\begin{matrix} 12 \\ \hline 10.8 \\ -0.110 \end{matrix}$ $\begin{matrix} -0.032 \\ -0.102 \\ 0 \end{matrix}$	12 ± 0.200	16 ± 0.200	2 ± 0.100	B-F8-116 *
8 $\begin{matrix} +0.036 \\ 0 \end{matrix}$	$\begin{matrix} 12 \\ \hline 10.8 \\ -0.110 \end{matrix}$ $\begin{matrix} -0.032 \\ -0.102 \\ 0 \end{matrix}$	14 ± 0.200	16 ± 0.140	2 ± 0.200	B-F8-56 *
8 $\begin{matrix} +0.050 \\ +0.020 \end{matrix}$	$\begin{matrix} 12 \\ \hline 11 \\ -0.050 \end{matrix}$ $\begin{matrix} -0.020 \\ -0.050 \\ 0 \end{matrix}$	7 ± 0.150	$\begin{matrix} 14 \\ \hline 13 \\ -0.050 \end{matrix}$ ± 0.100	2 ± 0.100	B-F8-245 *
8 $\begin{matrix} +0.036 \\ 0 \end{matrix}$	$\begin{matrix} 12 \\ \hline 11 \\ -0.100 \end{matrix}$ $\begin{matrix} 0 \\ -0.100 \\ 0 \end{matrix}$	10 ± 0.100	15 ± 0.100	2 ± 0.100	B-F8-152 *
8 $\begin{matrix} +0.025 \\ +0.005 \end{matrix}$	$\begin{matrix} 12 \\ \hline 11 \\ -0.100 \end{matrix}$ $\begin{matrix} -0.020 \\ -0.050 \\ 0 \end{matrix}$	$\begin{matrix} 21.4 \\ 0 \\ -0.200 \end{matrix}$	$\begin{matrix} 14 \\ \hline 13 \\ \pm 0.200 \end{matrix}$ ± 0.100	$\begin{matrix} 2.4 \\ 0 \\ -0.200 \end{matrix}$	B-F8-161 *
8 $\begin{matrix} +0.040 \\ +0.025 \end{matrix}$	$\begin{matrix} 12.5 \\ 0 \\ -0.100 \end{matrix}$	6 ± 0.100	19 ± 0.100	2 ± 0.100	B-F8-60
8 $\begin{matrix} +0.015 \\ 0 \end{matrix}$	$\begin{matrix} 12.5 \\ 0 \\ 0 \end{matrix}$ $\begin{matrix} +0.100 \\ 0 \end{matrix}$	12 ± 0.150	25 ± 0.150	3 $\begin{matrix} +0.100 \\ 0 \end{matrix}$	B-F8-62
8 $\begin{matrix} +0.022 \\ +0.010 \end{matrix}$	$\begin{matrix} 13 \\ +0.046 \\ +0.028 \end{matrix}$	5 ± 0.100	18 ± 0.100	$\begin{matrix} 2.8 \\ 0 \\ -0.100 \end{matrix}$	B-F8-296
8 $\begin{matrix} +0.017 \\ 0 \end{matrix}$	$\begin{matrix} 13 \\ +0.041 \\ +0.023 \end{matrix}$	6 ± 0.100	16 ± 0.150	2 ± 0.100	B-F8-221
8 $\begin{matrix} +0.015 \\ 0 \end{matrix}$	$\begin{matrix} 13 \\ 0 \\ -0.027 \end{matrix}$	10 ± 0.150	27 ± 0.150	3 ± 0.100	B-F8-66
8 $\begin{matrix} +0.035 \\ +0.013 \end{matrix}$	$\begin{matrix} 13 \\ +0.041 \\ +0.023 \end{matrix}$	11 ± 0.150	17 ± 0.100	2 ± 0.100	B-F8-67
8 $\begin{matrix} +0.050 \\ +0.030 \end{matrix}$	$\begin{matrix} 13 \\ +0.050 \\ +0.030 \end{matrix}$	12 ± 0.100	15 ± 0.100	3 ± 0.100	B-F8-68
8 $\begin{matrix} +0.017 \\ 0 \end{matrix}$	$\begin{matrix} 13 \\ +0.041 \\ +0.023 \end{matrix}$	12 ± 0.100	16 ± 0.150	2 ± 0.100	B-F8-69
8 $\begin{matrix} +0.050 \\ +0.010 \end{matrix}$	$\begin{matrix} 13 \\ -0.010 \\ -0.050 \\ \hline 10 \\ +0.100 \\ -0.050 \end{matrix}$	7 ± 0.150	16 ± 0.100	1.5 ± 0.100	B-F8-123 *
8 $\begin{matrix} +0.050 \\ +0.010 \end{matrix}$	$\begin{matrix} 13 \\ -0.010 \\ -0.050 \\ \hline 10 \\ +0.100 \\ -0.050 \end{matrix}$	9.5 ± 0.150	16 ± 0.100	1.5 ± 0.100	B-F8-65 *
8 $\begin{matrix} +0.030 \\ 0 \end{matrix}$	$\begin{matrix} 13 \\ -0.020 \\ -0.050 \\ \hline 11 \\ \pm 0.050 \\ -0.150 \end{matrix}$	8 ± 0.150	14 ± 0.100	2 ± 0.150	B-F8-270 *

 d 8~10mm

Bore ϕd	Dimensions mm				Product code
	Outer diameter ϕD	Length l	Flange outer diameter ϕF	Flange thickness t	
8 $\begin{matrix} +0.017 \\ 0 \end{matrix}$	$\begin{matrix} 13 \\ \hline 12 \\ -0.100 \end{matrix}$ $\begin{matrix} +0.041 \\ +0.023 \\ 0 \end{matrix}$	5 ± 0.100	16 ± 0.150	2 ± 0.100	B-F8-64 *
8 $\begin{matrix} +0.040 \\ 0 \end{matrix}$	$\begin{matrix} 13 \\ \hline 12 \\ -0.100 \end{matrix}$ $\begin{matrix} -0.020 \\ -0.040 \\ 0 \end{matrix}$	12 ± 0.200	$\begin{matrix} 16 \\ \hline 14 \end{matrix}$ ± 0.200	2 ± 0.100	B-F8-171 *
8 $\begin{matrix} +0.020 \\ 0 \end{matrix}$	$\begin{matrix} 14 \\ -0.032 \\ -0.075 \end{matrix}$	4 ± 0.300	15.6 ± 0.100	0.8 $\begin{matrix} 0 \\ -0.200 \end{matrix}$	B-F8-305
8 $\begin{matrix} +0.036 \\ 0 \end{matrix}$	$\begin{matrix} 14 \\ -0.032 \\ -0.075 \end{matrix}$	4 ± 0.150	18 ± 0.200	1 ± 0.300	B-F8-74
8 $\begin{matrix} +0.015 \\ 0 \end{matrix}$	$\begin{matrix} 14 \\ +0.046 \\ +0.028 \end{matrix}$	5.2 ± 0.100	17 ± 0.100	2 ± 0.100	B-F8-226
8 $\begin{matrix} +0.020 \\ 0 \end{matrix}$	$\begin{matrix} 14 \\ -0.005 \\ -0.025 \end{matrix}$	$\begin{matrix} 5.4 \\ 0 \\ -0.100 \end{matrix}$	$\begin{matrix} 16 \\ \hline 15 \\ \pm 0.050 \end{matrix}$ ± 0.150	2 ± 0.100	B-F8-1092K *
8 $\begin{matrix} +0.020 \\ 0 \end{matrix}$	$\begin{matrix} 14 \\ -0.005 \\ -0.025 \end{matrix}$	6 $\begin{matrix} 0 \\ -0.100 \end{matrix}$	$\begin{matrix} 16 \\ \hline 15 \\ \pm 0.050 \end{matrix}$ ± 0.150	2 ± 0.100	B-F8-78 *
8 $\begin{matrix} +0.020 \\ 0 \end{matrix}$	$\begin{matrix} 14 \\ 0 \\ -0.020 \end{matrix}$	10 ± 0.100	18 ± 0.100	2 ± 0.200	B-F8-153
8 $\begin{matrix} +0.020 \\ 0 \end{matrix}$	$\begin{matrix} 14 \\ 0 \\ -0.030 \\ \hline 12.5 \\ -0.100 \end{matrix}$	3.7 $\begin{matrix} 0 \\ -0.100 \end{matrix}$	16 $\begin{matrix} -0.100 \\ -0.300 \end{matrix}$	2 ± 0.080	B-F8-1038K *
8 $\begin{matrix} +0.020 \\ 0 \end{matrix}$	$\begin{matrix} 14 \\ 0 \\ -0.030 \\ \hline 12.5 \\ -0.100 \end{matrix}$	4 ± 0.100	16 $\begin{matrix} -0.100 \\ -0.300 \end{matrix}$	2 ± 0.080	B-F8-177 *
8 $\begin{matrix} +0.040 \\ +0.025 \end{matrix}$	$\begin{matrix} 14 \\ \hline 13.4 \\ -0.070 \end{matrix}$ $\begin{matrix} +0.046 \\ +0.028 \\ -0.020 \end{matrix}$	7 ± 0.100	16 ± 0.100	2 $\begin{matrix} 0 \\ -0.100 \end{matrix}$	B-F8-141 *
8 $\begin{matrix} +0.015 \\ 0 \end{matrix}$	$\begin{matrix} 15 \\ \hline 12 \\ -0.200 \end{matrix}$ $\begin{matrix} 0 \\ -0.018 \\ -0.050 \end{matrix}$	8 ± 0.100	20 ± 0.100	3 $\begin{matrix} 0 \\ -0.100 \end{matrix}$	B-F8-88 *
8 $\begin{matrix} +0.058 \\ 0 \end{matrix}$	$\begin{matrix} 16 \\ -0.010 \\ -0.050 \end{matrix}$	6 ± 0.100	18 $\begin{matrix} 0 \\ -0.200 \end{matrix}$	2 $\begin{matrix} 0 \\ -0.100 \end{matrix}$	B-F8-234
8 $\begin{matrix} +0.020 \\ 0 \end{matrix}$	$\begin{matrix} 16 \\ 0 \\ -0.030 \end{matrix}$	7 ± 0.100	20 ± 0.200	2 ± 0.100	B-F8-1016HB
8 $\begin{matrix} +0.028 \\ +0.005 \end{matrix}$	$\begin{matrix} 16 \\ +0.046 \\ +0.028 \end{matrix}$	17 ± 0.100	22 ± 0.100	2 ± 0.100	B-F8-169
9 $\begin{matrix} +0.040 \\ +0.020 \end{matrix}$	$\begin{matrix} 12 \\ +0.041 \\ +0.023 \end{matrix}$	8 ± 0.100	16 ± 0.200	2 $\begin{matrix} 0 \\ -0.100 \end{matrix}$	B-F9-1002
9 $\begin{matrix} +0.040 \\ +0.020 \end{matrix}$	$\begin{matrix} 12 \\ +0.026 \\ +0.006 \end{matrix}$	10.5 ± 0.100	14 ± 0.200	1.5 ± 0.100	B-F9-2
9 $\begin{matrix} +0.025 \\ 0 \end{matrix}$	$\begin{matrix} 17 \\ 0 \\ -0.025 \end{matrix}$	7 ± 0.100	20 ± 0.100	2 ± 0.200	B-F9-4
10 $\begin{matrix} +0.015 \\ 0 \end{matrix}$	$\begin{matrix} 13 \\ +0.046 \\ +0.028 \end{matrix}$	5.7 ± 0.100	14 ± 0.100	1 ± 0.100	B-F10-117
10 $\begin{matrix} +0.025 \\ +0.010 \end{matrix}$	$\begin{matrix} 13 \\ +0.040 \\ +0.020 \end{matrix}$	11 $\begin{matrix} 0 \\ -0.100 \end{matrix}$	14 $\begin{matrix} -0.100 \\ -0.200 \end{matrix}$	2.8 $\begin{matrix} 0 \\ -0.100 \end{matrix}$	B-F10-93
10 $\begin{matrix} +0.030 \\ +0.010 \end{matrix}$	$\begin{matrix} 13 \\ -0.032 \\ -0.075 \end{matrix}$	14 ± 0.150	16 ± 0.100	1.5 ± 0.100	B-F10-106
10 $\begin{matrix} +0.030 \\ +0.010 \end{matrix}$	$\begin{matrix} 13 \\ -0.032 \\ -0.075 \end{matrix}$	16 ± 0.100	$\begin{matrix} 16 \\ \hline 14.5 \\ \pm 0.200 \end{matrix}$ ± 0.100	1.5 ± 0.100	B-F10-107 *
10 $\begin{matrix} +0.036 \\ 0 \end{matrix}$	$\begin{matrix} 14 \\ 0 \\ -0.110 \end{matrix}$	4 ± 0.300	16 ± 0.400	2 ± 0.150	B-F10-3
10 $\begin{matrix} +0.015 \\ 0 \end{matrix}$	$\begin{matrix} 14 \\ +0.046 \\ +0.028 \end{matrix}$	5 ± 0.100	18 ± 0.100	2 ± 0.100	B-F10-7

Note: Items indicated with an asterisk (*) have a special shape. Please contact NTN for details.
Please contact NTN with regard to the type of oil.
The material is copper based (H).

Flange Bearings

d 10mm

Bore ϕd	Dimensions mm					Product code				
	Outer diameter ϕD	Length ℓ	Flange outer diameter ϕF	Flange thickness t						
10	$\begin{smallmatrix} +0.020 \\ +0.005 \end{smallmatrix}$	14	$\begin{smallmatrix} +0.046 \\ +0.028 \end{smallmatrix}$	5	± 0.100	19	± 0.150	2	± 0.100	B-F10-1048
10	$\begin{smallmatrix} +0.020 \\ +0.005 \end{smallmatrix}$	14	$\begin{smallmatrix} +0.046 \\ +0.028 \end{smallmatrix}$	5	± 0.100	19	± 0.150	2	± 0.100	B-F10-87
10	$\begin{smallmatrix} +0.015 \\ 0 \end{smallmatrix}$	14	$\begin{smallmatrix} +0.046 \\ +0.028 \end{smallmatrix}$	6	± 0.100	18	± 0.100	2	± 0.100	B-F10-72
10	$\begin{smallmatrix} +0.045 \\ +0.030 \end{smallmatrix}$	14	$\begin{smallmatrix} +0.050 \\ +0.032 \end{smallmatrix}$	6	± 0.100	18	± 0.200	2	± 0.100	B-F10-96
10	$\begin{smallmatrix} +0.050 \\ +0.020 \end{smallmatrix}$	14	$\begin{smallmatrix} 0 \\ -0.050 \end{smallmatrix}$	7	± 0.150	18	± 0.100	2	± 0.100	B-F10-10
10	$\begin{smallmatrix} +0.040 \\ +0.025 \end{smallmatrix}$	14	$\begin{smallmatrix} +0.046 \\ +0.028 \end{smallmatrix}$	7.5	± 0.150	18	± 0.100	2	± 0.100	B-F10-11
10	$\begin{smallmatrix} +0.015 \\ 0 \end{smallmatrix}$	14	$\begin{smallmatrix} +0.046 \\ +0.028 \end{smallmatrix}$	8	± 0.100	18	± 0.100	2	± 0.200	B-F10-113
10	$\begin{smallmatrix} +0.055 \\ +0.040 \end{smallmatrix}$	14	$\begin{smallmatrix} +0.046 \\ +0.028 \end{smallmatrix}$	8	± 0.100	18	± 0.100	2	± 0.100	B-F10-12
10	$\begin{smallmatrix} +0.015 \\ 0 \end{smallmatrix}$	14	$\begin{smallmatrix} +0.046 \\ +0.028 \end{smallmatrix}$	10	± 0.100	18	± 0.100	2	± 0.100	B-F10-15
10	$\begin{smallmatrix} +0.050 \\ +0.020 \end{smallmatrix}$	14	$\begin{smallmatrix} 0 \\ -0.050 \end{smallmatrix}$	10	$\begin{smallmatrix} 0 \\ -0.300 \end{smallmatrix}$	18	± 0.150	2	$\begin{smallmatrix} 0 \\ -0.100 \end{smallmatrix}$	B-F10-17 ※
10	$\begin{smallmatrix} +0.030 \\ +0.010 \end{smallmatrix}$	14	$\begin{smallmatrix} 0 \\ -0.050 \end{smallmatrix}$	10	$\begin{smallmatrix} 0 \\ -0.300 \end{smallmatrix}$	$\begin{smallmatrix} 18 \\ 16.5 \end{smallmatrix}$	$\begin{smallmatrix} \pm 0.200 \\ \pm 0.200 \end{smallmatrix}$	2	$\begin{smallmatrix} +0.100 \\ 0 \end{smallmatrix}$	B-F10-69 ※
10	$\begin{smallmatrix} +0.055 \\ +0.040 \end{smallmatrix}$	14	$\begin{smallmatrix} +0.046 \\ +0.028 \end{smallmatrix}$	12	± 0.220	18	± 0.140	2	± 0.200	B-F10-23
10	$\begin{smallmatrix} +0.015 \\ 0 \end{smallmatrix}$	14	$\begin{smallmatrix} +0.046 \\ +0.028 \end{smallmatrix}$	16	± 0.100	18	± 0.100	2	± 0.100	B-F10-26
10	$\begin{smallmatrix} +0.015 \\ 0 \end{smallmatrix}$	14	$\begin{smallmatrix} +0.046 \\ +0.028 \end{smallmatrix}$	18	± 0.200	18	± 0.100	2	± 0.100	B-F10-70
10	$\begin{smallmatrix} +0.036 \\ +0.016 \end{smallmatrix}$	$\begin{smallmatrix} 14 \\ 12 \end{smallmatrix}$	$\begin{smallmatrix} 0 \\ -0.043 \\ 0 \\ -0.200 \end{smallmatrix}$	7	± 0.200	$\begin{smallmatrix} 17 \\ 12 \end{smallmatrix}$	$\begin{smallmatrix} \pm 0.200 \\ 0 \\ -0.200 \end{smallmatrix}$	1.5	± 0.200	B-F10-9 ※
10	$\begin{smallmatrix} +0.036 \\ 0 \end{smallmatrix}$	$\begin{smallmatrix} 14 \\ 12.8 \end{smallmatrix}$	$\begin{smallmatrix} -0.032 \\ -0.102 \\ 0 \\ -0.110 \end{smallmatrix}$	4	± 0.200	18	± 0.140	2	± 0.200	B-F10-63 ※
10	$\begin{smallmatrix} +0.036 \\ 0 \end{smallmatrix}$	$\begin{smallmatrix} 14 \\ 12.8 \end{smallmatrix}$	$\begin{smallmatrix} -0.032 \\ -0.102 \\ 0 \\ -0.110 \end{smallmatrix}$	6	± 0.200	18	± 0.140	2	± 0.200	B-F10-131K ※
10	$\begin{smallmatrix} +0.036 \\ 0 \end{smallmatrix}$	$\begin{smallmatrix} 14 \\ 12.8 \end{smallmatrix}$	$\begin{smallmatrix} -0.032 \\ -0.102 \\ 0 \\ -0.110 \end{smallmatrix}$	8	± 0.200	18	± 0.140	2	± 0.200	B-F10-60 ※
10	$\begin{smallmatrix} +0.015 \\ 0 \end{smallmatrix}$	15	$\begin{smallmatrix} +0.046 \\ +0.028 \end{smallmatrix}$	6.5	± 0.100	18	± 0.100	2	± 0.100	B-F10-28
10	$\begin{smallmatrix} +0.035 \\ +0.013 \end{smallmatrix}$	15	$\begin{smallmatrix} +0.041 \\ +0.023 \end{smallmatrix}$	10	± 0.100	18	± 0.100	2	± 0.100	B-F10-30
10	$\begin{smallmatrix} +0.020 \\ 0 \end{smallmatrix}$	15	$\begin{smallmatrix} +0.050 \\ +0.030 \end{smallmatrix}$	13	± 0.100	18	± 0.100	2.5	± 0.100	B-F10-32
10	$\begin{smallmatrix} +0.035 \\ +0.013 \end{smallmatrix}$	15	$\begin{smallmatrix} +0.041 \\ +0.023 \end{smallmatrix}$	15	± 0.100	18	± 0.100	2	± 0.100	B-F10-80
10	$\begin{smallmatrix} +0.036 \\ 0 \end{smallmatrix}$	$\begin{smallmatrix} 15 \\ 14 \end{smallmatrix}$	$\begin{smallmatrix} -0.016 \\ -0.043 \\ 0 \\ -0.100 \end{smallmatrix}$	5.5	± 0.150	20	± 0.150	2.5	± 0.150	B-F10-67 ※
10	$\begin{smallmatrix} +0.035 \\ +0.013 \end{smallmatrix}$	$\begin{smallmatrix} 15 \\ 14 \end{smallmatrix}$	$\begin{smallmatrix} +0.041 \\ +0.023 \\ 0 \\ -0.100 \end{smallmatrix}$	6	$\begin{smallmatrix} 0 \\ -0.100 \end{smallmatrix}$	18	± 0.100	2	± 0.100	B-F10-1026K ※
10	$\begin{smallmatrix} +0.040 \\ +0.025 \end{smallmatrix}$	16	$\begin{smallmatrix} +0.041 \\ +0.023 \end{smallmatrix}$	6	± 0.100	22	± 0.100	3	± 0.100	B-F10-37
10	$\begin{smallmatrix} +0.040 \\ +0.020 \end{smallmatrix}$	16	$\begin{smallmatrix} 0 \\ -0.027 \end{smallmatrix}$	9	± 0.100	20	± 0.100	1.5	± 0.200	B-F10-38

d 10mm

Bore ϕd	Dimensions mm					Product code				
	Outer diameter ϕD	Length ℓ	Flange outer diameter ϕF	Flange thickness t						
10	$\begin{smallmatrix} +0.055 \\ +0.040 \end{smallmatrix}$	16	$\begin{smallmatrix} +0.046 \\ +0.028 \end{smallmatrix}$	10	± 0.180	22	± 0.170	3	± 0.200	B-F10-54
10	$\begin{smallmatrix} +0.020 \\ +0.005 \end{smallmatrix}$	16	$\begin{smallmatrix} +0.025 \\ +0.005 \end{smallmatrix}$	12	$\begin{smallmatrix} +0.300 \\ -0.100 \end{smallmatrix}$	19	± 0.150	2	$\begin{smallmatrix} +0.100 \\ -0.200 \end{smallmatrix}$	B-F10-40
10	$\begin{smallmatrix} +0.090 \\ +0.070 \end{smallmatrix}$	16	$\begin{smallmatrix} +0.040 \\ 0 \end{smallmatrix}$	12	± 0.100	19	$\begin{smallmatrix} +0.040 \\ 0 \end{smallmatrix}$	2	± 0.100	B-F10-41
10	$\begin{smallmatrix} +0.023 \\ +0.015 \end{smallmatrix}$	16	$\begin{smallmatrix} +0.036 \\ +0.018 \end{smallmatrix}$	15	± 0.100	19	± 0.200	5	± 0.100	B-F10-73
10	$\begin{smallmatrix} +0.040 \\ +0.025 \end{smallmatrix}$	16	$\begin{smallmatrix} +0.041 \\ +0.023 \end{smallmatrix}$	16	± 0.100	22	± 0.100	3	± 0.100	B-F10-42
10	$\begin{smallmatrix} +0.015 \\ 0 \end{smallmatrix}$	16	$\begin{smallmatrix} +0.046 \\ +0.028 \end{smallmatrix}$	16	± 0.150	22	± 0.200	3	± 0.100	B-F10-65
10	$\begin{smallmatrix} +0.040 \\ +0.025 \end{smallmatrix}$	16	$\begin{smallmatrix} +0.041 \\ +0.023 \end{smallmatrix}$	17	± 0.150	22	± 0.150	3	± 0.100	B-F10-44
10	$\begin{smallmatrix} +0.015 \\ 0 \end{smallmatrix}$	16	$\begin{smallmatrix} +0.046 \\ +0.028 \end{smallmatrix}$	20	± 0.150	22	± 0.150	3	± 0.100	B-F10-45
10	$\begin{smallmatrix} +0.070 \\ +0.050 \end{smallmatrix}$	$\begin{smallmatrix} 16 \\ 15 \end{smallmatrix}$	$\begin{smallmatrix} +0.025 \\ +0.005 \\ 0 \\ -0.150 \end{smallmatrix}$	6	± 0.200	19	± 0.100	2	± 0.100	B-F10-36 ※
10	$\begin{smallmatrix} +0.040 \\ +0.020 \end{smallmatrix}$	$\begin{smallmatrix} 18 \\ 16 \end{smallmatrix}$	$\begin{smallmatrix} 0 \\ -0.020 \\ 0 \\ -0.100 \end{smallmatrix}$	5	± 0.100	22	± 0.300	1.5	± 0.050	B-F10-103 ※
10	$\begin{smallmatrix} +0.020 \\ +0.005 \end{smallmatrix}$	$\begin{smallmatrix} 22 \\ 20.5 \end{smallmatrix}$	$\begin{smallmatrix} -0.030 \\ -0.055 \\ 0 \\ -0.100 \end{smallmatrix}$	11.6	± 0.100	26	± 0.100	2	± 0.100	B-F10-111 ※

Note: Items indicated with an asterisk (*) have a special shape. Please contact NTN for details.
Please contact NTN with regard to the type of oil.
The material is copper based (H).



IV Torque Limiters

1. Torque Limiter Units (NTS Type)47
2. Torque Limiter Units (NTB 14 Type)49

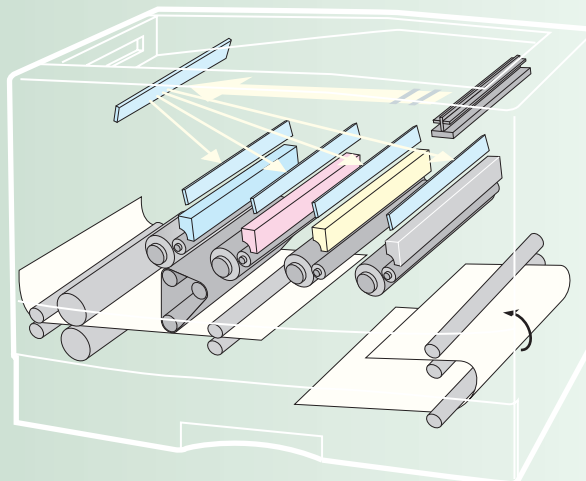

1. Torque Limiter Units (NTS Type)



1.1 Structure and torque generating mechanism

The NTN torque limiter unit (NTS type) is made up of an inner ring, coil spring, external resin part and lid.

When the torque that acts between the inner ring and external resin parts is small, the inner ring and external part move together. When the torque increases, the mechanism is designed to rotate relatively while maintaining a certain level of torque.

The principle behind the generating of the torque is the use of the tensioning force that the coil spring applies to the inner ring. The tensioning force controls the rotational torque in the direction of the generated torque.

As the internal construction in **Figure 1** shows, there is a difference in diameter in the coil spring. The small diameter section is connected to the torque generating section and the larger diameter section is connected to the torque adjustment section.

The torque is set when the lid rotates relative to the external resin part and the large diameter section is twisted. The force of the twisting reduces the diameter of the small diameter section, so that tensioning force is applied to the inner ring.

Therefore, even if the contact state of the small diameter section spring inner diameter and inner ring external diameter changes, the twisting force stored in the large diameter section automatically corrects this, so that stable torque is generated for a long period.

Note that this NTN torque limiter unit (NTS type) cannot be used in the reverse direction of the direction the torque is generated.

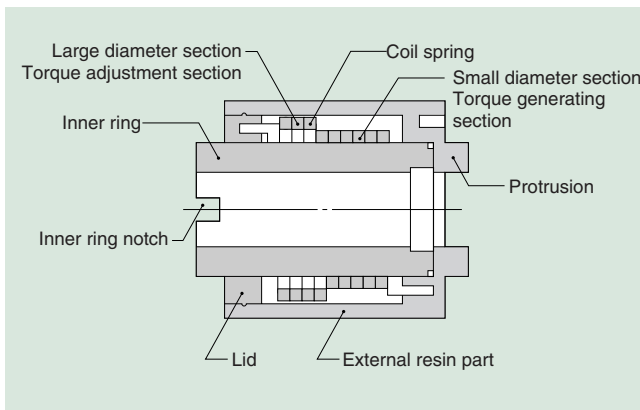

Fig. 1 Internal construction

Table 1 Component Parts and Materials

Component parts	Materials	
	NTS16B	NTS18D
External resin part	POM	
Lid	POM	
Coil spring	Spring steel	
Inner ring	Sintered iron	
Lubricant	Chemical attack preventing oil (Impregnated in the inner ring)	

1.2 Standard Shape

The standard shape of the NTN torque limiter unit (NTS type) is shown in **Figure 2**. **Table 2** shows the dimensions of the various sections and the torque settings. Please contact NTN for inquiries about shapes other than the standard shapes.

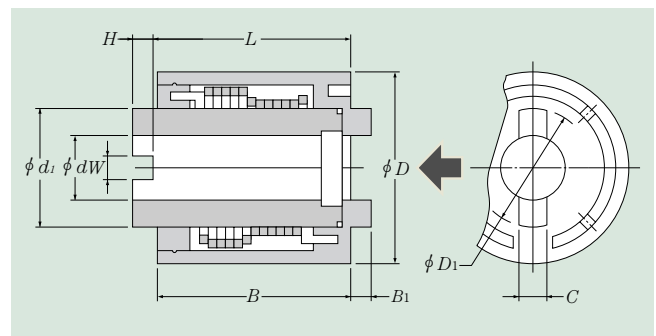

Fig. 2 Standard Shape

Table 2 Dimensions and Torque Settings

Model code	NTN standard shape dimensions mm										Torque settings mN·m {gf·cm}
	D	B	d	d1	B1	C	D1	W	H	L	
NTS16B	16	18	6	9	1.9	2.9	11	2.1	2	18.3	9.8~19.6 {100~200}
NTS18D	18	18	6	11	1.9	2.9	11	2.1	2.5	18.3	19.6~49.0 {200~500}

- 1) The torque setting may be limited by the operating conditions (rotational speed, temperature, etc.).
- 2) The minimum dimensions of the external resin part are *D* and *B* in **Table 2**. We can also handle dimensions other than these.
- 3) Rotational direction and identification

The NTN torque limiter unit (NTS type) only generates torque in one direction. The direction of the rotation can be identified by the color of the external resin part on the torque limiter.

Table 3 indicates the direction of the rotation and the identification method (color).

When ordering this part, be sure to add R or L to the product code.

Table 3 Identifying the Rotational Direction (Example: NTS18DR)

Product code	Rotational direction [※]	Identification method (color)
NTS16B or NTS18D	Clockwise rotation (R type)	External resin part: Black Lid: Black
	Counterclockwise rotation (L type)	External resin part: Grey Lid: Grey

[※]The direction of rotation is determined in the following way: Viewing the unit from the direction of the arrow in **Figure 2**, with the inner ring is fixed, turning the external resin part clockwise (right rotation) is the R type, and turning it counterclockwise (left rotation) is the L type.

- 4) See **Figure 3** for the usable range of the NTN torque limiter unit (NTS type). Please contact NTN for inquiries about using this product outside its usable range.

1.3 Guidelines for usable ranges

Based on the results of operation tests conducted using the NTN durability testing machine, the usable range of the NTN torque limiter unit (NTS type) is as indicated in Figure 3. In addition, Figure 4 shows a typical example of durability test results.

Please consider these usable ranges as guidelines only. Please contact NTN for inquiries about using this product outside its usable range.

(Test conditions and judgment conditions)

- Operating cycle: 2 seconds ON, 0.2 seconds OFF
- Operating time: 1000 hours
- Judgment method: Judged when the generated torque is within $\pm 15\%$ of the initial setting value.

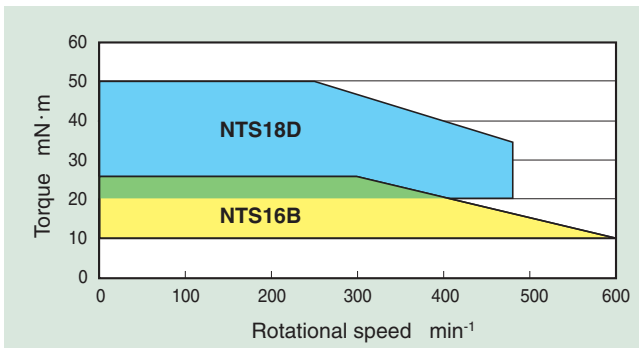

Fig. 3 Guidelines for the Usable Range

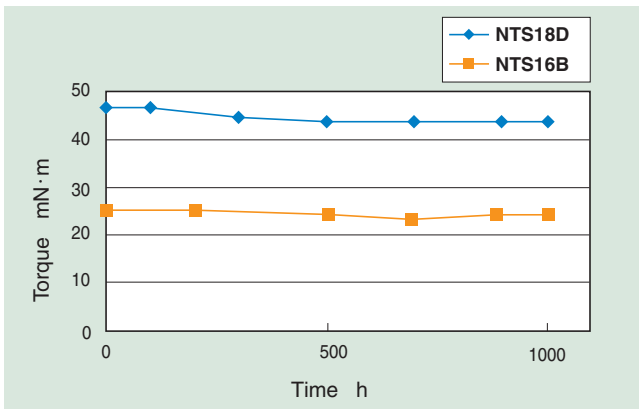

Fig. 4 Typical Example of Durability Test Results

1.4 Usage precautions

1) Rotational direction (Cannot be rotated in the locking direction)

The torque generating spring is connected to the external resin part with a hook. If the unit is rotated in the locking direction, the spring may be damaged. (Fig. 5)

2) Installation

If a radial load is applied from the outside, there may be a fluctuation in torque. Therefore, we recommend studying the method in Figure 6 when installing the torque limiter. When inserting a shaft into the torque limiter from the direction of the arrow in Figure 7, inserting the shaft at an angle may push the inner ring out.

3) Other precautions

- Do not pull the inner ring out in the axial direction.
- Do not drop the torque limiter or subject to other impact.
- The NTN torque limiter unit (NTS type) has an inner ring impregnated with lubricant. Therefore, do not let the inner ring of the torque limiter come into contact with paper, cloth or other material.

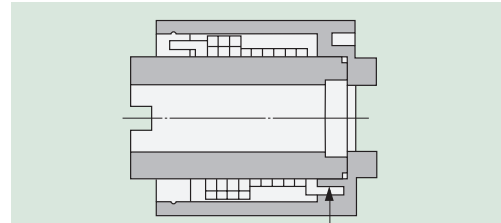

Rotating the NTS 18D in the direction opposite of the generated torque will cause locking tension to be concentrated on the hook section of the coil spring, leading to damage.

Fig. 5 Coil Spring Damage Caused by Rotating the Wrong Way

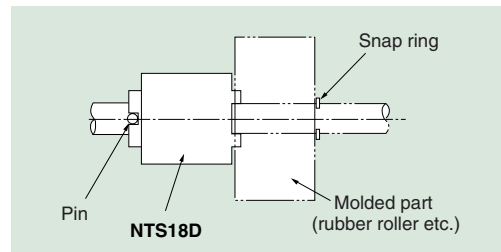

Fig. 6 Installation Example

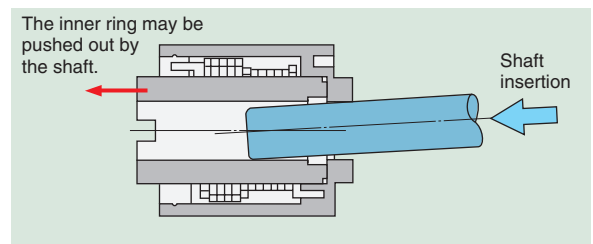

Fig. 7 Shaft Installation

1.5 Necessary conditions in manufacturing

Table 4 shows the necessary items for manufacturing the NTN torque limiter unit (NTS type).

Table 4 Necessary Items for Manufacturing

Necessary items	Description
Shape	Possible to use with the standard NTN shape. If a shape other than the standard shape is required, be sure to submit the desired shape. Be sure to inform us of the required torque and torque tolerance.
Torque setting and tolerance	The torque tolerance is $\pm 15\%$ of the standard torque requirement. Please contact NTN and inquire about values lower than this.
Torque generating direction	Be sure to indicate the R or L type.
Rotational speed	Please inform us of the rotational speed during torque limiter operation (when slipping occurs). The torque setting is determined by the rotational speed to be used. However, for rotational speeds under 50 min^{-1} , the torque setting will always be set for 50 min^{-1} .
Operating cycle	Please inform us of the operating cycle (ON time, OFF time).
Service life	Please inform us of the required service life. In general, the service life is 1,000 hours (2 seconds ON, 0.2 second OFF).
Operating temperature	Please inform us of the ambient operating temperature. The operating temperature guidelines for the NTS type is -10°C to 50°C . Please contact NTN and inquire if outside the temperature range (guidelines).

2. Torque Limiter Units (NTB 14 Type)



Structural product dimensions of $\phi 14 \times 12$ have been achieved. (External resin part)
This will help to reduce the space usage in devices.

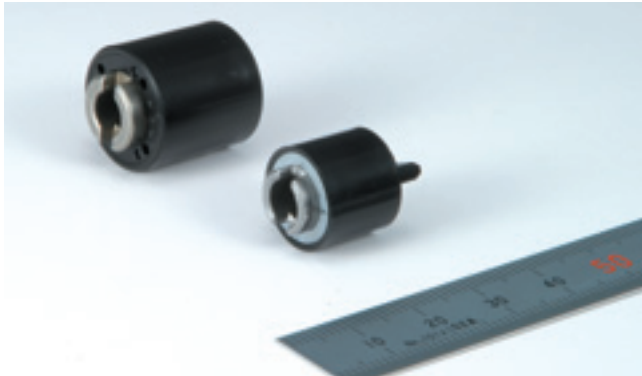

Comparison of the NTS 18D and NTB 14
(Left: NTS 18D; Right: NTB 14 Type)

2.1 Features

1) Small (NTS 18 type: $\phi 18 \times 18$ mm \rightarrow NTB 14 type: $\phi 14 \times 12$ mm)

The external diameter and length of the external resin part are smaller than those of the NTN torque limiter unit (NTS type). By making this unit smaller, it can now be used as part of paper feeding rubber rollers.

2) Bidirectional rotation

A new design allows rotation in both directions. This will simplify removal of paper when there are paper jams.

2.2 Durability

A typical example of durability test results is shown in **Figure 1**.

We have confirmed that the performance is equivalent to conventional units. (At 300 hours)

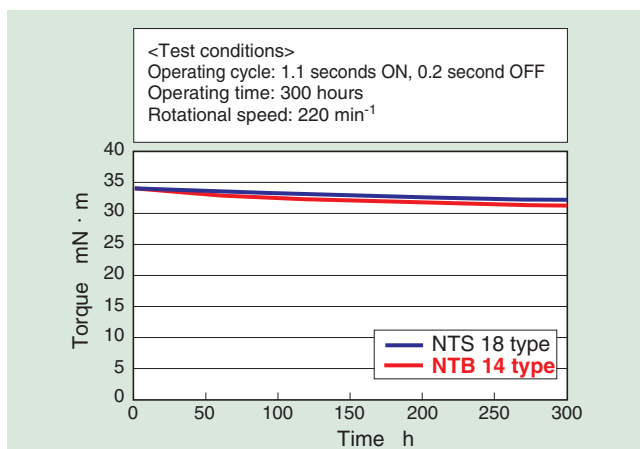

Fig. 1 Typical Example of Durability Test Results

2.3 Standard shape

Figure 2 shows the standard shape of the NTN torque limiter unit (NTB 14 type). NTN can also make non-standard shapes.

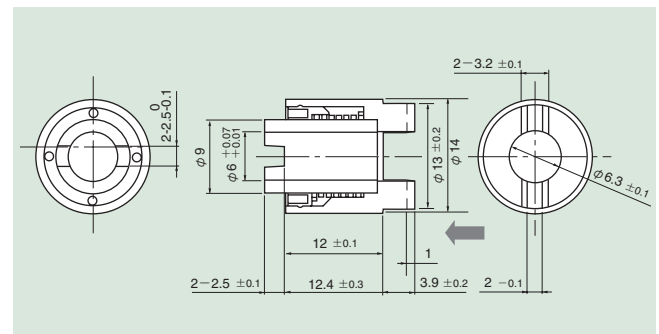

Fig. 2 Standard Shape of the NTB 14 Type

- 1) Product code of the standard shape: NTB14-1
- 2) Torque setting: 24.5–39.2 mN·m {250–400 gf·cm}
- 3) **Table 1** shows the component parts and materials.

Table 1 Component Parts and Materials

Component parts	Materials used
	NTB14
External resin part	POM (color: black)
Lid	POM (color: white)
Coil spring	Spring steel
Inner ring	Sintered iron
Lubricant	Chemical attack preventing oil (Impregnated in the inner ring)

- 4) The direction of rotation is determined in the following way: Viewing the unit from the direction of the arrow in **Figure 2**, with the inner ring being fixed, turning the external resin part clockwise (right rotation) is the R type, and turning it counter-clockwise (left rotation) is the L type. When ordering this part, be sure to add R or L to the product code.

Example: NTB14-1R

2.4 Handling of Torque Limiter Unit

- 1) The inner ring must remain assembled with the unit at all times.
- 2) The Torque Limiter Unit is not able to accept shock loads or drop impacts.
- 3) The inner ring of NTB 14 type is impregnated with lubricant. Therefore, the inner ring should not be allowed to contact paper, cloth, or other material that may wick the lubricant away.



V Clutches

- 1. NTN One-way Clutch 51
- 2. One-way Clutch Unit Specifications 55
- 3. Technical Data 55
- 4. One-way Clutch 56
- 5. One-way Clutch Units 60
- 6. Torque Diodes 62
- 7. Introduction to Products Being Developed 64

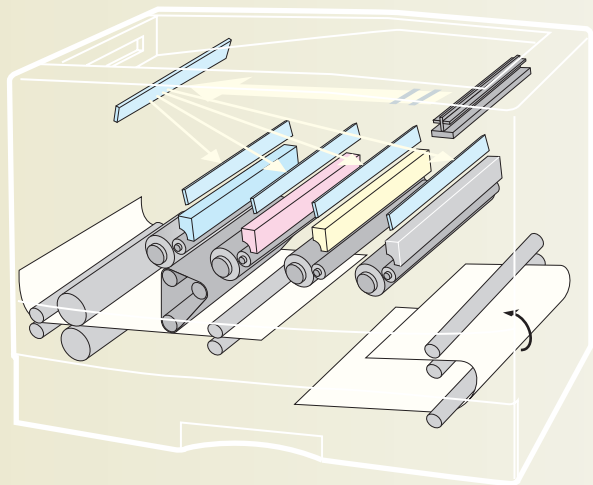

1. NTN One-way Clutch



1.1 Features of the one-way clutch

The one-way clutch only drives in one direction and is idle in the other direction. The drive and idle directions can be switched.

NTN has a wide variety of one-way clutches to meet various needs.

● Stable idle rotation

Because the force of the spring that holds the roller is adjusted accurately, roller movement is slight when idle, so that the idle torque is stable.

Please contact NTN if the required idle rotation is fast.

● Cross section height is small and the unit is compact

The HF and HFL types have thin external rings made of steel plate that has been made by precision extrusion. This has allowed these shell type one-way clutches to have a low cross section height and compact design.

● Simple handling

The one-way clutch series has the clutches press fit tightly into the housing inner diameter, so that there is no need for a fixing device in the axial direction. In addition, torque can be transmitted with this fit alone, thus making handling simple.

● No need for a radial load bearing (excluding the HF type)

Because radial load bearings are built into both sides of the clutch unit (HFL type: needle roller with cage; NHF type: oil-impregnated bearing), external radial load bearings are not needed.

● Excellent clutch accuracy

Each roller is precisely supported by a spring and they are fabricated with high precision so that they always engage together, thereby achieving excellent clutch accuracy. The delay angle that exists until rotational torque is completely transmitted includes both the sliding angle and the displacement angle that is created by the elastic deformation of the contact section between the rollers, shaft and external ring. This value will differ depending on the size of the clutch and load torque, but the average value of the delay angle up to the torque capacity (listed in the Dimensions Table) is 3 degrees or less. (Based on NTN measurements.)



HF type



HFL type



NHF type

1.2 Features of the one-way clutch unit

● Compact design possible by using units

This product is comprised of a unit that includes external parts and the one-way clutch. The NCZC type and NCUX type have an even smaller width and allow effective use of space, so that the overall design can be made even more compact.

● Resin external parts that can be made to the designated shape

The gears, pulleys, rubber roller receptacles and other external parts are made of resin, and can be made in various shapes and dimensions per your requirements.

● High degree of freedom concerning the selection of shafts used

The clutch functions satisfactorily even if the shaft tolerance is large. In addition, shafts can be made from a wide variety of steels. (However, if a soft material is used, the torque capacity will decrease.)

● Can be used at high temperatures

The NCZ type does not use any resin parts in the clutch interior. Therefore, it can be used in high temperature conditions (140°C or less). (However, please consult with NTN if the part is to be used at 100°C or more.)



NCU type



NCZ type

Delay angle

The delay angle refers to the difference ($\theta_t - \theta_o$) between the input shaft rotational angle (θ_t) and output shaft rotational angle (θ_o). The delay angles of NTN one-way clutch units differ depending on the type and the torque that is applied to the one-way clutches. The figure below shows the general trend. (Based on NTN measurements.)

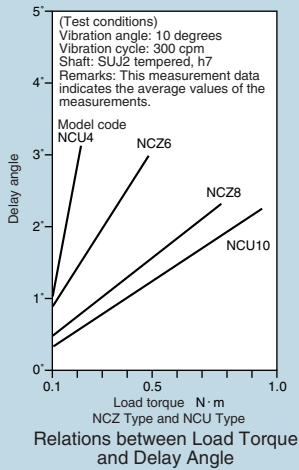

Service life

Even when torque is applied up to the torque capacity in NTN one-way clutch units and the units are engaged over one million times, we have confirmed that there is little change in the delay angle. (Based on NTN measurements.)

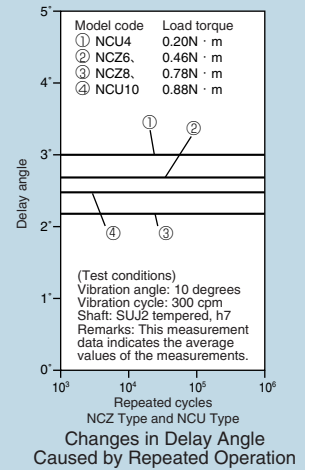

1.3 Operating mechanism

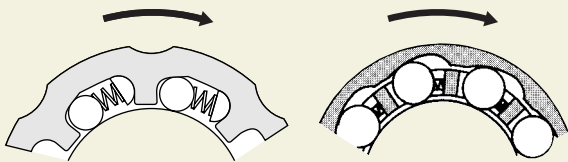

Clutch engaged

When the outer ring tries to turn clockwise with respect to the shaft, the spring is activated and the rollers advance to the engagement position of the outer ring cam surface, then the wedge action between the outer ring cam surface and shaft drives the shaft.

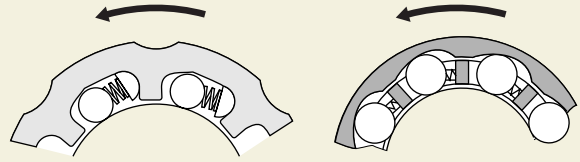

Clutch idle

When the outer ring turns counterclockwise with respect to the shaft, the shaft turns clockwise with respect to the outer ring, so that the rollers are released from the outer ring cam surface and the outer ring is disengaged from the shaft.

1.4 Types and construction

NTN one-way clutches

One-way clutches

One-way clutch units

HF type Partially INA products	HFL type Partially INA products	NHF type	NCU type	NCZ type	NCZC type	NCZX type NCUX type
The clutch unit is made up of a needle roller, cage and spring. The outer ring is a shell shape that is made by precision extrusion of thin steel plate. As a radial load, use NTN BEARPHITE oil-impregnated bearings or shell shaped needle roller bearings.	The HF type has needle rollers with cages built into both sides for radial loads.	The clutch unit is made up of a needle roller, cage and spring. The outer ring is a solid unit with NTN BEARPHITE oil-impregnated bearings built into both sides for radial loads.	The main unit is made up of an outer ring, lid, roller, cage and spring. The outside has resin external parts including a gear, pulley and roller receptacle to make up the unit.	The main unit is made up of an outer ring with cage, lid, roller and steel single piece ring spring. The outside has resin external parts including a gear, pulley and roller receptacle to make up the unit.	The outer diameter dimension has been made as small as possible to reduce the amount of space needed in the outer diameter direction. The outside has resin external parts including a gear, pulley and roller receptacle to make up the unit.	The width has been made as small as possible in order to cope with the need for smaller units. The outside has resin external parts including a gear, pulley and roller receptacle to make up the unit.

1.5 Selection guidelines

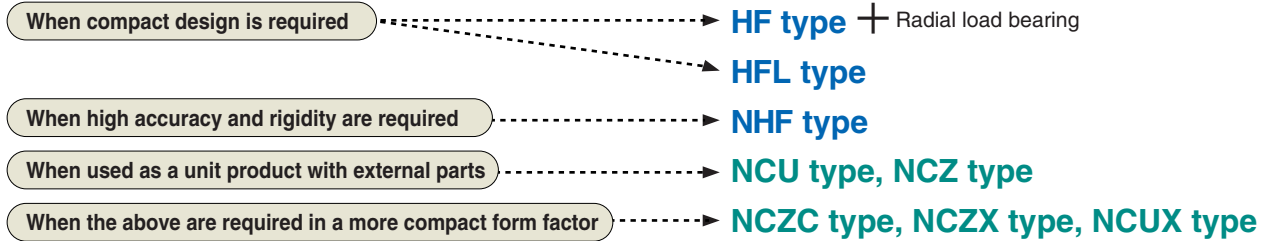

Lubrication

Oil lubrication is best for these one-way clutches, but, in general, grease lubrication is usually used. NTN one-way clutches are filled with suitable grease, so that they can be installed immediately. In general use there is no need to resupply grease; however, if grease is resupplied, note that too much grease can interfere with clutch operation. Please consult with NTN for the type of lubricant to use.

Allowable operating temperature

HF type, HFL type ····	Oil lubricant	: -10~120°C
	Grease lubricant	: -10~ 70°C
NHF type ·······························		-10~100°C
NCU type, NCUX type ···················		-10~100°C
NCZ type, NCZC type, NCZX type ·······		-10~140°C

Please consult with NTN when using these units outside their allowable operating temperatures or when using the NCZ type at over 100°C.

Engagement direction

● HF type, HFL type, NHF type

The NHF type has an arrow (→) on the outer diameter surface or oil-impregnated bearing edge, and the HF type and HFL type have arrows on the outer ring sides. Turning the outer ring in the direction of the arrow will engage the clutch.

● NCU type, NCZ type, NCZC type, NCZX type, NCUX type

Turning the external resin part in the direction of the arrow (→) on the side of the external resin part will engage the clutch.

Selection precautions

NTN checks the functions of its one-way clutches under many different test conditions. However, the service life may be reduced if they are used with heavy load torques, high oscillation cycles or minute oscillations, if the shaft is not hard, and if a large radial load acts on the one-way clutch unit. In addition, if the idling rotational speed is high or the clutch is used often in idle, there is a possibility that lock problems might occur.

Please consult with NTN when using these units under these special conditions.

Shaft and housing (HF type, HFL type, NHF type) /external resin parts (NCU type, NCZ type, NCZC type, NCZX type, NCUX type) specifications

Type	One-way clutch			One-way clutch unit			
	HF type	HFL type	NHF type	NCU type	NCZ type, NCZC type	NCZX type, NCUX type	
Shaft	Material	Tempered steel, case hardened steel (Hardness HRC58-64; effective depth 0.4 mm or greater for carburizing)		Carbon steel, stainless steel, tempered steel, case hardened steel (Surface hardness if tempered: HRC50 or greater)			
	Dimensions Tolerance	h5(h6)		NCU4 ···h9 NCU10···h10	NCZ6, 8 } NCZC6, 8 } ···h9	NCZX6, 8···h9 NCUX4····h8	
	Cylindricity	One-half of tolerance		One-half of tolerance			
	Roughness	0.2a (Ra)		0.3~1.6a (Ra)			
Housing (HF type, HFL type, NHF type) External resin part (NCU type, NCUX type, NCZ type, NCZC type, NCZX type)	Material	Steel, cast iron, light metal alloys			Standard: Polyacetal resin (They can also be made of oil-impregnated polyacetal resin and PBT resin.)		
	Bore Tolerance	Steel, cast iron: N6 (N7) Light metal alloy: R6 (R7)			————		
	Cylindricity	One-half of tolerance		One-half of tolerance			
	Roughness	1.6a		1.6a			
	Wall- thickness	Steel, cast iron: 0.75 ($D-F_w$) or greater Light metal alloy: 1.5 ($D-F_w$) or greater (See the dimensions table for the $D-F_w$ dimension)			————		
Remarks	————			Gear accuracy: Grade 6 is the standard for JGMA engagement accuracy.			

Remark 1) Round off the tip of the shaft to facilitate insertion into the one-way clutch. (Minimum 0.3 mm)

1.6 Installation precautions

Use of a press-fitting mandrel as shown in the figure is convenient for installing a one-way clutch. **When installing an HF type or HFL type, be sure that the side with the mark comes into contact with the mandrel when press fitting. In addition, when installing the NHF type, be sure to press fit the outer ring and use a jig to avoid pressing the oil-impregnated bearing section.**

Precautions for assembly include not twisting the outer ring, not directly striking the outer ring with a hammer, and using an appropriate jig on the outer ring side when press fitting.

When assembling in a press for mass production, using a mandrel with an O-ring as shown in the figure will prevent the one-way clutch from falling off and facilitate insertion.

The dimensions of the mandrel are shown below.

$$A = D - (0.2 \text{ to } 0.3) \text{ mm (in the case of NHF, } A \text{ is greater than } D)$$

$$B = d \text{ or } F_w - (0 \text{ to } 0.025) \text{ mm}$$

D : Outer diameter of the one-way clutch, mm

d : Bore of the oil-impregnated bearing, mm

F_w : Inscribed circle diameter of the roller, mm

(See the dimensions table)

Shaft assembly can be facilitated by turning the shaft in the direction that the clutch is disengaged.

If the shaft cannot be turned during installation, installation can be facilitated by attaching a tapered guide (chamfered) to the end of the shaft.

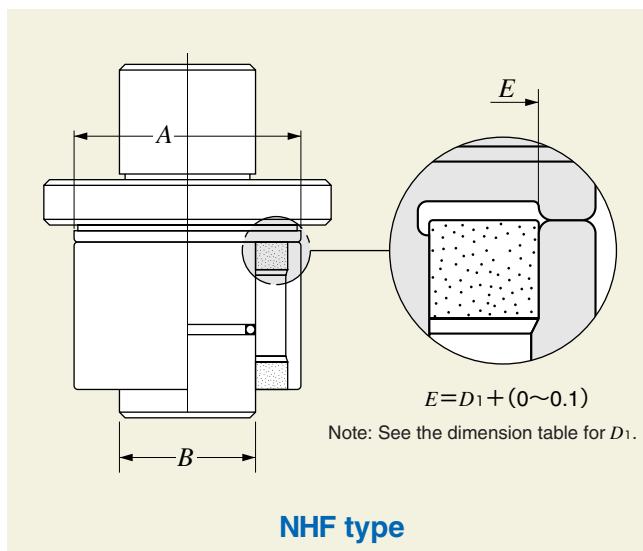
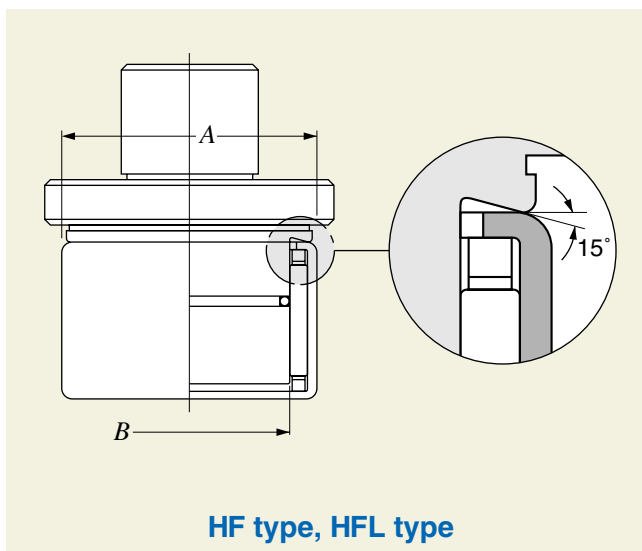

When installing or removing the one-way clutch or one-way clutch unit, turn the gear in the direction of the arrow in the figure (idle direction) to prevent damaging the shaft.

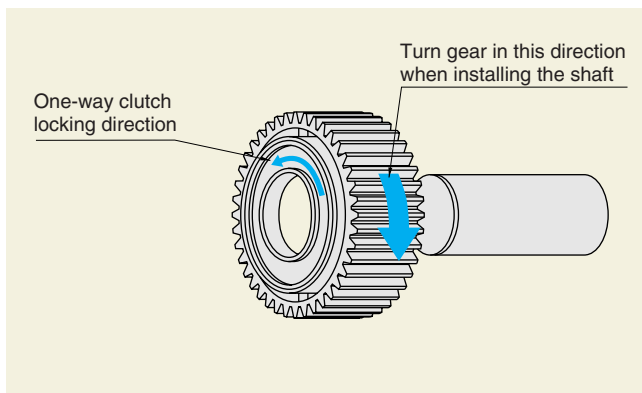

1.7 Handling of One Way Clutch

The One Way Clutch is not able to accept shock loads or drop impacts.

2. One-way Clutch Unit Specifications

2.1 Name codes

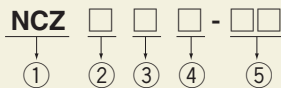

- ① Type code: NCZ type, NCZX type, NCZC type, NCU type, NCUX type
- ② Shaft diameter
- ③ Lubrication code: See the table below

Lubrication code	Type of lubricant	Operating temperature guidelines
None	Standard grease (sealed)	~100°C
D	Chemical attack preventing lubricating oil (oil-impregnated)	~100°C
A	High temperature grease or lubricant oil (oil-impregnated)	100~140°C

- ④ Resin part shape codes: C: cam; G: gear; P: pulley; R: roller; Z: other
- ⑤ Additional numbers

* Only standard grease is used for lubricating NCU type and NCUX type.

2.2 Resin materials used

The resin materials that have been used are listed.

Operating temperature guidelines	Resin material	Grade (UL fire resistant)	
		General purpose	M90-44, M90S (UL94HB)
~100°C	POM (Duracon) Polyplastics	Easy sliding	NW-02 (UL94HB)
		General purpose	LA543 (UL94HB)
100°C~	PPS (Fortron) Polyplastics	Unfilled	0220A9 (UL94VO) ...Reference

- 1) We can also use any other designated material, so please consult with NTN.
- 2) We will provide the resin part shapes that are designated.
- 3) If the lid must not be easily removable and requires rotational strength, it is sometimes impossible to achieve this because of operating temperatures, the resin materials used, and wall thickness, so please consult with NTN.

3. Technical Data

3.1 Durability test results for various shaft materials

The shafts used for office equipment are usually non-tempered shafts. The durability test results for non-tempered shafts are shown.

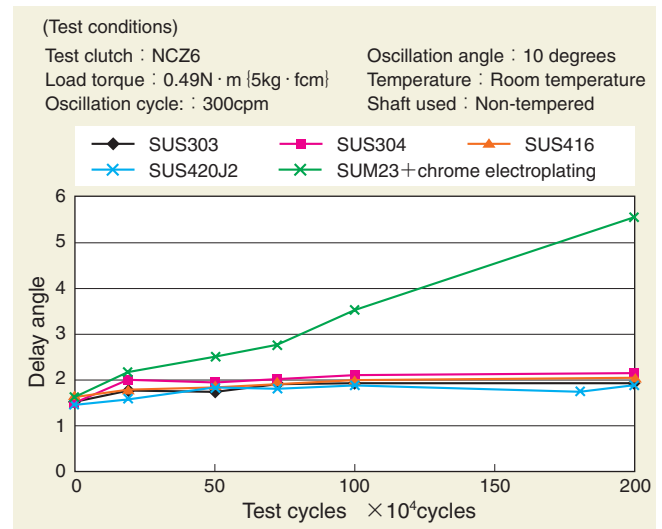

If the shaft is made from stainless steel (SUS), we have confirmed durability for over a million cycles even if non-tempered. Conversely, SUM + electroplating shafts can lead to lock defects even if the electroplating surface is hard because the electroplating can be damaged and the soft main material is exposed to wear.

These test results are from NTN bench tests, and differ from actual operating conditions. Therefore, if non-tempered shafts are to be used, please consult with NTN.

3.2 Continuous idling rotation durability test results

If the units are to be used mostly in idle, reduction in the spring force to push the roller can lead to lock defects. The NTN NCZ type uses metal springs, so that lock reliability is better than for competing products that use resin springs.

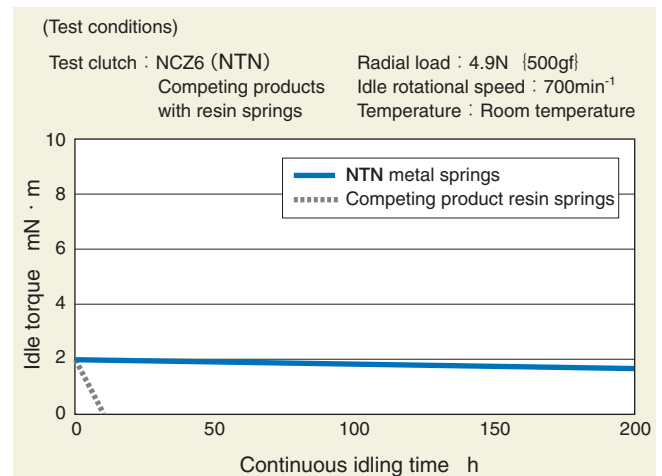

4. One-way Clutch



HF type

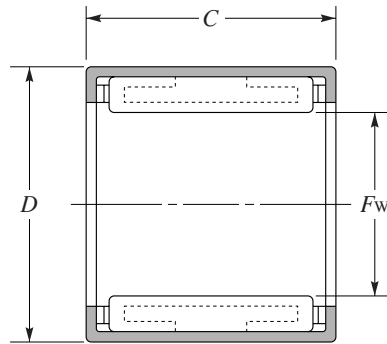

Shaft diameter mm	Name code	Dimensions mm			Torque capacity N · m {kgf · cm}	Mass g (Reference)
		F_w	D	$C_{-0.25}^0$		
6	HF0612	6	10	12	1.76 { 18 }	2.7
8	HF0812	8	12	12	3.15 { 32 }	3.4
10	HF1012	10	14	12	5.3 { 54 }	4.0
12	HF1216	12	18	16	12.2 { 124 }	12
14	HF1416	14	20	16	17.3 { 176 }	13
16	HF1616	16	22	16	20.5 { 209 }	15
18	HF1816	18	24	16	24.1 { 246 }	16
20	HF2016	20	26	16	28.5 { 291 }	18
25	HF2520	25	32	20	66 { 673 }	31
30	HF3020	30	37	20	90 { 918 }	36
35	HF3520	35	42	20	121 { 1230 }	41

HF type Radial load bearing

Select by referring to the bearings in the table below.

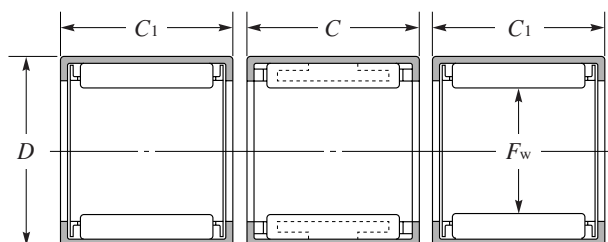

NTN shell-shaped needle roller bearing (HK type)

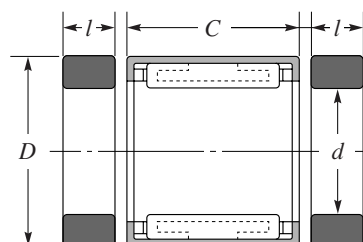

NTN BEARPHITE oil-impregnated bearing

Shaft diameter mm	One-way clutch name code	NTN shell-shaped needle roller bearing (HK type) ❶						NTN BEARPHITE oil-impregnated ❷			
		Name code	Dimensions mm			Basic rated load N kgf		Name code	Dimensions mm		
			F_w	D	C_1	C_r	C_{or}		d	D	l
6	HF0612	HK0609T2	6	10	9	2 660 272	2 280 233	B-S6-22	6	10	5
8	HF0812	HK0810C	8	12	10	3 850 395	3 950 400	B-S8-25	8	12	5
10	HF1012	HK1010 HK1012	10	14	10	4 500 460	5 100 520	B-S10-21	10	14	5
					12	5 900 605	7 250 735				
12	HF1216	HK1212	12	18	12	6 600 675	7 300 745	B-S12-32	12	18	5
14	HF1416	HK1412 HK1416	14	20	12	7 200 735	8 500 865	B-S14-13	14	20	5
					16	10 700 1090	14 000 1430				
16	HF1616	HK1612 HK1616	16	22	12	7 750 795	9 700 990	B-S16-13	16	22	8
					16	11 100 1130	15 300 1560				
18	HF1816	HK1812 HK1816	18	24	12	8 300 845	10 900 1110	B-S18-8	18	24	8
					16	11 800 1210	17 300 1760				
					20	13 000 1320	20 100 2050				
20	HF2016	HK2012C HK2016 HK2020C	20	26	12	9 250 945	13 000 1330	B-S20-19	20	26	10
					16	13 000 1320	20 100 2050				
					20	16 400 1670	27 100 2760				
25	HF2520	HK2512 HK2516 HK2520	25	32	12	11 800 1200	16 300 1660	B-S25-11	25	32	10
					16	15 900 1620	24 000 2450				
					20	20 300 2070	33 000 3350				
30	HF3020	HK3012 HK3016 HK3020	30	37	12	13 000 1320	19 500 1990	B-S30-19	30	37	10
					16	18 100 1850	30 000 3050				
					20	22 300 2280	39 500 4000				
35	HF3520	HK3512 HK3516 HK3520	35	42	12	14 000 1430	22 800 2320	B-S35-7	35	42	10
					16	19 700 2000	35 000 3600				
					20	24 800 2530	47 500 4850				

❶ NTN shell-shaped needle roller bearings include the closed end type (BK type) in addition to the open end type (HK type) listed above.

In addition, there are HK and BK types with seals (single seal or double seal).

Refer to Cat. No. 2300 "Needle Roller Bearings" for the features and assembly guidelines for shell-shaped needle roller bearings.

❷ NTN BEARPHITE oil-impregnated bearings are designed for an ideal radial clearance with the housing and shaft tolerances recommended on page 53.

If the width l of the NTN BEARPHITE oil-impregnated bearing is a problem due to the available space, please consult with NTN.

Refer to Cat. No. 5202 "BEARPHITE Oil-impregnated Bearings" for the features, loads, rotational speeds and installation dimensions of oil-impregnated bearing.

HFL type

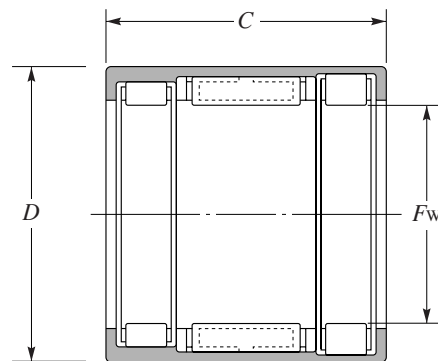

Shaft diameter mm	Name code	Dimensions mm			Torque capacity N · m kgf · cm	Basic rated load N kgf		Mass g (Reference)
		F_w	D	$C_{-0.25}^0$		C_r	C_{or}	
8	HFL0822	8	12	22	3.15 32	4 050 413	4 150 423	6.3
10	HFL1022	10	14	22	5.30 54	4 300 438	4 650 474	7.4
12	HFL1226	12	18	26	12.20 124	6 300 642	6 500 663	18
14	HFL1426	14	20	26	17.30 176	7 100 724	7 700 785	20
16	HFL1626	16	22	26	20.50 209	7 300 744	8 400 857	22
18	HFL1826	18	24	26	24.10 246	8 300 846	10 300 1050	24
20	HFL2026	20	26	26	28.50 291	8 200 836	10 400 1060	27
25	HFL2530	25	32	30	66.00 673	10 900 1110	14 100 1440	44
30	HFL3030	30	37	30	90.00 918	12 600 1280	17 600 1790	51
35	HFL3530	35	42	30	121.00 1230	13 000 1330	19 300 1970	58

NHF type

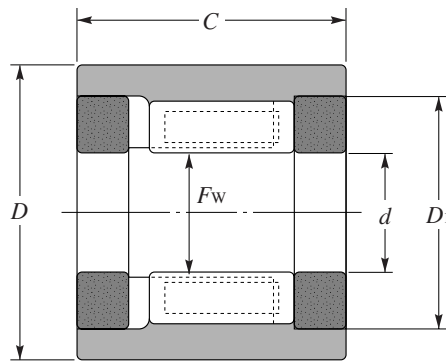

Shaft diameter mm F_w	Name code	Dimensions mm				Torque capacity N·m {kgf·cm}	Mass g (Reference)
		d	$D \begin{smallmatrix} +0.020 \\ 0 \end{smallmatrix}$	(D_1)	$C \begin{smallmatrix} 0 \\ -0.200 \end{smallmatrix}$		
4	NHF04	4 $\begin{smallmatrix} +0.050 \\ +0.020 \end{smallmatrix}$	10	8.4	9	0.29 { 3 }	3.4
6	NHF06	6 $\begin{smallmatrix} +0.055 \\ +0.020 \end{smallmatrix}$	12	10.4	10	0.69 { 7 }	4.7
8	NHF08	8 $\begin{smallmatrix} +0.055 \\ +0.020 \end{smallmatrix}$	16	13.5	13	2.06 {21}	11
10	NHF10	10 $\begin{smallmatrix} +0.060 \\ +0.020 \end{smallmatrix}$	18	15.5	14	3.14 {32}	14
12	NHF12	12 $\begin{smallmatrix} +0.065 \\ +0.020 \end{smallmatrix}$	20	17.5	15	4.61 {47}	18

5. One-way Clutch Units



NCU type, NCZ type, NCZC type (Standard Width Models)

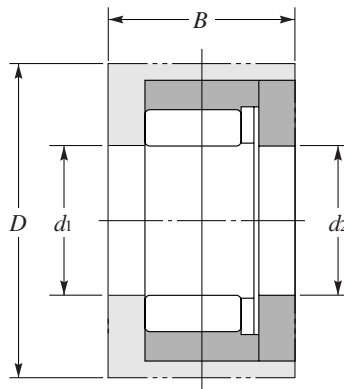

Shaft diameter mm	Name code	Dimensions mm				Torque capacity ^① N · m {kgf · cm}	Idling torque ^② mN · m {gf · cm}
		d_1	d_2	D	B		
4	NCU 4	4 ^{+0.10} / _{+0.02}	4 ^{+0.10} / _{+0.02}	12 min	9 min	0.20 {2}	2.94 {30}
6	NCZ 6	6 ^{+0.10} / _{+0.02}	6 ^{+0.12} / _{+0.02}	13.5 min	8 min	0.49 {5}	3.43 {35}
	NCZC 6			13 min	8 min	0.20 {2}	3.43 {35}
8	NCZ 8	8 ^{+0.10} / _{+0.02}	8 ^{+0.10} / _{+0.02}	16 min	8 min	0.78 {8}	4.90 {50}
10	NCU10	10 ^{+0.10} / _{+0.02}	10 ^{+0.10} / _{+0.02}	20 min	10 min	0.88 {9}	4.90 {50}

① The torque capacity is based on the NTN standard test conditions.

② Idling torque is the value when radial torque is not applied.

Oscillation angle: 10 degrees

Oscillation cycle: 300 cpm, 10⁶ times

Shaft used: SUJ2, tempered

Dimension tolerance: h7

NCZX type, NCUX type (Narrow Width Products)

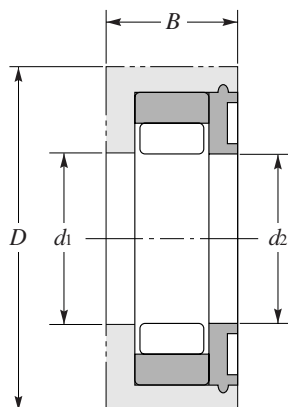

Shaft diameter mm	Name code	Dimensions mm				Torque capacity ^① N · m {kgf · cm}	Idling torque ^② mN · m {gf · cm}
		d_1	d_2	D	B		
4	NCUX 4	4 $\begin{smallmatrix} +0.10 \\ +0.02 \end{smallmatrix}$	4 $\begin{smallmatrix} +0.10 \\ +0.02 \end{smallmatrix}$	11.5 min	5 min	0.10 {1}	2.94 {30}
6	NCZX 6	6 $\begin{smallmatrix} +0.10 \\ +0.02 \end{smallmatrix}$	6 $\begin{smallmatrix} +0.12 \\ +0.02 \end{smallmatrix}$	13.5 min	5 min	0.20 {2}	3.43 {35}
8	NCZX 8	8 $\begin{smallmatrix} +0.10 \\ +0.02 \end{smallmatrix}$	8 $\begin{smallmatrix} +0.10 \\ +0.20 \end{smallmatrix}$	16 min	5 min	0.34 {3.5}	3.92 {40}

- ① The torque capacity is based on the NTN standard test conditions.
 ② Idling torque is the value when radial torque is not applied.

Oscillation angle: 10 degrees
 Oscillation cycle: 300 cpm, 10^6 times
 Shaft used: SUJ2, tempered
 Dimension tolerance: h7

6. Torque Diodes

- If the input shaft is rotated, the output shaft also rotates.
- The output shaft cannot cause the input shaft to rotate.

The following is a description of the free type and lock type, their features and their operating principles.

6.1 Free type torque diode (TDF)

6.1.1 Features

- When the input shaft is rotated, the output shaft also rotates.
- When the output shaft is rotated, it will rotate freely, but the movement is not transmitted to the input shaft.

6.1.2 Construction



VAD 312-V
Torque Diode®

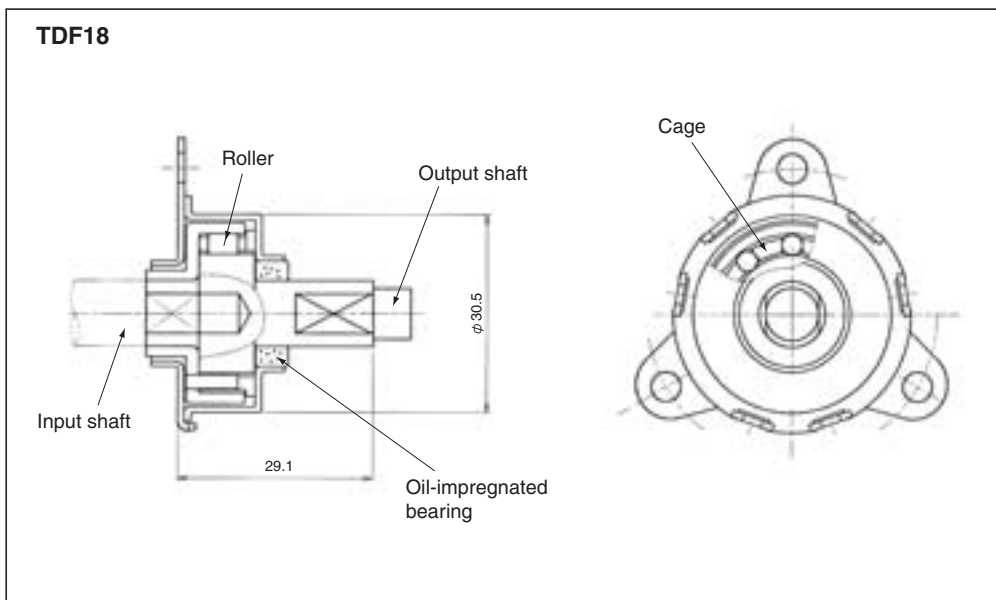

6.1.3 Operating principle

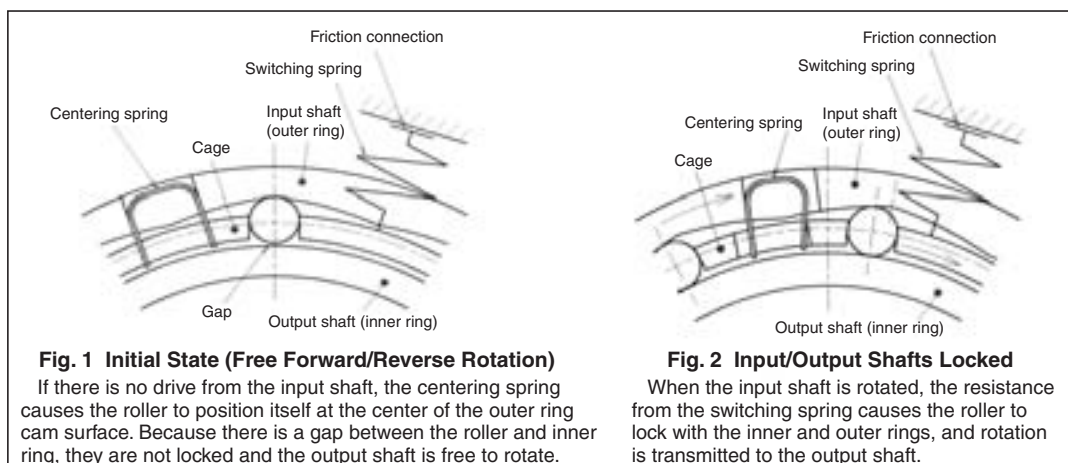

6.1.4 Technical data

TDF18 specification
Allowed load torque: 4.9 N·m {50kgf·cm}

6.1.5 Uses

Devices to prevent reverse input, automatic/manual switching mechanisms, geared motors, etc.

Do not use these bearings in areas where they may have impact on personal safety.

6.2 Lock type torque diode (TDL)

6.2.1 Features

- When the input shaft is rotated, the output shaft also rotates.
- If the output shaft is rotated, the output side is locked and movement is not transmitted to the input shaft.

6.2.2 Construction

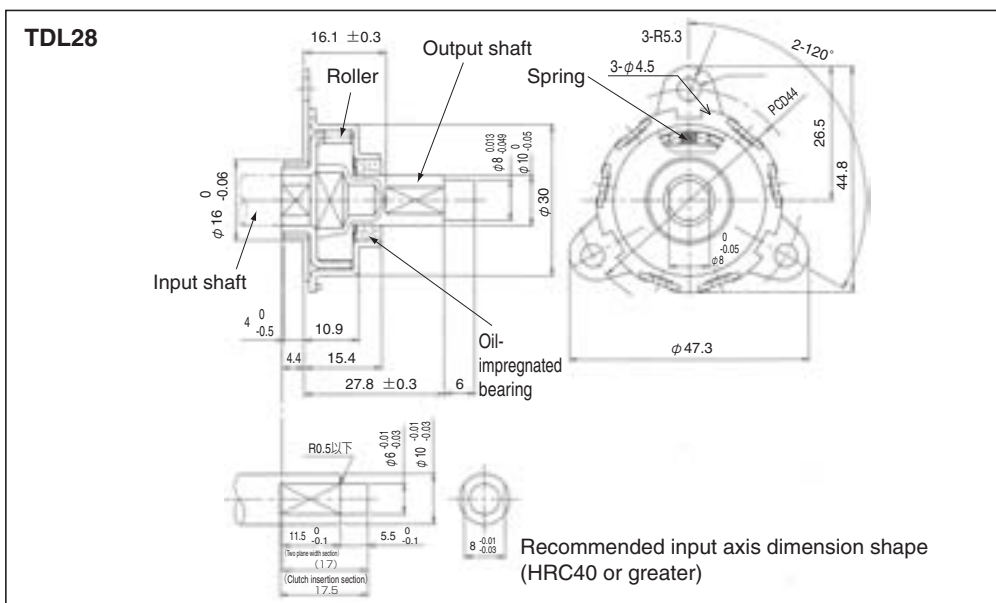

6.2.3 Operating principle

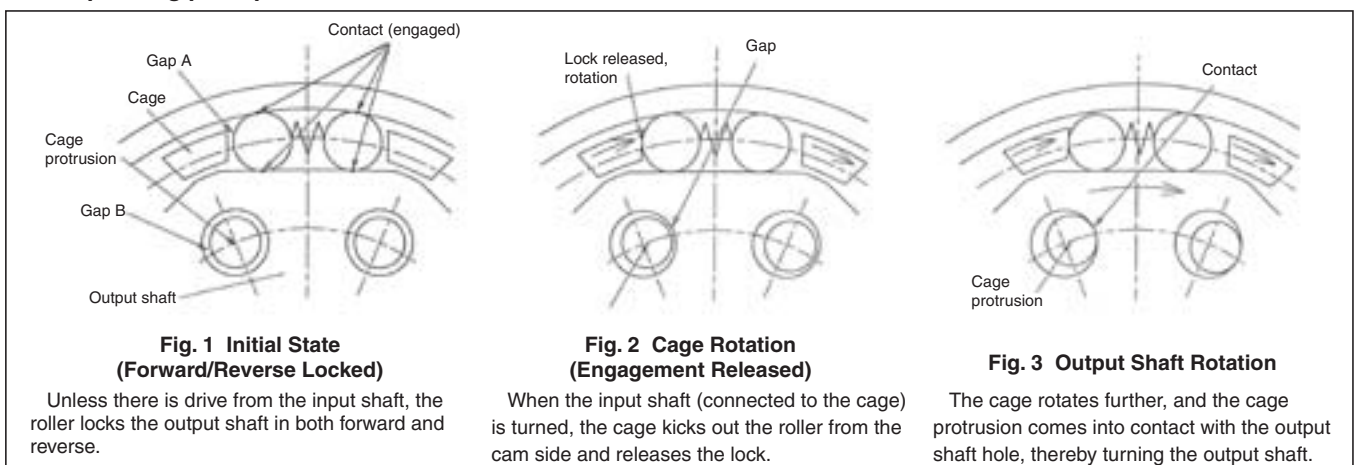

6.2.4 Technical data

TDL28 specification
Allowed load torque: 4.9 N·m {50kgf·cm}

6.2.5 Uses

Devices to prevent reverse input, drop-off preventing mechanism, geared motors, etc.

Do not use these bearings in areas where they may have impact on personal safety.

7. Introduction to Products Being Developed-1

Single-direction Rotation Conversion Unit: Mono Drive

Regardless of the rotational direction of the input shaft, the output shaft only rotates in one direction.

■ Single shaft type

The input and output shafts are coaxial. Torque capacity: $0.20\text{--}0.49\text{ N}\cdot\text{m}$ { $2\sim 5\text{kgf}\cdot\text{cm}$ }

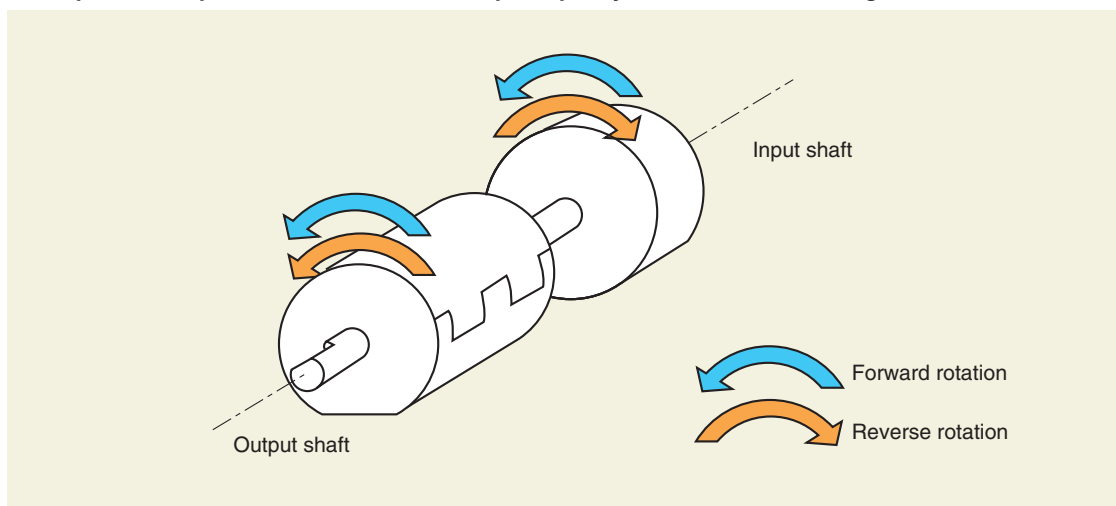

■ Double shaft type

The input and output shafts are not coaxial. Torque capacity: $0.49\text{ N}\cdot\text{m}$ { $5\text{kgf}\cdot\text{cm}$ }

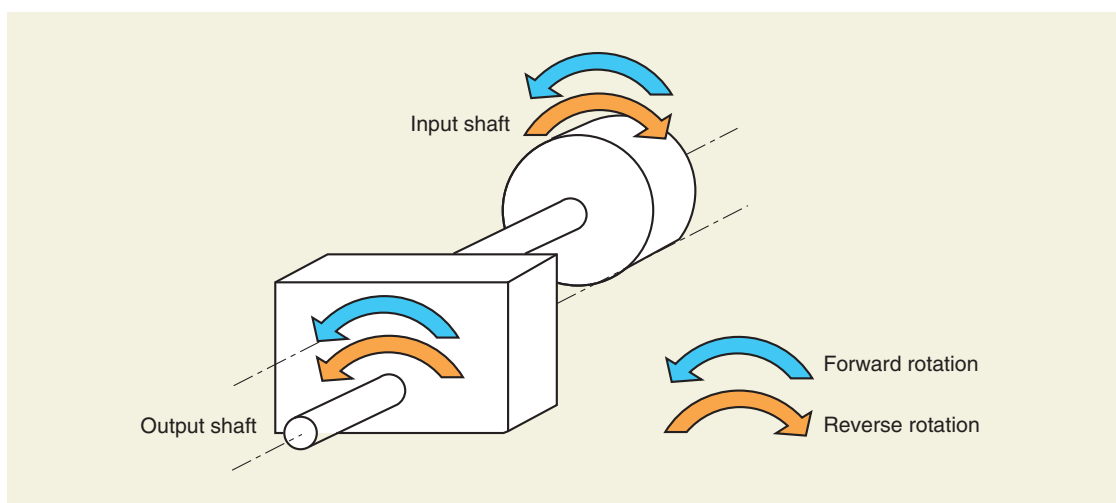

7. Introduction to Products Being Developed-2

Ultra Small One-way Clutch

A compact design that combines a one-way clutch and shaft.



Overview

A totally new concept in which a one-way clutch mechanism is built into the shaft. This unit has reduced the size of the unit to about the same as that of a shaft alone.

Compared with conventional models in which one-way clutches are inserted into shafts, the external dimensions have been reduced to 50% ($A/B = 0.5$), making it practical to use this in hinge units and the like where space is at a premium.

Appearance

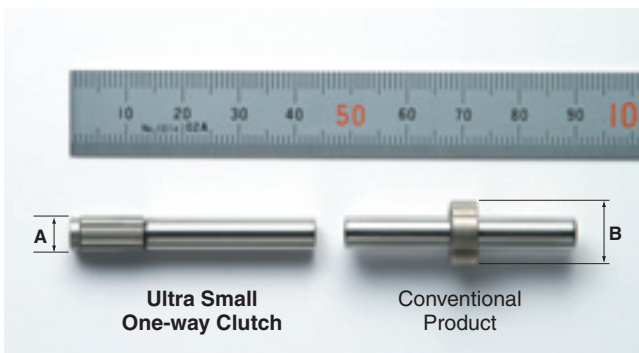

Features

(1) Ultra compact:

An outer diameter of 6 mm realized for the first time in the world. With a 0.2 N·m {2 kgf·cm} unit, the external dimension has been reduced 50% ($A/B = 0.5$). (NTN data)

(2) Reliable lock mechanism:

Highly reliable lock function assured with a roller clutch mechanism using the wedge effect.

(3) Improved assembly:

A protrusion has been added to the outer diameter of the clutch, so that the resin molded parts will stop sliding and fit perfectly.

(4) Extremely durable

Durability test results

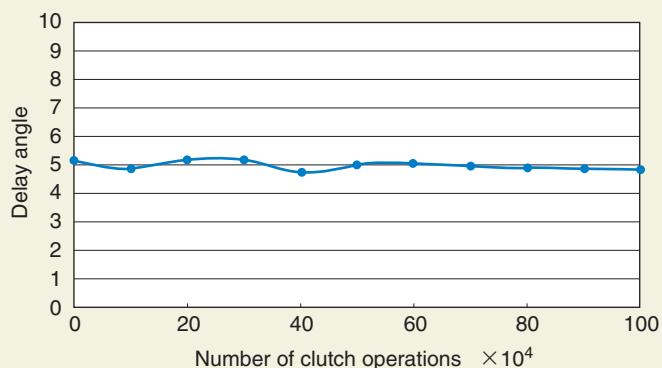

7. Introduction to Products Being Developed-3

Compact and Lightweight Torque Diode (Lock Type/TDL16)

■ Features of the compact and lightweight torque diode (lock type)

- When the input shaft of a torque diode (lock type) is rotated, the output shaft also rotates in both directions, but the output shaft has a function that does not allow it to rotate in both directions. Currently, we supply the TDL28 for this type of use. We have developed the TDL16 which is 80% smaller than the TDL28 (when compared at the outer diameter) and 50% lighter.

■ Performance

- Allowed load torque: 2.45N·m {25kgf·cm} (The service life will differ depending on the operating rotational speed and continuous operating time.)
Weight: 35 g (for the shape below)

■ Usage

- Sorter tray drives
- ADF drives
- Protective mechanismst

※ Do not use these bearings in areas where personal safety depends on them.

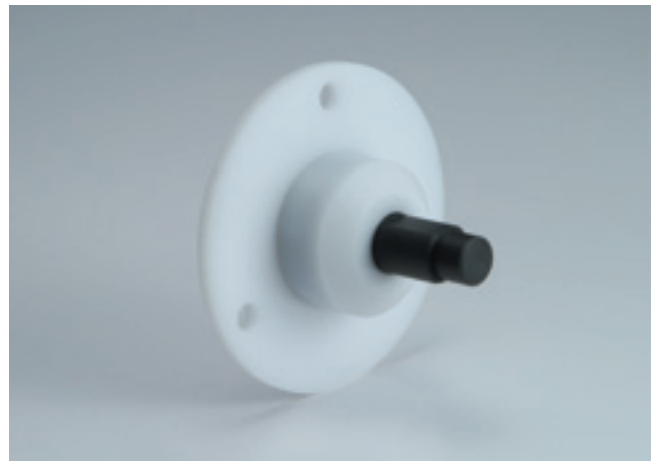

■ Dimensions

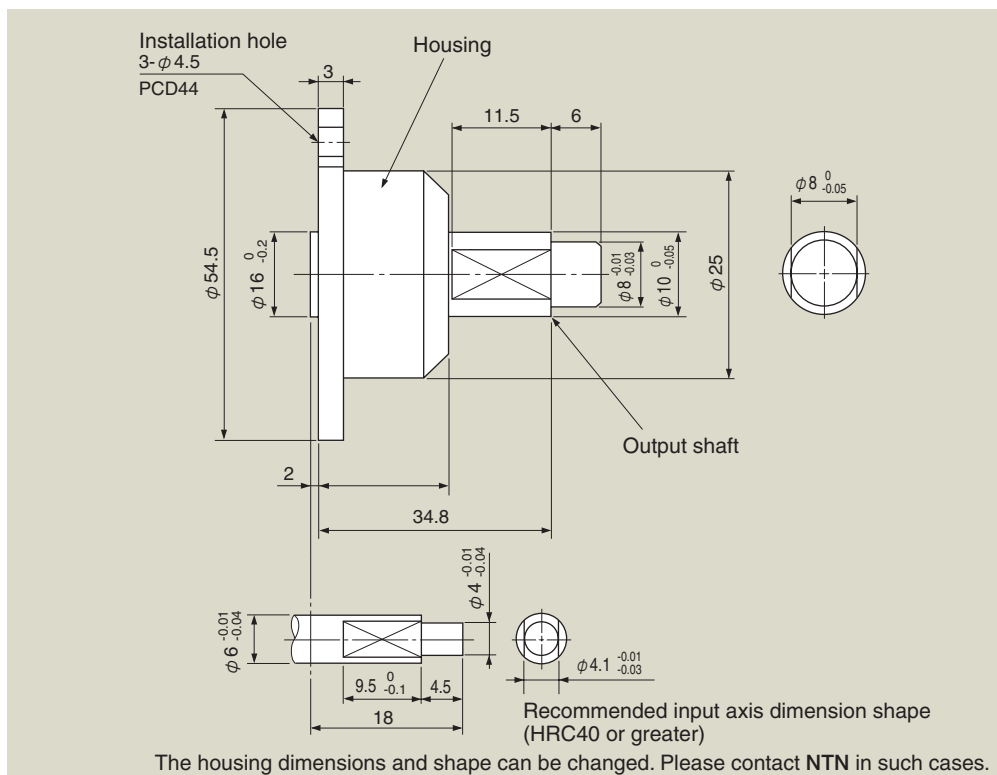

Catalogs for Office Equipment Related Products

The “NTN General Office Equipment Product Catalog” lists products mainly for photocopiers and printers. The following NTN product catalogs are available for these products. Please ask your nearest NTN branch office or sales office for these catalogs.

Catalog	Catalog No.
●Ball and Roller bearings	
Ball and Roller Bearings	2202/E
Ball Bearing / Shield and Seal Types	3015/E
Miniature and Extra Small Ball Bearings	3013/E
Integrated Rotation Sensor Bearings	3032/E
Bearings for Special Environments / Ultra Final Series	3023/E
Ultra Final Series / Bearings for Clean Environment	3028/E
●Slide Bearings	
BEAREE (High Performance Multi-Purpose Engineering Plastics)	5100/E
Plastic Sliding Screws	5112/E
BEARPHITE Oil-impregnated Sintered Bearings	5202/JE
●Needle Bearings	
Needle Roller Bearings	2300/E
HK-F Type Drawn Cup Needle Roller Bearings	3029/JE
Cam Followers & Roller Followers	3604/JE
●Other	
New Products Guide	9208/E
Bearing Handling	9103/E
Care and Maintenance of Bearings	3017/E
●Handbooks	
Rolling Bearings Handbook	9012/E
Needle Roller Bearings Handbook	9013/E

Remarks: The catalog numbers listed here are the basic numbers. Revision numbers (-II, III, etc.) shall be added to these when there are revisions