

## Table of Contents

### Rolling Mill Bearings

Introduction
Ball Bearings
Cylindrical Roller Bearings
Spherical Roller Bearings
Tapered Roller Bearings
Thrust Bearings
Split Pillow Blocks
Super Precision Bearings
Linear Motion
<b>Rolling Mill Bearings</b>
Engineering Section

<b>INTRODUCTION</b>
About NSK Rolling Mill Bearings . . . . .283
<b>NOMENCLATURE</b>
Four Row Roller Bearings . . . . .284
Two Row Tapered Roller Bearings . . . . .284
Angular Contacts . . . . .285
<b>APPLICATION</b>
Rolling Mill Bearings . . . . .286

## Introduction

### ABOUT NSK ROLLING MILL BEARINGS

- Four Row Tapered Roller Bearings
- Four Row Cylindrical Roller Bearings
- Two Row Tapered Roller Bearings
- Angular Contact Ball Bearings

**Four Row Tapered** roller bearings are very popular for use on roll necks. Most of these bearings are composed of two double cones (four Inner ring raceways), a cone spacer, two single cups (one at each end), one double cone (the center two raceways in the outer rings), and two cup spacers. They are very effective at operating under heavy radial and axial loads at low to moderate speeds. NSK four row tapered bearings are standardly supplied with carburized rings and rollers and are compatible with industry standards. "Sealed-Clean" bearings are four row tapers with seals for the harshest of operating environments. NSK's patented design provides the optimum sealing efficiency with only a slight loss of capacity.

**Four Row Cylindrical** roller bearings are also popular roll neck bearings providing several benefits. First, the inner ring is separable from the outer ring and rollers which allows the inner ring to remain with the roll during grinding processes. This assures precise concentricity and negligible run-out providing for high rolling accuracy. Secondly, this design allows for greater radial load carrying and higher operating speeds. Four row cylindricals require a thrust bearing which is usually a two row taper, angular contact ball bearing, or a deep groove ball bearing depending on the thrust load present.

**Two Row Tapered** roller bearings are very common as the back-up thrust bearing in a rolling mill or as the roll neck in lighter duty rolling mills. Two row tapers are designed in a variety of styles for different applications. Converging bearings (TDI,TDIE,TDIS) consist of one double cone and two single cups possibly with a cup spacer. Diverging bearings (TDO,TDOD,TDOC) consist of two single cones, a cone spacer, and one double cup.

**Angular Contact** ball bearings are used as thrust bearings for roll necks using four row cylindricals and having lighter load requirements. These bearings can only accept axial loads in one direction so they are used in sets of two with the contact angles diverging.

## Nomenclature — Four Row Roller Bearings

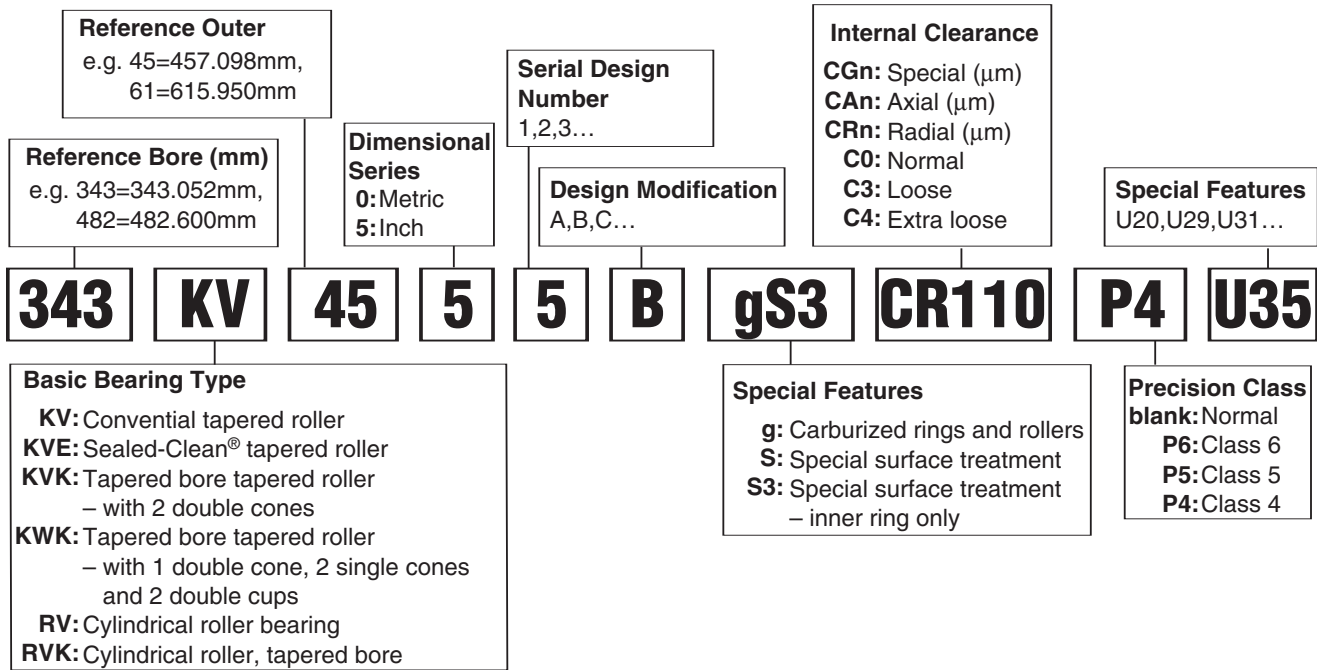

## Nomenclature — Two Row Tapered Roller Bearings

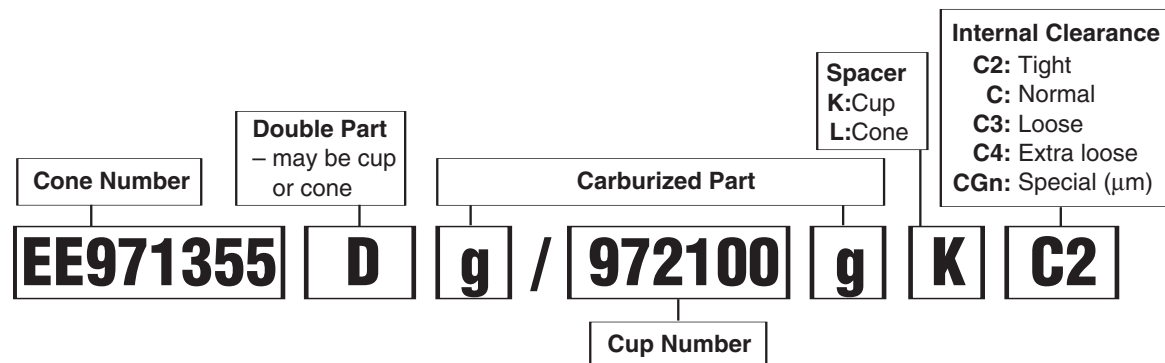
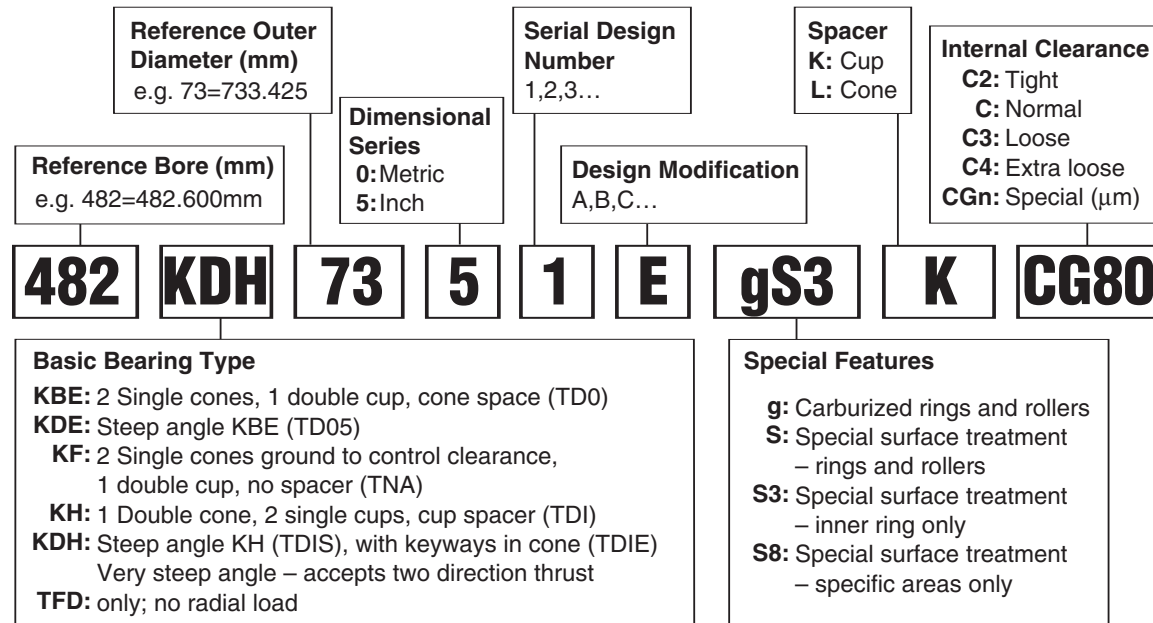

## Nomenclature — Angular Contacts

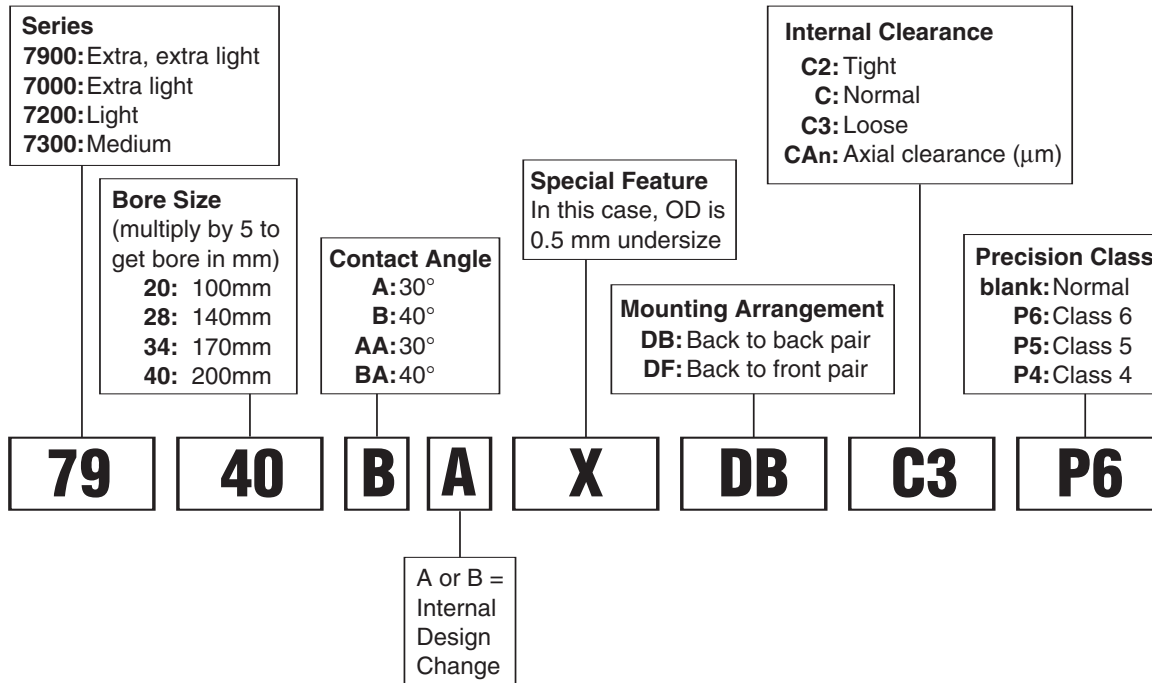
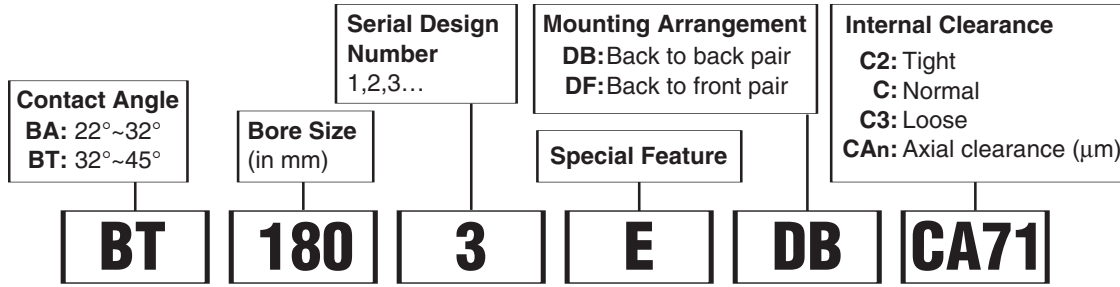

## Guide Roll for Continuous Slab Caster

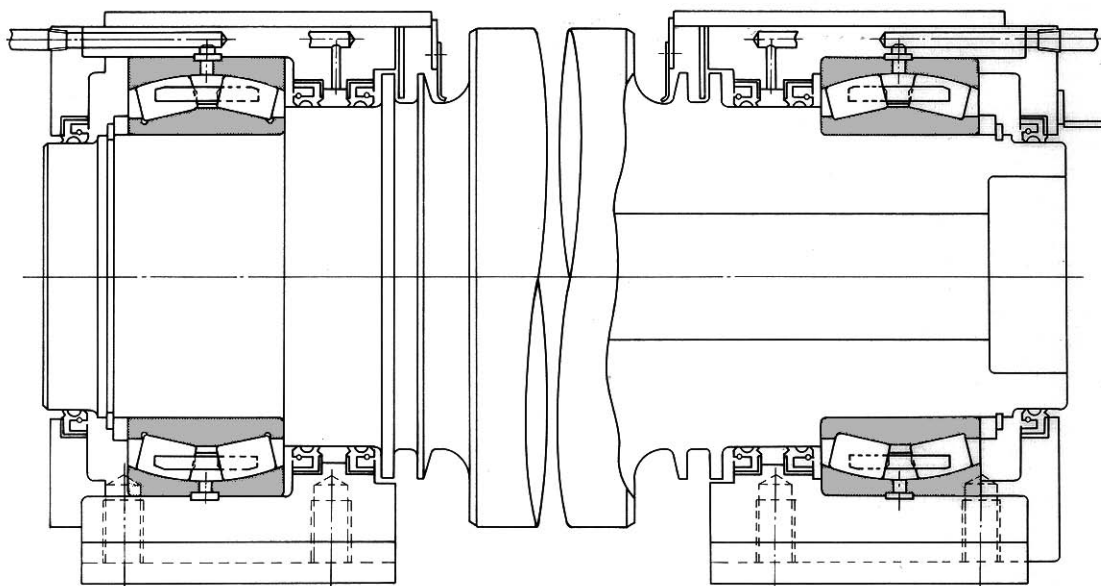

Spherical roller bearings are the most common bearing type used in continuous casting machines. Their excellent load carrying capacity and ability to handle misalignment due to shaft deflection makes them a natural for this application. The bearings are generally grease lubricated and usually have a loose fit between the bearing and both the shaft and housing.

## Sealed-Clean Bearings for Guide Rolls and Pinch Rolls in Continuous Casters

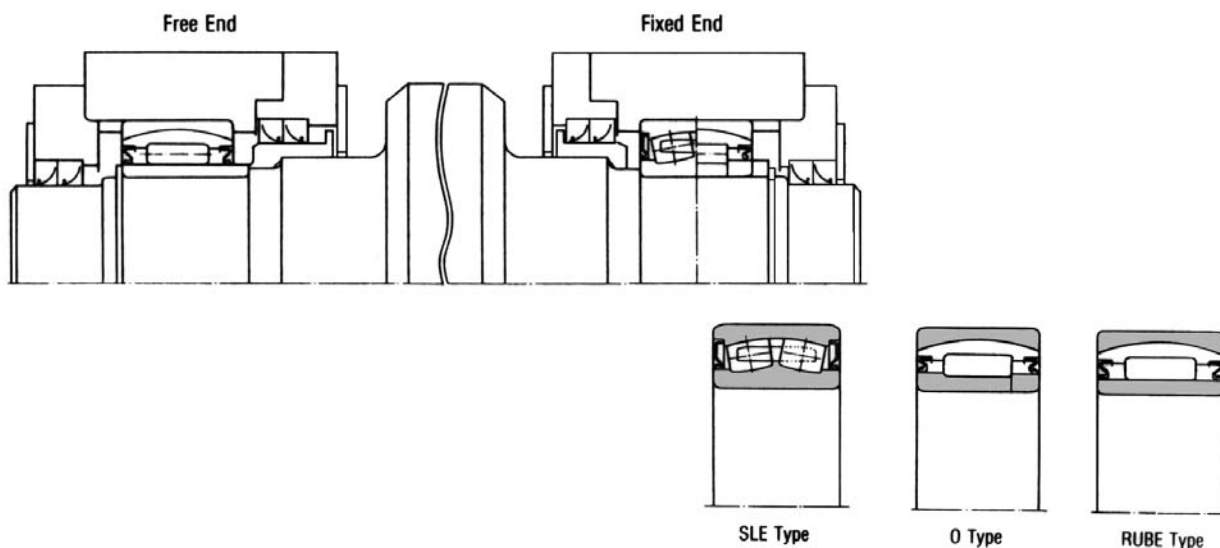

Sealed roller bearings provide extra protection against the water and scale common in continuous casting machines. These bearings are available in two basic types: cylindrical roller bearings with spherical alignment rings, RUBE type, and spherical roller bearings, SLE type. Either type can be supplied with a single seal, when replenishment of grease is desirable, or completely sealed and pre-packed with a high quality grease. Spherical roller bearings are recommended for fixed end positions while the self-aligning cylindrical roller bearings provide advantages for the float end position.

## Work Roll Bearing Arrangement for Slabbing Mills

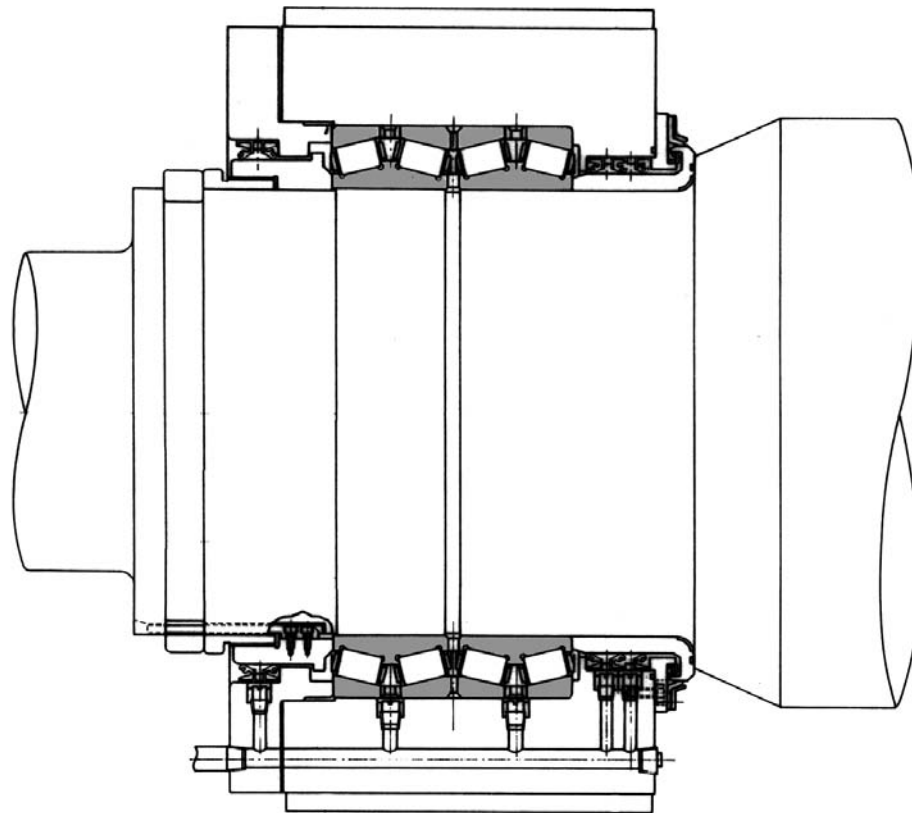

Large four-row tapered roller bearings, NSK KV type, are the most common bearings for work rolls in slabbing mills. Their ability to support high radial loads combined with axial loads make them a perfect choice. They have a loose fit with the roll and the housing and may be lubricated using grease, oil mist or oil-air systems.

## Workroll Bearing Arrangement for Slabbing Mills or Universal Beam Mill

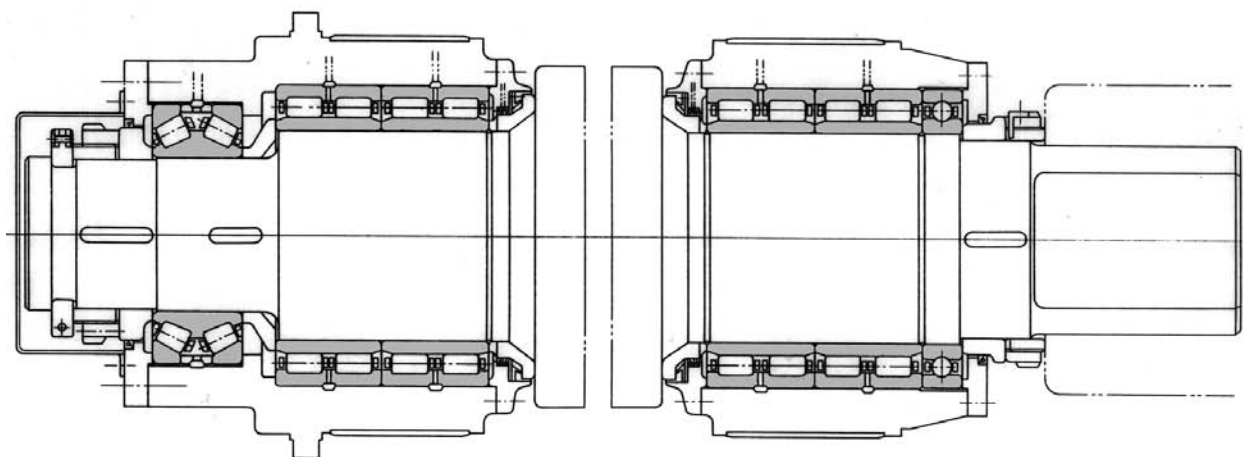

Because of the heavy loads, NSK RV type, four row cylindrical roller bearings are normally used. The bearing inner races are heat shrink fitted onto the rollneck and will remain with the rolls. The diameter under the rollers is held very precisely to insure that they can be used interchangeably with all inner rings. The inner races have NSK specially designed chamfers to assist in the easy installation of the chocks to the workrolls. The high axial forces are countered by a steep angle tapered roller thrust bearing, NSK KDH type. This is mounted in the operator side chock. A large diameter ball bearing, NSK 60xx or B type, is mounted in the drive side and unitizes the chock to the workroll.

## Work Roll Bearing Arrangement for Four-High Plate Mill

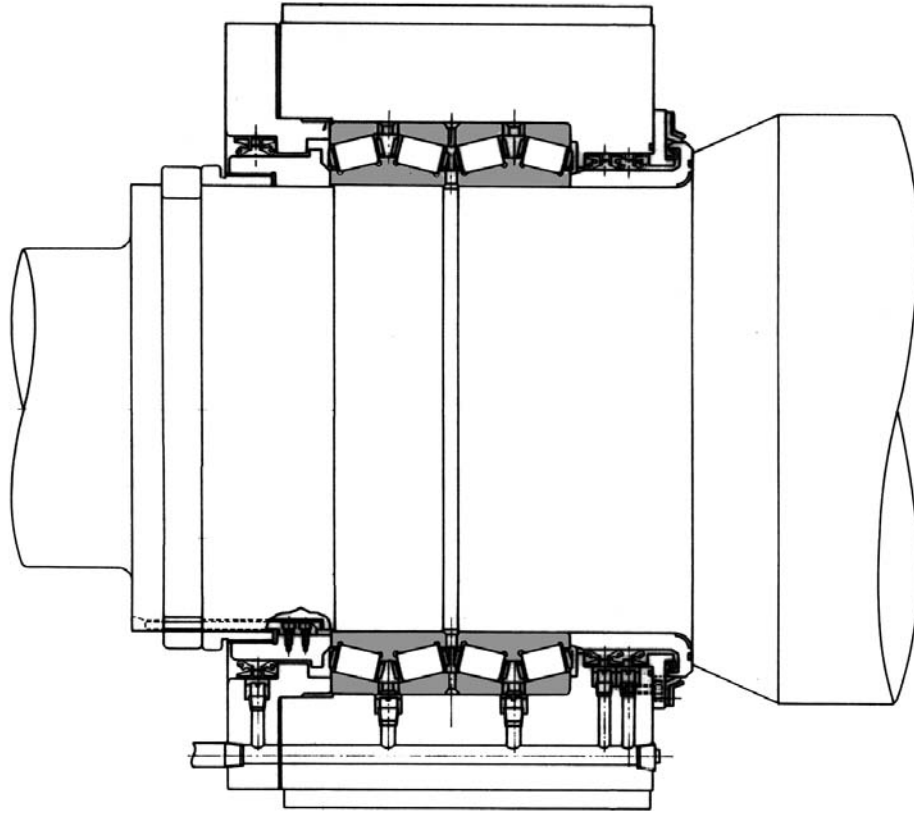

Large four-row tapered roller bearings, NSK KV type, are the most common bearings for work rolls in slabbery mills. Their ability to support high radial loads combined with axial loads make them a perfect choice. They have a loose fit with the roll and the housing and may be lubricated using grease, oil mist or oil-air systems.

Introduction

Ball Bearings

Cylindrical Roller Bearings

Spherical Roller Bearings

Tapered Roller Bearings

Thrust Bearings

Split Pillow Blocks

Super Precision Bearings

Linear Motion

Rolling Mill Bearings

Engineering Section

## Vertical Edger Rolls for Roughing Section of Finishing Mill

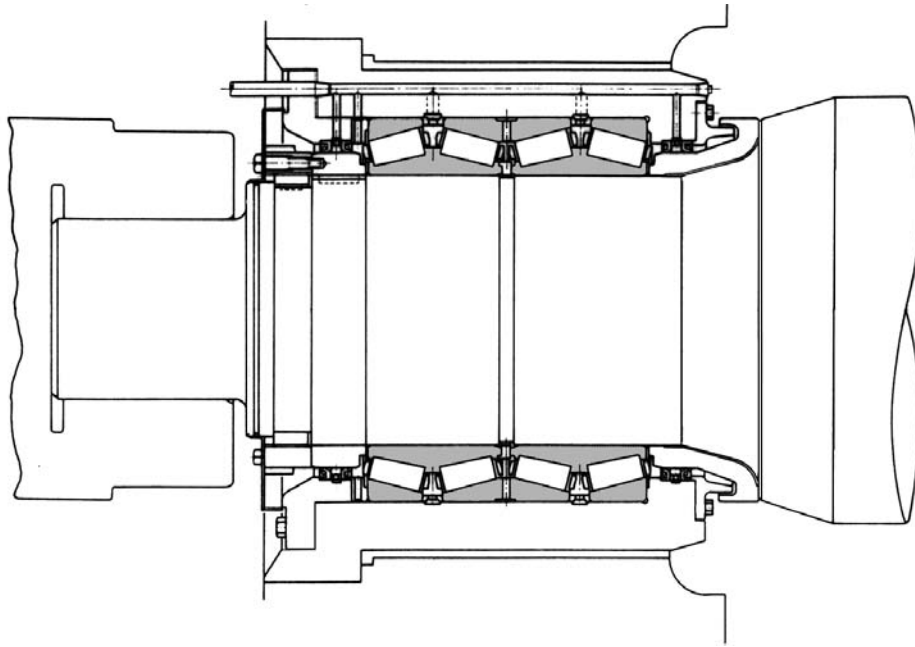

Bearings used in this application must have high radial and axial load carrying capacity. Therefore, NSK KV type, four roll tapered roller bearings and in some mills, NSK KH type, two roll tapered roller bearings are used. Special heavy duty roller retainer designs are used because of the high axial forces and misalignment. Low radial internal clearance insures that there is even load distribution across the bearing. Loose fits are used on both the inner and outer rings.

Introduction

Ball Bearings

Cylindrical Roller Bearings

Spherical Roller Bearings

Tapered Roller Bearings

Thrust Bearings

Split Pillow Blocks

Super Precision Bearings

Linear Motion

Rolling Mill Bearings

Engineering Section



## Workroll Bearing Arrangement for Hot Strip, Roughing, and Finishing Mills

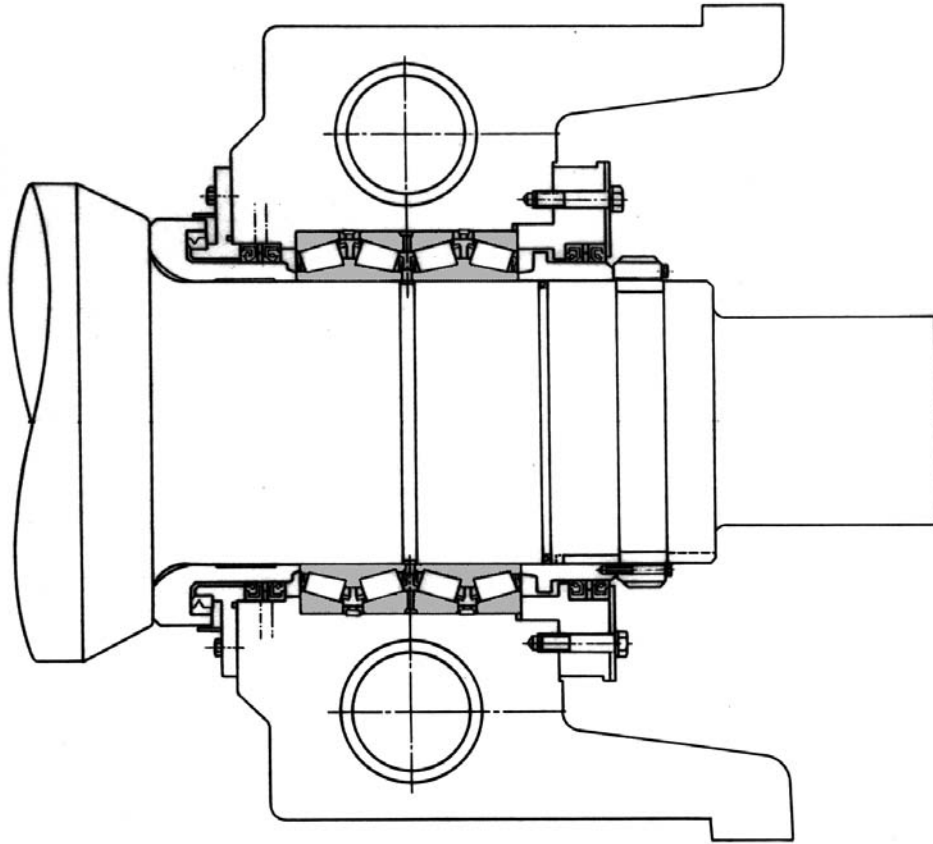

Workrolls in 4 high rolling mills use four row tapered roller bearings, NSK KV type. These bearings are slightly larger in size than those found in cold mills and also offers high capacity in both the radial and axial directions. The bearings are designed to be used with grease, oil mist, or oil-air system. Both the inner and outer rings are loose fitted.

Introduction

Ball Bearings

Cylindrical Roller Bearings

Spherical Roller Bearings

Tapered Roller Bearings

Thrust Bearings

Split Pillow Blocks

Super Precision Bearings

Linear Motion

Rolling Mill Bearings

Engineering Section

## Sealed Clean Bearings for Hot Strip Mill Runout Tables

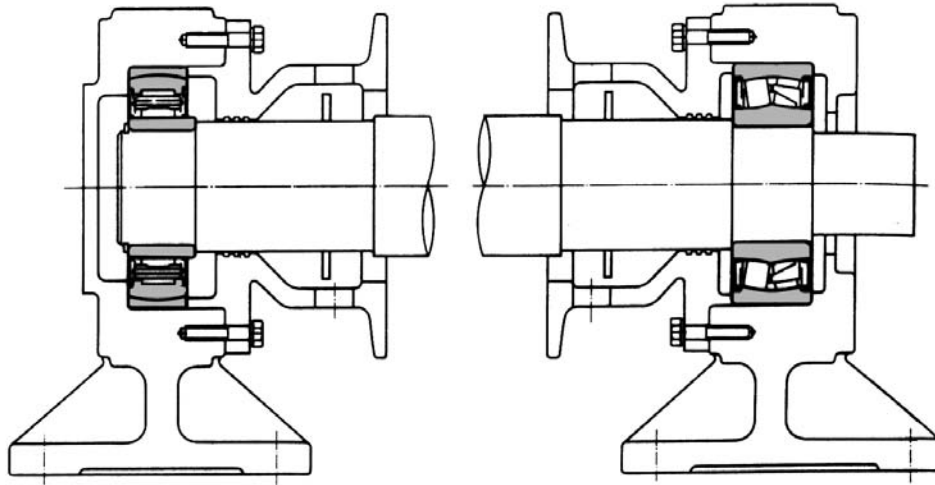

Spherical roller bearings, NSK SLE, and self-aligning cylindrical roller bearings, NSK RUBE types, are used on many runout tables. The spherical roller bearings fix the rolls and provide axial loading capability. Because of the large amount of thermal expansion of rolls, the cylindrical roller bearings allows for free movement. Expansion is taken between the inner ring and rollers eliminating the problems encountered when trying to take float in the housing. Bearings seals offer extra protection to the bearings when the typical mode of failure is contamination or inadequate lubrication.

## Sealed Clean Workroll Bearing Arrangement for Cold Strip, Hot Strip, and Temper Mills

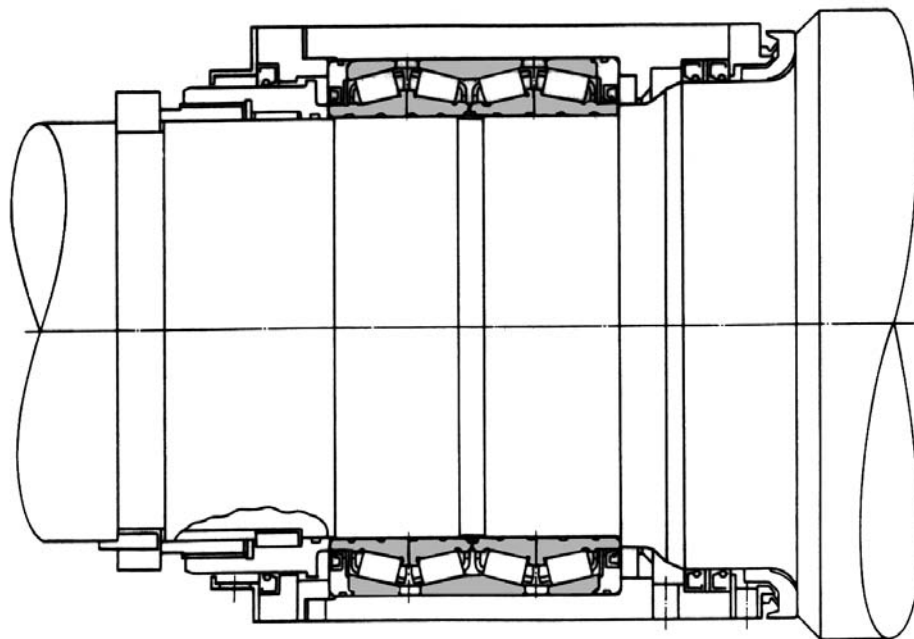

The NSK Sealed Clean Rollneck Bearings, KVE type, have replaced the conventional workroll bearings in many mills. Because they are sealed, they are better protected from rolling coolant and scale. Grease is packed in the bearings at installation and no further greasing is required for several months. This cuts operating costs substantially.

## Workroll Bearing Arrangement for Cold Strip and Temper Mills

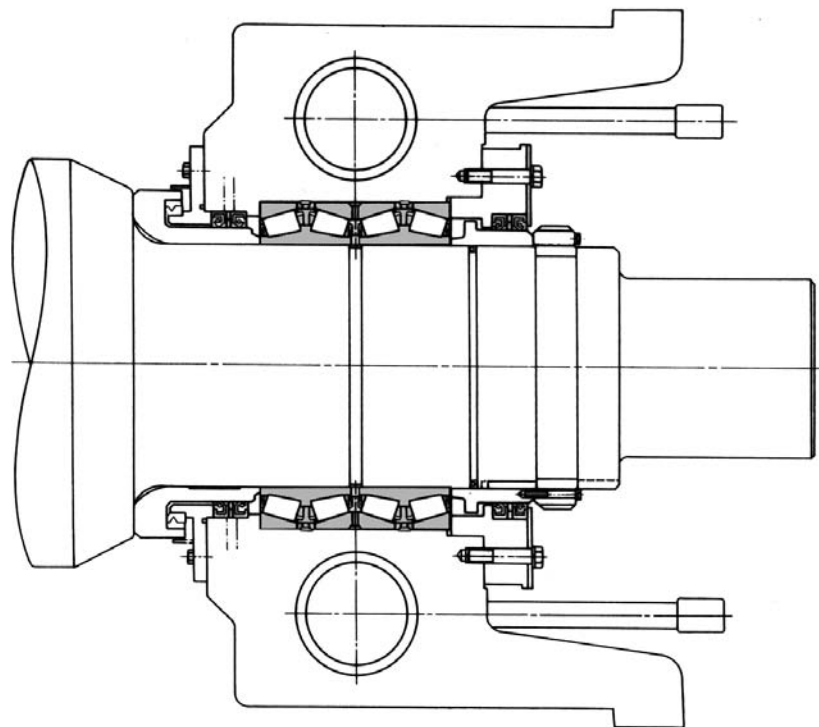

Most workrolls in a 4 high rolling mills use four row tapered roller bearings, NSK KV type. This bearing offers high capacity in both the radial and axial directions. The bearings are designed to be used with grease, oil mist, or oil-air system. Both the inner and outer rings are loose fitted. The intermediate roll of the modern 6 high mills also use this bearing.

Introduction

Ball Bearings

Cylindrical Roller Bearings

Spherical Roller Bearings

Tapered Roller Bearings

Thrust Bearings

Split Pillow Blocks

Super Precision Bearings

Linear Motion

Rolling Mill Bearings

Engineering Section

## Back Up Roll for Strip Mills

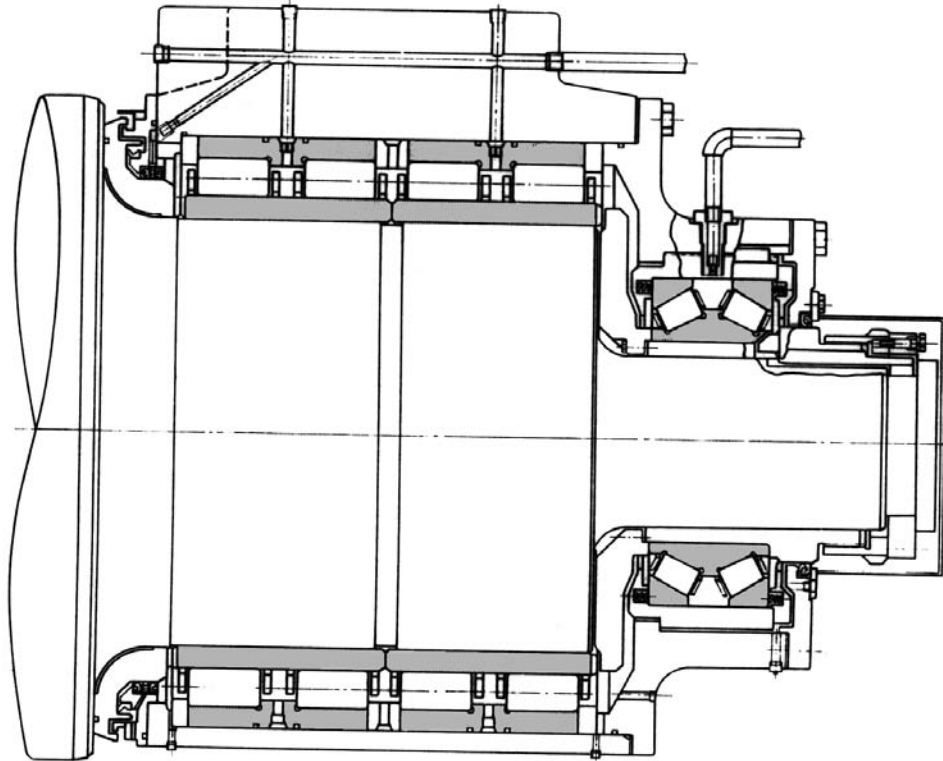

When high rolling accuracy is required, NSK RV type, four row cylindrical roller bearings are normally used. The bearings are supplied with better than normal running accuracies and controlled radial internal clearance. The inner rings are shrink mounted on the rollneck and the raceways are finish ground to further control the accuracy and clearance. The high axial forces are countered by a steep angle tapered roller thrust bearing, NSK KDH type, mounted in the operator side chock.

## Screwdown Thrust Bearings for Strip Mills

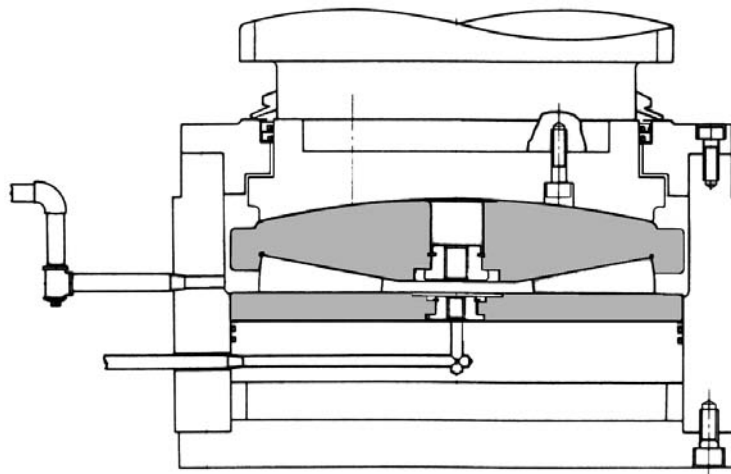

These high capacity tapered roller thrust bearings, NSK TFX type, sits on top of the top back up roll chock and is subjected to the hundreds of tons of rolling force. The spherical surface on the top race compensates for the misalignment created by the heavy load. Drip feed oil is used to lubricate these bearings.

## Roll for Intermediate Stand of a Wire Mill

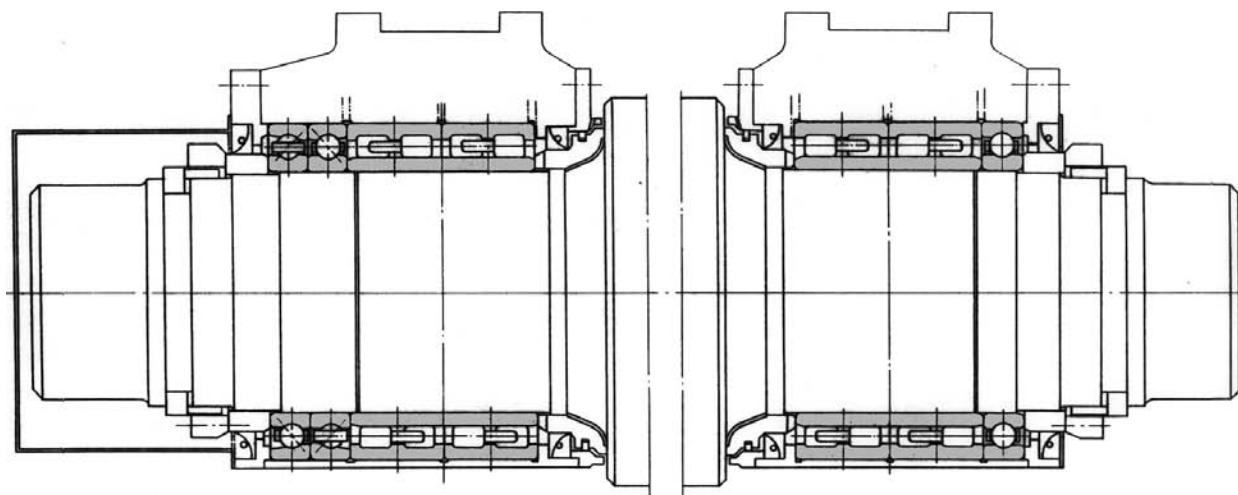

Four-row cylindrical roller bearings, **NSK RV** Type, provide an excellent combination of high load capacity, high speed capability and high running accuracy. The inner rings are tight fitted on the shaft and are interchangeable from one bearing to another. A pair of large angular contact ball bearings, **BAxxx** type, in the operator side chock support thrust loads while a single ball bearing maintains the axial relationship between the drive side chock and the roll.

Introduction

Ball Bearings

Cylindrical Roller Bearings

Spherical Roller Bearings

Tapered Roller Bearings

Thrust Bearings

Split Pillow Blocks

Super Precision Bearings

Linear Motion

Rolling Mill Bearings

Engineering Section

## Back-up for a Four-High Reversing Hot Mill for Aluminum

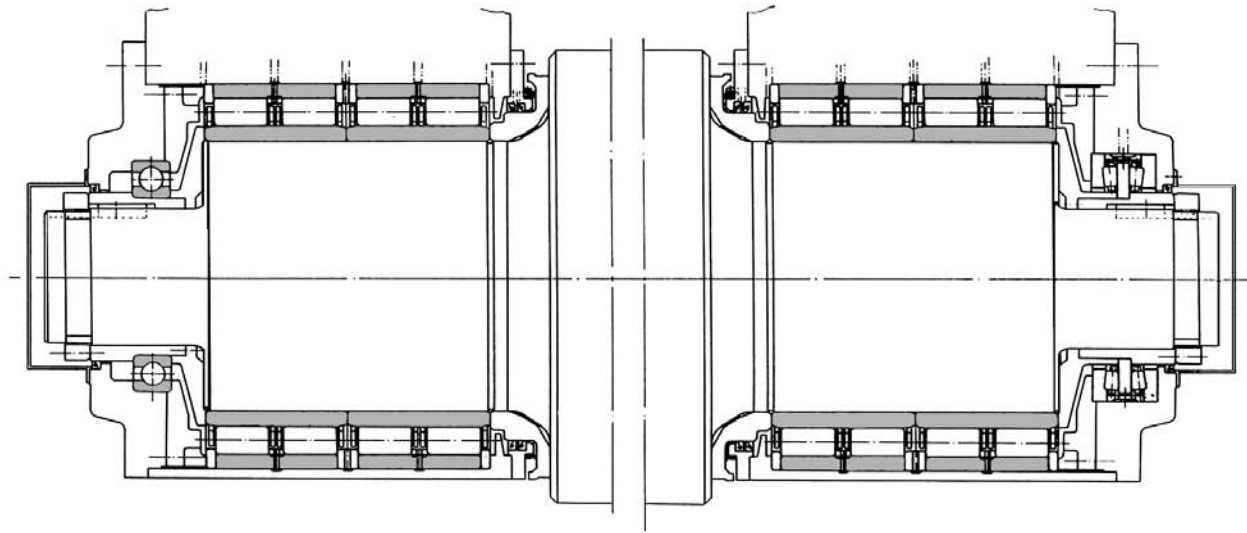

Four-row cylindrical roller bearings, **NSK RV** type, provide high load capacity necessary to support rolling loads while maintaining good accuracy. The inner rings are tight fitted to the rolls and are interchangeable from one bearing to another. A two-row tapered roller thrust bearing supports axial loads and a large ball bearing unitizes the drive side chock.

Introduction

Ball Bearings

Cylindrical Roller Bearings

Spherical Roller Bearings

Tapered Roller Bearings

Thrust Bearings

Split Pillow Blocks

Super Precision Bearings

Linear Motion

Rolling Mill Bearings

Engineering Section

## Back-up Roll Assembly for Sendzimir-Type Cluster Mill

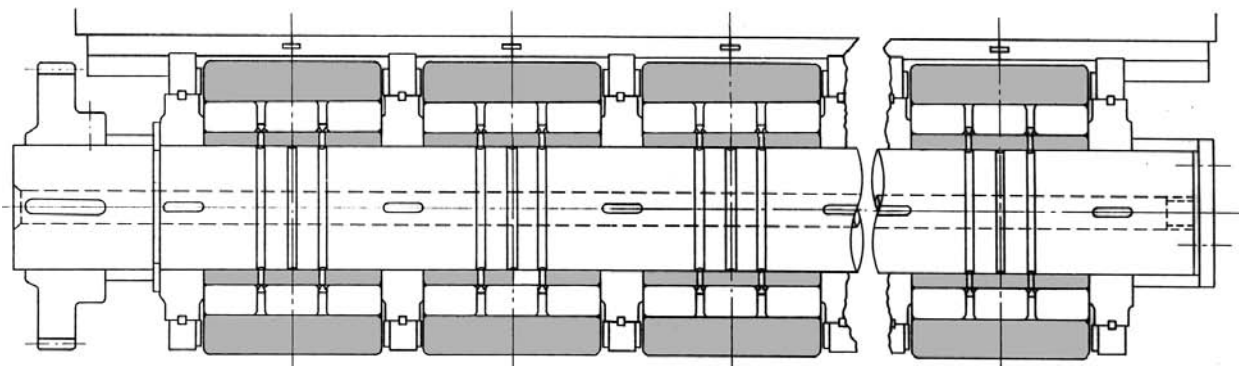

High running accuracy and careful matching of sets are an important feature for these bearings. The type of rolling element and the number of rows of rolling elements varies, but three rows of cylindrical rollers, NSK 3PLxxx type, is common. The inner rings are stationary on the shaft while the outer rings function as back-up rolls. Oil is supplied through the shaft to lubricate the bearings.

Introduction

Ball Bearings

Cylindrical Roller Bearings

Spherical Roller Bearings

Tapered Roller Bearings

Thrust Bearings

Split Pillow Blocks

Super Precision Bearings

Linear Motion

Rolling Mill Bearings

Engineering Section

## Roll Unit Bearings for Tension Levelers

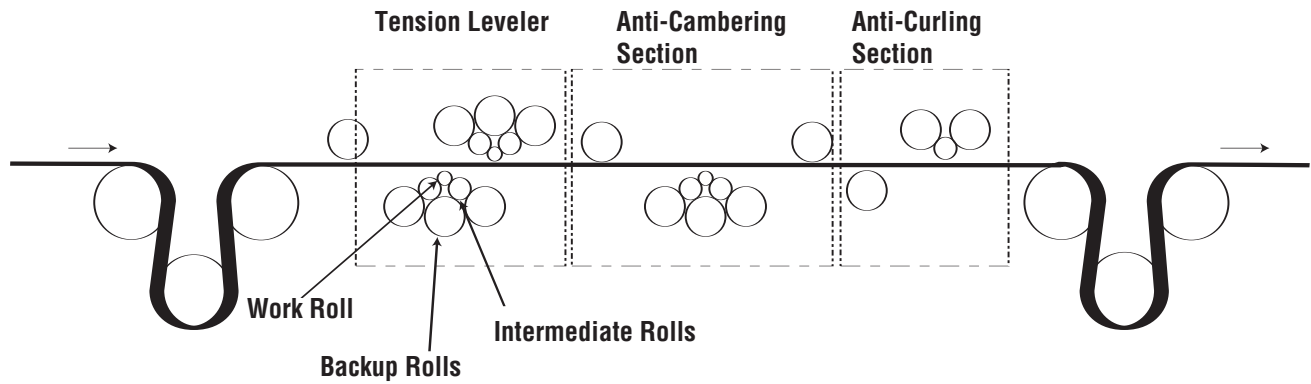

NSK tension leveler roll unit bearings, type UMB, combine high accuracy, low torque and excellent sealing in a variety of maintenance-free units.

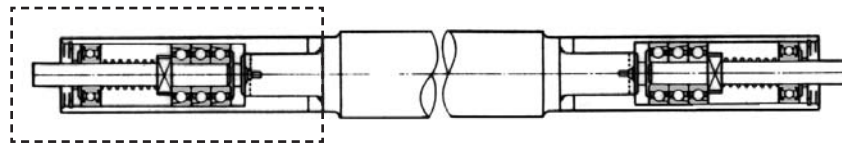

Thrust Blocks for Work Rolls and Intermediate Rolls – An assembly using angular contact ball bearings provides high thrust capacity and an ability to accelerate instantly. Low torque grease and seals provide reliable, maintenance-free operation.

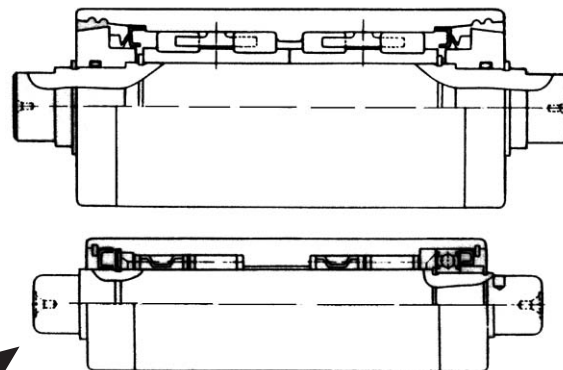

Backup Roll Units – Backup rolls offer high radial load capacity and are matched in sets to assure even support by all rolls. Optional special materials extend roll surface life in wet applications. Life of the assembly can be extended by using NSK regrind service.