

HR-E

MALE ROD ENDS | METAL TO METAL | 3 PIECE

Materials

	HR-E	HR-ECR
BODY	Chromium-Molybdenum Steel Zinc Plated	SUS630 Stainless Steel Passivated
RACE	410 Stainless Steel / Heat Treated	410 Stainless Steel / Heat Treated
BALL	Bearing Steel / Chrome Plated	Bearing Steel / Heat Treated

Description of Types

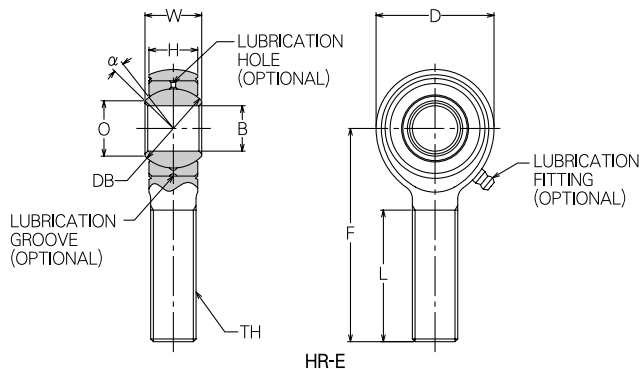
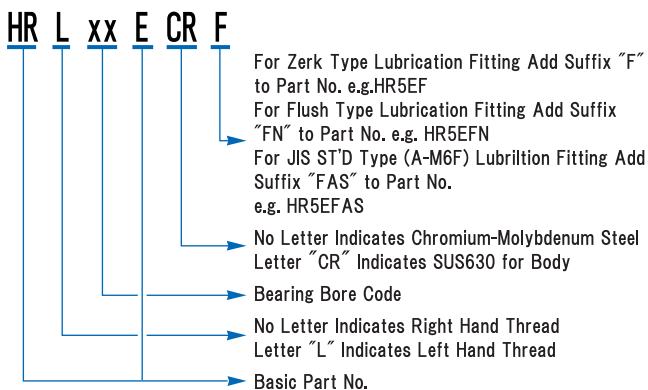

Dimensions in mm

MINEBEA Part No.	φB H7	φD ± 0.5	W 0 - 0.13	H ± 0.13	F ± 0.5	TH JIS Class 2	L ± 0.7	α (deg.)	φ O Ref.	S φ DB Ref.	Static Limit Load kN		Radial Static Ultimate Load kN	Fatigue Load (2) kN	Approx. Weight g
											Radial	Axial (1)			
HR3E	3	16.0	7.0	5.25	30.0	M3 × 0.5	10.0	18	5.2	8.73	3.62	2.94	4.51	0.73	25
HR4E	4	18.0	9.5	7.75	35.0	M4 × 0.7	16.0	16	5.8	11.11	6.27	3.53	7.84	1.27	30
HR5E	5	20.5	11.0	8.75	39.5	M5 × 0.8	22.0	15	7.8	13.49	10.29	5.09	12.84	2.10	35
HR6E	6					M6 × 1.0					14.51		18.14		
HR8E	8	23.0	12.5	8.25	46.0	M8 × 1.25	29.0	14	10.9	15.48	26.77	5.58	33.44	5.54	40
HR10E	10	26.0		10.75	47.0	M10 × 1.5					8		12.2		
HR12E	12	34.0	16.0	13.25	62.0	M12 × 1.75	37.0	10	15.4	22.22	62.46	8.33	78.06	12.94	126
HR14E	14	36.0	17.0	14.25	64.0	M14 × 2.0	38.0	8	18.9	25.40	82.96	9.02	103.65	17.25	140
HR15E	15	38.0	18.0		65.0						11		19.0		
HR16E	16	39.0	19.0	15.25	66.5	M16 × 2.0	39.5	10	19.2	26.99	100.71	9.70	125.81	20.98	195
HR17E	17	41.0	20.0		72.5	M16 × 1.5	42.0	12	20.4	28.58	101.40	10.29	126.70	21.08	220
HR18E	18	43.0		16.30	79.5	M18 × 1.5	46.0	10			120.62	12.16	150.72	25.10	250
HR20E	20	45.0	22.0	19.30	83.0	M20 × 1.5	50.0	13	22.9	31.75	121.30	12.84	151.61	25.20	290
HR22E	22	52.0			86.0	M22 × 1.5	51.0	6	27.1	34.92	156.21	15.10	195.25	32.55	450
HR25E	25	70.0	35.0	25.30	105.0	M24 × 2.0	59.0	15	32.3	47.62	300.08	20.88	375.10	62.56	1150
HR28E	28	75.0			110.0	M27 × 2.0	62.0	14	36.8	50.80	283.70	23.24	354.60	59.13	1500
HR30E	30	78.0	37.0	26.30	120.0	M30 × 2.0	65.0		14	40.4	54.77	271.93	24.81	339.89	56.68

Notes

- (1) Axial load indicates either the smaller value of static load or proof load.
 - (2) Special specification can bare higher fatigue load.
 3. Made to order only.
 4. Radial clearance All Size: 0.051mm MAX
- Please consult MINEBEA for availability of bearings in this series.

Bore size	~ 3	~ 6	~ 10	~ 18	~ 30
H7 Tolerance (μm)	+ 10 0	+ 12 0	+ 15 0	+ 18 0	+ 21 0