

**Masta**<sup>®</sup>  
PRECISION HOUSINGS

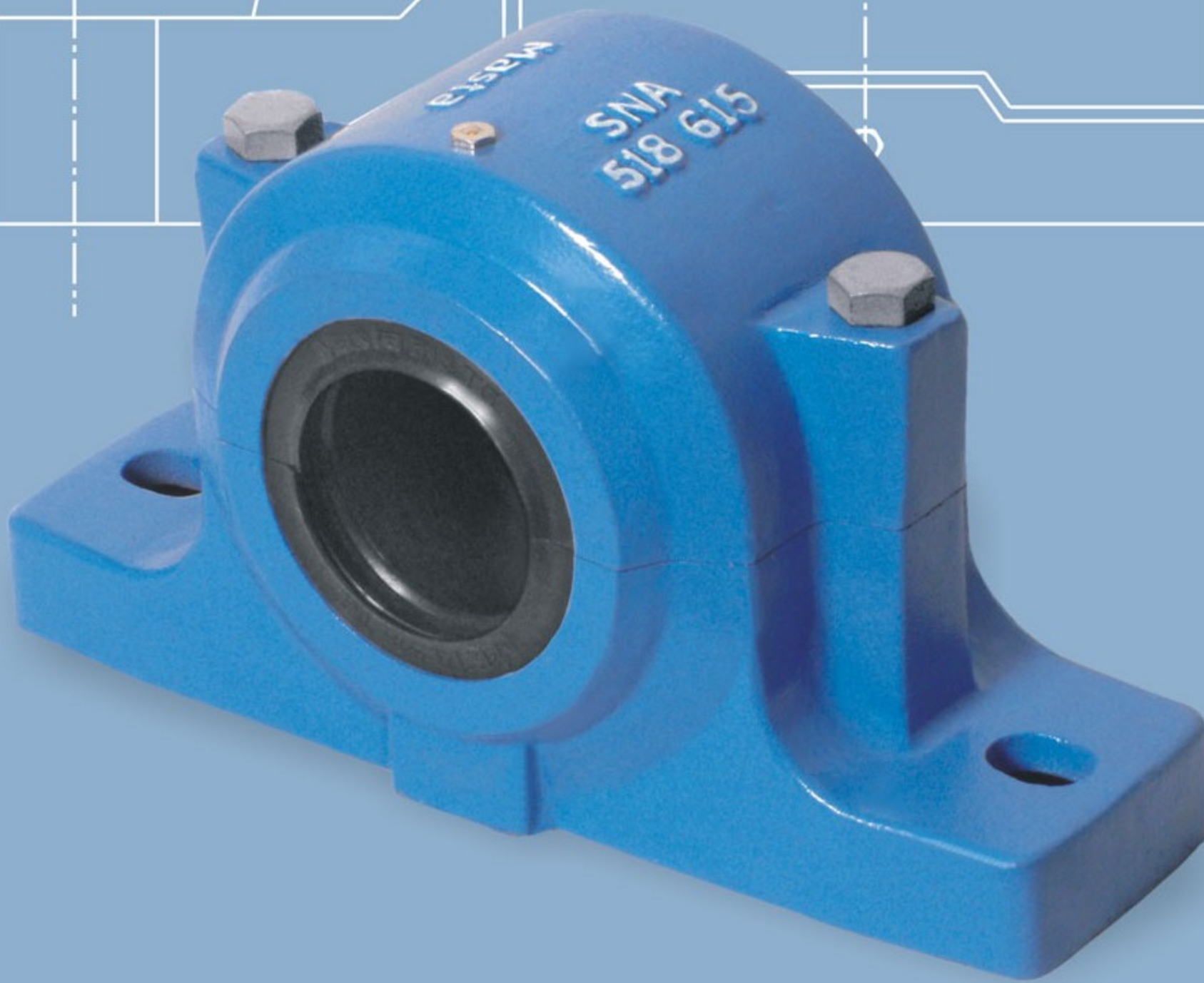
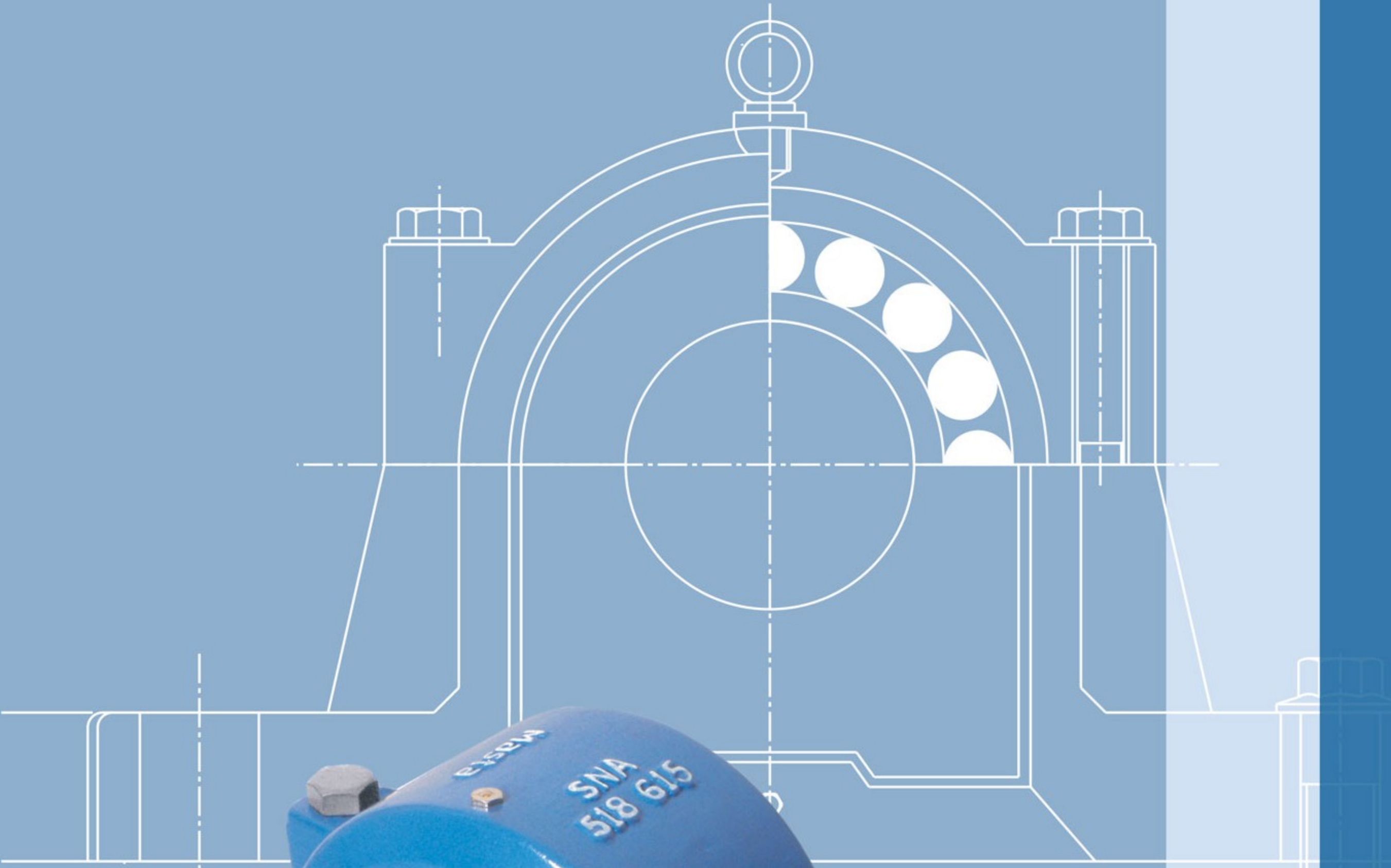

SNA Series

# SNA Series

**Plummer Blocks (Bearing housings)  
Series SNA 500 / 600 for bearings with adapter sleeves**

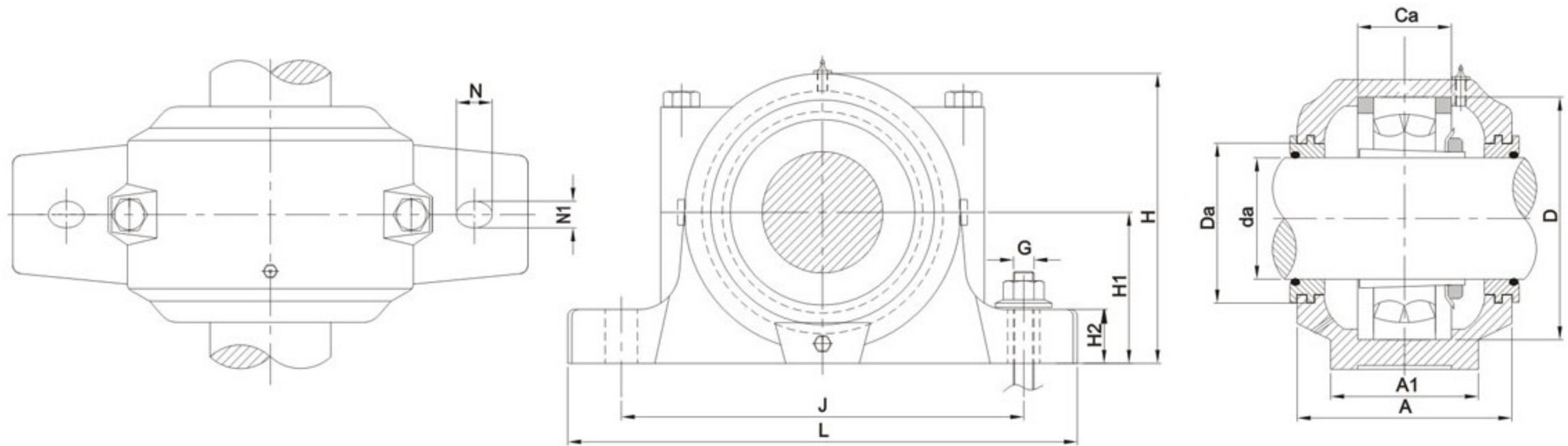

Plummer Block Designation	Shaft dia da mm	DIMENSION IN MM												Approx Weight kg.	Bearing with Adapter Sleeve	Locating Rings	No.																																																				
		A	A1	Da	H	H1	H2	J	L	Ca	N	N1	G																																																								
SNA 505	20	67	46	31.5	71	40	19	130	165	25	20	13	10	1.4	1205 K + H 205	5/52	2																																																				
															2205 K + H 305	7/52	1																																																				
SNA 506	25														77	52	36.5	87	50	22	150	185	32	22	13	10	1.95	1206 K + H 206	8/62	2																																							
																												2206 K + H 306	6/62	2																																							
SNA 605	20																											77	52	36.5	87	50	22	150	185	32	22	13	10	1.95	1305 K + H 305	7.5/62	2																										
																																									2305 K + H 2305	8/62	1																										
SNA 507	30																																								82	52	46.5	92	50	22	150	185	34	20	13	10	2.2	1207 K + H 207	8.5/72	2													
																																																						2207 K + H 307	5.5/72	2													
																																																						22207 CK + H 307	5.5/72	2													
SNA 606	25																																																					82	52	46.5	92	50	22	150	185	34	20	13	10	2.2	1306 K + H 306	7.5/72	2
																																																																			2306 K + H 2306	7/72	1
SNA 508	35																																																																		85	60	51.5
		2208 K + H 308	8/80	2																																																																	
		22208 CK + H 308	8/80	2																																																																	
SNA 607	30	85	60	51.5	106	60	25	170	205	39	20	15	12	2.65	1307 K + H 307	9/80	2																																																				
															2307 K + H 2307	8/80	1																																																				
SNA 509	40														85	60	56.5	109	60	25	170	205	30	20	15	12	2.8	1209 K + H 209	5.5/85	2																																							
																												2209 K + H 309	7/85	1																																							
																												22209 CK + H 309	7/85	1																																							
SNA 510	45																											90	60	62	112	60	25	170	205	41	20	15	12	3.00	1210 K + H 210	10.5/90	2																										
																																									2210 K + H 310	9/90	2																										
																																									22210 CK + H 310	9/90	2																										
SNA 608	35																																								90	60	62	112	60	25	170	205	41	20	15	12	3.00	1308 K + H 308	9/90	2													
																																																						2308 K + H 2308	8/90	1													
																																																						21308 K + H 308	9/90	2													
																																																						22308 CK + H 2308	8/90	1													
SNA 511	50	95	70	67	127	70	28	210	255	44	23	18	16	4.5																																								1211 K + H 211	11.5/100	2													
															2211 K + H 311	9.5/100	2																																																				
															22211 CK + H 311	9.5/100	2																																																				
SNA 609	40														95	70	67	127	70	28	210	255	44	23	18	16	4.5																											1309 K + H 309	9.5/100	2													
																												2309 K + H 2309	8/100	1																																							
																												21309 K + H 309	9.5/100	2																																							
																												22309 CK + H 2309	8/100	1																																							

# SNA 500 & 600 Series

## Plummer Blocks (Bearing housings) Series SNA 500 / 600 for bearings with adapter sleeves

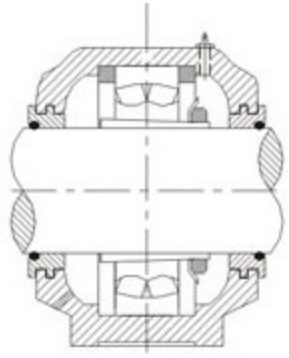

TS Type Design  
Labyrinth Collar

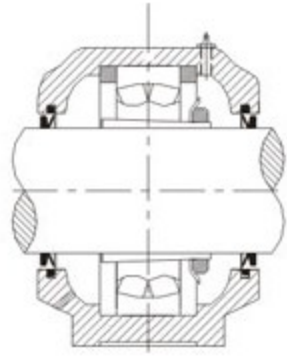

TA Type Design  
V-Ring with Lip Washer

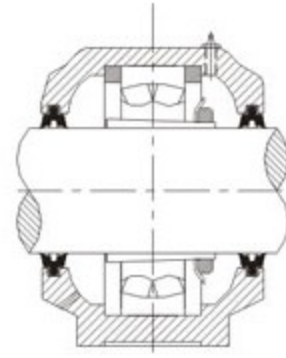

TG Type Design  
Double Lip Seal

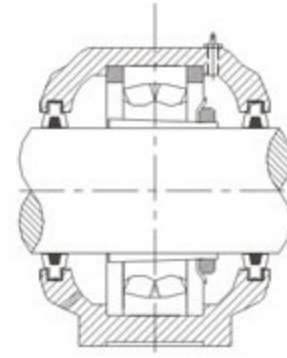

TC Type Design  
Felt Collar

with Locating Ring  
Locating / Fix Type

without Locating Ring  
Floating / Loose Type

\* Plummer Blocks 524 / 620 and above only are Supplied with eye bolt

Plummer Block Designation	Shaft dia da mm	DIMENSION IN MM												Approx Weight kg.	Bearing with Adapter Sleeve	Locating Rings	No.
		A	A1	Da	H	H1	H2	J	L	Ca	N	N1	G				
SNA 512	55	105	70	72	133	70	30	210	255	48	23	18	16	4.9	1212 K + H 212	13/110	2
															2212 K + H 312	10/110	2
															22212 CK+ H 312	10/110	2
SNA 610	45													5.8	1310 K + H 310	10.5/110	2
															2310 K + H 2310	8/110	1
															21310 K + H 310	10.5/110	2
															22310 K + H 2310	8/110	1
SNA 513	60	110	80	77	148	80	30	230	275	51	24	18	16	5.8	1213 K + H 213	14/120	2
															2213 K + H 313	10/120	2
															22213 CK+ H 313	10/120	2
SNA 611	50													6.5	1311 K + H 311	11/120	2
															2311 K + H 2311	8/120	1
															21311 K + H 311	11/120	2
															22311 K + H 2311	8/120	1
SNA 515	65	115	80	87	154	80	30	230	280	56	26	18	16	6.5	1215 K + H 215	15.5/130	2
															2215 K + H 315	12.5/130	2
															22215 CK+ H 315	12.5/130	2
SNA 612	55													9.5	1312 K + H 312	12.5/130	2
															2312 K + H 2312	10/130	1
															21312 CK+ H 312	12.5/130	2
															22312 CK+ H 2312	10/130	1
SNA 516	70	120	90	92.5	175	95	32	260	315	58	29	22	20	9.5	1216 K + H 216	16/140	2
															2216 K + H 316	12.5/140	2
															22216 CK+ H 316	12.5/140	2
SNA 613	60													10.0	1313 K + H 313	12.5/140	2
															2313 K + H 2313	10/140	1
															21313 CK + H 313	12.5/140	2
															22313 CK + H 2313	10/140	1
SNA 517	75	125	90	97.5	181	95	32	260	320	61	30	22	20	10.0	1217 K + H 217	16.5/150	2
															2217 K + H 317	12.5/150	2
															22217 CK+ H 317	12.5/150	2
SNA 518	80	140	100	102.5	192	100	35	290	345	65	27	22	20	12.8	1218 K + H 218	17.5/160	2
															2218 K + H 318	12.5/160	2
															22218 CK+ H 318	12.5/160	2
															23218 CK+ H 2318	12.5/160	1
SNA 615	65													12.8	1315 K + H 315	14/160	2
															2315 K + H 2315	10/160	1
															21315 K + H 315	14/160	2
															22315 K + H 2315	10/160	1

Plummer Blocks (Bearing housings)  
Series SNA 500 / 600 for bearings with adapter sleeves

Plummer Block SNA 524 / 620 and above  
are supplied with eye bolt on cap

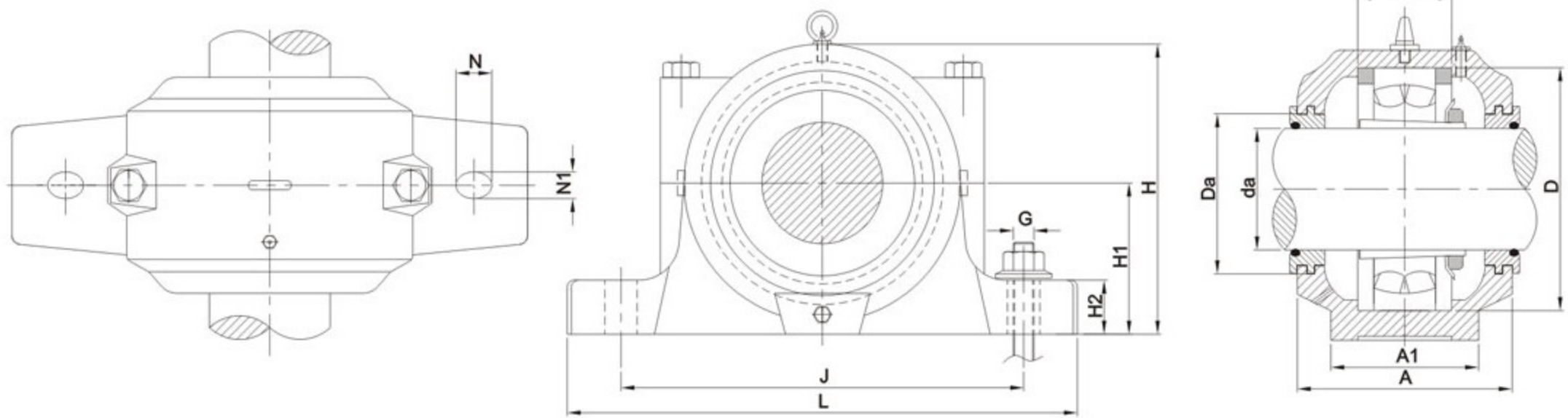

Plummer Block Designation	Shaft dia da mm	DIMENSION IN MM												Approx Weight kg.	Bearing with Adapter Sleeve	Locating Rings	No.
		A	A1	Da	H	H1	H2	J	L	Ca	N	N1	G				
SNA 519	85	145	100	131	209	112	35	290	345	68	27	22	20	14.5	1219 K + H 219	18/170	2
															2219 K + H 319	12.5/170	2
															22219 CK+ H 319	12.5/170	2
SNA 616	70													14.5/170	1316 K + H 316	14.5/170	2
															2316 K + H 2316	10/170	1
															21316 K + H 316	14.5/170	2
															22316 K + H 2316	10/170	1
SNA 520	90	160	110	137.5	215	112	40	320	380	70	32	26	24	17.5	1220 K + H 220	18/180	2
															2220 K + H 320	12/180	2
															22220 CK+ H 320	12/180	2
															23220 CK+ H 2320	9.7/180	1
SNA 617	75													14.5/180	1317 K + H 317	14.5/180	2
															2317 K + H 2317	10/180	1
															21317 K + H 317	14.5/180	2
															22317 K + H 2317	10/180	1
SNA 522	100	175	120	147.5	239	125	45	350	410	80	32	26	24	22	1222 K + H 222	21/200	2
															2222 K + H 322	13.5/200	2
															22222 CK+ H 322	13.5/200	2
															23222 CK+ H 2322	10/200	1
SNA 619	85													25.0	22319 CK+ H 2319	13/200	1
SNA 524	110	185	120	157.5	271	140	45	350	410	86	32	26	24		22224 CK+ H 3124	14/215	2
														23224 CK+ H 2324	10/215	1	
SNA 620	90													33.0	22320 CK+ H 2320	13/215	1
SNA 526	115	190	130	167.5	290	150	50	380	445	90	35	28	24		22226 CK+ H 3126	13/230	2
														23226 CK+ H 2326	10/230	1	
SNA 528	125	205	150	177.5	302	150	50	420	500	98	42	35	30	43.0	22228 CK+ H 3128	15/250	2
															23228 CK+ H 2328	10/250	1
SNA 530	135	220	160	192.5	323	160	60	450	530	106	42	35	30	51.0	22230 CK+ H 3130	16.5/270	2
															23230 CK+ H 2330	10/270	1
SNA 532	140	235	160	202.5	344	170	60	470	550	114	42	35	30	58	22232 CK+ H 3132	17/290	2
															23232 CK+ H 2332	10/290	1

**SSNAD Series  
Plummer Blocks with Drilled Holes in Base**

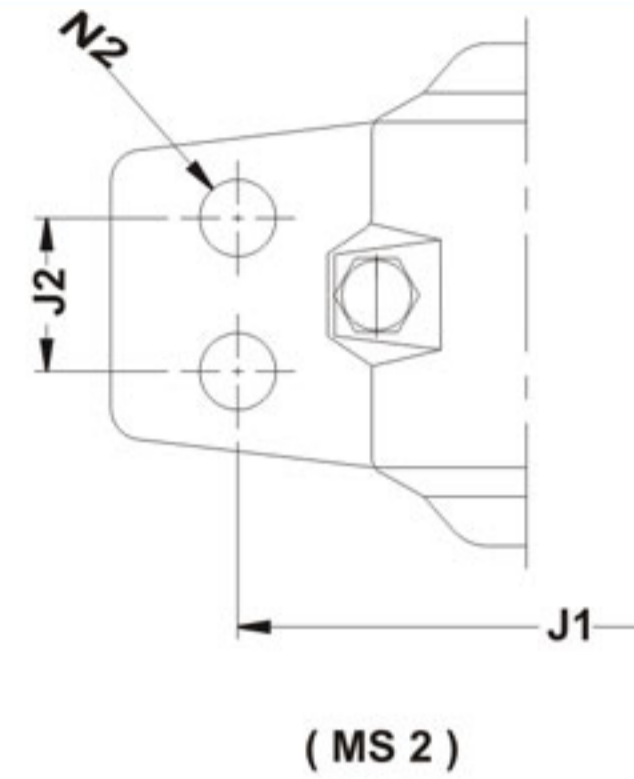
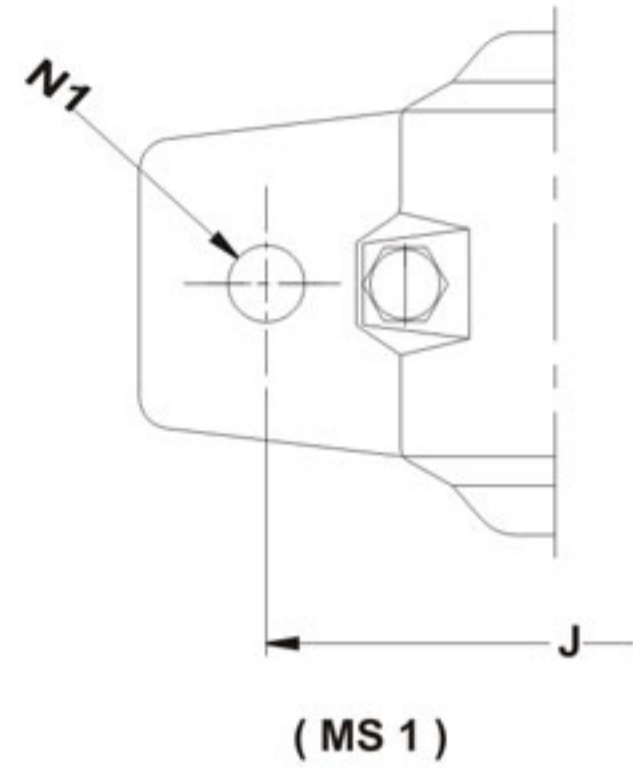

Housing Designation	MS-1			MS-2			
	Dimension for Two Hole Base		Suitable Bolt Size	Dimension For Four Hole Base			Suitable Bolt Size
	J	N1		J1	J2	N2	
SSNAD 511-609	210	18	M 16	200	35	13	M 12
SSNAD 512-610	210	18	M 16	200	35	13	M 12
SSNAD 513-611	230	18	M 16	220	40	13	M 12
SSNAD 515-612	230	18	M 16	220	40	13	M 12
SSNAD 516-613	260	22	M 20	250	50	13	M 12
SSNAD 517-614	260	22	M 20	250	50	13	M 12
SSNAD 518-615	290	22	M 20	280	50	18	M 16
SSNAD 519-616	290	22	M 20	280	50	18	M 16
SSNAD 520-617	320	26	M 24	300	60	18	M 16
SSNAD 522-619	350	26	M 24	320	70	18	M 16
SSNAD 524-620	350	26	M 24	330	70	18	M 16
SSNAD 526	380	28	M 24	370	70	22	M 20
SSNAD 528	420	35	M 30	400	80	26	M 24
SSNAD 530	450	35	M 30	430	90	26	M 24
SSNAD 532	470	35	M 30	450	90	26	M 24

REST OF THE DIMENSIONS SHALL BE AS PER SNA SERIES

"MASTA" SNH series plummer blocks are also horizontally split and are fully interchangeable with those of earlier SN and SNA series plummer blocks.

All features of standard and special shaft seals, interchangeability with 500 and 600 series for bearing with tapered bore and adapter mounting or with (straight) cylindrical bore etc. are available in SHN series plummer blocks also. Its more favorable cross section and improved design have resulted into greater strength as compared to SN or SNA series Plummer Blocks.

SNH plummer blocks have dowel pins at its mating surface to ensure correct assembly of base and cap. The bases and caps are not interchangeable. Like SNA series, the plummer blocks of SNH series are also supplied with standard shaft seals e.g. Felt seals {TC} or V Rings (TA) or V Ring on one end and End Cover on other end (ATA.) Special shaft seals such as Labyrinth seals (TS) or double lip seals (TG), taconite seals (ND) can also be supplied against orders.

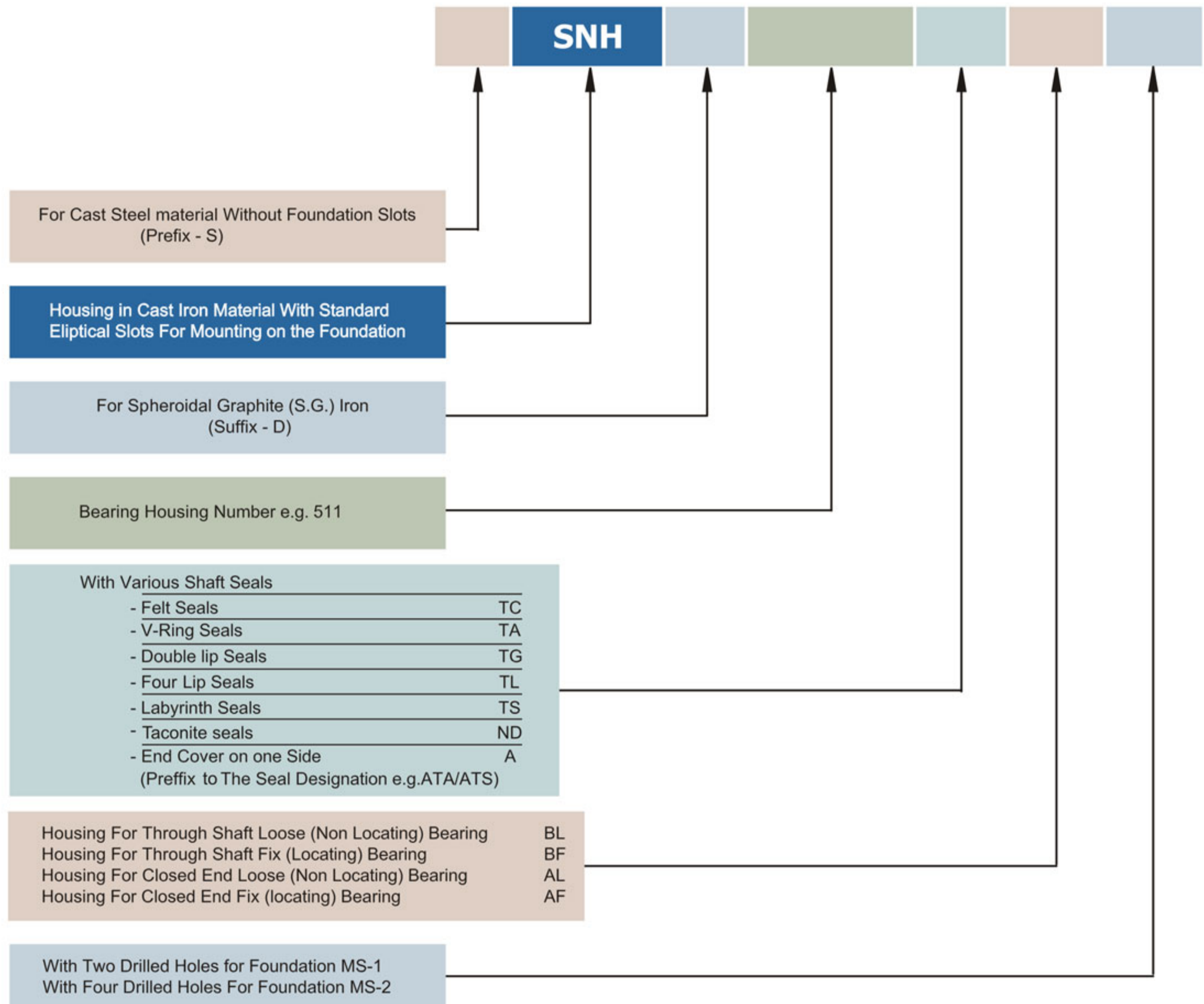

**SNH 511 TS BF**



**S SNH D 515 ATA BL MS-2**

