

Bearings | Link-Belt® Klean-Gard™ Corrosion Resistant
(English-Inch)



Link-Belt® Klean-Gard™ Bearings

Rexnord introduces the ultimate in bearing protection for the food and beverage industry



Two-bolt flange with auxiliary seals



Three-bolt flange with auxiliary seals



Four-bolt flange with auxiliary seals



Pillow block with auxiliary seals

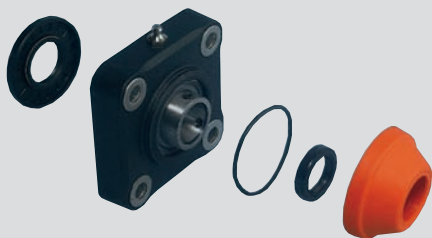

Auxiliary seal arrangement available for field installation if needed

Corrosion resistant fittings for relubrication. Bearing insert factory prelubricated with food-grade grease.

Rugged, reinforced housing material available in Polyamide (black) or Polypropylene (white) for extreme corrosion resistance.

Inch or metric shaft sizes available.

Both open and closed auxiliary safety caps fit tightly to the machined housing and are sealed with heavy duty O-rings.

Alignable, high capacity, stainless steel or black oxide ball bearing mounted with setscrews to the shaft. Integral bearing lip seals.

Front and rear auxiliary rotary shaft seals provided with spring loaded double lip seal to guard critical bearing components and prevent conveyor contamination.

AISI 316 stainless steel spacer bushing and washer for trouble-free, positive mounting.



Klean-Gard Bearings are furnished with Microban® antimicrobial product protection.

Microban is formulated to inhibit the growth of bacteria, mold and mildew that may cause discoloration, odor or degradation.

Always maintain good hygiene; proper cleaning procedures are still required.

Microban is a registered trademark of the Microban Products Company.

Interchangeable with cast iron units.

Beverage bearing configuration available upon request, add the prefix "W."

Corrosion Resistant Stainless Steel

Klean-Gard™ Flanged Units KFX-SS200, KLFX-SS200

Reinforced Polyamide or Polypropylene Housing
2-Bolt Mounting
Alignable
Set Screw Locking
Stainless Steel Bearing Insert
Stainless Steel Bushing and Washers
Prelubricated with Mobile FM102 Food-Grade Grease
Relubricatable

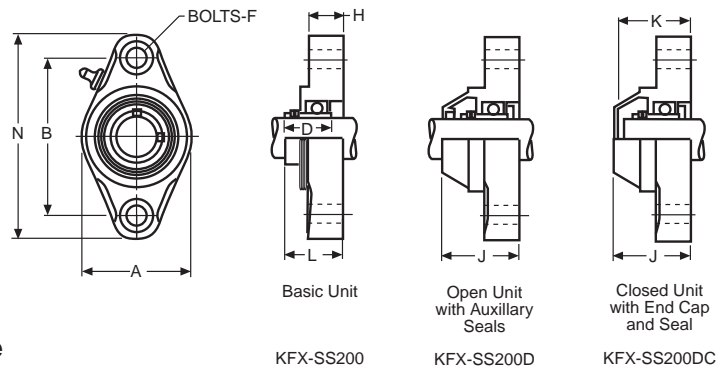

Dimensions (mm/inches)

Shaft Diameter		Flanged Unit Number		A	B	D	F Bolts	H	J	K	L	N
mm	inches	Polyamide	Polypropylene▲									
20	¾	KFX-SS212	KLFX-SS212	27 ¹ / ₁₆	3.543	1 ⅞	¾	5 ¹ / ₆₄	1 13 ¹ / ₁₆	1 11 ¹ / ₁₆	1 23 ¹ / ₆₄	4 9 ¹ / ₁₆
		KFX-SS2M20	KLFX-SS2M20	62	90	28.58	10	20	46	43	34.3	116
25	1	KFX-SS216	KLFX-SS216	2 13 ¹ / ₁₆	3.898	1 3 ¹ / ₁₆	¾	7 ¹ / ₈	1 61 ¹ / ₆₄	1 7 ¹ / ₈	1 15 ¹ / ₃₂	5 1 ¹ / ₈
		KFX-SS2M25	KLFX-SS2M25	71	99	30.17	10	22.5	49.5	47.5	37.3	130
30	1 3 ¹ / ₁₆	KFX-SS219	KLFX-SS219	3 11 ¹ / ₃₂	4.606	1 11 ¹ / ₃₂	¾	1 1 ¹ / ₆₄	2 11 ¹ / ₆₄	2 3 ¹ / ₃₂	1 3 ¹ / ₄	5 53 ¹ / ₆₄
	1 ¼	KFX-SS2E20	KLFX-SS2E20									
		KFX-SS2M30	KLFX-SS2M30	85	117	34.13	10	26	55	53	44.2	148
35	1 ¼	KFX-SS220	KLFX-SS220	3 21 ¹ / ₃₂	5.118	1 9 ¹ / ₁₆	¾	1 1 ¹ / ₆₄	2 21 ¹ / ₆₄	2 ¼	1 7 ¹ / ₈	6 3 ¹ / ₈
	1 3 ¹ / ₈	KFX-SS222	KLFX-SS222									
	1 7 ¹ / ₁₆	KFX-SS223	KLFX-SS223									
		KFX-SS2M35	KLFX-SS2M35	93	130	39.67	10	26	59	57	47.7	162
40	1 ½	KFX-SS224	KLFX-SS224	4 1 ¹ / ₆₄	5.672	1 11 ¹ / ₁₆	¾	1 1 ¹ / ₁₆	2 37 ¹ / ₆₄	2 15 ¹ / ₃₂	2 1 ¹ / ₁₆	6 59 ¹ / ₆₄
		KFX-SS2M40	KLFX-SS2M40	102	144	42.87	10	30	65.5	62.5	52.4	176

See footnotes and Housing Load Ratings on inside back cover.

Corrosion Resistant Black Oxide

Klean-Gard™ Flanged Units KFX-S200, KLFX-S200

Reinforced Polyamide or Polypropylene Housing
2-Bolt Mounting
Alignable
Set Screw Locking
Stainless Steel Bushing and Washers
Prelubricated with Chevron FM2 Food-Grade Grease
Relubricatable
Inner and Outer Rings with Black Oxide Coating

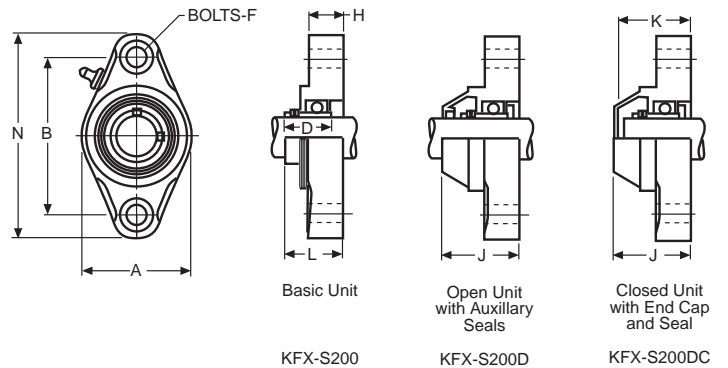

Dimensions (mm/inches)

Shaft Diameter		Flanged Unit Number		A	B	D	F Bolts	H	J	K	L	N
mm	inches	Polyamide	Polypropylene▲									
20	¾	KFX-S212	KLFX-S212	27 ¹ / ₁₆	3.543	1 ⅞	¾	5 ¹ / ₆₄	1 13 ¹ / ₁₆	1 11 ¹ / ₁₆	1 23 ¹ / ₆₄	4 9 ¹ / ₁₆
		KFX-S2M20	KLFX-S2M20	62	90	28.58	10	20	46	43	34.3	116
25	1	KFX-S216	KLFX-S216	2 13 ¹ / ₁₆	3.898	1 11 ¹ / ₆₄	¾	7 ¹ / ₈	1 61 ¹ / ₆₄	1 7 ¹ / ₈	1 15 ¹ / ₃₂	5 1 ¹ / ₈
		KFX-S2M25	KLFX-S2M25	71	99	29.77	10	22.5	49.5	47.5	37.3	130
30	1 3 ¹ / ₁₆	KFX-S219	KLFX-S219	3 11 ¹ / ₃₂	4.606	1 11 ¹ / ₃₂	¾	1 1 ¹ / ₆₄	2 11 ¹ / ₆₄	2 3 ¹ / ₃₂	1 3 ¹ / ₄	5 53 ¹ / ₆₄
	1 ¼	KFX-S2E20	KLFX-S2E20									
		KFX-S2M30	KLFX-S2M30	85	117	34.13	10	26	55	53	44.2	148
35	1 ¼	KFX-S220	KLFX-S220	3 21 ¹ / ₃₂	5.118	1 9 ¹ / ₁₆	¾	1 1 ¹ / ₆₄	2 21 ¹ / ₆₄	2 ¼	1 7 ¹ / ₈	6 3 ¹ / ₈
	1 3 ¹ / ₈	KFX-S222	KLFX-S222									
	1 7 ¹ / ₁₆	KFX-S223	KLFX-S223									
		KFX-S2M35	KLFX-S2M35	93	130	39.67	10	26	59	57	47.7	162
40	1 ½	KFX-S224	KLFX-S224	4 1 ¹ / ₆₄	5.672	1 21 ¹ / ₃₂	¾	1 1 ¹ / ₁₆	2 37 ¹ / ₆₄	2 15 ¹ / ₃₂	2 1 ¹ / ₁₆	6 59 ¹ / ₆₄
		KFX-S2M40	KLFX-S2M40	102	144	42.06	10	30	65.5	62.5	52.4	176

See footnotes and Housing Load Ratings on inside back cover.

Corrosion Resistant Stainless Steel

Klean-Gard™ Flanged Units KFB-SS200, KLFB-SS200

Reinforced Polyamide or Polypropylene Housing
3-Bolt Mounting
Alignable
Set Screw Locking
Stainless Steel Bearing Insert
Stainless Steel Bushing and Washers
Prelubricated with Mobile FM102 Food-Grade Grease
Relubricatable

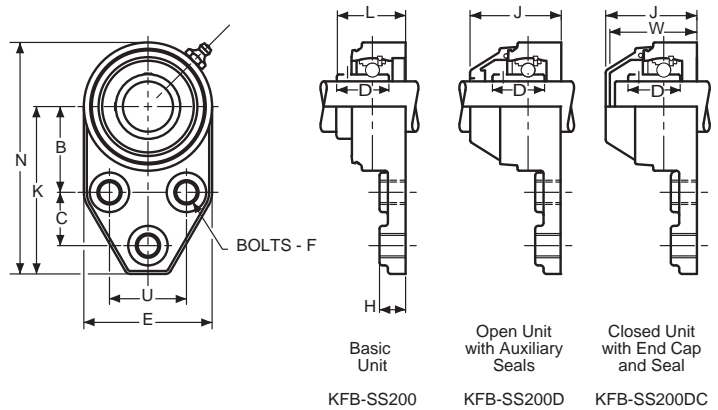

Dimensions (mm/inches)

Shaft Diameter		Flanged Unit Number		B	C	D	E	F	H	J	K	L	N	U	W												
mm	inches	Polyamide	Polypropylene▲	Bolts																							
25	1	KFB-SS216	KLFB-SS216	1 ³ / ₁₆	1 ¹ / ₈	1 ³ / ₁₆	2 ²³ / ₃₂	3 ³ / ₈	9 ¹ / ₁₆	2 ¹ / ₆₄	3 ¹⁷ / ₃₂	1 ¹⁷ / ₃₂	4 ⁵⁷ / ₆₄	1 ⁵ / ₈	1 ¹⁵ / ₁₆												
		KFB-SS2M25	KLFB-SS2M25	46.0	28.58	30.17	69	10	14.0	51.2	89.8	38.9	124	41.28	49.2												
30	1 ³ / ₁₆	KFB-SS219	KLFB-SS219	2 ¹ / ₁₆	1 ¹ / ₄	1 ¹¹ / ₃₂	3 ¹ / ₆₄	3 ³ / ₈	9 ¹ / ₁₆	2 ¹ / ₆₄	3 ⁵⁵ / ₆₄	1 ³ / ₄	5 ¹⁵ / ₃₂	1 ⁷ / ₈	2 ³ / ₃₂												
	1 ¹ / ₄	KFB-SS2E20	KLFB-SS2E20													52.4	31.70	34.13	81	10	14.0	55.2	97.9	44.2	139	47.60	53.2
	KFB-SS2M30	KLFB-SS2M30																									
35	1 ¹ / ₄	KFB-SS220	KLFB-SS220	2 ³ / ₈	1 ¹ / ₄	1 ¹ / ₁₆	3 ¹ / ₁₆	7 ¹ / ₁₆	9 ¹ / ₁₆	2 ² / ₆₄	4 ¹⁵ / ₆₄	1 ⁷ / ₈	6 ⁵ / ₆₄	2	2 ¹ / ₄												
	1 ³ / ₈	KFB-SS222	KLFB-SS222													60.3	31.70	39.67	94	12	14.0	59.1	107.6	47.7	154	50.80	57.2
	1 ⁷ / ₁₆	KFB-SS223	KLFB-SS223																								
KFB-SS2M35	KLFB-SS2M35																										

See footnotes and Housing Load Ratings on inside back cover.

Corrosion Resistant Black Oxide

Klean-Gard™ Flanged Units KFB-S200, KLFB-S200

Reinforced Polyamide or Polypropylene Housing
3-Bolt Mounting
Alignable
Set Screw Locking
Stainless Steel Bushing and Washers
Prelubricated with Chevron FM2 Food-Grade Grease
Relubricatable
Inner and Outer Rings with Black Oxide Coating

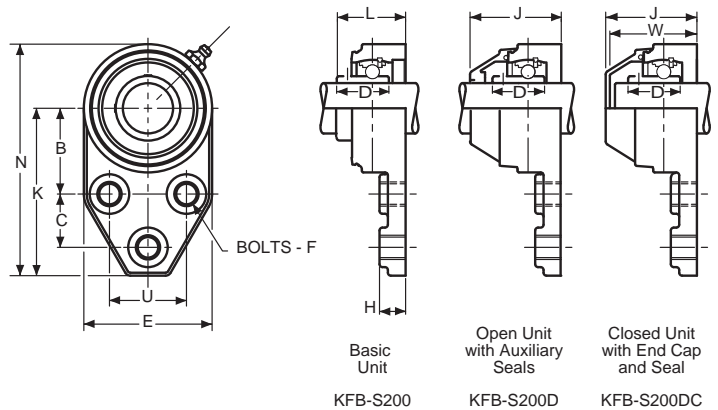

Dimensions (mm/inches)

Shaft Diameter		Flanged Unit Number		B	C	D	E	F	H	J	K	L	N	U	W												
mm	inches	Polyamide	Polypropylene▲	Bolts																							
25	1	KFB-S216	KLFB-S216	1 ³ / ₁₆	1 ¹ / ₈	1 ¹¹ / ₆₄	2 ²³ / ₃₂	3 ³ / ₈	9 ¹ / ₁₆	2 ¹ / ₆₄	3 ¹⁷ / ₃₂	1 ¹⁷ / ₃₂	4 ⁵⁷ / ₆₄	1 ⁵ / ₈	1 ¹⁵ / ₁₆												
		KFB-S2M25	KLFB-S2M25	46.0	28.58	29.77	69	10	14.0	51.2	89.8	38.9	124	41.28	49.2												
30	1 ³ / ₁₆	KFB-S219	KLFB-S219	2 ¹ / ₁₆	1 ¹ / ₄	1 ¹¹ / ₃₂	3 ¹ / ₆₄	3 ³ / ₈	9 ¹ / ₁₆	2 ¹ / ₆₄	3 ⁵⁵ / ₆₄	1 ³ / ₄	5 ¹⁵ / ₃₂	1 ⁷ / ₈	2 ³ / ₃₂												
	1 ¹ / ₄	KFB-S2E20	KLFB-S2E20													52.4	31.70	34.13	81	10	14.0	55.2	97.9	44.2	139	47.60	53.2
	KFB-S2M30	KLFB-S2M30																									
35	1 ¹ / ₄	KFB-S220	KLFB-S220	2 ³ / ₈	1 ¹ / ₄	1 ¹ / ₁₆	3 ¹ / ₁₆	7 ¹ / ₁₆	9 ¹ / ₁₆	2 ² / ₆₄	4 ¹⁵ / ₆₄	1 ⁷ / ₈	6 ⁵ / ₆₄	2	2 ¹ / ₄												
	1 ³ / ₈	KFB-S222	KLFB-S222													60.3	31.70	39.67	94	12	14.0	59.1	107.6	47.7	154	50.80	57.2
	1 ⁷ / ₁₆	KFB-S223	KLFB-S223																								
KFB-S2M35	KLFB-S2M35																										

See footnotes and Housing Load Ratings on inside back cover.

Corrosion Resistant Stainless Steel

Klean-Gard™ Flanged Units KF-SS200, KLF-SS200

Reinforced Polyamide or Polypropylene Housing
4-Bolt Mounting
Alignable
Set Screw Locking
Stainless Steel Bearing Insert
Stainless Steel Bushing and Washers
Prelubricated with Mobile FM102 Food-Grade Grease
Relubricatable

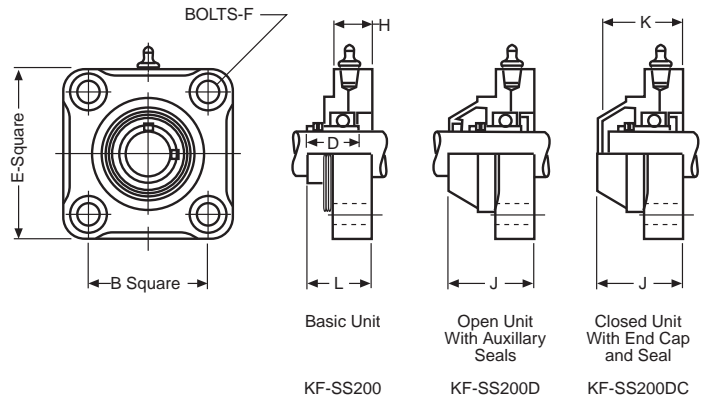

Dimensions (mm/inches)

Shaft Diameter		Flanged Unit Number		B	D	E	F	H	J	K	L
mm	inches	Polyamide	Polypropylene▲				Bolts				
25	1	KF-SS216	KLF-SS216	2.756	13/16	355/64	3/8	7/8	161/64	17/8	115/32
		KF-SS2M25	KLF-SS2M25	70	30.17	98	10	22.5	49.5	47.5	37.3
30	13/16	KF-SS219	KLF-SS219	3.268	111/32	421/64	3/8	11/64	211/64	23/32	13/4
	11/4	KF-SS2E20	KLF-SS2E20								
		KF-SS2M30	KLF-SS2M30	83	34.13	110	10	26	55	53	44.2
35	11/4	KF-SS220	KLF-SS220	3.622	19/16	423/32	3/8	11/64	221/64	21/4	17/8
	13/8	KF-SS222	KLF-SS222								
	17/16	KF-SS223	KLF-SS223								
	KF-SS2M35	KLF-SS2M35	92	39.67	120	10	26	59	57	47.7	
40	11/2	KF-SS224	KLF-SS224	4.016	111/16	53/32	3/8	13/16	237/64	219/32	21/16
		KF-SS2M40	KLF-SS2M40	102	42.87	131	10	30	65.5	62.5	52.4

See footnotes and Housing Load Ratings on inside back cover.

Corrosion Resistant Black Oxide

Klean-Gard™ Flanged Units KF-S200, KLF-S200

Reinforced Polyamide or Polypropylene Housing
4-Bolt Mounting
Alignable
Set Screw Locking
Stainless Steel Bushing and Washers
Prelubricated with Chevron FM2 Food-Grade Grease
Relubricatable
Inner and Outer Rings with Black Oxide Coating

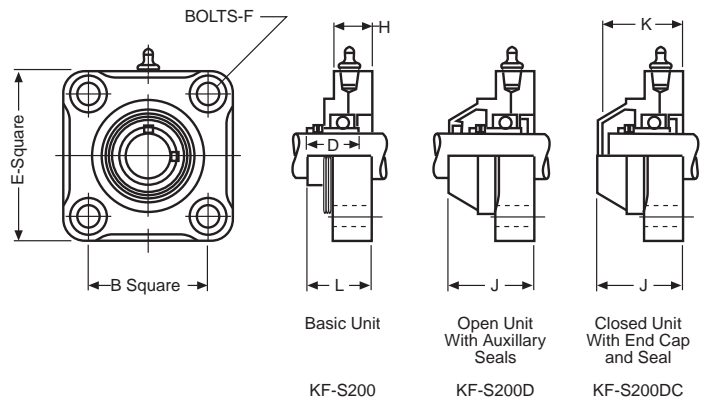

Dimensions (mm/inches)

Shaft Diameter		Flanged Unit Number		B	D	E	F	H	J	K	L
mm	inches	Polyamide	Polypropylene▲				Bolts				
25	1	KF-S216	KLF-S216	2.756	111/64	355/64	3/8	7/8	161/64	17/8	115/32
		KF-S2M25	KLF-S2M25	70	29.77	98	10	22.5	49.5	47.5	37.3
30	13/16	KF-S219	KLF-S219	3.268	111/32	421/64	3/8	11/64	211/64	23/32	13/4
	11/4	KF-S2E20	KLF-S2E20								
		KF-S2M30	KLF-S2M30	83	34.13	110	10	26	55	53	44.2
35	11/4	KF-S220	KLF-S220	3.622	19/16	423/32	3/8	11/64	221/64	21/4	17/8
	13/8	KF-S222	KLF-S222								
	17/16	KF-S223	KLF-S223								
	KF-S2M35	KLF-S2M35	92	39.67	120	10	26	59	57	47.7	
40	11/2	KF-S224	KLF-S224	4.016	121/32	53/32	3/8	13/16	237/64	219/32	21/16
		KF-S2M40	KLF-S2M40	102	42.06	131	10	30	65.5	62.5	52.4

See footnotes and Housing Load Ratings on inside back cover.

Corrosion Resistant Stainless Steel

Klean-Gard™ Pillow Block KP-SS200, KLP-SS200

Reinforced Polyamide or Polypropylene Housing
Alignable
Set Screw Locking
Stainless Steel Bearing Insert
Stainless Steel Bushing and Washers
Prelubricated with Mobile FM102 Food-Grade Grease
Relubricatable

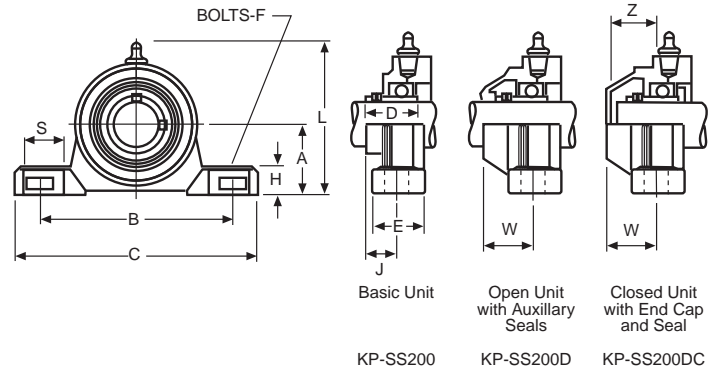

Dimensions (mm/inches)

Shaft Diameter		Flanged Unit Number		A	B	C	D	E	F	H	J	L	S	W	Z
mm	inches	Polyamide	Polypropylene▲	Bolts											
20	¾	KP-SS212	KLP-SS212	1 ¹⁵ / ₁₆	3 ²⁵ / ₃₂	5 ¹ / ₃₂	1 ¹ / ₈	1 ³ / ₁₆	¾	4 ³ / ₆₄	¾	3 ¹ / ₃₂	7 ⁷ / ₈	17 ¹⁷ / ₃₂	1 ¹ / ₈
		KP-SS2M20	KLP-SS2M20	33.3	96	128	28.58	30	10	17	19	77	22	30.8	28.8
25	1	KP-SS216	KLP-SS216	1 ⁷ / ₁₆	4 ¹¹ / ₆₄	5 ³¹ / ₆₄	1 ³ / ₁₆	1 ²³ / ₆₄	¾	4 ³ / ₆₄	1 ³ / ₁₆	3 ¹¹ / ₃₂	7 ⁷ / ₈	19 ¹⁹ / ₃₂	1 ¹³ / ₆₄
		KP-SS2M25	KLP-SS2M25	36.5	106.0	140.0	30.17	34.5	10	17	20.6	85	22.0	32.7	30.7
30	1 ³ / ₁₆	KP-SS219	KLP-SS219	1 ¹¹ / ₁₆	4 ⁴⁹ / ₆₄	6 ²⁷ / ₆₄	1 ¹¹ / ₃₂	1 ²⁷ / ₆₄	½	2 ⁵ / ₃₂	6 ¹ / ₆₄	3 ⁵⁵ / ₆₄	1 ⁵ / ₁₆	1 ³ / ₈	1 ¹⁹ / ₆₄
	1 ¹ / ₄	KP-SS2E20	KLP-SS2E20	42.9	121.0	163.0	34.13	36	12	20	24.2	98	24.0	35	33
	KP-SS2M30	KLP-SS2M30													
35	1 ¹ / ₄	KP-SS220	KLP-SS220	1 ⁷ / ₈	4 ³¹ / ₃₂	6 ³⁷ / ₆₄	1 ⁹ / ₁₆	1 ³³ / ₆₄	½	2 ⁵ / ₃₂	1 ⁷ / ₆₄	4 ¹ / ₄	1 ⁵ / ₁₆	1 ⁹ / ₁₆	1 ¹⁵ / ₃₂
	1 ³ / ₈	KP-SS222	KLP-SS222	47.6	126.0	167.0	39.67	38.6	12	20	28.2	108	24.0	39.5	37.5
	1 ⁷ / ₁₆	KP-SS223	KLP-SS223												
40	1 ¹ / ₂	KP-SS224	KLP-SS224	2	5 ¹¹ / ₃₂	7 ⁹ / ₃₂	1 ¹¹ / ₁₆	1 ³³ / ₆₄	½	2 ⁵ / ₃₂	1 ¹³ / ₆₄	4 ¹³ / ₃₂	1 ⁵ / ₁₆	1 ⁴¹ / ₆₄	1 ⁹ / ₁₆
		KP-SS2M40	KLP-SS2M40	50.8	136	185	42.87	38.6	12	20	30.6	112	24	41.6	39.6

See footnotes and Housing Load Ratings on inside back cover.

Corrosion Resistant Black Oxide

Klean-Gard™ Pillow Block KP-S200, KLP-S200

Reinforced Polyamide or Polypropylene Housing
Alignable
Set Screw Locking
Stainless Steel Bushing and Washers
Prelubricated with Chevron FM2 Food-Grade Grease
Relubricatable
Inner and Outer Rings with Black Oxide Coating

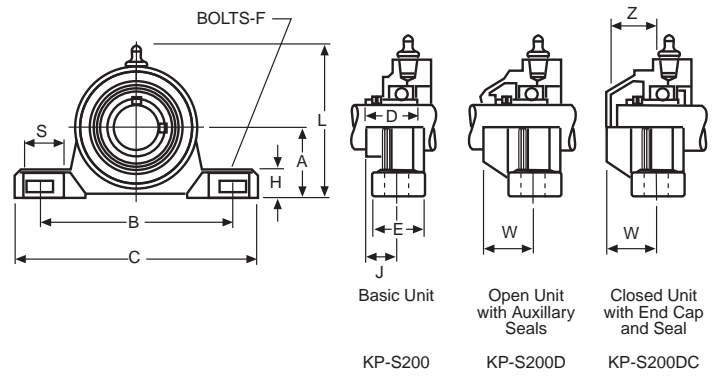

Dimensions (mm/inches)

Shaft Diameter		Flanged Unit Number		A	B	C	D	E	F	H	J	L	S	W	Z
mm	inches	Polyamide	Polypropylene▲	Bolts											
20	¾	KP-S212	KLP-S212	1 ¹⁵ / ₁₆	3 ²⁵ / ₃₂	5 ¹ / ₃₂	1 ¹ / ₈	1 ³ / ₁₆	¾	4 ³ / ₆₄	¾	3 ¹ / ₃₂	7 ⁷ / ₈	17 ¹⁷ / ₃₂	1 ¹ / ₈
		KP-S2M20	KLP-S2M20	33.3	96	128	28.58	30	10	17	19	77	22	30.8	28.8
25	1	KP-S216	KLP-S216	1 ⁷ / ₁₆	4 ¹¹ / ₆₄	5 ³¹ / ₆₄	1 ¹ / ₈	1 ²³ / ₆₄	¾	4 ³ / ₆₄	1 ³ / ₁₆	3 ¹¹ / ₃₂	7 ⁷ / ₈	19 ¹⁹ / ₃₂	1 ¹³ / ₆₄
		KP-S2M25	KLP-S2M25	36.5	106.0	140.0	29.77	34.5	10	17	20.6	85	22.0	32.7	30.7
30	1 ³ / ₁₆	KP-S219	KLP-S219	1 ¹¹ / ₁₆	4 ⁴⁹ / ₆₄	6 ²⁷ / ₆₄	1 ¹¹ / ₃₂	1 ²⁷ / ₆₄	½	2 ⁵ / ₃₂	6 ¹ / ₆₄	3 ⁵⁵ / ₆₄	1 ⁵ / ₁₆	1 ³ / ₈	1 ¹⁹ / ₆₄
	1 ¹ / ₄	KP-S2E20	KLP-S2E20	42.9	121.0	163.0	34.13	36	12	20	24.2	98	24.0	35	33
	KP-S2M30	KLP-S2M30													
35	1 ¹ / ₄	KP-S220	KLP-S220	1 ⁷ / ₈	4 ³¹ / ₃₂	6 ³⁷ / ₆₄	1 ⁹ / ₁₆	1 ³³ / ₆₄	½	2 ⁵ / ₃₂	1 ⁷ / ₆₄	4 ¹ / ₄	1 ⁵ / ₁₆	1 ⁹ / ₁₆	1 ¹⁵ / ₃₂
	1 ³ / ₈	KP-S222	KLP-S222	47.6	126.0	167.0	39.67	38.6	12	20	28.2	108	24.0	39.5	37.5
	1 ⁷ / ₁₆	KP-S223	KLP-S223												
40	1 ¹ / ₂	KP-S224	KLP-S224	2	5 ¹¹ / ₃₂	7 ⁹ / ₃₂	1 ²¹ / ₃₂	1 ³³ / ₆₄	½	2 ⁵ / ₃₂	1 ¹³ / ₆₄	4 ¹³ / ₃₂	1 ⁵ / ₁₆	1 ⁴¹ / ₆₄	1 ⁹ / ₁₆
		KP-S2M40	KLP-S2M40	50.8	136	185	42.06	38.6	12	20	30.6	112	24	41.6	39.6

See footnotes and Housing Load Ratings on inside back cover.

Shaft Size in-mm	BEARING LOAD RATINGS*		MAXIMUM RECOMMENDED EQUIVALENT RADIAL LOAD*	MAXIMUM RECOMMENDED AXIAL LOAD (1)
	Dynamic C	Static Co	P _E	F _a
¾" 20mm	2,230 lb 9,920 N	1,500 lb 6,670 N	332 lb 1,475 N	330 lb 1,468 N
1" 25mm	2,420 lb 10,800 N	1,760 lb 7,030 N	365 lb 1,622 N	330 lb 1,468 N
1⅜", 1¼" 30mm	3,370 lb 1,500 N	2,590 lb 11,300 N	507 lb 2,254 N	330 lb 1,468 N
1¼", 1⅜", 17/16" 35mm	4,430 lb 19,700 N	3,440 lb 15,300 N	670 lb 2,982 N	500 lb 2,224 N
1½" 40mm	5,030 lb 22,400 N	4,010 lb 17,800 N	846 lb 3,765 N	500 lb 2,224 N

WHEN ORDERING, PLEASE SPECIFY HOUSING MATERIAL:



POLYAMIDE HOUSING (BLACK)



POLYPROPYLENE HOUSING (WHITE)

* For equivalent radial load and bearing life calculations refer to Link-Belt® bearing catalog, section B, pages 9 thru 12. If actual bearing load exceeds maximum recommended equivalent radial load or if impact loading will occur, consult Rexnord. Housing should not be used under tension loads. For this reason, pillow blocks are designed to withstand loads directed into the base. Polyamide and Polypropylene housing strength exceeds maximum recommended equivalent radial load. (1) Value based on set screw holding capacity for properly tightened set screws. These values may be used in design, as a safety factor has been applied.

Nomenclature

Klean-Gard Units

Food Grade Grease

Setscrew Locking Feature

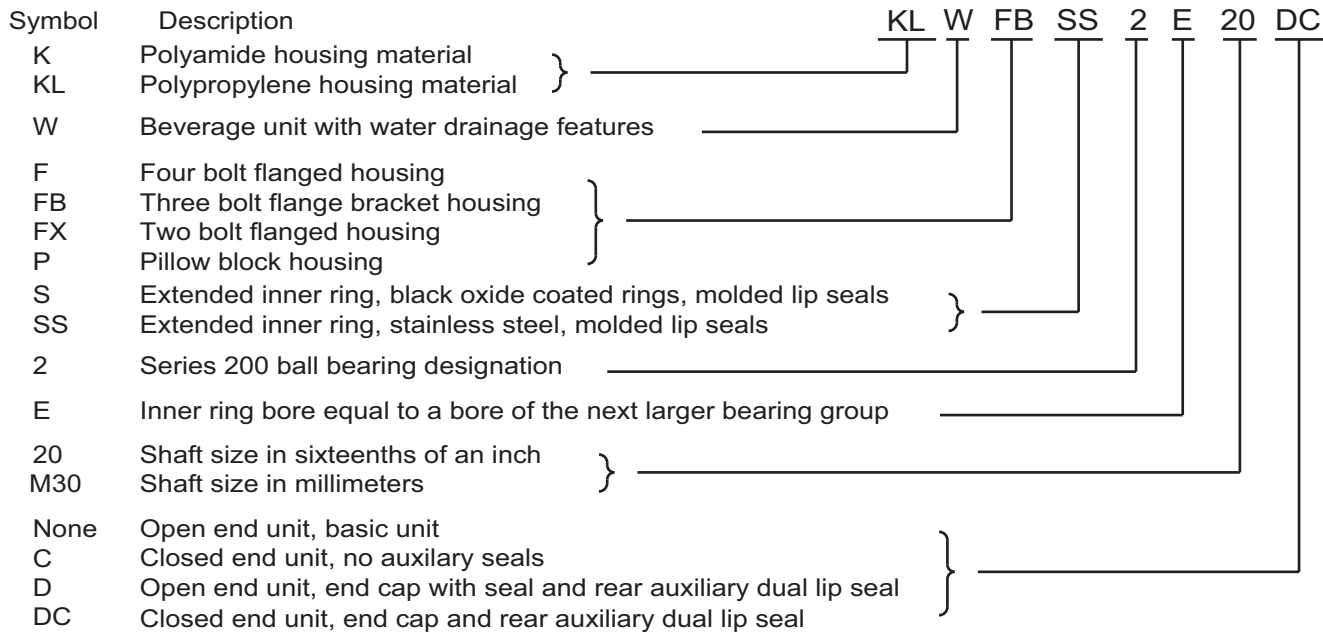

Bold face items are normally available from stock; please consult for availability of non-stock items. Lubrication fitting tap size, Rp ⅜ parallel thread per ISO 7/1 latest revision. **Note:** ⅜" PT external thread will not fit.

▲ Furnished with Viton seals and O-ring and AISI 316 stainless steel bushings and washers.

Link-Belt Bearing Catalog, Document #3000, Selection guide, pages B-9, B-10. Load ratings, pages B-11, B-12. Additional information, pages B-76.

Polyamide and Polypropylene chemical resistance table available on Rexnord website at www.rexnord.com.

World Class Customer Service

For more than 100 years, the dedicated people of Rexnord have delivered excellence in quality and service to our customers around the globe. Rexnord is a trusted name when it comes to providing skillfully engineered products that improve productivity and efficiency for industrial applications worldwide. We are committed to exceeding customer expectations in every area of our business: product design, application engineering, operations, and customer service.

Because of our customer focus, we are able to thoroughly understand the needs of your business and have the resources available to work closely with you to reduce maintenance costs, eliminate redundant inventories and prevent equipment down time.

Rexnord represents the most comprehensive portfolio of power transmission and conveying components in the world with the brands you know and trust.

Rexnord is a registered trademark of Rexnord Industries, LLC. Klean Gard is a trademark of Rexnord. Link-Belt is a trademark of Link-Belt Construction Equipment Company. All rights reserved.

WORLDWIDE CUSTOMER SERVICE

AUSTRALIA

Rexnord Australia Pty. Ltd.
Picton, New South Wales
Phone: 61-2-4677-3811
Fax: 61-2-4677-3812

Falk-Rexnord Australia Pty Ltd
Broadmeadow New South Wales
Phone: 61-2-4962-8000
Fax: 61-2-4962-8001

BRAZIL

Rexnord Correntes Ltda.
Sao Leopoldo - RS
Phone: 55-51-579-8022
Fax: 55-51-579-8029

CANADA

Rexnord Canada Ltd.
Scarborough, Ontario
Phone: 1-416-297-6868
Fax: 1-416-297-6873

CHINA

Rexnord China
Shanghai, China
Phone: 86-21-62701942
Fax: 86-21-62701943

EUROPE

Rexnord NV/SA
Mechelen, Belgium
Phone: 32-15-443881
Fax: 32-15-443860

LATIN AMERICA

Rexnord International
Milwaukee, Wisconsin
Phone: 1-414-643-2366
Fax: 1-414-643-3222
E-mail: international1@rexnord.com

MEXICO

Rexnord S. A. de C. V.
Mexico DF, Mexico
Phone: 52-55-9140-3500
Fax: 52-55-9140-3550

SINGAPORE

Rexnord International, Inc.
Singapore City, Singapore
Phone: 65-6338-5622
Fax: 65-6338-5422

UNITED STATES

Customer Service
Phone: 866-Rexnord
(866-739-6673)
E-mail: rexnordcs(state)@rexnord.com
Example: rexnordcssohio@rexnord.com

ALL COUNTRIES NOT LISTED ABOVE

Rexnord International
Milwaukee, Wisconsin
Phone: 1-414-643-2366
Fax: 1-414-643-3222
E-mail: international2@rexnord.com

