

**Link-Belt®** Bearings



**MB®**

**Precision Mounted Bearings**

**Rexnord**  
|||||



---

Mounted Ball Bearing Engineering Section	4-6
--	-----

---

<b>CENTRIK-LOK MOUNTED BALL BEARINGS</b>	<b>7-29</b>
--	-------------

---

General information	7-9
Radial Load Ratings	10-11
Optional Sealing Arrangements	12
Nomenclature	72

---



KCL45 Krown Regal Centrik-Lok Standard Duty Pillow Blocks with Low Shaft Height	13
KC45 Krown Regal Centrik-Lok Standard Duty Pillow Blocks	14
KC55 Krown Regal Centrik-Lok Medium Duty Pillow Blocks	15

---



KFC245 Krown Regal Centrik-Lok Wide 2-bolt Standard Duty Flange Units	16
KFC255 Krown Regal Centrik-Lok Wide 2-bolt Medium Duty Flange Units	17
FC225 K Centrik-Lok Narrow 2-bolt Standard Duty Flange Units	18
FC235 K Centrik-Lok Narrow 2-bolt Medium Duty Flange Units	19

---



KFC445 Krown Regal Centrik-Lok Wide 4-bolt Standard Duty Flange Units	20
KFC455 Krown Regal Centrik-Lok Wide 4-bolt Medium Duty Flange Units	21
FC425 K Centrik-Lok Narrow 4-bolt Standard Duty Flange Units	22
FC435 K Centrik-Lok Narrow 4-bolt Medium Duty Flange Units	23

---

PFC445 K Centrik-Lok Narrow 4-bolt Standard Duty Piloted Flange Units	24
PFC455 K Centrik-Lok Narrow 4-bolt Medium Duty Piloted Flange Units	25

---



KMB45 Krown Regal Centrik-Lok Wide Standard Duty Bearing Inserts	26
KMB55 Krown Regal Centrik-Lok Wide Medium Duty Bearing Inserts	27
KMB25 Krown Regal Centrik-Lok Narrow Standard Duty Bearing Inserts	28
KMB35 Krown Regal Centrik-Lok Narrow Medium Duty Bearing Inserts	29

---

CENTRIK-LOK Bearing Comparison Chart	30-35
--------------------------------------	-------

---

<b>MOUNTED BALL BEARINGS</b>	<b>37-73</b>
------------------------------	--------------

---

General information	37-39
Radial Load Ratings	40-41
Optional Sealing Arrangements	42
Nomenclature	73

---













CL25 Standard Duty Pillow Blocks with Low Shaft Height	43
C25 Standard Duty Pillow Blocks	44
C35 Medium Duty Pillow Blocks	45

---



FC225 2-bolt Standard Duty Flange Units	46
FC235 2-bolt Medium Duty Flange Units	47

**INDEX**
**Page**

	FC425 4-bolt Standard Duty Flange Units	48
	FC435 4-bolt Medium Duty Flange Units	49
	PFC425 4-bolt Standard Duty Piloted Flange Units	50
	PFC435 4-bolt Medium Duty Piloted Flange Units	51
	TC25 Standard Duty Take-up Units	52
	TC35 Medium Duty Take-up Units	53
	TP,TPT,TSP,TSPT "T" Frame Take-ups	54
	TQP Quick Release "T" Frame Take-up	54
	"T" Frame Takeup Standard Duty Pillow Block Mounting	55
	"T" Frame Takeup Tapped Base Pillow Block Mounting	55
	MCHB Screw Conveyor Hanger Units	56
	MEHB Hanger Units	57
	TBC25 Standard Duty Tapped Base Pillow Block	58
	MFB25 Standard Duty 3-bolt Flange Bracket Units	59
	MB25 Standard Duty Bearing Inserts	60
	MB35 Medium Duty Bearing Inserts	61
	FPSR2 Rubber Mounted Flange Units	62
	RER Rubber Mounted Cartridge Units	62
	ER Adapter Series Bearings – Nomenclature	63
	ER Adapter Series Bearings – Set Screw Locking	64
	ER K Adapter Series Bearings – Centrik-Lok	65
	ER Adapter Series Bearings – Bearing Housing Fitting Practice	66
	MSLN Narrow Series Bearings with Cylindrical O.D.'s	67
	MSL Extended Series Bearings with Cylindrical O.D.'s	67
	PS25 Formed Steel Pillow Blocks	68
	FPS225 2-bolt Formed Steel Flange Units	69
	FPS325 3-bolt Round Formed Steel Flange Units	70
	FPST325 3-bolt Triangular Formed Steel Flange Units	71
	Set Screw Mounted Bearing Comparison Charts	74-84

# MOUNTED BEARING ENGINEERING SECTION

## Ball Bearing Size Selection

A bearing should be selected with a load rating the same as or greater than the actual load. Where overloads, shock, vibration or thrust loads are encountered, use the largest equivalent load to select the bearing, as shown in the following three paragraphs.

1. For applications involving frequent overloads, the overload value should be used as the equivalent load.
2. For applications involving shock loads or vibration, add up to 50% of the actual load to find the equivalent load.
3. If thrust loads exceed 50% of the radial load, add the thrust load to 50% of the radial load to determine the equivalent load.

When an L<sub>10</sub> life of over 30,000 hours is required, multiply the actual or equivalent load by the following factors:

- 1.10 for 40,000 hours L<sub>10</sub> life
- 1.26 for 60,000 hours L<sub>10</sub> life
- 1.39 for 80,000 hours L<sub>10</sub> life
- 1.50 for 100,000 hours L<sub>10</sub> life

Find this new value in the table opposite 30,000 hours L<sub>10</sub> life in order to select a bearing.

The L<sub>10</sub> life as given in the table is defined as the number of hours that 90% of a group of bearings will operate before the first evidence of fatigue develops. Average life is approximately five times L<sub>10</sub> life.

Because of the high load permitted at low speeds, shaft strength and housing clamping bolt strength should be checked for low speed operation. Heavy thrust applications require a shouldered shaft back-up against the face of the inner ring or an added thrust collar.

**Mounted bearing units** have the advantage of providing proper load support and reducing design and assembly time. Pre-mounted bearing units offer convenience as well as economy and it is not necessary to spend valuable time selecting bearing housings, seals and different methods of securing the bearings to the shafts. Selection information usually necessary is shaft size, radial and thrust loads, speed and physical mounting limitations and operating environment.

The simplest, most economical mounting is set-screw locking through the inner race...which securely locates the two members. The extended inner race provides maximum shaft contact along with good bearing stability. For some installations, standard commercial shafts are successful with a slip fit in the inner race bore, although some instances, press fitting of the shaft to the inner race is required.

The amount of inner race bore to shaft O.D. clearance that can be tolerated depends upon application and operating conditions. For instance, if dynamic balance is important, a close fitting shaft to inner race bore is very desirable. Severe vibration could be experienced when using undersize shafts of varying degrees resulting in the undersize shaft becoming eccentric in the bore of the inner race, regardless of the type of locking method.

Three types of shafting are normally used in ball bearing pillow block applications. For example, it is very common to utilize commercial grade mild steel shafting. If closer tolerance shafting is required, then either turned, ground and polished or cold drawn, ground and polished shafting is used.

If more precise shafting is required, it can be selected to, or purchased, with a +.0000 –.0005 diameter tolerance and it is usually to the nominal diameter with a negative tolerance.

If the dynamic balance is important, slightly oversize shafting should be used to provide a snug fit with the bore of the inner race. In other words, it should be a line to line fit to an interference fit rather than a line to line to a non-interference fit.

## Special mounted bearings

In addition to standard bearings cataloged, bearings are available with special surface finishes, special sealing arrangements and specialized housing or bearing insert configurations.

## Special surface finishes

A black oxide surface finish treatment can be applied to ball bearing inserts to meet special application requirements. The black oxide finish is applied for corrosion resistance, and provides excellent protection for the majority of application conditions. Also, it is far less costly than a plated bearing or a bearing made entirely of stainless steel.

## Nickel plated pillow blocks



A variety of standard mounted units have been supplied with nickel-plated castings for food processing or food packaging applications. Bearing inserts with black oxide finishes are normally supplied with nickel-plated casting unless otherwise specified. Stainless steel set screws are considered optional and would not be included unless specified. Applications where nickel-plated mountings are being used include: vegetable peeling, fruit and vegetable forming and stacking equipment, shrimp peelers and many conveyor applications where the bearings are exposed to food acids, as well as daily detergent and steam washdowns. Nickel plated housing have excellent corrosion resistance (approaching that of cadmium plating) and wearability similar to chrome plating. These bearings are prelubricated with an odorless, tasteless grease that meets Section 121.2553 subpart F "Lubricants with Incidental Food Contact" of the food additive regulation of the Good and Drug Administration. The lubricant has capabilities to adequately lubricate antifriction bearings under wet or dry conditions and in normal ambient temperatures to an operating temperature of +225°F.

Nickel plated units are available in C25, FC225, FC425, TC25 configurations in 1/2" to 1<sup>15</sup>/<sub>16</sub>" bore sizes. Catalog numbers of nickel plated units are formed by adding the prefix letter N ahead of the standard bearing number. Example – C25-12 standard pillow block becomes NC25-12 with nickel plating and corrosion resistant bearing insert.

# MOUNTED BEARING ENGINEERING SECTION (Cont.)

## Specialized housings or bearing inserts

Specialized housing or bearing insert configurations are frequently supplied to suit application needs. A few examples are:

- Non-standard based to shaft centerline height,
- Relocation of lube fitting,
- Non-standard mounting bolt hole location or shape,
- Triangular flange castings,
- Dust closures, one side of housing,
- Double extended inner ring bearing inserts with set screws on each side,
- Square and hex bore bearing inserts, and
- Triple contact lip sealing, commonly called for in farm equipment applications.

Special housing designs may be proprietary and not available to others. However, in some cases tooling is standard and existing special designs can be made available. Special paint colors or types are also available, and...

Some customers have made use of a special marking option available with MB bearings. The units can be marked with customer identification (name) and/or number. This "personalizes" the unit and the equipment in which it is used.

## Instructions for installation and lubrication of mounted ball bearing units

### CAUTION

Failure to comply with proper installation, lubrication and maintenance procedures could result in catastrophic bearing failure. If operating in an explosive environment or in or around combustible materials, such catastrophic failure could lead to property damage and personal injury.

**Important Notice** The performance of any mounted unit is dependent upon proper installation, lubrication and maintenance. Premature failure may result if recommended instructions are not followed.

### Installation

- 1 The shaft must be clean and free of nicks and burrs. If mounted on used shafting, the bearing must be located on a smooth, unworn section.
  - a. A ground shaft must be used to obtain a snug fit, except where the unit is used for heavy loads, high speeds or where dynamic balance is critical, in which case a light press fit is required. The following shaft diameters and tolerance must be used to obtain a snug fit:

Shaft Diameters, Inches	Tolerances, Inches, From Nominal
1/2 to 1 <sup>15</sup> / <sub>16</sub>	+0.0000 to -0.0005
2 to 3 <sup>1</sup> / <sub>2</sub>	+0.0000 to -0.0010

Heavy loads are greater than 15% of the Basic Dynamic Rating (BDR) of the bearing used in the mounted unit. The Basic Load Ratings are shown on page 10 or page 40. High speeds are those defined as being in excess of 1,500 feet per minute.

- b. To obtain a light press fit, a line-to-line fit between the bearing bore and the shaft diameter must be maintained. Any fit tighter than line-to-line can cause premature bearing failure. Thus, selective fitting of bearing bores and shaft diameters is required to maintain proper light press

fit for heavy loads, high speeds or when dynamic balance is critical.

- c. For moderate thrust loads, shock loads, vibration conditions or higher speeds, the shaft should be spot drilled to provide additional holding. Heavy thrust load applications require a shouldered shaft back-up against the inner ring face, or an added thrust collar.
2. Even very small raised edges and burrs on the mounting surfaces can lead to overstressing and fracture of the housing. Therefore, the support member surface to which the housing will be mounted, and the housing mounting surface, must be clean and free of burrs and nicks that have raised edges, so that a smooth, flat mounting surface is present. Careful handling of mounted units is required to avoid damage to the mounting surface.
3. Slide the unit on the shaft by applying light pressure against the face of the inner ring. **DO NOT HAMMER THE ENDS OF THE INNER RING OR ANY PART OF THE HOUSING.**
4. Bolt the housed units securely to the support members.
5. Tighten the set screws of one bearing locking device to the recommended torque values given in Chart 1, below.
  - a. Bearings with the concentric setscrew locking device have no collar-the set screws in the inner race extension tighten against the shaft.
  - b. Bearings with the CENTRIK-LOK locking device have a collar. The set screws in the collar are started into countersunk holes in the inner race extension. These set screws *must* be tightened to the Chart 1 recommended torque values into these countersunk holes to obtain satisfactory and efficient locking to the shaft.
6. Check the shaft for freedom of rotation. If possible, run the bearings a short time under the load.
7. Tighten all bearing set screws to the Chart 1 recommended torque values.

**CHART 1**

RECOMMENDED SET SCREW TORQUE					
Set Screw Size	Socket Size	Pound-Inches		Pound-Feet	
		Min	Max	Min	Max
#10	3/32	25	33	2.1	2.8
1/4	1/8	65	87	5.4	7.3
5/16	5/32	124	165	10.3	13.8
3/8	3/16	218	290	18.2	24.2

### Lubrication

All standard MB ball bearing mounted units are prelubricated with grease and must be periodically relubricated to obtain full bearing fatigue life. This is even more important when these units are used in a dusty or moist environment. The required lubrication cycle will be dependent upon the operating conditions, speed, temperature, dust, moisture and other environmental conditions. The following lubrication guide must be followed to prevent catastrophic bearing failures:

**LUBRICATION GUIDE**

Conditions	Minimum Relubrication Interval
Dust Moisture	Daily to twice weekly } See par. 2b Twice daily to weekly } on page 6



## MOUNTED BEARING ENGINEERING SECTION (Cont.)

1. Grease should be added slowly while the shaft is rotating, until a slight bead of grease forms at the seals. This indicates the correct amount of grease has been added. A slight grease leakage at the seals is beneficial as it assures lubrication of the seal contacts, purging of old grease from the bearing and provides protection in the form of a grease dam against contamination.

**CAUTION:** Proper care must be exercised during relubrication to avoid any rotating parts that would cause personal injury.

2. MB mounted ball bearing units are prelubricated with lithium base grease for normal operating conditions and a temperature range of  $-20^{\circ}\text{F}$  to  $+275^{\circ}\text{F}$ . These units must be relubricated with a lithium base grease, or a grease recommended by a reputable grease manufacturer as being suitable for ball bearings and compatible with lithium base greases.
  - a. Relubrication will generally cause a slight rise in bearing operating temperature until the bearing has stabilized with the proper amount of lubricant. Under normal conditions, this slight rise in operating temperature should not exceed  $30^{\circ}\text{F}$ . This will usually take place within a period of 10 to 30 minutes following the relubrication.
  - b. Some environmental operating conditions, such as an unusual amount of dust, operation in dirt or in moist environments, will require more frequent relubrication with as much grease as possible while maintaining a normal bearing operating temperature range of ambient to approximately  $210^{\circ}\text{F}$ . Relubrication should be as often as necessary to maintain a slight grease purge at the seals.
  - c. In the event bearings are to be stored in a wet, dusty or corrosive environment, extra protection must be provided by first adding grease and rotating the bearing until the grease is seen at the seals. In addition, fresh grease must be added before operation, when stored under such adverse conditions.
3. Special optional sealing arrangements are available for unusual adverse operating conditions. Normally, a special grease prepack is required in conjunction with special sealing arrangements. The Rexnord Bearing Products Engineering Department should be consulted for special application conditions and/or abnormal or severe environmental conditions.

### IMPORTANT NOTICE

Periodic relubrication, at a frequency that will be determined by application conditions, is absolutely necessary to avoid catastrophic bearing failure.

In addition, periodic inspection must be made to assure continued satisfactory bearing operation. During such periodic inspection, bearing operating temperatures should be checked. If operating temperatures are found to be rising, the reason for this should be determined. It may be that replacement of the mounted bearing is required.

Temperature sensitive crayons and temperature sensitive labels can be used for determining bearing temperature. Marking the housing with temperature sensitive crayon or applying a temperature sensitive label to the housing will indicate if the bearing operating temperature has exceeded a prescribed level. At any time the bearing operating temperature has exceeded a prescribed level, or any time the bearing operating temperature exceeds  $210^{\circ}\text{F}$ , the reason should be determined. Replacement of the mounted unit may be necessary.

Special procedures and safety codes must be followed. This may require the use of protective guards or other devices. Temperature sensitive crayons or labels, protective guards and other safety devices are not provided by MB nor is their use or lack of use the responsibility of Rexnord Bearing Products.

### Bearing Insert Replacement

1. The MB bearing insert has mounted in its spherical outside surface and anti-rotation pin, unless the bearing package is marked “-W/OP”. To be effective, this anti-rotation pin must engage one of the loading slots in the cast housing.
2. In addition to the anti-rotation pin, MB housings and bearing inserts are fitted together to provide controlled limits on torque required to align the insert in the spherical seat of the housing. Failure to observe the prescribed alignment torque values can lead to premature bearing failure. Those alignment torque values can be obtained from the Rexnord Bearing Products Engineering Department.

### CAUTION:

The replacement of MB inserts into housing of other manufacturers can lead to premature bearing failure. The lubrication fittings in other housing designs may not line up with the lubrication groove and hole in the outer ring of the MB bearing insert. If that occurs, the bearing will not receive lubricant at relubrication and early, and possible catastrophic, failure can occur:

3. Installation of an MB bearing insert into an MB cast housing is initiated by installing the bearing into the housing insertion slots with the bearing turned  $90^{\circ}$  from its normal position, and with the anti-rotation pin located in one of the insertion slots. Care must be exercised to avoid shearing the rotation pin when the bearing is gimbaled to its final position, and the bearing must be gimbaled so that the anti-rotation pin (located closer to one face of the bearing out race) is in position toward the insertion slot face of the casting. Further, the bearing insert should be installed so that the lubrication hole in the outer ring outside surface is approximately in line with the lubrication fitting in the housing. The lubrication groove in the outer ring outside surface *must* be under the housing lubrication fitting.
4. After bearing insert assembly in housing, the aligning torque must be checked with a torque wrench to verify satisfactory aligning torque. Failure to do so and/or shearing the anti-rotation pin can lead to spinning of the bearing outer race in the housing with resultant housing wear and premature unit failure.

# KROWN REGAL CENTRIK-LOK MOUNTED Ball Bearings with superior sealing, heavier housings, more positive shaft locking.

The KROWN REGAL series provides premium bearing features...superior sealing, housing strength, better shaft locking...at non-premium prices. These bearings are the result of a design and manufacturing program aimed at supplying maximum bearing value at competitive prices. Our exclusive patented seals and bearing-to-shaft locking devices multiply bearing life and reduce maintenance and replacement to a minimum.

With decades of supply precision ball bearing inserts to leading pillow block and flanged-mounted bearing procedures as well as to machinery and equipment manufacturers, our staff is one of the most experienced in the world.

KROWN REGAL bearings are available from stock in standard duty and medium duty pillow blocks and flange units as cataloged in the following pages. Other sizes and mountings are available on special order, as are specially-engineered to the application bearings. Consult Rexnord Bearing Products for prompt review of your special needs.





# KROWN REGAL CENTRIK-LOK MOUNTED Ball Bearings (cont.)

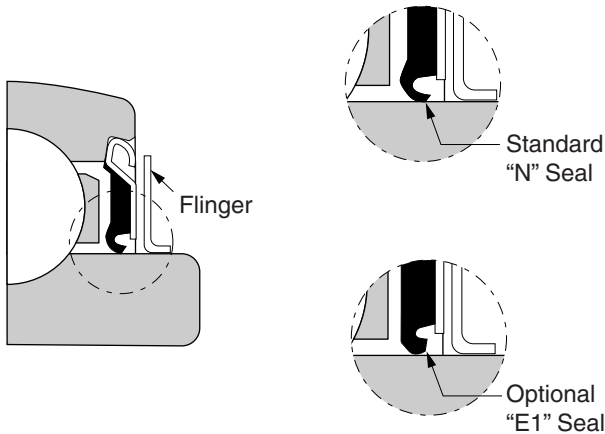

The KROWN REGAL bearing design reduces the three most common causes of bearing failure – seal failure that permits entrance of contaminants or loss of lubricant; insufficient housing strength; and loosening of bearings on rotating shafts. Other features include large diameter balls for high load capacities, nylon retainers for quiet operations, conveniently located lube fittings and superior anti-rotation pin arrangement.

## Molded Lip Seal-Flinger System

The sealing system provides four-way sealing action to effectively keep dirt out and lubricant in. It is combined in KROWN REGAL bearings with steel flingers that throw excessive contaminants away from the bearings and protect the seals from damage by abrasives and impact. Together, the superior seals and added flingers add significantly to bearing life.

## Rugged one-piece cast iron housings

These bearings have heavier cast iron housing than previous designs. The KROWN REGAL foot-mounted pillow blocks and flange mounts are built to withstand heavy loading, shock and external vibration. Finishes are highly resistant to corrosion and abrasion.

## CENTRIK-LOK shaft locking device

Bearing-to-shaft locking is accomplished with the patented CENTRIK-LOK shaft locking device. This method of locking provides excellent holding power versus competitive shaft locking devices. Its clamping action also centers the shaft in the bearing to avoid vibration and noise. It also eliminates shaft damage because set screws do not contact the shaft making bearing removal easier.

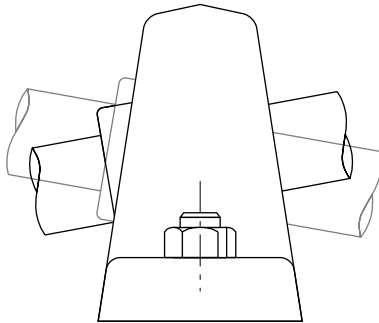

## Spherically-seated bearing insert with anti-rotation pin

The spherical fit between the outer race O.D. and I.D. of the block is precisely controlled for easy shaft alignment. An anti-rotation pin is permanently installed in the bearing insert O.D. It engages one of the housing insertion slots, preventing outer race creep and war of housing. There is no danger of losing a separable pin during field replacement of bearings and no danger of preloading the bearing as is possible in other designs where a lube fitting is tightened against a locking pin.

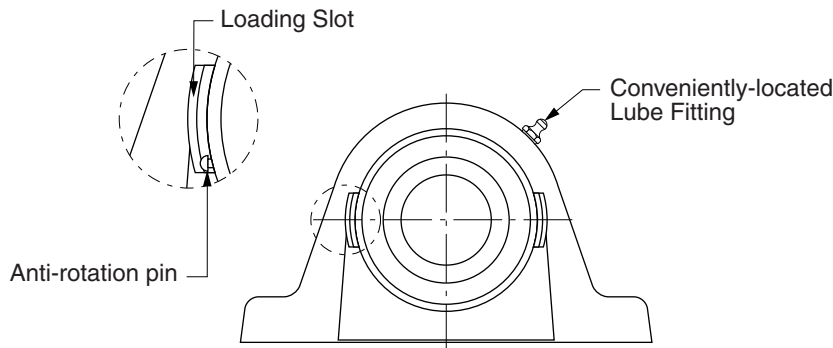

# KROWN REGAL precision mounted ball bearings with patented CENTRIK-LOK shaft locking device.



The CENTRIK-LOK shaft locking device (Pat. No. 4,403,814) assures precise centering of MB KROWN REGAL ball bearing pillow blocks and flange-mounted units on rotating shafts to avoid vibration and noise. What's more, the inherent holding power of this unique design can be far superior to other equivalent competitive bearings. An important feature of the CENTRIK-LOK shaft locking device is that the locking collar is pre-assembled onto the bearing inner race, avoiding the problem of loose, lost or misplaced locking collars. Another feature is that the set screws do not come in contact with the shaft and therefore, do not mark the shaft or leave heavy burrs that make bearing removal difficult.

Most mounted bearing locking devices move the inner race eccentrically on the shaft during locking. This eccentric positioning of the inner race can cause vibration, loosening of locking devices and loss of bearing performance.

One of the drawback of current locking devices that do maintain concentricity has been their lack of shaft-holding power. The CENTRIK-LOK shaft locking device overcomes these shaft-holding limitations and still provides the advantages of true concentricity. The inner race is slotted in four places and a continuous cylindrical locking collar is applied over the inner race slots. Two set screws, located 45° apart, contact the inner race on each side of one of the slots. The two set screws exert force on two of the four inner race segments and the resulting reaction through the collar pulls the remaining two segments against the shaft concentrically.

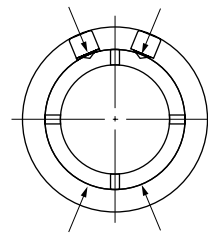
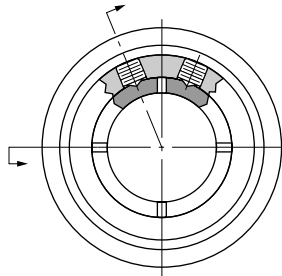
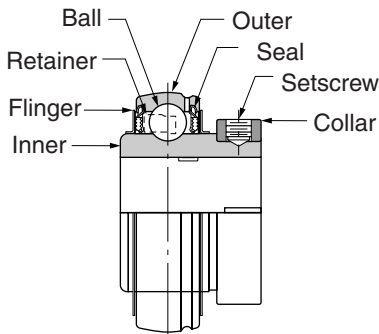

MB CENTRIK-LOK  
Shaft Locking Device

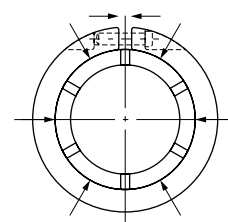

"Hose Clamp" Type  
Locking Device

# KROWN REGAL CENTRIK-LOK MOUNTED BALL BEARINGS – LOAD RATINGS

Basic size	C <sub>0</sub> Static load rating		C Basic load rating		Approximate speed limit RPM*			d Ball diameter inches	N Number of balls	Nd <sup>2</sup>
	Newtons	pounds	Newtons	pounds	N seals	E,E1 seals	Flingers only			
203	4940	1110	8100	1820	14000	9000	15800	19/64	7	0.617
204	6590	1480	9830	2210	10000	7500	13400	5/16	8	0.781
205	7830	1760	10810	2430	9600	6800	11400	5/16	9	0.879
206	11300	2530	15030	3380	8000	5600	9800	3/8	9	1.27
207	15300	3440	19880	4470	6850	4800	8400	7/16	9	1.72
208	19900	4460	25100	5640	6000	4500	7500	1/2	9	2.25
209	20400	4590	25220	5670	5330	4000	6800	1/2	9	2.25
210	23200	5220	27090	6090	4800	3600	6400	1/2	10	2.50
211	29200	6570	33540	7540	4360	3200	5800	9/16	10	3.16
212	36000	8080	40520	9110	4000	3000	5300	5/8	10	3.91
					K seals	TFF seals	Flingers only			
214	38300	8620	48000	10800	3050	2850	4600	11/16	10	4.73
215	37600	8460	47600	10700	2900	2700	4400	11/16	10	4.73
216	50700	11400	59600	13400	2700	2550	4050	3/4	11	6.19
218	64000	14400	73800	16600	2400	2250	3600	7/8	10	7.66

If the load is greater than .15C for 25/35 series or .25C for all others, consult Rexnord Bearing Products.  
\* Approximate speed limits are based on grease lubrication and moderate load.

# KROWN REGAL CENTRIK-LOK MOUNTED BALL BEARINGS – LOAD RATINGS

Basic Bearing	L <sub>10</sub> Minimum Life, Hours	RADIAL LOAD RATINGS IN POUNDS AT VARIOUS REVOLUTIONS PER MINUTE																				
		50	100	200	300	400	500	600	700	800	900	1000	1200	1500	1600	1800	2000	2500	3000	3500	4000	5000
203	3000	-	-	-	-	438	407	383	363	347	334	322	303	282	275	265	255	237	223	212	203	188
	8000	-	-	398	347	315	293	276	262	251	241	233	219	203	198	191	184	171	161	152	146	135
	20000	-	369	293	256	233	216	203	193	184	178	171	161	150	146	141	135	126	118	113	107	100
	40000	369	293	233	203	184	171	161	152	146	141	135	128	118	115	112	107	100	94	89	85	79
	100000	272	216	171	150	135	126	118	113	108	104	100	94	87	85	82	79	73	69	65	63	58
204	3000	-	-	-	-	532	494	465	441	422	406	391	368	342	334	322	310	288	271	257	246	229
	8000	-	-	483	422	383	356	335	318	304	293	282	266	247	241	232	224	208	195	185	178	164
	20000	-	449	356	311	282	262	247	234	224	216	208	195	182	178	171	164	153	144	137	130	121
	40000	449	356	282	247	224	208	195	185	178	171	164	155	144	140	136	130	121	114	108	104	96
	100000	330	262	208	182	164	153	144	137	131	126	122	114	106	104	100	96	89	84	80	76	71
205	3000	-	-	-	-	585	543	511	485	464	446	430	405	376	368	354	341	317	298	283	271	251
	8000	-	-	531	464	421	391	368	350	335	322	311	292	271	265	255	246	229	215	204	195	181
	20000	-	493	391	342	311	288	271	258	246	238	229	215	200	195	188	181	168	158	150	143	133
	40000	493	391	311	271	246	229	215	204	195	188	181	171	158	154	150	143	133	125	119	114	106
	100000	363	288	229	200	181	168	158	150	144	138	134	125	117	114	110	106	98	92	88	84	78
206	3000	-	-	-	-	814	756	711	674	646	621	599	564	524	512	492	475	441	415	394	377	350
	8000	-	-	739	646	586	545	512	487	466	448	432	407	378	368	355	342	318	299	284	272	252
	20000	-	686	545	476	432	401	378	359	343	331	318	299	279	272	262	252	234	220	209	200	185
	40000	686	545	432	378	343	318	299	284	272	262	252	238	220	215	208	200	185	175	166	159	147
	100000	505	401	318	279	252	234	220	209	201	193	186	175	163	159	153	147	136	129	122	117	108
207	3000	-	-	-	-	1070	1000	941	892	854	821	792	746	693	677	651	628	583	549	521	498	463
	8000	-	-	978	854	776	720	678	644	616	592	572	538	500	487	470	453	421	395	375	360	333
	20000	-	908	720	629	572	530	500	475	454	438	421	395	369	360	346	333	310	292	277	264	245
	40000	908	720	572	500	454	421	395	375	360	346	333	314	292	284	275	264	245	231	220	210	195
	100000	669	530	421	369	333	310	292	277	266	255	246	231	215	210	203	195	180	170	161	155	143
208	3000	-	-	-	-	1350	1260	1180	1120	1070	1030	1000	941	874	854	822	793	736	692	658	629	584
	8000	-	-	1230	1070	979	909	855	812	777	748	722	679	630	615	593	572	532	499	473	454	420
	20000	-	1140	909	794	722	669	630	599	573	552	532	499	466	454	437	420	391	368	350	333	309
	40000	1140	909	722	630	573	532	499	473	454	437	420	397	368	359	348	333	309	292	277	266	246
	100000	844	669	532	466	420	391	368	350	335	322	311	292	272	266	256	246	228	215	204	195	181
209	3000	-	-	-	-	1360	1260	1190	1130	1080	1040	1000	946	879	859	826	797	740	696	661	632	587
	8000	-	-	1240	1080	984	914	860	817	782	751	725	683	634	618	596	575	534	501	476	457	423
	20000	-	1150	914	798	725	673	634	602	576	555	534	501	468	457	439	423	393	370	352	335	311
	40000	1150	914	725	634	576	534	501	476	457	439	423	399	370	361	350	335	311	293	279	267	247
	100000	848	673	534	468	423	393	370	352	337	324	313	293	273	267	257	247	229	216	205	196	182
210	3000	-	-	-	-	1460	1360	1280	1210	1160	1110	1070	1010	944	922	887	856	795	748	710	679	629
	8000	-	-	1330	1160	1050	982	924	877	840	807	779	733	681	664	641	617	574	538	511	491	451
	20000	-	1230	982	857	779	723	681	647	618	597	574	538	503	491	472	454	422	398	378	360	330
	40000	1230	982	779	681	618	574	538	511	491	472	454	428	398	387	375	360	334	315	300	287	267
	100000	911	723	574	503	454	422	398	378	362	348	336	315	294	287	276	265	246	232	220	211	191
211	3000	-	-	-	-	1810	1680	1580	1500	1440	1380	1330	1250	1160	1140	1090	1060	984	926	879	841	781
	8000	-	-	1640	1440	1300	1210	1140	1080	1040	1000	965	908	843	823	793	764	711	667	633	608	568
	20000	-	1530	1210	1060	965	895	843	801	766	739	711	667	623	608	584	562	523	492	468	446	416
	40000	1530	1210	965	843	766	711	667	633	608	584	562	530	492	480	465	446	414	390	371	355	325
	100000	1120	895	711	623	562	523	492	468	448	430	416	390	364	355	342	329	305	287	273	261	241
212	3000	-	-	-	-	2190	2030	1910	1810	1740	1670	1610	1520	1410	1380	1320	1280	1180	1110	1060	1010	950
	8000	-	-	1990	1740	1580	1460	1380	1310	1250	1200	1160	1090	1010	994	958	923	859	806	765	734	684
	20000	-	1850	1460	1280	1160	1080	1010	968	925	893	859	806	752	734	706	679	632	595	565	539	509
	40000	1850	1460	1160	1010	925	859	806	765	734	706	679	641	595	580	562	539	500	472	448	429	409
	100000	1360	1080	859	752	679	632	595	565	542	520	503	472	440	429	414	397	368	347	330	316	296
214	3000	-	-	-	-	2600	2410	2270	2150	2060	1980	1910	1800	1670	1630	1570	1510	1400	1320	1260	1210	1160
	8000	-	-	2360	2060	1870	1740	1630	1550	1480	1430	1380	1300	1200	1170	1130	1090	1010	955	905	875	845
	20000	-	2190	1740	1520	1380	1280	1200	1140	1090	1050	1010	955	892	870	837	805	750	705	675	655	635
	40000	2190	1740	1380	1200	1090	1010	955	907	870	837	805	760	705	687	666	639	593	559	539	529	509
	100000	1610	1280	1010	892	805	750	705	670	642	617	596	559	521	509	490	471	437	412	392	382	362
215	3000	-	-	-	-	2570	2390	2250	2130	2040	1960	1890	1780	1650	1620	1550	1500	1390	1330	1280	1230	1180
	8000	-	-	2340	2040	1850	1720	1620	1540	1470	1410	1370	1280	1190	1160	1120	1080	1000	945	895	865	835
	20000	-	2170	1720	1500	1370	1270	1190	1130	1080	1040	1000	946	884	862	829	798	743	703	673	653	633
	40000	2170	1720	1370	1190	1080	1000	946	899	862	829	798	753	699	681	660	633	587	557	537	527	507
	100000	1600	1270	1000	884	798	743	699	664	636	611	591	554	516	504	486	467	433	413	403	393	373
216	3000	-	-	-	-	3220	2990	2820	2670	2560	2460	2370	2230	2070	2030	1950	1880	1740	1680	1630	1580	1530
	8000	-	-	2930	2560	2320	2160	2030	1930	1840	1770	1710	1610	1490	1460	1410	1350	1260	1210	1160	1110	1060
	20000	-	2720	2160	1880	1710	1590	1490	1420	1360	1310	1260	1180	1100	1080	1030	1000	930	880	850	830	810
	40000	2720	2160	1710	1490	1360	1260	1180	1120	1080	1030	1000	943	875	853	827	792	736	706	686	676	656
	100000	2000	1590	1260	1100	1000	930	875	832	797	765	740	694	647	632	609	585	542	522	512	502</	

### Standard Krown Regal optional sealing arrangements

Standard steel clad type N single lip seals have a useful temperature range of  $-40^{\circ}\text{F}$  to  $+225^{\circ}\text{F}$  and can withstand temperatures up to  $250^{\circ}\text{F}$  for intermittent service. The flinger adds protection against contamination, and can shield against radiant heat. Special sealing arrangements are available for higher temperatures and "free-running" or special contamination resistance.

### Special optional sealing arrangements

Suffix-MHFF indicates type H seals and flingers both sides. This provides a sealed, "free-running" bearing with heat shield protection. It is satisfactory for temperatures from  $-40^{\circ}\text{F}$  to  $+275^{\circ}\text{F}$ .

Rexnord Bearing Products *must* be consulted regarding availability of any of these optional sealing configurations.

Examples for ordering:

1. Bearing Insert KMB451-716-MHFFPA
2. Mounted Unit KC451-716-MHFF

### High temperature ball bearing inserts and housed units

Krown Regal mounted ball bearings and KMB45, KMB55 and ER series inserts are available for high temperature applications up to  $400^{\circ}\text{F}$ . The "E1" package provides the following features:

1. Extra Internal Diametral Clearance (DC) based on a  $200^{\circ}\text{F}$  temperature differential between inner and outer races, compensates for the inner race expanding at a faster rate than the outer race and will avoid preloading of the bearings.
2. Steel Retainer (Cage) – 2 piece riveted construction.
3. High Temperature Lubrication – prelubricated with a No. 2 consistency bentone-base grease with petroleum oil. When operated near upper limit, ( $400^{\circ}\text{F}$  to  $450^{\circ}\text{F}$ ) daily relubrication is required.
4. Viton Seals withstand temperatures to  $400^{\circ}\text{F}$ .
5. Steel Flingers are mounted outboard of the Viton seals with an interface fit with the O.D. of the inner ring.

Examples for ordering:

1. Bearing Insert KMB451-716-E1PA
2. Mounted Unit KC451-716-E1

### Free running applications and applications above $400^{\circ}\text{F}$

Sealing options such as -FF (flingers only) for "free running" applications and/or temperatures over  $400^{\circ}\text{F}$  where contamination is not severe. The flinger acts as a labyrinth seal. High temperature bearings require a greater amount of diametral clearance (DC) and a higher temperature lubricant. Consult Rexnord Bearing Products for recommendations. Consult your MB bearing source for price and availability of any special features.

Examples for ordering:

1. Bearing Insert KMB451-716-FFPA
2. Mounted Unit KC451-716-FF

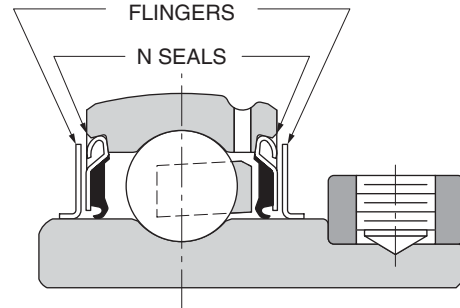

### BASIC KMB45/55 SEALS

KMB25/35 Have no flingers  
214 thru 218 Basic Sizes have  
Nyla-K seals and Flingers

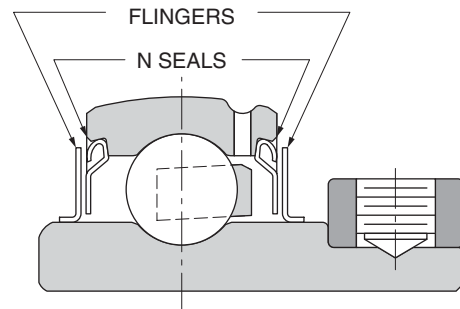

### -MHFF

KMB25/35 Have no H seals  
214 thru 218 Basic Sizes have  
Modified Nyla-K seals and Flingers  
use suffix MKFF

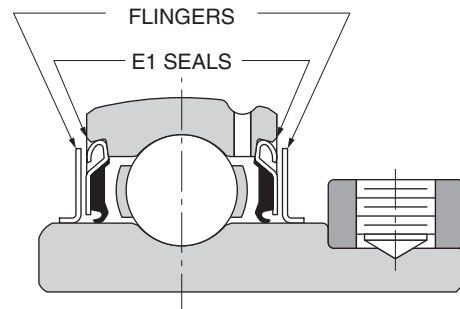

### -E1

KMB25/35 Have no flingers  
214 thru 218 Basic Sizes have  
Viton seals and Flingers  
use suffix TFF

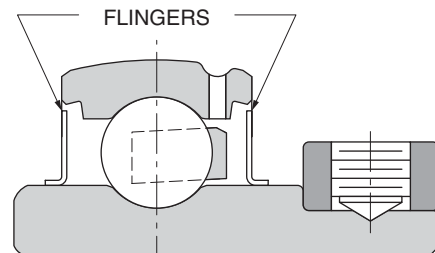

### -FF

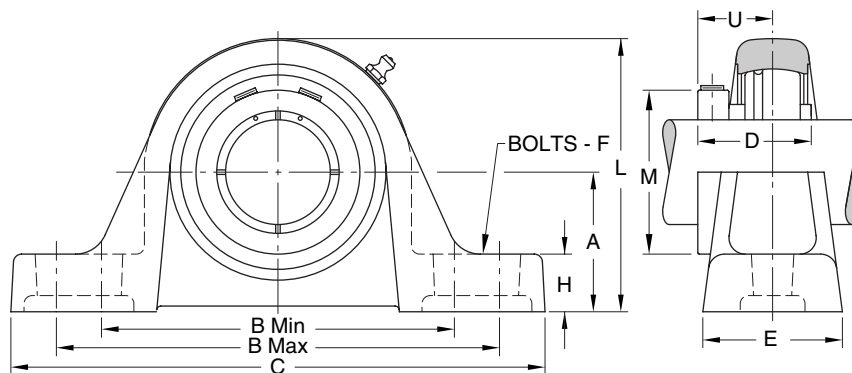

## STANDARD DUTY KROWN REGAL CENTRIK-LOK PILLOW BLOCKS with low shaft height

Elongated bolt holes allow adjustment to facilitate mounting as well as alignment.

Shaft Dia. mm	Inches	Pillow Block Number	Basic Size	A †	B		C	D	E	F Bolts	H	L	M	U	Unit Wt. (lbs/kg)	Bearing Number
					Min.	Max.										
17	1/2 5/8 11/16	KCL45-12	203	1 1/16	3 1/8	4 1/8	5	1 3/32	1 3/8	3/8	3/8	2 5/32	1 1/8	41/64	1.32	KMB45-12-PA
		KCL45-58		26.97	79.40	104.8	127.0	27.79	34.9	10	9.5	54.8	1 13/64	1.28	KMB45-58-PA	
		KCL45-1116		31.75	85.7	106.4	133.3	30.96	38.1	10	11.9	62.7	1 13/64	1.26	KMB45-1116-PA	
20	3/4	KCL45-34	204	1 1/4	3 3/8	4 9/16	5 1/4	1 7/32	1 1/2	3/8	15/32	2 15/32	1 3/8	23/32	1.49	KMB45-34-PA
		KCL45-20		31.75	85.7	106.4	133.3	30.96	38.1	10	11.9	62.7	34.9	18.3	0.7	KMB45-20-PA
25	7/8 15/16 1	KCL45-78	205	1 5/16	3 7/16	4 9/16	5 1/2	1 5/16	1 1/2	3/8	15/32	2 11/16	1 9/16	3/4	1.72	KMB45-78-PA
		KCL45-1516		33.32	87.3	115.9	132.1	33.32	38.1	10	11.9	68.3	39.7	19.0	0.8	KMB45-1516-PA
		KCL45-25		33.32	87.3	115.9	132.1	33.32	38.1	10	11.9	68.3	39.7	19.0	0.8	KMB45-25-PA
30	1 1/8 1 3/16 1 1/4	KCL45-18	206	1 9/16	4 1/8	5 1/8	6 1/4	1 1/2	1 7/8	1/2	17/32	3 1/4	1 13/16	7/8	2.93	KMB45-18-PA
		KCL45-316		39.67	104.8	130.2	158.8	38.10	47.6	12	13.5	82.6	2	2.90	KMB45-316-PA	
		KCL45-14S		39.67	104.8	130.2	158.8	38.10	47.6	12	13.5	82.6	2	2.87	KMB45-14S-PA	
35	1 1/4 1 3/8 1 7/16	KCL45-14	207	1 13/16	4 9/16	5 9/16	6 11/16	1 11/16	1 7/8	1/2	11/16	3 11/16	2 1/4	1	3.85	KMB45-14-PA
		KCL45-38		46.02	115.9	141.3	169.9	42.88	47.6	12	17.5	93.7	2 1/4	3.75	KMB45-38-PA	
		KCL45-716		46.02	115.9	141.3	169.9	42.88	47.6	12	17.5	93.7	57.2	25.4	3.69	KMB45-716-PA
40	1 1/2 1 5/8	KCL45-12	208	1 15/16	5 1/32	6 1/32	7 1/4	1 15/16	2 1/8	1/2	7/8	4	2 1/2	1 3/16	4.99	KMB45-12-PA
		KCL45-58		49.22	127.8	153.2	184.2	49.22	54.0	12	22.2	101.6	63.5	30.2	4.85	KMB45-58-PA
45	1 5/8 1 11/16 1 3/4	KCL45-58L	209	2 1/16	5 13/32	6 17/32	7 3/4	1 15/16	2 1/8	1/2	27/32	4 1/4	2 1/2	1 3/16	5.43	KMB45-58L-PA
		KCL45-1116		52.37	137.3	165.9	196.8	49.22	54.0	12	21.4	108.0	2 11/16	5.36	KMB45-1116-PA	
		KCL45-34		52.37	137.3	165.9	196.8	49.22	54.0	12	21.4	108.0	68.3	30.2	5.29	KMB45-34-PA
50	1 7/8 1 15/16 2	KCL45-78	210	2 3/16	5 27/32	6 27/32	8 1/4	2 1/32	2 3/8	5/8	15/16	4 1/4	2 7/8	1 9/32	6.75	KMB45-78-PA
		KCL45-1516		55.58	148.4	173.8	209.6	51.59	60.3	16	23.8	108.0	73.0	32.5	6.66	KMB45-1516-PA
		KCL452		55.58	148.4	173.8	209.6	51.59	60.3	16	23.8	108.0	73.0	32.5	6.57	KMB452-PA
55	2 2 3/16 2 1/4	KCL452L	211	2 7/16	6 5/16	7 1/2	8 7/8	2 3/16	2 3/8	5/8	15/16	4 15/16	3 1/8	1 5/16	8.40	KMB452L-PA
		KCL452-316		61.92	160.3	190.5	225.4	55.58	60.3	16	23.8	125.4	79.4	33.3	8.10	KMB452-316-PA
		KCL452-14		61.92	160.3	190.5	225.4	55.58	60.3	16	23.8	125.4	79.4	33.3	8.00	KMB452-14-PA
60	2 1/4 2 3/8 2 7/16	KCL452-14L	212	2 11/16	6 29/32	8 5/32	9 5/8	2 9/16	2 3/4	5/8	1	5 1/2	3 1/8	1 9/16	11.81	KMB452-14L-PA
		KCL452-38		68.28	175.4	207.2	244.5	65.07	69.8	16	25.4	139.7	85.7	39.7	11.57	KMB452-38-PA
		KCL452-716		68.28	175.4	207.2	244.5	65.07	69.8	16	25.4	139.7	85.7	39.7	11.45	KMB452-716-PA
75	2 15/16	KCL452-1516	215	3 5/16	8 1/8	10 1/2	13	3 1/16	3 1/2	7/8	1 1/32	6 23/32	3 15/16	1 3/4	24.55	KMB452-1516-PA
				84.12	206.4	266.7	330.2	77.77	88.9	24	26.2	170.7	100.0	44.4	11.1	

Lubrication fitting tap size; 203 thru 205 basic size, 1/4"-28UNF, 206 thru 215 basic size, 1/8"PT

†Tolerance, ±.005" (±0.13mm)

Selection Guide – pages 4-9

Load Ratings – pages 10-11

Additional Information – page 12

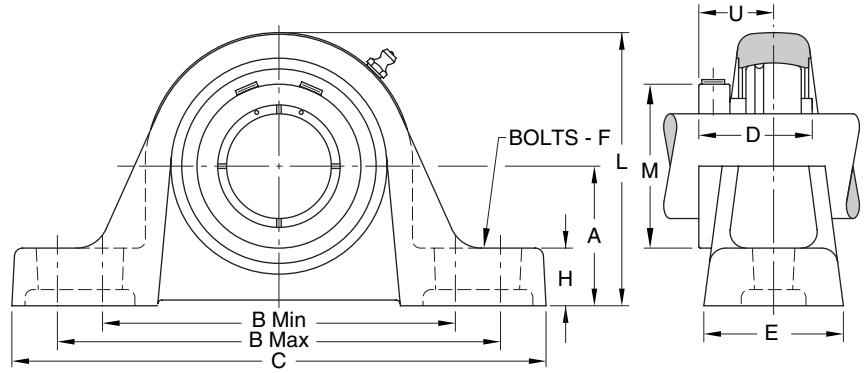

## STANDARD DUTY KROWN REGAL CENTRIK-LOK PILLOW BLOCKS

Elongated bolt holes adjustment to facilitate mounting as well as alignment

Shaft Dia. mm	Inches	Pillow Block Number	Basic Size	A †	B		C	D	E	F Bolts	H	L	M	U	Unit Wt. (lbs/kg)	Bearing Number	
					Min.	Max.											
17	1/2 5/8 11/16	KC45-12	203	1 3/16	3 1/8	4 1/8	5	1 3/32	1 3/8	3/8	1/2	2 9/32	1 1/8	41/64	1.49	KMB45-12-PA	
		KC45-58		30.16	79.40	104.8	127.0	27.79	34.9	10	12.7	57.9	1 13/64		1.45	KMB45-58-PA	
		KC45-1116		3.32	85.7	106.4	133.3	30.96	38.1	10	13.5	64.3	1 13/64		1.43	KMB45-1116-PA	
20	3/4	KC45-34	204	1 5/16	3 3/8	4 3/16	5 1/4	1 7/32	1 1/2	3/8	17/32	2 17/32	1 3/8	23/32	1.66	KMB45-34-PA	
		KC45-20		3.32	85.7	106.4	133.3	30.96	38.1	10	13.5	64.3	34.9		18.3	0.9	KMB45-20-PA
25	7/8 15/16 1	KC45-78	205	1 7/16	3 7/16	4 9/16	5 1/2	1 5/16	1 1/2	3/8	19/32	2 13/16	1 9/16	3/4	1.90	KMB45-78-PA	
		KC45-1516		36.52	87.3	115.9	132.1	33.32	38.1	10	15.1	71.4	39.7		19.0	1.87	KMB45-1516-PA
		KC451		36.52	87.3	115.9	132.1	33.32	38.1	10	15.1	71.4	39.7		19.0	1.84	KMB45-1516-PA
25	1	KC45-25	205	36.52	87.3	115.9	132.1	33.32	38.1	10	15.1	71.4	39.7	19.0	1.0	KMB45-25-PA	
		KC451		36.52	87.3	115.9	132.1	33.32	38.1	10	15.1	71.4	39.7	19.0	1.0	KMB45-25-PA	
30	1 1/8 1 3/16 1 1/4	KC451-18	206	1 11/16	4 1/8	5 1/8	6 1/4	1 1/2	1 7/8	1/2	21/32	3 3/8	1 13/16	7/8	3.11	KMB451-18-PA	
		KC451-316		42.88	104.8	130.2	158.8	38.10	47.6	12	16.7	85.7	2		3.08	KMB451-316-PA	
		KC451-14S		42.88	104.8	130.2	158.8	38.10	47.6	12	16.7	85.7	50.8		22.2	3.05	KMB451-14S-PA
35	1 1/4 1 3/8 1 7/16	KC451-14	207	1 7/8	4 9/16	5 9/16	6 11/16	1 11/16	1 7/8	1/2	3/4	3 3/4	2	1	3.94	KMB451-14-PA	
		KC451-38		47.62	115.9	141.3	169.9	42.88	47.6	12	19.0	95.2	2 1/4		3.84	KMB451-38-PA	
		KC451-716		47.62	115.9	141.3	169.9	42.88	47.6	12	19.0	95.2	2 1/4		3.78	KMB451-716-PA	
40	1 1/2 1 5/8	KC451-12	208	1 15/16	5 1/32	6 1/32	7 1/4	1 15/16	2 1/8	1/2	7/8	4	2 1/2	1 3/16	4.99	KMB451-12-PA	
		KC451-58		49.22	127.8	153.2	184.2	49.22	54.0	12	22.2	101.6	63.5		4.85	KMB451-58-PA	
		KC45-40		49.22	127.8	153.2	184.2	49.22	54.0	12	22.2	101.6	63.5		30.2	2.6	KMB45-40-PA
45	1 5/8 1 11/16 1 3/4	KC451-58L	209	2 1/8	5 13/32	6 17/32	7 3/4	1 15/16	2 1/8	1/2	29/32	4 5/16	2 1/2	1 3/16	5.69	KMB451-58L-PA	
		KC451-1116		53.98	137.3	165.9	196.8	49.22	54.0	12	23.0	109.5	2 11/16		5.62	KMB451-1116-PA	
		KC451-34		53.98	137.3	165.9	196.8	49.22	54.0	12	23.0	109.5	2 11/16		5.55	KMB451-34-PA	
50	1 7/8 1 15/16 2	KC451-78	210	2 1/4	5 27/32	6 27/32	8 1/4	2 1/32	2 3/8	5/8	1	4 9/16	2 7/8	1 9/32	6.83	KMB451-78-PA	
		KC451-1516		57.15	148.4	173.8	209.6	51.59	60.3	16	25.4	115.9	73.0		6.74	KMB451-1516-PA	
		KC452		57.15	148.4	173.8	209.6	51.59	60.3	16	25.4	115.9	73.0		6.65	KMB452-PA	
55	2 2 3/16 2 1/4	KC452L	211	2 1/2	6 5/16	7 1/2	8 7/8	2 3/16	2 3/8	5/8	1	5	2 7/8	1 5/16	8.49	KMB452L-PA	
		KC452-316		63.50	160.3	190.5	225.4	55.58	60.3	16	25.4	127.0	3 1/8		8.29	KMB452-316-PA	
		KC452-14		63.50	160.3	190.5	225.4	55.58	60.3	16	25.4	127.0	3 1/8		8.19	KMB452-14-PA	
60	2 1/4 2 3/8 2 7/16	KC452-14L	212	2 3/4	6 29/32	8 5/32	9 5/8	2 9/16	2 3/4	5/8	1 1/16	5 9/16	3 1/8	1 9/16	11.99	KMB452-14L-PA	
		KC452-38		69.85	175.4	207.2	244.5	65.07	69.8	16	27.0	141.3	3 3/8		11.75	KMB452-38-PA	
		KC452-716		69.85	175.4	207.2	244.5	65.07	69.8	16	27.0	141.3	3 3/8		11.63	KMB452-716-PA	
75	2 15/16	KC452-1516	215	3 1/2	8 1/8	10 1/2	13	3 1/16	3 1/2	7/8	1 7/32	6 29/32	3 15/16	1 3/4	25.05	KMB452-1516-PA	
		KC452-1516		88.90	206.4	266.7	330.2	77.77	88.9	24	31.0	175.4	100.0		44.4	13.6	KMB452-1516-PA

Lubrication fitting tap size; 1/8"PT  
†Tolerance, ±.005" (±0.13mm)

Selection Guide – pages 4-9  
Load Ratings – pages 10-11  
Additional Information – page 12

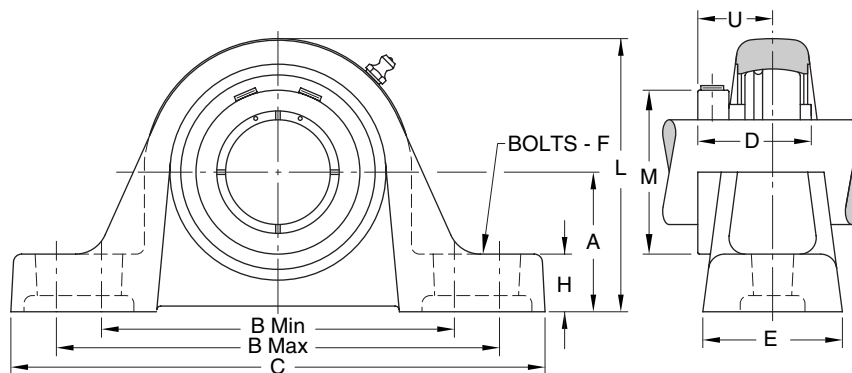

## MEDIUM DUTY KROWN REGAL CENTRIK-LOK PILLOW BLOCKS

Shaft Dia. Inches	Pillow Block Number	Basic Size	A †	B		C	D	E	F Bolts	H	L	M	U	Unit Wt. (lbs/kg)	Bearing Number
				Min.	Max.										
1	KC551	206	1 3/4 44.45	4 1/8 104.8	5 1/8 130.2	6 1/4 158.8	1 1/2 38.10	1 7/8 47.6	1/2 12	23/32 43.7	3 7/16 87.3	1 3/16 46.0	7/8 22.2	3.20 1.5	KMB551-PA
1 3/16	KC551-316	207	1 7/8 47.62	4 9/16 115.9	5 9/16 141.3	6 11/16 169.9	1 11/16 42.88	1 7/8 47.6	1/2 12	3/4 19.0	3 3/4 95.2	2 50.8	1 25.4	3.95 1.8	KMB551-316-PA
1 7/16	KC551-716	208	2 1/8 54.00	5 1/32 127.8	6 1/32 153.2	7 1/4 184.2	1 15/16 49.22	2 1/8 54.0	1/2 12	7/8 22.2	4 3/16 106.4	2 1/4 57.2	1 3/16 30.2	5.04 2.3	KMB551-716-PA
1 1/2	KC551-12	209	2 5/16 58.72	5 13/32 137.3	6 17/32 165.9	7 3/4 196.8	1 15/16 49.22	2 1/8 54.0	1/2 12	29/32 23.0	4 5/16 109.5	2 1/2 63.5	1 3/16 30.2	5.81 2.6	KMB551-12-PA
1 11/16	KC551-1116	210	2 5/16 58.72	5 27/32 148.4	6 27/32 173.8	8 1/4 209.6	2 1/32 51.59	2 3/8 60.3	5/8 16	1 25.4	4 5/8 117.5	2 3/4 69.8	1 9/32 32.5	7.08 3.2	KMB551-1116-PA KMB551-34-PA
1 15/16	KC551-1516		2 1/2 63.50	6 5/16 160.3	7 1/2 190.5	8 7/8 225.4	2 3/16 55.58	2 3/8 60.3	5/8 16	1 25.4	5 127.0	2 7/8 73.0	1 5/16 33.3	8.58 3.9	KMB551-1516-PA KMB552-PA
2 3/16	KC552-316	212	2 3/4 69.85	6 29/32 175.4	8 5/32 207.2	9 5/8 244.5	2 9/16 65.07	2 3/4 69.8	5/8 16	1 1/16 27.0	5 9/16 141.3	3 1/8 79.4	1 9/16 39.7	12.11 5.5	KMB552-316-PA
2 7/16	KC552-716	214	3 76.20	7 1/2 190.5	9 1/2 235.0	11 1/4 285.8	2 3/4 69.85	3 1/4 82.6	3/4 20	1 5/32 29.4	6 1/4 158.8	3 3/4 95.2	1 11/16 42.9	19.2 8.7	KMB552-716-PA KMB552-12-PA
2 1/2	KC552-12		3 1/2 88.90	8 1/8 206.4	10 1/2 266.7	13 330.2	3 1/16 77.77	3 1/2 88.9	7/8 24	1 7/32 31.0	6 29/32 175.4	3 15/16 100.0	1 3/4 44.4	25.68 11.6	KMB552-1116-PA
2 15/16	KC552-1516	216	3 1/2 88.90	8 3/8 225.4	10 1/2 266.7	13 330.2	3 1/4 82.55	3 1/2 88.9	7/8 24	1 9/32 32.5	7 1/4 184.2	4 3/16 106.4	1 15/16 49.2	27.56 12.5	KMB552-1516-PA KMB553-PA
3 3/16	KC553-316		4 101.60	9 13/16 249.2	12 5/16 312.7	15 381.0	3 25/32 96.04	4 3/8 111.1	7/8 24	1 11/32 34.1	8 1/4 209.6	4 13/16 124.6	2 7/32 56.4	41.82 19.0	KMB553-316-PA KMB553-716-PA KMB553-12-PA

Lubrication fitting tap size; 1/8" PT

†Tolerance, ±.005" (±0.13mm)

Selection Guide – pages 4-9

Load Ratings – pages 10-11

Additional Information – page 12

The most popular mounted units are pillow blocks. Pillow blocks provide an integral unit to support shafts parallel to the mounting surface. The casting base has elongated holes for the mounting bolts to provide interchangeability with other competitive makes as well as ease of adjustment during installation. Self-aligning pillow block assemblies usually do not require shimming at the base because self-aligning of the bearing within the housing permits enough adjustment.



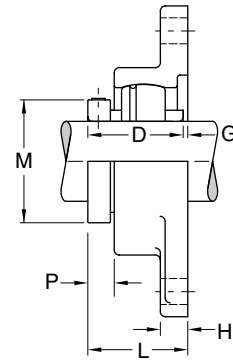
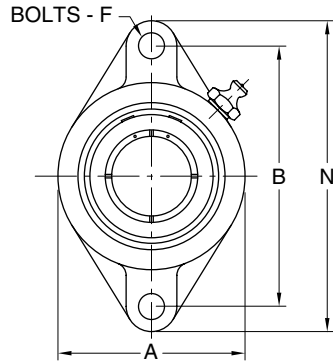

## WIDE 2-BOLT STANDARD DUTY KROWN REGAL CENTRIK-LOK FLANGE UNITS

These flange units incorporate the advantages of foot mounted pillow blocks but are intended for surface mounting, vertical or horizontal, at right angles to the shaft. Bolt holes are spaced for interchangeability with mounting of similar designs.

Shaft Dia.	Flanged Unit Number	Basic Size	A	B	D	F Bolts	G	H	L	M	N	P	Unit Wt. (lbs/kg)	Bearing Number
17	KFC245-12	203	2 5/16	3	1 3/32	3/8	7/64	7/16	1 13/64	1 1/8	3 7/8	19/64	0.95	KMB45-12-PA KMB45-58-PA KMB45-1116-PA
	KFC245-58		33.3	76.20	27.79	10	2.8	11.1	30.6	30.6	98.4	7.5	0.91	
	KFC245-1116												0.89	
20	KFC245-34	204	2 7/16	3 17/32	1 7/32	3/8	1/16	7/16	1 9/32	1 3/8	4 13/32	11/32	1.05	KMB45-34-PA KMB45-20-PA
	KFC245-20		58.4	89.69	30.96	10	1.6	11.1	32.2	34.9	111.9	8.7	0.5	
25	KFC245-78	205	2 3/4	3 57/64	1 5/16	7/16	1/16	17/32	1 3/8	1 9/16	4 7/8	13/32	1.37	KMB45-78-PA KMB45-1516-PA KMB451-PA KMB25-25-PA
	KFC245-1516		69.8	98.82	33.32	10	1.6	13.5	34.9	39.7	123.8	10.3	0.6	
30	KFC2451-18	206	3 3/16	4 19/32	1 1/2	7/16	1/16	17/32	1 9/16	1 13/16	5 9/16	7/16	1.88	KMB451-18-PA KMB451-316-PA KMB451-14S-PA
	KFC2451-316		81.0	116.68	38.10	10	1.6	13.5	39.7	50.8	141.3	11.1	0.8	
35	KFC2451-14	207	3 11/16	5 1/8	1 11/16	1/2	1/16	9/16	1 3/4	2	6 1/8	15/32	2.80	KMB451-14-PA KMB451-38-PA KMB451-716-PA
	KFC2451-38		93.7	130.18	42.88	12	1.6	14.3	44.4	57.2	155.6	11.9	2.70	
	KFC2451-716												2.65	
40	KFC2451-12	208	4 1/8	5 21/32	1 15/16	1/2	5/64	9/16	2 1/64	2 1/2	6 3/4	33/64	3.94	KMB451-12-PA KMB451-58-PA KMB45-40-PA
	KFC2451-58		104.8	143.67	49.22	12	2.0	14.3	51.2	63.5	171.4	18.6	3.80	
45	KFC2451-58L	209	4 3/8	5 27/32	1 15/16	9/16	7/64	9/16	2 3/64	2 1/2	7 1/16	31/64	4.37	KMB451-58L-PA KMB451-1116-PA KMB451-34-PA
	KFC2451-1116		111.1	148.30	49.22	14	2.8	14.3	52.0	68.3	179.4	12.3	4.30	
50	KFC2451-78	210	4 9/16	6 3/16	2 1/32	9/16	1/8	9/16	2 5/32	2 7/8	7 15/32	19/32	4.64	KMB451-78-PA KMB451-1516-PA KMB452-PA
	KFC2451-1516		115.9	157.16	51.59	14	3.2	14.3	54.8	73.0	189.7	15.1	4.55	
55	KFC2452L	211	5	7 1/4	2 3/16	5/8	1/8	13/16	2 5/16	2 7/8	8 1/2	9/16	7.35	KMB452L-PA KMB452-316-PA KMB452-14-PA
	KFC2452-316		127.0	184.15	55.58	16	3.2	20.6	58.7	79.4	215.9	14.3	7.05	
	KFC2452-14												6.95	

Lubrication fitting tap size; 1/8" PT

Selection Guide – pages 4-9

Load Ratings – pages 10-11

Additional Information – page 12

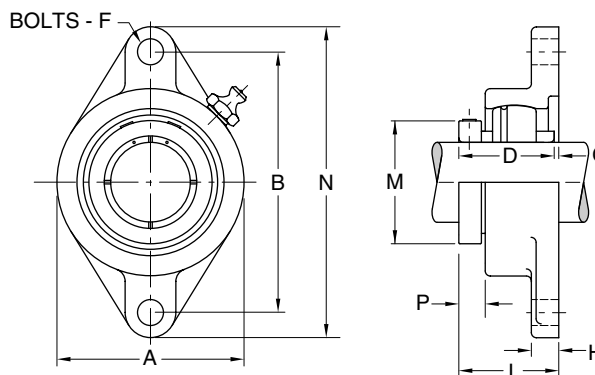

## WIDE 2-BOLT MEDIUM DUTY KROWN REGAL CENTRIK-LOK FLANGE UNITS

These flange units incorporate the advantages of foot mounted pillow blocks but are intended for surface mounting, vertical or horizontal, at right angles to the shaft. Bolt holes are spaced for interchangeability with mounting of similar designs.

Shaft Dia. Inches	Flanged Unit Number	Basic Size	A	B	D	F Bolts	G	H	L	M	N	P	Unit Wt. (lbs/kg)	Bearing Number
1	KFC2551	206	3 <sup>3</sup> / <sub>16</sub> 81.0	4 <sup>19</sup> / <sub>32</sub> 116.68	1 <sup>1</sup> / <sub>2</sub> 38.10	<sup>7</sup> / <sub>16</sub> 10	<sup>1</sup> / <sub>16</sub> 1.6	<sup>17</sup> / <sub>32</sub> 13.5	1 <sup>9</sup> / <sub>16</sub> 39.7	1 <sup>13</sup> / <sub>16</sub> 50.8	5 <sup>19</sup> / <sub>32</sub> 142.1	<sup>7</sup> / <sub>16</sub> 11.1	1.97 0.9	KMB551-PA
1 <sup>3</sup> / <sub>16</sub>	KFC2551-316	207	3 <sup>11</sup> / <sub>16</sub> 93.7	5 <sup>1</sup> / <sub>8</sub> 130.18	1 <sup>11</sup> / <sub>16</sub> 42.88	<sup>1</sup> / <sub>2</sub> 12	<sup>1</sup> / <sub>16</sub> 1.6	<sup>9</sup> / <sub>16</sub> 14.3	1 <sup>3</sup> / <sub>4</sub> 44.4	2 50.8	6 <sup>1</sup> / <sub>8</sub> 155.6	<sup>15</sup> / <sub>32</sub> 11.9	2.81 1.3	KMB551-316-PA
1 <sup>7</sup> / <sub>16</sub>	KFC2551-716	208	4 <sup>1</sup> / <sub>8</sub> 104.8	5 <sup>21</sup> / <sub>32</sub> 143.67	1 <sup>15</sup> / <sub>16</sub> 49.22	<sup>1</sup> / <sub>2</sub> 12	<sup>5</sup> / <sub>64</sub> 2.0	<sup>9</sup> / <sub>16</sub> 14.3	2 <sup>1</sup> / <sub>64</sub> 51.2	2 <sup>1</sup> / <sub>4</sub> 57.2	6 <sup>25</sup> / <sub>32</sub> 172.2	<sup>33</sup> / <sub>64</sub> 18.6	3.99 1.8	KMB551-716-PA
1 <sup>1</sup> / <sub>2</sub>	KFC2551-12	209	4 <sup>3</sup> / <sub>8</sub> 111.1	5 <sup>27</sup> / <sub>32</sub> 148.30	1 <sup>15</sup> / <sub>16</sub> 49.22	<sup>9</sup> / <sub>16</sub> 14	<sup>7</sup> / <sub>64</sub> 2.8	<sup>9</sup> / <sub>16</sub> 14.3	2 <sup>3</sup> / <sub>64</sub> 52.0	2 <sup>1</sup> / <sub>2</sub> 63.5	7 <sup>3</sup> / <sub>32</sub> 180.2	<sup>31</sup> / <sub>64</sub> 12.3	4.49 2.0	KMB551-12-PA
1 <sup>11</sup> / <sub>16</sub> 1 <sup>3</sup> / <sub>4</sub>	KFC2551-1116 KFC2551-34	210	4 <sup>9</sup> / <sub>16</sub> 115.9	6 <sup>3</sup> / <sub>16</sub> 157.16	2 <sup>1</sup> / <sub>32</sub> 51.59	<sup>9</sup> / <sub>16</sub> 14	<sup>1</sup> / <sub>8</sub> 3.2	<sup>9</sup> / <sub>16</sub> 14.3	2 <sup>5</sup> / <sub>32</sub> 54.8	2 <sup>3</sup> / <sub>4</sub> 69.8	7 <sup>7</sup> / <sub>16</sub> 188.9	<sup>19</sup> / <sub>32</sub> 15.1	4.88 2.2	KMB551-1116-PA KMB551-34-PA
1 <sup>15</sup> / <sub>16</sub>	KFC2551-1516	211	5 133.4	7 <sup>1</sup> / <sub>4</sub> 184.15	2 <sup>3</sup> / <sub>16</sub> 55.58	<sup>5</sup> / <sub>8</sub> 16	<sup>1</sup> / <sub>8</sub> 3.2	<sup>13</sup> / <sub>16</sub> 20.6	2 <sup>5</sup> / <sub>16</sub> 58.7	2 <sup>7</sup> / <sub>8</sub> 73.0	8 <sup>1</sup> / <sub>2</sub> 215.9	<sup>9</sup> / <sub>16</sub> 14.3	7.44 3.4	KMB551-1516-PA

Lubrication fitting tap size; <sup>1</sup>/<sub>8</sub>" PT

Selection Guide – pages 4-9

Load Ratings – pages 10-11

Additional Information – page 12

Flange block units, like the foot mounted counterparts, are also provided with a grease fitting for relubrication purposes. The bolt hole size as well as spacing is interchangeable with other competitive units. Flange units are used in place of pillow blocks for side mounting without providing brackets or any other type of structure.

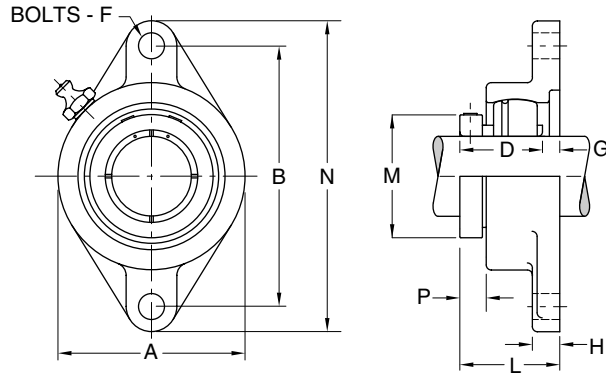

## NARROW 2-BOLT STANDARD DUTY CENTRIK-LOK FLANGE UNITS

These flange units incorporate the advantages of foot mounted pillow blocks but are intended for surface mounting, vertical or horizontal, at right angles to the shaft. Bolt holes are spaced for interchangeability with mounting of similar designs.

Shaft Dia. mm	inches	Flanged Unit Number	Basic Size	A	B	D	F Bolts	G	H	L	M	N	P	Unit Wt. (lbs/kg)	Bearing Number
17	1/2 5/8 11/16	FC225K-12 FC225K-58 FC225K-1116	203	2 5/16	3	63/64	3/8	9/64	3/8	1 1/8	1 1/8 1 13/64 1 13/64	3 7/8	5/16	0.81 0.77 0.75 0.3	KMB25-12-PA KMB25-58-PA KMB25-1116-PA
				58.7	76.20	24.99	10	3.6	9.5	28.6	30.6	98.4	7.9		
20	3/4	FC225K-34 FC225K-20	204	2 3/8	3 17/32	1 5/64	3/8	5/32	7/16	1 9/32	1 3/8	4 13/32	13/32	0.91 0.4	KMB25-34-PA KMB25-20-PA
60.3	89.69	27.38	10	4.0	11.1	32.2	34.9	111.9	10.3						
25	7/8 15/16 1	FC225K-78 FC225K-1516 FC225K1 FC225K-25	205	2 3/4	3 57/64	1 1/8	7/16	1/8	1/2	1 5/16	1 9/16	4 7/8	7/16	1.32 1.29 1.26 0.6	KMB25-78-PA KMB25-1516-PA KMB251-PA KMB25-25-PA
				69.8	98.82	28.58	10	3.2	12.7	33.3	39.7	123.8	11.1		
30	1 1/8 1 3/16 1 1/4	FC225K1-18 FC225K1-316 FC225K1-14S	206	3 3/16	4 19/32	1 19/64	7/16	1/8	17/32	1 1/2	1 13/16 2 2	5 9/16	9/16	1.79 1.75 1.71 0.8	KMB251-18-PA KMB251-316-PA KMB251-PA KMB251-14S-PA
				81.0	116.68	32.94	10	3.2	13.5	38.1	50.8	141.3	14.3		
35	1 1/4 1 3/8 1 7/16	FC225K1-14 FC225K1-38 FC225K1-716	207	3 11/16	5 1/8	1 15/32	1/2	5/32	9/16	1 23/32	2 2 1/4 2 1/4	6 1/8	21/32	2.69 2.59 2.54 1.2	KMB251-14-PA KMB251-38-PA KMB251-716-PA
				93.7	130.18	37.31	12	4.0	14.3	43.7	57.2	155.6	16.7		
40	1 1/2 1 5/8	FC225K1-12 FC225K1-58 FC225K-40	208	4 1/8	5 21/32	1 9/16	1/2	11/64	9/16	1 13/16	2 1/2	6 3/4	21/32	3.47 3.33 1.5	KMB251-12-PA KMB251-58-PA KMB25-40-PA
				104.8	143.67	39.67	12	4.4	14.3	46.0	63.5	171.4	16.7		
45	1 5/8 1 11/16 1 3/4	FC225K1-58L FC225K1-1116 FC225K1-34	209	4 3/8	5 27/32	1 19/32	9/16	11/64	9/16	1 29/32	2 1/2 2 11/16 2 11/16	7 1/16	23/32	3.46 3.39 3.32 1.5	KMB251-58L-PA KMB251-1116-PA KMB251-34-PA
				111.1	148.30	40.49	14	4.4	14.3	48.4	68.3	179.4	18.3		
50	1 7/8 1 15/16 2	FC225K1-78 FC225K1-1516 FC225K2	210	4 9/16	6 3/16	1 41/64	9/16	5/32	5/8	1 29/32	2 7/8	7 15/32	23/32	4.43 4.34 4.25 1.9	KMB251-78-PA KMB251-1516-PA KMB252-PA
				115.9	157.16	41.68	14	4.0	15.9	48.4	73.0	189.7	18.3		
55	2 2 3/16 2 1/4	FC225K2L FC225K2-316 FC225K2-14	211	5	7 1/4	1 3/4	5/8	5/32	23/32	2	2 7/8 3 1/8 3 1/8	8 1/2	11/16	6.04 5.74	KMB252L-PA KMB252-316-PA KMB252-14-PA
				127.0	184.15	44.45	16	4.0	43.7	50.8	79.4	215.9	17.5	2.6	

Lubrication fitting tap size; 203 thru 205 basic size, 1/4"-28UNF, 206 thru 211 basic size, 1/8" PT

Selection Guide – pages 4-9

Load Ratings – pages 10-11

Additional Information – page 12

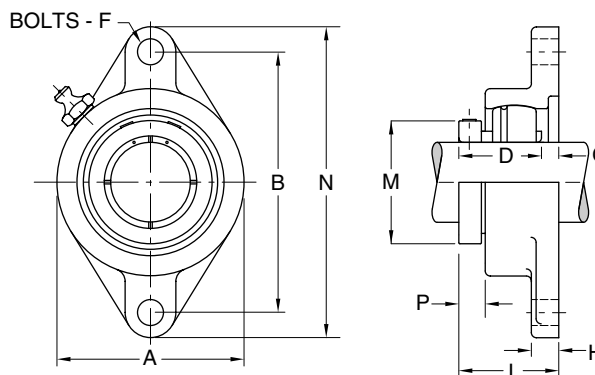

## NARROW 2-BOLT MEDIUM DUTY CENTRIK-LOK FLANGE UNITS

These flange units incorporate the advantages of foot mounted pillow blocks but are intended for surface mounting, vertical or horizontal, at right angles to the shaft. Bolt holes are spaced for interchangeability with mounting of similar designs.

Shaft Dia. Inches	Flanged Unit Number	Basic Size	A	B	D	F Bolts	G	H	L	M	N	P	Unit Wt. (lbs/kg)	Bearing Number
1	FC235K1	206	3 <sup>3</sup> / <sub>16</sub> 81.0	4 <sup>19</sup> / <sub>32</sub> 116.68	1 <sup>19</sup> / <sub>64</sub> 32.94	<sup>7</sup> / <sub>16</sub> 10	<sup>1</sup> / <sub>8</sub> 3.2	<sup>17</sup> / <sub>32</sub> 13.5	1 <sup>1</sup> / <sub>2</sub> 38.1	1 <sup>13</sup> / <sub>16</sub> 46.0	5 <sup>9</sup> / <sub>16</sub> 141.3	<sup>9</sup> / <sub>16</sub> 14.3	2.54 1.2	KMB351-PA
1 <sup>3</sup> / <sub>16</sub>	FC235K1-316	207	3 <sup>11</sup> / <sub>16</sub> 93.7	5 <sup>1</sup> / <sub>8</sub> 130.18	1 <sup>15</sup> / <sub>32</sub> 37.31	<sup>1</sup> / <sub>2</sub> 12	<sup>5</sup> / <sub>32</sub> 4.0	<sup>9</sup> / <sub>16</sub> 14.3	1 <sup>23</sup> / <sub>32</sub> 43.7	2 50.8	6 <sup>1</sup> / <sub>8</sub> 155.6	<sup>21</sup> / <sub>32</sub> 16.7	3.32 1.5	KMB351-316-PA
1 <sup>7</sup> / <sub>16</sub>	FC235K1-716	208	4 <sup>1</sup> / <sub>8</sub> 104.8	5 <sup>21</sup> / <sub>32</sub> 143.67	1 <sup>9</sup> / <sub>16</sub> 39.67	<sup>1</sup> / <sub>2</sub> 12	<sup>11</sup> / <sub>64</sub> 4.4	<sup>9</sup> / <sub>16</sub> 14.3	1 <sup>13</sup> / <sub>16</sub> 46.0	2 <sup>1</sup> / <sub>4</sub> 57.2	6 <sup>3</sup> / <sub>4</sub> 171.4	<sup>21</sup> / <sub>32</sub> 16.7	4.55 2.1	KMB351-716-PA
1 <sup>1</sup> / <sub>2</sub>	FC235K1-12	209	4 <sup>3</sup> / <sub>8</sub> 111.1	5 <sup>27</sup> / <sub>32</sub> 148.30	1 <sup>19</sup> / <sub>32</sub> 40.49	<sup>9</sup> / <sub>16</sub> 14	<sup>11</sup> / <sub>64</sub> 4.4	<sup>9</sup> / <sub>16</sub> 14.3	1 <sup>29</sup> / <sub>32</sub> 48.4	2 <sup>1</sup> / <sub>2</sub> 63.5	7 <sup>1</sup> / <sub>16</sub> 179.4	<sup>23</sup> / <sub>32</sub> 18.3	5.03 2.3	KMB351-12-PA
1 <sup>11</sup> / <sub>16</sub> 1 <sup>3</sup> / <sub>4</sub>	FC235K1-1116 FC235K1-34	210	4 <sup>9</sup> / <sub>16</sub> 115.9	6 <sup>3</sup> / <sub>16</sub> 157.16	1 <sup>41</sup> / <sub>64</sub> 41.68	<sup>9</sup> / <sub>16</sub> 14	<sup>5</sup> / <sub>32</sub> 4.0	<sup>5</sup> / <sub>8</sub> 15.9	1 <sup>29</sup> / <sub>32</sub> 48.4	2 <sup>3</sup> / <sub>4</sub> 69.8	7 <sup>15</sup> / <sub>32</sub> 189.7	<sup>23</sup> / <sub>32</sub> 18.3	5.59 2.5	KMB351-1116-PA KMB351-34-PA
1 <sup>15</sup> / <sub>16</sub>	FC235K1-1516	211	5 127.0	7 <sup>1</sup> / <sub>4</sub> 184.15	1 <sup>3</sup> / <sub>4</sub> 44.45	<sup>5</sup> / <sub>8</sub> 16	<sup>5</sup> / <sub>32</sub> 4.0	<sup>5</sup> / <sub>8</sub> 15.9	2 50.8	2 <sup>7</sup> / <sub>8</sub> 73.0	8 <sup>1</sup> / <sub>2</sub> 215.9	<sup>11</sup> / <sub>16</sub> 17.5	7.69 3.5	KMB351-1516-PA

Lubrication fitting tap size; <sup>1</sup>/<sub>8</sub>" PT

Selection Guide – pages 4-9

Load Ratings – pages 10-11

Additional Information – page 12

2-Bolt flange units, like the foot mounted counterparts, are also provided with grease fitting for relubrication purposes. The bolt hole size as well as spacing is interchangeable with other competitive units. Flange units are also used in place of pillow blocks for side mounting without providing brackets or any other type of structure.

These MB flange units have been designed to maintain a minimum overall thickness with the smallest possible standoff dimension from the mounting face or back of flange to the outboard face of the inner race. This minimizes the necessity of extending shaft lengths and provides interchangeability with other competitive makes.

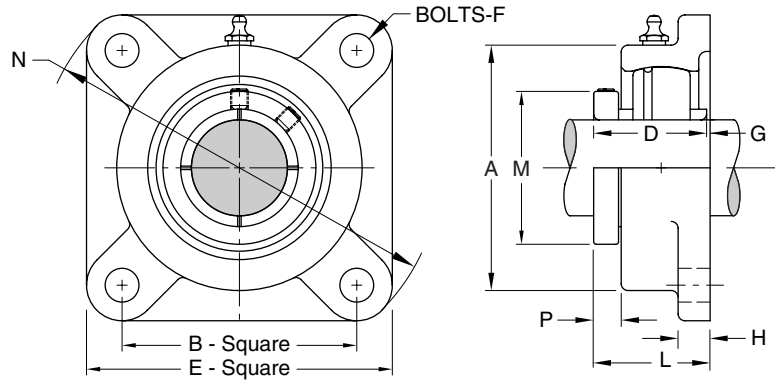

## WIDE 4-BOLT STANDARD DUTY KROWN REGAL CENTRIK-LOK FLANGE UNITS

These flange units incorporate the advantages of foot mounted pillow blocks but are intended for surface mounting, vertical or horizontal, at right angles to the shaft. Bolt holes are spaced for interchangeability with mounting of similar designs.

Shaft Dia. mm	inches	Flanged Unit Number	Basic Size	A	B	D	E	F Bolts	G	H	L	M	N	P	Unit Wt. (lbs/kg)	Bearing Number
17	1/2 5/8 11/16	KFC445-12	203	2 1/8	2 1/8	1 3/32	3	3/8	7/64	7/16	1 13/64	1 1/8	3 7/8	19/64	1.22	KMB45-12-PA
		KFC445-58		54.0	53.98	27.79	76.2	10	2.8	11.1	30.6	30.6	98.4	7.5	1.18	KMB45-58-PA
		KFC445-1116		60.3	63.50	30.96	85.7	10	1.6	11.1	32.2	34.9	111.9	8.7	1.16	KMB45-1116-PA
20	3/4	KFC445-34	204	2 3/8	2 1/2	1 7/32	3 3/8	3/8	1/16	7/16	1 9/32	1 3/8	4 13/32	11/32	1.31	KMB45-34-PA
		KFC445-20		60.3	63.50	30.96	85.7	10	1.6	11.1	32.2	34.9	111.9	8.7	0.6	KMB45-20-PA
25	7/8 15/16 1	KFC445-78	205	2 3/4	2 3/4	1 5/16	3 3/4	7/16	1/16	17/32	1 3/8	1 9/16	4 7/8	11/32	1.81	KMB45-78-PA
		KFC445-1516		69.8	69.85	33.32	95.2	10	1.6	13.5	34.9	39.7	123.8	8.7	1.78	KMB45-1516-PA
		KFC4451														1.75
30	1 1/8 1 3/16 1 1/4	KFC4451-18	206	3 1/4	3 1/4	1 1/2	4 1/4	7/16	1/16	17/32	1 9/16	1 13/16	5 9/16	7/16	3.11	KMB451-18-PA
		KFC4451-316		82.6	82.55	38.10	108.0	10	1.6	13.5	39.7	50.8	141.3	11.1	3.07	KMB451-316-PA
		KFC4451-14S														3.03
35	1 1/4 1 3/8 1 7/16	KFC4451-14	207	3 3/4	3 5/8	1 11/16	4 5/8	1/2	1/16	9/16	1 3/4	2	6 1/8	15/32	3.59	KMB451-14-PA
		KFC4451-38		95.2	92.08	42.88	117.5	12	1.6	14.3	44.4	57.2	155.6	11.9	3.49	KMB451-38-PA
		KFC4451-716														3.44
40	1 1/2 1 5/8	KFC4451-12	208	4 1/8	4	1 15/16	5 1/4	1/2	5/64	9/16	2 1/64	2 1/2	6 3/4	33/64	4.81	KMB451-12-PA
		KFC4451-58		104.8	101.60	49.22	130.2	12	2.0	14.3	51.2	63.5	171.4	18.6	4.67	KMB451-58-PA
		KFC445-40														2.1
45	1 5/8 1 11/16 1 3/4	KFC4451-58L	209	4 3/8	4 1/8	1 15/16	5 3/8	9/16	7/64	9/16	2 3/64	2 1/2	7 1/16	31/64	4.99	KMB451-58L-PA
		KFC4451-1116		111.1	104.78	49.22	136.5	14	2.8	14.3	52.0	68.3	179.4	12.3	4.92	KMB451-1116-PA
		KFC4451-34														4.84
50	1 7/8 1 15/16 2	KFC4451-78	210	4 9/16	4 3/8	2 1/32	5 5/8	9/16	1/8	9/16	2 5/32	2 7/8	7 15/32	19/32	5.52	KMB451-78-PA
		KFC4451-1516		115.9	111.12	51.59	142.9	14	3.2	14.3	54.8	73.0	189.7	15.1	5.43	KMB451-1516-PA
		KFC4452														5.34
55	2 2 3/16 2 1/4	KFC4452L	211	5 1/4	5 1/8	2 3/16	6 3/8	5/8	1/8	13/16	2 5/16	2 7/8	8 1/2	9/16	9.19	KMB452L-PA
		KFC4452-316		133.4	130.18	55.58	161.9	16	3.2	20.6	58.7	79.4	215.9	14.3	8.89	KMB452-316-PA
		KFC4452-14														8.79
60	2 1/4 2 3/8 2 7/16	KFC4452-14L	212	5 1/2	5 5/8	2 9/16	6 7/8	5/8	1/8	13/16	2 11/16	3 1/8	9 1/4	27/32	10.32	KMB452-14L-PA
		KFC4452-38		139.7	142.88	65.07	174.6	16	3.2	20.6	68.3	85.7	235.0	21.4	10.08	KMB452-38-PA
		KFC4452-716														9.96
75	2 15/16	KFC4452-1516	215	6 1/2	6	3 1/16	7 3/4	3/4	1/8	1	3 3/16	3 15/16	10 1/4	7/8	6.48	KMB452-1516-PA
				165.1	152.40	77.77	196.8	20	3.2	25.4	81.0	100.0	260.4	22.2	7.5	

Lubrication fitting tap size; 1/8" PT

Selection Guide – pages 4-9

Load Ratings – pages 10-11

Additional Information – page 12

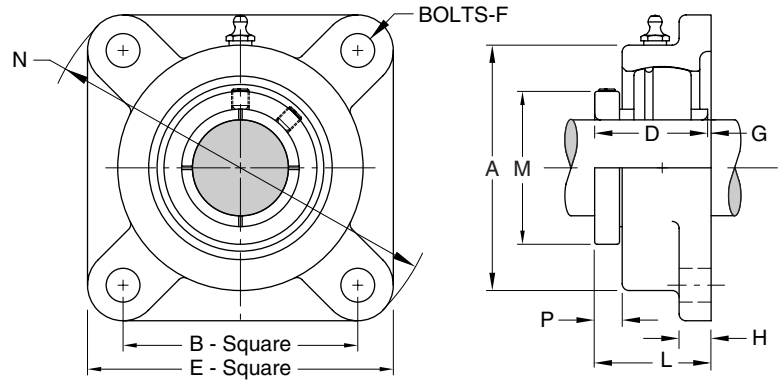

## WIDE 4-BOLT MEDIUM DUTY KROWN REGAL CENTRIK-LOK FLANGE UNITS

These flange units incorporate the advantages of foot mounted pillow blocks but are intended for surface mounting, vertical or horizontal, at right angles to the shaft. Bolt holes are spaced for interchangeability with mounting of similar designs.

Shaft Dia. Inches	Flanged Unit Number	Basic Size	A	B	D	E	F Bolts	G	H	L	M	N	P	Unit Wt. (lbs/kg)	Bearing Number
1	KFC4551	206	3 1/4 82.6	3 1/4 82.55	1 1/2 38.10	4 1/4 108.0	7/16 10	1/16 1.6	17/32 13.5	1 9/16 39.7	1 13/16 46.0	5 19/32 142.1	7/16 11.1	3.15 1.4	KMB551-PA
1 3/16	KFC4551-316	207	3 3/4 95.2	3 5/8 92.08	1 11/16 42.88	4 5/8 117.5	1/2 12	1/16 1.6	9/16 14.3	1 3/4 44.4	2 50.8	6 1/8 155.6	15/32 11.9	3.50 1.6	KMB551-316-PA
1 7/16	KFC4551-716	208	4 1/8 104.8	4 101.60	1 15/16 49.22	5 1/4 130.2	1/2 12	5/64 2.0	9/16 14.3	2 1/64 51.2	2 1/4 57.2	6 25/32 172.2	33/64 18.6	4.87 2.2	KMB551-716-PA
1 1/2	KFC4551-12	209	4 3/8 111.1	4 1/8 104.78	1 15/16 49.22	5 3/8 136.5	9/16 14	7/64 2.8	9/16 14.3	2 3/64 52.0	2 1/2 63.5	7 3/32 180.2	31/64 12.3	5.17 2.3	KMB551-12-PA
1 11/16 1 3/4	KFC4551-1116 KFC4551-34	210	4 9/16 115.9	4 3/8 111.12	2 1/32 51.59	5 5/8 142.9	9/16 14	1/8 3.2	9/16 14.3	2 5/32 54.8	2 3/4 69.8	7 7/16 188.9	19/32 15.1	5.80 2.6	KMB551-1116-PA KMB551-34-PA
1 15/16	KFC4551-1516	211	5 1/4 133.4	5 1/8 130.18	2 3/16 55.58	6 3/8 161.9	5/8 16	1/8 3.2	13/16 20.6	2 5/16 58.7	2 7/8 73.0	8 1/2 215.9	9/16 14.3	9.35 4.2	KMB551-1516-PA
2 3/16	KFC4552-316	212	5 1/2 139.7	5 5/8 142.88	2 9/16 65.07	6 7/8 174.6	5/8 16	1/8 3.2	13/16 20.6	2 11/16 68.3	3 1/8 79.4	9 1/4 235.0	27/32 21.4	10.41 4.7	KMB552-316-PA
2 7/16 2 1/2	KFC4552-716 KFC4552-12	214	6 1/8 155.6	5 7/8 149.22	2 3/4 69.85	7 3/8 187.3	5/8 16	1/4 6.4	13/16 20.6	3 76.2	3 3/4 95.2	9 13/16 249.2	27/32 21.4	14.62 6.6	KMB552-716-PA KMB552-12-PA
2 11/16	KFC4552-1116	215	6 1/2 165.1	6 152.40	3 1/16 77.77	7 3/4 196.8	3/4 20	1/8 3.2	1 25.4	3 3/16 81.0	3 15/16 100.0	10 1/4 260.4	7/8 22.2	17.04 7.7	KMB552-1116-PA
2 15/16 3	KFC4552-1516 KFC4553	216	6 3/4 171.4	6 152.40	3 1/4 82.55	7 3/4 196.8	3/4 20	1/4 6.4	1 25.4	3 1/2 88.9	4 3/16 106.4	10 1/4 260.4	1 1/32 26.2	18.73 8.5	KMB552-1516-PA KMB553-PA
3 3/16 3 7/16 3 1/2	KFC4553-316 KFC4553-716 KFC4553-12	218	7 3/4 196.8	6 3/4 171.45	3 25/32 96.04	8 3/4 222.2	3/4 20	3/16 4.8	1 25.4	3 31/32 100.8	4 13/16 124.6	11 1/4 285.8	1 7/32 31.0	26.25 25.36 11.5	KMB553-316-PA KMB553-716-PA KMB553-12-PA

Lubrication fitting tap size; 1/8" PT

Selection Guide – pages 4-9

Load Ratings – pages 10-11

Additional Information – page 12

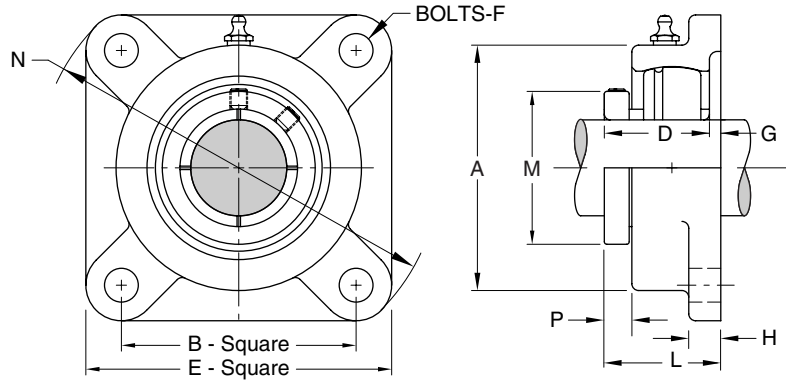

## NARROW 4-BOLT STANDARD DUTY CENTRIK-LOK FLANGE UNITS

These flange units incorporate the advantages of foot mounted pillow blocks but are intended for surface mounting, vertical or horizontal, at right angles to the shaft. Bolt holes are spaced for interchangeability with mounting of similar designs.

Shaft Dia. mm	Shaft Dia. inches	Flanged Unit Number	Basic Size	A	B	D	E	F Bolts	G	H	L	M	N	P	Unit Wt. (lbs/kg)	Bearing Number
17	1/2 5/8 11/16	FC425K-12 FC425K-58 FC425K-1116	203	2 1/16	2 1/8	63/64	3	3/8	9/64	3/8	1 1/8	1 1/8	3 7/8	5/16	0.99	KMB25-12-PA
				52.4	53.98	24.99	76.2	10	3.6	9.5	28.6	30.6	98.4	7.9	0.95	KMB25-58-PA
20	3/4	FC425K-34 FC425K-20	204	2 5/16	2 1/2	1 5/64	3 3/8	3/8	5/32	3/8	1 9/32	1 3/8	4 13/32	13/32	1.30	KMB25-34-PA
				58.7	63.50	27.38	85.7	10	4.0	9.5	32.2	34.9	111.9	10.3	0.6	KMB25-20-PA
25	7/8 15/16 1	FC425K-78 FC425K-1516 FC425K1 FC425K-25	205	2 11/16	2 3/4	1 1/8	3 3/4	7/16	1/8	7/16	1 5/16	1 9/16	4 29/32	7/16	1.71	KMB25-78-PA
				68.3	69.85	28.58	95.2	10	3.2	11.1	33.3	39.7	124.6	11.1	1.68	KMB25-1516-PA
30	1 1/8 1 3/16 1 1/4	FC425K1-18 FC425K1-316 FC425K1-14S	206	3 3/16	3 1/4	1 19/64	4 1/4	7/16	1/8	1/2	1 1/2	1 13/16	5 19/32	9/16	2.50	KMB251-18-PA
				81.0	82.55	32.94	108.0	10	3.2	12.7	38.1	50.8	142.1	14.3	2.46	KMB251-316-PA
35	1 1/4 1 3/8 1 7/16	FC425K1-14 FC425K1-38 FC425K1-716	207	3 11/16	3 5/8	1 15/32	4 5/8	1/2	5/32	1/2	1 23/32	2	6 1/8	2 1/32	3.41	KMB251-14-PA
				93.7	92.08	37.31	117.5	12	4.0	12.7	43.7	57.2	155.6	16.7	3.31	KMB251-38-PA
40	1 1/2 1 5/8	FC425K1-12 FC425K1-58 FC425K-40	208	4 1/16	4	1 9/16	5 1/4	1/2	11/64	9/16	1 13/16	2 1/2	6 25/32	2 1/32	4.49	KMB251-12-PA
				103.2	101.60	39.67	130.2	12	4.4	14.3	46.0	63.5	172.2	16.7	4.35	KMB251-58-PA
45	1 5/8 1 11/16 1 3/4	FC425K1-58L FC425K1-1116 FC425K1-34	209	4 5/16	4 1/8	1 19/32	5 3/8	9/16	11/64	9/16	1 29/32	2 1/2	7 3/32	2 3/32	4.85	KMB251-58L-PA
				109.5	104.78	40.49	136.5	14	4.4	14.3	48.4	68.3	180.2	18.3	4.78	KMB251-1116-PA
50	1 7/8 1 15/16 2	FC425K1-78 FC425K1-1516 FC425K2	210	4 1/2	4 3/8	1 41/64	5 5/8	9/16	5/32	9/16	1 29/32	2 7/8	7 7/16	2 3/32	5.31	KMB251-78-PA
				114.3	111.12	41.68	142.9	14	4.0	14.3	48.4	73.0	188.9	18.3	5.22	KMB251-1516-PA
55	2 2 3/16 2 1/4	FC425K2L FC425K2-316 FC425K2-14	211	5 3/16	5 1/8	1 3/4	6 3/8	5/8	5/32	5/8	2	2 7/8	8 1/2	1 1/16	7.53	KMB252L-PA
				131.8	130.18	44.45	161.9	16	4.0	15.9	50.8	79.4	215.9	17.5	7.23	KMB252-316-PA
60	2 1/4 2 3/8 2 7/16	FC425K2-14L FC425K2-38 FC425K2-716	212	5 7/16	5 5/8	1 57/64	6 7/8	5/8	13/64	11/16	2 3/32	3 1/8	9 9/32	2 1/32	9.25	KMB252-14L-PA
				138.1	142.88	48.03	174.6	16	5.2	17.5	53.2	85.7	235.7	16.7	9.01	KMB252-38-PA
75	2 15/16	FC425K2-1516	215	6 7/16	6	2 1/8	7 3/4	3/4	9/32	3/4	2 13/32	3 15/16	10 1/4	2 3/32	13.19	KMB252-1516-PA
				163.5	152.40	53.98	196.8	20	7.1	19.0	61.1	100.0	260.4	18.3	6.0	

Lubrication fitting tap size; 203 thru 205 basic size, 1/4"-28UNF, 206 thru 215 basic size, 1/8" PT

Selection Guide – pages 4-9

Load Ratings – pages 10-11

Additional Information – page 12

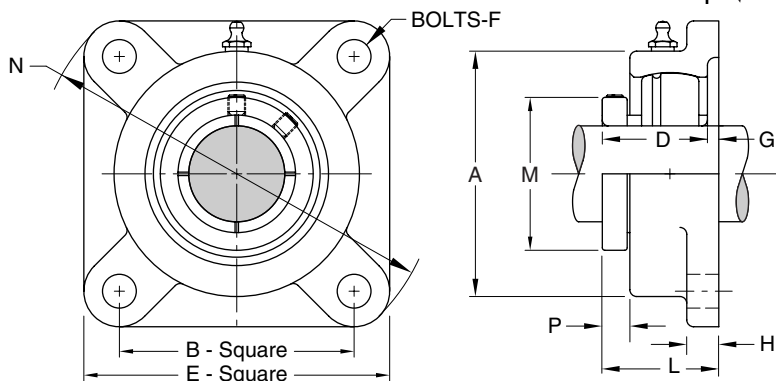

## NARROW 4-BOLT MEDIUM DUTY CENTRIK-LOK FLANGE UNITS

These flange units incorporate the advantages of foot mounted pillow blocks but are intended for surface mounting, vertical or horizontal, at right angles to the shaft. Bolt holes are spaced for interchangeability with mounting of similar designs.

Shaft Dia. Inches	Flanged Unit Number	Basic Size	A	B	D	E	F Bolts	G	H	L	M	N	P	Unit Wt. (lbs/kg)	Bearing Number
1	FC435K1	206	3 3/16 81.0	3 1/4 82.55	1 19/64 32.94	4 1/4 108.0	7/16 10	1/8 3.2	1/2 12.7	1 1/2 38.1	1 13/16 46.0	5 19/32 142.1	9/16 14.3	2.54 1.2	KMB351-PA
1 3/16	FC435K1-316	207	3 11/16 93.7	3 5/8 92.08	1 15/32 37.31	4 5/8 117.5	1/2 12	5/32 4.0	1/2 12.7	1 23/32 43.7	2 50.8	6 1/8 155.6	21/32 16.7	3.32 1.5	KMB351-316-PA
1 7/16	FC435K1-716	208	4 1/16 103.2	4 101.60	1 9/16 39.67	5 1/4 130.2	1/2 12	11/64 4.4	9/16 14.3	1 13/16 46.0	2 1/4 57.2	6 25/32 172.2	21/32 16.7	4.55 2.1	KMB351-7/16-PA
1 1/2	FC435K1-12	209	4 5/16 109.5	4 1/8 104.78	1 19/32 40.49	5 3/8 136.5	9/16 14	11/64 4.4	9/16 14.3	1 29/32 48.4	2 1/2 63.5	7 3/32 180.2	23/32 18.3	5.03 2.3	KMB351-12-PA
1 11/16	FC435K1-1116	210	4 1/2 114.3	4 3/8 111.12	1 41/64 41.68	5 5/8 142.9	9/16 14	5/32 4.0	9/16 14.3	1 29/32 48.4	2 3/4 69.8	7 7/16 188.9	23/32 18.3	5.59 2.5	KMB351-1116-PA KMB351-34-PA
1 3/4	FC435K1-34		4 3/8 111.12	4 3/8 111.12	1 41/64 41.68	5 5/8 142.9	9/16 14	5/32 4.0	9/16 14.3	1 29/32 48.4	2 3/4 69.8	7 7/16 188.9	23/32 18.3	5.59 2.5	KMB351-1116-PA KMB351-34-PA
1 15/16	FC435K1-1516	211	5 3/16 131.8	5 1/8 130.18	1 3/4 44.45	6 3/8 161.9	5/8 16	5/32 4.0	5/8 15.9	2 50.8	2 7/8 73.0	8 1/2 215.9	11/16 17.5	7.69 3.5	KMB351-1516-PA
2 3/16	FC435K2-316	212	5 7/16 138.1	5 5/8 142.88	1 57/64 48.03	6 7/8 174.6	5/8 16	13/64 5.2	11/16 17.5	2 3/32 53.2	3 1/8 79.4	9 9/32 235.7	21/32 16.7	9.34 4.2	KMB352-316-PA
2 7/16	FC435K2-716	214	6 1/8 155.6	5 7/8 149.22	2 5/64 52.78	7 3/8 187.3	5/8 16	19/64 7.5	11/16 17.5	2 3/8 60.3	3 3/4 95.2	9 13/16 249.2	23/32 18.3	12.27 5.5	KMB352-716-PA KMB352-12-PA
2 1/2	FC435K2-12		6 1/8 155.6	5 7/8 149.22	2 5/64 52.78	7 3/8 187.3	5/8 16	19/64 7.5	11/16 17.5	2 3/8 60.3	3 3/4 95.2	9 13/16 249.2	23/32 18.3	12.27 5.5	KMB352-716-PA KMB352-12-PA
2 11/16	FC435K2-1116	215	6 7/16 163.5	6 152.40	2 1/8 53.98	7 3/4 196.8	3/4 20	9/32 7.1	3/4 19.0	2 13/32 61.1	3 15/16 100.0	10 1/4 260.4	23/32 18.3	13.75 6.2	KMB352-1116-PA
2 15/16	FC435K2-1516	216	6 3/4 171.4	6 152.40	2 3/16 55.58	7 3/4 196.8	3/4 20	21/64 8.3	13/16 21.6	2 17/32 64.3	4 3/16 106.4	10 1/4 260.4	11/16 17.5	15.25 6.8	KMB352-1516-PA KMB353-PA
3	FC435K3		6 3/4 171.4	6 152.40	2 3/16 55.58	7 3/4 196.8	3/4 20	21/64 8.3	13/16 21.6	2 17/32 64.3	4 3/16 106.4	10 1/4 260.4	11/16 17.5	15.25 6.8	KMB352-1516-PA KMB353-PA
3 3/16	FC435K3-316	218	7 3/4	6 3/4	2 23/64	8 7/16	3/4	3/8	15/16	2 47/64	4 13/16	11 1/4	11/16	21.11	KMB353-316-PA
3 7/16	FC435K3-716		7 3/4	6 3/4	2 23/64	8 7/16	3/4	3/8	15/16	2 47/64	4 13/16	11 1/4	11/16	20.22	KMB353-716-PA
3 1/2	FC435K3-12		7 3/4	6 3/4	2 23/64	8 7/16	3/4	3/8	15/16	2 47/64	4 13/16	11 1/4	11/16	9.1	KMB353-12-PA

Lubrication fitting tap size; 1/8" PT

Selection Guide – pages 4-9

Load Ratings – pages 10-11

Additional Information – page 12

4-Bolt flange units, like the foot mounted counterparts, are also provided with a grease fitting for relubrication purposes. The bolt hole size as well as spacing is interchangeable with other competitive units. Flange units are also used in place of pillow blocks for side mounting without providing brackets or any other type of structure. Units are also available in the same series and bore sizes as pillow blocks.

These MB flange units have been designed to maintain a minimum overall thickness with the smallest possible standoff dimension from the mounting face or back of flange to the outboard face of the inner race. This minimizes the necessity of extending shaft lengths and provides interchangeability with other competitive makes.



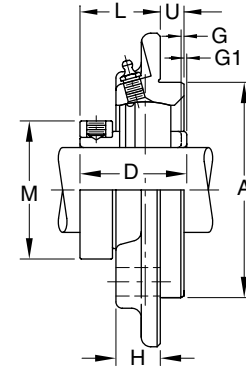
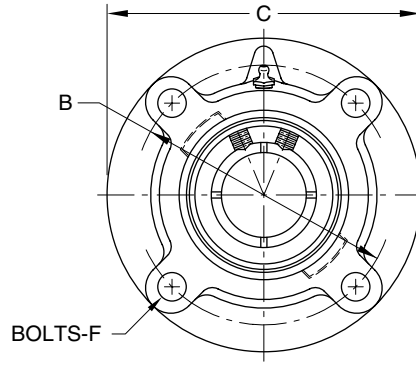

## 4-BOLT STANDARD DUTY CENTRIK-LOK PILOTED FLANGED UNITS

Shaft Dia.		Piloted Flange Unit Number	Basic Size	A †	B	C	C	F Bolts	G	G1	H	L	U	Unit Wt. (lbs/kg)	Bearing Number
mm	Inches														
35	1 1/4	PFC4451-14	207	3.375	4 1/8	5	1 15/32	7/16	1/32	...	7/8	1 23/32	3/8	3.51	KMB451-14-PA
	1 3/8	PFC4451-38		85.72	104.78	127.0	37.31	10	0.8	...	22.2	43.7	9.5	3.41	KMB451-38-PA
	1 7/16	PFC4451-716													3.35
40	1 1/2	PFC4451-12	208	3.625	4 3/8	5 1/4	1 9/16	7/16	...	1/64	7/8	1 35/64	7/16	4.04	KMB451-12-PA
	1 5/8	PFC4451-58		92.08	111.12	133.4	39.67	10	...	0.4	22.2	39.3	11.1	3.90	KMB451-58-PA
		PFC445-40													1.8
45	1 5/8	PFC4451-58L	209	3.625	4 3/8	5 1/4	1 19/32	7/16	...	1/32	7/8	1 17/32	7/16	4.26	KMB451-58L-PA
	1 11/16	PFC4451-1116		92.08	111.12	133.4	40.49	10	...	0.8	22.2	38.9	11.1	4.16	KMB451-1116-PA
	1 3/4	PFC4451-34													4.09
50	1 7/8	PFC4451-78	210	4.250	5 1/8	6 1/8	1 41/64	1/2	...	1/64	7/8	1 39/64	15/32	5.53	KMB451-78-PA
	1 15/16	PFC4451-1516		107.95	130.18	155.6	41.68	12	...	0.4	22.2	40.9	11.9	5.44	KMB451-1516-PA
	2	PFC4452													5.35
55	2	PFC4452L	211	4.500	5 3/8	6 3/8	1 3/4	1/2	...	3/64	7/8	1 37/64	5/8	6.50	KMB452L-PA
	2 3/16	PFC4452-316		114.30	136.52	161.9	44.45	12	...	1.2	22.2	40.1	15.9	6.06	KMB452-316-PA
	2 1/4	PFC4452-14													5.96
60	2 1/4	PFC4452-14L	212	5.000	6	7 1/8	1 57/64	9/16	5/32	...	1	1 29/32	7/8	9.08	KMB452-14L-PA
	2 3/8	PFC4452-38		127.00	152.40	181.0	48.03	14	4.0	...	25.4	48.4	22.2	8.84	KMB452-38-PA
	2 7/16	PFC4452-716													8.72
75	2 15/16	PFC4452-1516	215	6.375	7 1/2	8 3/4	2 1/8	5/8	...	1/8	1	2	1	14.78	KMB452-1516-PA
				161.92	190.50	222.2	53.98	16	...	3.2	25.4	50.8	25.4	6.7	

Lubrication fitting tap size; 1/8" PT

† Tolerance: +.000"-.002" (+0.00mm-0.05mm). Bore tolerance for mounting: +.002"-.000" (+0.05mm-0.00mm)

Selection Guide – pages 4-9

Load Ratings – pages 10-11

Additional Information – page 12

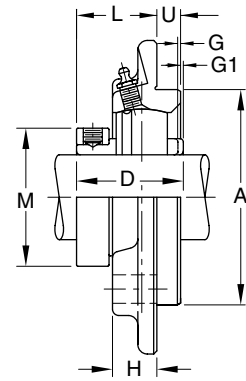
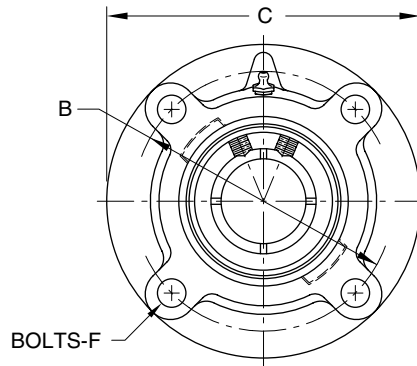

## 4-BOLT MEDIUM DUTY CENTRIK-LOK PILOTED FLANGED UNITS

Shaft Dia. Inches	Piloted Flange Unit Number	Basic Size	A †	B	C	D	F Bolts	G	G1	H	L	U	Unit Wt. (lbs/kg)	Bearing Number
1 3/16	PFC4551-316	207	3.375 85.72	4 1/8 104.78	5 127.0	1 15/32 37.31	7/16 10	1/32 0.8	...	7/8 22.2	1 23/32 43.7	3/8 9.5	3.71 1.7	KMB551-316-PA
1 7/16	PFC4551-716	208	3.625 92.08	4 3/8 111.12	5 1/4 133.4	1 9/16 39.67	7/16 10	...	1/64 0.4	7/8 22.2	1 35/64 39.3	7/16 11.1	3.97 1.8	KMB551-716-PA
1 1/2	PFC4551-12	209	3.625 92.08	4 3/8 111.12	5 1/4 133.4	1 19/32 40.49	7/16 10	...	1/32 0.8	7/8 22.2	1 17/32 38.9	7/16 11.1	4.75 2.2	KMB551-12-PA
1 11/16 1 3/4	PFC4551-1116 PFC4551-34	210	4.250 107.95	5 1/8 130.18	6 1/8 155.6	1 41/64 41.68	1/2 12	...	1/64 0.4	7/8 22.2	1 39/64 40.9	15/32 11.9	5.61 2.5	KMB551-1116-PA KMB551-34-PA
1 15/16 2	PFC4551-1516 PFC4552	211	4.500 114.30	5 3/8 136.52	6 3/8 161.9	1 3/4 44.45	1/2 12	...	3/64 1.2	7/8 22.2	1 37/64 40.1	5/8 15.9	6.27 2.8	KMB551-1516-PA KMB552-PA
2 3/16	PFC4552-316	212	5.000 127.00	5 152.40	7 1/8 181.0	1 57/64 48.03	9/16 14	5/32 4.0	...	1 25.4	1 29/32 48.4	1 25.4	8.99 4.1	KMB552-316-PA
2 7/16 2 1/2	PFC4552-716 PFC4552-12	214	5.500 139.70	6 1/2 165.10	7 5/8 193.7	2 5/64 52.78	9/16 14	5/32 4.0	...	1 25.4	1 31/32 50.0	1 25.4	11.48 5.2	KMB552-716-PA KMB552-12-PA
2 11/16	PFC4552-1116	215	6.375 161.92	7 1/2 190.50	8 3/4 222.2	2 1/8 53.98	5/8 16	...	1/8 3.2	1 25.4	2 50.8	1 25.4	15.44 7.0	KMB552-1116-PA
2 15/16 3	PFC4552-1516 PFC4553	216	6.375 161.92	7 1/2 190.50	8 3/4 222.2	2 3/16 55.58	5/8 16	...	1/16 1.6	1 1/8 28.6	2 1/8 54.	1 25.4	15.86 7.2	KMB552-1516-PA KMB553-PA
3 3/16 3 7/16 3 1/2	PFC4553-316 PFC4553-716 PFC4553-12	218	7.375 187.32	8 5/8 219.08	10 1/4 260.4	2 23/64 59.92	3/4 20	...	17/64 6.8	1 1/8 28.6	2 29/64 62.3	1 1/8 28.6	23.88 23.45 10.6	KMB553-316-PA KMB553-716-PA KMB553-12-PA

Lubrication fitting tap size; 1/8" PT

†Tolerance: +.000"-.002" (+0.00mm-0.05mm). Bore tolerance for mounting: +.002"-.000" (+0.05mm-0.00mm)

Selection Guide – pages 4-9

Load Ratings – pages 10-11

Additional Information – page 12

Piloted flange units provide an accurately machined piloted diameter adjacent to the mounting face to position the unit in a close-fitting bore in the mounting surface. This procedure accurately locates the bearing and shaft without further adjustment or alignment. Typical include machine builders and manufactures of equipment where the supporting side members are line bored to receive the piloted extension at the rear of the flange unit.

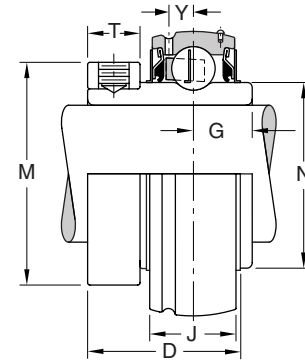
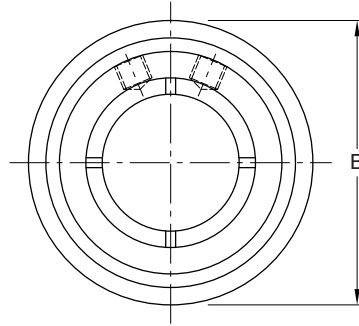

## WIDE STANDARD DUTY KROWN REGAL BEARINGS with CENTRIK-LOK Locking Device

Shaft Dia. mm	inches	Bearing Number	Basic Size	Bore Tolerance	B †	D	G	J	N	M	T		Y	Unit Wt. (lbs/kg)	
											Width	Tap Size			
17	1/2	KMB45-12-PA KMB45-58-PA KMB45-1116-PA	203	+0.0005-0.0000	1.5748	1 3/32	.453	.5118	.941	1 1/8	1 13/64	9/32	#10-32	.158	0.39
	5/8			+0.013-0.000	40.000	27.79	11.51	13.000	23.90	30.6	7.1	M5X.8	4.01	0.35	
	11/16														0.33
20	3/4	KMB45-34-PA KMB45-20-PA	204	+0.0005-0.0000	1.8504	1 7/32	.500	.5906	1.121	1 3/8	11/32	1/4-28	.176	0.43	
				+0.013-0.000	47.000	30.96	12.70	15.000	28.47	34.9	8.7	M6X1	4.47	0.2	
25	7/8	KMB45-78-PA KMB45-1516-PA KMB451-PA KMB45-25-PA	205	+0.0005-0.0000	2.0472	1 5/16	.562	.5906	1.313	1 9/16	11/32	1/4-28	.176	0.55	
	15/16			+0.013-0.000	52.000	33.32	14.27	15.000	33.35	39.7	8.7	M6X1	4.47	0.52	
	1														0.49
30	1 1/8	KMB451-18-PA KMB451-316-PA KMB451-14S-PA	206	+0.0005-0.0000	2.4409	1 1/2	.625	.7087	1.587	1 13/16	2	1/4-28	.202	0.87	
	1 3/16			+0.013-0.000	62.000	38.10	15.88	18.000	40.31	50.8	11.1	M8X1.25	5.13	0.84	
	1 1/4														0.82
35	1 1/4	KMB451-14-PA KMB451-38-PA KMB451-716-PA	207	+0.0005-0.0000	2.8346	1 11/16	.688	.7480	1.847	2	7/16	5/16-24	.227	1.35	
	1 3/8			+0.013-0.000	72.000	42.88	17.48	19.000	46.91	57.2	11.1	M8X1.25	5.77	1.30	
	1 7/16														1.24
40	1 1/2	KMB451-12-PA KMB451-58-PA KMB45-40-PA	208	+0.0005-0.0000	3.1496	1 15/16	.750	.8661	2.083	2 1/2	7/16	5/16-24	.263	1.68	
	1 5/8			+0.013-0.000	80.000	49.22	19.05	22.000	52.91	63.5	11.1	M8X1.25	6.68	1.61	
															0.7
45	1 5/8	KMB451-58L-PA KMB451-1116-PA KMB451-34-PA	209	+0.0005-0.0000	3.3465	1 15/16	.750	.8661	2.281	2 1/2	7/16	5/16-24	.256	1.93	
	1 11/16			+0.013-0.000	85.000	49.22	19.05	22.000	57.94	68.3	11.1	M8X1.25	6.50	1.90	
	1 3/4														1.86
50	1 7/8	KMB451-78-PA KMB451-1516-PA KMB452-PA	210	+0.0005-0.0000	3.5433	2 1/32	.750	.8661	2.475	2 7/8	9/16	3/8-24	.256	2.13	
	1 15/16			+0.013-0.000	90.000	51.59	19.05	22.000	62.86	73.0	14.3	M10X1.5	6.50	2.04	
	2														1.95
55	2	KMB452L-PA KMB452-316-PA KMB452-14-PA	211	+0.0005-0.0000	3.9370	2 3/16	.875	.9843	2.749	2 7/8	9/16	3/8-24	.298	2.58	
	2 3/16			+0.013-0.000	100.000	55.58	22.22	25.000	69.82	79.4	14.3	M10X1.5	7.57	2.46	
	2 1/4														2.36
60	2 1/4	KMB452-14L-PA KMB452-38-PA KMB452-716-PA	212	+0.0006-0.0000	4.3307	2 9/16	1.000	1.0630	3.012	3 1/8	9/16	3/8-24	.330	3.41	
	2 3/8			+0.015-0.000	110.000	65.07	25.4	27.000	76.50	85.7	14.3	M10X1.5	8.38	3.32	
	2 7/16														3.29
75	2 15/16	KMB452-1516-PA	215	+0.0006-0.0000	5.1181	3 1/16	1.312	1.1835	3.632	3 15/16	9/16	3/8-24	.266	5.44	
				+0.015-0.000	130.000	77.77	33.32	30.061	92.25	100.0	14.3	M10X1.5	6.76	2.5	

†Bearing O.D. tolerance; 203 thru 208 basic size, +.0000" -.0005" (+0.000mm -0.013mm); 209 thru 215 basic size, +.0000"-.0006", +0.000mm -0.015mm).

Selection Guide – pages 4-9  
Load Ratings – pages 10-11  
Additional Information – page 12

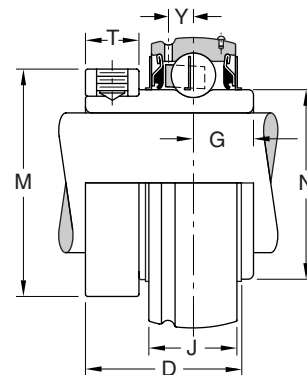
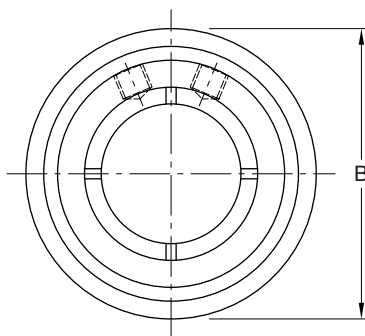

## WIDE MEDIUM DUTY KROWN REGAL BEARINGS with CENTRIK-LOK Locking Device

Shaft Dia. Inches	Bearing number	Basic Size	Bore Tolerance	B †	D	G	J	N	M	T		Y	Unit wt. (lbs/kg)
										Width	Tap Size		
1	KMB551-PA	206	+0.0005-.0000 +0.013-0.000	2.4409 62.000	1 1/2 38.10	.625 15.88	.7087 18.000	1.587 40.31	1 13/16 46.0	7/16 11.1	1/4-28	.202 5.13	0.92 0.4
1 3/16	KMB551-316-PA	207	+0.0005-.0000 +0.013-0.000	2.8346 72.000	1 11/16 42.88	.688 17.48	.7480 19.000	1.847 46.91	2 50.8	7/16 11.1	5/16-24	.227 5.77	1.30 0.6
1 7/16	KMB551-716-PA	208	+0.0005-.0000 +0.013-0.000	3.1496 80.000	1 15/16 49.22	.750 19.05	.8661 22.000	2.083 52.91	2 1/4 57.2	7/16 11.1	5/16-24	.263 6.68	1.61 0.7
1 1/2	KMB551-12-PA	209	+0.0005-.0000 +0.013-0.000	3.3465 85.000	1 15/16 49.22	.750 19.05	.8661 22.000	2.281 57.94	2 1/2 63.5	7/16 11.1	5/16-24	.256 6.50	1.93 0.8
1 11/16 1 3/4	KMB551-1116-PA KMB551-34-PA	210	+0.0005-.0000 +0.013-0.000	3.5433 90.000	2 1/32 51.59	.750 19.05	.8661 22.000	2.475 62.86	2 3/4 69.8	9/16 14.3	3/8-24	.256 6.50	2.29 1.0
1 15/16 2	KMB551-1516-PA KMB552-PA	211	+0.0005-.0000 +0.013-0.000	3.9370 100.000	2 3/16 55.58	.875 22.22	.9843 25.000	2.749 69.82	2 7/8 73.0	9/16 14.3	3/8-24	.298 7.57	2.58 1.1
2 3/16	KMB552-316-PA	212	+0.0006-.0000 +0.015-0.000	4.3307 110.000	2 9/16 65.07	1.000 25.40	1.0630 27.000	3.012 76.50	3 1/8 79.4	9/16 14.3	3/8-24	.330 8.38	3.44 1.6
2 7/16 2 1/2	KMB552-716-PA KMB552-12-PA	214	+0.0010-.0000 +0.025-0.000	4.9213 125.000	2 3/4 69.85	1.062 26.97	1.1545 29.324	3.433 84.58	3 3/4 95.2	9/16 14.3	3/8-24	.266 6.76	5.34 2.4
2 11/16	KMB552-1116-PA	215	+0.0010-.0000 +0.025-0.000	5.1181 130.000	3 1/16 77.77	1.312 33.32	1.1835 30.061	3.632 92.25	3 15/16 100.0	9/16 14.3	3/8-24	.266 6.76	5.86 2.7
2 15/16 3	KMB552-1516-PA KMB553-PA	216	+0.0010-.0000 +0.025-0.000	5.5118 140.000	3 1/4 82.55	1.312 33.32	1.2575 31.940	3.920 99.57	4 3/16 106.4	9/16 14.3	3/8-24	.282 7.16	6.50 2.9
3 3/16 3 7/16 3 1/2	KMB553-316-PA KMB553-716-PA KMB553-12-PA	218	+0.0010-.0000 +0.025-0.000	6.2992 160.000	3 25/32 96.04	1.562 39.67	1.3945 35.420	4.396 111.66	4 13/16 124.6	9/16 14.3	3/8-24	.313 7.95	10.21 4.3

†Bearing O.D. tolerance; 206 thru 208 basic size, +.0000" -.0005" (+0.000mm -0.013mm); 209 thru 215 basic size, +.0000"-.0006", +0.000mm -0.015mm); 216 and 218 basic size, +.0000" -.0008" (+0.000mm -0.020mm).

Selection Guide – pages 4-9

Load Ratings – pages 10-11

Additional Information – page 12

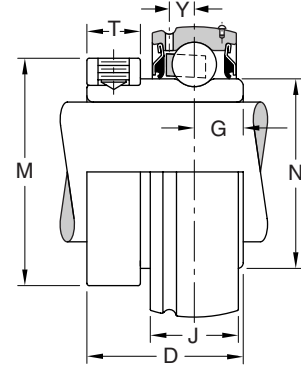
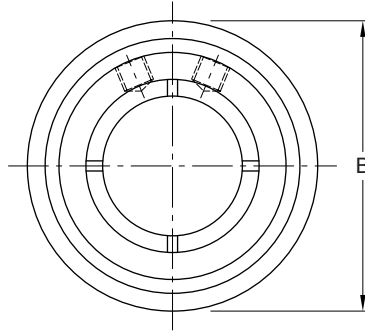

## NARROW STANDARD DUTY KROWN REGAL CENTRIK-LOK BEARINGS

Shaft Dia. mm	inches	Bearing Number	Basic Size	Bore Tolerance	B †	D	G	J	N	M	T		Y	Unit wt. (lbs/kg)										
											Width	Tap Size												
17	1/2 5/8 11/16	KMB25-12-PA	203	+0.0005-.0000	1.5748	63/64	.344	.5118	.941	1 1/8	9/32	#10-32	.158	0.27										
		KMB25-58-PA													40.000	24.99	8.74	13.000	23.90	30.6	7.1	M5X.8	4.01	0.24
		KMB25-1116-PA																						
20	3/4	KMB25-34-PA	204	+0.0005-.0000	1.8504	1 5/64	.361	.5906	1.121	1 3/8	11/32	1/4-28	.176	0.36										
				+0.013-0.000	47.000	27.38	9.17	15.000	28.47	34.9	8.7	M6X1	4.47	0.2										
25	7/8 15/16 1	KMB25-78-PA	205	+0.0005-.0000	2.0472	1 1/8	.367	.5906	1.313	1 9/16	11/32	1/4-28	.176	0.48										
		KMB25-1516-PA													52.000	28.58	9.32	15.000	33.35	39.7	8.7	M6X1	4.47	0.45
		KMB25-25-PA																						
30	1 1/8 1 3/16 1 1/4	KMB251-18-PA	206	+0.0005-.0000	2.4409	1 19/64	.397	.7087	1.587	1 13/16	7/16	1/4-28	.202	0.76										
		KMB251-316-PA													62.000	32.94	10.08	18.000	40.31	50.8	11.1	M8X1.25	5.13	0.74
		KMB251-14S-PA																						
35	1 1/4 1 3/8 1 7/16	KMB251-14-PA	207	+0.0005-.0000	2.8346	1 15/32	.442	.7480	1.847	2	7/16	5/16-24	.227	1.13										
		KMB251-38-PA													72.000	37.31	11.23	19.000	46.91	57.2	11.1	M8X1.25	5.77	1.08
		KMB251-716-PA																						
40	1 1/2 1 5/8	KMB251-12-PA	208	+0.0005-.0000	3.1496	1 9/16	.474	.8661	2.083	2 1/2	7/16	5/16-24	.263	1.45										
		KMB251-58-PA													80.000	39.67	12.04	22.000	52.91	63.5	11.1	M8X1.25	6.68	1.31
		KMB251-58-PA																						
45	1 5/8 1 11/16 1 3/4	KMB251-58L-PA	209	+0.0005-.0000	3.3465	1 19/32	.477	.8661	2.281	2 1/2	7/16	5/16-24	.256	1.62										
		KMB251-1116-PA													85.000	40.49	12.12	22.000	57.94	68.3	11.1	M8X1.25	6.50	1.59
		KMB251-34-PA																						
50	1 7/8 1 15/16 2	KMB251-78-PA	210	+0.0005-.0000	3.5433	1 41/64	.486	.8661	2.475	2 7/8	9/16	3/8-24	.256	1.84										
		KMB251-1516-PA													90.000	41.68	12.34	22.000	62.86	73.0	14.3	M10X1.5	6.50	1.75
		KMB252-PA																						
55	2 2 3/16 2 1/4	KMB252L-PA	211	+0.0005-.0000	3.9370	1 3/4	.541	.9843	2.749	2 7/8	9/16	3/8-24	.298	2.44										
		KMB252-316-PA													100.000	44.45	13.74	25.000	69.82	79.4	14.3	M10X1.5	7.57	2.24
		KMB252-14-PA																						
60	2 1/4 2 3/8 2 7/16	KMB252-14L-PA	212	+0.0006-.0000	4.3307	1 57/64	.582	1.0630	3.012	3 1/8	9/16	3/8-24	.330	2.93										
		KMB252-38-PA													110.000	48.03	14.78	27.000	76.50	85.7	14.3	M10X1.5	8.38	2.78
		KMB252-716-PA																						
75	2 15/16	KMB252-1516-PA	215	+0.0006-.0000	5.1181	2 1/8	.659	1.1835	3.632	3 15/16	9/16	3/8-24	.266	4.40										
				+0.015-0.000	130.000	53.98	16.74	30.061	92.25	100.0	14.3	M10X1.5	6.76	2.0										

†Bearing O.D. tolerance; 203 thru 208 basic size, +.0000" -.0005" (+0.000mm -0.013mm); 209 thru 215 basic size, +.0000"-.0006", +0.000mm -0.015mm).

Selection Guide – pages 4-9  
 Load Ratings – pages 10-11  
 Additional Information – page 12

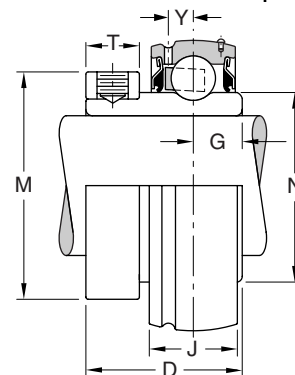
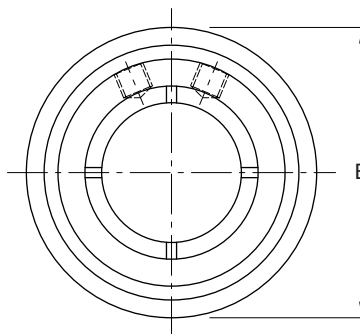

## NARROW MEDIUM DUTY KROWN REGAL CENTRIK-LOK BEARINGS

Shaft Diameter Inches	Bearing Number	Basic Size	Bore Tolerance	B †	D	G	J	N	M	T		Y	Unit wt. (Lbs/Kg)
										Width	Tap Size		
1	KMB351-PA	206	+0.0005-0.0000 +0.013-0.000	2.4409 62.000	1 19/64 32.94	.397 10.08	.7087 18.000	.587 40.31	1 13/16 46.0	7/16 11.1	1/4-28	.202 5.13	0.92 0.4
1 3/16	KMB351-316-PA	207	+0.0005-0.0000 +0.013-0.000	2.8346 72.000	1 15/32 37.31	.442 11.23	.7480 19.000	1.847 46.91	2 50.8	7/16 11.1	5/16-24	.227 5.77	1.30 0.6
1 7/16	KMB351-716-PA	208	+0.0005-0.0000 +0.013-0.000	3.1496 80.000	1 9/16 39.67	.474 12.04	.8661 22.000	2.083 52.91	2 1/4 57.2	7/16 11.1	5/16-24	.263 6.68	1.61 0.7
1 1/2	KMB351-12-PA	209	+0.0005-0.0000 +0.013-0.000	3.3465 85.000	1 19/32 40.49	.477 12.12	.8661 22.000	2.281 57.94	2 1/2 63.5	7/16 11.1	5/16-24	.256 6.50	1.93 0.8
1 11/16 1 3/4	KMB351-1116-PA KMB351-34-PA	210	+0.0005-0.0000 +0.013-0.000	3.5433 90.000	1 41/64 41.68	.486 12.34	.8661 22.000	2.475 62.86	2 3/4 69.8	9/16 14.3	3/8-24	.256 6.50	2.29 1.0
1 15/16	KMB351-1516-PA	211	+0.0005-0.0000 +0.013-0.000	3.9370 100.000	1 3/4 44.45	.541 13.74	.9843 25.000	2.749 69.82	2 7/8 73.0	9/16 14.3	3/8-24	.298 7.57	2.58 1.1
2 3/16	KMB352-316-PA	212	+0.0006-0.0000 +0.015-0.000	4.3307 110.000	1 57/64 48.03	.582 14.78	1.0630 27.000	3.012 76.50	3 1/8 79.4	9/16 14.3	3/8-24	.330 8.38	3.44 1.6
2 7/16 2 1/2	KMB352-716-PA KMB352-12-PA	214	+0.0010-0.0000 +0.025-0.000	4.9213 125.000	2 5/64 52.78	.644 16.36	1.1545 29.324	3.433 84.58	3 3/4 95.2	9/16 14.3	3/8-24	.266 6.76	4.67 2.0
2 11/16	KMB352-1116-PA	215	+0.0010-0.0000 +0.025-0.000	5.1181 130.000	2 1/8 53.98	.659 16.74	1.1835 30.061	3.632 92.25	3 15/16 100.0	9/16 14.3	3/8-24	.266 6.76	4.78 2.2
2 15/16 3	KMB352-1516-PA KMB353-PA	216	+0.0010-0.0000 +0.025-0.000	5.5118 140.000	2 3/16 55.58	.696 17.68	1.2575 31.940	3.920 99.57	4 3/16 106.4	9/16 14.3	3/8-24	.282 7.16	5.80 2.5
3 3/16 3 7/16 3 1/2	KMB353-316-PA KMB353-716-PA KMB353-12-PA	218	+0.0010-0.0000 +0.025-0.000	6.2992 160.000	2 23/64 59.92	.804 20.42	1.3945 35.420	4.396 111.66	4 13/16 124.6	9/16 14.3	3/8-24	.313 7.95	8.71 7.82 3.5

†Bearing O.D. tolerance; 206 thru 208 basic size, +.0000" -.0005" (+0.000mm -0.013mm); 209 thru 215 basic size' +.0000"-0.0006", +0.000mm -0.015mm); 216 and 218 basic size, +.0000" -.0008" (+0.000mm -0.020mm).

Selection Guide – pages 4-9  
Load Ratings – pages 10-11  
Additional Information – page 12

# PILLOW BLOCK COMPARISON CHARTS

The competitive manufacturers are listed in alphabetical order to provide a convenient source of unit substitution. This data is based on the shaft center height distances. This does not mean these competitive units are interchangeable in all respects. The bearings can be considered interchangeable in most instances, but should be checked if complete dimensional interchangeability is essential.

## KROWN REGAL CENTRIK-LOK KCL45 STANDARD DUTY PILLOW BLOCKS with Low Shaft Height

MB KCL45 Shaft Dia.	Link-Belt PL3U PL3Y	Browning MPLS MPLE	Dodge SCB SXR	Fafnir RAK	SKF SYH-WM	Sealmaster NPL NPL-T
1/2	2B08	208		1/2		8
±9/16	210	210		9/16		9
5/8	211			5/8		10
11/16				11/16		11
3/4	212	212	3/4	3/4	3/4	12
±13/16						
±13/16 L	214	214	7/8	13/16	13/16	13
7/8	215	215	15/16	7/8	7/8	14
15/16	216	216	1	15/16	15/16	15
1			1	1	1	16
±1 1/16	218	218	1 1/16	1 1/16	1 1/16	17
1 1/8	219	219	1 1/8	1 1/8	1 1/8	18
1 3/16	2E20	220S	1 3/16	1 3/16	1 3/16	19
1 1/4 S			1 1/4 (206)			20R
1 1/4	220	220	1 1/4 (207)	1 1/4	1 1/4	20
1 5/16	221		1 5/16	1 5/16	1 5/16	21
1 3/8	222	222	1 3/8	1 3/8	1 3/8	22
1 7/16	223	223	1 7/16	1 7/16	1 7/16	23
1 1/2	224	224	1 1/2	1 1/2	1 1/2	24
±1 9/16			SCB1 5/8	1 9/16		25
1 5/8						
±1 5/8 L	226	226	SXB1 5/8	1 5/8	1 5/8	26
1 11/16	227	227	1 11/16	1 11/16	1 11/16	27
1 3/4	228	228	1 3/4	1 3/4	1 3/4	28
±1 13/16						
±1 13/16 L				13/16		29
1 7/8				1 7/8		30
1 15/16	231	231	1 15/16	1 15/16	1 15/16	31
2	2E32		2			32R
2 L	232	232		2	2	32
±2 1/16				2 1/16		
2 1/8	235	235	2 3/16	2 1/8	2 3/16	34
2 3/16			SCB2 1/4	2 3/16		35
2 1/4						
±2 1/4 L		236	SXR2 1/4	2 1/4	2 1/4	36
2 5/16				2 5/16		
2 3/8		239		2 3/8		38
2 7/16			2 7/16	2 7/16	2 7/16	39
±2 5/8						
±2 11/16				2 11/16		
±2 3/4						
±2 13/16						
±2 7/8						
2 15/16				2 15/16		

‡Not always available from stock. Consult Rexnord Bearing Products for availability.

## PILLOW BLOCK COMPARISON CHARTS (cont)

The competitive manufacturers are listed in alphabetical order to provide a convenient source of unit substitution. This data is based on the shaft center height distances. This does not mean these competitive units are interchangeable in all respects. The bearings can be considered interchangeable in most instances, but should be checked if complete dimensional interchangeability is essential.

### KROWN REGAL CENTRIK-LOK KC45 STANDARD DUTY PILLOW BLOCKS

MB KC45 Shaft Dia.	Link-Belt P3U P3Y	Browning VPLS	Dodge SC SXR	Fafnir RASC RAS	SKF SY-TM	Sealmaster NPL
1/2	2B08	208	1/2†	1/2	1/2†	8
‡9/16	210	210	5/8†	9/16	5/8†	9
5/8	211			5/8		10
11/16				11/16		11
3/4	212	212	3/4	3/4	3/4	12
‡13/16						
‡13/16 L	214	214	7/8	13/16	13/16	13
7/8	215	215	15/16	7/8	7/8	14
15/16	216	216	1	15/16	15/16	15
1			1	1	1	16
‡11/16	218	218	11/16†	11/16	11/16	17
1/8	219	219	11/8†	11/8	11/8	18
13/16	2E20	220S	13/16†	13/16	13/16	19
11/4 S			11/4 (206)†	11/4A	11/4A	20R
11/4	220	220	11/4 (207)	11/4	11/4	20
15/16	221		15/16	15/16	15/16	21
13/8	222	222	13/8	13/8	13/8	22
17/16	223	223	17/16	17/16	17/16	23
11/2	224	224†	11/2†	11/2	11/2	24
‡13/16			19/16	19/16		25
15/8			SC15/8†			
‡15/8 L	226	226	SXR15/8	15/8	15/8	26
111/16	227	227	111/16	111/16	111/16	27
13/4	228	228	13/4	13/4	13/4	28
‡113/16						
‡113/16 L				13/16		29
17/8	231	231	15/16	17/8		30
115/16	2E32		2	115/16	115/16	31
2			2			32R
2 L	232	232		2	2	32
‡21/16				21/16		
21/8	235	235	23/16	21/8	23/16	34
23/16			SC21/4	23/16		35
21/4						
‡21/4 L	236	236	SXR21/4	21/4	21/4†	36
25/16				25/16		
23/8	239	239	27/16	23/8	27/16†	38
27/16				27/16		39
‡25/8						
‡211/16	243				211/16	
‡23/4	244				23/4†	
‡213/16						
‡27/8	247		215/16	215/16†	215/16†	
‡215/16						

‡Not always available from stock. Consult Rexnord Bearing Products for availability.

† Denotes variation in shaft center height distance.



## PILLOW BLOCK COMPARISON CHARTS (cont)

The competitive manufacturers are listed in alphabetical order to provide a convenient source of unit substitution. This data is based on the shaft center height distances. This does not mean these competitive units are interchangeable in all respects. The bearings can be considered interchangeable in most instances, but should be checked if complete dimensional interchangeability is essential.

### KROWN REGAL CENTRIK-LOK KC55 MEDIUM DUTY PILLOW BLOCK

MB KC55 Shaft Dia.	Browning MFS	Dodge SCM	SFK SYM-TM	Sealmaster MP MP-T
$1^{5/16}$ 1	316			15 16
$1^{9/16}$ ‡ $1^{1/4}$ S	319			19 20
$1^{7/16}$	323	$1^{7/16}$	$1^{7/16}$	23
$1^{1/2}$	324	$1^{1/2}$ †	$1^{1/2}$ †	24
$1^{11/16}$ $1^{3/4}$	327 328	$1^{11/16}$ † $1^{3/4}$ †	$1^{11/16}$ † $1^{3/4}$ †	27 28
$1^{15/16}$ 2	331 332	$1^{15/16}$ 2	$1^{15/16}$	31 32
$2^{3/16}$ $2^{1/4}$	335 336	$2^{3/16}$ $2^{1/4}$	$2^{3/16}$	35 36
$2^{7/16}$ $2^{1/2}$	339 340	$2^{7/16}$ $2^{1/2}$	$2^{7/16}$ $2^{1/2}$	39 40
$2^{11/16}$	343	$2^{11/16}$	$2^{11/16}$	43
$2^{15/16}$ 3	347 348	$2^{15/16}$ 3	$2^{15/16}$ 3	47 48
$3^{3/16}$ $3^{7/16}$ $3^{1/2}$	355 356	$3^{7/16}$ $3^{1/2}$	$3^{7/16}$ $3^{1/2}$	51 55 56

‡Not always available from stock. Consult Rexnord Bearing Products for availability.

† Denotes variation in shaft center height distance.

## 2-BOLT FLANGE UNIT COMPARISON CHART

The competitive manufacturers are listed in alphabetical order to provide a convenient source of unit substitution. This data is based on the two most important dimensions-bolt hole size and bolt hole spacing. This does not mean these competitive units are interchangeable in all respects. The bearings can be considered interchangeable in most instances, but should be checked if complete dimensional interchangeability is essential.

### KROWN REGAL CENTRIK-LOK KFC245 STANDARD DUTY FLANGE UNITS

MB KFC245 (Wide) FC225K (Narrow) Shaft Dia.	Link-Belt FX3U FX3Y	Browning MF2S MF2E	Dodge SC SXR	Fafnir RCJTC RCJT	SKF FYT-TM FYT-WM	Sealmaster SFT SFT-T
1/2	2B08	208	1/2	1/2	1/2	8
± <sup>9</sup> / <sub>16</sub>	210	210	5/8	<sup>9</sup> / <sub>16</sub>	5/8	9
<sup>5</sup> / <sub>8</sub>	211			<sup>11</sup> / <sub>16</sub>		10
<sup>11</sup> / <sub>16</sub>						11
<sup>3</sup> / <sub>4</sub>	212	212	<sup>3</sup> / <sub>4</sub>	<sup>3</sup> / <sub>4</sub>	<sup>3</sup> / <sub>4</sub>	12
± <sup>13</sup> / <sub>16</sub>						
± <sup>13</sup> / <sub>16</sub> L	214	214	<sup>7</sup> / <sub>8</sub>	<sup>13</sup> / <sub>16</sub>	<sup>13</sup> / <sub>16</sub>	13
<sup>7</sup> / <sub>8</sub>	215	215	<sup>15</sup> / <sub>16</sub>	<sup>7</sup> / <sub>8</sub>	<sup>7</sup> / <sub>8</sub>	14
<sup>15</sup> / <sub>16</sub>	216	216	1	<sup>15</sup> / <sub>16</sub>	<sup>15</sup> / <sub>16</sub>	15
1				1	1	16
± <sup>11</sup> / <sub>16</sub>	218	218	<sup>11</sup> / <sub>16</sub>	<sup>11</sup> / <sub>16</sub>	<sup>11</sup> / <sub>16</sub>	17
<sup>11</sup> / <sub>8</sub>	219	219	<sup>11</sup> / <sub>8</sub>	<sup>11</sup> / <sub>8</sub>	<sup>11</sup> / <sub>8</sub>	18
<sup>13</sup> / <sub>16</sub>	2E20	220S	<sup>13</sup> / <sub>16</sub>	<sup>13</sup> / <sub>16</sub>	<sup>13</sup> / <sub>16</sub>	19
<sup>11</sup> / <sub>4</sub> S			1 <sup>1</sup> / <sub>4</sub> (206)	1 <sup>1</sup> / <sub>4</sub> S	1 <sup>1</sup> / <sub>4</sub> A	20R
1 <sup>1</sup> / <sub>4</sub>	220	220	1 <sup>1</sup> / <sub>4</sub> (207)	1 <sup>1</sup> / <sub>4</sub>	1 <sup>1</sup> / <sub>4</sub>	20
<sup>15</sup> / <sub>16</sub>	221		<sup>15</sup> / <sub>16</sub>	<sup>15</sup> / <sub>16</sub>	<sup>15</sup> / <sub>16</sub>	21
<sup>13</sup> / <sub>8</sub>	222	222	<sup>13</sup> / <sub>8</sub>	<sup>13</sup> / <sub>8</sub>	<sup>13</sup> / <sub>8</sub>	22
<sup>17</sup> / <sub>16</sub>	223	223	<sup>17</sup> / <sub>16</sub>	<sup>17</sup> / <sub>16</sub>	<sup>17</sup> / <sub>16</sub>	23
1 <sup>1</sup> / <sub>2</sub>	224	224	1 <sup>1</sup> / <sub>2</sub>	1 <sup>1</sup> / <sub>2</sub>	1 <sup>1</sup> / <sub>2</sub>	24
± <sup>19</sup> / <sub>16</sub>				<sup>19</sup> / <sub>16</sub>		25
<sup>15</sup> / <sub>8</sub>			SC1 <sup>5</sup> / <sub>8</sub>			
± <sup>5</sup> / <sub>8</sub> L	226	226	SXR1 <sup>5</sup> / <sub>8</sub>	<sup>5</sup> / <sub>8</sub>	<sup>5</sup> / <sub>8</sub>	26
<sup>11</sup> / <sub>16</sub>	227	227	<sup>11</sup> / <sub>16</sub>	<sup>11</sup> / <sub>16</sub>	<sup>11</sup> / <sub>16</sub>	27
<sup>13</sup> / <sub>4</sub>	228	228	<sup>13</sup> / <sub>4</sub>	<sup>13</sup> / <sub>4</sub>	<sup>13</sup> / <sub>4</sub>	28
± <sup>13</sup> / <sub>16</sub>						
± <sup>13</sup> / <sub>16</sub> L				<sup>13</sup> / <sub>16</sub>		29
<sup>17</sup> / <sub>8</sub>				<sup>17</sup> / <sub>8</sub>		30
<sup>15</sup> / <sub>16</sub>	231	231	1 <sup>15</sup> / <sub>16</sub>	1 <sup>15</sup> / <sub>16</sub>	1 <sup>15</sup> / <sub>16</sub>	31
2	2E32		2			32R
2 L	232	232		2	2	32
± <sup>21</sup> / <sub>16</sub>				<sup>21</sup> / <sub>16</sub>		
<sup>21</sup> / <sub>8</sub>				<sup>21</sup> / <sub>8</sub>		
<sup>23</sup> / <sub>16</sub>	235	235		<sup>23</sup> / <sub>16</sub>	<sup>23</sup> / <sub>16</sub>	34
<sup>21</sup> / <sub>4</sub>						35

‡Not always available from stock. Consult Rexnord Bearing Products for availability.

### KROWN REGAL CENTRIK-LOK KFC255 MEDIUM DUTY FLANGE UNITS

MB KFC255 (Wide) FC235K (Narrow) Shaft Dia.	Dodge SCM	SFK FYTM-TM	Sealmaster MSFT MSFT-T
<sup>15</sup> / <sub>16</sub>			15
1			16
<sup>13</sup> / <sub>16</sub>			19
± <sup>11</sup> / <sub>4</sub> S			20
<sup>17</sup> / <sub>16</sub>	<sup>17</sup> / <sub>16</sub>	<sup>17</sup> / <sub>16</sub>	23
1 <sup>1</sup> / <sub>2</sub>	1 <sup>1</sup> / <sub>2</sub>	1 <sup>1</sup> / <sub>2</sub>	24
<sup>11</sup> / <sub>16</sub>	<sup>11</sup> / <sub>16</sub>	<sup>11</sup> / <sub>16</sub>	27
<sup>13</sup> / <sub>4</sub>	<sup>13</sup> / <sub>4</sub>	<sup>13</sup> / <sub>4</sub>	28
<sup>15</sup> / <sub>16</sub>		<sup>15</sup> / <sub>16</sub>	31
2			32

‡Not always available from stock. Consult Rexnord Bearing Products for availability.

## 4-BOLT FLANGE UNIT COMPARISON CHART

The competitive manufacturers are listed in alphabetical order to provide a convenient source of unit substitution. This data is based on the two most important dimensions-bolt hole size and bolt hole spacing. This does not mean these competitive units are interchangeable in all respects. The bearings can be considered interchangeable in most instances, but should be checked if complete dimensional interchangeability is essential.

### KROWN REGAL CENTRIK-LOK KFC445 STANDARD DUTY FLANGE UNITS

MB KFC445 (Wide) FC425K (Narrow) Shaft Dia.	Link-Belt F3U F3Y	Browning MF4S MF4E	Dodge SC SXR	Fafnir RCJC RCJ	SKF TY-TM FY-WM	Sealmaster SF SF-T
1/2	2B08	208	1/2	1/2	1/2	8
±9/16	210	210	5/8	9/16	5/8	9
11/16	211			11/16		10
3/4	212	212	3/4	3/4	3/4	11
±13/16						12
±13/16 L	214	214	7/8	13/16	13/16	13
7/8	215	215	15/16	7/8	7/8	14
15/16	216	216	1	15/16	15/16	15
1				1	1	16
±11/16	218	218	11/16	11/16	11/16	17
11/8	219	219	11/8	11/8	11/8	18
13/16	2E20	220S	13/16	13/16	13/16	19
11/4 S			11/4 (206)	11/4 S	11/4 A	20R
11/4	220	220	11/4 (207)	11/4	11/4	20
15/16	221		15/16	15/16	15/16	21
13/8	222	222	13/8	13/8	13/8	22
17/16	223	223	17/16	17/16	17/16	23
11/2	224	224	11/2	11/2	11/2	24
±13/16				13/16		25
15/8			SC15/8			
±15/8 L	226	226	SXR15/8	15/8	15/8	26
111/16	227	227	111/16	111/16	111/16	27
13/4	228	228	13/4	13/4	13/4	28
±113/16						
±113/16 L				13/16		29
17/8				17/8		30
115/16	231	231	115/16	115/16	115/16	31
2	2E32		2			32R
2 L	232	232		2	2	32
±21/16				21/16		
21/8				21/8		34
23/16	235	235	23/16	23/16	23/16	35
21/4			SC21/4			
±21/4 L	236	236	SXR21/4	21/4	21/4	36
25/16				25/16		
23/8	239	239	27/16	23/8	27/16	38
27/16				27/16		39
±25/8						
±211/16	243	243		211/16	211/16	43
±23/4	244				23/4	
±213/16						
±27/8						
215/16	247	247	215/16	215/16	215/16	46
						47

‡Not always available from stock. Consult Rexnord Bearing Products for availability.

## 4-BOLT FLANGE UNIT COMPARISON CHART (cont)

The competitive manufacturers are listed in alphabetical order to provide a convenient source of unit substitution. This data is based on the two most important dimensions-bolt hole size and bolt hole spacing. This does not mean these competitive units are interchangeable in all respects. The bearings can be considered interchangeable in most instances, but should be checked if complete dimensional interchangeability is essential.

### KROWN REGAL CENTRIK-LOK KFC455 MEDIUM DUTY FLANGE UNITS

MB KFC455 (Wide) FC435K (Narrow) Shaft Dia.	Browning MF4S	Dodge SCM	SFK FYM-TM	Sealmaster MSF MSF-T
$1^{5/16}$ 1	316			15 16
$1^{3/16}$ ‡ $1^{1/4}$ S	319			19 20
$1^{7/16}$	323	$1^{7/16}$	$1^{7/16}$	23
$1^{1/2}$	324	$1^{1/2}$ †	$1^{1/2}$	24
$1^{11/16}$ $1^{3/4}$	327 328	$1^{11/16}$ † $1^{3/4}$ †	$1^{11/16}$ $1^{3/4}$	27 28
$1^{15/16}$ 2	331 332	$1^{15/16}$ 2	$1^{15/16}$	31 32
$2^{3/16}$ $2^{1/4}$	335 336	$2^{3/16}$ $2^{1/4}$	$2^{3/16}$	35 36
$2^{7/16}$ $2^{1/2}$	339 340	$2^{7/16}$ $2^{1/2}$	$2^{7/16}$ $2^{1/2}$	39 40
$2^{11/16}$	343	$2^{11/16}$	$2^{11/16}$	43
$2^{15/16}$ 3	347 348	$2^{15/16}$ 3	$2^{15/16}$ 3	47 48
$3^{3/16}$ $3^{7/16}$ $3^{1/2}$	355 356	$3^{7/16}$ $3^{1/2}$	$3^{7/16}$ $3^{1/2}$	51 55 56

‡Not always available from stock. Consult Rexnord Bearing Products for availability.



# KROWN REGAL CENTRIK-LOK



# MOUNTED BALL BEARINGS designed for long life and precision performance.

MB bearings provide design and performance features developed by decades of experience in supplying precision ball bearing inserts for other major mounted bearing manufacturers and complete mounted units to machinery and equipment manufacturers. They are priced competitively to bearings of comparable construction.

In addition to sound basic design and construction, special features minimize the three most common causes of premature bearing failure...loosening of bearings on rotating shafts, entrance of contaminants or loss of lubricant due to seal failure and insufficient housing strength.

Standard duty and medium duty foot-mounted pillow blocks, flange units, take-up blocks and hanger bearings cataloged in the following pages are available from stock. For other sizes, mountings or special requirements to fit your applications, please consult the Rexnord Bearing Products.



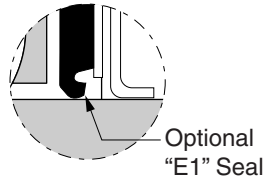
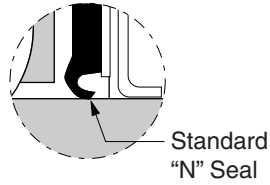
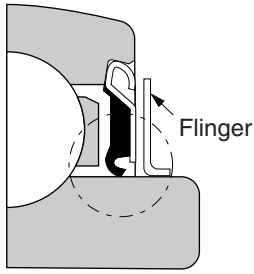

### Concentric setscrew shaft locking device

The MB method of fastening the bearing inner race to the shaft provides substantial improvement in holding power compared to eccentric locking collars and even greater improvement over 120 set screw positioning, over-collars and other types of locking arrangement.

### Combination seal-flinger system

Optimum protection from loss of lubricant and entrance of dirt and contaminants is achieved with positive lip-type contact seals. The resulting longer seal life extends bearing life significantly.

### Rugged, one-piece cast iron housing

Housings are designed to withstand bearing load ratings, external vibration and shock. Foot mounted pillow block bolt holes are elongated for easy installation and adjustment.

### Spherically-seated bearing insert with anti-rotation device

The spherical fit between the outer race O.D. and I.D. of the block is precisely controlled for easy shaft alignment. The anti-rotation device is permanently installed in the bearing insert O.D. It engages one of the housing insertion slots, preventing outer race creep and wear of housing. There is no danger of losing a separable pin during field replacement of bearings and no danger of preloading the bearing as is possible in other designs where a lube fitting is tightened against a locking pin.

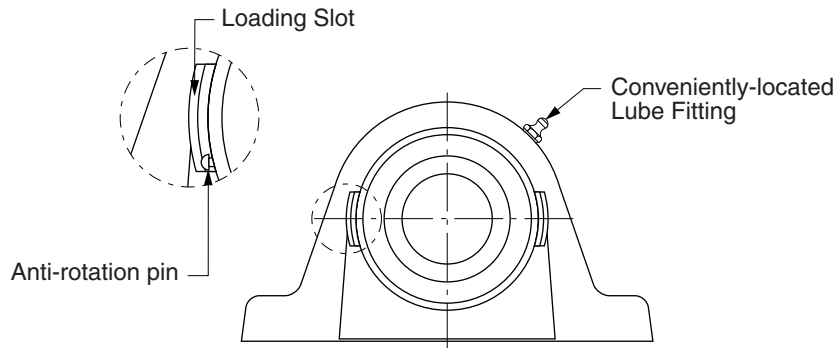
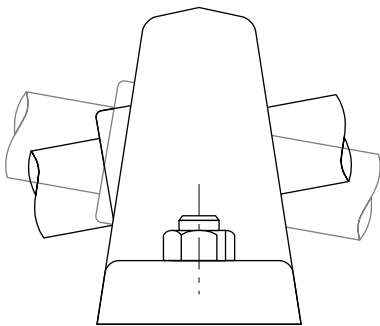

## PRECISION MOUNTED BALL BEARINGS with shafting locking device

MB concentric setscrew precision mounted ball bearings feature a concentric setscrew shaft locking device, resulting in a great improvement in the holding power (locking efficiency). Field experience shows substantial improvement in holding power when compared to eccentric locking collars and even greater improvement in locking efficiency when compared to 120° set screw positioning and other types of locking arrangements.

The locking set screws are located at a 90° angular relationship, rather than the traditional 120°.

A force diagram showing the 120° comparison of the locking characteristics of the old 120 set screw spacing and the 90° shaft locking device, superimposed on an end view of the inner ring, provides a more graphic illustration of the reason for the locking improvement. The force diagrams are arranged with an assumed 1,000 pound normal force between each of the set screws and the shaft. If each of these forces is resolved into its horizontal and vertical components, as shown in the view, it is seen that the effectiveness of the two horizontal components is lost because they cancel. The two vertical components are additive, resulting in a force between the shaft and the inner ring bore at the side opposite the bisector of the angle between the two set screws, equal to the sum of the two vertical components.

When the setscrew angle is at 90°, the horizontal and vertical load vectors are equalized. This optimization provides sufficient holding power to the shaft seat while controlling ring distortion. The results are a bearing that operated smoothly while achieving prolong shaft seat mounting tightness.

The positioning of the set screws has the further advantage of simplifying the set screw locking procedure. Rather than having to rotate the shaft (and other heavy components attached to it) through a large angle to alternatively tighten the set screws, the 90° locking device requires little or no movement of the shaft, to insure proper tightening. This is especially valuable where surrounding installation components limit maneuverability. In this type of application it can save installation time as well as assuring proper assembly.

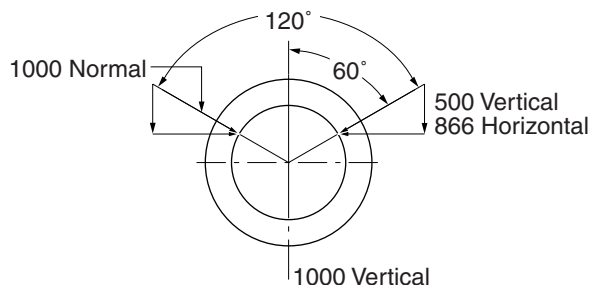

**120° Setscrew Spacing**

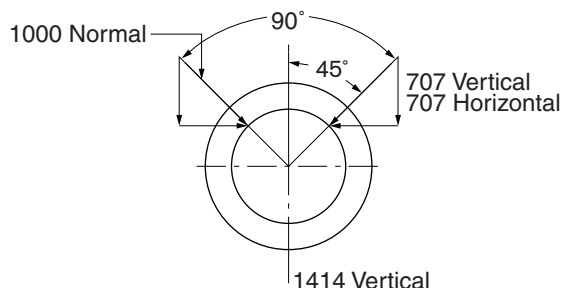

**90° Setscrew Spacing**



## MOUNTED BALL BEARINGS – LOAD RATINGS

Basic size	Co Static load rating		C Basic load rating		Approximate speed limit RPM*			d Ball diameter inches	N Number of balls	Nd <sup>2</sup>
	Newton's	pounds	Newton's	pounds	N seals	E,E1 seals	Flingers only			
203	4940	1110	8100	1820	14000	9000	15800	19/64	7	0.617
204	6590	1480	9830	2210	10000	7500	13400	5/16	8	0.781
205	7830	1760	10810	2430	9600	6800	11400	5/16	9	0.879
206	11300	2530	15030	3380	8000	5600	9800	3/8	9	1.27
207	15300	3440	19880	4470	6850	4800	8400	7/16	9	1.72
208	19900	4460	25100	5640	6000	4500	7500	1/2	9	2.25
209	20400	4590	25220	5670	5330	4000	6800	1/2	9	2.25
210	23200	5220	27090	6090	4800	3600	6400	1/2	10	2.50
211	29200	6570	33540	7540	4360	3200	5800	9/16	10	3.16
212	36000	8080	40520	9110	4000	3000	5300	5/8	10	3.91
					K seals	TFF seals	Flingers only			
214	38300	8620	48000	10800	3050	2850	4600	11/16	10	4.73
215	37600	8460	47600	10700	2900	2700	4400	11/16	10	4.73
216	50700	11400	59600	13400	2700	2550	4050	3/4	11	6.19
218	64000	14400	73800	16600	2400	2250	3600	7/8	10	7.66

If the load is greater than .15C for 25/35 series or .25C for all others, consult Rexnord Bearing Products.

\* Approximate speed limits are based on grease lubrication and moderate load.

# MOUNTED BALL BEARINGS – LOAD RATINGS

Basic Bearing	L <sub>10</sub> Minimum Life, Hours	RADIAL LOAD RATINGS IN POUNDS AT VARIOUS REVOLUTIONS PER MINUTE																				
		50	100	200	300	400	500	600	700	800	900	1000	1200	1500	1600	1800	2000	2500	3000	3500	4000	5000
203	3000	-	-	-	-	438	407	383	363	347	334	322	303	282	275	265	255	237	223	212	203	188
	8000	-	-	398	347	315	293	276	262	251	241	233	219	203	198	191	184	171	161	152	146	135
	20000	-	369	293	256	233	216	203	193	184	178	171	161	150	146	141	135	126	118	113	107	100
	40000	369	293	233	203	184	171	161	152	146	141	135	128	118	115	112	107	100	94	89	85	79
	100000	272	216	171	150	135	126	118	113	108	104	100	94	87	85	82	79	73	69	65	63	58
204	3000	-	-	-	-	532	494	465	441	422	406	391	368	342	334	322	310	288	271	257	246	229
	8000	-	-	483	422	383	356	335	318	304	293	282	266	247	241	232	224	208	195	185	178	164
	20000	-	449	356	311	282	262	247	234	224	216	208	195	182	178	171	164	153	144	137	130	121
	40000	449	356	282	247	224	208	195	185	178	171	164	155	144	140	136	130	121	114	108	104	96
	100000	330	262	208	182	164	153	144	137	131	126	122	114	106	104	100	96	89	84	80	76	71
205	3000	-	-	-	-	585	543	511	485	464	446	430	405	376	368	354	341	317	298	283	271	251
	8000	-	-	531	464	421	391	368	350	335	322	311	292	271	265	255	246	229	215	204	195	181
	20000	-	493	391	342	311	288	271	258	246	238	229	215	200	195	188	181	168	158	150	143	133
	40000	493	391	311	271	246	229	215	204	195	188	181	171	158	154	150	143	133	125	119	114	106
	100000	363	288	229	200	181	168	158	150	144	138	134	125	117	114	110	106	98	92	88	84	78
206	3000	-	-	-	-	814	756	711	674	646	621	599	564	524	512	492	475	441	415	394	377	350
	8000	-	-	739	646	586	545	512	487	466	448	432	407	378	368	355	342	318	299	284	272	252
	20000	-	686	545	476	432	401	378	359	343	331	318	299	279	272	262	252	234	220	209	200	185
	40000	686	545	432	378	343	318	299	284	272	262	252	238	220	215	208	200	185	175	166	159	147
	100000	505	401	318	279	252	234	220	209	201	193	186	175	163	159	153	147	136	129	122	117	108
207	3000	-	-	-	-	1070	1000	941	892	854	821	792	746	693	677	651	628	583	549	521	498	463
	8000	-	-	978	854	776	720	678	644	616	592	572	538	500	487	470	453	421	395	375	360	333
	20000	-	908	720	629	572	530	500	475	454	438	421	395	369	360	346	333	310	292	277	264	245
	40000	908	720	572	500	454	421	395	375	360	346	333	314	292	284	275	264	245	231	220	210	195
	100000	669	530	421	369	333	310	292	277	266	255	246	231	215	210	203	195	180	170	161	155	143
208	3000	-	-	-	-	1350	1260	1180	1120	1070	1030	1000	941	874	854	822	793	736	692	658	629	584
	8000	-	-	1230	1070	979	909	855	812	777	748	722	679	630	615	593	572	532	499	473	454	420
	20000	-	1140	909	794	722	669	630	599	573	552	532	499	466	454	437	420	391	368	350	333	309
	40000	1140	909	722	630	573	532	499	473	454	437	420	397	368	359	348	333	309	292	277	266	246
	100000	844	669	532	466	420	391	368	350	335	322	311	292	272	266	256	246	228	215	204	195	181
209	3000	-	-	-	-	1360	1260	1190	1130	1080	1040	1000	946	879	859	826	797	740	696	661	632	587
	8000	-	-	1240	1080	984	914	860	817	782	751	725	683	634	618	596	575	534	501	476	457	423
	20000	-	1150	914	798	725	673	634	602	576	555	534	501	468	457	439	423	393	370	352	335	311
	40000	1150	914	725	634	576	534	501	476	457	439	423	399	370	361	350	335	311	293	279	267	247
	100000	848	673	534	468	423	393	370	352	337	324	313	293	273	267	257	247	229	216	205	196	182
210	3000	-	-	-	-	1460	1360	1280	1210	1160	1110	1070	1010	944	922	887	856	795	748	710	679	
	8000	-	-	1330	1160	1050	982	924	877	840	807	779	733	681	664	641	617	574	538	511	491	
	20000	-	1230	982	857	779	723	681	647	618	597	574	538	503	491	472	454	422	398	378	360	
	40000	1230	982	779	681	618	574	538	511	491	472	454	428	398	387	375	360	334	315	300	287	
	100000	911	723	574	503	454	422	398	378	362	348	336	315	294	287	276	265	246	232	220	211	
211	3000	-	-	-	-	1810	1680	1580	1500	1440	1380	1330	1250	1160	1140	1090	1060	984	926	879	841	
	8000	-	-	1640	1440	1300	1210	1140	1080	1040	1000	965	908	843	823	793	764	711	667	633	608	
	20000	-	1530	1210	1060	965	895	843	801	766	739	711	667	623	608	584	562	523	492	468	446	
	40000	1530	1210	965	843	766	711	667	633	608	584	562	530	492	480	465	446	414	390	371	355	
	100000	1120	895	711	623	562	523	492	468	448	430	416	390	364	355	342	329	305	287	273	261	
212	3000	-	-	-	-	2190	2030	1910	1810	1740	1670	1610	1520	1410	1380	1320	1280	1180	1110	1060	1010	
	8000	-	-	1990	1740	1580	1460	1380	1310	1250	1200	1160	1090	1010	994	958	923	859	806	765	734	
	20000	-	1850	1460	1280	1160	1080	1010	968	925	893	859	806	752	734	706	679	632	595	565	539	
	40000	1850	1460	1160	1010	925	859	806	765	734	706	679	641	595	580	562	539	500	472	448	429	
	100000	1360	1080	859	752	679	632	595	565	542	520	503	472	440	429	414	397	368	347	330	316	
214	3000	-	-	-	-	2600	2410	2270	2150	2060	1980	1910	1800	1670	1630	1570	1510	1400	1320			
	8000	-	-	2360	2060	1870	1740	1630	1550	1480	1430	1380	1300	1200	1170	1130	1090	1010	955			
	20000	-	2190	1740	1520	1380	1280	1200	1140	1090	1050	1010	955	892	870	837	805	750	705			
	40000	2190	1740	1380	1200	1090	1010	955	907	870	837	805	760	705	687	666	639	593	559			
	100000	1610	1280	1010	892	805	750	705	670	642	617	596	559	521	509	490	471	437	412			
215	3000	-	-	-	-	2570	2390	2250	2130	2040	1960	1890	1780	1650	1620	1550	1500	1390				
	8000	-	-	2340	2040	1850	1720	1620	1540	1470	1410	1370	1280	1190	1160	1120	1080	1000				
	20000	-	2170	1720	1500	1370	1270	1190	1130	1080	1040	1000	946	884	862	829	798	743				
	40000	2170	1720	1370	1190	1080	1000	946	899	862	829	798	753	699	681	660	633	587				
	100000	1600	1270	1000	884	798	743	699	664	636	611	591	554	516	504	486	467	433				
216	3000	-	-	-	-	3220	2990	2820	2670	2560	2460	2370	2230	2070	2030	1950	1880	1740				
	8000	-	-	2930	2560	2320	2160	2030	1930	1840	1770	1710	1610	1490	1460	1410	1350	1260				
	20000	-	2720	2160	1880	1710	1590	1490	1420	1360	1310	1260	1180	1100	1080	1030	1000	930				
	40000	2720	2160	1710	1490	1360	1260	1180	1120	1080	1030	1000	943	875	853	827	792	736				
	100000	2000	1590	1260	1100	1000	930	875	832	797	765	740	694	647	632	609	585	542				
218	3000	-	-	-	-	4000	3710	3490	3310	3170	3050	2940	2770	2570	2510	2410	2330					
	8000	-	-	3630	3170	2880	2670	2510	2390	2280	2200	2120	20									

## Standard sealing arrangements

Standard steel clad Type N single lip seals have a useful temperature range of  $-40^{\circ}\text{F}$  to  $+225^{\circ}\text{F}$  and can withstand temperatures of  $250^{\circ}\text{F}$  for intermittent service. Special sealing arrangements are available for higher temperatures and “free-running” or special contamination resistance.

## Special optional sealing arrangements

Suffix-MHFF indicates flingers both sides. This provides a sealed, “free-running” bearing with heat shield protection. It is satisfactory for temperatures from  $-40^{\circ}\text{F}$  to  $+225^{\circ}\text{F}$ .

Rexnord Bearing Products *must* be consulted regarding availability of any of these optional sealing configurations.

Examples for ordering:

1. Bearing Insert MB251-716-MHFFPA
2. Mounted Unit C251-716-MHFF

## High temperatures ball bearing inserts and housed units

Mounted ball bearings and MB25, MB35 and ER series inserts are available for high temperature applications up to  $400^{\circ}\text{F}$ . The “E1” package provides the following features.

1. Extra Internal Diametral Clearance (DC) based on a  $200^{\circ}\text{F}$  temperature differential between inner and outer races, compensates for the inner race expanding at a faster rate than the outer race and will avoid preloading of the bearings.
2. Steel Retainer (Cage) – 2 piece riveted construction.
3. High Temperature Lubrication – prelubricated with a No. 2 consistency bentone-base grease with petroleum oil. When operated near upper limit, ( $400^{\circ}\text{F}$  to  $450^{\circ}\text{F}$ ) daily relubrication is required.
4. Viton Seals withstand temperatures to  $400^{\circ}\text{F}$ .

Examples for ordering:

1. Bearing Insert MB251-716-E1PA
2. Mounted Unit C251-716-E1

## Free running applications and applications above $400^{\circ}\text{F}$

Sealing options such as -FF (flingers only) for “free running” applications and/or temperatures over  $400^{\circ}\text{F}$  where contamination is not severe. The flinger acts as a labyrinth seal. High temperature bearings require a greater amount of diametral clearance (DC) and a higher temperature lubricant. Consult Rexnord Bearing Products for recommendations. Consult your MB bearing source for price and availability of any special features.

Examples for ordering:

1. Bearing Insert MB251-716-FFPA
2. Mounted Unit C251-716-FF

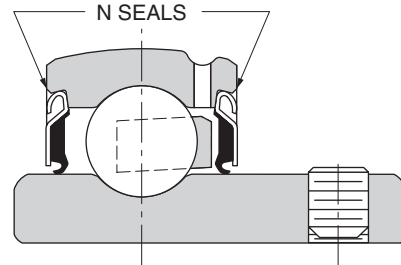

### BASIC MB25/35 SEALS

214 thru 218 Basic Sizes have Nyla-K seals and Flingers

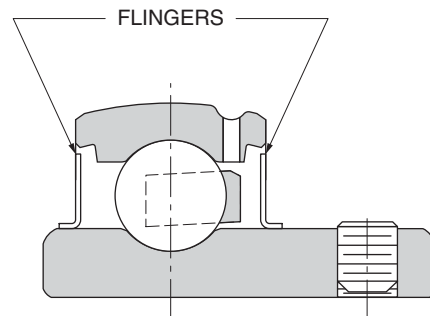

### -MHFF

214 thru 218 Basic Sizes have Modified Nyla-K seals and Flingers use suffix MKFF

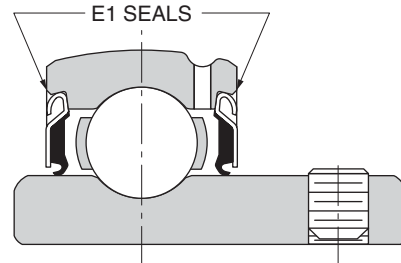

### -E1

214 thru 218 Basic Sizes have Viton seals and Flingers use suffix TFF

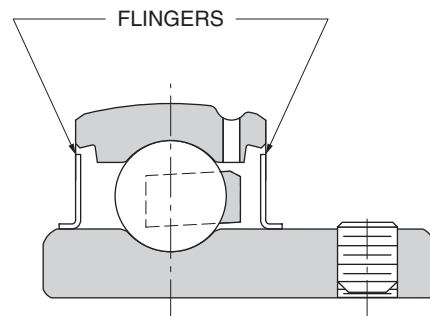

### -FF

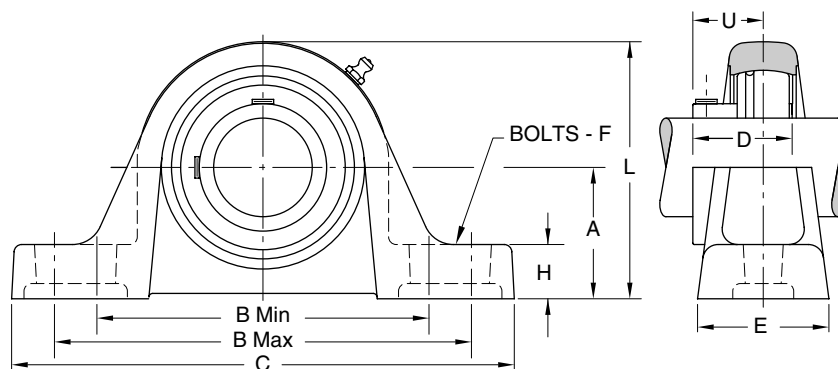

## STANDARD DUTY PILLOW BLOCKS with low shaft height

Elongated bolt holes allow adjustment to facilitate mounting as well as alignment.

Shaft Diameter mm	Inches	Pillow Block Number	Basic Size	A †	B		C	D	E	F Bolts	H	L	U	Unit Wt. (lbs/kg)	Bearing Number
					Min.	Max.									
17	1/2	CL25-12 CL25-58 CL25-1116	203	1 1/16	3 1/8	4 1/8	5	63/64	1 5/16	3/8	3/8	2 5/32	4 1/64	1.06	MB25-12-PA MB25-58-PA MB25-1116-PA
	5/8			26.97	79.4	104.8	127.0	24.99	33.32	10	9.5	54.8	16.3	1.02	
20	3/4	CL25-34 CL25-20	204	1 1/4	3 3/8	4 3/16	5 1/4	1 1/8	1 7/16	3/8	15/32	2 15/32	3/4	1.44	MB25-34-PA MB25-20-PA
	11/16			31.75	85.7	106.4	133.3	28.58	36.52	10	11.9	62.7	19.0	0.6	
25	7/8	CL25-78 CL25-1516 CL251 CL25-25	205	1 5/16	3 7/16	4 9/16	5 1/2	1 11/64	1 7/16	3/8	15/32	2 11/16	5 1/64	1.71	MB25-78-PA MB25-1516-PA MB251-PA MB25-25-PA
	15/16			33.32	87.3	115.9	132.1	29.77	36.52	10	11.9	68.3	20.2	1.68	
30	1 1/8	CL251-18 CL251-316 CL251-14S CL25-30	206	1 9/16	4 1/8	5 1/8	6 1/4	1 11/32	1 5/8	1/2	17/32	3 1/8	6 1/64	2.27	MB251-18-PA MB251-316-PA MB251-14S-PA MB25-30-PA
	1 3/16			39.67	104.8	130.2	158.8	34.14	41.28	12	13.5	79.38	24.2	2.24	
35	1 1/4	CL251-14 CL251-38 CL251-716 CL25-35	207	1 13/16	4 9/16	5 9/16	6 11/16	1 9/16	1 3/4	1/2	11/16	3 5/8	1 7/64	3.47	MB251-14-PA MB251-38-PA MB251-716-PA MB25-35-PA
	1 3/8			46.02	115.9	141.3	169.9	39.67	44.45	12	17.5	92.08	28.2	3.37	
40	1 1/2	CL251-12 CL251-58 CL25-40	208	1 15/16	5 1/32	6 1/32	7 1/4	1 21/32	1 7/8	1/2	11/16	3 15/16	1 11/64	4.54	MB251-12-PA MB251-58-PA MB25-40-PA
	1 5/8			49.22	127.8	153.2	184.2	42.06	47.62	12	17.5	100.02	29.8	4.40	
45	1 5/8	CL251-58L CL251-1116 CL251-34	209	2 1/16	5 13/32	6 17/32	7 3/4	1 49/64	2	1/2	27/32	4 3/16	1 15/64	5.22	MB251-58L-PA MB251-1116-PA MB251-34-PA
	1 11/16			52.37	137.3	165.9	196.8	44.86	50.80	12	21.4	106.38	31.3	5.15	
50	1 7/8	CL251-78 CL251-1516 CL252	210	2 3/16	5 27/32	6 27/32	8 1/4	1 13/16	2 1/8	5/8	15/16	4 7/16	1 17/64	6.15	MB251-78-PA MB251-1516-PA MB252-PA
	1 15/16			55.58	148.4	173.8	209.6	46.02	53.98	16	23.8	112.72	32.2	6.06	
55	2	CL252L CL252-316 CL252-14	211	2 7/16	6 5/16	7 1/2	8 7/8	1 13/16	2 5/16	5/8	15/16	4 29/32	1 9/32	7.61	MB252L-PA MB252-316-PA MB252-14-PA
	2 3/16			61.92	160.3	190.5	225.4	46.02	58.72	16	23.8	124.61	32.5	7.31	
60	2 1/4	CL252-14L CL252-38 CL252-716	212	2 11/16	6 29/32	8 5/32	9 5/8	1 57/64	2 3/8	5/8	1	5 13/32	1 5/16	10.07	MB252-14L-PA MB252-38-PA MB252-716-PA
	2 3/8			68.28	175.4	207.2	244.5	48.03	60.32	16	25.4	137.31	33.3	9.83	
75	2 15/16	CL252-1516	215	3 5/16	8 1/8	10 1/8	12	2 17/64	2 7/8	7/8	1 1/32	6 15/32	1 15/32	16.23	MB252-1516-PA
				84.12	206.4	257.2	304.8	57.56	73.02	24	26.2	164.31	37.3	7.4	

Lubrication fitting tap size; 203 thru 205 basic size, 1/4"-28UNF, 206 thru 215 basic size, 1/8" PT

†Tolerance, ±.005" (±0.13mm)

Selection Guide – pages 4-6 & 37-39

Load Ratings – pages 40-41

Additional Information – page 42

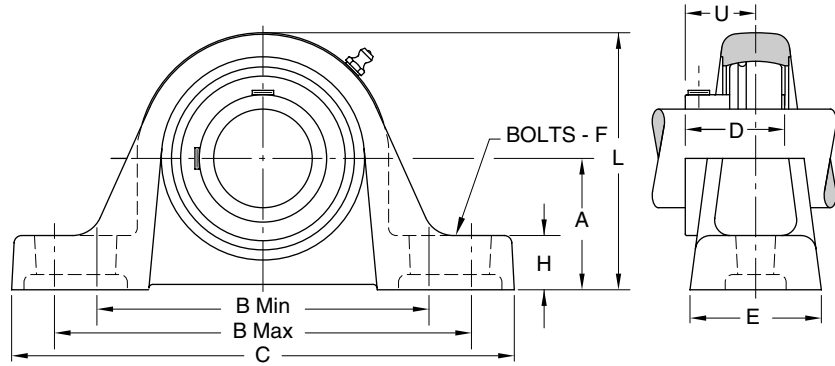

## STANDARD DUTY PILLOW BLOCKS

Elongated bolt holes allow adjustment to facilitate mounting as well as alignment.

Shaft Dia.		Pillow Block Number	Basic Size	A †	B		C	D	E	F Bolts	H	L	U	Unit wt. (lbs/kg)	Bearing Number	
mm	Inches				Min.	Max.										
17	1/2 5/8 11/16	C25-12	203	1 3/16	3 1/8	4 1/8	5	63/64	1 5/16	3/8	1/2	2 9/32	41/64	1.11	MB25-12-PA	
		C25-58														1.07
		C25-1116														1.05
20	3/4	C25-34	204	1 5/16	3 3/8	4 3/16	5 1/4	1 1/8	1 7/16	3/8	17/32	2 17/32	3/4	1.51	MB25-34-PA	
		C25-20														0.7
																19.0
25	7/8 15/16 1	C25-78	205	1 7/16	3 7/16	4 9/16	5 1/2	1 11/64	1 7/16	3/8	19/32	2 13/16	51/64	1.81	MB25-78-PA	
		C25-1516														1.78
		C251 C25-25														1.75 0.8
30	1 1/8 1 3/16 1 1/4	C251-18	206	1 11/16	4 1/8	5 1/8	6 1/4	1 11/32	1 5/8	1/2	21/32	3 1/4	61/64	2.45	MB251-18-PA	
		C251-316														2.42
		C251-14S C25-30														2.39 1.1
35	1 1/4 1 3/8 1 7/16	C251-14	207	1 7/8	4 9/16	5 9/16	6 11/16	1 9/16	1 3/4	1/2	3/4	3 11/16	1 7/64	3.57	MB251-14-PA	
		C251-38														3.47
		C251-716 C25-35														3.41 1.6
40	1 1/2 1 5/8	C251-12	208	2 1/8	5 1/32	6 1/32	7 1/4	1 21/32	1 7/8	1/2	7/8	4 1/8	1 11/64	4.60	MB251-12-PA	
		C251-58														4.46
		C25-40														2.0
45	1 5/8 1 11/16 1 3/4	C251-58L	209	2 1/8	5 13/32	6 17/32	7 3/4	1 49/64	2	1/2	29/32	4 1/4	1 15/64	5.28	MB251-58L-PA	
		C251-1116														5.21
		C251-34														5.14 2.3
50	1 7/8 1 15/16 2	C251-78	210	2 1/4	5 27/32	6 27/32	8 1/4	1 13/16	2 1/8	5/8	1	4 1/2	1 17/64	6.28	MB251-78-PA	
		C251-1516														6.19
		C252														6.10 2.8
55	2 2 3/16 2 1/4	C252L	211	2 1/2	6 5/16	7 1/2	8 7/8	1 13/16	2 5/16	5/8	1	4 31/32	1 9/32	7.78	MB252L-PA	
		C252-316														7.48
		C252-14														7.38 3.3
60	2 1/4 2 3/8 2 7/16	C252-14L	212	2 3/4	6 29/32	8 5/32	9 5/8	1 57/64	2 3/8	5/8	1 1/16	5 15/32	1 5/16	10.12	MB252-14L-PA	
		C252-38														9.88
		C252-716														9.76 4.4
75	2 15/16	C252-1516	215	3 1/2	8 1/8	10 1/8	12	2 17/64	2 7/8	7/8	1 7/32	6 21/32	1 15/32	16.73	MB252-1516-PA	
				88.90	206.4	257.2	304.8	57.56	73.02	24	31.0	169.1	37.3	7.6		

Lubrication fitting tap size; 203 thru 205 basic size, 1/4"-28UNF, 206 thru 215 basic size, 1/8" PT  
†Tolerance, ±.005" (±0.13mm)

Selection Guide – pages 4-6 & 37-39

Load Ratings – pages 40-41

Additional Information – page 42

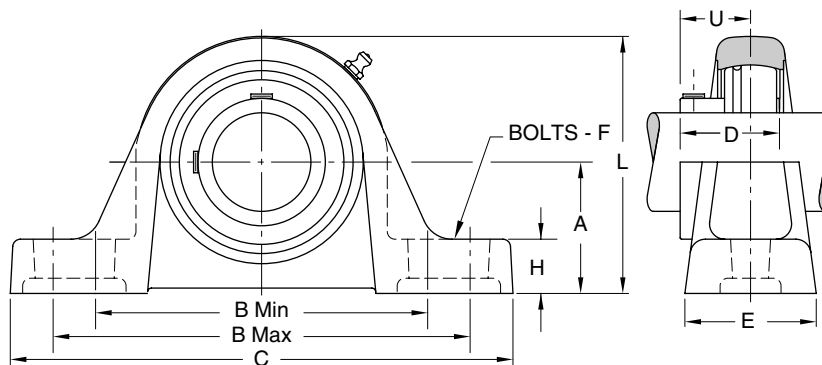

## MEDIUM DUTY PILLOW BLOCKS

Elongated bolt holes allow adjustment to facilitate mounting as well as alignment.

Shaft Dia. Inches	Pillow Block Number	Basic Size	A †	B		C	D	E	F Bolts	H	L	U	Unit Wt. (lbs/kg)	Bearing Number
				Min.	Max.									
1	C351	206	1 11/16 42.88	4 1/8 104.8	5 1/8 130.2	6 1/4 158.8	1 11/32 34.14	1 5/8 41.3	1/2 12	21/32 16.7	3 1/4 82.6	61/64 24.2	2.54 1.2	MB351-PA
1 3/16	C351-316	207	1 7/8 47.62	4 9/16 115.9	5 9/16 141.3	6 11/16 169.9	1 9/16 39.67	1 3/4 44.4	1/2 12	3/4 19.0	3 11/16 93.7	1 7/64 28.2	3.58 1.6	MB351-316-PA
1 7/16	C351-716	208	2 1/8 54.00	5 1/32 127.8	6 1/32 153.2	7 1/4 184.2	1 21/32 42.06	1 7/8 47.6	1/2 12	7/8 22.2	4 1/8 104.8	1 11/64 29.8	4.65 2.1	MB351-716-PA
1 1/2	C351-12	209	2 1/8 54.00	5 13/32 137.3	6 17/32 165.9	7 3/4 196.8	1 49/64 44.86	2 50.8	1/2 12	29/32 23.0	4 1/4 108.0	1 15/64 31.3	5.40 2.4	MB351-12-PA
1 11/16	C351-1116	210	2 1/4 57.15	5 27/32 148.4	6 27/32 173.8	8 1/4 209.6	1 13/16 46.02	2 1/8 54.0	5/8 16	1 25.4	4 1/2 114.3	1 17/64 32.2	6.53 3.0	MB351-1116-PA MB351-34-PA
1 3/4	C351-34													
1 15/16	C351-1516	211	2 1/2 63.50	6 5/16 160.3	7 1/2 190.5	8 7/8 225.4	1 13/16 46.02	2 5/16 58.7	5/8 16	1 25.4	4 31/32 126.2	1 9/32 32.5	7.87 3.6	MB351-1516-PA MB352-PA
2	C352													
2 3/16	C352-316	212	2 3/4 69.85	6 29/32 175.4	8 5/32 207.2	9 5/8 244.5	1 57/64 48.03	2 3/8 60.3	5/8 16	1 1/16 27.0	5 15/32 138.9	1 5/16 33.32	10.24 4.6	MB352-316-PA
2 7/16	C352-716	214	3 76.20	7 1/2 190.5	9 1/4 235.0	10 3/4 273.0	2 15/64 56.74	2 11/16 68.3	3/4 20	1 5/32 29.4	6 152.4	1 7/16 36.5	13.31 6.0	MB352-716-PA MB352-12-PA
2 1/2	C352-12													
2 11/16	C352-1116	215	3 1/2 88.90	8 1/8 206.4	10 1/8 257.2	12 304.8	2 17/64 57.56	2 7/8 73.0	7/8 24	1 7/32 31.0	6 21/32 169.1	1 15/32 37.3	17.36 7.9	MB352-1116-PA
2 15/16	C352-1516	216	3 1/2 88.90	8 3/8 225.4	10 1/8 257.2	12 304.8	2 23/64 59.92	3 76.2	7/8 24	1 9/32 32.5	6 7/8 174.6	1 1/2 38.1	19.32 8.8	MB352-1516-PA MB353-PA
3	C353													
3 3/16	C353-316	218	4 101.6	9 13/16 249.2	11 15/16 303.2	14 355.6	2 33/64 63.91	3 3/8 85.7	7/8 24	1 11/32 34.1	7 7/8 200.0	1 9/16 39.7	27.52 12.5	MB353-316-PA MB353-716-PA MB353-12-PA
3 7/16	C353-716													
3 1/2	C353-12													

Lubrication fitting tap size; 1/8" PT  
†Tolerance, ±.005" (±0.13mm)

Selection Guide – pages 4-6 & 37-39  
Load Ratings – pages 40-41  
Additional Information – page 42

The most popular mounted units are pillow blocks. Pillow blocks provide an integral unit to support shafts parallel to the mounting surface. The casting base has elongated holes for the mounting bolts to provide interchangeability with other competitive makes as well as ease of adjustment during installation. Self-aligning pillow block assemblies usually do not require shimming at the base because self-aligning of the bearing within the housing permits enough adjustment.

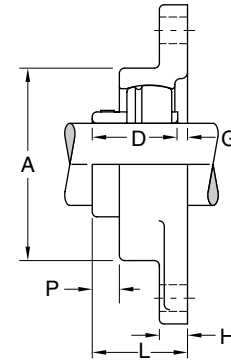
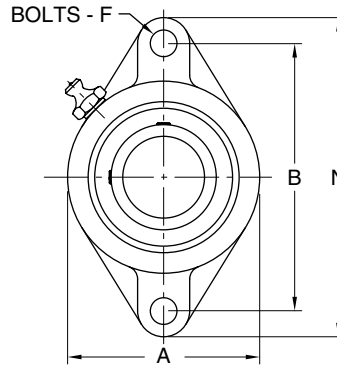

## 2-BOLT STANDARD DUTY FLANGE UNITS

These flange units incorporate the advantages of foot mounted pillow blocks, but are intended for surface mounting, vertical or horizontal, at right angles to the shaft. Bolt holes are spaced for interchangeability with mountings of similar designs.

Shaft Dia.		Flanged Unit Number	Basic Size	A	B	D	F Bolts	G	H	L	N	P	Unit Wt. (lbs/kg)	Bearing Number
mm	Inches													
17	1/2 5/8 11/16	FC225-12	203	2 5/16	3	63/64	3/8	9/64	3/8	1 1/8	3 7/8	5/16	0.81	MB25-12-PA MB25-58-PA MB25-1116-PA
		FC225-58		58.7	76.20	24.99	10	3.6	9.5	28.6	98.4	7.9	0.77	
		FC225-1116											0.75	
20	3/4	FC225-34	204	2 3/8	3 17/32	1 1/8	3/8	9/64	7/16	1 9/32	4 13/32	13/32	0.91	MB25-34-PA MB25-20-PA
		FC225-20		60.3	89.69	28.58	10	3.6	11.1	32.2	111.9	10.3	0.4	
25	7/8 15/16 1	FC225-78	205	2 3/4	3 57/64	1 11/64	7/16	1/8	1/2	1 5/16	4 7/8	7/16	1.32	MB25-78-PA MB25-1516-PA MB251-PA MB25-25-PA
		FC225-1516		69.8	98.82	29.77	10	3.2	12.7	33.3	123.8	11.1	1.29	
		FC2251											1.26	
30	1 1/8 1 3/16 1 1/4	FC2251-18	206	3 3/16	4 19/32	1 11/32	7/16	9/64	17/32	1 1/2	5 9/16	9/16	1.79	MB251-18-PA MB251-316-PA MB251-145-PA MB25-30-PA
		FC2251-316		81.0	116.68	34.14	10	3.6	13.5	38.1	141.3	14.3	1.71	
35	1 1/4 1 3/8 1 7/16	FC2251-14	207	3 11/16	5 1/8	1 9/16	1/2	9/64	9/16	1 23/32	6 1/8	21/32	2.69	MB251-14-PA MB251-38-PA MB251-716-PA MB25-35-PA
		FC2251-38		93.7	130.18	39.67	12	3.6	14.3	43.7	155.6	16.7	2.54	
40	1 1/2 1 5/8	FC2251-12	208	4 1/8	5 21/32	1 21/32	1/2	5/32	9/16	1 13/16	6 3/4	21/32	3.47	MB251-12-PA MB251-58-PA MB25-40-PA
		FC2251-58		104.8	143.67	42.06	12	4.0	14.3	46.0	171.4	16.7	3.33	
45	1 5/8 1 11/16 1 3/4	FC2251-58L	209	4 3/8	5 27/32	1 49/64	9/16	1/8	9/16	1 29/32	7 1/16	23/32	3.46	MB251-58L-PA MB251-1116-PA MB251-34-PA
		FC2251-1116		111.1	148.30	44.86	14	3.2	14.3	48.4	179.4	18.3	3.32	
50	1 7/8 1 15/16 2	FC2251-78	210	4 9/16	6 3/16	1 13/16	9/16	7/64	5/8	1 29/32	7 15/32	23/32	4.43	MB251-78-PA MB251-1516-PA MB252-PA
		FC2251-1516		115.9	157.16	46.02	14	2.8	15.9	48.4	189.7	18.3	4.34	
55	2 2 3/16 2 1/4	FC2252L	211	5	7 1/4	1 13/16	5/8	11/64	23/32	2	8 1/2	11/16	6.04	MB252L-PA MB252-316-PA MB252-14-PA
		FC2252-316		127.0	184.15	46.02	16	4.8	43.7	50.8	215.9	17.5	5.74	
		FC2252-14											5.64	
													2.6	

Lubrication fitting tap size; 203 thru 205 basic size, 1/4"-28UNF, 206 thru 211 basic size, 1/8" PT

Selection Guide – pages 4-6 & 37-39

Load Ratings – pages 40-41

Additional Information – page 42

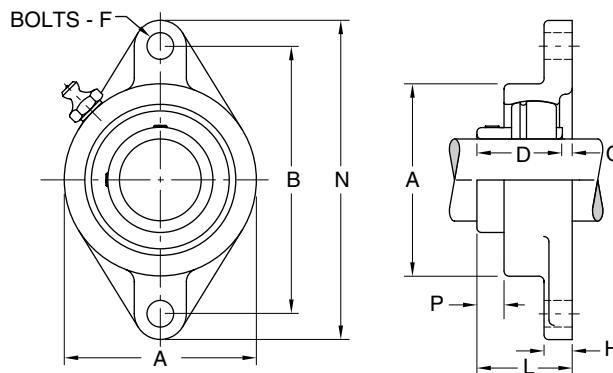

## 2-BOLT MEDIUM DUTY FLANGE UNITS

These flange units incorporate the advantages of foot mounted pillow blocks, but are intended for surface mounting, vertical or horizontal, at right angles to the shaft. Bolt holes are spaced for interchangeability with mountings of similar designs.

Shaft Dia. Inches	Flanged United Number	Basic Size	A	B Min.	C	D	E	F Bolts	H	L	U	Unit Wt. (lbs/kg)	Bearing Number
$1\frac{5}{16}$	<b>FC235-1516</b>	206	$3\frac{3}{16}$ 81.0	$4\frac{19}{32}$ 116.68	$1\frac{11}{32}$ 34.14	$\frac{7}{16}$ 10	$\frac{9}{64}$ 3.6	$\frac{17}{32}$ 13.5	$1\frac{1}{2}$ 38.1	$5\frac{9}{16}$ 141.3	$\frac{9}{16}$ 14.3	1.92 0.9	<b>MB35-1516-PA</b>
$1\frac{3}{16}$	<b>FC2351-316</b>	207	$3\frac{11}{16}$ 93.7	$5\frac{1}{8}$ 130.18	$1\frac{9}{16}$ 39.67	$\frac{1}{2}$ 12	$\frac{9}{64}$ 3.6	$\frac{9}{16}$ 14.3	$1\frac{23}{32}$ 43.7	$6\frac{1}{8}$ 155.6	$\frac{21}{32}$ 16.7	2.70 1.2	<b>MB351-316-PA</b>
$1\frac{7}{16}$	<b>FC2351-716</b>	208	$4\frac{1}{8}$ 104.8	$5\frac{21}{32}$ 143.67	$1\frac{21}{32}$ 42.06	$\frac{1}{2}$ 12	$\frac{5}{32}$ 4.0	$\frac{9}{16}$ 14.3	$1\frac{13}{16}$ 46.0	$6\frac{3}{4}$ 171.4	$\frac{21}{32}$ 16.7	3.52 1.6	<b>MB351-716-PA</b>
$1\frac{1}{2}$	<b>FC2351-12</b>	209	$4\frac{3}{8}$ 111.1	$5\frac{27}{32}$ 148.30	$1\frac{49}{64}$ 44.86	$\frac{9}{16}$ 14	$\frac{1}{8}$ 3.2	$\frac{9}{16}$ 14.3	$1\frac{29}{32}$ 48.4	$7\frac{1}{16}$ 179.4	$\frac{23}{32}$ 18.3	3.58 1.6	<b>MB351-12-PA</b>
$1\frac{11}{16}$	<b>FC2351-1116</b>	210	$4\frac{9}{16}$	$6\frac{3}{16}$	$1\frac{13}{16}$	$\frac{9}{16}$	$\frac{7}{64}$	$\frac{5}{8}$	$1\frac{29}{32}$	$7\frac{15}{32}$	$\frac{23}{32}$	4.67	<b>MB351-1116-PA</b>
$1\frac{3}{4}$	<b>FC2351-34</b>		115.9	157.16	46.02	14	2.8	15.9	48.4	189.7	18.3	2.1	<b>MB351-34-PA</b>
$1\frac{15}{16}$	<b>FC2351-1516</b>	211	5	$7\frac{1}{4}$	$1\frac{13}{16}$	$\frac{5}{8}$	$\frac{11}{64}$	$\frac{23}{32}$	2	$8\frac{1}{2}$	$\frac{11}{16}$	6.13	<b>MB351-1516-PA</b>
2	<b>FC2352</b>		127.0	184.15	46.02	16	4.8	43.7	50.8	215.9	17.5	2.8	<b>MB352-PA</b>

Lubrication fitting tap size;  $\frac{1}{8}$ " PT

Selection Guide – pages 4-6 & 37-39

Load Ratings – pages 40-41

Additional Information – page 42

2-Bolt flange units, like the foot mounted counterparts, are also provided with a grease fitting for relubrication purposes. The bolt hole size as well as spacing is interchangeable with other competitive units. Flange units are used in place of pillow blocks for side mounting without providing brackets or any other type of structure.

All MB flange units have been designed to maintain a minimum overall thickness with the smallest possible standoff dimension from the mounting face or back of flange to the outboard face of the inner race. This minimizes the necessity of extending shaft lengths and provides interchangeability with other competitive makes.



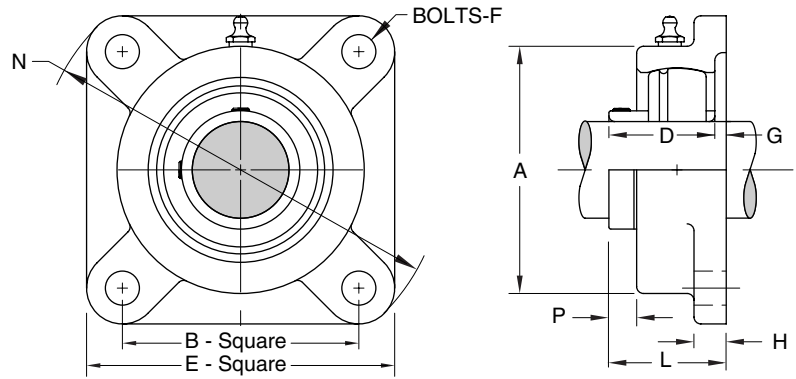

## 4-BOLT STANDARD DUTY FLANGE UNITS

These flange units incorporate the advantages of foot mounted pillow blocks, but are intended for surface mounting, vertical or horizontal, at right angles to the shaft. Bolt holes are spaced for interchangeability with mountings of similar designs.

Shaft Dia. mm	Inches	Flanged Unit Number	Basic Size	A	B	D	E	F Bolts	G	H	L	N	P	Unit Wt. (lbs/kg)	Bearing Number
17	1/2	FC425-12 FC425-58 FC425-1116	203	2 1/16	2 1/8	63/64	3	3/8	9/64	3/8	1 1/8	3 7/8	5/16	0.99	MB25-12-PA MB25-58-PA MB25-1116-PA
	5/8			52.4	53.98	24.99	76.2	10	3.6	9.5	28.6	98.4	7.9	0.95	
	11/16													0.93	
20	3/4	FC425-34 FC425-20	204	2 5/16	2 1/2	1 1/8	3 3/8	3/8	9/64	3/8	1 9/32	4 13/32	13/32	1.30	MB25-34-PA MB25-20-PA
				58.7	63.50	28.58	85.7	10	3.6	9.5	32.2	111.9	10.3	0.6	
25	7/8	FC425-78 FC425-1516 FC4251 FC425-25	205	2 11/16	2 3/4	1 11/64	3 3/4	7/16	1/8	7/16	1 5/16	4 29/32	7/16	1.71	MB25-78-PA MB25-1516-PA MB251-PA MB25-25-PA
	15/16			68.3	69.85	29.77	95.2	10	3.2	11.1	33.3	124.6	11.1	1.68	
	1														
30	1 1/8	FC4251-316 FC4251-14S FC425-25	206	3 3/16	3 1/4	1 11/32	4 1/4	7/16	9/64	1/2	1 1/2	5 19/32	9/16	2.50	MB251-18-PA MB251-316-PA MB251-14S-PA MB25-30-PA
	1 3/16			81.0	82.55	34.14	108.0	10	3.6	12.7	38.1	142.1	14.3	2.46	
	1 1/4														
35	1 1/4	FC4251-14 FC4251-38 FC4251-716 FC425-35	207	3 11/16	3 5/8	1 9/16	4 5/8	1/2	9/64	1/2	1 23/32	6 1/8	21/32	3.41	MB251-14-PA MB251-38-PA MB251-716-PA MB25-35-PA
	1 3/8			93.7	92.08	39.67	117.5	12	3.6	12.7	43.7	155.6	16.7	3.31	
	1 7/16														
40	1 1/2	FC4251-12 FC4251-58 FC425-40	208	4 1/16	4	1 21/32	5 1/4	1/2	5/32	9/16	1 13/16	6 25/32	21/32	4.49	MB251-12-PA MB251-58-PA MB25-40-PA
	1 5/8			103.2	101.60	42.06	130.2	12	4.0	14.3	46.0	172.2	16.7	4.35	
45	1 5/8	FC4251-58L FC4251-1116 FC4251-34	209	4 5/16	4 1/8	1 49/64	5 3/8	9/16	1/8	9/16	1 29/32	7 3/32	23/32	4.85	MB251-58L-PA MB251-1116-PA MB251-34-PA
	1 11/16			109.5	104.78	44.86	136.5	14	3.2	14.3	48.4	180.2	18.3	4.78	
	1 3/4														
50	1 7/8	FC4251-78 FC4251-1516 FC4252	210	4 1/2	4 3/8	1 13/16	5 5/8	9/16	7/64	9/16	1 29/32	7 7/16	23/32	5.31	MB251-78-PA MB251-1516-PA MB252-PA
	1 15/16			114.3	111.12	46.02	142.9	14	2.8	14.3	48.4	188.9	18.3	5.22	
	2														
55	2	FC4252L FC4252-316 FC4252-14	211	5 3/16	5 1/8	1 13/16	6 3/8	5/8	11/64	5/8	2	8 1/2	11/16	7.53	MB252L-PA MB252-316-PA MB252-14-PA
	2 3/16			131.8	130.18	46.02	161.9	16	4.4	15.9	50.8	215.9	17.5	7.23	
	2 1/4														
60	2 1/4	FC4252-14L FC4252-38 FC4252-716	212	5 7/16	5 5/8	1 57/64	6 7/8	5/8	13/64	11/16	2 3/32	9 9/32	21/32	9.25	MB252-14L-PA MB252-38-PA MB252-716-PA
	2 3/8			138.1	142.88	48.03	174.6	16	5.2	17.5	53.2	235.7	16.7	9.01	
	2 7/16														
75	2 15/16	FC4252-1516	215	6 7/16	6	2 17/64	7 3/4	3/4	1/8	3/4	2 13/32	10 1/4	23/32	13.19	MB252-1516-PA
				163.5	152.40	57.56	196.8	20	3.2	19.0	61.1	260.4	18.3	6.0	

Lubrication fitting tap size; 203 thru 205 basic size, 1/4"-28UNF, 206 thru 215 basic size, 1/8" PT

Selection Guide – pages 4-6 & 37-39

Load Ratings – pages 40-41

Additional Information – page 42

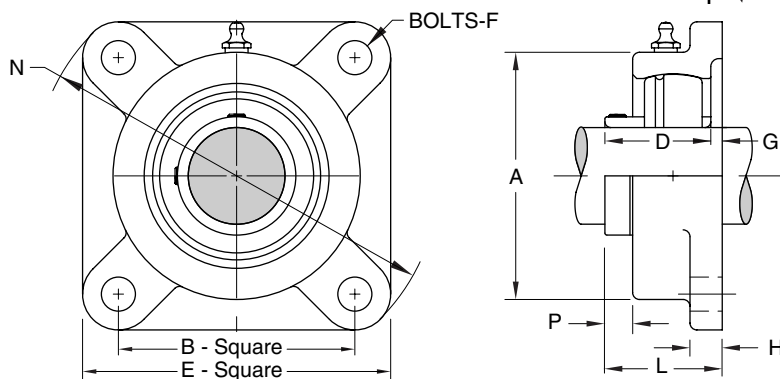

## 4-BOLT MEDIUM DUTY FLANGE UNITS

These flange units incorporate the advantages of foot mounted pillow blocks, but are intended for surface mounting, vertical or horizontal, at right angles to the shaft. Bolt holes are spaced for interchangeability with mountings of similar designs.

Shaft Dia. Inches	Flanged Unit Number	Basic Size	A	B	D	E	F Bolts	G	H	L	N	P	Unit Wt. (lbs/kg)	Bearing Number	
1	FC4351	206	3 3/16 81.0	3 1/4 82.55	1 11/32 34.14	4 1/4 108.0	7/16 10	9/64 3.6	1/2 12.7	1 1/2 38.1	5 19/32 142.1	9/16 14.3	2.58 1.2	MB351-PA	
1 3/16	FC4351-316	207	3 11/16 93.7	3 5/8 92.08	1 9/16 39.67	4 5/8 117.5	1/2 12	9/64 3.6	1/2 12.7	1 23/32 43.7	6 1/8 155.6	21/32 16.7	3.32 1.5	MB351-316-PA	
1 7/16	FC4351-716	208	4 1/16 103.2	4 101.60	1 21/32 42.06	5 1/4 130.2	1/2 12	5/32 4.0	9/16 14.3	1 13/16 46.0	6 25/32 172.2	21/32 16.7	4.55 2.1	MB351-716-PA	
1 1/2	FC4351-12	209	4 5/16 109.5	4 1/8 104.78	1 49/64 44.86	5 3/8 136.5	1/2 12	1/8 3.2	9/16 14.3	1 29/32 48.2	7 3/32 180.2	23/32 18.3	5.03 2.3	MB351-12-PA	
1 11/16	FC4351-1116	210	4 1/2 114.3	4 3/8 111.12	1 13/16 46.02	5 5/8 142.9	9/16 14	7/64 2.8	9/16 14.3	1 29/32 48.2	7 7/16 188.9	23/32 18.3	5.59 2.5	MB351-1116-PA MB351-34-PA	
1 3/4	FC4351-34		1 15/16 131.8	5 1/8 130.18	1 13/16 46.02	6 3/8 161.9	5/8 16	11/64 4.4	5/8 15.9	2 50.8	8 1/2 215.9	11/16 17.5	7.69 3.5	MB351-1516-PA MB352-PA	
1 15/16	FC4351-1516	212	2 131.8	5 1/8 130.18	1 13/16 46.02	6 3/8 161.9	5/8 16	11/64 4.4	5/8 15.9	2 50.8	8 1/2 215.9	11/16 17.5	7.69 3.5	MB351-1516-PA MB352-PA	
2	FC4352		2 3/16	FC4352-316	5 7/16 138.1	5 5/8 142.88	1 57/64 48.03	6 7/8 174.6	5/8 16	13/64 5.2	11/16 17.5	2 3/32 53.2	9 9/32 235.7	21/32 16.7	9.34 4.2
2 7/16	FC4352-716	214	2 1/2 155.6	5 7/8 149.2	2 15/64 56.74	7 3/8 187.3	5/8 16	1/8 3.2	11/16 17.5	2 3/8 60.3	9 13/16 249.2	23/32 18.3	12.27 5.6	MB352-716-PA MB352-12-PA	
2 1/2	FC4352-12		2 11/16	FC4352-1116	6 7/16 163.5	6 152.40	2 17/64 57.56	7 3/4 196.8	3/4 20	1/8 3.2	3/4 19.0	2 13/32 61.1	10 1/4 260.4	23/32 18.3	13.75 6.2
2 15/16	FC4352-1516	216	3 171.4	6 3/4 152.40	2 23/64 59.92	7 3/4 196.8	3/4 20	11/64 4.4	13/16 20.6	2 17/32 64.3	10 1/4 260.4	11/16 17.5	15.25 6.9	MB352-1516-PA MB353-PA	
3	FC4353		3 3/16	FC4353-316	7 3/4 196.8	6 3/4 171.4	2 33/64 63.91	8 7/16 214.3	3/4 20	7/32 5.6	15/16 23.8	2 47/64 44.0	11 1/4 285.8	21/32 16.7	21.11 20.22 9.2

Lubrication fitting tap size; 1/8" PT

Selection Guide – pages 4-6 & 37-39

Load Ratings – pages 40-41

Additional Information – page 42

4-Bolt flange units, like the foot mounted counterparts, are also provided with a grease fitting for relubrication purposes. The bolt hole size as well as spacing is interchangeable with other competitive units. Flange units are used in place of pillow blocks for side mounting without providing brackets or any other type of structure. Units are available in the same series and bore sizes as pillow blocks.

All MB flange units have been designed to maintain a minimum overall thickness with the smallest possible standoff dimension from the mounting face or back of flange to the outboard face of the inner race. This minimizes the necessity of extending shaft lengths and provides interchangeability with other competitive makes.

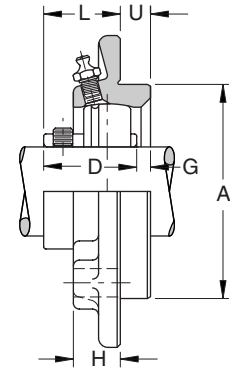
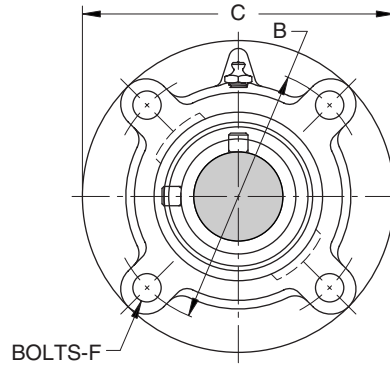

## 4-BOLT STANDARD DUTY PILOTED FLANGED UNITS

Shaft Dia. mm	Inches	Piloted Flange Unit Number	Basic Size	A	B	C	C	F	G	H	L	U	Unit Wt. (lbs/kg).	Bearing Number
				†				Bolts						
35	1 1/4	PFC4251-14	207	3.375	4 1/8	5	1 9/16	7/16	17/64	7/8	1 33/64	3/8	3.13	MB251-14-PA
	1 3/8	PFC4251-38		85.72	104.78	127.0	39.67	10	6.8	22.2	38.5	9.5	3.03	MB251-38-PA
	1 7/16	PFC4251-716 PFC425-35												2.97 1.4
40	1 1/2	PFC4251-12	208	3.625	4 3/8	5 1/4	1 21/32	7/16	1/4	7/8	1 17/32	7/16	3.63	MB251-12-PA
	1 5/8	PFC4251-58 PFC425-40		92.08	111.12	133.4	42.06	10	6.4	22.2	38.9	11.1	3.49 1.6	MB251-58-PA MB25-40-PA
45	1 5/8	PFC4251-58L	209	3.625	4 3/8	5 1/4	1 49/64	7/16	3/16	7/8	1 37/64	7/16	3.76	MB251-58L-PA
	1 11/16	PFC4251-1116		92.08	111.12	133.4	44.86	10	4.8	22.2	40.1	11.1	3.66 3.59	MB251-1116-PA MB251-34-PA
50	1 7/8	PFC4251-78	210	4.250	5 1/8	6 1/8	1 13/16	1/2	13/64	7/8	1 19/32	15/32	4.97	MB251-78-PA
	1 15/16	PFC4251-1516		107.95	130.18	155.6	46.02	12	5.2	22.2	40.5	11.9	4.88 4.79	MB251-1516-PA MB252-PA
55	2	PFC4252L	211	4.500	5 3/8	6 3/8	1 13/16	1/2	19/64	7/8	1 35/64	5/8	5.87	MB252L-PA
	2 3/16	PFC4252-316		114.30	136.52	161.9	46.02	12	7.5	22.2	39.3	15.9	5.57 5.47	MB252-316-PA MB252-14-PA
60	2 1/4	PFC4252-14L	212	5.000	6	7 1/8	1 57/64	9/16	37/64	1	1 11/16	7/8	8.40	MB252-14L-PA
	2 3/8	PFC4252-38		127.00	152.40	181.0	48.03	14	14.7	25.4	42.9	22.2	8.16 8.04	MB252-38-PA MB252-716-PA
75	2 15/16	PFC4252-1516	215	6.375	7 1/2	8 3/4	2 17/64	5/8	25/64	1	1 23/32	1	13.44	MB252-1516-PA
				161.92	190.50	222.2	57.56	16	9.9	25.4	43.7	25.4	6.1	

Lubrication fitting tap size; 1/8" PT

† Tolerance: +.000"--.002" (+0.00mm-0.05mm). Bore tolerance for mounting: +.002"--.000" (+0.05mm-0.00mm)

Selection Guide – pages 4-6 & 37-39

Load Ratings – pages 40-41

Additional Information – page 42

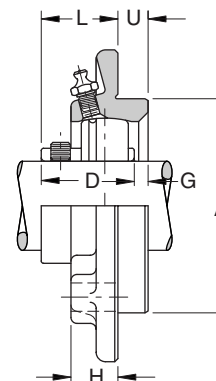
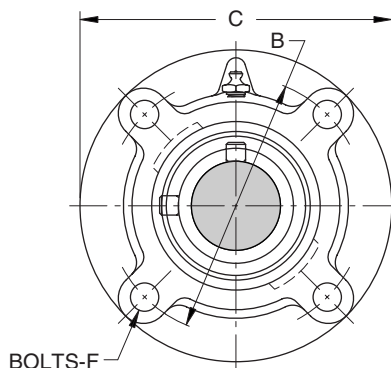

## 4-BOLT MEDIUM DUTY PILOTED FLANGED UNITS

Shaft Dia. Inches	Piloted Flange Unit Number	Basic Size	A †	B	C	D	F Bolts	G	H	L	U	Unit Wt. (lbs/kg)	Bearing Number
1 3/16	PFC4351-316	207	3.375 85.72	4 1/8 104.78	5 127.0	1 9/16 39.67	7/16 10	17/64 6.8	7/8 22.2	1 33/64 38.5	3/8 9.5	3.14 1.4	MB351-316-PA
1 7/16	PFC4351-716	208	3.625 92.08	4 3/8 111.12	5 1/4 133.4	1 21/32 42.06	7/16 10	1/4 6.4	7/8 22.2	1 17/32 38.9	7/16 11.1	3.69 1.7	MB351-716-PA
1 1/2	PFC4351-12	209	3.625 92.08	4 3/8 111.12	5 1/4 133.4	1 49/64 44.86	7/16 10	3/16 4.8	7/8 22.2	1 37/64 40.1	7/16 11.1	3.85 1.7	MB351-12-PA
1 11/16 1 3/4	PFC4351-1116 PFC4351-34	210	4.250 107.95	5 1/8 130.18	6 1/8 155.6	1 13/16 46.02	1/2 12	13/64 5.2	7/8 22.2	1 19/32 40.5	15/32 11.9	5.72 2.3	MB351-1116-PA MB351-34-PA
1 15/16 2	PFC4351-1516 PFC4352	211	4.500 114.30	5 3/8 136.52	6 3/8 161.9	1 13/16 46.02	1/2 12	19/64 7.5	7/8 22.2	1 35/64 39.3	5/8 15.9	5.96 2.7	MB351-1516-PA MB352-PA
2 3/16	PFC4352-316	212	5.000 127.00	5 152.40	7 1/8 181.0	1 57/64 48.03	9/16 14	37/64 14.7	1 25.4	1 11/64 42.9	1 25.4	8.52 3.9	MB352-316-PA
2 7/16 2 1/2	PFC4352-716 PFC4352-12	214	5.500 139.70	6 1/2 165.10	7 5/8 193.7	2 15/64 56.74	9/16 14	27/64 10.7	1 25.4	1 23/32 43.7	1 25.4	10.27 4.6	MB352-716-PA MB352-12-PA
2 11/16	PFC4352-1116	215	6.375 161.92	7 1/2 190.50	8 3/4 222.2	2 17/64 57.56	5/8 16	25/64 9.9	1 25.4	1 23/32 43.7	1 25.4	14.07 6.4	MB352-1116-PA
2 15/16 3	PFC4352-1516 PFC4353	216	6.375 161.92	7 1/2 190.50	8 3/4 222.2	2 23/64 59.92	5/8 16	21/64 8.3	1 1/8 28.6	1 11/16 42.9	1 25.4	13.92 6.3	MB352-1516-PA MB353-PA
3 3/16 3 7/16 3 1/2	PFC4353-316 PFC4353-716 PFC4353-12	218	7.375 187.32	8 5/8 219.08	10 1/4 260.4	2 33/64 63.91	3/4 20	25/64 10.0	1 1/8 28.6	1 51/64 45.6	1 1/8 28.6	21.90 21.01 9.5	MB353-316-PA MB353-716-PA MB353-12-PA

Lubrication fitting tap size; 1/8" PT

†Tolerance: +.000"-.002" (+0.00mm-0.05mm). Bore tolerance for mounting: +.002"-.000" (+0.05mm-0.00mm)

Selection Guide – pages 4-6 & 37-39

Load Ratings – pages 40-41

Additional Information – page 42

Piloted flange units provide an accurately machined piloted diameter adjacent to the mounting face to position the unit in a close-fitting bore in the mounting surface. This procedure accurately locates the bearing and shaft without further adjustment or alignment. Typical include machine builders and manufactures of equipment where the supporting side members are line bored to receive the piloted extension at the rear of the flange unit.

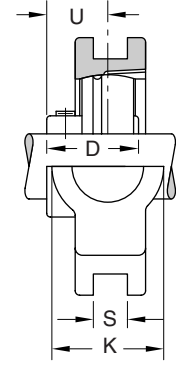
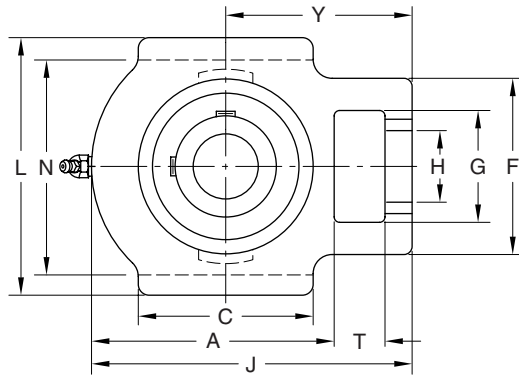

## STANDARD DUTY WIDE SLOT TAKE-UP UNITS

These take-up blocks provide support where shaft adjustment and belt-tightening devices or conveyor take-up pulleys are required.

Shaft Dia. mm	Inches	Takeup Unit Number	Basic Size	A	C	D	F	G	H	J	K	L	N †	S ††	T	U	Y	Unit Wt. (lbs/kg)	Bearing Number
20	3/4	TC25-34	204	2 7/8	2	1 1/8	2	1 1/4	3/4	3 7/8	1 3/8	3 1/2	3.000	.531	5/8	3/4	2 7/16	1.86	MB25-34-PA
		TC25-20		73.02	50.8	28.58	50.8	31.8	19.0	98.4	34.9	88.9	76.20	13.49	15.9	19.0	61.9	0.8	MB25-20-PA
25	7/8 15/16 1	TC25-78	205	2 7/8	2	1 11/64	2	1 1/4	3/4	3 7/8	1 3/8	3 1/2	3.000	.531	5/8	5 1/64	2 7/16	1.85	MB25-78-PA
		TC25-1516		73.02	50.8	29.77	50.8	31.8	19.0	98.4	34.9	88.9	76.20	13.49	15.9	20.2	61.9	1.82	MB25-1516-PA
		TC251		1.79															0.8
30	1 1/8 1 3/8 1 1/4	TC251-18	206	3 3/8	2 1/4	1 11/32	2 3/16	1 7/16	7/8	4 1/2	1 9/16	4 1/8	3.500	.531	1 1/16	6 1/64	2 3/4	2.75	MB251-18-PA
		TC251-316		85.7	57.2	34.14	55.6	36.5	22.2	114.3	39.7	104.8	88.90	13.49	17.5	24.2	69.8	2.72	MB251-316-PA
35	1 1/4 1 3/8 1 7/16	TC251-14	207	4	2 1/2	1 9/16	2 3/8	1 7/16	7/8	5	1 9/16	4 1/8	3.500	.531	1 1/16	1 7/64	3 1/16	3.19	MB251-14-PA
		TC251-38		101.6	63.5	39.67	60.3	36.5	22.2	127.0	39.7	104.8	88.90	13.49	17.5	28.2	77.8	3.09	MB251-38-PA
40	1 1/2 1 5/8	TC251-12	208	4 3/16	3 1/4	1 21/32	3 1/4	1 15/16	1 1/8	5 5/8	2 1/16	4 3/4	3.969	.688	7/8	1 11/64	3 1/2	5.24	MB251-12-PA
		TC251-58		106.4	82.6	42.06	82.6	49.2	28.6	133.4	52.4	120.6	100.81	17.48	22.2	29.8	88.9	5.10	MB251-58-PA
45	1 5/8 1 11/16 1 3/4	TC251-58L	209	4 3/16	3 1/4	1 49/64	3 1/4	1 15/16	1 1/8	5 5/8	2 1/16	4 3/4	3.969	.688	7/8	1 15/64	3 7/16	4.84	MB251-58L-PA
		TC251-1116		106.4	82.6	44.86	82.6	49.2	28.6	133.4	52.4	120.6	100.81	17.48	22.2	31.3	87.3	4.77	MB251-1116-PA
50	1 7/8 1 15/16 2	TC251-78	210	4 7/16	3 1/4	1 13/16	3 1/4	1 15/16	1 1/8	5 7/8	2 1/16	4 3/4	3.969	.688	7/8	1 17/64	3 9/16	4.96	MB251-78-PA
		TC251-1516		112.7	82.6	46.02	82.6	49.2	28.6	149.2	52.4	120.6	100.81	17.48	22.2	32.2	90.5	4.87	MB251-1516-PA
55	2 2 3/16 2 1/4	TC252L	211	4 7/8	3 3/4	1 13/16	4	2 1/2	1 3/8	6 13/16	2 1/2	5 7/8	5.094	1.062	1 3/16	1 9/32	4 3/16	8.78	MB252L-PA
		TC252-316		123.8	95.2	46.02	101.6	63.5	34.9	173.0	63.5	149.2	129.39	26.97	30.2	32.5	106.4	8.58	MB252-316-PA
60	2 1/4 2 3/8 2 7/16	TC252-14L	212	5 5/8	4	1 57/64	4	2 1/2	1 3/8	7 9/16	2 1/2	5 7/8	5.094	1.062	1 3/16	1 5/16	4 11/16	9.67	MB252-14L-PA
		TC252-38		142.9	101.6	48.03	101.6	63.5	34.9	192.1	63.5	149.2	129.39	26.97	30.2	33.3	119.1	9.43	MB252-38-PA
75	2 15/16	TC252-716	215	6 27/32	4 3/4	2 17/64	4 3/16	2 3/4	1 5/8	8 15/16	2 3/4	6 11/16	5.906	1.062	1 5/16	1 15/32	5 1/2	14.24	MB252-716-PA
		TC252-1516		173.8	120.6	57.56	106.4	69.8	41.3	227.0	69.8	169.9	150.01	26.97	33.3	37.3	139.7	6.4	MB252-1516-PA

Lubrication fitting tap size; 1/8" PT  
 † Tolerance: +.000" -.015" (+0.00mm -0.38mm)  
 †† Tolerance: +.005" -.015" (+0.013mm -0.38mm)

Selection Guide – pages 4-6 & 37-39  
 Load Ratings – pages 40-41  
 Additional Information – page 42

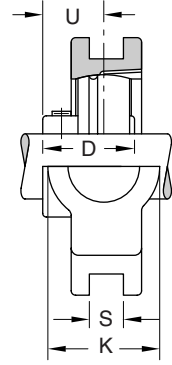
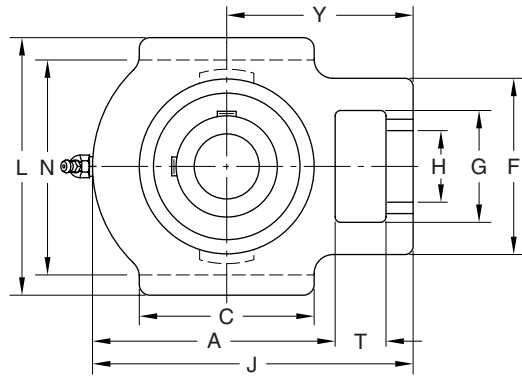

## MEDIUM DUTY WIDE SLOT TAKE-UP UNITS

These take-up blocks provide support where shaft adjustment and belt-tightening devices or conveyor take-up pulleys are required.

Shaft Dia. Inches	Takeup Unit Number	Basic Size	A	C	D	F	G	H	J	K	L	N †	S ††	T	U	Y	Unit Wt. (lbs/kg)	Bearing Number
1	TC351	206	3 3/8 85.7	2 1/4 57.2	1 11/32 34.14	2 3/16 55.6	1 7/16 36.5	7/8 22.2	4 1/2 114.3	1 9/16 39.7	4 1/8 104.8	3.500 88.90	.531 13.49	1 11/16 17.5	6 1/64 24.2	2 3/4 69.8	2.88 1.3	MB351-PA
1 3/16	TC351-316	207	4 101.6	2 1/2 63.5	1 9/16 39.67	2 3/8 60.3	1 7/16 36.5	7/8 22.2	5 127.0	1 9/16 39.7	4 1/8 104.8	3.500 88.90	.531 13.49	1 11/16 17.5	1 7/64 28.2	3 1/16 77.8	3.20 1.5	MB351-316-PA
1 7/16	TC351-716	208	4 3/16 106.4	3 1/4 82.6	1 21/32 42.06	3 1/4 82.6	1 15/16 49.2	1 1/8 28.6	5 5/8 133.4	2 1/16 52.4	4 3/4 120.6	3.969 100.81	.688 17.48	7/8 22.2	1 11/64 29.8	3 1/2 88.9	5.29 2.4	MB351-716-PA
1 1/2	TC351-12	209	4 3/16 106.4	3 1/4 82.6	1 49/64 44.86	3 1/4 82.6	1 15/16 49.2	1 1/8 28.6	5 5/8 133.4	2 1/16 52.4	4 3/4 120.6	3.969 100.81	.688 17.48	7/8 22.2	1 15/64 31.3	3 7/16 87.3	4.96 2.2	MB351-12-PA
1 11/16	TC351-1116	210	4 7/16 112.7	3 1/4 82.6	1 13/16 46.02	3 1/4 82.6	1 15/16 49.2	1 1/8 28.6	5 7/8 149.2	2 1/16 52.4	4 3/4 120.6	3.969 100.81	.688 17.48	7/8 22.2	1 17/64 32.2	3 9/16 90.5	5.21 2.4	MB351-1116-PA
1 3/4	TC351-34		4 7/8 123.8	3 3/4 95.2	1 13/16 46.02	4 101.6	2 1/2 63.5	1 3/8 34.9	6 13/16 173.0	2 1/2 63.5	5 7/8 149.2	5.094 129.39	1.062 26.97	1 3/16 30.2	1 9/32 32.5	4 3/16 106.4	8.87 4.0	MB351-1516-PA
1 15/16	TC351-1516	211	4 7/8 123.8	3 3/4 95.2	1 13/16 46.02	4 101.6	2 1/2 63.5	1 3/8 34.9	6 13/16 173.0	2 1/2 63.5	5 7/8 149.2	5.094 129.39	1.062 26.97	1 3/16 30.2	1 9/32 32.5	4 3/16 106.4	8.87 4.0	MB351-1516-PA
2 3/16	TC352-316	212	5 5/8 142.9	4 101.6	1 57/64 48.03	4 101.6	2 1/2 63.5	1 3/8 34.9	7 9/16 192.1	2 1/2 63.5	5 7/8 149.2	5.094 129.39	1.062 26.97	1 3/16 30.2	1 9/16 33.3	4 11/16 119.1	8.79 4.0	MB352-316-PA
2 7/16	TC352-716		6 19/32 167.5	4 3/4 120.6	2 15/64 56.74	4 3/8 111.1	2 3/4 69.8	1 5/8 41.3	8 11/16 220.7	2 3/4 69.8	6 11/16 169.9	5.906 150.01	1.062 26.97	1 5/16 33.3	1 7/16 36.5	5 3/8 136.5	15.09 2.2	MB352-716-PA
2 1/2	TC352-12	214	6 19/32 167.5	4 3/4 120.6	2 15/64 56.74	4 3/8 111.1	2 3/4 69.8	1 5/8 41.3	8 11/16 220.7	2 3/4 69.8	6 11/16 169.9	5.906 150.01	1.062 26.97	1 5/16 33.3	1 7/16 36.5	5 3/8 136.5	15.09 2.2	MB352-12-PA
2 11/16	TC352-1116		6 27/32 173.8	4 3/4 120.6	2 17/64 57.56	4 3/8 111.1	2 3/4 69.8	1 5/8 41.3	8 15/16 227.0	2 3/4 69.8	6 11/16 169.9	5.906 150.01	1.062 26.97	1 5/16 33.3	1 15/32 37.3	5 1/2 139.7	14.87 6.7	MB352-1116-PA

Lubrication fitting tap size: 1/8" PT

†Tolerance: +.000" -.015" (+0.00mm -0.38mm)

††Tolerance: +.005" -.015" (+0.013mm -0.38mm)

Selection Guide – pages 4-6 & 37-39

Load Ratings – pages 40-41

Additional Information – page 42

Take-up units provide support where shaft adjustment and belt tightening devices or conveyor take-up pulleys are required. The take-up units slide in added-on frames or frames that are an integral part of the equipment and a screw or nut adjusts the bearing position.

Adjustment is usually manual, but modifications include adjustments by air cylinders or springs for constant tension. Each shaft usually requires two frames and a typical installation would be a belt conveyor. Take-up units serve as a tensioning device compensating for belt stretch and, by adjusting only one side, the belt can be positioned to run on center.



# STANDARD DUTY BALL BEARING TAKE-UPS

The "T" Frame is a uniquely designed module used as a conveyor belt take-up. Used in pairs, it acts as a belt tensioner as well as a belt trainer. They use standard Rexnord Bearing Products pillow blocks or tapped base pillow blocks. Threaded internal adjuster is totally enclosed and is protected against product build-up, rust, corrosion or thread damage. Adjuster tube acts as a built-in lubricant reservoir. Available in powder coated mild steel, or 304 stainless steel. Quick-Release method are also available for fast belt change over or clean up.

## "T" FRAME TAKE-UP BLOCKS

TP, TPT, TSP and TSPT Protected Screw

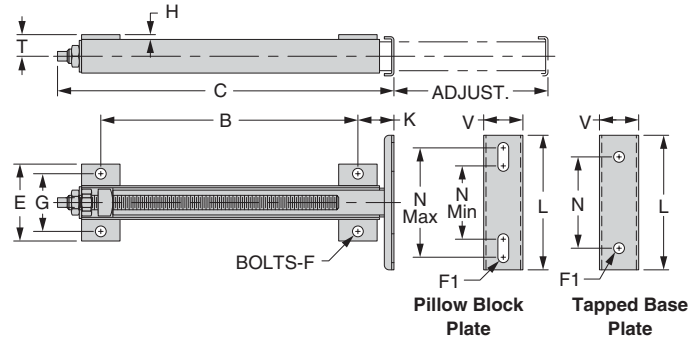

Basic Size No.	Adjustment	B	C	E	F Bolts	G	H	K	T	Adjusting Screw		Unit Weight (Lbs.)	
										Sq. Drive	Thread	Steel	Stainless
100	3	3 9/16	6 7/8	3 11/16	3/8	2 5/8	1/4	1 1/2	7/8	3/8	5/8-11	3.0	2.6
	6	7 1/16	10 3/8									4.0	3.5
	9	11 1/16	14 3/8									5.1	4.4
250	3	4 3/8	8 1/2	4	1/2	3	1/4	1 7/8	1 1/8	1/2	3/4-10	5.8	4.8
	6	7 3/8	11 1/2									7.1	5.8
	9	10 3/8	14 1/2									8.4	7.5
300	6	6 1/8	11 1/8	5 1/4	5/8	4	1/4	2 1/4	1 1/2	1/2	7/8-9	11.0	11.4
	9	10 1/8	15 1/8									13.1	13.4
	12	14 1/8	19 1/8									16.5	16.5
400	12	20	27 3/4	7 1/2	3/4	5 1/2	1/4	3 1/2	2 1/8	pinned nut	1 1/4-7	42.9	...
	18	26	33 3/4									52.1	...
	24	32	39 3/4									61.3	...

Prefix for T-Frame Part No. – Pillow Block mtg.

TP Mild Steel, Powder Coated  
TSP Stainless Steel

Prefix for T-Frame Part No. – Tapped Base Pillow Blk mtg.

TPT Mild Steel, Powder Coated  
TSPT Stainless Steel

## STANDARD DUTY BALL BEARING TAKE-UPS

TQP Quick Release Frame

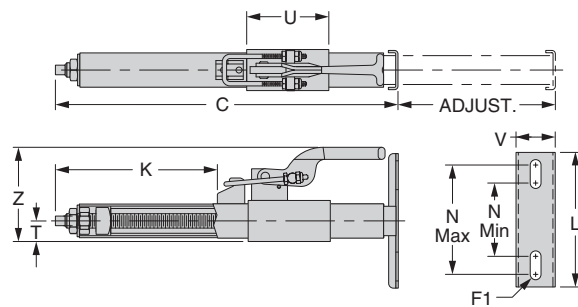

Shaft Dia.	Adjustment	T Frame Number	C	F1 Bolts	K	L	N		T	U	V	Z	Adjusting Screw		Unit Weight (Lbs.)
							Min.	Max.					Sq. Drive	Thread	
1/2 Thru 1	6	TQP100-6 TQP100-9	10 3/8 14 3/8	3/8	3 23/32 5 23/32	5 1/4	2 15/16	4 5/16	3/4	3 5	1 1/2	37/16	3/8	5/8 - 11	4.0
	9														5.0
1 1/8 Thru 1 3/4	6	TQP250-6 TQP250-9 TQP250-12	11 1/2 14 1/2 17 1/2	1/2	19/16 3 1/16 4 9/16	7	3 13/16	5 11/16	1	4 6 8	2 1/32	47/8	1/2	3/4 - 10	7.0
	9														8.2
	12														9.5

Selection Guide – pages 4-6 & 37-39  
Additional Information – page 42

# SELECTION CHART PILLOW BLOCK SIZES AND SERIES

## PILLOW BLOCK MOUNTING

Basic Size Number	T-Frame Basic Number	Shaft Diameter	Pillow Block Number		F1 Bolts	L	N		V
			Standard Backing	Low Backing			Min.	Max.	
100	100-3 100-6 100-9	1/2 5/8 11/16 3/4 7/8 15/16 1	C25-12 C25-58 C25-1116 C25-34 C25-78 C25-1516 C251	CL25-12 CL25-58 CL25-1116 CL25-34 CL25-78 CL25-1516 CL251	3/8	5 1/4	2 15/16	4 5/16	1 1/2
200	250-3 250-6 250-9 250-12	1 1/8 1 3/16 1 1/4 1 1/4 1 3/8 1 7/16 1 1/2 1 5/8 1 5/8 1 11/16 1 3/4	C251-18 C251-316 C251-14S C251-14 C251-38 C251-716 C251-12 C251-58 C251-58L C251-1116 C251-34	CL251-18 CL251-316 CL251-14S CL251-14 CL251-38 CL251-716 CL251-12 CL251-58 CL251-58L CL251-1116 CL251-34	1/2	6	3 13/16	5 11/16	2 1/32
300	300-6 300-9 300-12 300-18	1 7/8 1 15/16 2 2 2 3/16 2 1/4 2 1/4 2 3/8 2 7/16	C251-78 C251-1516 C252 C252L C252-316 C252-14 C252-14L C252-38 C252-716	CL251-78 CL251-1516 CL252 CL252L CL252-316 CL252-14 CL252-14L CL252-38 CL252-716	5/8	10	5 9/16	8 11/16	2 27/32
400	400-12 400-18 400-24	2 15/16	C252-1516	CL252-1516	3/4	14	8 1/2	11 3/4	3 1/2

### Prefix for T-Frame Part No. –

TP Mild Steel, Powder Coated

TSP Stainless Steel

TQP Stainless Steel, Quick Release

## TAPPED BASE PILLOW BLOCK MOUNTING

Basic Size Number	T-Frame Number		Shaft Diameter	Pillow Block Number	F1 Bolts	L	N	V
	Steel	Stainless						
100	TPT100-3 TPT100-6 TPT100-9	TSTP100-3 TSTP100-6 TSPT100-9	1/2 5/8 11/16 3/4 7/8 15/16 1	TBC25-12 TBC25-58 TBC25-1116 TBC25-34 TBC25-78 TBC25-1516 TBC251	3/8	3	2	1 1/2
200	TPT2501-3 TPT2501-6 TPT2501-9 TPT2501-12	TSPT2501-3 TSPT2501-6 TSPT2501-9 TSPT2501-12	1 1/8 1 3/16 1 1/4	TBC251-18 TBC251-316 TBC251-14S	7/16	4	3	1 1/2
250	TPT2502-3 TPT2502-6 TPT2502-9 TPT2502-12	TSPT2502-3 TSPT2502-6 TSPT2502-9 TSPT2502-12	1 1/4 1 3/8 1 7/16	TBC251-14 TBC251-38 TBC251-716	1/2	4 1/4	3 1/4	2
250	TPT2505-3 TPT2505-6 TPT2505-9 TPT2505-12	TSPT2505-3 TSPT2505-6 TSPT2505-9 TSPT2505-12	1 7/8 1 15/16 2	TBC251-78 TBC251-1516 TBC252	5/8	5 1/2	4	2

To order frame, specify prefix, size and adjustment.(I.e.TP100-6) Pillow blocks ordered and sold separately

Selection Guide – pages 4-6 & 37-39

Additional Information – page 42



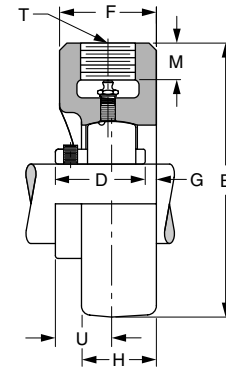
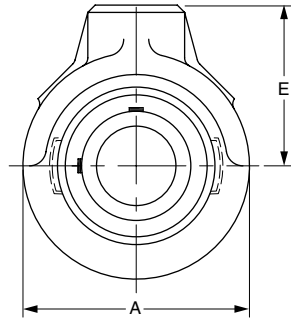

## STANDARD DUTY SCREW CONVEYOR HANGER BEARINGS

These units are for screw conveyor applications. The housings are tapped for a straight pipe thread. The units are designed to be supported by high strength pipe as well as secured with a lock nut supplied by the user.

Shaft Dia. mm	Inches	Hanger Unit Number	Basic Size	A	B	D	E	F	G	H	T		U	Unit Wt. (lbs/kg)	Bearing Number		
											Tap	Depth					
30	1	MCHB1	206	3 3/8	4 3/16	1 11/32	2 1/2	1 21/32	7/16	1 7/32	3/4-14	5/8	61/64	2.34	MB351-PA		
	1 1/8	MCHB1-18												2.25		MB251-18-PA	
	1 3/16	MCHB1-316S												2.22			MB251-316-PA
	1 1/4	MCHB1-14S												2.19			
	MCHB-30	1.0	MB251-30-PA														
35	1 3/16	MCHB1-316		207	3 7/8	4 11/16	1 9/16	2 3/4	1 21/32	3/8	1 9/32	3/4-14	5/8	1 7/64	3.35	MB351-316-PA	
	1 1/4	MCHB1-14													3.34		MB251-14-PA
	1 3/8	MCHB1-38													3.24		
	1 7/16	MCHB1-716S	3.18												MB251-716-PA		
	MCHB-35	1.5	MB251-35-PA														
40	1 7/16	MCHB1-716		208	4	4 7/8	1 21/32	2 7/8	1 21/32	11/32	1 11/32	3/4-14	5/8	1 11/64		3.44	MB351-716-PA
	1 1/2	MCHB1-12														3.39	
	1 5/8	MCHB1-58													3.25	KMB251-58-PA	
		MCHB-40	1.5												KMB251-40-PA		
50	1 11/16	MCHB1-1116	210	4 5/8	5 9/16	1 13/16	3 1/4	1 7/8	13/32	1 13/32	1-11 1/2	13/16	1 17/64	5.06			MB351-1116-PA
	1 3/4	MCHB1-34												4.98			
	1 7/8	MCHB1-78												4.81		MB251-78-PA	
	1 15/16	MCHB1-1516												4.72	MB251-1516-PA		
2	MCHB2	4.63	MB252-PA														
		2.1															
60	2 3/16	MCHB2-316		212	5 5/8	6 13/16	1 57/64	4	2 5/16	37/64	1 5/8	1 1/4-11 1/2	1 1/8	1 5/16		8.44	MB352-316-PA
	2 3/8	MCHB2-38													8.08	MB252-38-PA	
	2 7/16	MCHB2-716	7.96												MB252-716-PA		
			3.6														
75	2 11/16	MCHB2-1116	215	6 1/2	7 7/8	2 17/64	4 5/8	2 3/4	37/64	1 31/32	1 1/2-11 1/2	1 1/4	1 15/32	12.27			MB352-1116-PA
	2 3/4	MCHB2-34												12.14		MB252-34-PA	
	2 15/16	MCHB2-1516												11.64	MB252-1516-PA		
														5.3			
80	2 15/16	MCHB2-1516L	216	7	8 3/8	2 23/64	4 7/8	2 13/16	35/64	2 1/16	1 1/2-11 1/2	1 1/4	1 1/2	16.00			MB352-1516-PA
	3	MCHB3												15.82		MB353-PA	
														7.2			
75	3 3/16	MCHB3-316	218	8 5/16	10 5/32	2 33/64	6	3 1/2	25/32	2 1/8	2-11 1/2	1 3/4	1 9/16	25.66	MB353-316-PA		
	3 7/16	MCHB3-716												24.77		MB353-716-PA	
	3 1/2	MCHB3-12												24.58			MB353-12-PA
														11.1			

Lubrication fitting tap size; 1/8" PT

Selection Guide – pages 4-6 & 37-39

Load Ratings – pages 40-41

Additional Information – page 42

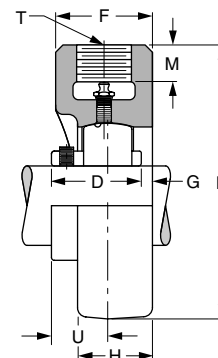
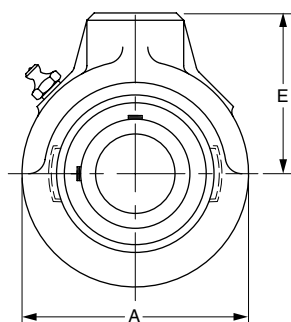

## STANDARD DUTY HANGER BEARINGS

These units are for screw conveyor applications. The housings are tapped for a straight pipe thread. The units are designed to be supported by high strength pipe as well as secured with a lock nut supplied by the user.

Shaft Dia. mm	Inches	Hanger Unit Number	Basic Size	A	B	D	E	F	G	H	T		U	Unit wt. (lbs/kg)	Bearing Number
											Tap	Depth			
30	1	MEHB1	206	3 3/8	4 3/6	1 11/32	2 1/2	1 21/32	7/16	1 7/32	3/4-14	5/8	61/64	2.34	MB351-PA MB251-18-PA MB251-316-PA MB251-14S-PA MB25-30-PA
	1 1/8	MEHB1-18												2.25	
	1 3/16	MEHB1-316S												2.22	
	1 1/4	MEHB1-14S MEHB-30												2.19 1.0	
35	1 3/16	MEHB1-316	207	3 7/8	4 11/16	1 9/16	2 3/4	1 21/32	3/8	1 9/32	3/4-14	5/8	1 7/64	3.35	MB351-316-PA MB251-14-PA MB251-38-PA MB251-716-PA MB25-35-PA
	1 1/4	MEHB1-14												3.34	
	1 3/8	MEHB1-38												3.24	
	1 7/16	MEHB1-716S MEHB-35												3.18 1.5	
40	1 7/16	MEHB1-716	208	4	4 7/8	1 21/32	2 7/8	1 21/32	11/32	1 11/32	3/4-14	5/8	1 11/64	3.44	MB351-716-PA MB251-12-PA KMB251-58-PA KMB25-40-PA
	1 1/2	MEHB1-12												3.39	
	1 5/8	MEHB1-58 MEHB-40												3.25 1.5	
50	1 11/16	MEHB1-1116	210	4 5/8	5 9/16	1 13/16	3 1/4	1 7/8	13/32	1 13/32	1-11 1/2	13/16	1 17/64	5.06	MB351-1116-PA MB251-34-PA MB251-78-PA MB251-1516-PA MB252-PA
	1 3/4	MEHB1-34												4.98	
	1 7/8	MEHB1-78												4.81	
	1 15/16	MEHB1-1516												4.72	
60	2	MEHB2	212	5 5/8	6 13/16	1 57/64	4	2 5/16	37/64	1 5/8	1 1/4-11 1/2	1 1/8	1 5/16	4.63	MB352-316-PA MB252-38-PA MB252-716-PA
	2 3/16	MEHB2-316												2.1	
	2 3/8	MEHB2-38												8.44	
	2 7/16	MEHB2-716												8.08 7.96 3.6	
75	2 11/16	MEHB2-1116	215	6 1/2	7 7/8	2 17/64	4 5/8	2 3/4	37/64	1 31/32	1 1/2-11 1/2	1 1/4	1 15/32	12.27	MB352-1116-PA MB252-34-PA MB252-1516-PA
	2 3/4	MEHB2-34												12.14	
	2 15/16	MEHB2-1516												11.64 5.3	
80	2 15/16	MEHB2-1516L	216	7	8 3/8	2 23/64	4 7/8	2 13/16	35/64	2 1/16	1 1/2-11 1/2	1 1/4	1 1/2	16.00	MB352-1516-PA MB353-PA
	3	MEHB3												15.82 7.2	
75	3 3/16	MEHB3-316	218	8 5/16	10 5/32	2 33/64	6	3 1/2	25/32	2 1/8	2-11 1/2	1 3/4	1 9/16	25.66	MB353-316-PA MB353-716-PA MB353-12-PA
	3 7/16	MEHB3-716												24.77	
	3 1/2	MEHB3-12												24.58 11.1	

Lubrication fitting tap size; 1/8" PT

Selection Guide – pages 4-6 & 37-39

Load Ratings – pages 40-41

Additional Information – page 42

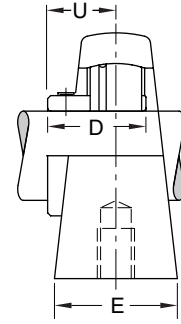
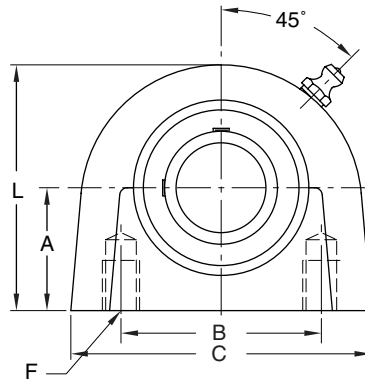
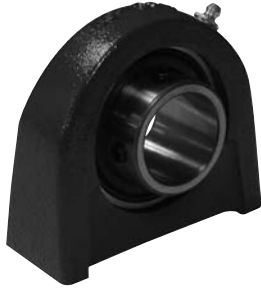

## STANDARD DUTY TAPPED BASE PILLOW BLOCK MOUNTINGS

Tapped base pillow block mountings can be obtained for applications having space limitations, such as close spacing of conveying rolls. The “feet” of the standard pillow block housing is eliminated. The base is drilled and tapped from the underside for mounting bolts.

Shaft Dia. mm	Inches	Pillow Block Number	Basic Size	A †	B	C	D	E	F		L	U	Unit wt. (lbs/kg)	Bearing Number			
									Tap	Depth							
17	1/2 5/8 11/16	TBC25-12	203	1 5/16	2	2 7/8	63/64	1 5/16	3/8-16	1/2	2 13/32	41/64	1.06	MB25-12-PA MB25-58-PA MB25-1116-PA			
		TBC25-58		33.32	50.80	73.0	24.99	33.32					1.00				
		TBC25-1116						12.7					61.1		16.3	0.4	
20	3/4	TBC25-34	204	1 5/16	2	2 7/8	1 1/8	1 7/16	3/8-16	1/2	2 17/32	3/4	1.20	MB25-34-PA MB25-20-PA			
		TBC25-20		33.32	50.80	73.0	28.58	36.52					12.7		64.3	19.0	0.5
25	7/8 15/16 1	TBC25-78	205	1 7/16	2	3	1 11/64	1 7/16	3/8-16	1/2	2 13/16	51/64	1.40	MB25-78-PA MB25-1516-PA MB251-PA MB25-25-PA			
		TBC25-1516		36.52	50.80	76.2	29.77	36.52					12.7		71.4	20.2	0.6
		TBC251															
30	1 1/8 1 3/16 1 1/4	TBC251-18	206	1 11/16	3	4	1 11/32	1 5/8	7/16-14	5/8	3 1/4	61/64	2.35	MB251-18-PA MB251-316-PA MB251-14S-PA MB25-30-PA			
		TBC251-316		42.88	76.20	101.6	34.14	41.28					15.9		82.6	24.2	1.0
35	1 1/4 1 3/8 1 7/16	TBC251-14	207	1 7/8	3 1/4	4 1/4	1 9/16	1 3/4	1/2-13	3/4	3 11/16	1 7/64	3.13	MB251-14-PA MB251-38-PA MB251-716-PA MB25-35-PA			
		TBC251-38		47.62	82.55	108.0	39.67	44.45					19.0		93.7	28.2	1.4
		TBC251-716															
40	1 1/2 1 5/8	TBC251-12	208	1 15/16	3 1/2	4 5/8	1 21/32	1 7/8	1/2-13	3/4	3 15/16	1 11/64	3.67	MB251-12-PA MB251-58-PA MB25-40-PA			
		TBC251-58		49.22	88.90	117.5	42.06	47.62					19.0		100.0	29.8	1.6
45	1 5/8 1 11/16 1 3/4	TBC251-58L	209	2 1/8	3 3/4	5	1 49/64	2	1/2-13	3/4	4 1/4	1 15/64	4.75	MB251-58L-PA MB251-1116-PA MB251-34-PA			
		TBC251-1116		53.98	95.25	127.0	44.86	50.80					19.0		108.0	31.3	2.1
		TBC251-34															
50	1 7/8 1 15/16 2	TBC251-78	210	2 1/4	4	5 1/2	1 13/16	2 1/8	5/8-11	7/8	4 1/2	1 17/64	5.66	MB251-78-PA MB251-1516-PA MB252-PA			
		TBC251-1516		57.15	101.60	139.7	46.02	53.98					22.2		114.3	32.2	2.5
		TBC252															

Lubrication fitting tap size; 203 thru 205 basic size, 1/4"-28UNF, 206 thru 210 basic size, 1/8" PT  
 † Tolerance, ±.005" (±0.13mm)

Selection Guide – pages 4-6 & 37-39  
 Load Ratings – pages 40-41  
 Additional Information – page 42

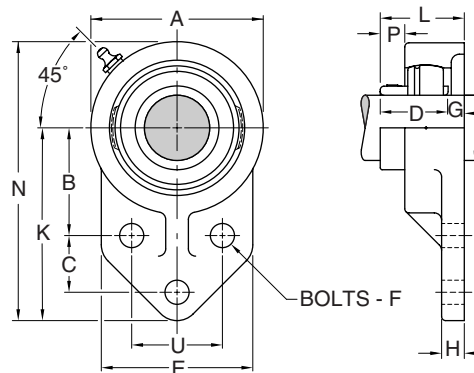

### 3-BOLT FLANGE STANDARD DUTY BRACKET UNITS

The 3-bolt flange bracket unit is intended for mounting conditions where space limitations will not permit using another type of premounted ball bearing pillow block design. For instance, the 3-bolt flange bracket is well suited for surface mounting in any type of equipment where there is insufficient mounting space available for another type of bearing design.

Shaft Dia. mm	Inches	Flanged Bracket Unit Number	Basic Size	A	B	C	D	E	F Bolts	G	H	K	L	N	P	U	Unit wt. (lbs/kg)	Bearing Number
20	3/4	MFB25-34 MFB25-20	204	2 1/2 63.5	1 11/16 42.9	7/8 22.2	1 1/8 28.58	2 3/8 60.3	3/8 10	1/4 6.4	5/16 7.9	3 76.2	1 3/8 34.9	4 1/4 108.0	25/64 9.9	1 1/2 38.1	1.44 0.6	MB25-34-PA MB25-20-PA
25	7/8 15/16 1	MFB25-78	205	2 3/4 69.8	1 13/16 46.0	1 1/8 28.6	1 11/64 29.77	2 1/2 63.5	3/8 10	23/64 9.1	3/8 9.5	3 3/8 85.7	1 17/32 38.9	4 3/4 120.6	27/64 10.7	1 5/8 41.3	1.80	MB25-78-PA
		MFB25-1516															1.77	MB25-1516-PA
		MFB25-25															1.74 0.8	MB251-PA MB25-25-PA
30	1 1/8 1 3/16 1 1/4	MFB251-18	206	3 1/4 82.6	2 1/16 52.3	1 1/4 31.8	1 11/32 34.14	2 3/4 69.8	3/8 10	17/64 6.8	3/8 9.5	3 3/4 95.2	1 43/64 42.5	5 3/8 136.5	35/64 13.9	1 7/8 47.6	2.07	MB251-18-PA
		MFB251-316															2.04	MB251-316-PA
		MFB251-14S MFB25-30															2.01 0.9	MB251-PA MB25-30-PA
35	1 1/4 1 3/8 1 7/16	MFB251-14	207	3 3/4 95.2	2 3/8 60.3	1 1/4 31.8	1 9/16 39.67	3 11/32 85.3	1/2 12	25/64 9.9	1/2 12.7	4 1/4 108.0	1 61/64 49.6	6 1/8 155.6	41/64 16.3	2 50.8	3.45	MB251-14-PA
		MFB251-38															3.35	MB251-38-PA
		MFB251-716 MFB25-35															3.29 1.5	MB251-716-PA MB25-35-PA

Lubrication fitting tap size; 204 and 205 basic size, 1/4"-28UNF, 206 and 207 basic size, 1/8" PT

Selection Guide – pages 4-6 & 37-39

Load Ratings – pages 40-41

Additional Information – page 42

3-Bolt flange units are available in standard shaft sizes with the bolt hole size and spacing interchangeable with other competitive units. This does not mean the units are interchangeable in all respects with competition, but can be considered interchangeable in most instances. The units should be thoroughly compared if complete dimensional interchangeability is essential.

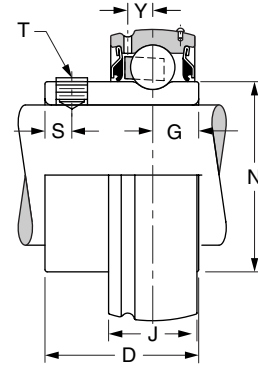
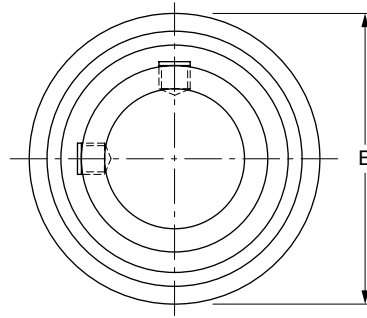

## MB25 STANDARD DUTY SERIES BEARINGS ONLY with Concentric Setscrew Locking Device

Shaft Dia. mm	Inches	Bearing Number	Basic Size	Bore Tolerance	B †	D	G	J	N	S	T Tap Size	Y	Unit wt. (lbs/kg)	
17	1/2 5/8 11/16	MB25-12-PA	203	+0.0005-.0000	1.5748	63/64	.344	.5118	.941	.19	#10-32	.158	0.25	
		MB25-58-PA												0.21
		MB25-1116-PA												
20	3/4	MB25-34-PA	204	+0.0005-.0000	1.8504	1 1/8	.376	.5906	1.121	.23	1/4-28	.176	0.32	
		MB25-20-PA												28.47
25	7/8 15/16 1	MB25-78-PA	205	+0.0005-.0000	2.0472	1 11/64	.376	.5906	1.313	.25	1/4-28	.176	0.43	
		MB25-1516-PA												0.40
		MB251-PA												
30	1 1/8 1 3/16 1 1/4	MB251-18-PA	206	+0.0005-.0000	2.4409	1 11/32	.392	.7087	1.587	.31	5/16-24	.202	0.63	
		MB251-316-PA												0.60
		MB251-14S-PA												
35	1 1/4 1 3/8 1 7/16	MB251-14-PA	207	+0.0005-.0000	2.8346	1 9/16	.454	.7480	1.847	.34	5/16-24	.227	1.02	
		MB251-38-PA												0.92
		MB251-716-PA												
40	1 1/2 1 5/8	MB251-12-PA	208	+0.0005-.0000	3.1496	1 21/32	.485	.8661	2.083	.34	5/16-24	.263	1.27	
		MB251-58-PA												1.20
		MB25-40-PA												
45	1 5/8 1 11/16 1 3/4	MB251-58L-PA	209	+0.0005-.0000	3.3465	1 49/64	.532	.8661	2.281	.36	5/16-24	.256	1.50	
		MB251-1116-PA												1.43
		MB251-34-PA												
50	1 7/8 1 15/16 2	MB251-78-PA	210	+0.0005-.0000	3.5433	1 13/16	.532	.8661	2.475	.38	3/8-24	.256	1.57	
		MB251-1516-PA												1.48
		MB252-PA												
55	2 2 3/16 2 1/4	MB252L-PA	211	+0.0005-.0000	3.9370	1 13/16	.537	.9843	2.749	.38	3/8-24	.298	2.27	
		MB252-316-PA												1.97
		MB252-14-PA												
60	2 1/4 2 3/8 2 7/16	MB252-14L-PA	212	+0.0006-.0000	4.3307	1 57/64	.578	1.0630	3.012	.38	3/8-24	.330	2.85	
		MB252-38-PA												2.61
		MB252-716-PA												
75	2 15/16	MB252-1516-PA	215	+0.0006-.0000	5.1181	2 17/64	.804	1.1835	3.632	.37	3/8-24	.266	3.96	
														6.76

† Bearing O.D. tolerance; 203 thru 208 basic size, +.0000" -.0005" (+0.000mm -0.013mm); 209 thru 215 basic size, +.0000"-.0006", +0.000mm -0.015mm).

Selection Guide – pages 4-6 & 37-39

Load Ratings – pages 40-41

Additional Information – page 42

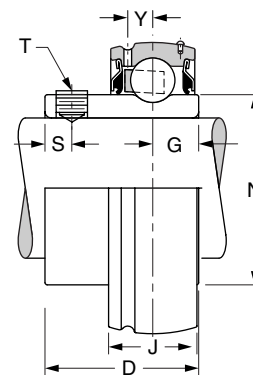
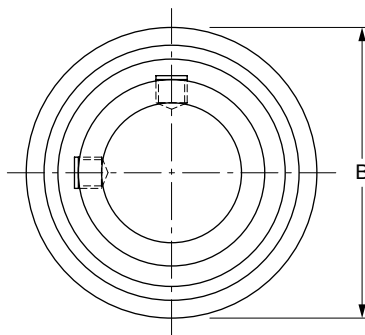

## MB35 MEDIUM DUTY SERIES BEARINGS ONLY with Concentric Setscrew Locking Device

Shaft Dia. Inches	Bearing Number	Basic Size	Bore Tolerance	B †	D	G	J	N	S	T Tap Size	Y	Unit wt. (lbs/kg)
1	MB351-PA	206	+.0005-.0000 +0.013-0.000	2.4409 62.000	1 11/32 34.14	.392 9.96	.7087 18.000	1.587 40.31	.31 7.9	1/4-28	.202 5.13	0.72 0.3
1 3/16	MB351-316-PA	207	+.0005-.0000 +0.013-0.000	2.8346 72.000	1 9/16 39.67	.454 11.53	.7480 19.000	1.847 46.91	.34 8.6	5/16-24	.227 5.77	1.03 0.5
1 7/16	MB351-716-PA	208	+.0005-.0000 +0.013-0.000	3.1496 80.000	1 21/32 42.06	.485 12.32	.8661 22.000	2.083 52.91	.34 8.6	5/16-24	.263 6.68	1.32 0.6
1 1/2	MB351-12-PA	209	+.0005-.0000 +0.013-0.000	3.3465 85.000	1 49/64 44.86	.532 13.51	.8661 22.000	2.281 57.94	.36 9.1	5/16-24	.256 6.50	1.62 0.7
1 11/16 1 3/4	MB351-1116-PA MB351-34-PA	210	+.0005-.0000 +0.013-0.000	3.5433 90.000	1 13/16 46.02	.532 13.51	.8661 22.000	2.475 62.86	.38 9.7	3/8-24	.256 6.50	1.82 0.8
1 15/16	MB351-1516-PA	211	+.0005-.0000 +0.013-0.000	3.9370 100.000	1 13/16 46.02	.537 13.64	.9843 25.000	2.749 69.82	.38 9.7	3/8-24	.298 7.57	2.36 1.1
2 3/16	MB352-316-PA	212	+.0006-.0000 +0.015-0.000	4.3307 110.000	1 57/64 48.03	.578 14.68	1.0630 27.000	3.012 76.50	.38 9.7	3/8-24	.330 8.38	2.97 1.3
2 7/16 2 1/2	MB352-716-PA MB352-12-PA	214	+.0010-.0000 +0.025-0.000	4.9213 125.000	2 15/64 56.74	.804 20.42	1.1545 29.324	3.433 84.58	.37 9.4	3/8-24	.266 6.76	4.39 1.9
2 11/16	MB352-1116-PA	215	+.0010-.0000 +0.025-0.000	5.1181 130.000	2 17/64 48.03	.804 20.42	1.1835 30.061	3.632 92.25	.37 9.4	3/8-24	.266 6.76	4.49 2.0
2 15/16 3	MB352-1516-PA MB353-PA	216	+.0010-.0000 +0.025-0.000	5.5118 140.000	2 23/64 59.92	.863 21.92	1.2575 31.940	3.920 99.57	.37 9.4	3/8-24	.282 7.16	5.53 2.4
3 3/16 3 7/16 3 1/2	MB353-316-PA MB353-716-PA MB353-12-PA	218	+.0010-.0000 +0.025-0.000	6.2992 160.000	2 33/64 63.91	.962 24.43	1.3945 35.420	4.396 111.66	.37 9.4	3/8-24	.313 7.95	8.23 7.34 3.3

† Bearing O.D. tolerance; 206 thru 208 basic size, +.0000" -.0005" (+0.000mm -0.013mm); 209 thru 215 basic size, +.0000" -.0006", +0.000mm -0.015mm); 216 and 218 basic size, +.0000" -.0008" (+0.000mm -0.020mm).

Selection Guide – pages 4-6 & 37-39  
Load Ratings – pages 40-41  
Additional Information – page 42

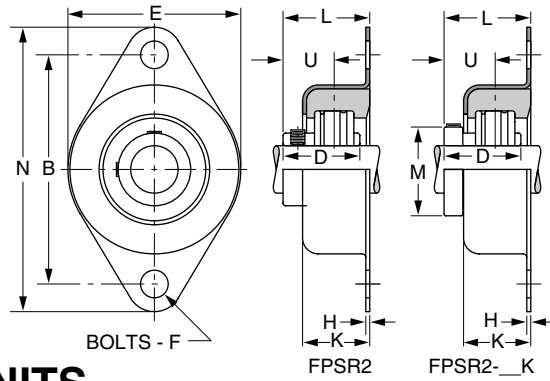

## RUBBER MOUNTED FLANGE UNITS

The rubber mounted bearing insert utilizes an oil resistant, conductive type, rubber adapter which is firmly supported circumferentially by the stamped steel 2-bolt mounting. The conductive rubber adapter is intended to alleviate electrical static charge build-up often encountered in some air moving equipment applications. The rubber supported bearing insert provides vibration dampening, which aids considerably in reducing noise level. These units are intended primarily for any light duty applications, such as fans, or blowers and are particularly well suited for heating, air conditioning and ventilating equipment where “quiet” installations are desirable. This would include any applications where any vibration or noise amplified by connecting duct work would be considered very objectionable.

The rubber mounted flange units are available in standard shaft sizes with the bolt hole size and spacing interchangeable with other competitive units. This does not mean the units are interchangeable in all respects with competition, but can be considered interchangeable in most instances. The units should be thoroughly compared if complete dimensional interchangeability is essential.

Shaft Dia. mm Inches	Flanged Unit Number		Basic Size	B	E	F	H	K	L	M	N	U	Radial Load Rating (lbs/newtons)	Unit wt. (lbs/kg)	Cartridge Unit Number		
	K-Lok	Centri-Lok													K-Lok	Centri-Lok	
20 1/2 5/8 3/4	FPSR2-12	FPSR2-12K	204	3 5/8	2 45/64	3/8	1/16	1 1/16	1 3/8	1 13/64	1 3/8	4 1/2	13/16	200	.73	RER8	RER8K
	FPSR2-58	FPSR2-58K														RER10	RER10K
	FPSR2-34	FPSR2-34K														RER12	RER12K
	FPSR2-204															RER204	RER204K
25 7/8 15/16 1	FPSR2-78	FPSR2-78K	205	3 5/8	2 45/64	3/8	1/16	1 1/16	1 25/64	1 9/16	4 1/2	55/64	250	.78	RER14	RER14K	
	FPSR2-1516	FPSR2-1516K													RER15	RER15K	
	FPSR21	FPSR21K													RER1	RER1K	
	FPSR2-205	FPSR2-205K													RER205	RER205K	
30 1 1/8 1 3/16 1 1/4	FPSR21-18	FPSR21-18K	206	4 3/8	3 1/2	7/16	1/16	1 1/4	1 5/8	1 13/16	2	5 3/8	29/32	300	1.47	RER18	RER18K
	FPSR21-316	FPSR21-316K														RER19	RER19K
	FPSR21-14S	FPSR21-14SK														RER20S	RER20SK
	FPSR21-206	FPSR21-206K														RER206	RER206K

Selection Guide – pages 4-6 & 37-39  
Additional Information – page 42

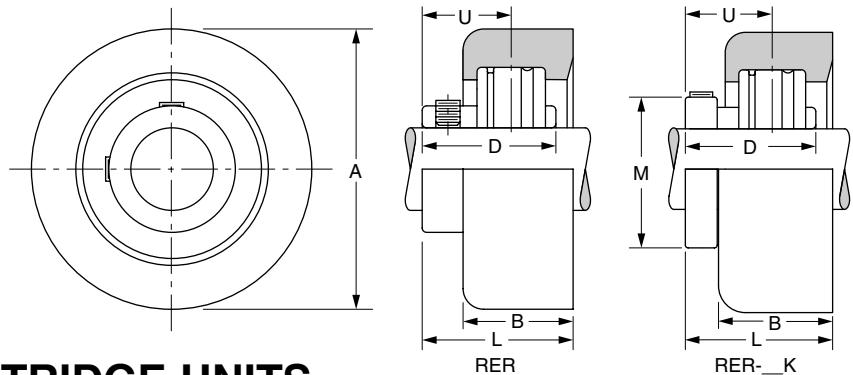

## RUBBER MOUNTED CARTRIDGE UNITS

Shaft Diameter		Cartridge Unit Number		Basic Size	A	B	L	M	U	Radial Load Ratings (lbs/newtons)	Unit wt. (lbs/kg)								
mm	Inches	K-Lok	Centri-Lok																
20	1/2 5/8 3/4	RER8	RER8K	204	2 17/32	1	1 3/8	1 13/64	13/16	200	.58								
		RER10	RER10K									64.3	25.4	34.9	30.6	20.6	890	.54	
		RER12	RER12K																.50
		RER204	RER204K																
25	7/8 15/16 1	RER14	RER14K	205	2 17/32	1	1 25/64	1 9/16	55/64	250	.58								
		RER15	RER15K									64.3	25.4	35.3	39.7	21.8	1110	.56	
		RER1	RER1K																.54
		RER205	RER205K																
30	1 1/8 1 3/16 1 1/4	RER18	RER18K	206	3 3/32	1 3/16	1 5/8	1 13/16	29/32	300	1.01								
		RER19	RER19K									78.6	30.2	41.3	50.8	23.0	1330	.97	
		RER20S	RER20SK																.92
		RER206	RER206K																

Selection Guide – pages 4-6 & 37-39  
Additional Information – page 42

# NOMENCLATURE

## Unmounted bearings with cylindrical O.D.

Symbol	Description	ER	12	K	-	FF	WO	JF	PB
ER	Adapter series - cylindrical O.D. with lube groove and O.D. locating ring	}	}	}	}	}	}	}	}
MSL	Cylindrical O.D. - wide inner ring - setscrew locking								
MSLN	Cylindrical O.D. - narrow inner ring - setscrew locking								
RER	Rubber cartridge unit (used in FPSR2 units)								
12	Shaft diameter in sixteenths of an inch		}						
204	Shaft diameter in one-fifth of a millimeter								
None	Setscrew locking - ER series only	}		}					
K	Centrik-Lok locking - ER series only								
-	Dash used as separator								
EDC	Bearing with riveted steel retainer and increased radial clearance					}			
STL	Bearing with riveted steel retainer and standard radial clearance								
XXXX	Seal options - See page 42								
WO	External locating ring omitted - ER series only								
XX	Non-standard grease designation								
PB	Bearing with 100% grease fill	}							}
PD	Bearing with preservative only								



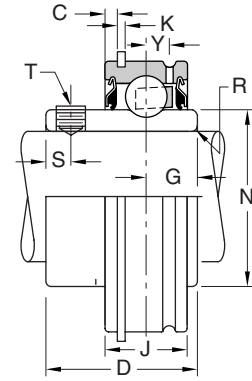
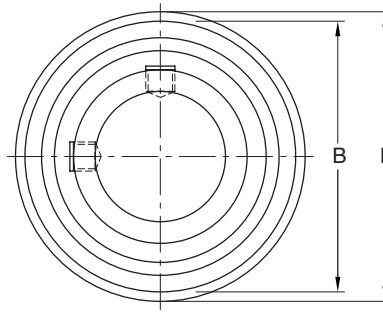

## ER ADAPTER SERIES BEARINGS ONLY with Concentric Setscrew Locking Device

Shaft Dia. mm	Inches	Bearing Number	Basic Size	Bore Tolerance	B	C	D	G	J	K	L	N	R	S	T Tap Size	Y	Unit wt. (lbs/kg)
20	1/2 5/8 3/4	ER8	204	+0.0007-.0000	1.8504	3/32	1 7/32	.405	.6240	3/64	2 1/16	.941	.040	15/64	#10-32	.142	0.62
		ER10		+0.018-0.000	47.000	2.4	30.96	10.29	15.850	1.2	52.4	23.90	1.0	2.0	#10-32	0.55	
		ER12		+0.018-0.000	47.000	2.4	30.96	10.29	15.850	1.2	52.4	23.90	1.0	2.0	1/4-28	0.54	
25	7/8 15/16 1	ER14	205	+0.0007-.0000	2.0472	3/32	1 3/8	.508	.7490	3/64	2 17/64	1.313	.040	15/64	1/4-28	.185	0.65
		ER15		+0.018-0.000	52.000	2.4	34.92	12.90	19.025	1.2	57.6	33.35	1.0	2.0	M6X1	0.63	
		ER16 ER205		+0.018-0.000	52.000	2.4	34.92	12.90	19.025	1.2	57.6	33.35	1.0	2.0	M6X1	0.61	
30	1 1/8 1 3/16 1 1/4	ER18	206	+0.0007-.0000	2.4409	3/32	1 1/2	.625	.8740	3/64	2 21/32	1.587	.040	1/4	1/4-28	.224	0.96
		ER19		+0.018-0.000	62.000	2.4	38.10	15.88	22.200	1.2	67.5	40.31	1.0	6.4	1/4-28	0.94	
		ER20S ER206		+0.018-0.000	62.000	2.4	38.10	15.88	22.200	1.2	67.5	40.31	1.0	6.4	M8X1.25	0.90	
35	1 1/4 1 3/8 1 7/16	ER20	207	+0.0008-.0000	2.8346	1/8	1 11/16	.688	.9365	1/16	3 5/64	1.847	.040	21/64	5/16-24	.256	1.75
		ER22		+0.020-0.000	72.000	3.2	42.88	17.48	23.787	1.6	78.2	46.91	1.0	8.3	M8X1.25	6.50	
		ER23		+0.020-0.000	72.000	3.2	42.88	17.48	23.787	1.6	78.2	46.91	1.0	8.3	M8X1.25	6.50	
40	1 1/2	ER24	208	+0.0008-.0000	3.1496	1/8	1 15/16	.750	1.0927	1/16	3 25/64	2.083	.062	3/8	5/16-24	.297	2.18
		ER208		+0.020-0.000	80.000	3.2	49.22	19.05	27.755	1.6	86.1	52.91	1.6	9.5	M8X1.25	7.54	
		ER26		+0.020-0.000	80.000	3.2	49.22	19.05	27.755	1.6	86.1	52.91	1.6	9.5	M8X1.25	7.54	
45	1 5/8 1 11/16 1 3/4	ER27	209	+0.0008-.0000	3.3465	1/8	1 15/16	.750	1.0927	1/16	3 19/32	2.281	.062	3/8	5/16-24	.297	2.28
		ER28		+0.020-0.000	85.000	3.2	49.22	19.05	27.755	1.6	91.3	57.94	1.6	9.5	M8X1.25	7.54	
		ER27		+0.020-0.000	85.000	3.2	49.22	19.05	27.755	1.6	91.3	57.94	1.6	9.5	M8X1.25	7.54	
50	1 7/8 1 15/16	ER30	210	+0.0008-.0000	3.5433	1/8	2 1/32	.750	1.1240	3/32	3 25/32	2.475	.062	3/8	3/8-24	.265	2.75
		ER31		+0.020-0.000	90.000	3.2	51.59	19.05	28.550	2.4	96.0	62.86	1.6	9.5	3/8-24	6.73	
		ER30		+0.020-0.000	90.000	3.2	51.59	19.05	28.550	2.4	96.0	62.86	1.6	9.5	M10X1.5	6.73	
55	2 2 3/16	ER32	211	+0.0009-.0000	3.9370	1/8	2 3/16	.875	1.1860	3/32	4 11/64	2.749	.080	3/8	3/8-24	.298	3.38
		ER35		+0.023-0.000	100.000	3.2	55.58	22.22	30.124	2.4	106.0	69.82	2.0	9.5	3/8-24	3.07	
		ER32		+0.023-0.000	100.000	3.2	55.58	22.22	30.124	2.4	106.0	69.82	2.0	9.5	M10X1.5	7.57	
60	2 1/4 2 3/8 2 7/16	ER36	212	+0.0009-.0000	4.3307	1/8	2 9/16	1.000	1.2490	3/32	4 9/16	3.012	.080	3/8	3/8-24	.330	4.48
		ER38		+0.023-0.000	110.000	3.2	65.07	25.4	31.725	2.4	115.9	76.50	2.0	9.5	3/8-24	4.38	
		ER39		+0.023-0.000	110.000	3.2	65.07	25.4	31.725	2.4	115.9	76.50	2.0	9.5	M10X1.5	4.19	
70	2 1/2 2 11/16	ER40	214	+0.0009-.0000	4.9213	5/32	2 3/4	1.062	1.3740	7/64	5 9/32	3.433	.080	3/8	3/8-24	.374	5.92
		ER43		+0.023-0.000	125.000	4.0	69.85	27.0	34.900	2.8	134.1	84.58	2.0	9.5	3/8-24	5.49	
		ER40		+0.023-0.000	125.000	4.0	69.85	27.0	34.900	2.8	134.1	84.58	2.0	9.5	M10X1.5	9.50	
75	2 7/8 2 15/16	ER46	215	+0.0009-.0000	5.1181	5/32	3 1/16	1.313	1.4990	7/64	5 1/2	3.632	.080	3/8	3/8-24	.374	6.60
		ER47		+0.023-0.000	130.000	4.0	77.77	33.32	38.075	2.8	139.7	92.25	2.0	9.5	3/8-24	6.37	
		ER46		+0.023-0.000	130.000	4.0	77.77	33.32	38.075	2.8	139.7	92.25	2.0	9.5	M10X1.5	9.50	
80	3 3 3/16	ER48	216	+0.0009-.0000	5.5118	5/32	3 1/4	1.313	1.6865	7/64	5 7/8	3.920	.120	3/8	3/8-24	.406	8.05
		ER51		+0.023-0.000	140.000	4.0	82.55	33.32	42.837	2.8	149.2	99.57	3.0	9.5	3/8-24	7.56	
		ER48		+0.023-0.000	140.000	4.0	82.55	33.32	42.837	2.8	149.2	99.57	3.0	9.5	M10X1.5	10.31	

†Bearing O.D. tolerance; 204 basic size, +.0000" -.0005" (+0.000mm -0.013mm); 205 thru 208 basic size, +.0000"-.0006", +0.000mm -0.015mm); 209 thru 212 basic size, +.0000" -.0008" (+0.000mm -0.020mm); 214 thru 216 basic size, +.0000" -.0010" (+0.000mm -0.025mm)

Selection Guide – pages 4-6 & 37-39  
Load Ratings – pages 40-41  
Additional Information – page 42

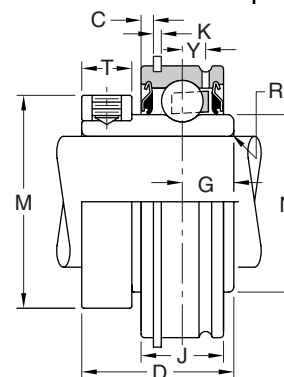
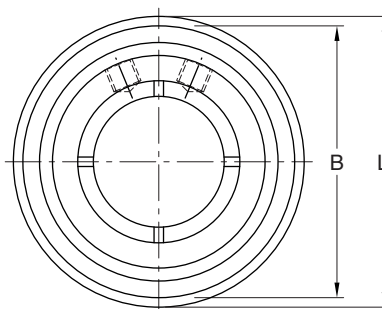

## ER ADAPTER SERIES BEARINGS ONLY with CENTRIK-LOK Locking Device

Shaft Dia. mm	Inches	Bearing Number	Basic Size	Bore Tolerance	B	C	D	G	J	K	L	N	R	S	T		Y	Unit wt. (lbs/kg)
															Width	Tap Size		
20	1/2 5/8 3/4	ER8K	204	+0.0007-.0000	1.8504	3/32	1 7/32	.405	.6240	3/64	2 1/16	.941	1 1/8	.040	9/32	#10-32	.142	0.62
		ER10K		+0.018-0.000	47.000	2.4	30.96	10.29	15.850	1.2	52.4	23.90	30.6	1.0	11/32	#10-32	3.61	0.55
		ER12K ER204K														8.7	M6X1	
25	7/8 15/16 1	ER14K	205	+0.0007-.0000	2.0472	3/32	1 3/8	.508	.7490	3/64	2 17/64	1.313	1 9/16	.040	11/32	1/4-28	.185	0.65
		ER15K		+0.018-0.000	52.000	2.4	34.92	12.90	19.025	1.2	57.6	33.35	39.7	1.0	8.7	M6X1	4.70	0.63
		ER16K ER205K																
30	1 1/8 1 3/16 1 1/4	ER18K	206	+0.0007-.0000	2.4409	3/32	1 1/2	.625	.8740	3/64	2 21/32	1.587	1 13/16	.040	7/16	1/4-28	.224	0.96
		ER19K		+0.018-0.000	62.000	2.4	38.10	15.88	22.200	1.2	67.5	40.31	50.8	1.0	11.1	M8X1.25	5.69	0.94
		ER20SK																
35	1 1/4 1 3/8 1 7/16	ER20K	207	+0.0008-.0000	2.8346	1/8	1 11/16	.688	.9365	1/16	3 5/64	1.847	2	.040	7/16	5/16-24	.256	1.75
		ER22K		+0.020-0.000	72.000	3.2	42.88	17.48	23.787	1.6	78.2	46.91	57.2	1.0	11.1	M8X1.25	6.50	1.70
		ER23K																
40	1 1/2	ER24K	208	+0.0008-.0000	3.1496	1/8	1 15/16	.750	1.0927	1/16	3 25/64	2.083	2 1/2	.062	7/16	5/16-24	.297	2.18
		ER208K		+0.020-0.000	80.000	3.2	49.22	19.05	27.755	1.6	86.1	52.91	63.5	1.6	11.1	M8X1.25	7.54	1.0
45	1 5/8 1 11/16 1 3/4	ER26K	209	+0.0008-.0000	3.3465	1/8	1 15/16	.750	1.0927	1/16	3 19/32	2.281	2 1/2	.062	7/16	5/16-24	.297	2.28
		ER27K		+0.020-0.000	85.000	3.2	49.22	19.05	27.755	1.6	91.3	57.94	68.3	1.6	11.1	M8X1.25	7.54	2.22
		ER28K																
50	1 7/8 1 15/16	ER30K	210	+0.0008-.0000	3.5433	1/8	2 1/32	.750	1.1240	3/32	3 25/32	2.475	2 7/8	.062	9/16	3/8-24	.265	2.75
		ER31K		+0.020-0.000	90.000	3.2	51.59	19.05	28.550	2.4	96.0	62.86	73.0	1.6	14.3	M10X1.5	6.73	2.61
55	2 2 3/16	ER32K	211	+0.0009-.0000	3.9370	1/8	2 3/16	.875	1.1860	3/32	4 11/64	2.749	2 7/8	.080	9/16	3/8-24	.298	3.38
		ER35K		+0.023-0.000	100.000	3.2	55.58	22.22	30.124	2.4	106.0	69.82	79.4	2.0	14.3	M10X1.5	7.57	3.07
60	2 1/4 2 3/8 2 7/16	ER36K	212	+0.0009-.0000	4.3307	1/8	2 9/16	1.000	1.2490	3/32	4 9/16	3.012	3 1/8	.080	9/16	3/8-24	.330	4.48
		ER38K		+0.023-0.000	110.000	3.2	65.07	25.4	31.725	2.4	115.9	76.50	85.7	2.0	14.3	M10X1.5	8.38	4.38
		ER39K																
70	2 1/2 2 11/16	ER40K	214	+0.0009-.0000	4.9213	5/32	2 3/4	1.062	1.3740	7/64	5 9/32	3.433	3 3/4	.080	9/16	3/8-24	.374	5.92
		ER43K		+0.023-0.000	125.000	4.0	69.85	27.0	34.900	2.8	134.1	84.58	95.2	2.0	14.3	M10X1.5	9.50	5.49
75	2 7/8 2 15/16	ER46K	215	+0.0009-.0000	5.1181	5/32	3 1/16	1.313	1.4990	7/64	5 1/2	3.632	4 3/16	.080	9/16	3/8-24	.374	6.60
		ER47K		+0.023-0.000	130.000	4.0	77.77	33.32	38.075	2.8	139.7	92.25	106.4	2.0	14.3	M10X1.5	9.50	6.37
80	3 3 3/16	ER48K	216	+0.0009-.0000	5.5118	5/32	3 1/4	1.313	1.6865	7/64	5 7/8	3.920	4 3/16	.120	9/16	3/8-24	.406	8.05
		ER51K		+0.023-0.000	140.000	4.0	82.55	33.32	42.837	2.8	149.2	99.57	106.4	3.0	14.3	M10X1.5	10.31	7.56

Bearing O.D. tolerance: 204 basic size, +.0000" -.0005" (+0.000mm -0.013mm); 205 thru 208 basic size, +.0000"-.0006", +0.000mm -0.015mm); 209 thru 212 basic size, +.0000" -.0008" (+0.000mm -0.020mm); 214 thru 216 basic size, +.0000" -.0010" (+0.000mm -0.025mm)

Selection Guide – pages 4-9  
Load Ratings – pages 40-41  
Additional Information – page 42



# ER TYPE BALL BEARING INSERTS

ER type bearing inserts are commonly used in mounted bearing assemblies. The bearings have basic standard metric ball bearing dimensions with the exception of widths and the inch size bore of the inner ring. Because of the metric ball bearing basis of design and sizing, the ball complement (the number and size) for a given size bearing is comparable with other manufacturers.

The ER type insert is designed for set screw locking to the shaft, with the bearing mounted in the customers housing. It incorporates standard seals and comes with a O.D. mounted snap ring for axial location, eliminating housing counterboring. ER series bearings are intended for rigid mounting, as the bearings have a cylindrical O.D. and not the spherical O.D. of standard insert bearings.

## ER SERIES HOUSING FITS for bearings with Concentric Setscrew or CENTRIK-LOK Locking Devices

BEARING NUMBER	OUTSIDE DIAMETER OF BEARING		ROTATING HOUSE				STATIONARY HOUSING			
	Min.	Max.	Diameter		Resultant Fit		Diameter		Resultant Fit	
			Min.	Max.	Loose	Tight	Min.	Max.	Loose	Tight
ER-8,9,10,11,12	1.8499	1.8540	1.8498	1.8504	.0005	.0006	1.8503	1.8509	.0010	.0001
ER-14,15,16	2.0466	2.0472	2.0466	2.0471	.0005	.0006	2.0471	2.0476	.0010	.0001
ER-17,18,19,20S	2.4403	2.4409	2.4403	2.4408	.0005	.0006	2.4408	2.4413	.0010	.0001
ER-20,21,22,23	2.8340	2.8346	2.8340	2.8345	.0005	.0006	2.8345	2.8350	.0010	.0001
ER-24,25	3.1490	3.1496	3.1490	3.1495	.0005	.0006	3.1495	3.1500	.0010	.0001
ER-26,27,28	3.3457	3.3465	3.3458	3.3464	.0007	.0007	3.3464	3.3470	.0013	.0001
ER-30,31	3.5425	3.5433	3.5426	3.5432	.0007	.0007	3.5432	3.5438	.0013	.0001
ER-32,34,35	3.9362	3.9370	3.9363	3.9369	.0007	.0007	3.9369	3.9375	.0013	.0001
ER-36,38,39	4.3299	4.3307	4.3300	4.3306	.0007	.0007	4.3306	4.3312	.0013	.0001
ER-40,43	4.9203	4.9213	4.9204	4.9212	.0009	.0009	4.9211	4.9219	.0016	.0002
ER-46,47	5.1171	5.1181	5.1172	5.1180	.0009	.0009	5.1179	5.1187	.0016	.0002
ER-48,51	5.5108	5.5118	5.5109	5.5117	.0009	.0009	5.5116	5.5124	.0016	.0002

The fit selections given will serve as a guide for the majority of applications where the bearings are subjected to normal loads and other normal operating conditions. When bearings are subjected to very heavy or vibratory loads, it may be necessary to employ shaft and housing fits tighter than standard. The same applies if shafts or housings of soft metal or those not having smoothly ground bearing seats (i.e., the smoothness ordinarily associated with ground or reamed bores) are used.

The bearing bore is made so that a sliding fit is produced on the shaft. For best results, a ground shaft should be used to obtain a snug fit. A light press fit is advisable for heavy loads or where dynamic balance is important. The following tolerances are recommended for nominal shaft diameters:

$$\begin{matrix} \text{Shaft} \\ \text{Diameter} \end{matrix} \left\{ \begin{matrix} 1/2\text{"}-115/16\text{" plus .0000 to minus .0005 \\ 2\text{"}-31/2\text{" plus .0000 to minus .0010 \end{matrix} \right.$$

These recommended shaft tolerances are for bearings applied under the load and speed conditions listed in the load rating tables. Consult Rexnord Bearing Products for extreme or special operating conditions.

Furthermore, if speeds are abnormally high, it may be necessary to maintain shaft and housing fits other than those shown in tables. Consult Rexnord Bearing Products engineering department for recommendation on any abnormal conditions.

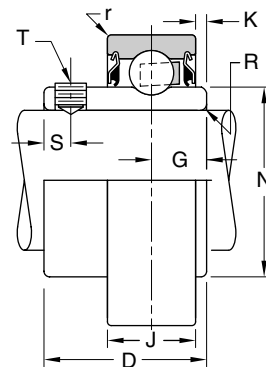
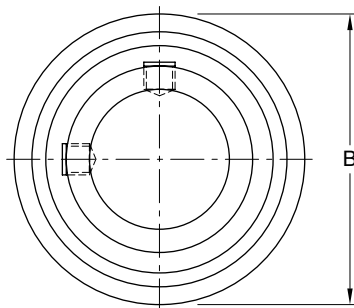

## MSL & MSLN SERIES BEARINGS with Cylindrical O.D.'s and Concentric Setscrew Locking Devices

Shaft Dia. Inches	Bearing Number		Basic Size	B †	D		G		J	K		N	r	R	S	T Tap Size	Unit wt. (lbs/kg)	
	Wide Series	Narrow Series			MSL	MSLN	MSL	MSLN		MSL	MSLN						MSL	MSLN
1/2 5/8	MSL8	MSLN8	203	1.5748	31/32	51/64	.391	.277	.5118	7/64	0.0	.941	.024	.024	3/16	#10-32	.24	0.22
	MSL10	MSLN10		40.000	24.61	20.24	9.93	7.04	13.000	2.9	0.0	23.90	0.61	0.61	4.8		0.1	0.1
3/4	MSL12	MSLN12	204	1.8504	1 5/32	15/16	.438	.294	.5906	9/64	0.0	1.121	.039	.039	3/16	#10-32	0.35	0.32
				47.000	29.36	23.82	11.12	7.47	15.000	3.6	0.0	28.47	1.00	1.00	4.8		0.2	0.1
1	MSL16	MSLN16	205	2.0472	1 7/32	15/16	.452	.309	.5906	9/64	0.0	1.313	.039	.039	7/32	1/4-28	.39	0.34
				52.000	30.94	23.82	11.48	7.85	15.000	3.6	0.0	33.35	1.00	1.00	5.6		0.2	0.2
1 1/4 1 3/8 1 7/16	MSL20	...	207	2.8346	1 17/32	...	.593	...	.7480	7/32	...	1.847	.039	.039	1/4	1/4-28	1.05	...
	MSL22	...		72.000	38.89	...	15.06	...	19.000	5.6	...	46.91	1.00	1.00	5.6		0.5	...
	MSL23	...		...	...	...	...	...	...	...	...	...	...	...	...		...	...

Bearing bore tolerance; 203 thru 207 basic size, +.0005" -.0000" (+0.013mm -0.000mm)

†Bearing O.D. tolerance; 203 and 204 basic size, +.0000" -.0005" (+0.000mm -0.013mm); 205 thru 207 basic size, +.0000" -.0006", +0.000mm -0.015mm)

Selection Guide – pages 4-6 & 37-39

Load Ratings – pages 40-41

Additional Information – page 42

These insert bearings have cylindrical O.D.'s.

They feature MB's traditional quality and precision and are recommended for general machinery applications.

The MSLN series has a narrow inner race which is flush with the outer race. The MSL series has an extended inner race on the non-locking side.

# STAMPED STEEL PILLOW BLOCKS AND FLANGETTES

Stamped steel pillow blocks, consisting of a two piece stamped steel housing with a spherical bearing seat to match the spherical radius ground on the bearing O.D. for light duty applications, provide the advantages of a ball bearing construction in an economical low cost unit. The base-to-shaft centerline height and bolt hole space of these units make them readily interchangeable with many standard mounting on the market.

All the stamped steel mounted units are easily adaptable to a variety of applications. The units are often used very successfully in application where the unit is selected for a given shaft size, for economic reasons, rather than for load rating. However, it should also be stressed that consideration should be given to the load rating and the unit should not be selected merely for the shaft size. The load rating is based on the strength of the specific stamped steel mounting rather than the bearing insert.

It is important that the inner ring set screws be tightened securely against the shaft before the stamped housing is attached (fastened) to the mounting surface. The self aligning feature of the stamping clamps the bearing O.D. when the mounting bolts are tightened and makes any additional alignment of the bearing insert within the mounting impractical.

Stamped steel flanges or flangettes consist of two interchangeable pressed steel flanges with spherical inside surfaces to form a mating contour to accommodate the spherical O.D. of the bearing insert. These are usually made in two, three and four bolt designs with standard mounting dimensions, or on a special basis to fit specific applications. They are low cost units for light duty and moderate speed applications.

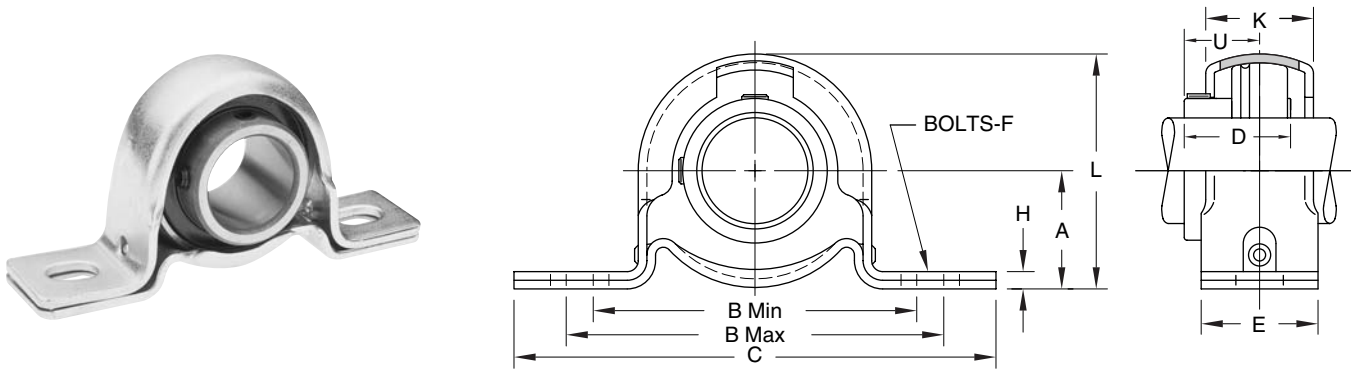

## PS25 SERIES STAMPED STEEL PILLOW BLOCKS

Shaft Dia.		Pillow Block Number	Basic Size	A	B		C	D	E	F	K	H	L	U	Radial load rating of housing assembly lbs/newtons	Unit wt. (lbs/kg)	Bearing Number
mm	Inches				Min.	Max.											
17	1/2 5/8 11/16	PS25-12 PS25-58 PS25-1116	203	7/8	2 1/2	2 7/8	3 5/8	63/64	1	5/16	.148	3/4	1 3/4	41/64	300	.50	MB25-12-WOPPA
				22.22	63.50	73.0	92.1	24.99	25.4	8	3.76	19.0	44.4	16.3	1340	.46 .44 0.2	MB25-58-WOPPA MB25-1116-WOPPA
20	3/4	PS25-34 PS25-20	204	1	2 7/8	3 1/8	4 1/8	1 1/8	1	3/8	.148	7/8	2 1/16	23/32	350	.63	MB25-34-WOPPA
				25.40	73.0	79.4	104.8	28.58	25.4	10	3.76	22.2	52.4	18.3	1560	0.3	MB25-20-WOPPA
25	7/8 15/16 1	PS25-78 PS25-1516 PS251 PS25-25	205	1 1/8	3 3/16	3 9/16	4 1/2	1 11/64	1 1/8	3/8	.208	3/4	2 7/32	3/4	400	.81	MB25-78-WOPPA
				28.58	81.0	90.5	114.3	29.77	28.6	10	5.28	19.0	56.4	19.0	1780	.78 .75 0.3	MB25-1516-WOPPA MB251-WOPPA MB25-25-WOPPA
30	1 1/8 1 3/16 1 1/4	PS251-18 PS251-316 PS251-14S PS25-30	206	1 5/16	3 9/16	3 15/16	4 7/8	1 11/32	1 1/8	3/8	.238	7/8	2 5/8	7/8	600	1.19	MB251-18-WOPPA
				33.32	90.5	100.0	123.8	34.14	28.6	10	5.28	22.2	66.7	22.2	2670	1.14 1.11 0.5	MB251-316-WOPPA MB251-14S-WOPPA MB25-30-WOPPA
35	1 1/4 1 3/8 1 7/16	PS251-14 PS251-38 PS251-716	207	1 9/16	3 15/16	4 7/16	5 3/4	1 9/16	1 1/4	1/2	.238	1	3 1/8	1	800	1.65	MB251-14-WOPPA
				39.67	100.0	112.7	146.0	39.67	31.8	12	5.28	25.4	79.4	25.4	3560	1.55 1.50 0.7	MB251-38-WOPPA MB251-716-WOPPA

Selection Guide – pages 4-6 & 37-39  
 Additional Information – page 42

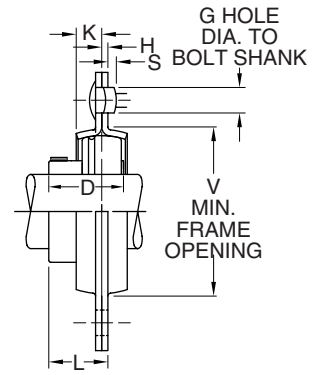
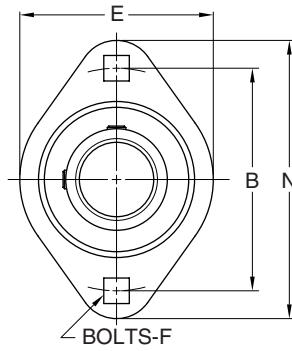

## FPS225 SERIES (2-BOLT) STAMPED STEEL FLANGE UNITS

Shaft Dia. mm   Inches	Flanged Unit Number	Basic Size	B	D	E	F		G	H			S Carriage Bolt		V	Radial load rating of housing assembly lbs/newtons	Unit wt. (lbs/kg)	Bearing Number	
						Carriage Bolt Size	Hole nominal ±.005" ±0.13 mm		Stock Thickness	K	L	N	Short Shank					Long Shank
17	FPS225-12	203	2 1/2	63/64	25/16	1/4	9/32	13/32	.075	9/32	23/32	33/16	.006	.100	1 15/16	600	.44 .40 .38 0.2	MB25-12-WOPPA MB25-58-WOPPA MB25-1116-WOPPA
	FPS225-58																	
	FPS225-1116																	
20	FPS225-34	204	2 13/16	1 1/8	25/8	5/16	11/32	1/2	.083	5/16	53/64	39/16	.021	.115	2 3/16	700	.57 0.3	MB25-34-WOPPA MB25-20-WOPPA
	FPS225-20																	
25	FPS225-78	205	3	1 11/64	2 61/64	5/16	11/32	1/2	.083	11/32	7/8	33/4	.021	.115	2 3/8	800	.73 .70 .67 0.3	MB25-78-WOPPA MB25-1516-WOPPA MB251-WOPPA MB25-25-WOPPA
	FPS225-1516																	
	FPS2251																	
30	FPS225-25	206	3 9/16	1 11/32	35/16	3/8	13/32	19/32	.104	11/32	1 1/16	47/16	.011	.104	2 13/16	1100	1.07 1.04 1.01 0.5	MB251-18-WOPPA MB251-316-WOPPA MB251-14S-WOPPA MB25-30-WOPPA
	FPS2251-18																	
	FPS2251-316																	
	FPS2251-14S																	
	FPS225-30																	

Selection Guide – pages 4-6 & 37-39  
 Additional Information – page 42

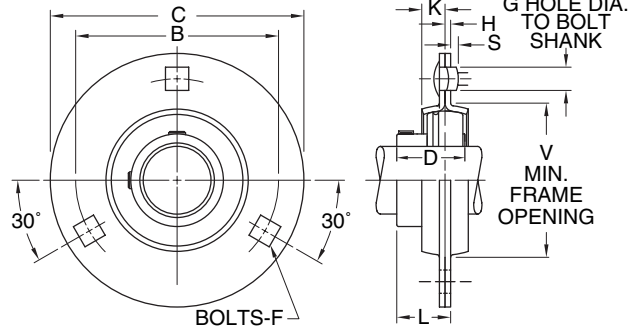

## FPS325 SERIES (3-BOLT) STAMPED STEEL FLANGE UNITS

Shaft Dia.	Flanged Unit Number	Basic Size	B	C	D	F		G	H		K	L	S		V	Radial load rating of housing assembly lbs/newtons	Unit wt. (lbs/kg)	Bearing Number
						Carriage Bolt Size	Hole nominal ±.005" ±0.13 mm		Stock Thickness	Short Shank			Long Shank					
mm	Inches																	
17	1/2 5/8 11/16	FPS325-12 FPS325-58 FPS325-1116	203	2 1/2	3 3/16	63/64	1/4	9/32	13/32	.075	9/32	23/32	.006	.100	1 15/16	600	.50 .46 .44 .02	MB25-12-WOPPA MB25-58-WOPPA MB25-1116-WOPPA
				63.5	81.00	24.99	...	7.14	10.3	1.90	7.1	18.3	...	...	49.2	2670		
20	3/4	FPS325-34 FPS325-20	204	2 13/16	3 9/16	1 1/8	5/16	11/32	1/2	.083	5/16	53/64	.021	.115	2 3/16	700	.76 .03	MB25-34-WOPPA MB25-20-WOPPA
				71.4	90.5	28.58	...	8.73	12.7	2.11	7.9	21.0	...	...	55.6	3110		
25	7/8 15/16 1	FPS325-78 FPS325-1516 FPS3251 FPS325-25	205	3	3 3/4	1 11/64	5/16	11/32	1/2	.083	11/32	7/8	.021	.115	2 3/8	800	.93 .90 .87 .04	MB25-78-WOPPA MB25-1516-WOPPA MB251-WOPPA MB25-25-WOPPA
				76.2	95.2	29.77	...	8.73	12.7	2.11	8.7	22.2	...	...	60.3	3560		
30	1 1/8 1 3/16 1 1/4	FPS3251-18 FPS3251-316 FPS3251-14S FPS325-30	206	3 9/16	4 7/16	1 11/32	3/8	13/32	19/32	.104	11/32	1 1/16	.011	.104	2 13/16	1100	1.39 1.36 1.33 0.6	MB251-18-WOPPA MB251-316-WOPPA MB251-14S-WOPPA MB25-30-WOPPA
				90.5	112.7	34.14	...	10.32	15.1	2.64	8.7	27.0	...	...	71.4	4890		
35	1 1/4 1 3/8 1 7/16	FPS3251-14S FPS3251-38 FPS3251-716	207	3 15/16	4 13/16	1 9/16	3/8	13/32	19/32	.104	3/8	1 7/32	.011	.104	3 3/16	1400	1.90 1.80 1.75 0.8	MB251-14-WOPPA MB251-38-WOPPA MB251-716-WOPPA
				100.0	122.2	39.67	...	10.32	15.1	2.64	9.5	31.0	...	...	81.0	6230		

Selection Guide – pages 4-6 & 37-39  
 Additional Information – page 42

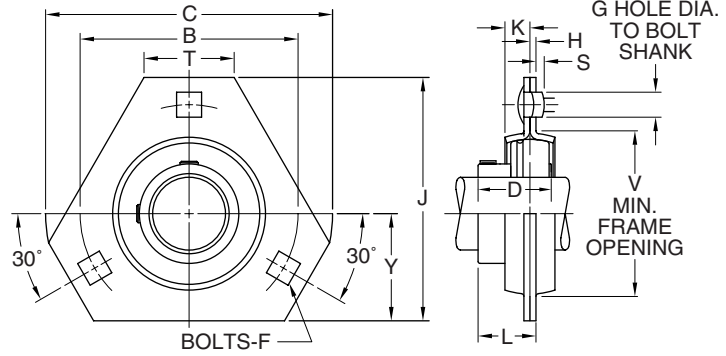

## TFPS325 SERIES (3-BOLT) STAMPED STEEL FLANGE UNITS

Shaft Dia. mm   Inches	Flanged Unit Number	Basic Size	B	C	D	F		G	H Stock Thickness	J	K	L	S Carriage Bolt		T	V	Y	Radial load rating of housing assembly lbs/newtons	Unit wt. (lbs/kg)	Bearing Number
						Carriage Bolt Size	Hole nominal ±.005" ±0.13 mm						Short Shank	Long Shank						
20   3/4	TFPS325-34 TFPS325-20	204	2 <sup>13/16</sup> 71.4	3 <sup>9/16</sup> 90.5	1 <sup>1/8</sup> 28.58	5/16 ...	1 <sup>1/32</sup> 8.73	1/2 12.7	.083 2.11	3 76.2	5/16 7.9	53/64 21.0	.021 ...	.115 ...	1 <sup>1/16</sup> 27.0	2 <sup>3/16</sup> 55.6	1 <sup>5/16</sup> 33.3	700 3110	.63 0.3	MB25-34-WOPPA MB25-20-WOPPA
25   7/8 15/16 1	TFPS325-78 TFPS325-1516 TFPS3251 TFPS325-25	205	3 76.2	3 <sup>3/4</sup> 95.2	1 <sup>11/64</sup> 29.77	5/16 ...	1 <sup>1/32</sup> 8.73	1/2 12.7	.083 2.11	3 <sup>5/32</sup> 80.2	1 <sup>1/32</sup> 8.7	7/8 22.2	.021 ...	.115 ...	1 <sup>7/64</sup> 28.2	2 <sup>3/8</sup> 60.3	1 <sup>3/8</sup> 34.9	800 3560	.79 .76 .73 0.3	MB25-78-WOPPA MB25-1516-WOPPA MB251-WOPPA MB25-25-WOPPA
30   1 1/8 1 3/16 1 1/4	TFPS3251-18 TFPS3251-316 TFPS3251-14S TFPS325-30	206	3 <sup>9/16</sup> 90.5	4 <sup>7/16</sup> 112.7	1 <sup>11/32</sup> 34.14	3/8 ...	1 <sup>3/32</sup> 10.32	1 <sup>9/32</sup> 15.1	.104 2.64	3 <sup>11/16</sup> 93.7	1 <sup>1/32</sup> 8.7	1 <sup>1/16</sup> 27.0	.011 ...	.104 ...	3 <sup>1/32</sup> 24.6	2 <sup>13/16</sup> 71.4	1 <sup>1/2</sup> 38.1	1100 4890	1.08 1.05 1.02 0.5	MB251-18-WOPPA MB251-316-WOPPA MB251-14S-WOPPA MB25-30-WOPPA

Selection Guide – pages 4-6 & 37-39  
Additional Information – page 42





# NOMENCLATURE

## Mounted units with Centrik-Lok locking feature

Symbol	Description	KFC2	45	1	-	716	-	FF	JF	Z
KC	Pillow block - standard backing - series 45/55	}	}	}	}	}	}	}	}	}
KCL	Pillow block - low backing - series 45/55									
KFC2	Flange unit - wide 2 bolt - series 45/55									
KFC4	Flange unit - wide 4 bolt square - series 45/55									
FC2	Flange unit - narrow 2 bolt - series 25/35									
FC4	Flange unit - narrow 4 bolt square - series 25/35									
PFC4	Piloted flange unit - 4 bolt - series 45/55									
45	Wide standard duty Krown Regal bearing	}	}	}	}	}	}	}	}	}
55	Wide medium duty Krown Regal bearing									
25K	Narrow standard duty bearing with Centrik-Lok									
35K	Narrow medium duty bearing with Centrik-Lok									
None	Shaft diameter less than 1 inch or a metric bore	}	}	}	}	}	}	}	}	}
1	Shaft diameter equal to or greater than 1 inch									
-	Dash used as separator									
716	Inch shaft fraction without the slash	}	}	}	}	}	}	}	}	}
35	Metric shaft size in millimeters									
-	Dash used to separate suffix from bore designation									
EDC	Bearing with riveted steel retainer and increased radial clearance	}	}	}	}	}	}	}	}	}
STL	Bearing with riveted steel retainer and standard radial clearance									
XXXX	Seal options - See page 12									
XX	Non-standard grease designation									
PB	Bearing with 100% grease fill	}	}	}	}	}	}	}	}	}
PD	Bearing with preservative only									
Z	Pipe plug in place of lube fitting									

# NOMENCLATURE

## Unmounted bearings with Centrik-Lok locking feature

Symbol	Description	KMB	45	1	-	716	-	FF	JF	PA
KMB	Ball bearing, spherical O.D. with lube groove and anti-rotation pin	}	}	}	}	}	}	}	}	}
45	Wide standard duty Krown Regal bearing									
55	Wide medium duty Krown Regal bearing									
25K	Narrow standard duty bearing with Centrik-Lok									
35K	Narrow medium duty bearing with Centrik-Lok									
None	Shaft diameter less than 1 inch or a metric bore									
1	Shaft diameter equal to or greater than 1 inch									
-	Dash used as separator									
716	Inch shaft fraction without the slash	}	}	}	}	}	}	}	}	}
35	Metric shaft size in millimeters									
-	Dash used to separate suffix from bore designation									
EDC	Bearing with riveted steel retainer and increased radial clearance	}	}	}	}	}	}	}	}	}
STL	Bearing with riveted steel retainer and standard radial clearance									
XXXX	Seal options - See page 12									
XX	Non-standard grease designation									
PA	Suffix designation for unmounted replacement bearing insert									

# NOMENCLATURE

## Mounted units with Setscrew locking feature

Symbol	Description	N	FC2	25	1	-	716	-	FF	JF	Z
N	Nickel plated housing, penetrated rings, food grade grease	}	}	}	}	}	}	}	}	}	}
C	Pillow block - standard backing										
CL	Pillow block - low backing										
FC2	Flange unit - 2 bolt mounting										
FC4	Flange unit - 4 bolt square mounting										
FPS2	Flange unit - formed steel housing - 2 bolt mounting										
FPS3	Flange unit - formed steel housing - 3 bolt round mounting										
FPSR2	Flange unit - formed steel housing - 2 bolt mounting with rubber mounted bearing insert										
MCHB	Screw conveyor hanger unit										
MEHB	Hanger unit										
MFB	Flange Bracket unit - 3 bolt mounting										
PFC4	Piloted flange unit - 4 bolt mounting										
PS	Pillow block - formed steel housing										
TBC	Pillow block - tapped base - 2 bolt mounting										
TC	Takeup unit - wide slot										
TCN	Takeup unit - narrow slot										
TPS3	Flange unit - formed steel hsg - 3 bolt triangular mounting										
25	Narrow standard duty bearing with Setscrew locking	}									
35	Narrow medium duty bearing with Setscrew locking										
None	Shaft diameter less than 1 inch or a metric bore	}									
1	Shaft diameter equal to or greater than 1 inch										
-	Dash used as separator										
716	Inch shaft fraction without the slash	}									
35	Metric shaft size in millimeters										
-	Dash used to separate suffix from bore designation										
EDC	Bearing with riveted steel retainer and increased radial clearance	}									
STL	Bearing with riveted steel retainer and standard radial clearance										
XXXX	Seal options - See page 42										
XX	Non-standard grease designation										
PB	Bearing with 100% grease fill	}									
PD	Bearing with preservative only										
Z	Pipe plug in place of lube fitting										

# NOMENCLATURE

## Unmounted bearings with Setscrew locking feature

Symbol	Description	MB	25	1	-	716	-	FF	JF	PA
MB	Ball bearing, spherical O.D. with lube groove and anti-rotation pin	}	}	}	}	}	}	}	}	}
25	Narrow standard duty bearing with Setscrew locking									
35	Narrow medium duty bearing with Setscrew locking									
None	Bore diameter less than 1 inch or a metric bore									
1	Bore diameter equal to or greater than 1 inch									
-	Dash used as separator									
716	Inch bore fraction without the slash									
35	Metric bore size in millimeters									
-	Dash used to separate suffix from bore designation									
EDC	Bearing with riveted steel retainer and increased radial clearance									
STL	Bearing with riveted steel retainer and standard radial clearance									
XXXX	Seal options - See page 42									
XX	Non-standard grease designation									
PA	Suffix designation for unmounted replacement bearing insert									

# PILLOW BLOCK COMPARISON CHARTS

The competitive manufacturers are listed in alphabetical order to provide a convenient source of unit substitution. This data is based on the shaft center height distances. This does not mean these competitive units are interchangeable in all respects. The bearings can be considered interchangeables in most instances, but should be checked if complete dimensional interchangeability is essential.

## MB Standard Duty Pillow Blocks with low shaft height

MB CL25 Shaft Dia.	Link-Belt PL3Y PL3U	Boston Gear		Browning		Dodge		Fafnir	SKF		Sealmaster		
		SL	L	PB200 PB220 PB250	VPLS	SCB SXB	VSCB	RAX TAX VAK	SYHP SYH-X	SYH-FM	NPL	RPL	VPL
1/2	2B08	1/2	3L-1/2	1/2	208	1/2		1/2	8	1/2	8	8	8
±9/16				9/16				9/16			9		
5/8	210	5/8	3L-5/8	5/8	210	5/8		5/8	10	5/8	10	10	10
11/16	211			11/16				11/16			11		
3/4	212	3/4	4L-3/4	3/4	212	3/4	3/4	3/4	12	3/4	12	12	12
±13/16													
±13/16 L				13/16				13/16	13	13/16	13	13	13
7/8	214	7/8	5L-7/8	7/8	214	7/8		7/8	14	7/8	14	14	14
15/16	215	15/16	5L-15/16	15/16	215	15/16		15/16	15	15/16	15	15	15
1	216	1	5L-1	1	216	1	1	1	100	1	16	16	16
±11/16				11/16				11/16	101	11/16	17		
11/8	218	11/8	6L-11/8	11/8	218	11/8		11/8	102	11/8	18	18	18
13/16	219	13/16	6L-13/16	13/16	219	13/16		13/16	103	13/16	19	19	19
11/4 S	2E20	11/4	6L-11/4	11/4	220S	11/4 (206)	11/4 (206)	11/4 S	104A	11/4 A	20R	20R	20R
11/4	220	11/4	7L-1/4	11/4	220	11/4 (207)	11/4 (207)	11/4	104	11/4	20	20	20
15/16	221	15/16	7L-5/16	15/16		15/16		15/16	105	15/16	21	21	21
13/8	222	13/8	7L-3/8	13/8	222	13/8		13/8	106	13/8	22	22	22
17/16	223	17/16	7L-7/16	17/16	223	17/16	17/16	17/16	107	17/16	23	23	23
11/2	224	11/2	8L-11/2	11/2	224	11/2	11/2	11/2	108		24	24	24
±19/16				19/16							25		
15/8						SCB15/8							
±15/8 L	226	15/8	9L-5/8	15/8	226	SXB15/8		15/8	110	15/8	26	26	26
111/16	227	111/16	9L-11/16	111/16	227	111/16		111/16	111	111/16	27	27	27
13/4	228	13/4	9L-3/4	13/4	228	13/4		13/4	112	13/4	28	28	28
±113/16													
±113/16 L				17/8				13/16			29		
17/8				17/8				17/8			30	30	30
115/16	231	115/16	10L-115/16	115/16	231	115/16	115/16	115/16	115	115/16	31	31	31
2	2E32					2	2	2S			32R	32R	32R
2 L	232	2	11L-2	2	232			2	200	2	32	32	32
±21/16								21/16					
21/8				21/8				21/8			34	34	34
23/16	235	23/16	11L-23/16	23/16	235	23/16	23/16	23/16	203	23/16	35	35	35
21/4						SCB21/4							
±21/4 L	236	21/4	12L-1/4	21/4	236	SXB21/4		21/4	204		36	36	
25/16								25/16					
23/8	239	27/16	12L-7/16	23/8	239	27/16		23/8	207		38	38	
27/16				27/16				27/16			39	39	
±25/8													
±211/16					243			211/16					
±23/4													
±213/16													
±27/8													
215/16				215/16*	247 * †			215/16					

†Not always available from stock. Consult Rexnord Bearing Products for availability.  
 \* Denotes variation in shaft center height distance.

# PILLOW BLOCK COMPARISON CHARTS (cont.)

The competitive manufacturers are listed in alphabetical order to provide a convenient source of unit substitution. This data is based on the shaft center height distances. This does not mean these competitive units are interchangeable in all respects. The bearings can be considered interchangeable in most instances, but should be checked if complete dimensional interchangeability is essential.

## MB Standard Duty Pillow Blocks

MB C25 Shaft Dia.	Link-Belt	Boston Gear		Browning		Dodge		Fafnir		SKF		Sealmaster		
	P3Y P3U	SH	H	PB201 PB221 PB251	VPS	SC SX	VSC	RAS TAS RASC VAS	SAS	SYP SY	SY-FM	NP	RP	VP
1/2 ±9/16 5/8 11/16	2B08 210 211	1/2 5/8	3H-1/2 3H-5/8	1/2 5/8 11/16	208 210	1/2†* 5/8†*		1/2 9/16 5/8 11/16	1/2 5/8	8 †* 10 †*		8 9 10 11	8 10	8 10
3/4 ±13/16	212	3/4	4H-3/4	3/4	212	3/4	3/4	3/4	3/4	12	3/4	12	12	12
±13/16 L 7/8 15/16 1	214 215 216	7/8 15/16 1	5H-7/8 5H-15/16 5H-1	13/16 7/8 15/16 1	214 215 216	7/8 15/16 1	1	13/16 7/8 15/16 1	7/8 15/16 1	13 14 15 100	13/16 7/8 15/16 1	13 14 15 16	14 15 16	14 15 16
±11/16 11/8 13/16 11/4 S	218 219 2E20	11/8 13/16 11/4	6H-1/8 6H-3/16 6H-1/4	11/16 11/8 13/16 11/4	218 219 220S	11/16* 11/8* 13/16* 11/4 (206)	13/16 11/4 (206)	11/16 11/8 13/16 11/4 S	11/8 13/16 11/4 S	101 102 103 104A	11/16 11/8 13/16 11/4 A	17 18 19 20R	18 19 20R	18 19 20R
11/4 15/16 17/8 17/16	220 221 222 223	11/4 15/16 13/8 17/16	7H-11/4 7H-15/16 7H-13/8 7H-17/16	11/4 15/16 13/8 17/16	220 222 223	11/4 (207) 15/16 13/8 17/16	11/4 (207) 17/16	11/4 15/16 13/8 17/16	11/4 13/8 17/16	104 105 106 107	11/4 15/16 13/8 17/16	20 21 22 23	20 22 23	20 22 23
11/2 ±19/16 15/8	224*	11/2*	8H-11/2*	11/2* 19/16*	224*	11/2 SC19/16	11/2	11/2†* 19/16†*	11/2†*	108†*	11/2†*	24†* 25†*	24†*	24†*
±15/8 L 111/16 13/4 ±113/16	226 227 228	15/8 111/16 13/4	9H-15/8 9H-111/16 9H-13/4	15/8 111/16 13/4	226 227 228	SX15/8 111/16 13/4		15/8 111/16 13/4	15/8 111/16 13/4	110 111 112	15/8 111/16 13/4	26 27 28	26 27 28	27 28
±113/16 L 17/8 115/16 2	231 2E32	115/16	10H-115/16	17/8 115/16	231	115/16 2	115/16 2	113/16 17/8 115/16 2S	115/16 2S	115	115/16	29 30 31 32R	30 31 32R	31 32R
2 L ±21/16 21/8 23/16 21/4	232 235	2 23/16	11H-2 11H-23/16	2 21/8 23/16	232 235	2 21/8 23/16 SC21/4	23/16	2 21/16 21/8 23/16	2 23/16	200 203	2 23/16	32 34 35	32 34 35	32 35
±21/4 L 25/16 23/8 27/16	236†* 239†*	21/4 27/16	12H-21/4 12H-27/16	21/4 23/8 27/16	236 239	SX21/4 27/16		21/4 25/16 23/8 27/16		204†* 207†*		36 38 39	36 38 39	
±25/8 ±211/16										211				
±23/4 ±213/16 ±27/8 215/16				215/16†*	247 †*	215/16		215/16		212* 215*				

†Not always available from stock. Consult Rexnord Bearing Products for availability.

\* Denotes variation is shaft center height distance.

† Use "CL-25" series equivalent bore size.

## MB Medium Duty Pillow Blocks

MB C35 Shaft Dia.	Boston Gear		Browning		Dodge	Sealmaster	
	MB		PB350	VPS	SCM	MP	VP
15/16 1			15/16 1	316*		15* 16*	16
13/16 ±11/4 S				319		19 20	19 20
17/16	17/16		17/16	323	17/16	23	23
11/2	11/2		11/2*	324*	11/2*	24*	24
111/16 13/4	111/16 13/4		111/16* 13/4*	327* 328*	111/16* 13/4*	27* 28*	27 28
115/16 2	115/16 2		115/16 2	331 332	115/16 2	31 32	31 32
23/16 21/4	23/16 21/4		23/16 21/4	335 336	23/16 21/4	35 36	35 36
27/16 21/2	27/16 21/2		27/16 21/2	339 340	27/16 21/2	39 40	39 40
211/16	211/16		211/16	343	211/16	43	43
215/16 3	215/16 3		215/16 3	347 348	215/16 3	47 48	47 48
33/16 37/16 31/2	33/16 37/16 31/2		37/16 31/2	355 356	37/16 31/2	51 55 56	55 56

†Not always available from stock. Consult Rexnord Bearing Products for availability.

\* Denotes variation is shaft center height distance.

## 2-BOLT FLANGE UNIT COMPARISON CHARTS

The competitive manufacturers are listed in alphabetical order to provide a convenient source of unit substitution. This data is based on the two most important dimensions – bolt hole size and bolt hole spacing. This does not mean these competitive units are interchangeable in all respects. The bearings can be considered interchangeable in most instances, but should be checked if complete dimensional interchangeability is essential.

### MB Standard Duty 2-Bolt Flange Units

MB FC225 Shaft Dia.	Link-Belt FX3Y FX3U	Boston Gear		Browning		Dodge		Fafnir		SKF		Sealmaster		
		ST	T	FB210 FB230 FB260	VF2S	SC SX	VSC	RCJTC RCJT TCJT VCJT	SCJT	FYTP	FYT-FM	SFT	RFT	VFT
1/2	2B08	1/2	3T-1/2	1/2	208	1/2		1/2	1/2	8		8	8	8
±9/16	210	5/8	3T-5/8	9/16	210	5/8		9/16	5/8	10		9	10	10
11/16	211			11/16				11/16				10	11	
3/4	212	3/4	4T-3/4		212	3/4	3/4	3/4	3/4	12	3/4	12	12	12
±13/16														
±13/16 L	214	7/8	5T-7/8	13/16	214	7/8		13/16	7/8	14	13/16	13	14	14
7/8	215	15/16	5T-15/16	7/8	215	15/16		7/8	15/16	15	7/8	14	15	15
15/16	216	1	5T-1	15/16	216	1	1	15/16	1	100	15/16	15	16	16
1				1				1			1	16	16	16
±11/16	218	11/8	6T-11/8	11/16	218	11/16		11/16	11/8	101	11/16	17	18	18
11/8	219	13/16	6T-13/16	11/8	219	13/16		11/8	13/16	102	11/8	18	19	19
13/16	2E20	11/4	6T-11/4	13/16	220S	11/4	11/4 (206)	13/16	11/4 S	103	13/16	19	20R	20R
11/4 S				11/4				11/4		104A	11/4 A	20R	20R	20R
11/4	220	11/4	7T-11/4	11/4	220	11/4 (207)	11/4 (207)	11/4	11/4	104	11/4	20	20	20
15/16	221	15/16	7T-15/16	15/16	222	15/16		15/16	15/16	105	15/16	21	22	22
13/8	222	13/8	7T-13/8	13/8	222	13/8		13/8	13/8	106	13/8	22	22	22
17/16	223	17/16	7T-17/16	17/16	223	17/16	17/16	17/16	17/16	107	17/16	23	23	23
11/2	224			11/2	224	11/2	11/2	11/2	11/2		11/2	24	24	24
±19/16				19/16				19/16				25		
15/8						SC15/8								
±15/8 L	226			15/8	226	SX15/8		15/8	15/8		15/8	26	26	26
111/16	227			111/16	227	111/16		111/16	111/16		111/16	27	27	26
13/4	228			13/4	228	13/4		13/4	13/4		13/4	28	28	27
±113/16														
±113/16 L								113/16 L				29	30	
17/8				17/8				17/8				30	31	31
115/16	231			115/16	231	115/16	115/16	115/16	115/16		115/16	31	32R	32R
2	2E32					2	2	2 S	2 S			32R	32R	32R
2 L	232			2	232			2			2	32	32	32
±21/16								21/16						
21/8	235			21/8	235			21/8	23/16		23/16	38	38	39
23/16				23/16				23/16				39	39	39
21/4														

‡Not always available from stock. Consult Rexnord Bearing Products for availability.

### MB Medium Duty 2-Bolt Flange Units

MB FC235 Shaft Size	Dodge SCM	Sealmaster MSFT
15/16		15
1		16
13/16		19
±11/4 S		20
17/16	17/16	23
11/2	11/2	24
111/16	111/16	27
13/4	13/4	28
115/16		31
2		32

‡Not always available from stock. Consult Rexnord Bearing Products for availability.

## 4-BOLT FLANGE UNIT COMPARISON CHARTS

The competitive manufacturers are listed in alphabetical order to provide a convenient source of unit substitution. This data is based on the two most important dimensions – bolt hole size and bolt hole spacing. This does not mean these competitive units are interchangeable in all respects. The bearings can be considered interchangeable in most instances, but should be checked if complete dimensional interchangeability is essential.

### MB Standard Duty 4-Bolt Flange Units

MB FC425 Shaft Dia.	Link-Belt F3Y F3U	Boston Gear		Browning		Dodge		Fafnir		SKF		Sealmaster		
		SF	F	FB200 FB220 FB250	VFLS	SC SX	VSC	RCJ TCJ RCJC VCJ	SCJ	FY FY-X FYP	FY-FM	SF	RF	VF
1/2 ‡9/16 5/8 11/16	2B08  210 211	1/2  5/8	3F-1/2  3F-5/8	1/2 9/16 5/8 11/16	208 210	1/2  5/8		1/2 9/16 5/8 11/16	1/2  5/8	8  10	1/2  5/8	8 9 10 11	8  10	8  10
3/4 ‡13/16	212	3/4	4F-3/4	3/4	212	3/4	3/4	3/4	3/4	12	3/4	12	12	12
‡13/16 L 7/8 15/16 1	214 215 216	7/8 15/16 1	5F-7/8 5F-15/16 5F-1	13/16 7/8 15/16 1	214 215 216	7/8 15/16 1	1	13/16 7/8 15/16 1	7/8 15/16 1	13 14 15 100	13/16 7/8 15/16 1	13 14 15 16	14 15 16	14 15 16
‡11/16 11/8 13/16 13/8 11/4 S	218 219 2E20	11/8 13/16 11/4	6F-11/8 6F-13/16 6F-11/4	11/16 11/8 13/16 11/4	218 219 220S	11/16 11/8 13/16 11/4 (206)	13/16 11/4 (206)	11/16 11/8 13/16 11/4 S	11/8 13/16 11/4 S	101 102 103 104A	11/16 11/8 13/16 11/4 A	17 18 19 20R	18 19 20R	18 19 20R
11/4 15/16 13/8 17/16	220 221 222 223	11/4 15/16 13/8 17/16	7F-11/4 7F-15/16 7F-13/8 7F-17/16	11/4 15/16 13/8 17/16	220 222 223	11/4 (207) 15/16 13/8 17/16	11/4 (207)  17/16	11/4 15/16 13/8 17/16	11/4 13/8 17/16	104 105 106 107	11/4 15/16 13/8 17/16	20 21 22 23	20 22 23	20 22 23
11/2 ‡19/16 15/8	224	11/2	8F-11/2	11/2 19/16	224	11/2	11/2	11/2 19/16	11/2	108	11/2	24 25	24	24
‡15/8 L 111/16 13/4 113/16	226 227 228	15/8 111/16 13/4	9F-15/8 9F-111/16 9F-13/4	15/8 111/16 13/4	226 227 228	SX15/8 111/16 13/4		15/8 111/16 13/4	15/8 111/16 13/4	110 111 112	15/8 111/16 13/4	26 27 28	26 27 28	27 28
‡113/16 L 17/8 115/16 2	231 2E32	115/16	10F-115/16	17/8 115/16	231	115/16 2	115/16 2	113/16 17/8 115/16 2 S	115/16 2	115	115/16	29 30 31 32R	30 31 32R	31 32R
2 L ‡21/16 21/8 23/16 21/4	232  235	2  23/16	11F-2  11F-23/16	2  21/8 23/16	232 235	  23/16 SC21/4	  23/16	2  21/8 23/16	  23/16	200 203	2  23/16	32 34 35	32 34 35	32 35
‡21/4 L 25/16 23/8 27/16	236  239	21/4  27/16	12F-21/4  12F-27/16	21/4  23/8 27/16	236 239	SX21/4  27/16		21/4 25/16 23/8 27/16		204 207		36 38 39	36 38 39	
‡25/8 ‡211/16	243				243			211/16		211		43		
‡23/4 ‡213/16 ‡27/8 215/16	244  247				247	215/16		215/16		212		46 47		

‡Not always available from stock. Consult Rexnord Bearing Products for availability.

# 4-BOLT PILOTED FLANGE UNIT COMPARISON CHARTS

This data is based on the three most important dimensions – piloted diameter, bolt circle diameter and bolt diameter. This does not mean these competitive units are interchangeable in all respects. The bearings can be considered interchangeable in most instances, but should be checked if complete dimensional interchangeability is essential.

## MB Medium Duty 4-Bolt Flange Units

MB FC425 Shaft Dia.	Boston Gear	Browning		Dodge	Fafnir	Sealmaster	
	MBF	PB350	VF4S	SCM	RCJO LCJO	MSF	MRF
1 <sup>5/16</sup> 1		1 <sup>5/16</sup> 1	316			15 16	16
1 <sup>3/16</sup> ±1 <sup>1/4</sup> S			319		1 <sup>3/16</sup>	19 20	19 20
1 <sup>7/16</sup> 1 <sup>1/2</sup>	1 <sup>7/16</sup> 1 <sup>1/2</sup>	1 <sup>7/16</sup> 1 <sup>1/2</sup>	323 324	1 <sup>7/16</sup> 1 <sup>1/2</sup>	1 <sup>7/16</sup> 1 <sup>1/2</sup>	23 24	23 24
1 <sup>11/16</sup> 1 <sup>3/4</sup>	1 <sup>11/16</sup> 1 <sup>3/4</sup>	1 <sup>11/16</sup> 1 <sup>3/4</sup>	327 328	1 <sup>11/16</sup> 1 <sup>3/4</sup>	1 <sup>11/16</sup> 1 <sup>11/16</sup>	27 28	27 28
1 <sup>15/16</sup> 2	1 <sup>15/16</sup> 2	1 <sup>15/16</sup> 2	331 332	1 <sup>15/16</sup> 2	1 <sup>15/16</sup>	31 32	31 32
2 <sup>3/16</sup> 2 <sup>1/4</sup>	2 <sup>3/16</sup> 2 <sup>1/4</sup>	2 <sup>3/16</sup> 2 <sup>1/4</sup>	335 336	2 <sup>3/16</sup> 2 <sup>1/4</sup>	2 <sup>3/16</sup>	35 36	35 36
2 <sup>7/16</sup> 2 <sup>1/2</sup>	2 <sup>7/16</sup> 2 <sup>1/2</sup>	2 <sup>7/16</sup> 2 <sup>1/2</sup>	339 340	2 <sup>7/16</sup> 2 <sup>1/2</sup>	2 <sup>7/16</sup>	39 40	39 40
2 <sup>11/16</sup>	2 <sup>11/16</sup>	2 <sup>11/16</sup>	343	2 <sup>11/16</sup>		43	43
2 <sup>15/16</sup> 3	2 <sup>15/16</sup> 3	2 <sup>15/16</sup> 3	347 348	2 <sup>15/16</sup> 3		47 48	47 48
3 <sup>3/16</sup> 3 <sup>7/16</sup> 3 <sup>1/2</sup>	3 <sup>3/16</sup> 3 <sup>7/16</sup> 3 <sup>1/2</sup>	3 <sup>3/16</sup> 3 <sup>7/16</sup> 3 <sup>1/2</sup>	355 356	3 <sup>7/16</sup> 3 <sup>1/2</sup>		51 55 56	55 56

‡Not always available from stock. Consult Rexnord Bearing Products for availability.  
\* Denotes variations in bolt hole size.

## MB Standard Duty 4-Bolt Piloted Flange Units

MB PFC425 Shaft Dia.	Dodge	Sealmaster
	SC	SFC
1 <sup>1/4</sup> 1 <sup>5/16</sup> 1 <sup>3/8</sup> 1 <sup>7/16</sup>	1 <sup>1/4</sup> 1 <sup>5/16</sup> 1 <sup>3/8</sup> 1 <sup>7/16</sup>	20 21 22 23
1 <sup>1/2</sup> 1 <sup>9/16</sup> 1 <sup>5/8</sup>	1 <sup>1/2</sup> 1 <sup>5/8</sup>	24 25
±1 <sup>5/8</sup> L 1 <sup>11/16</sup> 1 <sup>3/4</sup> 1 <sup>13/16</sup>		
±1 <sup>13/16</sup> L 1 <sup>7/8</sup> 1 <sup>15/16</sup> 2	1 <sup>15/16</sup> 2	30 31 32R
2 L ±2 <sup>1/16</sup> 2 <sup>1/8</sup> 2 <sup>3/16</sup> 2 <sup>1/4</sup>	2 <sup>3/16</sup> 2 <sup>1/4</sup>	32 34 35
±2 <sup>1/4</sup> 2 <sup>5/8</sup> 2 <sup>3/8</sup> 2 <sup>7/16</sup>	2 <sup>7/16</sup>	36 38 39
±2 <sup>5/8</sup> ±2 <sup>11/16</sup>		43
±2 <sup>3/4</sup> ±2 <sup>13/16</sup> ±2 <sup>7/8</sup> 2 <sup>15/16</sup>		46 47

‡Not always available from stock. Consult Rexnord Bearing Products for availability.

## MB Medium Duty 4-Bolt Piloted Flange Units

MB PFC425 Shaft Dia.	Boston Gear	Browning		Dodge	Fafnir	RHP (Pollard)	Sealmaster
	MBP	FC350	MFCS VFCS	SCM	RFC	MFC	MFC MRFC
1 <sup>3/16</sup> ±1 <sup>1/4</sup> S			319 320		1 <sup>3/16</sup>		19 20
1 <sup>7/16</sup> 1 <sup>1/2</sup>	1 <sup>7/16</sup> 1 <sup>1/2</sup>	1 <sup>7/16</sup> 1 <sup>1/2</sup>	323 324	1 <sup>7/16</sup> 1 <sup>1/2</sup>	1 <sup>7/16</sup> 1 <sup>1/2</sup>	1 <sup>7/16</sup> 1 <sup>1/2</sup>	23 24
1 <sup>11/16</sup> 1 <sup>3/4</sup>	1 <sup>11/16</sup> 1 <sup>3/4</sup>	1 <sup>11/16</sup> 1 <sup>3/4</sup>	327 328	1 <sup>11/16</sup> 1 <sup>3/4</sup>	1 <sup>11/16</sup> 1 <sup>3/4</sup>	1 <sup>11/16</sup> 1 <sup>3/4</sup>	27 28
1 <sup>15/16</sup> 2	1 <sup>15/16</sup> 2	1 <sup>15/16</sup> 2	331 332	1 <sup>15/16</sup> 2	1 <sup>15/16</sup>	1 <sup>15/16</sup> 2	31 32
2 <sup>3/16</sup> 2 <sup>1/4</sup>	2 <sup>3/16</sup> 2 <sup>1/4</sup>	2 <sup>3/16</sup> 2 <sup>1/4</sup>	335 336	2 <sup>3/16</sup> 2 <sup>1/4</sup>	2 <sup>3/16</sup>	2 <sup>3/16</sup> 2 <sup>1/4</sup>	35 36
2 <sup>7/16</sup> 2 <sup>1/2</sup>	2 <sup>7/16</sup> 2 <sup>1/2</sup>	2 <sup>7/16</sup> 2 <sup>1/2</sup>	339 340	2 <sup>7/16</sup> 2 <sup>1/2</sup>		2 <sup>7/16</sup> 2 <sup>1/2</sup>	39 40
2 <sup>11/16</sup>	2 <sup>11/16</sup>	2 <sup>11/16</sup>	343			2 <sup>11/16</sup>	43
2 <sup>15/16</sup> 3	2 <sup>15/16</sup> 3	2 <sup>15/16</sup> 3	347 348	2 <sup>15/16</sup> 3		2 <sup>15/16</sup> 3	47 48
3 <sup>3/16</sup> 3 <sup>7/16</sup> 3 <sup>1/2</sup>	3 <sup>7/16</sup> 3 <sup>1/2</sup>	3 <sup>7/16</sup> 3 <sup>1/2</sup>	355 356	3 <sup>7/16</sup> 3 <sup>1/2</sup>		3 <sup>7/16</sup> 3 <sup>1/2</sup>	55 56

‡Not always available from stock. Consult Rexnord Bearing Products for availability.

# TAKE-UP BLOCK COMPARISON CHARTS

The competitive manufacturers are listed in alphabetical order to provide a convenient source of unit substitution. This data is based on the three most important dimensions – hole size slot width and slot depth. This does not mean these competitive units are interchangeable in all respects. The bearings can be considered interchangeable in most instances, but should be checked if complete dimensional interchangeability is essential.

## MB Standard Duty Take-Up Blocks

MB TC25 Shaft Dia.	Link-Belt	Browning		Dodge	Fafnir	SKF		Sealmaster	
	TH3Y TH3U	WSTU220 WSTU250	MTWS VTWS	SC SX	RTU TU VTU	TB TBX TBP	TBY-FM	ST	RT
3/4 13/16	212	3/4	212	3/4	3/4	12	3/4	12	12
‡13/16 L 7/8 15/16 1	214 215 216	13/16 7/8 15/16 1	214 215 216	7/8 15/16 1	13/16 7/8 15/16 1	14 15 100	13/16 7/8 15/16 1	13 14 15 16	14 15 16
11/16 11/8 13/16 11/4 S	218 219 2E20	11/16 11/8 13/16	218 219	11/16 11/8 13/16 11/4 (206)	11/16 11/8 13/16	101 102 103 104A	11/16 11/8 13/16 11/4 A	17 18 19 20R	18 19 20R
11/4 15/16 13/8 17/16	220 221 222 223	11/4 15/16 13/8 17/16	220 222 223	11/4 (207) 15/16 13/8 17/16	11/4 15/16 13/8 17/16	104 105 106 107	11/4 15/16 13/8 17/16	20 21 22 23	20 22 23
11/2 19/16 15/8	224	11/2 19/16	224	11/2 SC15/8	11/2 19/16	108	11/2	24 25	24
‡15/8 L 111/16 13/4 113/16	226 227 228	15/8 111/16 13/4	226 227 228	SX15/8 111/16 13/4	15/8 111/16 13/4	110 111 112	15/8 111/16 13/4	26 27 28	26 27 28
113/16 L 17/8 115/16 2	231 2E32	17/8 115/16	231	115/16 2	113/16 17/8 115/16	115	115/16	29 30 31 32R	30 31 32R
2 ‡21/16 21/8 23/16 21/4	232 235	2 21/8 23/16	232 235	23/16 SC21/4	2 21/16 21/8 23/16	200 203	2 23/16	32 34 35	32 34 35
‡21/4 L 25/16 23/8 27/16	236 239	21/4 23/8 27/16	239	2X21/4 27/16	21/4 25/16 23/8 27/16	204 207		36 38 39	36 38 39
‡23/4 ‡213/16 ‡27/8 215/16				2	2	212 * 215 *		46 47	

‡Not always available from stock. Consult Rexnord Bearing Products for availability.  
\* Denotes variations in slot dimensions.



## TAKE-UP BLOCK COMPARISON CHARTS (cont.)

The competitive manufacturers are listed in alphabetical order to provide a convenient source of unit substitution. This data is based on the three most important dimensions – hole size slot width and slot depth. This does not mean these competitive units are interchangeable in all respects. The bearings can be considered interchangeable in most instances, but should be checked if complete dimensional interchangeability is essential.

### MB Medium Duty Take-Up Blocks

MB TC35 Shaft Dia.	Browning	Dodge	SKF	Sealmaster
	MTWS VTWS	SCM	TBYM-TM	MST
$1^{5/16}$ 1	316			15 16
$1^{9/16}$ $\pm 1^{1/4}$ S	319			19 20
$1^{7/16}$	323		$1^{7/16}$	23
$1^{1/2}$	324	$1^{1/2}$	$1^{1/2}$	24
$1^{11/16}$ $1^{3/4}$	327 328	$1^{11/16}$ $1^{3/4}$	$1^{11/16}$ $1^{3/4}$	27 28
$1^{15/16}$ 2	331 332	$1^{15/16}$ 2	$1^{15/16}$	31 32
$2^{3/16}$ $2^{1/4}$	335 336	$2^{3/16}$ $2^{1/4}$	$2^{3/16}$	35 36
$2^{7/16}$ $2^{1/2}$	339 340	$2^{7/16}$ $2^{1/2}$		39 40
$2^{11/16}$	343	$2^{11/16}$	$2^{11/16}$	43

‡Not always available from stock. Consult Rexnord Bearing Products for availability.

## SCREW CONVEYOR HANGER BEARING COMPARISON CHART

The competitive manufacturers are listed in alphabetical order to provide a convenient source of unit substitution. This data is based on the three most important decisions – inner race bore diameter, pipe thread size and “B” dimension on page 52. This does not mean these competitive units are interchangeable in all respects. The bearings can be considered interchangeable in most instances, but should be checked if complete dimensional interchangeability is essential.

MB MCHB	Equivalent Size			
	Dodge	Fafnir	RHP (Pollard) SCHBAG	Sealmaster
	SC SX	RHC RHC*	TBY-FM	SCHB
$\pm 1^{5/16}$ $\pm 1$ $\pm 1^{1/16}$ $\pm 1^{1/8}$ $\pm 1^{3/16}$ S $\pm 1^{1/4}$ S			1 $1^{1/16}$ $1^{1/8}$	15 16 18
$1^{3/16}$ $1^{1/4}$ $1^{5/16}$ $1^{3/8}$ $1^{7/16}$ S			$1^{3/16}$ $1^{1/4}$ $1^{5/16}$ $1^{3/8}$	19 20 21 22
$1^{7/16}$ $1^{1/2}$ $1^{9/16}$ $1^{5/8}$	$1^{1/2}$   $1^{5/8}$	$1^{1/2}$   $1^{5/8}$	$1^{7/16}$ $1^{1/2}$ $1^{9/16}$	23 24 25
$1^{11/16}$ $1^{3/4}$ $1^{7/8}$ $1^{15/16}$ 2	   $1^{15/16}$ 2	   $1^{15/16}$ 2*	$1^{11/16}$ $1^{3/4}$ $1^{7/8}$ $1^{15/16}$ 2	27 28 30 31 32
$2^{3/16}$ $2^{1/4}$ $2^{5/16}$ $2^{3/8}$ $2^{7/16}$	    $2^{7/16}$	    $2^{7/16}$ *	$2^{3/16}$ $2^{1/4}$  $2^{3/8}$ $2^{7/16}$	35 36  38 39
$\pm 2^{11/16}$ $\pm 2^{3/4}$ $\pm 2^{7/8}$ $\pm 2^{15/16}$			$2^{11/16}$ $2^{3/4}$ $2^{7/8}$ $2^{15/16}$	43 46 47
$2^{15/16}$ L 3 $\pm 3^{3/16}$ S	$2^{15/16}$ 3		3 $3^{3/16}$	48 51 R
$3^{3/16}$ $3^{7/16}$ $3^{1/2}$				

‡Not always available from stock. Consult Rexnord Bearing Products for availability.

## TAPPED BASE PILLOW BLOCK COMPARISON CHARTS

The competitive manufacturers are listed in alphabetical order to provide a convenient source of unit substitution. This data is based on the two most important dimensions – shaft center eheight distances and tapped bolt hole centers. This does not mean these competitive units are interchangeable in all respects. The bearings can be considered interchangeable in most instances, but should be checked if complete dimensional interchangeability is essential.

### Tapped Base Comparison Chart

MB TBC25 Shaft Dia.	Browning		Sealmaster	
	TPB250	MTBS VTBS	TB	RTB
1/2		208	8	8
±9/16			9	
5/8	5/8	210	10	10
±11/16			11	
3/4	3/4	212	12	12
±13/16				
7/8		214	14	14
±15/16	15/16	215	15	15
1	1	216	16	16
±11/16			17	
1 1/8		218	18	18
±13/16	13/16	219	19	19
1 1/4 S	1 1/4	220S	20R	20R
1 1/4	1 1/4	220	20	20
±15/16			21	
1 3/8	1 3/8	222	22	22
±17/16	17/16	223	23	23
1 1/2	1 1/2	224	24	24
±19/16			25	
±15/8				
1 5/8 L		226	26	26
±111/16		227	27	27
1 3/4	1 3/4	228	28	28
±113/16				
±113/16 L			30	30
1 7/8			31	31
±115/16	1 15/16	231	32R	32R
2		232S		
2 L	2			

‡Not always available from stock. Consult Rexnord Bearing Products for availability.

### MEHB Series Bearing Comparison Chart

MB MEHB Shaft Dia.	Dodge	RHP (Pollard)	Sealmaster
	SC SX	SCHBAG	SEHB
15/16			15
1		1	16
±11/16		1 1/16	
1 1/8		1 1/8	18
1 3/16 S			
1 1/4 S			
13/16		13/16	19
1 1/4		1 1/4	20
±15/16		15/16	21
1 3/8		1 3/8	22
1 7/16 S			
17/16		17/16	23
1 1/2	1 1/2	1 1/2	24
±19/16		1 9/16	25
±15/8	15/8		
1 11/16		1 11/16	27
1 3/4		1 3/4	28
±17/8		1 7/8	30
1 15/16	1 15/16	1 15/16	31
2	2		32
23/16		23/16	35
2 1/4		2 1/4	36
±25/16			
2 3/8		2 3/8	38
±27/16	27/16	27/16	39
±211/16		2 11/16	43
±23/4		2 3/4	46
±27/8		2 7/8	47
±215/16		2 15/16	
2 15/16 L	2 15/16		48
3	3	3	51R
±33/16 S			

‡Not always available from stock. Consult Rexnord Bearing Products for availability.

## MFB SERIES 3-BOLT FLANGE BRACKET COMPARISON CHARTS

The competitive manufacturers are listed in alphabetical order to provide a convenient source of unit substitution. This data is based on the three most important dimensions – shaft centerline location, bolt hole size and bolt hole spacing. This does not mean these competitive units are interchangeable in all respects. The bearings can be considered interchangeable in most instances, but should be checked if complete dimensional interchangeability is essential.

### MFB Series Flange Comparison Chart

MB MFB Shaft Dia.	Sealmaster
	FB
±1/2	8
±9/16	9
±5/8	10
±11/16	11
3/4	12
7/8	14
±15/16	15
1	16
±11/16	17
1 1/8	18
1 3/16	19
1 1/4	20R
1 1/4	20
±15/16	21
1 3/8	22
±17/16	23

‡Not always available from stock. Consult Rexnord Bearing Products for availability.

## FPSR2 RUBBER MOUNTED FLANGE UNIT COMPARISON

The competitive manufacturers are listed in alphabetical order to provide a convenient source of unit substitution. This data is based on the two most important dimensions – bolt hole size and bolt hole spacing. This does not mean these competitive units are interchangeable in all respects. The bearings can be considered interchangeable in most instances, but should be checked if complete dimensional interchangeability is essential.

### FPSR2 Rubber Mounted Flange

MB FPSR2 and FPSR2-K Shaft Size	Sealmaster SRF
1/2	8
5/8	10
3/4	12
7/8	14
15/16	15
1	16
±1 1/16	17
1 1/8	18
1 3/16	19
1 1/4 S	20R

‡Not always available from stock. Consult Rexnord Bearing Products for availability.

## RER RUBBER MOUNTED CARTRIDGE UNIT COMPARISON

The competitive manufacturers are listed in alphabetical order to provide a convenient source of unit substitution. This data is based on the O.D. of the rubber cartridge. This does not mean these competitive units are interchangeable in all respects. The bearings can be considered interchangeable in most instances, but should be checked if complete dimensional interchangeability is essential.

### RER Rubber Mounted Cartridge Unit

Shaft Size	MB RER and RER-K Number	Sealmaster SRC
1/2	8	8
5/8	10	10
3/4	12	12
7/8	14	14
15/16	15	15
1	16	16
±1 1/16	17	17
1 1/8	18	18
1 3/16	19	19
1 1/4 S	20 S	20R

‡Not always available from stock. Consult Rexnord Bearing Products for availability.

## STAMPED STEEL PILLOW BLOCK COMPARISON CHARTS

All numbers listed are complete assembled unit numbers unless noted with (\*) which indicates the numbers represent stamped housing number followed by the shaft diameter.

MB PS25 Shaft Size	Aetna EPT-UL*	BCA SPB*	Boston Gear PS	Dodge SL	Fafnir PB	RHP (Pollard) LPB	SKF TBY-FM	Sealmaster SSP
1/2		1/2	1/2		1/2	1/2	1/2	
9/16		9/16			9/16	9/16		
5/8		5/8	5/8		5/8	5/8	5/8	
11/16						11/16		
3/4	011-3/4	3/4	3/4	3/4	3/4	3/4	3/4	
±13/16								
±13/16 L	013-13/16	13/16	13/16		13/16	13/16	13/16	14
7/8	013-7/8	7/8	7/8	7/8	7/8	7/8	7/8	15
15/16	013-15/16	15/16	15/16	15/16	15/16	15/16	15/16	16
1	013-1	1	1	1	1	1	1	
±1 1/16	101-1/16	1 1/16	1 1/16		1 1/16	1 1/16	1 1/16	18
1 1/8	101-1/8	1 1/8	1 1/8	1 1/8	1 1/8	1 1/8	1 1/8	19
1 3/16	101-3/16	1 3/16	1 3/16	1 3/16	1 3/16	1 3/16	1 3/16	20 R
1 1/4 S	101-1/4	1 1/4	1 1/4 S	1 1/4	1 1/4 S	1 1/4	1 1/4 A	

‡Not always available from stock. Consult Rexnord Bearing Products for availability.

## STAMPED STEEL 2-BOLT FLANGE UNIT COMPARISON CHARTS

All numbers listed are complete assembled unit numbers unless noted with (\*) which indicates the numbers represent stamped housing number followed by the shaft diameter.

MB FPS25 Shaft Size	Link-Belt MST*	Aetna EPT-MST*	BCA MST*	Boston Gear PS2	Dodge SL	Fafnir RAT	New Departure FL-2*	RHP (Pollard) SLFL	SKF FT-FM	Sealmaster SSFT
1/2	40-1/2	0040-1/2	40-1/2	1/2		1/2	40-1/2	1/2	1/2	8
9/16	40-9/16	0040-9/16	40-9/16				40-9/16	9/16		
5/8	40-5/8	0040-5/8	40-5/8	5/8		5/8	40-5/8	5/8	5/8	10
11/16	40-11/16						40-11/16	11/16		
3/4	47-3/4	0047-3/4	47-3/4	3/4	3/4	3/4	47-3/4	3/4	3/4	12
±13/16										
±13/16 L	52-13/16	0052-13/16	52-13/16				52-13/16	13/16	13/16	14
7/8	52-7/8	0052-7/8	52-7/8	7/8	7/8	7/8	52-7/8	7/8	7/8	15
15/16	52-15/16	0052-15/16	52-15/16	15/16	15/16	15/16	52-15/16	15/16	15/16	16
1	52-1	0052-1	52-1	1	1	1	52-1	1	1	
±1 1/16	62-1/16	0062-1/16	62-1/16	1 1/16		1 1/16		1 1/16	1 1/16	18
1 1/8	62-1/8	0062-1/8	62-1/8	1 1/8	1 1/8	1 1/8		1 1/8	1 1/8	19
1 3/16	62-13/16	0062-3/16	62-3/16	1 3/16	1 3/16	1 3/16		1 3/16	1 3/16	20 R
1 1/4 S	62-1/4	0062-1/4	62-1/4	1 1/4 S	1 1/4	1 1/4 S		1 1/4 S	1 1/4 A	

‡Not always available from stock. Consult Rexnord Bearing Products for availability.

## STAMPED STEEL 3-BOLT FLANGE UNIT COMPARISON CHARTS

MB FPS325 Shaft Size	Link-Belt	Aetna	BCA	Boston Gear	Dodge	Fafnir	New Departure	RHP (Pollard)	SKF	Sealmaster
	MSC1*	EPT-MS-C1*	MS*	PS3	SL	RA	FL*	SLFE	F-FM	SSF
1/2 ‡9/16 5/8 11/16	40-1/2  40-5/8 40-11/16	0040-1/2 0040-9/16 0040-5/8	40-1/2 40-9/16 40-5/8	1/2  5/8		1/2 9/16 5/8	40-1/2 40-9/16 40-5/8 40-11/16	1/2 9/16 5/8 11/16	1/2  5/8	
3/4 ‡13/16	47-3/4	0047-3/4	47-3/4	3/4	3/4	3/4	47-3/4	3/4	3/4	12
‡13/16 L 7/8 15/16 1	52-7/8 52-15/16 52-1	0052-13/16 L 0052-7/8 0052-15/16 0052-1	52-13/16 L 52-7/8 52-15/16 52-1	7/8 15/16 1	7/8 15/16 1	13/16 7/8 15/16 1	52-13/16 L 52-7/8 52-15/16 52-1	13/16 7/8 15/16 1	13/16 7/8 15/16 1	14 15 16
‡11/16 11/8 13/16 11/4 S	62-11/8 62-13/16 62-11/4	0062-11/16 0062-1/8 0062-3/16 0062-1/4	62-11/16 62-11/8 62-13/16 62-11/4	11/8 13/16 11/4 S	11/8 13/16 11/4	11/16 11/8 13/16 11/4 S	62-11/16 62-11/8 62-13/16 62-11/4	11/16 11/8 13/16 11/4	11/16 11/8 13/16 11/4 A	18 19 20 R
11/4 15/16 13/8 17/16	72-11/4 72-15/16 72-13/8 72-17/16		72-11/4 72-15/16 72-13/8 72-17/16	11/4 15/16 13/8 17/16		11/4 15/16 13/8 17/16	72-11/4 72-15/16 72-13/8 72-17/16	15/16 13/8 17/16	11/4 15/16 13/8 17/16	20 21 22 23

‡Not always available from stock. Consult Rexnord Bearing Products for availability.

All numbers listed are complete assembled unit numbers unless noted with (\*) which indicates the numbers represent stamped housing number followed by the shaft diameter.

## STAMPED STEEL 3-BOLT TRIANGULAR FLANGE UNIT COMPARISON CHARTS

MB TFPS325 Shaft Size	Link-Belt	BCA	Fafnir	New Departure	Sealmaster
	MSTR*	MSTR*	RATR	FL-3*	TSSF
3/4 ‡13/16	47-3/4	47-3/4	3/4		12
‡13/16 L 7/8 15/16 1	52-7/8 52-15/16 52-1	52-13/16 L 52-7/8 52-15/16 52-1	7/8 15/16 1		14 15 16
‡11/16 11/8 13/16 11/4 S	62-11/8 62-13/16 62-11/4	62-11/16 62-11/8 62-13/16 62-11/4	11/16 11/8 13/16 11/4 S	62-11/16 62-11/8 62-13/16 62-11/4	18 19 20 R

‡Not always available from stock. Consult Rexnord Bearing Products for availability.

All numbers listed are complete assembled unit numbers unless noted with (\*) which indicates the numbers represent stamped housing number followed by the shaft diameter.

# ADAPTER BEARING COMPARISON CHARTS

The competitive manufacturers are listed in alphabetical order to provide a convenient source of unit substitution. This data is based on the two most important dimensions – inner race bore and outer race O.D. This does not mean these competitive units are interchangeable in all respects. The bearings can be considered interchangeable in most instances, but should be checked if complete dimensional interchangeability is essential.

MB Bearing No. ER*ER-K	MB Bearing No. ER*ER-K	Shaft Dia.	Browning	Fafnir	Federal	MRC	Roberts	SKF	Sealmaster
ER-8 ‡ER-9 ER-10 ‡ER-11 ER-12	ER-8 ER-9 ER-10 ER-11 ER-12	1/2 9/16 5/8 11/16 3/4	MER-208 MER-209 MER-210 MER-211 MER-212	ER-8 ER-10 ER-12	WR-08 WR-09 WR-10 WR-11 WR-12	ER-8 ER-10 ER-12	NGA-8 NGA-10L NGA-12L	NER-10 NER-12	ER-8 ER-9 ER-10 ER-11 ER-12
ER-14 ER-15 ER-16	ER-14 ER-15 ER-16	7/8 15/16 1	MER-214 MER-215 MER-216	ER-14 ER-15 ER-16	WR-14 WR-15 WR-16	ER-16	NGA-10 NGA-12 NGA-14 NGA-15 NGA-16	NER-14 NER-16	ER-14 ER-15 ER-16
‡ER-17 ER-18 ER-19 ER-20S	ER-17 ER-18 ER-19 ER-20S	11/16 1 1/8 1 3/16 1 1/4	MER-217 MER-218 MER-219	ER-18 ER-19	WR-17 WR-18 WR-19	ER-19	NGA-18 NGA-19 NGA-20A	NER-18 NER-19	ER-17 ER-18 ER-19
ER-20 ‡ER-21 ER-22 ER-23	ER-20 ER-21 ER-22 ER-23	1 1/4 1 5/16 1 3/8 1 7/16	MER-220 MER-221 MER-222 MER-223	ER-20 ER-22 ER-23	WR-20 WR-21 WR-22 WR-23	ER-20 ER-22 ER-23	NGA-20H NGA-21 NGA-22 NGA-23 NGA-24L	NER-20 NER-22 NER-23	ER-20 ER-21 ER-22 ER-23
ER-24 ER-25	ER-24 ER-25	1 1/2 1 9/16	MER-224 MER-225	ER-24	WR-24 WR-25	ER-24		NER-24	ER-24 ER-25
ER-26 ER-27 ER-28	ER-26 ER-27 ER-28	1 5/8 1 11/16 1 3/4	MER-226 MER-227 MER-228	ER-27 ER-28	WR-26 WR-27 WR-28				ER-26 ER-27 ER-28
ER-30 ER-31	ER-30 ER-31	1 7/8 1 15/16	MER-230 MER-231	ER-30 ER-31	WR-30 WR-31				ER-30 ER-31
ER-32 ER-34 ER-35	ER-32 ER-34 ER-35	2 2 1/8 2 3/16	MER-232 MER-234 MER-235	ER-32 ER-35	WR-32 WR-34 WR-35	ER-32 ER-34			ER-32 ER-34 ER-35
ER-36 ER-38 ER-39	ER-36 ER-38 ER-39	2 1/4 2 9/8 2 7/16		ER-39	WR-36 WR-38 WR-39				ER-36 ER-38 ER-39
ER-40 ER-43	ER-40 ER-43	2 1/2 2 11/16			WR-40 WR-43				ER-40 ER-43
ER-46 ER-47	ER-46 ER-47	2 7/8 2 15/16		ER-47	WR-46 WR-47				ER-46 ER-47
ER-48 ER-51	ER-48 ER-51	3 3 3/16			WR-48 WR-51				ER-48 ER-51

‡Not always available from stock. Consult Rexnord Bearing Products for availability.



## World Class Customer Service

For over 100 years the dedicated people of Rexnord have delivered excellence in quality and service to our customers around the globe. Rexnord is a trusted name when it comes to providing skillfully engineered products that improve productivity and efficiency for industrial applications worldwide. We are committed to exceeding customer expectations in every area of our business: product design, application engineering, operations and customer service.

Because of our customer focus, we are able to more thoroughly understand the needs of your business and have the resources available to work closely with you to reduce maintenance costs, eliminate redundant inventories and prevent equipment down time.

Rexnord represents the most comprehensive portfolio of power transmission and conveying components in the world with the brands you know and trust.

# The Power of Rexnord™



FLATTOP

BEARINGS

GEARED  
PRODUCTSINDUSTRIAL  
CHAIN

COUPLINGS

AEROSPACE

SPECIAL  
COMPONENTS

## WORLDWIDE CUSTOMER SERVICE

### AUSTRALIA

Rexnord Australia Pty. Ltd.  
Picton, New South Wales  
Phone: 61.2.4677.3811  
Fax: 61.2.4677.3812

### BRAZIL

Rexnord Correntes Ltda.  
Sao Leopoldo - RS  
Phone: 55.51.579.8022  
Fax: 55.51.579.8029

### CANADA

Rexnord Canada Ltd.  
Scarborough, Ontario  
Phone: 1.416.297.6868  
Fax: 1.416.297.6873

### CHINA

Rexnord China  
Shanghai, China  
Phone: 86.21.62701942  
Fax: 86.21.62701943

### EUROPE

Rexnord NV/SA  
Vilvoorde, Belgium  
Phone: 32.70.223366  
Fax: 32.2.7201023

Rexnord Kette GmbH  
Betzdorf, Germany  
Phone: 49.2741.2840  
Fax: 49.2741.284.385

### LATIN AMERICA

Rexnord International, Inc.  
Milwaukee, Wisconsin  
Phone: 1.414.643.3000  
Fax: 1.414.643.3222

### MEXICO

Rexnord S.A. de C.V.  
Queretaro, Qro.  
Phone: 52.442.218.5000  
Fax: 52.442.218.1090

### SINGAPORE

Rexnord International, Inc.  
Singapore City, Singapore  
Phone: 65.6338.5622  
Fax: 65.6338.5422

### UNITED STATES

Eastern Service Center  
Atlanta, Georgia  
Phone: 1.770.431.7200  
Fax: 1.770.431.7299

Central Service Center  
Grove City, Ohio  
Phone: 1.614.675.1800  
Fax: 1.614.675.1898

Southern Service Center  
Arlington, Texas  
Phone: 1.817.385.2800  
Fax: 1.817.385.2873



Rexnord Bearing Group  
7601 Rockville Road  
Indianapolis, Indiana 46214  
Phone: 1.317.273.5500 Fax: 1.317.273.5620  
Visit us on-line at [www.rexnord.com](http://www.rexnord.com)