

Die Set Components – INCH –



Please Order From:
Clark & Osborne, LLP
6617 Ferguson Avenue
Indianapolis, IN 46220

317-255-5668 Phone
317-253-4486 FAX
sales@clarkandosborne.com

LEMPICO[®] CO

**SERVICING
INDUSTRY
SINCE 1918**



Die Set Components – INCH

The Industry Standard, Conformed to Your Needs

LEMPCO customization services will go to virtually any length to satisfy your needs. Now, the full range of answers to your requirements is at your command. It could be a simple modification or something quite exotic. Whatever your need, **LEMPCO** will work closely with you to make sure your specs are met.

The pride we have in our ability to perform (and to provide you with profitable production performance) is stamped on every part we make. The **LEMPCO** stamp means satisfaction in terms of quality, dependability and service since 1918. Other brands may appear the same; for a system to truly perform, look for the **LEMPCO** name.



We pledge that all of our products – innovative or conventional – will be manufactured to the same high quality level throughout the coming years.

Included in our full line offering are both inch and metric size die sets and die components that are designed to numerous die standards including ISO, NAAMS and JIS. The complete product offering includes:



- Ball bearing and plain bearing die sets (including custom and catalog sets)
- Ball bearing components (including the exclusive Rotainer®)
- Plain bearing components
- Aluminum precision die sets
- Forming Machine die sets
- Lempcoshank® kits for die sets
- Ground and machined plates
- ISO and JIS Die Springs
- Nitrogen gas springs
- Formathane® Urethane springs, strippers, sheets, bars, rods and die cover film
- Accu-Bend™ Rotary Benders
- Lempcoloy® self-lubricating bushings



| | PAGE NUMBER |
|--|-------------|
| Introduction | 2 |
| Operating Conditions | 3 |
| Ball Bearing Components | |
| Rotainers® | 4 |
| Retainers | 5 |
| Demountable Steel Guide Post Bushings | 6 |
| Shoulder Guide Post Bushings | 8 |
| Press Fit Steel Sleeve Bushings | 10 |
| Straight Guide Posts | 11 |
| Flanged Demountable Guide Posts | 12 |
| Shoulder Guide Posts | 14 |
| Ball Bearing Engineering Data | 15 |
| Installation and Assembly Instructions | 16 |
| General Die Set Design Procedures | 17 |
| Plain Bearing Components | |
| Lempcoloy® Self-Lubricating Bushings | 18 |
| Precision Demountable Bushings | 20 |
| Precision Bronze-Plated Demountable Bushings | 22 |
| Precision Press Fit Bushings | 23 |
| Shoulder Guide Post Bushings | 24 |
| Flanged Demountable Guide Posts | 26 |
| Shoulder Guide Posts | 28 |
| Straight Guide Posts | 29 |
| Plain Bearing Engineering Data | |
| Boring Procedures and Dimensions | 30 |

INTRODUCTION

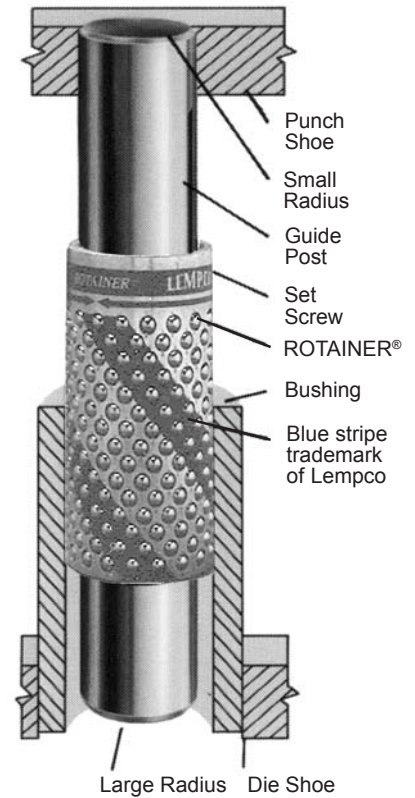

LEMPCO customization services will go to virtually any length to satisfy your guidance system needs – any diameter; any material, hardness, or finish; in any component or configuration – anything!

You have a process or problem that standard guidance system solutions can't handle. That's where **LEMPCO** guidance systems come in.



Typical Lemppo customized guidance system components.

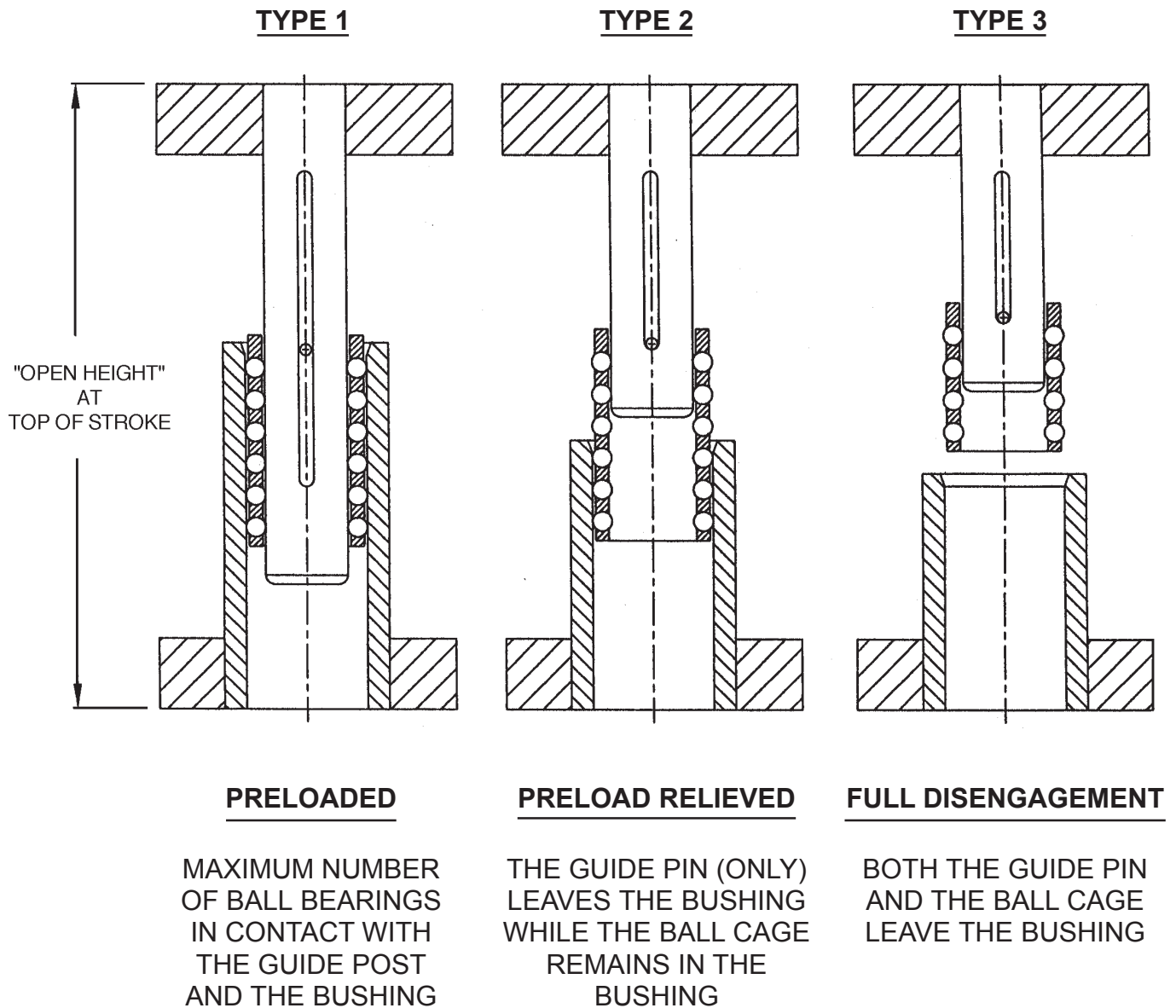

BALL BEARING ASSEMBLY LUBRICATION RECOMMENDATION

IN OPERATION OF BALL ASSEMBLY, ADD LUBRICANT ONCE EACH 8-HOUR SHIFT BY SPRAY OR BRUSH APPLICATION.

USE A LIGHTWEIGHT SPINDLE OIL OR AUTOMOTIVE TYPE AUTOMATIC TRANSMISSION FLUID.

CAUTION: NEVER USE GREASE!

For Ball Bearing Applications

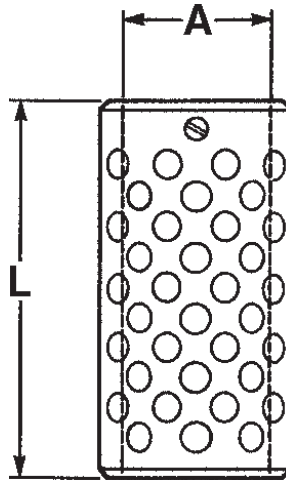
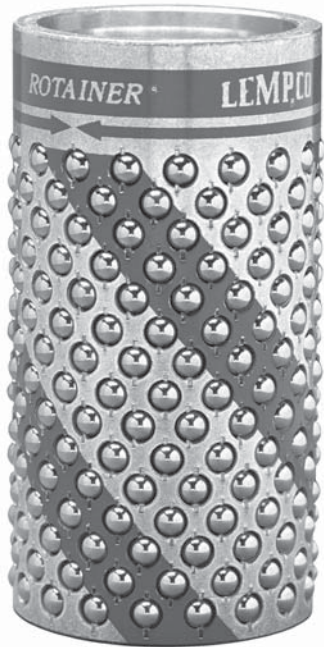

Designed to rotate on the post, as well as maintain its vertical motion, **LEMPCO's** ROTAINER® was developed to greatly reduce the amount of tracking. The disengagement of the guide post from the bushing by 1/4" at the top of the stroke will allow the ROTAINER® to rotate 360° on the guide post. The ROTAINER®, while still designed to track, (assuring a measurable amount of preload) will enable stampers to achieve high press production by reducing expensive replacement costs.

| Rotainer® Slide Replacement With Screw Assembly | | Number Of Inserts |
|---|-------------------|-------------------|
| Nom. | Assembly Part No. | |
| 3/4 | 899-9406 | 1 |
| 1 | 899-9408 | 1 |
| 1 1/4 | 899-9410 | 1 |
| 1 1/2 | 899-9412 | 1 |
| 1 3/4 | 899-9414 | 1 |
| 2 | 899-9416 | 2 |
| 2 1/2 | 899-9420 | 2 |
| 3 | 899-9424 | 2 |

NOTE: Under a preloaded condition, the ROTAINER® will only move vertically.

| Nom. Post Diameter A | Length (in) L | Catalog Number |
|--------------------------------|-------------------------|-----------------|
| 3/4" | 1 1/2 | 361-0606 |
| | 1 3/4 | 361-0607 |
| | 2 | 361-0608 |
| | 2 1/4 | 361-0609 |
| | 2 1/2 | 361-0610 |
| 1" | 1 1/2 | 361-0806 |
| | 1 3/4 | 361-0807 |
| | 2 | 361-0808 |
| | 2 1/4 | 361-0809 |
| | 2 1/2 | 361-0810 |
| 1 1/4" | 2 | 361-1008 |
| | 2 1/4 | 361-1009 |
| | 2 1/2 | 361-1010 |
| | 2 3/4 | 361-1011 |
| | 3 | 361-1012 |
| | 3 1/4 | 361-1013 |
| 1 1/2" | 2 1/2 | 361-1210 |
| | 2 3/4 | 361-1211 |
| | 3 | 361-1212 |
| | 3 1/4 | 361-1213 |
| | 3 1/2 | 361-1214 |
| | 3 3/4 | 361-1215 |
| 1 3/4" | 2 3/4 | 361-1411 |
| | 3 | 361-1412 |
| | 3 1/4 | 361-1413 |
| | 3 1/2 | 361-1414 |
| | 3 3/4 | 361-1415 |
| | 4 | 361-1416 |
| | 4 1/4 | 361-1417 |
| 2" | 3 1/4 | 361-1613 |
| | 3 1/2 | 361-1614 |
| | 3 3/4 | 361-1615 |
| | 4 | 361-1616 |
| | 4 1/4 | 361-1617 |
| | 4 1/2 | 361-1618 |
| 2 1/2" | 3 1/4 | 361-2013 |
| | 4 | 361-2016 |
| | 4 1/2 | 361-2018 |
| | 5 | 361-2020 |
| | 6 | 361-2024 |
| | 6 1/2 | 361-2026 |
| | 7 | 361-2028 |
| 3" | 5 | 361-2420 |
| | 6 | 361-2424 |
| | 7 | 361-2428 |

- Diameters and lengths not listed are available by special order.
- The LAST length for each diameter shown in the table should be used for general die set applications. Other lengths are for limited space and special applications.

For Ball Bearing Applications

| Nom. Post Diameter A | Length (in) L | Catalog Number |
|--------------------------------|-------------------------|-----------------|
| 3/4" | 1 1/2 | 931-0606 |
| | 1 3/4 | 931-0607 |
| | 2 | 931-0608 |
| | 2 1/4 | 931-0609 |
| | 2 1/2 | 931-0610 |
| 1" | 1 1/2 | 931-0806 |
| | 1 3/4 | 931-0807 |
| | 2 | 931-0808 |
| | 2 1/4 | 931-0809 |
| | 2 1/2 | 931-0810 |
| 1 1/4" | 2 | 931-1008 |
| | 2 1/4 | 931-1009 |
| | 2 1/2 | 931-1010 |
| | 2 3/4 | 931-1011 |
| | 3 | 931-1012 |
| | 3 1/4 | 931-1013 |
| 1 1/2" | 2 1/2 | 931-1210 |
| | 2 3/4 | 931-1211 |
| | 3 | 931-1212 |
| | 3 1/4 | 931-1213 |
| | 3 1/2 | 931-1214 |
| | 3 3/4 | 931-1215 |
| 1 3/4" | 2 3/4 | 931-1411 |
| | 3 | 931-1412 |
| | 3 1/4 | 931-1413 |
| | 3 1/2 | 931-1414 |
| | 3 3/4 | 931-1415 |
| | 4 | 931-1416 |
| | 4 1/4 | 931-1417 |
| 2" | 3 1/4 | 931-1613 |
| | 3 1/2 | 931-1614 |
| | 3 3/4 | 931-1615 |
| | 4 | 931-1616 |
| | 4 1/4 | 931-1617 |
| | 4 1/2 | 931-1618 |
| 2 1/2" | 3 1/4 | 931-2013 |
| | 4 | 931-2016 |
| | 4 1/2 | 931-2018 |
| | 5 | 931-2020 |
| | 6 | 931-2024 |
| | 6 1/2 | 931-2026 |
| 3" | 7 | 931-2028 |
| | 5 | 931-2420 |
| | 6 | 931-2424 |
| | 7 | 931-2428 |

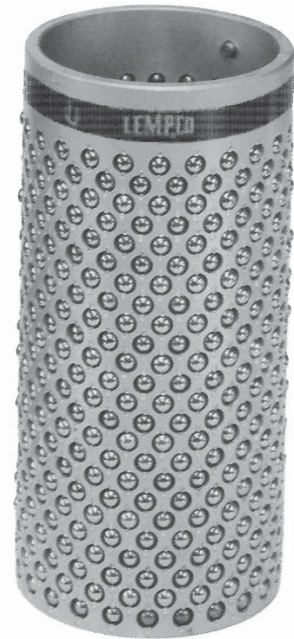
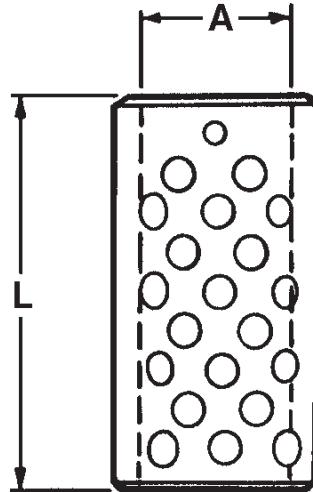

The **LEMPCO** Precision Ball Bearing Retainer possesses resistance to normal wear and to lateral motion, is smooth in high speed operation and offers precise die register. It is keyed to the guide post slot with a set screw.

- The LAST length for each diameter shown in the table should be used for general die set applications. Other lengths are for limited space and special applications.

DEMOUNTABLE STEEL GUIDE POST BUSHINGS



For Ball Bearing Applications



LEMPCO Demountable Guide Post Bushings are manufactured from 52100 tool steel and precision machined. See pages 15–17 for mounting instructions. Diameters and lengths not listed are available by special order.

| Nom. Post | B | C | E | F | Radius | | L | Catalog |
|-----------|--------|---------|-------|-------|--------|-------|-------|----------|
| | | | | | M | N | | |
| 1 | 1.7154 | 2 | 1 | 7/8 | 1.219 | 1.594 | 2 | 962-0808 |
| | | | | 1 1/8 | | | 2 1/4 | 962-0809 |
| | | | | 1 3/8 | | | 2 1/2 | 962-0810 |
| | | | | 1 5/8 | | | 2 3/4 | 962-0811 |
| | | | | 1 7/8 | | | 3 | 962-0812 |
| | | | | 2 1/8 | | | 3 1/4 | 962-0813 |
| | | | | 2 3/8 | | | 3 1/2 | 962-0814 |
| | | | | 2 5/8 | | | 3 3/4 | 962-0815 |
| 1 1/4 | 2.1054 | 2 3/8 | 1 | 1 3/8 | 1.442 | 1.864 | 2 1/2 | 962-1010 |
| | | | | 1 5/8 | | | 2 3/4 | 962-1011 |
| | | | | 1 7/8 | | | 3 | 962-1012 |
| | | | | 2 1/8 | | | 3 1/4 | 962-1013 |
| | | | | 2 3/8 | | | 3 1/2 | 962-1014 |
| | | | | 2 5/8 | | | 3 3/4 | 962-1015 |
| | | | | 2 7/8 | | | 4 | 962-1016 |
| | | | | 3 1/8 | | | 4 1/4 | 962-1017 |
| | | | | 3 3/8 | | | 4 1/2 | 962-1018 |
| | | | | 3 7/8 | | | 5 | 962-1020 |
| | | | | 4 3/8 | | | 5 1/2 | 962-1022 |
| | | | | 4 7/8 | | | 6 | 962-1024 |
| 1 1/2 | 2.4354 | 2 11/16 | 1 1/4 | 1 5/8 | 1.598 | 2.020 | 3 | 962-1212 |
| | | | | 1 7/8 | | | 3 1/4 | 962-1213 |
| | | | | 2 1/8 | | | 3 1/2 | 962-1214 |
| | | | | 2 3/8 | | | 3 3/4 | 962-1215 |
| | | | | 2 5/8 | | | 4 | 962-1216 |
| | | | | 2 7/8 | | | 4 1/4 | 962-1217 |
| | | | | 3 1/8 | | | 4 1/2 | 962-1218 |
| | | | | 3 3/8 | | | 4 3/4 | 962-1219 |
| | | | | 3 5/8 | | | 5 | 962-1220 |
| | | | | 3 7/8 | | | 5 1/4 | 962-1221 |
| | | | | 4 1/8 | | | 5 1/2 | 962-1222 |
| | | | | 4 5/8 | | | 6 | 962-1224 |
| 1 3/4 | 2.7454 | 3 | 1 1/4 | 1 5/8 | 1.754 | 2.176 | 3 | 962-1412 |
| | | | | 2 1/8 | | | 3 1/2 | 962-1414 |
| | | | | 2 3/8 | | | 3 3/4 | 962-1415 |
| | | | | 2 5/8 | | | 4 | 962-1416 |



DEMOUNTABLE STEEL GUIDE POST BUSHINGS

For Ball Bearing Applications

| Nom. Post | B | C | E | F | Radius | | L | Catalog Numbers |
|------------------|------------------|-------------------|------------------|------------------|--------|-------|------------------|-----------------|
| | | | | | M | N | | |
| 1 ^{3/4} | 2.7454 | 3 | 1 ^{1/4} | 2 ^{7/8} | 1.754 | 2.176 | 4 ^{1/4} | 962-1417 |
| | | | | 3 ^{1/8} | | | 4 ^{1/2} | 962-1418 |
| | | | | 3 ^{3/8} | | | 4 ^{3/4} | 962-1419 |
| | | | | 3 ^{5/8} | | | 5 | 962-1420 |
| | | | | 3 ^{7/8} | | | 5 ^{1/4} | 962-1421 |
| | | | | 4 ^{1/8} | | | 5 ^{1/2} | 962-1422 |
| | | | | 4 ^{5/8} | | | 6 | 962-1424 |
| | | | | 5 ^{1/8} | | | 6 ^{1/2} | 962-1426 |
| | | | | 5 ^{5/8} | | | 7 | 962-1428 |
| 2 | 3.1604 | 3 ^{9/16} | 1 ^{1/4} | 6 ^{1/8} | 2.035 | 2.457 | 7 ^{1/2} | 962-1430 |
| | | | | 1 ^{5/8} | | | 3 | 962-1612 |
| | | | | 2 ^{1/8} | | | 3 ^{1/2} | 962-1614 |
| | | | | 2 ^{3/8} | | | 3 ^{3/4} | 962-1615 |
| | | | | 2 ^{5/8} | | | 4 | 962-1616 |
| | | | | 2 ^{7/8} | | | 4 ^{1/4} | 962-1617 |
| | | | | 3 ^{1/8} | | | 4 ^{1/2} | 962-1618 |
| | | | | 3 ^{3/8} | | | 4 ^{3/4} | 962-1619 |
| | | | | 3 ^{5/8} | | | 5 | 962-1620 |
| | | | | 3 ^{7/8} | | | 5 ^{1/4} | 962-1621 |
| | | | | 4 ^{1/8} | | | 5 ^{1/2} | 962-1622 |
| | | | | 4 ^{5/8} | | | 6 | 962-1624 |
| | | | | 5 ^{1/8} | | | 6 ^{1/2} | 962-1626 |
| | | | | 5 ^{5/8} | | | 7 | 962-1628 |
| 6 ^{1/8} | 7 ^{1/2} | 962-1630 | | | | | | |
| 2 ^{1/2} | 3.6804 | 4 ^{1/16} | 1 ^{1/4} | 3 ^{5/8} | 2.259 | 2.681 | 5 | 962-2020 |
| | | | | 4 ^{1/8} | | | 5 ^{1/2} | 962-2022 |
| | | | | 4 ^{5/8} | | | 6 | 962-2024 |
| | | | | 5 ^{1/8} | | | 6 ^{1/2} | 962-2026 |
| | | | | 5 ^{5/8} | | | 7 | 962-2028 |
| | | | | 6 ^{1/8} | | | 7 ^{1/2} | 962-2030 |
| 3 | 4.1804 | 4 ^{9/16} | 1 ^{1/4} | 3 ^{5/8} | 2.531 | 2.953 | 5 | 962-2420 |
| | | | | 4 ^{1/8} | | | 5 ^{1/2} | 962-2422 |
| | | | | 4 ^{5/8} | | | 6 | 962-2424 |
| | | | | 5 ^{1/8} | | | 6 ^{1/2} | 962-2426 |
| | | | | 5 ^{5/8} | | | 7 | 962-2428 |
| | | | | 6 ^{1/8} | | | 7 ^{1/2} | 962-2430 |

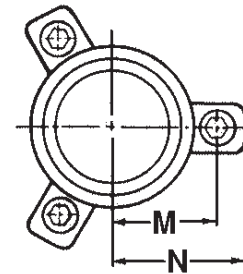
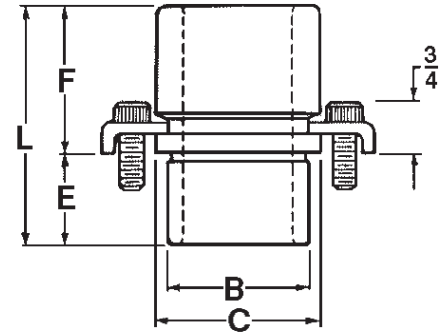

NOTE: The "C" dimension measurement is from the outside edge of the flange to the opposite outside edge.

SHOULDER GUIDE POST BUSHINGS



For Ball Bearing Applications



Shoulder Guide Post Bushings are manufactured from 52100 tool steel and precision ground. They are similar to LEMPCO's Steel Demountable Bushings but are a minimum of .008" larger on the mounting diameter, corresponding to the additional material on the Shoulder Guide Post. They may be installed either by tap or press fitting.

These bushings are interchangeable. See pages 15–17 for mounting instructions.

| Nom. Post Diameter | B | C | E | F | Radius | | L | Catalog Numbers |
|--------------------|-------|----------|-------|-------|--------|-------|-------|-----------------|
| | | | | | M | N | | |
| 1 | 1.725 | 2 | 1 | 7/8 | 1.219 | 1.594 | 2 | 963-0808 |
| | | | | 1 1/8 | | | 2 1/4 | 963-0809 |
| | | | | 1 3/8 | | | 2 1/2 | 963-0810 |
| | | | | 1 5/8 | | | 2 3/4 | 963-0811 |
| | | | | 1 7/8 | | | 3 | 963-0812 |
| | | | | 2 1/8 | | | 3 1/4 | 963-0813 |
| | | | | 2 3/8 | | | 3 1/2 | 963-0814 |
| | | | | 2 5/8 | | | 3 3/4 | 963-0815 |
| 1 1/4 | 2.115 | 2 3/8 | 1 | 1 3/8 | 1.442 | 1.864 | 2 1/2 | 963-1010 |
| | | | | 1 5/8 | | | 2 3/4 | 963-1011 |
| | | | | 1 7/8 | | | 3 | 963-1012 |
| | | | | 2 1/8 | | | 3 1/4 | 963-1013 |
| | | | | 2 3/8 | | | 3 1/2 | 963-1014 |
| | | | | 2 5/8 | | | 3 3/4 | 963-1015 |
| | | | | 2 7/8 | | | 4 | 963-1016 |
| | | | | 3 1/8 | | | 4 1/4 | 963-1017 |
| | | | | 3 3/8 | | | 4 1/2 | 963-1018 |
| | | | | 3 7/8 | | | 5 | 963-1020 |
| | | | | 4 3/8 | | | 5 1/2 | 963-1022 |
| 4 7/8 | 6 | 963-1024 | | | | | | |
| 1 1/2 | 2.445 | 2 11/16 | 1 1/4 | 1 5/8 | 1.598 | 2.020 | 3 | 963-1212 |
| | | | | 1 7/8 | | | 3 1/4 | 963-1213 |
| | | | | 2 1/8 | | | 3 1/2 | 963-1214 |
| | | | | 2 3/8 | | | 3 3/4 | 963-1215 |
| | | | | 2 5/8 | | | 4 | 963-1216 |
| | | | | 2 7/8 | | | 4 1/4 | 963-1217 |
| | | | | 3 1/8 | | | 4 1/2 | 963-1218 |
| | | | | 3 3/8 | | | 4 3/4 | 963-1219 |
| | | | | 3 5/8 | | | 5 | 963-1220 |
| | | | | 3 7/8 | | | 5 1/4 | 963-1221 |
| | | | | 4 1/8 | | | 5 1/2 | 963-1222 |
| 4 5/8 | 6 | 963-1224 | | | | | | |

NOTE: The 963 Series product line is not stocked, but is available as a special order.



SHOULDER GUIDE POST BUSHINGS

For Ball Bearing Applications

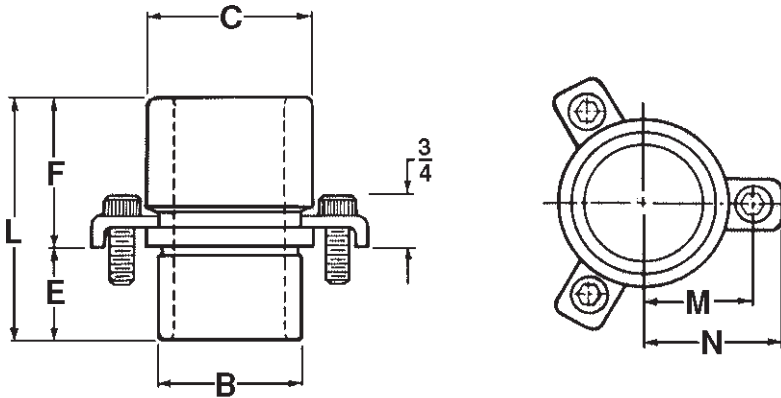

| Nom. Post Diameter | B | C | E | F | Radius | | L | Catalog Numbers | |
|--------------------|-------|-------------------|------------------|------------------|--------|-------|------------------|------------------|----------|
| | | | | | M | N | | | |
| 1 ^{3/4} | 2.755 | 3 | 1 ^{1/4} | 1 ^{5/8} | 1.754 | 2.176 | 3 | 963-1412 | |
| | | | | 2 ^{1/8} | | | 3 ^{1/2} | 963-1414 | |
| | | | | 2 ^{3/8} | | | 3 ^{3/4} | 963-1415 | |
| | | | | 2 ^{5/8} | | | 4 | 963-1416 | |
| | | | | 2 ^{7/8} | | | 4 ^{1/4} | 963-1417 | |
| | | | | 3 ^{1/8} | | | 4 ^{1/2} | 963-1418 | |
| | | | | 3 ^{3/8} | | | 4 ^{3/4} | 963-1419 | |
| | | | | 3 ^{5/8} | | | 4 clamps | 5 | 963-1420 |
| | | | | 3 ^{7/8} | | | Part No. | 5 ^{1/4} | 963-1421 |
| | | | | 4 ^{1/8} | | | 899-9125 | 5 ^{1/2} | 963-1422 |
| | | | | 4 ^{5/8} | | | | 6 | 963-1424 |
| | | | | 5 ^{1/8} | | | | 6 ^{1/2} | 963-1426 |
| | | | | 5 ^{5/8} | | | | 7 | 963-1428 |
| 6 ^{1/8} | | 7 ^{1/2} | 963-1430 | | | | | | |
| 2 | 3.170 | 3 ^{9/16} | 1 ^{1/4} | 1 ^{5/8} | 2.035 | 2.457 | 3 | 963-1612 | |
| | | | | 2 ^{1/8} | | | 3 ^{1/2} | 963-1614 | |
| | | | | 2 ^{3/8} | | | 3 ^{3/4} | 963-1615 | |
| | | | | 2 ^{5/8} | | | 4 | 963-1616 | |
| | | | | 2 ^{7/8} | | | 4 ^{1/4} | 963-1617 | |
| | | | | 3 ^{1/8} | | | 4 ^{1/2} | 963-1618 | |
| | | | | 3 ^{3/8} | | | 4 ^{3/4} | 963-1619 | |
| | | | | 3 ^{5/8} | | | 4 clamps | 5 | 963-1620 |
| | | | | 3 ^{7/8} | | | Part No. | 5 ^{1/4} | 963-1621 |
| | | | | 4 ^{1/8} | | | 899-9125 | 5 ^{1/2} | 963-1622 |
| | | | | 4 ^{5/8} | | | | 6 | 963-1624 |
| | | | | 5 ^{1/8} | | | | 6 ^{1/2} | 963-1626 |
| | | | | 5 ^{5/8} | | | | 7 | 963-1628 |
| 6 ^{1/8} | | 7 ^{1/2} | 963-1630 | | | | | | |
| 2 ^{1/2} | 3.690 | 4 ^{1/16} | 1 ^{1/4} | 3 ^{5/8} | 2.259 | 2.681 | 5 | 963-2020 | |
| | | | | 4 ^{1/8} | | | 5 ^{1/2} | 963-2022 | |
| | | | | 4 ^{5/8} | | | 6 | 963-2024 | |
| | | | | 5 ^{1/8} | | | 6 ^{1/2} | 963-2026 | |
| | | | | 5 ^{5/8} | | | 7 | 963-2028 | |
| | | | | 6 ^{1/8} | | | 7 ^{1/2} | 963-2030 | |

PRESS FIT STEEL SLEEVE BUSHINGS



For Ball Bearing Applications

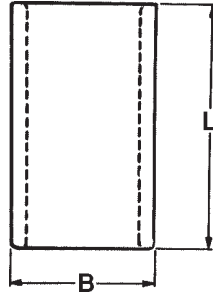

LEMPCO's Press Fit Steel Sleeve Bushings are manufactured from 52100 tool steel and precision machined. The I.D. is ground and honed to a super-fine finish to minimize resistance to free action of the retainer/Rotainer® bearings.

See pages 15–17 of this catalog for mounting instructions.

| Nom. Post Diameter | B | L | Catalog Numbers |
|--------------------|----------|-------|-----------------|
| 3/4 | 1.387 | 1 3/4 | 961-0607 |
| | | 2 | 961-0608 |
| | | 2 1/4 | 961-0609 |
| | | 2 1/2 | 961-0610 |
| | | 2 3/4 | 961-0611 |
| | | 3 | 961-0612 |
| | | 3 1/4 | 961-0613 |
| | | 3 1/2 | 961-0614 |
| | | 3 3/4 | 961-0615 |
| | | 4 | 961-0616 |
| | | 4 1/2 | 961-0618 |
| | | 5 | 961-0620 |
| 6 | 961-0624 | | |
| 1 | 1.717 | 2 | 961-0808 |
| | | 2 1/4 | 961-0809 |
| | | 2 1/2 | 961-0810 |
| | | 2 3/4 | 961-0811 |
| | | 3 | 961-0812 |
| | | 3 1/4 | 961-0813 |
| | | 3 1/2 | 961-0814 |
| | | 3 3/4 | 961-0815 |
| | | 4 | 961-0816 |
| | | 4 1/4 | 961-0817 |
| | | 4 1/2 | 961-0818 |
| | | 4 3/4 | 961-0819 |
| 5 | 961-0820 | | |
| 5 1/2 | 961-0822 | | |
| 6 | 961-0824 | | |
| 6 1/2 | 961-0826 | | |
| 7 | 961-0828 | | |
| 1 1/4 | 2.107 | 2 1/2 | 961-1010 |
| | | 2 3/4 | 961-1011 |
| | | 3 | 961-1012 |
| | | 3 1/4 | 961-1013 |
| | | 3 1/2 | 961-1014 |
| | | 3 3/4 | 961-1015 |
| | | 4 | 961-1016 |
| | | 4 1/4 | 961-1017 |
| | | 4 1/2 | 961-1018 |
| | | 5 | 961-1020 |
| | | 5 1/2 | 961-1022 |
| | | 6 | 961-1024 |
| 6 1/2 | 961-1026 | | |
| 7 | 961-1028 | | |
| 8 | 961-1032 | | |
| 9 | 961-1036 | | |

| Nom. Post Diameter | B | L | Catalog Numbers |
|--------------------|----------|-------|-----------------|
| 1 1/2 | 2.437 | 3 | 961-1212 |
| | | 3 1/4 | 961-1213 |
| | | 3 1/2 | 961-1214 |
| | | 3 3/4 | 961-1215 |
| | | 4 | 961-1216 |
| | | 4 1/4 | 961-1217 |
| | | 4 1/2 | 961-1218 |
| | | 4 3/4 | 961-1219 |
| | | 5 | 961-1220 |
| | | 5 1/4 | 961-1221 |
| | | 5 1/2 | 961-1222 |
| | | 6 | 961-1224 |
| 6 1/2 | 961-1226 | | |
| 7 | 961-1228 | | |
| 7 1/2 | 961-1230 | | |
| 8 | 961-1232 | | |
| 8 1/2 | 961-1234 | | |
| 9 | 961-1236 | | |
| 10 | 961-1240 | | |
| 11 | 961-1244 | | |
| 12 | 961-1248 | | |
| 1 3/4 | 2.747 | 3 | 961-1412 |
| | | 3 1/2 | 961-1414 |
| | | 3 3/4 | 961-1415 |
| | | 4 | 961-1416 |
| | | 4 1/4 | 961-1417 |
| | | 4 1/2 | 961-1418 |
| | | 4 3/4 | 961-1419 |
| | | 5 | 961-1420 |
| | | 5 1/4 | 961-1421 |
| | | 5 1/2 | 961-1422 |
| | | 6 | 961-1424 |
| | | 6 1/2 | 961-1426 |
| 7 | 961-1428 | | |
| 7 1/2 | 961-1430 | | |
| 8 | 961-1432 | | |
| 8 1/2 | 961-1434 | | |
| 9 | 961-1436 | | |
| 10 | 961-1440 | | |
| 11 | 961-1444 | | |
| 12 | 961-1448 | | |
| 13 | 961-1452 | | |

| Nom. Post Diameter | B | L | Catalog Numbers |
|--------------------|----------|-------|-----------------|
| 2 | 3.162 | 3 | 961-1612 |
| | | 3 1/2 | 961-1614 |
| | | 3 3/4 | 961-1615 |
| | | 4 | 961-1616 |
| | | 4 1/4 | 961-1617 |
| | | 4 1/2 | 961-1618 |
| | | 4 3/4 | 961-1619 |
| | | 5 | 961-1620 |
| | | 5 1/4 | 961-1621 |
| | | 5 1/2 | 961-1622 |
| | | 6 | 961-1624 |
| | | 6 1/2 | 961-1626 |
| | | 7 | 961-1628 |
| | | 7 1/2 | 961-1630 |
| 2 1/2 | 3.682 | 8 | 961-1632 |
| | | 8 1/2 | 961-1634 |
| | | 9 | 961-1636 |
| | | 10 | 961-1640 |
| | | 11 | 961-1644 |
| | | 12 | 961-1648 |
| | | 13 | 961-1652 |
| | | 14 | 961-1656 |
| | | 6 | 961-2024 |
| | | 6 1/2 | 961-2026 |
| | | 7 | 961-2028 |
| | | 7 1/2 | 961-2030 |
| | | 8 | 961-2032 |
| | | 8 1/2 | 961-2034 |
| 9 | 961-2036 | | |
| 9 1/2 | 961-2038 | | |
| 10 | 961-2040 | | |
| 11 | 961-2044 | | |
| 12 | 961-2048 | | |
| 13 | 961-2052 | | |
| 14 | 961-2056 | | |
| 3 | 4.182 | 6 | 961-2424 |
| | | 6 1/2 | 961-2426 |
| | | 7 | 961-2428 |
| | | 7 1/2 | 961-2430 |
| | | 8 | 961-2432 |
| | | 8 1/2 | 961-2434 |
| | | 9 | 961-2436 |
| | | 10 | 961-2440 |
| | | 11 | 961-2444 |
| | | 12 | 961-2448 |
| | | 13 | 961-2452 |
| | | 14 | 961-2456 |

For Ball Bearing Applications

LEMPCO's Straight Guide Posts for ball bearing assemblies are manufactured from 52100 tool steel and precision ground.

See pages 15–17 for mounting instructions.

| Post Diameter A | Length L | Catalog Numbers | Post Diameter A | Length L | Catalog Numbers | Post Diameter A | Length L | Catalog Numbers |
|------------------|----------|-----------------|------------------|----------|------------------|-----------------|----------|-----------------|
| 3/4 (.753) | 3 | 951-0612 | 1 1/2 (1.503) | 4 1/2 | 951-1218 | 2 (2.003) | 5 1/2 | 951-1622 |
| | 3 1/4 | 951-0613 | | 4 3/4 | 951-1219 | | 5 3/4 | 951-1623 |
| | 3 1/2 | 951-0614 | | 5 | 951-1220 | | 6 | 951-1624 |
| | 3 3/4 | 951-0615 | | 5 1/4 | 951-1221 | | 6 1/4 | 951-1625 |
| | 4 | 951-0616 | | 5 1/2 | 951-1222 | | 6 1/2 | 951-1626 |
| | 4 1/4 | 951-0617 | | 5 3/4 | 951-1223 | | 6 3/4 | 951-1627 |
| | 4 1/2 | 951-0618 | | 6 | 951-1224 | | 7 | 951-1628 |
| | 4 3/4 | 951-0619 | | 6 1/2 | 951-1226 | | 7 1/4 | 951-1629 |
| | 5 | 951-0620 | | 7 | 951-1228 | | 7 1/2 | 951-1630 |
| | 5 1/2 | 951-0622 | | 7 1/2 | 951-1230 | | 7 3/4 | 951-1631 |
| 6 | 951-0624 | 8 | | 951-1232 | 8 | | 951-1632 | |
| 1 (1.003) | 3 3/4 | 951-0815 | | 8 1/2 | 951-1234 | | 8 1/2 | 951-1634 |
| | 4 | 951-0816 | | 9 | 951-1236 | | 9 | 951-1636 |
| | 4 1/4 | 951-0817 | | 9 1/2 | 951-1238 | | 9 1/2 | 951-1638 |
| | 4 1/2 | 951-0818 | 10 | 951-1240 | 10 | | 951-1640 | |
| | 4 3/4 | 951-0819 | 10 1/2 | 951-1242 | 10 1/2 | | 951-1642 | |
| | 5 | 951-0820 | 11 | 951-1244 | 11 | | 951-1644 | |
| | 5 1/4 | 951-0821 | 11 1/2 | 951-1246 | 11 1/2 | | 951-1646 | |
| | 5 1/2 | 951-0822 | 12 | 951-1248 | 12 | 951-1648 | | |
| | 5 3/4 | 951-0823 | 12 1/2 | 951-1250 | 12 1/2 | 951-1650 | | |
| | 6 | 951-0824 | 13 | 951-1252 | 13 | 951-1652 | | |
| | 6 1/2 | 951-0826 | 14 | 951-1256 | 14 | 951-1656 | | |
| | 7 | 951-0828 | 1 3/4 (1.753) | 5 | 951-1420 | 15 | 951-1660 | |
| | 7 1/2 | 951-0830 | | 5 1/4 | 951-1421 | 16 | 951-1664 | |
| | 8 | 951-0832 | | 5 1/2 | 951-1422 | 17 | 951-1668 | |
| 8 1/2 | 951-0834 | 5 3/4 | | 951-1423 | 18 | 951-1672 | | |
| 9 | 951-0836 | 6 | | 951-1424 | 2 1/2 (2.503) | 8 | 951-2032 | |
| 10 | 951-0840 | 6 1/4 | | 951-1425 | | 8 1/2 | 951-2034 | |
| 11 | 951-0844 | 6 1/2 | | 951-1426 | | 9 | 951-2036 | |
| 12 | 951-0848 | 7 | | 951-1428 | | 10 | 951-2040 | |
| 1 1/4 (1.253) | 4 1/2 | 951-1018 | | 7 1/2 | | 951-1430 | 11 | 951-2044 |
| | 4 3/4 | 951-1019 | | 8 | | 951-1432 | 12 | 951-2048 |
| | 5 | 951-1020 | 8 1/2 | 951-1434 | | 13 | 951-2052 | |
| | 5 1/4 | 951-1021 | 9 | 951-1436 | | 14 | 951-2056 | |
| | 5 1/2 | 951-1022 | 9 1/2 | 951-1438 | 17 | 951-2068 | | |
| | 5 3/4 | 951-1023 | 10 | 951-1440 | 20 | 951-2080 | | |
| | 6 | 951-1024 | 10 1/2 | 951-1442 | 3 (3.003) | 8 | 951-2432 | |
| | 6 1/2 | 951-1026 | 11 | 951-1444 | | 8 1/2 | 951-2434 | |
| | 7 | 951-1028 | 11 1/2 | 951-1446 | | 9 | 951-2436 | |
| | 7 1/2 | 951-1030 | 12 | 951-1448 | | 10 | 951-2440 | |
| | 8 | 951-1032 | 12 1/2 | 951-1450 | | 11 | 951-2444 | |
| | 8 1/2 | 951-1034 | 13 | 951-1452 | | 12 | 951-2448 | |
| 9 | 951-1036 | 14 | 951-1456 | 13 | | 951-2452 | | |
| 10 | 951-1040 | 15 | 951-1460 | 14 | | 951-2456 | | |
| 11 | 951-1044 | 17 | 951-1468 | 17 | 951-2468 | | | |
| 12 | 951-1048 | | | 20 | 951-2480 | | | |

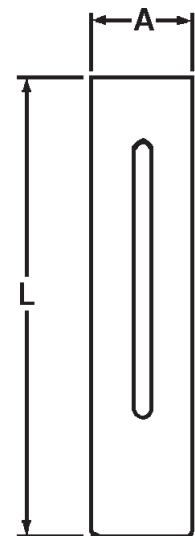

FLANGED DEMOUNTABLE GUIDE POSTS



For Ball Bearing Applications



The LEMPCO Flanged Demountable Guide Post for ball bearing assemblies is designed for those who prefer the convenience of a removable post to expedite die repairs. The post is tap fitted into the pin plate bore with the flange flush to the ground surface. See pages 15–17 for bore size data.

These Demountable Guide Posts are manufactured from 52100 tool steel.

| Diameter | | | Nominal Length | | | | Catalog Numbers | |
|--|--------------------------------|------------------|---------------------------------|-------------------------------|---------------------------------|---------------------------------|--------------------------------|----------|
| Post A | Flange B | C | E | F | Radius | | | |
| | | | | | M | N | | L |
| 1 (1.003) | 1 ⁵ / ₁₆ | 1.0009 1.0006 | 1 ³ / ₁₆ | 2 ¹ / ₂ | 1 ³ / ₁₆ | 1 ¹ / ₈ | 3 ³ / ₄ | 956-0815 |
| | | | | 2 ³ / ₄ | | | 4 | 956-0816 |
| | | | | 3 | | | 4 ¹ / ₄ | 956-0817 |
| | | | | 3 ¹ / ₄ | | | 4 ¹ / ₂ | 956-0818 |
| | | | | 3 ¹ / ₂ | | | 4 ³ / ₄ | 956-0819 |
| | | | | 3 ³ / ₄ | | | 5 | 956-0820 |
| | | | | 4 | | | 5 ¹ / ₄ | 956-0821 |
| | | | | 4 ¹ / ₄ | | | 5 ¹ / ₂ | 956-0822 |
| | | | | 4 ¹ / ₂ | | | 5 ³ / ₄ | 956-0823 |
| | | | | 4 ³ / ₄ | | | 6 | 956-0824 |
| | | | | 5 ¹ / ₄ | | | 6 ¹ / ₂ | 956-0826 |
| | | | | 5 ³ / ₄ | | | 7 | 956-0828 |
| | | | | 6 ¹ / ₄ | | | 7 ¹ / ₂ | 956-0830 |
| | | | | 6 ³ / ₄ | | | 8 | 956-0832 |
| | | | | 7 ¹ / ₄ | | | 8 ¹ / ₂ | 956-0834 |
| 7 ³ / ₄ | 9 | 956-0836 | | | | | | |
| 1 ¹ / ₄ (1.253) | 1 ⁹ / ₁₆ | 1.2509 1.2506 | 1 ³ / ₁₆ | 3 ¹ / ₄ | 6 ³ / ₆₄ | 1 ²⁵ / ₆₄ | 4 ¹ / ₂ | 956-1018 |
| | | | | 3 ¹ / ₂ | | | 4 ³ / ₄ | 956-1019 |
| | | | | 3 ³ / ₄ | | | 5 | 956-1020 |
| | | | | 4 | | | 5 ¹ / ₄ | 956-1021 |
| | | | | 4 ¹ / ₄ | | | 5 ¹ / ₂ | 956-1022 |
| | | | | 4 ¹ / ₂ | | | 5 ³ / ₄ | 956-1023 |
| | | | | 4 ³ / ₄ | | | 6 | 956-1024 |
| | | | | 5 ¹ / ₄ | | | 6 ¹ / ₂ | 956-1026 |
| | | | | 5 ³ / ₄ | | | 7 | 956-1028 |
| | | | | 6 ¹ / ₄ | | | 7 ¹ / ₂ | 956-1030 |
| | | | | 6 ³ / ₄ | | | 8 | 956-1032 |
| | | | | 7 ¹ / ₄ | | | 8 ¹ / ₂ | 956-1034 |
| 7 ³ / ₄ | 9 | 956-1036 | | | | | | |
| 8 ³ / ₄ | 10 | 956-1040 | | | | | | |
| 9 ³ / ₄ | 11 | 956-1044 | | | | | | |
| 10 ³ / ₄ | 12 | 956-1048 | | | | | | |
| 1 ¹ / ₂ (1.503) | 1 ⁷ / ₈ | 1.5009 1.5006 | 1 ⁷ / ₁₆ | 3 | 1 ¹ / ₈ | 1 ¹⁷ / ₃₂ | 4 ¹ / ₂ | 956-1218 |
| | | | | 3 ¹ / ₄ | | | 4 ³ / ₄ | 956-1219 |
| | | | | 3 ¹ / ₂ | | | 5 | 956-1220 |
| | | | | 3 ³ / ₄ | | | 5 ¹ / ₄ | 956-1221 |
| | | | | 4 | | | 5 ¹ / ₂ | 956-1222 |
| | | | | 4 ¹ / ₄ | | | 5 ³ / ₄ | 956-1223 |
| | | | | 4 ¹ / ₂ | | | 6 | 956-1224 |
| | | | | 5 | | | 6 ¹ / ₂ | 956-1226 |
| | | | | 5 ¹ / ₂ | | | 7 | 956-1228 |
| | | | | 6 | | | 7 ¹ / ₂ | 956-1230 |
| | | | | 6 ¹ / ₂ | | | 8 | 956-1232 |
| | | | | 7 | | | 8 ¹ / ₂ | 956-1234 |
| | | | | 7 ¹ / ₂ | | | 9 | 956-1236 |
| | | | | 8 | | | 9 ¹ / ₂ | 956-1238 |
| | | | | 8 ¹ / ₂ | | | 10 | 956-1240 |
| | | | | 9 | | | 10 ¹ / ₂ | 956-1242 |
| | | | | 9 ¹ / ₂ | | | 11 | 956-1244 |
| | | | | 10 | | | 11 ¹ / ₂ | 956-1246 |
| 10 ¹ / ₂ | 12 | 956-1248 | | | | | | |
| 11 | 12 ¹ / ₂ | 956-1250 | | | | | | |
| 11 ¹ / ₂ | 13 | 956-1252 | | | | | | |
| 12 ¹ / ₂ | 14 | 956-1256 | | | | | | |
| 1 ³ / ₄ (1.753) | 2 ¹ / ₄ | 1.7509 1.7506 | 1 ¹¹ / ₁₆ | 3 ¹ / ₄ | 1 ¹⁹ / ₆₄ | 1 ⁴⁵ / ₆₄ | 5 | 956-1420 |
| | | | | 3 ¹ / ₂ | | | 5 ¹ / ₄ | 956-1421 |
| | | | | 3 ³ / ₄ | | | 5 ¹ / ₂ | 956-1422 |
| | | | | 4 | | | 5 ³ / ₄ | 956-1423 |
| | | | | 4 ¹ / ₄ | | | 6 | 956-1424 |
| | | | | 4 ¹ / ₂ | | | 6 ¹ / ₄ | 956-1425 |
| 4 ³ / ₄ | 6 ¹ / ₂ | 956-1426 | | | | | | |



FLANGED DEMOUNTABLE GUIDE POSTS

For Ball Bearing Applications

| Diameter | | | Nominal Length | | | | Catalog Numbers | |
|------------------|-------------|------------------|----------------|--------------|---------|---------|-----------------|------------------|
| Post A | Flange B | C | E | F | Radius | | | |
| | | | | | M | N | | |
| 1 3/4 (1.753) | 2 1/4 | 1.7509 1.7506 | 1 11/16 | 5 1/4 | 1 19/64 | 1 45/64 | 7 | 956-1428 |
| | | | | 5 3/4 | | | 7 1/2 | 956-1430 |
| | | | | 6 1/4 | | | 8 | 956-1432 |
| | | | | 6 3/4 | | | 8 1/2 | 956-1434 |
| | | | | 7 1/4 | | | 9 | 956-1436 |
| | | | | 7 3/4 | | | 9 1/2 | 956-1438 |
| | | | | 8 1/4 | | | 10 | 956-1440 |
| | | | | 8 3/4 | | | 10 1/2 | 956-1442 |
| | | | | 9 1/4 | | | 11 | 956-1444 |
| | | | | 9 3/4 | | | 11 1/2 | 956-1446 |
| | | | | 10 1/4 | | | 12 | 956-1448 |
| | | | | 10 3/4 | | | 12 1/2 | 956-1450 |
| | | | | 11 1/4 | | | 13 | 956-1452 |
| | | | | 12 1/4 | | | 14 | 956-1456 |
| | | | | 13 1/4 | | | 15 | 956-1460 |
| | | | | 15 1/4 | | | 17 | 956-1468 |
| | | | | 2 (2.003) | | | 2 1/2 | 2.0009 2.0006 |
| 3 3/4 | 5 3/4 | 956-1623 | | | | | | |
| 4 | 6 | 956-1624 | | | | | | |
| 4 1/4 | 6 1/4 | 956-1625 | | | | | | |
| 4 1/2 | 6 1/2 | 956-1626 | | | | | | |
| 4 3/4 | 6 3/4 | 956-1627 | | | | | | |
| 5 | 7 | 956-1628 | | | | | | |
| 5 1/4 | 7 1/4 | 956-1629 | | | | | | |
| 5 1/2 | 7 1/2 | 956-1630 | | | | | | |
| 5 3/4 | 7 3/4 | 956-1631 | | | | | | |
| 6 | 8 | 956-1632 | | | | | | |
| 6 1/2 | 8 1/2 | 956-1634 | | | | | | |
| 7 | 9 | 956-1636 | | | | | | |
| 7 1/2 | 9 1/2 | 956-1638 | | | | | | |
| 8 | 10 | 956-1640 | | | | | | |
| 8 1/2 | 10 1/2 | 956-1642 | | | | | | |
| 9 | 11 | 956-1644 | | | | | | |
| 9 1/2 | 11 1/2 | 956-1646 | | | | | | |
| 10 | 12 | 956-1648 | | | | | | |
| 10 1/2 | 12 1/2 | 956-1650 | | | | | | |
| 11 | 13 | 956-1652 | | | | | | |
| 12 | 14 | 956-1656 | | | | | | |
| 13 | 15 | 956-1660 | | | | | | |
| 14 | 16 | 956-1664 | | | | | | |
| 15 | 17 | 956-1668 | | | | | | |
| 16 | 18 | 956-1672 | | | | | | |
| 2 1/2 (2.503) | 3 | 2.5009 2.5006 | 1 15/16 | 6 | 1 43/64 | 2 5/64 | 8 | 956-2032 |
| | | | | 6 1/2 | | | 8 1/2 | 956-2034 |
| | | | | 7 | | | 9 | 956-2036 |
| | | | | 8 | | | 10 | 956-2040 |
| | | | | 9 | | | 11 | 956-2044 |
| | | | | 10 | | | 12 | 956-2048 |
| | | | | 11 | | | 13 | 956-2052 |
| | | | | 12 | | | 14 | 956-2056 |
| | | | | 15 | | | 17 | 956-2068 |
| 18 | 20 | 956-2080 | | | | | | |
| 3 (3.003) | 3 1/2 | 3.0009 3.0006 | 2 7/16 | 5 1/2 | 1 59/64 | 2 21/64 | 8 | 956-2432 |
| | | | | 6 | | | 8 1/2 | 956-2434 |
| | | | | 6 1/2 | | | 9 | 956-2436 |
| | | | | 7 1/2 | | | 10 | 956-2440 |
| | | | | 8 1/2 | | | 11 | 956-2444 |
| | | | | 9 1/2 | | | 12 | 956-2448 |
| | | | | 10 1/2 | | | 13 | 956-2452 |
| | | | | 11 1/2 | | | 14 | 956-2456 |
| | | | | 14 1/2 | | | 17 | 956-2468 |
| | | | | 17 1/2 | | | 20 | 956-2480 |

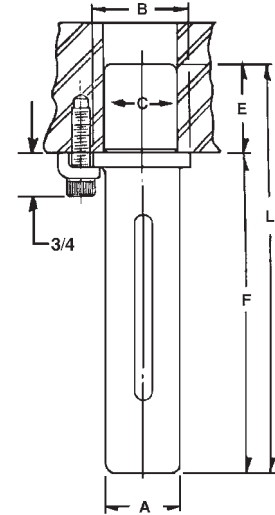

SHOULDER GUIDE POSTS



For Ball Bearing Applications

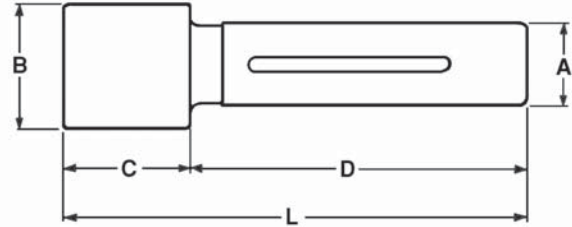

Mounting diameters of the Shoulder Guide Posts are a minimum of .008" over the sizes of Press Fit Steel Sleeve Bushings and .008" over the Demountable Steel Bushings to allow grind stock for precision fitting in new set construction and to allow reboring as necessary in replacing posts and bushings in used sets. These posts also may be used with Press Fit Sleeve Bushings and Demountable Bushings providing the through bore size accords with mounting diameters.

The Shoulder Guide Posts are manufactured from 52100 tool steel and precision ground. See pages 15–17 for mounting instructions.

NOTE: The 953 Series product line is not stocked, but is available as a special order.

| Diameter A | B | Length L | C | D | Catalog Numbers |
|------------------|-------|-------------|-------|----------|--------------------|
| 1 (1.003) | 1.725 | 4 1/2 | 1 3/8 | 3 | 953-0818 |
| | | 5 | | 3 1/2 | 953-0820 |
| | | 5 1/2 | | 4 | 953-0822 |
| | | 6 | | 4 1/2 | 953-0824 |
| | | 6 1/2 | | 5 | 953-0826 |
| | | 7 | | 5 1/2 | 953-0828 |
| | | 7 1/2 | | 6 | 953-0830 |
| | | 8 | 6 1/2 | 953-0832 | |
| 1 1/4 (1.253) | 2.115 | 5 | 1 7/8 | 3 | 953-1020 |
| | | 5 1/2 | | 3 1/2 | 953-1022 |
| | | 6 | | 4 | 953-1024 |
| | | 6 1/2 | | 4 1/2 | 953-1026 |
| | | 7 | | 5 | 953-1028 |
| | | 7 1/2 | | 5 1/2 | 953-1030 |
| | | 8 | | 6 | 953-1032 |
| | | 8 1/2 | | 6 1/2 | 953-1034 |
| | | 9 | 7 | 953-1036 | |
| 1 1/2 (1.503) | 2.445 | 7 | 2 3/8 | 4 5/8 | 953-1228 |
| | | 7 1/2 | | 5 1/8 | 953-1230 |
| | | 8 | | 5 5/8 | 953-1232 |
| | | 8 1/2 | | 6 1/8 | 953-1234 |
| | | 9 | | 6 5/8 | 953-1236 |
| | | 9 1/2 | | 7 1/8 | 953-1238 |
| | | 10 | 7 5/8 | 953-1240 | |
| 1 3/4 (1.753) | 2.755 | 7 1/2 | 2 7/8 | 4 5/8 | 953-1430 |
| | | 8 | | 5 1/8 | 953-1432 |
| | | 8 1/2 | | 5 5/8 | 953-1434 |
| | | 9 | | 6 1/8 | 953-1436 |
| | | 9 1/2 | | 6 5/8 | 953-1438 |
| | | 10 | 7 1/8 | 953-1440 | |
| 2 (2.003) | 3.170 | 8 | 3 3/8 | 4 5/8 | 953-1632 |
| | | 9 | | 5 5/8 | 953-1636 |
| | | 10 | | 6 5/8 | 953-1640 |
| | | 11 | | 7 5/8 | 953-1644 |
| | | 12 | | 8 5/8 | 953-1648 |
| | | 13 | | 9 5/8 | 953-1652 |
| 2 1/2 (2.503) | 3.690 | 9 | 3 7/8 | 5 1/8 | 953-2036 |
| | | 10 | | 6 1/8 | 953-2040 |
| | | 11 | | 7 1/8 | 953-2044 |
| | | 12 | | 8 1/8 | 953-2048 |
| | | 13 | | 9 1/8 | 953-2052 |
| | | 14 | | 10 1/8 | 953-2056 |

Boring Procedures and Dimensions

Holes for LEMPCO Ball Bearing Guide Posts and Bushings should be jig bored for best results. The punch holder and dieholder should be clamped together and bored in one setup in order to maintain dead center alignment between the upper and lower bores. If it is not possible to bore in this manner, a tolerance of $\pm .0005$ " between centers (see illustration) must be held. Bores should be smooth and free from tool marks to provide proper bearing area for the guide post and bushing.

Dieholder bores must be perpendicular to that surface of the dieholder which will back up the die. The bottom surface of the dieholder must be parallel to the die backup surface. The same holds true for the punch holder: the bores must be perpendicular to that surface which will back up the punches, and the top surface parallel to the punch backup surface.

Break the corners of the bored holes to a generous chamfer. On sets with a symmetrical profile one pin and bushing should be offset to prevent accidental reversing of the punch holder during assembly.

All LEMPCO Ball Bearing Guide Posts, Bushings Retainers and Rotainers are completely interchangeable without any necessity whatsoever for select fitting of any kind, and if mounted in accordance with boring and assembly instructions given on this and the following page do not require any grinding, honing, lapping, or any other modifications of any kind. Please note the dimensions given in the following table. Our experience over many years proves that these are optimum dimensions. Variations must be avoided.

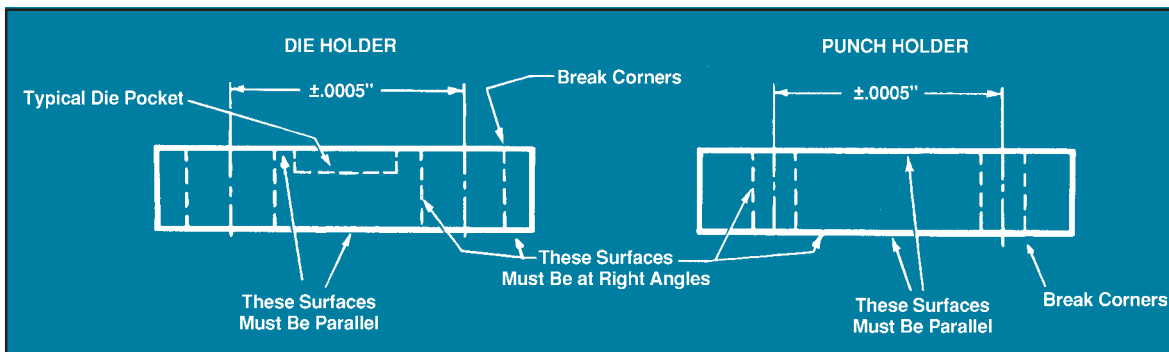

BORE CHART BALL BEARING COMPONENTS (INCH)

| Nominal Guide Post Diameter | #951-SERIES STRAIGHT GUIDE PIN | #956-SERIES DEMOUNTABLE GUIDE PIN | #953-SERIES SHOULDER GUIDE PIN | #961-SERIES STRAIGHT SLEEVE BUSHING | #962-SERIES STRAIGHT SLEEVE BUSHING |
|-----------------------------|---|---|--|---|---|
| | (PRESS FIT) | (TAP FIT) | (PRESS FIT) | (PRESS FIT) | (TAP FIT) |
| | BORE SIZE | BORE SIZE | BORE SIZE | BORE SIZE | BORE SIZE |
| 3/4" | .7513 $\begin{smallmatrix} +.000 \\ -.001 \end{smallmatrix}$ | N/A | N/A | 1.3858 $\begin{smallmatrix} +.000 \\ -.001 \end{smallmatrix}$ | N/A |
| 1" | 1.0013 $\begin{smallmatrix} +.000 \\ -.001 \end{smallmatrix}$ | 1.0013 $\begin{smallmatrix} +.0000 \\ -.0005 \end{smallmatrix}$ | BORE HOLE .0009" TO .0019" SMALLER THAN SHOULDER DIAMETER OF GUIDE | 1.7158 $\begin{smallmatrix} +.000 \\ -.001 \end{smallmatrix}$ | 1.7158 $\begin{smallmatrix} +.0000 \\ -.0005 \end{smallmatrix}$ |
| 1 1/4" | 1.2513 $\begin{smallmatrix} +.000 \\ -.001 \end{smallmatrix}$ | 1.2513 $\begin{smallmatrix} +.0000 \\ -.0005 \end{smallmatrix}$ | | 2.1058 $\begin{smallmatrix} +.000 \\ -.001 \end{smallmatrix}$ | 2.1058 $\begin{smallmatrix} +.0000 \\ -.0005 \end{smallmatrix}$ |
| 1 1/2" | 1.5013 $\begin{smallmatrix} +.000 \\ -.001 \end{smallmatrix}$ | 1.5013 $\begin{smallmatrix} +.0000 \\ -.0005 \end{smallmatrix}$ | | 2.4358 $\begin{smallmatrix} +.000 \\ -.001 \end{smallmatrix}$ | 2.4358 $\begin{smallmatrix} +.0000 \\ -.0005 \end{smallmatrix}$ |
| 1 3/4" | 1.7513 $\begin{smallmatrix} +.000 \\ -.001 \end{smallmatrix}$ | 1.7513 $\begin{smallmatrix} +.0000 \\ -.0005 \end{smallmatrix}$ | | 2.7458 $\begin{smallmatrix} +.000 \\ -.001 \end{smallmatrix}$ | 2.7458 $\begin{smallmatrix} +.0000 \\ -.0005 \end{smallmatrix}$ |
| 2" | 2.0013 $\begin{smallmatrix} +.000 \\ -.001 \end{smallmatrix}$ | 2.0013 $\begin{smallmatrix} +.0000 \\ -.0005 \end{smallmatrix}$ | | 3.1608 $\begin{smallmatrix} +.000 \\ -.001 \end{smallmatrix}$ | 3.1608 $\begin{smallmatrix} +.0000 \\ -.0005 \end{smallmatrix}$ |
| 2 1/2" | 2.5013 $\begin{smallmatrix} +.000 \\ -.001 \end{smallmatrix}$ | 2.5013 $\begin{smallmatrix} +.0000 \\ -.0005 \end{smallmatrix}$ | | 3.6808 $\begin{smallmatrix} +.000 \\ -.001 \end{smallmatrix}$ | 3.6808 $\begin{smallmatrix} +.0000 \\ -.0005 \end{smallmatrix}$ |
| 3" | 3.0013 $\begin{smallmatrix} +.000 \\ -.001 \end{smallmatrix}$ | 3.0013 $\begin{smallmatrix} +.0000 \\ -.0005 \end{smallmatrix}$ | N/A | 4.1808 $\begin{smallmatrix} +.000 \\ -.001 \end{smallmatrix}$ | 4.1808 $\begin{smallmatrix} +.0000 \\ -.0005 \end{smallmatrix}$ |

BALL BEARING ENGINEERING DATA



Installation and Assembly Instructions

In order to maintain the die and punch alignment, it is essential that the guide posts and bushings be at absolute right angles with the punch and die backup surfaces.

FIGURE 1 represents a typical guide post and ROTAINER®. Please note that the end of the guide post with the *small* radius is press fit into the punch shoe, and that the ROTAINER® is assembled with the ROTAINER® slide assembly toward the same end of the guide post. On the bushing, however, the end with the *large* outside diameter radius is press fit into the die shoe.

NOTE: LEMPCO Demountable Bushings and Flanged Demountable Guide Posts are tap fitted. Bores should be to specifications, and both bushings and guide posts should be seated flush to ground surface of support shoe and held securely by clamps and cap screws. These bushings and guide posts are removable; on installation the die will register accurately.

Check the squareness of the guide post or bushing with a precision square. Tap the sides slightly with a soft hammer until the guide post or bushing is perpendicular.

Press fit about $\frac{1}{4}$ " and check with the precision square again, tapping the sides with a soft hammer as necessary, to ensure squareness. A bronze, babbitt or fiber hammer is recommended.

NOTE: With Demountable Boss Bushings, be sure to press against the hardened liner and not against the casting.

Press fit by small increments (not over $\frac{1}{2}$ " each) checking with the precision square after each press. Do not allow guide post or bushing to protrude through the lower side of the plate. It is advisable to place a $\frac{1}{64}$ " shim under the guide post or bushing as a stop.

For Demountable Boss Bushings and Demountable Bushings, after the bushing is tap fit to the shoulder, the shoe may be drilled with the bushing in place. Tighten screws gradually, moving from one to another until all are tight.

After complete assembly of the bushings, check the ID top and bottom for taper. Should taper be found, hone the ID until original size is obtained.

Note: This should not be necessary if boring instructions were strictly adhered to.

Assemble ROTAINER® to guide post (FIGURE 1) by screwing the set screw in until flush with special ROTAINER® slide. Vertical and rotational movement should now be tested to insure freedom of movement. After testing is completed, stake set screw. Lubricate only with a light spindle oil.

Note: The only tool necessary to assemble the ROTAINER® is a screw driver.

Assemble punch and die holder. Be sure to allow ROTAINERS® to hang free (see FIGURE 2) supported by the special ROTAINER® slide when assembling die set. Work the punch holder up and down a few times to assure there is no binding.

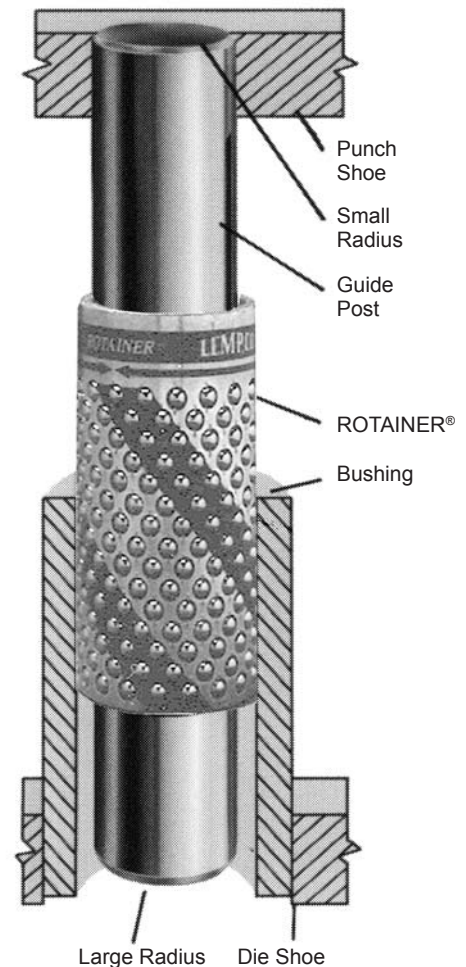

FIGURE 1

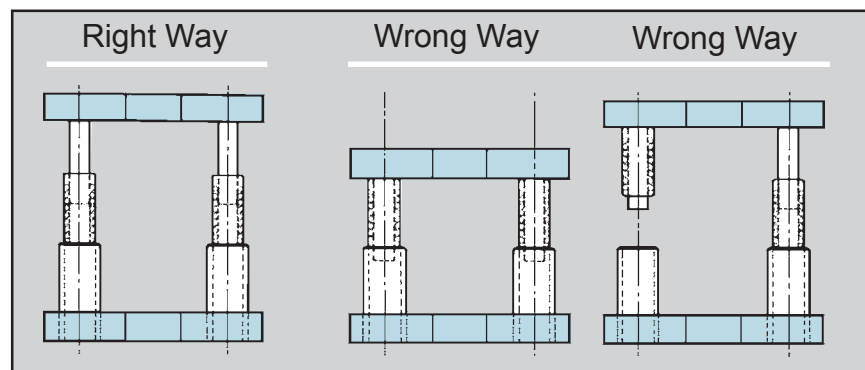
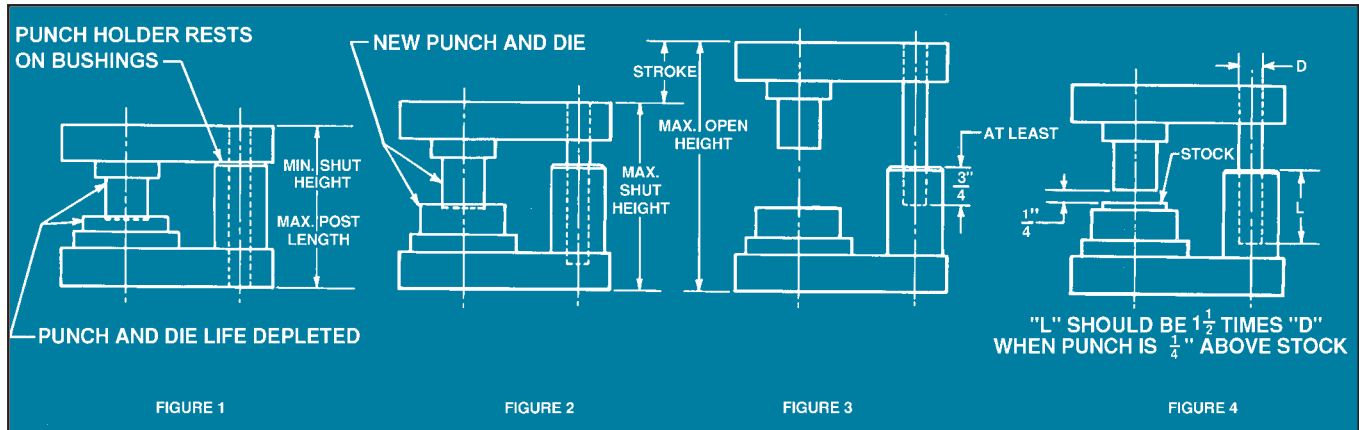

FIGURE 2

General Die Set Design Procedures

SPECIFICATIONS:

1. Maximum Shut Height – See Figure 2, below.
2. Minimum Shut Height – See Figure 1.
3. Stroke – See Figures 2 and 3.
4. Maximum Open Height – See Figures 2 and 3.



- A. Lay out die as in Figure 1 (Minimum Shut Height). This determines maximum guide post length and maximum bushing height.
- B. Lay out die as in Figure 2 (Maximum Shut Height).
- C. Maximum Open Height (Maximum Shut Height plus Stroke) as in Figure 3 shows minimum guide post engagement in bushing that is required. If this is at least $\frac{3}{4}$ " then conditions are ideal. However, if this dimension is less than $\frac{3}{4}$ " then Figure 4 should be considered. Actual work is done for only a fraction of the total stroke on most dies and if conditions shown in Figure 4 are satisfied in conjunction with Figure 1 and Figure 2, then full length of stroke and maximum open height can be disregarded.

ALSO NOTE, HOWEVER, THAT LONGER THAN NORMAL STROKES MAY BE UTILIZED BY DISENGAGING GUIDE POST AND, IF ABSOLUTELY NECESSARY, THE ROTAINER® FROM THE BUSHING ON THE UPWARD TRAVEL PROVIDED: 1 – THE OPERATION IS VERTICAL, 2 – THE OPERATION IS NOT FASTER THAN 150 STROKES PER MINUTE, AND 3 – THE INSIDE DIAMETER OF THE BUSHING IS BELL MOUTHED MINIMUM $\frac{1}{4}$ ".

ON INCLINED OPERATIONS, OR AT SPEEDS IN EXCESS OF 150 STROKES PER MINUTE, THE GUIDE POST MUST ENGAGE THE BUSHING AT ALL TIMES AT LEAST $\frac{3}{4}$ " (THE ROTAINER® MUST BE ENGAGED BY THE GUIDE POST AND BUSHINGS AT ALL TIMES).

LEMPCOLOY® SELF-LUBRICATING BUSHINGS

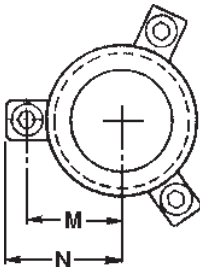
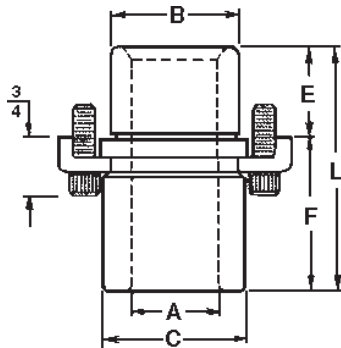
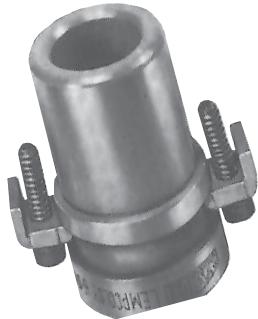

Lempcoloy® is now available in standard and short shoulder demountable bushings for use in die set applications. This unique bearing material has a hardness rating of 60-70 on the Rockwell C scale, and offers exceptional wear resistance in addition to being self-lubricating.

Although a light spindle oil is recommended at start-up, **Lempcoloy®** can be used with absolutely no lubrication in demanding applications. The medical and food processing industries have used **Lempcoloy®** for decades with exceptionally good results.

Ten sizes of bushings are available, in both the standard and short shoulder designs, with a range of the inside diameter from .5 inches to 3 inches.

The **Lempcoloy®** demountable bushings work well with 501 and 506 style plain bearing posts. Additionally, custom bushings may be ordered in sizes from a .5 inch to a 7 inch inside diameter with lengths up to 14 inches.



LEMPCO[®] SELF-LUBRICATING BUSHINGS

Shoulder - Lempcoloy[®]

| Catalog Number | Inside Dia. A | | B | C | E | F | L | Radius | |
|----------------|---------------|-------|-------|---------|---------|-------|---------|---------|---------|
| | Nom. | Dec. | | | | | | M | N |
| 608-0409 | 1/2 | .502 | .812 | 15/16 | 5/8 | 1 1/2 | 2 1/8 | .697 | 1.010 |
| 608-0509 | 5/8 | .627 | 1.000 | 1 3/16 | 5/8 | 1 1/2 | 2 1/8 | 13/16 | 1 1/8 |
| 608-0611 | 3/4 | .752 | 1.125 | 1 5/16 | 7/8 | 1 3/4 | 2 5/8 | 7/8 | 1 3/16 |
| 608-0811 | 1 | 1.002 | 1.500 | 1 11/16 | 7/8 | 1 3/4 | 2 5/8 | 1 1/16 | 1 3/8 |
| 608-1013 | 1 1/4 | 1.252 | 1.750 | 1 15/16 | 1 1/8 | 2 | 3 1/8 | 1 7/32 | 1 17/32 |
| 608-1214 | 1 1/2 | 1.502 | 2.000 | 2 3/16 | 1 3/8 | 2 | 3 3/8 | 1 11/32 | 1 21/32 |
| 608-1414 | 1 3/4 | 1.752 | 2.250 | 2 1/2 | 1 3/8 | 2 | 3 3/8 | 1 1/2 | 1 13/16 |
| 608-1616 | 2 | 2.002 | 2.500 | 2 7/8 | 1 13/16 | 2 | 3 13/16 | 1 45/64 | 2 1/64 |
| 608-2018 | 2 1/2 | 2.502 | 3.250 | 3 5/8 | 1 13/16 | 2 1/2 | 4 5/16 | 2 5/64 | 2 25/64 |
| 608-2418 | 3 | 3.002 | 3.750 | 4 1/8 | 1 13/16 | 2 1/2 | 4 5/16 | 2 11/32 | 2 21/32 |

Short Shoulder - Lempcoloy[®]

| Catalog Number | Inside Dia. A | | B | C | E | F | L | Radius | |
|----------------|---------------|-------|-------|---------|---------|-------|---------|---------|---------|
| | Nom. | Dec. | | | | | | M | N |
| 607-0406 | 1/2 | .502 | .812 | 15/16 | 5/8 | 13/16 | 1 7/16 | .697 | 1.010 |
| 607-0506 | 5/8 | .627 | 1.000 | 1 3/16 | 5/8 | 13/16 | 1 7/16 | 13/16 | 1 1/8 |
| 607-0607 | 3/4 | .752 | 1.125 | 1 5/16 | 7/8 | 13/16 | 1 11/16 | 7/8 | 1 3/16 |
| 607-0807 | 1 | 1.002 | 1.500 | 1 11/16 | 7/8 | 13/16 | 1 11/16 | 1 1/16 | 1 3/8 |
| 607-1008 | 1 1/4 | 1.252 | 1.750 | 1 15/16 | 1 1/8 | 13/16 | 1 15/16 | 1 7/32 | 1 17/32 |
| 607-1209 | 1 1/2 | 1.502 | 2.000 | 2 3/16 | 1 3/8 | 13/16 | 2 3/16 | 1 11/32 | 1 21/32 |
| 607-1410 | 1 3/4 | 1.752 | 2.250 | 2 1/2 | 1 3/8 | 1 | 2 3/8 | 1 1/2 | 1 13/16 |
| 607-1612 | 2 | 2.002 | 2.500 | 2 7/8 | 1 13/16 | 1 | 2 13/16 | 1 45/64 | 2 1/64 |
| 607-2012 | 2 1/2 | 2.502 | 3.250 | 3 5/8 | 1 13/16 | 1 | 2 13/16 | 2 25/64 | 2 25/64 |
| 607-2412 | 3 | 3.002 | 3.750 | 4 1/8 | 1 13/16 | 1 | 2 13/16 | 2 11/32 | 2 21/32 |

Clamps for Assembly

| Catalog Number | Inside Dia. A Nom. | Number of Clamps |
|----------------|--------------------|------------------|
| 899-9025 | 1 | 2 |
| 899-9125 | 1 1/4 | 3 |
| 899-9125 | 1 1/2 | 3 |
| 899-9125 | 1 3/4 | 4 |
| 899-9125 | 2 | 4 |
| 899-9125 | 2 1/2 | 4 |
| 899-9125 | 3 | 4 |

PRECISION DEMOUNTABLE BUSHINGS



For Plain Bearing Applications

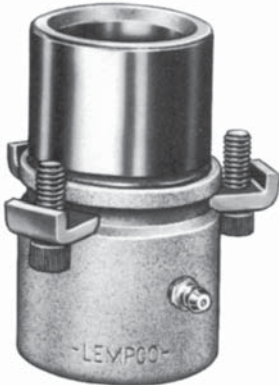

SHOULDER – Steel

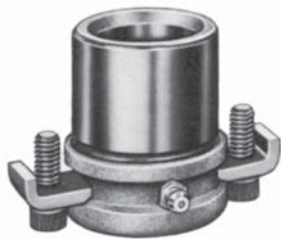

SHORT SHOULDER – Steel



EXTRA LONG SHOULDER – Steel



SHOULDER – Bronze

LEMPCO Precision Demountable Bushings include the Steel Shoulder, Steel Short Shoulder, Steel Extra Long Shoulder types, and the Bronze Shoulder and Bronze Plated Shoulder and Short Shoulder types. The Bronze Plated bushings are described on page 22.

All LEMPCO Demountable Bushings are designed for tap fitting. They should not be pressed in. They will not require select fitting, honing or modification of any kind if mounted in accordance with instructions on page 30 of this catalog.

SHOULDER – Steel

| Inside Dia. A | | B | C | E | F | L | Radius | | Catalog Number |
|-------------------------------|-------|-------|---------------------------------|---------------------------------|-------------------------------|---------------------------------|---------------------------------|---------------------------------|----------------|
| Nom. | Dec. | | | | | | M | N | |
| 1 | 1.002 | 1.500 | 1 ¹¹ / ₁₆ | 7/8 | 1 ³ / ₄ | 2 ⁵ / ₈ | 1 ¹ / ₁₆ | 1 ³ / ₈ | 664-0811 |
| 1 ¹ / ₄ | 1.252 | 1.750 | 1 ¹⁵ / ₁₆ | 1 ¹ / ₈ | 2 | 3 ¹ / ₈ | 1 ⁷ / ₃₂ | 1 ¹⁷ / ₃₂ | 664-1013 |
| 1 ¹ / ₂ | 1.502 | 2.000 | 2 ³ / ₁₆ | 1 ³ / ₈ | 2 | 3 ³ / ₈ | 1 ¹¹ / ₃₂ | 1 ²¹ / ₃₂ | 664-1214 |
| 1 ³ / ₄ | 1.752 | 2.250 | 2 ¹ / ₂ | 1 ³ / ₈ | 2 | 3 ³ / ₈ | 1 ¹ / ₂ | 1 ¹³ / ₁₆ | 664-1414 |
| 2 | 2.002 | 2.500 | 2 ⁷ / ₈ | 1 ¹³ / ₁₆ | 2 | 3 ¹³ / ₁₆ | 1 ⁴⁵ / ₆₄ | 2 ¹ / ₆₄ | 664-1616 |
| 2 ¹ / ₂ | 2.502 | 3.250 | 3 ⁵ / ₈ | 1 ¹³ / ₁₆ | 2 ¹ / ₂ | 4 ⁵ / ₁₆ | 2 ⁵ / ₆₄ | 2 ²⁵ / ₆₄ | 664-2018 |
| 3 | 3.002 | 3.750 | 4 ¹ / ₈ | 1 ¹³ / ₁₆ | 2 ¹ / ₂ | 4 ⁵ / ₁₆ | 2 ¹¹ / ₃₂ | 2 ²¹ / ₃₂ | 664-2418 |

EXTRA LONG SHOULDER – Steel

| Inside Dia. A | | B | C | E | F | L | Radius | | Catalog Number |
|-------------------------------|-------|-------|---------------------------------|---------------------------------|-------------------------------|--------------------------------|---------------------------------|---------------------------------|----------------|
| Nom. | Dec. | | | | | | M | N | |
| 1 | 1.002 | 1.500 | 1 ¹¹ / ₁₆ | 7/8 | 3 | 3 ⁷ / ₈ | 1 ¹ / ₁₆ | 1 ³ / ₈ | 655-0816 |
| 1 ¹ / ₄ | 1.252 | 1.750 | 1 ¹⁵ / ₁₆ | 1 ¹ / ₈ | 3 | 4 ¹ / ₈ | 1 ⁷ / ₃₂ | 1 ¹⁷ / ₃₂ | 655-1017 |
| 1 ¹ / ₂ | 1.502 | 2.000 | 2 ³ / ₁₆ | 1 ³ / ₈ | 3 | 4 ³ / ₈ | 1 ¹¹ / ₃₂ | 1 ²¹ / ₃₂ | 655-1218 |
| 1 ³ / ₄ | 1.752 | 2.250 | 2 ¹ / ₂ | 1 ³ / ₈ | 3 | 4 ³ / ₈ | 1 ¹ / ₂ | 1 ¹³ / ₁₆ | 655-1418 |
| 2 | 2.002 | 2.500 | 2 ⁷ / ₈ | 1 ¹³ / ₁₆ | 3 ¹ / ₂ | 5 ⁵ / ₁₆ | 1 ⁴⁵ / ₆₄ | 2 ¹ / ₆₄ | 655-1622 |
| 2 ¹ / ₂ | 2.502 | 3.250 | 3 ⁵ / ₈ | 1 ¹³ / ₁₆ | 3 ¹ / ₂ | 5 ⁵ / ₁₆ | 2 ⁵ / ₆₄ | 2 ²⁵ / ₆₄ | 655-2022 |
| 3 | 3.002 | 3.750 | 4 ¹ / ₈ | 1 ¹⁵ / ₁₆ | 3 ¹ / ₂ | 5 ⁷ / ₁₆ | 2 ¹¹ / ₃₂ | 2 ²¹ / ₃₂ | 655-2422 |

SHOULDER – Bronze

| Inside Dia. A | | B | C | E | F | L | Radius | | Catalog Number |
|-------------------------------|-------|----------|---------------------------------|---------------------------------|-------------------------------|---------------------------------|---------------------------------|---------------------------------|----------------|
| Nom. | Dec. | | | | | | M | N | |
| 1 | 1.002 | 1.500 | 1 ¹¹ / ₁₆ | 7/8 | 1 ³ / ₄ | 2 ⁵ / ₈ | 1 ¹ / ₁₆ | 1 ³ / ₈ | 648-0811 |
| 1 ¹ / ₄ | 1.252 | 1.750 | 1 ¹⁵ / ₁₆ | 1 ¹ / ₈ | 2 | 3 ¹ / ₈ | 1 ⁷ / ₃₂ | 1 ¹⁷ / ₃₂ | 648-1013 |
| 1 ¹ / ₂ | 1.502 | 2.000 | 2 ³ / ₁₆ | 1 ³ / ₈ | 2 | 3 ³ / ₈ | 1 ¹¹ / ₃₂ | 1 ²¹ / ₃₂ | 648-1214 |
| 1 ³ / ₄ | 1.752 | 2.250 | 2 ¹ / ₂ | 1 ³ / ₈ | 2 | 3 ³ / ₈ | 1 ¹ / ₂ | 1 ¹³ / ₁₆ | 648-1414 |
| 2 | 2.002 | 2.500 | 2 ⁷ / ₈ | 1 ¹³ / ₁₆ | 2 | 3 ¹³ / ₁₆ | 1 ⁴⁵ / ₆₄ | 2 ¹ / ₆₄ | 648-1616 |
| 2 ¹ / ₂ | 2.502 | 3.250 | 3 ⁵ / ₈ | 1 ¹³ / ₁₆ | 2 ¹ / ₂ | 4 ⁵ / ₁₆ | 2 ⁵ / ₆₄ | 2 ²⁵ / ₆₄ | 648-2018 |
| 3 | 3.002 | 3.750 | 4 ¹ / ₈ | 1 ¹³ / ₁₆ | 2 ¹ / ₂ | 4 ⁵ / ₁₆ | 2 ¹¹ / ₃₂ | 2 ²¹ / ₃₂ | 648-2418 |

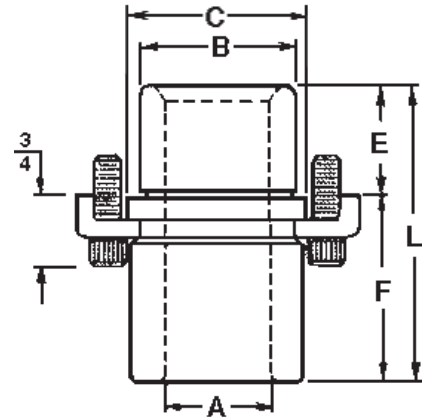

SHORT SHOULDER – Steel

| Inside Dia. A | | B | C | E | F | L | Radius | | Catalog Number |
|-------------------------------|-------|----------|---------------------------------|---------------------------------|--------------------------------|---------------------------------|---------------------------------|---------------------------------|----------------|
| Nom. | Dec. | | | | | | M | N | |
| 1 | 1.002 | 1.500 | 1 ¹¹ / ₁₆ | 7/8 | 1 ³ / ₁₆ | 1 ¹¹ / ₁₆ | 1 ¹ / ₁₆ | 1 ³ / ₈ | 663-0807 |
| 1 ¹ / ₄ | 1.252 | 1.750 | 1 ¹⁵ / ₁₆ | 1 ¹ / ₈ | 1 ³ / ₁₆ | 1 ¹⁵ / ₁₆ | 1 ⁷ / ₃₂ | 1 ¹⁷ / ₃₂ | 663-1008 |
| 1 ¹ / ₂ | 1.502 | 2.000 | 2 ³ / ₁₆ | 1 ³ / ₈ | 1 ³ / ₁₆ | 2 ³ / ₁₆ | 1 ¹¹ / ₃₂ | 1 ²¹ / ₃₂ | 663-1209 |
| 1 ³ / ₄ | 1.752 | 2.250 | 2 ¹ / ₂ | 1 ³ / ₈ | 1 | 2 ³ / ₈ | 1 ¹ / ₂ | 1 ¹³ / ₁₆ | 663-1410 |
| 2 | 2.002 | 2.500 | 2 ⁷ / ₈ | 1 ¹³ / ₁₆ | 1 | 2 ¹³ / ₁₆ | 1 ⁴⁵ / ₆₄ | 2 ¹ / ₆₄ | 663-1612 |
| 2 ¹ / ₂ | 2.502 | 3.250 | 3 ⁵ / ₈ | 1 ¹³ / ₁₆ | 1 | 2 ¹³ / ₁₆ | 2 ⁵ / ₆₄ | 2 ²⁵ / ₆₄ | 663-2012 |
| 3 | 3.002 | 3.750 | 4 ¹ / ₈ | 1 ¹³ / ₁₆ | 1 | 2 ¹³ / ₁₆ | 2 ¹¹ / ₃₂ | 2 ²¹ / ₃₂ | 663-2412 |

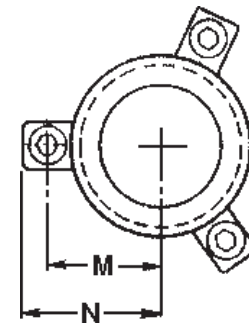

CLAMPS FOR ASSEMBLY

| Inside Dia. A | | Number Clamps |
|--|-----------|---------------|
| Nom. | Clamp No. | |
| 1/2 to 1 | 899-9025 | 2 |
| 1 ¹ / ₄ to 1 ¹ / ₂ | 899-9125 | 3 |
| 1 ³ / ₄ to 3 | 899-9125 | 4 |

NOTE: The “C” dimension measurement is from the outside edge of the flange to the opposite outside edge.

PRECISION BRONZE-PLATED DEMOUNTABLE BUSHINGS



For Plain Bearing Applications

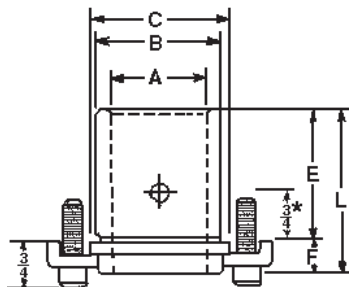
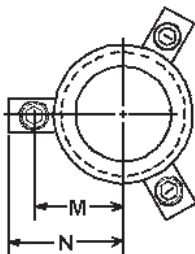
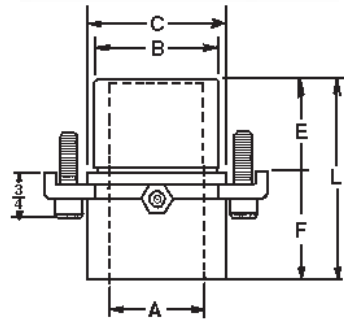

LEMPCO Precision Bronze Plated Demountable Bushings are designed for use under high speed operating conditions. They are intended for tap fitting, to be held securely with clamps and cap screws.

These bushings must not be pressed in and must not be honed.

See page 30 for mounting instructions.

Clamps and screws are provided with bushings, from two to four sets per bushing, depending on diameter.

SHOULDER – Bronze Plated

| Inside Dia. A | | B | C | E | F | L | Radius | | Catalog Number |
|-------------------------------|-------|-------|--------------------------------|-------------------------------|-------------------------------|-------------------------------|--------|-------|----------------|
| Nom. | Dec. | | | | | | M | N | |
| 1 | 1.002 | 1.500 | 1 ³ / ₄ | 7 ⁷ / ₈ | 1 ¹ / ₄ | 2 ¹ / ₈ | 1.072 | 1.385 | 624-0809 |
| 1 ¹ / ₄ | 1.252 | 1.750 | 2 ¹ / ₁₆ | 1 ¹ / ₈ | 1 ¹ / ₂ | 2 ⁵ / ₈ | 1.281 | 1.703 | 624-1011 |
| 1 ¹ / ₂ | 1.502 | 2.000 | 2 ⁵ / ₁₆ | 1 ³ / ₈ | 1 ¹ / ₂ | 2 ⁷ / ₈ | 1.411 | 1.833 | 624-1212 |
| 1 ³ / ₄ | 1.752 | 2.250 | 2 ⁵ / ₈ | 1 ⁵ / ₈ | 1 ¹ / ₂ | 3 ¹ / ₈ | 1.567 | 1.989 | 624-1413 |
| 2 | 2.002 | 2.500 | 3 ¹ / ₃₂ | 1 ⁷ / ₈ | 1 ¹ / ₂ | 3 ³ / ₈ | 1.782 | 2.204 | 624-1614 |
| 2 ¹ / ₂ | 2.502 | 3.000 | 3 ⁵ / ₈ | 1 ⁷ / ₈ | 2 | 3 ⁷ / ₈ | 2.086 | 2.508 | 624-2016 |
| 3 | 3.002 | 3.625 | 4 ³ / ₈ | 1 ⁷ / ₈ | 2 | 3 ⁷ / ₈ | 2.468 | 2.889 | 624-2416 |

SHORT SHOULDER – Bronze Plated

| Inside Dia. A | | B | C | E | F | L | Radius | | Catalog Number |
|-------------------------------|-------|-------|---------------------------------|-------------------------------|-------------------------------|-------------------------------|--------|-------|----------------|
| Nom. | Dec. | | | | | | M | N | |
| 1 | 1.002 | 1.500 | 1 ³ / ₄ | 1 ³ / ₈ | 1 ¹ / ₂ | 1 ⁷ / ₈ | 1.082 | 1.395 | 623-0808 |
| 1 ¹ / ₄ | 1.252 | 1.750 | 2 ¹ / ₁₆ | 1 ⁷ / ₈ | 1 ¹ / ₂ | 2 ³ / ₈ | 1.286 | 1.708 | 623-1010 |
| 1 ¹ / ₂ | 1.502 | 2.000 | 2 ⁵ / ₁₆ | 1 ⁷ / ₈ | 1 ¹ / ₂ | 2 ³ / ₈ | 1.411 | 1.833 | 623-1210 |
| 1 ³ / ₄ | 1.752 | 2.250 | 2 ⁵ / ₈ | 2 ³ / ₈ | 1 ¹ / ₂ | 2 ⁷ / ₈ | 1.567 | 1.989 | 623-1412 |
| 2 | 2.002 | 2.500 | 2 ¹⁵ / ₁₆ | 2 ³ / ₈ | 1 ¹ / ₂ | 2 ⁷ / ₈ | 1.734 | 2.156 | 623-1612 |
| 2 ¹ / ₂ | 2.502 | 3.000 | 3 ³ / ₈ | 2 ⁵ / ₈ | 3 ³ / ₈ | 3 | 1.959 | 2.381 | 623-2012 |
| 3 | 3.002 | 3.500 | 3 ⁷ / ₈ | 3 ⁵ / ₈ | 3 ³ / ₈ | 4 | 2.214 | 2.636 | 623-2416 |

NOTE: The "C" dimension measurement is from the outside edge of the flange to the opposite outside edge.

*1¹/₄" on 2¹/₂ and 3" diameter bushings



PRECISION PRESS FIT BUSHINGS

For Plain Bearing Applications

Precision Press Fit Bushings for LEMPCO plain bearing assemblies are offered in five designs: the Steel Shoulder, Short Shoulder, Short Sleeve, Extra Long Sleeve and Bronze Shoulder Bushings.

Since all of these bushings are designed for press fitting, a nominal allowance is provided on the inside diameter for honing after assembly. Mounting instructions on page 30 of this catalog should be strictly followed.



**SHOULDER
Bronze**



**SHOULDER
Steel**



**SHORT SHOULDER
Steel**



**EXTRA LONG SLEEVE
Steel**



**SHORT SLEEVE
Steel**

SHOULDER – Steel or Bronze

| Inside Dia. A | | B | C | E | F | L | Catalog Numbers Steel | Catalog Numbers Bronze |
|-------------------------|-------|----------|----------|----------|----------|----------|--------------------------|---------------------------|
| Nom. | Dec. | | | | | | | |
| 1/2 | .502 | .815 | 15/16 | 5/8 | 1 1/2 | 2 1/8 | 662-0409 | 644-0409 |
| 5/8 | .627 | 1.002 | 13/16 | 5/8 | 1 1/2 | 2 1/8 | 662-0509 | 644-0509 |
| 3/4 | .752 | 1.127 | 15/16 | 7/8 | 1 3/4 | 2 5/8 | 662-0611 | 644-0611 |
| 1 | 1.002 | 1.502 | 1 1/16 | 7/8 | 1 3/4 | 2 5/8 | 662-0811 | 644-0811 |
| 1 1/4 | 1.252 | 1.752 | 1 15/16 | 1 1/8 | 2 | 3 1/8 | 662-1013 | 644-1013 |
| 1 1/2 | 1.502 | 2.002 | 2 3/16 | 1 3/8 | 2 | 3 3/8 | 662-1214 | 644-1214 |
| 1 3/4 | 1.752 | 2.252 | 2 1/2 | 1 3/8 | 2 | 3 3/8 | 662-1414 | 644-1414 |
| 2 | 2.002 | 2.502 | 2 7/8 | 1 13/16 | 2 | 3 13/16 | 662-1616 | 644-1616 |
| 2 1/2 | 2.502 | 3.252 | 3 5/8 | 1 13/16 | 2 1/2 | 4 5/16 | 662-2018 | 644-2018 |
| 3 | 3.002 | 3.752 | 4 1/8 | 1 13/16 | 2 1/2 | 4 5/16 | 662-2418 | 644-2418 |

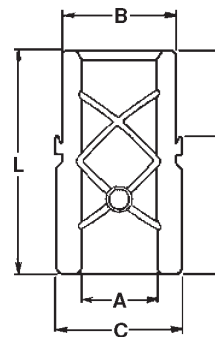

SHORT SHOULDER – Steel

| Inside Dia. A | | B | C | E | F | L | Catalog Numbers |
|-------------------------|-------|----------|----------|----------|----------|----------|-----------------|
| Nom. | Dec. | | | | | | |
| 1/2 | .502 | .815 | 15/16 | 5/8 | 13/16 | 1 7/16 | 661-0406 |
| 5/8 | .627 | 1.002 | 13/16 | 5/8 | 13/16 | 1 7/16 | 661-0506 |
| 3/4 | .752 | 1.127 | 15/16 | 7/8 | 13/16 | 1 11/16 | 661-0607 |
| 1 | 1.002 | 1.502 | 1 1/16 | 7/8 | 13/16 | 1 11/16 | 661-0807 |
| 1 1/4 | 1.252 | 1.752 | 1 15/16 | 1 1/8 | 13/16 | 1 15/16 | 661-1008 |
| 1 1/2 | 1.502 | 2.002 | 2 3/16 | 1 3/8 | 13/16 | 2 3/16 | 661-1209 |
| 1 3/4 | 1.752 | 2.252 | 2 1/2 | 1 3/8 | 1 | 2 3/8 | 661-1410 |
| 2 | 2.002 | 2.502 | 2 7/8 | 1 13/16 | 1 | 2 13/16 | 661-1612 |
| 2 1/2 | 2.502 | 3.252 | 3 5/8 | 1 13/16 | 1 | 2 13/16 | 661-2012 |
| 3 | 3.002 | 3.752 | 4 1/8 | 1 13/16 | 1 | 2 13/16 | 661-2412 |

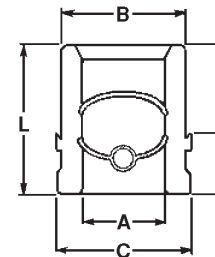

SHORT SLEEVE or EXTRA LONG SLEEVE – Steel

| Inside Dia. A | | B | L | | Catalog Numbers | |
|-------------------------|-------|----------|--------------|----------------|-----------------|----------------|
| Nom. | Dec. | | Short Sleeve | Ex. Lg. Sleeve | Short Sleeve | Ex. Lg. Sleeve |
| 1/2 | .502 | .815 | 1 1/2 | 3 | 601-0406 | 603-0412 |
| 5/8 | .627 | 1.002 | 1 1/2 | 3 | 601-0506 | 603-0512 |
| 3/4 | .752 | 1.127 | 1 3/4 | 3 | 601-0607 | 603-0612 |
| 1 | 1.002 | 1.502 | 1 3/4 | 3 | 601-0807 | 603-0812 |
| 1 1/4 | 1.252 | 1.752 | 2 | 3 | 601-1008 | 603-1012 |
| 1 1/2 | 1.502 | 2.002 | 2 | 3 | 601-1208 | 603-1212 |
| 1 3/4 | 1.752 | 2.252 | — | 3 | — | 603-1412 |
| 2 | 2.002 | 2.502 | — | 3 | — | 603-1612 |
| 2 1/2 | 2.502 | 3.252 | — | 3 | — | 603-2012 |

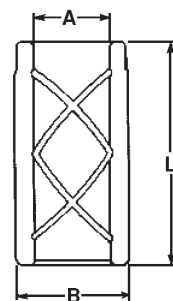

SHOULDER GUIDE POST BUSHINGS



For Plain Bearing Applications

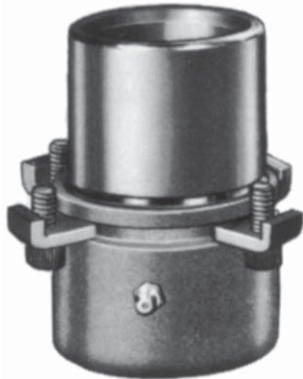

SHOULDER – Bronze



SHORT SHOULDER –
Bronze Plated



SHOULDER – Steel

Bronze Shoulder bushings may be either tap or press fitted. When tap fitted, these bushings will not require select fitting, honing or other modification if mounting instructions on page 30 are strictly followed.

Bronze Plated Shoulder Bushings are for demountable use only, consequently must be tap fitted. Instructions on page 30 should be strictly followed.

These bushings should not be pressed in and must not be honed.

Mounting diameter lead edge should be smoothly blended after grinding to prevent broaching of bore or drift component during assembly.

SHORT SHOULDER – Steel

| Inside Dia. | | B | C | E | F | L | Radius | | Catalog Number |
|-------------------------------|-------|-------|---------------------------------|---------------------------------|-------------------------------|---------------------------------|---------------------------------|---------------------------------|----------------|
| Nom. | Dec. | | | | | | M | N | |
| 1 | 1.002 | 1.509 | 1 ¹¹ / ₁₆ | ⁷ / ₈ | ¹³ / ₁₆ | 1 ¹¹ / ₁₆ | 1 ¹ / ₁₆ | ¹³ / ₈ | 625-0807 |
| 1 ¹ / ₄ | 1.252 | 1.759 | 1 ¹⁵ / ₁₆ | 1 ¹ / ₈ | ¹³ / ₁₆ | 1 ¹⁵ / ₁₆ | 1 ⁷ / ₃₂ | 1 ¹⁷ / ₃₂ | 625-1008 |
| 1 ¹ / ₂ | 1.502 | 2.009 | 2 ³ / ₁₆ | ¹³ / ₈ | ¹³ / ₁₆ | 2 ³ / ₁₆ | 1 ¹¹ / ₃₂ | 1 ²¹ / ₃₂ | 625-1209 |
| 1 ³ / ₄ | 1.752 | 2.259 | 2 ¹ / ₂ | ¹³ / ₈ | 1 | 2 ³ / ₈ | 1 ¹ / ₂ | 1 ¹³ / ₁₆ | 625-1410 |
| 2 | 2.002 | 2.509 | 2 ⁷ / ₈ | 1 ¹³ / ₁₆ | 1 | 2 ¹³ / ₁₆ | 1 ⁴⁵ / ₆₄ | 2 ¹ / ₆₄ | 625-1612 |
| 2 ¹ / ₂ | 2.502 | 3.259 | 3 ⁵ / ₈ | 1 ¹³ / ₁₆ | 1 | 2 ¹³ / ₁₆ | 2 ⁵ / ₆₄ | 2 ²⁵ / ₆₄ | 625-2012 |

SHORT SHOULDER – Bronze Plated

| Inside Dia. | | B | C | E | F | L | Radius | | Catalog Number |
|-------------------------------|-------|-------|---------------------------------|-------------------------------|-----------------------------|-------------------------------|---------------------------------|---------------------------------|----------------|
| Nom. | Dec. | | | | | | M | N | |
| 1 | 1.002 | 1.509 | 1 ³ / ₄ | ¹³ / ₈ | ¹ / ₂ | 1 ⁷ / ₈ | 1 ¹ / ₁₆ | ¹³ / ₈ | 621-0808 |
| 1 ¹ / ₄ | 1.252 | 1.759 | 2 ¹ / ₁₆ | 1 ⁷ / ₈ | ¹ / ₂ | 2 ³ / ₈ | 1 ⁷ / ₃₂ | 1 ¹⁷ / ₃₂ | 621-1010 |
| 1 ¹ / ₂ | 1.502 | 2.009 | 2 ⁵ / ₁₆ | 1 ⁷ / ₈ | ¹ / ₂ | 2 ³ / ₈ | 1 ¹¹ / ₃₂ | 1 ²¹ / ₃₂ | 621-1210 |
| 1 ³ / ₄ | 1.752 | 2.259 | 2 ⁵ / ₈ | 2 ³ / ₈ | ¹ / ₂ | 2 ⁷ / ₈ | 1 ¹ / ₂ | 1 ¹³ / ₁₆ | 621-1412 |
| 2 | 2.002 | 2.509 | 2 ¹⁵ / ₁₆ | 2 ³ / ₈ | ¹ / ₂ | 2 ⁷ / ₈ | 1 ⁴³ / ₆₄ | 1 ⁶¹ / ₆₄ | 621-1612 |
| 2 ¹ / ₂ | 2.502 | 3.009 | 3 ³ / ₈ | 2 ⁵ / ₈ | ³ / ₈ | 3 | 1 ⁵⁷ / ₆₄ | 2 ¹¹ / ₆₄ | 621-2012 |



SHOULDER GUIDE POST BUSHINGS

For Plain Bearing Applications

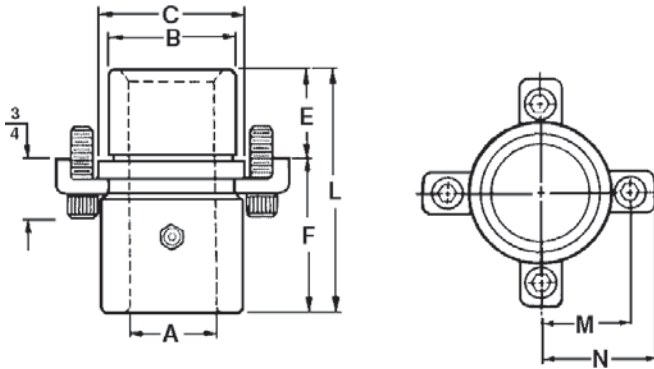

SHOULDER – Steel

| Inside Dia. A | | B | C | E | F | L | Radius | | Catalog Number |
|-------------------------------|-------|-------|---------------------------------|---------------------------------|-------------------------------|---------------------------------|---------------------------------|---------------------------------|----------------|
| Nom. | Dec. | | | | | | M | N | |
| 1 | 1.002 | 1.509 | 1 ¹¹ / ₁₆ | 7/8 | 1 ³ / ₄ | 2 ⁵ / ₈ | 1 ¹ / ₁₆ | 1 ³ / ₈ | 626-0811 |
| 1 ¹ / ₄ | 1.252 | 1.759 | 1 ¹⁵ / ₁₆ | 1 ¹ / ₈ | 2 | 3 ¹ / ₈ | 1 ⁷ / ₃₂ | 1 ¹⁷ / ₃₂ | 626-1013 |
| 1 ¹ / ₂ | 1.502 | 2.009 | 2 ³ / ₁₆ | 1 ³ / ₈ | 2 | 3 ³ / ₈ | 1 ¹¹ / ₃₂ | 1 ²¹ / ₃₂ | 626-1214 |
| 1 ³ / ₄ | 1.752 | 2.259 | 2 ¹ / ₂ | 1 ³ / ₈ | 2 | 3 ³ / ₈ | 1 ¹ / ₂ | 1 ¹³ / ₁₆ | 626-1414 |
| 2 | 2.002 | 2.509 | 2 ⁷ / ₈ | 1 ¹³ / ₁₆ | 2 | 3 ¹³ / ₁₆ | 1 ⁴⁵ / ₆₄ | 2 ¹ / ₆₄ | 626-1616 |
| 2 ¹ / ₂ | 2.502 | 3.259 | 3 ⁵ / ₈ | 1 ¹³ / ₁₆ | 2 ¹ / ₂ | 4 ⁵ / ₁₆ | 2 ⁵ / ₆₄ | 2 ²⁵ / ₆₄ | 626-2018 |

CLAMPS FOR TAP FITTING

| Inside Dia. A | | Number Clamps |
|-------------------------------|-----------|---------------|
| Nom. | Clamp No. | |
| 1 | 899-9025 | 2 |
| 1 ¹ / ₄ | 899-9125 | 3 |
| 1 ¹ / ₂ | 899-9125 | 3 |
| 1 ³ / ₄ | 899-9125 | 4 |
| 2 | 899-9125 | 4 |
| 2 ¹ / ₂ | 899-9125 | 4 |

SHOULDER – Bronze

| Inside Dia. A | | B | C | E | F | L | Radius | | Catalog Number |
|-------------------------------|-------|-------|---------------------------------|---------------------------------|-------------------------------|---------------------------------|---------------------------------|---------------------------------|----------------|
| Nom. | Dec. | | | | | | M | N | |
| 1 | 1.002 | 1.509 | 1 ¹¹ / ₁₆ | 7/8 | 1 ³ / ₄ | 2 ⁵ / ₈ | 1 ¹ / ₁₆ | 1 ³ / ₈ | 629-0811 |
| 1 ¹ / ₄ | 1.252 | 1.759 | 1 ¹⁵ / ₁₆ | 1 ¹ / ₈ | 2 | 3 ¹ / ₈ | 1 ⁷ / ₃₂ | 1 ¹⁷ / ₃₂ | 629-1013 |
| 1 ¹ / ₂ | 1.502 | 2.009 | 2 ³ / ₁₆ | 1 ³ / ₈ | 2 | 3 ³ / ₈ | 1 ¹¹ / ₃₂ | 1 ²¹ / ₃₂ | 629-1214 |
| 1 ³ / ₄ | 1.752 | 2.259 | 2 ¹ / ₂ | 1 ³ / ₈ | 2 | 3 ³ / ₈ | 1 ¹ / ₂ | 1 ¹³ / ₁₆ | 629-1414 |
| 2 | 2.002 | 2.509 | 2 ⁷ / ₈ | 1 ¹³ / ₁₆ | 2 | 3 ¹³ / ₁₆ | 1 ⁴⁵ / ₆₄ | 2 ¹ / ₆₄ | 629-1616 |
| 2 ¹ / ₂ | 2.502 | 3.259 | 3 ⁵ / ₈ | 1 ¹³ / ₁₆ | 2 ¹ / ₂ | 4 ⁵ / ₁₆ | 2 ⁵ / ₆₄ | 2 ²⁵ / ₆₄ | 629-2018 |

NOTE: The "C" dimension measurement is from the outside edge of the flange to the opposite outside edge.

SHOULDER – Bronze Plated

| Inside Dia. A | | B | C | E | F | L | Radius | | Catalog Number |
|-------------------------------|-------|-------|--------------------------------|-------------------------------|-------------------------------|-------------------------------|---------------------------------|---------------------------------|----------------|
| Nom. | Dec. | | | | | | M | N | |
| 1 | 1.002 | 1.509 | 1 ³ / ₄ | 7/8 | 1 ¹ / ₄ | 2 ¹ / ₈ | 1 ¹ / ₁₆ | 1 ³ / ₈ | 622-0809 |
| 1 ¹ / ₄ | 1.252 | 1.759 | 2 ¹ / ₁₆ | 1 ¹ / ₈ | 1 ¹ / ₂ | 2 ⁵ / ₈ | 1 ⁷ / ₃₂ | 1 ¹⁷ / ₃₂ | 622-1011 |
| 1 ¹ / ₂ | 1.502 | 2.009 | 2 ⁵ / ₁₆ | 1 ³ / ₈ | 1 ¹ / ₂ | 2 ⁷ / ₈ | 1 ¹¹ / ₃₂ | 1 ²¹ / ₃₂ | 622-1212 |
| 1 ³ / ₄ | 1.752 | 2.259 | 2 ⁵ / ₈ | 1 ⁵ / ₈ | 1 ¹ / ₂ | 3 ¹ / ₈ | 1 ¹ / ₂ | 1 ¹³ / ₁₆ | 622-1413 |
| 2 | 2.002 | 2.509 | 3 ¹ / ₃₂ | 1 ⁷ / ₈ | 1 ¹ / ₂ | 3 ³ / ₈ | 1 ⁴⁵ / ₆₄ | 2 ¹ / ₆₄ | 622-1614 |
| 2 ¹ / ₂ | 2.502 | 3.009 | 3 ⁵ / ₈ | 1 ⁷ / ₈ | 2 | 3 ⁷ / ₈ | 2 ¹ / ₃₂ | 2 ⁵ / ₁₆ | 622-2016 |

FLANGED DEMOUNTABLE GUIDE POSTS



For Plain Bearing Applications



The **LEMPCO** Flanged Demountable Guide Post for plain bearing assemblies is precision ground for longest wear with all **LEMPCO** plain bearing bushings, steel, bronze, bronze-plated, precision grade.

This removable type post is tap fit into the dieholder bore with the flange flush to the ground surface of the shoe. It is secured with clamps and cap screws. It may be removed, and on reinstallation, the die set will register accurately. The end radius is ground with the tool marks running in the direction of vertical motion to minimize wear from engagement and disengagement.

| Post A | Flange B | Diameter | | E | F | Radius | | L | Catalog Number |
|--|--------------------------------|------------------|--------------------------------|-------------------------------|--------------------------------|---------------------------------|----------------------------------|-------------------------------|-------------------|
| | | C | | | | M | N | | |
| | | | | | | | | | |
| 1 (1.002) | 1 ⁵ / ₁₆ | 1.0009 1.0005 | 1 ³ / ₁₆ | 2 ³ / ₄ | 1 ³ / ₁₆ | 1 ¹ / ₈ | 3 clamps Part No. 899-9225 | 4 | 506-0816 |
| | | | | | | | | 4 ¹ / ₄ | 506-0817 |
| | | | | | | | | 4 ¹ / ₂ | 506-0818 |
| | | | | | | | | 4 ³ / ₄ | 506-0819 |
| | | | | | | | | 5 | 506-0820 |
| | | | | | | | | 5 ¹ / ₄ | 506-0821 |
| | | | | | | | | 5 ¹ / ₂ | 506-0822 |
| | | | | | | | | 5 ³ / ₄ | 506-0823 |
| | | | | | | | | 6 | 506-0824 |
| | | | | | | | | 6 ¹ / ₂ | 506-0826 |
| | | | | | | | | 7 | 506-0828 |
| | | | | | | | | 7 ¹ / ₂ | 506-0830 |
| | | | | | | | | 8 | 506-0832 |
| | | | | | | | | 8 ¹ / ₂ | 506-0834 |
| | | | | | | | | 9 | 506-0836 |
| 1 ¹ / ₄ (1.252) | 1 ⁹ / ₁₆ | 1.2509 1.2506 | 1 ³ / ₁₆ | 3 ¹ / ₄ | 1 ³ / ₁₆ | 1 ²⁵ / ₆₄ | 3 clamps Part No. 899-9325 | 4 ¹ / ₂ | 506-1018 |
| | | | | 3 ¹ / ₂ | | | | 4 ³ / ₄ | 506-1019 |
| | | | | 3 ³ / ₄ | | | | 5 | 506-1020 |
| | | | | 4 | | | | 5 ¹ / ₄ | 506-1021 |
| | | | | 4 ¹ / ₄ | | | | 5 ¹ / ₂ | 506-1022 |
| | | | | 4 ¹ / ₂ | | | | 5 ³ / ₄ | 506-1023 |
| | | | | 4 ³ / ₄ | | | | 6 | 506-1024 |
| | | | | 5 ¹ / ₄ | | | | 6 ¹ / ₂ | 506-1026 |
| | | | | 5 ³ / ₄ | | | | 7 | 506-1028 |
| | | | | 6 ¹ / ₄ | | | | 7 ¹ / ₂ | 506-1030 |
| | | | | 6 ³ / ₄ | | | | 8 | 506-1032 |
| | | | | 7 ¹ / ₄ | | | | 8 ¹ / ₂ | 506-1034 |
| 7 ³ / ₄ | 9 | 506-1036 | | | | | | | |
| 8 ³ / ₄ | 10 | 506-1040 | | | | | | | |
| 9 ³ / ₄ | 11 | 506-1044 | | | | | | | |
| 10 ³ / ₄ | 12 | 506-1048 | | | | | | | |
| 1 ¹ / ₂ (1.502) | 1 ⁷ / ₈ | 1.5009 1.5006 | 1 ⁷ / ₁₆ | 3 | 1 ⁷ / ₁₆ | 1 ¹⁷ / ₃₂ | 3 clamps Part No. 899-9325 | 4 ¹ / ₂ | 506-1218 |
| | | | | 3 ¹ / ₄ | | | | 4 ³ / ₄ | 506-1219 |
| | | | | 3 ¹ / ₂ | | | | 5 | 506-1220 |
| | | | | 3 ³ / ₄ | | | | 5 ¹ / ₄ | 506-1221 |
| | | | | 4 | | | | 5 ¹ / ₂ | 506-1222 |
| | | | | 4 ¹ / ₄ | | | | 5 ³ / ₄ | 506-1223 |
| | | | | 4 ¹ / ₂ | | | | 6 | 506-1224 |
| | | | | 5 | | | | 6 ¹ / ₂ | 506-1226 |
| | | | | 5 ¹ / ₂ | | | | 7 | 506-1228 |
| | | | | 6 | | | | 7 ¹ / ₂ | 506-1230 |
| | | | | 6 ¹ / ₂ | | | | 8 | 506-1232 |
| | | | | 7 | | | | 8 ¹ / ₂ | 506-1234 |
| | | | | 7 ¹ / ₂ | | | | 9 | 506-1236 |
| | | | | 8 ¹ / ₂ | | | | 10 | 506-1240 |
| | | | | 9 ¹ / ₂ | | | | 11 | 506-1244 |
| 10 ¹ / ₂ | 12 | 506-1248 | | | | | | | |



FLANGED DEMOUNTABLE GUIDE POSTS

For Plain Bearing Applications

| Post A | Diameter | | E | F | Radius | | L | Catalog Number |
|-----------------------------|------------------|------------------|--------------------|-------------------|--------------------|--------------------|------------------|-------------------|
| | Flange B | C | | | M | N | | |
| | | | | | | | | |
| 1 ^{3/4} (1.752) | 2 ^{1/4} | 1.7509 1.7506 | 1 ^{11/16} | 4 ^{1/4} | 1 ^{19/64} | 1 ^{45/64} | 6 | 506-1424 |
| | | | | 4 ^{3/4} | | | 6 ^{1/2} | 506-1426 |
| | | | | 5 ^{1/4} | | | 7 | 506-1428 |
| | | | | 5 ^{3/4} | | | 7 ^{1/2} | 506-1430 |
| | | | | 6 ^{1/4} | | | 8 | 506-1432 |
| | | | | 6 ^{3/4} | | | 8 ^{1/2} | 506-1434 |
| | | | | 7 ^{1/4} | | | 9 | 506-1436 |
| | | | | 8 ^{1/4} | | | 10 | 506-1440 |
| | | | | 9 ^{1/4} | | | 11 | 506-1444 |
| | | | | 10 ^{1/4} | | | 12 | 506-1448 |
| | | | | 12 ^{1/4} | | | 14 | 506-1456 |
| 2 (2.002) | 2 ^{1/2} | 2.0009 2.0006 | 1 ^{15/16} | 4 | 1 ^{27/64} | 1 ^{53/64} | 6 | 506-1624 |
| | | | | 4 ^{1/2} | | | 6 ^{1/2} | 506-1626 |
| | | | | 5 | | | 7 | 506-1628 |
| | | | | 5 ^{1/2} | | | 7 ^{1/2} | 506-1630 |
| | | | | 6 | | | 8 | 506-1632 |
| | | | | 6 ^{1/2} | | | 8 ^{1/2} | 506-1634 |
| | | | | 7 | | | 9 | 506-1636 |
| | | | | 8 | | | 10 | 506-1640 |
| | | | | 9 | | | 11 | 506-1644 |
| | | | | 10 | | | 12 | 506-1648 |
| | | | | 11 | | | 13 | 506-1652 |
| | | | | 12 | | | 14 | 506-1656 |
| | | | | 15 | | | 17 | 506-1668 |
| | | | | 18 | | | 20 | 506-1680 |
| 2 ^{1/2} (2.502) | 3 | 2.5009 2.5006 | 1 ^{15/16} | 6 | 1 ^{43/64} | 2 ^{5/64} | 8 | 506-2032 |
| | | | | 6 ^{1/2} | | | 8 ^{1/2} | 506-2034 |
| | | | | 7 | | | 9 | 506-2036 |
| | | | | 8 | | | 10 | 506-2040 |
| | | | | 9 | | | 11 | 506-2044 |
| | | | | 10 | | | 12 | 506-2048 |
| | | | | 11 | | | 13 | 506-2052 |
| | | | | 12 | | | 14 | 506-2056 |
| | | | | 15 | | | 17 | 506-2068 |
| | | | | 18 | | | 20 | 506-2080 |
| 3 (3.002) | 3 ^{1/2} | 3.0009 3.0006 | 2 ^{7/16} | 5 ^{1/2} | 1 ^{59/64} | 2 ^{21/64} | 8 | 506-2432 |
| | | | | 6 | | | 8 ^{1/2} | 506-2434 |
| | | | | 6 ^{1/2} | | | 9 | 506-2436 |
| | | | | 7 ^{1/2} | | | 10 | 506-2440 |
| | | | | 8 ^{1/2} | | | 11 | 506-2444 |
| | | | | 9 ^{1/2} | | | 12 | 506-2448 |
| | | | | 10 ^{1/2} | | | 13 | 506-2452 |
| | | | | 11 ^{1/2} | | | 14 | 506-2456 |
| | | | | 14 ^{1/2} | | | 17 | 506-2468 |
| | | | | 17 ^{1/2} | | | 20 | 506-2480 |

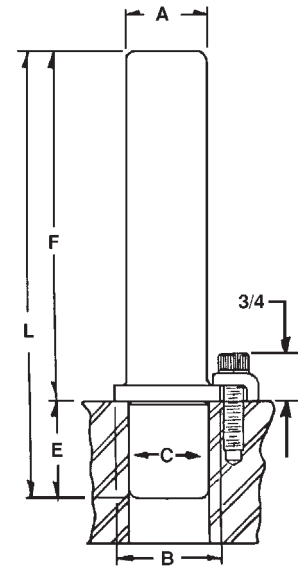

SHOULDER GUIDE POSTS



For Plain Bearing Applications

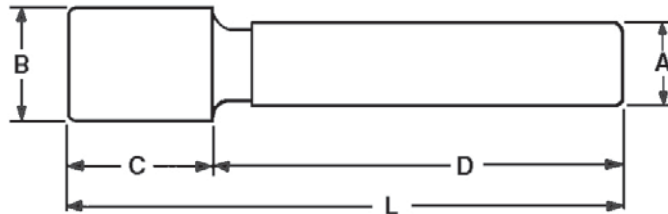

Shoulder Guide Posts are intended for use with Shoulder Guide Post Bushings and therefore the mounting diameters of the posts are the same as those of related bushings on the preceding page. These mounting diameters are a minimum of .007" over the size of Precision Press Fit Bushings and .009" over Precision Demountable Bushings so as to allow grind stock for precision fitting in the construction of new sets and to allow reboring where necessary to replace guide posts and bushings in used sets.

LEMPCO Shoulder Guide Posts are precision ground. Mounting instructions on page 30 of this catalog should be strictly followed. The mounting diameter lead edge should be smoothly blended after grinding to prevent hole broaching or drift during assembly.

| Diameter A | B | Length L | C | D | Catalog Numbers |
|--|-------------------------------|--|-------------------------------|--------------------------------|-------------------------------|
| 1 (1.002) | 1.509 | 4 ¹ / ₂ | 1 ³ / ₈ | 3 | 503-0818 |
| | | 5 | | 3 ¹ / ₂ | 503-0820 |
| | | 5 ¹ / ₂ | | 4 | 503-0822 |
| | | 6 | | 4 ¹ / ₂ | 503-0824 |
| | | 6 ¹ / ₂ | | 5 | 503-0826 |
| | | 7 | | 5 ¹ / ₂ | 503-0828 |
| | | 7 ¹ / ₂ | | 6 | 503-0830 |
| | | 8 | | 6 ¹ / ₂ | 503-0832 |
| 1 ¹ / ₄ (1.252) | 1.759 | 5 | 1 ⁷ / ₈ | 3 | 503-1020 |
| | | 5 ¹ / ₂ | | 3 ¹ / ₂ | 503-1022 |
| | | 6 | | 4 | 503-1024 |
| | | 6 ¹ / ₂ | | 4 ¹ / ₂ | 503-1026 |
| | | 7 | | 5 | 503-1028 |
| | | 7 ¹ / ₂ | | 5 ¹ / ₂ | 503-1030 |
| | | 8 | | 6 | 503-1032 |
| | | 8 ¹ / ₂ | | 6 ¹ / ₂ | 503-1034 |
| 1 ¹ / ₂ (1.502) | 2.009 | 7 | 2 ³ / ₈ | 4 ⁵ / ₈ | 503-1228 |
| | | 7 ¹ / ₂ | | 5 ¹ / ₈ | 503-1230 |
| | | 8 | | 5 ⁵ / ₈ | 503-1232 |
| | | 8 ¹ / ₂ | | 6 ¹ / ₈ | 503-1234 |
| | | 9 | | 6 ⁵ / ₈ | 503-1236 |
| | | 9 ¹ / ₂ | | 7 ¹ / ₈ | 503-1238 |
| | | 10 | | 7 ⁵ / ₈ | 503-1240 |
| | | 1 ³ / ₄ (1.752) | | 2.259 | 7 ¹ / ₂ |
| 8 | 5 ¹ / ₈ | | 503-1432 | | |
| 8 ¹ / ₂ | 5 ⁵ / ₈ | | 503-1434 | | |
| 9 | 6 ¹ / ₈ | | 503-1436 | | |
| 9 ¹ / ₂ | 6 ⁵ / ₈ | | 503-1438 | | |
| 10 | 7 ¹ / ₈ | | 503-1440 | | |
| 2 (2.002) | 2.509 | 8 | 3 ³ / ₈ | 4 ⁵ / ₈ | 503-1632 |
| | | 9 | | 5 ⁵ / ₈ | 503-1636 |
| | | 10 | | 6 ⁵ / ₈ | 503-1640 |
| | | 11 | | 7 ⁵ / ₈ | 503-1644 |
| | | 12 | | 8 ⁵ / ₈ | 503-1648 |
| | | 13 | | 9 ⁵ / ₈ | 503-1652 |
| 2 ¹ / ₂ (2.502) | 3.259 | 9 | 3 ⁷ / ₈ | 5 ¹ / ₈ | 503-2036 |
| | | 10 | | 6 ¹ / ₈ | 503-2040 |
| | | 11 | | 7 ¹ / ₈ | 503-2044 |
| | | 12 | | 8 ¹ / ₈ | 503-2048 |
| | | 13 | | 9 ¹ / ₈ | 503-2052 |
| | | 14 | | 10 ¹ / ₈ | 503-2056 |

NOTE: The 503 Series product line is not stocked, but is available as a special order.

For Plain Bearing Applications

LEMPCO's "501" series Plain Bearing Guide Posts are precision ground.



| Post Diameter A | Length L | Catalog Numbers |
|--------------------|-------------|-----------------|
| 1/2 (.502) | 3 1/2 | 501-0414 |
| | 4 | 501-0416 |
| | 4 1/4 | 501-0417 |
| | 4 1/2 | 501-0418 |
| | 4 3/4 | 501-0419 |
| | 5 | 501-0420 |
| | 5 1/4 | 501-0421 |
| | 5 1/2 | 501-0422 |
| 5/8 (.627) | 4 | 501-0516 |
| | 4 1/4 | 501-0517 |
| | 4 1/2 | 501-0518 |
| | 4 3/4 | 501-0519 |
| | 5 | 501-0520 |
| | 5 1/2 | 501-0522 |
| 3/4 (.752) | 4 | 501-0616 |
| | 4 1/4 | 501-0617 |
| | 4 1/2 | 501-0618 |
| | 4 3/4 | 501-0619 |
| | 5 | 501-0620 |
| 1 (1.002) | 4 | 501-0816 |
| | 4 1/4 | 501-0817 |
| | 4 1/2 | 501-0818 |
| | 4 3/4 | 501-0819 |
| | 5 | 501-0820 |
| | 5 1/4 | 501-0821 |
| | 5 1/2 | 501-0822 |
| | 5 3/4 | 501-0823 |
| | 6 | 501-0824 |
| | 6 1/2 | 501-0826 |
| | 7 | 501-0828 |
| | 7 1/2 | 501-0830 |
| | 8 | 501-0832 |
| | 8 1/2 | 501-0834 |
| | 9 | 501-0836 |
| | 10 | 501-0840 |
| 11 | 501-0844 | |
| 12 | 501-0848 | |

| Post Diameter A | Length L | Catalog Numbers |
|--------------------|-------------|-----------------|
| 1 1/4 (1.252) | 4 1/2 | 501-1018 |
| | 4 3/4 | 501-1019 |
| | 5 | 501-1020 |
| | 5 1/4 | 501-1021 |
| | 5 1/2 | 501-1022 |
| | 5 3/4 | 501-1023 |
| | 6 | 501-1024 |
| | 6 1/2 | 501-1026 |
| | 7 | 501-1028 |
| | 7 1/2 | 501-1030 |
| | 8 | 501-1032 |
| | 8 1/2 | 501-1034 |
| 1 1/2 (1.502) | 4 1/2 | 501-1218 |
| | 4 3/4 | 501-1219 |
| | 5 | 501-1220 |
| | 5 1/4 | 501-1221 |
| | 5 1/2 | 501-1222 |
| | 5 3/4 | 501-1223 |
| | 6 | 501-1224 |
| | 6 1/2 | 501-1226 |
| | 7 | 501-1228 |
| | 7 1/2 | 501-1230 |
| | 8 | 501-1232 |
| | 8 1/2 | 501-1234 |
| 1 3/4 (1.752) | 6 | 501-1424 |
| | 6 1/2 | 501-1426 |
| | 7 | 501-1428 |
| | 7 1/2 | 501-1430 |
| | 8 | 501-1432 |
| | 8 1/2 | 501-1434 |
| | 9 | 501-1436 |

| Post Diameter A | Length L | Catalog Numbers |
|--------------------|-------------|-----------------|
| 1 3/4 (1.752) | 10 | 501-1440 |
| | 11 | 501-1444 |
| | 12 | 501-1448 |
| | 14 | 501-1456 |
| 2 (2.002) | 6 | 501-1624 |
| | 6 1/2 | 501-1626 |
| | 7 | 501-1628 |
| | 7 1/2 | 501-1630 |
| | 8 | 501-1632 |
| | 8 1/2 | 501-1634 |
| | 9 | 501-1636 |
| | 10 | 501-1640 |
| | 11 | 501-1644 |
| | 12 | 501-1648 |
| 2 1/2 (2.502) | 13 | 501-1652 |
| | 14 | 501-1656 |
| | 17 | 501-1668 |
| | 20 | 501-1680 |
| | 8 | 501-2032 |
| | 8 1/2 | 501-2034 |
| | 9 | 501-2036 |
| | 10 | 501-2040 |
| | 11 | 501-2044 |
| | 12 | 501-2048 |
| 3 (3.002) | 13 | 501-2052 |
| | 14 | 501-2056 |
| | 17 | 501-2068 |
| | 20 | 501-2080 |
| | 8 | 501-2432 |
| | 8 1/2 | 501-2434 |
| | 9 | 501-2436 |
| | 10 | 501-2440 |
| 11 | 501-2444 | |
| 12 | 501-2448 | |
| 13 | 501-2452 | |
| 14 | 501-2456 | |
| 17 | 501-2468 | |
| 20 | 501-2480 | |

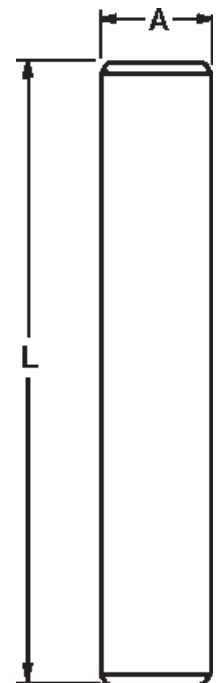

PLAIN BEARING ENGINEERING DATA



Boring Procedures and Dimensions

Holes for LEMPCO Plain Bearing Guide Posts and Bushings should be jig bored for best results. The punch holder and dieholder should be clamped together and bored in one set up to maintain dead center alignment between upper and lower bores. If this is not possible, a tolerance of $\pm .0005$ " between centers must be held. Bores should be smooth and free from tool marks to provide proper bearing area for the guide post or bushing. Dieholder bores must be perpendicular to that surface which will back up the die. The bottom surface of the die holder must be parallel to the die backup surface. The punch holder bores must be perpendicular to the surface that will back up the punches, and the top surface parallel to the punch backup surface.

Break the corners of the bored holes to a generous chamfer. On sets with a symmetrical profile one pin and bushing should be offset to prevent accidental reversing of the punch holder during assembly.

All LEMPCO Plain Bearing Guide Posts and Bushings are interchangeable without select fitting, and when mounted in accordance with the instructions and bore sizes given, do not require honing for fits except in the case of press fit mounted bushings. Please note the dimensions given in the tables. Experience proves that these are optimum dimensions and variations may cause trouble.

**BORE CHART
PLAIN BEARING COMPONENTS (INCH)**

| Nominal Guide Post Diameter | #623-SERIES DEMOUNTABLE SHORT SHOULDER BUSHING (TAP FIT) | | #624-SERIES DEMOUNTABLE SHOULDER BUSHING (TAP FIT) | |
|---------------------------------|--|--------------------|--|--------------------|
| | BORE SIZE | | BORE SIZE | |
| 1" | 1.5000 | +0.0004 -0.0000 | 1.5000 | +0.0004 -0.0000 |
| 1 ¹ / ₄ " | 1.7500 | +0.0004 -0.0000 | 1.7500 | +0.0004 -0.0000 |
| 1 ¹ / ₂ " | 2.0000 | +0.0004 -0.0000 | 2.0000 | +0.0004 -0.0000 |
| 1 ³ / ₄ " | 2.2500 | +0.0004 -0.0000 | 2.2500 | +0.0004 -0.0000 |
| 2" | 2.5000 | +0.0004 -0.0000 | 2.5000 | +0.0004 -0.0000 |
| 2 ¹ / ₂ " | 3.0000 | +0.0004 -0.0000 | 3.0000 | +0.0004 -0.0000 |
| 3" | 3.5000 | +0.0004 -0.0000 | 3.6250 | +0.0004 -0.0000 |

BORE CHART PLAIN BEARING COMPONENTS (INCH)

| Nominal Guide Post Diameter | #501-SERIES STRAIGHT GUIDE PIN (PRESS FIT) | #506-SERIES DEMOUNTABLE GUIDE PIN (TAP FIT) | #503-SERIES SHOULDER GUIDE PIN (PRESS FIT) | #601-SERIES #603-SERIES STRAIGHT STEEL SLEEVE BUSHING (PRESS FIT) | #644-SERIES #661-SERIES #662-SERIES PRESS FIT STYLE SHOULDER BUSHING (PRESS FIT) | #648-SERIES #655-SERIES #663-SERIES #664-SERIES DEMOUNTABLE STYLE SHOULDER BUSHING (TAP FIT) |
|---------------------------------|--|---|--|---|--|--|
| | BORE SIZE | BORE SIZE | BORE SIZE | BORE SIZE | BORE SIZE | BORE SIZE |
| 1/2" | .5000 +0.0006 -0.0004 | N/A | N/A | .8125 +0.0004 -0.0000 | .8125 +0.0004 -0.0000 | .8125 +0.0004 -0.0000 |
| 5/8" | .6250 +0.0006 -0.0004 | N/A | N/A | 1.0000 +0.0004 -0.0000 | 1.0000 +0.0004 -0.0000 | 1.0000 +0.0004 -0.0000 |
| 3/4" | .7500 +0.0006 -0.0004 | N/A | N/A | 1.1250 +0.0004 -0.0000 | 1.1250 +0.0004 -0.0000 | 1.1250 +0.0004 -0.0000 |
| 1" | 1.0000 +0.0006 -0.0004 | 1.0013 +0.0000 -0.0005 | BORE HOLE .0012" TO .0018" SMALLER THAN SHOULDER DIAMETER OF GUIDE PIN | 1.5000 +0.0004 -0.0000 | 1.5000 +0.0004 -0.0000 | 1.5000 +0.0004 -0.0000 |
| 1 ¹ / ₄ " | 1.2500 +0.0006 -0.0004 | 1.2513 +0.0000 -0.0005 | | 1.7500 +0.0004 -0.0000 | 1.7500 +0.0004 -0.0000 | 1.7500 +0.0004 -0.0000 |
| 1 ¹ / ₂ " | 1.5000 +0.0006 -0.0004 | 1.5013 +0.0000 -0.0005 | | 2.0000 +0.0004 -0.0000 | 2.0000 +0.0004 -0.0000 | 2.0000 +0.0004 -0.0000 |
| 1 ³ / ₄ " | 1.7500 +0.0006 -0.0004 | 1.7513 +0.0000 -0.0005 | BORE HOLE .0015" TO .0022" SMALLER THAN SHOULDER DIAMETER OF GUIDE PIN | 2.2500 +0.0004 -0.0000 | 2.2500 +0.0004 -0.0000 | 2.2500 +0.0004 -0.0000 |
| 2" | 2.0000 +0.0006 -0.0004 | 2.0013 +0.0000 -0.0005 | | 2.5000 +0.0004 -0.0000 | 2.5000 +0.0004 -0.0000 | 2.5000 +0.0004 -0.0000 |
| 2 ¹ / ₂ " | 2.5000 +0.0006 -0.0004 | 2.5013 +0.0000 -0.0005 | | 3.2500 +0.0004 -0.0000 | 3.2500 +0.0004 -0.0000 | 3.2500 +0.0004 -0.0000 |
| 3" | 3.0000 +0.0006 -0.0004 | 3.0013 +0.0000 -0.0005 | N/A | N/A | 3.7500 +0.0004 -0.0000 | 3.7500 +0.0004 -0.0000 |

The LEMPCO Value Proposition

- **LEMPCO** is a recognized leader in providing quality ball bearing components:
 1. Rotainer® designed ball cage that minimizes tracking.
 2. Precision Rotainer® and retainer that provides accuracy and repeatability in high speed applications.
 3. Quality pins and bushings are made from 52100 tool steel and are precision ground.
- **LEMPCO** offers high quality die sets with either ball bearing or plain bearing components. Pins and bushings are manufactured using high quality steel and are precision ground.
- **LEMPCO** has a strong distribution network with over 250 distributors located around the world to service our valued customers.
- **LEMPCO's** manufacturing capabilities allow larger size die sets to be offered (240 in. by 120 in.) and complex machining to be available with exceptional deliveries.



QUALITY ■ DEPENDABILITY ■ SERVICE

SINCE 1918

THE GLOBAL STANDARD WITH DISTRIBUTORS WORLDWIDE

Quality, precision and dependability
are the requirements of today's production processes—
from ultra-high-speed stamping technology
to computer-driven CNC manufacturing.

LEMPCO designs its components in order to provide you with precision and cost-effective performance... run after run. We have the proven experience in the selection of metals, developing designs and understanding the details of your needs.

**LEMPCO KNOWS WHAT IT TAKES TO KEEP YOUR DIES RUNNING
AND WE KNOW HOW TO DELIVER IT.**

Die Set Components – INCH –

Distributed by:

Please Order From:

Clark & Osborne, LLP
6617 Ferguson Avenue
Indianapolis, IN 46220

317-255-5668 Phone

317-253-4486 FAX

sales@clarkandosborne.com

LEMPCO[®]

**SERVICING
INDUSTRY
SINCE 1918**



The Anchor Danly Company

© 2006 LEMPCO. All rights reserved.

L-1005-1 09/06