

***Precision
Linear Motion
Components***

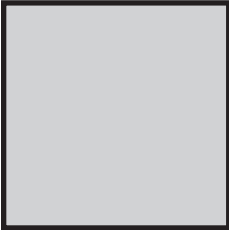

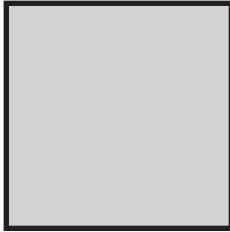
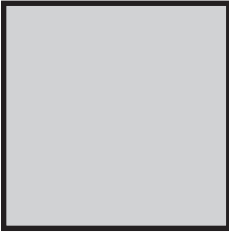

Overview

For almost fifty years, LEE LINEAR® has been committed to supplying the world with the finest precision linear motion components. To accomplish this goal, LEE LINEAR® provides:

High Quality Products

Through hard work and dedication, we have determined how to manufacture the highest quality products in the business. Our quality control program ensures each component meets or exceeds the industry standards.

Immediate Availability

The many years of experience have taught us to anticipate the sizes and types of products that are the most widely used. We keep an extensive inventory of components on hand so we can rapidly respond to customer requests.

Quick Quotes

Waiting for a quote is never a problem when calling LEE. All sales representatives are eager to answer any questions and will quickly provide a detailed quotation.

Ease of Relationship

Dealing with LEE LINEAR® is easy! From the first inquiry all the way through to order entry and delivery, LEE will be partnered with you each step of the way. We want your interactions with every LEE representative to provide satisfaction, peace of mind, and confidence in choosing us as your linear motion supplier.

Just-In-Time (JIT) Delivery

At LEE, we understand time is money. Whether you order in-stock products or custom-machined components, we will make every effort to meet your requirements.

Low Cost

We want to be the supplier of choice for linear motion components. To that end, LEE pricing is the most competitive in the industry. Our customers can be confident in our ability to provide the highest quality products at the lowest possible cost.

Lee Linear is Committed to Work Smarter to Become the Supplier of Choice for Precision Linear Motion Products!

Table of Contents

OVERVIEW	2
SHAFTING.....	4
60 Plus®	4
Ready Shafts™	4
440C Stainless	5
Pre-Drilled Shafting.....	6
Specials.....	7
SHAFT SUPPORTS.....	8
“SR” Type	8
“LSR” Type	10
“LSG”	10
Intermittent SR/LSR Type	12
“SB” Type	13
SHAFT RAIL ASSEMBLIES	14
LINEAR BALL BEARINGS	16
Precision Plus Linear Pillow Blocks	16
Precision Plus Linear Ball Bearings	17
Precision Linear Ball Bearings	18
Composite Linear Bearings	19
Composite Linear Pillow Blocks	20
Composite Linear Twin Pillow Blocks	21
Roller Bearing Pillow Blocks	23
Single Pillow Blocks	23
Double Pillow Blocks.....	25
Twin Pillow Blocks.....	26
Technical Information	26
Options.....	27
Cross Reference Guide	29
SHAFT AND RAIL SYSTEMS.....	30
System 1	30
System 2	32
SLIDE SYSTEMS	33
Basic Slides.....	34
Full Slides	36
ACCESSORIES.....	38
Carriage Plates	38
Shaft End Stops.....	38
Bellows.....	38
Linear Carriage Lock	39
Motor Mounting Blocks (NEMA Mounts)	39



SHAFTING

60 Plus®

60 Plus® Precision Linear Shafting provides the highest machineability of case hardened and ground steel shafting. Manufactured from C1060 carbon steel, **60 Plus®** is available in inch and metric sizes with lengths up to 180". Custom machining and chrome plating can be special ordered.

Standard Specifications

Surface Finish: Between 8 to 15 micro inches Ra

Stock Lengths: 8 to 15 feet

Chamfered Ends: All ends chamfered

Straightness: 0.001" to 0.002" per foot cumulative, except for 3/8" diameters and less

Length Tolerances:

±1/32" for ¼ to 1-1/4 Nom. Dia.

±1/16" for 1-3/8" to 2" Nom. Dia.

±1/8" for 2-1/2" to 3" Nom. Dia.

Hard Chrome Plating – Stainless Alternative

- Enhanced corrosion resistance
- Improved appearance
- Replacement for stainless shafting
- Longer shaft life
- Pre-plate diameter compensates for chrome thickness

SOLID 60 Plus® PRECISION CASE HARDENED & GROUND SHAFTING

HARDNESS: ROCKWELL 60 TO 65 "C"

SHAFT DIA.	TOLERANCES (Please specify tolerance code on order)					WEIGHT PER INCH (lbs.)	MINIMUM DEPTH OF HARDNESS (INCHES)	*MAXIMUM LENGTH
	CODE "A"	CODE "B"	CODE "R"	CODE "M"	g6			
1/4	0.2485/0.2490	0.2490/0.2495	0.2498/0.2500	—	0.2494/0.2499	0.014	0.040	96
3/8	0.3735/0.3740	0.3740/0.3745	0.3748/0.3750	—	0.3744/0.3748	0.031	0.040	172
1/2	0.4985/0.4990	0.4990/0.4995	0.4998/0.5000	—	0.4993/0.4998	0.055	0.060	184
5/8	0.6235/0.6240	0.6240/0.6245	0.6248/0.6250	—	0.6243/0.6248	0.086	0.060	184
3/4	0.7485/0.7490	0.7490/0.7495	0.7498/0.7500	—	0.7492/0.7497	0.125	0.060	184
7/8	—	0.8740/0.8745	0.8748/0.8750	—	—	0.170	0.060	184
1	0.9985/0.9990	0.9990/0.9995	0.9999/1.0005	1.0000/1.0003	0.9992/0.9997	0.222	0.080	196
1-1/8	—	1.1240/1.1245	1.1248/1.1250	—	—	0.281	0.080	148
1-1/4	1.2485/1.2490	1.2490/1.2495	1.2498/1.2500	1.2500/1.2503	1.2490/1.2497	0.348	0.080	184
1-3/8	—	1.3740/1.3745	1.3747/1.3750	—	—	0.420	0.080	184
1-1/2	1.4984/1.4989	1.4989/1.4994	1.4997/1.5000	1.5000/1.5003	1.4990/1.4997	0.500	0.080	184
1-3/4	—	1.7490/1.7495	1.7497/1.7500	—	—	0.681	0.100	184
2	1.9980/1.9987	1.9987/1.9994	1.9997/2.0000	2.0000/2.0003	1.9989/1.9996	0.890	0.100	184
2XL	—	1.9991/1.9994	—	—	—	0.890	0.100	184
2-1/2	2.4977/2.4985	2.4985/2.4993	2.4996/2.5000	—	—	1.391	0.100	184
3	2.9974/2.9983	2.9983/2.9992	2.9996/3.0000	—	—	2.003	0.100	148

READY SHAFTS™

When you need a shaft right away, the LEE LINEAR® READY SHAFT™ is the answer to your problem! READY SHAFTS™ are precut to a variety of factory lengths, chamfered, precision polished, and packaged in a rust inhibiting plastic sleeve. Available in high carbon 60 Plus® C1060 with a Rockwell of 60 to 65 Rc or 440C Stainless steel with a hardness of 50 to 55 Rc. These shafts are in stock and ready for immediate delivery.



TUBULAR 60 Plus® PRECISION CASE HARDENED & GROUND SHAFTING

52100 STEEL HARDNESS: ROCKWELL 60 TO 65 "C"

SHAFT DIA.	NOM. I.D. ±5%	TOLERANCES (Please specify tolerance code on order)		WEIGHT PER INCH (lbs.)	MINIMUM DEPTH OF HARDNESS (INCHES)	*MAXIMUM LENGTH
		CODE "A"	CODE "B"			
1-1/2	0.890	1.4984/1.4989	1.4989/1.4994	0.328	0.080	144
2	1.250	1.9980/1.9987	1.9987/1.9994	0.542	0.100	144

SOLID METRIC PRECISION CASE HARDENED & GROUND SHAFTING

60 Plus® - HARDNESS: ROCKWELL 60 TO 65 "C" TOLERANCE h6

440C - HARDNESS: ROCKWELL 50 TO 55 "C" TOLERANCE h6

SHAFT DIA.	METRIC TOLERANCE (INCH)	WEIGHT PER INCH (lbs.)	MINIMUM DEPTH OF HARDNESS (INCHES)	60 Plus *MAXIMUM LENGTH (INCH)	440C *MAXIMUM LENGTH (INCH)
8mm	0.3146/0.3150	0.022	0.040	172	154
12mm	0.4720/0.4724	0.050	0.060	184	154
16mm	0.6295/0.6299	0.088	0.060	184	154
20mm	0.7869/0.7874	0.138	0.060	184	154
25mm	0.9838/0.9843	0.216	0.080	196	170
30mm	1.1806/1.1811	0.311	0.080	184	118
40mm	1.5743/1.5748	0.553	0.080	184	118
50mm	1.9679/1.9685	0.864	0.100	184	154

440C Stainless

Available in inch and metric diameters, this material is corrosion resistant with a Rockwell hardness of 50/55 "C". Custom machined shafts are also available. Parts can be plated with Armoloy for higher corrosion resistance. The shafting is only available in solid and in lengths to 154".

SOLID STAINLESS STEEL PRECISION CASE HARDENED & GROUND SHAFTING

AISI 440C STEEL HARDNESS: ROCKWELL 50 TO 55 "C"

SHAFT DIA.	TOLERANCES (Please specify tolerance code on order)			WEIGHT PER INCH (lbs.)	MINIMUM DEPTH OF HARDNESS (INCHES)	*MAXIMUM LENGTH
	CODE "A"	CODE "B"	g6			
1/4	0.2485/0.2490	0.2490/0.2495	0.2494/0.2499	0.014	0.040	144
3/8	0.3735/0.3740	0.3740/0.3745	0.3744/0.3748	0.031	0.040	154
1/2	0.4985/0.4990	0.4990/0.4995	0.4993/0.4998	0.055	0.060	154
5/8	0.6235/0.6240	0.6240/0.6245	0.6243/0.6248	0.086	0.060	154
3/4	0.7485/0.7490	0.7490/0.7495	0.7492/0.7497	0.125	0.060	154
1	0.9985/0.9990	0.9990/0.9995	0.9992/0.9997	0.222	0.080	170
1-1/4	1.2485/1.2490	1.2490/1.2495	1.2490/1.2497	0.348	0.080	154
1-1/2	1.4984/1.4989	1.4989/1.4994	1.4990/1.4997	0.500	0.080	154
2	1.9980/1.9987	1.9987/1.9994	1.9989/1.9996	0.890	0.100	154

* Shafts can be joined for longer lengths. Please contact Customer Service.



Pre-Drilled Shafting

Available in 1/2" to 3" diameters, these shafts are pre-drilled with a standard industrial hole pattern to meet most applications. For longer lengths, shafts can be butt or dowel jointed.

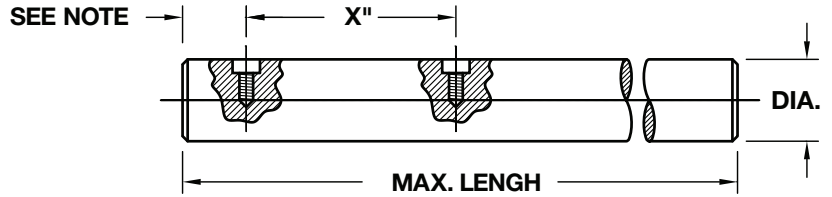

PRE-DRILLED SHAFTING

SOLID 60 Plus® & 440C STAINLESS STEEL

SHAFT DIA.	DIAMETER TOLERANCE	MAXIMUM LENGTH	"X" HOLE SPACING ±.015" (NON-CUMULATIVE)	TAP SIZE (TO CENTER OF SHAFT)	MAXIMUM LENGTH		
					60 PLUS	440C	TUBULAR
1/2 PD	0.4990/0.4995	144±1/32	4	6-32	181	151	–
5/8 PD	0.6240/0.6245	144±1/32	4	8-32	181	151	–
3/4 PD	0.7490/0.7495	144±1/32	6	10-32	181	151	–
1 PD	0.9990/0.9995	144±1/32	6	1/4-20	193	151	–
1-1/4 PD	1.2490/1.2495	144±1/16	6	5/16-18	181	151	–
1-1/2 PD	1.4989/1.4994	132±1/16	8	3/8-16	181	151	144
2 PD	1.9987/1.9994	132±1/16	8	1/2-13	181	151	144
3 PD	2.9983/2.9992	132±1/16	8	3/4-10	132	–	–

For pre-drilled longer lengths, please contact the factory.

3" PD is not available in 440C stainless.

Note:

The standard "Y" dimension of in-stock shafts is 1/2 of the "X" dimension, but different first-hole locations can be specified when ordering, providing the location is not more than the "X" hole spacing. Holes are drilled and tapped to center of shaft.

METRIC PRE-DRILLED SHAFTING

SOLID 60 Plus®

DIAMETER TOL h6	TAP SIZE	"X" SPACING		LENGTH	
		INCHES	MILLIMETERS	INCHES	MILLIMETERS
12mm	M4X0.7	2.9528	75mm	181	4597mm
16mm	M5X0.8	3.9370	100mm	181	4597mm
20mm	M6X1	3.9370	100mm	181	4597mm
25mm	M8X1.25	4.7244	120mm	193	4902mm
30mm	M10X1.5	5.9055	150mm	181	4597mm
40mm	M10X1.5	7.8740	200mm	177	4496mm
50mm	M12X1.75	7.8740	200mm	177	4496mm

Note:

The standard "Y" dimension of in-stock shafts is 1/2 of the "X" dimension, but different first-hole locations can be specified when ordering, providing the location is not more than the "X" hole spacing. Holes are drilled and tapped to center of shaft.



Specials

Custom machining capabilities include special grinds, special straightness, plating and more. Simply send your drawing(s), specifications, and the quantity needed, and we will handle the rest.

Threading

Standard threads: UNC or UNF Class 2-A

In the threaded area, the shaft will be annealed and soft.

Diameter Reduction

Normal tolerance: ± 0.005 "

Concentricity: ± 0.002 " Max. T.I.R.

Shafts turned down require annealing.

Coaxial Holes In End of Shaft

Standard threads: UNC or UNF Class 2-B

Concentricity: 0.002"

Thread depth standard: Double the diameter of the screw.

Annealing may be required on shafts where the tap size is within close proximity to the case.

Radial Holes To Center of Shaft

Standard threads: UNC or UNF Class 2-B

Shaft diameter: $\frac{1}{2}$ " to 3"

Location tolerances: ± 0.015 " standard, ± 0.010 " or ± 0.005 " custom

Radial Holes Drilled and/or Tapped Through Shaft

Shaft diameter: $\frac{1}{2}$ " to 3"

Location tolerance: ± 0.010 "

In most cases, annealing is not necessary for holes drilled through and/or counterbored.

Shafts Joined for Longer Lengths

Shaft diameter: $\frac{5}{8}$ " to 3"

Concentricity: 0.002"

Ends: Machined square without chamfer

Shafts can be butt or dowel jointed for longer lengths.

Retaining Ring Groove

Location tolerance: ± 0.062 " standard, ± 0.005 " custom

It is standard practice to anneal the shaft to soften the area of the groove. If this is not desired, please contact us for alternate methods.

Keyways

Standard shapes: Square or American Standard Woodruff

Annealing is performed to soften the circumference area around the keyway.

Flats

Location tolerance: ± 0.015 "

Multiple flats are acceptable. Please contact the factory with other requests.

Gun/Deep Hole Drilling

This drilling technique should be used only in applications where concentricity is not critical. The maximum size of a hole produced by this method is limited by the depth of the case hardening.



SHAFT SUPPORTS

For effective, low-cost continuous or intermittent support, LEE LINEAR® extruded aluminum support rails are available in a full range of sizes to accommodate shafts up to 3" diameter (see specification chart below). These rails can be supplied with or without mounting holes, and can be used vertically or horizontally to provide optimum rigidity. Available in standard lengths of 24" and 48" + 0", - 1/8".

"SR" Type

The LEE LINEAR® extruded aluminum "SR" type support rails have been designed with a notch along the bottom. This notch allows for even cooling during the extrusion process, which decreases warp and twist in the final product. Not only does this notch improve quality, it also decreases the shaft support cost by eliminating the machining of the bottom-counterbored holes. Effective for vertical or horizontal applications, the "SR" type supports come in 24" and 48", +0", -1/8" standard lengths. Cutting is available on all sizes. Support Rails can be ordered pre-drilled, without machining, or drilled to special requirements.

TYPE SR EXTRUDED ALUMINUM SUPPORT RAILS

PART NO.	NOM. SHAFT DIA.	A ±.002	B	C	D	WT. PER 24" (LBS)
SR-8	1/2	1.125	1-1/2	1/4	3/16	1.200
SR-10	5/8	1.125	1-5/8	5/16	1/4	1.500
SR-12	3/4	1.500	1-3/4	3/8	1/4	2.000
SR-16	1	1.750	2-1/8	1/2	1/4	2.600
SR-20	1-1/4	2.125	2-1/2	9/16	5/16	3.500
SR-24	1-1/2	2.500	3	11/16	3/8	5.100
SR-32	2	3.250	3-3/4	7/8	1/2	8.200
SR-48	3	4.000	6	1-3/8	3/4	15.300

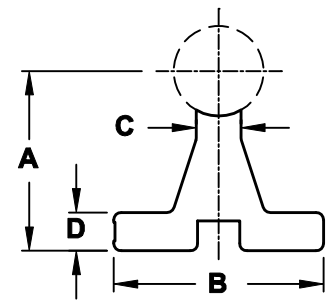

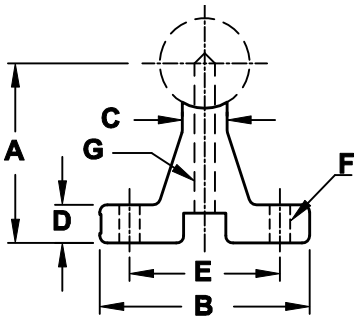

TYPE SR-PD SERIES EXTRUDED ALUMINUM SUPPORT RAILS WITH PRE-DRILLED HOLES TO MATE WITH TYPE PD SHAFTS

PART NO.	SHAFT DIA.	A ±.002	B	C	D	E	F		G		WT. PER 24" (LBS)
							BOLT	HOLE	BOLT	HOLE	
SR-8-PD	1/2	1.125	1-1/2	1/4	3/16	1	#6	0.169	6-32X7/8	0.169	1.200
SR-10-PD	5/8	1.125	1-5/8	5/16	1/4	1-1/8	#8	0.193	8-32X7/8	0.193	1.500
SR-12-PD	3/4	1.500	1-3/4	3/8	1/4	1-1/4	#10	0.221	10-32X1-1/4	0.221	2.000
SR-16-PD	1	1.750	2-1/8	1/2	1/4	1-1/2	1/4	0.281	1/4-20X1-1/2	0.281	2.600
SR-20-PD	1-1/4	2.125	2-1/2	9/16	5/16	1-7/8	5/16	0.343	5/16-18X1-3/4	0.343	3.500
SR-24-PD	1-1/2	2.500	3	11/16	3/8	2-1/4	5/16	0.343	3/8-16X2	0.406	5.100
SR-32-PD	2	3.250	3-3/4	7/8	1/2	2-3/4	3/8	0.406	1/2-13X2-1/2	0.531	8.200
SR-48-PD	3	4.000	6	1-3/8	3/4	4-1/4	5/8	0.656	3/4-10X3-1/4	0.718	15.300

Note:
Pre-drilled support rails are stocked for immediate delivery in standard 24" and 48" lengths, and can be cut to size. When longer shafts are to be supported, the rails can be continuously mounted end-to-end or intermittently mounted.

MOUNTING HOLE PATTERNS

Various patterns are shown below. The alignment and location of holes are ± .015 non-cumulative.

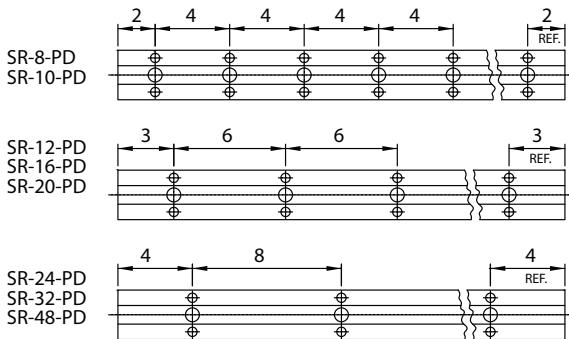

HOW TO ORDER

When ordering standard support rails with mounting holes, order by part number (for example, SR-20-PD, 48"). If a shorter length is required, specify part number and exact length. For example, SR-20-PD, 18" long.

LEE LINEAR® can supply shafts and rails as complete assemblies in any length. When ordering, please specify the shaft diameter and overall length. We will assemble using standard pre-drilled shafts and support rails. (See page 6). For hole spacing other than standard patterns shown, please provide drawings with request for quotation.



“LSR”

The AISI C-1018 steel “LSR” shaft support is a low support rail with a reduced footprint, and 40% lower profile. This is an excellent choice for applications requiring compact low shaft support. The standard length for “LSR” type supports is 48". Special lengths can be accommodated. Length tolerance +0", -1/8".

TYPE LSR LOW SUPPORT RAILS

PART NO.	SHAFT DIA.	A ±.002	B ±.005	C (REF)	D		HOLE SPACING FOR LSR-PD		APPROX. WT. IN LBS. PER 48"
					BOLT	HOLE	Y	X	
LSR-8 LSR-8-PD	1/2	0.562	0.370	0.341	6-32	0.169	2	4	1.320
LSR-10 LSR-10-PD	5/8	0.687	0.450	0.412	8-32	0.193	2	4	1.950
LSR-12 LSR-12-PD	3/4	0.750	0.510	0.420	10-32	0.221	3	6	2.250
LSR-16 LSR-16-PD	1	1.000	0.690	0.560	1/4-20	0.281	3	6	4.250
LSR-20 LSR-20-PD	1-1/4	1.187	0.780	0.626	5/16-18	0.343	3	6	5.080
LSR-24 LSR-24-PD	1-1/2	1.375	0.930	0.703	3/8-16	0.406	4	8	6.720
LSR-32 LSR-32-PD	2	1.750	1.180	0.845	1/2-13	0.531	4	8	11.000
LSR-48 LSR-48-PD	3	2.750	1.875	1.404	3/4-10	0.812	4	8	27.920

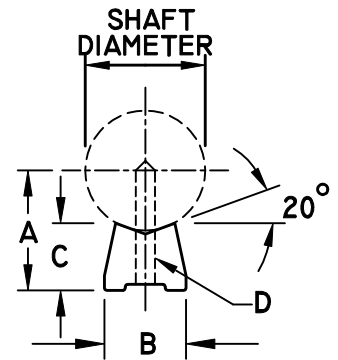

Material: C1018 Carbon Steel

LOW SUPPORT GUIDES

The LEE LINEAR® Low Shaft Guide is a 60 Plus® precision case hardened and ground shaft, and an LSR steel support rail. This guide effectively doubles the life of the shaft by allowing it to be turned over for a fresh surface when wear becomes evident. Both sides of the shaft are counterbored so the shaft may be rotated 180°, and rebolted for use on the new side. This guide is sold as a two piece set; the shaft and support are not assembled. The guide is then bolted down through the top of the shaft to reduce installation time. The shafts are also available in 440C stainless steel. Drilled through and counterbored shafts may not be suitable for all linear bearings.

PART NO.	SHAFT DIA.	H	B	X	N	WEIGHT PER INCH
LSG-10	5/8	0.687	0.450	2	#5	0.132
LSG-12	3/4	0.750	0.510	3	#6	0.171
LSG-16	1	1.000	0.690	3	#10	0.311
LSG-20	1-1/4	1.187	0.780	3	5/16	0.454
LSG-24	1-1/2	1.375	0.930	4	3/8	0.640
LSG-32	2	1.750	1.180	4	1/2	1.119

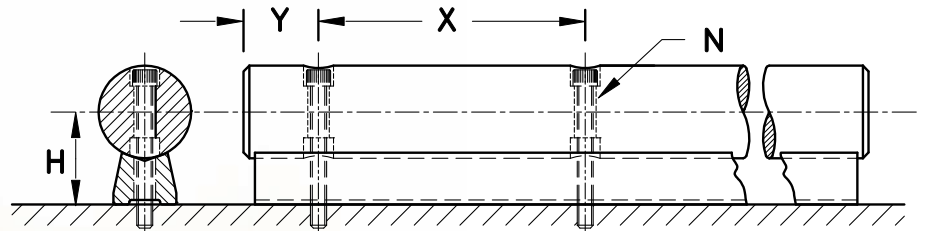

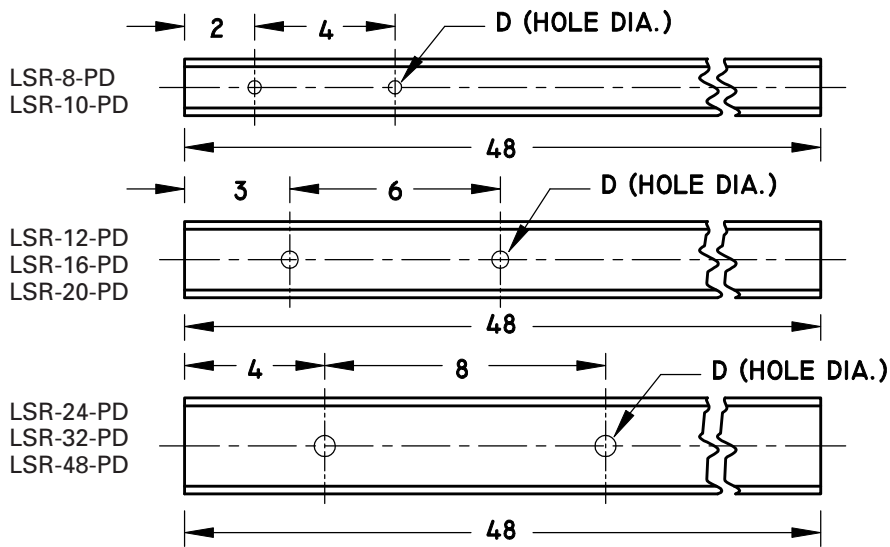

HOW TO ORDER

When ordering standard 48" long low shaft rails without mounting holes, order by part number. For example, LSR-12.

If standard mounting holes are required, specify low shaft rails with pre-drilled mounting holes by part number. For example, LSR-12-PD hole sizes and spacings are shown in the table.

If other than standard hole spacing is required, please provide drawings with all dimensions, tolerances and quantity.

With or without mounting holes, low shaft rails will be supplied in 48" lengths when ordered by part number. Special lengths can be provided.



Intermittent SR/LSR Type

LEE LINEAR® offers "SRI" and "LSRI" intermittent type rails for applications when constant support is not required. "SRI" type rails are used to support standard shaft sizes, while "LSRI" rails are used to support shafts of low height. Both the "SRI" and the "LSRI" rails are available in two lengths to meet various design requirements. Length tolerance +0", -1/8".

INTERMITTENT SUPPORT RAILS #SRI 1

The SRI 1 rails are for those applications not requiring continuous support.

PART NO.	SHAFT DIA.	A ±.002	B	C	D	E	F	G	Y	L
SRI 1-08	1/2	1.125	1.500	0.250	0.187	1.000	#6	6-32	1	2
SRI 1-10	5/8	1.125	1.625	0.312	0.250	1.125	#8	8-32	1	2
SRI 1-12	3/4	1.500	1.750	0.375	0.250	1.250	#10	10-32	1-1/2	3
SRI 1-16	1	1.750	2.125	0.500	0.250	1.500	1/4	1/4-20	1-1/2	3
SRI 1-20	1-1/4	2.125	2.500	0.562	0.312	1.875	5/16	5/16-18	1-1/2	3
SRI 1-24	1-1/2	2.500	3.000	0.687	0.375	2.250	5/16	3/8-16	2	4
SRI 1-32	2	3.250	3.750	0.875	0.500	2.750	3/8	1/2-13	2	4
SRI 1-48	3	4.000	6.000	1.437	0.750	4.250	5/8	3/4-10	2	4

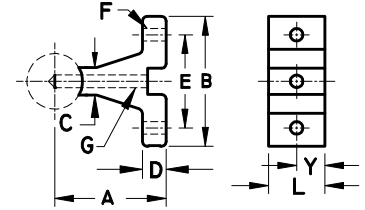

SRI 1 SERIES

INTERMITTENT SUPPORT RAILS #SRI 2

The SRI 2 intermittent rails are ideal for support below joint support.

PART NO.	SHAFT DIA.	A ±.002	B	C	D	E	F	G	Y	X	L
SRI 2-08	1/2	1.125	1.500	0.250	0.187	1.000	#6	6-32	1	4	6
SRI 2-10	5/8	1.125	1.625	0.312	0.250	1.125	#8	8-32	1	4	6
SRI 2-12	3/4	1.500	1.750	0.375	0.250	1.250	#10	10-32	1	5	8
SRI 2-16	1	1.750	2.125	0.500	0.250	1.500	1/4	1/4-20	1	5	8
SRI 2-20	1-1/4	2.125	2.500	0.562	0.312	1.875	5/16	5/16-18	1	5	8
SRI 2-24	1-1/2	2.500	3.000	0.687	0.375	2.250	5/16	3/8-16	1-1/2	8	11
SRI 2-32	2	3.250	3.750	0.875	0.500	2.750	3/8	1/2-13	1-1/2	8	11
SRI 2-48	3	4.000	6.000	1.437	0.750	4.250	5/8	3/4-10	1-1/2	8	11

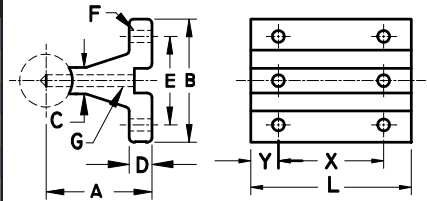

SRI 2 SERIES

INTERMITTENT LOW SHAFT SUPPORT RAILS #LSRI 1

The LSRI 1 rails are for those applications not requiring continuous support.

PART NO.	SHAFT DIA.	A	B	C	D		Y	L
					BOLT	HOLE		
LSRI 1-08	1/2	0.562	0.370	0.341	6-32	0.169	1	2
LSRI 1-10	5/8	0.687	0.450	0.412	8-32	0.193	1	2
LSRI 1-12	3/4	0.750	0.510	0.420	10-32	0.221	1-1/2	3
LSRI 1-16	1	1.000	0.690	0.560	1/4-20	0.281	1-1/2	3
LSRI 1-20	1-1/4	1.187	0.780	0.626	5/16-18	0.343	1-1/2	3
LSRI 1-24	1-1/2	1.375	0.930	0.703	3/8-16	0.406	2	4
LSRI 1-32	2	1.750	1.180	0.845	1/2-13	0.531	2	4
LSRI 1-48	3	2.750	1.875	1.404	3/4-10	0.812	2	4

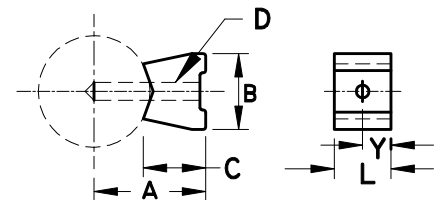

LSRI 1 SERIES



INTERMITTENT LOW SHAFT SUPPORT RAILS #LSRI 2

The LSRI 2 intermittent rails are ideal for below joint support.

PART NO.	SHAFT DIA.	A	B	C	D		Y	X	L
					BOLT	HOLE			
LSRI 2-08	1/2	0.562	0.370	0.341	6-32	0.169	1	4	6
LSRI 2-10	5/8	0.687	0.450	0.412	8-32	0.193	1	4	6
LSRI 2-12	3/4	0.750	0.510	0.420	10-32	0.221	1	6	8
LSRI 2-16	1	1.000	0.690	0.560	1/4-20	0.281	1	6	8
LSRI 2-20	1-1/4	1.187	0.780	0.626	5/16-18	0.343	1	6	8
LSRI 2-24	1-1/2	1.375	0.930	0.703	3/8-16	0.406	1-1/2	8	11
LSRI 2-32	2	1.750	1.180	0.845	1/2-13	0.531	1-1/2	8	11
LSRI 2-48	3	2.750	1.875	1.404	3/4-10	0.812	1-1/2	8	11

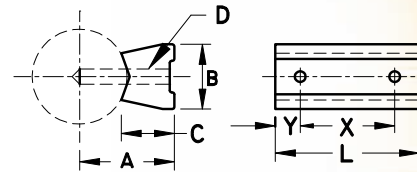

LSRI 2 SERIES

The length tolerance of intermittent support rails is $\pm 0.000/-0.125$ "

"SB" Type

Shaft support blocks provide a means of supporting shafts without the need to machine hardened shafting. Support blocks are primarily intended for applications where loading is relatively light, and the resulting deflection between supports does not create a problem that would hinder the bearing and reduce its travel life.

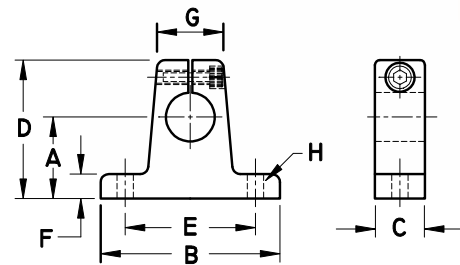

PART NO.	SHAFT DIA.	A ± 0.002	B	C	D	E ± 0.005	F	G	H		WT. (LBS)
									BOLT	HOLE	
SB-8	1/2	1.000	2.000	0.625	1.625	1.500	0.250	0.750	#10	7/32	0.270
SB-10	5/8	1.000	2.500	0.750	1.750	1.875	0.312	0.875	#10	7/32	0.400
SB-12	3/4	1.250	2.750	0.750	2.125	2.000	0.375	1.000	1/4	9/32	0.520
SB-16	1	1.500	3.312	1.000	2.625	2.500	0.375	1.375	1/4	9/32	1.110
SB-20	1-1/4	1.750	4.000	1.250	3.000	3.000	0.437	1.750	5/16	11/32	1.910
SB-24	1-1/2	2.000	4.750	1.250	3.500	3.500	0.500	2.000	5/16	11/32	2.520
SB-32	2	2.500	6.000	1.500	4.500	4.500	0.625	2.625	3/8	13/32	5.100

Material: C1040 Carbon Steel



SHAFT RAIL ASSEMBLIES

Comprised of aluminum shaft support rails and case hardened and precision ground 60 Plus® or 440C shafting, LEE LINEAR® Shaft Rail Assemblies exhibit exceptional qualities. Support rails are manufactured in 24" and 48" lengths. Longer lengths of shafting require the use of multiple rails. Standard pre-drilled hole patterns will correspond to a particular diameter.

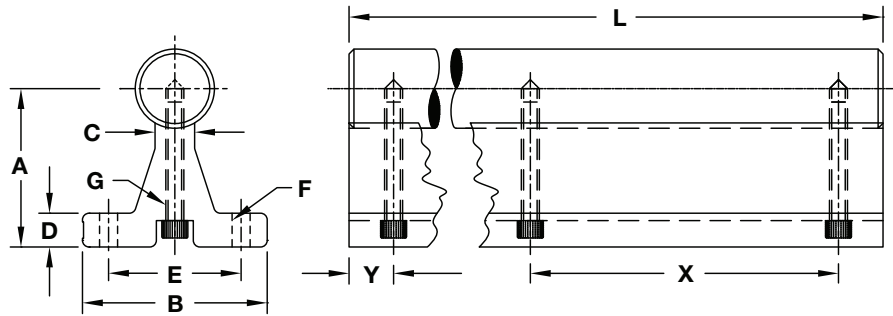

Assembled from standard pre-drilled material

Shafting can be provided in 60 Plus® or 440C. Support rails are manufactured in standard 24" and 48" lengths, longer lengths of shafting require the use of multiple rails. Standard pre-drilled hole pattern will correspond to a particular diameter.

PART NO.	SHAFT DIA.	A	B	C	D	E	F		G THD	Y	X
							BOLT	HOLE			
SA 8	1/2	1.125	1-1/2	1/4	3/16	1	#6	0.169	6-32	2	4
SA 10	5/8	1.125	1-5/8	5/16	1/4	1-1/8	#8	0.193	8-32	2	4
SA 12	3/4	1.500	1-3/4	3/8	1/4	1-1/4	#10	0.221	10-32	3	6
SA 16	1	1.750	2-1/8	1/2	1/4	1-1/2	1/4	0.281	1/4-20	3	6
SA 20	1-1/4	2.125	2-1/2	9/16	5/16	1-7/8	5/16	0.343	5/16-18	3	6
SA 24	1-1/2	2.500	3	11/16	3/8	2-1/4	5/16	0.343	3/8-16	4	8
SA 32	2	3.250	3-3/4	7/8	1/2	2-3/4	3/8	0.406	1/2-13	4	8
SA 48	3	4.000	6	1-3/8	3/4	4-1/4	5/8	0.656	3/4-10	4	8

Standard "Y" dimension of in-stock shafts and rails is 1/2 of the "X" dimension. Different first hole locations may be specified, providing that they do not exceed the "X" dimension.

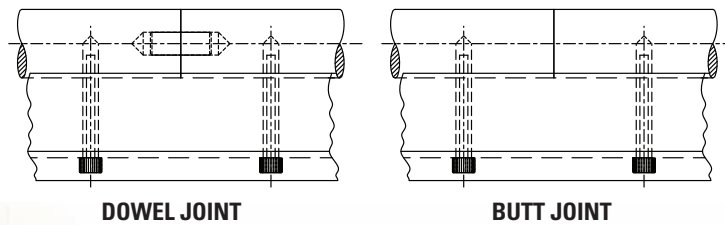

Assembly shafts can be doweled with a concentricity of .002" or can have butted ends to obtain longer lengths. In each case, the mating ends are machined square. There is no chamfer.



SHAFT DEFLECTION

Shaft deflection will affect the system performance. Use the following equation to calculate the maximum shaft deflection (in the center) of a system using 60 Plus® shafting and end supports.

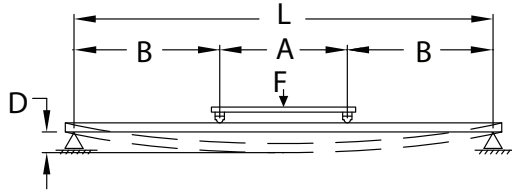

$$D = \frac{F \times B \times [3L^2 - 4B^2]}{48EI} + \frac{5SL^4}{384EI}$$

D = Deflection (in)
 L = Distance between the shaft support (in)
 E = Modulus of Elasticity (lbf/in²) (30 x 10⁶)
 I = Shafts Moment of inertia (in⁴)
 S = Shaft unit weight (lbf/in)
 F = Load (including carriage weight) (lbf)
 A = Distance between the carriage bearings (in)
 B = (L - A)/2 (in)

VALUES FOR 60 PLUS® LINEAR SHAFING								
SOLID SHAFT			TUBULAR SHAFT			METRIC SHAFT		
SHAFT DIA.	EI (lbf/in ²)	S (lbf/in)	SHAFT DIAMETER (INCHES)	EI (lbf/in ²)	S (lbf/in)	SHAFT DIAMETER (INCHES)	EI (lbf/in ²)	S (lbf/in)
1/4	5.75x10 ³	0.014	—	—	—	8	1.45x10 ⁴	0.022
3/8	2.91x10 ⁴	0.031	—	—	—	12	7.34x10 ⁴	0.050
1/2	9.20x10 ⁴	0.055	—	—	—	16	2.32x10 ⁵	0.088
5/8	2.25x10 ⁵	0.086	—	—	—	20	5.66x10 ⁵	0.138
3/4	4.66x10 ⁵	0.125	—	—	—	25	1.38x10 ⁶	0.216
7/8	8.63x10 ⁵	0.170	—	—	—	30	2.87x10 ⁶	0.311
1	1.47x10 ⁶	0.222	—	—	—	40	9.06x10 ⁶	0.552
1-1/8	2.36x10 ⁶	0.281	—	—	—	50	2.21x10 ⁷	0.863
1-1/4	3.60x10 ⁶	0.348	—	—	—	—	—	—
1-3/8	5.26x10 ⁶	0.420	—	—	—	—	—	—
1-1/2	7.46x10 ⁶	0.500	1-1/2	6.53x10 ⁶	0.325	—	—	—
1-3/4	1.38x10 ⁷	0.681	—	—	—	—	—	—
2	2.36x10 ⁷	0.890	2	2.00x10 ⁷	0.543	—	—	—
3	1.19x10 ⁸	2.003	—	—	—	—	—	—

Notes:

For shaft deflection of a system using a single pillow block with no carriage, use the above equation with A = 0.

For shaft deflection of systems using double or twin roller bearing pillow blocks with no carriage, use the above equation with A = Distance between the pillow block rollers (See tables).



LINEAR BALL BEARINGS PRECISION PLUS LINEAR PILLOW BLOCKS

LEE LINEAR® Precision Plus Linear Pillow Blocks offer all the advantages of bearings in a complete pillow block.

CLOSED PILLOW BLOCKS-SPB_B

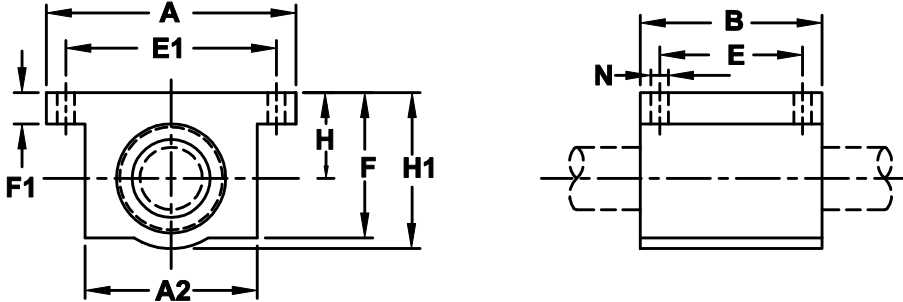

PART NUMBER	SHAFT DIA.	H ±.003	H1	A	A2	B	E ±.010	E1 ±.010	F	F1	N		MASS (b)	LOAD RATING (lbf)
											HOLE	BOLT		
SPB08B	1/2	0.687	1.250	2.000	1.380	1.690	1.000	1.688	1.130	0.250	0.160	#6	0.200	255
SPB10B	5/8	0.875	1.630	2.500	1.750	1.940	1.125	2.125	1.440	0.280	0.190	#8	0.500	450
SPB12B	3/4	0.937	1.750	2.750	1.880	2.060	1.250	2.375	1.560	0.310	0.190	#8	0.600	600
SPB16B	1	1.187	2.190	3.250	2.380	2.810	1.750	2.875	1.940	0.380	0.220	#10	1.200	1050
SPB20B	1-1/4	1.500	2.810	4.000	3.000	3.630	2.000	3.500	2.500	0.440	0.220	#10	2.500	1500
SPB24B	1-1/2	1.750	3.250	4.750	3.500	4.000	2.500	4.125	2.880	0.500	0.280	1/4	3.800	2000

OPEN PILLOW BLOCKS-SPB_OPB

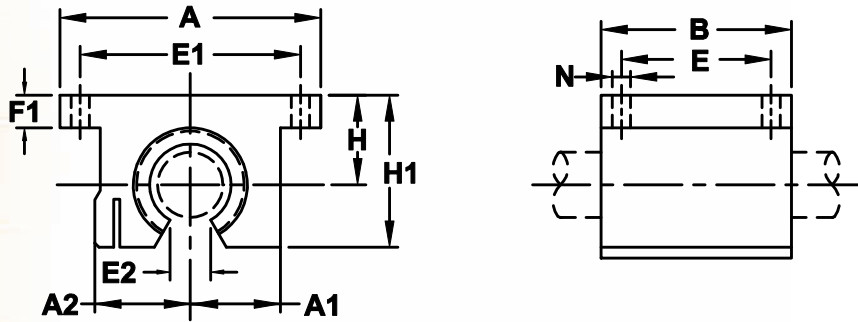

PART NUMBER	SHAFT DIA.	H ±.003	H1	A	A1	A2	B	E ±.010	E1 ±.010	E2	F1	N		MASS (b)	LOAD RATING (lbf)
												HOLE	BOLT		
SPB08OPB	1/2	0.687	1.130	2.000	0.690	0.750	1.500	1.000	1.688	0.310	0.250	0.160	#6	0.200	230
SPB10OPB	5/8	0.875	1.440	2.500	0.880	0.940	1.750	1.125	2.125	0.370	0.280	0.190	#8	0.400	320
SPB12OPB	3/4	0.937	1.560	2.750	0.940	1.000	1.880	1.250	2.375	0.430	0.310	0.190	#8	0.500	470
SPB16OPB	1	1.187	2.000	3.250	1.190	1.250	2.630	1.750	2.875	0.560	0.380	0.220	#10	1.000	780
SPB20OPB	1-1/4	1.500	2.560	4.000	1.500	1.630	3.380	2.000	3.500	0.620	0.440	0.220	#10	2.100	1170
SPB24OPB	1-1/2	1.750	2.940	4.750	1.750	1.880	3.750	2.500	4.125	0.750	0.500	0.280	1/4	3.200	1560



PRECISION PLUS LINEAR BALL BEARINGS

To compensate for misalignment, LEE LINEAR® Precision Plus Linear Ball Bearings are self aligning. Available in open or closed configuration with integral seals, LEE LINEAR® Precision Plus Linear Ball Bearings come with, or without the pillow block housing.

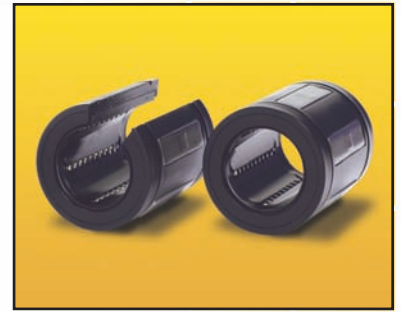

CLOSED BEARINGS-SU_B

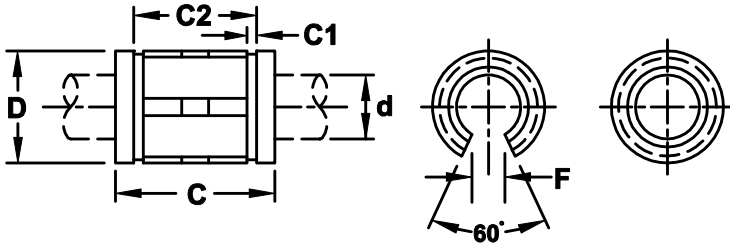

PART NUMBER	SHAFT DIA. d	NUMBER OF BALL CIRCUITS	HOUSING BORE DIA. D	C	C2	C1	MAXIMUM LOAD CAPACITY (lbf)
SU06B	3/8	4	0.6250/0.6255	0.875/0.860	0.689/0.699	0.039	105
SU08B	1/2	4	0.8750/0.8755	1.250/1.230	1.012/1.032	0.050	265
SU10B	5/8	5	1.1250/1.1255	1.500/1.480	1.095/1.105	0.056	420
SU12B	3/4	6	1.2500/1.2505	1.625/1.605	1.250/1.270	0.056	640
SU16B	1	6	1.5625/1.5630	2.250/2.230	1.864/1.884	0.068	1045
SU20B	1-1/4	6	2.0000/2.0008	2.625/2.600	1.984/2.004	0.068	1585
SU24B	1-1/2	6	2.3750/2.3760	3.000/2.970	2.390/2.410	0.086	1930

OPEN BEARINGS-SU_OPB

PART NUMBER	NOMINAL SHAFT DIA. d	NUMBER OF BALL CIRCUITS	HOUSING BORE DIA. D	C	B	C2	C1	MAXIMUM LOAD CAPACITY (lbf)	F
SU080PB	1/2	4	0.8755/0.8750	1.250/1.230	0.320	1.032/1.012	0.050	265	0.320
SU100PB	5/8	5	1.1255/1.1250	1.500/1.480	0.380	1.105/1.095	0.056	420	0.380
SU120PB	3/4	6	1.2505/1.2500	1.625/1.605	0.430	1.270/1.250	0.056	640	0.430
SU160PB	1	6	1.5630/1.5625	2.250/2.230	0.560	1.884/1.864	0.068	1045	0.560
SU200PB	1-1/4	6	2.0008/2.0000	2.625/2.600	0.630	2.004/1.984	0.068	1585	0.630
SU240PB	1-1/2	6	2.3760/2.3750	3.000/2.970	0.750	2.410/2.390	0.086	1930	0.750



PRECISION LINEAR BALL BEARINGS

Closed or open, sealed or not, LEE LINEAR® Precision Linear Ball Bearings are made with the same engineering expertise for which LEE is known.

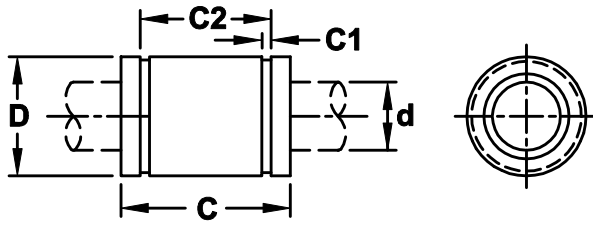

CLOSED BEARINGS

For seals add the suffix "DD"

PART NUMBER	d SHAFT DIAMETER	D OUTSIDE DIAMETER	C LENGTH	C1 RETAINING GROOVE WIDTH	C2 DISTANCE BETWEEN RETAINING GROOVES	NO. OF BALL CIRCUITS	BEARING MASS (Lb)	HOUSING BORE DIAMETER NORMAL FIT	DYNAMIC LOAD CAPACITY (Lb ')
A4812	0.2485/0.2490	0.4996/0.5000	0.750	0.039	0.499/0.515	3	0.020	0.5000/0.5005	19
A61014	0.3735/0.3740	0.6246/0.6250	0.875	0.039	0.640/0.624	4	0.060	0.6250/0.6255	36
A81420	0.4985/0.4990	0.8746/0.8750	1.250	0.046	0.951/0.967	4	0.080	0.8750/0.8755	85
A122026	0.7485/0.7490	1.2496/1.2500	1.625	0.056	1.154/1.170	5	0.210	1.2500/1.2505	200
A162536	0.9985/0.9990	1.5621/1.5625	2.250	0.068	1.741/1.759	5	0.380	1.5624/1.5630	350
A203242	1.2485/1.2490	1.9995/2.0000	2.625	0.068	1.991/2.009	6	1.100	2.0000/2.0010	520
A243848	1.4984/1.4989	2.3745/2.3750	3.000	0.086	2.397/2.415	6	1.430	2.3740/2.3760	770
A324864	1.9980/1.9987	2.9994/3.0000	4.000	0.103	3.177/3.195	6	2.750	3.0000/3.0010	1100

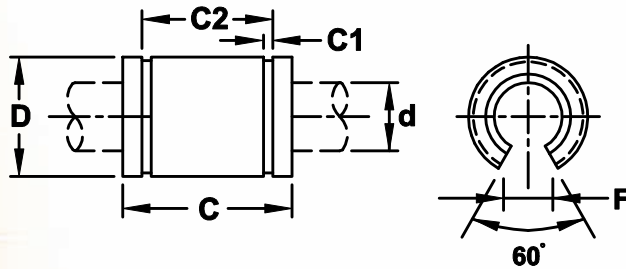

OPEN BEARINGS

For seals add the suffix "DD"

PART NUMBER	d SHAFT DIAMETER	D OUTSIDE DIAMETER	C LENGTH	C1 RETAINING GROOVE WIDTH	C2 DISTANCE BETWEEN RETAINING GROOVES	NO. OF BALL CIRCUITS	BEARING MASS (Lb)	HOUSING BORE DIAMETER NORMAL FIT	DYNAMIC LOAD CAPACITY (Lb ')
OPN81420	0.4985/0.4990	0.8746/0.8750	1.250	0.046	0.951/0.967	3	0.080	0.8750/0.8755	85
OPN122026	0.7485/0.7490	1.2496/1.2500	1.625	0.056	1.154/1.170	4	0.210	1.2500/1.2505	200
OPN162536	0.9985/0.9990	1.5621/1.5625	2.250	0.068	1.741/1.759	4	0.380	1.5624/1.5630	350
OPN203242	1.2485/1.2490	1.9995/2.0000	2.625	0.068	1.991/2.009	5	1.100	2.0000/2.0010	520
OPN243848	1.4984/1.4989	2.3745/2.3750	3.000	0.086	2.397/2.415	5	1.430	2.3740/2.3760	770
OPN324864	1.9980/1.9987	2.9994/3.0000	4.000	0.103	3.177/3.195	5	2.750	3.0000/3.0010	1100



COMPOSITE LINEAR BEARINGS

LEE LINEAR® composite bearings are offered in Self Lubricated and Ceramic composites, in sleeve bearings and pillow block models. The Self Lubricating bearing is manufactured with Teflon® and polyimide filler, while the Ceramic bearing is a ceramic coating over an aluminum shell. These bearings offer high load capabilities with low friction. Self Lubricated Bearings require no lubrication while the Ceramic bearing requires a lubricant (no silicone). These composite bearings have a 5000 PSI rating.

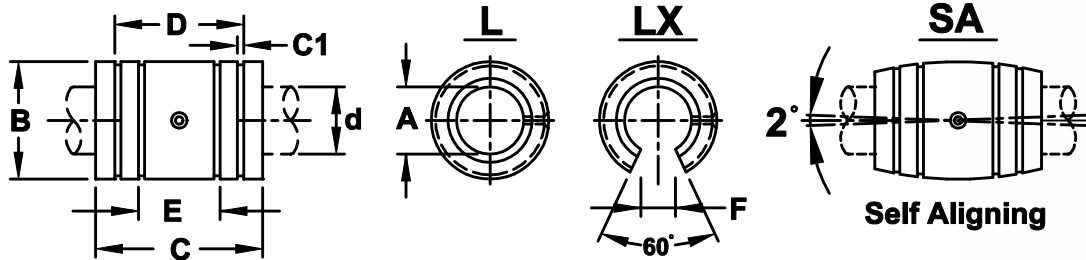

INCH SERIES

Available in Ceramic or Self Lubricating styles

BEARING NUMBER (L OR LX)	WORKING BORE		OUTSIDE DIAMETER		LENGTH		DISTANCE BETWEEN RETAINING RINGS D	DISTANCE BETWEEN O-RING GROOVES E	SLOT WIDTH +.020 -0.000 F	RETAINING HOLE DIAMETER H
	INCHES A	TOL. -0.000 +	INCHES B	TOL. +0.000 -	INCHES C	TOL. +.000 -				
408-6	0.2505	0.0010	0.5000	0.0010	0.750	0.015	0.437	0.018	0.094	0.094
610-7	0.3755	0.0010	0.6250	0.0010	0.875	0.015	0.562	0.260	0.156	0.094
610-7SU	0.3755	0.0010	0.6250	0.0010	0.875	0.015	0.625	0.260	0.156	0.094
814-10	0.5005	0.0010	0.8750	0.0010	1.250	0.015	0.875	0.490	0.312	0.133
814-10SU	0.5005	0.0010	0.8750	0.0010	1.250	0.015	0.940	0.490	0.312	0.133
1018-12	0.6255	0.0010	1.1250	0.0010	1.500	0.015	1.000	0.550	0.375	0.133
1220-13	0.7508	0.0010	1.2500	0.0010	1.625	0.015	1.062	0.612	0.438	0.133
1220-13SU	0.7508	0.0010	1.2500	0.0010	1.625	0.015	1.160	0.612	0.438	0.133
1625-18	1.0008	0.0010	1.5625	0.0010	2.250	0.015	1.625	1.180	0.563	0.133
1625-18SU	1.0008	0.0010	1.5625	0.0010	2.250	0.015	1.750	1.180	0.563	0.133
2032-21	1.2508	0.0010	2.0000	0.0010	2.625	0.020	1.875	1.425	0.625	0.201
2438-24	1.5008	0.0015	2.3750	0.0015	3.000	0.020	2.250	1.670	0.750	0.201
3248-32	2.0012	0.0015	3.0000	0.0015	4.000	0.020	3.000	1.450	1.000	0.275
4060-40	2.5007	0.0015	3.7500	0.0015	5.000	0.025	3.750	1.600	1.250	0.275
4872-48	3.0003	0.0020	4.5000	0.0020	6.000	0.030	4.500	2.190	1.500	0.275
6496-64	4.0012	0.0020	6.0000	0.0020	8.000	0.040	6.000	-	2.000	0.275

Table continued on top of page 20

How to order:

For **Self Lubricated** Bearings, add the Suffix SL to part number.
Example: L1625-18SL

For Self Aligning Bearings, add the Suffix SA to part number.
Example: L1625-18SA

Available with or without seals.



BEARING NUMBER (L OR LX)	MAX. SHAFT DIA.	HOLE LOCATION TO BRG. I	HOUSING BORE		BEARING WEIGHT LBS (L)	BEARING WEIGHT LBS (LX)	MAX. STATIC LOAD LBS.
				TOL -.0000 +			
408-6	0.2495	on center	0.5000	0.0005	0.010	0.008	939
610-7	0.3745	on center	0.6250	0.0005	0.015	0.013	1643
610-7SU	0.3745	on center	0.6250	0.0005	0.015	0.013	1643
814-10	0.4995	5/8	0.8750	0.0005	0.046	0.034	3128
814-10SU	0.4995	5/8	0.8750	0.0005	0.046	0.034	3128
1018-12	0.6245	1/8	1.1250	0.0005	0.096	0.072	4691
1220-13	0.7495	1/8	1.2500	0.0005	0.125	0.091	6100
1220-13SU	0.7495	1/8	1.2500	0.0005	0.125	0.091	6100
1625-18	0.9995	1/8	1.5625	0.0005	0.247	0.184	11259
1625-18SU	0.9995	1/8	1.5625	0.0005	0.247	0.184	11259
2032-21	1.2495	3/16	2.0000	0.0010	0.500	0.381	16417
2438-24	1.4994	3/16	2.3750	0.0010	0.780	0.603	22512
3248-32	1.9994	5/16	3.0000	0.0010	1.540	1.190	40024
4060-40	2.4993	5/16	3.7500	0.0010	3.000	2.334	62518
4872-48	2.9992	5/16	4.5000	0.0010	5.060	4.080	90009
6496-64	3.9988	5/16	6.0000	0.0010	12.100	9.870	160048

Retaining Pin Location, LX inch series Bearings

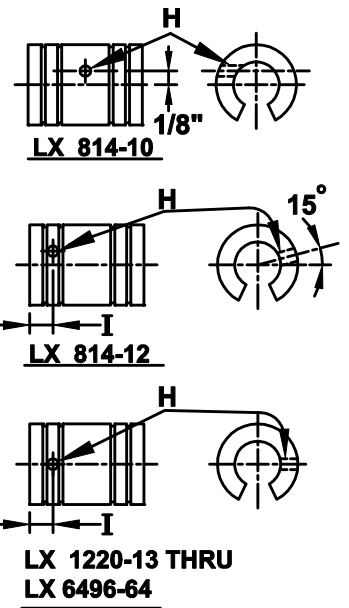

L or LX Bearings can be press fit, held in place with snap rings, or pinned in the housing with a retaining pin. Retaining pin location is illustrated above.

COMPOSITE LINEAR PILLOW BLOCK

With a relatively low coefficient of friction, LEE LINEAR® Composite Pillow Blocks are available in Ceramic and Self Lubricating models with or without the self aligning feature.

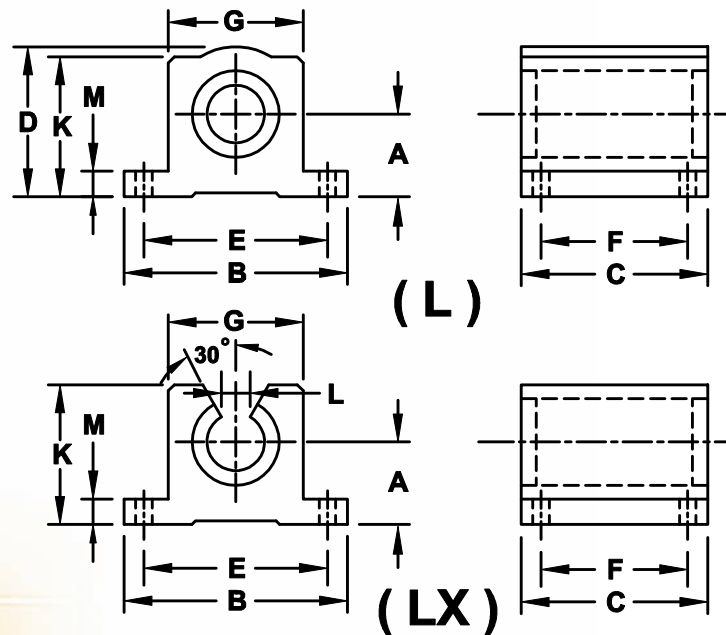
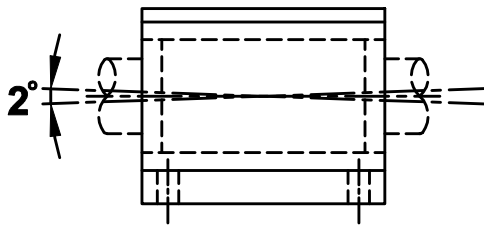

Table on top of page 21



PART NUMBER (L) (LX)	SHAFT DIA.		A ±.003	B	C	D	E ±.010	F ±.010	G	BOLT/ HOLE	K	L	M
	NOM.	MAX.										MIN.	MIN.
PB 408-6	1/4	0.2495	0.437	1.625	1.187	0.812	1.312	0.750	1.000	#8-5/32	0.750	0.093	0.187
PB 610-7	3/8	0.3745	0.500	1.750	1.312	0.937	1.437	0.875	1.125	#6-5/32	0.875	0.140	0.187
PB 814-10	1/2	0.4995	0.687	2.000	1.687	1.250	1.688	1.000	1.375	#8-5/32	1.125	0.312	0.250
PB 1018-12	5/8	0.6245	0.875	2.500	1.937	1.625	2.125	1.125	1.750	#6-3/16	1.437	0.375	0.281
PB 1220-13	3/4	0.7495	0.937	2.750	2.062	1.750	2.375	1.250	1.875	#8-3/16	1.562	0.437	0.312
PB 1625-18	1	0.9995	1.187	3.250	2.812	2.187	2.875	1.750	2.375	#10-7/32	2.000	0.562	0.375
PB 2032-21	1-1/4	1.2495	1.500	4.000	3.625	2.812	3.500	2.000	3.000	#10-7/32	2.500	0.625	0.437
PB 2438-24	1-1/2	1.4994	1.750	4.750	4.000	3.250	4.125	2.500	3.500	1/4-9/32	2.875	0.750	0.500
PB 3248-32	2	1.9994	2.125	6.000	5.000	4.062	5.250	3.250	4.500	3/8-13/32	3.625	1.000	0.625

Complete Pillow Block Units include Bearing, Grease Fitting, Retention Pin and Seals.
Self Lubricated Pillow Blocks normally supplied without seals unless requested.



Self Aligning Pillow Blocks allow 1° misalignment from shaft centerline, 2° total misalignment for applications where proper alignment is difficult or self alignment desirable.

PREFIXES	PART NUMBER	
	(L) (LX)	HOUSING BORE
PBH	408-6	0.5000/0.5005
PBH	610-7	0.6250/0.6255
PBH	814-10	0.8750/0.8755
PBH	1018-12	1.1250/1.1255
PBH	1220-13	1.2500/1.2505
PBH	1625-18	1.5625/1.5635
PBH	2032-21	2.0000/2.0010
PBH	2438-24	2.3750/2.3760
PBH	3248-32	3.0000/3.0010

How to order:

For Open Pillow Blocks, use Prefix LX before number. Example: LXPB1625-18

For Closed Pillow Blocks, use Prefix L before number. Example: LPB 1625-IS

For Self Aligning Pillow Blocks, add the Suffix SA to part number. Example: LPB1 625-18SA

For **Self Lubricated** Pillow Blocks, add the Suffix SL to part number. Example: LPB1625-18SL

COMPOSITE LINEAR TWIN PILLOW BLOCKS

LEE LINEAR® Twin Composite Pillow Blocks offer a composite property with double the dynamic load.

DOUBLE LENGTH PILLOW BLOCKS

Engineering Specifications

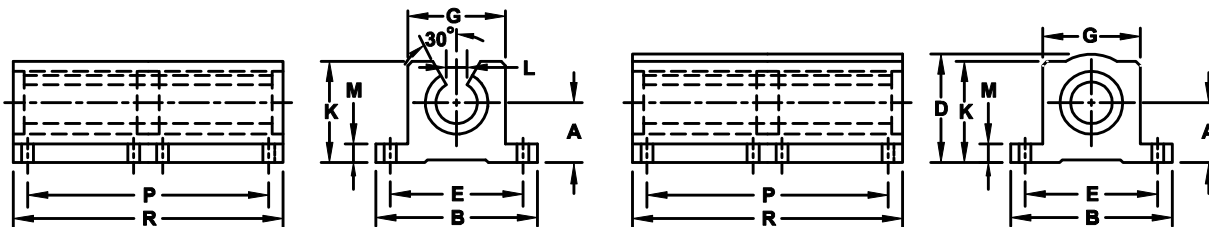

Table on top of page 22



Closed (LPB-T) and Open (LXPB-T)

Available in Ceramic or Self Lubricating styles

PART NUMBER	WORKING BORE		A ±.002	B	P	D	E		R	G	BOLT	HOLE	M MIN.	K
	INCHES	TOLERANCE					±.010	±.010						
LPB-4T	0.2505	+0.001	0.437	1-5/8	2-1/2	13/16	1.312	2.000	1	#6	5/32	3/16	3/4	
LPB-6T	0.3755	+0.001	0.500	1-3/4	2-3/4	15/16	1.437	2.250	1-1/8	#6	5/32	3/16	7/8	
L or LXPB-8T	0.5005	+0.001	0.687	2	3-1/2	1-1/4	1.688	2.500	1-3/8	#6	5/32	1/4	1-1/8	
L or LXPB-10T	0.6255	+0.001	0.875	2-1/2	4	1-5/8	2.125	3.000	1-3/4	#8	3/16	9/32	1-7/16	
L or LXPB-12T	0.7505	+0.001	0.937	2-3/4	4-1/2	1-3/4	2.375	3.500	1-7/8	#8	3/16	5/16	1-9/16	
L or LXPB-16T	1.0008	+0.001	1.187	3-1/4	6	2-3/16	2.875	4.500	2-3/8	#10	7/32	3/8	1-15/16	
L or LXPB-20T	1.2508	+0.001	1.500	4	7-1/2	2-13/16	3.500	5.500	3	#10	7/32	7/16	2-1/2	
L or LXPB-24T	1.5008	+0.0015	1.750	4-3/4	9	3-1/4	4.125	6.500	3-1/2	1/4	9/32	1/2	2-7/8	
L or LXPB-32T	2.0012	+0.0015	2.125	6	10	4-1/16	5.250	8.250	4-1/2	3/8	13/32	5/8	3-5/8	

Ceramic blocks supplied with seals and a grease fitting.

Self Lubricating series normally supplied without seals unless requested.

To purchase **Self Lubricating** series, add suffix **SL** to part number.

Advantages:

Interchangeable with standard twin linear ball bearing pillow blocks and twin LEE LINEAR® Roller Bearing Pillow Blocks.

FLANGE BLOCKS

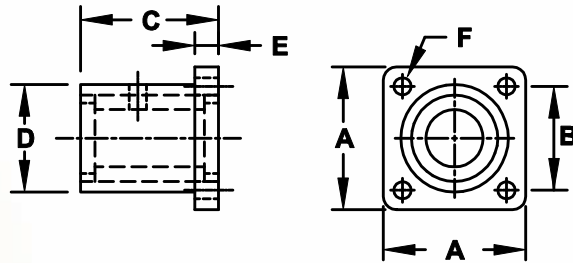

Available in Ceramic or Self Lubricating styles

PART NUMBER	SHAFT DIAMETER		A	B ±.010	C	D	E	F	
	NOM.	MAX.						BOLT	HOLE
LF8	1/2	0.4995	1-5/8	1.250	1-11/16	1-1/4	1/4	#8	3/16
LF12	3/4	0.7495	2-3/8	1.750	2-1/16	1-3/4	3/8	#10	7/32
LF16	1	0.9995	2-3/4	2.125	2-13/16	2-1/4	1/2	1/4	9/32

Ceramic and **Self Lubricating** bearings are available for self aligning applications.

To purchase the **Self Lubricating** bearing add the suffix **SL**.

To purchase the **Ceramic** bearing, use no suffix.

To purchase the Self Aligning option, add the suffix **SA** to part number.

Self Lubricating series supplied without seals, unless specified.

Advantages:

Dimensionally interchangeable with standard ball bushing flange blocks.

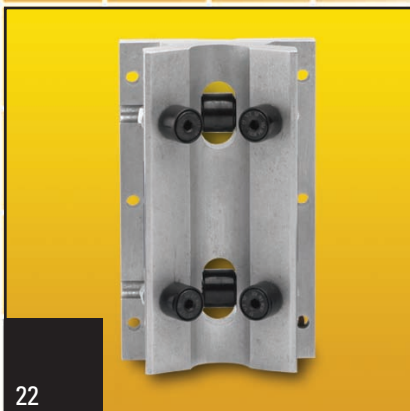

ROLLING BEARING PILLOW BLOCKS

The superiority of LEE LINEAR® Roller Bearing Pillow Blocks is inherent in the design. Available in single, double, and twin options, LEE Roller Bearing Pillow Blocks offer the following advantages over standard pillow blocks:

Easy Clearance Adjustment

The adjustable eccentric stud feature on the LEE Roller Bearing Pillow Block allows for simple radial clearance adjustment. The adjustment can accommodate “very loose” to slight “preload” conditions.

Self-Aligning

LEE designed the Roller Bearing Pillow Block with a higher shaft deflection tolerance and self alignment for ease of use.

Corrosion Resistant

With aluminum bodies and black oxide finished rollers, LEE LINEAR® Roller Bearing Pillow Blocks provide good corrosion resistance.

Operate at Higher Speeds

LEE LINEAR® Roller Bearing Pillow Blocks have larger “rolling” diameters to significantly increase operational speed, acceleration, and smoothness.

It's Easy to Switch to LEE LINEAR® Roller Bearing Pillow Blocks

LEE LINEAR® Roller Bearing Pillow Blocks have the same hole locations and critical dimensions as most other linear pillow blocks of the same shaft diameter size.

ROLLER BEARING PILLOW BLOCK TYPES

LEE offers single, twin, and double Roller Bearing Pillow Block types in various shaft diameters.

SINGLE PILLOW BLOCK

Low friction Single Pillow Blocks are selected for standard linear movement or for situations with severe shaft deflection. Self Aligning LEE LINEAR® Single Pillow Blocks can handle misalignment.

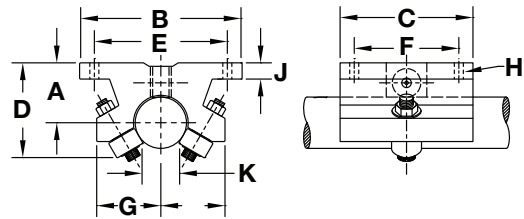

DIMENSIONS & LOAD RATINGS FOR SINGLE PILLOW BLOCKS

SINGLE PILLOW BLOCK MODEL #	SHAFT DIA.	DYN. LOAD RATING	WT. (LBS)	A ±.003	B	C	D	E ±.005	F ±.005	G	H		J	K
											BOLT	HOLE		
SPB-8-OPN	1/2	400	0.400	0.687	2	1-1/2	1-5/32	1.688	1.000	1	#6	5/32	.240	5/16
SPB-10-OPN	5/8	500	0.500	0.875	2-1/2	1-3/4	1-13/32	2.125	1.125	1-1/16	#8	3/16	.270	3/8
SPB-12-OPN	3/4	600	0.600	0.937	2-3/4	1-7/8	1-9/16	2.375	1.250	1-1/16	#8	3/16	.303	7/16
SPB-16-OPN	1	955	1.000	1.187	3-1/4	2-5/8	2	2.875	1.750	1-3/8	#10	7/32	.360	11/16
SPB-20-OPN	1-1/4	1400	2.000	1.500	4	3-3/8	2-9/16	3.500	2.000	1-3/4	#10	7/32	.424	13/16
SPB-24-OPN	1-1/2	1660	2.800	1.750	4-3/4	3-3/4	2-7/8	4.125	2.500	1-7/8	1/4	9/32	.474	1-1/16
SPB-32-OPN	2	2400	5.000	2.125	6	4-3/4	3-1/2	5.250	3.250	2-1/2	3/8	13/32	.600	1-3/8
SPB-48-OPN	3	6260	14.000	3.500	8-3/8	5-1/2	5-1/2	7.000	4.000	3-5/8	5/8	21/32	1.000	2-1/8



DIMENSIONS & LOAD RATINGS FOR METRIC SINGLE PILLOW BLOCKS

SINGLE PILLOW BLOCK MODEL #	SHAFT DIA.	DYN. LOAD RATING	WT. (LBS)	A ±.003	B	C	D	E ±.005	F ±.005	G	H		J	K
											BOLT	HOLE		
MSPB-16-OPN	16mm	500	0.500	0.877	2-1/2	1-3/4	1-13/32	2.125	1.125	1-1/16	#8	3/16	0.270	3/8
MSPB-20-OPN	20mm	600	0.600	0.956	2-3/4	1-7/8	1-9/16	2.375	1.250	1-1/16	#8	3/16	0.300	7/16
MSPB-25-OPN	25mm	955	1.000	1.179	3-1/4	2-5/8	2	2.875	1.750	1-3/8	#10	7/32	0.360	11/16
MSPB-30-OPN	30mm	1400	2.000	1.465	4	3-3/8	2-9/16	3.500	2.000	1-3/4	#10	7/32	0.424	13/16

TURNING A CURVE

A Single Roller Bearing Pillow Block, both inch and metric, has the ability to turn a curve or run on a non-linear system. The following table lists the minimum track radius that the Single Pillow Block can tolerate without additional alteration:

Pillow Block Size	8	10	12	16	20	24	32	48	64
Min. Shaft Radius	6"	12"	14"	18"	36"	40"	44"	52"	60"

CANTILEVER LOADS OR MOMENTS

When a linear motion system is subjected to a cantilever load or moment, the system designer must take into consideration these type of loads will greatly effect the performance of the system. Roller Bearing Pillow Blocks are not suitable for these types of applications because the moments will load the side rollers and cause premature failure. If the moments or cantilever loads are minor, loads may be acceptable. **For this reason we ask that you consult the factory.**



DOUBLE PILLOW BLOCK

With double the capacity of the single pillow block, LEE LINEAR® Double Pillow Blocks offer a double dynamic load rating in a similar mounting footprint. LEE LINEAR® Double Pillow Blocks are used when longer travel life, or an increase in load capacity is required.

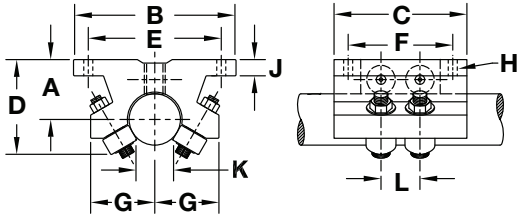

DIMENSIONS & LOAD RATINGS FOR DOUBLE PILLOW BLOCKS

DOUBLE PILLOW BLOCK MODEL #	SHAFT DIA.	DYN. LOAD RATING (LBS)	WT. (LBS)	A ±.003	B	C	D	E ±.005	F ±.005	G	H		J	K	L
											BOLT	HOLE			
DPB-8-OPN	1/2	800	0.500	0.687	2	2	1-5/32	1.688	1.625	1	#6	5/32	0.240	5/16	0.562
DPB-10-OPN	5/8	1000	0.700	0.875	2-1/2	2-1/2	1-13/32	2.125	2.000	1-1/16	#8	3/16	0.270	3/8	0.526
DPB-12-OPN	3/4	1200	0.800	0.937	2-3/4	2-5/8	1-9/16	2.375	1.250	1-1/16	#8	3/16	0.380	7/16	0.562
DPB-16-OPN	1	1910	1.200	1.187	3-1/4	2-5/8	2	2.875	1.750	1-3/8	#10	7/32	0.360	11/16	0.720
DPB-20-OPN	1-1/4	2800	2.300	1.500	4	3-3/8	2-9/16	3.500	2.000	1-3/4	#10	7/32	0.424	13/16	0.937
DPB-24-OPN	1-1/2	3320	3.000	1.750	4-3/4	3-3/4	2-7/8	4.125	2.500	1-7/8	1/4	9/32	0.474	1-1/16	0.937
DPB-32-OPN	2	4800	5.500	2.125	6	4-3/4	3-1/2	5.250	3.250	2-1/2	3/8	13/32	0.603	1-3/8	1.187
DPB-48-OPN	3	12500	20.000	3.500	8-3/8	7-1/4	5-1/2	7.000	5.875	3-5/8	5/8	21/32	1.000	2-1/8	2.080

DIMENSIONS & LOAD RATINGS FOR METRIC DOUBLE PILLOW BLOCKS

DOUBLE PILLOW BLOCK MODEL #	SHAFT DIA.	DYN. LOAD RATING (LBS)	WT. (LBS)	A ±.003	B	C	D	E ±.005	F ±.005	G	H		J	K	L
											BOLT	HOLE			
MDPB-16-OPN	16mm	1000	0.700	0.877	2-1/2	2-1/2	1-13/32	2.125	2.000	1-1/16	#8	3/16	0.270	3/8	0.562
MDPB-20-OPN	20mm	1200	0.800	0.956	2-3/4	2-5/8	1-9/16	2.375	1.250	1-1/16	#8	3/16	0.300	7/16	0.562
MDPB-25-OPN	25mm	1910	1.200	1.179	3-1/4	2-5/8	2	2.875	1.750	1-3/8	#10	7/32	0.360	11/16	0.720
MDPB-30-OPN	30mm	2800	3.000	1.465	4	3-3/8	2-9/16	3.500	2.000	1-3/4	#10	7/32	0.424	13/16	0.937



TWIN PILLOW BLOCK

The Twin Pillow Block load rating is the same as the Double Pillow Block and is a good choice when using only one pillow block per shaft or in applications subjected to cantilever loads, or movements. The twin model also offers an additional pair of mounting holes.

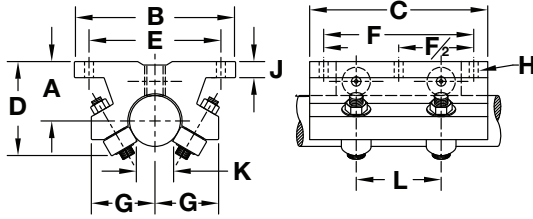

DIMENSIONS & LOAD RATINGS FOR TWIN PILLOW BLOCKS

TWIN PILLOW BLOCK MODEL #	SHAFT DIA.	DYN. LOAD RATING (LBS)	WT. (LBS)	A ±.003	B	C	D	E ±.005	F ±.005	G	H		J	K	L
											BOLT	HOLE			
TWN-8-OPN	1/2	800	0.800	0.687	2	3-1/2	1-5/32	1.688	2.500	1	#6	5/32	0.240	5/16	1.500
TWN-10-OPN	5/8	1000	1.000	0.875	2-1/2	4	1-13/32	2.125	3.000	1-1/16	#8	3/16	0.270	3/8	2.125
TWN-12-OPN	3/4	1200	1.200	0.937	2-3/4	4-1/2	1-9/16	2.375	3.500	1-1/16	#8	3/16	0.300	7/16	2.500
TWN-16-OPN	1	1910	2.300	1.187	3-1/4	6	2	2.875	4.500	1-3/8	#10	7/32	0.360	11/16	3.750
TWN-20-OPN	1-1/4	2800	4.400	1.500	4	7-1/2	2-9/16	3.500	5.500	1-3/4	#10	7/32	0.424	13/16	4.625
TWN-24-OPN	1-1/2	3320	6.500	1.750	4-3/4	9	2-7/8	4.125	6.500	1-7/8	1/4	9/32	0.474	1-1/16	5.500
TWN-32-OPN	2	4800	12.400	2.125	6	12	3-1/2	5.250	10.500	2-1/2	3/8	13/32	0.600	1-3/8	8.250

DIMENSIONS & LOAD RATINGS FOR METRIC TWIN PILLOW BLOCKS

TWIN PILLOW BLOCK MODEL #	SHAFT DIA.	DYN. LOAD RATING (LBS)	WT. (LBS)	A ±.003	B	C	D	E ±.005	F ±.005	G	H		J	K	L
											BOLT	HOLE			
MTWN-16-OPN	16mm	1000	1.000	0.877	2-1/2	4	1-13/32	2.125	3.000	1-1/16	#8	3/16	0.270	3/8	2.125
MTWN-20-OPN	20mm	1200	1.200	0.956	2-3/4	4-1/2	1-9/16	2.375	3.500	1-1/16	#8	3/16	0.300	7/16	2.500
MTWN-25-OPN	25mm	1910	2.300	1.179	3-1/4	6	2	2.875	4.500	1-3/8	#10	7/32	0.360	11/16	3.750
MTWN-30-OPN	30mm	2800	4.400	1.465	4	7-1/2	2-9/16	3.500	5.500	1-3/4	#10	7/32	0.424	13/16	4.625

ROLLER BEARING PILLOW BLOCK TECHNICAL INFORMATION

Adjustments

Roller Bearing Pillow Blocks are factory set for LEE LINEAR® **60 Plus**® shafting tolerance code "B". Adjustments can be made to the adjustable eccentric cam follower to either increase or decrease the shaft clearance.

Located on the same side of the pillow block as the set screw, the eccentric cam follower is

adjusted by using a stubby allen wrench while allowing a 0.001" feeler gauge to freely move between the shaft and the eccentric roller. The fixed side must remain in contact with the shaft. If care is taken not to overload the roller, then a slight pre-load is possible. Rollers should never be tightened to the point where they cannot move freely.

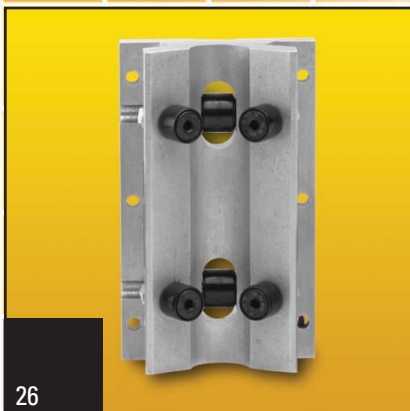

Determining Pillow Block Size and Model

To determine the proper size pillow block for an application, refer to the chart below using the worse case load applied to the pillow block and the required travel life. Where the two lines intersect, select the pillow block above where the lines intersect. This should be suitable for anticipated travel life and loading. Note: Shock, vibration, and moments may affect the life of the pillow block.

Chart is rated at 10% accuracy. Figures are based on a safety factor of one.

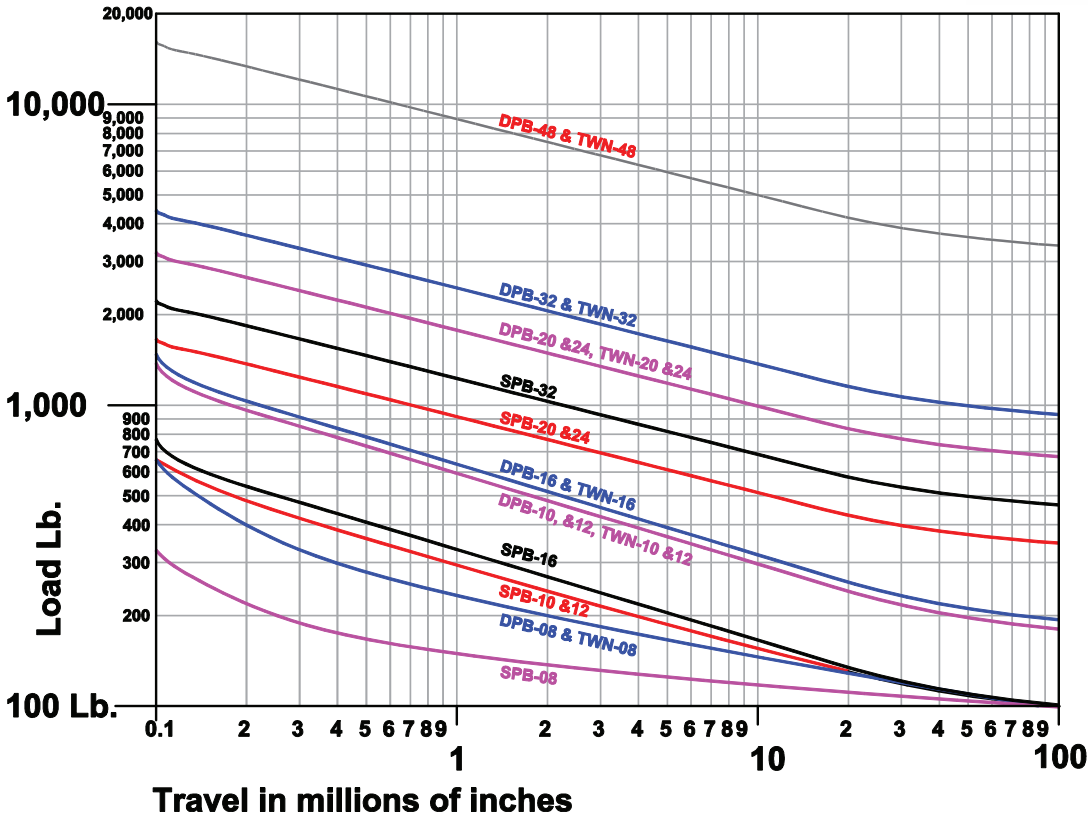

ROLLING BEARING PILLOW BLOCKS OPTIONS

To increase the performance of LEE LINEAR® Roller Bearing Pillow Blocks, LEE offers the following options.

TOP GREASE OPTION

The Roller Bearing Pillow Block rollers are lubricated and sealed. In some applications it is desired to re-grease the main support roller. The "top grease option" can help achieve full bearing life in applications that reduce or contaminate the grease of the roller. Such conditions may exist in applications where solvents or contaminants leach out the grease through the vents in the seals, or where contaminants are so fine or extreme they must be purged out of the roller with fresh grease. The "top grease option" is also recommended when high speeds or high temperatures are present.

The Top Grease Option is available on Pillow Blocks that are 1-1/4" or larger. To order, add the suffix, "TG" after the pillow block model number.

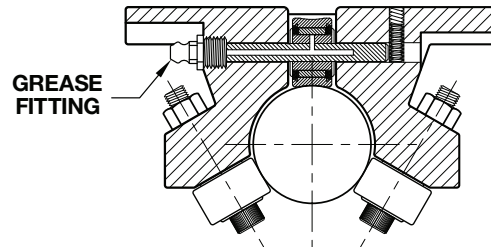



PILLOW BLOCK REBUILD KITS

One LEE LINEAR® Pillow Block Rebuild Kit contains all the parts required for a complete unit rebuild:

- One fixed side roller
- One eccentric side roller
- One top support roller
- One top roller axle
- One set screw

To rebuild a double or twin pillow block, please order two kits.

To ensure the receipt of the correct kit, please provide the four digit run number stamped onto the end face of the pillow block. For example, for one kit for a 1" pillow block with the run number 1047, the order number would be: BK 16-1047.

Although individual parts are available, LEE recommends all parts of a pillow block be replaced before re-installation.

SCRAPER OPTION

Reduce the amount of dirt accumulation that lands on the top of the Roller Bearing Pillow Block shaft with the LEE LINEAR® Scraper Option. Available only on specially machined pillow blocks, the Scraper is mounted to each end of the bearing assembly to clean the shaft in either direction. Made from spring-tempered beryllium copper that conforms to the shaft diameter, the Scraper will perform successfully after a short break in period. Scraper model is not available as a retrofit. To order this option, add the suffix "-S" after the pillow block model number.

FLOATING OPTION

The only product on the market that addresses the non-parallel shafting problem is LEE LINEAR®'s Floating Option. Also useful when trying to align long shafts, Floating pillow blocks should be used in conjunction with a standard pillow block. Special grease is included for the grooves on top of each floating pillow block. During installation do not over-tighten the mounting bushings as this will cause them to bind. To order, add the prefix, "F-" to the single, double, or twin Roller Pillow Block number.

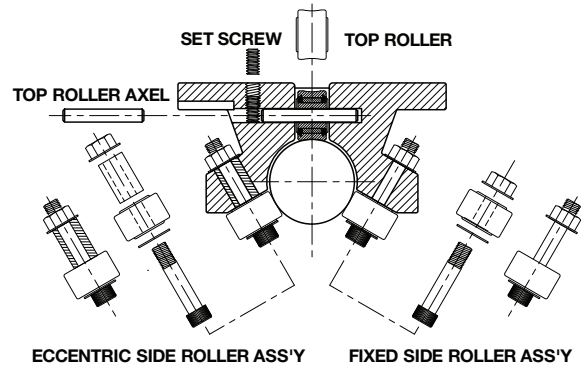

REBUILD KIT#	SHAFT DIA.	REBUILD KIT#	NOM. DIA.
BK08	1/2	BK20	1-1/4
BK10	5/8	BK24	1-1/2
BK12	3/4	BK32	2
BK16	1	BK48	3

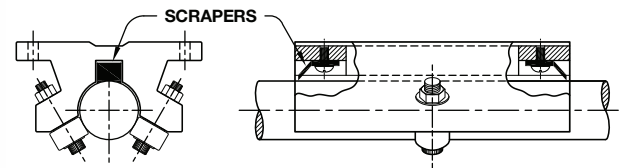

PillowBlockSize	8, 10, 12	16	20, 24	32	48, 64
FloatingMovement	1/16	3/32	1/8	5/32	3/16

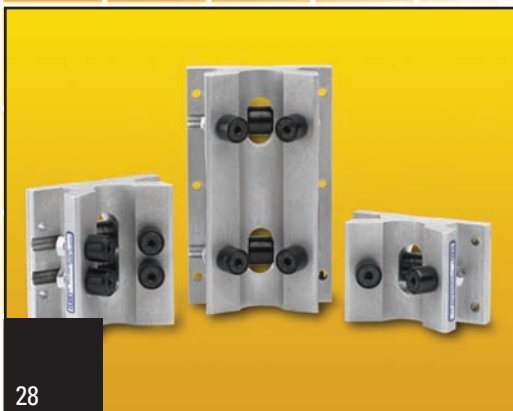
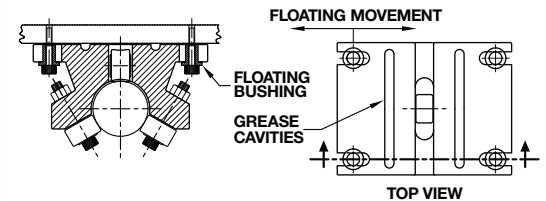

CROSS REFERENCE GUIDE

Below is a chart that cross-references our product with competitors.
For more assistance, please call LEE at (800) 221-0811 or (732) 752-5200.

STANDARD LINEAR BALL BEARINGS

LEE	LEE SEALED	THOMSON	THOMSON SEALED	INA	INA SEALED	NB STEEL RETAINER	NB STEEL RETAINER SEALED	NB PLST'C RETAINER	NB PLST'C RETAINER SEALED
A4812	A4812DD	A4812	–	KBZ04	KBZ04PP	SW4	SW4UU	SW4G	SW4GUU
A61014	A61014DD	A61014	–	KBZ06	KBZ06PP	SW6	SW6UU	SW6G	SW6GUU
A81420	A81420DD	A81420	A81420DD	KBZ08	KBZ08PP	SW8	SW8UU	SW8G	SW8GUU
A101824	A101824DD	A101824	–	KBZ10	KBZ10PP	SW10	SW10UU	SW10G	SW10GUU
A122026	A122026DD	A122026	A122026DD	KBZ12	KBZ12PP	SW12	SW12UU	SW12G	SW12GUU
A162536	A162536DD	A162536	A162536DD	KBZ16	KBZ16PP	SW16	SW16UU	SW16G	SW16GUU
A203242	A203242DD	A203242	–	KBZ20	KBZ20PP	SW20	SW20UU	SW20G	SW20GUU
A243848	A243848DD	A243848	–	KBZ24	KBZ24PP	SW24	SW24UU	SW24G	SW24GUU
A324864	A324864DD	A324864	–	KBZ32	KBZ32PP	SW32	SW32UU	SW32G	SW32GUU

OPEN TYPE LINEAR BALL BEARINGS

LEE	LEE SEALED	THOMSON	THOMSON SEALED	INA	INA SEALED	NB STEEL RETAINER	NB STEEL RETAINER SEALED	NB PLST'C RETAINER	NB PLST'C RETAINER SEALED
OPN81420	OPN81420DD	OPN81420	OPN81420DD	KBZ080P	KBZ080PPP	SW80P	SW80PUU	SW80G0P	SW80G0PUU
OPN101824	OPN101824DD	OPN101824	–	KBZ100P	KBZ100PPP	SW100P	SW100PUU	SW100G0P	SW100G0PUU
OPN122026	OPN122026DD	OPN122026	OPN122026DD	KBZ120P	KBZ120PPP	SW120P	SW120PUU	SW120G0P	SW120G0PUU
OPN162536	OPN162536DD	OPN162536	OPN162536DD	KBZ160P	KBZ160PPP	SW160P	SW160PUU	SW160G0P	SW160G0PUU
OPN203242	OPN203242DD	OPN203242	–	KBZ200P	KBZ200PPP	SW200P	SW200PUU	SW200G0P	SW200G0PUU
OPN243848	OPN243848DD	OPN243848	–	KBZ240P	KBZ240PPP	SW240P	SW240PUU	SW240G0P	SW240G0PUU
OPN324864	OPN324864DD	OPN324864	–	KBZ320P	KBZ320PPP	SW320P	SW320PUU	SW320G0P	SW320G0PUU

HI LOAD – SELF ALIGNING LINEAR BALL BEARINGS

LEE	THOMSON	NB	INA
SU06B	SUPER6	TW6UU	KX6PP
SU08B	SUPER8	TW8UU	KX8PP
SU10B	SUPER10	TW10UU	KX10PP
SU12B	SUPER12	TW12UU	KX12PP
SU16B	SUPER16	TW16UU	KX16PP
SU20B	SUPER20	TW20UU	KX20PP
SU24B	SUPER24	TW24UU	KX24PP
SU080PB	SUPER80PN	TW80PUU	KX08PP
SU100PB	SUPER100PN	TW100PUU	KX010PP
SU120PB	SUPER120PN	TW120PUU	KX012PP
SU160PB	SUPER160PN	TW160PUU	KX016PP
SU200PB	SUPER200PN	TW200PUU	KX020PP
SU240PB	SUPER240PN	TW240PUU	KX024PP
SPB8B	SPB8UU	TWA8UU	KGX8PP
SPB10B	SPB10UU	TWA10UU	KGX10PP
SPB12B	SPB12UU	TWA12UU	KGX12PP
SPB16B	SPB16UU	TWA16UU	KGX16PP
SPB20B	SPB20UU	TWA20UU	KGX20PP
SPB24B	SPB24UU	TWA24UU	KGX24PP
SPB80PB	SPB80PN	TWD8UU	KGX08PP
SPB100PB	SPB100PN	TWD10UU	KGX010PP
SPB120PB	SPB120PN	TWD12UU	KGX012PP
SPB160PB	SPB160PN	TWD16UU	KGX016PP
SPB200PB	SPB200PN	TWD20UU	KGX020PP
SPB240PB	SPB240PN	TWD24UU	KGX024PP



SHAFT AND RAIL SYSTEMS

When purchasing individual components takes up too much time, turn to LEE LINEAR®. We offer Shaft and Rail Systems composed of high-quality LEE LINEAR® linear motion components in six standard configurations, available in four different sizes. LEE LINEAR® Systems also come with the option of carriage plates, with or without mounted pillow blocks.

SYSTEM 1

LEE LINEAR® System 1 is manufactured with LEE LINEAR® Roller Bearing Pillow Block(s), one 60 Plus® precision case hardened and ground shaft, and two steel support blocks.

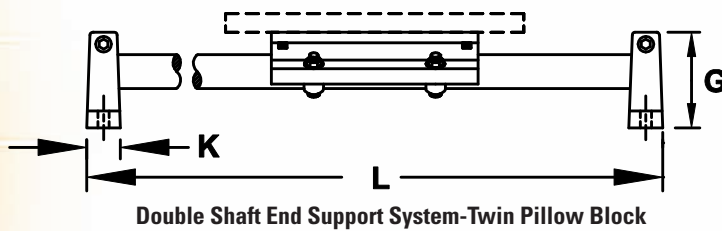
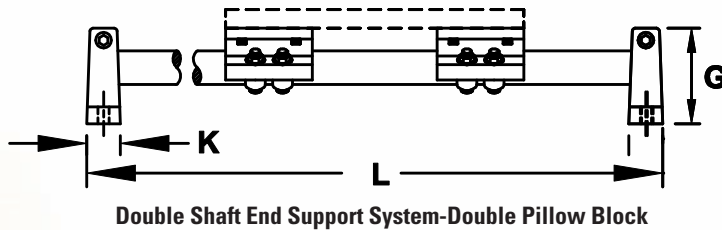
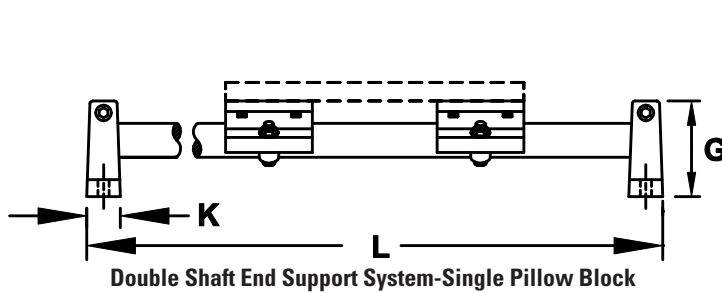

See table on top of page 31

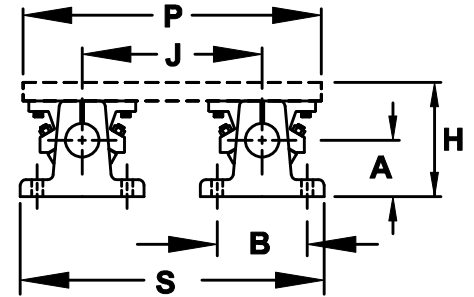

2 SYSTEMS

SINGLE

- 2 Single Pillow Blocks
- 2 Support Blocks
- 1 Hardened Shaft
- #S1S

DOUBLE

- 2 Double Pillow Blocks
- 2 Support Blocks
- 1 Hardened Shaft
- #S1D

TWIN

- 1 Twin Pillow Block
- 2 Support Blocks
- 1 Hardened Shaft
- #S1T

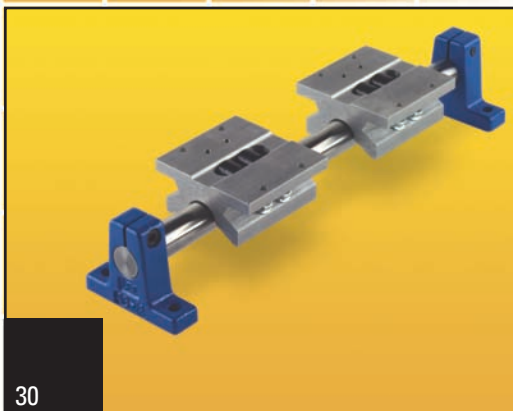

PART NO.	SHAFT DIA.	TOTAL B.D.R. (LBS)	A	B	G	H*	J*	K*	P*	S*
S1S08	0.500	800	1.000	2.000	1.630	2.187	3.250	0.630	5.500	5.250
S1D08	0.500	1600	1.000	2.000	1.630	2.187	3.250	0.630	5.500	5.250
S1T08	0.500	800	1.000	2.000	1.630	2.187	3.250	0.630	5.500	5.250
S1S12	0.750	1200	1.250	2.750	2.130	2.937	4.500	0.750	7.500	7.250
S1D12	0.750	2400	1.250	2.750	2.130	2.937	4.500	0.750	7.500	7.250
S1T12	0.750	1200	1.250	2.750	2.130	2.937	4.500	0.750	7.500	7.250
S1S16	1.000	1910	1.500	3.250	2.630	3.437	5.500	1.000	9.000	8.750
S1D16	1.000	3820	1.500	3.250	2.630	3.437	5.500	1.000	9.000	8.750
S1T16	1.000	1910	1.500	3.250	2.630	3.437	5.500	1.000	9.000	8.750
S1S24	1.500	3320	2.000	4.750	3.500	5.000	8.000	1.250	13.000	12.750
S1D24	1.500	6640	2.000	4.750	3.500	5.000	8.000	1.250	13.000	12.750
S1T24	1.500	3320	2.000	4.750	3.500	5.000	8.000	1.250	13.000	12.750

* When used with standard carriage plate.

How to order:

Use the nomenclature below to correctly order.

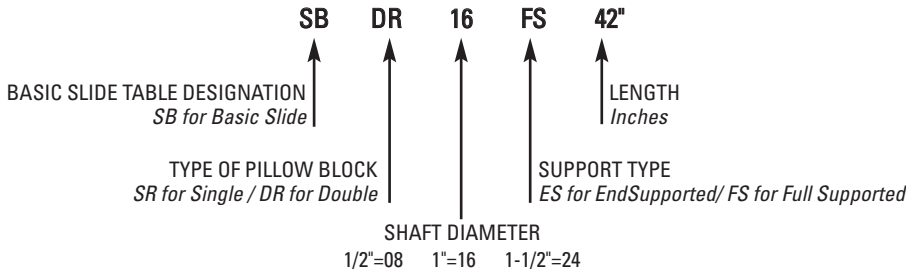



SYSTEM 2

LEE LINEAR® System 2 is manufactured with LEE LINEAR® Roller Bearing Pillow Blocks and one 60 Plus® precision case hardened and ground shaft that is mounted on a continuous aluminum support rail. To prevent the carriage from sliding off the shaft, end stops can be included.

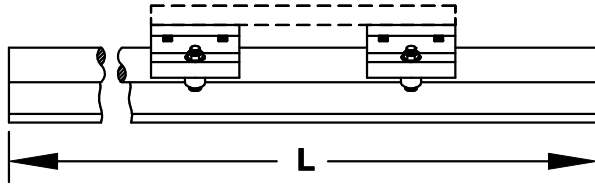

Double Shaft Fully Supported System-Single Pillow Block

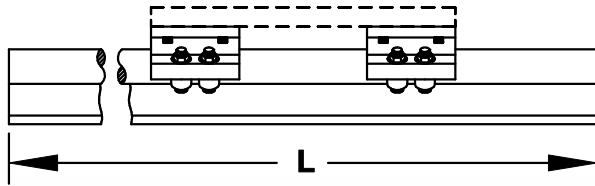

Double Shaft Fully Supported System-Double Pillow Block

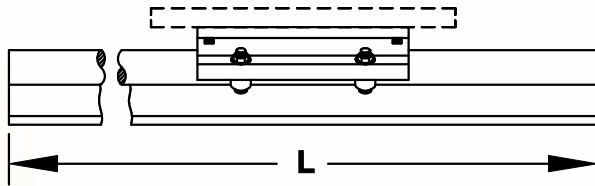

Double Shaft Fully Supported System-Twin Pillow Block

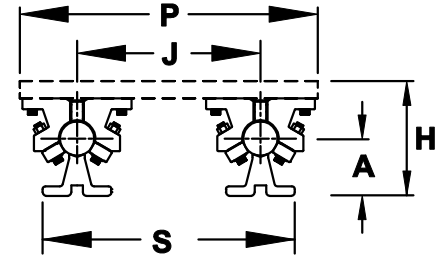

2 SYSTEMS

SINGLE

2 Single Pillow Blocks
Continuous Support Rail
1 Hardened Shaft
#S2S

DOUBLE

2 Double Pillow Blocks
Continuous Support Rail
1 Hardened Shaft
#S2D

TWIN

1 Twin Pillow Block
Continuous Support Rail
1 Hardened Shaft
#S2T

PART NO.	SHAFT DIA.	TOTAL B.D.R. (LBS)	A	H*	J*	P*	S*
S2S08	1/2	800	1.125	2.187	3.250	5.500	4.750
S2D08	1/2	1600	1.125	2.187	3.250	5.500	4.750
S2T08	1/2	800	1.125	2.187	3.250	5.500	4.750
S2S12	3/4	1200	1.500	2.937	4.500	7.500	6.250
S2D12	3/4	2400	1.500	2.937	4.500	7.500	6.250
S2T12	3/4	1200	1.500	2.937	4.500	7.500	6.250
S2S16	1	1910	1.750	3.437	5.500	9.000	7.630
S2D16	1	3820	1.750	3.437	5.500	9.000	7.630
S2T16	1	1910	1.750	3.437	5.500	9.000	7.630
S2S24	1-1/2	3320	2.500	5.000	8.000	13.000	11.000
S2D24	1-1/2	6640	2.500	5.000	8.000	13.000	11.000
S2T24	1-1/2	3320	2.500	5.000	8.000	13.000	11.000

* When used with standard carriage plates.



SLIDE TABLES

Standard Slide tables are available in standard Basic Slide and Full Slide. Both types of slides can be ordered with standard Roller Bearing Pillow Blocks, Composite Bearings, or Precision Plus linear ball bearings. LEE LINEAR® also offers slides tables custom designed to your specific application.

CUSTOM SLIDE TABLES

If the standard table dimensions do not fit your needs, please contact us for a custom table that is tailored to your exact requirements. You can use the components of your choice in our custom slides.

Our SBC Linear Guides have become a new addition to our custom slide selection. When moments are high, or cantilevered, linear guides are the answer to the problem. We can manufacture slides using linear guides, metric ball screws, and aluminum base and carriage plates. Custom slides can be designed, engineered, and manufactured to your requirements!

STANDARD SLIDE TABLES

LEE LINEAR® standard Slide Tables are manufactured using LEE LINEAR® 60 Plus® or 440C stainless steel shafting and patented LEE LINEAR® Roller Bearing Pillow Blocks. Available in three sizes with or without ball screw, and with single or double Roller Bearing Pillow Blocks. All slide tables are pre-assembled, pre-aligned, and factory tested ready for installation.



BASIC SLIDE

LEE LINEAR® Basic Slide Tables are available in three ball screw sizes: 0.50", 1.00", and 1.5" and come with the choice of supported or unsupported shafts.

UNSUPPORTED SLIDE

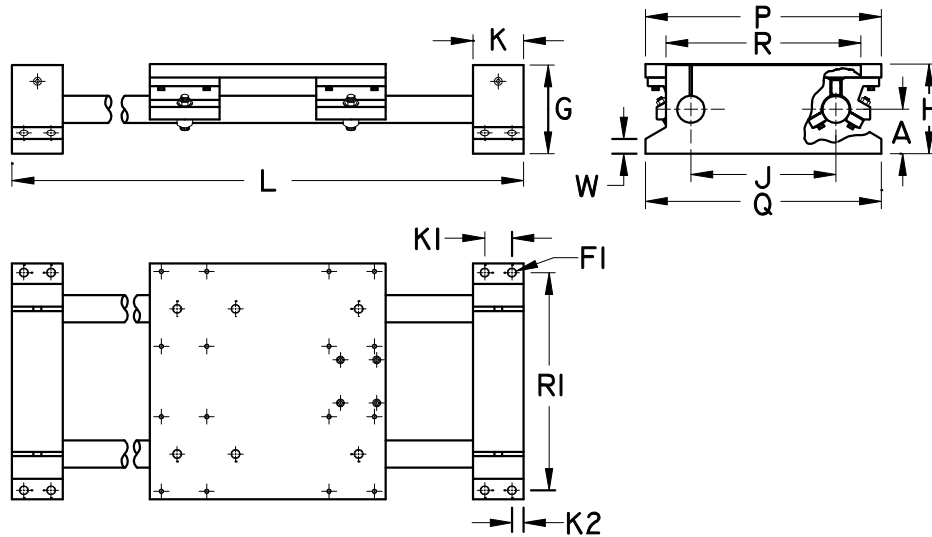

PART NO.	SHAFT DIA.	TOTAL B.D.R. (LBS)	A	F1	G	H	J	K	K1	K2
SBSR08ES	1/2	1600	1.125	0.190	2.380	2.187	3.250	1.500	0.750	0.380
SBDR08ES	1/2	3200	1.125	0.190	2.380	2.187	3.250	1.500	0.750	0.380
SBSR16ES	1	3820	1.750	0.280	3.370	3.437	5.500	2.200	1.200	0.500
SBDR16ES	1	7640	1.750	0.280	3.370	3.437	5.500	2.200	1.200	0.500
SBSR24ES	1-1/2	6640	2.500	0.340	4.870	5.000	8.000	2.800	1.500	0.650
SBDR24ES	1-1/2	13280	2.500	0.340	4.870	5.000	8.000	2.800	1.500	0.650

PART NO.	P	Q	R	R1	W
SBSR08ES	5.500	5.300	4.250	4.800	0.480
SBDR08ES	5.500	5.300	4.250	4.800	0.480
SBSR16ES	9.000	8.700	7.250	8.000	0.600
SBDR16ES	9.000	8.700	7.250	8.000	0.600
SBSR24ES	13.000	13.000	10.750	12.000	0.810
SBDR24ES	13.000	13.000	10.750	12.000	0.810

How to order:

Use the nomenclature below to correctly order your slide.

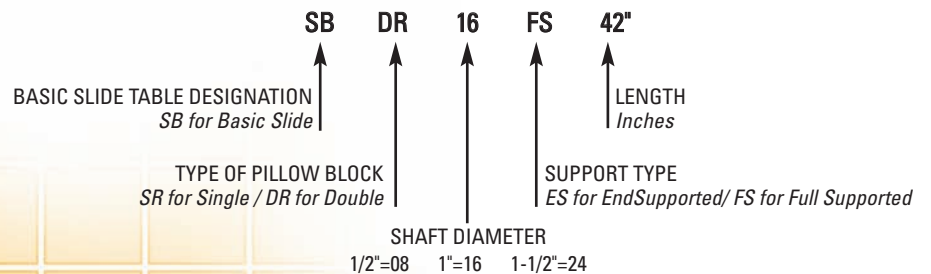

SUPPORTED SLIDE

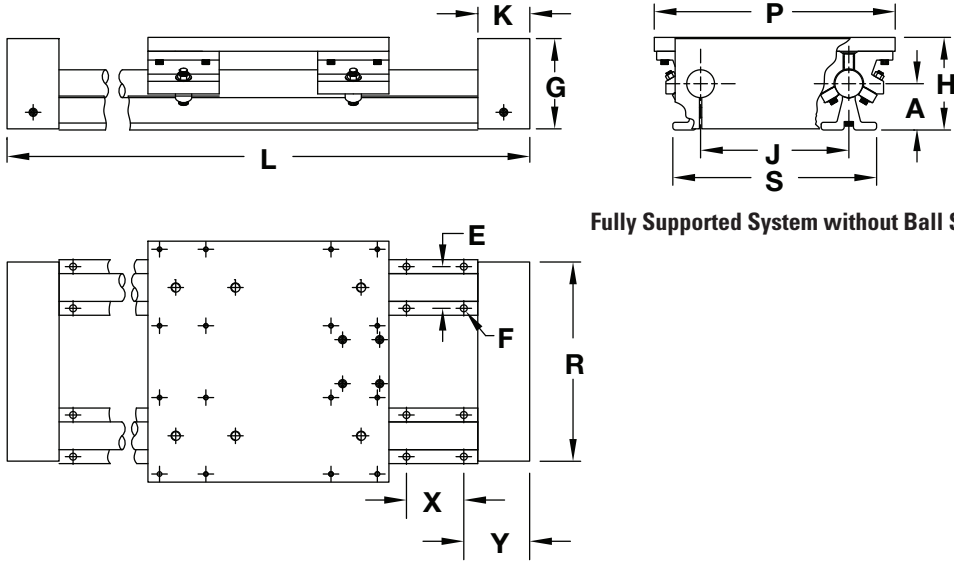

Fully Supported System without Ball Screw

PART NO.	SHAFT DIA.	TOTAL B.D.R. (LBS)	A	E	F	G	H	J	K	P	R
SBSR08FS	1/2	1600	1.125	1.000	0.169	2.380	2.187	3.250	1.500	5.500	4.250
SBDR08FS	1/2	3200	1.125	1.000	0.169	2.380	2.187	3.250	1.500	5.500	4.250
SBSR16ES	1	3820	1.750	1.500	0.281	3.370	3.437	5.500	2.200	9.000	7.250
SBDR16FS	1	7640	1.750	1.500	0.281	3.370	3.437	5.500	2.200	9.000	7.250
SBSR24FS	1-1/2	6640	2.500	2.250	0.343	4.870	5.000	8.000	2.800	13.000	10.750
SBDR24FS	1-1/2	13280	2.500	2.250	0.343	4.870	5.000	8.000	2.800	13.000	10.750

PART NO.	S	X	Y
SBSR08FS	4.750	4.000	2.000
SBDR08FS	4.750	4.000	2.000
SBSR16FS	7.630	6.000	3.000
SBDR16FS	7.630	6.000	3.000
SBSR24FS	11.000	8.000	4.000
SBDR24FS	11.000	8.000	4.000



FULL SLIDE SUPPORTED SLIDE SYSTEM WITH BALL SCREW

LEE LINEAR® Full Slide Tables are complete systems ready for installation and motor mounting. LEE LINEAR® Full Slide Tables are available with shafting either fully supported or end supported.

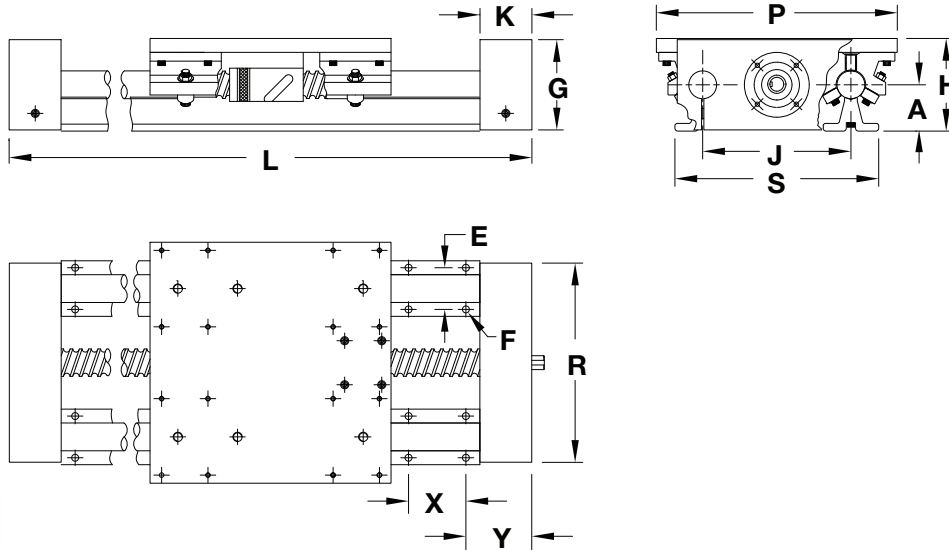

PART NO.	SHAFT DIA.	TOTAL B.D.R. (LBS)	A	E	F	G	H	J	K	P	R	S
SFSR08FS	1/2	1600	1.125	1.000	0.169	2.100	2.187	3.250	1.500	5.500	4.250	4.750
SFDR08FS	1/2	3200	1.125	1.000	0.169	2.100	2.187	3.250	1.500	5.500	4.250	4.750
SFSR16FS	1	3820	1.750	1.500	0.281	3.370	3.437	5.500	2.200	9.000	7.250	7.630
SFDR16FS	1	7640	1.750	1.500	0.281	3.370	3.437	5.500	2.200	9.000	7.250	7.630
SFSR24FS	1-1/2	6640	2.500	2.250	0.343	4.870	5.000	8.000	2.800	13.000	10.750	11.000
SFDR24FS	1-1/2	13280	2.500	2.250	0.343	4.870	5.000	8.000	2.800	13.000	10.750	11.000

PART NO.	X	Y	STD. BALL SCREW DIA.	STD. BALL SCREW PITCH.
SFSR08FS	4.000	2.000	5/8	0.200
SFDR08FS	4.000	2.000	5/8	0.200
SFSR16FS	6.000	3.000	1	1.000
SFDR16FS	6.000	3.000	1	1.000
SFSR24FS	8.000	4.000	1-1/2	1.000
SFDR24FS	8.000	4.000	1-1/2	1.000

Other ball screw pitches are available.



UNSUPPORTED SLIDE SYSTEM WITH BALL SCREW

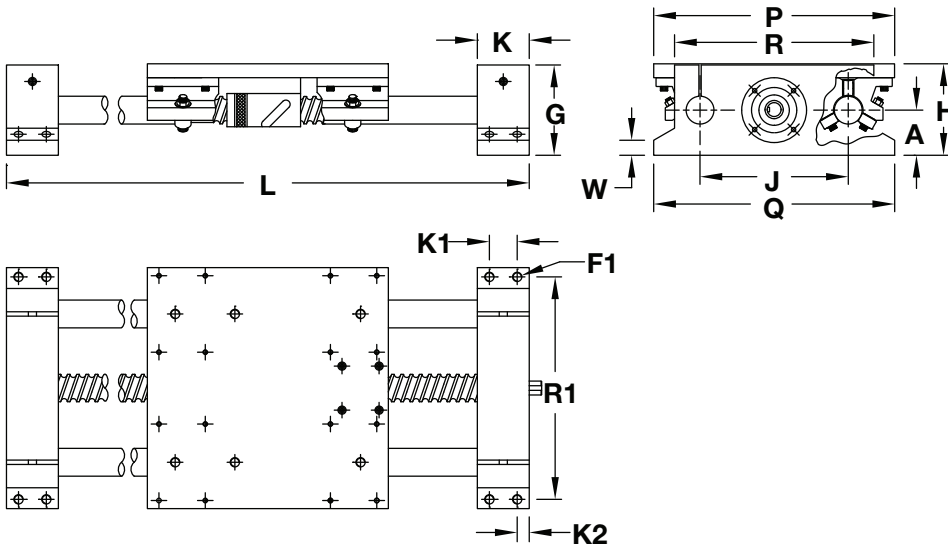

PART NO.	SHAFT DIA.	TOTAL B.D.R. (LBS)	A	F1	G	H	I	K	K1	K2	P	Q
SFSR08ES	1/2	1600	1.125	0.190	2.100	2.187	3.250	1.500	0.750	0.380	5.500	5.300
SFDR08ES	1/2	3200	1.125	0.190	2.100	2.187	3.250	1.500	0.750	0.380	5.500	5.300
SFSR16ES	1	3820	1.750	0.280	3.370	3.437	5.500	2.200	1.200	0.500	9.000	8.700
SFDR16ES	1	7640	1.750	0.280	3.370	3.437	5.500	2.200	1.200	0.500	9.000	8.700
SFSR24ES	1-1/2	6640	2.500	0.340	4.870	5.000	8.000	2.800	1.500	0.650	13.000	13.000
SFDR24ES	1-1/2	13280	2.500	0.340	4.870	5.000	8.000	2.800	1.500	0.650	13.000	13.000

PART NO.	R	R1	W	STD. BALL SCREW DIA.	STD. BALL SCREW PITCH.
SFSR08ES	4.250	4.800	0.480	5/8	0.200
SFDR08ES	4.250	4.800	0.480	5/8	0.200
SFSR16ES	7.250	8.000	0.600	1	1.000
SFDR16ES	7.250	8.000	0.600	1	1.000
SFSR24ES	10.750	12.000	0.810	1-1/2	1.000
SFDR24ES	10.750	12.000	0.810	1-1/2	1.000

Other ball screw pitches are available.

How to order:

Use the nomenclature below to correctly order.

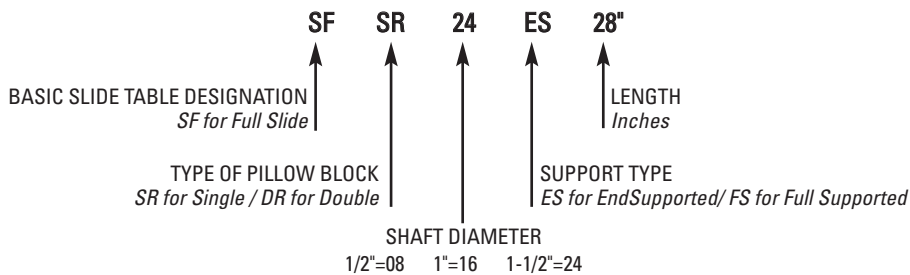



ACCESSORIES

CARRIAGE PLATES

Ready for immediate installation, LEE LINEAR® Carriage Plates are machined from cast aluminum tool and jig plate. Available with or without mounted linear bearings.

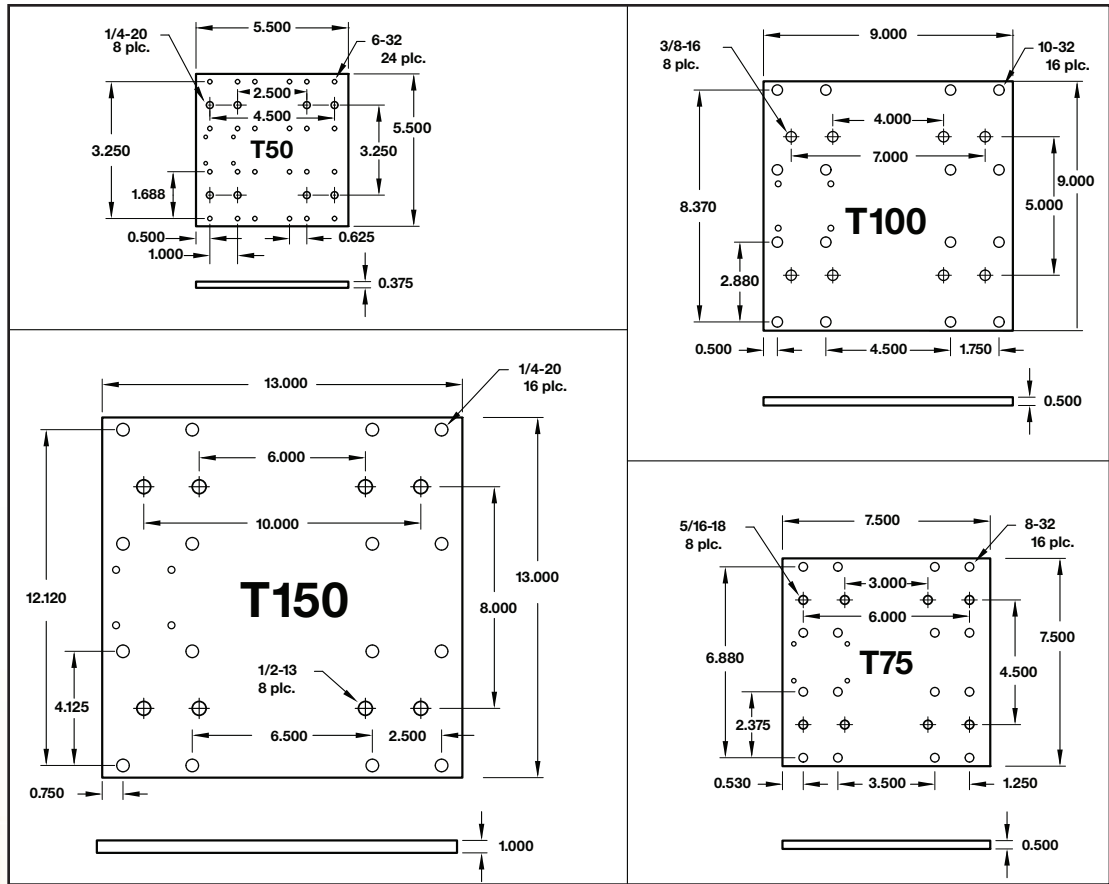

SHAFT END STOPS

For shafts that have drilled and tapped ends, consider mounting LEE LINEAR® Shaft End Stops to prevent linear bearings from running off the shaft ends. LEE LINEAR® Shaft End Stops consist of a stop washer, lock washer, and socket head cap screw, and are offered in five sizes.

PART NO.	SHAFT DIA.	[C] BOLT SIZE	[D] O.D.	[T] THICKNESS	(H)
ES08	1/2	1/4	1.250	1/16	5/16
ES12	3/4	3/8	1.500	1/16	7/16
ES16	1	7/16	2.000	7/64	1/2
ES24	1-1/2	1/2	2.750	1/8	9/16
ES32	2	1/2	3.000	1/8	9/16

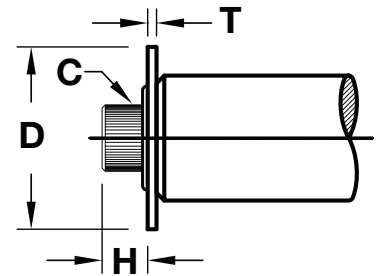

BELLOWS

Keep contamination in check with LEE LINEAR® Bellows. Made for slide tables or systems, LEE LINEAR® Bellows protect shafts from particulates that will shorten the travel life. Contact factory for specific availability.



LINEAR CARRIAGE LOCK

The Linear Carriage Lock is a positive locking device for linear slides, carriages, and bearings.

The Locks are:

- Self-centering
- Corrosion resistant
- Strong holding
- Contaminant resistant
- Easily mounted
- Maintenance free

LINEAR CARRIAGE LOCK TABLE

CARRIAGE LOCK SIZE	SHAFT DIA.	D	B	C	J	F	H	S
8	1/2	0.920	2.00	1	0.220	0.810	0.690	0.260
12	3/4	1.250	2.75	1	0.220	0.810	0.940	0.260
16	1	1.600	3.25	1	0.270	0.810	1.180	0.260
24	1-1/2	2.290	4.75	1	0.400	0.810	1.750	0.260
32	2	2.850	6.00	1	0.500	1.250	2.130	0.500

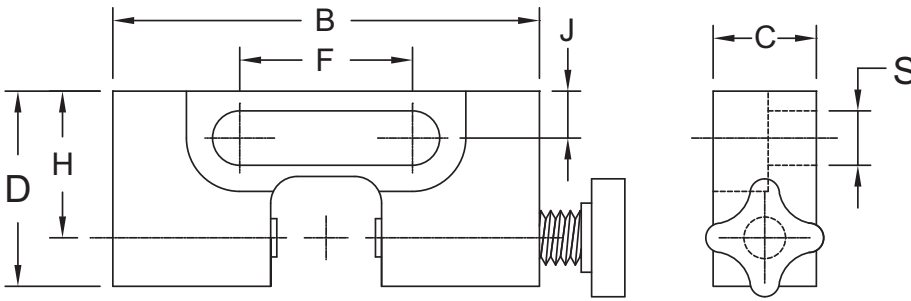

MOTOR MOUNTING BLOCKS (NEMA MOUNTS)

LEE LINEAR® Motor Mounting Blocks come in three different models that accommodate NEMA-23, NEMA-34, and NEMA-42 configurations. LEE LINEAR® Motor Mounting Blocks are made from T6 tempered aluminum and can be ordered with an optional black anodized finish.

PART NO.	MOTOR SIZE	W2	W3	H2	H3	D2	D3	L2
MB08	NEMA 23	2.240	2.240	2.240	1.860	1.503	2.149	1.030
MB16	NEMA 34	3.260	3.260	3.375	2.740	2.878	2.875	1.590
MB24	NEMA 42	4.380	4.380	4.380	3.500	2.189	4.100	2.000

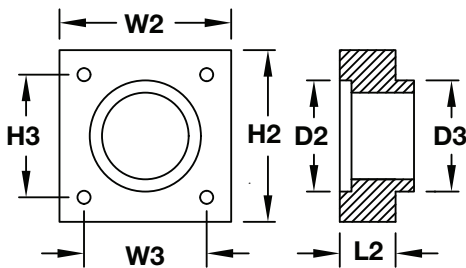

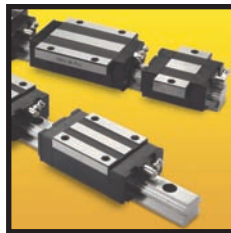
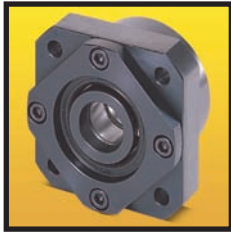
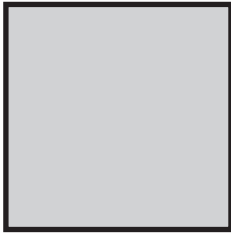
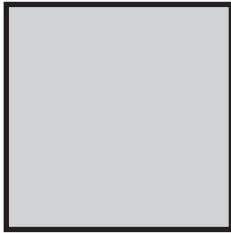
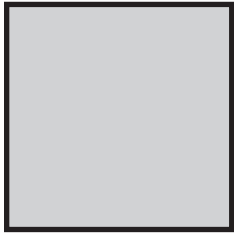
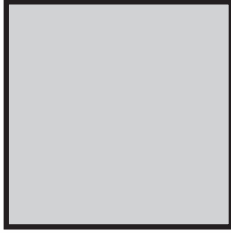
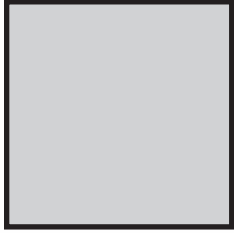
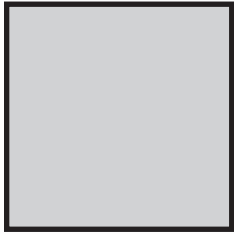

727 South Avenue
 Piscataway, New Jersey 08854
 Toll-Free: (800) 221-0811
 Fax: (732) 968-7080 Phone: (732) 752-5200
 Email: leelinear@linearmotion.com
 2008

www.leelinear.com

