

# Koyo<sup>®</sup>

## Cylindrical Roller Bearings for the Backing Shafts of Multi-roll Mills

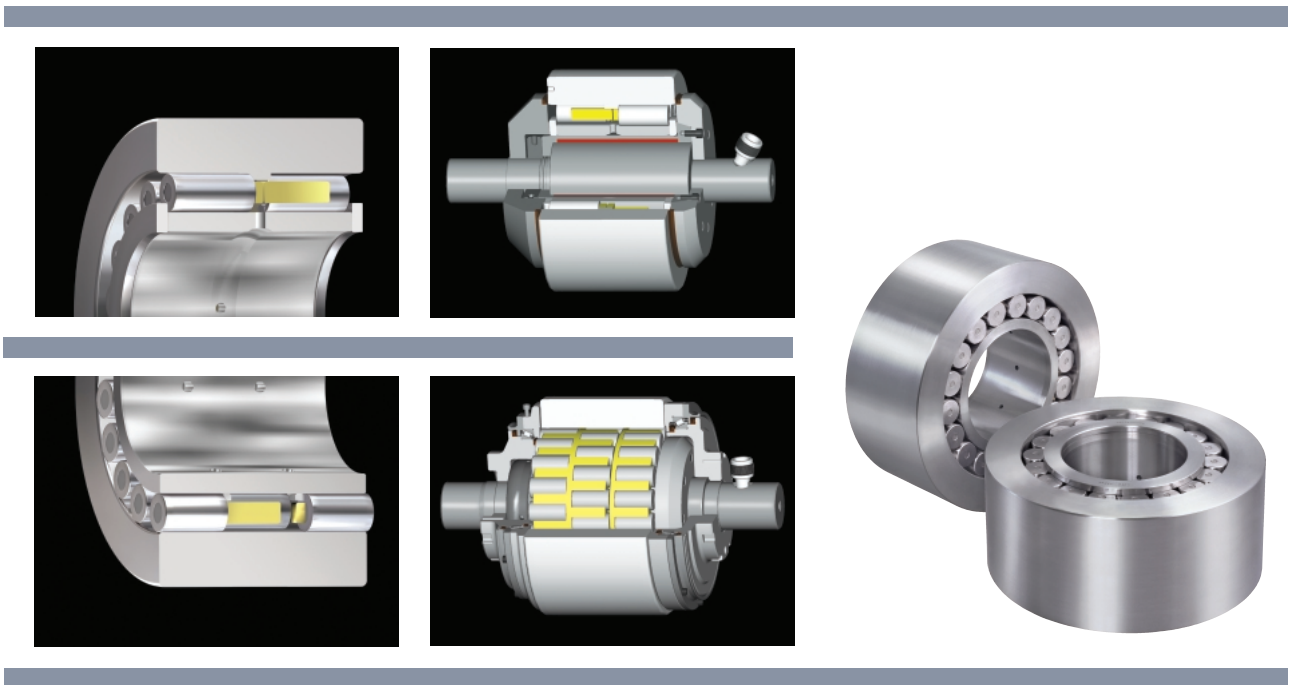

**KOYO SEIKO CO., LTD.**

CAT.NO. 246E

# Cylindrical Roller Bearings for the Backing Shafts of Multi-roll Mills

## 1. Introduction

Based on many years of experience and recorded success in the area of multi-roll mills, Koyo supplies high-durability, high-precision cylindrical roller bearings for backing shafts.

Koyo also supplies regrinding jigs that can grind the outside diameter surface of the bearings with exact precision.



Fig. 1 Cylindrical Roller Bearings for the Backing Shafts of Multi-roll Mills

**Koyo satisfies all needs specific to cylindrical roller bearings for backing shafts.**

- More durable outer ring
- Inner ring with longer rolling fatigue life
- Outer ring with higher running accuracy after regrinding
- More efficient outer ring regrinding

**Koyo has solutions to your needs.**

## Contents

1. Introduction .....	1
2. Construction and Advantages of Koyo Bearings .....	2
3. Regrinding Jigs for Bearings for Backing Shafts .....	3
4. Measurement for Bearing Section Height .....	4
5. Dimension Tables .....	5
6. Varieties of Multi-roll Mills and Their Roll Arrangements .....	9

### 2. Construction and Advantages of Koyo Bearings

On each backing shaft of a multi-roll mill, several bearings are installed side by side. With their outside diameter surfaces in direct contact with the intermediate rolls, these bearings rotate while carrying components of rolling force. Therefore, the outer rings of these bearings are required to have adequate rigidity and fatigue strength, and should be finished with high precision.

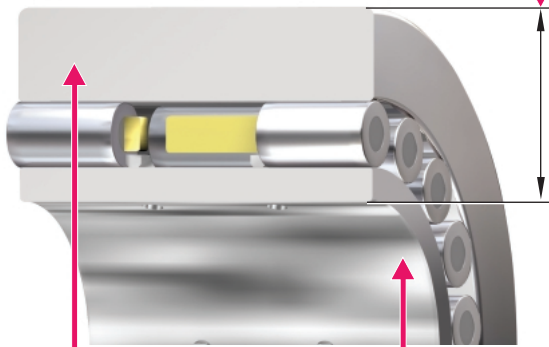

**Fig. 2 Bearing Construction**

- The outer rings of Koyo bearings for backing shafts are made from a newly developed steel material, processed by Koyo's original cored hardening treatment. Compared with carburized steel, this newly developed steel has the following advantages:

- The suitably soft core ensures superior impact resistance.
- The thick hardened surface layer ensures high rigidity and provides the outside diameter surface with an increased regrinding allowance.
- The excellent material composition realizes high fatigue strength.

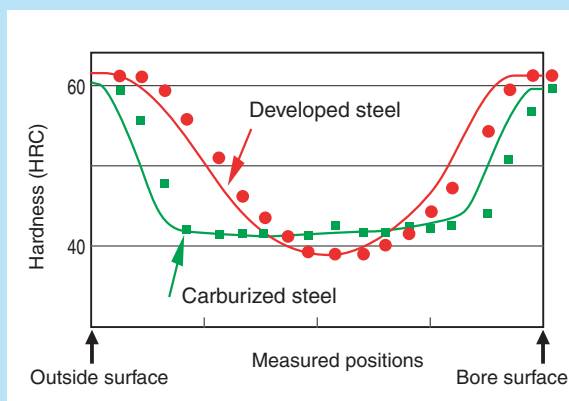

**Fig. 3 Typical Hardness Distribution of cored hardening Outer Ring**



**Fig. 4 Macroscopic Material Composition**

\* The cored hardening treatment is applicable to bearings of no less than 130 mm in bore diameter.

- The bearing section height and running accuracy of Koyo's precision produced bearings realize optimal load distribution, contributing to the improved precision of rolled products.
- The outside diameter surfaces of these bearings are crowned, preventing load concentration at the ends and thus protecting the intermediate rolls from damage.

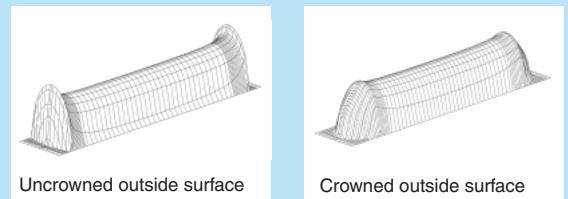

**Fig. 5 Typical Contact Stress Distribution of Outer-ring Outside Surface**

- The inner ring can be selected from between one made from highly refined steel (HRS), which features long rolling fatigue life, or one processed by special heat treatment (SH2), which features high wear resistance and long service life even under lubrication conditions susceptible to the ingress of foreign particles.

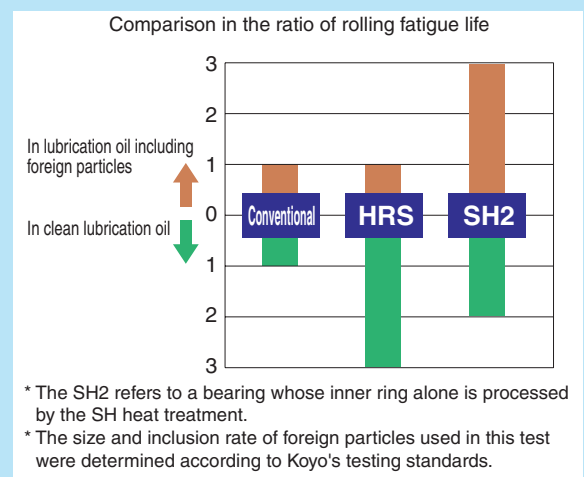

\* The SH2 refers to a bearing whose inner ring alone is processed by the SH heat treatment.  
 \* The size and inclusion rate of foreign particles used in this test were determined according to Koyo's testing standards.

**Fig. 6 Comparison of Long-life Materials in Service Life**

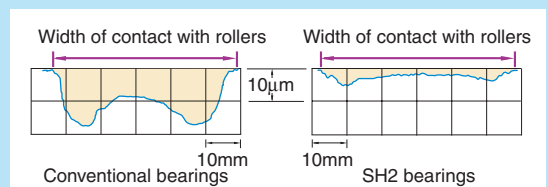

**Fig. 7 Comparison between Conventional Bearings and SH2 Bearings in Wear (Inner ring raceway surface after 1 600 hours' use)**

### 3. Regrinding Jigs for Bearings for Backing Shafts

#### Overview

The outside diameter surfaces of the bearings used on the backing shafts of multi-roll mills should be ground periodically to retain precise bearing performance, thus ensuring the quality of rolled products. Koyo supplies the jigs that grind bearing's outside diameter surface with high precision.

#### Advantages

##### 1 The jigs minimize the radial runout of the bearings.

Once the bearing is installed into the jig, the jig completely nullifies any clearance on the fitting surface between the jig and bearing and the internal clearance of the bearing, eliminating play in the radial direction. The jig grinds the outside diameter surface while turning the outer ring and retaining the inner ring as stationary, enabling grinding under the same conditions as when in operation.

##### 2 The jigs improve efficient installation and removal.

Bearings can be installed on and removed from the jig easily without the need of disassembling the inner ring and outer ring. There is no possibility that rollers will come off.



Fig. 8 Bearing-regrinding Jig

#### Jig Types and Constructions

The jigs come in two types, which should be selected according to the dimensions and types of backing-shaft bearings. Please specify the type suitable to your needs.

##### ■ Type 1

This type is suitable to bearings with the outer ring with ribs and with a bore diameter no less than 70 mm. This jig requires holes for work carrier on the end face of the outer ring.

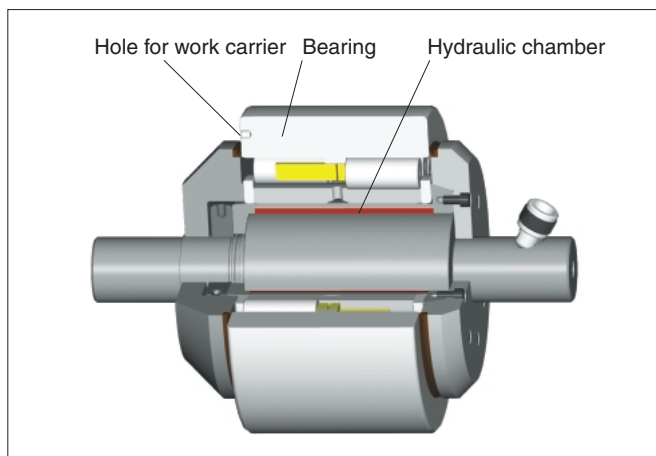

Fig. 9 Typical Installation of Suitable Bearing on Jig Type 1

##### ■ Type 2

This jig is suitable with bearings with the outer ring without ribs, such as those used on the Sendzimir Rolling Mills ZR21 and ZR22.

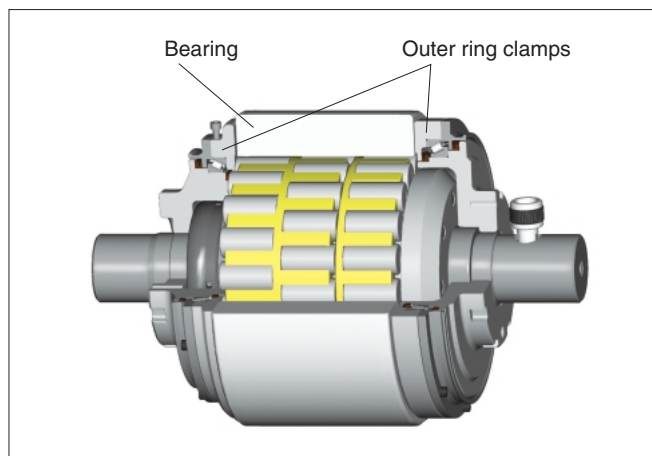

Fig. 10 Typical Installation of Suitable Bearing on Jig Type 2

### 4. Measurement for Bearing Section Height

#### Overview

When the outside diameter surface of a bearing is ground, it is critical to accurately control the variation of bearing section heights of all the bearings installed on the backing shaft. Koyo supplies Measurement for bearing section height that suit the individual bearings listed on the dimensional table.

#### Advantages

- 1 These bearing section height measurements are highly rigid and perform extremely precise measurement.
- 2 These measurements can measure the running accuracy of the outer rings as well.
- 3 For easy bearing installation and removal, the measurements are arbor-shaped.



Fig. 11 Measurement for Bearing Section Height

### Reference information

Koyo can supply the bearings listed in the dimensional table such that they can be assembled on the backing shaft so as to satisfy the bearing section height tolerances shown below:

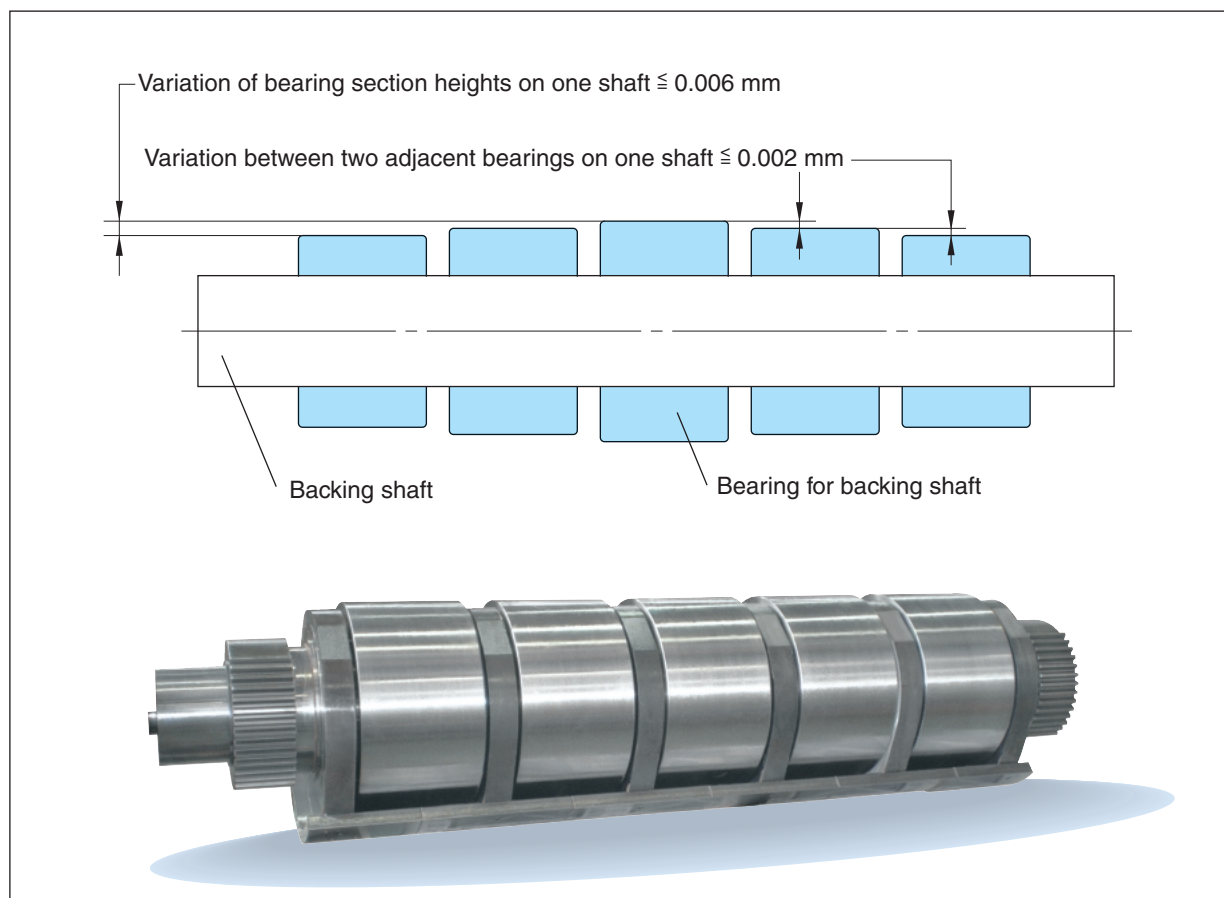

## 5. Dimension Tables

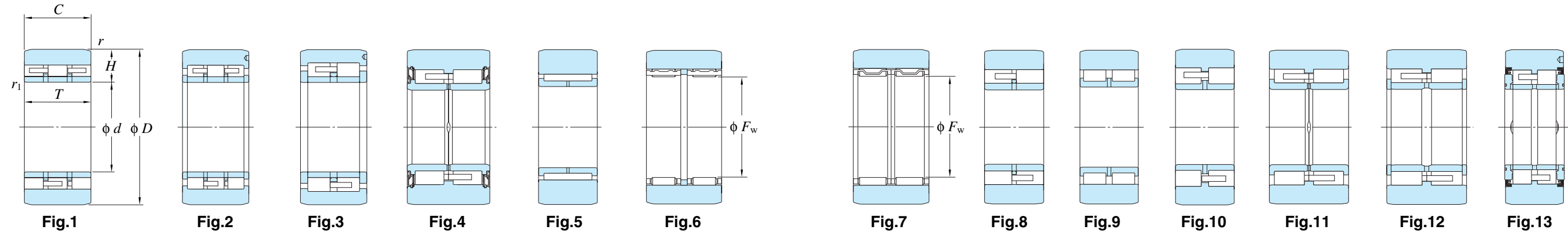

Boundary dimensions (mm)						Basic load rating (kN)		Bearing number	Fig.	Bearing section height at the time of manufacture (mm) <i>H</i>	Mass (kg)	Compatible Rolling Mill Model	Number of bearings used per mill <sup>1)</sup>
<i>d</i> ( <i>F<sub>w</sub></i> )	<i>D</i>	<i>T</i>	<i>C</i>	<i>r</i>	<i>r</i> <sub>1</sub>	<i>C</i> <sub>r</sub>	<i>C</i> <sub>0r</sub>						
(18)	35	–	46	0.5	–	33.8	52	04DC04046ADS	6	8.4875	0.225	Z-High	24
(25)	45	–	45	0.8	–	35.3	59.3	05DC05045ADS	6	9.9875	0.350	Z-High	64
(28)	48	–	55	0.8	–	44.5	93.3	06DC05055BDS	7	9.9875	0.468	Z-High	128
(28)	54	–	55	0.8	–	44.5	93.3	06DC05055DS	7	12.9875	0.677	Z-High	64
31.75	76.2	46.23	45.85	0.8	1.5	96.3	183	06DC0846A	9	22.200	1.27	ZR34	40
(38)	65	–	60	0.8	–	64.4	145	08DC07060DS	7	13.4875	0.961	Z-High	72
(45)	85	–	55	0.8	–	59.1	160	09DC09055DS	7	19.9925	1.69	Z-High	128
50	120	80	80	1.5	1.5	268	379	10DC1280DS	3	34.976	5.15	KT	32
50	120	85	85	1.5	1.5	303	427	10DC1285DS	3	34.984	5.40	KT	32
54.999	120	25.999	25.999	1.6	1.6	77.7	138	11N1226V	13	32.4672	1.69	ZR24	24,56
55	120	52.197	52	1.6	1.6	203	341	11DC1252	9	32.483	3.27	ZR24	40
60	160	95	95	1.5	2	398	589	12DC1695DS	3	46.484	11.5	KT	(20)
62	155	90	90	1	2	356	529	12DC1690DS	3	46.484	9.97	KT	(8)
62	155	110	110	1	2	404	622	12DC16110DS	2	46.484	12.2	KST	(34)
65	165	70	70	1.5	2	424	586	13DC1770DS	10	49.982	8.83	Sundwig	40
65	170	100	100	2	2	398	597	13DC17100DS	3	52.480	13.5	KT	30
70	160	90	90	1.5	1.5	347	546	14DC1690LDS-1	11	44.977	10.1	ZR33	40
70	160.07	90	90	1.5	1.5	379	667	14DC1690ADS	1	45.000	10.5	ZR33	32,48,72
90	220	94	94	2	1.5	687	997	18DC2294DS	10	64.976	21.2	Sundwig	40
90	220	96	94	3	3	494	700	18DC2294/96DS	5	65.000	21.0	Sundwig	64
90	220	95	95	2	2	532	795	18DC2295DS	3	64.982	20.9	KST	40
90	220	130	130	2	2	699	1130	18DC22130ADS	2	64.982	28.7	KST	32,40
90	230	100	100	2	3	643	982	18DC23100DS	3	69.980	24.2	KT	(24)
90	260	125	125	2	2	923	1520	18DC26125DS	3	84.970	41.3	KT	34

Note 1) Parenthesized numbers indicate that the bearings of different numbers are also used.

## 5. Dimension Tables

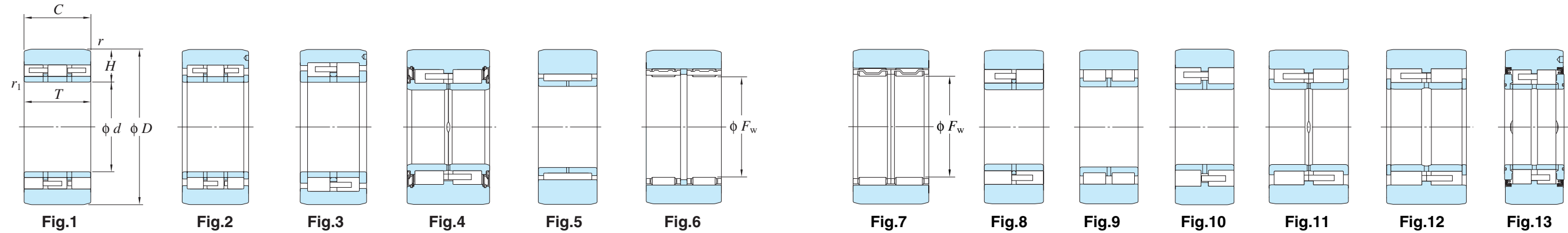

Boundary dimensions (mm)						Basic load rating (kN)		Bearing number	Fig.	Bearing section height at the time of manufacture (mm) <i>H</i>	Mass (kg)	Compatible Rolling Mill Model	Number of bearings used per mill <sup>1)</sup>
<i>d</i> ( <i>F<sub>w</sub></i> )	<i>D</i>	<i>T</i>	<i>C</i>	<i>r</i>	<i>r</i> <sub>1</sub>	<i>C<sub>r</sub></i>	<i>C</i> <sub>or</sub>						
100	225.021	80	80	1.5	1.5	607	991	20DC23080DS	8	62.474	18.2	ZR23	(8),(12)
100	225	100	100	3	1.5	547	838	20DC23100NDS-1	11	62.480	21.7	ZR23	40
99.995	225	120	120	1.5	1.5	625	995	20DC23120KDS-2	4	62.474	26.0	ZR23	32,40,48
100	225	120	120	3	1.5	663	1070	20DC23120NDS-1	11	62.480	26.2	ZR23	-
100	225	120	120	3	1.5	676	1100	20DC23120LDS-1	12	62.4775	26.3	ZR23	32,48,56
100	225.021	120	120	3	3	714	1350	20DC23120DS	1	62.474	27.5	ZR23	32
100	225.021	120	120	1.5	1.5	814	1440	20DC23120MDS	1	62.474	27.2	ZR23	32
100	260	95	95	2	2	698	1060	20DC2695DS	3	79.970	30.2	KT	32
100	260	105	105	2	2	710	787	20DC26105DS	3	79.970	33.5	KT	32
100	260	130	130	2	2	952	1580	20DC26130DS	3	79.970	41.5	KT	32
100	260	130	130	2	2	846	1290	20DC26130ADS	5	79.970	41.0	KT	-
110	280	165	165	2	2	1120	1880	22DC28165DS	2	84.965	60.2	KT	(10)
115	260	140	140	3	2	976	1690	23DC26140DS	2	72.470	41.9	KST	40
120	280	165	165	2	3	1100	1940	24DC28165DS	3	79.965	57.7	KT	14
120	300	160	160	2	3	1240	2100	24DC30160DS	2	89.966	66.8	KT	-
120	350	165	165	2	3	1370	2220	24DC35165ADS	12	114.965	98.3	KT	(24)
130	300.02	130	129	2	3	1050	1740	26DC30130DS	3	85.010	52.2	Sundwig	56
130	300.02	130	129	4	3.5	980	1530	26DC30130ADS	5	85.010	51.4	Sundwig	-
130	300.02	132	129	2	3	1050	1740	26DC30132DS	3	85.010	53.0	Sundwig	72
130	300	160	159.5	4	3.5	1330	2340	26DC30160DS	1	84.9617	64.8	ZR22	40,48
130	300	160	159.5	5	3.5	1210	2070	26DC30160JDS	12	84.955	64.2	ZR22	-
130	300	172.644	172.644	4	3.5	1450	2610	26DC30170DS	1	84.955	70.6	ZR22	40,48
130	300	172.644	172.644	4	3.5	1560	2900	26DC30170MDS-5	1	84.955	72.6	ZR22	40,48
130	300	172.644	172.644	4	3.5	1320	2330	26DC30170NDS-3	11	84.955	69.2	ZR22	48
130	300	172.644	172.644	4	3	1360	2410	26DC30170PDS-2	12	84.955	69.6	ZR22	40,48
130	300	172.644	172.644	4	3.5	1240	2150	26DC30170KDS	4	84.955	68.5	ZR22	40,48
130	350	175	175	2	3	1400	2300	26DC35175DS	12	109.965	101	KT	-
180	406.42	171.04	171.04	4	4	2060	3810	36DC41171DS	1	113.155	130	ZR21	48,56
180	406.42	171.04	171.04	4	1	1910	3340	36DC41171ADS	12	113.155	124	ZR21	48,56
180	406.42	171.04	171.04	4	3	1550	2700	36DC41171KDS	4	113.155	121	ZR21	48
180	406.4	217	217	4	3.5	2450	4760	36DC41217-2DS	1	113.160	160	ZR21	48
179.984	406.43	223.96	217	4	0.5	2350	4500	36DC41217DS+DP	1	113.155	161	ZR21	40,48
179.984	406.43	224.25	220	3	3	2160	4050	36DC41224MDS	11	113.181	162	ZR21	32,48
179.984	406.43	224.25	220	4	3	1870	3340	36DC41224KDS	4	113.181	150	ZR21	32,48
180	406.42	224.25	224	4	1	2360	4390	36DC41224PDS	12	113.155	164	ZR21	40,48

Note 1) Parenthesized numbers indicate that the bearings of different numbers are also used.

## 6. Varieties of Multi-roll Mills and Their Roll Arrangements

### ZR..

Sendzimir  
20-High Mill

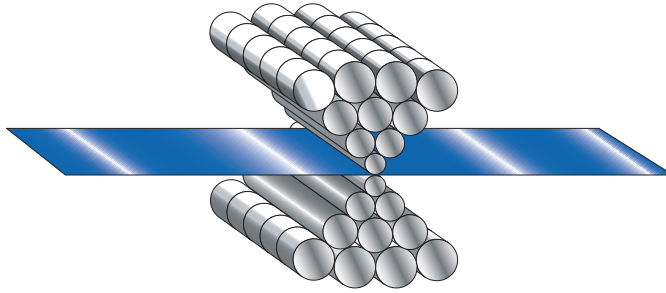

### Z-High

Sendzimir  
Z-High Mill

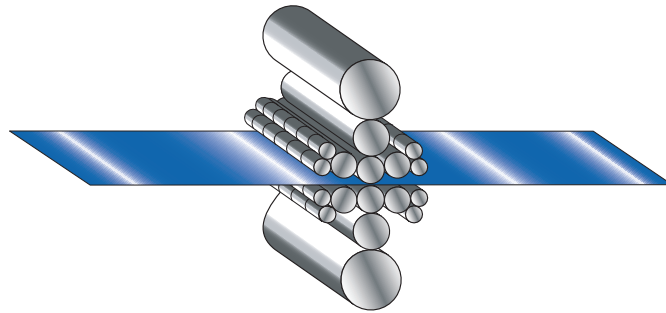

### KST

KOBELCO  
KST Mill

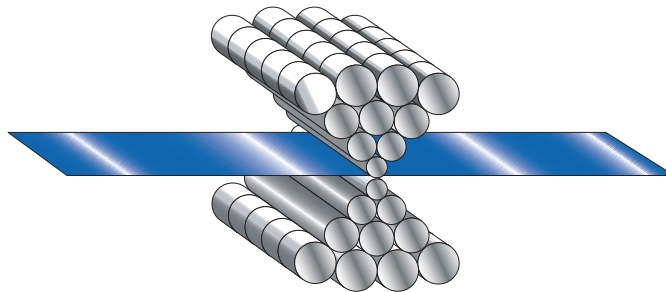

### KT

KOBELCO  
KT Mill

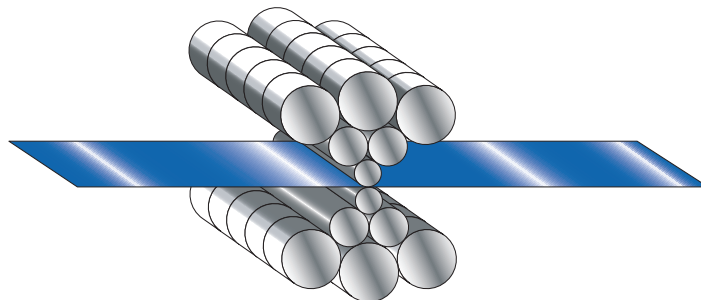

### Sundwig

Sundwig  
20-High Mill

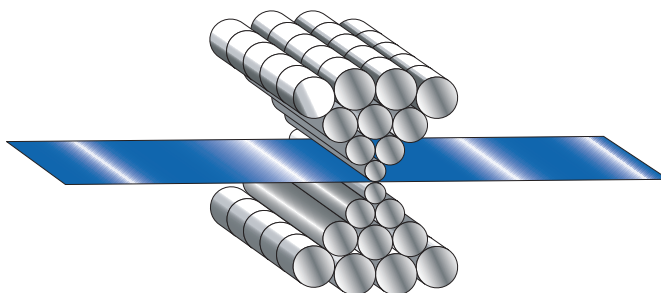



# INTERNATIONAL NETWORK

## \* KOYO SEIKO CO., LTD. HEAD OFFICE

No.5-8, Minamisemba 3-chome, Chuo-ku, Osaka 542-8502, JAPAN  
TEL : 81-6-6245-6087  
FAX : 81-6-6244-0814  
TLX : 63040(KOYO OSJ)

## OFFICES

### KOYO CANADA INC.

5324 South Service Road, Burlington, Ontario L7L 5H5, CANADA  
TEL : 1-905-681-1121  
FAX : 1-905-681-1392

### \*\*\* KOYO CORPORATION OF U.S.A.

#### -Cleveland Office-

29570 Clemens Road, P.O.Box 45028 Westlake,  
OH 44145, U.S.A.  
TEL : 1-440-835-1000  
FAX : 1-440-835-9347  
TLX : 0985461(AMKOY RKVR)

#### -Detroit Office-

47771 Halyard Drive, Plymouth, MI 48170, U.S.A.  
TEL : 1-734-454-1500  
FAX : 1-734-454-4076

### \*\*\* KOYO STEERING SYSTEMS OF U.S.A. INC.

47771 Halyard Drive, Plymouth, MI 48170, U.S.A.  
TEL : 1-734-454-7067  
FAX : 1-734-454-7059

### KOYO MÉXICANA, S.A. DE C.V.

Av.Primer de Mayo No.153, 53500 Naucalpan  
Edo.de México, MÉXICO  
TEL : 52-55-5358-0077/0214  
FAX : 52-55-5576-8827/8871

### \*\* KOYO LATIN AMERICA, S.A.

P.O.Box 6-1797, El Dorado, Panama, REPUBLICA DE PANAMA  
TEL : 507-264-0921/0977  
FAX : 507-264-2782/507-269-7578

### KOYO ROLAMENTOS DO BRASIL LTDA.

Rua Desembargador Eliseu Ghilherme 304, 7-Andar,  
Paraiso CEP 04004-30, BRASIL  
TEL : 55-11-3887-9173  
FAX : 55-11-3887-3039

### THAI KOYO CO., LTD.

172 Moo 12 Tambol Bangwua, Amphur Bangpakong,  
Chachoengsao 24180, THAILAND  
TEL : 66-38-533-310-7  
FAX : 66-38-532-776

### KOYO SINGAPORE BEARING (PTE.) LTD.

38 Tuas West Road, Singapore 638385, SINGAPORE  
TEL : 65-6274-2200  
FAX : 65-6862-1623

#### -India Office-

1104,GD-ITL Tower,B-08, NETAJI SUBHASH PLACE,PITAM PURA,  
DELHI 110034 INDIA  
TEL : 91-11-2715-3502~04  
FAX : 91-11-2715-3501

### PHILIPPINE KOYO BEARING CORPORATION

Rm.504, Comfoods Bldg., Cor. Gil Puyat Ave. and  
Pasong Tamo, Makati City, PHILIPPINES  
TEL : 63-2-817-8881/8901  
FAX : 63-2-867-3148

### KOYO KOREA CO., LTD.

Inwoo Building 6F, 539-11, Shinsa-Dong,  
Kangnam-Ku, Seoul, KOREA  
TEL : 82-2-549-7922  
FAX : 82-2-549-7923

### KOYO SEIKO CO., LTD. BEIJING LIAISON OFFICE

Room 809, Jingtai Tower, 24 Jianguomenwai Street, Beijing,  
100022, CHINA  
TEL : 86-10-6515-0037  
FAX : 86-10-6515-0522

### KOYO (SHANGHAI) CO., LTD.

Rm.402, Aetna Tower, 107 Zunyi Road, Shanghai 200051, CHINA  
TEL : 86-21-6237-5280  
FAX : 86-21-6237-5277

### KOYO SEIKO CO., LTD. SHANGHAI LIAISON OFFICE

Orient International Tower A-1303, 85 Loushanguan RD. Shanghai,  
200336 CHINA  
TEL : 86-21-6237-5280  
FAX : 86-21-6237-5277

### \*\* KOYO AUSTRALIA PTY. LTD.

P.O.Box 442, Rydalmere, 2116 N.S.W., AUSTRALIA  
TEL : 61-2-9638-2355  
FAX : 61-2-9638-3368

### \* KOYO SEIKO CO., LTD. EUROPEAN CENTRAL OFFICE

Markerkant 13-01, 1314 AN Almere, THE NETHERLANDS  
TEL : 31-36-5383333  
FAX : 31-36-5347212

### \* KOYO KULLAGER SCANDINAVIA A.B.

Johanneslundsvagen 4 194 61 Upplands Väsby, SWEDEN  
TEL : 46-8-594-212-10  
FAX : 46-8-594-212-29

### \* KOYO STEERING EUROPE S.A.S.

Zone Industrielle du Broteau, B.P.1, 69540 Irigny, FRANCE  
TEL : 33-472-39-4444  
FAX : 33-472-39-2188

### \* KOYO (U.K.) LTD.

Whitehall Avenue, Kingston, Milton Keynes MK10 OAX,  
UNITED KINGDOM  
TEL : 44-1908-289300  
FAX : 44-1908-289333

### \* EUROPA-KOYO B.V.

P.O.Box 1-2965 ZG, Nieuwpoort, THE NETHERLANDS  
TEL : 31-184-606800  
FAX : 31-184-602572/606857

### KOYO ROMANIA REPRESENTATIVE OFFICE

Str. Frederic Jolliot-Curie, Nr.3, Etaj 1, Ap.2, Sector 5  
Bucharest, ROMANIA  
TEL : 40-21-410-4170/4182/0984  
FAX : 40-21-410-1178

### \* KOYO DEUTSCHLAND GMBH.

P.O.Box 73 06 60, D-22126 Hamburg, GERMANY  
TEL : 49-40-67-9090-0  
FAX : 49-40-67-9203-0  
TLX : 213138(KOYO D)

### \* KOYO FRANCE S.A.

8 Rue Guy Moquet, B.P.189 Z.I., 95105 Argenteuil Cedex, FRANCE  
TEL : 33-1-3998-4202  
FAX : 33-1-3998-4244/4249

### \* KOYO IBERICA, S.A.

Avda.da la Industria, 52-2 izda 28820  
Coslada Madrid, SPAIN  
TEL : 34-91-329-0818  
FAX : 34-91-747-1194

### \* KOYO ITALIA S.R.L.

Via Bronzino 9, 20133 Milano, ITALY  
TEL : 39-02-2951-0844  
FAX : 39-02-2951-0954

( KOYO SEIKO CO., LTD. (Japan) is certified to ISO/TS16949, ISO9001 and QS-9000. )  
\*:ISO/TS16949 certified. \*\*:ISO9001 certified. \*\*\*:QS-9000 certified.

★The contents of this catalog are subject to change without prior notice.  
Every possible effort has been made to ensure that the data listed in this catalog is correct.  
However, we can not assume responsibility for any errors or omissions.

Reproduction of this catalog without written consent is strictly prohibited

# Cylindrical Roller Bearings for the Backing Shafts of Multi-roll Mills

Value & Technology

