

KAYDON

TURNING IDEAS INTO ENGINEERED SOLUTIONS



Worm Drive Rotation Systems

Pre-tested, compact rotators for light- to medium-duty applications

- Aerial baskets
- Small cranes
- Work platforms
- Truck mounted cranes
- Work positioners
- Fixture tables

KAYDON/BEARINGS

Choose Kaydon pre-engineered worm drive rotation systems for reliability, simplicity, and compactness

Why endure the hassle of building rotating units yourself from components supplied by a variety of vendors, when you can save time and money with completely assembled systems from Kaydon?

At Kaydon, we machine our own turntable bearings and worm gears to exacting standards, then assemble, pre-lubricate, and test the units to ensure rotational precision and reliability.

More efficient design saves you money

This compact design saves space and lowers component costs. Hydraulic or electric motors mount directly to the Kaydon worm drive system potentially eliminating additional gear boxes, pinions, or braking systems. And all maintenance can be carried out from outside of the assembly.

Pre-tested and run-in to ensure mesh compatibility

Manufacturing and assembling the components that go into our worm drive systems is only the beginning. At Kaydon

we offer an important advantage you won't find anywhere else—thorough pre-testing and run-in of every unit prior to shipment. That means you'll never have to tear down a newly assembled piece of equipment to repair or replace a worm drive that doesn't mesh.

Rotation systems sized for a variety of equipment needs

Kaydon offers several sizes, each engineered for ease of installation, superior operating performance, and long life. All units feature a pre-lubricated sealed turntable bearing and worm with provisions for regreasing, a manually operable hex drive to permit emergency repositioning, and an SAE Type A two-bolt motor mount for a 1" keyed shaft. Single and non-enveloping gearing options are available.

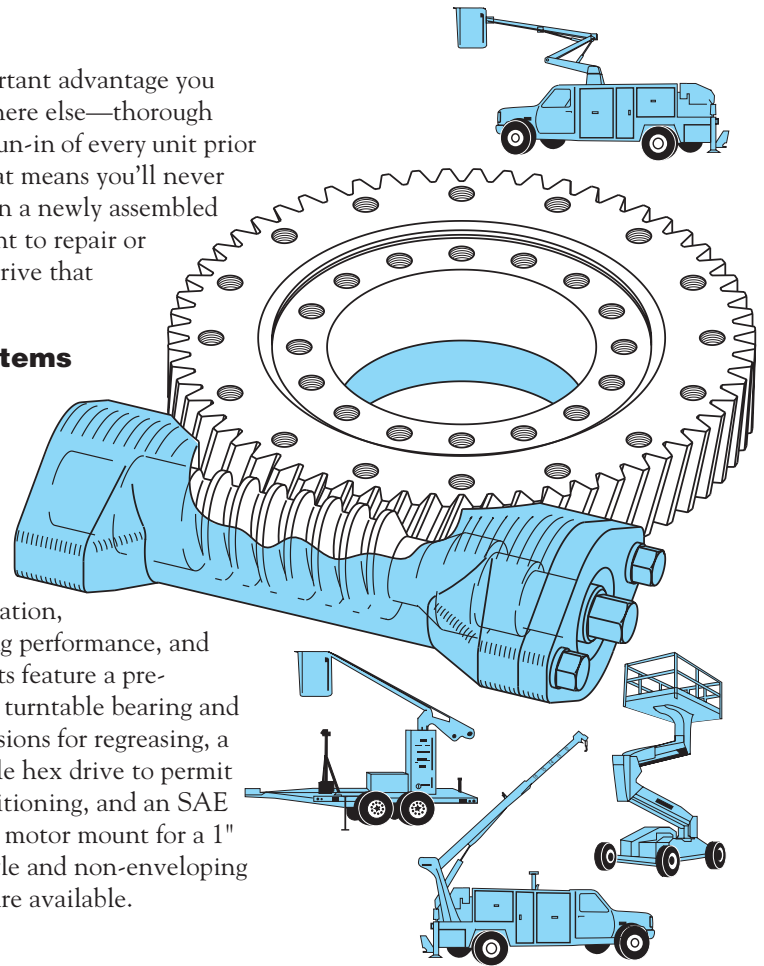

Small

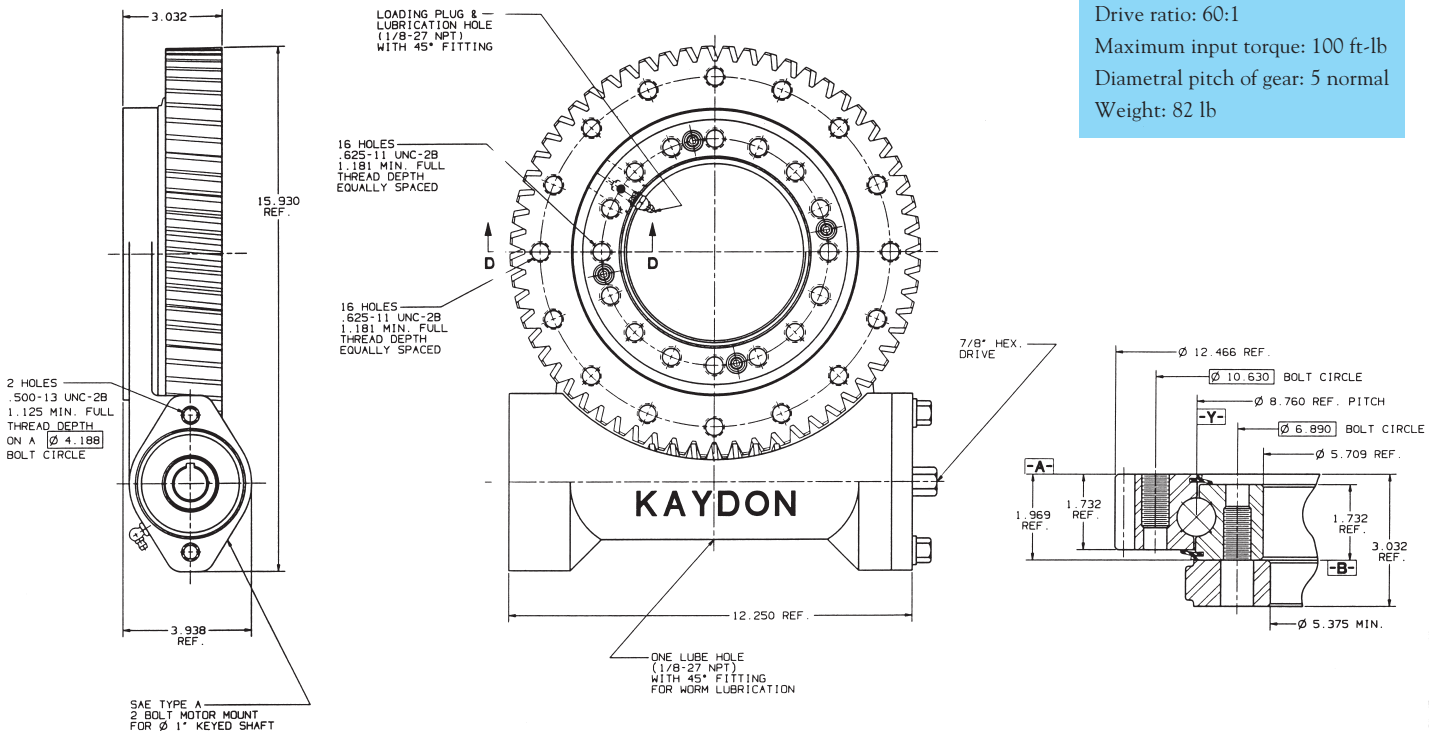

Medium

Drive ratio: 85:1
 Maximum input torque: 100 ft-lb
 Diametral pitch of gear: 5.08
 Weight: 125 lb

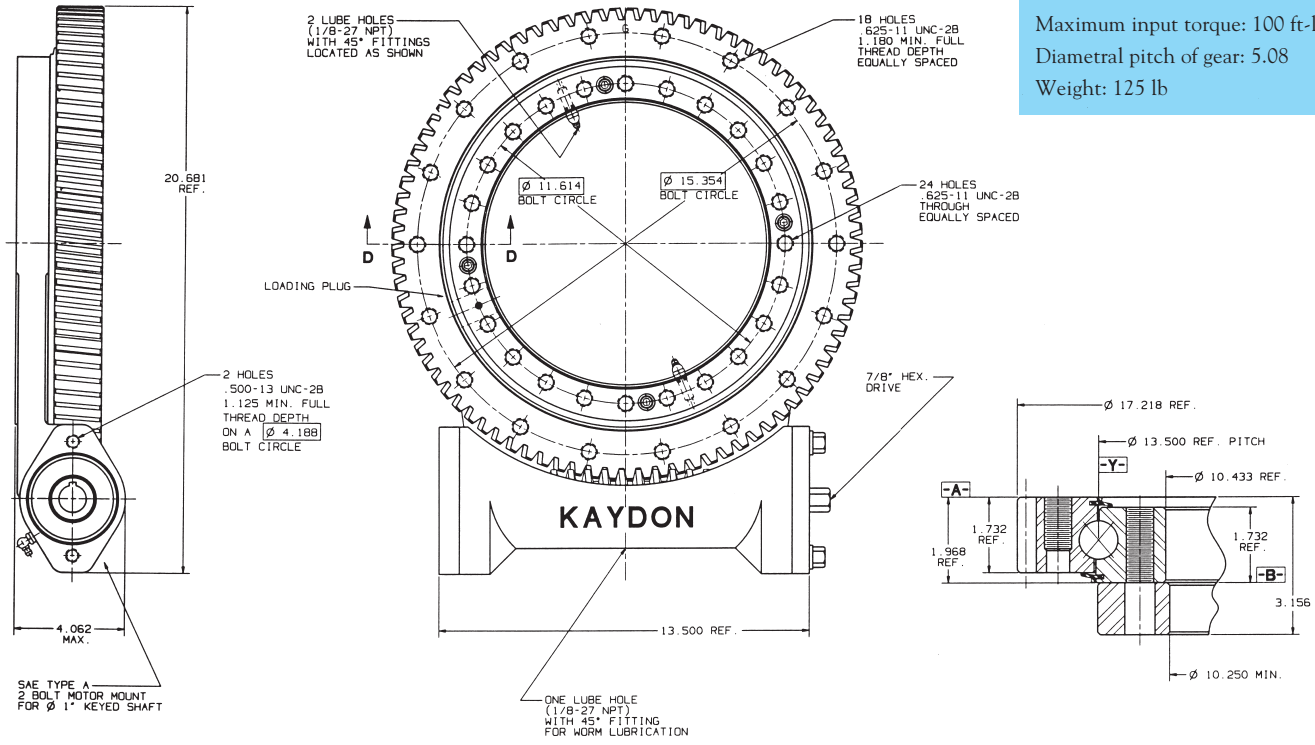

Large

Drive ratio: 103:1
 Maximum input torque: 150 ft-lb
 Diametral pitch of gear: 5.025
 Weight: 215 lb

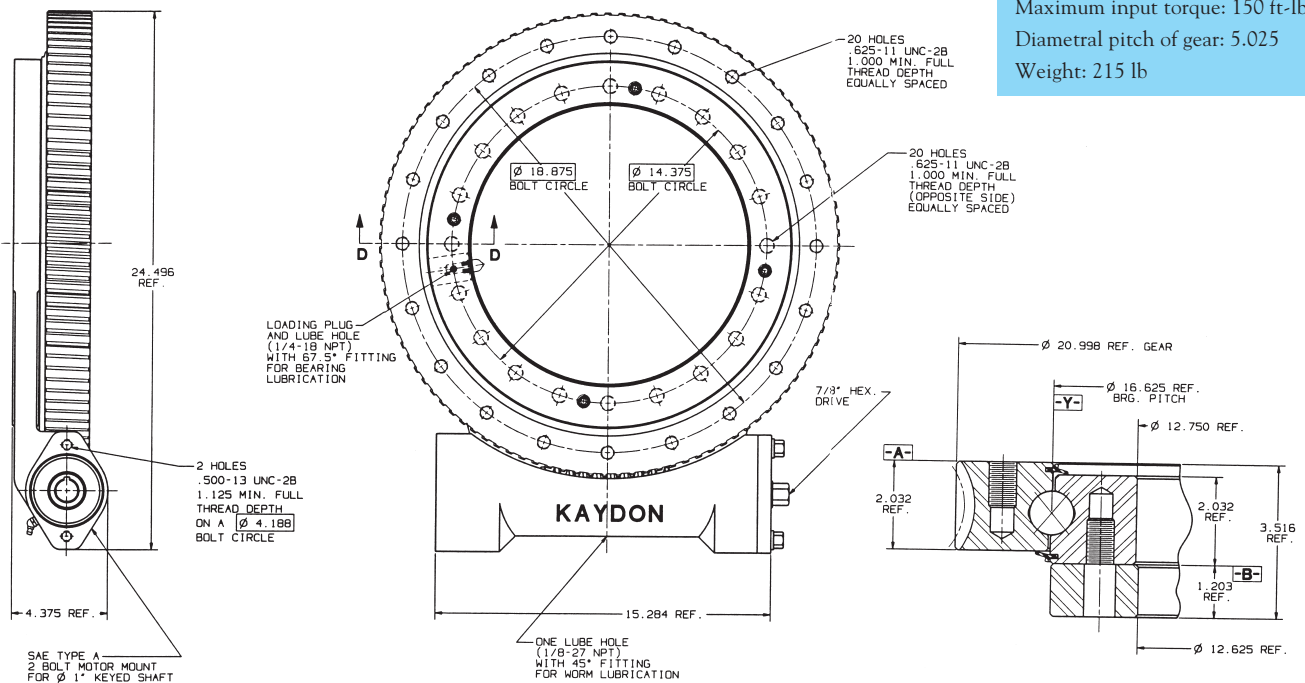

Features of Kaydon worm drive rotation systems

- Wide application—industrial—commercial—farm equipment. Aerial baskets, small cranes, work platforms, truck-mounted cranes, work positioners, index tables, fixture tables
- Compact design saves space
- 4-point contact turntable bearing with fully hardened ball paths and high-grade alloy chrome steel balls
- Hardened steel worm gear
- Hex drive manual repositioner
- SAE Type A two-bolt motor mount for 1" keyed shaft
- All units pre-tested and run-in
- Available in three sizes
- A “best buy” in slew drives

Free application assistance

The power transmission equipment design experts at Kaydon can help you select the worm drive that will best meet the requirements of your application. For a free consultation, call 1-800-514-3066.

Warranty: Kaydon Corporation guarantees its products to be free from defects in materials and workmanship for a period of one year from date of shipment from our plant. Any product proving defective within this one year period will be replaced free of charge provided the defective product is returned, charges prepaid and is found to have been properly mounted, lubricated, loaded, and used. No responsibility will be assumed by Kaydon for contingent charges.

KAYDON CORPORATION

2860 McCracken Street
Muskegon, Michigan 49443 U.S.A.

3 Corporate Circle
Sumter Industrial Complex
Sumter, South Carolina 29154 U.S.A.

1-800-514-3066 • Fax: 616/759-4102

