



the power of
EPT

KOP-FLEX®
*Turbomachinery
Coupling
Catalog*



EMERSON.
Industrial Automation

EMERSON. CONSIDER IT SOLVED.®

KOP-FLEX® Couplings

INTRODUCTION

Overview

Service Center

Standard and Mill Products

Page 1 - 27

**High
Performance
Disc**

Size 103 thru 905
Never Needs Lubrication
Proven Disc Design
Koplon* Coated Disc



Page 30 - 46

KS Disc

Size 103 thru 905
More Economical Design
Large Bore Capacity



Page 47 - 49

**High
Performance
Diaphragm**

Size 1.0 - 5.5
Field Replaceable
Stainless Steel Diaphragm



Page 50 - 57

**Custom
Design
Couplings**

Specialty Applications
Moment Simulator



Page 58 - 60

**High Performance
Gear
AC Series**

Size 1 1/4 thru 7.0
Reliability Proven
Greatly Extended Life



Page 62 - 73

The trademarks Kop-Flex®, Fast's®, Powerlign®, MAX-C®, KD®, KD2®, Kop-Grid®, Elastomeric™ and Odyssey™ are registered trademarks or trade names of Emerson Power Transmission Manufacturing, L. P. and/or Kop-Flex Inc.

*Koplon is a trademark and/or a trade name of E. I. du Pont de Nemours and Company. The trade names, trademarks and/or registered trademarks of others are used herein for product comparison purposes only, are the property of their respective owners and are not owned or controlled by Emerson Power Transmission Corporation. Emerson Power Transmission does not represent or warrant the accuracy of this document.

The Emerson logo is a trademark and a service mark of Emerson Electric Co.

© Emerson Power Transmission Manufacturing, L. P. or affiliates 2004. All Rights Reserved.

KOP-FLEX® Couplings

MAX-C Resilient/ Hybrid

High Torque
Maintenance Free
Absorb Shock
Bore Range 3 1/8" to 14 7/8"



Page 74 - 77

Powerlign Torquemeter

Performance Monitoring System
Reduce downtime
Accuracy to within 1%



Page 78 - 85

Hydraulic Installation & Removal Tooling & Auxiliary Items



Page 86

Coupling Grease

KHP High Performance Grease
KSG Standard
Operating Range - 40° to +190°



Page 87

KD Disc

Size 103-905
Bore Range 1 1/2" to 13 1/2"
High Torque Capacity
Excellent Balance Characteristics



Page 88 - 108

KOP-FLEX®

We Provide Coupling Solutions

Smart innovation. This is the key differentiator that sets Kop-Flex high performance couplings apart. From the invention of Fast's – the world's first gear coupling – to modern-day, high performance couplings, Kop-Flex's rich industry background stands behind a reputation for creating products that solve customer problems.

Building couplings based on customer input is the core of Kop-Flex's solution-oriented design philosophy. By combining customer feedback with market trends, Kop-Flex engineers have created an entire line of coupling products that deliver high levels of performance for reliable, continuous operation.

At Kop-Flex, new product development is a core competency providing you with a significant advantage over coupling manufacturers with limited offerings. Kop-Flex offers a winning formula of new coupling products, services, support and global resources to deliver end-to-end solutions.

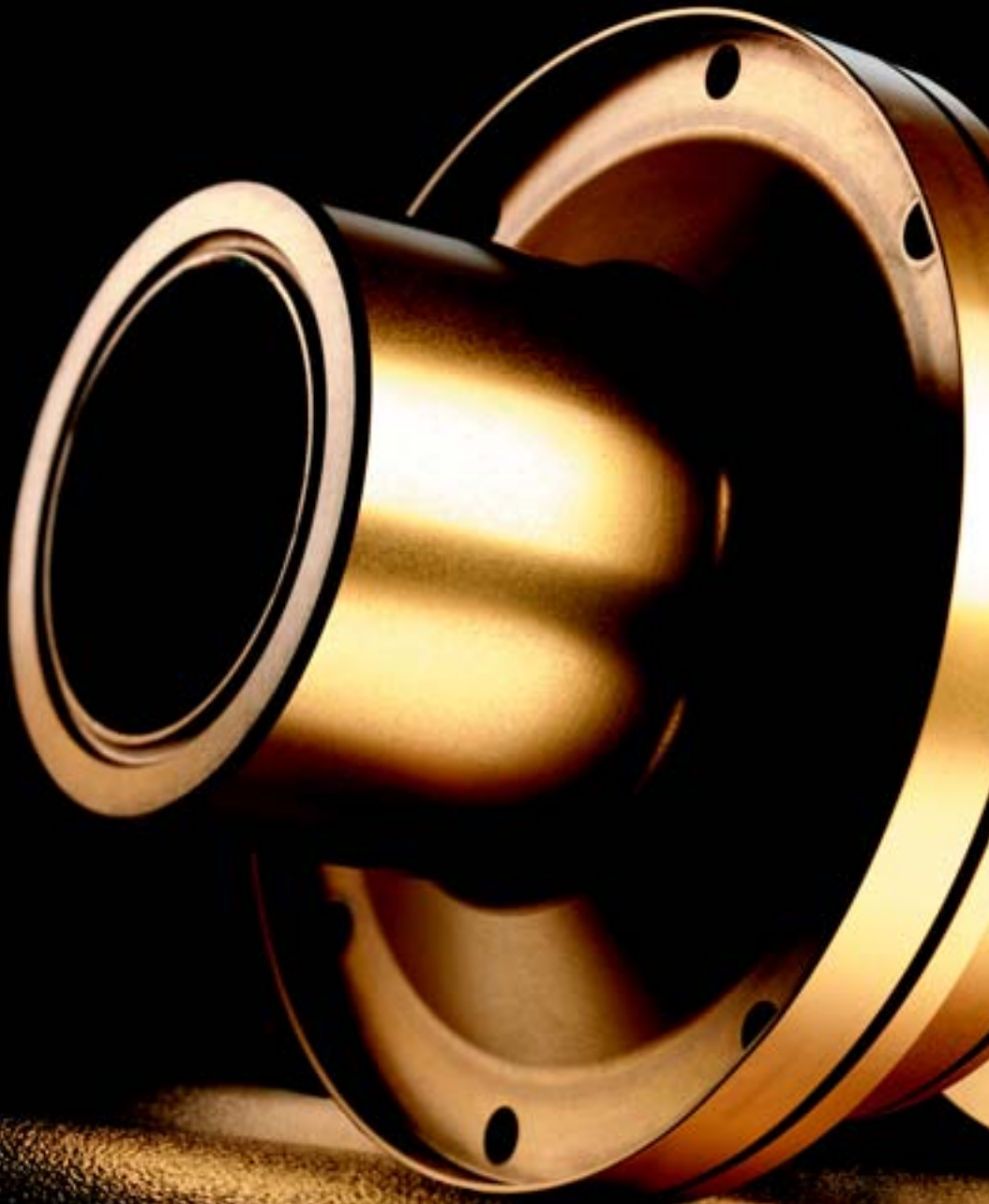

A Single Source for All Your Application Needs

Kop-Flex offers the broadest range of coupling products available on the market today – from high performance, high-speed disc, diaphragm and gear couplings to off-the-shelf, standard couplings as well as engineered gear, grid, jaw, elastomer, disc, universal joints and customized couplings to meet your unique application challenges. Kop-Flex also offers the Powerlign Performance Torque Monitoring System. With a wide variety of coupling products, Kop-Flex provides a single source for all your demanding application requirements.

Kop-Flex high performance coupling products fulfill customers' needs for demanding turbomachinery applications such as steam or gas turbines; compressor, generator, motor driven drives; boiler feed pumps and special pumps for industries ranging from petrochemical, refinery, power plants, LNG, gas pipeline, test stands and more.

Kop-Flex also offers coupling products for rolling mills and casters in steel mills, paper machines (both wet and dry ends), mines, liquid handling pumps and motors (for processing or liquid handling applications) and more.

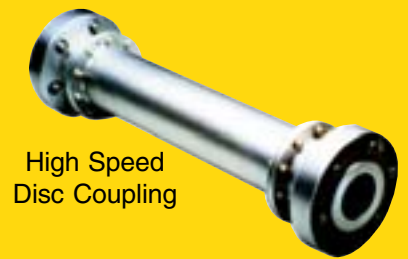

High Speed Disc Coupling



Diaphragm Coupling



High Performance Gear Coupling

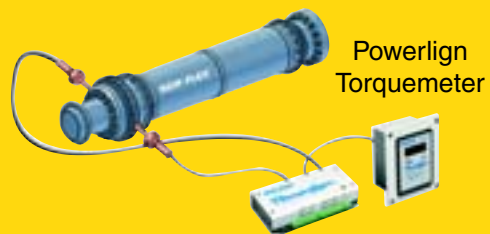

Powerlign Torquemeter

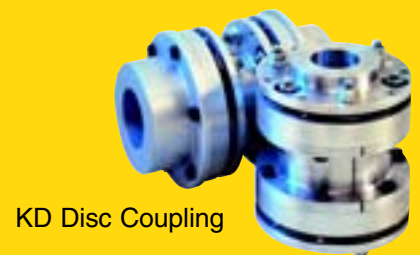

KD Disc Coupling

Client Focused, Solution Oriented

With more customized application designs than any other coupling provider, Kop-Flex products are engineered to meet API (American Petroleum Institute) 671 (ISO 10441) or API 610 (ISO 13409) or your own specifications.

In addition to delivering the most extensive line of couplings in the industry, Kop-Flex emphasizes solution-based engineering results in new, cutting edge coupling designs to help solve your most demanding application issues.

Lean Enterprise

Kop-Flex practices lean manufacturing and lean enterprise principles as part of a corporate focus on quality. Kop-Flex management champions the “lean” concept, which is reinforced company-wide through education and employee training. This philosophy focuses on identifying and reducing waste as part of the design and manufacturing process to improve lead time and delivery, increase productivity, enhance product quality and deliver long-term cost advantages to customers.



Innovation

Kop-Flex has pioneered more products to meet customers' expectations than any other industry player. For example, when customers demanded a high performance methodology for monitoring torque, Kop-Flex created the Powerlign Performance Torque Monitoring System – the most reliable, accurate system available in today's marketplace. Kop-Flex provides a systems solution by packaging torque monitoring (sensors and electronics) with coupling products from a single source.

In addition, Kop-Flex created a mechanism to reduce design cycle time. Beginning with customers' requirements for coupling selection - Kop-Flex created a unique design tool called iCAP™, on the Internet, that selects and designs per API/ISO or customer specifications. The tool also generates mass elastic data and creates CAD drawings, including a bill of materials. This helps customers confirm that a proposed solution will meet stated requirements and rotor dynamics. The resulting design is viewable online and can be downloaded in various formats. Visit www.kopflex.com/productselection or contact a Kop-Flex representative in your area for more information about this valuable tool.

In addition to recently granted patents and other designs in progress, these innovative new products help Kop-Flex meet customers' challenges today and tomorrow.

Regional Competency Centers and World-Class Service

Kop-Flex has facilities in the U.S.A. (Baltimore), Canada (Toronto) and Europe (Slovakia) and a service center located in Houston (U.S.A.) A new, state-of-art, European manufacturing and service center, based in Nove Mesto, Slovakia serves Europe, the Middle East and Asia.

The new center in Slovakia is designed to satisfy European, Middle East and Asian requirements for Kop-Flex couplings for improved service and timely product delivery.

With global delivery operations, Kop-Flex can provide made-to-order couplings within hours or days and can satisfy urgent requirements if a customer's plant or application is down unexpectedly.

Kop-Flex also practices an extensive inspection process and can repair or refurbish any coupling – including designs produced by other manufacturers. Customer risk is further reduced with the full Kop-Flex warranty.

TORONTO ●

BALTIMORE ●

HOUSTON ●

 SLOVAKIA



Service Center in Nove Mesto, Slovakia

A History Of Performance

Gustav Fast invented the first gear coupling in 1918. In 1920, a company called Bartlett Hayward* sold the first coupling and in 1926, Koppers* acquired Bartlett Hayward* and the couplings became known as “Koppers* couplings”. (This explains why many in the industry still refer to Kop-Flex couplings as “Koppers.”*)

In 1986 Koppers* sold the business and it became known as Kop-Flex. In 1996 Emerson Power Transmission acquired Kop-Flex and began marketing the company with two leading coupling brand names – Browning® and Morse®. Between the three coupling brand names – Kop-Flex, Browning and Morse – Emerson Power Transmission represents the most comprehensive line of couplings in the industry.

Emerson Power Transmission is a production and marketing subsidiary of Emerson, a global leader in uniting technology and engineering to deliver innovative solutions in industrial automation; process control; heating, ventilating and air conditioning; electronics and telecommunications and appliances and tools.

Emerson Power Transmission is also the leading power transmission manufacturer with brands including McGill®, Sealmaster®, Rollway® and US Gearmotors™ with products that include bearings, gearing, gearboxes, sheaves, pulleys, chains and more.

The corporation’s extensive manufacturing and distribution network supports over 3,000 industrial distributor locations worldwide and also sells directly to OEMs and end users.

For more information about Kop-Flex couplings, visit www.kopflex.com for technical papers, application information, FAQs, sales literature and instruction sheets, product updates and more.

For assistance contact Kop-Flex today at 1-410-768-2000 or e-mail coupling-engineering@emerson-ept.com.



*Koppers is a trademark and/or a trade name of Koppers Co. Inc.

*Bartlett Hayward is a trademark and/or a trade name of Bartlett Hayward Company.

These trade names, trademarks and/or registered trademarks of others are used herein for product comparison purposes only, are the property of their respective owners and are not owned or controlled by Emerson Power Transmission Corporation. Emerson Power Transmission does not represent or warrant the accuracy of this document.



Thought Leadership

Kop-Flex leads the coupling market in engineering expertise. With the largest engineering staff in the industry, Kop-Flex custom designs solutions using the latest CAD, finite element, vibration analysis and other tools. Kop-Flex also holds more active patents than any other coupling manufacturer.

In the spirit of stewardship and progressive coupling design, Kop-Flex engineers share leading engineering and design practices through frequent white paper authoring and presentation opportunities in leading international trade journals and conferences like Turbomachinery Symposium, ASME, Turbomachinery International, Compressor Technology, World Pumps and more. The latest papers and information can be viewed at www.kop-flex.com/TechnicalPapers.

High Performance Flexible Disc Couplings

- Never needs lubrication
- Koplon* coated, flexible disc elements for maximum life
- Reduced windage configurations
- Easy-to-install with factory-assembled half-couplings and center sections
- Inherent, "fail-safe" designs
- Proven disc design

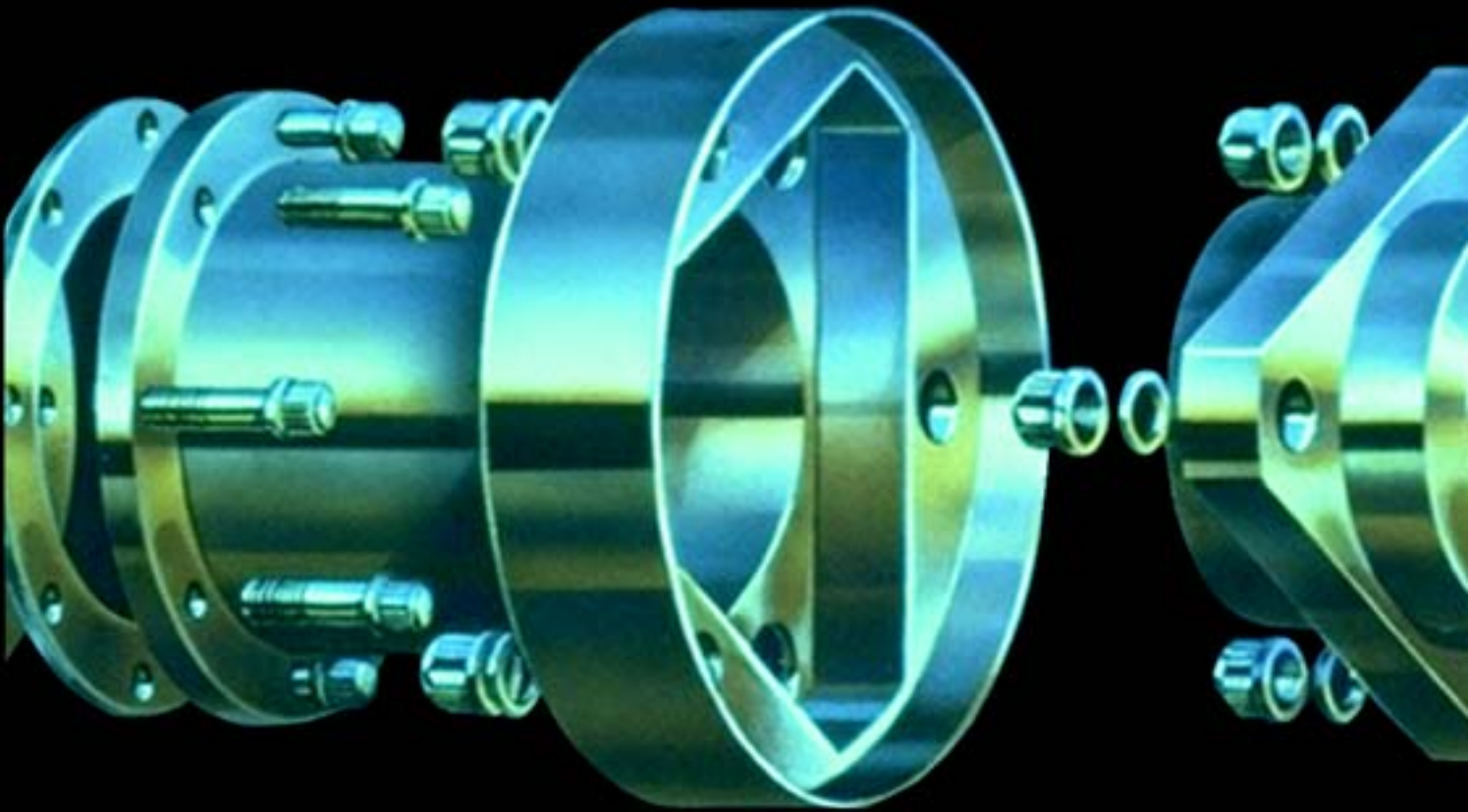

Theory Of Operation

A flexible coupling must perform two tasks: (1) transmit torque from driving to driven shaft and (2) accommodate shaft misalignments. Kop-Flex high performance couplings are designed specifically to accomplish these tasks for very demanding, drive system applications such as boiler feed pumps, centrifugal and axial compressors, generator sets, test stands, marine propulsion drives and gas and steam turbines.

*Koplon is a trademark and/or a trade name of E. I. du Pont de Nemours and Company. This trade name, trademark and/or registered trademark is used herein for product comparison purposes only, is the property of its respective owner and is not owned or controlled by Emerson Power Transmission Corporation. Emerson Power Transmission does not represent or warrant the accuracy of this document.

Coupling Design Is The Key

The innovative Kop-Flex high performance disc coupling design provides a highly reliable, rotating machinery connection. Factory assembly of the disc packs ensures optimum quality and performance and keeps installation time to a minimum.

Further, Kop-Flex high performance disc couplings are designed with API 671 in mind for fit, tolerance, materials, inspection and balance. These couplings are designed and manufactured to meet API 671 as a standard.

Hubs, sleeves and spacers are heat-treated alloy steel while the flexible elements are a series of corrosion resistant, high strength, stainless steel discs coated with Koplon*. Accessories are high quality steel fasteners.

As a result of factory assembly, interference fit pilots and tight fitting bolts, the couplings retain their balance integrity even after repeated reassembly.



Design Options

The Kop-Flex coupling is available in four standard designs to accommodate operating conditions. The full featured RM and its economical alternative, the RZ, allow the lowest overhung moment available. The marine styles, the interlocking flange MS and the standard MP allow for installing and removing factory-assembled center sections without removing the rigid hubs. These hubs also accommodate larger bore capacities.

The "fail-safe" interlocking design available on the RM and MS styles (wherein the sleeve and hub or adapter flanges mate for a redundant connection) so there will be no instantaneous separation of the driving and driven shafts in the unlikely event of a disc pack failure.

Special designs, such as non-standard adapters to mate with integral flanges, are readily available. In addition, special materials such as titanium spacers or Inconel* disc packs are also available. Please consult Kop-Flex.

* Inconel is a trademark and/or a trade name of Huntington Alloys Corporation.

* Koplon is a trademark and/or a trade name of E. I. du Pont de Nemours and Company.

These trade names, trademarks and/or registered trademarks of others are used herein for product comparison purposes only, are the property of their respective owners and are not owned or controlled by Emerson Power Transmission Corporation. Emerson Power Transmission does not represent or warrant the accuracy of this document.

The Flexible Disc Pack

The Flexible Disc Pack is the heart of the Kop-Flex High Performance coupling and transmits torque while accommodating axial, offset and angular misalignment.

The Flexible Disc Pack is a series of precision manufactured discs assembled with washers and bushings into a unitized pack. The disc material is special, high strength, 301 stainless steel and each disc is Koplon* coated to help prevent fretting corrosion. Alternate disc materials, such as Inconel, are available; consult Kop-Flex.

The discs have a “waisted” or “scalloped” link design. This results in increased flexibility and subsequent lower reaction forces on the connected equipment bearings. Further, stress distribution is uniform, which allows for increased misalignment capability and lower fatigue stresses on the discs. The scalloping also reduces weight and inertia.

The discs are designed for infinite life with a factor of safety. Under loading, the disc pack is exposed to constant stresses due to torque, centrifugal force, axial misalignment and pretension, and to alternating stresses due to angular and offset misalignment.

The combined effect of these stresses is plotted on a modified Goodman diagram, which gives the disc material endurance limit boundaries. Generally, at normal operating conditions, and at maximum angular misalignment and axial displacement ratings, the discs operate with a nominal safety factor of 2.

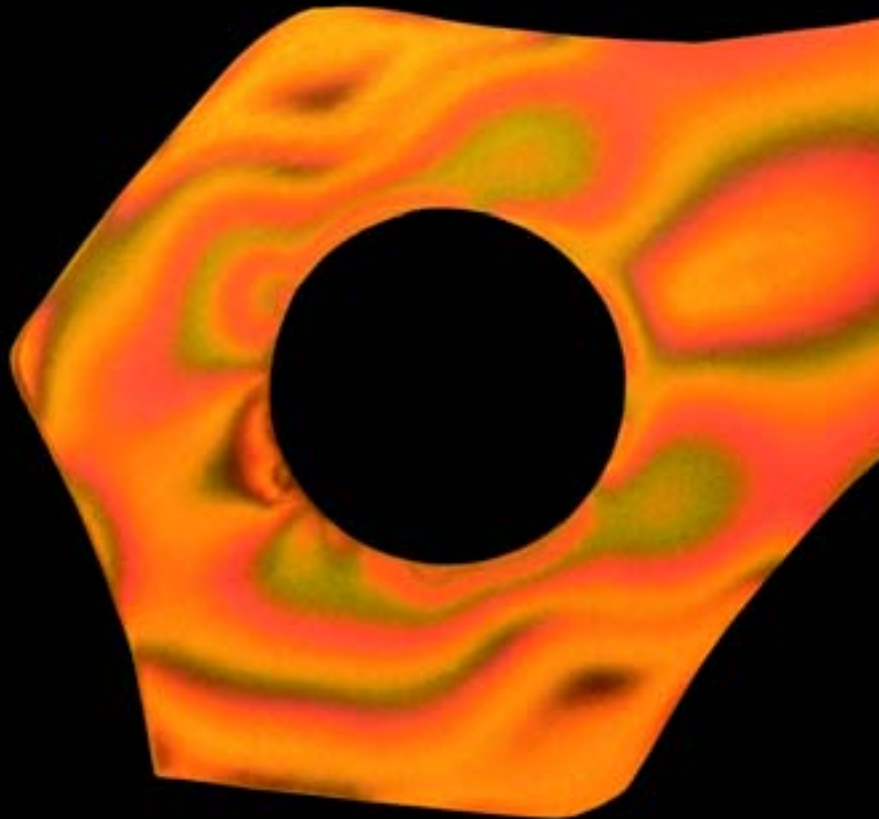

*Koplon is a Teflon based (PTFE) material of proprietary formulation.

*Koplon and Teflon are trademarks and/or trade names of E. I. du Pont de Nemours and Company.

These trade names, trademarks and/or registered trademarks of others are used herein for product comparison purposes only, are the property of their respective owners and are not owned or controlled by Emerson Power Transmission Corporation. Emerson Power Transmission does not represent or warrant the accuracy of this document.

Kop-Flex Disc Advantages

- More flexibility
- Lower reaction forces
- 301 stainless steel
- Koplon* coating
- Uniform stress distribution
- Reduced weight and inertia
- Unitized assembly

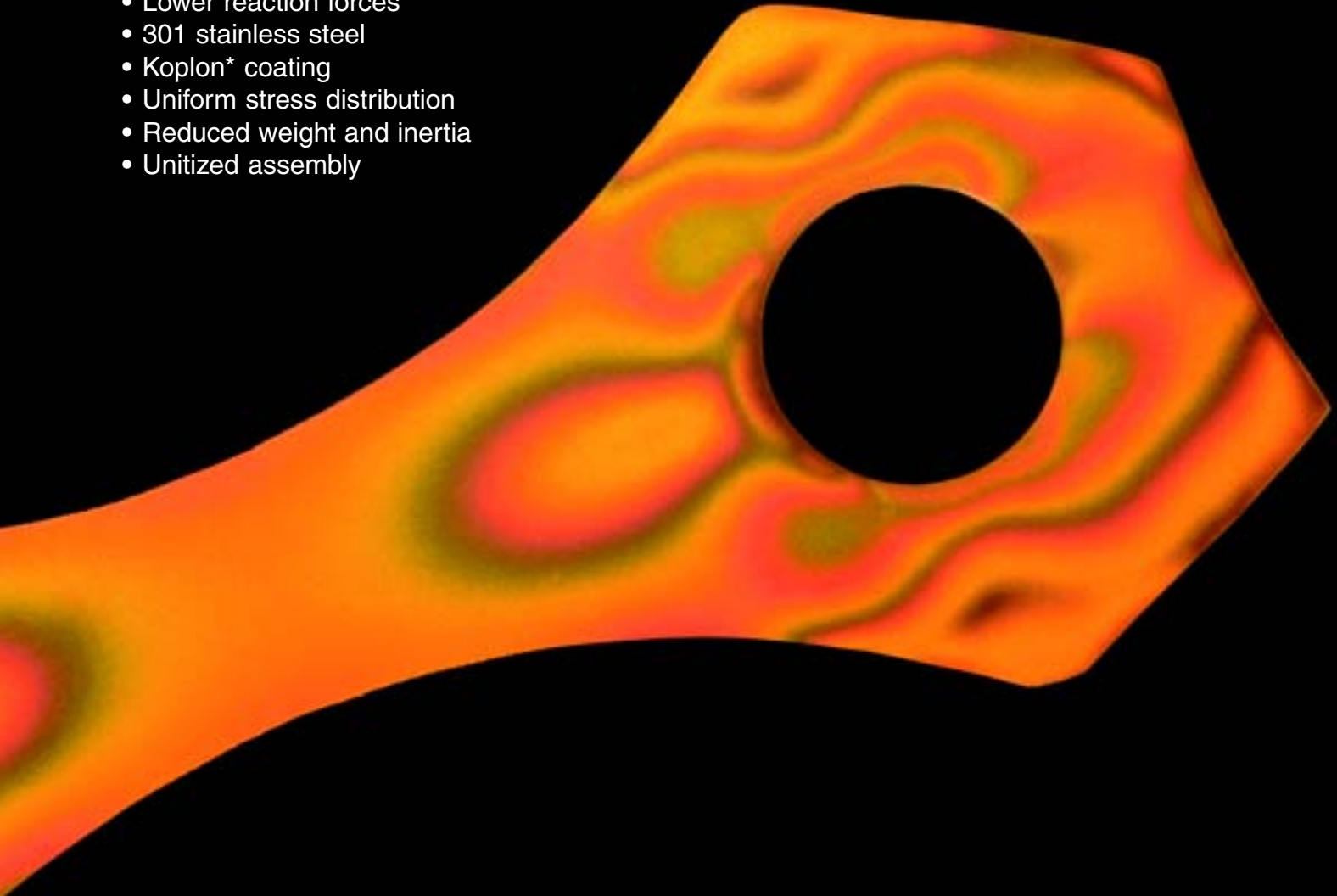

**Kop-Flex High Performance Disc Coupling
Modified Goodman Diagram
Typical Application**

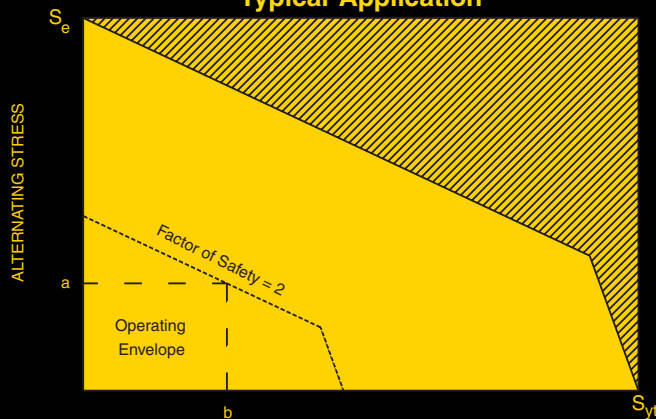

a = 100% angular misalignment
b = Normal operating HP and speed + 100% axial misalignment

*Koplon is a Teflon based (PTFE) material of proprietary formulation.
*Koplon and Teflon are trademarks and/or trade names of E. I. du Pont de Nemours and Company.
These trade names, trademarks and/or registered trademarks of others are used herein for product comparison purposes only, are the property of their respective owners and are not owned or controlled by Emerson Power Transmission Corporation. Emerson Power Transmission does not represent or warrant the accuracy of this document.

Flexible Diaphragm Couplings -- The Next Generation in High Performance Coupling Design



Size #8.5 MSM ("J" Type Frame 7 Load Coupling—operates in excess of 250,000 HP (186 MW) at 3600 rpm. (Shown next to size #1.5 RMM.)

Customized diaphragms for special applications using Finite Element Analysis (FEA).

- No welds
- No splines
- Patented, replaceable flex elements

Basic Theory of Operation

Our diaphragm couplings transmit torque from the driving shaft via a rigid hub then through a flexible diaphragm to a spacer. While transmitting torque to the spacer, the diaphragm deforms to accommodate misalignment. The spacer, in turn, drives matching components attached to the driven equipment.

Kop-Flex Revolutionized Diaphragm Design

Kop-Flex has manufactured extremely reliable, maintenance-free diaphragm couplings since the mid-1970's, with well over ten million hours of operation. Our early experience making diaphragm couplings led us to reexamine prevailing diaphragm design. In 1989, we developed and patented a unique refinement technique eliminating the need for welds and allowed for field replaceable flex elements. In addition, we began to take full advantage of our FEA and computer aided, manufacturing techniques. The result? Kop-Flex High Performance Diaphragm Couplings combine the positives of competing diaphragm couplings with additional design features. It is also easier to replace a competing diaphragm coupling with a superior Kop-Flex coupling.

How Kop-Flex Improves the Best Features of Diaphragm Couplings

Field replaceable, stockable diaphragms

Advantages

- Fast, easy repair
- More reliable

The Kop-Flex diaphragm is bolted (not welded) to the spacer. You can remove these diaphragms without moving the equipment or removing the rigid hub. This reduces downtime and expense. It is much easier to stock or reorder a replaceable Kop-Flex diaphragm than a big welded assembly. And since field failures sometimes occur in welds, our newer no-weld design is more reliable.

Specially contoured one-piece diaphragm

Advantages

- Simple, less hardware
- Cost competitive
- Easy to customize
- Quick delivery

Like any diaphragm coupling, our ability to transmit torque and handle misalignment depends chiefly on the thickness distribution (or profile) of the diaphragm. Unlike competing designs, we use a single stainless steel diaphragm. This eliminates the need for extra bolts, rivets, splines and filler rings. It also greatly simplifies the task of shaping the perfect diaphragm, since we need only one diaphragm per end. We use a modified profile based on extensive FEA. The thickness of the diaphragm varies so stress is distributed evenly when the diaphragm flexes under the simultaneous effects of torque, speed, axial misalignment and angular misalignment. Also, unlike competitors, Kop-Flex translates CAD and CAM into quick deliveries. These techniques stand behind our ability to customize diaphragms for special applications.

Patented, donut-shaped diaphragm

Advantages

- Handles more misalignment
- Greater range of torsional stiffness

The unique Kop-Flex diaphragm profile follows the modified power function toward the center. Unlike any competing designs, the diaphragm doubles back before it's attached to the spacer. Rather than a flat or wavy disc, the Kop-Flex brand diaphragm is more like a donut shape and is one piece of stainless steel. In effect, this delivers more diaphragm in a given space. This allows the Kop-Flex diaphragm to handle more torque, axial misalignment or angular misalignment than competing designs of comparable size.

Other Features

- Piloted fits
- Diaphragms are 15-5/17-4 PH shot-peened, stainless steel
- Inherently low windage design conforms to API 671

Options

- Electrically insulated
- Shear section type
- Torsionally damped hybrids
- Torque measurement
- "Fail-safe" back-up gears
- Alternate spacer materials
- Customized profiles for special applications

High Performance Gear Couplings AC Series For High Speed Requirements

Application

The Series AC coupling design is intended for high performance applications where either high speed or high torque operating conditions prevail. The actual capacity of the coupling is a function of the combination of load, speed and alignment accuracy. The material used is low alloy steel, heat-treated to attain optimum properties of strength, hardness and toughness. The properties of the material in the heat-treated state, therefore, allow for much higher torque loads than for other coupling classifications, which use carbon steel.

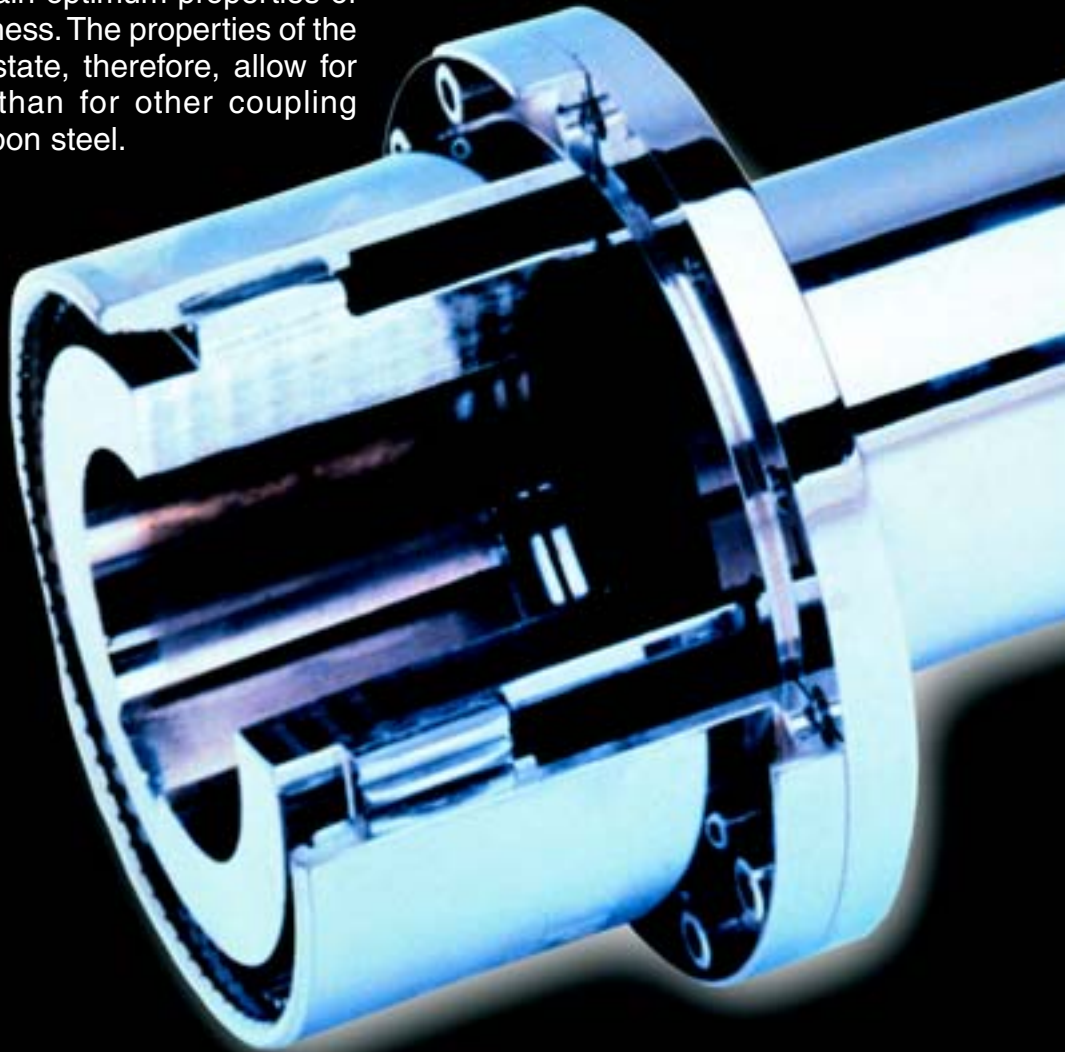

Description

The Series AC coupling is held to the close manufacturing tolerances consistent with industrial practice. These highly accurate tolerances allow the coupling to be more accurately, dynamically balanced and also allow inherently higher torque capacities than if the manufacturing tolerances were equivalent to the standard type coupling. The mating flanges of the coupling and spacers used are positioned to each other by accurately turned rabbets to maintain repetitive accurate dynamic balance should the coupling ever, for any reason be disassembled and reassembled. The root of the sleeve teeth and this spherical major diameter of ball of the hub teeth are closely fitted to maintain accurate concentricity. This is important in maintaining dynamic balance.



Installation

Class AC couplings are commonly used in turbine-driven equipment where thermal growth and distortion are substantial. Under these operating conditions, thermal growth must be identified and compensated for accordingly.

After installation and cold alignment, the equipment should be run and brought up to operating temperature. The alignment should then be checked in the hot condition using the hub sections that project beyond the sleeve end ring as reference points. This operation can be accomplished without disassembling the coupling.

High Performance gear couplings require lubrication, either continuous or batch. Continuous lubricated couplings require a clean, filtered oil supply and a coupling guard complete with oil supply and drain lines. Batch lubricated couplings can be used for low or moderate speeds where the coupling can be packed with KHP grease at installation. All lubricated couplings require maintenance attention to prevent contamination and sludge accumulation, which can reduce coupling life or degrade the coupled machine performance.

The Series AC coupling is dynamically balanced and must be assembled with parts in the same relative position as when balanced by the factory. Match marks are scribed on all parts to permit proper assembly and reassembly. Bolts and nuts are individually weight balanced, which allows the interchanging of any bolt with any nut.

KOP-FLEX®

Kop-Flex – The Widest Range of Coupling Solutions

Kop-Flex offers the broadest range of coupling products on the market today. From high performance, high-speed disc, diaphragm and gear couplings to off-the-shelf standard couplings, Kop-Flex also provides engineered gear, grid, jaw, elastomer, disc, universal joints and customized couplings to meet your unique application challenges.

Kop-Flex high performance couplings fulfill customers' needs for demanding turbomachinery applications such as steam or gas turbines; compressor, generator, motor driven drives; boiler feed pumps and special pumps for industries ranging from petrochemical, refinery, power plants, LNG, gas pipeline, test stands and more. Couplings meet API 671, ISO 10441, API 610, ISO 13709 and other industry standards.

Kop-Flex also offers coupling products for rolling mills and casters in steel mills, paper machines (both wet and dry ends), mines, liquid handling pumps and motors (for processing or liquid handling applications) and more.

A History of Innovation & Design Excellence

Powerlign Performance Torque Monitoring System for Coupling Applications

From the invention of Fast's – the world's first gear coupling – to today's high performance couplings, Kop-Flex has a rich industry background and a reputation for solving customer problems.

Faced with rising fuel costs and increasing environmental concerns such as No_x (*nitrous oxide*) emissions standards, torquemeters are increasingly being used to measure power, speed and torque on critical rotating machine equipment.

Torque differentials can indicate performance problems such as blade fouling and over-torque can lead to coupling shaft or equipment failure. When performance declines, more fuel is burned and No_x emissions increase. Torquemeters provide a cost-effective method for diagnosing these problems early on so you can make the necessary adjustments to your system for a proactive maintenance plan.

From Simple Diagnostics to True Control

As the only company in the world that has developed an integrated coupling-torquemeter solution, Kop-Flex introduces the newly designed, digital Powerlign Performance Torque Monitoring System.

As the most reliable, accurate torquemeter available in today's marketplace, the digital Powerlign replaces the proven, analog Powerlign system that has served the market for the last ten years. Powerlign features a patented, unique architecture that allows for more advanced system control with full integration support for distributed control systems (*DCS*) such as Emerson Process Management's DeltaV™ system or PCs and laptops for analyzing system data.

Powerlign acts as an important part of a closed loop system by establishing certain thresholds that can be configured to trigger an alert or alarm. Powerlign can also be used as a control system to shut down equipment or direct the in flow of gas or fuel to maintain load and efficiency.

Key Benefits

- All new, **digital** phase-shift, non-strain gauge system
- As a **single source supplier** of couplings and torque meters, Kop-Flex eliminates coordination and design integrity issues that occur with multiple suppliers
- Simplicity of design reduces margin for error—with accuracy within $\pm 1\%$
- **Safety and reliability** – unlike other torque measuring devices, no electronics or electrical power is present in the coupling or in the coupling environment
- **Seamless integration** – connect the Powerlign conditioning unit directly to a DCS like the DeltaV system or others running public or private MODBUS protocol, reducing the cost of setting another box or training your operator to use a new system
- **Retrofit** - For most applications, a new instrumented spacer can be inserted without disturbing the existing flex half couplings

No Other Torquemeter System Offers Consistent Accuracy

The accuracy rating is determined as a root sum of the squares series of all the individual errors possible, both electrical and mechanical.

The mechanical inaccuracies include allowances for the inevitable movements of the coupling in relation to the guard-mounted sensor, during hot and cold cycles of equipment operation. These are the radial gap and axial movement errors. Other mechanical errors are possible from the various calibrations and set-ups.

Electrical items include sensor variation and conditioning unit variation. Note that because these errors are included in the overall budget, sensors and boxes from the factory or stock can be swapped out in the field without degradation of accuracy. Powerlign and Powerwheel are accurate to within one percent.

- Specially configured MODBUS communication protocol available to fit with your **existing DCS**
- **Significant cost savings** – considering that a 40MW gas turbine consumes \$8,000,000/year in 2003 fuel costs, a one percent increase in efficiency equates to \$80,000 in annual savings
- Aids in **environmental compliance** efforts by helping to reduce No_x emissions through improved fuel monitoring
- **Completely interchangeable** components and no need for recalibration
- **Highly flexible** – fewer components, easier to install and no need to disturb or modify any vents, drains, filters, etc.
- ATEX, CE and CSA certification for explosion proof sensors (Div I), intrinsically safe conditioning unit and display unit (Div II) operation
- RS-232 digital, RS-485 digital and 4-20mA analog output
- Decreased lead times
- Reduced wiring cost
- Uses existing coupling guard
- User configurable imperial inch or metric (SI) units
- Built-in, automatic temperature compensation; sensors operate at temperatures as high as 350°F (177°C) to accommodate the most demanding environments



Kop-Flex - The Worldwide Leader in Coupling Design, Manufacturing and Service

For over 80 years Kop-Flex has provided the industry's most extensive service and repair facilities in North America. Primary facilities are located in Baltimore, Toronto and our newest operation in Nove Mesto, Slovakia. Licensed repair facilities are located in Indiana, Texas and California. Each location houses state-of-the-art equipment to provide a complete and thorough analysis of your repair needs.

The latest measurement equipment (CMM), inspection tools, non-destructive testing (MPI, dye-penetrant, X-ray), balancing equipment, welding machines, and modern CNC machining centers can address needed repairs, with access to one of the largest engineering staffs in the industry. A dedicated service center team comprised of experienced engineers, customer service representatives, repair coordinators and functional area experts is available to handle your repair needs.



Kop-Flex state-of-the-art manufacturing and service center in Baltimore, MD

Question: How do you end headaches and save money with preventive maintenance?

Answer: Team-up with Kop-Flex.

You want your couplings to function for as long as possible. Kop-Flex is committed to producing a durable product and will help you stay up and running with a predictive, proactive and preventive maintenance program. Let the leader in couplings design a program to suit your needs. The fact is that you can repair a coupling, gear spindle or universal joint for about half the cost of buying new. It takes special design, fabrication, quality control and operations know-how. Don't trust your highly engineered product to just any repair shop. Demand Kop-Flex.

The Industry's Most Experienced Engineers and Technicians are Available to You

Representatives can be on-site at your operation for:

- Field failure analysis
- Supervision of coupling installation/removal
- Field training maintenance, installation and troubleshooting

Call 1-410-768-2000 for details on rates and to schedule assistance.

Center Programs

Coupling Program

Repair Worn Equipment and Save

30 to 90 Percent of the Cost of Buying New
It takes knowledge, experience and the proper facilities to repair a highly engineered product. Kop-Flex offers:

- Engineers and field service specialists that work with your maintenance staff to understand the unique parameters of your application
- Inspection reports detailing type of wear and/or damage and recommended action
- Exact price quotations
- Repair services for other manufacturers' couplings and spindles, including recommendations to improve life through design changes and/or material upgrades
- Highly skilled and experienced technicians

Typical savings range from 30 to 90 percent of the price of a new coupling. Save money and time. Kop-Flex can often inspect, report, quote, repair and ship back to you within six weeks. Kop-Flex leads the industry in our ability to respond to your repair needs.



High performance coupling for refurbishment

Let Our Experts Provide You With an Analysis and a Recommendation

Unfortunately, no mechanical product can last forever and couplings are no exception. While Kop-Flex products are designed and built to last, many applications are so severe that rapid wear and/or coupling damage may occur.

Kop-Flex has the largest and most experienced engineering staff in the industry, with an arsenal of modern analysis tools at our disposal including FEA, an in-house R&D center and a staff focused solely on couplings. Our technical experts go beyond mere failure analysis by providing recommendations on how to help prevent future coupling problems.

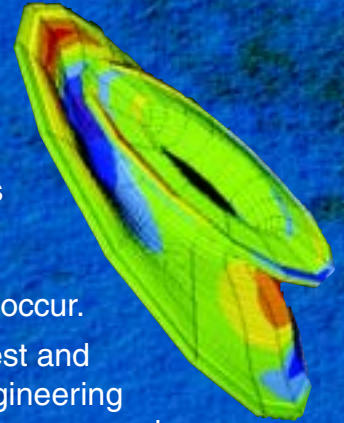

Case Study

At one, major Midwest steel plant, our management program reduced the spindle maintenance cost per ton of rolled steel to less than half of what it once was. When you consider the tangible, direct-cost savings, reduced downtime and extended component life, you can see how coming to Kop-Flex can reward you with big savings.

Kop-Flex Service Centers Offer:

- Repair and refurbishment
- Expert failure analysis
- Cost savings through consultation
- Field technical support

Visit us at
www.kop-flex.com

Gear Spindle and Universal Joint Coupling Program

Gear spindles, universal joints and couplings are at the heart of steel, paper, cement and many other types of mills. A sound design and solid service support from a world-class manufacturer provides the performance you need.

Inspection Process

Depending on the application, a spindle or universal joint should be completely disassembled and inspected annually. Kop-Flex benefits:

- Saves you time and trouble. As one steel mill maintenance manager puts it: "Mills are in the business of rolling steel - not maintaining spindles."
- A comprehensive, expert-prepared, condition report including recommendations for repair or replacement and any relevant price quotations
- If your spindle is in satisfactory condition, we will reassemble it with new hardware (as needed)
- We will serialize and maintain record of repair, inventory, and parts usage for periodic future review and evaluation

"Like New" for Less

Gear teeth, cross and bearing and yokes are replaced, repaired or returned to original specifications. Worn pilot areas are plated or welded and machined to their original dimensions. Roll end bores are returned to their original dimensions. If needed, accessories and hardware are replaced. All this in about half the time it takes to manufacture a new spindle and at a much lower price.



A universal joint, as received from a customer, at our service center for inspection and rebuilding



Universal joint after refurbishment, serialized for tracking



Like New

Repair and Maintenance Program for Steel, Paper, Cement, and Turbomachinery

for Less...

- Like New for Less...convert used to almost new
- Savings from 30 to 90 percent
- Documented inspection process
- Inventory management program
- Maintenance management program



Call 1-410-768-2000 for details.

Universal Joint Coupling and Spindle Program

Custom-Tailored Inventory and Maintenance Management Program Saves Money and Prevents Downtime

Are you currently spending too much money on spare parts inventory?

Is parts storage a hassle?

Kop-Flex will inventory your spindle, coupling and universal joint stock and develop a usage profile.

Kop-Flex will work with your staff to develop a usage profile and will then inventory parts appropriate to maximizing plant performance. Spindles, couplings and universal joints can then be shipped from our facility to you within 12 to 24 hours. You benefit through added convenience and reduced inventory investment.

Kop-Flex not only repairs and refurbishes but offers a special program to enable peak plant efficiency:

- Company representatives will meet with you to understand your needs and your current inventory of gear spindles and heavy duty couplings
- A usage profile is developed
- Safety levels for components are established
- Kop-Flex will inventory components vital to your operations, eliminating the initial capital expenditure and the cost associated with carrying inventory
 - Inventory is managed on an ongoing basis for a nominal fee
 - Regular review of your stock will help you reach your desired inventory levels

Look to Kop-Flex, the industry leader in couplings, to keep your plant running smoothly and efficiently. Call one of our representatives today about designing a custom program for you.

Additional Benefits of a Kop-Flex Repair, Inventory and Maintenance Management Program

- Customized to your needs - Kop-Flex designs a program that accommodates many, functional areas such as operations, maintenance and procurement
- You save three ways - Kop-Flex will bear inventory carrying cost, diminish your taxable assets and reduce capital expenditures on the wrong spare parts
- Kop-Flex will monitor inventory usage and requirements
- Kop-Flex will reduce unscheduled downtime by optimizing a changeout schedule that takes your needs into consideration
- Pricing can be predetermined to avoid surprises and help you manage your budget

To discuss these and the many other benefits of a Kop-Flex program, call us today. You're closer than you think to saving money and preventing unanticipated downtime.

High Performance Coupling Program Gear, Disc and Diaphragm

High Performance Coupling Inspection and Repair Process

Kop-Flex provides the most extensive evaluation, inspection and repair service in the industry:

- Each component is photographed as received for thorough, engineering inspection
- Couplings are disassembled and all components are tagged
- Non-destructive test on torque carrying components is conducted using magnetic particle inspection (MPI), dye penetrant and X-ray, as required
- Kop-Flex engineers analyze the data and prepare an inspection report detailing findings and offer their expert recommendations on how to refurbish, repair or replace based on the amount of wear and damage and provide a quotation for performing the work recommended is submitted back to you within two weeks of receiving your coupling in our facility
- Couplings will be assembled to original specifications, skimmed at assembly, dynamically balanced to API 671 (ISO 10441) or API610 (ISO 13709) – component or assembly – as required by the application and your specifications
- Quick turnaround - our complete inventory of flex elements and nitrided gear components speeds the process

Once we receive your approval and purchase order, we will immediately refurbish or replace parts as required.

With our facilities in Baltimore, Houston, Chicago, Toronto and Nove Mesto, we can provide prompt service to any of your operations worldwide.



LM 2500 gas turbine coupling
before being refurbished

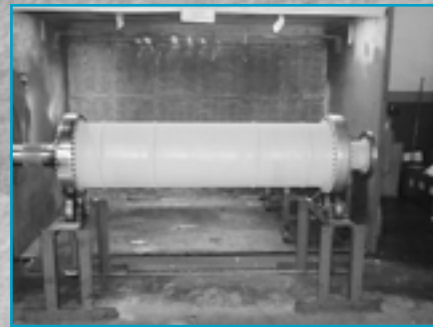

LM 2500 gas turbine coupling
after complete refurbishment

Avoiding Downtime is Critical in High Performance Environments

Kop-Flex can help you recognize significant savings in the following applications:

- Petrochemical plants
- Offshore drilling rigs
- Turbomachinery
- Gas/steam, turbine-driven compressor drive trains
- Synchronous motor drives
- Boiler feed pumps
- Generator drives in fossil fuel and nuclear power plants

Kop-Flex is the industry authority in turbomachinery with strong technical representation on API and ISO committees, as well as active participation in many technical forums. Kop-Flex experts will provide you with objective failure analysis, inspections and reports.

Kop-Flex will repair or refurbish any coupling including those manufactured by our competitors and provide you with a warranty and a proactive plan to reduce costs.

Our process of inspecting and repairing high performance couplings is the most extensive in the industry.

KOP-FLEX®

Standard and Mill Products

More than 80 years of development and manufacturing experience in the coupling industry is behind our name. Kop-Flex, Inc., formerly the Power Transmission Division of Koppers* Company, is one of the world's largest makers of gear, flexible disc and resilient shaft couplings. Our coupling technology, from computer assisted design to space age materials, supplies reliable products of the highest quality. Worldwide, industries rely on Kop-Flex couplings to meet a wide variety of demanding applications from pumps to compressors in petrochemical, process industries and metal rolling mills.



**Odyssey
Couplings**



**KD Disc
Couplings**



Jaw Couplings



**Fast's
Forged
Steel
Couplings**



**Fast's
Cast Steel
Couplings**



**Series H
Crowned
Tooth
Couplings**



**MAX-C
Couplings**



**Kop-Grid
Tapered Grid
Couplings**



**Elastomeric
Couplings**



**Gear Spindle
Couplings**

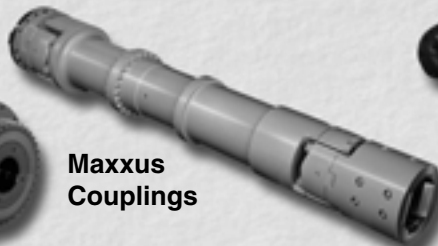

**Maxxus
Couplings**



**Flanged
U-Joint**

*Koppers is a trademark and/or a trade name of Koppers Co. Inc. This trade name, trademark and/or registered trademark is used herein for product comparison purposes only, is the property of its respective owner and is not owned or controlled by Emerson Power Transmission Corporation. Emerson Power Transmission does not represent or warrant the accuracy of this document.



High Performance Couplings

A Single Source for All Your Application Needs

SERVED INDUSTRIES	High Performance Disc	Diaphragm	High Performance Gear	Torquemeter
Refining-Compressor Trains				
Gas Plants	✓	✓	✓	
Catalytic Reforming	✓	✓	✓	
"Cat" Cracking	✓	✓	✓	
Alkylation	✓	✓	✓	
Coking	✓	✓	✓	
Hydrocracking	✓	✓	✓	
Hydrotreating	✓	✓	✓	
Vapor recovery	✓	✓	✓	
Petrochemical - Compressor Trains				
Olefins	✓	✓	✓	✓
Aromatics	✓	✓	✓	
Ammonia	✓	✓	✓	✓
Refining & Petrochemical Critical Pumps	✓	✓	✓	
Natural Gas - Compressor Trains				
Gas Processing	✓	✓	✓	✓
NGL	✓	✓	✓	✓
Gas "Lifting"	✓	✓	✓	✓
Reinjection	✓	✓	✓	✓
Pipeline boosting	✓	✓	✓	✓
LNG	✓	✓	✓	✓
Power Generation				
Gas and Steam Turbine Gen-sets	✓	✓		
Boiler Feed Pumps	✓	✓		
Starter Packages	✓	✓	✓	
Energy Storage				
Motor & Turbine Driven Compressors	✓	✓		
Expander Driven Generators	✓	✓		
Marine Propulsion				
Turbine Driven Water Jets	✓	✓		
Turbine Driven Propellers	✓	✓	✓	
Steam Turbine Gen-sets	✓	✓	✓	
Boiler Feed Pumps	✓	✓	✓	✓

KOP-FLEX 24/7 Global Solution

All worldwide support centers work around the clock to provide customer and team service. Call 1-410-768-2000, e-mail us at coupling-engineering@emerson-ept.com or log onto www.kop-flex.com.

Proven Performance for Today's Demanding Applications

Industries served:

- Petrochemical
- Power generation
- Refinery
- Chemical processing
- High speed marine

- 1 MP Flexible Disc
- 2 MS Flexible Disc
- 3 KS Flexible Disc
- 4 RM Flexible Disc
- 5 RZ Flexible Disc
- 6 MS Diaphragm
- 7 HP Gear ACCS
- 8 Max-C Hybrid
- 9 Gear
- 10 Powerlign
- 11 KD Disc 1, 2, 20, 21
- 12 KD Disc 33
- 13 KD Disc

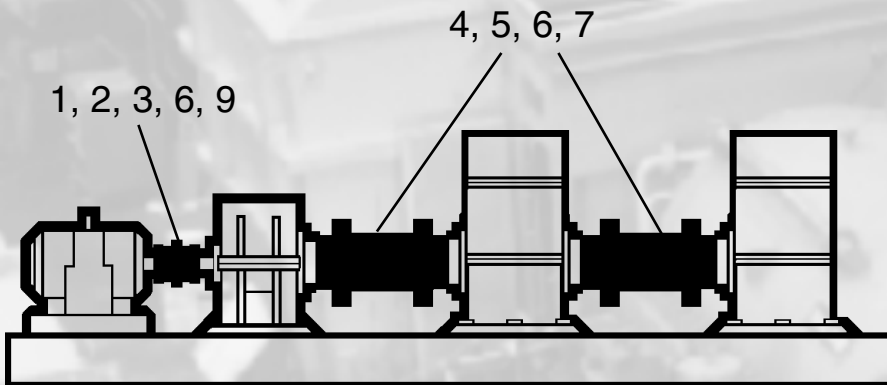

Induction Motor/Gearbox/Centrifugal Compressor/
Centrifugal Compressor

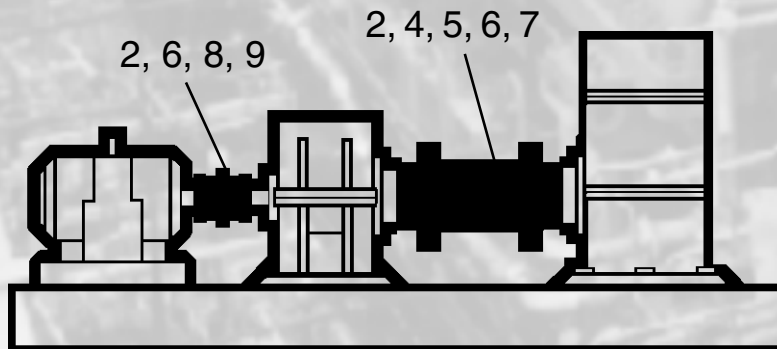

Synchronous Motor/Gearbox/Centrifugal Compressor

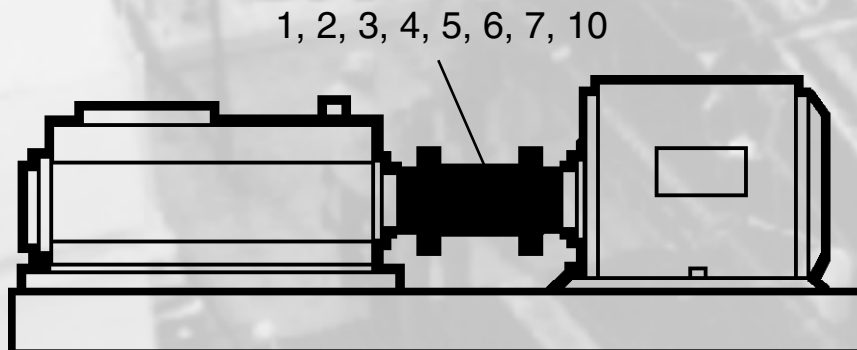

Steam Turbine/Boiler Feeder Pump

KOP-FLEX® High Performance Couplings

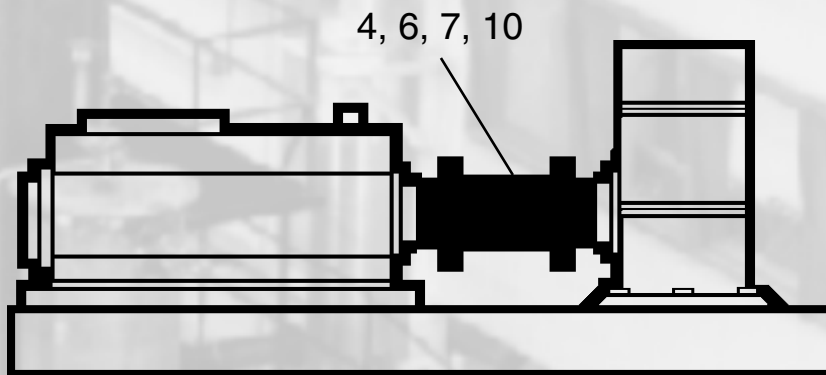

Gas Turbine/Pipeline Centrifugal Compressor

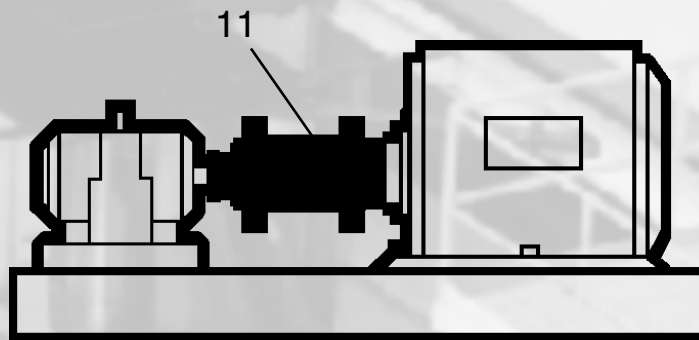

Induction Motor/Process Pump

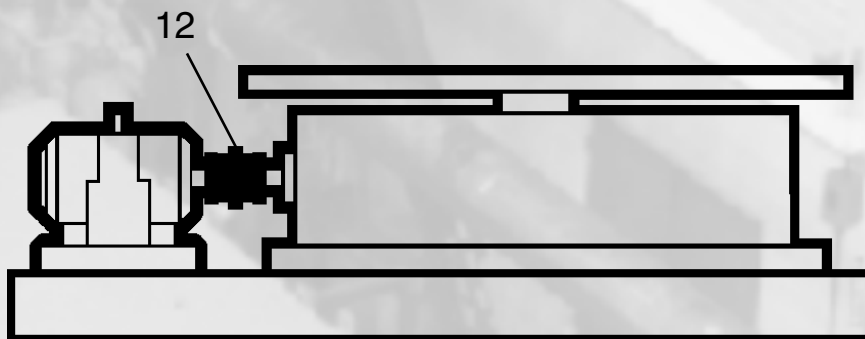

Induction Motor/Cooling Tower

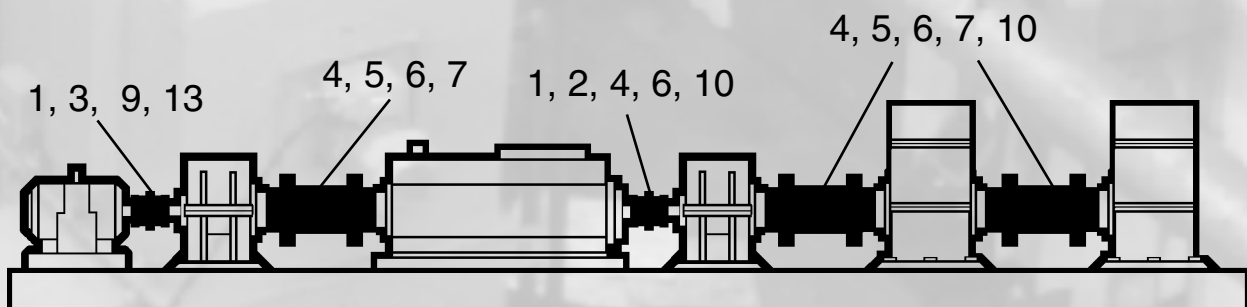

Starter Motor/Gear Box/Gas Turbine/Gearbox/
Centrifugal Compressor/Centrifugal Compressor

High Performance Flexible Disc Couplings

The Kop-Flex Advantages:

- Never needs lubrication
- Koplon* coated flexible disc elements for maximum life
- Reduced windage configurations
- Easy to install with factory assembled half-couplings and center sections
- Inherent "fail-safe" designs
- Proven disc design

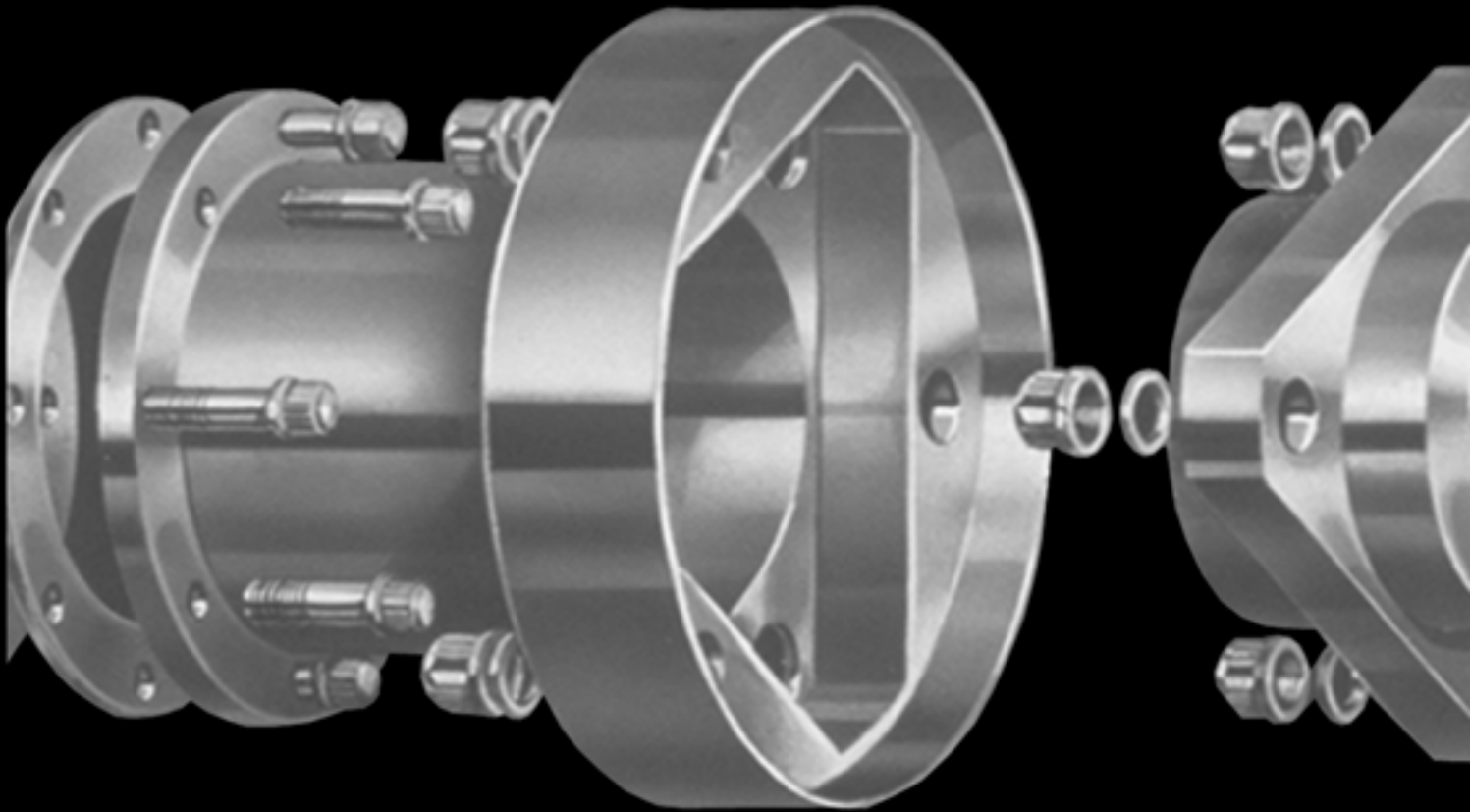

Theory Of Operation

A flexible coupling must perform two tasks: (1) transmit torque from driving to driven shaft and (2) accommodate shaft misalignments. Kop-Flex high performance couplings are designed specifically to accomplish these tasks for very demanding, drive system applications such as boiler feed pumps, centrifugal and axial compressors, generator sets, test stands, marine propulsion drives and gas and steam turbines.

*Koplon is a trademark and/or a trade name of E. I. du Pont de Nemours and Company. This trade name, trademark and/or registered trademark is used herein for product comparison purposes only, is the property of its respective owner and is not owned or controlled by Emerson Power Transmission Corporation. Emerson Power Transmission does not represent or warrant the accuracy of this document.

Coupling Design Is The Key

The innovative Kop-Flex high performance disc coupling design provides a highly reliable, rotating machinery connection. Factory assembly of the disc packs ensures optimum quality and performance and keeps installation time to a minimum.

Further, Kop-Flex high performance disc couplings are designed with API 671 in mind for fit, tolerance, materials, inspection and balance. These couplings are designed and manufactured to meet API 671 as a standard.

Hubs, sleeves and spacers are heat-treated alloy steel while the flexible elements are a series of corrosion resistant, high strength, stainless steel discs coated with Koplon*. Accessories are high quality steel fasteners.

As a result of factory assembly, interference fit pilots and tight fitting bolts, the couplings retain their balance integrity even after repeated reassembly.

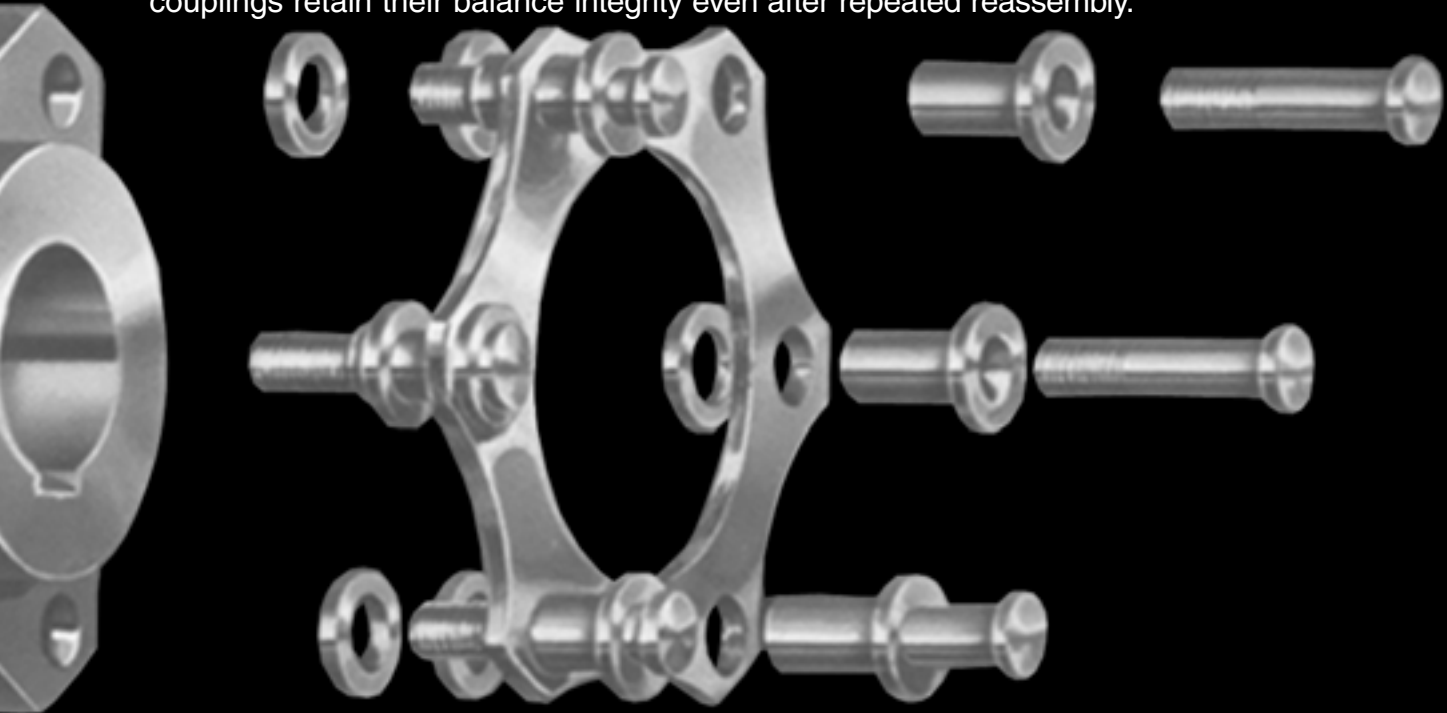

Design Options

The Kop-Flex coupling is available in four standard designs to accommodate operating conditions. The full featured RM and its economical alternative, the RZ, allow the lowest overhung moment available. The marine styles, the interlocking flange MS and the standard MP allow for installing and removing factory-assembled center sections without removing the rigid hubs. These hubs also accommodate larger bore capacities.

The "fail-safe" interlocking design available on the RM and MS styles (wherein the sleeve and hub or adapter flanges mate for a redundant connection) so there will be no instantaneous separation of the driving and driven shafts in the unlikely event of a disc pack failure.

Special designs, such as non-standard adapters to mate with integral flanges, are readily available. In addition, special materials such as titanium spacers or Inconel* disc packs are also available. Please consult Kop-Flex.

*Koplon is a trademark and/or a trade name of E. I. du Pont de Nemours and Company.

This trade name, trademark and/or registered trademark is used herein for product comparison purposes only, is the property of its respective owner and is not owned or controlled by Emerson Power Transmission Corporation. Emerson Power Transmission does not represent or warrant the accuracy of this document.

The Flexible Disc Pack

The Flexible Disc Pack is the heart of the Kop-Flex High Performance coupling and transmits torque while accommodating axial, offset and angular misalignment.

The Flexible Disc Pack is a series of precision manufactured discs assembled with washers and bushings into a unitized pack. The disc material is special, high strength, 301 stainless steel and each disc is Koplon*-coated, to help prevent fretting corrosion. Alternate disc materials, such as Inconel, are available; consult Kop-Flex.

The discs have a “waisted” or “scalloped” link design. This results in increased flexibility and subsequent lower reaction forces on the connected equipment bearings. Further, stress distribution is uniform, which allows for increased misalignment capability and lower fatigue stresses on the discs. The scalloping also reduces weight and inertia.

The discs are designed for infinite life with a factor of safety. Under loading, the disc pack is exposed to constant stresses due to torque, centrifugal force, axial misalignment and pretension and to alternating stresses due to angular and offset misalignment.

The combined effect of these stresses is plotted on a modified Goodman diagram, which gives the disc material endurance limit boundaries. Generally, at normal operating conditions, and at maximum angular misalignment and axial displacement ratings, the discs operate with a nominal safety factor of 2.

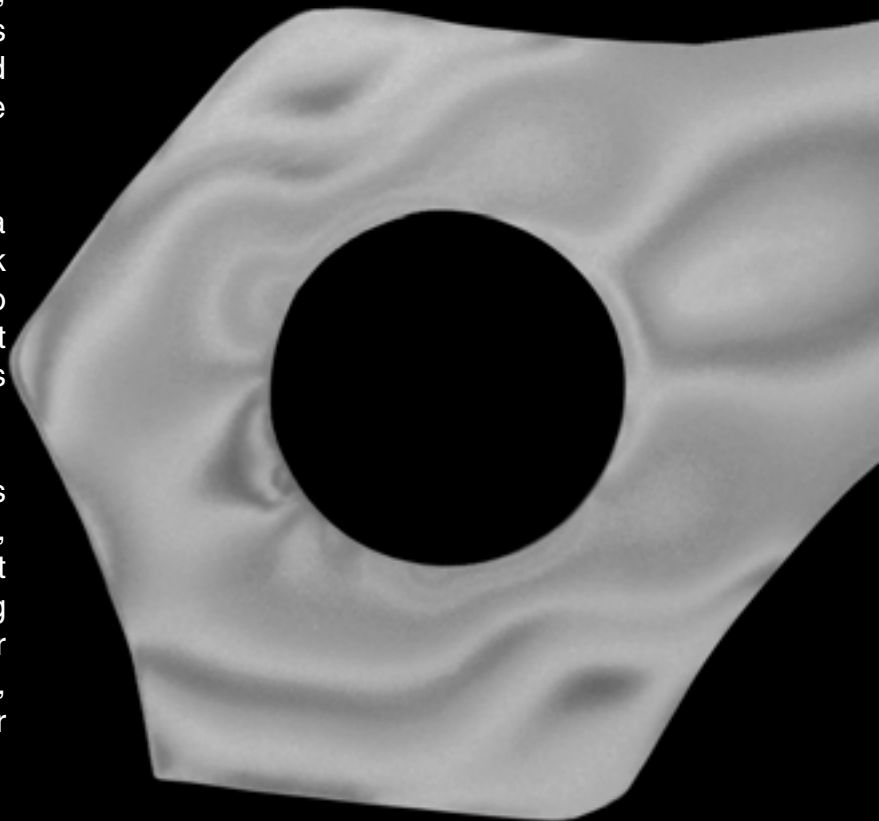
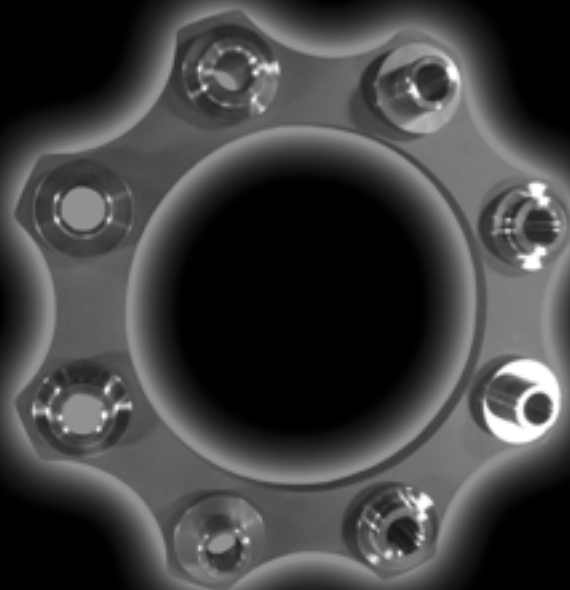

*Koplon is a Teflon based (PTFE) material of proprietary formulation.

*Koplon and Teflon are trademarks and/or trade names of E. I. du Pont de Nemours and Company.

These trade names, trademarks and/or registered trademarks of others are used herein for product comparison purposes only, are the property of their respective owners and are not owned or controlled by Emerson Power Transmission Corporation. Emerson Power Transmission does not represent or warrant the accuracy of this document.

Kop-Flex Disc Advantages

- More flexibility
- Lower reaction forces
- 301 stainless steel
- Koplon* coating
- Uniform stress distribution
- Reduced weight and inertia
- Unitized assembly

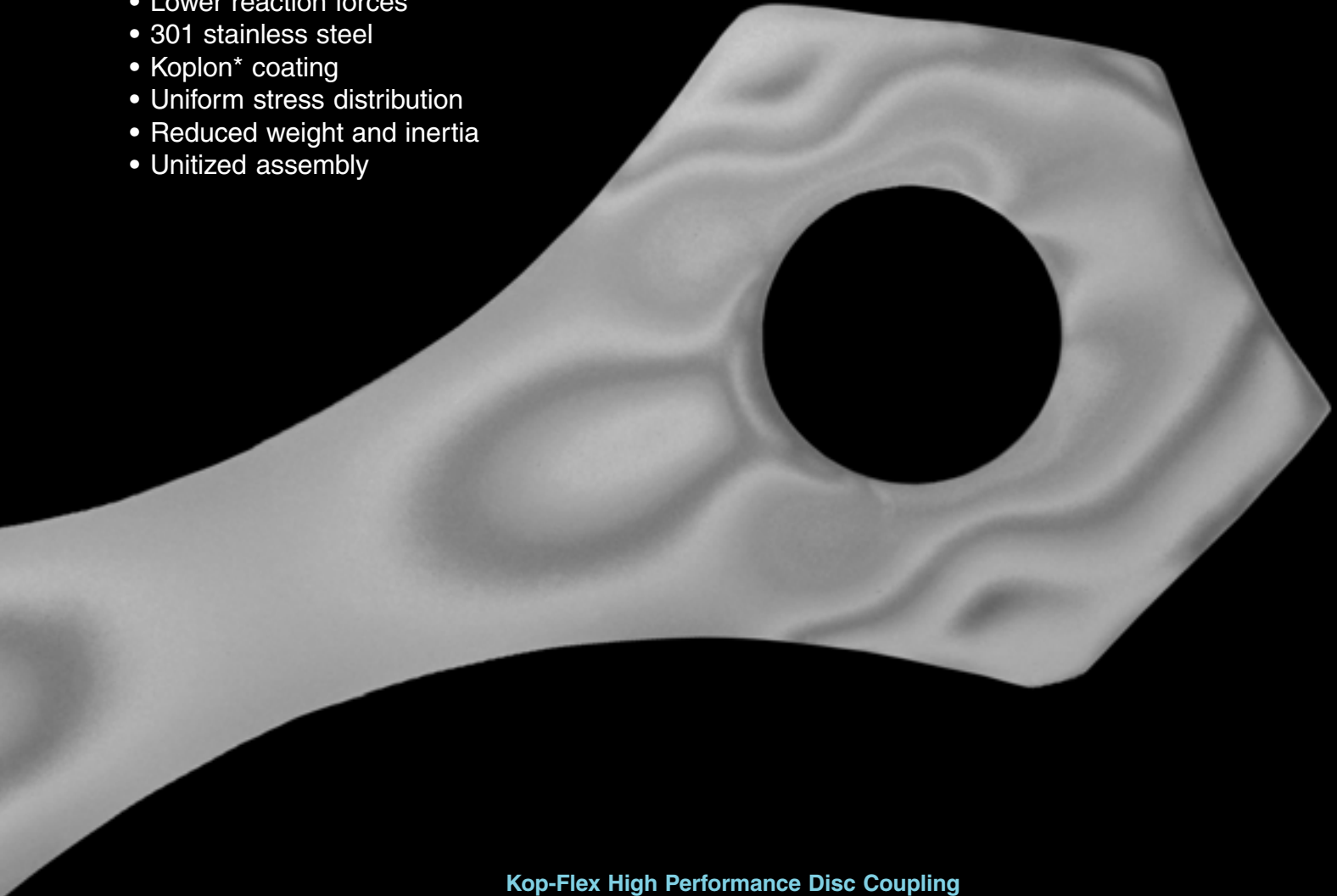

**Kop-Flex High Performance Disc Coupling
Modified Goodman Diagram
Typical Application**

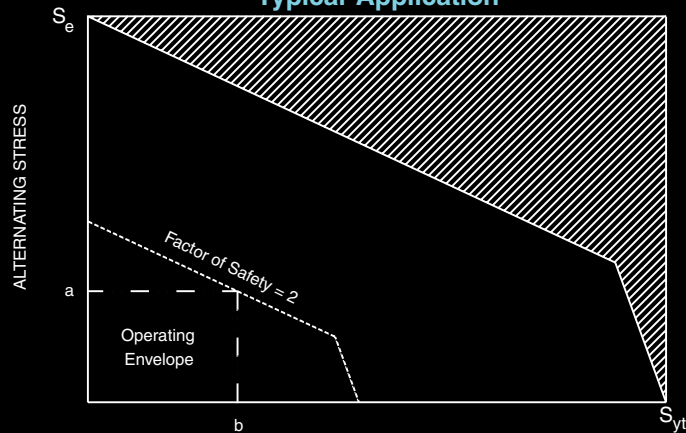

a = 100% angular misalignment
b = Normal operating HP and speed + 100% axial misalignment

*Koplon is a Teflon based (PTFE) material of proprietary formulation.

*Koplon and Teflon are trademarks and/or trade names of E. I. du Pont de Nemours and Company.

These trade names, trademarks and/or registered trademarks of others are used herein for product comparison purposes only, are the property of their respective owners and are not owned or controlled by Emerson Power Transmission Corporation. Emerson Power Transmission does not represent or warrant the accuracy of this document.

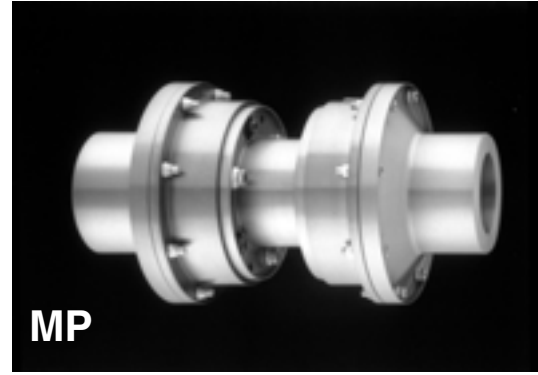
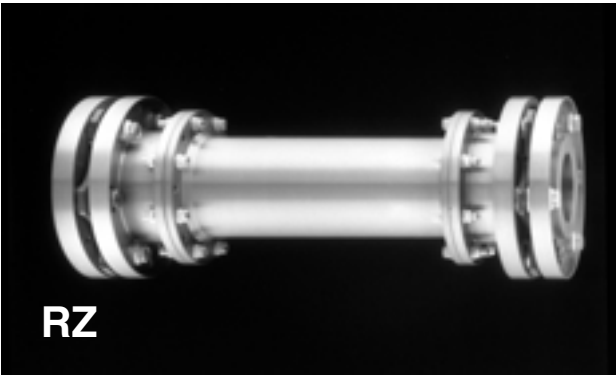
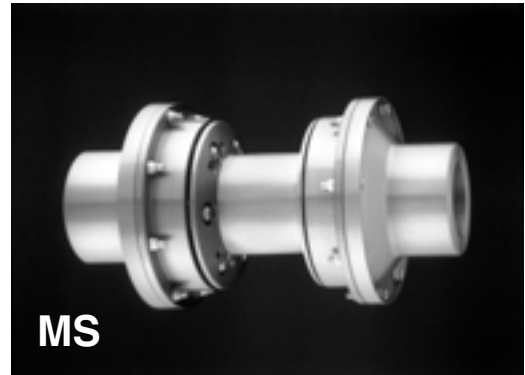
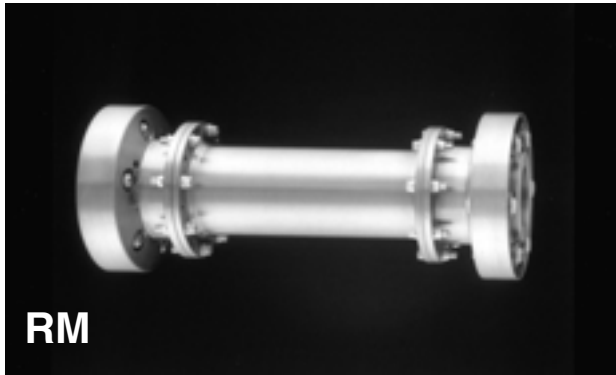

Kop-Flex High Performance Coupling Designs

RM Style

- Typical Applications:
 - SYN Gas and other high speed ammonia plant trains
 - High speed turbine to compressor applications where reduced over-hung moment is critical
- Full featured high performance disc coupling
- Lowest overhung moment available
- Reduced windage design
- Interlocking flanges for additional safety and momentary torque capacity

RZ Style

- Typical Applications
 - Motor driven gearbox to compressor applications
 - Boiler feed pumps
 - Medium speed turbine to compressor applications
- Reduced moment, high performance disc coupling
- An economical alternative to the full featured “RM” style
- Non-interlocking flanges

MS Style

- Typical Applications
 - Marine drives
 - Turbine to generator sets
 - Turbine to gearbox/compressor drives
- Marine style, high performance disc coupling
- Interlocking flanges for additional safety and momentary torque capacity
- Flange mounted, removable center section can mount to either rigid hub or an integral flange
- Rigid hubs allow for larger bore capacity
- Reduced windage design

MP Style

- Typical applications
 - Turbine to generator sets
 - Auxiliary drives
 - Turbine to gearbox/compressor drives
- Marine style, high performance disc coupling
- An economical alternative to the “MS” style
- Non-interlocking flanges
- Flange mounted, removable center section can mount to either rigid hub or an integral flange
- Center section or spacer safely encapsulated with anti-flail adapter extensions.
- Rigid hubs allow for larger bore capacity
- Reduced windage disc pack cover

The flexible disc pack is available in 3, 4, and 5-bolt designs to meet various torque and misalignment conditions. The 3-bolt design allows for the most axial and angular misalignment due to the increased flexibility of longer disc links between each bolt.

Where high torque capacity is required with smaller angular and axial misalignments, such as between a motor and generator subject to short circuit torques, 5-bolt interlocking frame designs can be used.

For optimum torque carrying capacity and flexibility, the standard 5-bolt design is the preferred choice.

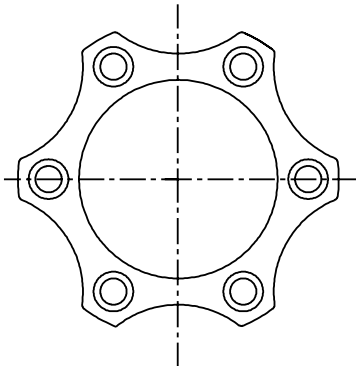

3-Bolt

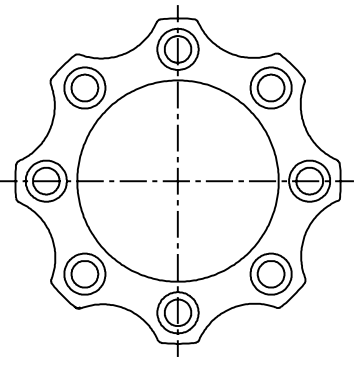

4-Bolt

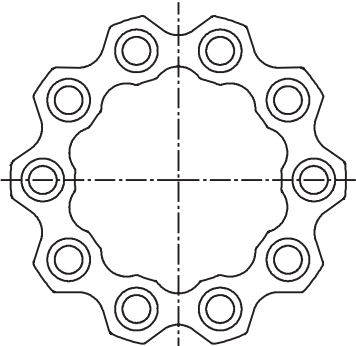

5-Bolt

Improved Scalloped Design

NOTE: The last digit in a coupling's size designation determines whether it is a 3, 4, or 5-bolt design. For example a size 153 coupling is a 3-bolt design.

1. Select the coupling style and the appropriate service factor as listed below. The coupling selection should have a maximum, continuous rating that will accommodate the service factor and the normal continuous torque. The 5-bolt design is considered standard and should be selected whenever possible.

Note: To account for off-design fluctuating or continuous torques, a service factor should be used. API671 recommends 1.5; Kop-Flex also recommends 1.5 minimum for general turbomachinery applications.

Service Factors

Generally constant torque with off-design conditions (turbines, centrifugal compressors, gearboxes)	1.50
API 671 - 3rd edition	1.50
Moderate torque fluctuations (large fans, screw compressors, etc.)	2.00

2. Check the maximum bore capacity and the peak torque capacity of the coupling selected.
3. Check the axial and angular misalignment requirements of the application (thermal growth, etc.)
4. Check that the coupling will not interfere with the coupling guard, piping, or the equipment housing and that it will fit in the shaft separation required.

Coupling selection, windage data, and lateral critical speeds can be supplied by Kop-Flex if necessary.

Example 1: Gas Turbine/Speed Reducer

(1.5 service factor, reduced moment required; interlocking flanges not required)

Turbine shaft—3" tapered, keyless hydraulic

Gearbox shaft—3" tapered, keyed

18" shaft separation

Normal load: 5000 HP at 5000 RPM

Service factor = 1.5

HP/100 RPM required = (HP/RPM) x 100 x SF (service factor) =

$$\frac{5000}{5000} \times 100 \times 1.5 = 150 \text{ HP/100RPM}$$

Continuous torque capacity required (lb-in.)

$$(\text{HP} \times 63025 / \text{RPM}) \times \text{SF} = 94540 \text{ lb-in.}$$

Selection: #254 RZ Reduced Moment Style

Example 2: Steam Turbine/Centrifugal Compressor

(API 671 required: 1.5 service factor; reduced moment required on compressor shaft, interlocking flanges requested; 1/5° angular misalignment capacity required)

Turbine shaft—8" tapered, keyless hydraulic

Compressor shaft—6" tapered, keyless hydraulic

24" shaft separation

Normal load: 49000 HP at 6000 RPM

Continuous torque capacity required (lb-in.)

$$\frac{49000}{6000} \times 63025 \times 1.5 = 772100 \text{ lb-in.}$$

Selection: #455 MS/#504 RM
Marine style (MS) on turbine (driving) shaft and interlocking feature
Reduced moment (RM) style on compressor (driven) shaft and interlocking feature

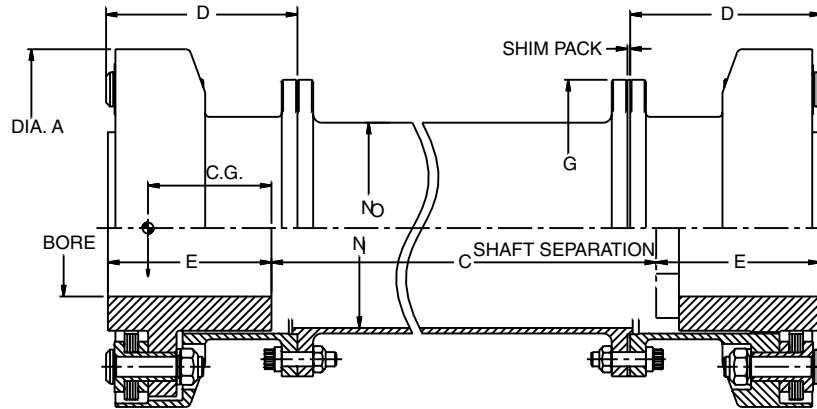

RM Coupling Selection Data

Size	① Nominal Bore Capacity (in)	* Max. Continuous Coupling Rating HP/100 RPM	* Max. Continuous Torque Rating (in-lbs)	** Max. Momentary Torque Rating (in-lbs)	Maximum Speed RPM	③ Total Weight (lbs)	④ Total WR ² (lb-in ²)	⑤ Half Coupling C.G. (in)	⑥ ⑦ Torsional Stiffness K (lb-in/rad x 10 ⁶)	Spacer Tube/in		
										K (lb-in x 10 ⁶) rad	Weight (lbs)	WR ² (lb-in ²)
103	1.5	19	12000	29000	34300	12.6	20	1.74	0.36	9.8	0.23	0.24
153	2.0	48	30000	72000	28600	19.8	59.8	1.83	0.94	30.1	0.32	0.72
154	2.0	72	47000	112000	28600	23.6	80	1.85	0.99	30.1	0.32	0.72
203	2.5	88	56000	134000	23800	32.6	149	2.29	1.8	63.7	0.43	1.53
204	2.5	132	83000	198000	23800	36.3	178	2.31	1.9	63.7	0.43	1.53
253	3.0	135	85000	203000	19900	51.5	355	2.69	3.0	102	0.48	2.43
254	3.0	210	132000	315000	19900	55.5	388	2.71	3.1	102	0.48	2.43
303	3.5	219	138000	329000	17100	78.0	689	3.11	5.7	219	0.75	5.24
304	3.5	331	209000	498000	17100	86.0	808	3.14	6.0	219	0.75	5.24
353	4.0	343	216000	515000	14900	116	1370	3.50	9.2	383	1.00	9.18
354	4.0	517	326000	778000	14900	129	1620	3.53	10	383	1.00	9.18
355	4.0	647	407000	971000	12800	151	1960	3.50	11	475	1.26	11.40
403	4.5	501	315000	751000	13100	167	2570	3.85	14	637	1.33	15.3
404	4.5	750	473000	1128000	13100	185	3020	3.89	15	637	1.33	15.3
405	4.5	938	591000	1410000	11300	203	3350	3.83	15	790	1.67	18.9
453	5.0	660	416000	992000	11900	221	4030	4.43	20	980	1.67	23.5
454	5.0	1020	642000	1531000	11900	248	4760	4.40	23	980	1.67	23.5
455	5.0	1270	801000	1910000	10100	260	5,000	4.37	23	1,204	2.08	28.8
504	5.5	1290	813000	1939000	10900	297	7090	4.44	26	1300	1.83	31.2
505	5.5	1610	1016000	2423000	10900	313	7440	4.45	29	1740	2.50	41.6
554	6.0	1720	1082000	2581000	9900	438	12800	5.36	34	1880	2.23	44.9
555	6.0	2150	1354000	3229000	9900	448	13000	5.37	37	2440	2.96	58.4
604	6.5	2190	1379000	3289000	9200	518	17100	5.94	47	2620	2.67	62.7
605	6.5	2730	1724000	4112000	9200	543	17900	5.97	51	3330	3.45	79.6

RM Dimensional Data

Size	A	D	G	No	Ni	Nominal Bore ^① Capacity	② E Std.	MAX O	③ MIN C	Size
103	4.06	2.75	3.69	2.16	1.91	1.5	2.25	2.25	3.65	103
153/154	5.56	2.94	4.56	3.12	2.88	2.0	2.44	3.00	3.88	153/154
203/204	6.56	3.53	5.47	3.88	3.62	2.5	3.03	3.75	4.62	203/204
253/254	7.84	4.16	6.50	4.62	4.38	3.0	3.59	4.50	4.88	253/254
303/304	9.09	4.69	7.38	5.44	5.12	3.5	4.19	5.25	5.80	303/304
353/354/355	10.47	5.25	8.50	6.25	5.88/5.78	4.0	4.7	6.00	5.88	353/354/355
403/404/405	11.94	6.00	9.47	7.00	6.56/6.44	4.5	5.31	6.75	6.88	403/404/405
453/454/455	13.06	6.60	10.56	7.75	7.25/7.12	5.0	6.03	7.50	7.56	453/454/455
504/505	14.31	7.25	11.44	8.50	8.00/7.81	5.5	6.75	8.25	8.56	504/505
554/555	15.75	8.03	12.62	9.25	8.69/8.50	6.0	7.41	9.00	8.68	554/555
604/605	17.00	8.62	13.50	10.00	9.38/9.19	6.5	7.94	9.75	10.94	604/605

① Based on 1.5 hub O.D./ bore ratio; larger bores are possible, consult Kop-Flex for specific applications.
 ② Can be reduced for smaller bores with shorter bore lengths.
 ③ Minimum shaft separation for standard (E) bore lengths and installation without disturbing connected equipment.
 ④ Data based on coupling with 18" shaft separation and nominal tapered bores for keyless hydraulic shaft connections; data can be changed to meet specific requirements.
 ⑦ Kop-Flex torsional stiffness calculation method.
 * API 3rd Edition Rating (0.2 degrees misalignment capacity with full axial misalignment capacity).
 ** Maximum momentary torque capacity as defined by API 671 is used to evaluate applications such as generators with short circuit torques.
 Extra capacity is provided by interlocking flanges. Consult Kop-Flex.
 Other large non-continuous torques, such as synchronous and induction motor start-up torques, are evaluated using low cycle fatigue.
 Specifications and selection data are subject to change without notice.

Conversion Factors (U.S. Customary to Metric)

1 lb (mass)	=	0.4536kg
1 inch	=	25.4 mm
1 in-lb	=	0.113Nm
1 HP	=	0.7457 kW
1 lb-in ²	=	0.000293kgm ²

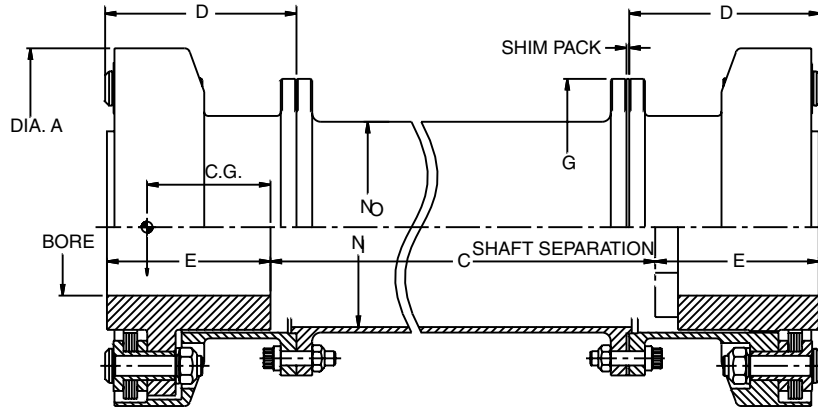

RM Coupling Selection Data

Size	① Nominal Bore Capacity (mm)	* Max. Continuous Coupling Rating (kW/RPM)	* Max. Continuous Torque Rating (kNm)	** Max. Momentary Torque Rating (kNm)	Maximum Speed (RPM)	⑥ Total Weight (kg)	⑥ Total WR ² (kgm ²)	⑥ Half Coupling C.G. (mm)	⑥ ⑦ Torsional Stiffness K (MNm/rad)	Spacer Tube		
										K (MNm/rad)/m	Weight (kg)/m	WR ² (kgm ²)/m
103	38	0.14	1.38	3.27	34300	5.72	.006	44	.04	.03	4.11	.003
153	51	0.36	3.39	8.05	28600	8.98	.018	46	.11	.09	5.71	.008
154	51	0.54	5.27	12.5	28600	10.7	.023	47	.11	.09	5.71	.008
203	64	0.65	6.27	14.9	23800	14.8	.044	58	.20	.18	7.68	.018
204	64	0.99	9.41	22.4	23800	16.5	.052	59	.21	.18	7.68	.018
253	76	1	9.66	23	19900	23.5	.104	68	.34	.29	8.57	.028
254	76	1.6	15	35.4	19900	25.1	.114	69	.35	.29	8.57	.028
303	89	1.6	16	37	17100	35.4	.202	79	.64	.63	13.4	.060
304	89	2.5	24	56	17100	39.0	.237	80	.68	.63	13.4	.060
353	102	2.6	24	58.1	14900	52.6	.401	89	1.0	1.10	17.9	.106
354	102	3.9	37	87.6	14900	58.5	.475	90	1.1	1.10	17.9	.106
355	102	4.9	46	110	12800	68.0	.570	89	1.2	1.40	22.5	.132
403	114	3.8	36	84.7	13100	75.8	.753	98	1.6	1.83	23.8	.176
404	114	5.6	53	127	13100	83.9	.885	99	1.7	1.83	23.8	.176
405	114	7	67	159	11300	92.0	.980	97	1.7	2.20	29.5	.216
453	127	5	47	112	11900	100	1.18	113	2.3	2.81	29.8	.271
454	127	7.6	73	172	11900	112	1.39	112	2.6	2.81	29.8	.271
455	127	9.5	91	215	10100	118	1.46	111	2.6	3.50	37.2	.333
504	140	9.7	92	218	10900	135	2.08	113	2.9	3.73	32.7	.360
505	140	12	114	272	10900	142	2.18	113	3.3	4.99	44.6	.480
554	152	13	122	290	9900	199	3.75	136	3.9	5.40	39.8	.518
555	152	16	153	364	9900	203	3.81	136	4.2	7.00	52.9	.674
604	165	16	155	370	9200	235	5.01	151	5.3	7.52	47.7	.723
605	165	21	194	462	9200	246	5.24	152	5.8	9.56	61.6	.918

RM Dimensional Data

Size	A	D	G	No	Ni	Nominal Bore ① Capacity	② E Std	MAX O	③ MIN C	Size
103	103	70	94	55	49	38	57	57	93	103
153/154	141	75	116	79	73	51	62	76	99	153/154
203/204	167	90	139	99	92	64	77	95	117	203/204
253/254	199	106	165	117	111	76	91	114	124	253/254
303/304	231	119	187	138	130	89	106	133	147	303/304
353/354/355	257	133	216	159	149/147	102	119	152	149	353/354/355
403/404/405	303	152	241	178	167/164	114	135	171	175	403/404/405
453/454/455	332	168	268	197	184/181	127	153	191	192	453/454/455
504/505	363	184	291	216	203/198	140	171	210	217	504/505
554/555	400	204	321	235	221/216	152	188	229	220	554/555
604/605	432	219	343	254	238/233	165	202	248	278	604/605

① Based on 1.5 hub O.D./ bore ratio; larger bores are possible, consult Kop-Flex for specific applications.
 ② Can be reduced for smaller bores with shorter bore lengths.
 ③ Minimum shaft separation for standard (E) bore lengths and installation without disturbing connected equipment.
 ④ Data based on coupling with 18" shaft separation and nominal tapered bores for keyless hydraulic shaft connections; data can be changed to meet specific requirements.
 ⑤ Kop-Flex torsional stiffness calculation method.
 * API 3rd Edition Rating (0.2 degrees misalignment capacity with full axial misalignment capacity).
 ** Maximum momentary torque capacity as defined by API 671 is used to evaluate applications such as generators with short circuit torques.
 Extra capacity is provided by interlocking flanges. Consult Kop-Flex.
 Other large non-continuous torques, such as synchronous and induction motor start-up torques, are evaluated using low cycle fatigue.
 Specifications and selection data are subject to change without notice.

Conversion Factors

(U.S. Customary to Metric)

1 lb (mass)	=	0.4536kg
1 inch	=	25.4 mm
1 in-lb	=	0.113Nm
1 HP	=	0.7457 kW
1 lb-in ²	=	0.000293kgm ²

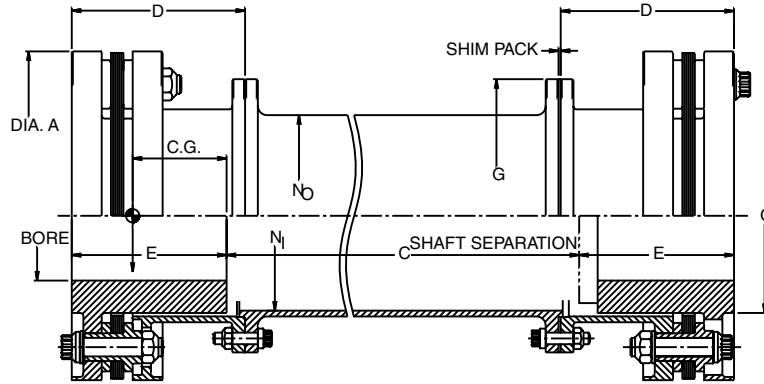

RZ Coupling Selection Data

Size	① Nominal Bore Capacity (in)	* Max. Continuous Coupling Rating HP/100 RPM	* Max. Continuous Torque Rating (in-lbs)	** Max. Momentary Torque Rating (in-lbs)	Maximum Speed RPM	⑥ Total Weight (lbs)	⑦ Total WR ² (lb-in ²)	⑧ Half Coupling C.G. (in)	⑨ Torsional Stiffness K (lb-in/rad x 10 ⁶)	Spacer Tube/in		
										K (lb-in x 10 ⁶) rad	Weight (lbs)	WR ² (lb-in ²)
103	1.5	19	12000	19000	34300	13.6	21	1.51	0.36	9.8	0.23	0.24
153	2.0	48	30000	48000	28600	22.1	72.7	1.63	0.90	30.1	0.32	0.72
154	2.0	72	47000	75000	28600	23.6	77	1.57	0.98	30.1	0.32	0.72
203	2.5	88	56000	89000	23800	34.6	163	2.08	1.7	63.7	0.43	1.53
204	2.5	132	83000	132000	23800	35.3	167	2.07	1.8	63.7	0.43	1.53
253	3.0	135	85000	135000	19900	52.5	354	2.42	2.9	102	0.48	2.43
254	3.0	210	132000	210000	19900	53.5	363	2.42	3.0	102	0.48	2.43
303	3.5	219	138000	219000	17100	81.1	732	2.84	5.6	219	0.75	5.24
304	3.5	331	209000	332000	17100	82.5	755	2.84	5.8	219	0.75	5.24
353	4.0	343	216000	343000	14900	121	1460	3.19	8.9	383	1.00	9.18
354	4.0	517	326000	518000	14900	124	1500	3.19	9.2	383	1.00	9.18
355	4	647	407000	647000	12800	129	1540	3.07	9.7	475	1.26	11.40
403	4.5	501	315000	501000	13100	174	2720	3.48	13	637	1.33	15.3
404	4.5	750	473000	752000	13100	178	2790	3.48	14	637	1.33	15.3
405	4.5	938	591000	940000	11300	186	2870	3.36	15	790	1.67	18.9
453	5.0	660	416000	661000	11900	229	4260	4.07	19	980	1.67	23.5
454	5.0	1020	642000	1021000	11900	237	4330	4.06	20	980	1.67	23.5
455	5	1270	801000	1274000	10100	244	4500	3.97	21	1204	2.08	28.8
504	5.5	1290	813000	1293000	10900	283	6530	3.95	25	1300	1.83	31.2
505	5.5	1610	1016000	1615000	10900	301	6950	3.95	28	1740	2.50	41.6
554	6.0	1720	1082000	1720000	9900	403	11000	4.79	33	1880	2.23	44.9
555	6.0	2150	1354000	2153000	9900	424	11600	4.80	36	2440	2.96	58.4
604	6.5	2190	1379000	2193000	9200	491	15600	5.41	46	2620	2.67	62.7
605	6.5	2730	1724000	2741000	9200	516	16400	5.41	49	3330	3.45	79.6
704	8.0	4130	2603000	4139000	7500	880	42100	6.61	93	6100	4.05	146
705	8.0	5160	3253000	5172000	7500	920	44400	6.62	99	7790	5.28	187
804	9.0	6120	3852000	6125000	6600	1250	76000	7.18	130	10100	5.28	241

RZ Dimensional Data

Size	A	D	G	No	Ni	Nominal Bore ^① Capacity	② E Std.	MAX O	③ MIN C	Size
103	3.88	2.75	3.69	2.25	2.00	1.5	2.25	2.12	3.65	103
153/154	5.38	2.94	4.56	3.12	2.88	2.0	2.44	3.00	3.88	153/154
203/204	6.38	3.53	5.47	3.88	3.62	2.5	3.03	3.75	4.62	203/204
253/254	7.62	4.16	6.50	4.62	4.38	3.0	3.59	4.50	4.88	253/254
303/304	8.88	4.69	7.38	5.44	5.12	3.5	4.19	5.25	5.80	303/304
353/354/355	10.12	5.25	8.50	6.25	5.88/5.78	4.0	4.7	6.00	5.88	353/354/355
403/404/405	11.50	6.00	9.47	7.00	6.56/6.44	4.5	5.31	6.75	6.88	403/404/405
453/454/455	12.62	6.60	10.56	7.75	7.25/7.12	5.0	6.03	7.50	7.56	453/454/455
504/505	13.88	7.25	11.44	8.50	8.00/7.81	5.5	6.75	8.25	8.56	504/505
554/555	15.12	8.03	12.62	9.25	8.69/8.50	6.0	7.41	9.00	8.68	554/555
604/605	16.50	8.62	13.50	10.00	9.38/9.19	6.5	7.94	9.75	10.94	604/605
704/705	20.25	10.50	16.00	12.38	11.62/11.38	8.0	9.81	12.00	11.76	704/705
804	22.88	11.88	18.12	13.94	13.06	9.0	11.12	13.50	12.38	804

① Based on 1.5 hub O.D./ bore ratio; larger bores are possible, consult Kop-Flex for specific applications.
 ② Can be reduced for smaller bores with shorter bore lengths.
 ③ Minimum shaft separation for standard (E) bore lengths and installation without disturbing connected equipment.
 ④ Data based on coupling with 18" shaft separation and nominal tapered bores for keyless hydraulic shaft connections; data can be changed to meet specific requirements.
 ⑤ Kop-Flex torsional stiffness calculation method.
 * API 3rd Edition Rating (0.2 degrees misalignment capacity with full axial misalignment capacity).
 ** Maximum momentary torque capacity as defined by API 671 is used to evaluate applications such as generators with short circuit torques.
 Extra capacity is provided by interlocking flanges. Consult Kop-Flex.
 Other large non-continuous torques, such as synchronous and induction motor start-up torques, are evaluated using low cycle fatigue.

Conversion Factors (U.S. Customary to Metric)

1 lb (mass)	=	0.4536kg
1 inch	=	25.4 mm
1 in-lb	=	0.113Nm
1 HP	=	0.7457 kW
1 lb-in ²	=	0.000293kgm ²

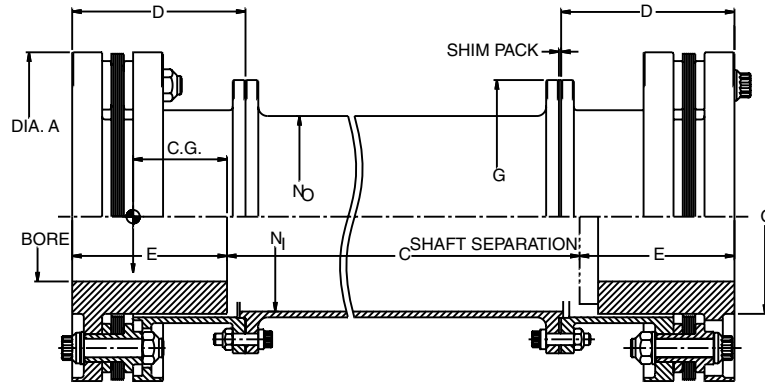

RZ Coupling Selection Data

Size	① Nominal Bore Capacity (mm)	* Max. Continuous Coupling Rating (kW/RPM)	* Max. Continuous Torque Rating (kNm)	** Max. Momentary Torque Rating (kNm)	Maximum Speed (RPM)	⑥ Total Weight (kg)	⑥ Total WR ² (kgm ²)	⑥ Half Coupling C.G. (mm)	⑥ ⑦ Torsional Stiffness K (MNm/rad)	Spacer Tube		
										K (MNm/rad)/m	Weight (kg)/m	WR ² (kgm ²)/m
103	38	0.14	1.38	2.19	34300	6.17	.006	38	.04	.03	4.11	.003
153	51	0.36	3.39	5.39	28600	10.0	.021	41	.10	.09	5.71	.008
154	51	0.54	5.27	8.38	28600	10.7	.023	40	.11	.09	5.71	.008
203	64	0.65	6.27	9.97	23800	15.7	.048	53	.19	.18	7.68	.018
204	64	0.99	9.41	15	23800	16.0	.049	53	.20	.18	7.68	.018
253	76	1	9.66	15.4	19900	23.8	.104	61	.33	.29	8.57	.028
254	76	1.6	15	23.7	19900	24.3	.106	61	.34	.29	8.57	.028
303	89	1.6	16	24.6	17100	36.8	.214	72	.63	.63	13.4	.060
304	89	2.5	24	37.4	17100	37.4	.221	72	.66	.63	13.4	.060
353	102	2.6	24	38.8	14900	54.9	.428	81	1.0	1.10	17.9	.106
354	102	3.9	37	58.7	14900	56.2	.440	81	1.0	1.10	17.9	.106
355	102	4.9	46	73.3	12800	58.5	.451	78	1.1	1.40	22.5	.132
403	114	3.8	36	56.6	13100	78.9	.797	88	1.6	1.83	23.8	.176
404	114	5.6	53	84.9	13100	80.7	.817	88	1.6	1.83	23.8	.176
405	114	7	67	106	11300	84.4	.840	85	1.6	2.20	29.5	.216
453	127	5	47	74.9	11900	104	1.25	103	2.1	2.81	29.8	.271
454	127	7.6	73	115	11900	106	1.28	103	2.3	2.81	29.8	.271
455	127	9.5	91	144	10100	111	1.32	101	2.4	3.50	37.2	.333
504	140	9.7	92	146	10900	128	1.91	100	2.8	3.73	32.7	.360
505	140	12	114	181	10900	137	2.04	100	3.5	4.99	44.6	.480
554	152	13	122	194	9900	183	3.22	122	3.7	5.40	39.8	.518
555	152	16	153	243	9900	192	3.40	122	4.1	7.00	52.9	.673
604	165	16	155	246	9200	223	4.57	137	5.2	7.52	47.7	.723
605	165	21	194	308	9200	234	4.81	137	5.5	9.56	61.6	.918
704	203	31	294	467	7500	399	12.3	168	11	17.5	72.3	1.68
705	203	39	367	584	7500	417	13.0	168	11	22.4	94.3	2.16
804	229	46	435	692	6600	567	22.3	182	15	28.99	94.3	2.78

RZ Dimensional Data

Size	A	D	G	No	Ni	Nominal Bore ① Capacity	② E Std	MAX O	③ MIN C	Size
103	99	70	94	57	51	38	57	54	93	103
153/154	137	75	116	79	73	51	62	76	99	153/154
203/204	162	90	139	99	92	64	77	95	117	203/204
253/254	194	106	165	117	111	76	91	114	124	253/254
303/304	226	119	187	138	130	89	106	133	147	303/304
353/354/355	257	133	216	159	149/147	102	119	152	149	353/354/355
403/404/405	292	152	241	178	167/164	114	135	171	175	403/404/405
453/454/455	321	168	268	197	184/181	127	153	191	192	453/454/455
504/505	353	184	291	216	203/198	140	171	210	217	504/505
554/555	384	204	321	235	221/216	152	188	229	220	554/555
604/605	419	219	343	254	238/233	165	202	248	278	604/605
704/705	514	267	406	314	295/289	203	249	305	299	704/705
804	581	302	460	354	332	229	282	343	314	804

- ① Based on 1.5 hub O.D./ bore ratio; larger bores are possible, consult Kop-Flex for specific applications.
- ② Can be reduced for smaller bores with shorter bore lengths.
- ③ Minimum shaft separation for standard (E) bore lengths and installation without disturbing connected equipment.
- ④ Data based on coupling with 18" shaft separation and nominal tapered bores for keyless hydraulic shaft connections; data can be changed to meet specific requirements.
- ⑤ Kop-Flex torsional stiffness calculation method.
- * API 3rd Edition Rating (0.2 degrees misalignment capacity with full axial misalignment capacity).
- ** Maximum momentary torque capacity as defined by API 671 is used to evaluate applications such as generators with short circuit torques.

Extra capacity is provided by interlocking flanges. Consult Kop-Flex.
Other large non-continuous torques, such as synchronous and induction motor start-up torques, are evaluated using low cycle fatigue.

Conversion Factors (U.S. Customary to Metric)

1 lb (mass)	=	0.4536kg
1 inch	=	25.4 mm
1 in-lb	=	0.113Nm
1 HP	=	0.7457 kW
1 lb-in ²	=	0.000293kgm ²

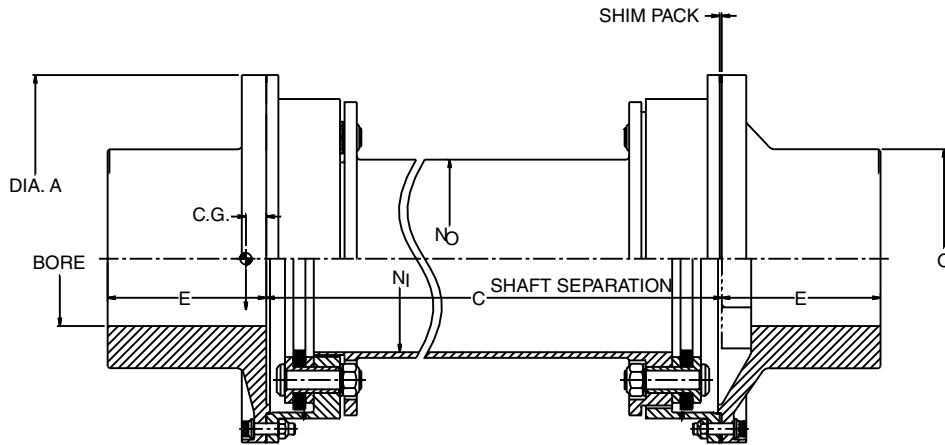

MS Coupling Selection Data

Size	① Nominal Bore Capacity (in)	* Max. Continuous Coupling Rating HP/100 RPM	* Max. Continuous Torque Rating (in-lbs)	** Max. Momentary Torque Rating (in-lbs)	Maximum Speed RPM	⑥ Total Weight (lbs)	⑥ Total WR ² (lb-in ²)	⑥ Half Coupling C.G. (in)	⑥ ⑦ Total Stiffness K (lb-in/rad x 10 ⁶)	Spacer Tube/in		
										K (lb-in x 10 ⁶)rad	Weight (lbs)	WR ² (lb-in ²)
103	2.5	19	12000	29000	27700	18.8	52	0.13	0.52	12.1	0.21	0.29
153	3.5	48	30000	72000	23100	32.9	150	0.18	1.4	41.5	0.38	0.99
154	3.5	72	47000	112000	23100	34.7	134	0.18	1.7	41.5	0.38	0.99
203	4.0	88	56000	134000	20200	47.2	291	0.36	2.4	71.3	0.43	1.71
204	4.0	132	83000	198000	20200	47.5	293	0.36	2.6	71.3	0.43	1.71
253	5.0	135	85000	203000	16900	75.3	669	0.41	4.3	129	0.55	3.10
254	5.0	210	132000	315000	16900	76.2	678	0.41	4.8	129	0.55	3.10
303	6.0	219	138000	329000	14800	110	678	0.46	8.0	252	0.77	6.04
304	6.0	331	209000	498000	14800	112	1310	0.45	8.9	252	0.77	6.04
353	6.5	343	216000	515000	12800	164	2590	0.44	13	458	1.06	11.0
354	6.5	517	326000	778000	12800	167	2620	0.42	15	458	1.06	11.0
355	6.5	647	407000	971000	12800	166	2570	0.37	15	536	1.25	12.8
403	7.5	501	315000	751000	11300	235	4810	0.40	19	769	1.41	18.4
404	7.5	750	473000	1128000	11300	238	4800	0.39	23	769	1.41	18.4
405	7.5	938	591000	1410000	11300	235	4720	0.34	28	769	1.40	18.4
453	8.5	660	416000	992000	10100	317	7960	0.58	27	1190	1.78	28.5
454	8.5	1020	642000	1531000	10100	322	8080	0.56	33	1190	1.78	28.5
455	8.5	1270	801000	1910000	10100	336	8450	0.47	22	1190	1.80	28.5
504	9.0	1290	813000	1939000	9400	399	11600	0.76	37	1560	1.94	37.2
505	9.0	1610	1016000	2423000	9400	407	11500	0.71	41	1560	1.94	37.2
554	10.0	1720	1082000	2581000	8400	552	20200	0.66	49	2250	2.37	53.9
555	10.0	2150	1354000	3229000	8400	564	20100	0.61	54	2250	2.37	53.9
604	11.0	2190	1379000	3289000	7900	668	28000	0.83	72	3160	2.84	75.6
605	11.0	2730	1724000	4112000	7900	683	27900	0.78	77	3160	2.84	75.6

MS Dimensional Data

Size	A	No	Ni	Typical Bore	② E Std.	MAX O	MIN C	Size
103	5.44	2.45	2.25	2.0	2.39	4.00	4.00	103
153/154	6.81	3.38	3.12	2.5	3.03	5.25	5.00	153/154
203/204	7.81	4.12	3.88	3.0	3.59	6.00	6.00	203/204
253/254	9.31	4.88	4.62	3.5	4.19	7.50	7.00	253/254
303/304	10.62	5.75	5.44	4.0	4.75	9.00	8.00	303/304
353/354/355	12.28	6.62	6.25/6.18	4.5	5.31	9.75	8.00	353/354/355
403/404/405	13.94	7.44	7.00	5.0	6.03	11.25	10.00	403/404/405
453/454/455	15.56	8.25	7.75	5.5	6.75	12.75	11.00	453/454/455
504/505	16.69	9.00	8.50	6.0	7.41	13.50	12.00	504/505
554/555	18.69	9.81	9.25	6.5	7.94	15.00	13.00	554/555
604/605	20.00	10.62	10.00	7.0	8.56	16.50	14.00	604/605

- ① Based on 1.5 hub O.D./ bore ratio; larger bores are possible, consult Kop-Flex for specific applications.
- ② Can be reduced for smaller bores with shorter bore lengths.
- ③ Minimum shaft separation for standard (E) bore lengths and installation without disturbing connected equipment.
- ④ Data based on coupling with 18" shaft separation and nominal tapered bores for keyless hydraulic shaft connections; data can be changed to meet specific requirements.
- ⑤ Kop-Flex torsional stiffness calculation method.
- * API 3rd Edition Rating (0.2 degrees misalignment capacity with full axial misalignment capacity).
- ** Maximum momentary torque capacity as defined by API 671 is used to evaluate applications such as generators with short circuit torques.

Extra capacity is provided by interlocking flanges. Consult Kop-Flex.
 Other large non-continuous torques, such as synchronous and induction motor start-up torques, are evaluated using low cycle fatigue.
 Specifications and selection data are subject to change without notice.

Conversion Factors (U.S. Customary to Metric)

1 lb (mass)	=	0.4536kg
1 inch	=	25.4 mm
1 in-lb	=	0.113Nm
1 HP	=	0.7457 kW
1 lb-in ²	=	0.000293kgm ²

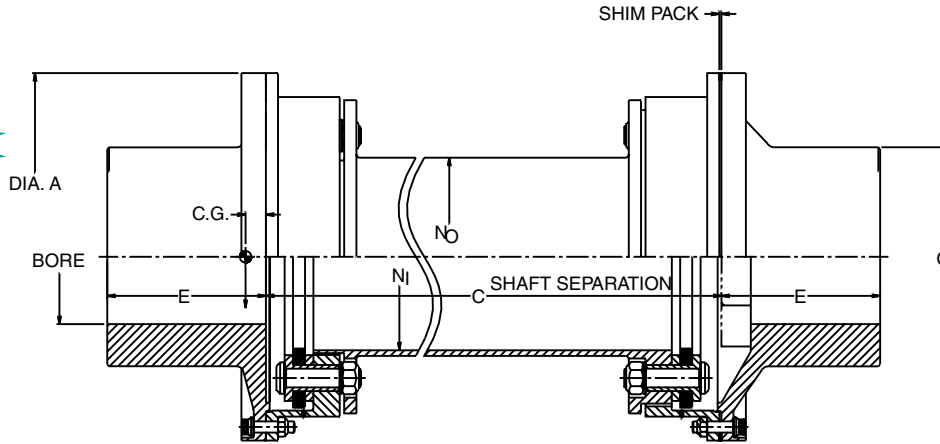

MS Coupling Selection Data

Size	① Nominal Bore Capacity (mm)	* Max. Continuous Coupling Rating (kW/RPM)	* Max. Continuous Torque Rating (kNm)	** Max. Momentary Torque Rating (kNm)	Maximum Speed (RPM)	⑥ Total Weight (kg)	⑥ Total WR ² (kgm ²)	⑥ Half Coupling C.G. (mm)	⑥ ⑦ Torsional Stiffness K (MNm/rad)	Spacer Tube		
										K (MNm/rad/m)	Weight (kg)m	WR ² (kgm ² /m)
103	64	0.14	1.38	3.27	27700	8.53	.015	3	.06	.04	3.75	.003
153	89	0.36	3.39	8.05	23100	14.9	.044	5	.16	.12	6.79	.011
154	89	0.54	5.27	12.5	23100	15.7	.039	5	.19	.12	6.79	.011
203	102	0.65	6.27	14.9	20200	21.4	.085	9	.27	.21	7.68	.020
204	102	0.99	9.41	22.4	20200	21.5	.086	9	.29	.21	7.68	.020
253	127	1	9.66	23	16900	34.1	.196	10	.49	.37	9.82	.036
254	127	1.6	15	35.4	16900	34.6	.199	10	.54	.37	9.82	.036
303	152	1.6	16	37	14800	49.9	.199	12	.90	.72	13.8	.070
304	152	2.5	24	56	14800	50.8	.384	11	1.0	.72	13.8	.070
353	165	2.6	24	58.1	12800	74.4	.759	11	1.5	1.31	19.0	.127
354	165	3.9	37	87.6	12800	75.8	1.06	11	1.6	1.31	19.0	.127
355	165	4.9	46	110	12800	75.3	.752	9	1.7	1.50	22.0	.145
403	191	3.8	36	84.7	11300	107	1.41	10	2.1	2.21	25.2	.212
404	191	5.6	53	127	11300	108	1.41	10	2.5	2.21	25.2	.212
405	191	7	67	159	11300	107	1.38	9	3.2	2.20	24.8	.209
453	216	5	47	112	10100	144	2.33	15	3.1	3.42	31.8	.329
454	216	7.6	73	172	10100	146	2.37	14	3.5	3.42	31.8	.329
455	216	9.5	91	215	10100	152	2.47	12	2.5	3.50	32.5	.337
504	229	9.7	92	218	9400	181	3.40	19	4.2	4.48	34.6	.429
505	229	12	114	272	9400	185	3.37	18	4.6	4.48	34.6	.429
554	254	13	122	290	8400	250	5.92	17	5.5	6.46	42.3	.622
555	254	16	153	364	8400	256	5.89	15	6.1	6.46	42.3	.622
604	279	16	155	370	7900	303	8.20	21	8.1	9.07	50.7	.872
605	279	21	194	462	7900	310	8.18	20	8.7	9.07	50.7	.872

MS Dimensional Data

Size	A	No	Ni	Typical Bore	② E Std	MAX O	MIN C	Size
103	138	62	57	51	61	102	102	103
153/154	183	86	79	64	77	133	127	153/154
203/204	198	105	99	76	91	152	152	203/204
253/254	236	124	117	89	106	191	178	253/254
303/304	270	146	138	102	121	229	203	303/304
353/354/355	312	168	159/157	114	135	248	203	353/354/355
403/404/405	354	189	178	127	153	286	254	403/404/405
453/454/455	395	210	197	140	171	324	279	453/454/455
504/505	424	229	216	152	188	343	305	504/505
554/555	475	249	235	165	202	381	330	554/555
604/605	508	270	254	178	217	419	356	604/605

- ① Based on 1.5 hub O.D./ bore ratio; larger bores are possible, consult Kop-Flex for specific applications.
 - ② Can be reduced for smaller bores with shorter bore lengths.
 - ③ Minimum shaft separation for standard (E) bore lengths and installation without disturbing connected equipment.
 - ④ Data based on coupling with 18" shaft separation and nominal tapered bores for keyless hydraulic shaft connections; data can be changed to meet specific requirements.
 - ⑦ Kop-Flex torsional stiffness calculation method.
 - * API 3rd Edition Rating (0.2 degrees misalignment capacity with full axial misalignment capacity).
 - ** Maximum momentary torque capacity as defined by API 671 is used to evaluate applications such as generators with short circuit torques.
- Extra capacity is provided by interlocking flanges. Consult Kop-Flex.
 Other large non-continuous torques, such as synchronous and induction motor start-up torques, are evaluated using low cycle fatigue.
 Specifications and selection data are subject to change without notice.

Conversion Factors (U.S. Customary to Metric)

1 lb (mass)	=	0.4536kg
1 inch	=	25.4 mm
1 in-lb	=	0.113Nm
1 HP	=	0.7457 kW
1 lb-in ²	=	0.000293kgm ²

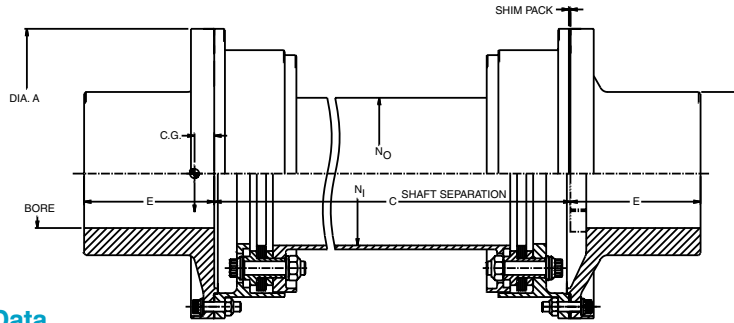

MP Coupling Selection Data

Size	Ø Nominal Bore Capacity (in)	* Max. Continuous Coupling Rating HP/100 RPM	* Max. Continuous Torque Rating (in-lbs)	** Max. Momentary Torque Rating (in-lbs)	Maximum Speed RPM	⑥ Total Weight (lbs)	⑥ Total WR ² (lb-in ²)	⑥ Half Coupling C. G. (in)	⑦ Total Stiffness K (lb-in/rad x 10 ⁶)	Spacer Tube/in		
										K (lb-in x 10 ⁶) rad	Weight (lbs)	WR ² (lb-in ²)
103	2.5	19	12000	19000	27700	18.5	52	-0.04	0.52	12.1	0.21	0.29
153	3.5	48	30000	48000	23100	33.3	154	0.01	1.4	41.5	0.38	0.99
154	3.5	72	47000	75000	23100	34.3	156	-0.01	1.7	41.5	0.38	0.99
203	4.0	88	56000	89000	20200	47.8	300	0.17	2.3	71.3	0.43	1.71
204	4.0	132	83000	132000	20200	48.5	304	0.14	2.6	71.3	0.43	1.71
253	5.0	135	85000	135000	16900	74.6	669	0.28	4.3	129	0.55	3.10
254	5.0	210	132000	210000	16900	75.5	679	0.25	4.7	129	0.55	3.10
303	6.0	219	138000	219000	14800	109	1290	0.31	7.9	252	0.77	6.04
304	6.0	331	209000	332000	14800	111	1320	0.28	8.8	252	0.77	6.04
353	6.5	343	216000	343000	12800	163	2590	0.26	13	458	1.06	11.0
354	6.5	517	326000	518000	12800	166	2640	0.22	14	458	1.06	11.0
355	6.5	647	407000	647000	12800	169	2670	0.16	15	458	1.06	11.0
403	7.5	501	315000	501000	11300	233	4730	0.23	19	769	1.41	18.4
404	7.5	750	473000	752000	11300	236	4800	0.19	21	769	1.41	18.4
405	7.5	938	591000	940000	11300	240	4840	0.12	24	769	1.41	18.4
453	8.5	660	416000	661000	10100	314	7940	0.44	27	1190	1.78	28.5
454	8.5	1020	642000	1021000	10100	318	8050	0.40	31	1190	1.78	28.5
455	8.5	1270	801000	1274000	10100	320	8050	0.35	29	1190	1.78	28.5
504	9.0	1290	813000	1293000	9400	392	11500	0.56	37	1560	1.94	37.2
505	9.0	1610	1016000	1615000	9400	399	11700	0.50	40	1560	1.94	37.2
554	10.0	1720	1082000	1720000	8400	554	20100	0.41	49	2250	2.37	53.9
555	10.0	2150	1354000	2153000	8400	553	20500	0.35	53	2250	2.37	53.9
604	11.0	2190	1379000	2193000	7900	655	27700	0.62	70	3160	2.84	75.6
605	11.0	2730	1724000	2741000	7900	666	28200	0.55	76	3160	2.84	75.6
655	12.0	3640	2293000	3646000	7000	877	44000	0.33	82	5035	3.60	121
704	13.0	4130	2603000	4139000	6500	1130	69400	0.65	150	7120	4.19	171
705	13.0	5160	3253000	5172000	6500	1150	71100	0.57	160	7120	4.19	171
755	14.0	5810	3663000	5824000	6300	1320	95300	0.46	206	10120	5.10	242
804	14.5	6120	3852000	6125000	6100	1590	140000	0.60	210	11100	5.16	266
805	14.5	7640	4814000	7654000	5900	1650	145000	0.42	250	13443	6.33	322
905	15.0	10330	6516000	10360000	5200	2050	185000	0.76	300	20193	8.64	484
1006	18.0	16440	10361000	18240000	4700	3760	501700	0.03	595	36055	11.00	863
1106	20.0	23800	15000000	26400000	3000	4950	795000	1.07	830	63830	17.00	1530

MP Dimensional Data

Size	A	No	Ni	Typical Bore	② E Std.	MAX O	MIN C	Size
103	5.44	2.45	2.25	2.0	2.39	4.00	4.00	103
153/154	6.81	3.38	3.12	2.5	3.03	5.25	5.00	153/154
203/204	7.81	4.12	3.88	3.0	3.59	6.00	6.00	203/204
253/254	9.31	4.88	4.62	3.5	4.19	7.50	7.00	253/254
303/304	10.62	5.75	5.44	4.0	4.75	9.00	8.00	303/304
353/354/355	12.28	6.62	6.25/6.18	4.5	5.31	9.75	8.00	353/354/355
403/404/405	13.94	7.44	7.00	5.0	6.03	11.25	10.00	403/404/405
453/454/455	15.56	8.25	7.75	5.5	6.75	12.75	11.00	453/454/455
504/505	16.69	9.00	8.50	6.0	7.41	13.50	12.00	504/505
554/555	18.69	9.81	9.25	6.5	7.94	15.00	13.00	554/555
604/605	20.00	10.62	10.00	7.0	8.56	16.50	14.00	604/605
655	22.00	11.92	11.22	8.0	9.50	18.00	15.50	655
704/705	24.00	13.12	12.38	8.5	10.38	19.50	17.00	704/705
755	25.60	14.16	13.32	9.0	10.50	20.75	18.00	755
804/805	26.88	14.75	13.94	9.5	11.59	21.75	19.00	804/805
905	30.00	15.60	14.30	10.0	12.00	22.50	20.00	905
1006	34.44	18.25	16.75	13.0	14.00	28.00	24.50	1006
1106	37.88	20.00	18.00	15.0	16.00	31.00	29.50	1106

- ① Based on 1.5 hub O.D./ bore ratio; larger bores are possible, consult Kop-Flex for specific applications.
- ② Can be reduced for smaller bores with shorter bore lengths.
- ③ Minimum shaft separation for standard (E) bore lengths and installation without disturbing connected equipment.
- ④ Data based on coupling with 18" shaft separation and nominal tapered bores for keyless hydraulic shaft connections; data can be changed to meet specific requirements.
- ⑦ Kop-Flex torsional stiffness calculation method.
- * API 3rd Edition Rating (0.2 degrees misalignment capacity with full axial misalignment capacity).
- ** Maximum momentary torque capacity as defined by API 671 is used to evaluate applications such as generators with short circuit torques.

Extra capacity is provided by interlocking flanges. Consult Kop-Flex.
Other large non-continuous torques, such as synchronous and induction motor start-up torques, are evaluated using low cycle fatigue.

Conversion Factors (U.S. Customary to Metric)

1 lb (mass)	=	0.4536kg
1 inch	=	25.4 mm
1 in-lb	=	0.113Nm
1 HP	=	0.7457 kW
1 lb-in ²	=	0.000293kgm ²

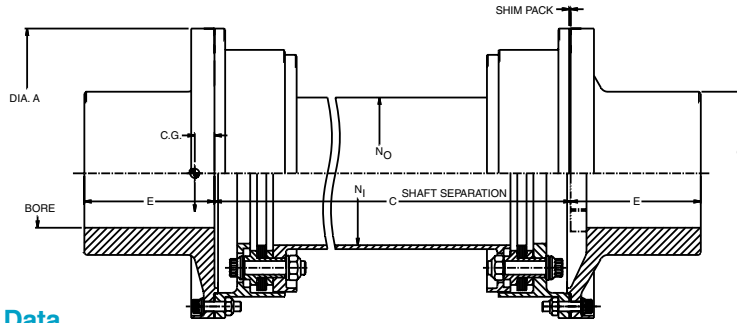

MP Coupling Selection Data

Size	① Nominal Bore Capacity (mm)	* Max. Continuous Coupling Rating (kW/RPM)	* Max. Continuous Torque Rating (kNm)	** Max. Momentary Torque Rating (kNm)	Maximum Speed (RPM)	③ Total Weight (kg)	③ Total WR* (kgm²)	④ Half Coupling C.G. (mm)	⑤ Torsional Stiffness K (MNm/rad)	Spacer Tube		
										K (MNm/rad)/m	Weight (kg/m)	WR² (kgm²)/m
103	64	0.14	1.38	2.19	27700	8.39	.015	-1	.06	.03	3.75	.003
153	89	0.36	3.39	5.39	23100	15.1	.045	0	.16	.12	6.79	.011
154	89	0.54	5.27	8.38	23100	15.6	.046	0	.19	.12	6.79	.011
203	102	0.65	6.27	9.97	20200	21.7	.088	4	.26	.21	7.68	.020
204	102	0.99	9.41	15	20200	22.0	.089	4	.29	.21	7.68	.020
253	127	1	9.66	15.4	16900	33.8	.196	7	.49	.37	9.82	.036
254	127	1.6	15	23.7	16900	34.2	.199	6	.53	.37	9.82	.036
303	152	1.6	16	24.6	14800	49.4	.378	8	.89	.72	13.8	.070
304	152	2.5	24	37.4	14800	50.4	.387	7	.99	.72	13.8	.070
353	165	2.6	24	38.8	12800	73.9	.759	7	1.5	1.31	18.9	.127
354	165	3.9	37	58.7	12800	75.3	.774	6	1.6	1.31	18.9	.127
355	165	4.9	46	73.3	12,800	76.7	0.8	4	1.7	1.5	22.0	.145
403	191	3.8	36	56.6	11300	106	1.39	6	2.1	2.21	25.2	.212
404	191	5.6	53	84.9	11300	107	1.41	5	2.4	2.21	25.2	.212
405	191	7	67	106	11300	109	1.4	3	2.7	2.2	24.8	.209
453	216	5	47	74.9	10100	142	2.33	11	3.1	3.41	31.8	.329
454	216	7.6	73	115	10100	144	2.36	10	3.5	3.41	31.8	.329
455	216	9.5	91	144	10100	145	2.4	9	3.3	3.5	32.5	.337
504	229	9.7	92	146	9400	178	3.37	14	4.2	4.48	34.6	.429
505	229	12	114	181	9400	181	3.43	13	4.5	4.48	34.6	.429
554	254	13	122	194	8400	251	5.89	10	5.5	6.46	42.3	.622
555	254	16	153	243	8400	251	6.01	9	6.0	6.46	42.3	.622
604	279	16	155	246	7900	297	8.12	16	7.9	9.07	50.7	.872
605	279	21	194	308	7900	302	8.26	14	8.6	9.07	50.7	.872
655	305	27	259	412	7000	398	12.9	8	9.3	14.6	65.1	.996
704	330	31	294	467	6500	513	20.3	17	17	20.4	74.8	1.97
705	330	39	367	584	6500	522	20.8	14	18	20.4	74.8	1.97
755	356	44	414	658	6300	599	27.9	12	23.3	29.9	94.5	2.880
804	359	46	435	692	6100	721	41.0	15	24	31.9	92.1	3.07
805	359	57	544	865	5900	748	42.5	11	28	38.6	113	3.74
905	381	77	736	1170	5200	930	54.2	19	34	58.0	154	5.58
1006	457	140	1300	2067	4700	1706	146.8	1	67.2	109.8	213.2	10.550
1106	508	200	1881	2991	3,000	2245	232.6	27	93.8	183.8	302.7	17.660

MP Dimensional Data

Size	A	No	Ni	Typical Bore	④ E Std	MAX O	MIN C	Size
103	138	62	57	51	61	102	102	103
153/154	173	86	79	64	77	133	127	153/154
203/204	198	105	99	76	91	152	152	203/204
253/254	236	124	117	89	106	181	178	253/254
303/304	270	146	138	102	121	229	203	303/304
353/354/355	312	168	159/157	114	135	248	203	353/354/355
403/404/405	354	189	178	127	153	286	254	403/404/405
453/454/455	395	210	197	140	171	324	279	453/454/455
504/505	424	229	216	152	188	343	205	504/505
554/555	475	249	235	165	202	381	330	554/555
604/605	508	270	254	178	217	419	356	604/605
655	559	303	285	203	241	457	394	655
704/705	610	333	314	216	264	495	432	704/705
755	650	360	338	229	267	527	457	755
804/805	683	375	354	241	294	552	483	804/805
905	762	396	363	254	305	572	508	905
1006	875	464	425	330	356	711	622	1006
1106	962	508	457	381	406	787	749	1106

- ① Based on 1.5 hub O.D./ bore ratio; larger bores are possible, consult Kop-Flex for specific applications.
- ② Can be reduced for smaller bores with shorter bore lengths.
- ③ Minimum shaft separation for standard (E) bore lengths and installation without disturbing connected equipment.
- ④ Data based on coupling with 18" shaft separation and nominal tapered bores for keyless hydraulic shaft connections; data can be changed to meet specific requirements.
- ⑤ Kop-Flex torsional stiffness calculation method.

* API 3rd Edition Rating (0.2 degrees misalignment capacity with full axial misalignment capacity).
 ** Maximum momentary torque capacity as defined by API 671 is used to evaluate applications such as generators with short circuit torques.
 Extra capacity is provided by interlocking flanges. Consult Kop-Flex.
 Other large non-continuous torques, such as synchronous and induction motor start-up torques, are evaluated using low cycle fatigue.

Conversion Factors (U.S. Customary to Metric)

1 lb (mass)	=	0.4536kg
1 inch	=	25.4 mm
1 in-lb	=	0.113Nm
1 HP	=	0.7457 kW
1 lb-in²	=	0.000293kgm²

AXIAL DATA

3 Bolt Series Axial Displacement

Size	Axial Displacement Max Continuous (in) ①	Max Force (lb)	Floating Weights (lb) 18" Shaft Separation			
			RM	RZ	MS	MP
103	±0.080	120	8.7	8.9	5.5	5
153	±0.115	270	13	13	10	10
203	±0.140	360	20	19	13	12
253	±0.170	430	30	27	19	17
303	±0.200	610	43	40	28	25
353	±0.230	870	63	59	41	36
403	±0.260	1100	90	82	58	51
453	±0.285	1300	120	110	71	62

ANGULAR DATA

3 Bolt Series

Size	Maximum Misalignment (degrees)	Bending Stiffness (lb-in/deg)
103	0.33	150
153	0.33	340
203	0.33	660
253	0.33	930
303	0.33	1410
353	0.33	2390
403	0.33	3690
453	0.33	4690

4 Bolt Series Axial Displacement

Size	Axial Displacement Max Continuous (in) ①	Max Force (lb)	Floating Weights (lb) 18" Shaft Separation			
			RM	RZ	MS	MP
154	±0.080	400	15	14	11	9.8
204	±0.100	570	23	19	13	12
254	±0.120	640	32	27	20	17
304	±0.140	900	48	41	30	25
354	±0.160	1300	73	60	44	37
404	±0.180	1700	100	84	62	53
454	±0.200	1900	140	110	77	64
504	±0.230	2500	160	130	96	78
554	±0.250	3000	240	180	130	100
604	±0.270	3300	270	220	160	120
704	±0.320	4900	-	370	-	220
804	±0.365	7100	-	510	-	295

4 Bolt Series

Size	Maximum Misalignment (degrees)	Bending Stiffness (lb-in/deg)
154	0.25	650
204	0.25	1270
254	0.25	1800
304	0.25	2730
354	0.25	4600
404	0.25	7100
454	0.25	9020
504	0.25	11800
554	0.25	16000
604	0.25	18700
704	0.25	36100
804	0.25	59000

5 Bolt Series Axial Displacement

Size	Axial Displacement Max Continuous (in) ②	Max Force (lb)	Floating Weights (lb) 18" Shaft Separation			
			RM	RZ	MS	MP
355	±0.080	1080	87	62	41	37
405	±0.090	1375	110	86	54	54
455	±0.100	1930	136	114	84	65
505	±0.110	1900	170	150	100	82
555	±0.120	2400	250	200	140	110
605	±0.130	2800	290	240	160	130
655	±0.140	3100	N/A	N/A	N/A	178
705	±0.155	4200	-	400	-	230
755	±0.165	5850	N/A	N/A	N/A	246
805	±0.180	5100	-	-	-	329
905	±0.260	11000	-	-	-	416

5 Bolt Series

Size	Maximum Misalignment (degrees)	Bending Stiffness (lb-in/deg)
355	0.20	8080
405	0.20	11530
455	0.20	15720
505	0.20	20800
555	0.20	27500
605	0.20	32900
655	0.20	54700
705	0.20	59000
755	0.20	80900
805	0.20	89500
905	0.20	121000

6 Bolt Series Axial Displacement

Size	Axial Displacement Max Continuous (in) ②	Max Force (lb)	Floating Weights (lb) 18" Shaft Separation			
			RM	RZ	MS	MP
1006	0.120	93500	N/A	N/A	N/A	570
1106	0.100	95000	N/A	N/A	N/A	800

6 Bolt Series

Size	Maximum Misalignment (degrees)	Bending Stiffness (lb-in/deg)
1006	0.16	532700
1106	0.16	663930

① For transient conditions 133% Axial Deflection is allowed for 3 and 4 bolt designs

② For transient conditions 150% Axial Deflection is allowed for 5 bolt designs

AXIAL DATA

3 Bolt Series Axial Displacement

Size	Axial Displacement Max Continuous (mm) ①	Max Force (N)	Floating Weights (kg) 457mm Shaft Separation			
			RM	RZ	MS	MP
103	±2.0	534	3.95	4.04	2.49	2.27
153	±3.9	1201	5.90	5.90	4.54	4.54
203	±3.6	1601	9.07	8.62	5.90	5.44
253	±4.3	1913	13.6	12.2	8.62	7.71
303	±5.1	2713	19.5	18.1	12.7	11.3
353	±5.8	3870	28.6	26.8	18.6	16.3
403	±6.6	4891	40.8	37.2	26.3	23.1
453	±7.2	5782	54.4	49.9	32.2	28.1

ANGULAR DATA

3 Bolt Series

Size	Maximum Misalignment (degrees)	Bending Stiffness (Nm/deg)
103	0.33	16.9
153	0.33	38.4
203	0.33	74.6
253	0.33	105
303	0.33	159
353	0.33	270
403	0.33	417
453	0.33	530

4 Bolt Series Axial Displacement

Size	Axial Displacement Max Continuous (mm) ①	Max Force (N)	Floating Weights (kg) 457mm Shaft Separation			
			RM	RZ	MS	MP
154	±2.0	1779	6.80	6.35	4.99	4.45
204	±2.5	2535	10.4	8.62	5.90	5.44
254	±3.0	2847	14.5	12.2	9.07	7.71
304	±5.6	4003	21.8	18.6	13.6	11.3
354	±4.1	5782	33.1	27.2	20.0	16.8
404	±4.6	7562	45.4	38.1	28.1	24.0
454	±5.1	8451	63.5	49.9	34.9	29.0
504	±5.8	11120	72.6	59.0	43.5	35.4
554	±6.4	13344	109	81.6	59.0	45.4
604	±6.9	14678	122	99.8	72.6	54.4
704	±8.1	21792	-	168	-	99.8
804	±9.3	31581	-	231	-	133

4 Bolt Series

Size	Maximum Misalignment (degrees)	Bending Stiffness (Nm/deg)
154	0.25	73.4
204	0.25	143
254	0.25	203
304	0.25	308
354	0.25	520
404	0.25	802
454	0.25	1020
504	0.25	1330
554	0.25	1810
604	0.25	2110
704	0.25	4080
804	0.25	6670

5 Bolt Series Axial Displacement

Size	Axial Displacement Max Continuous (mm) ②	Max Force (N)	Floating Weights (kg) 457mm Shaft Separation			
			RM	RZ	MS	MP
355	±2.03	4804	39	28	19	17
405	±2.29	6116	50	39	24	24
455	±2.54	8585	62	52	38	29
505	±2.80	8451	77.1	68.0	45.4	37.2
555	±3.10	10675	113	90.7	63.5	49.9
605	±3.30	12454	132	109	72.6	59.0
655	±3.56	13789	N/A	N/A	N/A	81
705	±3.90	18682	-	181	-	104
755	±4.19	26021	N/A	N/A	N/A	112
805	±4.60	22685	-	-	-	149
905	±6.60	48928	-	-	-	189

5 Bolt Series

Size	Maximum Misalignment (degrees)	Bending Stiffness (Nm/deg)
355	0.2	913
405	0.2	1302
455	0.2	1776
505	0.2	2350
555	0.2	3110
605	0.2	3720
655	0.2	6180
705	0.2	6670
755	0.2	9140
805	0.2	10100
905	0.2	13700

6 Bolt Series Axial Displacement

Size	Axial Displacement Max Continuous (in) ②	Max Force (lb)	Floating Weights (lb) 457mm Shaft Separation			
			RM	RZ	MS	MP
1006	3.048	415890	N/A	N/A	N/A	259
1106	2.540	422560	N/A	N/A	N/A	363

6 Bolt Series

Size	Maximum Misalignment (degrees)	Bending Stiffness (lb-in/deg)
1006	0.16	60184
1106	0.16	75011

① For transient conditions 133% Axial Deflection is allowed for 3 and 4 bolt designs

② For transient conditions 150% Axial Deflection is allowed for 5 bolt designs

Balancing

Kop-Flex high performance disc couplings are designed with balancing in mind.

Kop-Flex disc couplings are balanced to low levels of residual unbalance and, in contrast to other types of couplings, are built to retain their balance quality.

There are no clearances between mating parts and no parts to wear (like gear teeth in gear couplings). The connections between major components have light interference fits.

Kop-Flex high performance disc couplings can be balanced to any of the API standard 671 options. A component balance permits the interchange of duplicate coupling components. The assembly can then be subsequently check balanced without balance corrections. A final balance correction can be made on the assembly after the assembly check. However, this prohibits the later interchange of coupling components. If specified, residual unbalance or balance repeatability tests can be performed in accordance with API 671.

Balancing is done on precision hard-bearing balance machines. A minimal amount of ancillary tooling is used in order to reduce the associated clearance and runout errors.

Major components are match-marked to assure proper reassembly of balanced couplings.

Bolts and nuts are individually weigh balanced, which allows the interchanging of any bolt or any nut.

Field balance holes can also be provided at the request of the customer.

Windage

When couplings rotate at high speeds in enclosures, the resulting air movement generates heat and pressure differentials. This "windage" should be considered in the design of couplings and enclosures, especially when replacing a gear coupling with a dry one.

Kop-Flex has authored a paper, "Design of Coupling Enclosures," which is available along with a computer disc containing a program for predicting coupling and guard temperatures. Contact Kop-Flex for this "windage" package or for enclosure design recommendations.

Installation

Factory assembled, disc pack units greatly simplify the installation of Kop-Flex high performance disc couplings.

For reduced moment style couplings, installation consists of mounting the preassembled hub/sleeve/disc pack assemblies onto the equipment shafts. The spacer is then bolted to the sleeve flanges.

For marine style couplings, rigid hubs are mounted on the equipment shafts, then a factory assembled center section is bolted to the rigid hub flanges.

Installation instructions and a general arrangement drawing are supplied with each coupling.

Shimming

Two identical steel shim packs are provided with each Kop-Flex high performance disc coupling. These packs consist of individual shims of various thicknesses.

The coupling is designed to use one full shim pack if the actual installation shaft or flange separation matches the design start-up separation. This allows for a total spacing adjustment of plus or minus the thickness of one pack.

Shipping Screws

Shipping screws lock and stabilize the flexing subassembly during machining, balancing and shipping. They also provide built-in tooling to collapse the disc packs during the installation procedure.

Prestretch

Prestretch is the axial stretch of the disc packs established at coupling installation to accommodate changes in shaft separation, such as thermal growth.

Prestretching of the packs ensures that they will run in the neutral position at normal operating conditions. Thus, axial misalignment related stresses will be minimized.

Solo Plates

Two types of solo plates are available. These are a moment simulator plate and a solo adapter plate.

A moment simulator plate simulates the connected coupling bending moment on the shaft when required for testing.

A solo adapter plate is used to lock together a coupling subassembly for uncoupled equipment operation, and is an option in API 671. Consult Kop-Flex if a coupling needs to be soloed without a plate; shipping screws alone can be used to rigidize the coupling subassemblies, but certain conditions must be met.

KS disc couplings are designed to meet API 671 and provide a less expensive alternative when application speeds are in the intermediate range!

Typical Applications

- Motor to gearbox
- Turbine to gearbox/compressor
- Auxiliary drives
- Turbine to gen. sets

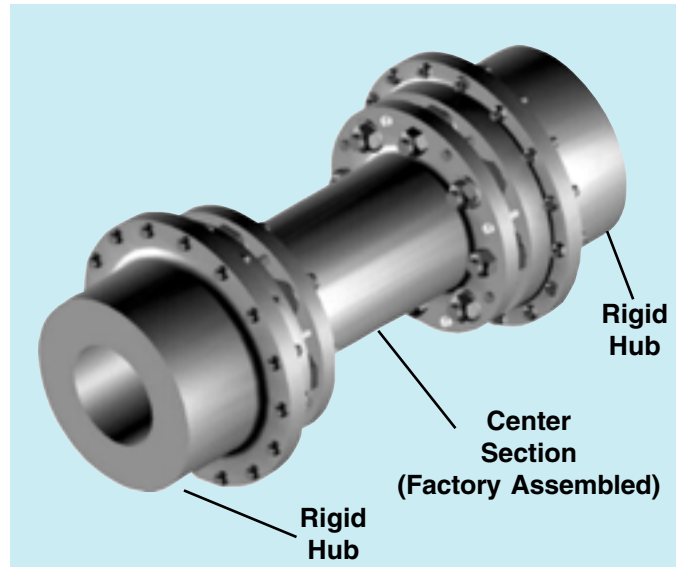

Features

- Machined and balanced to meet API 671
- Rigid hubs allow for large bore capacity
- Stainless steel flex discs-same as Kop-Flex discs
- Less expensive alternative

Application Factors

Generally constant torque with off-design conditions (Turbines, centrifugal compressors, gearboxes)	1.50
API 671 - 3rd Edition	1.50
Moderate torque fluctuations (Large fans, screw compressors, etc.)	2.00

Factory Assembled Center Section

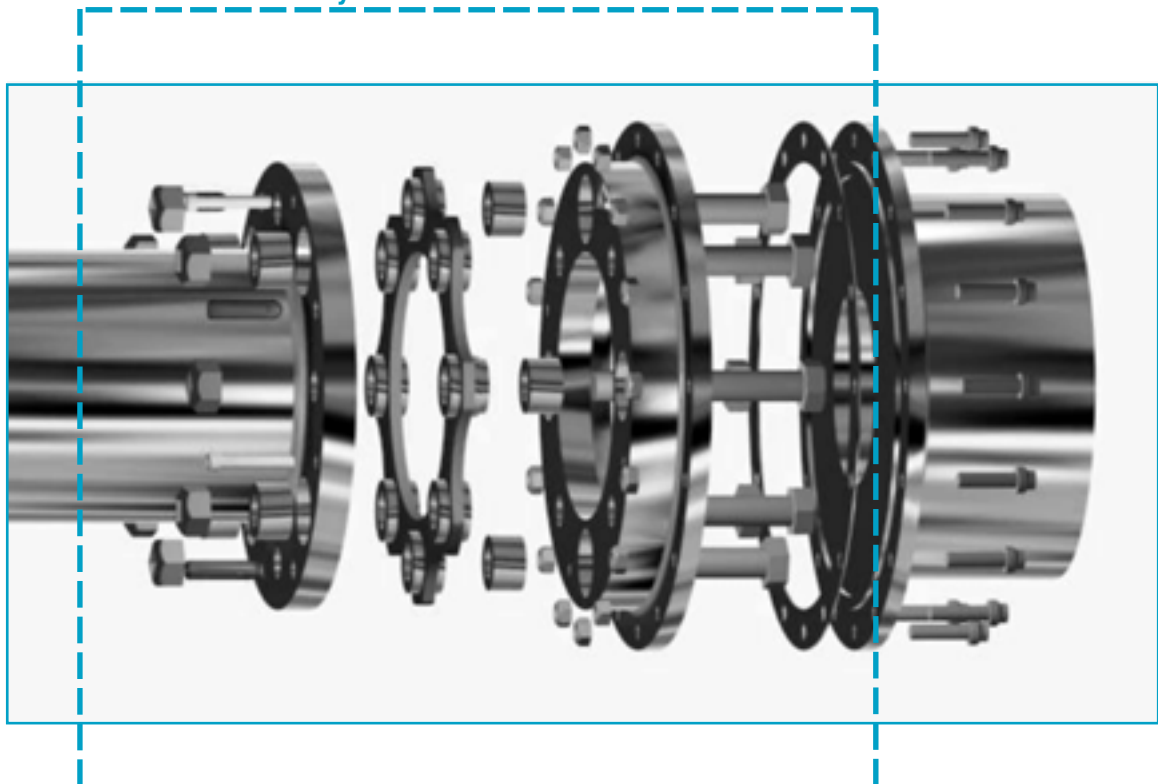

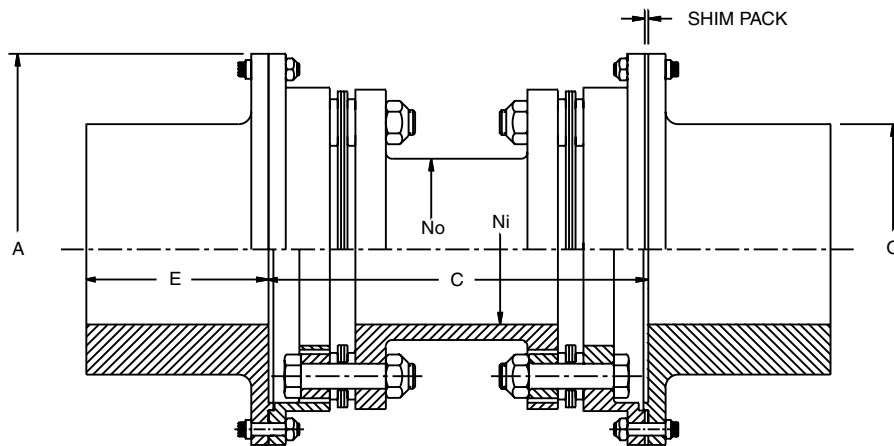

Conversion Factors (U.S. Customary to Metric)

1 lb (mass)	=	0.4536 kg
1 inch	=	25.4 mm
1 in-lb	=	0.113 Nm
1 HP	=	0.7457 kW
1 lb-in ²	=	0.000293 kg-m ²

Selection Data

Size	Max. ¹ Continuous Rating HP/100 RPM	Max. ¹ Torque Rating		Maximum Speed RPM	Max. Bore (in)	Total ² Weight (lbs)	Total ² WR ² (lb-in ²)	Total Stiffness (lb-in/radx10 ⁶)	Spacer Tube/in			Size
		Continuous (in-lb)	Peak (in-lb)						K (lb-in/radx10 ⁶)	Weight (lbs)	WR ² (lb-in)	
103	9.5	6000	8000	14200	2.88	22.0	61	0.3	11.2	.24	.27	103
153	32.4	20400	27200	12500	3.88	41.4	187	1.1	33.4	.40	.80	153
204	85.7	54000	72000	11100	4.63	69.1	420	2.8	111	.80	2.66	204
254	124	78000	104000	9900	5.50	99.8	893	4.2	180	.78	4.30	254
304	212	133500	178000	8700	6.50	152	1770	8.0	336	1.17	8.06	304
354	357	225000	300000	7500	7.50	240	3730	14	709	1.96	17.0	354
404	512	322500	430000	6600	9.00	344	6830	21	1020	2.21	24.3	404
454	607	383000	510000	6000	9.75	455	11400	27	1550	2.54	37.0	454
504	857	540000	720000	5600	10.75	576	16600	38	2620	3.67	62.6	504
554	1200	758000	1010000	4800	12.00	792	28400	50	3120	3.89	74.7	554
604	1570	990000	1320000	4600	13.00	992	40700	69	4800	5.21	115	604
705	3590	2265000	3020000	3860	15.75	1690	102000	160	12700	9.43	304	705
805	5500	3465000	4620000	3450	18.00	2440	185000	240	21200	12.6	507	805
905	6190	3900000	5200000	3100	20.00	3180	304000	300	27500	11.7	658	905

Dimensions and Misalignment Capacities

Size	A (in)	No (in)	Ni (in)	Typical Bore (in)	Typical E (in)	Typical O (in)	Min. C (in)	Misalignment Capacities		Size
								Axial (in)	Angular (degrees)	
103	5.44	2.25	2.00	2.0	1.94	3.81	4.63	± .080	0.20	103
153	6.81	3.00	2.69	2.5	2.38	4.81	5.75	± .115	0.25	153
204	7.81	3.88	3.38	3.0	3.00	5.75	6.38	± .100	0.20	204
254	9.31	4.88	4.50	3.5	3.56	6.75	6.50	± .120	0.20	254
304	10.62	5.50	5.00	4.0	4.12	7.75	7.75	± .140	0.20	304
354	12.28	6.25	5.50	4.5	4.62	9.00	9.25	± .160	0.20	354
404	13.94	7.00	6.25	5.0	5.25	10.12	10.88	± .180	0.20	404
454	15.56	8.00	7.25	5.5	5.88	11.38	11.25	± .200	0.20	454
504	16.69	8.75	7.75	6.0	6.38	12.25	12.25	± .230	0.20	504
554	18.69	9.25	8.25	6.5	7.00	13.62	13.75	± .250	0.20	554
604	20.00	10.00	8.75	7.0	7.62	14.62	14.63	± .270	0.20	604
705	24.00	12.25	10.38	8.5	9.00	17.50	17.88	± .230	0.15	705
805	26.88	13.75	11.50	9.5	10.00	19.50	20.13	± .260	0.15	805
905	30.00	16.00	14.25	11.0	11.50	22.00	21.38	± .340	0.15	905

① To account for off-design fluctuating or continuous torques, an experience or application factor should be used. API 671 and Kop-Flex recommends 1.5 minimum for general turbomachinery applications.

② Mass elastic data based on couplings with typical bores and 18.00" shaft separation up to #705, and min. C for #805 and #905; design and data can be changed to meet specific requirements.

All major components are made of carbon steel.

KS Series with HT Disc Packs Metric

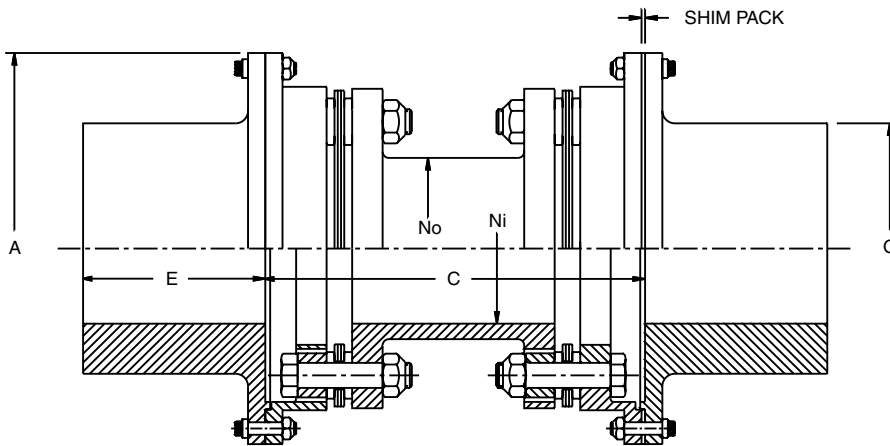

Conversion Factors (U.S. Customary to Metric)

1 lb (mass)	=	0.4536 kg
1 inch	=	25.4 mm
1 in-lb	=	0.113 Nm
1 HP	=	0.7457 kW
1 lb-in ²	=	0.000293 kg-m ²

Selection Data (S1 Units)

Size	Max. \odot Continuous Rating (kW/RPM)	Max. \odot Torque Rating		Maximum Speed (RPM)	Max. Bore (mm)	Total \odot Weight (kgs)	Total \odot WR ² (kgm ²)	Total Stiffness (MNm/rad)	Spacer Tube			Size
		Continuous (kNm)	Peak						K (MNm/rad)/m	Weight (kg)/m	WR ² (kgm ²)/m	
103	.07	.68	.90	14200	73	9.98	.018	.03	.03	4.29	.003	103
153	.24	2.30	3.07	12500	99	18.8	.055	.12	.10	7.14	.009	153
204	.34	6.10	8.14	11100	118	31.3	.123	.32	.32	14.3	.031	204
254	.92	8.81	11.8	9900	140	45.3	.262	.47	.52	13.9	.050	254
304	1.6	15.1	20.1	8700	165	68.9	.519	.90	.96	20.9	.093	304
354	2.7	25.4	33.9	7500	191	109	1.09	1.6	2.0	35.0	.196	354
404	3.8	36.4	48.6	6600	229	156	2.00	2.4	2.9	39.5	.280	404
454	4.5	43.3	57.6	6000	248	206	3.34	3.1	4.4	45.4	.427	454
504	6.4	61.0	81.4	5600	273	261	4.86	4.3	7.5	65.5	.722	504
554	8.9	85.7	114	4800	305	359	8.32	5.6	9.0	49.5	.862	554
604	12	112	149	4600	330	450	11.9	7.8	14	93.0	1.33	604
705	27	256	341	3860	400	767	29.9	18	36	168	3.51	705
805	41	392	522	3450	457	1110	54.2	27	61	225	5.85	805
905	46	441	588	3100	508	1440	89.1	34	79	209	7.59	905

Dimensions and Misalignment Capacities

Size	A (mm)	No (mm)	Ni (mm)	Typical Bore (mm)	Typical E (mm)	Typical O (mm)	Min. C (mm)	Misalignment Capacities		Size
								Axial (mm)	Angular (degrees)	
103	138	57	51	51	49	97	118	±2.0	0.20	103
153	173	76	68	64	60	122	146	±2.9	0.25	153
204	198	99	86	76	76	146	162	±2.5	0.20	204
254	236	124	114	89	90	171	165	±3.1	0.20	254
304	270	140	124	102	105	197	197	±3.6	0.20	304
354	312	159	140	114	117	229	235	±4.1	0.20	354
404	354	178	159	127	133	257	276	±4.6	0.20	404
454	395	203	184	140	149	289	286	±5.1	0.20	454
504	424	222	197	152	162	311	311	±5.8	0.20	504
554	475	235	210	165	178	346	349	±6.4	0.20	554
604	508	254	222	178	194	371	372	±6.9	0.20	604
705	610	311	264	216	229	445	454	±5.8	0.15	705
805	683	349	292	241	254	495	511	±6.6	0.15	805
905	762	406	362	279	292	559	543	±8.6	0.15	905

① To account for off-design fluctuating or continuous torques, an experience or application factor should be used. API 671 and Kop-Flex recommends 1.5 minimum for general turbomachinery applications.

② Mass elastic data based on couplings with typical bores and 18.00" shaft separation up to #705, and min. C for #805 and #905; design and data can be changed to meet specific requirements.

All major components are made of carbon steel.

Flexible Diaphragm Couplings

The Next Generation in High Performance Coupling Design



Size #8.5 MSM ("J" Type Frame 7 Load Coupling)—operates in excess of 250,000 HP (186 MW) at 3600 rpm. (Shown next to size #1.5 RMM.)

Customized diaphragms for special applications using Finite Element Analysis (FEA).

- No welds
- No splines
- Patented replaceable flex elements

Basic Theory of Operation

Our diaphragm couplings transmit torque from the driving shaft via a rigid hub, then through a flexible diaphragm to a spacer. While transmitting torque to the spacer, the diaphragm deforms to accommodate misalignment. The spacer, in turn, drives matching components attached to the driven equipment.

Kop-Flex Revolutionized Diaphragm Design

Kop-Flex has manufactured extremely reliable, maintenance-free diaphragm couplings since the mid-1970's, with well over ten million hours of operation. Our early experience making diaphragm couplings led us to reexamine prevailing diaphragm design. In 1989, we developed and patented a unique refinement technique eliminating the need for welds and allowed for field replaceable flex elements. In addition, we began to take full advantage of our FEA and computer aided, manufacturing techniques. The result? Kop-Flex High Performance diaphragm couplings combine the positives of competing diaphragm couplings with additional design features. It is also easier to replace a competing diaphragm coupling with a superior Kop-Flex coupling.

How Kop-Flex Improves the Best Features of Diaphragm Couplings

Field replaceable, stockable diaphragms

Advantages

- Fast, easy repair
- Extremely reliable

The Kop-Flex diaphragm is bolted (not welded) to the spacer. You can remove our diaphragm without moving the equipment or removing the rigid hub. This reduces downtime and expense. It is much easier to stock or reorder a replaceable Kop-Flex diaphragm than a big welded assembly. And since field failures sometimes occur in welds, our newer, no-weld design is extremely reliable.

Specially contoured, one-piece diaphragm

Advantages

- Simple, less hardware
- Cost competitive
- Easy to customize
- Quick delivery

Like any diaphragm coupling, our ability to transmit torque and handle misalignment depends chiefly on the thickness distribution (or profile) of the diaphragm. Unlike competing designs, we use a single stainless steel diaphragm. This eliminates the need for extra bolts, rivets, splines and filler rings. It also greatly simplifies the task of shaping the perfect diaphragm, since we need only one diaphragm per end. We use a modified profile based on extensive FEA. The thickness of the diaphragm varies so stress is distributed evenly when the diaphragm flexes under the simultaneous effects of torque, speed, axial misalignment and angular misalignment. Also, unlike competitors, Kop-Flex translates CAD and CAM into quick deliveries. These techniques stand behind our ability to customize diaphragms for special applications.

Patented, donut shaped diaphragm

Advantages

- Handles more misalignment
- Greater range of torsional stiffness

The unique Kop-Flex diaphragm profile follows the modified power function toward the center. Unlike any competing designs, the diaphragm doubles back before it's attached to the spacer. Rather than a flat or wavy disc, the Kop-Flex brand diaphragm is more like a donut shape and is one piece of stainless steel. In effect, we have more diaphragm in a given space. This allows the Kop-Flex diaphragm to handle more torque, axial misalignment, or angular misalignment than competing designs of comparable size.

Other Features

- Piloted fits
- Diaphragms are 15-5/17-4 PH shot-peened, stainless steel
- Inherently low windage design conforms to API 671

Options

- Electrically insulated
- Shear section type
- Torsionally damped hybrids
- Torque measurement
- Fail-safe, back-up gears
- Alternate spacer materials
- Customized profiles for special applications

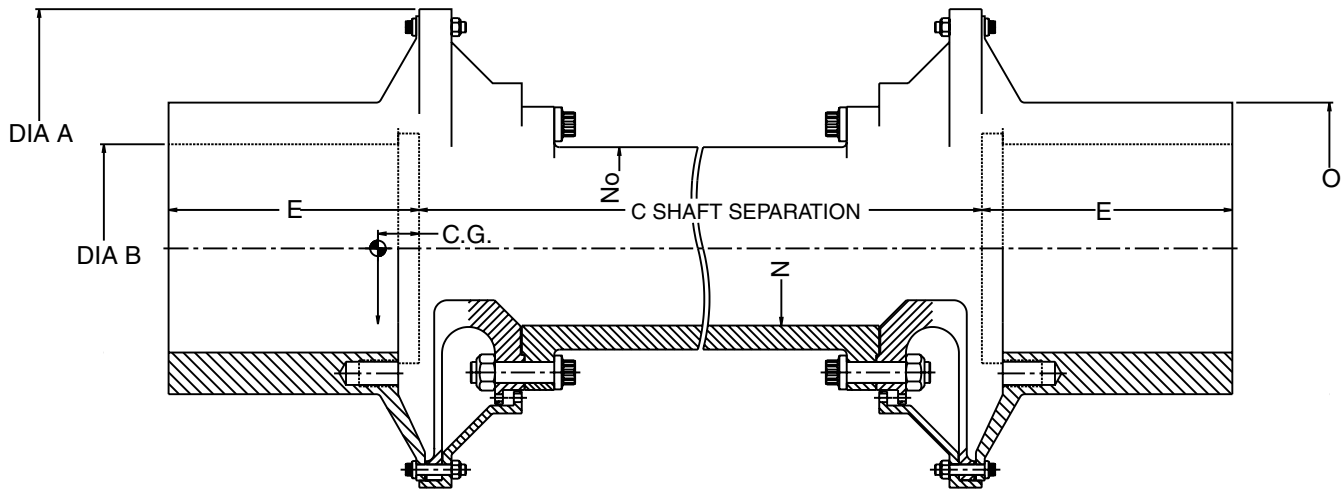

MS Style Selection and Dimensional Data (Imperial Units)

Size	Series	① ② Max. Continuous Torque Rating (in-lb)	③ Axial Rating per Cplg. (± in)	④ Misalignment Rating per End (± deg)	Maximum Speed (RPM)	Total Weight (lbs)	Total WR ² (lb-in ²)	Half Coupling C.G. (in)	Total Stiffness K (lb-in/rad x 10 ³)	Spacer Tube/in			Coupling OD A (in)	⑤ Bore (max.) B (in)	⑥ Shaft-to- Shaft (min.) C (in)	No. (in)	Ni (in)	E Standard (in)	Max. OD O (in)
										K (lb-in/rad x 10 ³)	Weight (lbs)	WR ² (lb-in ²)							
1.0	MSM	19000	0.063	0.33	24000	22.2	80	0.53	0.4	9.2	0.18	0.20	6.00	3.25	4.68	2.33	2.15	3.03	4.50
1.0	MSH	25000	0.050	0.25	24000	23.3	80	0.49	0.5	11.7	0.24	0.30							
1.0	MSX	36000	0.035	0.20	24000	25.7	80	0.41	0.7	17.0	0.36	0.40							
1.5	MSM	38000	0.075	0.33	20000	35.4	160	0.72	0.9	21.1	0.31	0.50	7.00	4.00	5.69	2.72	2.45	3.59	5.25
1.5	MSH	50000	0.060	0.25	20000	37.4	170	0.67	1.1	27.4	0.42	0.70							
1.5	MSX	72000	0.040	0.20	20000	41.5	170	0.58	1.4	39.0	0.65	1.00							
2.0	MSM	89000	0.106	0.33	17000	64	480	0.70	2.4	64.6	0.55	1.60	9.16	5.38	6.75	3.59	3.09	4.19	7.25
2.0	MSH	118000	0.085	0.25	17000	67	490	0.64	3.0	84.6	0.74	2.10							
2.0	MSX	170000	0.060	0.20	17000	75	510	0.53	3.8	121	1.16	3.00							
2.5	MSM	169000	0.125	0.33	14000	99	1000	0.79	5.1	149	0.82	3.70	10.95	6.75	8.31	4.43	3.99	4.75	9.00
2.5	MSH	225000	0.100	0.25	14000	104	1000	0.72	6.2	199	1.15	4.90							
2.5	MSX	325000	0.070	0.20	14000	117	1100	0.60	7.7	286	1.81	7.00							
3.0	MSM	308000	0.156	0.33	13000	166	2500	1.26	10.4	328	1.27	8.10	13.09	8.25	9.00	5.31	4.74	6.03	11.00
3.0	MSH	410000	0.125	0.25	13000	175	2500	1.16	12.6	435	1.77	10.70							
3.0	MSX	590000	0.085	0.20	13000	194	2600	1.00	16	623	2.80	15.30							
3.5	MSM	450000	0.175	0.33	12000	226	4500	1.31	17	595	1.44	14.60	14.88	9.50	9.69	6.62	5.91	6.56	12.25
3.5	MSH	600000	0.140	0.25	12000	239	4600	1.23	20	791	1.98	19.50							
3.5	MSX	860000	0.095	0.20	12000	258	4800	1.09	24	1135	3.02	27.90							
4.0	MSM	690000	0.206	0.33	11000	465	12500	2.43	29	968	2.13	23.80	16.97	11.00	14.31	7.03	6.31	9.00	14.25
4.0	MSH	920000	0.165	0.25	11000	480	12600	2.33	34	1285	2.96	31.60							
4.0	MSX	1320000	0.110	0.20	11000	510	13000	2.16	42	1846	4.67	45.40							
4.5	MSM	1010000	0.231	0.33	10000	581	18600	2.66	43	1628	2.72	40.10	18.97	12.50	15.00	8.06	6.93	9.81	16.25
4.5	MSH	1350000	0.185	0.25	10000	602	19000	2.55	52	2161	3.76	53.20							
4.5	MSX	1930000	0.125	0.20	10000	639	19500	2.36	62	3086	5.87	75.90							
5.0	MSM	1410000	0.263	0.33	9000	825	35300	2.86	64	2552	3.37	62.80	21.16	14.00	14.75	9.06	7.01	10.88	18.25
5.0	MSH	1880000	0.210	0.25	9000	852	35900	2.74	76	3385	4.65	83.30							
5.0	MSX	2710000	0.140	0.20	9000	900	36800	2.55	91	4881	7.32	120.10							
5.5	MSM	1790000	0.281	0.33	8000	1097	53800	3.25	82	3366	4.01	85.00	22.91	15.00	18.94	9.69	8.71	12.00	19.75
5.5	MSH	2380000	0.225	0.25	8000	1129	54600	3.14	97	4596	5.56	113.10							
5.5	MSX	3420000	0.155	0.20	8000	1186	55800	2.94	115	6587	8.73	162.10							

Consult Kop-Flex engineering department for mass elastic data.

Consult Kop-Flex for custom or special designs.

- ① Peak torque rating is 133% of maximum continuous torque rating. Peak torques are defined as intermittent conditions which may occur at multiple intervals (such as break-away start up torques).
 - ② Maximum momentary torque rating is 176% of maximum continuous torque rating. Maximum momentary torques are defined as torsional impact type loads which may occur for one brief duration (such as generator short circuits).
 - ③ Axial and angular capabilities shown are for the "I" type diaphragm. Additional axial and angular capacities can be accommodated with the "J" type or the "U" type diaphragms. See page 57 for details.
 - ④ Maximum bore capacity shown are for straight shaft. Consult Kop-Flex for maximum bore capacity of tapered and keyed shafts.
 - ⑤ Minimum standard shaft separation is shown. Consult Kop-Flex for shorter shaft separations.
- Specifications and selection data are subject to change without notice.

* Consult Kop-Flex for larger sizes and custom-designs.

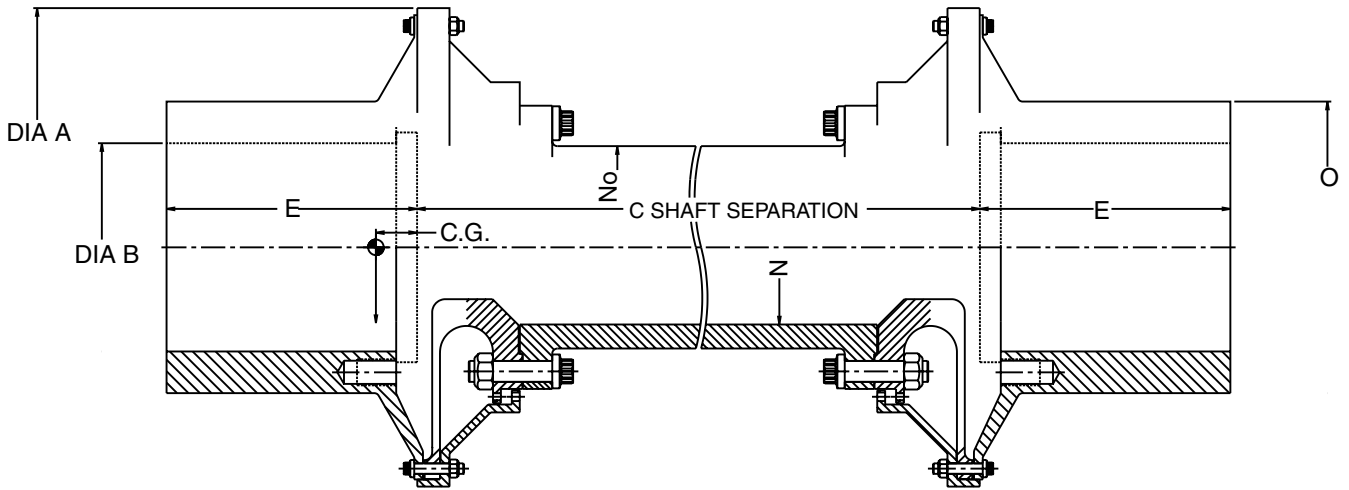

MS Style Selection and Dimensional Data (SI Units)

Size	Series	⊙ Max. Continuous Torque Rating (kN-m)	⊙ Axial Rating per Cplg. (± mm)	⊙ Misalignment Rating per End (± deg)	Nominal Bore Capacity (mm)	Maximum Speed (RPM)	Total Weight (kg)	Total WR ² (kg-m ²)	Half Coupling C.G. (in)	Total Stiffness K (n-m/rad x 10 ⁶)	Spacer Tube/in			Coupling OD A (mm)	⊙ Bore (max.) B (mm)	⊙ Shaft-to-Shaft (min.) C (mm)	No. (mm)	Ni (mm)	E Standard (mm)	Max. OD O (mm)
											K (n-m/rad x 10 ⁶)	Weight (kg)	WR ² (kg-m ²)							
1.0	MSM	2.15	1.6	0.33	64	24000	10.1	.023	13	.05	.03	3.21	.002	152	83	119	59	55	77	114
1.0	MSH	2.82	1.3	0.25	64	24000	10.6	.023	12	.06	.03	4.29	.003							
1.0	MSX	4.07	0.9	0.20	64	24000	11.7	.023	10	.08	.05	6.43	.005							
1.5	MSM	4.29	1.9	0.33	76	20000	16.1	.047	18	.10	.06	5.54	.006	178	102	145	69	62	91	133
1.5	MSH	5.65	1.5	0.25	76	20000	17.0	.050	17	.12	.08	7.50	.008							
1.5	MSX	8.13	1.0	0.20	76	20000	18.8	.050	15	.16	.11	11.6	.012							
2.0	MSM	10.1	2.7	0.33	89	17000	29.0	.140	18	.27	.19	9.82	.018	233	137	171	91	82	106	184
2.0	MSH	13.3	2.2	0.25	89	17000	30.4	.143	16	.34	.24	13.2	.024							
2.0	MSX	19.2	1.5	0.20	89	17000	34.0	.149	13	.43	.35	20.7	.035							
2.5	MSM	19.1	3.2	0.33	102	14000	44.9	.293	20	.58	.43	14.6	.043	278	171	211	113	101	121	229
2.5	MSH	25.4	2.5	0.25	102	14000	47.2	.293	18	.70	.57	20.5	.056							
2.5	MSX	36.7	1.8	0.20	102	14000	53.1	.322	15	.87	.82	32.3	.081							
3.0	MSM	34.8	4.0	0.33	127	13000	75.3	.732	32	1.17	.94	22.7	.093	332	210	229	135	120	153	279
3.0	MSH	46.3	3.2	0.25	127	13000	79.4	.732	29	1.42	1.25	31.6	.123							
3.0	MSX	66.7	2.2	0.20	127	13000	88.0	.761	25	1.81	1.79	50.0	.176							
3.5	MSM	50.8	4.4	0.33	140	12000	102.5	1.317	33	1.92	1.71	25.7	.168	378	241	246	168	155	167	311
3.5	MSH	67.8	3.6	0.25	140	12000	108.4	1.346	31	2.26	2.27	35.4	.225							
3.5	MSX	97.2	2.4	0.20	140	12000	117.0	1.404	28	2.71	3.26	53.9	.321							
4.0	MSM	78.0	5.2	0.33	191	11000	210.9	3.658	62	3.28	2.78	38.0	.274	431	279	363	179	160	229	362
4.0	MSH	103.9	4.2	0.25	191	11000	217.7	3.687	59	3.84	3.69	52.9	.364							
4.0	MSX	149.1	2.8	0.20	191	11000	231.3	3.804	55	4.75	5.30	83.4	.523							
4.5	MSM	114.1	5.9	0.33	203	10000	263.5	5.442	68	4.86	4.67	48.6	.462	482	318	381	205	184	249	413
4.5	MSH	152.5	4.7	0.25	203	10000	273.1	5.559	65	5.87	6.20	67.1	.613							
4.5	MSX	218.1	3.2	0.20	203	10000	289.9	5.706	60	7.00	8.85	104.8	.874							
5.0	MSM	159.3	6.7	0.33	229	9000	374.2	10.329	73	7.23	7.32	60.2	.723	537	356	375	230	208	276	464
5.0	MSH	212.4	5.3	0.25	229	9000	386.5	10.504	70	8.59	9.71	83.0	.960							
5.0	MSX	306.2	3.6	0.20	229	9000	408.2	10.768	65	10.28	14.01	130.7	1.38							
5.5	MSM	202.2	7.1	0.33	254	8000	497.6	15.742	83	9.26	9.66	71.6	.979	582	381	481	246	221	305	502
5.5	MSH	268.9	5.7	0.25	254	8000	512.1	15.976	80	10.96	13.19	99.3	1.30							
5.5	MSX	386.4	3.9	0.20	254	8000	538.0	16.327	75	12.99	18.90	155.9	1.87							

Consult Kop-Flex engineering department for mass elastic data.

Consult Kop-Flex for custom or special designs.

① Peak torque rating is 133% of maximum continuous torque rating. Peak torques are defined as intermittent conditions which may occur at multiple intervals (such as break-away start up torques).

② Maximum momentary torque rating is 176% of maximum continuous torque rating. Maximum momentary torques are defined as torsional impact type loads which may occur for one brief duration (such as generator short circuits).

③ Axial and angular capabilities shown are for the "I" type diaphragm. Additional axial and angular capacities can be accommodated with the "J" type or the "U" type diaphragms. See page 57 for details.

④ Maximum bore capacity shown are for straight shaft. Consult Kop-Flex for maximum bore capacity of tapered and keyed shafts.

⑤ Minimum standard shaft separation is shown. Consult Kop-Flex for shorter shaft separations.

Specifications and selection data are subject to change without notice.

* Consult Kop-Flex for larger sizes and custom-designs.

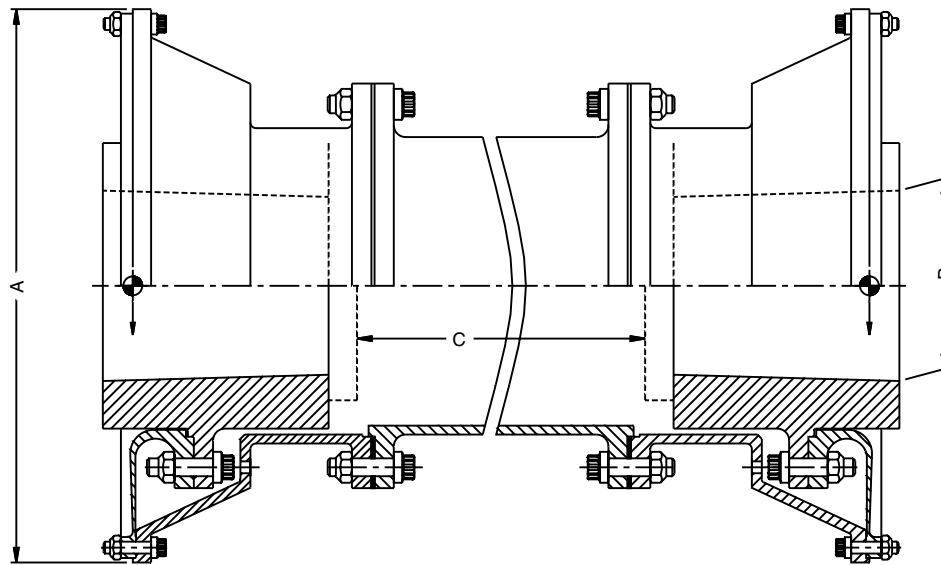

RM Style Selection and Dimensional Data (Imperial Units)

Size	⑥ Series	① ② Max. Continuous Torque Rating (in-lb)	③ Axial Rating per Cplg. (± In.)	③ Misalignment Rating per End (± Deg.)	Maximum Speed (RPM)	Coupling O.D. A (in)	④ Bore (nominal) B (in)	⑤ Shaft-to-Shaft (min.) C (in)
1.5	RMM	30000	0.050	0.25	24000	6.03	2.00	2.50
2.0	RMM	60000	0.062	0.25	19000	7.35	2.50	2.50
2.5	RMM	100000	0.075	0.25	18000	8.67	3.00	3.12
3.0	RMM	160000	0.088	0.25	15000	10.31	3.50	3.12
3.5	RMM	240000	0.100	0.25	14000	11.63	4.00	3.12
4.0	RMM	342000	0.113	0.25	13000	13.12	4.50	3.50
4.5	RMM	469000	0.125	0.25	12000	14.53	5.00	4.00
5.0	RMM	624000	0.138	0.25	11000	16.09	5.50	4.00
5.5	RMM	810000	0.150	0.25	10000	17.50	6.00	4.50
6.0	RMM	1030000	0.160	0.25	9000	18.82	6.50	4.62

Consult Kop-Flex engineering department for mass elastic data.

Consult Kop-Flex for custom or special designs.

① Peak torque rating is 133% of maximum continuous torque rating. Peak torques are defined as intermittent conditions which may occur at multiple intervals (such as break-away start up torques).

② Maximum momentary torque rating is 176% of maximum continuous torque rating. Maximum momentary torques are defined as torsional impact type loads which may occur for one brief duration (such as generator short circuits).

③ Axial and angular capabilities shown are for the standard RMM series. Consult Kop-Flex for higher axial and angular capacities.

④ Nominal bore capacities are shown. Consult Kop-Flex for higher bore capacities.

⑤ Minimum shaft separation is shown. Consult Kop-Flex for shorter shaft separations.

⑥ Integral hub configuration is offered for sizes 3.0 and below.

* Consult Kop-Flex for larger sizes and custom-designs.

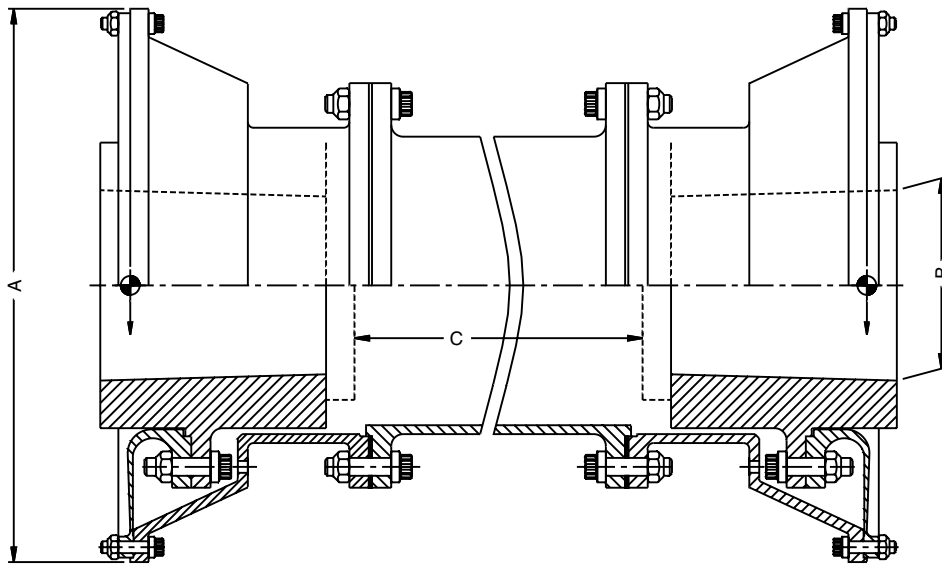

RM Style Selection and Dimensional Data (SI Units)

Size	⑥ Series	① ② Max. Continuous Torque Rating (kNm)	③ Axial Rating per Cplg. (± mm.)	③ Misalignment Rating per End (± Deg.)	Maximum Speed (RPM)	Coupling O.D. A (mm)	④ Bore (nominal) B (mm)	⑤ Shaft-to-Shaft (min.) C (mm)
1.5	RMM	3.39	1.3	0.25	24000	153	51	64
2	RMM	6.78	1.6	0.25	19000	187	64	64
2.5	RMM	11.3	1.9	0.25	18000	220	76	79
3	RMM	18.1	2.2	0.25	15000	262	89	79
3.5	RMM	27.1	2.5	0.25	14000	295	102	79
4	RMM	38.6	2.9	0.25	13000	333	114	89
4.5	RMM	53.0	3.2	0.25	12000	369	127	102
5	RMM	70.5	3.5	0.25	11000	409	140	102
5.5	RMM	91.5	3.8	0.25	10000	445	152	114
6	RMM	116	4.1	0.25	9000	478	165	117

Consult Kop-Flex engineering department for mass elastic data.

Consult Kop-Flex for custom or special designs.

- ① Peak torque rating is 133% of maximum continuous torque rating. Peak torques are defined as intermittent conditions which may occur at multiple intervals (such as break-away start up torques).
- ② Maximum momentary torque rating is 176% of maximum continuous torque rating. Maximum momentary torques are defined as torsional impact type loads which may occur for one brief duration (such as generator short circuits).
- ③ Axial and angular capabilities shown are for the standard RMM series. Consult Kop-Flex for higher axial and angular capacities.
- ④ Nominal bore capacities are shown. Consult Kop-Flex for higher bore capacities.
- ⑤ Minimum shaft separation is shown. Consult Kop-Flex for shorter shaft separations.
- ⑥ Integral hub configuration is offered for sizes 3.0 and below.

* Consult Kop-Flex for larger sizes and custom-designs.

Step 1.

Calculate the normal, continuous torque with specified application service factor. Select the coupling which has a maximum continuous torque rating (shown on pages 52 through 55) greater than the normal continuous torque with specified application service factor.

Application Factors

Generally constant torque with off-design conditions (Turbines, centrifugal compressors, gearboxes) API 671 - 3rd Edition	1.50
Moderate torque fluctuations (Large fans, screw compressors, etc.)	2.00

Step 2.

Check the maximum momentary torque capacity of the coupling selected. (Consult Kop-Flex for synchronous motor applications.)

Step 3.

Check the maximum bore capacity where applicable or contact Kop-Flex for customized flange bolt patterns.

Step 4.

Check the axial and angular misalignment requirements of the application (thermal growth, etc....)

Step 5.

Check that the coupling will not interfere with the machinery housings, guards, piping, or the equipment housing and that it will fit in the shaft separation required.

Coupling selection, Mass elastic data, windage data, lateral critical speeds and axial natural frequencies (ANFs) can be supplied by Kop-Flex as required.

Example:

Application: Gas turbine driving centrifugal compressor
 38,500 HP (28,700 kW) at 4600 rpm
 Turbine shaft = 5 in. (127 mm) - tapered, keyless hydraulic
 Compressor shaft = 5 in. (127 mm) - tapered keyless hydraulic
 AP1671 service factor required (1.50)
 Angular misalignment capacity required = 0.25°
 Compressor is sensitive to overhung weight

Calculation:

$$\begin{aligned} \text{Normal, continuous torque} &= \frac{\text{HP} \times 63025 \times \text{S.F.}}{\text{RPM}} \\ &= \frac{38,500 \times 63025 \times 1.50}{4600} \\ &= 791,238 \text{ in.-lb (102926 N-m)} \end{aligned}$$

Selection:

Size #4.0 MSH/RMH/#5.5 RMM
 Marine style (MS) coupling on turbine end and reduced moment (RM style on the compressor end).
 Check steps 2 through 5 as stated above.

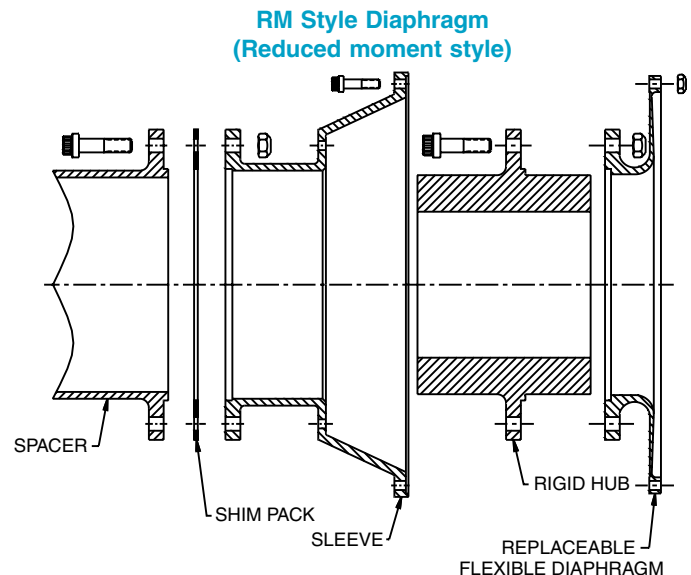
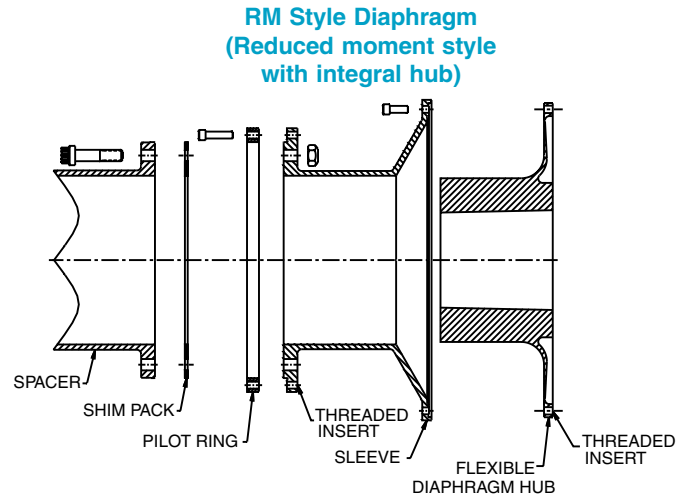
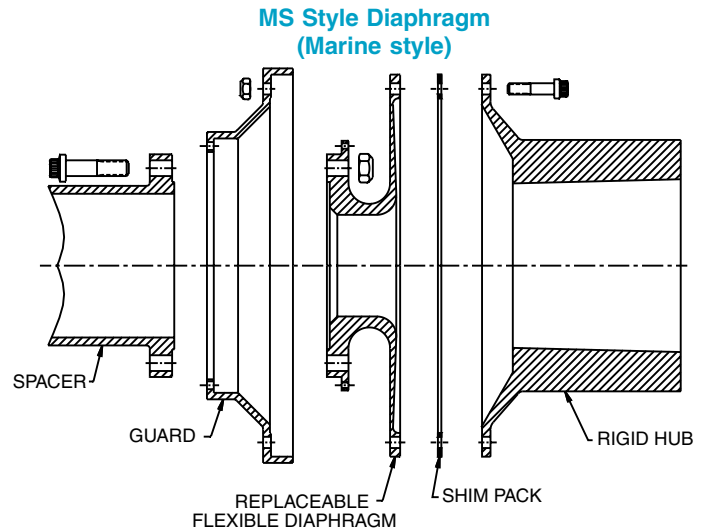

Standard

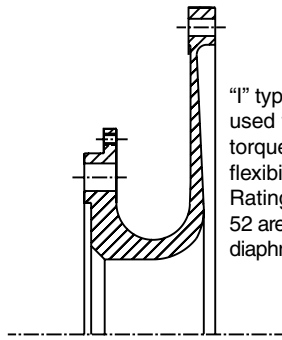

“I” Type Diaphragm

“I” type diaphragms are used for moderate torque and/or moderate flexibility requirements. Ratings shown on page 52 are for the “I” type diaphragms.

Optional

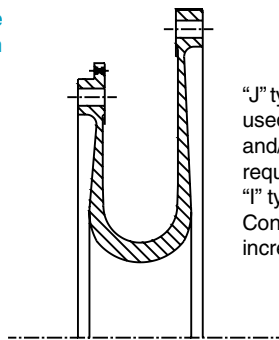

“J” Type Diaphragm

“J” type diaphragms are used for higher torque and/or higher flexibility requirements than the “I” type diaphragm. Consult Kop-Flex for increased capacities.

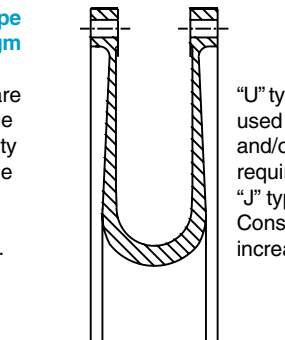

“U” Type Diaphragm

“U” type diaphragms are used for higher torque and/or higher flexibility requirements than the “J” type diaphragm. Consult Kop-Flex for increased capacities.

Retrofit Applications

Replacing any high speed coupling with another type of high speed coupling requires great care. The replacement coupling should have the same characteristics as the original equipment. When supplying a coupling for a retrofit application, Kop-Flex tries to match the weight, overhung moment and torsional stiffness of the existing coupling. It is important to supply this information when you request a quote. The dimensional constraints, the history of the existing coupling and the reasons you are changing the coupling are also required. If the original coupling can not be replaced with one of comparable mass-elastic characteristics, Kop-Flex recommends a thorough torsional and lateral vibration study of the system.

“Drop-In” Replacement for a Goodrich*

The heart of a Kop-Flex flexible diaphragm coupling (the flex elements and spacer) can be bolted directly to the rigid hubs used by Goodrich* (Bendix*) diaphragm couplings. You can drop a superior Kop-Flex diaphragm coupling into any application covered by a Goodrich* without removing the rigid hubs from the shafts. The following interchange guide will help you select the right Kop-Flex replacement for a Goodrich* coupling. The chart covers Goodrich* models 74E and 88E. To interchange with Goodrich* models 67E and 81E, ask Kop-Flex about coupling retrofit considerations.

Goodrich* Interchange Guide

Goodrich* Diaphragm	Kop-Flex Interchange	Goodrich* Diaphragm	Kop-Flex Interchange
88E305 or 74E305	1.0 MSM	88E314 or 74E314	3.5 MSM
88E405 or 74E405	1.0 MSH	88E414 or 74E414	3.5 MSH
88E306 or 74E306	1.5 MSM	88E514 or 74E514	3.5 MSX
88E406 or 74E406	1.5 MSH	88E316 or 74E316	4.0 MSM
88E506 or 74E506	1.5 MSX	88E416 or 74E416	4.0 MSH
88E308 or 74E308	2.0 MSM	88E516 or 74E516	4.0 MSX
88E408 or 74E408	2.0 MSH	88E616 or 74E616	4.0 MSX
88E508 or 74E508	2.0 MSX	88E318 or 74E318	4.5 MSM
88E310 or 74E310	2.5 MSM	88E418 or 74E418	4.5 MSH
88E410 or 74E410	2.5 MSH	88E518 or 74E518	4.5 MSX
88E510 or 74E510	2.5 MSX	88E618 or 74E618	4.5 MSX
88E312 or 74E312	3.0 MSM	88E322 or 74E322	5.5 MSM
88E412 or 74E412	3.0 MSH	88E422 or 74E422	5.5 MSH
88E512 or 74E512	3.0 MSX	88E522 or 74E522	5.5 MSX
		88E622 or 74E622	5.5 MSX

Goodrich data is based on catalog published by Goodrich Aerospace Power Transmission Corporation.

*Goodrich is a trademark and/or a trade name of Goodrich Aerospace.

This trade name, trademark and/or registered trademark is used herein for product comparison purposes only, is the property of the respective owner and is not owned or controlled by Emerson Power Transmission Corporation. Emerson Power Transmission does not represent or warrant the accuracy of this document.

Kop-Flex engineering staff, the largest in the industry, enables us to work closely with customers to solve problem applications. Kop-Flex will custom-design and manufacture special couplings for your specific requirements.

The following are some of typical examples of specialty couplings:

High speed, test stand disc/gear coupling designed specifically to avoid system critical speeds.

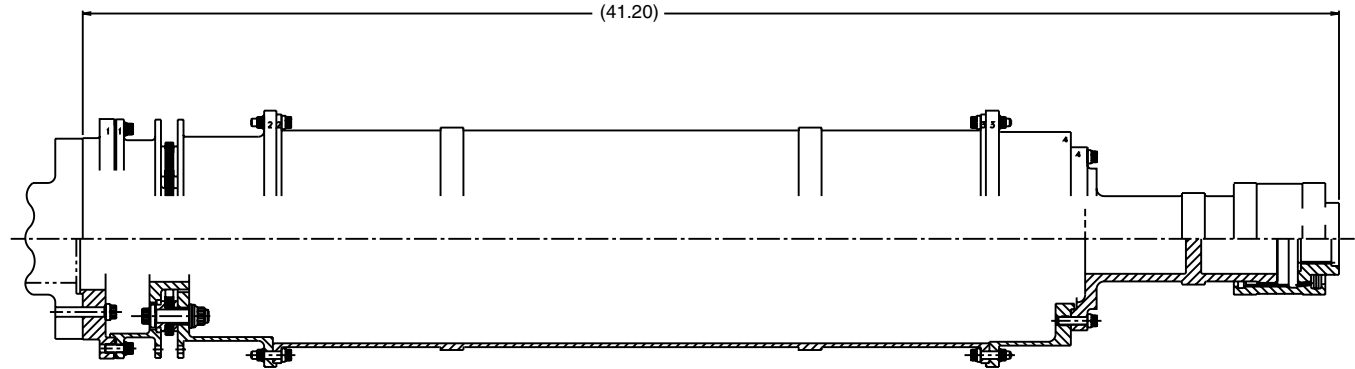

This coupling solved lateral, critical speed and overhung weight problems that the customer was experiencing with a competitor's coupling.

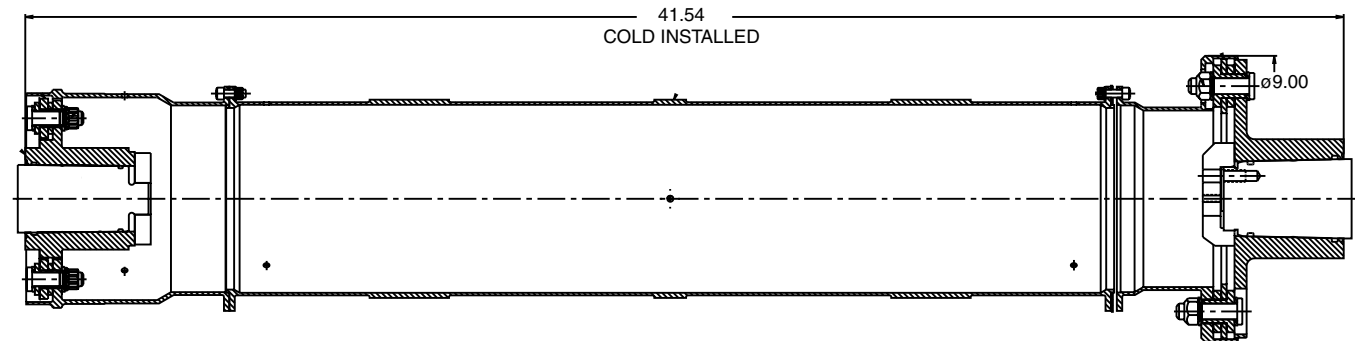

This coupling was designed to meet the customers need for weight reduction. The coupling weight is reduced by 45 percent compared to a competitor's coupling.

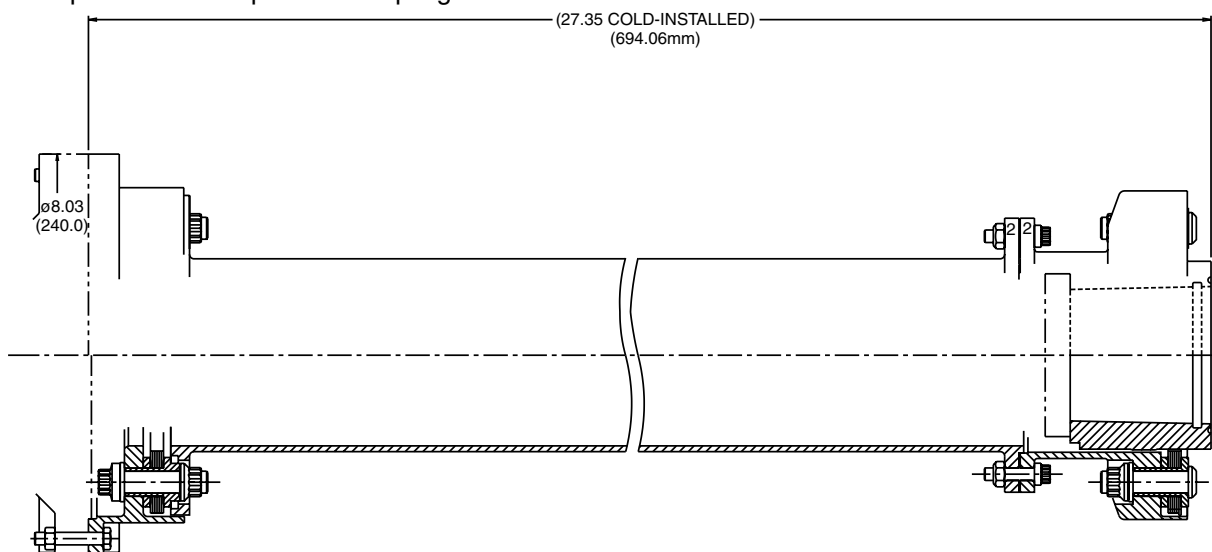

As the largest, high performance, industrial coupling supplied in the industry, this design was used on a gas turbine to steam turbine application - 257,000 HP (191,650 kW) at 3,000 rpm. The coupling was specially designed with back-up gear to accommodate 30.5 million in-lb short circuit torque.

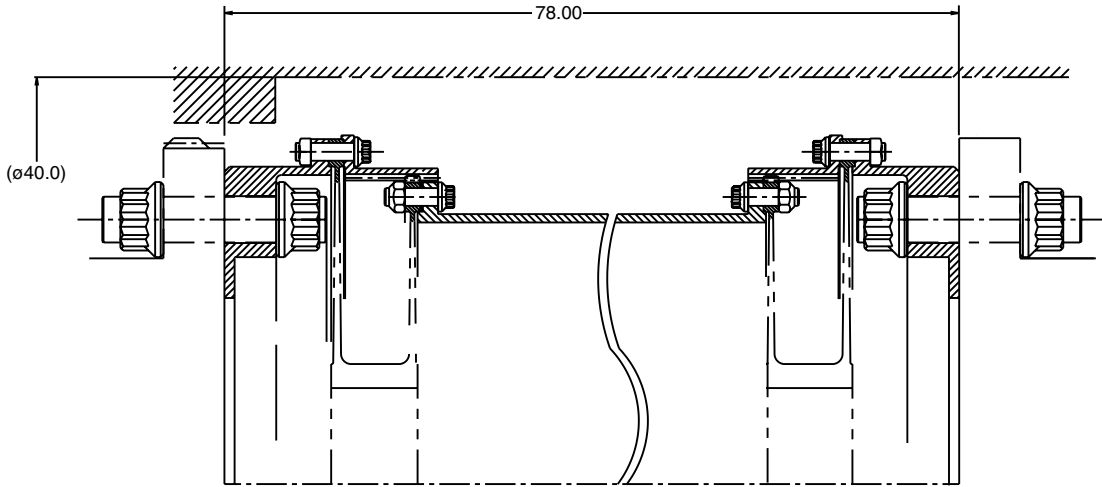

These double, piloted, patent pending, moment simulators were specially designed for at-speed balance on high speed rotors.

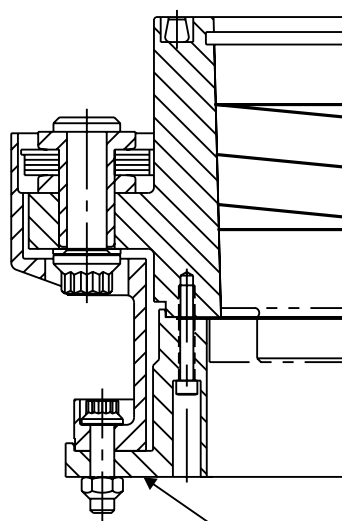

DOUBLE PILOTED MOMENT SIMULATOR

Hydraulic removal of single or double-keyed hubs for straight or tapered bores was made easy using a Kop-Flex design featuring bore modifications and hydraulic tooling.

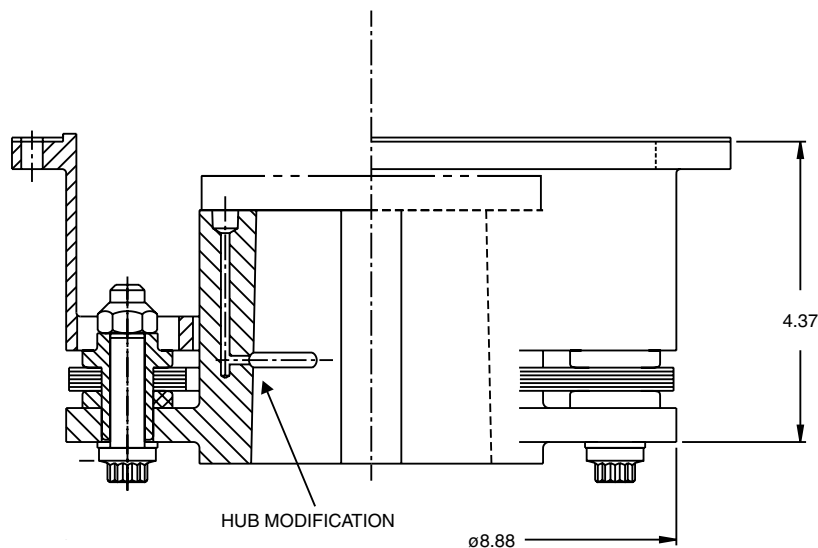

Moment Simulator for Sensitive Rotor Balance

High Speed Balancing for Rotors Requiring Reduced Moment Couplings

When do you need a special moment simulator?

For high speed turbomachinery applications with relatively small diameter shaft mounts – say 15000 rpm with 4 inch (100 mm) shaft mounts - a reduced moment flexible element coupling is a must to keep the rotor sensitivity to unbalance low.

When one of these rotors needs to be balanced at speed, it's best to simulate the effects of the coupling mass on the end of the rotor. This is particularly important if the rotor has an extra long overhang from the bearing or if the rotor will otherwise operate close to its lateral critical speed.

A one-piece “dummy” hub can be used to simulate the coupling mass and moment, but it's just not the same as if the actual coupling were mounted. It's difficult to simulate flexible element coupling parts with a solid piece of steel.



The Kop-Flex Patented Moment Simulator Solution for Sensitive Rotor Balance

To solve the problem, Kop-Flex has developed a patented, double-piloted moment simulator adapter for reduced moment couplings, which has Kop-Flex flexible pilot technology. This adapter precisely locates the hub, flexible element, spacer adapter (sleeve) in a concentric, locked, repeatable position, so that the balancing operations can occur.

The flexible pilots allow for high interference register fits that keep their interference. All parts are exactly centered during the low speed, coupling assembly-only balance, rotor shaft installation and the at-speed balance or balance-check operation.

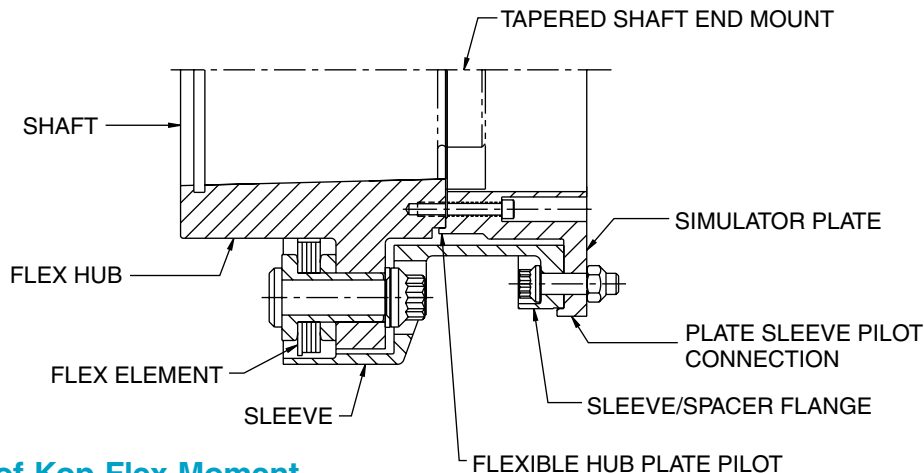

Advantages of Kop-Flex Moment Simulator Technology

- Flexible pilots with high interference fits
- Parts are exactly centered
- Part centering and balancing is repeatable
- Plate is designed to simulate overhung moment of the coupling in normal operation

When you need a solution, call Kop-Flex at 410-768-2000 or email coupling-engineering@emerson-ept.com or visit us at www.kopflex.com.

Kop-Flex Moment Simulator is a patented design under United States patent Number 6,685,570.

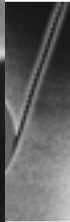

Gearing



Bearings

Backed by Emerson — A Global Market Leader

Kop-Flex is part of Emerson Power Transmission Corp., a manufacturing and marketing subsidiary of Emerson. Emerson is a global leader in uniting technology and engineering to deliver innovative solutions in industrial automation, process control, climate technologies, network power, appliances and tools.

Emerson Power Transmission has a primary objective - to excel as a major producer of power transmission drives, components, gearboxes and bearings for each of the principal markets it serves. The company is composed of four business units, plus two international joint ventures, brought together with complementary product lines into a single, flexible marketing entity. Well-known brands include Kop-Flex, Browning, Morse, Sealmaster, McGill, USGM and Rollway. The corporation's extensive manufacturing and distribution network supports over 3,000 industrial distributor locations worldwide and also sells directly to OEMs.

From the beginning, the corporate mission has been to provide superior quality products and customer service, creating an environment of continuous improvement where outstanding people make a difference.

High Performance Gear Couplings AC Series For High Speed Requirements

Application

The Series AC coupling design is intended for high performance applications featuring high speed and/or high torque operating conditions. The actual capacity of the coupling is a function of the combination of load, speed and alignment accuracy. The material used is low alloy steel, heat-treated to attain optimum properties of strength, hardness and toughness. The properties of the material in the heat-treated state, therefore, allow for much higher torque loads than for other coupling classifications that use carbon steel.



Description

The Series AC coupling is held to the close manufacturing tolerances consistent with industrial practice. These highly accurate tolerances allow the coupling to be more accurately, dynamically balanced and also allow inherently higher torque capacities than if the manufacturing tolerances were equivalent to the standard type coupling. The mating flanges of the coupling and spacers used are positioned to each other by accurately turned rabbets to maintain repetitive, accurate, dynamic balance in case the coupling is ever disassembled. The root of the sleeve teeth and this spherical, major diameter of ball of the hub teeth are closely fitted to maintain accurate concentricity. This is important in maintaining dynamic balance.



Installation

A common application of the Class AC coupling is in turbine driven equipment where thermal growth and distortion are substantial. This thermal growth under operating conditions should be accurately known and compensated for accordingly.

After installation and cold alignment, the equipment should be run and brought up to operating temperature. The alignment should then be checked in the hot condition using the hub sections that project beyond the sleeve end ring as reference points. This operation can be accomplished without disassembling the coupling.

High Performance gear couplings require lubrication, either continuous or batch. Continuous, lubricated couplings require a clean, filtered oil supply to the coupling and a coupling guard complete with oil supply and drain lines. Batch lubricated couplings can be used for low or moderate speeds where the coupling can be packed with KHP grease at installation. All lubricated couplings require maintenance attention to prevent contamination and sludge accumulation, which can reduce coupling life or degrade the coupled machine performance.

The Series AC coupling is dynamically balanced and must be assembled with parts in the same relative position as when balanced by the factory. Match marks are scribed on all parts to permit proper assembly and reassembly. Bolts and nuts are individually weight balanced, which allows the interchanging of any bolt with any nut.

ACCS/RM Gear Coupling Continuous Lubrication Sizes #1 1/4 - #7

ACCS/RM nomenclature denotes:
 AC - Series AC coupling
 C - continuous oil lubrication
 S - oil introduced thru the spacer
 RM - reduced moment

- Lightweight
- Low overhung moment

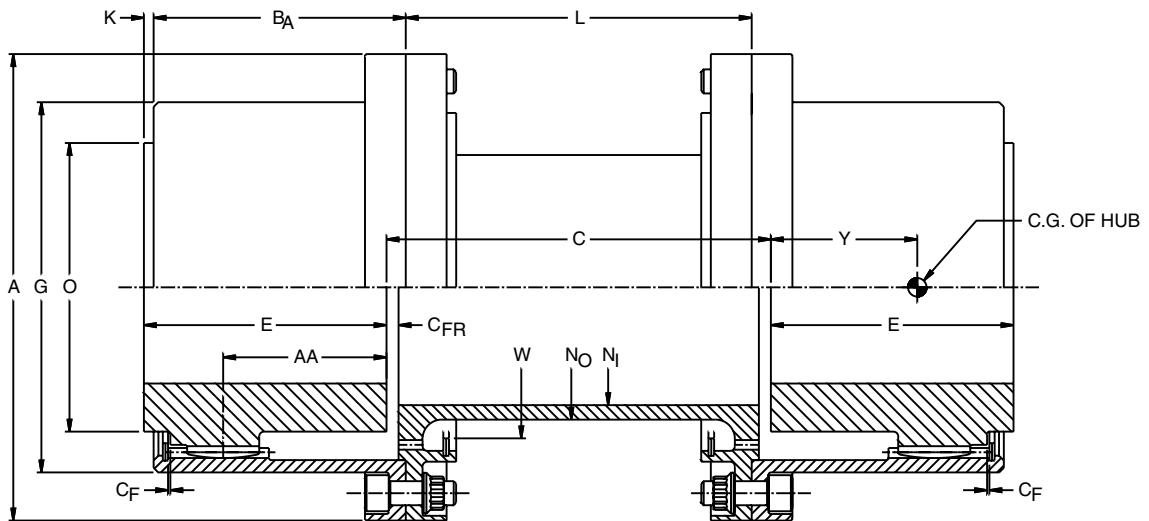
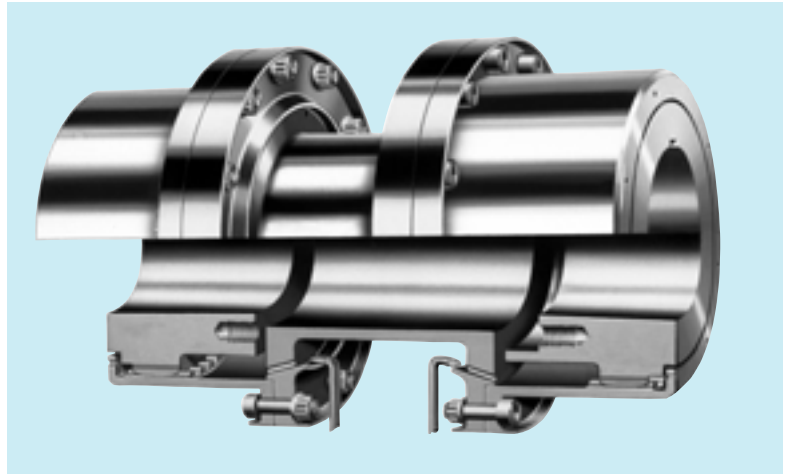

SIZE	DIMENSIONS (INCHES)																SIZE	
	A	C	C _A	C _F	C _{FR}	G	L	N _I	N _O	O	W	LONG HUB						
												BORE	E	B	BA	A-A		Y
1 1/4	4 3/32	5	3/16	1/32	1/8	3 1/16	4 5/8	1 1/2	1 3/4	2 1/4	2 3/8	1 1/2	1 7/8	8 3/4	2 1/16	1.28	.97	1 1/4
1 1/2	5	5	73/2	1/16	1/8	3 31/32	4 9/16	1 7/8	2 1/4	3	3 3/16	2	2 7/16	9 7/8	2 21/32	1.69	1.25	1 1/2
2	6 1/16	5	1/4	1/16	5/32	4 13/16	4 1/2	2 5/8	3	3 3/4	3 15/16	2 1/2	3 1/32	11 1/16	3 9/32	2.13	1.58	2
2 1/2	7	5	9/32	3/32	3/16	5 11/16	4 7/16	3 11/32	3 3/4	4 1/2	4 3/4	3	3 19/32	12 3/16	3 7/8	2.50	1.88	2 1/2
3	8 3/16	5	9/32	3/32	3/16	6 21/32	4 7/16	4 1/16	4 1/2	5 1/4	5 9/16	3 1/2	4 3/16	13 3/8	4 15/32	2.98	2.19	3
3 1/2	9 5/16	7	5/16	1/8	3/16	7 31/64	6 3/8	4 3/4	5 1/4	6	6 3/8	4	4 3/4	16 1/2	5 1/16	3.31	2.38	3 1/2
4	10 1/2	7	3/8	1/8	1/4	8 1/2	6 1/4	5 1/2	6	6 3/4	7 3/16	4 1/2	5 5/16	17 5/8	5 11/16	3.78	2.72	4
4 1/2	11 9/16	7	3/8	5/32	1/4	9 17/32	6 1/4	6 3/16	6 3/4	7 1/2	8	5	6 1/32	19 1/16	6 13/32	4.30	3.14	4 1/2
5	13 13/16	10	7/16	5/32	5/16	11 1/4	9 1/8	7 9/16	7 1/2	9	9 5/8	6	7 13/32	24 13/16	7 27/32	5.34	3.88	5
6	16 3/16	10	1/2	3/16	3/8	13 3/16	9	9	9	10 1/2	11 1/8	7	8 11/16	27 3/8	9 3/16	6.47	4.55	6
7	18 1/4	12	1/2	3/16	3/8	15 1/4	11	10 13/32	10 1/2	12	12 7/8	8	9 23/32	31 7/16	10 7/32	7.41	5.13	7

Contact Kop-Flex for larger sizes.
 See page 72 for maximum bore capacity.

ACCS/RM Gear Coupling Continuous Lubrication Sizes #1 1/4 - #7

ACCS/RM nomenclature denotes:
 AC - Series AC coupling
 C - continuous oil lubrication
 S - oil introduced thru the spacer
 RM - reduced moment

- Lightweight
- Low overhung moment

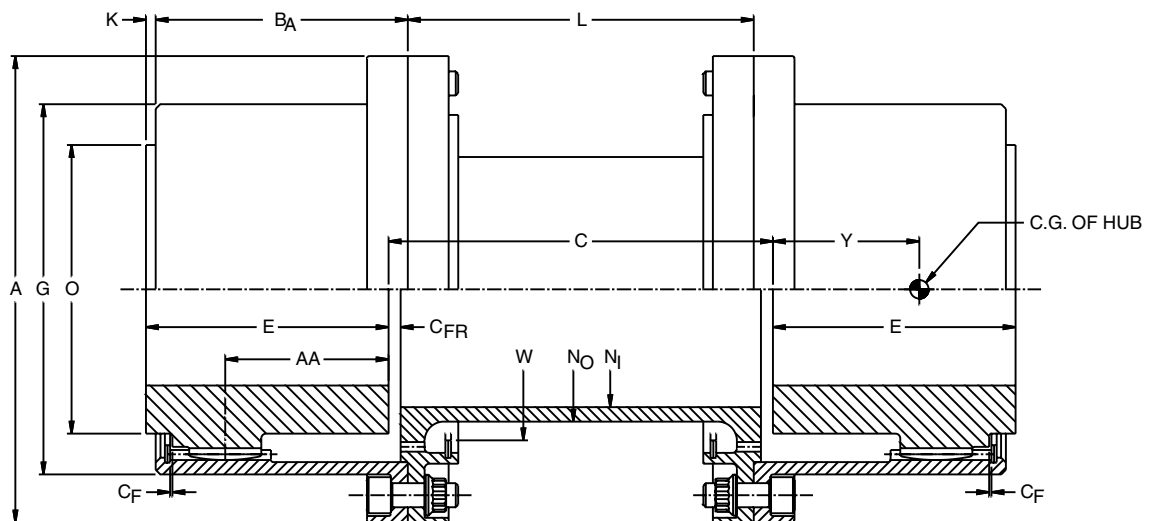
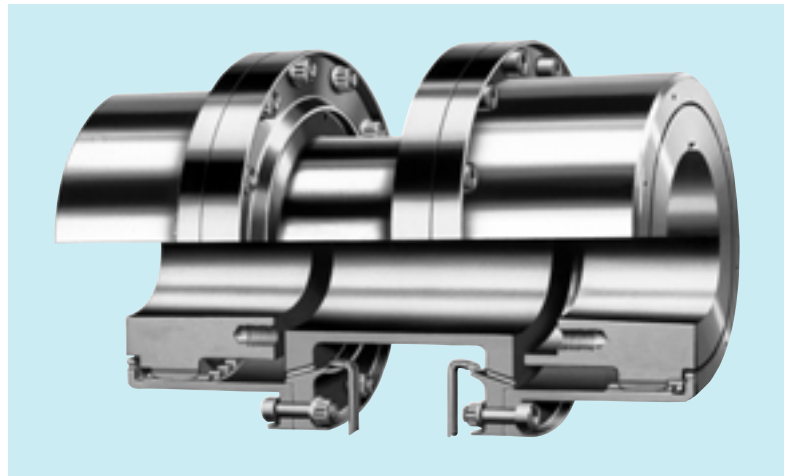

SIZE	DIMENSIONS (mm)											LONG HUB						SIZE
	A	C	CA	CF	CFR	G	L	NI	NO	O	W	BORE	E	B	BA	A-A	Y	
	1 1/4	104	127	5	0.8	3.2	78	117	38	44	57	60	38	48	222	53	33	
1 1/2	127	127	6	1.6	3.2	101	116	48	57	76	81	51	62	251	67	43	62	1 1/2
2	154	127	6	1.6	4.0	122	114	67	76	95	100	64	77	281	83	54	40	2
2 1/2	178	127	7	2.4	4.8	144	113	85	95	114	121	76	91	310	98	64	48	2 1/2
3	208	127	7	2.4	4.8	169	113	103	114	133	141	89	106	340	114	76	56	3
3 1/2	237	178	8	3.2	4.8	190	162	121	133	152	162	102	121	419	129	84	60	3 1/2
4	267	178	10	3.2	6.4	216	159	140	152	171	183	114	135	448	144	96	69	4
4 1/2	294	178	10	4.0	6.4	242	159	157	171	191	203	127	153	484	163	109	80	4 1/2
5	351	254	11	4.0	8.0	286	232	192	191	229	244	152	188	630	199	136	99	5
6	411	254	13	4.8	9.6	335	229	229	229	267	283	178	221	695	233	164	116	6
7	464	305	13	4.8	9.6	387	279	264	267	305	327	203	247	799	260	188	130	7

Contact Kop-Flex for larger sizes.
 See page 72 for maximum bore capacity.

ACCS/RMD Gear Coupling Continuous Lubrication Sizes #1 1/2 - #7

ACCS/RMD nomenclature denotes:
 AC - Series AC coupling
 C - continuous oil lubrication
 S - oil introduced thru the spacer
 RM - reduced moment
 D - Damless

- Lightweight
- Damless

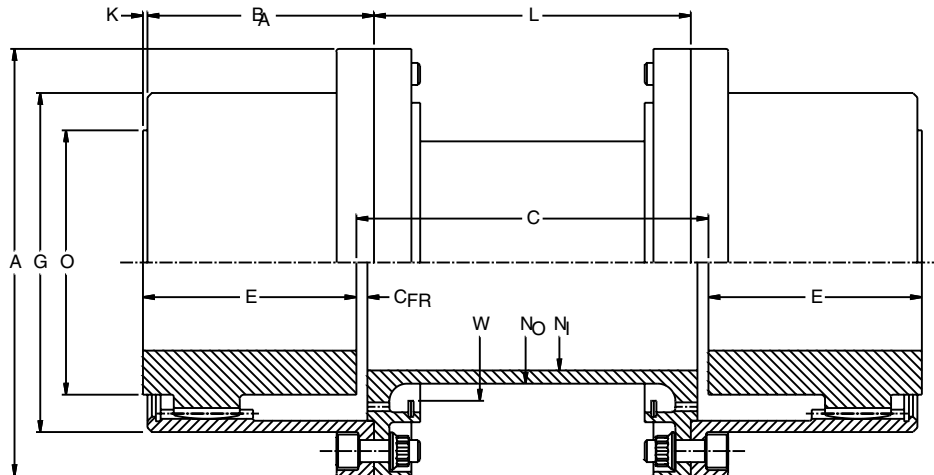
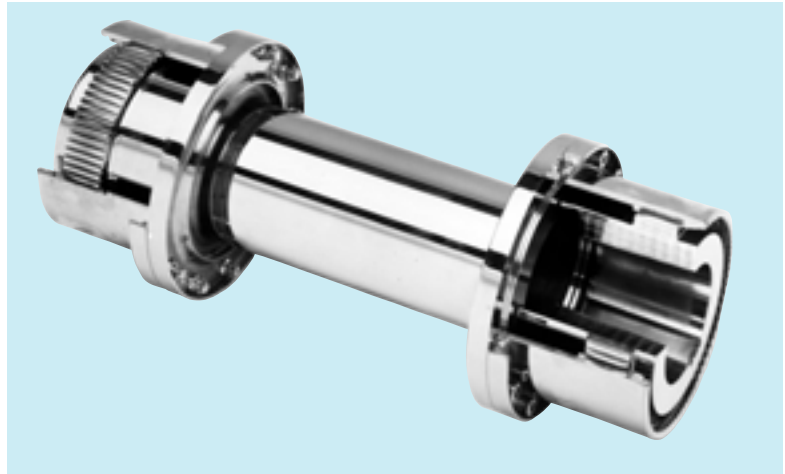

Size	DIMENSIONS (in.)										
	A	BA	"Std" C Shaft Sep.	CFR	E Fit Length	G	K	"Std" L Spacer Length	W Oil Inlet	NO	NI
1.5	5.00	2.59	5	0.12	2.44	3.97	0.06	4.56	3.19	2.25	1.88
2.0	6.06	3.22	5	0.16	3.03	4.81	0.06	4.50	3.94	3.00	2.62
2.5	7.00	3.81	5	0.19	3.59	5.69	0.06	4.44	4.75	3.75	3.34
3.0	8.19	4.25	5	0.19	4.19	6.66	0.16	4.56	5.56	4.50	4.06
3.5	9.31	4.88	7	0.19	4.75	7.48	0.19	6.38	6.38	5.25	4.75
4.0	10.50	5.56	7	0.25	5.31	8.50	0.12	6.25	7.19	6.00	5.50
4.5	11.56	6.28	7	0.25	6.03	9.53	0.12	6.25	8.00	6.75	6.19
5.0	13.81	7.63	10	0.31	7.41	11.25	0.22	9.12	9.62	8.25	7.56
6.0	16.19	9.13	10	0.38	8.69	13.19	0.06	9.00	11.12	9.75	9.00
7.0	18.25	10.19	12	0.38	9.81	15.25	0.12	11.00	12.88	11.25	10.41

Contact Kop-Flex for larger sizes.
 See page 72 for maximum bore capacity.
 Damless couplings require increased lube flow. Consult Kop-Flex for recommendations.

ACCS/RMD Gear Coupling Continuous Lubrication Sizes #1 1/2 - #7

ACCS/RMD nomenclature denotes:

- AC - Series AC coupling
- C - continuous oil lubrication
- S - oil introduced thru the spacer
- RM - reduced moment
- D - Damless

- Lightweight
- Damless

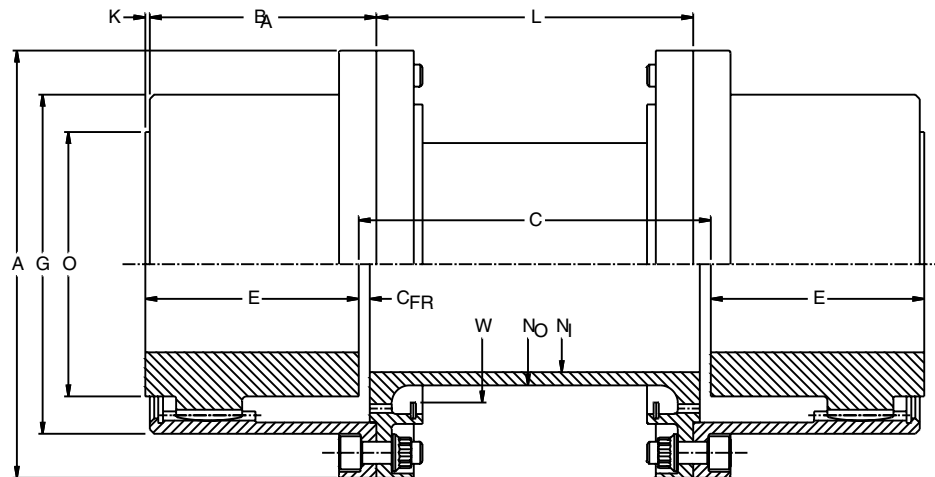
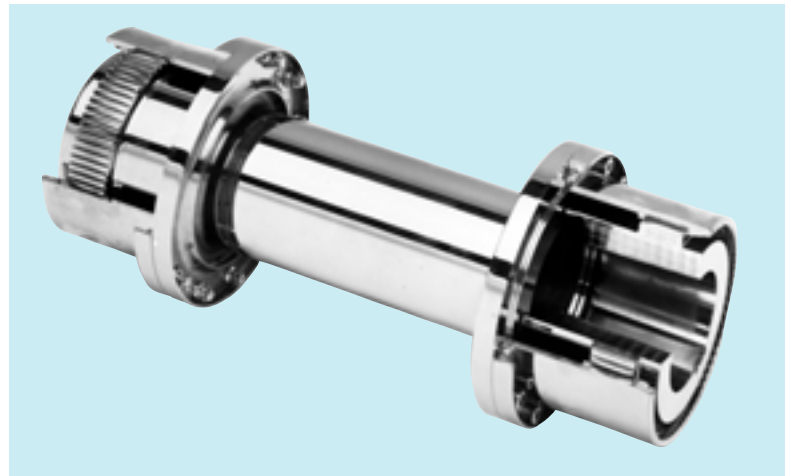

Size	DIMENSIONS (mm)										
	A	BA	"Std" C Shaft Sep.	C _{FR}	E Fit Length	G	K	"Std" L Spacer Length	W Oil Inlet	N _O	N _I
1.5	127	66	127	3.1	62	101	1.5	116	81	57	48
2	154	82	127	4.1	77	122	1.5	114	100	76	67
2.5	178	97	127	4.8	91	145	1.5	113	121	95	85
3	208	108	127	4.8	106	169	4.1	116	141	114	103
3.5	236	124	178	4.8	121	190	4.8	162	162	133	121
4	167	141	178	6.4	165	216	3.1	159	183	152	140
4.5	294	160	178	6.4	153	242	3.1	159	203	171	157
5	351	194	254	7.9	188	286	5.6	232	244	210	192
6	411	232	254	9.7	221	335	1.5	229	282	248	229
7	464	259	305	9.7	249	387	3.1	279	327	286	264

Contact Kop-Flex for larger sizes.

See page 72 for maximum bore capacity.

Damless couplings require increased lube flow. Consult Kop-Flex for recommendations.

ACPL Gear Coupling Continuous Lubrication Sizes #1 1/4 - #7

The ACPL nomenclature denotes:
AC - Series AC coupling
PL - packed lubrication

- Packed lube w/KHP Grease
- Low to moderate speed range
- No oil nozzles

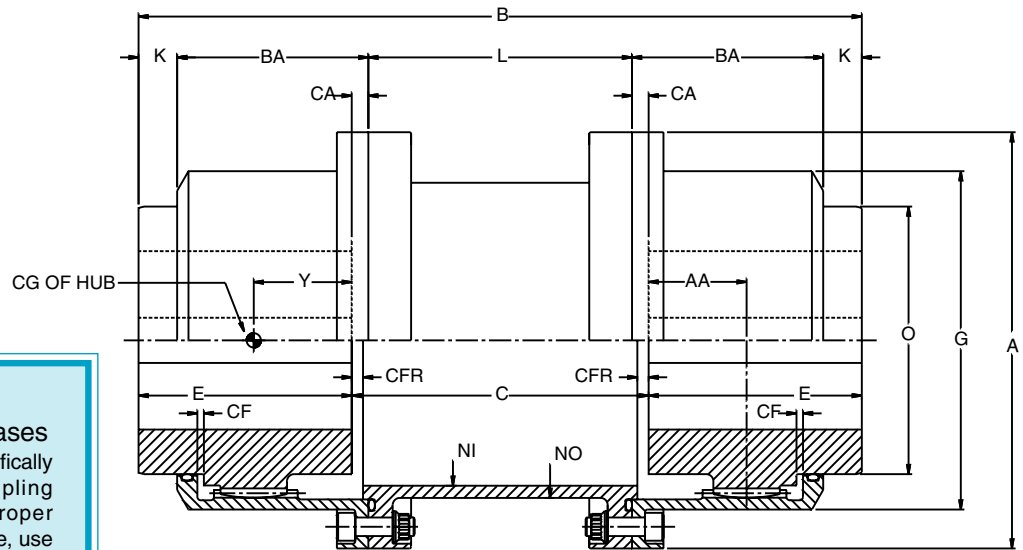
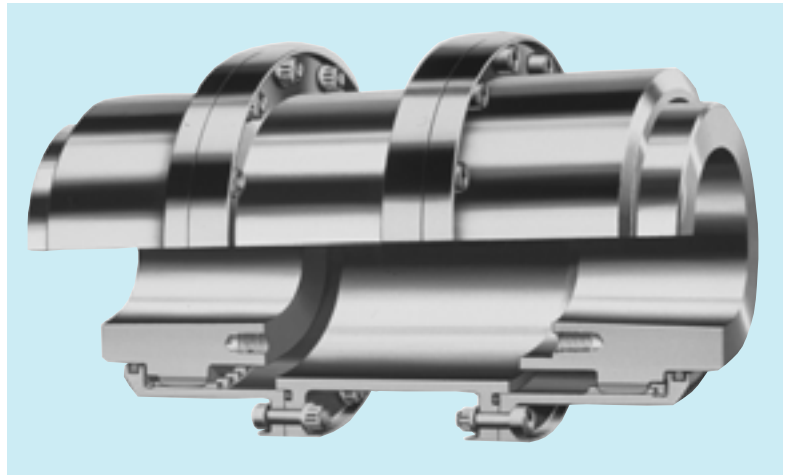

Kop-Flex Coupling Greases
Kop-Flex offers greases specifically designed for use in coupling applications. To provide proper lubrication and long service life, use Kop-Flex KSG standard coupling grease, or KHP high performance coupling grease. See page 87 for detailed specifications.

SIZE	DIMENSIONS (in.)														SIZE			
	A	B _A	C	C _A	C _F	C _{FR}	G	L	N _i	N _o	O	A-A	MAXIMUM BORE					
													BORE	E		B	K	Y
1 1/4	4 3/32	1 19/32	5	3/16	1/32	1/8	3 1/16	4 5/8	2 15/32	2 23/32	2 1/4	.69	1 1/2	1 7/8	8 3/4	15/32	.90	1 1/4
1 1/2	5	2	5	7/32	1/16	1/8	3 31/32	4 9/16	3 5/16	3 9/16	3	.85	2	2 7/16	9 7/8	21/32	1.17	1 1/2
2	6 1/16	2 19/32	5	1/4	1/16	5/32	4 13/16	4 1/2	4 1/16	4 25/64	3 3/4	1.25	2 1/2	3 1/32	11 1/16	11/16	1.50	2
2 1/2	7	3 7/32	5	9/32	3/32	3/16	5 11/16	4 7/16	4 57/64	5 19/64	4 1/2	1.65	3	3 19/32	12 3/16	21/32	1.79	2 1/2
3	8 3/16	3 3/4	5	9/32	3/32	3/16	6 21/32	4 7/16	5 45/64	6 5/32	5 1/4	1.98	3 1/2	4 3/16	13 3/8	23/32	2.09	3
3 1/2	9 5/16	4 3/8	7	5/16	1/8	3/16	7 31/64	6 3/8	6 1/2	7 1/32	6	2.38	4	4 3/4	16 1/2	11/16	2.30	3 1/2
4	10 1/2	4 15/16	7	3/8	1/8	1/4	8 1/2	6 1/4	7 3/8	7 31/32	6 3/4	2.63	4 1/2	5 5/16	17 5/8	3/4	2.62	4
4 1/2	11 9/16	5 1/2	7	3/8	5/32	1/4	9 17/32	6 1/4	8 7/32	8 27/32	7 1/2	3.02	5	6 1/32	19 1/16	29/32	3.01	4 1/2
5	13 13/16	6 9/32	10	7/16	5/32	5/16	11 1/4	9 1/8	9 7/8	10 5/8	9	3.47	6	7 13/32	24 13/16	1 9/16	3.70	5
6	16 3/16	7 19/32	10	1/2	3/16	3/8	13 3/16	9	11 3/8	12 5/16	10 1/2	4.56	7	8 11/16	27 3/8	1 19/32	4.38	6
7	18 1/4	8 25/32	12	1/2	3/16	3/8	15 1/4	11	13 1/4	14 1/4	12	5.63	8	9 23/32	31 5/8	1 7/16	4.94	7

Contact Kop-Flex for larger sizes.
See page 72 for maximum bore capacity.
Damless couplings require increased lube flow. Consult Kop-Flex for recommendations.

ACPL Gear Coupling Continuous Lubrication Sizes #1 1/4 - #7

The ACPL nomenclature denotes:
AC - Series AC coupling
PL - packed lubrication

- Packed lube w/KHP Grease
- Low to moderate speed range
- No oil nozzles

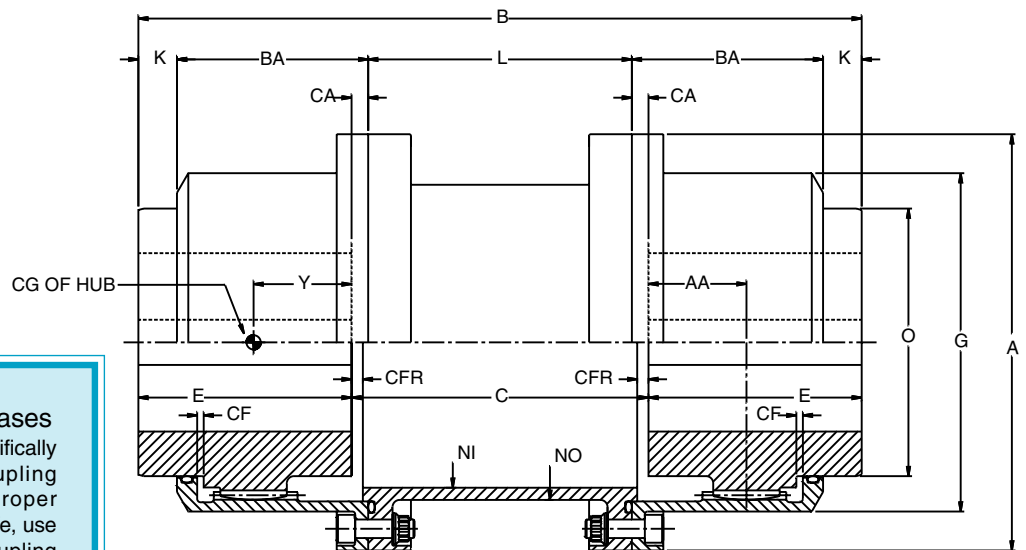
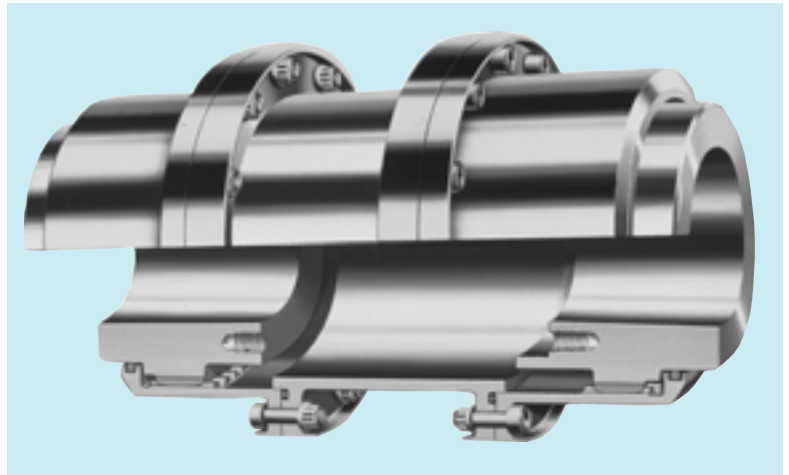

Kop-Flex Coupling Greases
Kop-Flex offers greases specifically designed for use in coupling applications. To provide proper lubrication and long service life, use Kop-Flex KSG standard coupling grease, or KHP high performance coupling grease. See page 87 for detailed specifications.

SIZE	DIMENSIONS (mm)													MAXIMUM BORE	SIZE				
	A	B _A	C	C _A	C _F	C _{FR}	G	L	N _I	N _O	O	A-A	BORE			E	B	K	Y
	1 1/4	104	40	127	5	0.8	3.2	78	117	63	69	57							
1 1/2	127	51	127	6	1.6	3.2	101	116	84	90	76	22	51	62	251	17	30	1 1/2	
2	154	66	127	6	1.6	4.0	122	114	103	112	95	32	64	77	281	17	38	2	
2 1/2	178	82	127	7	2.4	4.8	144	113	124	135	114	42	76	91	310	17	45	2 1/2	
3	208	95	127	7	2.4	4.8	169	113	145	156	133	50	89	106	340	18	53	3	
3 1/2	237	111	178	8	3.2	4.8	190	162	165	179	152	60	102	121	419	17	58	3 1/2	
4	267	125	178	10	3.2	6.4	216	159	187	202	171	67	114	135	448	19	67	4	
4 1/2	294	140	178	10	4.0	6.4	242	159	209	225	191	77	127	153	484	23	76	4 1/2	
5	351	160	254	11	4.0	8.0	286	232	251	279	229	88	152	188	630	40	94	5	
6	411	193	254	13	4.8	9.6	335	229	289	313	267	116	178	221	695	40	111	6	
7	464	223	305	13	4.8	9.6	387	279	337	362	305	143	203	247	799	37	125	7	

Contact Kop-Flex for larger sizes.
See page 72 for maximum bore capacity.
Damless couplings require increased lube flow. Consult Kop-Flex for recommendations.

ACCM Gear Coupling Continuous Lubrication Sizes #1 1/4 - #7

The ACCM nomenclature denotes:

- AC - Series AC coupling
- C - continuous oil lubrication
- M - Marine Style

- Marine Style
- Replace flex section without removing hubs

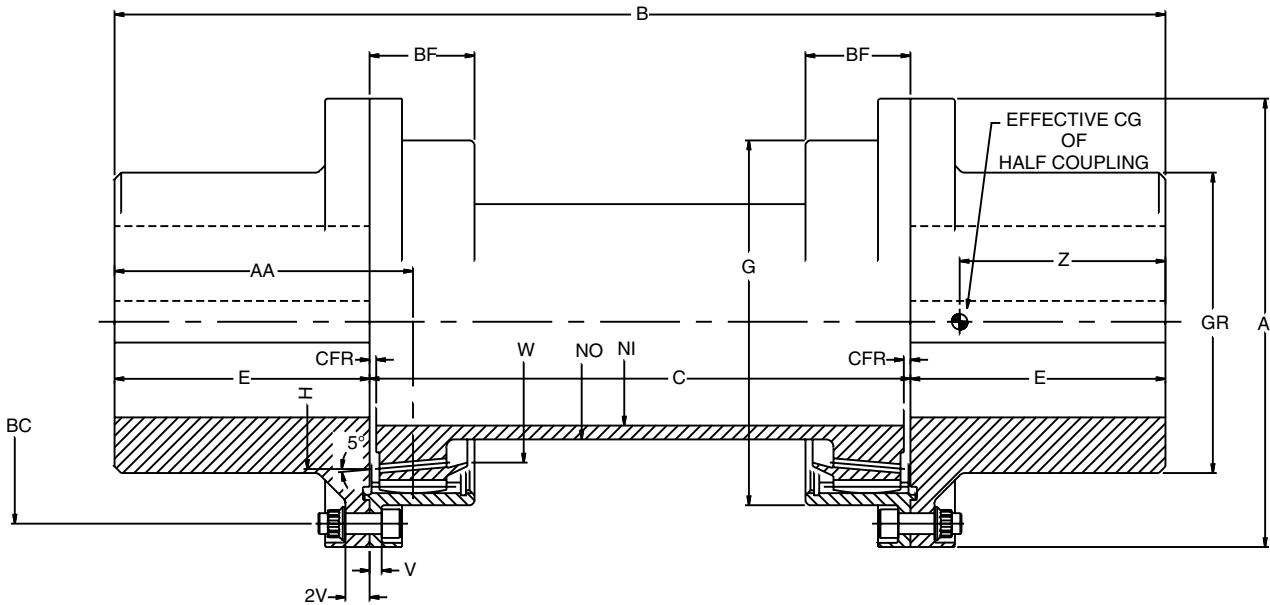
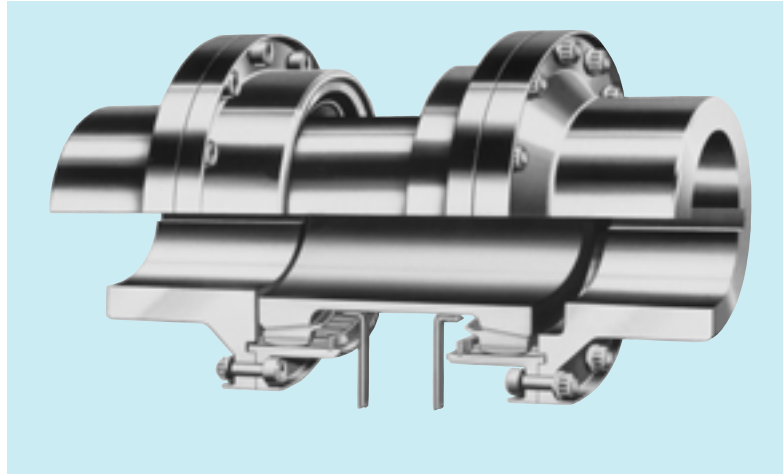

Size	DIMENSIONS (in.)																					
	SHORT RIGID HUB											LONG RIGID HUB										
	A	B _C	B _F	C	C _{FR}	G	N _I	N _O	V	W	BORE	E	B	G _R	A-A	Y	BORE	E	B	G _R	A-A	Y
1 1/2	5	4.410	1 11/32	5	3/32	3 3/32	1 11/16	2 1/8	5/32	2 7/8	1 1/2	1 7/8	8 3/4	2 1/4	2.41	1.58	2 1/2	2 7/16	9 7/8	3 3/4	2.97	1.58
2	6 1/16	5.350	1 17/32	5	3/32	4 15/16	2 5/16	2 13/16	7/32	3 9/16	2	2 7/16	9 7/8	3	3.06	1.94	3 1/8	3 1/32	11 1/16	4 1/2	3.66	1.93
2 1/2	7	6.270	1 3/4	5	1/8	5 11/16	3 1/4	3 11/16	7/32	4 7/16	2 1/2	3 1/32	11 1/16	3 3/4	3.78	2.26	3 7/8	3 19/32	12 3/16	5 7/16	4.34	2.19
3	8 3/16	7.330	1 29/32	5	1/8	6 21/32	3 13/16	4 5/16	7/32	5 1/8	3	3 19/32	12 3/16	4 1/2	4.41	2.61	4 1/2	4 3/16	13 3/8	6 3/8	5.00	2.53
3 1/2	9 3/16	8.280	2 1/4	7	5/32	7 31/64	4 3/8	4 15/16	1/4	5 13/16	3 1/2	4 3/16	15 3/8	5 1/4	5.16	2.98	4 7/8	4 3/4	16 1/2	7 1/8	5.72	2.29
4	10 1/2	9.400	2 13/32	7	5/32	8 1/2	4 13/16	5 1/2	9/32	6 9/16	4	4 3/4	16 1/2	6	5.84	3.33	5 5/8	5 5/16	17 5/8	8 1/16	6.40	3.22
4 1/2	11 9/16	10.450	2 7/8	7	3/16	9 17/32	5 3/8?	6 1/8	9/32	7 1/4	4 1/2	5 5/16	17 5/8	6 3/4	6.56	3.71	6 1/2	6 1/32	19 1/16	9 3/16	7.78	3.60
5	13 13/16	12.400	3 9/32	10	3/16	11 1/4	6 13/16	7 5/8	11/32	8 13/16	5	6 1/32	22 1/16	7 1/2	7.50	4.33	7 1/2	7 9/32	24 9/16	10 7/8	8.75	4.32
6	16 3/16	14.250	3 7/8	10	1/4	13 5/16	7 3/4	8 3/4	13/32	10	6	7 9/32	24 9/16	9	8.97	5.21	8 7/8	8 15/32	26 15/16	12 3/4	10.15	5.07
7	18 1/4	16.580	4 1/8	12	1/4	15 1/4	9 1/2	10 1/2	13/32	11 7/8	7	8 15/32	28 15/16	10 1/2	10.28	5.80	10 1/4	9 25/32	31 7/16	14 5/8	11.53	5.67

Contact Kop-Flex for larger sizes.

See page 72 for maximum bore capacity.

Damless couplings require increased lube flow. Consult Kop-Flex for recommendations.

ACCM Gear Coupling Continuous Lubrication Sizes #1 1/4 - #7

The ACCM nomenclature denotes:

- AC - Series AC coupling
- C - continuous oil lubrication
- M - Marine Style

- Marine Style
- Replace flex section without removing hubs

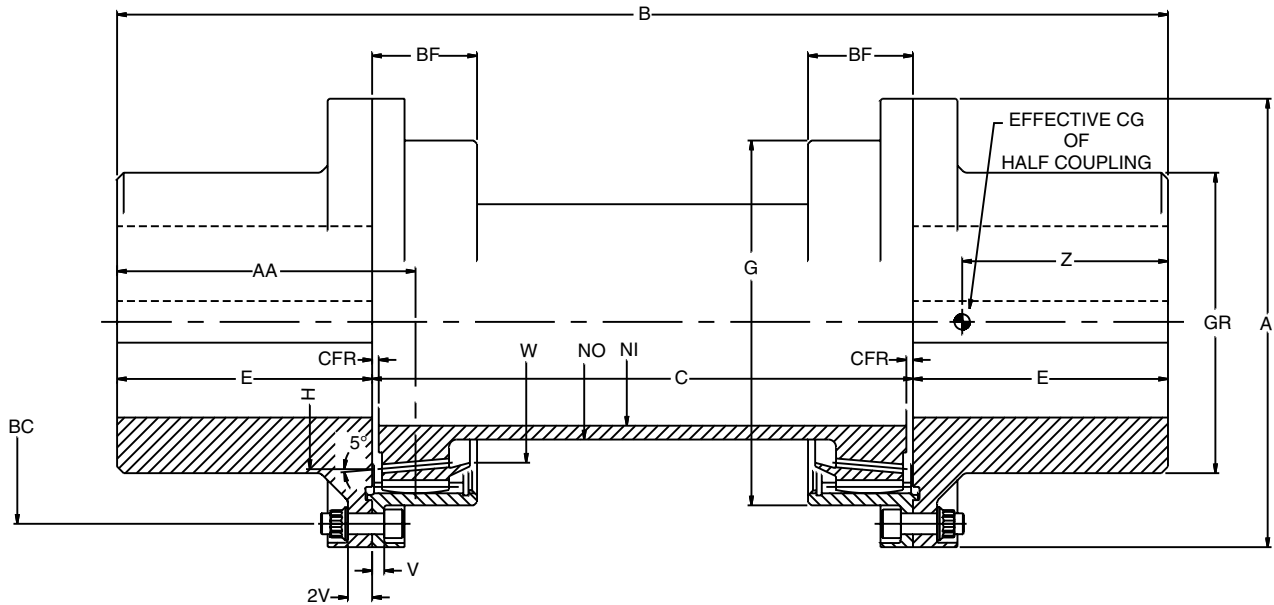
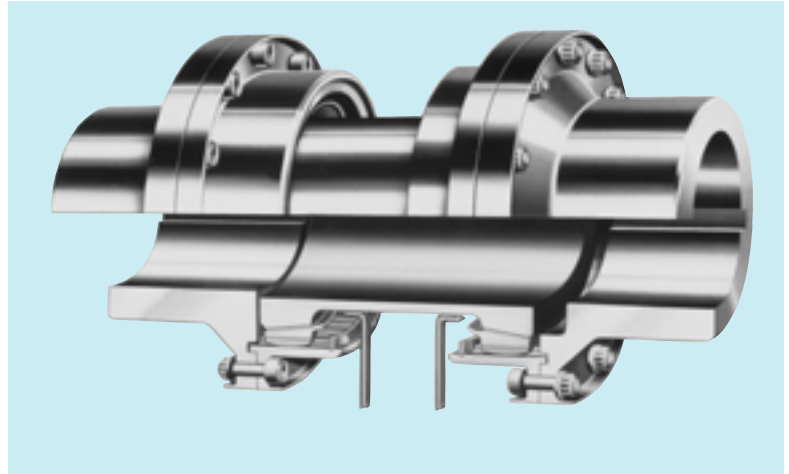

SIZE	DIMENSIONS (mm)																					
	A	B _C	B _F	C	C _{FR}	G	N _I	N _O	V	W	SHORT RIGID HUB						LONG RIGID HUB					
											BORE	E	B	G _R	A-A	Y	BORE	E	B	G _R	A-A	Y
1 1/2	127	112	31	127	3.1	79	43	54	4	73	38	48	222	57	61	40	64	62	251	95	75	40
2	154	136	39	127	2.4	125	59	71	6	90	51	62	251	76	78	49	79	77	281	114	93	49
2 1/2	178	159	44	127	3.2	144	83	94	6	113	64	77	281	95	96	57	98	91	310	138	110	56
3	208	186	49	127	3.2	169	97	110	6	130	76	91	210	114	112	66	114	106	340	162	127	64
3 1/2	237	83	57	178	4.0	190	111	125	6	148	89	106	391	133	131	76	124	121	419	181	145	58
4	267	239	61	178	4.0	216	122	140	7	167	102	121	419	152	148	85	143	135	448	205	162	82
4 1/2	294	265	73	178	4.8	242	137	156	7	184	114	135	448	171	167	94	165	153	484	233	198	91
5	351	315	83	254	4.8	286	173	194	9	224	127	153	560	191	191	110	171	185	624	276	222	110
6	411	362	98	254	6.4	338	197	222	10	254	152	185	624	229	228	132	225	215	684	324	258	129
7	464	421	105	305	6.4	387	241	267	10	302	178	215	735	267	261	147	260	248	799	371	293	144

Contact Kop-Flex for larger sizes.
See page 72 for maximum bore capacity.
Damless couplings require increased lube flow. Consult Kop-Flex for recommendations.

SELECTION EXAMPLE

EXAMPLE: Steam Turbine/Centrifugal Compressor (API 671 required; 1.75 application factor; reduced moment required on compressor shaft; 1/4° angular misalignment capacity required)

Turbine shaft - 6.0" tapered, keyless hydraulic
 Compressor shaft - 6" tapered, keyless hydraulic
 24" shaft separation
 Normal load: 42000 HP at 6000 RPM
 Continuous torque capacity required (lb-in.)
 $42000 \times 63025 \times 1.75 = 772100 \text{ lb-in.}$
 6000

SELECTION: #5.0 ACCS/RM

CLASS "AC" COUPLING SELECTION DATA

Size	Max. Bore Capacity (in.)	Max. Continuous Rating (lb-in.)	Peak Rating (lb-in)	Maximum Speed (rpm)
1.5	2.0	34000	45000	34400
2.0	2.5	66800	90000	28400
2.5	3.0	116000	160000	24600
3.0	3.5	182800	250000	21000
3.5	4.0	274200	375000	18500
4.0	4.5	390800	550000	16400
4.5	5.0	535700	750000	14900
5.0	6.0	926500	1250000	12500
6.0	7.0	1178600	2000000	10600
7.0	8.0	1471000	3000000	9420

Notes: (1) Max. continuous rating based on nitrided gearing.

SELECTION EXAMPLE

EXAMPLE: Steam Turbine/Centrifugal Compressor (API 671 required; 1.75 application factor; reduced moment required on compressor shaft; 1/4° angular misalignment capacity required)

Turbine shaft — 6.0" tapered, keyless hydraulic
 Compressor shaft — 6" tapered, keyless hydraulic
 24" shaft separation
 Normal load: 42000 HP at 6000 RPM
 Continuous torque capacity required (lb-in.)
 $42000 \times 63025 \times 1.75 = 772100 \text{ lb-in.}$
 6000

SELECTION: #5.0 ACCS/RM

CLASS "AC" COUPLING SELECTION DATA

Size	Max. Bore Capacity (mm)	Max. Continuous Rating (kNm)	Peak Rating (kNm)	Maximum Speed (rpm)
1.5	51	3.84	5.09	34400
2	64	7.55	10.1	28400
2.5	76	13.1	18.1	24600
3	89	20.7	28.3	21000
3.5	102	31.0	42.4	18500
4	114	44.2	62.2	16400
4.5	127	60.5	84.8	14900
5	152	105	141	12500
6	178	133	226	10600
7	203	166	339	9420

Notes: (1) Max. continuous rating based on nitrided gearing.

When ordering specify the following information:

- 1) Quantity and delivery requirements.
- 2) Shaft or bore sizes, keyway dimensions.
- 3) Load-horsepower and/or torque at a specific rpm. State normal (steady-state) and peak (transient) conditions.
- 4) Speed-minimum, normal maximum.
- 5) Application - type of driving and driven equipment.
- 6) Space limitations-envelope dimensions, and shaft separations.
- 7) Unusual misalignment conditions, normal and maximum.
- 8) Modifications and special requirements.
- 9) Unusual operating conditions-ambient temperature and atmosphere.

OTHER "AC" TYPES AVAILABLE

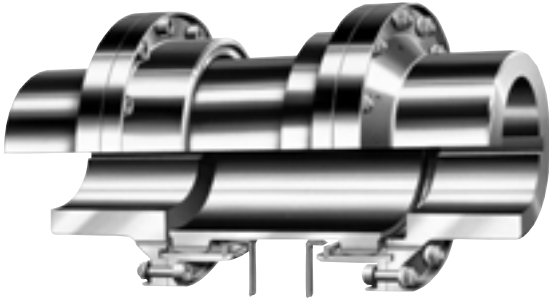

ACCR

Spool Type Coupling - Has greatest bore capacity, minimizing coupling size where shaft stresses are low.

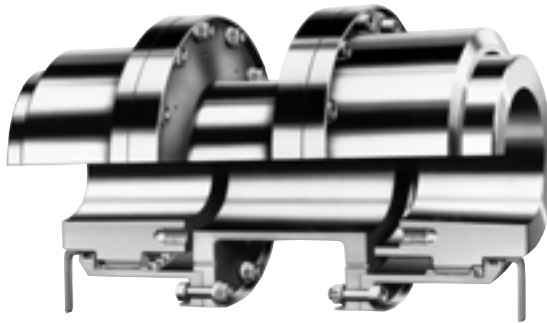

ACCL II

Provision for introducing lubrication oil at each end of coupling.

ACCL I

Where oil is introduced at one end only.



Also Designed for Specific Applications: Gas turbines load and accessories drives

Kop-Flex High Performance Gear Couplings

- Thousands in service
- Choose from straight or crowned nitrided gear teeth, depending on your application
- Precision lapped teeth, if required
- Heat treated, alloy components



Size #6 Gear Coupling
G.E. MS5001 Gas Turbine Driven
Compressor Train

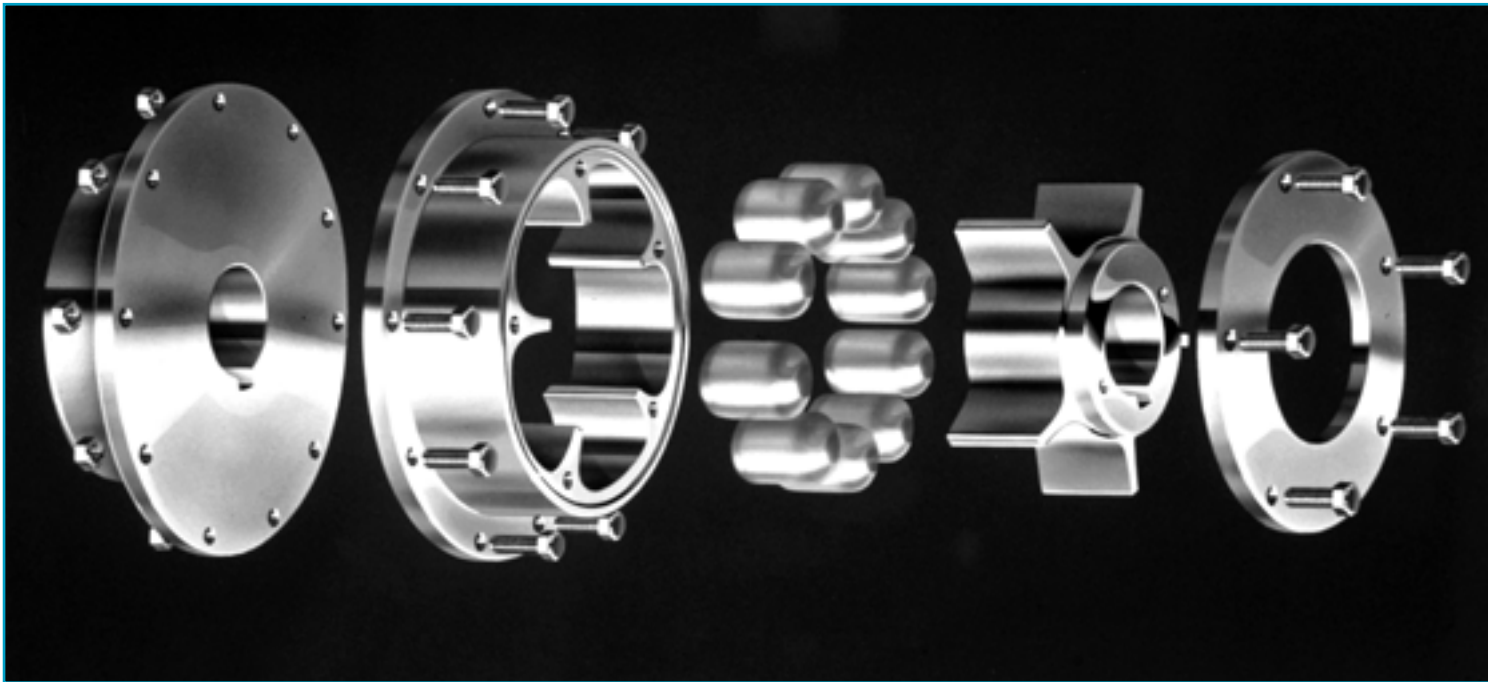

The Kop-Flex MAX-C Coupling Advantages:

- Transmits very high torque and cushions system shock.
- Never needs lubrication.
- Easy to assemble and install.
- Operates in wet, gritty, hot and other tough conditions.
- Can increase drive train and gear component life.
- Does not need routine maintenance.

Theory of Operation

A flexible coupling must perform two tasks: transmit torque from driving to driven shaft and accommodate shaft misalignments—angular, offset and axial. However, many applications require a third function. These applications involve severe torque fluctuations, starting and stopping of high inertia machinery, shock and impact loading and certain other types of torsional vibration problems characteristic of reciprocating equipment. This third function is to provide the proper degree of resilience and damping.

Resilience is the capacity of the coupling to assume relatively large torsional deflections under torque. That is what the MAX-C coupling supplies, a means to attenuate and dampen torsional shock loading and vibration while accommodating misalignment.

Coupling Design is the Key

Kop-Flex MAX-C couplings employ three principal components: an outer sleeve, an inner flex hub, both made of metal, and resilient drive blocks. When assembled, the flex hub and sleeve form cavities into which specially designed elastomer blocks are placed. The elastomer blocks are incompressible but the pockets allow block deformation under torque; the cavities are completely filled only under conditions of extreme overload and the coupling thus combines high load carrying capability with resilience. This provides smooth power transmission, day after day, year after year, without the coupling ever needing lubrication.

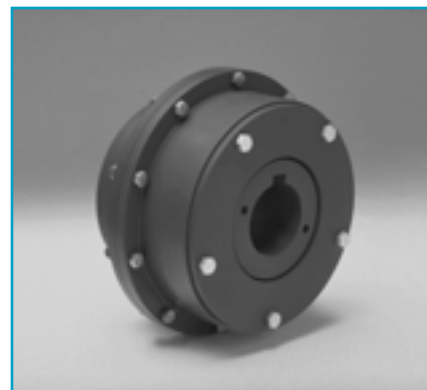

Superior Service Life

The Kop-Flex elastomer block materials (several different block compounds are available) are the key to the MAX-C's ability to provide consistent torque transmission with long service life. No other coupling will duplicate its performance and longevity. Block life is long, usually five years or more, but the blocks are easy to replace if useful service life has been reached. Replacing the blocks makes the coupling virtually as good as new.

Block Material

Type K2 and UB blocks are available in a single compound, MC elastomer, which is specially designed for long life and higher strength than rubber blocks. Maximum operating temperature for MC elastomer blocks is 175 °F.

Type WB and CB blocks are supplied in various compounds (natural, nitrile, and SBR high damping rubber) and various hardnesses (40 through 80 Shore 'A' hardness). Since these couplings are designed for engineered applications, the correct block compound and hardness is generally defined by a detailed torsional analysis, or by user experience. Special compounds are also available for specific properties such as high temperature or oil resistant characteristics.

"Fail-safe" Design

The inter-locking design of the hub and sleeve blades provide a coupling design that is inherently fail-safe. In the unlikely event that the blocks should suffer a complete failure, the coupling will continue to transmit torque through metal-to-metal contact of the inter-locking blades until the equipment can be shut down and the blocks replaced.

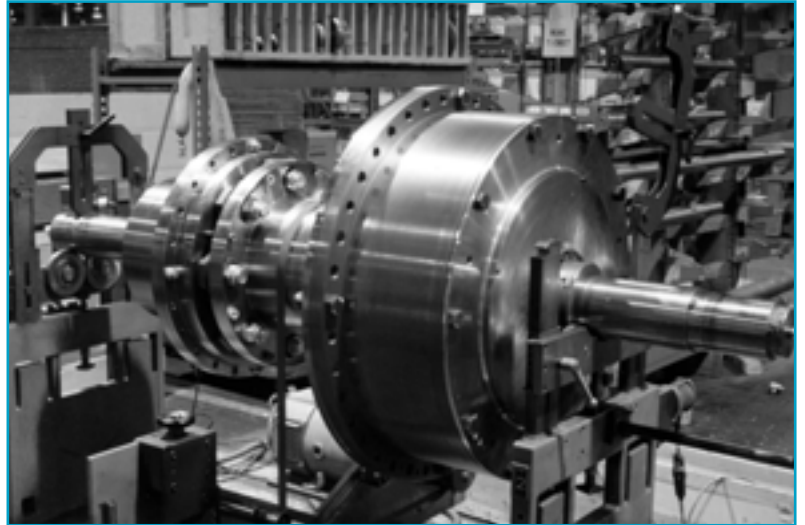

Selection of Coupling Type

The type of MAX-C coupling is selected based on the application and any specific requirements (torsional stiffness, damping, etc.) stated by the customer. Each type of coupling has specific torsional properties and should be selected accordingly.



Prime Mover		Max-C Coupling Type		
		Type K2/UB	Type CB	Type WB
Electric Motors	Crane Drives	●		
	Bow Thruster	●	●	
	Pumps	●		
	Reduction Gears	●		●
	Feed Rolls	●		●
	Fans	●		●
	Conveyors	●		
	Manipulators	●		●
Synchronous & Variable Frequency Motors	Centrifugal Compressors		●	●
	Speed Increaseers			●
	Mill Pinions			●
	Kiln Drives			●
	Crushers			●
Diesel Engines	ID & FD Fans			●
	Generator Sets		●	
	Fire Pumps		●	
	Torque Convertors		●	
	Marine Gears		●	
	Dynamometers		●	
	Drill Rigs		●	
	Main Propulsion		●	
Bow or Stern Thruster		●		

MAX-C “WB” Hybrids

The Solution Coupling for Synchronous and Variable Frequency Motor Applications with High Torsional Vibratory Loading

Some synchronous motors apply high vibratory torque loads to a drive train when they synchronize at start-up. Variable frequency motor trains can have high vibratory torque loads due to resonant frequency interference at certain operating speeds. To combat these loads the equipment can be increased in size, or damping can be introduced into the system to reduce the magnitude of these loads.

In many cases the costs are prohibitive to make the drive train shafts, gearboxes, and other equipment larger. The solution is to introduce damping. The MAX-C end of a MAX-C “WB” hybrid does this.

The damping provided by the high damping SBR rubber loaded in compression, along with the high shock load capacity of the “WB” wedge block cavity filling shape, make the MAX-C end of the hybrid the “damping” solution.

With a MAX-C on the motor end, the driven equipment does not have to be as large. But, the MAX-C coupling is much larger in diameter, weighs more, and is more costly than a standard high performance coupling. The driven equipment shaft and bearing cannot always support the increased weight.

So, the solution is to mate the MAX-C half with a standard more economical, lighter weight high performance coupling half.

The MAX-C hybrid is a MAX-C mated with a high performance diaphragm, a high performance disc, a KS disc, or a high performance or modified standard gear coupling, whichever is preferred or best suited to the application.

No matter which, Kop-Flex can engineer and manufacture the entire coupling, something no one else in the industry can do.

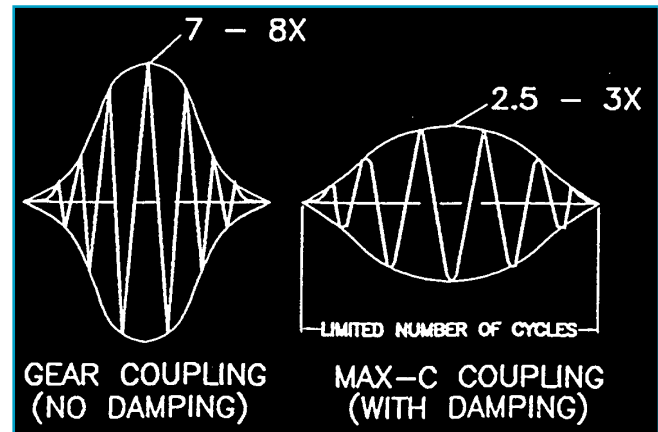

Torque Magnitude Reduction with a MAX-C

The MAX-C “WB” Hybrid Coupling Advantages

- Reduced torque loads for a smaller drive train
- Light weight, economical coupling design on the driven shafts
- SBR high damping rubber
- “WB” wedge block high shock load capacity
- No lubrication required on the MAX-C end



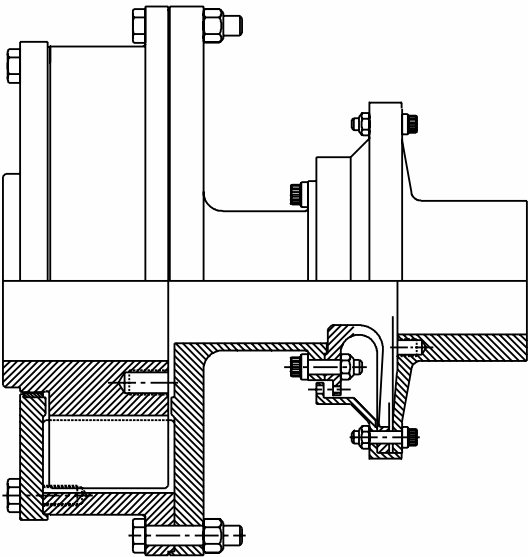

MAX-C "WB" / Diaphragm MS Coupling Hybrid

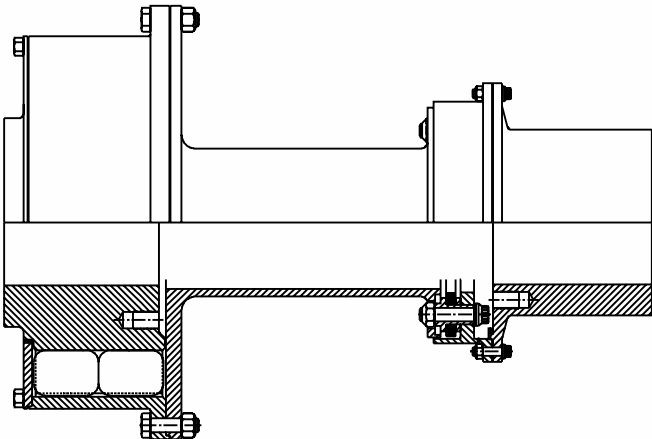

MAX-C "WB" / Kop-Flex MP Disc Coupling Hybrid

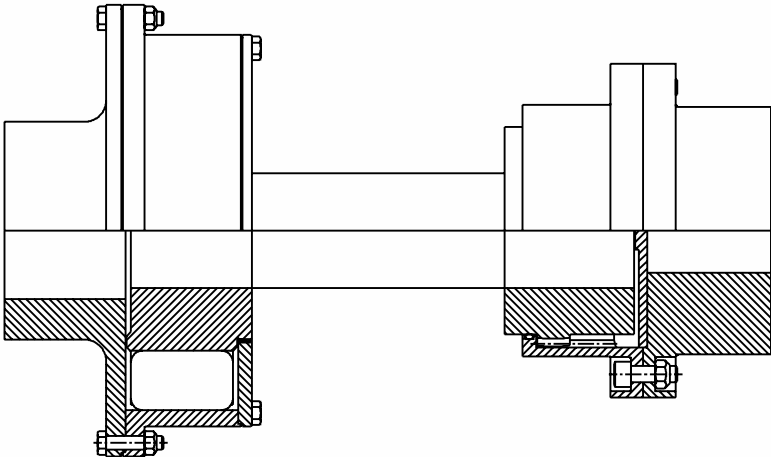

MAX-C "WB" / Gear Coupling Hybrid

KOP-FLEX®

Kop-Flex – The Widest Range of Coupling Solutions

Kop-Flex offers the broadest range of coupling products on the market today. From high performance, high-speed disc, diaphragm and gear couplings to off-the-shelf standard couplings, Kop-Flex also provides engineered gear, grid, jaw, elastomer, disc, universal joints and customized couplings to meet your unique application challenges.

Kop-Flex high performance couplings fulfill customers' needs for demanding turbomachinery applications such as steam or gas turbines; compressor, generator, motor driven drives; boiler feed pumps and special pumps for industries ranging from petrochemical, refinery, power plants, LNG, gas pipeline, test stands and more. Couplings meet API 671, ISO 10441, API 610, ISO 13709 and other industry standards.

Kop-Flex also offers coupling products for rolling mills and casters in steel mills, paper machines (both wet and dry ends), mines, liquid handling pumps and motors (for processing or liquid handling applications) and more.

A History of Innovation & Design Excellence

Powerlign Performance Torque Monitoring System for Coupling Applications

From the invention of Fast's – the world's first gear coupling – to today's high performance couplings, Kop-Flex has a rich industry background and a reputation for solving customer problems.

Faced with rising fuel costs and increasing environmental concerns such as No_x (*nitrous oxide*) emissions standards, torque meters are increasingly being used to measure power, speed and torque on critical rotating machine equipment.

Torque differentials can indicate performance problems such as blade fouling and over-torque can lead to coupling shaft or equipment failure. When performance declines, more fuel is burned and No_x emissions increase. Torque meters provide a cost-effective method for diagnosing these problems early on so you can make the necessary adjustments to your system for a proactive maintenance plan.

From Simple Diagnostics to True Control

As the only company in the world that has developed an integrated coupling-torque meter solution, Kop-Flex introduces the newly designed, digital Powerlign Performance Torque Monitoring System.

As the most reliable, accurate torque meter available in today's marketplace, the digital Powerlign replaces the proven, analog Powerlign system that has served the market for the last ten years. Powerlign features a patented, unique architecture that allows for more advanced system control with full integration support for distributed control systems (*DCS*) such as Emerson Process Management's DeltaV™ system or PCs and laptops for analyzing system data.

Powerlign acts as an important part of a closed loop system by establishing certain thresholds that can be configured to trigger an alert or alarm. Powerlign can also be used as a control system to shut down equipment or direct the in flow of gas or fuel to maintain load and efficiency.

Key Benefits

- All new, **digital** phase-shift, non-strain gauge system
- As a **single source supplier** of couplings and torque meters, Kop-Flex eliminates coordination and design integrity issues that occur with multiple suppliers
- Simplicity of design reduces margin for error—with accuracy within $\pm 1\%$
- **Safety and reliability** – unlike other torque measuring devices, no electronics or electrical power is present in the coupling or in the coupling environment
- **Seamless integration** – connect the Powerlign conditioning unit directly to a DCS like the DeltaV system or others running public or private MODBUS protocol, reducing the cost of setting another box or training your operator to use a new system
- **Retrofit** - For most applications, a new instrumented spacer can be inserted without disturbing the existing flex half couplings

No Other Torquemeter System Offers Consistent Accuracy

The accuracy rating is determined as a root sum of the squares series of all the individual errors possible, both electrical and mechanical.

The mechanical inaccuracies include allowances for the inevitable movements of the coupling in relation to the guard-mounted sensor, during hot and cold cycles of equipment operation. These are the radial gap and axial movement errors. Other mechanical errors are possible from the various calibrations and set-ups.

Electrical items include sensor variation and conditioning unit variation. Note that because these errors are included in the overall budget, sensors and boxes from the factory or stock can be swapped out in the field without degradation of accuracy. Powerlign and Powerwheel are accurate to within one percent.

- Specially configured MODBUS communication protocol available to fit with your **existing DCS**
- **Significant cost savings** – considering that a 40MW gas turbine consumes \$8,000,000/year in 2003 fuel costs, a one percent increase in efficiency equates to \$80,000 in annual savings
- Aids in **environmental compliance** efforts by helping to reduce No_x emissions through improved fuel monitoring
- **Completely interchangeable** components and no need for recalibration
- **Highly flexible** – fewer components, easier to install and no need to disturb or modify any vents, drains, filters, etc.
- ATEX, CE and CSA certification for explosion proof sensors (Div I), intrinsically safe conditioning unit and display unit (Div II) operation
- RS-232 digital, RS-485 digital and 4-20mA analog output
- Decreased lead times
- Reduced wiring cost
- Uses existing coupling guard
- User configurable imperial inch or metric (SI) units
- Built-in, automatic temperature compensation; sensors operate at temperatures as high as 350°F (177°C) to accommodate the most demanding environments



Powerlign and Powerwheel

Covering a Range of Applications

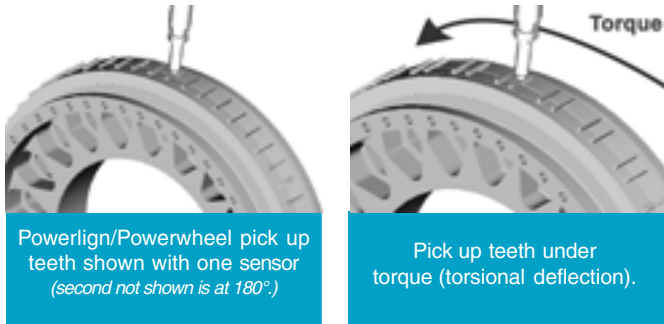

How Powerlign & Powerwheel Work

Powerwheel features the same patented design as Powerlign in a smaller footprint with a specifically profiled double-sided wheel, where teeth mounted to the outer diameter of one wheel move relative to teeth mounted on the mating wheel. Similar to Powerlign, sensors detect this movement but instead, deflection occurs in profiled spokes in each wheel in combination with a short, tubular section that connects the wheels.

Mechanical wheel or spacer – Powerlign includes intermeshed, pick-up teeth, mounted on a spacer on the coupling. The applied torque causes the spacer and wheel, to torsionally deflect, resulting in torsional twist.

In the Powerwheel design, the “twist for torque” measurement occurs in a compact, specifically profiled double wheel, where teeth mounted to the outer diameter of one wheel move relative to teeth mounted on the outer diameter of a mating wheel.

Sensors – two, monopole sensors, from reference points on the wheel, pick up this torsional twist. The sensors are mounted on the existing coupling guards by welding a boss plate to the guards, hence they do not rotate with the coupling and the pick-up teeth. The sensors are inserted into the boss plates, and the gap is set with a depth micrometer or feeler gauges. The boss plate orientations are usually installed at a 45° angle to avoid conflicts with drainpipes, vents, etc. As each set of teeth passes the sensor, a waveform is created.

Conditioning unit – the waveform is transmitted to a processor within the conditioning unit, which translates the twist into torque based on a series of measurements and constants. It also monitors the coupling’s speed and temperature. Internal circuits continuously use temperature information to automatically compensate for temperature-associated changes in coupling stiffness. Because processing occurs close to the sensors, greater

accuracy results due to reduced wire transmission.

The conditioning unit is mounted within 500 feet of the sensors and transmits data via cable, RS-485 and a public MODBUS protocol (an industry standard format, recognizable by most DCS). Powerlign can also be configured to transmit data over wireless networks or other communication protocols. *(Contact Kop-Flex for details.)* The conditioning unit also automatically checks and corrects itself every 24 hours for any electronic drift, eliminating the need for field calibration.

Standalone display unit – the standalone unit receives the digital signal and displays (but does not store) torque, speed and temperature data at approximately one-second intervals. Powerlign can transmit 4,000 feet whereas competitive designs only transmit up to 1,000 feet. This provides a greater range for signal transmission to the standalone display unit or the DCS, eliminating the need for expensive, cross-site cabling and providing flexibility in locating the diagnostic system. The display unit provides RS-232 digital and 4-20 mA analog output signals.

DCS *(in lieu of display unit)* – the conditioning unit can connect directly to your DeltaV or other DCS, via RS-485 cable or wireless (as an option) using public or private MODBUS protocol.

KOP-FLEX®

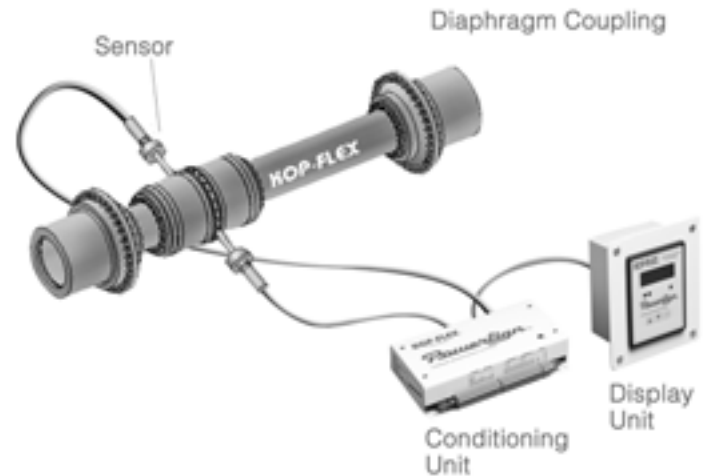

Powerlign with Conditioning Unit & Display

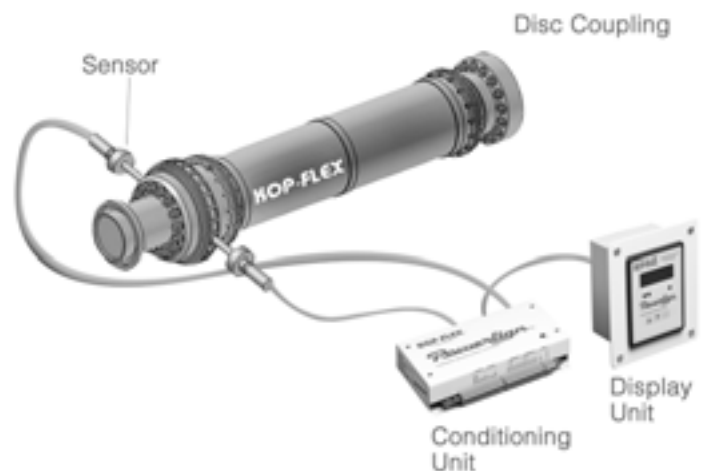

Powerwheel with Conditioning Unit & Display

The Origin of Powerwheel

To develop Powerwheel, Kop-Flex modified the same, proprietary, numerical analysis used for Kop-Flex diaphragm couplings then proved the design software with FEA, R&D and field tests. One back-to-back test connected a Powerlign torque meter directly to a Powerwheel torque meter, loaded with torque at high speeds. Each meter had a separate probe and an independent electronic system. Correlation results were excellent, within 0.3% of full-scale torque.

Major Customers and Applications

OEMS

Dresser Rand
Ebara
Elliot
G.E./A.C. Compressor
Man Turbo
Mitsubishi
Nuovo Pignone (GE)
Planergy
Rolls Royce
Siemens
Solar Turbine

Users:

BP Amoco
Exxon Mobil*
Linde Adnoc
Nova Chemical
Petrokemya
Petronas
SECL Malaysia
Sulzer
Syncrude
Transcanada Pipeline

Industries:

Petrochemical plants
Gas pipelines
Natural gas
Refineries
LNG
Test stands
Power plants
Marine propulsion
Energy storage

Applications:

Compressor to compressor
Motor to compressor
Performance testing
Turbine to boiler feed pump
Turbine (gas or steam)
to compressors
Turbine to generator
Test stands
Expander
Gas reinjection

*The first Powerlign unit shipped in 1995 and is still running continuously and successfully.

Capabilities	Powerlign	Powerwheel
Torque	<i>No upper limit</i>	<i>No upper limit</i>
Speed	<i>Typically up to 8,000 rpm</i>	<i>up to 20,000 rpm</i>
Shaft Separation	<i>18 to 48 inches (.5 to 1.2m)</i>	<i>5 to 180 inches (127 mm to 4.5m)</i>
Unbalanced Sensitivity	<i>For less sensitive</i>	<i>For most sensitive</i>
Retofit Application	<i>Well suited</i>	<i>Ideal</i>



Types of Torquemeters

Phase displacement torquemeter – measures coupling spacer twist when torque is applied by measuring the change in phase or shift between the two sets of pick-up teeth. Both Powerlign and Powerwheel are phase displacement torquemeters. Phase displacement is the better choice for long-term use because it provides uninterrupted service, higher accuracy and does not require field-calibration.

Strain gauge torquemeter – has a strain gauge or Wheatstone bridge attached to the spacer. An FM signal is transmitted to the processor through a stator ring. Although there have been many successful field installations, users consider the strain-gauge torquemeter as a weak system as it loses accuracy and reliability over time and has temperature limitations.



Retrofitting and Options

Covering a Range of Applications

LM 2500 Gas Turbine

Drop-In Powerwheel
into any existing
coupling

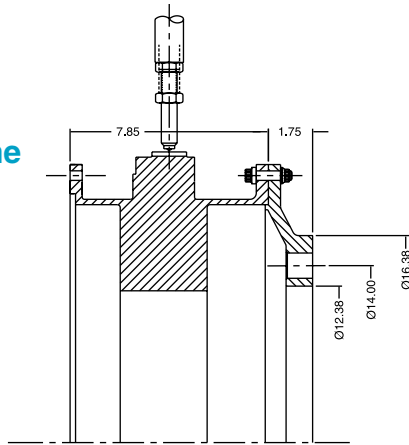

Retrofitting Existing Diaphragm Coupling

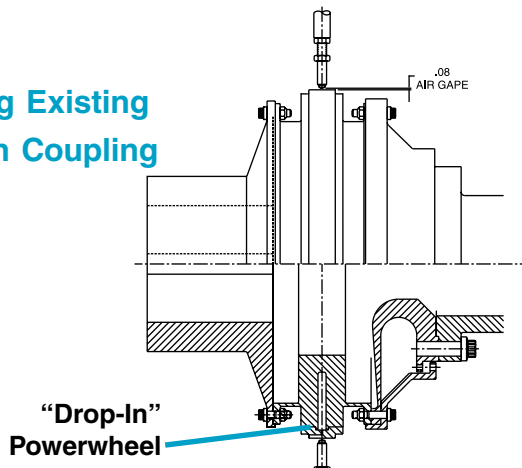

Retrofitting Existing Gear Coupling

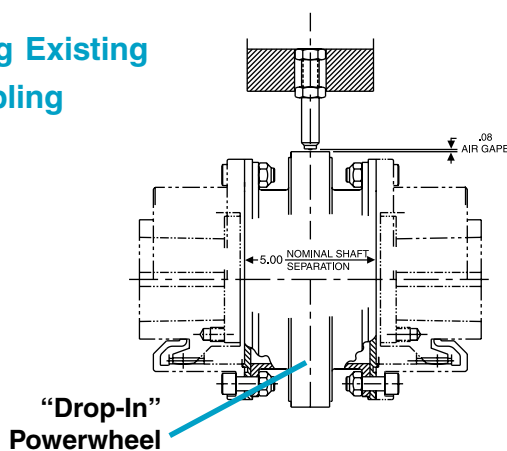

Retrofitting: Until now, retrofitting turbomachinery equipment with torque meter systems was almost impossible. The modular Powerwheel Performance Torque Monitoring System solves this problem. A shorter replacement coupling, or existing coupling spacer, are designed to meet the torque and speed requirements, retrofit criteria and envelope dimensions of the existing application. The modular wheel is a drop-in component of the high-speed coupling. In most cases, the existing guard can be utilized, eliminating the high cost of designing and manufacturing a new guard. The monopole sensors are easily installed by cutting two, 4.5" diameter holes at 180 degrees.

Powerwheel can be retrofitted in any coupling, regardless of the manufacturer. Every effort is made to match the mass elastic data of the coupling to ensure reliable, trouble-free operation. Powerwheel also offers designers the ability to move the wheel to a more suitable location when lateral critical speed is a concern.

Options:

- Windows-PC compatible data storage and graphics package for trend analysis
- Field service technicians for installation supervision and training
- Cross site cables
- Integration with DCS
- Wireless transmission



Worldwide Service & Support

Kop-Flex consistently responds to customer needs for reliable, safe, maintenance-friendly products by demonstrating an attention to detail that is highly valued in the marketplace. Kop-Flex also has the market's largest stock of critical couplings for overnight delivery to support a company-wide priority on helping customers maintain uptime.

Kop-Flex offers extensive service and repair capabilities in Baltimore, Rexdale, Ontario, Canada and our latest coupling plant in Slovakia. All locations are ISO 9000 certified. Additional licensed repair facilities are located within partners' locations in Indiana, Alabama, Texas and California. With manufacturing and service facilities in the U.S. and now in Europe, Kop-Flex can service customers throughout the world.

All Kop-Flex facilities are state-of-the-art, with access to a large and experienced engineering staff. A dedicated service center team, including expert engineers, customer service representatives and repair coordinators, assist in field installation and troubleshooting to manage all your coupling maintenance needs – regardless of the type or the manufacturer.

Kop-Flex practices an extensive inspection process and can repair or refurbish any coupling – including designs produced by other manufacturers. Customer risk is further reduced with the full Kop-Flex warranty.

iCAP—Helpful Online Tools

Kop-Flex created a unique online design tool, called iCAP, that designs couplings per API/ISO or customer specifications. The tool also generates mass elastic data and creates CAD drawings, including a bill of materials. This helps you confirm that a proposed coupling solution will meet stated requirements and rotor dynamics. The resulting design is viewable online and can be downloaded in various formats. For more information, visit www.kopflex.com/product-selection or contact a Kop-Flex representative in your area.

Now Available from Kop-Flex Hydraulic Removal and Installation Kits for Keyed and Keyless Hubs

Why do you need this kit?

- The use of heat in hub installation and removal is cumbersome
- Time-consuming and sometimes restricted by specific safety codes
- The risk of damaging the coupling parts by overheating is eliminated
- The potential of scoring the bore or the shaft is minimized due to the inherent lubrication of the surfaces in contact
- Maintenance work is simplified. Hydraulic kit is packaged in a durable tool box for safe storage

System Capabilities

- Designs for any combination of hub to shaft connections; tapered or straight, single or doubled - keyed
- Max interference rate; 0.0012"
- New applications or retrofits of existing hubs
- No shaft size limitation
- Repeated installation or removal sequences without damage of the contact surfaces
- Standardization of components for minimum inventory
- Low cost hydraulics, 10,000 psi rating

Technical Assistance

- Detailed operation instructions are furnished upon delivery.
- Demonstration can be arranged in our facilities.
- Training sessions for maintenance personnel.
- On site assistance by Kop-Flex service engineers.

(Contact Kop-Flex for service rate schedule)

A typical kit consists of high and low pressure pumps, gauges, and hoses with pusher/cylinder assembly and puller (see photo below).

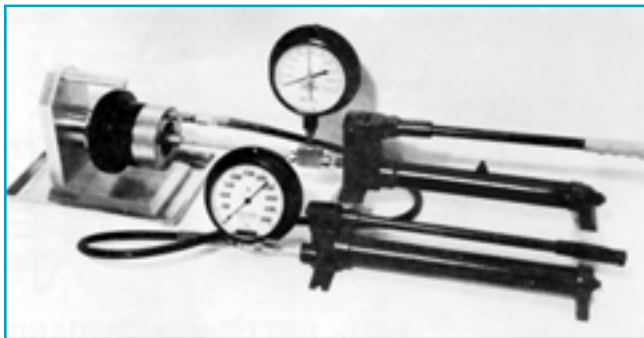

Kop-Flex Can Also Offer:

- On-site, expert Kop-Flex service engineers for coupling installation
- Matched sets of plug and ring gauges manufactured from heat-treated alloy steel
- Moment simulators - distance from end of the shaft to the outboard bearing is needed and moment simulators are also used as an adapter plate
- Adapter/Solo plates available for a flex half coupling to allow uncoupled operation of equipment
- Drill templates - when a coupling is used with integral flanged shaft end, a drill template may be required and Kop-Flex can supply a one-time use template or multi-use template
- Two-piece stop rings can be provided to limit and set the advance of the hydraulically fitted coupling hubs during installation

Plug and Ring Gauges

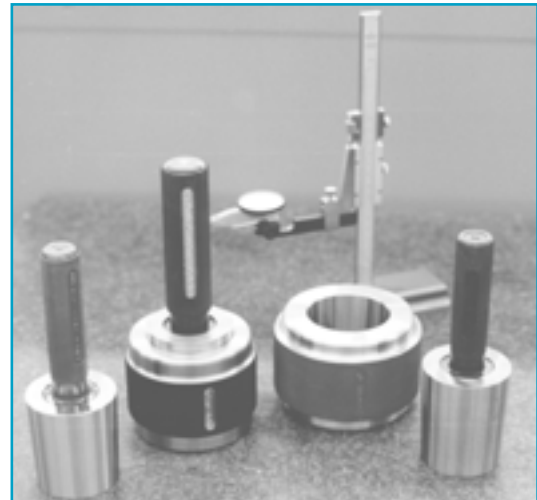

Other Options Available

- Speed pick-up teeth
- Turning gear teeth
- Coupling coatings
- Electrically insulated
- Laterally tuned coupling
- Torsional tuned coupling
- Key phasor slot
- Labyrinth seal
- Seal surface
- Overload protection
- Shear spacer section
- Shear pin cartridges
- Special balancing
- Special markings
- Long spacers
- Axial probe reading surfaces
- Alignment tool surfaces
- Shaft flange mounting



As the world's leading manufacturer of flexible shaft couplings, Kop-Flex was one of the first companies to develop greases especially for use as shaft coupling lubricants. Kop-Flex recognized that couplings must use greases with certain special qualities, and as the company most likely to understand these very special needs, Kop-Flex knew that most commercial grease formulations will not ensure adequate performance and are not ideal coupling lubricants.

Coupling grease, unlike bearing or general purpose grease, must withstand the centrifugal forces created by a rotating coupling. Coupling greases from Kop-Flex are specifically formulated to resist the high centrifugal forces associated with all applications, including slow motor speeds. These forces can cause the all-important base oil to separate from the soap thickeners and additives. Unlike greases with lithium-based thickeners, KHP and KSG greases use polyethylene thickeners, with a density closer to that of oil, and are therefore much less susceptible to separation. Heavier thickeners and additives can separate and migrate into the gear teeth or other working parts, displacing the lubricating oils from where they are most needed.

All of our greases are lead free.

Container	Unit Wt	No. of Units	KSG Grease	KHP Grease	Waverly* Lube "A"			
			Part No.	Part No.	Container	Unit Wt	No. of Units	Part No.
Grease Gun Cartridge	14 oz.	1	KSG 14OZ	KHP 14OZ	Pail	40 lb.	1	WAVERLY* LUBE A 40LB PAIL
Grease Gun Cart., Case	14 oz.	25	KSG 14OZ CASE	KHP 14OZ CASE	Keg	120 lb.	1	WAVERLY* LUBE A 120LB KEG
1 lb Can	1 lb.	1	KSG 1LB	KHP 1LB	Drum	400 lb.	1	WAVERLY* LUBE A 400LB DRUM
1 lb Can, Case	1 lb.	24	KSG 1LB CASE	KHP 1LB CASE				
5 lb Can	5 lb.	1	KSG 5LB	KHP 5LB				
5 lb Can, Case	5 lb.	6	KSG 5LB CASE	KHP 5LB CASE				
Pail	35 lb.	1	KSG 35LB	KHP 35LB				
Keg	120 lb.	1	KSG 120LB	KHP 120LB				
Drum	395 lb.	1	KSG 395LB	KHP 395LB				

Waverly* Torque Lube 'A' is available in 40-pound, 120-pound, and 400-pound containers and in bulk tank trailer loads of 12,000-pound minimum. Contact Kop-Flex to order.

Selection Guide to Coupling Greases

- KSG is excellent for standard and routinely serviced couplings operating at normal motor speeds.
- KHP has both exceptional lubricating and high operating temperature properties. As a general rule, if the coupling is balanced or if very long periods of operation are desired, use KHP.
- Waverly* Torque Lube 'A' is a special purpose grease for relatively slow speed, highly loaded mill spindle couplings. It is not intended for use in other types of couplings.

Notice to Users

All of our grease is manufactured for Kop-Flex couplings and are for industrial use only. These products should not be ingested and should be properly stored and kept away from children. Read all container labeling and any precautionary statements. Material Safety Data Sheets are available upon request. Use absorbent material to clean up any spill and dispose of the waste in accordance with state and local regulations.

No warranties, expressed or implied, including patent warranties, warranties of merchantability, fitness for use, are made by Kop-Flex, Inc. with respect to products described on information set forth herein. Nothing contained herein shall constitute a permission or recommendation to practice any invention covered by a patent without a license from the owner of the patent.

KSG Standard Coupling Grease

KSG is an NLGI Grade #1 coupling grease with E.P. additives for use in any grease-packed coupling, such as gear, grid and chain-type couplings, in standard industrial service. Superior to the commonly available greases adapted to coupling use, KSG was developed specifically as a coupling lubricant.

KHP High Performance Coupling Grease

KHP grease is an NLGI #1 grease with E. P. additives, which exceeds the design requirements needed for extended operating and relubrication intervals. KHP grease is recommended for high-speed, grease lubricated, gear couplings in petrochemical, process and utility industries.

Waverly* Torque Lube 'A' Gear Spindle Grease

Torque Lube 'A' was developed to solve the special lubrication problems of relatively low speed, highly loaded, gear spindle couplings used extensively in metal rolling mills. Torque Lube 'A' has consistently provided protection in applications demanding a lubricant with extreme pressure protection, high heat and shock loading, excellent wear protection and resistance to water washout. This grease is compounded with a concentration of Molybdenum Disulfide and other additives to provide extreme pressure protection. These additives cannot resist the effects of centrifugal forces; therefore, Waverly* Torque Lube 'A' should not be used in a standard coupling without consulting Kop-Flex.

*Waverly Torque Lube 'A', is a trademark and/or a trade name of Exxon Corporation & Witco Corporation, Bakerstown, PA.

This trade name, trademark and/or registered trademark is used herein for product comparison purposes only, is the property of its respective owner and is not owned or controlled by Emerson Power Transmission Corporation. Emerson Power Transmission does not represent or warrant the accuracy of this document.

KD series of flexible shaft couplings provides reliable transmission of mechanical power from driving to driven machine where a low-maintenance, non-lubricated coupling is required.

KD disc couplings are specifically designed to accommodate general purpose, drive system applications such as centrifugal pumps, compressors, generators, cooling towers, machine tools, printing and pulp and paper machines.

KD couplings transmit torque and provide for both angular and axial misalignment between shafts with a coupling comprised of shaft mounted hubs connected through flexible disc packs with spacer or sleeve assemblies.

All KD couplings use stainless steel discs as flexible members, providing high strength and good corrosion resistance. The streamlined, disk pack design minimizes reaction load on the equipment bearings. These disc pack couplings are inherently self-centering; additional provision for limited end float is not required.

Most disc packs are unitized and, along with self-locking nuts, they greatly reduce the number of loose parts, thus simplifying installation and replacement.

KD disc couplings are now available in an expanded range of sizes and styles suitable for common installations. Or if you need something special, we can design a coupling to meet your specific requirements.



KD

Disc Couplings Size 103 through 905

Non-Lubricated for
Simplified Maintenance

Higher Torque Ratings,
Similar to
Gear Couplings

Excellent Balance
Characteristics

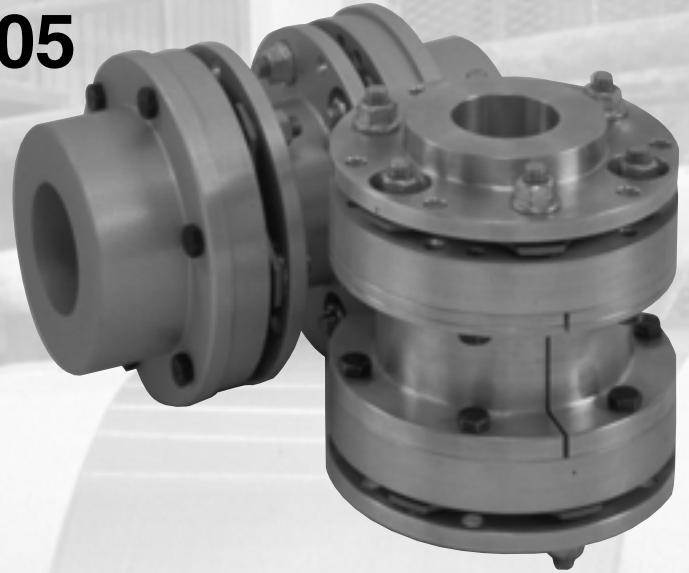

Index:

	Page
Selection Procedure	90
Disc Pack Descriptions	90
Service Factors	92
Dynamic Balancing Guide	93
KD1 Close Coupled	94, 95
KD10 Close Coupled	96, 97
KD11 Close Coupled	98, 99
KD2 Spacer Coupling	100, 101
KD20 Spacer Coupling	102, 103
KD21 Spacer Coupling	104, 105
KD22 Spacer Coupling	106, 107
KD33 Cooling Tower Coupling	108

Disc Pack Data

Selection Procedure

1. Coupling style:

Select the appropriate KD coupling style for your application from the Product Overview & Index.

2. Coupling size:

Step 1: Determine the proper service factor from page 92.

Step 2: Calculate the required HP/100 RPM, using the HP rating of the drive and the coupling speed (RPM) as shown below:

$$\frac{\text{HP} \times \text{SERVICE FACTOR} \times 100}{\text{RPM}} = \text{HP/100 RPM}$$

Step 3: Select the coupling size having a rating sufficient to handle the required HP/100 RPM at the appropriate service factor.

Step 4: Verify that the maximum bore of the coupling selected is equal to or larger than either of the equipment shafts.

Step 5: Check the overall dimensions to ensure the coupling will not interfere with the coupling guard, piping, or the equipment housings and that it will fit the required shaft separation.

3. Check balance requirements.

Consult the Dynamic Balancing Guide on page 93 to help determine if balancing is required. Verify that the maximum operating speed does not exceed the maximum speed rating of the coupling.

The maximum speed rating does not consider lateral, critical speed considerations for floating shaft applications.

4. Specify shaft separation.

Specify the required shaft separation using standard length, if possible. Verify the actual shaft separation for a replacement application.

Note: Care must be exercised in proper selection of any shaft coupling. The users must assure themselves that the design of the shaft to coupling hub connection is adequate for the duty intended.



MT disc pack	[Medium Torque] unitized, 3 bolt disc with “prestretch” bushings that get pressed into the flanges, uses standard fasteners. KD1, 2
HT disc pack	[High Torque] unitized, 3, 4 or 5 bolt discs, thicker for high torque, body fit bolts. KD11, 20, 21, 22, 4, 41, 42
HS disc pack	[High Torque - Semi-unitized] same as HT but <u>semi-unitized</u> so that the disc packs may be installed out between close-coupled hubs. KD10
CT disc pack	[Cooling Tower] unitized, 3 bolt disc for cooling tower couplings, stainless steel components with body-fit bolts. KD33
HM disc pack	[High Torque - Marine] same as HT but <u>with coated discs</u> , for marine applications - DNV approved.
LT disc pack	[Low Torque - Light Duty] non-unitized, most economical, body fit bolts. KD5, 50, 51



Close Coupled

KD1 with MT Disc Packs

Size Range 103 to 453
Bore Range .50 - 5.50"
Overview Unitized disc pack replaced without moving connected machines
 Medium duty applications

Page
94, 95

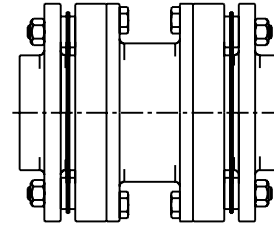

KD1 and KD10

KD10 with HS Disc Packs

Size Range 103 to 905
Bore Range .50 - 11.50"
Overview Unitized disc pack replaced without moving connected machines
 Heavy duty applications
 Ratings similar to gear couplings

96, 97

KD11 with HT Disc Packs

Size Range 103 to 905
Bore Range .50 - 11.50"
Overview Unitized disc pack
 Heavy duty applications
 Ratings similar to gear couplings

98, 99

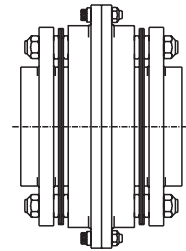

KD11

Spacer Styles

KD2 with MT Disc Packs

Size Range 023 to 453
Bore Range .50 - 7.25"
Overview "Drop-out" spacer design
 Factory assembled center flex section
 Medium duty applications

100, 101

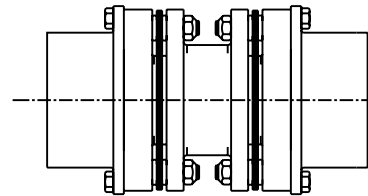

KD2 and KD20

KD20 with HT Disc Packs

Size Range 204 to 905
Bore Range 1.00 - 13.50"
Overview "Drop-out" spacer design
 Factory assembled center flex section
 High torque applications

102, 103

KD21 with HT Disc Packs

Size Range 053 to 905
Bore Range .50 - 13.50"
Overview Simple 3-piece spacer design
 Unitized "drop-out" disc pack
 High torque applications

104, 105

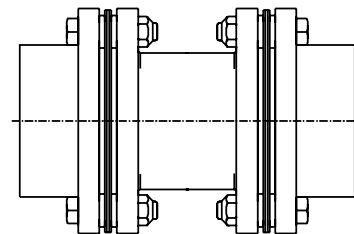

KD21

Cooling Tower Page

KD33 with CT Disc Packs

Size Range 153 to 303
Bore Range .50 - 4.50"
Overview Cooling towers with very long shaft separation
 Stainless steel/composite tubes
 Replaces most competitive cooling tower couplings
 Non-lubricated

108

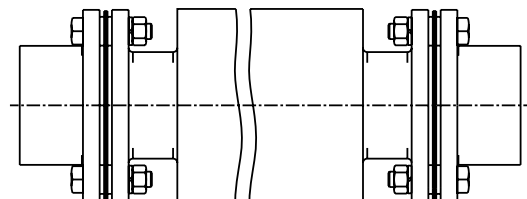

KD33

Values listed are intended only as a general guide, and are typical of usual service requirements. For systems that frequently utilize the peak torque capability of the power source, verify that the magnitude of this peak torque does not exceed the 1.0 service factor rating of the coupling selected. Applications that involve extreme repetitive shock or high-energy load absorption characteristics should be referred — with full particulars — to Kop-Flex.

Values contained in the table are to be applied to smooth power sources such as electric motors and steam turbines. For drives involving internal combustion engines of four or five cylinders, add 1.0 to the values listed; for six or more cylinders, add 0.5 to the values listed. For systems utilizing AC or DC mill motors as the prime mover, refer to Note (1).

CAUTION All people-moving applications must be referred to engineering.

Application	Typical Service Factor
AGITATORS	
Pure Liquids	1.0
Liquids & Solids	1.25
Liquids — Variable Density	1.25
BLOWERS	
Centrifugal	1.0
Lobe	1.5
Vane	1.25
BRIQUETTE MACHINES	2.0
CAR PULLERS — Intermittent Duty	1.5
COMPRESSORS	
Centrifugal	1.0
Centriaxial	1.25
Lobe	1.5
Reciprocating — Multi-Cylinder	2.0
CONVEYORS — LIGHT DUTY UNIFORMLY FED	
Apron, Bucket, Chain, Flight, Screw	1.25
Assembly, Belt	1.0
Oven	1.5
CONVEYORS — HEAVY DUTY NOT UNIFORMLY FED	
Apron, Bucket, Chain, Flight, Oven	1.5
Assembly, Belt	1.25
Reciprocating, Shaker	2.5
CRANES AND HOISTS (NOTE 1 and 2)	
Main hoists, Reversing	2.5
Skip Hoists, Trolley & Bridge Drives	2.0
Slope	2.0
CRUSHERS	
Ore, Stone	3.0
DREDGES	
Cable Reels	1.75
Conveyors	1.5
Cutter Head Jig Drives	2.5
Maneuvering Winches	1.75
Pumps	1.75
Screen Drives	1.75
Stackers	1.75
Utility Winches	1.5
ELEVATORS (NOTE 2)	
Bucket	1.75
Centrifugal & Gravity Discharge	1.5
Escalators	1.5
Freight	2.5
FANS	
Centrifugal	1.0
Cooling Towers	1.5
Forced Draft	1.5
Induced Draft without Damper Control	2.0
FEEDERS	
Apron, Belt, Disc, Screw	1.25
Reciprocating	2.5

Application	Typical Service Factor
GENERATORS — (Not Welding)	1.0
HAMMER MILLS	2.0
LAUNDRY WASHERS — Reversing	2.0
LAUNDRY TUMBLERS	2.0
LINE SHAFT	1.5
LUMBER INDUSTRY	
Barkers — Drum Type	2.0
Edger Feed	2.0
Live Rolls	2.0
Log Haul — Incline	2.0
Log Haul — Well type	2.0
Off Bearing Rolls	2.0
Planer Feed Chains	1.75
Planer Floor Chains	1.75
Planer Tilting Hoist	1.75
Slab Conveyor	1.5
Sorting Table	1.5
Trimmer Feed	1.75
MARINE PROPULSION	
Main Drives	2.0
MACHINE TOOLS	
Bending Roll	2.0
Plate Planer	1.5
Punch Press — Gear Driven	2.0
Tapping Machines	2.5
Other Machine Tools	
Main Drives	1.5
Auxiliary Drives	1.25
METAL MILLS	
Draw Bench — Carriage	2.0
Draw Bench — Main Drive	2.0
Forming Machines	2.0
Slitters	1.5
Table Conveyors	
Non-Reversing	2.25
Reversing	2.5
Wire Drawing & Flattening Machine	2.0
Wire Winding Machine	1.75
METAL ROLLING MILLS (NOTE 1)	
Blooming Mills	*
Coilers, hot mill	2.0
Coilers, cold mill	1.25
Cold Mills	2.0
Cooling Beds	1.75
Door Openers	2.0
Draw Benches	2.0
Edger Drives	1.75
Feed Rolls, Reversing Mills	3.5
Furnace Pushers	2.5
Hot Mills	3.0
Ingot Cars	2.5
Kick-outs	2.5
Manipulators	3.0
Merchant Mills	3.0
Piercers	3.0
Pusher Rams	2.5
Reel Drives	1.75
Reel Drums	2.0
Reelers	3.0
Rod and Bar Mills	1.5
Roughing Mill Delivery Table	3.0
Runout Tables	
Reversing	3.0
Non-Reversing	2.0
Saws, hot & cold	2.5
Screwdown Drives	3.0
Skelp Mills	3.0
Slitters	3.0
Slabbing Mills	3.0
Soaking Pit Cover Drives	3.0
Straighteners	2.5
Tables, transfer & runout	2.0
Thrust Block	3.0
Traction Drive	3.0
Tube Conveyor Rolls	2.5
Unscramblers	2.5
Wire Drawing	1.5
MILLS, ROTARY TYPE	
Ball	2.25
Dryers & Coolers	2.0
Hammer	1.75
Kilns	2.0

Application	Typical Service Factor
Pebble & Rod	2.0
Pug	1.75
Tumbling Barrels	2.0
MIXERS	
Concrete Mixers	1.75
Drum Type	1.5
OIL INDUSTRY	
Chillers	1.25
Paraffin Filter Press	1.75
PAPER MILLS	
Barker Auxiliaries, Hydraulic	2.0
Barker, Mechanical	2.0
Barking Drum Spur Gear Only	2.25
Beater & Pulper	1.75
Bleacher	1.0
Calenders	2.0
Chippers	2.5
Coaters	1.0
Converting Machines, except Cutters, Platers	1.5
Couch Roll	1.75
Cutters, Platers	2.0
Cylinders	1.75
Disc Refiners	1.75
Dryers	1.75
Felt Stretcher	1.25
Felt Whipper	2.0
Jordans	1.75
Line Shaft	1.5
Log Haul	2.0
Pulp Grinder	1.75
Press Roll	2.0
Reel	1.5
Stock Chests	1.5
Suction Roll	1.75
Washers & Thickeners	1.5
Winders	1.5
PRINTING PRESSES	1.5
PULLERS — Barge Haul	2.0
PUMPS	
Centrifugal	1.0
Boiler Feed	1.5
Reciprocating	
Single Acting	
1 or 2 Cylinders	2.25
3 or more Cylinders	1.75
Double Acting	2.0
Rotary, Gear, Lobe, Vane	1.5
RUBBER INDUSTRY	
Mixer — Banbury	2.5
Rubber Calendar	2.0
Rubber Mill (2 or more)	2.25
Sheeter	2.0
Tire Building Machines	2.5
Tire & Tube Press Openers	1.0
Tubers & Strainers	2.0
SCREENS	
Air Washing	1.0
Grizzly	2.0
Rotary — Stone or Gravel	1.5
Traveling Water Intake	1.25
Vibrating	2.5
SEWAGE DISPOSAL EQUIPMENT	
Bar Screens	1.25
Chemical Feeders	1.25
Collectors, Circuline or Straightline	1.25
Dewatering Screens	1.25
Grit Collectors	1.25
Scum Breakers	1.25
Slow or Rapid Mixers	1.25
Sludge Collectors	1.25
Thickeners	1.25
Vacuum Filters	1.25
STEERING GEAR	1.0
STOKERS	1.0
WINCH	1.5
WINDLASS	1.75

* Refer to Kop-Flex

NOTES

- (1) Maximum Torque at the coupling must not exceed Rated Torque of the coupling.
- (2) Check local and industrial safety codes.

Balancing requirements for a coupling are dependent on factors determined by the characteristics of the connected equipment. For this reason, the balancing charts should be used as a guide only to assist in determining whether or not balancing is required.

The balancing charts shown are based on AGMA 9000-C90 suggested balance classes for systems with “average” sensitivity to unbalance. For systems with higher sensitivity to unbalance, balancing of the coupling may be required at lower speeds. For systems that are less sensitive to unbalance, couplings may be able to operate at higher speeds than those shown at lower balance levels. Therefore, in the absence of either a thorough system analysis or past user experience with a similar installation, these charts should be used as a guide only.

KD couplings are available in several styles to meet the balance requirements of API 610, including the 8th Edition. Consult Kop-Flex for details.

KD1 and KD10 couplings meet AGMA Class 8 balance levels as-manufactured (off-the-shelf) and may be component balanced to run at higher speeds. Refer to the ratings table for the maximum operating speeds for non-balanced and balanced couplings.

KD11 couplings are designed for higher speeds and meet AGMA Class 9 balance as-manufactured. KD11 couplings may be component balanced to meet Class 10 balance, and may be assembly balanced to Class 11.

KD2, KD20, and KD21 couplings meet AGMA Class 9 balance levels as manufactured and may be component balanced to meet Class 10 balance. KD2 and KD20 couplings may be assembly balanced to meet AGMA Class 11 balance. KD21 couplings are not assembly balanced. Refer to the charts on this page for balancing recommendations.

Balancing of sizes larger than 604 must be considered on a case-by-case basis. Consult Kop-Flex for assistance.

For KD4, KD41 and KD42, and KD22 couplings, balance considerations should be reviewed on a case-by-case basis. Consult engineering for assistance. KD5, 50 and 51 couplings are not balanced.

KD21 Balancing Chart for up to 457 mm Shaft Separation

Based on AGMA 9000-C90 for Average System Sensitivity

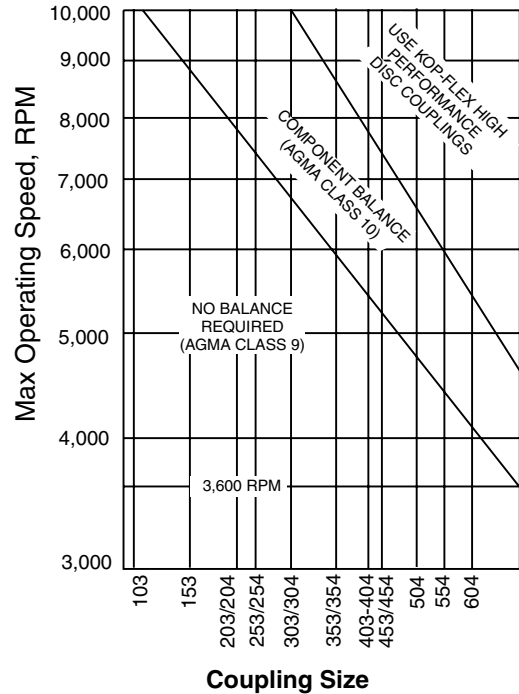

KD2 & KD20 Balancing Chart for up to 457 mm Shaft Separation

Based on AGMA 9000-C90 for Average System Sensitivity

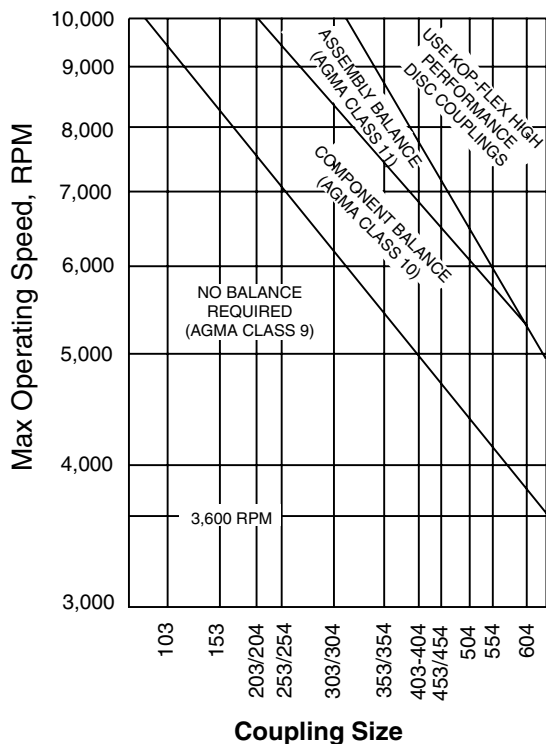

KD11 Balancing Chart

Based on AGMA 9000-C90 for Average System Sensitivity

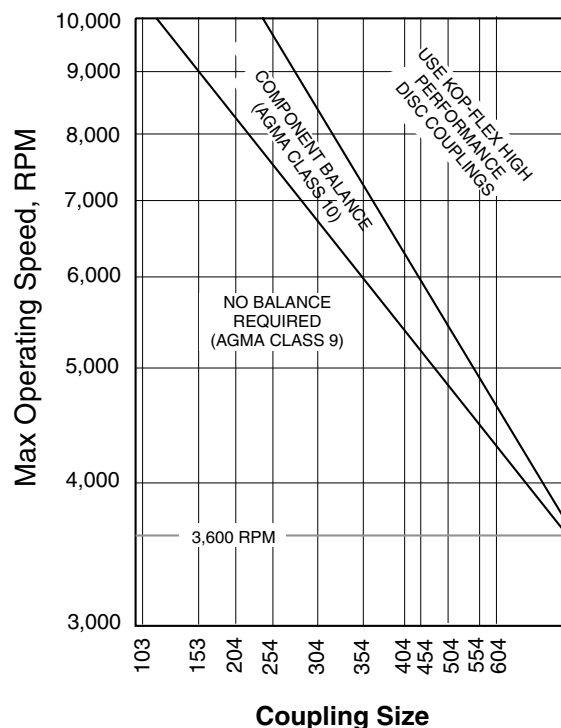

The KD1 coupling is designed for close coupled applications with minimal to short distance between shaft ends and light to medium loading. It can directly replace most Rex/Thomas* DBZ couplings and the unitized disc pack design makes the installation simpler and easier.

The KD1 is comprised of two hubs, two rings, two disc packs and a piloted split spacer. The standard coupling hubs may be installed in any of three mounting positions for design and installation flexibility. The split spacer pilot gives the KD1 coupling improved dynamic balance characteristics and contains a design feature to hold the split spacer in place while the coupling is rotating.

KD1 disc packs are unitized to greatly reduce the number of loose parts. The split spacer simply drops away from the hubs for faster installation and replacement without moving connected machinery. The standard coupling balance meets AGMA Class 8 as manufactured, dynamic balance to AGMA Class 9 and conformance to API 610 are available options.

For higher power requirements, consider a KD10 disc coupling. For higher speeds, consider a KD11 disc coupling.



- Medium duty
- Minimal to short shaft separations
- Split spacer with safety pilot
- Replacement for Rex/Thomas* DBZ
- Drop-out, unitized disc packs

KD1 couplings use MT disc packs.

Complete Couplings

Coupling Size	Complete Coupling with 2 Std. Hubs		Complete Coupling with 1 Std. Hub and 1 Long Hub		Complete Coupling with 2 Long Hubs	
	Rough Bore	Finish Bore ^①	Rough Bore	Finish Bore ^①	Rough Bore	Finish Bore ^①
103	103 KD 1 SS	103 KD 1 SS FB	103 KD 1 SL	103 KD 1 SL FB	103 KD 1 LL	103 KD 1 LL FB
153	153 KD 1 SS	153 KD 1 SS FB	153 KD 1 SL	153 KD 1 SL FB	153 KD 1 LL	153 KD 1 LL FB
203	203 KD 1 SS	203 KD 1 SS FB	203 KD 1 SL	203 KD 1 SL FB	203 KD 1 LL	203 KD 1 LL FB
253	253 KD 1 SS	253 KD 1 SS FB	253 KD 1 SL	253 KD 1 SL FB	253 KD 1 LL	253 KD 1 LL FB
303	303 KD 1 SS	303 KD 1 SS FB	303 KD 1 SL	303 KD 1 SL FB	303 KD 1 LL	303 KD 1 LL FB
353	353 KD 1 SS	353 KD 1 SS FB	353 KD 1 SL	353 KD 1 SL FB	353 KD 1 LL	353 KD 1 LL FB
403	403 KD 1 SS	403 KD 1 SS FB	403 KD 1 SL	403 KD 1 SL FB	403 KD 1 LL	403 KD 1 LL FB
453	453 KD 1 SS	453 KD 1 SS FB	453 KD 1 SL	453 KD 1 SL FB	453 KD 1 LL	453 KD 1 LL FB

^① All finish bores and keyways per AGMA 9002-A86 commercial standard tolerances.

Component Parts

Description	Part Number
Standard Hub	SHUB
Long Hub	LHUB
*Center Assembly	CA
**MT Disc Pack Assembly	MTDP
**MT Disc Pack Fastener Set	MTFS
**Flange Fastener Set	FFSMT

* Center assembly includes (2) disc packs, (2) disc pack fastener sets.

** For disc packs and fastener sets, do not include "series" number in the part number.

How to Order Components

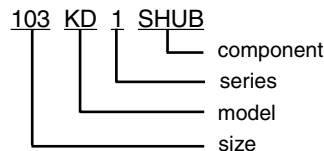

How to Order Disc Packs and Fastener Sets

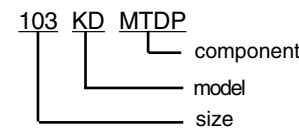

*Rex/Thomas is a trademark and/or a trade name of Rexnord Industries Inc.

This trade name, trademark and/or registered trademark is used herein for product comparison purposes only, is the property of its respective owner and is not owned or controlled by Emerson Power Transmission Corporation. Emerson Power Transmission does not represent or warrant the accuracy of this document.

Selection Data

Size	Max. Bore (in)	Coupling Rating (HP/100 RPM)	Torque Rating		Maximum Speed Not Balanced (RPM)	Maximum Speed Balanced (RPM)	Total ^① Weight (lbs)	Total ^① WR ² (lb-in ²)	Axial Capacity (in)
			Continuous (in-lb)	Peak (in-lb)					
103	1.62	4.3	2710	5420	5400	9700	8.1	18.6	±.060
153	2.25	12.5	7880	15760	4500	7500	19.8	83.9	±.075
203	2.75	22.9	14400	28800	4100	6700	31.9	184	±.090
253	3.25	37.5	23600	47200	3600	5600	51.6	417	±.105
303	3.88	60.0	37800	75600	3200	5100	77.3	856	±.125
353	4.38	100	63000	126000	2900	4400	129	1940	±.150
403	5.00	155	97700	195000	2600	4000	189	3720	±.175
453	5.50	205	129000	258000	2400	3800	223	5170	±.200

① Data based on maximum bores.

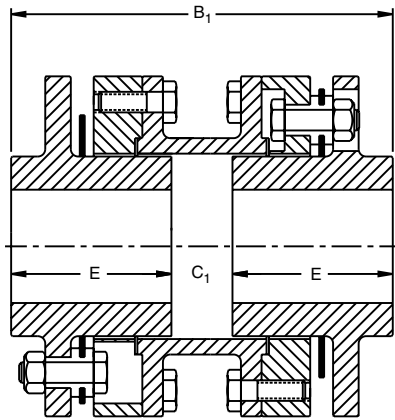

STANDARD HUBS

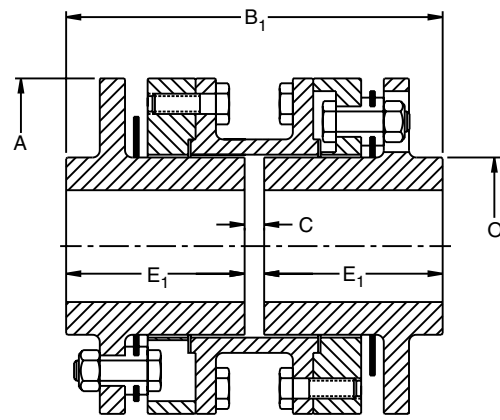

LONG HUBS

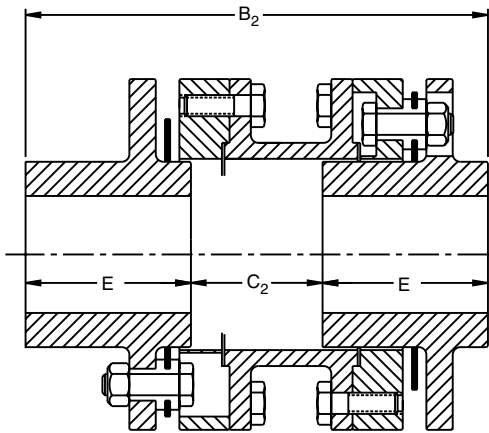

ONE HUB REVERSED

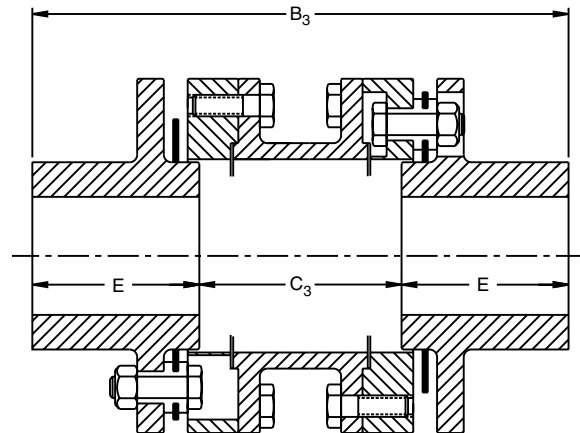

TWO HUBS REVERSED

Dimensional Data

Size	Rough Bore	A (in)	B ₁ (in)	B ₂ (in)	B ₃ (in)	C (in)	C ₁ (in)	C ₂ (in)	C ₃ (in)	E (in)	E ₁ (in)	O (in)
103	.50	4.12	4.94	5.69	6.44	.12	.94	1.69	2.44	2.00	2.41	2.19
153	.50	5.50	6.44	7.75	9.06	.12	1.19	2.50	3.81	2.62	3.16	3.00
203	.75	6.50	7.31	8.81	10.31	.19	1.31	2.81	4.31	3.00	3.56	3.75
253	1.00	7.75	8.38	10.06	11.75	.19	1.50	3.19	4.88	3.44	4.09	4.50
303	1.00	9.00	9.88	11.94	14.00	.25	1.75	3.81	5.88	4.06	4.81	5.25
353	1.00	10.50	11.19	13.56	15.94	.25	1.94	4.31	6.69	4.62	5.47	6.00
403	1.00	12.00	12.62	15.19	17.75	.31	2.12	4.69	7.25	5.25	6.16	6.75
453	1.50	13.00	13.12	15.69	18.25	.31	2.12	4.69	7.25	5.50	6.41	7.50

The KD10 coupling is designed to work in place of standard, close coupled gear coupling applications with minimal distance between shaft ends. The power capacity of the KD10 coupling is the highest in the industry, allowing the easiest conversion from a lubricated coupling to a low maintenance disc coupling.

The KD10 is comprised of two hubs, two rings, two disc packs and a piloted split spacer. The standard coupling hubs may be installed in two mounting positions for design and installation flexibility. The split spacer pilot gives the KD10 coupling improved dynamic balance characteristics and contains a design feature to hold the split spacer in place while the coupling is rotating.

KD10 disc packs are semi-unitized to greatly reduce the number of loose parts. The split spacer simply drops away from the hubs for faster installation and replacement of the disc packs without moving connected machinery. The standard coupling balance meets AGMA Class 8 as manufactured, dynamic balance to AGMA Class 9 and conformance to API 610 are available options.

For higher speed requirements, consider a KD11 disc coupling.

KD10 couplings use HS semi-unitized disc packs, for easy replacement without moving connected equipment.



- Heavy duty, highest power capacity
- Minimal shaft separations
- Split spacer with safety pilot
- Replacement for standard gear couplings
- Drop-out, semi-unitized disc packs

Complete Couplings

Coupling Size	Complete Coupling with 2 Std. Hubs	
	Rough Bore	Finish Bore ^①
103	103 KD 10 SS	103 KD 10 SS FB
153	153 KD 10 SS	153 KD 10 SS FB
204	204 KD 10 SS	204 KD 10 SS FB
254	254 KD 10 SS	254 KD 10 SS FB
304	304 KD 10 SS	304 KD 10 SS FB
354	354 KD 10 SS	354 KD 10 SS FB
404	404 KD 10 SS	404 KD 10 SS FB
454	454 KD 10 SS	454 KD 10 SS FB
504	504 KD 10 SS	504 KD 10 SS FB
554	554 KD 10 SS	554 KD 10 SS FB
604	604 KD 10 SS	604 KD 10 SS FB
705	705 KD 10 SS	705 KD 10 SS FB
805	805 KD 10 SS	805 KD 10 SS FB
905	905 KD 10 SS	905 KD 10 SS FB

^① All finish bores and keyways per AGMA 9002-A86 commercial standard tolerances.

Component Parts

Description	Part Number
Standard Hub	SHUB
*Center Assembly	CA
**HS Disc Pack Assembly	HSDP
**HS Disc Pack Fastener Set	HSFS
**Flange Fastener Set	FFSHT

* Center assembly includes (2) disc packs, (2) disc pack fastener sets.
 ** For disc packs and fastener sets, do not include "series" number in the part number.

Note: Complete couplings are supplied with HT disc packs (HTDP) for ease of initial installation. HS disc packs (HSDP) should be used for replacement without moving connected equipment.

How to Order Components

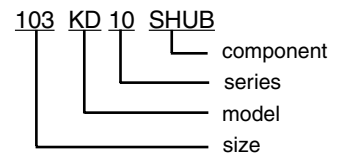

How to Order Disc Packs & Fastener Sets

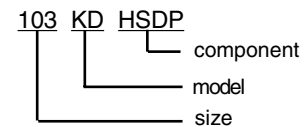

Visit www.kopflex.com

Selection Data

Size	Max. Bore (in)	Coupling Rating (HP/100 RPM)	Torque Rating		Max. Speed Not Balanced (RPM)	Maximum Speed Balanced (RPM)	Total ^① Weight (lbs)	Total ^① WR ² (lb-in ²)	Axial Capacity (in)
			Continuous (in-lb)	Peak (in-lb)					
103	1.50	6.3	4000	8000	5400	9700	6.9	16	±.080
153	2.12	21.6	13600	27200	4500	7500	17.5	73	±.140
204	2.62	57.1	36000	72000	4100	6700	27.2	148	±.110
254	3.25	82.5	52000	104000	3600	5600	47.2	400	±.140
304	3.75	141	89000	178000	3200	5100	78.0	916	±.170
354	4.25	238	145000	290000	2900	4400	134	2140	±.200
404	4.75	340	215000	430000	2600	4000	193	3850	±.225
454	5.50	405	255000	510000	2400	3800	229	5540	±.250
504	5.75	570	360000	720000	2200	3500	316	8640	±.275
554	6.25	800	505000	1010000	1900	3000	404	13100	±.300
604	6.75	1050	660000	1320000	1850	2900	559	22200	±.320
705	8.50	2400	1510000	3020000	1800	2800	925	56400	±.270
805	9.50	3670	2100000	4200000	1600	2500	1340	102000	±.310
905	11.50	4130	2300000	4600000	1500	2300	1700	163000	±.400

① Data based on maximum bores.

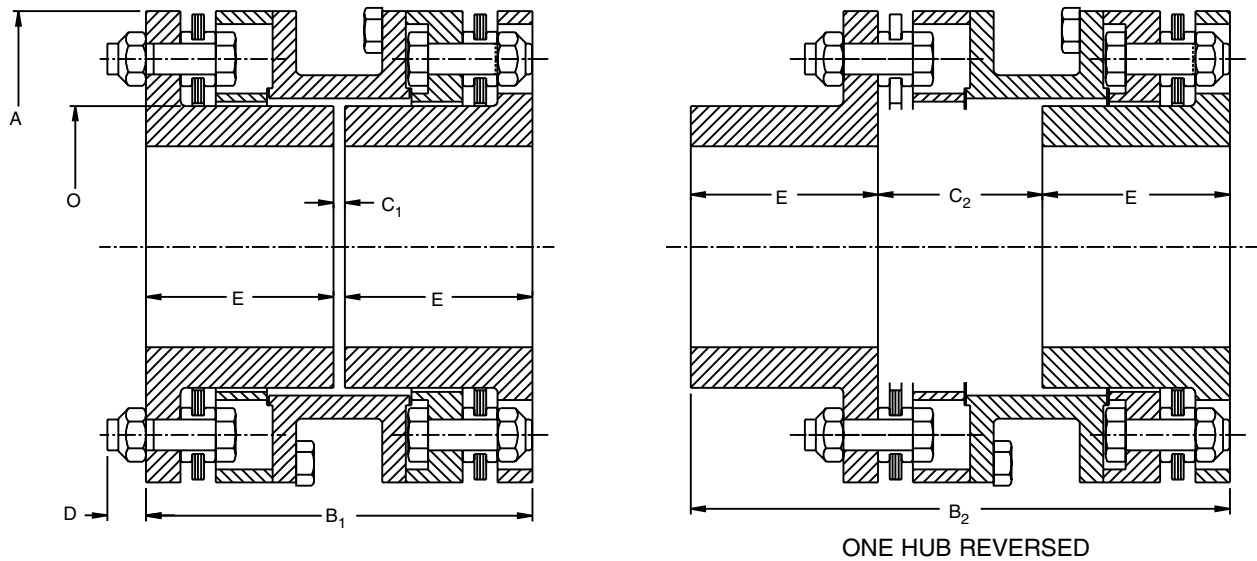

Dimensional Data

Size	A (in)	B1 (in)	B2 (in)	C1 (in)	C2 (in)	D (in)	E (in)	O (in)
103	3.94	3.50	4.94	.125	1.56	.38	1.69	2.10
153	5.38	4.38	6.15	.125	1.90	.52	2.12	2.96
204	6.38	5.62	7.90	.125	2.40	.60	2.75	3.64
254	7.62	6.25	8.72	.175	2.66	.60	3.03	4.56
304	9.00	7.38	10.30	.175	3.11	.74	3.59	5.25
354	10.50	9.00	12.57	.250	3.82	.87	4.38	5.91
404	11.75	10.62	14.81	.250	4.44	1.00	5.19	6.75
454	12.75	10.94	15.32	.3125	4.70	1.00	5.31	7.62
504	13.88	12.38	17.35	.3125	5.28	1.14	6.03	8.19
554	15.12	14.12	19.83	.3125	6.02	1.29	6.91	8.75
604	16.50	15.12	21.21	.3125	6.40	1.38	7.41	9.31
705	20.50	17.75	24.87	.375	7.50	1.65	8.69	11.34
805	23.00	20.00	28.00	.375	8.37	1.94	9.81	12.75
905	25.50	22.25	31.24	.500	9.50	1.94	10.88	15.25

The KD11 coupling is designed to work in place of standard, close coupled gear coupling applications with higher speed service. The power capacity of the KD11 coupling is the highest in the industry, allowing the easiest conversion from a lubricated coupling to a low maintenance disc coupling.

The KD11 is comprised of two hubs, two adapters and two disc packs. The standard coupling hubs may be installed in any of three mounting positions for design and installation flexibility. The bolted adapters give the KD11 coupling the best dynamic balance characteristics and allow the connected equipment to be installed or removed, leaving each assembled half coupling undisturbed.

KD11 disc packs are unitized to greatly reduce the number of loose parts. The standard coupling balance meets AGMA Class 9 as manufactured, dynamic balance to AGMA Class 10 and 11, and conformance to API 610 are available options. The close tolerance bolts and safety overload washers provide superior performance.

For lower speed requirements, consider a KD10 disc coupling. For medium-duty, consider a KD1 disc coupling.

KD11 couplings use HT disc packs.

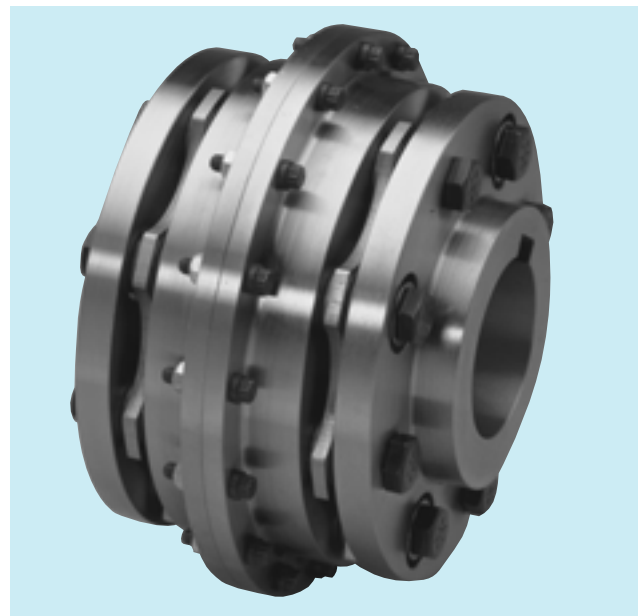

- Heavy duty, highest power capacity
- Minimal shaft separations
- Bolted adapters for higher speeds
- Replacement for standard gear couplings
- Unitized disc packs

Complete Couplings

Coupling Size	Complete Coupling with 2 Std. Hubs	
	Rough Bore	Finish Bore ^①
103	103 KD 11 SS	103 KD 11 SS FB
153	153 KD 11 SS	153 KD 11 SS FB
204	204 KD 11 SS	204 KD 11 SS FB
254	254 KD 11 SS	254 KD 11 SS FB
304	304 KD 11 SS	304 KD 11 SS FB
354	354 KD 11 SS	354 KD 11 SS FB
404	404 KD 11 SS	404 KD 11 SS FB
454	454 KD 11 SS	454 KD 11 SS FB
504	504 KD 11 SS	504 KD 11 SS FB
554	554 KD 11 SS	554 KD 11 SS FB
604	604 KD 11 SS	604 KD 11 SS FB
705	705 KD 11 SS	705 KD 11 SS FB
805	805 KD 11 SS	805 KD 11 SS FB
905	905 KD 11 SS	905 KD 11 SS FB

^① All finish bores and keyways per AGMA 9002-A86 commercial standard tolerances.

Component Parts

Description	Part Number
Standard Hub	SHUB
*HT Disc Pack Assembly	HTDP
*HT Disc Pack Fastener Set	HTFS
*Center Flange Fastener Set	CFFS

* For disc packs and fastener sets, do not include "series" number in the part number.

How to Order Components

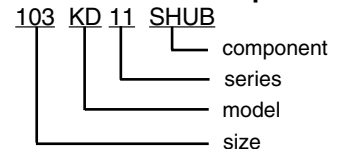

How to Order Disc Packs & Fastener Sets



Visit www.kopflex.com

Selection Data

Size	Max. Bore (in)	Coupling Rating (HP/100 RPM)	Torque Rating		Maximum ^② Speed (RPM)	Total ^① Weight (lbs)	Total ^① WR ² (lb-in ²)	Axial Capacity (in)
			Continuous (in-lb)	Peak (in-lb)				
103	1.50	6.3	4000	8000	14200	9.0	27	±.080
153	2.12	21.6	13600	27200	12500	18.6	90	±.140
204	2.62	57.1	36000	72000	11100	29.2	189	±.110
254	3.25	82.5	52000	104000	9900	43.8	400	±.140
304	3.75	141	89000	178000	8700	69.6	839	±.170
354	4.25	238	150000	300000	7500	111	1790	±.200
404	4.75	340	215000	430000	6600	168	3450	±.225
454	5.50	405	255000	510000	6000	204	5220	±.250
504	5.75	570	360000	720000	5600	272	7920	±.275
554	6.25	800	505000	1010000	4800	364	13200	±.300
604	6.75	1050	660000	1320000	4600	458	21100	±.320
705	8.50	2400	1510000	3020000	3860	824	52400	±.270
805	9.50	3670	2310000	4620000	3450	1220	98000	±.310
905	11.50	4130	2600000	5200000	1520	1520	151000	±.400

① Data based on maximum bores.

② See balance specifications page 93. Consult engineering for applications where speed exceed 75% of max. speed rating.

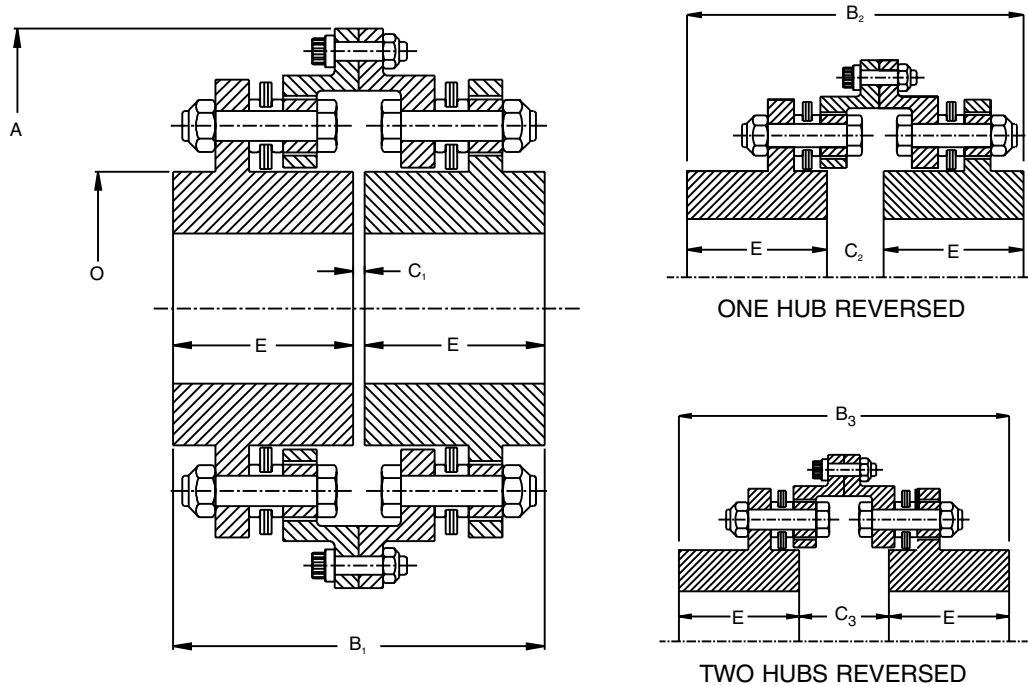

Dimensional Data

Size	A (in)	B1 (in)	B2 (in)	B3 (in)	C1 (in)	C2 (in)	C3 (in)	E (in)	O (in)
103	5.44	3.38	4.56	5.75	.12	1.31	2.50	1.64	2.10
153	6.81	4.12	5.58	7.03	.12	1.58	3.03	2.00	2.96
204	7.81	5.00	6.50	8.00	.12	1.62	3.12	2.44	3.64
254	9.31	6.19	7.22	8.25	.19	1.22	2.25	3.00	4.56
304	10.62	7.19	8.41	9.62	.19	1.41	2.62	3.50	5.25
354	12.28	8.50	10.00	11.50	.25	1.75	3.25	4.12	5.91
404	13.94	9.50	11.50	13.50	.25	2.25	4.25	4.62	6.75
454	15.56	10.56	12.44	14.31	.31	2.19	4.06	5.12	7.62
504	16.69	11.56	13.45	15.34	.31	2.20	4.09	5.62	8.19
554	18.69	12.31	14.48	16.64	.31	2.48	4.64	6.00	8.75
604	20.00	13.31	15.70	18.09	.31	2.70	5.09	6.50	9.31
705	24.00	16.38	19.00	21.62	.38	3.00	5.62	8.00	11.34
805	26.88	18.38	21.53	24.68	.38	3.53	6.68	9.00	12.75
905	30.00	20.50	23.59	26.68	.50	3.59	6.68	10.00	15.25

The KD2 coupling is designed for medium duty applications requiring moderate shaft separations and was specifically engineered to meet API 610 specifications for industrial pump couplings. Consisting of three main parts, two hubs and a factory assembled, flexible center section that installs or drops out as one unit, the KD2 greatly simplifies installation and maintenance.

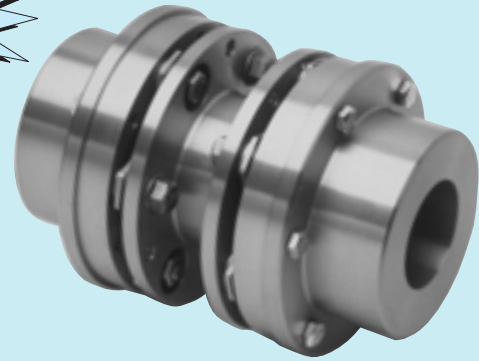

The flexible center section is piloted to ensure excellent dynamic balance. AGMA Class 9 is standard, as-manufactured. Dynamic balance to AGMA Class 10 or Class 11 are available options. An anti-flail safety feature is also included in the flexible center section assembly.

For higher power requirements, consider a KD20 disc coupling. For economy duty, consider a KD21 disc coupling. If a flexible hub design is needed, consider a KD22 disc coupling.

- Medium duty
- Standard shaft separations for industrial pumps
- Factory assembled, flexible center sections
- Designed specifically for API 610
- High flexible, unitized disc packs

KD2 couplings use MT disc packs.

KD2 Rough Bore Part Numbers

Coupling Size	Between Shaft Ends	Complete Coupling w/2 Std. Hubs Rough Bore	Complete Coupling w/1 Std. & 1 Long Hub Rough Bore	Complete Coupling w/2 Long Hubs Rough Bore	Complete Coupling w/1 Jumbo Hub & 1 Std. Hub	Complete Coupling w/2 Jumbo hubs	Complete Coupling w/1 Long & 1 Jumbo Hub	Center Assembly
023	3 1/2	023 KD 2 SS350	023 KD 2 LS350	023 KD 2 LL350	023 KD 2 JS350	023 KD 2 JJ350	023 KD 2 JL350	023 KD 2 CA350
	5	023 KD 2 SS500	023 KD 2 LS500	023 KD 2 LL500	023 KD 2 JS500	023 KD 2 JJ500	023 KD 2 JL500	023 KD 2 CA500
	7	023 KD 2 SS700	023 KD 2 LS700	023 KD 2 LL700	023 KD 2 JS700	023 KD 2 JJ700	023 KD 2 JL700	023 KD 2 CA700
103	3 1/2	103 KD 2 SS350	103 KD 2 LS350	103 KD 2 LL350	103 KD 2 JS350	103 KD 2 JJ350	103 KD 2 JL350	103 KD 2 CA350
	4 3/8	103 KD 2 SS438	103 KD 2 LS438	103 KD 2 LL438	103 KD 2 JS438	103 KD 2 JJ438	103 KD 2 JL438	103 KD 2 CA438
	5	103 KD 2 SS500	103 KD 2 LS500	103 KD 2 LL500	103 KD 2 JS500	103 KD 2 JJ500	103 KD 2 JL500	103 KD 2 CA500
	7	103 KD 2 SS700	103 KD 2 LS700	103 KD 2 LL700	103 KD 2 JS700	103 KD 2 JJ700	103 KD 2 JL700	103 KD 2 CA700
153	4 3/8	153 KD 2 SS438	153 KD 2 LS438	153 KD 2 LL438	153 KD 2 JS438	153 KD 2 JJ438	153 KD 2 JL438	153 KD 2 CA438
	5	153 KD 2 SS500	153 KD 2 LS500	153 KD 2 LL500	153 KD 2 JS500	153 KD 2 JJ500	153 KD 2 JL500	153 KD 2 CA500
	7	153 KD 2 SS700	153 KD 2 LS700	153 KD 2 LL700	153 KD 2 JS700	153 KD 2 JJ700	153 KD 2 JL700	153 KD 2 CA700
203	5	203 KD 2 SS500	203 KD 2 LS500	203 KD 2 LL500	203 KD 2 JS500	203 KD 2 JJ500	203 KD 2 JL500	203 KD 2 CA500
	7	203 KD 2 SS700	203 KD 2 LS700	203 KD 2 LL700	203 KD 2 JS700	203 KD 2 JJ700	203 KD 2 JL700	203 KD 2 CA700
253	7	253 KD 2 SS700	253 KD 2 LS700	253 KD 2 LL700	253 KD 2 JS700	253 KD 2 JJ700	253 KD 2 JL700	253 KD 2 CA700
	8	253 KD 2 SS800	253 KD 2 LS800	253 KD 2 LL800	253 KD 2 JS800	253 KD 2 JJ800	253 KD 2 JL800	253 KD 2 CA800
303	7	303 KD 2 SS700	303 KD 2 LS700	303 KD 2 LL700	303 KD 2 JS700	303 KD 2 JJ700	303 KD 2 JL700	303 KD 2 CA700
	8	303 KD 2 SS800	303 KD 2 LS800	303 KD 2 LL800	303 KD 2 JS800	303 KD 2 JJ800	303 KD 2 JL800	303 KD 2 CA800
353	8	353 KD 2 SS800	353 KD 2 LS800	353 KD 2 LL800	353 KD 2 JS800	353 KD 2 JJ800	353 KD 2 JL800	353 KD 2 CA800
	9	353 KD 2 SS900	353 KD 2 LS900	353 KD 2 LL900	353 KD 2 JS900	353 KD 2 JJ900	353 KD 2 JL900	353 KD 2 CA900
403	9	403 KD 2 SS900	403 KD 2 LS900	403 KD 2 LL900	403 KD 2 JS900	403 KD 2 JJ900	403 KD 2 JL900	403 KD 2 CA900
453	9	453 KD 2 SS900	453 KD 2 LS900	453 KD 2 LL900	453 KD 2 JS900	453 KD 2 JJ900	453 KD 2 JL900	453 KD 2 CA900

Ⓢ **Note: For finish bore add FB to part number and specify bore.**

Ⓢ All finish bores and keyways per AGMA 9002-A86 commercial standard tolerances.

Component Parts

Description	Part Number
Standard Hub	SHUB
Long Hub	LHUB
Jumbo Hub	JHUB
*Center Assembly for x.xx Shaft Separation	CAXXX
**MT Disc Pack	MTDP
**MT Disc Pack Fastener Set	MTFS
**Flange Fastener Set	FFSMT
**Jumbo Hub Fastener Set	JFSHT

* Center assembly includes (2) disc packs, (2) disc pack fastener sets.

** For disc packs and fastener sets, do not include "series" number in the part number.

How to Order Components

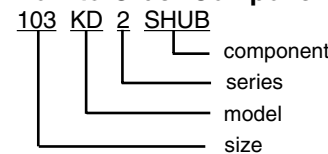

How to Order Disc Packs and Fastener Sets

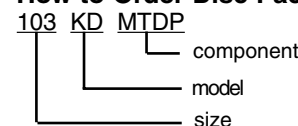

Selection Data

Size	Maximum Bores (in)		Coupling Rating (HP/100 RPM)	Torque Rating		Ⓜ Maximum Speed (RPM)	TotalⓂ Weight (lbs)	TotalⓂ WR ² (lb-in ²)	Spacer Tube Weight per inch		Axial Capacity (in)
	Std. & Long Hub	Jumbo Hub		Continuous (in-lb)	Peak (in-lb)				Weight (lbs)	WR ² (lb-in ²)	
023	1.50	2.00	2.3	1450	2900	25500	5.5	10.5	0.17	0.10	±.040
103	1.88	2.75	4.3	2710	5420	17000	9.9	22.0	0.44	0.45	±.060
153	2.88	4.00	12.5	7880	15760	14200	23.2	93.1	0.54	1.06	±.075
203	3.25	4.62	22.9	14400	28800	12800	35.5	205	0.56	1.67	±.090
253	4.00	5.62	37.5	23600	47200	11500	58.8	475	0.73	3.59	±.105
303	4.75	6.50	60.0	37800	75600	10000	89.6	989	1.14	7.52	±.125
353	5.50	7.62	100	63000	126000	8500	145	2160	1.57	12.70	±.150
403	6.25	8.75	155	97700	195000	7500	220	4290	1.84	19.80	±.175
453	7.25	9.38	205	129000	258000	7000	261	6180	2.01	27.00	±.200

① Data based on min. "C" dimensions, maximum bores and standard hubs.

② See balance specifications page 93. Consult engineering for applications where speed exceed 75% of max. speed rating.

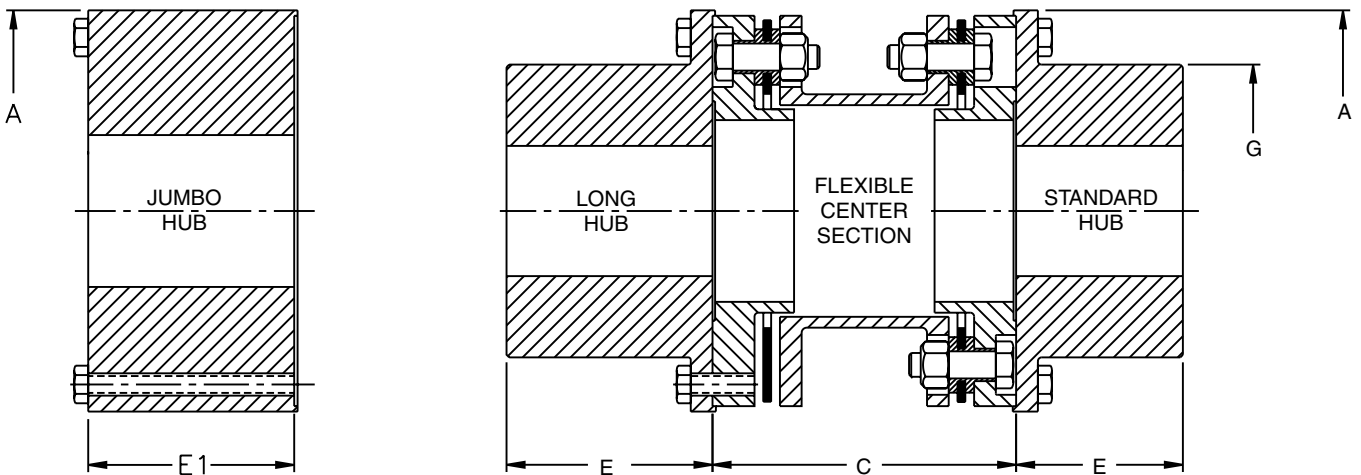

Note: "C" dimension = center assembly length.

Dimensional Data

Size	Rough Bore	A (in)	Max C' Bore (in)	C Min. (in)	E (in)	E1 (in)	G (in)	Stock "C" Dimension (in)						
								3 1/2	4 3/8	5	7	8	9	
023	0.31	3.54	1.88	2.50	1.57	1.57	2.16	X		X	X			
103	0.50	4.31	2.38	3.50	1.50	2.50	2.62	X	X	X	X			
153	0.75	5.69	3.88	4.38	2.00	3.12	4.12		X	X	X			
203	1.00	6.75	4.50	4.81	2.25	3.62	4.75			X	X			
253	1.00	8.00	5.50	5.75	2.88	4.25	5.75				X	X		
303	1.50	9.25	6.44	6.50	3.38	4.75	6.75				X	X		
353	2.00	10.75	7.31	7.62	4.00	5.38	7.75					X	X	
403	2.50	12.25	8.50	9.00	4.44	6.12	9.00						X	X
453	3.00	13.25	9.62	9.00	4.81	6.75	10.12							X

Note: Shaft separations longer than stock may be accommodated by using stock center assemblies and counterboring and overhanging long hubs to make up the difference. Shaft fit length should be equal to "E" or greater. Consult Kop-Flex for more details.



Visit www.kopflex.com

KD20 Spacer Coupling

The KD20 coupling is designed for heavy duty applications requiring moderate shaft separations, and was specifically engineered to meet API 610 specifications for industrial pump couplings. Consisting of three main parts, two hubs and a factory assembled flexible center section which installs or drops out as one unit, the KD20 greatly simplifies installation or maintenance.

The larger size couplings available in the KD20 Series allow application to larger, high power machines. The flexible center section is piloted to provide excellent dynamic balance. AGMA Class 9 is standard, as manufactured. Dynamic balance to AGMA Class 10 or Class 11 are available options. The close tolerance bolts and safety overload washers provide superior performance and trouble-free operation. An anti-flail safety feature is also included in the flexible center section assembly.

For smaller sizes or lower power requirements, consider a KD2 disc coupling. For economy duty, consider a KD21 disc coupling. If a flexible hub design is needed, consider a KD22 disc coupling.

KD20 couplings use HT disc packs.

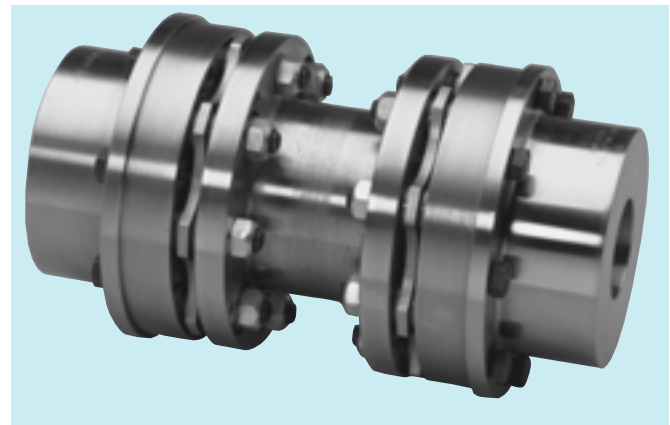

- Heavy duty, larger sizes
- Standard shaft separations for industrial pumps
- Factory assembled, flexible center sections
- Designed specifically for API 610
- High power, unitized disc packs

KD20 Rough Bore Part Numbers

Coupling Size	Between Shaft Ends	Complete Coupling w/2 Std. Hubs Rough Bore	Complete Coupling w/1 Std. & 1 Long Hub Rough Bore	Complete Coupling w/2 Long Hubs Rough Bore	Complete Coupling w/1 Jumbo Hub & 1 Std. Hub	Complete Coupling w/2 Jumbo hubs	Complete Coupling w/1 Long & 1 Jumbo Hub	Center Assembly
204	7	204 KD 20 SS700	204 KD 20 LS700	204 KD 20 LL700	204 KD 20 JS700	204 KD 20 JJ700	204 KD 20 JL700	204 KD 20 CA700
	8	204 KD 20 SS800	204 KD 20 LS800	204 KD 20 LL800	204 KD 20 JS800	204 KD 20 JJ800	204 KD 20 JL800	204 KD 20 CA800
	9	204 KD 20 SS900	204 KD 20 LS900	204 KD 20 LL900	204 KD 20 JS900	204 KD 20 JJ900	204 KD 20 JL900	204 KD 20 CA900
	10	204 KD 20 SS1000	204 KD 20 LS1000	204 KD 20 LL1000	204 KD 20 JS1000	204 KD 20 JJ1000	204 KD 20 JL1000	204 KD 20 CA1000
	12	204 KD 20 SS1200	204 KD 20 LS1200	204 KD 20 LL1200	204 KD 20 JS1200	204 KD 20 JJ1200	204 KD 20 JL1200	204 KD 20 CA1200
254	7	254 KD 20 SS700	254 KD 20 LS700	254 KD 20 LL700	254 KD 20 JS700	254 KD 20 JJ700	254 KD 20 JL700	254 KD 20 CA700
	8	254 KD 20 SS800	254 KD 20 LS800	254 KD 20 LL800	254 KD 20 JS800	254 KD 20 JJ800	254 KD 20 JL800	254 KD 20 CA800
	9	254 KD 20 SS900	254 KD 20 LS900	254 KD 20 LL900	254 KD 20 JS900	254 KD 20 JJ900	254 KD 20 JL900	254 KD 20 CA900
	10	254 KD 20 SS1000	254 KD 20 LS1000	254 KD 20 LL1000	254 KD 20 JS1000	254 KD 20 JJ1000	254 KD 20 JL1000	254 KD 20 CA1000
	12	254 KD 20 SS1200	254 KD 20 LS1200	254 KD 20 LL1200	254 KD 20 JS1200	254 KD 20 JJ1200	254 KD 20 JL1200	254 KD 20 CA1200
304	7	304 KD 20 SS700	304 KD 20 LS700	304 KD 20 LL700	304 KD 20 JS700	304 KD 20 JJ700	304 KD 20 JL700	304 KD 20 CA700
	8	304 KD 20 SS800	304 KD 20 LS800	304 KD 20 LL800	304 KD 20 JS800	304 KD 20 JJ800	304 KD 20 JL800	304 KD 20 CA800
	9	304 KD 20 SS900	304 KD 20 LS900	304 KD 20 LL900	304 KD 20 JS900	304 KD 20 JJ900	304 KD 20 JL900	304 KD 20 CA900
	10	304 KD 20 SS1000	304 KD 20 LS1000	304 KD 20 LL1000	304 KD 20 JS1000	304 KD 20 JJ1000	304 KD 20 JL1000	304 KD 20 CA1000
	12	304 KD 20 SS1200	304 KD 20 LS1200	304 KD 20 LL1200	304 KD 20 JS1200	304 KD 20 JJ1200	304 KD 20 JL1200	304 KD 20 CA1200
354	9	354 KD 20 SS900	354 KD 20 LS900	354 KD 20 LL900	354 KD 20 JS900	354 KD 20 JJ900	354 KD 20 JL900	354 KD 20 CA900
	10	354 KD 20 SS1000	354 KD 20 LS1000	354 KD 20 LL1000	354 KD 20 JS1000	354 KD 20 JJ1000	354 KD 20 JL1000	354 KD 20 CA1000
	12	354 KD 20 SS1200	354 KD 20 LS1200	354 KD 20 LL1200	354 KD 20 JS1200	354 KD 20 JJ1200	354 KD 20 JL1200	354 KD 20 CA1200
	14	354 KD 20 SS1400	354 KD 20 LS1400	354 KD 20 LL1400	354 KD 20 JS1400	354 KD 20 JJ1400	354 KD 20 JL1400	354 KD 20 CA1400
404	10	404 KD 20 SS1000	404 KD 20 LS1000	404 KD 20 LL1000	404 KD 20 JS1000	404 KD 20 JJ1000	404 KD 20 JL1000	404 KD 20 CA1000
	12	404 KD 20 SS1200	404 KD 20 LS1200	404 KD 20 LL1200	404 KD 20 JS1200	404 KD 20 JJ1200	404 KD 20 JL1200	404 KD 20 CA1200
	14	404 KD 20 SS1400	404 KD 20 LS1400	404 KD 20 LL1400	404 KD 20 JS1400	404 KD 20 JJ1400	404 KD 20 JL1400	404 KD 20 CA1400
454	10	454 KD 20 SS1000	454 KD 20 LS1000	454 KD 20 LL1000	454 KD 20 JS1000	454 KD 20 JJ1000	454 KD 20 JL1000	454 KD 20 CA1000
	12	454 KD 20 SS1200	454 KD 20 LS1200	454 KD 20 LL1200	454 KD 20 JS1200	454 KD 20 JJ1200	454 KD 20 JL1200	454 KD 20 CA1200
	14	454 KD 20 SS1400	454 KD 20 LS1400	454 KD 20 LL1400	454 KD 20 JS1400	454 KD 20 JJ1400	454 KD 20 JL1400	454 KD 20 CA1400

Ⓢ All finish bores and keyways per AGMA 9002-A86 commercial standard tolerances.

Ⓢ Note: For finish bore add FB to part number and specify bore.

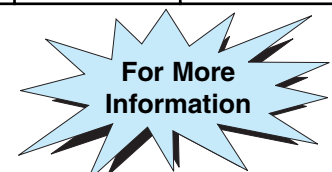

Visit www.kopflex.com

Selection Data

Size	Max. Bore (in)		Coupling Rating (HP/100 RPM)	Torque Rating		② Maximum Speed (RPM)	Total① Weight (lbs)	Total① WR ² (lb-in ²)	Spacer Tube per inch		Axial Capacity (in)
	Std. & Long Hub	Jumbo Hub		Continuous (in-lb)	Peak (in-lb)				Weight (lbs)	WR ² (lb-in ²)	
204	3.25	4.62	57.1	36000	72000	13000	39.2	230	0.81	2.67	±.110
254	4.00	5.62	82.5	52000	104000	11200	61.2	510	0.79	4.36	±.140
304	4.75	6.5	141	89000	178000	9900	104	1190	1.17	8.06	±.170
354	5.50	7.62	238	150000	300000	8800	172	2630	1.96	17.0	±.200
404	6.25	8.75	340	215000	430000	7800	251	4920	2.21	24.3	±.225
454	7.25	9.38	405	255000	510000	7200	302	7200	2.54	37.0	±.250
504	7.50	-	570	360000	720000	6600	427	11600	3.67	62.6	±.275
554	8.25	-	800	505000	1010000	6100	569	18200	3.89	74.7	±.300
604	9.00	-	1050	660000	1320000	5600	777	29500	5.21	115	±.320
705	10.88	-	2400	1510000	3020000	4500	1360	77500	9.40	303	±.270
805	12.25	-	3670	2310000	4620000	4000	2060	150000	12.6	507	±.310
905	13.50	-	4130	2600000	5200000	3600	2490	227000	11.7	662	±.400

① Data based on min. "C" dimensions, maximum bores and standard hubs.

② See balance specifications page 93. Consult engineering for applications where speed exceed 75% of max. speed rating.

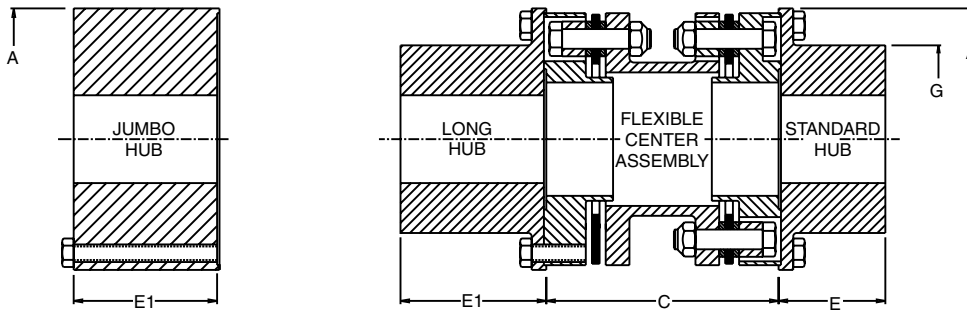

Note: "C" dimension = center assembly length.

Dimensional Data

Size	A (in)	Max. C' Bore (in)	Min. C (in)	E (in)	E1 (in)	G (in)	No (in)	Ni (in)	Stock "C" Dimension (in.)					
									7	8	9	10	12	14
204	6.62	4.50	6.00	2.25	3.62	4.75	3.88	3.38	X	X	X	X	X	X
254	7.88	5.50	6.00	2.88	4.25	5.75	4.88	4.50	X	X	X	X	X	X
304	9.25	6.44	7.00	3.38	4.75	6.75	5.50	5.00	X	X	X	X	X	X
354	10.75	7.31	8.50	4.00	5.38	7.75	6.25	5.50			X	X	X	X
404	12.00	8.50	10.00	4.44	6.12	9.00	7.00	6.25				X	X	X
454	13.00	9.62	10.00	4.81	6.75	10.12	8.00	7.25				X	X	X
504	14.12	9.88	11.00	6.88	-	10.50	8.75	7.75						
554	15.38	10.75	12.50	7.50	-	11.50	9.25	8.25						
604	16.88	12.00	13.25	8.75	-	12.75	10.00	8.75						
705	20.88	14.50	16.00	9.75	-	15.25	12.25	10.38						
805	23.38	16.38	19.00	10.75	-	17.25	13.75	11.50						
905	25.88	18.00	19.00	11.75	-	19.00	15.88	14.12						

* Long hubs are available for sizes 204 to 454 only.

Component Parts

Description	Part Number
Standard Hub	SHUB
Long Hub	LHUB
Jumbo Hub	JHUB
*Center Assembly for x.xx Shaft Separation	CAXXX
**HT Disc Pack Assembly	HTDP
**HT Disc Pack Fastener Set	HTFS
**Flange Fastener Set	FFSHT
**Jumbo Hub Fastener Set	JFSHT

* Center assembly includes (2) disc packs, (2) disc pack fastener sets.

** For disc packs and fastener sets, do not include "series" number in the part number.

How to Order Components

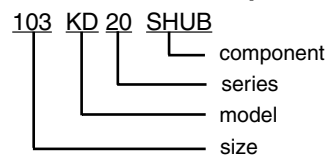

How to Order Disc Packs and Fastener Sets



Note: Shaft separations longer than stock may be accommodated by using stock center assemblies and counterboring and overhanging long hubs to make up the difference. Shaft fit length should be equal to "E" or greater. Consult Kop-Flex for more details.

The KD21 coupling is designed for medium and heavy duty applications requiring moderate shaft separations. The minimal number of components yields an economical disc coupling solution to spacer applications. The larger sizes available in the KD21 series allow application to larger, high power machines.

Consisting of three main parts: two hubs and a center spacer that installs or drops out using unitized disc packs, the KD21 simplifies installation or maintenance. The unitized disc packs and close tolerance bolts provide good dynamic balance. AGMA Class 9 is standard, as-manufactured. Dynamic balance to AGMA Class 10 and conformance to API 610 are available options. The close tolerance bolts and safety overload washers provide superior performance and trouble-free operation.

If a coupling with a factory-assembled flexible center section is desired, consider a KD20 or KD2 disc coupling. For lower power requirements, consider a KD50 disc coupling. If a flexible hub design is needed, consider a KD22 disc coupling.

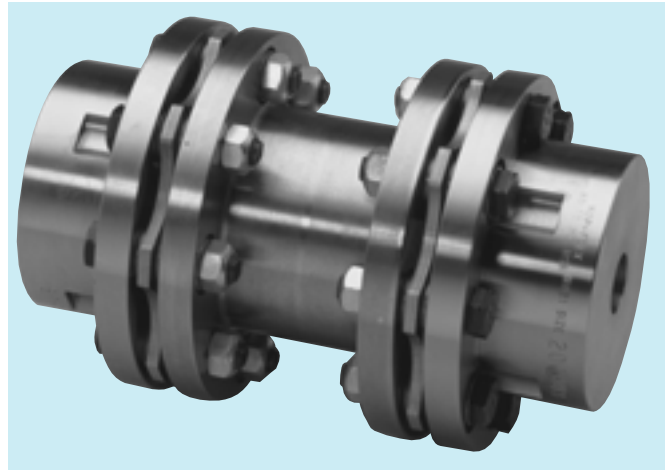

- Heavy duty, larger sizes
- Economical spacer series
- Standard shaft separations for industrial pumps
- Drop-out, unitized disc packs

KD21 couplings use HT disc packs.



Coupling Size	Between Shaft Ends*	Complete Coupling with 2 Std. Hubs		Complete Coupling with 1 Std. Hub and 1 Long Hub	
		Rough Bore	Finish Bore	Rough Bore	Finish Bore
053*	5	053 KD2 SS500	NA	NA	NA
103	3 1/2	103 KD 21 SS350	103 KD 21 SS350 FB	103 KD 21 LS350	103 KD 21 LS350 FB
	5	103 KD 21 SS500	103 KD 21 SS500 FB	103 KD 21 LS500	103 KD 21 LS500 FB
153	5	153 KD 21 SS500	153 KD 21 SS500 FB	153 KD 21 LS500	153 KD 21 LS500 FB
204	5	204 KD 21 SS500	204 KD 21 SS500 FB	204 KD 21 LS500	204 KD 21 LS500 FB
	7	204 KD 21 SS700	204 KD 21 SS700 FB	204 KD 21 LS700	204 KD 21 LS700 FB
	9	204 KD 21 SS900	204 KD 21 SS900 FB	204 KD 21 LS900	204 KD 21 LS900 FB
	10	204 KD 21 SS1000	204 KD 21 SS1000 FB	204 KD 21 LS1000	204 KD 21 LS1000 FB
	12	204 KD 21 SS1200	204 KD 21 SS1200 FB	204 KD 21 LS1200	204 KD 21 LS1200 FB
254	5	254 KD 21 SS500	254 KD 21 SS500 FB	254 KD 21 LS500	254 KD 21 LS500 FB
	7	254 KD 21 SS700	254 KD 21 SS700 FB	254 KD 21 LS700	254 KD 21 LS700 FB
	9	254 KD 21 SS900	254 KD 21 SS900 FB	254 KD 21 LS900	254 KD 21 LS900 FB
	14	254 KD21 SS1400	254 KD21 SS1400 FB	254 KD 21 LS1400	254 KD 21 LS1400 FB
304	7	304 KD 21 SS700	304 KD 21 SS700 FB	304 KD 21 LS700	304 KD 21 LS700 FB
	9	304 KD 21 SS900	304 KD 21 SS900 FB	304 KD 21 LS900	304 KD 21 LS900 FB
	14	304 KD 21 SS1400	304 KD 21 SS1400 FB	304 KD 21 LS1400	304 KD 21 LS1400 FB
354	7	354 KD 21 SS700	354 KD 21 SS700 FB	354 KD 21 LS700	354 KD 21 LS700 FB
	9	354 KD 21 SS900	354 KD 21 SS900 FB	354 KD 21 LS900	354 KD 21 LS900 FB
	14	354 KD 21 SS1400	354 KD 21 SS1400 FB	354 KD 21 LS1400	354 KD 21 LS1400 FB
404	8	404 KD 21 SS800	404 KD 21 SS800 FB	404 KD 21 LS800	404 KD 21 LS800 FB
	14	404 KD 21 SS1400	404 KD 21 SS1400 FB	404 KD 21 LS1400	404 KD 21 LS1400 FB
454	8	454 KD 21 SS800	454 KD 21 SS800 FB	454 KD 21 LS800	454 KD 21 LS800 FB

* For non-standard shaft separations, spacers can be manufactured to order.

Component Parts

Description	Part Number
Standard Hub	SHUB
Long Hub	LHUB
*HT Disc Pack Assembly	HTDP
*HT Disc Pack Fastener Set	HTFS

* For disc packs and fastener sets, do not include "series" number in the part number.

How to Order Components

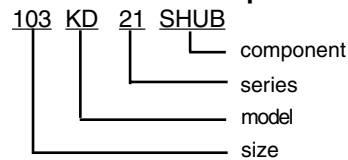

How to Order Disc Packs and Fastener Sets



Visit www.kopflex.com

Selection Data

Size	Max. Bore (in)	Coupling Rating (HP/100 RPM)	Torque Rating		Maximum Speed RPM	Total \varnothing Weight (lbs)	Total \varnothing WR ² (lb-in ²)	Spacer Tube per inch		Axial Capacity (in)
			Continuous (in-lb)	Peak (in-lb)				Weight (lbs)	WR ² (lb-in ²)	
053	1.75	3.2	2000	4000	8200	7.7	16	0.50	0.42	±.055
103	1.75	6.3	4000	8000	18200	7.8	16	0.24	0.27	±.080
153	2.50	21.6	13600	27200	14800	17.7	67	0.39	0.80	±.140
204	3.00	57.1	36000	72000	13000	29.8	160	0.81	2.67	±.110
254	3.75	82.5	52000	104000	11200	44.3	336	0.79	4.36	±.140
304	4.50	141	89000	178000	9900	70.4	745	1.17	8.06	±.170
354	5.00	238	150000	300000	8800	117	1640	1.96	17.0	±.200
404	5.50	340	215000	430000	7800	177	3150	2.21	24.3	±.225
454	6.38	405	255000	510000	7200	205	4360	2.54	37.0	±.250
504	7.00	570	360000	720000	6600	305	7460	3.67	62.6	±.275
554	7.75	800	505000	1010000	6100	402	11800	3.89	74.7	±.300
604	8.50	1050	660000	1320000	5600	512	17800	5.21	115	±.320
705	10.75	2400	1510000	3020000	4500	922	50000	9.40	303	±.270
805	12.00	3670	2310000	4620000	4000	1350	93800	12.6	507	±.310
905	13.50	4130	2600000	5200000	3600	1700	146000	11.8	675	±.400

- ① Data based on min. "C" dimensions and maximum bores.
- ② See balance specifications page 93. Consult engineering for applications where speed exceed 75% of max. speed rating.

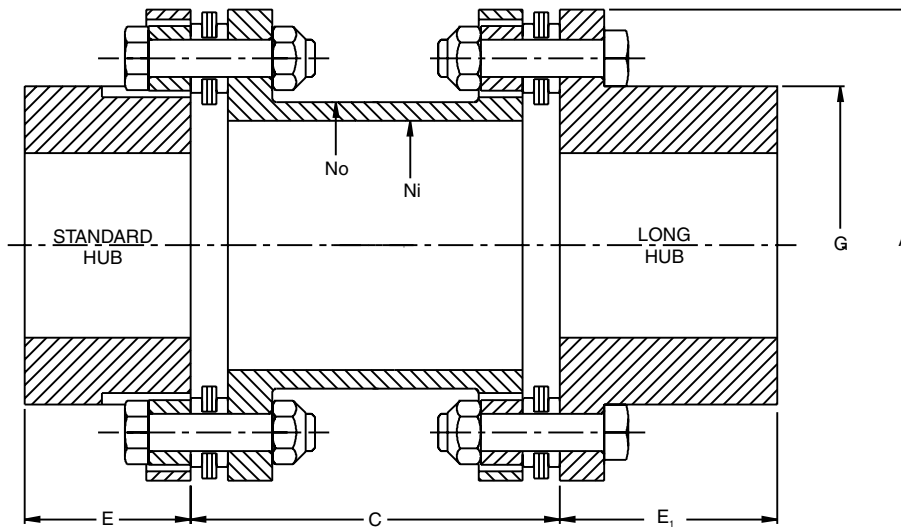

Note: "C" dimension = length of spacer plus (2) disc packs (including flat washers).

Dimensional Data

Size	A (in)	Min. C (in)	E (in)	E1* (in)	G (in)	No (in)	Ni (in)	Stock "C" Dimension (in.)								
								3.5	5	7	8	9	10	12	14	
053	3.94	3.00	1.62	-	2.56	2.12	1.50	-	X	-	-	-	-	-	-	-
103	3.94	2.75	1.66	1.94	2.57	2.25	2.00	X	X	-	-	-	-	-	-	-
153	5.38	3.38	1.94	2.44	3.54	3.00	2.69	-	X	-	-	-	-	-	-	-
204	6.38	3.88	2.38	3.03	4.32	3.88	3.38	-	X	X	-	X	X	X	-	-
254	7.62	3.88	3.00	3.59	5.34	4.88	4.50	-	X	X	-	X	-	-	-	X
304	9.00	4.75	3.56	4.19	6.16	5.50	4.94	-	-	X	-	X	-	-	-	X
354	10.50	5.75	4.12	4.75	6.99	6.25	5.50	-	-	X	-	X	-	-	-	X
404	11.75	6.62	4.62	5.31	7.91	7.00	6.25	-	-	-	X	-	-	-	-	X
454	12.75	6.62	5.25	6.03	8.83	8.00	7.25	-	-	-	X	-	-	-	-	-
504	13.88	7.50	5.88	-	9.62	8.75	7.75	-	-	-	-	-	-	-	-	-
554	15.12	8.62	7.16	-	10.48	9.25	8.25	-	-	-	-	-	-	-	-	-
604	16.50	9.12	7.66	-	11.33	10.00	8.75	-	-	-	-	-	-	-	-	-
705	20.50	10.88	9.00	-	14.07	12.25	10.00	-	-	-	-	-	-	-	-	-
805	23.00	13.00	10.12	-	15.73	13.75	11.50	-	-	-	-	-	-	-	-	-
905	25.50	13.00	11.81	-	17.88	15.88	14.12	-	-	-	-	-	-	-	-	-

* Long hubs are available for sizes 103 to 454 only.

Note: Shaft separations longer than stock may be accommodated by using stock spacers and counterboring and overhanging long hubs to make up the difference. Shaft fit length should be equal to "E" or greater. Consult Kop-Flex for more details.

The KD22 coupling is designed to be the most direct replacement for standard spacer style gear couplings and is meant for heavy duty applications where the flexible section must be located on the equipment shafts. The power capacity of the KD22 coupling is the highest in the industry, allowing the easiest conversion from a lubricated coupling to a low maintenance disc coupling.

Consisting of three main parts, two flexible half couplings and a center spacer that installs or drops out, the KD22 simplifies installation or maintenance and allows the connected equipment to be installed or removed, keeping each half coupling completely assembled. The unitized disc packs and close tolerance bolts provide good dynamic balance. AGMA Class 8 is standard, as manufactured. Dynamic balance to AGMA Class 9 and conformance to API 610 are available options.

The KD22 coupling employs standard gear coupling spacer flanges that can be used to provide standard electrical insulation or shear cartridge features.

For other spacer designs, consider KD20 or KD21 disc couplings. For lower power requirements, consider a KD2 disc coupling.

KD22 couplings use HT Disc Packs.

Complete KD22 couplings are made to order. Contact your local Emerson Power Transmission representative to order.

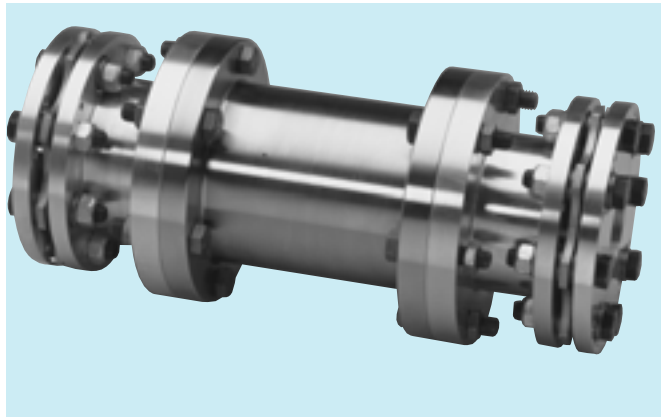

- Heavy duty, larger sizes
- Flexible shaft hubs
- Reduced overhung weight
- High power, unitized disc packs

Component Parts

Description	Part Number
Standard Hub	SHUB
*Flex Half	FH
**HT Disc Pack Assembly	HTDP
**HS Disc Pack Fastener Set	HSFS

* Flex halves are designated by disc/spacer size, and include (1) disc pack and (1) disc pack fastener set.

** For disc packs components, do not include "series" number in the part number.

Spacer Flange Data

Coupling Size	Spacer Fastener		Spacer Flange Size
	Part No.	Wt.	
103	1 EB FS	1	1.0
153	1 1/2 EB FS	1	1.5
204	2 EB FS	1	2.0
254	2 1/2 EB FS	2	2.5
304	3 EB FS	3	3.0
354	3 1/2 EB FS	5	3.5
404	4 EB FS	5	4.0
454	4 1/2 EB FS	5	4.5
504	5 EB FS	7	5.0
554	5 1/2 EB FS	9	5.5
604	6 EB FS	14	6.0
705	7 EB FS	14	7.0
805	8 EB FS	28	8.0
905	9 EB FS	34	9.0

How to Order Hubs

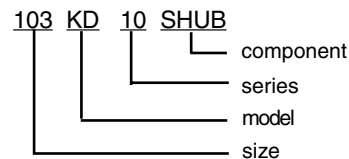

Note: KD10 hubs are used on KD22 couplings.

How to Order Flex Halves

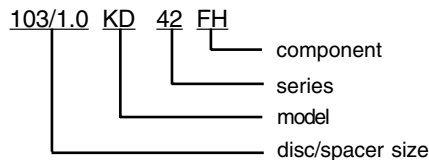

Note: KD42 flex halves are used on KD22 couplings. See spacer flange data for sizes.

How to Order Disc Pack Components

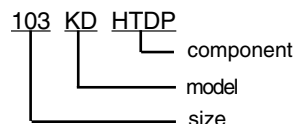

Visit www.kopflex.com

Selection Data

Size	Max. Bore (in.)	Max. Continuous Rating HP/100 RPM	Torque Rating		Maximum Speed RPM	Axial Capacity (in)
			Continuous (in-lb)	Peak (in-lb)		
103	1.50	6.3	4000	8000	17000	±.080
153	2.12	21.6	13600	27200	13500	±.140
204	2.62	57.1	36000	72000	12000	±.110
254	3.25	82.5	52000	104000	10600	±.140
304	3.75	141	89000	178000	9800	±.170
354	4.25	238	150000	300000	8400	±.200
404	4.75	340	215000	430000	7400	±.225
454	5.50	405	255000	510000	6750	±.250
504	5.75	570	360000	720000	6000	±.275
554	6.25	800	505000	1010000	5500	±.300
604	6.75	1050	660000	1320000	5100	±.320
705	8.50	2400	1510000	3020000	4500	±.270
805	9.50	3670	1278000	2556000	3950	±.310
905	11.50	4130	1784000	3568000	3300	±.400

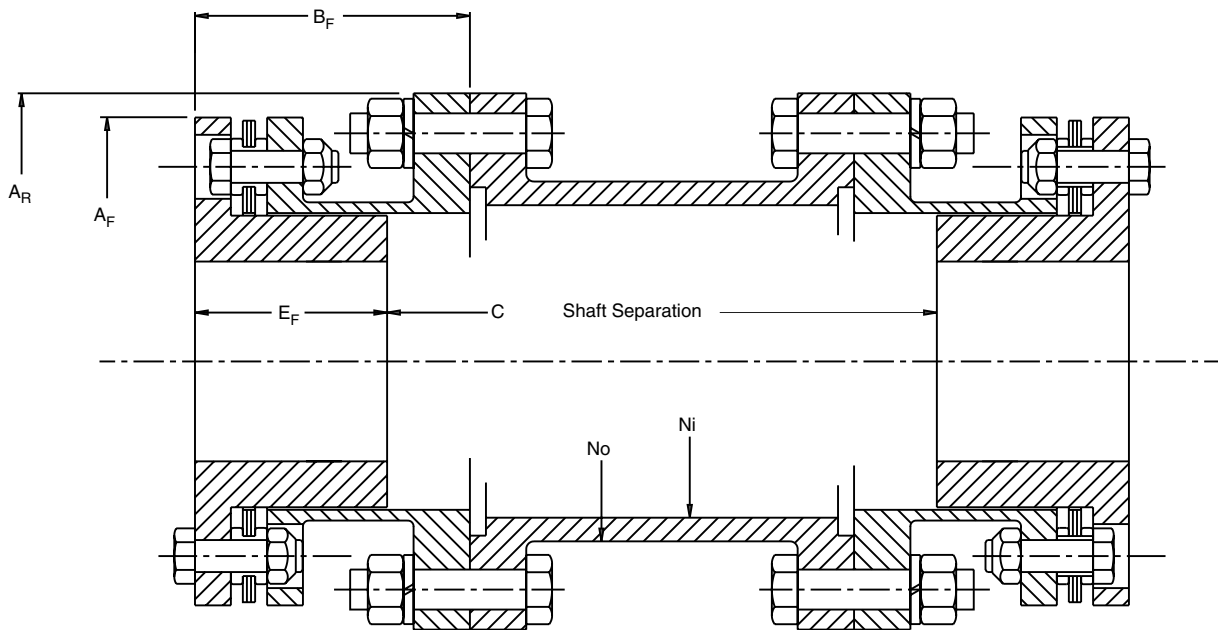

Dimensional Data

Size	A _F (in)	A _R (in)	B _F (in)	E _F (in)	Min. C (in)	N _O (in)	N _I (in)
103	3.94	4.56	2.35	1.69	3.50	2.88	2.50
153	5.38	6.00	3.16	2.12	5.00	3.75	3.25
204	6.38	7.00	4.04	2.75	6.00	4.75	4.12
254	7.62	8.38	4.44	3.03	7.00	5.62	4.88
304	9.00	9.44	5.00	3.59	7.00	6.62	5.81
354	10.50	11.00	5.79	4.38	7.50	7.75	6.81
404	11.75	12.50	6.62	5.19	8.00	8.75	7.81
454	12.75	13.62	6.74	5.31	8.00	9.75	8.75
504	13.88	15.31	7.46	6.03	9.00	11.00	9.81
554	15.12	16.75	8.47	6.91	8.00	12.00	10.69
604	16.50	18.00	8.22	7.41	7.00	18.50	12.19
705	20.50	20.75	9.50	8.69	7.00	15.00	13.69
805	23.00	23.25	11.00	9.81	9.00	17.75	16.98
905	25.50	26.00	11.82	10.88	9.00	19.88	19.00

Designed specifically for cooling tower drives and long span applications, the KD33 coupling is easy to handle, install and maintain. The drive shaft is a corrosion resistant, lightweight composite tube of either special fiberglass or carbon graphite fibers engineered to provide the optimum combination of strength and bending stiffness required of cooling tower couplings.

The coupling hubs, adapters, disc packs and hardware are all stainless steel for high strength and corrosion resistance. The unitized disc packs are capable of up to 1/2° continuous misalignment, which provides trouble-free operation using close tolerance bolts and standard drive shaft dynamic balance.

The couplings shown below are stocked and available for quick supply. Two weeks standard delivery or 24-hour premium delivery is available.

For longer shaft spans or special designs, consult Kop-Flex.



- Composite tubes for low weight and corrosion resistance
- Stainless steel metal components
- Quick delivery
- Highly flexible, unitized disc packs

KD33 Couplings use CT Disc Packs.

Part Numbers

Complete KD33 Coupling, Class 1 (Stainless Steel & Composite Shaft)
Shaft Separation Must Be Specified at Time of Order.

Size	Drive Shaft	Maximum DBSE		Complete Coupling Part No.	Disc Pack Part No.	Disc Pack Fastener Set Part No.
		@ 1800 RPM	@ 1500 RPM			
153	4" E-Glass	96	105	153 KD 33 EG	153 KD CTD	153 KD CTFS
153	4" Carbon	130	141	153 KD 33 C		
203	6" E-Glass	118	128	203 KD 33 EG	203 KD CTD	203 KD CTFS
203	6" Carbon	160	172	203 KD 33 C		
253	6" E-Glass	116	128	253 KD 33 EG	253 KD CTD	253 KD CTFS
253	6" Carbon	160	172	253 KD 33 C		

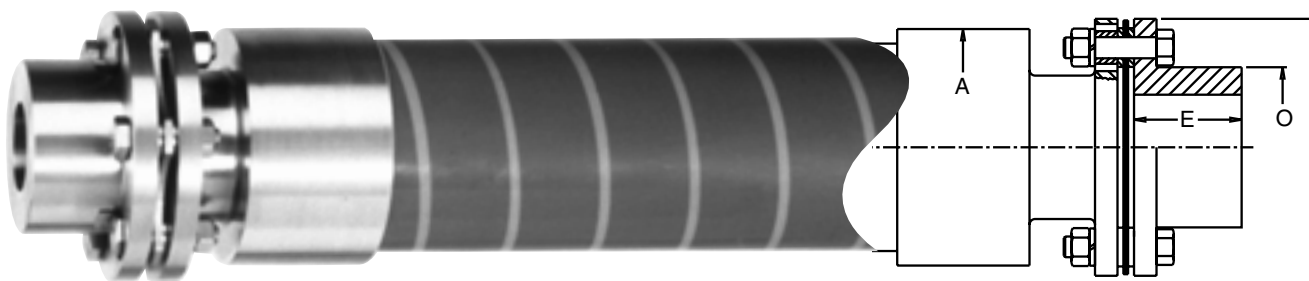
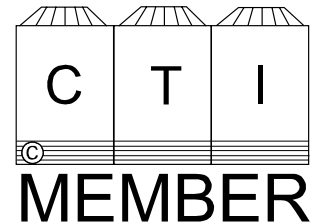

Selection and Dimensional Data

Size	Max Bore (inches)	Coupling Rating HP/100 RPM	Torque Rating (in-lb)		Nominal Tube Dia. (in)	Composite Tube Material	Maximum DBSE @ 1800 RPM (in)	Maximum DBSE @ 1500 RPM (in)	Dimensions			
			Continuous	Peak					A (in)	E (in)	O (in)	D (in)
153	2.38	12.5	7880	15760	4	E-GLASS	96	105	4.8	2.25	3.35	5.38
					4	CARBON	130	141				
203	3.00	22.9	14400	28800	6	E-GLASS	118	128	6.9	2.50	4.26	6.38
					6	CARBON	160	172				
253	3.75	37.5	23600	47200	6	E-GLASS	118	128	6.9	3.00	5.26	7.69
					6	CARBON	160	172				

Precision Shaft Couplings

For Turbomachinery Gas Turbine Drives

With more than 80 years of coupling design and manufacturing history, Kop-Flex is the one company that has broad-based experience in supplying the three types of high performance couplings used on turbomachinery. Kop-Flex has a coupling to fit your application.

All Kop-Flex couplings meet, or can be engineered to meet, OEM and API 671 specifications. Kop-Flex turbomachinery couplings can be designed and manufactured to meet your specific application needs. All couplings are designed using the latest in engineering technologies -- CAD, FEA, precision CNC machine tools and Kop-Flex expertise.

The High Performance Gear Coupling

- Thousands in service
- Choose from straight or crowned nitrided gear teeth, depending on your application
- Precision lapped teeth, if required
- Heat treated alloy components

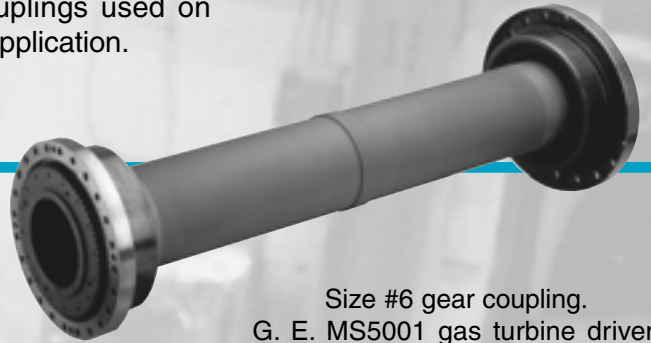

Size #6 gear coupling. G. E. MS5001 gas turbine driven compressor train. 35,000 HP @ 5100 RPM. Made of 4140 HT alloy with nitrided teeth and lapped to improve load carrying capabilities. The Koplon* tooth coating makes for ease of operation during initial coupling break-in.

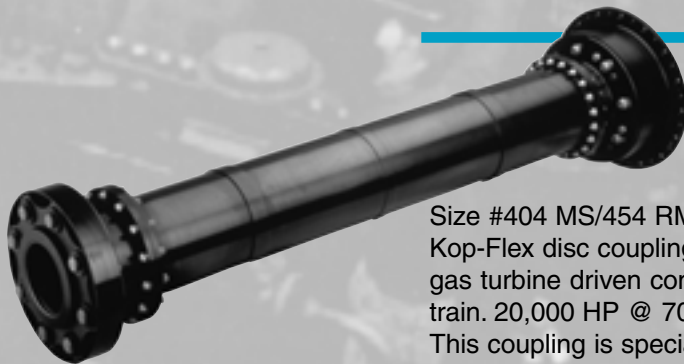

Size #404 MS/454 RM Kop-Flex disc coupling. Ruston gas turbine driven compressor train. 20,000 HP @ 7000 RPM. This coupling is specially designed to give the optimum weight/CG combination needed for high speed turbine/compressor applications.

The Kop-Flex High Performance Flexible Disc Coupling

- Introduced in 1985, with thousands now in service
- Heat treated alloy components
- Coated stainless steel disc packs
- Optional Inconel discs

More than 80 years of experience, know-how and product in service makes Kop-Flex the experts. So for coupling quality and variety, look to the leader. Look to Kop-Flex.

The High Performance Diaphragm Coupling

- Heat treated alloy parts
- Field replaceable, flexible elements
- Developed under a patented Kop-Flex design

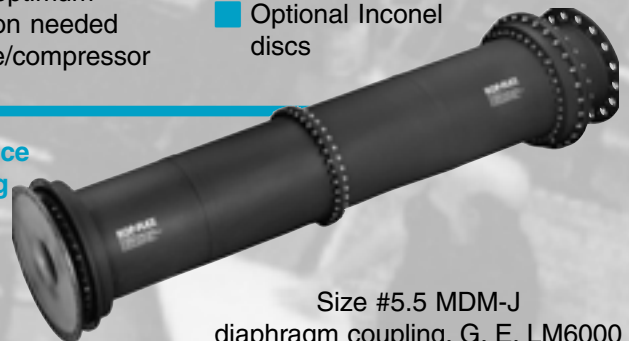

Size #5.5 MDM-J diaphragm coupling. G. E. LM6000 gas turbine. 60,000 HP @ 3600 RPM. Because of its patented design concept, this coupling offers the greatest flexibility of large angular and axial capability.

*Koplon is a trademark and/or a trade name of E. I. du Pont de Nemours and Company. This trade name, trademark and/or registered trademark is used herein for product comparison purposes only, is the property of its respective owner and is not owned or controlled by Emerson Power Transmission Corporation. Emerson Power Transmission does not represent or warrant the accuracy of this document.

KOP-FLEX®

Unparalleled Technology Leadership

Technology leadership can only be maintained through a commitment to highly skilled resources. Kop-Flex employs the largest engineering staff in the industry, which enables rapid new product development. An emphasis on engineering expertise stands behind the Kop-Flex tradition of custom product design and application for our customers.

Kop-Flex engineers are supported with an in-house R&D lab containing an extensive array of test equipment and dedicated R&D engineers, computer aided design (CAD) systems, finite element analysis (FEA), 3-D modeling and other technical tools to respond quickly to customer requests and field installation requirements.

Continuing Innovation

Continuing in the spirit of frequent innovation, Kop-Flex recently introduced:

- Patented urethane-based elastomer coupling — Odyssey
- Patented precision torque Powerlign measurement system with accuracy to within $\pm 1\%$
- Patented CGG™ ground gear spindle used in high load, high impact steel mills
- Patented diaphragm coupling — all metal design with no welds

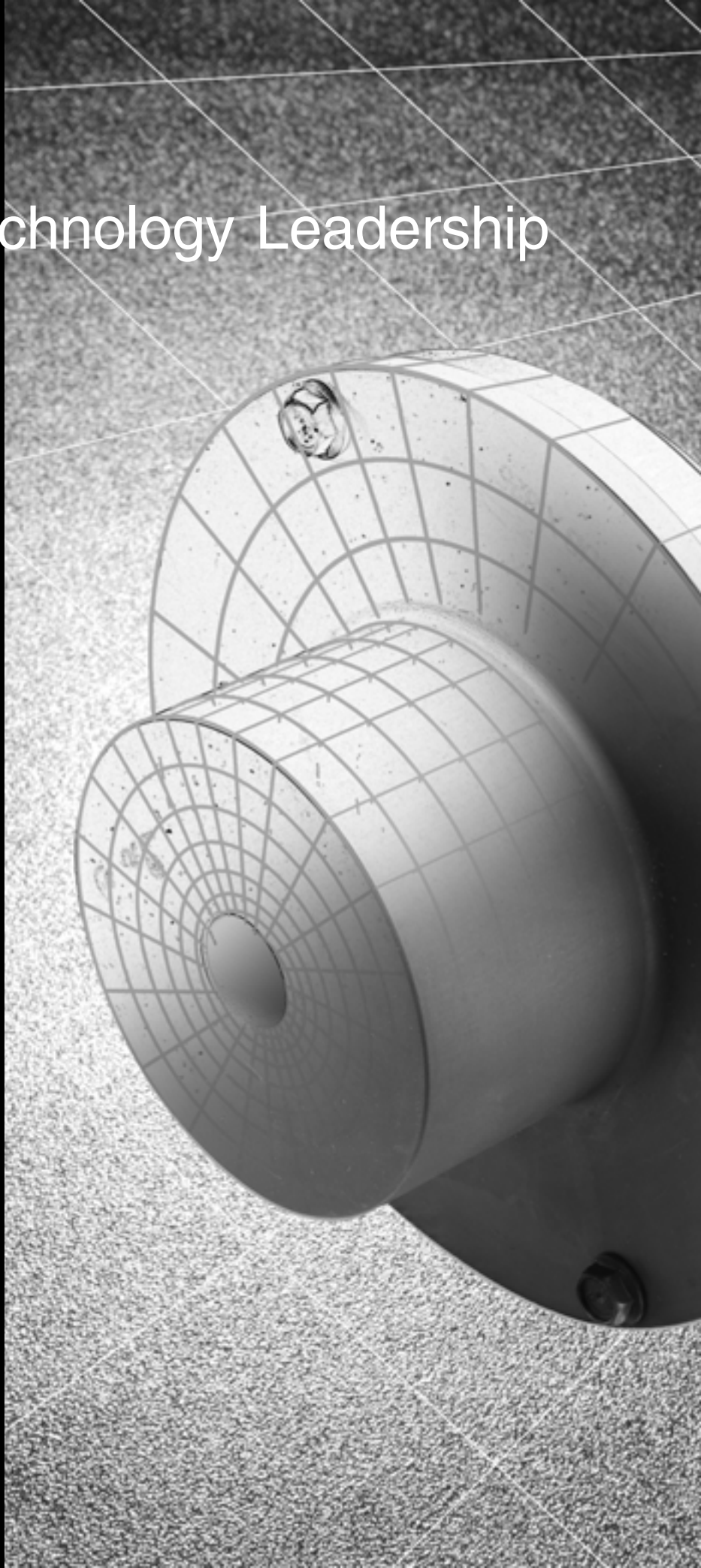



Unmatched Service and Support

Kop-Flex consistently responds to customer needs for reliable, maintenance-friendly products by demonstrating an attention to precision and detail that is highly valued in the marketplace. Kop-Flex also has the market's largest stock of critical couplings for overnight delivery to support a company-wide priority on helping customers maintain uptime.

Kop-Flex practices an extensive inspection process and can repair or refurbish couplings – including designs produced by other manufacturers. Customer risk is further reduced with the full Kop-Flex warranty.

All sales are made on our STANDARD TERMS AND CONDITIONS OF SALE in effect at the time a customer's order is accepted. The current Terms and Conditions are set forth below:

STANDARD TERMS AND CONDITIONS OF SALE (August 15, 2001)

These Terms and Conditions, the attendant quotation or acknowledgment and all documents incorporated by specific reference therein, will be the complete and exclusive statement of the terms of the agreement governing the sale of goods ("Goods") by **Emerson Power Transmission Corporation** and its divisions and subsidiaries ("Seller") to Customer ("Buyer"). Buyer's acceptance of the Goods will manifest Buyer's assent to these Terms and Conditions. If these Terms and Conditions differ in any way from the terms and conditions of Buyer's order, or other documentation, this document will be construed as a counteroffer and will not be deemed an acceptance of Buyer's terms and conditions which conflict herewith.

1. **PRICES:** Unless otherwise specified in writing by Seller, Seller's price for the goods shall remain in effect for thirty (30) days after the date of Seller's quotation or acknowledgment of Buyer's order for the Goods, whichever occurs first, provided an unconditional, complete authorization for the immediate shipment of the Goods is received and accepted by Seller within such time period. If such authorization is not received by Seller within such thirty (30) day period, Seller shall have the right to change the price for the Good to Seller's price for the Goods at the time of shipment.

2. **TAXES:** Any tax or governmental charge or increase in same hereafter becoming effective increasing the cost to Seller of producing, selling or delivering the Goods or of procuring material used therein, and any tax now in effect or increase in same payable by the Seller because of the manufacture, sale or delivery of the Goods, may at Seller's option, be added to the price.

3. **TERMS OF PAYMENT:** Subject to the approval of Seller's Credit Department, terms are net thirty (30) days from date of Seller's invoice in U.S. currency. If any payment owed to Seller is not paid when due, it shall bear interest, at a rate to be determined by Seller, which shall not exceed the maximum rate permitted by law, from the date on which it is due until it is paid. Seller shall have the right, among other remedies, either to terminate the Agreement or to suspend further performance under this and/or other agreements with Buyer in the event Buyer fails to make any payment when due. Buyer shall be liable for all expenses, including attorneys' fees, relating to the collection of past due amounts.

4. **SHIPMENT AND DELIVERY:** Shipments are made F.O.B. Seller's shipping point. Any claims for shortages or damages suffered in transit shall be submitted by the Buyer directly to the carrier. While Seller will use all reasonable commercial efforts to maintain the delivery date acknowledged or quoted by Seller, all shipping dates are approximate. Seller reserves the right to make partial shipments and to segregate "specials" and made-to-order Goods from normal stock Goods. Seller shall not be bound to tender delivery of any Goods for which Buyer has not provided shipping instructions.

5. **QUANTITY:** Buyer agrees to accept overruns of up to ten percent (10%) of the order on "made-to-order" Goods, including parts. Any such additional items shall be priced at the price per item charged for the specific quantity ordered.

6. **LIMITED WARRANTY:** Subject to the limitations of Section 7, Seller warrants that the Goods will be free from defects in material and workmanship under normal use, service and maintenance for a period of one year (unless otherwise specified by Seller in writing) from the date of shipment of the Goods by Seller. **THIS IS THE SOLE AND EXCLUSIVE WARRANTY GIVEN BY SELLER WITH RESPECT TO THE GOODS AND IS IN LIEU OF AND EXCLUDES ALL OTHER WARRANTIES, EXPRESS OR IMPLIED, ARISING BY OPERATION OF LAW OR OTHERWISE, INCLUDING WITHOUT LIMITATION, MERCHANTABILITY OR FITNESS FOR A PARTICULAR PURPOSE WHETHER OR NOT THE PURPOSE OR USE HAS BEEN DISCLOSED TO SELLER IN SPECIFICATIONS, DRAWINGS OR OTHERWISE, AND WHETHER OR NOT SELLER'S PRODUCTS ARE SPECIFICALLY DESIGNED AND/OR MANUFACTURED BY SELLER FOR BUYER'S USE OR PURPOSE.**

This warranty does not extend to any losses or damages due to misuse, accident, abuse, neglect, normal wear and tear, unauthorized modification or alteration, use beyond rated capacity, or improper installation, maintenance or application. To the extent that Buyer or its agents has supplied specifications, information, representation of operating conditions or other data to Seller in the selection or design of the Goods and the preparation of Seller's quotation, and in the event that actual operating conditions or other conditions differ from those represented by Buyer, any warranties or other provisions contained herein which are affected by such conditions shall be null and void. If within thirty (30) days after Buyer's discovery of any warranty defects within the warranty period, Buyer notifies Seller thereof in writing, Seller shall, at its option, repair or replace F.O.B. point of manufacture, or refund the purchase price for that portion of the goods found by Seller to be defective. Failure by Buyer to give such written notice within the applicable time period shall be deemed an absolute and unconditional waiver of Buyer's claim for such defects. Goods repaired or replaced during the warranty period shall be covered by the foregoing warranty for the remainder of the original warranty period or ninety (90) days, whichever is longer. Buyer assumes all other responsibility for any loss, damage, or injury to persons or property arising out of, connected with, or resulting from the use of Goods, either alone or in combination with other products/components.

SECTIONS 6 AND 7 APPLY TO ANY ENTITY OR PERSON WHO MAY BUY, ACQUIRE OR USE SELLER'S GOODS, INCLUDING ANY ENTITY OR PERSON WHO BUYS THE GOODS FROM SELLER'S DISTRIBUTOR AND SUCH ENTITY OR PERSON SHALL BE BOUND BY THE LIMITATIONS THEREIN.

7. **LIMITATION OF REMEDY AND LIABILITY: THE SOLE AND EXCLUSIVE REMEDY FOR BREACH OF ANY WARRANTY HEREUNDER (OTHER THAN THE WARRANTY PROVIDED UNDER SECTION 13) SHALL BE LIMITED TO REPAIR, REPLACEMENT OR REFUND OF THE PURCHASE PRICE UNDER SECTION 6. SELLER SHALL NOT BE LIABLE FOR DAMAGES CAUSED BY DELAY IN PERFORMANCE AND IN NO EVENT, REGARDLESS OF THE FORM OF THE CLAIM OR CAUSE OF ACTION (WHETHER BASED IN CONTRACT, INFRINGEMENT, NEGLIGENCE, STRICT LIABILITY, OTHER TORT OR OTHERWISE), SHALL SELLER'S LIABILITY TO BUYER AND/OR ITS CUSTOMERS EXCEED THE PRICE TO BUYER OF THE SPECIFIC GOODS PROVIDED BY SELLER GIVING RISE TO THE CLAIM OR CAUSE OF ACTION. BUYER AGREES THAT IN NO EVENT SHALL SELLER'S LIABILITY TO BUYER AND/OR ITS CUSTOMERS EXTEND TO INCLUDE INCIDENTAL, CONSEQUENTIAL OR PUNITIVE DAMAGES. THE TERM "CONSEQUENTIAL DAMAGES" SHALL INCLUDE, BUT NOT BE LIMITED TO, LOSS OF ANTICIPATED PROFITS, LOSS OF USE, LOSS OF REVENUE, COST OF CAPITAL AND DAMAGE OR LOSS OF OTHER PROPERTY OR EQUIPMENT.**

It is expressly understood that any technical advice furnished by Seller with respect to

the use of the Goods is given without charge, and Seller assumes no obligation or liability for the advice given, or results obtained, all such advice being given and accepted at Buyer's risk.

GOODS AND/OR SERVICES SOLD HEREUNDER ARE NOT FOR USE IN ANY NUCLEAR AND RELATED APPLICATIONS. Buyer accepts goods and/or services with the foregoing understanding, agrees to communicate the same in writing to any subsequent purchaser or users and to defend, indemnify and hold harmless Seller from any claims, losses, suits, judgments and damages, including incidental and consequential damages, arising from such use, whether the cause of action be based in tort, contract or otherwise, including allegations that the Seller's liability is based on negligence or strict liability.

8. **EXCUSE OF PERFORMANCE:** Seller shall not be liable for delays in performance or for non-performance due to acts of God, acts of Buyer, war, riot, fire, flood, other severe weather, sabotage, or epidemics; strikes or labor disturbances; governmental requests, restrictions, laws, regulations, orders or actions; unavailability of or delays in transportation; default of suppliers; or unforeseen circumstances or any events or causes beyond Seller's reasonable control. Deliveries may be suspended for an appropriate period of time as a result of the foregoing. If Seller determines that its ability to supply the total demand for the Goods, or to obtain material used directly or indirectly in the manufacture of the Goods, is hindered, limited or made impracticable due to causes addressed in this Section 8, Seller may allocate its available supply of the Goods or such material (without obligation to acquire other supplies of any such Goods or material) among itself and its purchasers on such basis as Seller determines to be equitable without liability for any failure of performance which may result therefrom. Deliveries suspended or not made by reason of this section may be canceled by Seller upon notice to Buyer without liability, but the balance of the agreement shall otherwise remain unaffected.

9. **CANCELLATION:** The Buyer may cancel orders only upon written notice and upon payment to Seller of cancellation charges which include, among other things, all costs and expenses incurred and commitments made by the Seller and a reasonable profit thereon.

10. **CHANGES:** Buyer may request changes or additions to the Goods consistent with Seller's specifications and criteria. In the event such changes or additions are accepted by Seller, Seller may revise the price and delivery schedule. Seller reserves the right to change designs and specifications for the Goods without prior notice to Buyer, except with respect to Goods being made-to-order for Buyer.

11. **TOOLING:** Tool, die, and pattern charges, if any, are in addition to the price of the Goods and are due and payable upon completion of the tooling. All such tools, dies and patterns shall be and remain the property of Seller. Charges for tools, dies, and patterns do not convey to Buyer, title, ownership interests in, or rights to possession or removal, nor prevent their use by Seller for other purchasers, except as otherwise expressly provided by Seller and Buyer in writing with reference to this provision.

12. **ASSIGNMENT:** Buyer shall not assign its rights or delegate its duties hereunder or any interest therein or any rights hereunder without the prior written consent of the Seller, and any such assignment, without such consent, shall be void.

13. **PATENTS AND COPYRIGHTS:** Subject to Section 7, Seller warrants that the Goods sold, except as are made specifically for Buyer according to Buyer's specifications, do not infringe any valid U.S. patent or copyright in existence as of the date of delivery. This warranty is given upon the condition that Buyer promptly notify Seller of any claim or suit involving Buyer in which such infringement is alleged, and that Buyer cooperate fully with Seller and permit Seller to control completely the defense or compromise of any such allegation of infringement. Seller's warranty as to use only applies to infringements arising solely out of the inherent operation (i) of such Goods, or (ii) of any combination of Goods in a system designed by Seller. In the event such Goods, singly or in combination, are held to infringe a U.S. patent or copyright in such suit, and the use of such Goods is enjoined, or in the case of a compromise by Seller, Seller shall have the right, at its option and expense, to procure for Buyer the right to continue using such Goods, or replace them with non-infringing Goods; or modify same to become non-infringing; or grant Buyer a credit for the depreciated value of such Goods and accept return of them.

14. **MISCELLANEOUS:** These terms and conditions set forth the entire understanding and agreement between Seller and Buyer, and supersede all other communications, negotiations and prior oral or written statements regarding the subject matter of these terms and conditions. No change, modification, rescission, discharge, abandonment, or waiver of these terms and conditions of Sale shall be binding upon the Seller unless made in writing and signed on its behalf by an officer of the Seller. No conditions, usage or trade, course of dealing or performance, understanding or agreement purporting to modify, vary, explain, or supplement these Terms and Conditions shall be binding unless hereafter made in writing and signed by the party to be bound, and no modification shall be affected by the acceptance of purchase orders or shipping instruction forms containing terms at variance with or in addition to those set forth herein. Any such modifications or additional terms are specifically rejected by Seller. No waiver by Seller with respect to any breach or default or any right or remedy and no course of dealing, shall be deemed to constitute a continuing waiver of any other breach or default or of any other right or remedy, unless such waiver be expressed in writing and signed by the party to be bound. Seller is not responsible for typographical or clerical errors made in any quotation, orders or publications. All such errors are subject to correction. The validity, performance, and all other matters relating to the interpretation and effect of this contract shall be governed by the law of the state of New York. The United Nations Convention on the International Sale of Goods shall not apply to any transaction hereunder.



Connect at
www.emerson-ept.com to
receive:

- Cost savings through electronic services
- Engineering efficiencies via online technical support
- Integrated site for integrated solutions across seven major brands

or www.kopflex.com for
engineered couplings
designed to order.

Browning[®]

KOP-FLEX[®]

McGILL[®]

Morse[®]

ROLLWAY[®]

SEALMASTER[®]



Our Web Site Provides a Wide Range of Efficient eBusiness Tools

User-friendly site provides comprehensive data on demand.

Product information is readily available to all visitors and registrants 24-7.

- Corporate overview
- All product families and brands
- Find a distributor
- Literature request forms

EDGE[®] Online provides you with technical information and product selection capabilities.

Also available -- around-the-clock, electronic tools that provide for efficient drive design and product selection

- **eCatalog** — an interactive, robust electronic “database” with over 100,000 part numbers searchable by part number or general description providing features and benefits of each product line
- **Product Selection** — selection tools with extensive engineering efficiency benefits
- **Smart Interchange** — a dynamic tool that provides the user with an intelligent interchange for competitive parts
- **CAD** — an online service that allows users to view and upload a 2D or 3D CAD template drawing in a number of customer-compatible formats to be integrated into your drawings
- **Media Library** — digital (PDF) version of paper catalogs, documents and downloadable installation and maintenance instructions
- **Engineered Solutions** — a quick and easy way for engineers to communicate special application information



Helical Speed Reducers & Gearmotors



SEALMASTER

Mounted Ball Bearings

Emerson Power Transmission Customer Service

Telephone 1-800-626-2120

Fax 1-800-262-3292

Emerson Power Transmission

Maysville, KY 41056

Telephone 606-564-2011

Fax 606-564-2052

Emerson Power Transmission

7120 New Buffington Rd.

P.O. Box 728

Florence, KY 41022

Telephone 859-342-7900

Fax 859-342-5652

Emerson Power Transmission – West

3553 Placentia Ct.

Chino, CA 91710

Telephone 909-591-9561

Fax 909-628-1983

Emerson Power Transmission – Export

7120 New Buffington Rd.

Florence, KY 41042

Telephone 859-727-5273

Fax 859-727-0721

Emerson Power Transmission – Canada

16 Main Street

Unionville, ONT L3R 2E4

Telephone 905-294-9330

1-800-268-4149

Fax 1-800-668-9005

Kop-Flex, Inc.

P. O. Box 1696

Baltimore, MD 21203

Telephone Plant 410-768-2000

Fax 410-787-8424

www.kopflex.com

Kop-Flex Canada, Ltd.

19 Meteor Drive

Rexdale, ONT M9W 1A3

Telephone 416-675-7144

Fax 416-675-6764

McGill Manufacturing Co., Inc.

909 North Lafayette St.

Valparaiso, IN 46383

Aerospace Bearings Telephone 219-465-2200

Aerospace Bearings Fax 219-465-2290



Morse

Clutches



Browning

Shaft Mount Reducers



SEALMASTER

Mounted Roller Bearings



ROLLWAY

Roller Bearings



Browning

V-Belt Drives



Morse

Chain



KOP-FLEX

Couplings



EMERSON

Conveyor Pulleys



Morse

Worm Gearing



McGILL

Precision Bearings

Catalog KHP-04

Form #8622 • Revised 10/04 • 20M • Printed in U.S.A.

Application Considerations

The proper selection and application of power transmission products and components, including the related area of product safety, is the responsibility of the customer. Operating and performance requirements and potential associated issues will vary appreciably depending upon the use and application of such products and components. The scope of the technical and application information included in this publication is necessarily limited. Unusual operating environments and conditions, lubrication requirements, loading supports, and other factors can materially affect the application and operating results of the products and components and the customer should carefully review its requirements. Any technical advice or review furnished by Emerson Power Transmission Corporation and its divisions with respect to the use of products and components is given in good faith and without charge, and Emerson assumes no obligation or liability for the advice given, or results obtained, all such advice and review being given and accepted at customer's risk.

For a copy of our Standard Terms and Conditions of Sale, Disclaimers of Warranty, Limitation of Liability and Remedy, please contact Emerson Power Transmission Customer Service at 1-800-626-2120. These terms and conditions of sale, disclaimers and limitations of liability apply to any person who may buy, acquire or use an Emerson Power Transmission Corporation product referred to herein, including any person who buys from a licensed distributor of these branded products.

www.emerson-ept.com