

KOP-GRID®

Tapered Grid Couplings

Interchangeable
with other Tapered
Grid Couplings

Tapered,
Shot Peened Grids
Quick, Easy Installation
Low Maintenance

For:
Petrochemical
and Refining
Material Handling
Pulp and Paper
Food and Textile
General Purpose

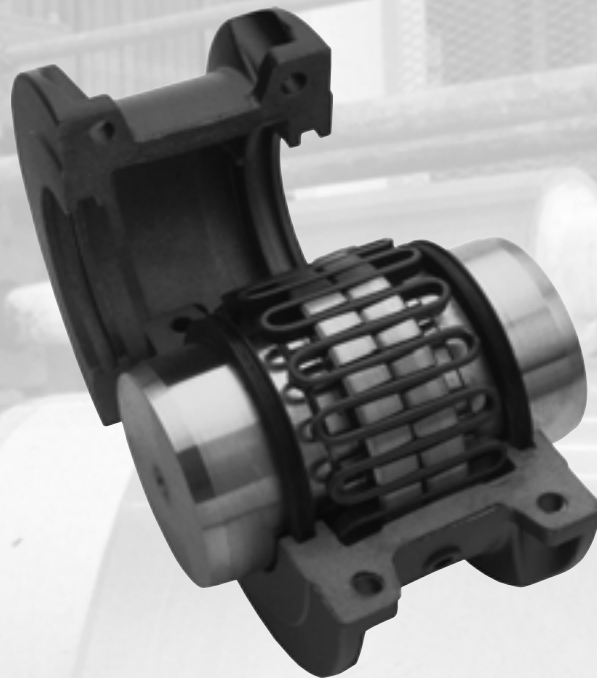

Index:

	Page
HOW TO ORDER	215, 218
Technical Advantages	212 - 213
Service Factors	214
Interchange Chart	215
Selection Procedure	215
T10 and T20 Standard Couplings	216 - 218
Engineering Data	219
T31 Full Spacer Coupling	220 - 221
T35 Half Spacer Coupling	222 - 223



Visit www.kopflex.com



Torsional Damping

The grid design functions as a resilient coupling by damping torsional vibration and cushioning shock loads, resulting in reduced vibration at the output end of the coupling. Peak loading is reduced, for smooth torque transmission, to help protect connected equipment from potentially damaging vibratory loads.

Overload Protection

A second function of the grid design is that it can act much like a protective overload shear device. During an extreme overload, the grid can shear, reducing the possibility of damage to expensive machinery and equipment.

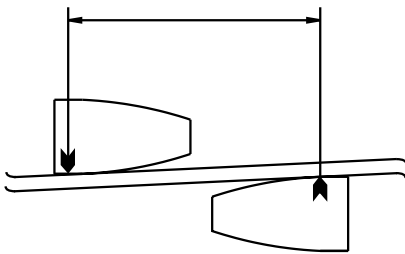

Light Load

The outer edges of the grid contact the hub tapered teeth for light loads, leaving a long span to bear the load variations and still compensate for misalignment.

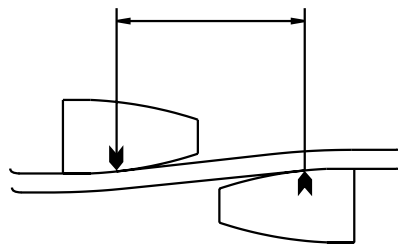

Normal Load

The grid is free to flex and dampen shock loads, even as the load increases. The span between the support ends shortens with increasing load, however the grid is still free to flex, cushioning shock and compensating for misalignment.

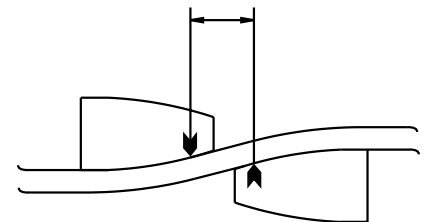

Shock Load

The KOP-GRID® coupling when under extreme loads, transmits the full load directly to driven equipment with the entire grid in full contact with the hub tapered teeth. The coupling is flexible within its rated capacity.

KOP-GRID® tapered grid couplings are your best choice to protect your investment in expensive driving and driven equipment from misalignment, shock loads and vibration, while accommodating reasonable shaft end float.

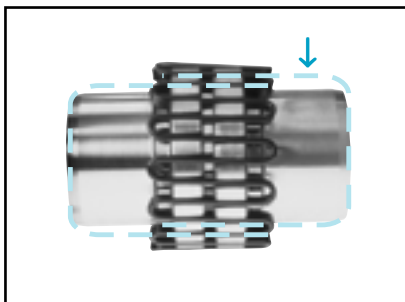

Offset (Parallel)

Movement of the grid in the hub grooves accommodates parallel misalignment while dampening shock and vibration.

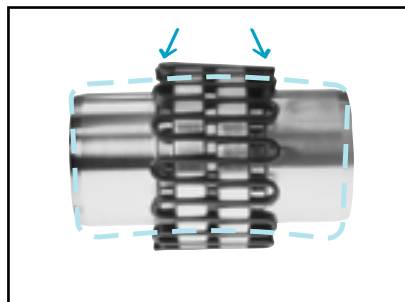

Angular

With angular misalignment, the grid/groove design permits a rocking and sliding action of grid and hubs without loss of power through the resilient grid.

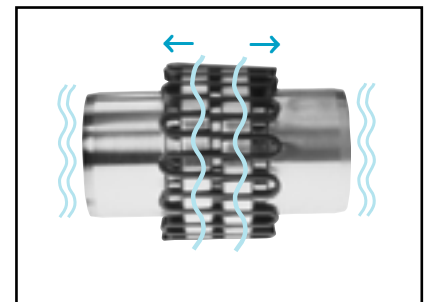

End Float (Axial)

End float is permitted for both driving and driven shafts because the grid slides freely in the lubricated grooves.



T10 with Horizontal Split Covers

Suited for multipurpose industrial applications

- Typical Applications:
 - Pulp Processing Machinery
 - Agitators and Aerators
 - Wood Grinders, Chippers
 - Conveyors and Crushers
 - Steel and Aluminum shaping
 - Textile and Food Machinery
- Interchangeable with other tapered grid couplings
- Horizontally split, aluminum alloy cover
- Easy installation and access to tapered grids
- Easy assembly in confined spaces
- Absorbs moderate shock and vibratory loads. Torsionally flexible
- Suitable for reversing service
- Socket head capscrews and self-locking nuts
- Steel hubs — straight bores or standard bushings



T20 with Vertical Split Covers

Designed for higher speed applications

- Typical Applications:
 - Food and Grain Process Equipment
 - Chemical Process Machinery
 - Screw Compressors and Vacuum Pumps
 - Fans, Blowers and Dryers
 - Gearbox Input Shafts
- Interchangeable with other tapered grid couplings
- Vertically split, corrosion resistant steel covers. Grade 8 hex head fasteners
- Torsionally flexible
- Steel hubs — straight bores or standard bushings



T31 Full Spacer

For general purpose, process pump applications

- Typical Applications:
 - Centrifugal Pumps such as: Stock and Chemical Process
 - Fish and Slurry Pumps
 - Petrochemical Process Lines
 - Municipal and Wastewater Pumps
 - Descaling and Pulp Pumps
- Interchangeable with other tapered grid couplings
- Full spacer version for process pumps
- Drop-out center spacer section for easy pump & equipment maintenance
- Horizontally split, aluminum alloy cover
- Standard shaft separations available from stock. Large bore capacity shaft hubs
- Grade 8 hex head shaft/spacer hub fasteners



T35 Half Spacer

For applications requiring moderate shaft separations

- Typical Applications:
 - Fans, Blowers and Dryers
 - Centrifugal Process Pumps
 - Vacuum Pumps
 - Crushers and Pulverizers
- Interchangeable with other tapered grid couplings
- Half spacer style for shorter shaft separations
- Uses standard, interchangeable components
- Horizontally split, aluminum alloy cover
- Steel hubs — straight bores or standard bushings
- Easily installed and maintained

Values listed are intended only as a general guide, and are typical of usual service requirements. For systems which frequently utilize the peak torque capability of the power source, verify that the magnitude of this peak torque does not exceed the 1.0 Service Factor Rating of the coupling selected. Applications which involve extreme repetitive shock or high-energy load absorption characteristics should be referred — with full particulars — to KOP-FLEX.

Values contained in the table are to be applied to smooth power sources such as electric motors and steam turbines. For drives involving internal combustion engines of four or five cylinders, add 1.0 to the values listed; for six or more cylinders, add 0.5 to the values listed. For systems utilizing AC or DC Mill Motors as the prime mover, refer to Note (1).

CAUTION All peoplemoving applications must be referred to engineering.

Application	Typical Service Factor
AGITATORS	
Pure Liquids	1.0
Liquids & Solids	1.25
Liquids — Variable Density	1.25
BLOWERS	
Centrifugal	1.0
Lobe	1.5
Vane	1.25
BRIQUETTE MACHINES	2.0
CAR PULLERS — Intermittent Duty	1.5
COMPRESSORS	
Centrifugal	1.0
Centriaxial	1.25
Lobe	1.5
Reciprocating — Multi-Cylinder	2.0
CONVEYORS — LIGHT DUTY	
UNIFORMLY FED	
Apron, Bucket, Chain, Flight, Screw	1.25
Assembly, Belt	1.0
Oven	1.5
CONVEYORS — HEAVY DUTY	
NOT UNIFORMLY FED	
Apron, Bucket, Chain, Flight, Oven	1.5
Assembly, Belt	1.25
Reciprocating, Shaker	2.5
CRANES AND HOISTS (NOTE 1 and 2)	
Main hoists, Reversing	2.5
Skip Hoists, Trolley & Bridge Drives	2.0
Slope	2.0
CRUSHERS	
Ore, Stone	3.0
DREDGES	
Cable Reels	1.75
Conveyors	1.5
Cutter Head Jig Drives	2.5
Maneuvering Winches	1.75
Pumps	1.75
Screen Drives	1.75
Stackers	1.75
Utility Winches	1.5
ELEVATORS (NOTE 2)	
Bucket	1.75
Centrifugal & Gravity Discharge	1.5
Escalators	1.5
Freight	2.5
FANS	
Centrifugal	1.0
Cooling Towers	1.5
Forced Draft	1.5
Induced Draft without Damper Control	2.0
FEEDERS	
Apron, Belt, Disc, Screw	1.25
Reciprocating	2.5

Application	Typical Service Factor
GENERATORS —	
(Not Welding)	1.0
HAMMER MILLS	2.0
LAUNDRY WASHERS —	
Reversing	2.0
LAUNDRY TUMBLERS	2.0
LINE SHAFT	1.5
LUMBER INDUSTRY	
Barkers — Drum Type	2.0
Edger Feed	2.0
Live Rolls	2.0
Log Haul — Incline	2.0
Log Haul — Well type	2.0
Off Bearing Rolls	2.0
Planer Feed Chains	1.75
Planer Floor Chains	1.75
Planer Tilting Hoist	1.75
Slab Conveyor	1.5
Sorting Table	1.5
Trimmer Feed	1.75
MARINE PROPULSION	
Main Drives	2.0
MACHINE TOOLS	
Bending Roll	2.0
Plate Planer	1.5
Punch Press — Gear Driven	2.0
Tapping Machines	2.5
Other Machine Tools	
Main Drives	1.5
Auxiliary Drives	1.25
METAL MILLS	
Draw Bench — Carriage	2.0
Draw Bench — Main Drive	2.0
Forming Machines	2.0
Slitters	1.5
Table Conveyors	
Non-Reversing	2.25
Reversing	2.5
Wire Drawing & Flattening Machine	2.0
Wire Winding Machine	1.75
METAL ROLLING MILLS (NOTE 1)	
Blooming Mills	*
Coilers, hot mill	2.0
Coilers, cold mill	1.25
Cold Mills	2.0
Cooling Beds	1.75
Door Openers	2.0
Draw Benches	2.0
Edger Drives	1.75
Feed Rolls, Reversing Mills	3.5
Furnace Pushers	2.5
Hot Mills	3.0
Ingot Cars	2.5
Kick-outs	2.5
Manipulators	3.0
Merchant Mills	3.0
Piercers	3.0
Pusher Rams	2.5
Reel Drives	1.75
Reel Drums	2.0
Reelers	3.0
Rod and Bar Mills	1.5
Roughing Mill Delivery Table	3.0
Runout Tables	
Reversing	3.0
Non-Reversing	2.0
Saws, hot & cold	2.5
Screwdown Drives	3.0
Skelp Mills	3.0
Slitters	3.0
Slabbing Mills	3.0
Soaking Pit Cover Drives	3.0
Straighteners	2.5
Tables, transfer & runout	2.0
Thrust Block	3.0
Traction Drive	3.0
Tube Conveyor Rolls	2.5
Unscramblers	2.5
Wire Drawing	1.5
MILLS, ROTARY TYPE	
Ball	2.25
Dryers & Coolers	2.0
Hammer	1.75
Kilns	2.0

Application	Typical Service Factor
Pebble & Rod	2.0
Pug	1.75
Tumbling Barrels	2.0
MIXERS	
Concrete Mixers	1.75
Drum Type	1.5
OIL INDUSTRY	
Chillers	1.25
Paraffin Filter Press	1.75
PAPER MILLS	
Barker Auxiliaries, Hydraulic	2.0
Barker, Mechanical	2.0
Barking Drum Spur Gear Only	2.25
Beater & Pulper	1.75
Bleacher	1.0
Calenders	2.0
Chippers	2.5
Coaters	1.0
Converting Machines, except Cutters, Platers	1.5
Couch Roll	1.75
Cutters, Platers	2.0
Cylinders	1.75
Disc Refiners	1.75
Dryers	1.75
Felt Stretcher	1.25
Felt Whipper	2.0
Jords	1.75
Line Shaft	1.5
Log Haul	2.0
Pulp Grinder	1.75
Press Roll	2.0
Reel	1.5
Stock Chests	1.5
Suction Roll	1.75
Washers & Thickeners	1.5
Winders	1.5
PRINTING PRESSES	1.5
PULLERS — Barge Haul	2.0
PUMPS	
Centrifugal	1.0
Boiler Feed	1.5
Reciprocating	
Single Acting	
1 or 2 Cylinders	2.25
3 or more Cylinders	1.75
Double Acting	2.0
Rotary, Gear, Lobe, Vane	1.5
RUBBER INDUSTRY	
Mixer — Banbury	2.5
Rubber Calendar	2.0
Rubber Mill (2 or more)	2.25
Sheeter	2.0
Tire Building Machines	2.5
Tire & Tube Press Openers	1.0
Tubers & Strainers	2.0
SCREENS	
Air Washing	1.0
Grizzly	2.0
Rotary — Stone or Gravel	1.5
Traveling Water Intake	1.25
Vibrating	2.5
SEWAGE DISPOSAL EQUIPMENT	
Bar Screens	1.25
Chemical Feeders	1.25
Collectors, Circuline or Straightline	1.25
Dewatering Screens	1.25
Grit Collectors	1.25
Scum Breakers	1.25
Slow or Rapid Mixers	1.25
Sludge Collectors	1.25
Thickeners	1.25
Vacuum Filters	1.25
STEERING GEAR	1.0
STOKERS	1.0
WINCH	1.5
WINDLASS	1.75

* Refer to KOP-FLEX

NOTES

- (1) Maximum Torque at the coupling must not exceed Rated Torque of the coupling.
- (2) Check local and industrial safety codes.

Selection Procedure

1. Coupling Type:

Select the appropriate KOP-GRID® coupling type for your application. See page 213 for coupling types.

2. Coupling Size:

Step 1: Determine the proper service factor from page 214.

Step 2: Calculate the required HP/100 RPM, using the HP rating of the drive and the coupling speed (RPM) as shown below:

$$\frac{\text{HP} \times \text{SERVICE FACTOR} \times 100}{\text{RPM}} = \text{HP/100 RPM}$$

Step 3: Select the coupling size having a rating sufficient to handle the required HP/100 RPM at the appropriate service factor.

Step 4: Verify that the actual coupling speed (RPM) is equal to or less than the maximum allowable speed rating of the coupling.

Step 5: Verify that the maximum bore of the coupling selected is equal to or larger than either of the equipment shafts.

Step 6: Check the overall dimensions to ensure coupling will not interfere with the coupling guard, piping, or the equipment housings and that it will fit the required shaft separation.

KOP-GRID® Coupling Interchange Guide

KOP-GRID® couplings are interchangeable with other tapered grid couplings, component by component • hubs, grids, seals, and cover assembly

KOP-GRID	FALK*	DODGE*	LOVEJOY*
1020T	1020T	1020T	2020
1030T	1030T	1030T	2030
1040T	1040T	1040T	2040
1050T	1050T	1050T	2050
1060T	1060T	1060T	2060
1070T	1070T	1070T	2070
1080T	1080T	1080T	2080
1090T	1090T	1090T	2090
1100T	1100T	1100T	2100
1110T	1110T	1110T	2110
1120T	1120T	1120T	2120
1130T	1130T	1130T	2130
1140T	1140T	1140T	2140

Coupling Types	KOP-GRID	FALK*	DODGE*	LOVEJOY*
Horizontally Split Cover	T10	T10	T10	H
Vertically Split Cover	T20	T20	T20	V
Spacer (Full) Coupling	T31	T31	T31	N / A
Half Spacer Coupling	T35	T35	T35	N / A

PART NUMBER EXPLANATION Complete Rough Bore Coupling

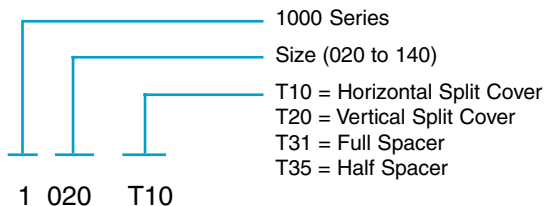

Coupling Parts

Description
HUB = Rough Bore Hub
HUBxBORE = Finished Bore Hub
HUBx(Bushing Size) = Hubs for Split Taper Bushing
GRID = Tapered Grid
T10 CGA = Cover and Grid Ass'y Horizontal
T20 CGA = Cover and Grid Ass'y Vertical
T10 Cover = Horizontal Split Cover
T20 Cover = Vertical Split Cover
T10 AK = Horizontal Cover Accessory Kit
T20 AK = Vertical Cover Accessory Kit
SHUB = Shaft Hub
SHUBx(Bushing Size) = Shaft Hub for Split Taper Bushing
SPHxxx = Distance Between Shaft Ends (x.xx)

ex. 1020 HUBx5/8

*DODGE is a trademark of Reliance Electric Company.

*FALK is a trademark of The Falk Corporation.

*LOVEJOY is a trademark of Lovejoy, Inc.

These trade names, trademarks and/or registered trademarks of others are used herein for product comparison purposes only, are the property of their respective owners and are not owned or controlled by Emerson Power Transmission Corporation (EPT). EPT does not represent or warrant the accuracy of this document.

T10 WITH HORIZONTAL SPLIT COVERS

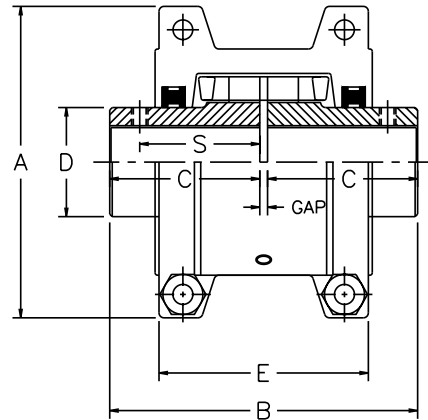
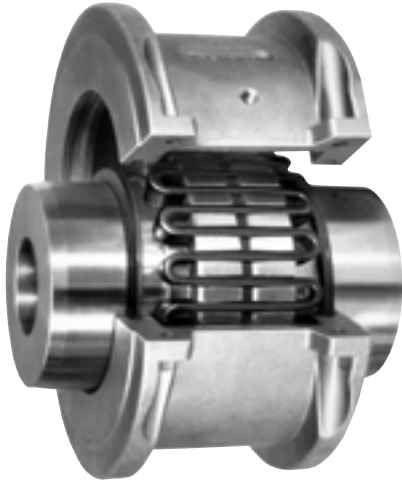

T20 WITH VERTICAL SPLIT COVERS

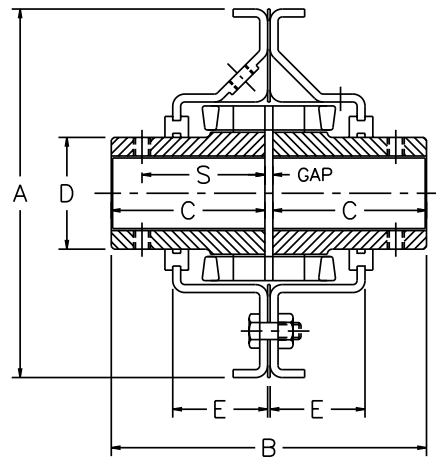

T10 & T20 WITH BROWNING® BRAND SPLIT TAPER™ BUSHING

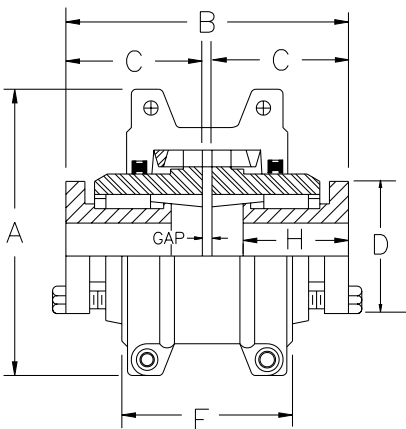

T10 W/BUSHINGS

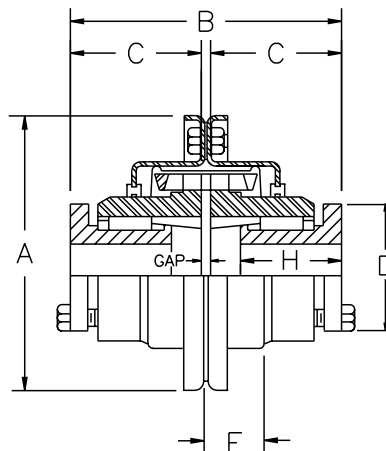

T20 W/BUSHINGS



Visit www.kopflex.com

Table No. 1 Specifications — KOP-GRID® T10 with Horizontal Split Covers

Coupling Size	HP per 100 RPM	Torque Rating (lb.-in.)	Maximum Speed RPM	Maximum Bore (Square Key)	Cplg. Wt. With No Bore - lb.	Dimensions - Inches						
						A	B	C	D	E	S	Gap
1020	0.68	422	4500	1.125	4.2	4.00	3.88	1.88	1.56	2.62	1.36	.125
1030	1.93	1200	4500	1.375	5.7	4.38	3.88	1.88	1.94	2.69	1.54	.125
1040	3.22	2000	4500	1.625	7.5	4.62	4.12	2.00	2.25	2.75	1.58	.125
1050	5.63	3500	4500	1.875	12	5.44	4.88	2.38	2.62	3.12	1.75	.125
1060	8.85	5500	4350	2.125	16	5.94	5.12	2.50	3.00	3.62	2.06	.125
1070	13	8000	4125	2.500	22	6.38	6.12	3.00	3.44	3.75	2.12	.125
1080	27	16500	3600	3.000	40	7.64	7.12	3.50	4.12	4.57	2.54	.125
1090	48	30000	3600	3.500	55	8.38	7.88	3.88	4.88	4.81	2.81	.125
1100	81	50500	2440	4.000	93	9.84	9.69	4.75	5.59	6.12	-	.188
1110	121	75000	2250	4.500	119	10.62	10.19	5.00	6.31	6.36	-	.188
1120	177	110000	2025	5.000	179	12.12	12.00	5.88	7.06	7.54	-	.250
1130	257	160000	1800	6.000	267	13.62	13.00	6.38	8.56	7.69	-	.250
1140	370	230000	1650	7.250	393	15.12	14.65	7.19	10.00	7.91	-	.250

Table No. 2 Specifications — KOP-GRID® T20 with Vertical Split Covers

Coupling Size	HP per 100 RPM	Torque Rating (lb.-in.)	Maximum Speed RPM	Maximum Bore (Square Key)	Cplg. Wt. With No Bore - lb.	Dimensions - Inches						
						A	B	C	D	E	S	Gap
1020	0.68	422	6000	1.125	4.3	4.38	3.88	1.88	1.56	0.95	1.36	.125
1030	1.93	1200	6000	1.375	5.7	4.75	3.88	1.88	1.94	0.98	1.54	.125
1040	3.22	2000	6000	1.625	7.4	5.06	4.12	2.00	2.25	1.00	1.58	.125
1050	5.63	3500	6000	1.875	12	5.81	4.88	2.38	2.62	1.22	1.75	.125
1060	8.85	5500	6000	2.125	16	6.38	5.12	2.50	3.00	1.28	2.06	.125
1070	13	8000	5500	2.500	23	6.81	6.12	3.00	3.44	1.33	2.12	.125
1080	27	16500	4750	3.000	39	7.88	7.12	3.50	4.12	1.75	2.54	.125
1090	48	30000	4000	3.500	56	9.12	7.88	3.88	4.88	1.88	2.81	.125
1100	81	50500	3250	4.000	93	10.50	9.69	4.75	5.59	2.36	-	.188
1110	121	75000	3000	4.500	120	11.25	10.19	5.00	6.31	2.53	-	.188
1120	177	110000	2700	5.000	180	12.56	12.00	5.88	7.06	2.88	-	.250
1130	257	160000	2400	6.000	270	14.88	13.00	6.38	8.56	2.96	-	.250
1140	370	230000	2200	7.250	397	16.38	14.65	7.19	10.00	3.08	-	.250

Table No. 3 Specifications — KOP-GRID® T10 & T20 Couplings for BROWNING® Brand SPLIT TAPER™ Bushings

Coupling Size	H.P. per 100 RPM	Torque Rating (lb.-in.)	Bushings	Bore Range	Wt. Less Bushing (lb.)	Dimensions - Inches								Gap
						A		B	C	D	E		H	
						T10 Cover	T20 Cover				T10 Cover	T20 Cover		
1040	1.98	1250	G	.375-1.0	6.3	4.62	5.06	4.38	1.94	2.00	2.75	1.00	1.00	.125
1050	4.19	2640	H	.375-1.5	10.0	5.44	5.81	4.88	2.19	2.50	3.12	1.25	1.25	.125
1060	8.71	5500	P1	.5-1.75	13.3	5.94	6.38	5.88	2.63	3.00	3.62	1.25	1.94	.125
1070	13	8000	P1	.5-1.75	18.7	6.38	6.86	5.88	2.63	3.00	3.75	1.38	1.94	.125
1080	26	16500	Q1	.75-2.688	30.6	7.64	7.88	7.19	3.25	4.13	4.56	1.75	2.50	.125
1090	33	20500	Q1	.75-2.688	44.6	8.38	9.12	7.44	3.38	4.13	4.81	1.88	2.50	.125
1100	65	40900	R1	1.125-3.75	70	9.88	10.50	9.00	4.12	5.38	6.12	2.38	2.88	.188
1110	65	40900	R1	1.125-3.75	94	10.62	11.25	9.25	4.25	5.38	6.36	2.50	2.88	.188
1120	127	79800	S1	1.688-4.25	140	12.12	12.56	11.13	5.06	6.38	7.55	3.00	4.38	.250
1130	254	160000	U0	3.25-5.50	199	13.62	14.88	11.56	5.19	8.38	7.69	3.00	4.94	.250
1140	297	187000	U0	3.25-5.50	294	15.12	16.38	11.19	5.31	8.38	7.92	3.12	4.94	.250

Note: See Table 1 and 2 for maximum speeds.

HOW TO ORDER T10 & T20 COUPLINGS

Table No. 4 KOP-GRID® Couplings — Hubs, Grid, Cover, Seal and Fastener Kits

Cplg. Size	Complete Rough® Bore Couplings		Hubs					T10 Horizontal			T20 Vertical		
	T10 Horizontal Split Cover	T20 Vertical Split Cover	Grid Hub No Bore	Finished Bore and Bored to Size	Grid Hub Bushed	Bush-ing	Tapered Grid Kit	Cover and Grid Assembly	Cover Kit	Accessory Kit	Cover and Grid Assembly	Cover Kit	Accessory Kit
1020	1020T10	1020T20	1020 HUB	1020 HUB x Bore	—	—	1020 GRID	1020T10 CGA	1020T10 COVER	1020T10 AK	1020T20 CGA	1020T20 COVER	1020T20 AK
1030	1030T10	1030T20	1030 HUB	1030 HUB x Bore	—	—	1030 GRID	1030T10 CGA	1030T10 COVER	1030T10 AK	1030T20 CGA	1030T20 COVER	1030T20 AK
1040	1040T10	1040T20	1040 HUB	1040 HUB x Bore	1040 HUBXG	G	1040 GRID	1040T10 CGA	1040T10 COVER	1040T10 AK	1040T20 CGA	1040T20 COVER	1040T20 AK
1050	1050T10	1050T20	1050 HUB	1050 HUB x Bore	1050 HUBXH	H	1050 GRID	1050T10 CGA	1050T10 COVER	1050T10 AK	1050T20 CGA	1050T20 COVER	1050T20 AK
1060	1060T10	1060T20	1060 HUB	1060 HUB x Bore	1060 HUBXP	P1	1060 GRID	1060T10 CGA	1060T10 COVER	1060T10 AK	1060T20 CGA	1060T20 COVER	1060T20 AK
1070	1070T10	1070T20	1070 HUB	1070 HUB x Bore	1070 HUBXP	P1	1070 GRID	1070T10 CGA	1070T10 COVER	1070T10 AK	1070T20 CGA	1070T20 COVER	1070T20 AK
1080	1080T10	1080T20	1080 HUB	1080 HUB x Bore	1080 HUBXQ	Q1	1080 GRID	1080T10 CGA	1080T10 COVER	1080T10 AK	1080T20 CGA	1080T20 COVER	1080T20 AK
1090	1090T10	1090T20	1090 HUB	1090 HUB x Bore	1090 HUBXQ	Q1	1090 GRID	1090T10 CGA	1090T10 COVER	1090T10 AK	1090T20 CGA	1090T20 COVER	1090T20 AK
1100	1100T10	1100T20	1100 HUB	1100 HUB x Bore	1100 HUBXR	R1	1100 GRID	1100T10 CGA	1100T10 COVER	1100T10 AK	1100T20 CGA	1100T20 COVER	1100T20 AK
1110	1110T10	1110T20	1110 HUB	1110 HUB x Bore	1110 HUBXR	R1	1110 GRID	1110T10 CGA	1110T10 COVER	1110T10 AK	1110T20 CGA	1110T20 COVER	1110T20 AK
1120	1120T10	1120T20	1120 HUB	1120 HUB x Bore	1120 HUBXS	S1	1120 GRID	1120T10 CGA	1120T10 COVER	1120T10 AK	1120T20 CGA	1120T20 COVER	1120T20 AK
1130	1130T10	1130T20	1130 HUB	1130 HUB x Bore	1130 HUBXU	U0	1130 GRID	1130T10 CGA	1130T10 COVER	1130T10 AK	1130T20 CGA	1130T20 COVER	1130T20 AK
1140	1140T10	1140T20	1140 HUB	1140 HUB x Bore	1140 HUBXU	U0	1140 GRID	1140T10 CGA	1140T10 COVER	1140T10 AK	1140T20 CGA	1140T20 COVER	1140T20 AK

- ① To order complete Rough Bore Couplings, specify by Part Number only, for example “1020T10”; Rough Bore Hubs, and T10 Cover and Grid Assembly is included.
- ② To order a Coupling with Finished Bore or Bored to Size Hubs, order two hubs, one Cover and Grid Assembly. Specify Hub Part Number x Bore Size, for example “1020HUBx5/8”. If the bore size indicated is shown in Table No. 4, above, then the hub is a Standard Finished Bore Hub; otherwise a Rough Bore Hub must be rebored.
- ③ To order a Coupling with Split Taper Bushings, order two Bushed Hubs and two appropriate Bushings, one Cover and Grid Assembly.
- ④ Cover Kits include Seal and Fastener Sets. The Assembly Kits shown are for REPLACEMENT ONLY.

Coupling Greases
 KOP-FLEX offers greases specifically designed for use in coupling applications. For proper lubrication and long service life, use KSG Standard Coupling Grease, or KHP High Performance Coupling Grease. See pages 204-206 for detailed specifications.

Table No. 5 Standard Clearance Bored Hubs with Set-Screws

Hub Part No.*	Standard Bores (Inches)																						
	1/2	5/8	3/4	7/8	1	1 1/8	1 1/4	1 3/8	1 1/2	1 5/8	1 3/4	1 7/8	2	2 1/8	2 1/4	2 3/8	2 1/2	2 5/8	2 3/4	2 7/8	3	3 3/8	
1020H	X	X	X	X	X	X																	
1030H		X	X	X	X	X	X	X															
1040H				X	X	X	X	X	X	X													
1050H						X	X	X	X	X	X												
1060H								X	X	X	X	X	X	X									
1070H										X	X	X	X	X	X								
1080H											X	X	X	X	X	X	X						
1090H												X	X	X	X	X	X	X	X	X	X	X	X

*Complete Hub Part Number by adding Bore Size. Other bores are available by boring Rough Bore Hubs.
 NOTE – Hub Numbers 1020 HUB through 1190 HUB have clearance fit bores with setscrew over Keyway.
 – Hub Numbers 1100 HUB through 1140 HUB have interference fit bores with no Setscrew.



Type T10 & T20 Grid Hub Bore Capacity with Square and Rectangular Keys ① ②

Size	For One Square Key			For One Rectangular Key					
	Max. Bore (in.)	Y = X		Max. Bore (in.)	Y = X		Y = W/2		
		W	X		W	X	W	X	
1020	1.125	.250	.125	1.187	.250	.093	1.250	.250	.062
1030	1.375	.312	.156	1.437	.375	.125	1.562	.375	.062
1040	1.625	.375	.187	1.750	.375	.125	1.750	.375	.062
1050	1.875	.500	.250	2.000	.500	.187	2.125	.500	.125
1060	2.125	.500	.250	2.250	.500	.187	2.375	.625	.125
1070	2.500	.625	.312	2.687	.625	.218	2.875	.750	.125
1080	3.000	.750	.375	3.250	.750	.250	3.375	.875	.187
1090	3.500	.875	.437	3.750	.875	.312	3.875	1.000	.250
1100	4.000	1.000	.500	4.250	1.000	.375	4.500	1.000	.250
1110	4.500	1.000	.500	4.625	1.250	.437	5.000	1.250	.250
1120	5.000	1.250	.625	5.375	1.250	.437	5.750	1.500	.250
1130	6.000	1.500	.750	6.500	1.500	.500	6.500	1.500	.250
1140	7.000	1.750	.875	7.250	1.750	.750	7.750	2.000	.500

Type T31 & T35 Shaft Hub Bore (Spacer Type) Capacity with Square and Rectangular Keys ① ②

Size	For One Square Key			For One Rectangular Key					
	Max. Bore (in.)	Y = X		Max. Bore (in.)	Y = X		Y = W/2		
		W	X		W	X	W	X	
1020	1.375	.312	.156	1.437	.375	.125	1.562	.375	.062
1030	1.625	.375	.188	1.750	.375	.125	-	-	-
1040	2.125	.500	.250	2.250	.500	.188	2.375	.625	.125
1050	2.375	.625	.312	2.500	.625	.218	2.625	.625	.125
1060	2.875	.750	.375	3.125	.750	.250	3.250	.750	.125
1070	3.125	.750	.375	3.250	.750	.250	3.375	.875	.188
1080	3.500	.875	.438	3.750	.875	.312	3.875	1.000	.250
1090	4.000	1.000	.500	4.250	1.000	.375	4.500	1.000	.250
1100	4.750	1.250	.625	5.000	1.250	.438	5.250	1.250	.250
1110	5.500	1.250	.625	5.875	1.500	.500	6.250	1.500	.250
1120	6.250	1.500	.750	6.500	1.500	.500	6.750	1.750	.625
1130	6.750	1.750	.875	7.000	1.750	.750	7.250	1.750	.625
1140	7.500	2.000	1.000	8.000	2.000	.750	8.500	2.000	.500

- ① Size 1020 thru 1090 are furnished with Clearance Fit and one setscrew over the keyway, unless otherwise specified.
- ② Size 1100 thru 1140 are furnished with Interference Fit and no setscrews, unless otherwise specified.
- ③ Standard keyway and bore tolerances (Reference: AGMA Standard 9002-A86)

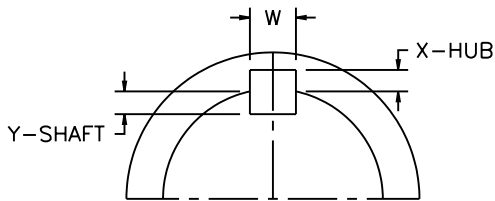

Note: Dimension "Y" (Shaft Keyway Depth) equals one-half of square key. Check key stresses.

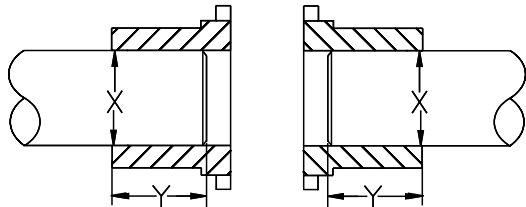

Shaft Engagement

When the distance between the shaft ends is greater than the coupling gap, each shaft must engage the hub by an amount at least equal to the shaft diameter. (Dimension Y must be equal to, or greater than, Dimension x).

Misalignment Capacity

Size	Recommended Installation Maximum		Maximum Operating		Normal Gap ± 10%	
	Offset (Parallel)	Angular X-Y	Offset (Parallel)	Angular X-Y	T10, T20, T31	T35
1020	0.006	0.003	0.012	0.010	0.125	0.188
1030	0.006	0.003	0.012	0.012	0.125	0.188
1040	0.006	0.003	0.012	0.013	0.125	0.188
1050	0.008	0.004	0.016	0.016	0.125	0.188
1060	0.008	0.005	0.016	0.018	0.125	0.188
1070	0.008	0.005	0.016	0.020	0.125	0.188
1080	0.008	0.006	0.016	0.024	0.125	0.188
1090	0.008	0.007	0.016	0.028	0.125	0.188
1100	0.010	0.008	0.020	0.033	0.188	0.250
1110	0.010	0.009	0.020	0.036	0.188	0.250
1120	0.011	0.010	0.022	0.040	0.250	0.375
1130	0.011	0.012	0.022	0.047	0.250	0.375
1140	0.011	0.013	0.022	0.053	0.250	0.375

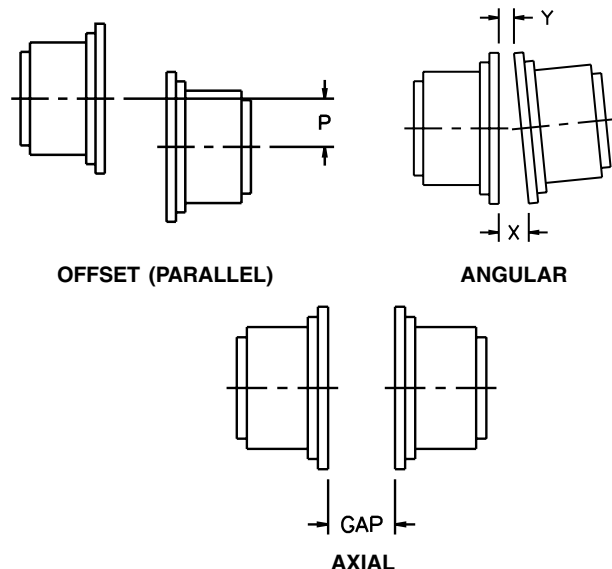

The KOP-GRID® T31 full spacer coupling is designed for medium-duty applications requiring greater shaft separations, such as process pumps that are typical of the Pulp & Paper, Petrochemical and Process industries. This full-flex spacer coupling is available in a wide variety of shaft separations by using combinations of standard, interchangeable spacer hubs. The drop-out center section permits easy pump and equipment maintenance. The shaft hubs, normally furnished for a clearance fit to AGMA Standards, accept large equipment shafts for application versatility.

The KOP-GRID® T31 coupling is specifically engineered to be interchangeable with other tapered grid spacer couplings, by component — hubs (shaft and spacer), grid, seals — and cover assembly.

KOP-GRID® T31 Full Spacer Coupling Specifications

Size	Coupling Rating HP/ 100 RPM	Torque Rating (lb.-in.)	Maximum Speed RPM	Maximum Bore		Cplg. Wt. With No Bore - lb.①	Dimensions (Inches)										Flange Fasteners	
				Shaft Hub	Shaft Hub (Bushed)		"BE"②		N	F	E	U	Gap	No. Per Flange & Grade	Dia			
							Min	Max										
1020	0.68	422	3600	1.375	-	8.5	4.00	1.38	3.50	8.00	2.04	3.38	.03	.08	.188	4 Gr 8	.250	
1030	1.93	1200	3600	1.625	-	12	4.38	1.62	3.50	8.50	2.31	3.69	.03	.08	.188	8 Gr 8	.250	
1040	3.22	2000	3600	2.125	1.00	19	4.62	2.12	3.50	8.50	3.06	4.44	.03	.08	.188	8 Gr 8	.250	
1050	5.63	3500	3600	2.375	1.50	28	5.44	2.36	4.38	8.50	3.44	4.96	.03	.08	.188	8 Gr 8	.312	
1060	8.85	5500	3600	2.875	1.750	43	5.94	2.88	5.00	13.00	4.06	5.71	.06	.11	.188	8 Gr 8	.375	
1070	13	8000	3600	3.125	1.750	54	6.38	3.12	5.00	13.00	4.28	6.02	.06	.11	.188	12 Gr 8	.375	
1080	27	16500	3600	3.500	2.688	87	7.64	3.50	7.25	16.00	4.81	7.00	.06	.11	.188	12 Gr 8	.500	
1090	48	30000	3600	4.000	2.688	133	8.38	4.02	7.25	16.00	5.59	8.69	.06	.11	.188	12 Gr 8	.625	
1100	81	50500	2440	4.750	3.75	218	9.84	3.54	8.00	16.00	6.73	9.88	.06	.12	.250	12 Gr 8	.750	

① Weight is calculated with No Bore and minimum "BE" dimension.

② See page 221 for standard "BE" dimensions and part numbers.

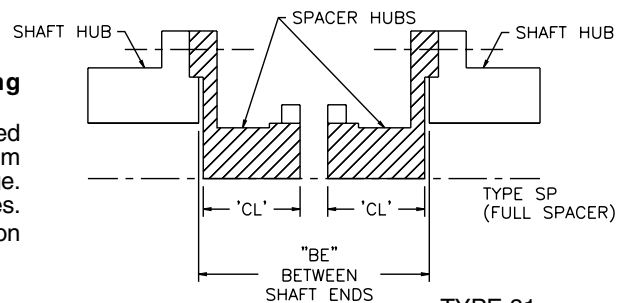
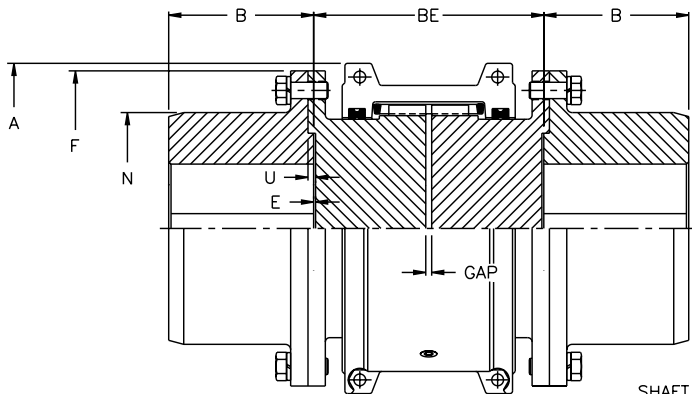

A KOP-GRID® T31 Full Spacer consists of the following components:

Shaft Hubs - Two (2) shaft hubs with either a minimum bore or bored to accept a BROWNING® Brand SPLIT TAPER™ bushing. Minimum bore hubs can be supplied bored-to-size at a nominal additional charge. Bushings are available at an additional cost in a variety of bore sizes.

Spacer Hubs - Two (2) Spacer Grid hubs are required. See Table on Page 221.

T10 Cover and Grid Assembly - One (1) is required.

KOP-GRID® T31 Coupling

Part Numbers (see next page for spacer hubs)

Size	HUBS			T10 Cover and Grid Assembly	Tapered Grid Kit	T10 Cover Kit	T10 Accessory Kit
	Shaft Hub No Bore	Shaft Hub Bushed	Bushing				
1020	1020 SHUB	-	-	1020T10 CGA	1020 GRID	1020T10 COVER	1020T10 AK
1030	1030 SHUB	-	-	1030T10 CGA	1030 GRID	1030T10 COVER	1030T10 AK
1040	1040 SHUB	1040 SHUBXG	G	1040T10 CGA	1040 GRID	1040T10 COVER	1040T10 AK
1050	1050 SHUB	1050 SHUBXH	H	1050T10 CGA	1050 GRID	1050T10 COVER	1050T10 AK
1060	1060 SHUB	1060 SHUBXP	P1	1060T10 CGA	1060 GRID	1060T10 COVER	1060T10 AK
1070	1070 SHUB	1070 SHUBXP	P1	1070T10 CGA	1070 GRID	1070T10 COVER	1070T10 AK
1080	1080 SHUB	1080 SHUBXQ	Q1	1080T10 CGA	1080 GRID	1080T10 COVER	1080T10 AK
1090	1090 SHUB	1090 SHUBXQ	Q1	1090T10 CGA	1090 GRID	1090T10 COVER	1090T10 AK
1100	1100 SHUB	1100 SHUBXR	R1	1100T10 CGA	1100 GRID	1100T10 COVER	1100T10 AK

Specifications and selection data are subject to change without notice. Bushings not included.

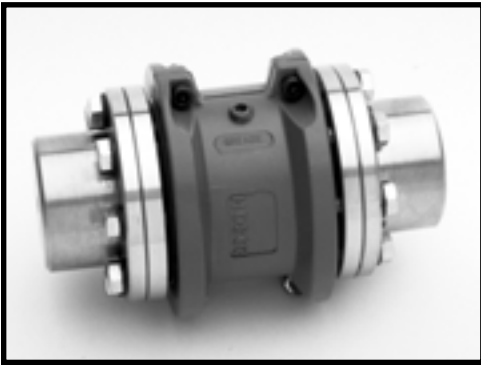

Spacer Hub Length ("CL") for given shaft separation ("BE") Length and Part Number

"BE" LENGTH INCHES	Size 1020			Size 1030			Size 1040			Size 1050			Size 1060		
	CL	Part #	Qty	CL	Part #	Qty	CL	Part #	Qty	CL	Part #	Qty	CL	Part #	Qty
3.500	1.625	1020 SPH178	(2)	1.625	1030 SPH178	(2)	1.625	1040 SPH178	(2)						
3.938	1.625	1020 SPH178	(1)	1.625	1030 SPH178	(1)	1.625	1040 SPH178	(1)						
	2.062	1020 SPH222	(1)	2.062	1030 SPH222	(1)	2.062	1040 SPH222	(1)						
4.250	1.625	1020 SPH178	(1)	1.625	1030 SPH178	(1)	1.625	1040 SPH178	(1)						
	2.375	1020 SPH253	(1)	2.375	1030 SPH253	(1)	2.375	1040 SPH253	(1)						
4.375	2.062	1020 SPH222	(2)	2.062	1030 SPH222	(2)	2.062	1040 SPH222	(2)	2.062	1050 SPH222	(2)			
4.688	2.062	1020 SPH222	(1)	2.062	1030 SPH222	(1)	2.062	1040 SPH222	(1)	2.062	1050 SPH222	(1)			
	2.375	1020 SPH253	(1)	2.375	1030 SPH253	(1)	2.375	1040 SPH253	(1)	2.375	1050 SPH253	(1)			
5.00	2.375	1020 SPH253	(2)	2.375	1030 SPH253	(2)	2.375	1040 SPH253	(2)	2.375	1050 SPH253	(2)	2.344	1060 SPH253	(2)
5.219							1.625	1040 SPH178	(1)						
5.375				1.625	1030 SPH178	(1)	1.625	1040 SPH178	(1)						
				3.500	1030 SPH366	(1)	3.500	1040 SPH366	(1)						
5.656							2.062	1040 SPH222	(1)	2.062	1050 SPH222	(1)			
							3.344	1040 SPH350	(1)	3.344	1050 SPH350	(1)			
5.813				2.062	1030 SPH222	(1)	2.062	1040 SPH222	(1)	2.062	1050 SPH222	(1)			
				3.500	1030 SPH366	(1)	3.500	1040 SPH366	(1)	3.500	1050 SPH366	(1)			
5.969							2.375	1040 SPH253	(1)	2.375	1050 SPH253	(1)			
							3.344	1040 SPH350	(1)	3.344	1050 SPH350	(1)			
6.125				2.375	1030 SPH253	(1)	2.375	1040 SPH253	(1)	2.375	1050 SPH253	(1)	2.344	1060 SPH253	(1)
				3.500	1030 SPH366	(1)	3.500	1040 SPH366	(1)	3.500	1050 SPH366	(1)	3.469	1060 SPH366	(1)
6.938							3.344	1040 SPH350	(2)	3.344	1050 SPH350	(2)			
7.094							3.344	1040 SPH350	(1)	3.344	1050 SPH350	(1)			
							3.500	1040 SPH366	(1)	3.500	1050 SPH366	(1)			
7.250				3.500	1030 SPH366	(2)	3.500	1040 SPH366	(2)	3.500	1050 SPH366	(2)	3.469	1060 SPH366	(2)
8.625													2.344	1060 SPH253	(1)
													5.969	1060 SPH616	(1)
9.750													3.469	1060 SPH366	(1)
													5.969	1060 SPH616	(1)
12.250													5.969	1060 SPH616	(2)

"BE" LENGTH INCHES	Size 1070			Size 1080			Size 1090			Size 1100		
	CL	Part #	Qty	CL	Part #	Qty	CL	Part #	Qty	CL	Part #	Qty
5.00	2.344	1070 SPH253	(2)									
6.125	2.344	1070 SPH253	(1)									
	3.469	1070 SPH366	(1)									
7.250	3.469	1070 SPH366	(2)	3.469	1080 SPH366	(2)	3.469	1090 SPH366	(2)			
8.000										3.812	1100 SPH406	(2)
8.593				3.469	1080 SPH366	(1)						
				4.812	1080 SPH500	(1)						
8.625	2.344	1070 SPH253	(1)									
	5.969	1070 SPH616	(1)									
8.875										3.812	1100 SPH406	(1)
										4.688	1100 SPH494	(1)
9.750	3.469	1070 SPH366	(1)	3.469	1080 SPH366	(1)	3.469	1090 SPH366	(1)	4.688	1100 SPH494	(2)
	5.969	1070 SPH616	(1)	5.969	1080 SPH616	(1)	5.969	1090 SPH616	(1)			
9.938				4.812	1080 SPH500	(2)						
11.093				4.812	1080 SPH500	(1)						
				5.969	1080 SPH616	(1)						
12.250	5.969	1070 SPH616	(2)	5.969	1080 SPH616	(2)						

Similar to the T31, the T35 coupling is engineered for those applications that have shaft separations greater than a close coupled coupling, but less separation than is required in a full spacer coupling.

Versatile, the T35 uses the same horizontally split aluminum alloy cover as the other KOP-GRID® types, and has the same interchangeability of components to other tapered grid couplings.

KOP-GRID® T35 Half Spacer Coupling Specifications

Size	Coupling Rating HP/100 RPM	Torque Rating (lb.-in)	Maximum Speed RPM	Maximum Bore (Square Key)			Cplg. Wt. With No Bore - lb.①	Dimensions - Inches													Flange Fasteners	
				Shaft Hub	Shaft Hub (Bushed)	Grid Hub		A	B	"BE"②		C	D	N	F	E	U	Gap	No. Per Flange & Grade	Dia		
										Min	Max											
1020	0.68	422	3600	1.375	-	1.125	6.4	4.00	1.38	1.78	4.03	1.88	1.56	2.04	3.38	.03	.08	.125	4 Gr 8	.250		
1030	1.93	1200	3600	1.625	-	1.375	8.4	4.38	1.62	1.78	4.28	1.88	1.94	2.31	3.69	.03	.08	.125	8 Gr 8	.250		
1040	3.22	2000	3600	2.125	1.00	1.625	13	4.62	2.12	1.78	4.28	2.00	2.25	3.06	4.44	.03	.08	.125	8 Gr 8	.250		
1050	5.63	3500	3600	2.375	1.50	1.875	20	5.44	2.36	2.22	4.28	2.38	2.62	3.44	4.96	.03	.08	.125	8 Gr 8	.312		
1060	8.85	5500	3600	2.875	1.75	2.125	30	5.94	2.88	2.53	6.53	2.50	3.00	4.06	5.71	.06	.11	.125	8 Gr 8	.375		
1070	13	8000	3600	3.125	1.75	2.500	39	6.38	3.12	2.53	6.53	3.00	3.44	4.28	6.02	.06	.11	.125	12 Gr 8	.375		
1080	27	16500	3600	3.500	2.688	3.000	63	7.64	3.50	3.66	8.03	3.50	4.12	4.81	7.00	.06	.11	.125	12 Gr 8	.500		
1090	48	30000	3600	4.000	2.688	3.500	95	8.38	4.02	3.66	8.03	3.88	4.88	5.59	8.69	.06	.11	.125	12 Gr 8	.625		
1100	81	50500	2440	4.750	3.75	4.000	156	9.84	3.54	4.06	8.06	4.75	5.59	6.73	9.88	.06	.12	.188	12 Gr 8	.750		

① Weight is calculated with No Bore and minimum "BE" dimension.

② See page 223 for standard "BE" dimensions and part numbers.

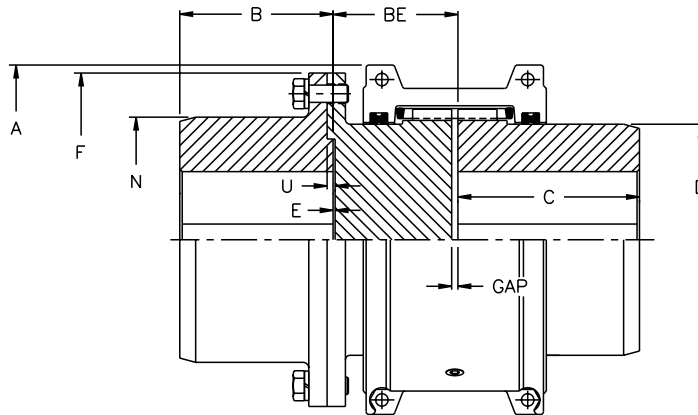

A KOP-GRID® T35 Half Spacer consists of the following components:

Shaft Hubs - One (1) shaft hub with either a minimum bore or bored to size to accept a BROWNING® Brand SPLIT TAPER™ bushing. Bushings are available at an additional cost in a variety of bore sizes.

Spacer Hubs - One (1) Spacer Grid hub is required. See Table on Page 221.

Grid Hub - One (1) Standard Grid Hub is required. Available in either a minimum, finished or bore to accept. See Table on Page 218 for a list of standard finished bores and dimensions.

T10 Cover and Grid Assembly - One (1) is required.

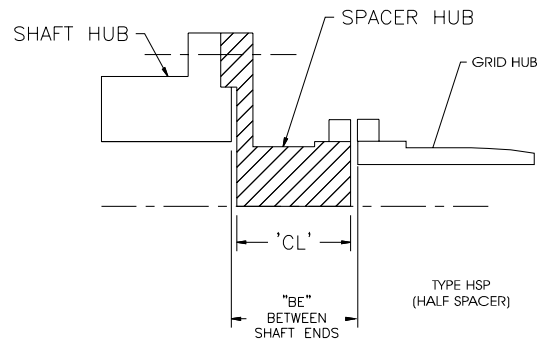

TYPE 35
(HALF SPACER)



KOP-GRID® Half Spacer Couplings

"BE" LENGTH INCHES	Size 1020			Size 1030			Size 1040		
	CL	Part #	Qty	CL	Part #	Qty	CL	Part #	Qty
1.781	1.625	1020 SPH178	(1)	1.625	1030 SHP178	(1)	1.625	1040 SPH178	(1)
2.219	2.062	1020 SPH222	(1)	2.062	1030 SHP222	(1)	2.062	1040 SPH222	(1)
2.531	2.375	1020 SPH253	(1)	2.375	1030 SHP253	(1)	2.375	1040 SPH253	(1)
3.500							3.344	1040 SPH350	(1)
3.656				3.500	1030 SHP366	(1)	3.500	1040 SPH366	(1)

"BE" LENGTH INCHES	Size 1050			Size 1060			Size 1070		
	CL	Part #	Qty	CL	Part #	Qty	CL	Part #	Qty
2.219	2.062	1050 SPH222	(1)						
2.531	2.375	1050 SPH253	(1)	2.344	1060 SPH253	(1)	2.344	1070 SPH253	(1)
3.500	3.344	1050 SPH350	(1)						
3.656	3.500	1050 SPH366	(1)	3.469	1060 SPH366	(1)	3.469	1070 SPH366	(1)
6.156				5.969	1060 SPH616	(1)	5.969	1070 SPH616	(1)

"BE" LENGTH INCHES	Size 1080			Size 1090			Size 1100		
	CL	Part #	Qty	CL	Part #	Qty	CL	Part #	Qty
2.531									
3.656	3.469	1080 SPH366	(1)	3.469	1090 SPH366	(1)			
4.062							3.812	1100 SPH406	(1)
4.938							4.688	1100 SPH494	(1)
5.000	4.812	1080 SPH500	(1)						
6.156	5.969	1080 SPH616	(1)	5.969	1090 SPH616	(1)			

KOP-GRID® T35 Coupling Part Numbers

Size	Grid Hub	Grid Hub Bushed	Bushing	Shaft Hub Bushed	Bushing	T10 Cover and Grid Assembly	Tapered Grid Kit	T10 Cover Kit	T10 Accessory Kit
1020	1020 HUB	-	-	-	-	1020T10 CGA	1020 GRID	1020T10 COVER	1020T10 AK
1030	1030 HUB	-	-	-	-	1030T10 CGA	1030 GRID	1030T10 COVER	1030T10 AK
1040	1040 HUB	1040 HUBXG	G	1040 SHUBXG	G	1040T10 CGA	1040 GRID	1040T10 COVER	1040T10 AK
1050	1050 HUB	1050 HUBXH	H	1050 SHUBXH	H	1050T10 CGA	1050 GRID	1050T10 COVER	1050T10 AK
1060	1060 HUB	1060 HUBXP	P	1060 SHUBXP	P1	1060T10 CGA	1060 GRID	1060T10 COVER	1060T10 AK
1070	1070 HUB	1070 HUBXP	P	1070 SHUBXP	P1	1070T10 CGA	1070 GRID	1070T10 COVER	1070T10 AK
1080	1080 HUB	1080 HUBXQ	Q	1080 SHUBXQ	Q	1080T10 CGA	1080 GRID	1080T10 COVER	1080T10 AK
1090	1090 HUB	1090 HUBXQ	Q	1090 SHUBXQ	Q1	1090T10 CGA	1090 GRID	1090T10 COVER	1090T10 AK
1100	1100 HUB	1100 HUBXR	R	1100 SHUBXR	R1	1100T10 CGA	1100 GRID	1100T10 COVER	1100T10 AK



Visit www.kopflex.com