



Agricultural Bearings

www.kml-bearing.com

Tough



Bringing Motion
To Your World



CONTENTS

Disc Harrow Ball Bearings

Non-Relubricatable type

Cylindrical O.D. 01

Spherical O.D. 02

Relubricatable type

Round bore 04

Square bore 05

Disc Harrow Units

Relubricatable type

Inch Size 06

Metric Size 06

Hex Bore Series

Non-Relubricatable type 07

Relubricatable type 08

Light 200 Series

R-Seal type 09

CS 200 DDU Series

Ball Bearings 09

Special Size

Ball Bearings 10

Pressed Steel Housing 15

Interchange 18



Triple-lip seal

Features:

Better dust proofing and waterproofing ensure a longer bearing life.

Tri-Ply Seal ball bearings are designed for environments where severe contamination is present, especially in agricultural equipment. Tri-Ply seals are a one-piece design that incorporates three seals molded to a shroud cap. This combination provides excellent protection against contaminants and prevents the loss of lubricating grease. This special seal ensures a longer service life.

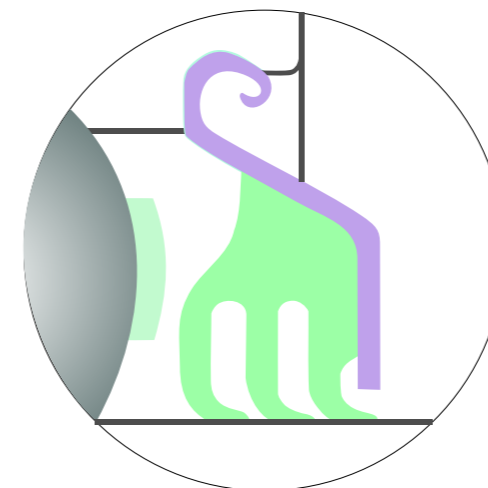

Sealing device

The rubber seal extends to the outer circumference the shielded plate for better sealing performance, and prevents contamination of the bearing by dust or foul water.

Sealed plate

Galvanized steel plate construction ensures improved corrosion resistance. Optimal design contributes to enhanced pressure resistance.

Triple-lip

Provides excellent dustproofing and waterproofing, this protecting against contamination by dust or foul water.

Disc Harrow Ball Bearings
Tri-Ply Seal Series
 Non-Relubricatable type
 Cylindrical O.D.

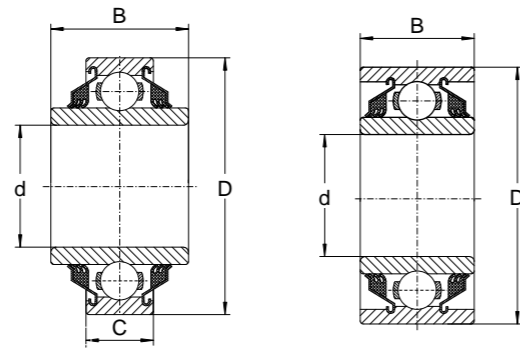

Type 1

Type 2

Round bore

KML No.	Type	Bore d		Outside Diameter D		Ring Width B C		Static load rating Cor	Dynamic load rating Cor	Mass lbs/kg
		In/mm	Tolerance +0.000" +0.000mm to minus	In/mm	Tolerance +0.000" +0.000mm to minus	In/mm	In/mm			
			In/mm		In/mm					
W208PP10	1	1.5005	0.0005	3.1496	0.0005	1.688	0.827	4500	8300	1.50
		38.113	0.013	80	0.013	42.96	21.00	19900	36800	0.680
W210PP8	2	1.5300	0.0100	3.5433	0.0006	1.188	1.188	5200	9000	1.97
		38.860	0.250	90	0.015	30.18	30.18	23000	39900	0.894
W210PP2	2	1.9380	0.0005	3.5433	0.0006	1.188	1.188	5200	9000	1.69
		49.230	0.013	90	0.015	30.18	30.18	23000	39900	0.767
W211PP2	2	2.1880	0.0006	3.9370	0.0006	1.312	1.312	6550	11000	2.33
		55.580	0.015	100	0.015	33.34	33.34	29000	48800	1.056
W214PP2	2	2.7559	0.0006	4.9213	0.0008	1.562	1.562	9800	16000	4.19
		70.000	0.015	125	0.020	39.69	39.69	43500	71000	1.901
W315PP2	2	3.0056	0.0006	6.2992	0.0010	2.688	2.688	16000	28500	13.13
		76.342	0.015	160	0.025	68.26	68.26	71000	125000	5.956

Square bore

KML No.	Type	Shaft size	Outside Diameter D		Ring Width B C		Static load rating Cor	Dynamic load rating Cor	Mass lbs/kg
			In/mm	Tolerance +0.000" +0.000mm to minus	In/mm	In/mm			
				In/mm					
W208PP6	1	1	3.1496	0.0005	1.438	0.709	4500	8300	1.62
		25.4	80	0.013	36.51	18	19900	36800	0.73
W208PP5	1	1 1/8	3.1496	0.0005	1.438	0.709	4500	8300	1.5
		28.6	80	0.013	36.51	18	19900	36800	0.68
W208PP20	1	1 1/8	3.1496	0.0005	1.438	0.709	4500	8300	1.5
		28.6	80	0.013	36.51	18	19900	36800	0.68
W208PP8	1	1 1/8	3.1496	0.0005	1.438	1.188	4500	8300	1.66
		28.6	80	0.013	36.51	30.18	19900	36800	0.75
W211PP3	2	1 1/2	3.9370	0.0006	1.312	1.312	6550	11000	2.79
		38.1	100	0.015	33.34	33.34	29000	48800	1.27
W211PP5	1	1 1/2	4.0000	0.0006	1.75	1.438	6550	11000	3.48
		38.1	101.6	0.015	44.45	36.52	29000	48800	1.58

Disc Harrow Ball Bearings
Tri-Ply Seal Series
 Non-Relubricatable type
 Spherical O.D.

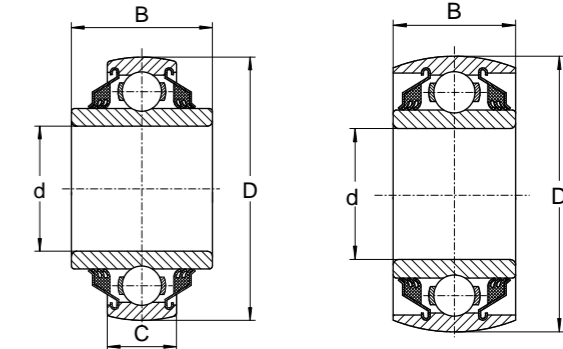

Type 1

Type 2

Round bore

KML No.	Type	Bore d		Outside Diameter D		Ring Width B C		Static load rating Cor	Dynamic load rating Cor	Mass lbs/kg
		In/mm	Tolerance +0.000" +0.000mm to minus	In/mm	Tolerance +0.000" +0.000mm to minus	In/mm	In/mm			
			In/mm		In/mm					
W208PPB7	1	1.188	0.0005	3.150	0.0005	1.188	0.709	4500	8300	1.41
		30.17	0.013	80	0.013	30.18	18	19900	36800	0.640
W208PPB2	1	1.5005	0.0005	3.150	0.0005	1.688	0.709	4500	8300	1.59
		38.113	0.013	80	0.013	42.96	18	19900	36800	0.721
W208PPB23	1	1.5005	0.0005	3.150	0.0005	1.688	1.188	3550	7200	1.5
		38.113	0.013	80	0.013	42.96	30.18	15600	32000	0.68
W209PPB2	2	1.7717	0.0005	3.346	0.0006	1.188	1.188	4550	8300	1.44
		45	0.013	85	0.015	30.18	30.18	20200	36800	0.653
W209PPB4	2	1.5350	0.0100	3.346	0.0006	1.188	1.188	4550	8300	1.65
		39	0.250	85	0.015	30.18	30.18	20200	36800	0.748
W210PPB2	2	1.9380	0.0005	3.543	0.0006	1.188	1.188	5200	9000	1.56
		49.225	0.013	90	0.015	30.18	30.18	23000	39900	0.708
W210PPB5	2	1.7850	0.0100	3.543	0.0006	1.188	1.188	5200	9000	1.75
		45.34	0.250	90	0.015	30.18	30.18	23000	39900	0.794
W211PPB2	2	2.1880	0.0006	3.937	0.0006	1.312	1.312	6550	11000	3.63
		55.58	0.015	100	0.015	33.34	33.34	29000	48800	0.966
W214PPB2	2	2.7559	0.0006	4.921	0.0008	1.562	1.562	9800	16000	3.96
		70	0.015	125	0.020	39.69	39.69	43500	71000	1.796
W214PPB9	1	2.7660	0.0010	4.921	0.0008	1.750	1.102	9800	16000	3.96
		70.26	0.025	125	0.020	44.45	28	43500	71000	1.796

Disc Harrow Ball Bearings
Tri-Ply Seal Series
 Non-Relubricatable type
 Spherical O.D.

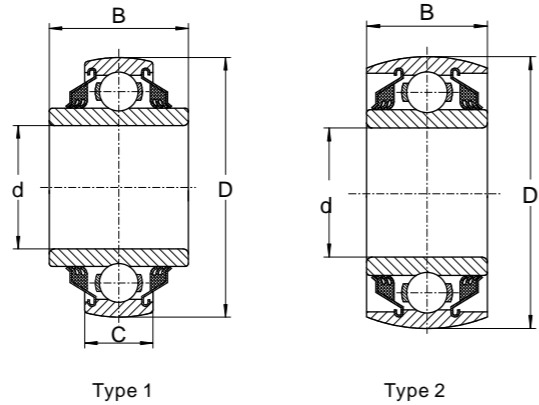

Disc Harrow Ball Bearings
Tri-Ply Seal Series
 Relubricatable type
 Round bore

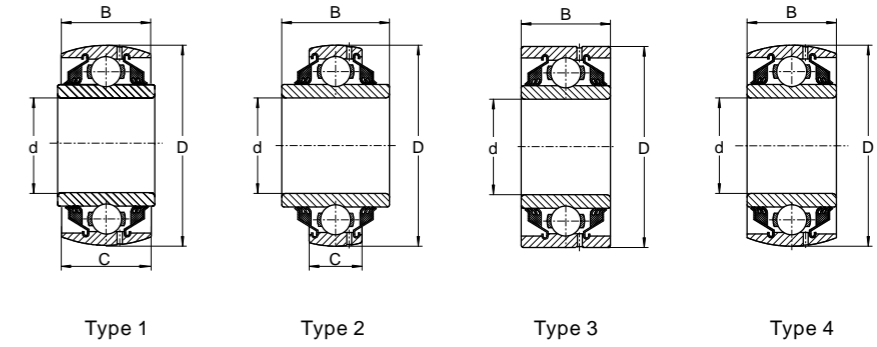

Square bore

KML No.	Type	Shaft size	Outside Diameter D		Ring Width B C		Static load rating Cor	Dynamic load rating Cor	Mass lbs/kg
			In/mm	Tolerance +0.000* +0.000mm to minus	+0.000*, -0.005* +0.00, -.12mm				
					In/mm	In/mm			
W208PPB13	1	7/8 22.2	3.1496 80	0.0005 0.013	1.438 36.53	0.709 18.00	4500 19900	8300 36800	1.62 0.735
W208PPB6	1	1 25.4	3.1496 80	0.0005 0.013	1.438 36.53	0.709 18.00	4500 19900	8300 36800	1.59 0.721
W208PPB5	1	1 1/8 28.6	3.1496 80	0.0005 0.013	1.438 36.53	0.709 18.00	4500 19900	8300 36800	1.47 0.667
W209PPB5	1	1 1/4 31.8	3.3465 85	0.0006 0.015	1.438 36.53	1.188 30.18	4550 20200	8300 36800	1.75 0.794
W210PPB4	2	1 1/8 28.6	3.5433 90	0.0006 0.015	1.188 30.18	1.188 30.18	5200 23000	9000 39900	2.11 0.957
W210PPB6	1	1 1/8 28.6	3.5433 90	0.0006 0.015	1.438 36.53	1.188 30.18	5200 23000	9000 39900	2.25 1.021
W211PPB3	2	1 1/2 38.1	3.9370 100	0.0006 0.015	1.312 33.34	1.312 33.34	6550 29000	11000 48800	2.66 1.207
W208PPB8	1	1 1/8 28.6	3.1496 80	0.0005 0.013	1.437 36.53	1.189 30.18	4500 19900	8300 36800	0.75 1.652
W208PPB9	1	1 25.4	3.1496 80	0.0005 0.013	1.437 36.53	1.189 30.18	4500 19900	8300 36800	0.79 1.740
W208PPB11	1	7/8 22.23	3.3760 85.750	0.0006 0.015	1.437 36.53	1.189 30.18	4500 19900	8300 36800	0.93 2.048
W208PPB12	1	1 1/8 28.6	3.3760 85.750	0.0006 0.015	1.437 36.53	1.189 30.18	4500 19900	8300 36800	0.85 1.872
W208PPB13	1	7/8 22.23	3.1496 80.000	0.0006 0.015	1.437 36.53	0.709 18.00	4500 19900	6300 36800	0.93 2.048
W209PPB7	1	1 1/4 31.8	3.3760 85.750	0.0006 0.015	1.437 36.53	1.189 30.18	4500 19900	8300 36800	0.84 1.850
W211PPB6	1	1 1/2 38.1	4.077 103.556	0.0006 0.015	1.750 44.450	1.438 36.520	4500 19900	8300 36800	0.75 1.652

KML No.	Type	Bore d		Outside Diameter D		Ring Width B C		Static load rating Cor	Dynamic load rating Cor	Mass lbs/kg
		In/mm	tolerance +0.000* +0.000mm to minus	In/mm	tolerance +0.000* +0.000mm to minus	+0.000*, -0.005* +0.00, -.12mm				
						In/mm	In/mm			
GW209PPB2	4	1.7717 45.00	0.005 0.013	3.3465 85.00	0.0006 0.015	1.188 30.18	1.188 30.18	4550 20200	8300 36800	1.44 0.653
GW209PPB11	2	1.7810 45.24	0.0100 0.250	3.3465 85	0.0006 0.015	1.438 36.530	0.866 22.00	4550 20200	8300 36800	1.37 0.614
GW209PPB4	4	1.5350 39.00	0.0100 0.250	3.3465 85	0.0006 0.015	1.188 30.18	1.188 30.18	4550 20200	8300 36800	1.65 0.681
GW210PP3	3	1.4065 37.53	0.0005 0.013	3.5433 90	0.0006 0.015	1.188 30.18	1.188 30.18	5200 23000	9000 39900	2.25 1.021
GW210PP9	2	1.9450 49.40	0.0007 0.180	3.5433 90	0.0006 0.015	1.438 36.53	0.906 23.00	5200 23000	9000 39900	1.75 0.794
GW210PPB2	4	1.9380 49.23	0.0005 0.013	3.5433 90	0.0006 0.015	1.188 30.18	1.188 30.18	5200 23000	9000 39900	1.5 0.680
GW210PPB5	4	1.7850 45.34	0.0100 0.250	3.5433 90	0.0006 0.015	1.188 30.18	1.188 30.18	5200 23000	9000 39900	1.75 0.794
GW211PP2	3	2.1880 55.58	0.0006 0.015	3.9370 100	0.0006 0.015	1.312 33.34	1.312 33.34	6550 29000	11000 48800	3 1.361
GW211PPB10	4	1.9380 49.23	0.0006 0.015	3.9370 100	0.0006 0.015	1.312 33.34	1.312 33.34	6550 29000	11000 48800	2.26 1.025
GW211PPB13	2	1.7850 45.34	0.0100 0.250	3.9370 100	0.0006 0.015	1.312 33.34	0.984 25.00	6550 29000	11000 48800	2.02 0.916
GW211PPB14	2	2.0150 51.18	0.0100 0.250	3.9370 100	0.0006 0.015	1.312 33.34	0.984 25.00	6550 29000	11000 48800	2 0.907
GW211PPB2	4	2.1880 55.58	0.0006 0.015	3.9370 100	0.0006 0.015	1.312 33.34	1.312 33.34	6550 29000	11000 48800	2.62 1.188
GW211PPB8	2	2.1880 55.58	0.0006 0.015	3.9370 100	0.0006 0.015	1.312 33.34	0.984 25	6550 29000	11000 48800	1.85 0.839
GW211PPB9	2	2.1950 55.75	0.0070 0.180	3.9370 100	0.0006 0.015	1.562 39.69	0.984 25.00	6550 29000	11000 48800	2.02 0.916
GW214PPB6	2	2.6881 68.28	0.0006 0.015	4.9213 125	0.0008 0.020	2.688 68.26	1.102 28.00	9800 43500	16000 71000	4.75 2.155
GW214PP2	3	2.7559 70.00	0.0006 0.015	4.9213 125	0.0008 0.020	1.562 39.69	1.562 39.69	9800 43500	16000 71000	4.19 1.901
GW214PPB2	4	2.7559 70.00	0.0006 0.015	4.9213 125	0.0008 0.020	1.562 39.69	1.562 39.69	9800 43500	16000 71000	3.96 1.796
GW214PPB5	1	2.7559 70.00	0.0006 0.015	4.9213 125	0.0008 0.020	2.438 61.90	1.562 39.69	9800 43500	16000 71000	4.75 2.155
GW216PPB3	2	3.0100 76.45	0.0100 0.250	5.5118 140	0.0008 0.020	2.500 63.50	1.181 30.00	10200 45000	18000 80000	
GW216PP5	3	2.5150 63.83	0.0100 0.250	5.5118 140	0.0008 0.020	2.500 63.50	1.181 30.00	10200 45000	18000 80000	

Disc Harrow Ball Bearings
Tri-Ply Seal Series
 Relubricatable type
 Square bore

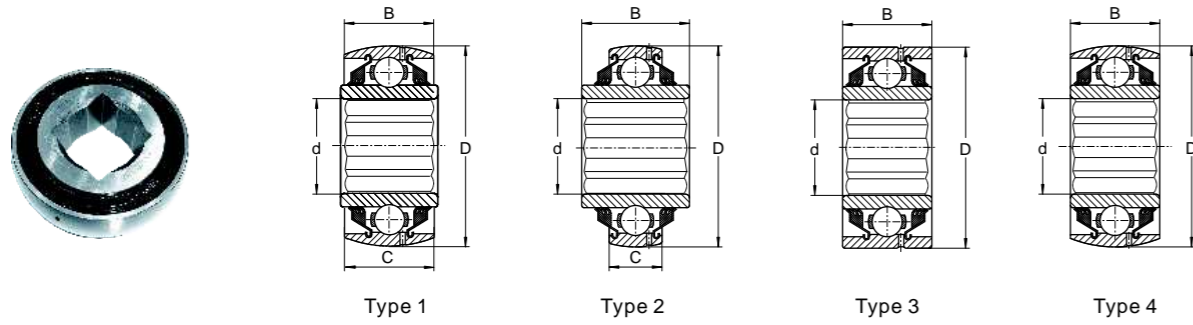

Disc Harrow Units
Tri-Ply Series
 Relubricatable type

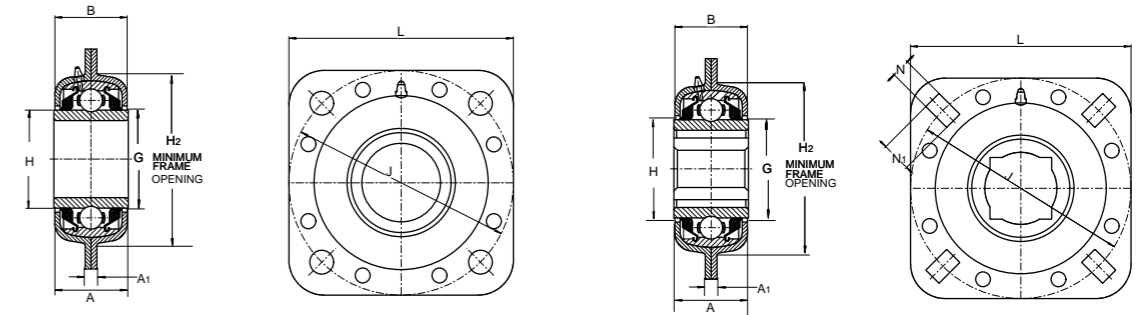

Inch Size

Unit No.	Shaft Diam.	Boundary dimensions (inch)										Static Load Rating Cor	Extended Dynamic Load Rating Cr
		B	H ₂	J	N ₁	N	L	G Ref.	H	A	A ₁		
ST491B	1 1/2 RD.	1 11/16	4	5	2 1/32	1 7/32	5	2.279	2 23/64	1 43/64	1 7/64	4000	8150
DHU 1 1/8S-209	1 1/8 SQ.	1 11/16	4	5	2 1/32	1 7/32	5	2.279	2 23/64	1 43/64	1 7/64	4000	8150
DHU 1 3/4R-209	1 3/4 RD.	1 11/16	4	5	2 1/32	1 7/32	5	2.279	2 23/64	1 43/64	1 7/64	4000	8150
DHU 1 1/4S-209	1 1/4 SQ.	1 3/4	4	5	2 1/32	1 7/32	5	2.279	2 23/64	1 43/64	1 7/64	4000	8150
ST491A	1 3/4 RD.	1 3/4	4	5	2 1/32	1 7/32	5	2.279	2 23/64	1 43/64	1 7/64	4000	8150
DHU 1 1/2S-211	1 1/2 SQ.	2	4	5 1/2	1 9/32	1 7/32	5 1/2	2.746	2 7/8	1 15/16	1 9/64	5600	10800
DHU 1 3/4R-211	1 3/4 RD.	2 1/8	4	5 1/2	1 9/32	1 7/32	5 1/2	2.746	2 7/8	1 15/16	1 9/64	5600	10800
DHU 2 3/16R-211	2 3/16 RD.	2 3/16	4	5 1/2	1 9/32	1 7/32	5 1/2	2.746	2 7/8	1 15/16	1 9/64	5600	10800

Metric Size

Unit No.	Shaft Diam.	Boundary dimensions (mm)										Static Load Rating Cor	Extended Dynamic Load Rating Cr
		B	H ₂	J	N ₁	N	L	G Ref.	H	A	A ₁		
DHU 30S-209	30 SQ.	43	101.6	127	16.7	13.5	127	57.9	59.9	42.5	6.7	18000	36500
DHU 40R-209	40 SQ.	43	101.6	127	16.7	13.5	127	57.9	59.9	42.5	6.7	18000	36500
DHU 45R-209	50 RD.	43	101.6	127	16.7	13.5	127	57.9	59.9	42.5	6.7	18000	36500
DHU 40S-211	40 SQ.	51	113.5	139.7	15.1	13.5	139.7	69.7	73	49.2	7.5	25000	48000
DHU 50R-211	50 RD.	51	113.5	139.7	15.1	13.5	139.7	69.7	73	49.2	7.5	25000	48000
DHU 55R-211	55 RD.	51	113.5	139.7	15.1	13.5	139.7	69.7	73	49.2	7.5	25000	48000

KML No.	Type	Shaft size	Outside Diameter D		Ring Width B C		Static load rating Cor	Dynamic load rating Cor	Mass lbs/kg
			Tolerance +0.000* +0.000mm to minus	+0.000*,-0.005* +0.00,-.12mm	lbf/N	lbf/N			
			In/mm	In/mm					
GW208PPB6	2	1	3.1496	0.0005	1.438	0.827	4500	8300	1.75
		25.4	80	0.013	36.53	21.00	19900	36800	0.794
GW208PPB5	2	1 1/8	3.1496	0.0005	1.438	0.827	4500	8300	1.47
		28.6	80.000	0.013	36.53	21.00	19900	36800	0.667
GW208PPB8	1	1 1/8	3.1496	0.0005	1.438	1.188	4500	8300	1.75
		28.6	80	0.013	36.53	30.18	19900	36800	0.794
GW208PPB17	3	1 1/8	3.3755	0.0005	1.438	1.188	4500	8300	2.04
		28.6	85.738	0.013	36.53	30.18	19900	36800	0.925
GW209PPB5	1	1 1/4	3.3456	0.0006	1.438	1.188	4550	8300	1.75
		31.8	85	0.015	36.53	30.18	20200	36800	0.794
GW209PPB8	2	1 1/4	3.346	0.0006	1.438	0.866	4550	8300	1.65
		31.8	85	0.015	36.53	22.00	20200	36800	0.748
GW210PP4	3	1 1/8	3.5433	0.0006	1.188	1.188	5200	9000	2.31
		28.6	90	0.015	30.18	30.18	23000	39900	1.048
GW210PPB4	4	1 1/8	3.5433	0.0006	1.188	1.188	5200	9000	1.75
		28.6	90	0.015	30.18	30.18	23000	39900	0.794
GW211PP3	3	1 1/2	3.937	0.0006	1.312	1.312	6550	11000	2.79
		38.1	100	0.015	33.34	33.34	29000	48800	1.266
GW211PPB3	4	1 1/2	3.937	0.0006	1.312	1.312	6550	11000	2.66
		38.1	100	0.015	33.34	33.34	29000	48800	1.207
GW211PP17	3	1 1/2	3.937	0.0006	1.750	1.312	6550	11000	2.62
		38.1	100	0.015	44.45	33.34	29000	48800	1.188
GW214PPB4	4	2	4.921	0.0008	1.562	1.562	9800	16000	4.75
		50.8	125	0.020	39.68	39.680	43500	71000	2.155
GW216PPB4	2	1 3/4	5.5118	0.0008	2.5	1.181	10200	18000	
		44.4	140	0.020	63.5	30.00	45000	80000	
GW216PP2	2	2 1/4	5.5118	0.0008	2.5	1.181	10200	18000	
		57.2	140	0.020	63.5	30.00	45000	80000	
GW216PPB2	2	2 1/4	5.5118	0.0008	2.5	1.181	10200	18000	
		57.2	140	0.020	63.5	30.00	45000	80000	

Hex Bore Series
Non-Relubricatable Type

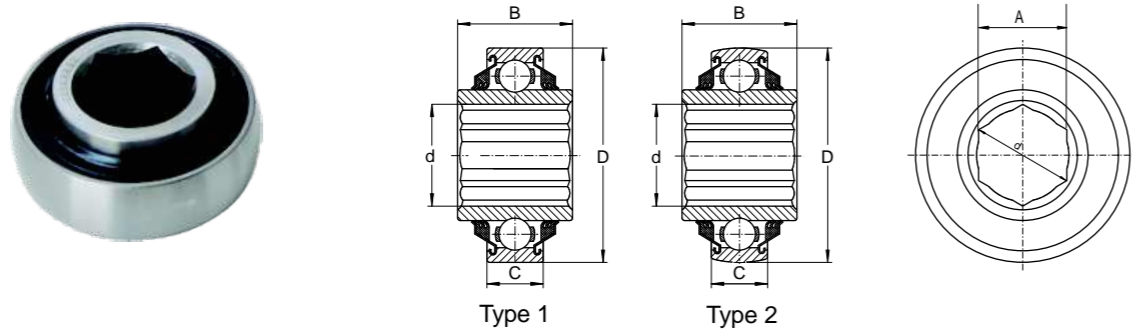

KML No.	Type	Hex Shaft size	Hex Bore			Outside Diameter		Width		Static load rating Cor	Dynamic load rating Cor	Mass lbs/kg
			A	tolerance +0.000* -0.00mm to minus	d	D	tolerance +0.000* -0.000mm to minus	C	B			
			Across flats		Across comers min.		outer	inner				
In/mm	In/mm	In/mm	In/mm	In/mm	In/mm	In/mm	In/mm	lbf/N	lbf/N			
202KRR3	1	9/16	0.563	0.005	0.648	1.3780	0.0005	0.433	0.512	1000	2360	0.12
			14.30	0.13	16.46	35	0.013	11	13	4400	10600	0.054
204KRR2	1	11/16	0.695	0.005	0.796	1.8504	0.0005	0.551	0.825	1400	3200	0.32
			17.65	0.13	20.22	47	0.013	14	20.96	6200	14300	0.145
205KRR2	1	7/8	0.876	0.005	1.010	2.0472	0.0005	0.591	1.000	1560	3450	0.44
			22.25	0.13	25.65	52	0.013	15	25.4	6950	15600	0.2
205KRRB2	2	7/8	0.876	0.005	1.010	2.0472	0.0005	0.591	1.000	1560	3450	0.44
			22.25	0.13	25.65	52	0.013	15	25.4	6950	15600	0.2
205PPB13	2	7/8	0.876	0.005	1.010	2.0472	0.0005	0.591	1.000	1560	3450	0.44
			22.25	0.13	25.65	52	0.013	15	25.4	6950	15600	0.2
206KPP3	1	1	1.001	0.005	1.152	2.4409	0.0005	0.630	0.945	2280	4800	0.76
			25.43	0.13	29.26	62	0.013	16	24	10000	21600	0.345
206KPPB3	2	1	1.001	0.005	1.152	2.4409	0.0005	0.630	0.945	2280	4800	0.76
			25.43	0.13	29.26	62	0.013	16	24	10000	21600	0.345
206KRR6	1	1	1.001	0.005	1.152	2.4409	0.0005	0.630	0.945	2280	4800	0.75
			25.43	0.13	29.26	62	0.013	16	24	10000	21600	0.34
206KRRB6	2	1	1.001	0.005	1.152	2.4409	0.0005	0.630	0.945	2280	4800	0.75
			25.43	0.13	29.26	62	0.013	16	24	10000	21600	0.34
207KPP3	1	1 1/4	1.251	0.005	1.433	2.8346	0.0005	0.669	1.484	3050	6400	1
			31.77	0.13	36.40	72	0.013	17	37.7	13700	28500	0.454
207KPPB3	2	1 1/4	1.251	0.005	1.433	2.8346	0.0005	0.669	0.984	3050	6400	0.87
			31.77	0.13	36.40	72	0.013	17	25	13700	28500	0.395
207KRRB9	2	1 1/8	1.126	0.005	1.298	2.8346	0.0005	0.669	1.484	3050	6400	1
			28.60	0.13	32.97	72	0.013	17	37.7	13700	28500	0.454
207KRRB12	2	1 1/8	1.126	0.005	1.298	2.8346	0.0005	0.669	0.984	3050	6400	0.87
			28.60	0.13	32.97	72	0.013	17	25	13700	28500	0.395
207KRR17	1	1 1/4	1.251	0.005	1.433	2.8346	0.0005	0.669	0.984	3050	6400	0.87
			31.77	0.13	36.40	72	0.013	17	25	13700	28500	0.395
207KRRB17	2	1 1/4	1.251	0.005	1.433	2.8346	0.0005	0.669	0.984	3050	6400	0.87
			31.77	0.13	36.40	72	0.013	17	25	13700	28500	0.395
W208PPB16	2	1 1/4	1.251	0.005	1.443	3.1496	0.0005	0.709	1.438	4000	8150	1.45
			31.77	0.13	36.65	80	0.013	18	36.53	17600	36000	0.658
W208KRRB6	2	1 3/8	1.376	0.005	1.587	3.1496	0.0005	0.827	1.438	4000	8150	
			34.95	0.13	40.30	80	0.013	21	36.53	17600	36000	
W208KRR8	1	1 1/4	1.251	0.005	1.443	3.1496	0.0005	0.709	1.438	4000	8150	1.45
			31.77	0.13	36.65	80	0.013	18	36.53	17600	36000	0.658
209KRRB2	2	1 1/2	1.501	0.005	1.730	3.3456	0.0006	0.748	1.181	4000	8150	1.27
			38.12	0.13	43.94	85	0.015	19	30	17600	36000	0.576
W210PPB7	2	1 5/8	1.626	0.005	1.876	3.5433	0.0006	1.188	1.188	4500	8800	1.75
			41.30	0.13	47.65	90	0.015	30.18	30.18	19600	39000	0.794

Hex Bore Series
Relubricatable Type

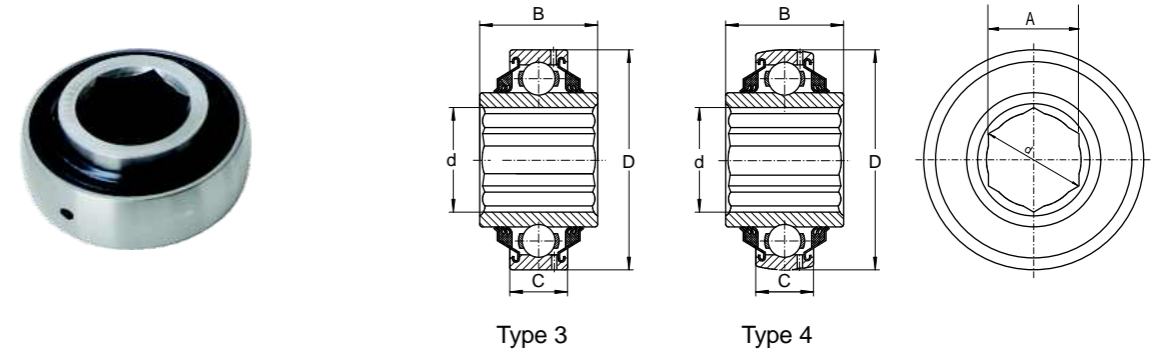

KML No.	Type	Hex Shaft size	Hex Bore			Outside Diameter		Width		Static load rating Cor	Dynamic load rating Cor	Mass lbs/kg
			A	tolerance +0.000* -0.00mm to minus	d	D	tolerance +0.000* -0.000mm to minus	C	B			
			Across flats		Across comers min.		outer	inner				
In/mm	In/mm	In/mm	In/mm	In/mm	In/mm	In/mm	lbf/N	lbf/N				
G206KPP4	3	1	1.001	0.005	1.152	2.4409	0.005	0.709	0.945	2280	4800	0.62
			25.43	0.13	29.26	62	0.13	18	24	10000	21600	0.281
G206KPPB4	4	1	1.001	0.005	1.152	2.4409	0.005	0.709	0.945	2280	4800	0.61
			25.43	0.13	29.26	62	0.13	18	24	10000	21600	0.277
G206KRRB6	4	1	1.001	0.005	1.152	2.4409	0.005	0.709	0.945	2280	4800	0.59
			25.43	0.13	29.26	62	0.13	18	24	10000	21600	0.268
G207KPPB2	4	1 1/8	1.126	0.005	1.298	2.8346	0.005	0.748	1.484	3050	6400	1
			28.60	0.13	32.97	72	0.13	19	37.7	13700	28500	0.454
GW208KRRB5	4	1 1/4	1.251	0.005	1.443	3.1496	0.005	0.827	1.438	4000	8150	1.4
			31.77	0.13	36.65	80	0.13	21	36.51	17600	36000	0.635
GW208PPB22	2	1 1/4	1.255	0.005	1.447	3.1496	0.005	0.827	1.438	4000	8150	1.5
			31.88	0.13	36.75	80	0.13	21	36.51	17600	36000	0.68
GC1200KPPB2		1 3/4	1.751	0.005	2.020	3.9370	0.0006	0.984	2.250	4500	8800	3.35
			44.48	0.13	51.31	100	0.015	25	57.15	19600	39000	1.52

Light 200 Series

R-Seal Type
Special Sizes

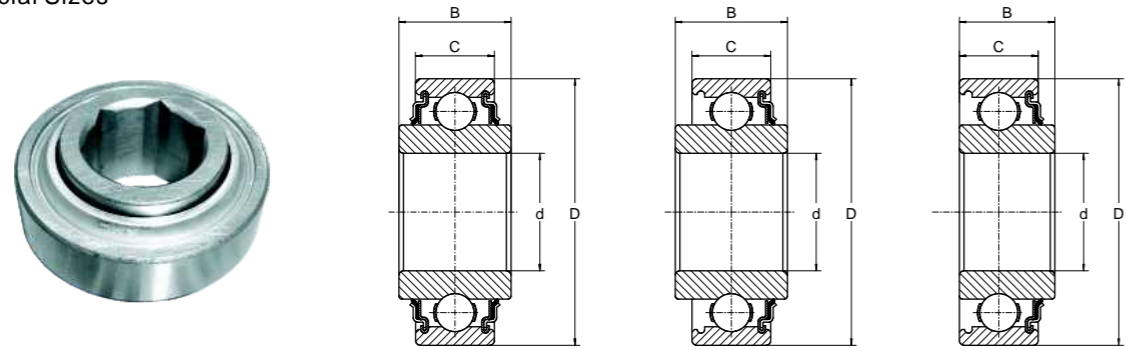

KML No.	Type	Bore D		Outside Diameter D		Ring Width B C		Static load rating Cor	Dynamic load rating Cor
		Tolerance +0.000* +0.000mm to minus		Tolerance +0.000* +0.000mm to minus		+0.000*, -0.005* +0.00, -12mm			
		In/mm	In/mm	In/mm	In/mm	In/mm	In/mm		
203KR2	3	0.6253 15.883	0.0003 0.0008	1.5748 40	0.0005 0.013	0.551 14.00	0.472 12	1000 4400	2360 10600
203KRR2	1	0.6400 16.256	0.0050 0.130	1.5748 40	0.0005 0.013	0.720 18.29	0.472 12	1000 4400	2360 10600
203KRR5	1	0.5150 13.081	0.0050 0.130	1.5748 40	0.0005 0.013	0.720 18.29	0.472 12	1000 4400	2360 10600
203KRR7	1	0.6693 17	0.0003 0.008	1.5748 40	0.0005 0.013	0.654 16.61	0.472 12	1000 4400	2360 10600
207KRR	1	1.3780 35	0.0005 0.013	2.8346 72	0.0005 0.013	0.984 25.00	0.669 17	3050 13700	6400 28500
208KRR2	1	1.5748 40	0.0005 0.013	3.1496 80	0.0005 0.013	1.063 27.00	0.827 21	4000 17600	8150 36000

CS 200 DDU Series
Ball bearings
Spherical O.D.

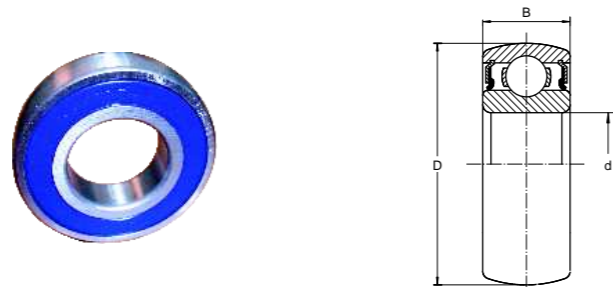

KML No.	Shaft Dia. mm	Boundary dimensions mm		Basic load ratings kg		Mass kg
		D	B	Dynamic Cr	Static Cor	
CS203 DDU	17	40	12	780	454	0.065
CS204 DDU	20	47	14	1010	630	0.11
CS205 DDU	25	52	15	1100	710	0.18
CS206 DDU	30	62	16	1550	1020	0.20
CS207 DDU	35	72	17	2030	1400	0.30
CS208 DDU	40	80	18	2300	1600	0.37
CS209 DDU	45	85	19	2570	1810	0.43
CS210 DDU	50	90	20	2760	2010	0.46
CS211 DDU	55	100	21	3400	2550	0.62
CS212 DDU	60	110	22	4100	3150	0.80

Special Size
Ball Bearings

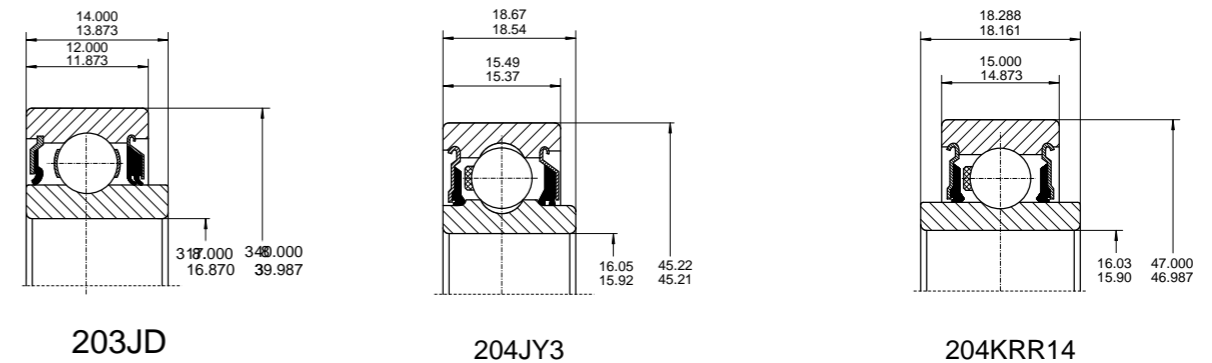
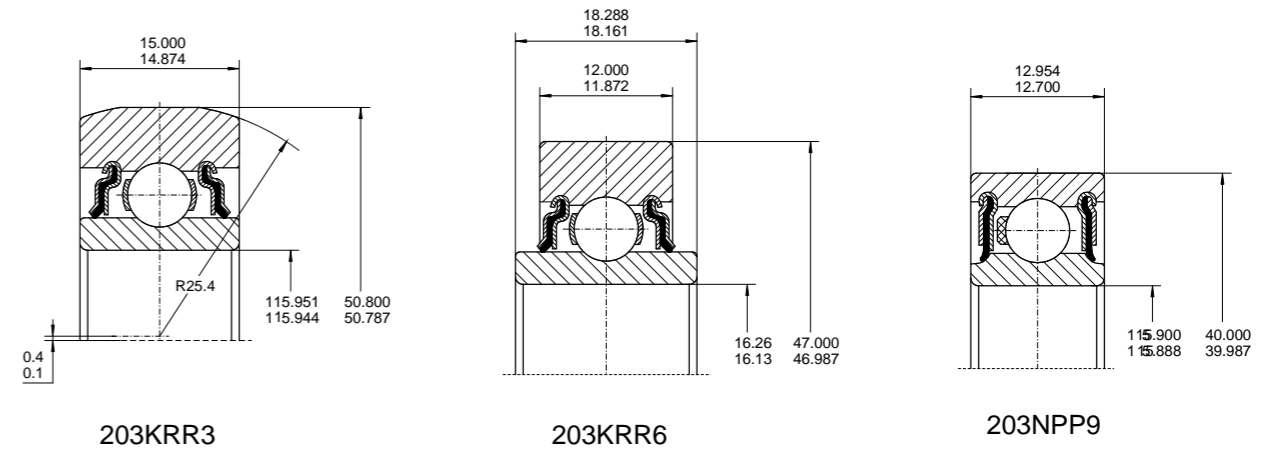
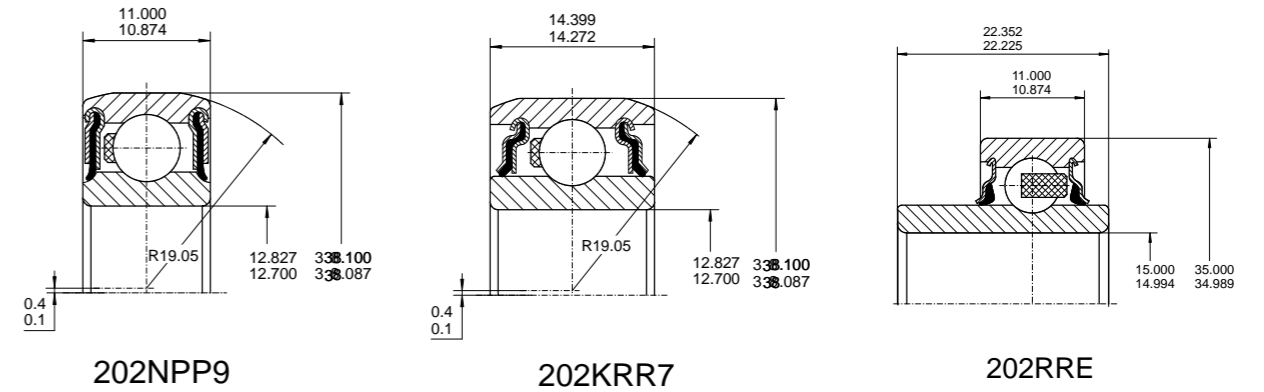

Special Size Ball Bearings

Special Size Ball Bearings

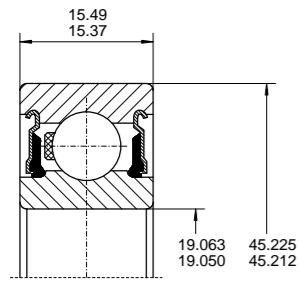

204RR6

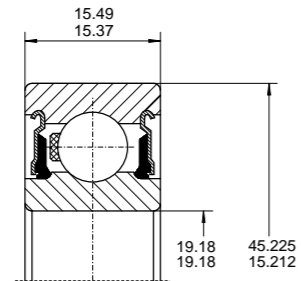

204RR7

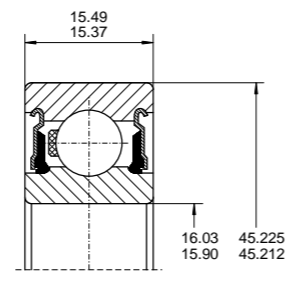

204RR8

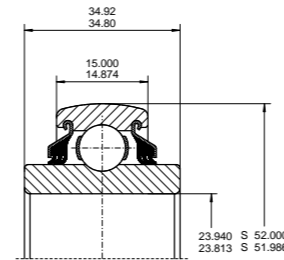

205PPB7

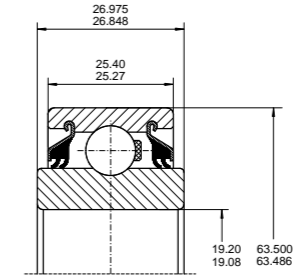

205KYY3

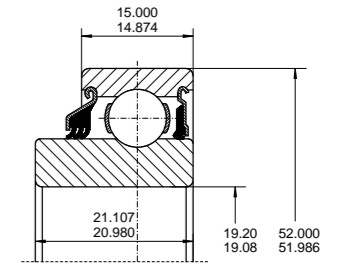

205KRP2

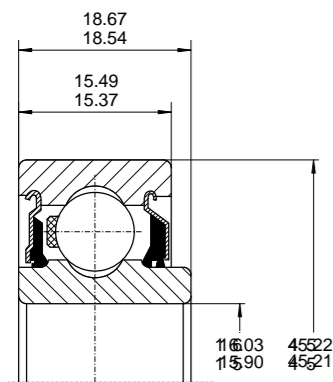

204RY2

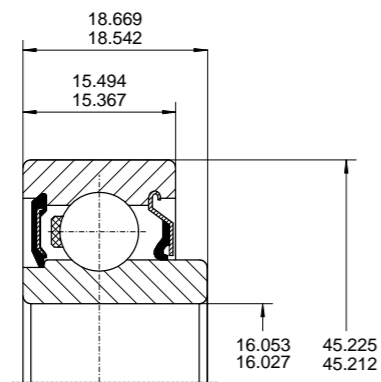

204-FREN

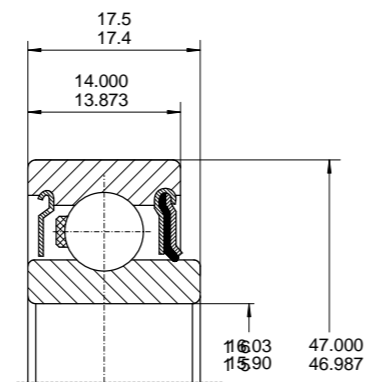

204KRD4

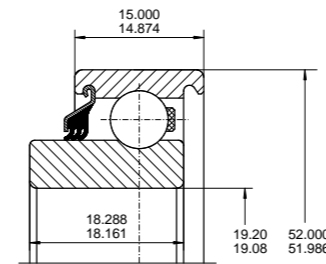

205KP8

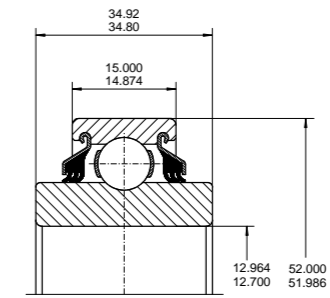

205PP8

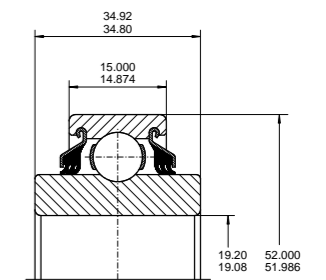

205PP9

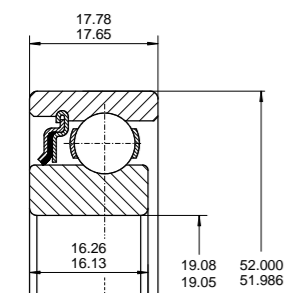

205KR3

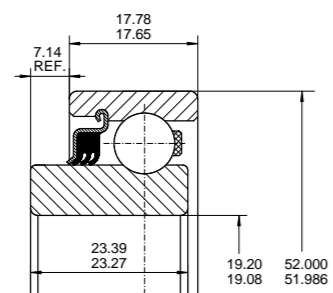

205KP6

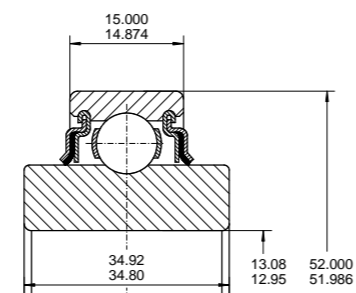

205KRR6

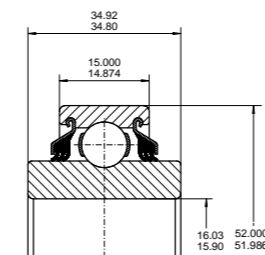

205PP10

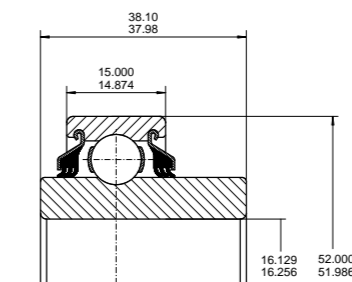

205PP12

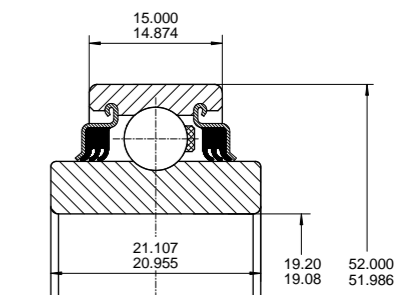

205E-2RST



Special Size Ball Bearings

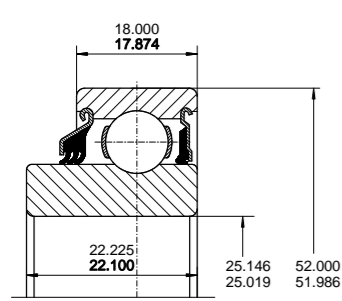

206KRP4

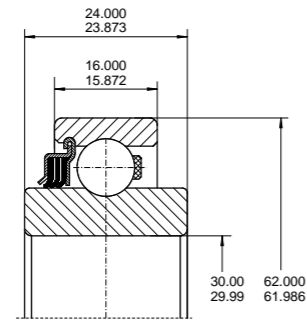

206KP2

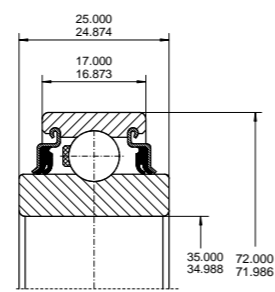

207KYY

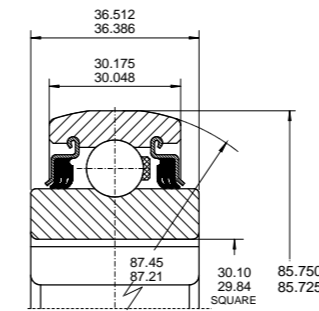

W208PPB12

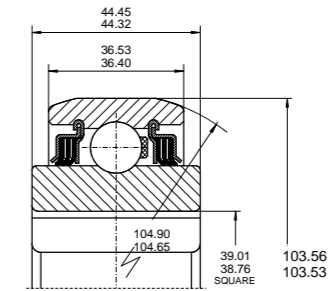

W211PPB6

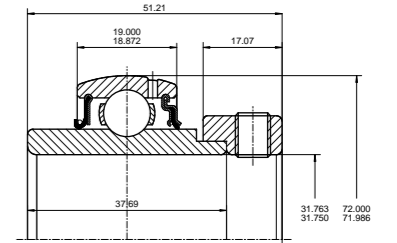

G1104KRXB2

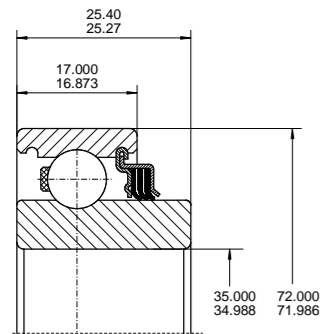

207KP2

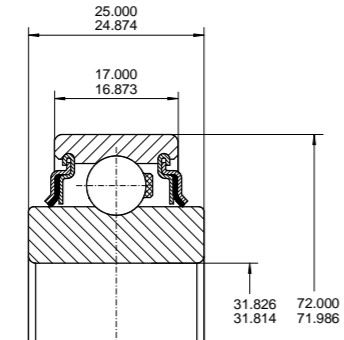

207KRR14

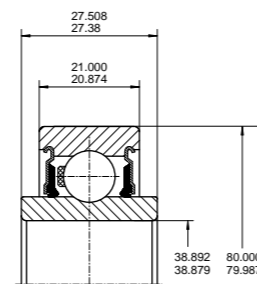

208KR4

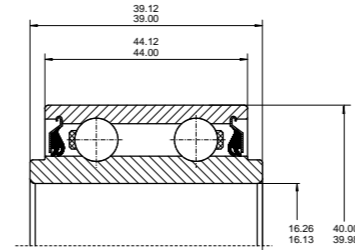

5203KYY2

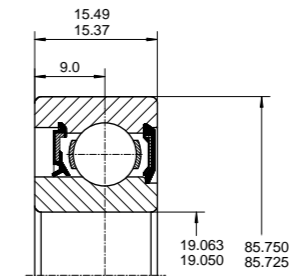

Z9504AB

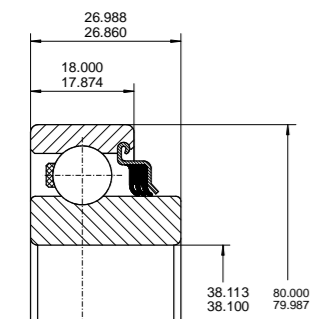

208KP2

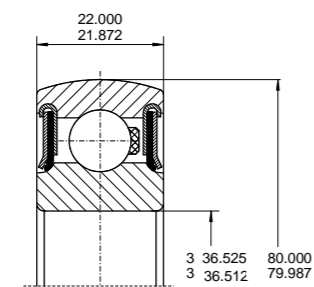

208NPPB5

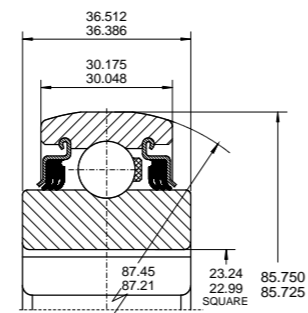

W208PPB11

Pressed Steel Housing

PP200 series
Pillow Blocks housing - Snap Together
standard steel pillow block sets

KML No.	Boundary dimensions mm							
	Da	h	a	e	b	S	w	g
PP203	40	22.2	86	68	25	9.5	43.8	3.2
PP204	47	25.4	98	76	32	9.5	50.5	3.2
PP205	52	28.6	108	86	32	11.5	56.6	4
PP206	62	33.3	117	95	38	11.5	66.3	4
PP207	72	39.7	129	106	42	11.5	78	4.6

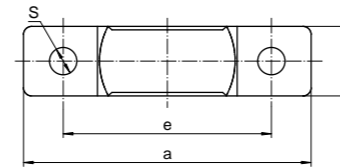
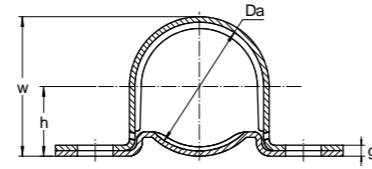

Pressed Steel Housing

PP200ST series
Pillow Blocks housing - Snap Together
Heavy duty steel pillow block sets

KML No.	Boundary dimensions mm									
	Da	h	a	e	b	S1	S2	w	g	
PP203ST	40	22.22	92	68	25	9	13	44	4	
PP204ST	47	25.40	105	76	25	10	13	53	4	
PP205ST	52	28.58	109	86	29	10	14	56	5	
PP206ST	62	33.34	124	95	32	10	14	67	6	
PP207ST	72	39.69	146	108	33	13	19	79	6	

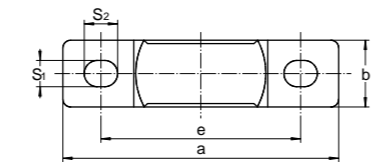
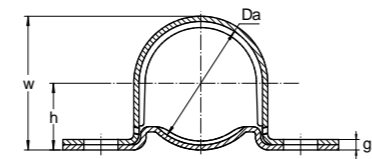

Standard Stock Item is Snap Together Type and Zinc Plated.

Pressed Steel Housing

PFL200 series
Two-Bolt Flange housings

KML No.	Boundary dimensions mm								Bolt size	Radial load ratings lbs	FAFNIR	SKF	NTN
	Da	b	a	e	c	s	f	g					
PFL203	40	58.7	81	63.5	7.1	7.1	49.2	1.9	1/4 M6	600	40MST	FT-40	PFL203
PFL204	47	66.7	90.5	71.4	7.9	8.7	55.6	2.1	5/16 M8	700	47MST	FT-47	PFL204
PFL205	52	71	95.3	76.2	8.7	8.7	60.3	2.1	5/16 M8	800	52MST	FT-52	PFL205
PFL206	62	84.1	112.7	90.5	8.7	10.3	71.4	2.6	3/8 M10	1100	62MST	FT-62	PFL206
PFL207	72	93.7	125.4	100.1	11.1	10.3	81	2.6	3/8 M10	1400	72MST	-	PFL207

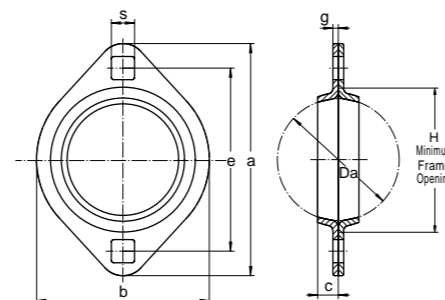

Standard Stock Item is Zinc Plated.

Pressed Steel Housing
PF200 series
Round Flange Housings

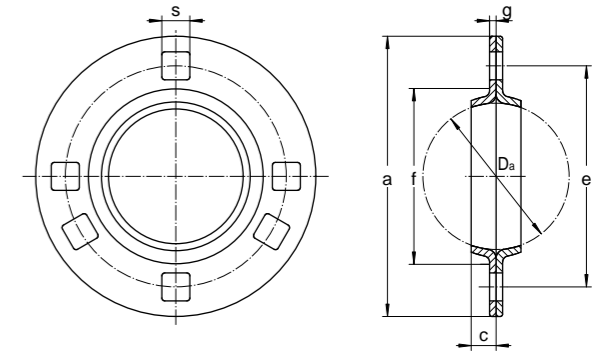

PF203 - PF207
Three Holes

PF208 - PF211
Four Holes

KML No.	Boundary dimensions mm							Bolt Size	FAFNIR	SKF	MRC	New departure
	a Flange Dia.	e Bolt Hole Circle Dia.	g Stock Thickness	s Hole Width	c Flange Shoulder Width	f Minimum frame opening						
PF203	81	63.5	1.9	7.1	7.1	49.2	1/4 M6	40MS	F-40	-	-	
PF204	90.5	71.4	2.1	8.7	7.9	55.6	5/16 M8	47MS	F-47	47MS-3	FL47	
PF205	95.3	76.2	2.1	8.7	8.7	60.3	5/16 M8	52MS	F-52	52MS-3	FL52	
PF206	112.7	90.5	2.6	10.3	8.7	71.4	3/8 M10	62MS	F-62	62MS-3	FL62	
PF207	122.2	100.12	2.6	10.3	9.5	81	3/8 M10	72MS	F-72	72MS-3	FL72	
PF208	147.6	119.1	3.4	13.5	10.3	90.5	1/2 M14	80MS	F-82	80MS	FL82	
PF209	149.2	120.7	3.4	13.5	11.1	96.8	1/2 M14	85MS	F-85	85MS	FL85	
PF210	155.6	127	3.8	13.5	11.1	101.6	1/2 M14	90MS	F-90	90MS	FL90	
PF211	166.7	138.1	3.8	13.5	11.9	112.7	1/2 M14	100MS	-	-	FL100	

Standard Stock Item is Zinc Plated.

Pressed Steel Housing
PF200G, PF200GP series
Round Flange Housings
Three-Bolt flange Housings

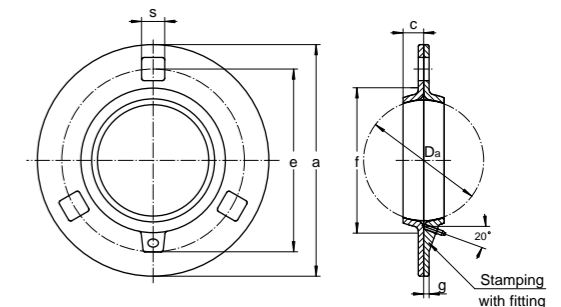

Hole width (SQ) tolerance 0.13mm

KML No.	Flange without fitting	Boundary dimensions mm						Bolt Size
		a Flange Dia.	e Bolt Hole Circle Dia.	g Stock Thickness	s Hole Width	c Flange Shoulder Width	f Minimum frame opening	
PF204G	PF204GP	90.5	71.4	2.1	8.7	7.9	55.6	5/16 M8
PF205G	PF205GP	95.2	76.2	2.1	8.7	8.7	60.3	5/16 M8
PF206G	PF206GP	112.7	90.5	2.6	10.3	9.5	71.4	3/8 M10
PF207G	PF207GP	122.2	100.1	3.4	10.3	11.1	81	3/8 M10
PF208G	PF208GP	147.6	106	3.8	13.5	15.9	90.5	1/2 M14
PF209G	PF209GP	149.2	120.7	3.8	13.5	15.9	96.8	1/2 M14
PF210G	PF210GP	155.6	127	4.2	13.5	16.7	101.6	1/2 M14
PF211G	PF211GP	166.7	138.1	4.2	13.5	16.7	112.7	1/2 M14

Standard Stock Item is Zinc Plated.

Pressed Steel Housings
PFT200 series
 Triangular Three-bolt Flanges Housings

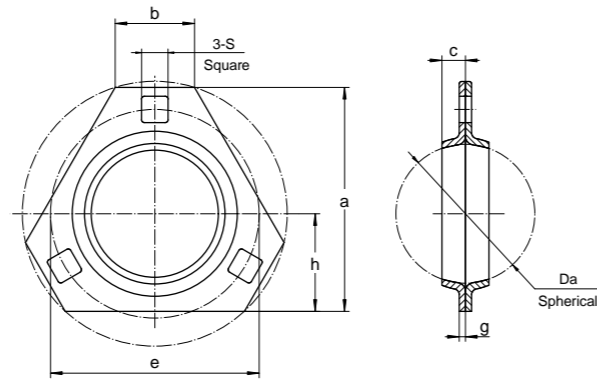

KML No.	Boundary dimensions mm								
	Da	a	e	g	s	c	h	b	Minimum frame opening
PFT203	40	69.1	63.5	1.9	7.1	7.1	28.6	20.6	48.2
PFT204	47	76.2	71.4	2.1	8.7	7.9	33.3	27	55.6
PFT205	52	79.4	76.2	2.1	8.7	8.7	34.9	27.8	60.3
PFT206	52	93.7	90.5	2.6	10.3	8.7	38.1	25.4	71.4
PFT207	72	105.6	100.1	2.6	10.3	9.5	44.5	32.1	81

Standard Stock Item is Zinc Plated.

Interchange

KML	PEER	FAFNIR	BCA	LINK-BELT	NTN	RHP
202NPP9 202RRE	202NPP9 202RRE	202NPP9 J202KRR8	202FFH8 202KRR8			
203JD 203KRR2 203KRR3 203KRR5	203JD 203KRR3 203KRR5	 203KRR2 203KRR3 203KRR5	203K 203RRAR10 8984YY 203RRAR8		5X0366LUL BS226119	
204FREN 204KDR4 204RY2	 204KRD4 204JY3	 204KRD4 204RY2	 204FGB 204FVMN			
205E-2RST 205KPPB2 205KR3 205KRR2 205KRRB2 205PPB7 205RTAN	 205KPPB2 205KR3 205KRR2 205KRRB2 205PPB7	 205KR3 205KRR2 205KRRB2 205PPB7	 205RHN HPC014GP HPS014GP 205TTH		14KB205N 14K205N BS217948N	1AH05-7/8 2AH05-7/8
206KRR6 206KRRB6	206KRR6 206KRRB6	206KRR6 206KRRB6	HPC100GP HPS100GP	16KB206N 16K206N	1AH06-1 2AH06-1	
499502H 99502H CF5202-2RST-8						DF0109LLPK1
CS202DDU CS203DDU CS204DDU CS205DDU CS206DDU CS207DDU CS208DDU CS209DDU CS210DDU		202NPPB 203NPPB 204NPPB 205NPPB 206NPPB 207NPPB 208NPPB 209NPPB 210NPPB	S202FF S203FF S204FF S205FF S206FF S207FF S208FF S209FF S210FF		CS202LLU CS203LLU CS204LLU CS205LLU CS206LLU CS207LLU CS208LLU CS209LLU CS210LLU	1726203-2RS 1726204-2RS 1726205-2RS 1726206-2RS 1726207-2RS 1726208-2RS 1726209-2RS 1726210-2RS
CS304DDU CS305DDU CS306DDU CS307DDU CS308DDU CS309DDU CS310DDU		304NPPB 305NPPB 306NPPB 307NPPB 308NPPB 309NPPB 310NPPB	S304FF S305FF S306FF S307FF S308FF S309FF S310FF		CS304LLU CS305LLU CS306LLU CS307LLU CS308LLU CS309LLU CS310LLU	1726304-2RS 1726305-2RS 1726306-2RS 1726307-2RS 1726308-2RS 1726309-2RS 1726310-2RS
G207KPPB2 G207KPPB3	G207KPPB2	G207KPPB2	HPS102TR			G207KPPB3
G209KPPB2	G209KPPB2					
GW208PP17 GW208PPB5 GW208PPB6 GW208PPB8	GW208PP17 GW208PPB5 GW208PPB6 GW208PPB8	GW208PP17 GW208PPB5 GW208PPB6 GW208PPB8	DS208TTR17 DS208TTR21 DS208TTR6 DS208TTR8	18SG7-2E08E3 16SG7-208E3 18SG2-2E08E3	1AS08-1 5/32D1 2AS08-1 1/8 D1	
GW209PPB11 GW209PPB2 GW209PPB4	GW209PPB11 GW209PPB2 GW209PPB4	GW209PPB11 GW209PPB2 GW209PPB4	DS209TTR10 DS209TTR2 DS209TTR4	RG3-209E3 24RG3-209E3	1AC09D1V1 3AC09D1 3AC09 1 1/2 D1	
GW210PP4 GW210PPB2 GW210PPB4 GW210PPB5	GW210PP4 GW210PPB2 GW210PPB4 GW210PPB5	GW210PP4 GW210PPB2 GW210PPB4 GW210PPB5	DC210TTR4 DS210TTR2 DS210TTR4 DS210TTR5R	18SBG3-210ES 31RG3-210E3 18SG3-210E3 28RG3-210E3	7AS10-1 1/8 D1 3AC10-1 15/16 D1 3AC10-1 3/4 D1	
GW211PP17 GW211PP25	GW211PP17 GW211PP25	GW211PP17 GW211PP37	DC211TTR3E DC211TTR21			

Interchange

KML	PEER	FAFNIR	BCA	LINK-BELT	NTN
GW211PPB13	GW211PPB13	GW211PPB13	DS211TTR13		
GW211PPB2	GW211PPB2	GW211PPB2	DS211TTR2	35RG3-211E3	3AC11-2 3/16 D1
GW211PPB3	W211PPB3	W211PPB3	DS211TT3	24S3-211E3	3AS11-1 1/2
GW211PPB3	GW211PPB3	GW211PPB3	DS211TTR3	24SG3-211E3	3AS11-1 1/2 D1
GW211PPB9	GW211PPB9	GW211PPB9	DS211TTR9		
GW214PP2	GW214PP2	GW214PP2	DC214TTR2		
GW214PPB2	GW214PPB2	GW214PPB2			3AC14D1
GW214PPB3	GW214PPB3			DC214TTR3	
GW214PPB4	GW214PPB4	GW214PPB4			3AS14-2D1
GW214PPB6	GW214PPB6		DS214TTRA		
W208PP5	W208PP5	W208PP5	DC208TT5	18SB5-2E08E3	5AS08-1 1/8
W208PP6	W208PP6	W208PP6	DC208TT6	16SB5-208E3	
W208PPB13	W208PPB13	W208PPB13	DS208TT13	14S5-208E3	1AS08-7/8
W208PPB2	W208PPB2	W208PPB2		24R6-208E3	2AC08-1 1/2
W208PPB7	W208PPB7	W208PPB7	DS208TT7	19R208E3	1AC08-1 3/16
W208PPB8	W208PPB8	W208PPB8	DS208TT8	18S2-2E08E3	2AS08-1 1/8
W208PPB9	W208PPB9	W208PPB9	DS208TT9	16S2-208E3	2AS08-1 1/8
W209PPB2	W209PPB2	W209PPB2	DS209TT2	R3-209E3	
W209PPB4	W209PPB4	W209PPB4	DS209TT4	24R3-209E3	3AC09-1/2
W210PP2	W210PP2	W210PP2	DC21TT2	31RB3-210E3	7AC10-1 15/16
W210PP4	W210PP4	W210PP4	DC210TT4	18SB3-210E3	7AS10-1 1/8
W210PPB2	W210PPB2	W210PPB2	DS210TT2	31R3-210E3	3AC10-1 15/16
W210PPB4	W210PPB4	W210PPB4	DS210TT4	18S3-210E3	3AS10-1 3/4
W210PPB5	W210PPB5	W210PPB5	DS210TT5	28R3-210E3	3AC10-1 3/4
W210PPB6	W210PPB6	W210PPB6	DS210TT6	18S2-210ES	2AS10-1 1/8
W211PP2	W211PP2	W211PP2	DC211TT2	35RB3-211E3	7AC11-2 3/16
W211PP3	W211PP3	W211PP3	DC211TT3	24SB3-211E3	7AS11-1 1/2
W211PP5	W211PP5	W211PP5	DS211TT5		6AS11-1 1/2 V1
W211PPB2	W211PPB2	W211PPB2	DS211TT2	35R3-211E3	3AC11-2 3/16
W211PPB6	W211PPB6	W211PPB6	DS211TT6		4AS11-1 1/2
Z9504AB					
Z9504RST					
Z9504-RST	Z9504-2RST	P204RR6	204BBAR		SC045IIC3
ST491A	ST491A	491A	FD-209-RA		
ST491B	ST491B	DHU 1 1/2R-209	FD-209-RB		
DHU 1 1/8S-209	FD209-1 1/8SQ	DHU 1 1/8S-209	FD-209-RM		
DHU 1 3/4R-209	FD209-1 1/4SQ	DHU 1 3/4R-209	FD-209-RK		
DHU 1 1/4S-209		DHU 1 1/4S-209			
DHU 1 1/2S-211	FD211-1 1/2SQ	DHU 1 1/2S-211	FD-211-RM		
DHU 1 3/4R-211	FD211-1 3/4RD	DHU 1 3/4R-211	FD-211-RE		
DHU 2 3/16R-211	FD211-2 3/16RD	DHU 2 3/16R-211	FD-211-RB		
FD-211-RJA	FD211-1 15/16RDC		FD-211-RJA		
DHU 30S-209		DHU 30S-209			
DHU 40R-209		DHU 40R-209			
DHU 45R-209		DHU 45R-209			
DHU 40S-211		DHU 40S-211			
DHU 50R-211		DHU 50R-211			
DHU 55R-211		DHU 55R-211			
203KR2	203KR2	203KR2			
203KRR2	203KRR2	203KRR2			
203KRR5	203KRR5	203KRR5			
203KRR7	203KRR7	203KRR7			
207KRR	207KRR	207KRR			
208KRR2	208KRR2	208KRR2			

Contact List

KML Bearing and Equipment Limited

Address: Flat 5-7, 26th Floor, Saxon Tower, 7 Cheung Shun Street, Kowloon, Hong Kong, China
 Phone: 852-2425-1661
 Fax: 852-2480-5866
 E-mail: info@kml-bearing.com
 Web: www.kml-bearing.com

KML Powertrans Inc.

• **Guangzhou, China**
 Address: Rm 05-06, Floor 17A, Bank of China Building, 338 Qinghe Rd E., Guangzhou, China
 Phone: 86-20-8469-8686
 Fax: 86-20-8469-8689
 E-mail: info@kml-bearing.com
 Web: www.kml-bearing.com

• **Shanghai, China**

Address: Room H, Floor 20, JinXuan Building, 238 Nandan Road East, Shanghai, China
 Phone: 86-21-6438-8110
 Fax: 86-21-6427-6197

KML PowerTech Ltd.

Address: No.2 Jingliu Road, Luolong Science and Technology District, Luoyang City, Henan Province, China
 Phone: 86-379-6861-3988
 Fax: 86-379-6861-3969
 E-mail: info@kml-bearing.com
 Web: www.kml-powertech.com

KML Bearing Canada Inc.

• **Mississauga, Canada**
 Address: 5586-5592 Ambler Dr., Mississauga, Ontario, L4W 2K9, Canada
 Phone: 1-800-565-0044
 Fax: 1-905-629-2358
 E-mail: info@kml-bearing.com
 Web: www.kml-bearing.com

• **Montreal, Canada**

Address: 561 Orly Ave, Dorval, Quebec, H9P 1G1, Canada
 Phone: 1-514-636-1777
 Fax: 1-514-636-1519
 E-mail: info@kml-bearing.com
 Web: www.kml-bearing.com

• **Edmonton, Canada**

Address: 4525 – 101 Street, Edmonton, Alberta, T6E 5C6, Canada
 Phone: 1-780-433-6797
 Fax: 1-780-433-6157
 E-mail: info@kml-bearing.com
 Web: www.kml-bearing.com

KML Bearing USA, Inc.

Address: 213 Jones Blvd., P.O. Box 1136, Pottstown, PA 19464, USA
 Phone: 610-495-6134, 877-495-6134 (toll free)
 Fax: 610-495-6183
 E-mail: info@kml-bearing.com
 Web: www.kml-bearing.com