

# KDF®



## SUPPORTI AUTOALLINEANTI SELF-ALIGNING BEARING UNITS



CATALOGO TECNICO GENERALE  
GENERAL TECHNICAL CATALOGUE  
1.11.06



**Supporti autoallineanti**  
***Self-aligning bearing units***



**DISPONIBILI SUPPORTI PER ALTE TEMPERATURE**  
**HIGH TEMPERATURES BEARING UNITS AVAILABLE**

**S u p p o r t i I N O X**  
***Stainless steel bearing units***



**Supporti in plastica**  
***Plastic bearing units***



■ SEDE PRINCIPALE  
HEAD OFFICE

■ MAGAZZINO  
WAREHOUSE

■ UFFICIO COMMERCIALE  
SALES DEPARTMENT



**ITALCUSCINETTI** S.p.A.  
forniture industriali  
industrial supplies

COMPANY  
WITH QUALITY SYSTEM  
CERTIFIED BY DNV  
=ISO 9001/2000=

IMPORTATORE - DISTRIBUTORE ESCLUSIVISTA PER L'EUROPA  
IMPORTER - DISTRIBUTOR EUROPEAN SOLE AGENT\*



CUSCINETTI  
BEARINGS



CUSCINETTI  
PER APPLICAZIONI  
"BASSA RUMOROSITA"  
BEARINGS FOR  
"LOW NOISE" APPLICATIONS



CUSCINETTI A RULLINI  
NEEDLE BEARINGS



COMPONENTI PER LA  
MOVIMENTAZIONE LINEARE  
COMPONENTS FOR  
LINEAR MOTION



SUPPORTI  
AUTOALLINEANTI  
SELF-ALIGNING  
BEARING UNITS



SUPPORTI  
AUTOALLINEANTI  
SELF-ALIGNING  
BEARING UNITS



TESTE A SNODO - SNODI SFERICI  
ROD ENDS - SPHERICAL  
PLAIN BEARINGS



BOCCOLE AUTOLUBRIFICANTI  
E SINTERIZZATE  
SELF-LUBRICATING  
AND SINTERED BUSHES



CATENE  
CHAINS



CUSCINETTI  
BEARINGS

**EURO TRASMISSIONI** (Divisione commerciale della Italcuscineti S.r.l.)

Italcuscineti S.r.l. - Via Caponnetto, 15 - 42048 RUBIERA (Reggio Emilia) - Italia  
Vendite Italia Tel. 0039 0522 621811 - Fax 0039 0522 628926 - E-mail: comm.it@italcuscineti.it  
Export sales dept. Tel. 0039 0522 621830 - Fax 0039 0522 626149 - E-mail: export@italcuscineti.it  
Import dept. Tel. 0039 0522 621880 - Fax 0039 0522 629255 - E-mail: import@italcuscineti.it  
Internet: [www.italcuscineti.it](http://www.italcuscineti.it) - E-mail: [info@italcuscineti.it](mailto:info@italcuscineti.it)

## Programma Generale di Vendita - General Sales Program



CUSCINETTI \*  
BEARINGS \*



TSC®

SUPPORTI AUTOALLINEANTI  
SELF-ALIGNING BEARING UNITS

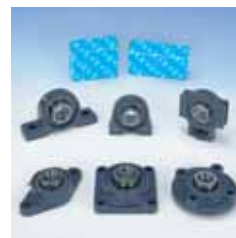

EMS®

CUSCINETTI PER APPLICAZIONI "BASSA RUMOROSITÀ" \*  
BEARINGS FOR "LOW NOISE" APPLICATIONS \*



TESTE A SNODO - SNODI SFERICI \*  
ROD ENDS - SPHERICAL PLAIN BEARINGS \*



CUSCINETTI A RULLINI \*  
NEEDLE BEARINGS \*



BOCCOLE AUTOLUBRIFICANTI E SINTERIZZATE \*  
SELF-LUBRIFICATING AND SINTERED BUSHES \*



COMPONENTI PER LA MOVIMENTAZIONE LINEARE \*  
COMPONENTS FOR LINEAR MOTION \*



CATENE \*  
CHAINS \*



KDF®

SUPPORTI AUTOALLINEANTI \*  
SELF-ALIGNING BEARING UNITS \*



Disponibile grande assortimento completo  
con pronta consegna.

Big and full assortment with prompt  
delivery.

CUSCINETTI SKF E FAG  
SKF AND FAG BEARINGS



\* Per ulteriori informazioni, potete richiedere il  
Catalogo Tecnico

\* For further information, please ask for the  
Technical Catalogue



Titolo	Pag.	Title	Pag.
<b>1. Struttura supporti</b>	<b>I</b>	<b>1. Structure of bearing units</b>	<b>I</b>
1.1 KDF® marchio sinonimo di qualità	II	1.1 KDF® is a trademark which identifies quality	II
<b>2. Caratteristiche tecniche costruttive</b>	<b>II</b>	<b>2. Technical constructive characteristics</b>	<b>II</b>
2.1 Materiale dei cuscinetti	III	2.1 Material of bearings	III
2.2 Materiale delle gabbie e dei rivetti	IV	2.2 Material of the cages and the rivets	IV
2.3 Materiale del corpo	IV	2.3 Material of housing	IV
2.4 Materiali degli altri componenti	V	2.4 Material of other components	V
2.5 Tenute e protezioni	VI	2.5 Seals and covers	VI
<b>3. Tolleranze e simboli</b>	<b>VI</b>	<b>3. Symbols and tolerances</b>	<b>VI</b>
3.1 Tolleranze dei supporti	IX	3.1 Bearing units tolerances	IX
3.2 Tolleranze dei supporti ritti	X	3.2 Pillow block units tolerances	X
3.3 Tolleranze dei supporti flangiati	XI	3.3 Flange bearing units tolerances	XI
3.4 Tolleranze dei supporti scorrevoli ed a cartuccia	XII	3.4 Take-up and cylindrical cartridge bearing units tolerances	XII
3.5 Tolleranze degli alberi	XIII	3.5 Shafts tolerances	XIII
3.6 Precisione dimensionale delle fusioni	XIV	3.6 Dimensional accuracies of castings	XIV
3.7 Tolleranze delle fusioni	XIV	3.7 Castings tolerances	XIV
3.8 Carico ammissibile dei supporti	XV	3.8 Allowed load of housings	XV
3.9 Carico ammissibile dei supporti in lamiera stampata	XVI	3.9 Allowed load of pressed housings	XVI
3.10 Coefficiente di sicurezza	XVI	3.10 Safety factor	XVI
3.11 Velocità massima (giri al minuto)	XVII	3.11 Max rpm.	XVII
<b>4. Coefficienti di carico e durata</b>	<b>XVII</b>	<b>4. Load ratings and life</b>	<b>XVII</b>
4.1 Coefficiente di carico statico Co	XX	4.1 Static load ratings Co	XX
4.2 Coefficiente di sicurezza statico So	XX	4.2 Static load safety factor So	XX
4.3 Carico radiale dinamico e statico equivalente	XXI	4.3 Equivalent radial dynamic and static load	XXI
<b>5. Giuoco dei cuscinetti a sfere</b>	<b>XXI</b>	<b>5. Clearance of ball bearings</b>	<b>XXI</b>
5.1 Tipologia giuoco radiale	XXII	5.1 Types of radial clearance	XXII
<b>6. Lubrificazione</b>	<b>XXIV</b>	<b>6. Lubrication</b>	<b>XXIV</b>
6.1 Supporti esenti da manutenzione	XXIV	6.1 Maintenance-free bearing units	XXIV
6.2 Supporti ri-lubrificabili	XXV	6.2 Re-greaseable bearing units	XXV
6.3 Periodicità della lubrificazione	XXV	6.3 Periodicity of lubrication	XXV
6.4 Accorgimenti per la lubrificazione	XXVI	6.4 Rules for lubrication	XXVI
6.5 Quantità di grasso	XXVII	6.5 Grease quantity	XXVII
6.6 Ingrassatori	XXVIII	6.6 Grease nipple	XXVIII
6.7 Tabella dei lubrificanti	XXIX	6.7 Tables of lubricants	XXIX
<b>7. Montaggio e smontaggio</b>	<b>XXX</b>	<b>7. Mounting and disassembly</b>	<b>XXX</b>
7.1 Fissaggio con grani	XXX	7.1 Setscrews fixing	XXX
7.2 Fissaggio con bussola di trazione	XXXII	7.2 Taper adapter fixing	XXXII
7.3 Fissaggio con anello eccentrico di serraggio	XXXIII	7.3 Eccentric collar locking fixing	XXXIII
7.4 Movimento assiale dovuto all'espansione o al restringimento	XXXIV	7.4 Axial movement due to expansion and shrinkage	XXXIV
7.5 Smontaggio del supporto	XXXV	7.5 Disassembly of bearing unit	XXXV
7.6 Sostituzione del cuscinetto	XXXV	7.6 Bearing replacement	XXXV
<b>8. Tabella conversione durezza</b>	<b>XXXVI</b>	<b>8. Conversion table of hardness</b>	<b>XXXVI</b>
<b>9. Tabella conversione pollici/millimetri</b>	<b>XXXVII</b>	<b>9. Conversion table of inch/millimetres</b>	<b>XXXVII</b>
<b>10. Tabella d'intercambiabilità</b>	<b>XXXVIII</b>	<b>10. Interchangeability table</b>	<b>XXXVIII</b>
<b>11. Tipologia dei supporti e cuscinetti KDF®</b>	<b>XXXX</b>	<b>11. KDF® Bearing units and bearings type</b>	<b>XXXX</b>
<b>12. Indice generale dei prodotti KDF®</b>	<b>XXXXI</b>	<b>12. KDF® Products general index</b>	<b>XXXXI</b>





## 1. STRUTTURA SUPPORTI

## 1. STRUCTURE OF BEARING UNITS

# KDF®

**Ingrassatore per lubrificazione**  
*Grease nipple for lubrication*

**Doppia tenuta: lamierino di protezione  
più tenuta in gomma**  
*Double protection: combination of  
steel and rubber seal*

**Foro di fissaggio del supporto**  
*Self-aligning bearing  
units fixing hole*

**Anello interno temperato e rettificato**  
*Hardned ground inner ring*

**Superficie sferica orientabile**  
*Self-aligning surface*

**Grano di fissaggio fornibile anche  
con bussola o collare eccentrico  
di fissaggio**  
*Set screw fixing also available  
with eccentric collar or tapered  
adapter sleeve*

**Corona a un giro di sfere**  
*Single row deep groove  
ball bearing*

**Supporto monoblocco in ghisa**  
*One-piece cast iron housing*

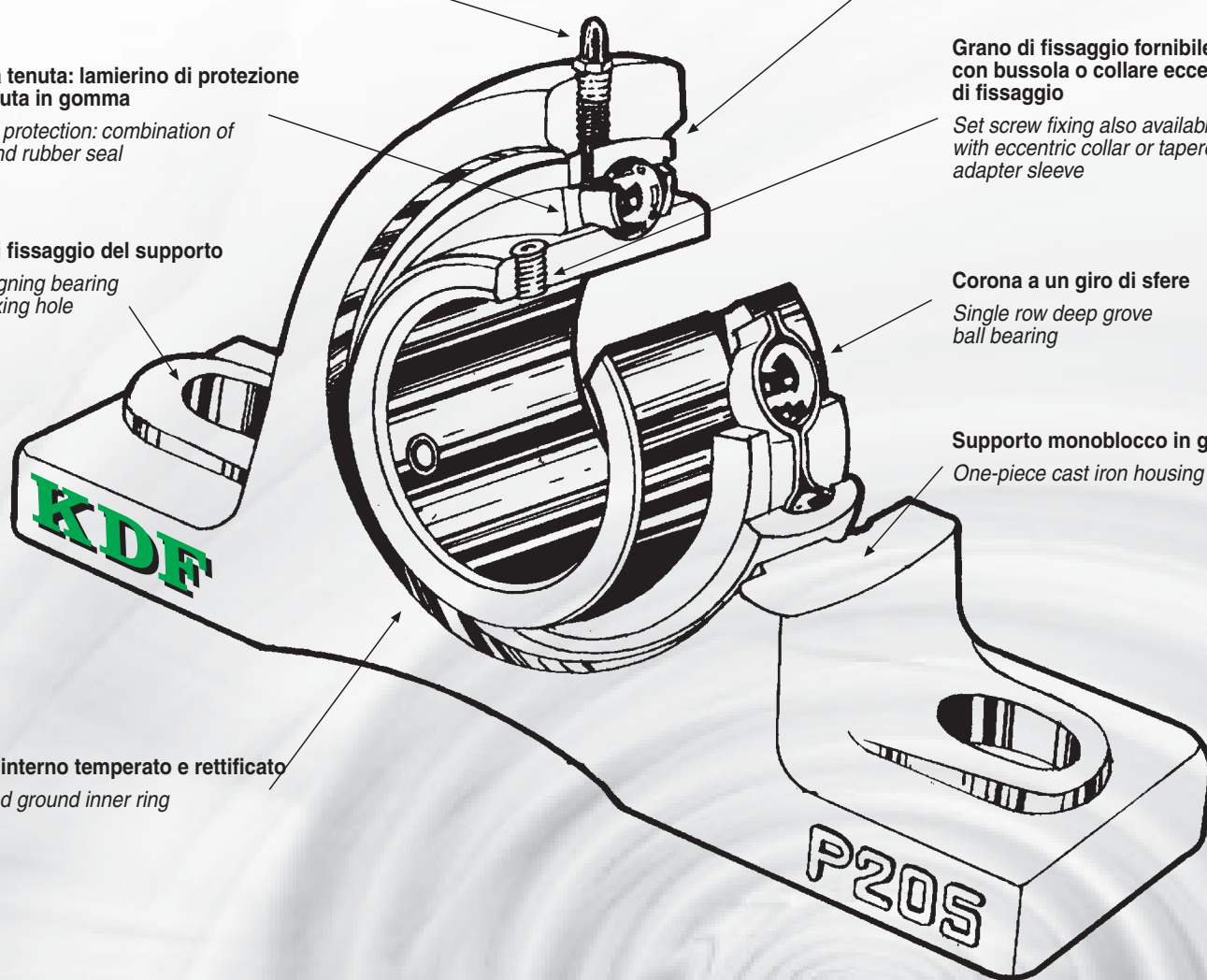

## 1.1 KDF® MARCHIO SINONIMO DI QUALITÀ

Il marchio **KDF®**, rappresenta una gamma d'articoli tecnici la cui produzione viene affidata ad un pool di costruttori, che hanno saputo mettere a frutto l'esperienza maturata da ormai diversi decenni nel settore. L'elevato know-how tecnico insieme ad apparecchiature d'alto livello sono in grado di garantire una produzione con standard di qualità elevati, sia per ciò che concerne le fasi di produzione, che il controllo dei prodotti finiti. All'interno di questo catalogo tecnico viene illustrata la gamma dei prodotti; inoltre si ricorda che per applicazioni speciali è possibile contattare l'ufficio tecnico.

Lo scopo principale di questo catalogo tecnico è di aiutare i progettisti, cercando di fornire loro le informazioni necessarie per trovare le migliori applicazioni e soluzioni possibili per ciò che riguarda le attività di loro competenza. La prima parte del catalogo tecnico, illustra le caratteristiche tecniche generali di tutti i supporti in ghisa e dei cuscinetti **KDF®** (caratteristiche costruttive, tolleranze, coefficienti di carico e durata, giuoco del cuscinetto, lubrificazione, ed altre informazioni di vario genere), a seguito vengono indicate le tabelle dimensionali dei prodotti. Nella seconda parte del catalogo, sono illustrate le caratteristiche e le tabelle dimensionali dei supporti della serie pesante, dopodiché nella terza parte si passerà ai supporti in plastica. Tutte le caratteristiche tecniche di costruzione, sono in accordo con le norme ISO e DIN, questo per garantire un prodotto d'elevata qualità, che mantenga le medesime caratteristiche nel tempo e che sia intercambiabile con i marchi più prestigiosi a livello mondiale.



## 2. CARATTERISTICHE TECNICHE COSTRUTTIVE

I supporti **KDF®** sono costruiti in molteplici esecuzioni, con corpo esterno in ghisa, in lega d'alluminio, in lamiera d'acciaio stampato ed in plastica. I supporti sono forniti completi di cuscinetto, dotato di anello esterno sferico che può oscillare nella corrispondente pista ricavata nel supporto, in modo tale da compensare qualsiasi difetto d'allineamento, eliminando le sollecitazioni tra albero e supporto. Il cuscinetto inserito nell'alloggiamento del supporto, è corrispondente per le sue caratteristiche costruttive interne ai cuscinetti della serie 62 o 63 secondo le tabelle ISO.

## 1.1 KDF® IS A TRADEMARK WHICH IDENTIFIES QUALITY

*The **KDF®** trademark represents a range of technical articles, the production of which is entrusted to a pool of constructors who, exploit their several decades of experience in the sector. High level technical know-how together with advanced equipment guarantee elevated production standards both in the productive phase as well as the quality control phase on the finished product. This technical catalogue illustrates our range of products; though special applications are possible by contacting our technical office as well.*

*The principal objective of this technical catalogue is to help project managers by furnishing them with the necessary information to find the best applications and solutions possible for the activity of their competence. The first part of this technical catalogue illustrates the general technical characteristics of all the housings in cast iron and the **KDF®** ball bearings (constructive characteristics, tolerances, load and duration coefficients, clearance of the ball bearing, lubrication and various other general information), followed by tables with the sizes of the products. In the second part of the catalogue the characteristics are illustrated in the tables the sizes of the heavy series housings are listed, after which is the third part which moves to the plastic housings.*

*All of the technical characteristics of construction are in accordance with ISO and DIN rules, in order to guarantee an elevated product which maintains the same characteristics over time and is interchangeable with more well known brands on a world wide level.*

## 2. TECHNICAL CONSTRUCTIVE CHARACTERISTICS

***KDF®** housings are constructed in multiple executions, with external parts in cast iron, bound with aluminium, in moulded steel sheets and in plastic.*

*The housing units are supplied complete with ball bearing, provided with external ball rings which can oscillate in the corresponding track hollowed out in the casting, in such a way as to compensate for any defect of alignment, eliminating solicitation between the shaft and the prop. It corresponds to the internal constructive characteristics of the 62 or 63 series according to the ISO tables.*



Su entrambi i lati del cuscinetto, sono montate delle guarnizioni di tenuta, studiate e particolarmente indicate per garantire una perfetta tenuta ed evitare così eventuali infiltrazioni di polvere, umidità e fluidi di vario genere. Tutti i cuscinetti sono pre-ingrassati e ri-lubrificabili, fatta eccezione per le serie: CB - RB - SA - SB, che sono lubrificati per tutto l'arco della loro vita.

Nel caso che i supporti debbano essere utilizzati in condizioni particolarmente critiche, come in ambienti dove operano aziende agricole, siderurgiche, fonderie, tutti i supporti possono essere forniti di coperchi di protezione supplementare. I coperchi possono essere costruiti in ghisa grigia o in lamiera d'acciaio o in plastica e sono costituiti in modo tale da garantire anche un'eventuale sostituzione delle tenute in gomma, con comuni anelli in feltro. Esistono anche dei coperchi chiusi, utilizzabili in applicazioni ove l'albero non è passante.

*Specially studied and particularly indicated resistance gaskets are located on both sides of the ball bearing, to guarantee perfect resistance, this avoids eventual infiltration from dust, humidity and fluids of various types. All of the ball bearings are pre-lubricated and can be lubricated repeatedly, except the series: CB - RB - SA - SB, which are lubricated for their lifetime.*

*Should the housing be used in particularly critical conditions such as the ambient where agricultural companies or iron and steel foundries operate, all of the housings can be supplied with supplementary protective covers. The covers can be constructed in grey cast iron or in steel sheets or in plastic and are constructed in such a way as to guarantee even eventual substitution of rubber seals with common felt rings. There are also closed covers used in applications where the shaft does not pass.*

## 2.1 MATERIALE DEI CUSCINETTI

Il materiale delle piste di rotolamento e delle sfere dei cuscinetti, deve avere la necessaria durezza e mantenere le sotto indicate qualità:

1. elevata resistenza contro ripetuti sforzi, che possono causare fratture per affaticamento della superficie nelle piste di rotolamento, che regolano la vita del cuscinetto.
2. elevata resistenza ed elasticità dei materiali per prevenirne la deformazione, nel momento in cui sono applicati dei forti carichi sulla superficie.
3. elevata resistenza all'abrasione, per contrastare efficacemente l'attrito radente tra gabbia e sfere.
4. elevata resistenza contro rotture causate da urti, guasti e/o avarie per errate applicazioni o montaggi impropri.
5. piccoli cambiamenti che possono avvenire nel tempo, per quanto riguarda le dimensioni e la forma dovuti a sollecitazioni interne o variazioni di struttura.

GCr15 acciaio <JIS G4805> (acciaio con elevato contenuto di carbonio e cromo, per cuscinetti), questa tipologia d'acciaio è in grado di soddisfare quanto riportato nei punti precedenti, e la sua composizione chimica viene mostrata nella sotto indicata tabella.

## 2.1 MATERIAL OF BEARINGS

*The materials used to construct the rolling track and the bearing spheres must have the necessary hardness and maintain the qualities indicated below:*

1. *elevated resistance against repeated straining that can cause fractures due to wear and tear on the surface of the rolling track which regulates the life of the bearing.*
2. *elevated resistance and elasticity of the materials in order to prevent deformation when heavy loads are applied to the surface.*
3. *elevated resistance to abrasion to effectively contrast against wear and tear between the cage and the sphere.*
4. *elevated resistance against breaking caused by collision, breakage and or breakdown due to incorrect application or improper assemblage.*
5. *small changes which could occur over time due to internal solicitation or structural variations.*

*GCr15 steel <JIS G4805> (steel with and elevated carbon or chrome content for bearings), is type of steel which is capable of satisfying all of the above points and the chemical composition is shown in the table indicated below.*

**Composizione chimica dell'acciaio con elevato contenuto di carbonio e cromo per cuscinetti**  
*Chemical composition of high carbon chromium bearing steel*

Classificazione <i>Class</i>	Simboli <i>Symbols</i> <b>JIS</b>	Carbonio <i>Carbon</i> <b>C</b>	Silicio <i>Silicon</i> <b>Si</b>	Manganese <i>Manganese</i> <b>Mn</b>	Fosforo <i>Phosphorus</i> <b>P</b>	Zolfo <i>Sulphur</i> <b>S</b>	Cromo <i>Chromium</i> <b>Cr</b>
1	SUJ 1	0,95 ~ 1,10	0,15 ~ 0,35	> 0,50	> 0,025	> 0,025	0,90 ~ 1,20
2	SUJ 2	0,95 ~ 1,10	0,15 ~ 0,35	> 0,50	> 0,025	> 0,025	1,30 ~ 1,60
3	SUJ 3	0,95 ~ 1,10	0,40 ~ 0,70	0,9 ~ 1,15	> 0,025	> 0,025	0,90 ~ 1,20

Per mantenere costante la qualità nel tempo, vengono effettuati tutta una serie di controlli sotto riportati:

- analisi chimiche sulla composizione
- esplorazioni magnetiche
- prove di rumorosità e vibrazione
- corrosione da contatto con sostanze acide
- controlli visivi
- controlli della struttura al microscopio
- test di durezza dei materiali
- prove d'affaticamento

*In order to maintain the quality constant over time, the entire series of tests reported below are performed:*

- *chemical analysis of the composition.*
- *magnetic exploration*
- *noise and vibration tests*
- *corrosion from contact with acid substances.*
- *visual inspection*
- *microscopic inspection*
- *hardness tests on the materials*
- *stress tests*

## 2.2 MATERIALE DELLE GABBIE E DEI RIVETTI

La composizione del materiale di costruzione delle gabbie è conforme alle norme JIS G 3141; le gabbie sono costituite da lamine d'acciaio al carbonio rullato, raffreddato e pressato SPCC.

La composizione del materiale di costruzione dei rivetti è conforme alle norme JIS G 3507, filetti metallici d'acciaio al carbonio SWRCH 12A.

## 2.2 MATERIAL OF THE CAGES AND THE RIVETS

*The composition of the material used to construct the cages conforms to JIS G 3141 norms; the cages are constructed with carbon rolled steel sheets, cooled and pressed SPCC. The composition of the material used to construct the rivets conforms to JIS G 3507 norms, metal threads of carbon steel SWRCH 12A.*

## 2.3 MATERIALE DEL CORPO

La composizione del materiale di costruzione delle fusioni dei supporti è HT 200 JIS G 5501 (ghisa) e le proprietà meccaniche sono illustrate nella tabella sotto riportata:

## 2.3 MATERIAL OF HOUSING

*The composition of the construction material used to fuse the housings is HT 200 JIS G 5501 (cast iron), the mechanical properties of which are illustrated in the table below:*

## Proprietà meccaniche delle fusioni in ghisa HT200

## Mechanical properties of cast iron HT 200

Classificazione Class	Spessore Thickness	Diametro della barra di prova Diameter of testing bar	Test di tensione Tension test	Test di frenatura laterale Traverse breaking test		Resistenza alla pressione Pressure strength	Test di durezza Hardness test
			Forza di tensione Tensile strenght	Forza di curvatura Bender strength	Deviazione Deflection		
			mm.	mm.	Kgf/mm <sup>2</sup>		
HT 200 JIS (FC 200)	< 06-08	13	< 32	53	1,8	75	187-255
	< 08-15	20	< 25	45	2,5	75	170-241
	< 15-30	30	< 20	40	2,5	75	170-241
	< 30-50	45	< 18	34	3,0	75	170-241
	< 50	60	< 16	31	4,5	75	160-229

## 2.4 MATERIALI DEGLI ALTRI COMPONENTI

Nella sotto indicata tabella vengono indicati quelli che sono i principali materiali utilizzati nella costruzione dei principali accessori relativi ai supporti.

## 2.4 MATERIAL OF OTHER COMPONENTS

The principle materials used to construct the main accessories relative to the housings are indicated in the table below.

Componenti Components	Materiale utilizzato Material used	Simboli JIS JIS symbols	Numeri JIS JIS numbers
Bussola Adapter sleeve	Acciaio al carbonio Carbon steel	S25C	JIS G 4051
Dado Nut	Acciaio al carbonio Carbon steel	S25C	JIS G 4051
Rosetta Washer	Lamine d'acciaio al carbonio rullate a freddo e pressate Cold roller carbon steel sheet and strip	SPCC	JIS G 3141
Anello di tenuta Shaft seal	Gomma nitrilica sintetica Synthetic nitrile rubber	-	-
Dispositivo di lubrificazione Slinger	Lamine d'acciaio al carbonio rullate a freddo e pressate Cold roller carbon steel sheet and strip	SPCC	JIS G 3141
Vite esagonale Hexagon set screw	Acciaio nichelato con cromo e molibdeno Nickel chromium molybdenum steel	SCM 435	JIS G 4105
Chiave esagonale Hexagon wrench key	Acciaio nichelato con cromo e molibdeno Nickel chromium molybdenum steel	SNCM 630	JIS G 4103
Ingrassatore Grease nipple	Ottone Brass	C 3604	JIS H 3250

## 2.5 TENUTE E PROTEZIONI

I cuscinetti utilizzati nei supporti **KDF®** prevedono un sistema di tenuta su entrambi i lati, costituito dalla combinazione di una tenuta in gomma sintetica fissata sull'anello esterno, rinforzata in acciaio e con relativo labbro; mentre sull'anello interno viene fissato uno schermo che ruota insieme all'anello interno stesso. Questo sistema di protezione previene la fuoriuscita di grasso e l'infiltrazione d'agenti inquinanti. Oltre a quanto sopra riportato e come accennato brevemente al punto 2, possono essere utilizzati ulteriori dispositivi di protezione, come i coperchi. L'utilizzo in sinergia di entrambi i dispositivi di protezione è particolarmente indicato in quei casi dove si è in presenza di agenti esterni particolarmente aggressivi, polvere, liquidi vari o quando l'impiego avviene in ambiente esterno.

## 2.5 SEALS AND COVERS

*The bearings used in **KDF®** housings provide a sealing system on both sides.*

*They are constructed with a seal which has synthetic rubber fixed to the external ring and is reinforced with the relative steel lip; while fixed on the inner ring there is a shield which turns together.*

*This protective system prevents grease from exiting and pollutants from entering.*

*In addition to what is reported above and as briefly mentioned in point n° 2., ulterior protection devices such as covers are available.*

*Both protection devices used at the same time is indicated in cases where the external agents are particularly aggressive such as dust, various liquids or for external use.*



## 3. TOLLERANZE E SIMBOLI

Le tolleranze dei cuscinetti e dei supporti sono state normalizzate a livello sia nazionale che internazionale in conformità alle norme JIS. I cuscinetti vengono in genere costruiti in classe di tolleranza standard

## 3. SYMBOLS AND TOLERANCES

*The tolerances of the bearings and their housings have been normalized at both national and international levels and conform to JIS norms. Generally, the bearings are constructed according to standard tolerances.*

<b>d</b>	diametro nominale del foro
$\Delta d_{mp}$	scostamento del diametro del foro dal valore nominale
<b>V<sub>dp</sub></b>	variazione del diametro del foro
<b>D</b>	diametro nominale esterno
$\Delta D_{mp}$	scostamento del diametro esterno medio dal valore nominale
<b>K<sub>ia</sub></b>	concentricità di rotazione dell'anello interno nel cuscinetto completo (precisione radiale di rotazione)
<b>K<sub>ea</sub></b>	concentricità di rotazione dell'anello esterno nel cuscinetto completo (precisione radiale di rotazione)
$\Delta B_s$	scostamento di una singola misura dell'altezza dell'anello interno rispetto alla dimensione nominale
$\Delta C_s$	scostamento di una singola misura dell'altezza dell'anello esterno rispetto alla dimensione nominale

<b>d</b>	<i>nominal bore diameter</i>
$\Delta d_{mp}$	<i>deviation of bore diameter from nominal value</i>
<b>V<sub>dp</sub></b>	<i>bore diameter variation</i>
<b>D</b>	<i>nominal outer diameter</i>
$\Delta D_{mp}$	<i>deviation of the mean outer diameter from nominal value</i>
<b>K<sub>ia</sub></b>	<i>concentricity radial run out of assembled bearing inner ring (run out radial precision)</i>
<b>K<sub>ea</sub></b>	<i>concentricity radial run out of assembled bearing outer ring (run out radial precision)</i>
$\Delta B_s$	<i>inner ring single height deviation as regards to nominal dimension</i>
$\Delta C_s$	<i>outer ring single height deviation as regards to nominal dimension</i>

## Anello interno - Inner ring

Dimensioni - Dimensions:  $\mu\text{m}/0,0001''$

Diametro interno (d) Inner diameter (d)				Tipo (cuscinetto con foro cilindrico) Type (cylindrical bore bearing) UC - HC - SA - SB - SER				Scostamento altezza Height deviation		Concentricità di rotazione Concentricity radial run out
Oltre Over		Fino a Up to		$\Delta d_{mp}$		$V_{dp}$	$\Delta B_s$	$\Delta C_s$	$K_{ia}$	
mm mm	pollici inch	mm mm	pollici inch	max	min	max	min	max	min	max
10		18		+15	0	10		0	-120	15
	0,3937		0,7087		+6	4		0	-47	6
18		30		+18	0	12		0	-120	18
	0,7087		1,1811		+7	5		0	-47	7
30		50		+21	0	14		0	-120	20
	1,1811		1,9685		+8	6		0	-47	8
50		80		+24	0	16		0	-150	25
	1,9685		3,1496		+9	6		0	-59	10
80		120		+28	0	19		0	-200	30
	3,1496		4,7244		+11	7		0	-79	12
120		180		+33	0	22		0	-250	35
	4,7244		7,0866		+13	9		0	-98	14

## Anello interno - Inner ring

Dimensioni - Dimensions:  $\mu\text{m}/0,0001''$

Diametro interno (d) Inner diameter (d)				Tipo (cuscinetto con foro cilindrico) Type (cylindrical bore bearing) CB				Scostamento altezza Height deviation		Concentricità di rotazione Concentricity radial run out
Oltre Over		Fino a Up to		$\Delta d_{mp}$		$V_{dp}$	$\Delta B_s$	$\Delta C_s$	$K_{ia}$	
mm mm	pollici inch	mm mm	pollici inch	max	min	max	min	max	min	max
10		18		0	-8	10		0	-120	15
	0,3937		0,7087		0	4		0	-47	6
18		30		0	-10	12		0	-120	18
	0,7087		1,1811		0	5		0	-47	7
30		50		0	-12	14		0	-120	20
	1,1811		1,9685		0	6		0	-47	8

## Anello esterno - Outer ring

Dimensioni - Dimensions:  $\mu\text{m}/0,0001''$

Diametro esterno (D) Outer diameter (D)				Scostamento del diametro esterno medio Deviation of the mean outer diameter				Concentricità di rotazione Concentricity radial run out
Oltre Over		Fino a Up to		$\Delta D_{mp}$				$K_{ea}$
mm mm	pollici inch	mm mm	pollici inch	max	min	max	min	max
18		30		0	-9			15
	0,7087		1,1811			0	-4	6
30		50		0	-11			20
	1,1811		1,9685			0	-4	8
50		80		0	-13			25
	1,9685		3,1496			0	-5	10
80		120		0	-15			35
	3,1496		4,7244			0	-6	14
120		150		0	-18			40
	4,7244		5,9055			0	-7	16
150		180		0	-25			45
	5,9055		7,0866			0	-10	18
180		250		0	-30			50
	7,0866		9,8425			0	-12	20
250		315		0	-35			60
	9,8425		12,4016			0	-14	24

Semiangolo del cono:  $\alpha$   
Half angle of cone:  $\alpha$

$$\alpha = 2^{\circ}23'9,4''$$

$$= 2.385\ 94^{\circ}$$

$$= 0.041\ 643\ \text{rad}$$

(conicità 1:12)  
(taper-ratio 1:12)

Diametro maggiore teorico  $d_1$ :  
Theoretical bigger diameter  $d_1$ :

$$d_1 = d + \frac{1}{12} B \quad (\text{conicità } 1:12)$$

$$\quad \quad \quad (\text{taper-ratio } 1:12)$$

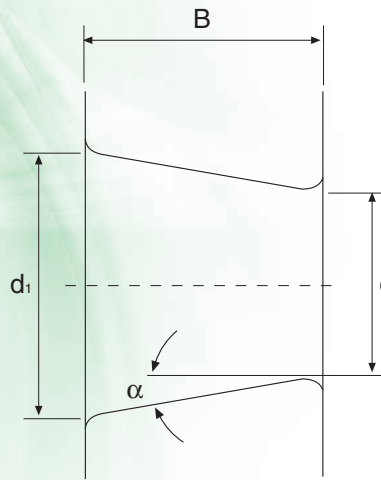

Foro conico teorico  
Theoretical bore diameter

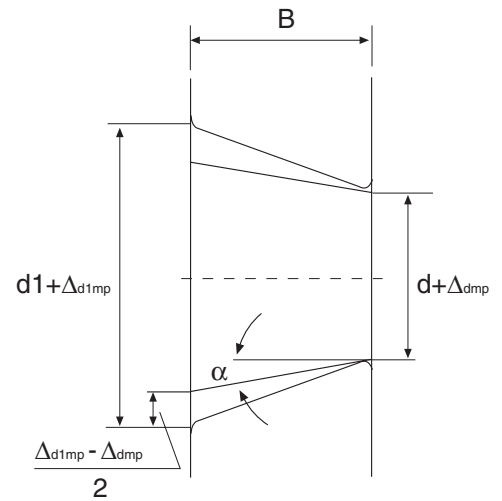

Foro conico con uno scostamento nella dimensione del diametro medio nella superficie piana  
Conical bore with deviation of mean diameter in flat surface

$\Delta d_{mp}$	Scostamento nella dimensione del diametro medio del foro nella superficie piana all'estremità minore teorica del foro conico
$\Delta d_{1mp}$	Scostamento nella dimensione del diametro medio del foro nella superficie piana all'estremità maggiore teorica del foro conico
$V_{dp}$	Variazione del diametro del foro
$V_{dp}$	Altezza dell'anello interno

$\Delta d_{mp}$	Deviation of mean bore diameter in a single plane (for a basically bore, $\Delta d_{mp}$ refers to the theoretical small end of the conical bore)
$\Delta d_{1mp}$	Deviation of mean bore diameter in a single plane at the theoretical large end of a basically conical bore)
$V_{dp}$	Bore diameter variation
$V_{dp}$	Inner ring height

Anello interno (foro conico) - Inner ring (conical bore)

Dimensioni - Dimensions:  $\mu\text{m}/0,0001''$

Diametro interno (d) Inner diameter (d)				$\Delta d_{mp}$				$\Delta d_{1mp} - \Delta d_{mp}$				$V_{dp}^1$
Oltre Over		Fino a Up to		max	min	max	min	max	min	max	min	max
mm mm	pollici inch	mm mm	pollici inch									
18		30		+21	0			+21	0			13
	0,7087		1,1811			+8	0			+8	0	5
30		50		+25	0			+25	0			15
	1,1811		1,9685			+10	0			+10	0	6
50		80		+30	0			+30	0			19
	1,9685		3,1496			+12	0			+12	0	7
80		120		+35	0			+35	0			25
	3,1496		4,7244			+14	0			+14	0	10
120		180		+40	0			+40	0			31
	4,7244		7,0866			+16	0			+16	0	12

<sup>1)</sup> Valido in ogni singolo piano radiale del foro - Valid for every radial flat of bore.

**Tolleranza della distanza (n) dalla linea centrale dell'anello esterno sferico all'anello interno**  
*Tolerance in distance (n) from centre line of spherical outer ring to side of inner ring*

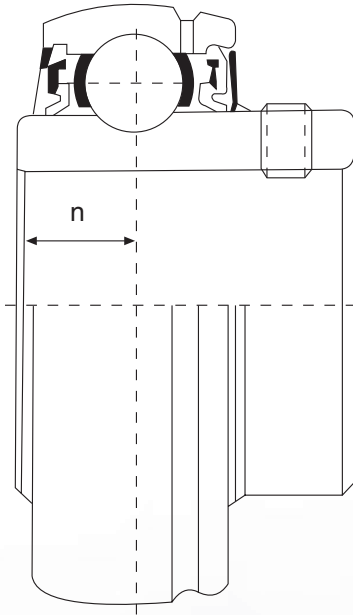

**Dimensioni - Dimensions:  $\mu\text{m}/0,0001''$**

Diametro interno (d) Inner diameter (d)				Tolleranza (n) Tolerance (n)
Oltre Over		Fino a Up to		
mm mm	pollici inch	mm mm	pollici inch	
2,5		50		$\pm 200$
	0,0984		1,9685	$\pm 79$
50		80		$\pm 250$
	1,9685		3,1496	$\pm 98$
80		120		$\pm 300$
	3,1496		4,7244	$\pm 118$
120		-		$\pm 350$
	4,7244		-	$\pm 138$

### 3.1 TOLLERANZE DEI SUPPORTI

### 3.1 BEARING UNITS TOLERANCES

Diametro del foro sferico del supporto  
*Spherical bore diameter of bearing units*

**Dimensioni - Dimensions:  $\mu\text{m}/0,0001''$**

Diametro del foro sferico (D <sub>a</sub> ) Spherical bore diameter (D <sub>a</sub> )				Scostamento del diametro medio del foro ( $\Delta D_{am}$ ) Mean bore diameter deviation ( $\Delta D_{am}$ )											
Oltre Over		Fino a Up to		Tolleranza H7 H7 tolerance				Tolleranza J7 J7 tolerance				Tolleranza K K tolerance			
mm mm	pollici inch	mm mm	pollici inch	min	max	min	max	min	max	min	max	min	max	min	max
30		50		+25	0			+14	-11			+7	-18		
	1,1811		1,9685			+10	0			+6	-4			+3	-7
50		80		+30	0			+18	-12			+9	-21		
	1,9685		3,1496			+12	0			+7	-5			+4	-8
80		120		+35	0			+22	-13			+10	-25		
	3,1496		4,7244			+14	0			+9	-5			+4	-10
120		180		+40	0			+26	-14			+12	-28		
	4,7244		7,0866			+16	0			+10	-6			+5	-11
180		250		+46	0			+30	-16			+13	-33		
	7,0866		9,8425			+18	0			+12	-6			+5	-13
250		315		+52	0			+36	-16			-	-		
	9,8425		12,4016			+20	0			+14	-6			-	-

Dimensioni - *Dimensions*:  $\mu\text{m}/0,0001''$

Tipologia dei supporti ritri <i>Pillow block units type</i>						Scostamento H <i>Deviation H</i>
P203	-	-	-	-	-	±150 ±59
P204	-	-	HP204	UP204	PL204	
P205	P305	PX05	HP205	UP205	PL205	
P206	P306	PX06	HP206	UP206	PL206	
P207	P307	PX07	HP207	UP207	PL207	
P208	P308	PX08	HP208	UP208	-	
P209	P309	PX09	HP209	UP209	PL209	
P210	P310	PX10	HP210	UP210	PL210	
P211	P311	PX11	-	-	-	
P212	P312	PX12	-	-	-	±200 ±79
P213	P313	PX13	-	-	-	
P214	P314	PX14	-	-	-	
P215	P315	PX15	-	-	-	
P216	P316	PX16	-	-	-	
P217	P317	PX17	-	-	-	
P218	P318	PX18	-	-	-	
-	P319	-	-	-	-	±300 ±118
-	P320	PX20	-	-	-	
-	P321	-	-	-	-	
-	P322	-	-	-	-	
-	P324	-	-	-	-	
-	P326	-	-	-	-	
-	P328	-	-	-	-	

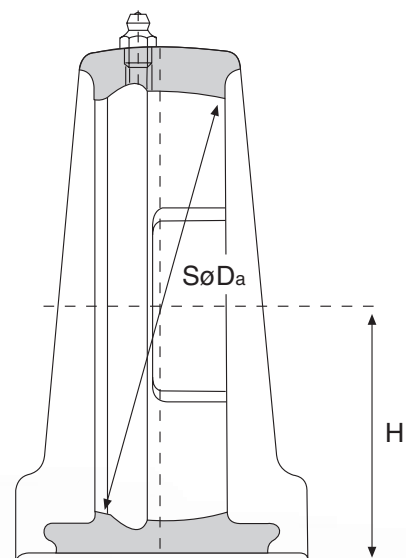



## 3.3 TOLLERANZE DEI SUPPORTI FLANGIATI

## 3.3 FLANGE BEARING UNITS TOLERANCES

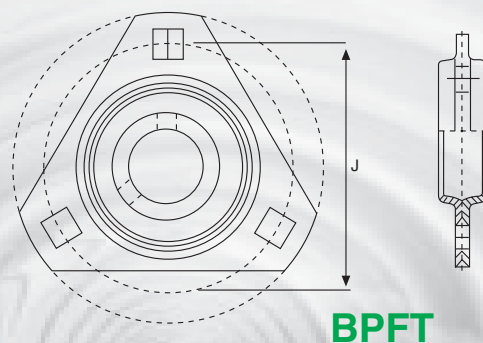
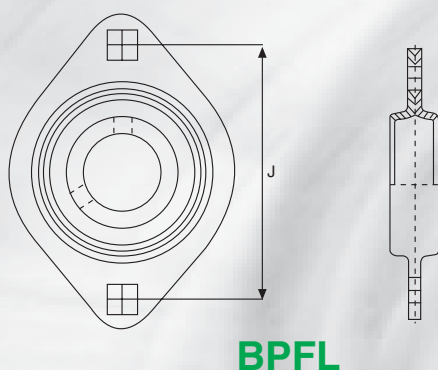
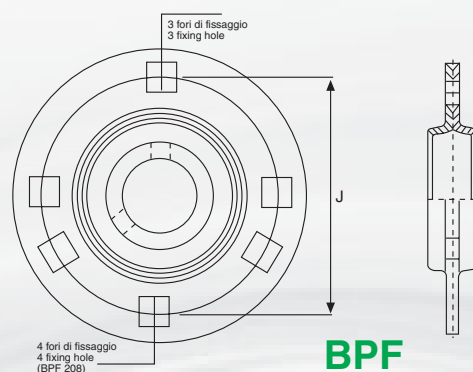
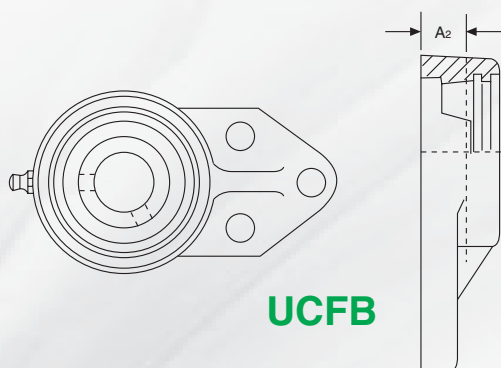
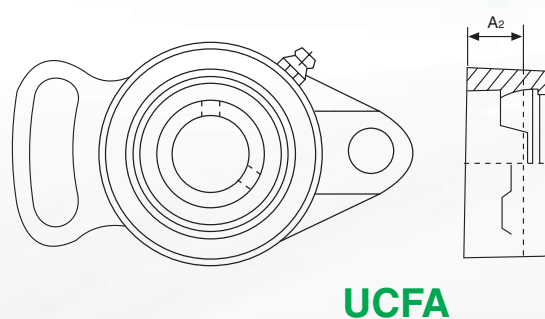
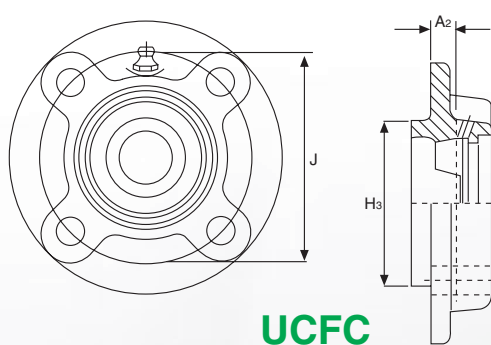
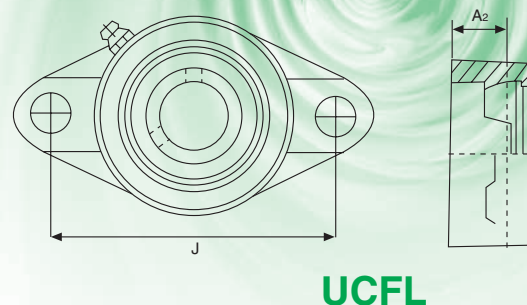
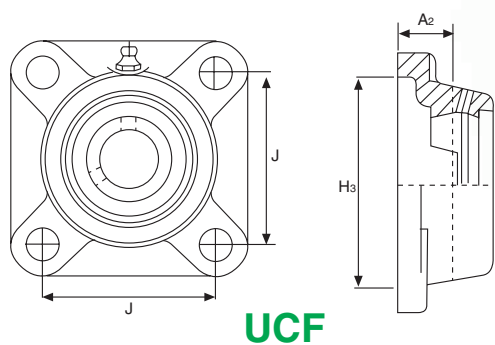

Tipologia dei supporti flangiati Flange bearing units type							Tolleranza J Tolerance	Tolleranza A <sub>2</sub> Tolerance	Spostamenti H <sub>3</sub> H <sub>3</sub> deviation						Difetto radiale Y Spigot run-out				
									FC2		FCX		FS3			max.			
									max. min.	max. min.	max. min.	max. min.	max. min.	max. min.					
F2...	F3...	FX...	FC2...	FS3...	FL2...	FL3...	±700 ±276	±500 ±197	0	0	-	-	-	-	200 79				
F204	-	-	FC204	-	FL204	-			0	0	-	-	-	-		-	-		
F205	F305	FX05	FC205	FS305	FL205	FL305			-46	-18	0	-46	0	-18		0	-46	0	-18
F206	F306	FX06	FC206	FS306	FL206	FL306			0	0	0	0	0	0		0	0	0	
F207	F307	FX07	FC207	FS307	FL207	FL307			0	0	0	0	0	0		0	0	0	
F208	F308	FX08	FC208	FS308	FL208	FL308			0	0	-54	0	-54	0		-21	0	-21	
F209	F309	FX09	FC209	FS309	FL209	FL309			-54	-21	-54	-21	-54	-21	-54	-21	-54	-21	
F210	F310	FX10	FC210	FS310	FL210	FL310			0	0	0	0	0	0	0	0	0		
F211	F311	FX11	FC211	FS311	FL211	FL311			0	0	0	0	0	0	0	0	0		
F212	F312	FX12	FC212	FS312	FL212	FL312			0	0	0	0	0	0	0	0	0		
F213	F313	FX13	FC213	FS313	FL213	FL313			0	0	-63	0	-63	0	-25	0	-25		
F214	F314	FX14	FC214	FS314	FL214	FL314			-63	-25	-63	-25	-63	-25	-63	-25	-63	-25	
F215	F315	FX15	FC215	FS315	FL215	FL315			0	0	0	0	0	0	0	0	0		
F216	F316	FX16	FC216	FS316	FL216	FL316			0	0	0	0	0	0	0	0	0		
F217	F317	FX17	FC217	FS317	FL217	FL317			0	0	0	0	0	0	0	0	0		
F218	F318	FX18	FC218	FS318	FL218	FL318			0	0	0	0	0	0	0	0	0		
-	F319	-	-	FS319	-	FL319			±1000 ±394	±800 ±315	-	-	-	-	-	-	-	300 118	
-	F320	FX20	-	FS320	-	FL320			0	0	0	0	0	0	0	0	0		
-	F321	-	-	FS321	-	FL321	0	0	0	0	0	0	0	0	0				
-	F322	-	-	FS322	-	FL322	-	-	-	-	-	-	-	-	-				
-	F324	-	-	FS324	-	FL324	-	-	-	-	-	-	-	-	-				
-	F326	-	-	FS326	-	FL326	-	-	-	-	-	-	-	-	-				
-	F328	-	-	FS328	-	FL328	-	-	-	-	-	-	-	-	-				
-	-	-	-	-	-	-	-	-	-	-	-	-	-	-	-	400			
-	-	-	-	-	-	-	-	-	-	-	-	-	-	-	-	157			

### 3.4 TOLLERANZE DEI SUPPORTI SCORREVOLI ED A CARTUCCIA

### 3.4 TAKE-UP AND CYLINDRICAL CARTRIDGE BEARING UNITS TOLERANCES

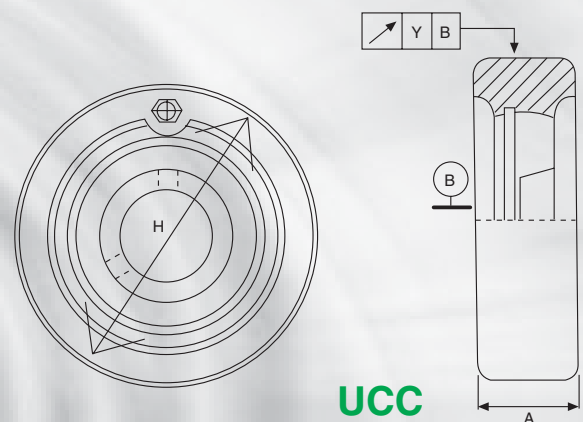
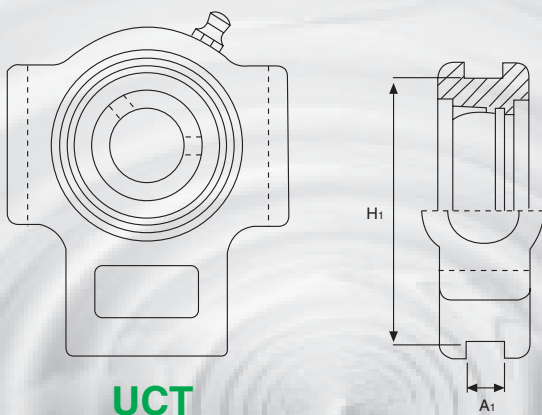

## Dimensioni - Dimensions: $\mu\text{m}/0,0001''$

Tipologia dei supporti scorrevoli Take-up bearing units type			Tolleranza A <sub>1</sub> Tolerance		Tolleranza H <sub>1</sub> Tolerance		Parallelismo di guida Parallelism of sliding bolt	Tipologia dei supporti a cartuccia Cylindrical cartridge bearing units type			Tolleranza H H Tolerance						Difetto radiale Y Spigot run-out	Scostamento A Deviation				
			C2...		CX...						C3...											
			max. min.	max. min.	max. min.	max. min.					max. min.	max. min.	max. min.	max. min.	max.							
T2...	TX...	T3...	+200 0	+79 0	0	-500	500	C2...	CX...	C3...	0	0	-	-	-	-	200	±200				
T204	-	T304						C204	CX204	C304	0	0	-	-	-	-			-	-	-	
T205	TX205	T305						C205	CX205	C305	-30	-12	-	-	-	-			-	-	-	
T206	TX206	T306						C206	CX206	C306	0	0	0	0	0	0			0	0	0	
T207	TX207	T307						C207	CX207	C307	0	0	-35	-14	-35	-14			-35	-14	-35	-14
T208	TX208	T308						C208	CX208	C308	0	0	-	-	-	-			-	-	-	-
T209	TX209	T309						C209	CX209	C309	-35	-14	-	-	-	-			-	-	-	-
T210	TX210	T310						C210	CX210	C310	0	0	-	-	-	-			-	-	-	-
T211	TX211	T311						C211	CX211	C311	0	0	-40	-16	0	0			-40	-16	0	0
T212	TX212	T312						C212	CX212	C312	-40	-16	-	-	-	-			-	-	-	-
T213	TX213	T313	-	-	C313	-	-	-	-	-	-	-	-	-	-	-						
T214	TX214	T314	-	-	C314	-	-	-	-	-	-	-	-	-	-	-	-					
T215	TX215	T315	-	-	C315	-	-	-	-	-	-	-	-	-	-	-	-					
T216	TX216	T316	+300	+118	0	-800	600	-	-	-	-	-	-	-	-	0	0					
T217	TX217	T317	0	0	0	-315	236	-	-	-	-	-	-	-	-	-46	-18					
-	-	T318	-	-	-	-	-	-	-	-	-	-	-	-	-	-	-					
-	-	T319	-	-	-	-	-	-	-	-	-	-	-	-	-	-	-					
-	-	T320	-	-	-	-	700	-	-	-	-	-	-	-	-	-	-					
-	-	T321	-	-	-	-	276	-	-	-	-	-	-	-	-	0	0					
-	-	T322	-	-	-	-	-	-	-	-	-	-	-	-	-	-52	-20					
-	-	T324	-	-	-	-	-	-	-	-	-	-	-	-	-	-	-					
-	-	T326	-	-	-	-	800	-	-	-	-	-	-	-	-	0	0					
-	-	T328	-	-	-	-	315	-	-	-	-	-	-	-	-	-57	-22					

### 3.5 TOLLERANZE DEGLI ALBERI

Le tolleranze degli alberi, sono influenzate e determinate principalmente da due fattori; il diametro ed il numero dei giri che devono compiere. Nel caso l'albero preveda un impiego con un numero di giri basso, si possono utilizzare tolleranze h 9, mentre nei casi in cui gli alberi devono compiere molti giri è preferibile utilizzare tolleranze più ristrette.

### 3.5 SHAFTS TOLERANCES

The tolerances of the shafts are influenced and determined mainly by two factors: the diameter and the number of rounds to be completed. Should the shaft require a low number of rounds, the tolerance can be h9, whereas, if the shaft requires a higher number of rounds it is preferable to use a more narrow tolerance.

Tolleranze albero per cuscinetti serie **UC - SB - SA**  
Shaft tolerance for **UC - SB - SA** bearings series

## Dimensioni - Dimensions: $\mu\text{m}/0,0001''$

Dimensione dell'albero (d) Shaft dimension (d)				Tolleranza diametro dell'albero Diameter shaft tolerance			
Oltre - Over		Fino a - Up to		j6	h6	h7	h8
mm	pollici	mm	pollici	dn > 120 000	dn ≤ 120 000	dn ≤ 100 000	dn ≤ 60 000
10	0,3937	18	0,7087	+8 ~ -3	0 ~ -11	0 ~ -18	0 ~ -27
				+3 ~ -1	0 ~ -4	0 ~ -7	0 ~ -11
18	0,7087	30	1,1811	+9 ~ -4	0 ~ -13	0 ~ -21	0 ~ -33
				+4 ~ -2	0 ~ -5	0 ~ -8	0 ~ -13
30	1,1811	50	1,9685	+11 ~ -5	0 ~ -16	0 ~ -25	0 ~ -39
				+4 ~ -2	0 ~ -6	0 ~ -10	0 ~ -15
50	1,9685	80	3,1496	+12 ~ -7	0 ~ -19	0 ~ -30	0 ~ -46
				+5 ~ -3	0 ~ -7	0 ~ -12	0 ~ -18
80	3,1496	120	4,7244	+13 ~ -9	0 ~ -22	0 ~ -35	0 ~ -54
				+5 ~ -4	0 ~ -9	0 ~ -14	0 ~ -21
120	4,7244	180	7,0866	+14 ~ -11	0 ~ -25	0 ~ -40	0 ~ -63
				+6 ~ -4	0 ~ -10	0 ~ -16	0 ~ -25

Tolleranze albero per cuscinetti serie **UK**  
*Shaft tolerance for UK bearings series*

Dimensioni - *Dimensions*: μm/0,0001”

Dimensioni dell'albero (d) <i>Shaft dimensions (d)</i>				Tolleranze diametro dell'albero <i>Diameter shaft tolerances</i>							
Oltre - <i>Over</i>		Fino a - <i>Up to</i>		h8		h9		h10		h11	
mm <i>mm</i>	pollici <i>inch</i>	mm <i>mm</i>	pollici <i>inch</i>	Superiore Upper	Inferiore Lower	Superiore Upper	Inferiore Lower	Superiore Upper	Inferiore Lower	Superiore Upper	Inferiore Lower
10	0,3937	18	0,7087	0 - 27	0 - 11	- -	- -	- -	- -	- -	- -
18	0,7087	30	1,1811	0 - 33	0 - 13	0 - 52	0 - 20	0 - 84	0 - 33	0 - 120	0 - 47
30	1,1811	50	1,9685	0 - 39	0 - 15	0 - 62	0 - 24	0 - 100	0 - 39	0 - 160	0 - 63
50	1,9685	80	3,1496	0 - 46	0 - 18	0 - 74	0 - 29	0 - 120	0 - 47	0 - 190	0 - 75
80	3,1496	120	4,7244	0 - 54	0 - 21	0 - 87	0 - 34	0 - 140	0 - 55	0 - 200	0 - 79
120	4,7244	180	7,0866	0 - 63	0 - 25	0 - 100	0 - 39	0 - 160	0 - 63	0 - 250	0 - 98

### 3.6 PRECISIONE DIMENSIONALE DELLE FUSIONI

Per conoscere il grado di precisione dimensionale delle fusioni, quando questo valore non è specificato, sarà opportuno far riferimento allo standard **JIS B 0405** (valore che rappresenta lo scostamento medio dimensionale ammissibile, in assenza di valori indicati).

### 3.6 DIMENSIONAL ACCURACIES OF CASTINGS

*When the dimensional accuracy of the casting is not specified simply refer to the JIS B 0405 standard (the average deviation admissible in absence of indicated values).*

Dimensioni - *Dimensions*: μm/0,0001”

Dimensioni <i>Dimensions</i>				Tolleranza dimensionale della classe media <i>Middle class dimensional tolerance</i>	
Superiore - <i>Upper</i>		Incluso - <i>Included</i>			
mm <i>mm</i>	pollici <i>inch</i>	mm <i>mm</i>	pollici <i>inch</i>		
0,5	0,0197	6	0,2362	±100	±39
6	0,2362	30	1,1811	±200	±79
30	1,1811	120	4,7244	±300	±118
120	4,7244	315	12,4016	±500	±197
315	12,4016	1000	39,3701	±800	±315

### 3.7 TOLLERANZE DELLE FUSIONI

La precisione dimensionale della fusione segue lo standard **JIS B 0407** (scostamento medio delle dimensioni in assenza d'indicazione sulla tolleranza della fusione).

### 3.7 CASTINGS TOLERANCES

*The dimensional accuracy of the castings is done according to JIS B 0407 (average deviation of the dimensions when the tolerance is absent from the casting).*

Tolleranza nella lunghezza - Tolerance in length				Tolleranza nello spessore - Tolerance in thickness					
Dimensioni - Dimensions				Dimensioni - Dimensions					
Superiore - Over		Incluso - Included		Tolleranza Tolerance	Superiore - Over		Incluso - Included		Tolleranza Tolerance
mm	pollici	mm	pollici		mm	pollici	mm	pollici	
-	-	120	4,7244	$\pm 1\,500$	-	-	-	-	-
120	4,7244	250	9,8425	$\pm 2\,000$	-	-	10	0,3937	$\pm 1\,500$
250	9,8425	400	15,7480	$\pm 3\,000$	10	0,3937	18	0,7087	$\pm 2\,000$
400	15,7480	800	31,4961	$\pm 4\,000$	18	0,7087	30	1,1811	$\pm 3\,000$
800	31,4961	1\,600	62,9921	$\pm 6\,000$	30	1,1811	50	1,9685	$\pm 3\,500$
				$\pm 2\,362$					$\pm 1\,378$

### 3.8 CARICO AMMISSIBILE DEI SUPPORTI

La capacità di carico dei supporti, è determinata principalmente da due fattori:

- la forma
- la direzione del carico.

Visto che ogni supporto ha caratteristiche diverse nella forma, può risultare difficile calcolare le capacità di carico permesse.

In tutti i casi è sempre opportuno prestare attenzione sulla direzione della forza applicata, che può essere verso il basso, verso l'alto, orizzontale o assiale.

### 3.8 ALLOWED LOAD OF HOUSINGS

The housing load is determined principally by two factors:

- the form
- the direction of the load

As each housing has different characteristics in different forms, it can be difficult to calculate the permitted load capacity.

In any case, it is always helpful to consider the direction of the force applied. The direction can be upward, downward, horizontal or axial.

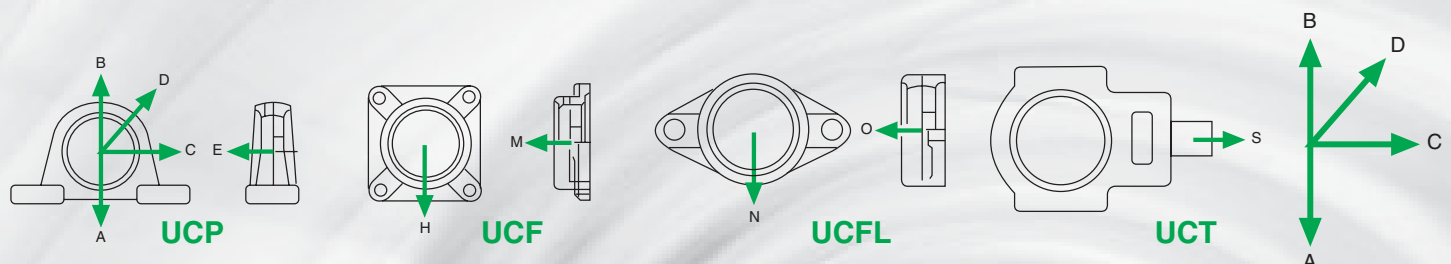

A/H/N Direzione verso il basso  
 B Direzione verso l'alto  
 C/S Direzione in orizzontale  
 D Direzione a 45°  
 E/M/O Direzione assiale

A/H/N Downward direction  
 B Upward direction  
 C/S Horizontal direction  
 D 45° direction  
 E/M/O Axial direction

Dimensioni Dimensions	Carico statico di rottura - Static ratings load									
	Tipo - Type					Tipo - Type		Tipo - Type		Tipo - Type
	UCP					UCF		UCFL		UCT
	A	B	C	D	E	H	M	N	O	S
203	69	29	49	22	10	-	-	-	-	-
204	79	32	54	24	16	42	17	23	11	33
205	92	36	59	27	17	65	24	37	15	37
206	117	49	88	34	21	65	29	37	19	40
207	156	59	98	43	23	63	35	40	22	56
208	176	64	107	45	24	69	38	40	26	80
209	186	68	117	48	25	98	46	60	31	76
210	186	73	137	55	31	98	49	60	38	84
211	205	80	147	58	33	90	55	72	43	95
212	274	107	166	71	43	90	60	86	47	98
213	284	117	186	81	49	166	67	96	60	127
214	313	117	196	82	54	186	74	98	68	127
215	323	127	205	90	56	186	78	107	70	127
216	352	147	264	107	64	166	84	127	84	137
217	441	166	274	117	73	205	93	137	92	156
218	470	186	323	127	117	245	107	137	137	-

### 3.9 CARICO AMMISSIBILE DEI SUPPORTI IN LAMIERA STAMPATA

I supporti in lamiera stampata **KDF®** quando vengono sottoposti a dei carichi potrebbero presentare delle deformazioni. Tali deformazioni possono variare a seconda della direzione che dall'ammontare del carico stesso, inoltre anche la forma del supporto e lo spessore dei lamierini possono influire sull'entità delle deformazioni. Da quanto sopra esposto si deduce che il carico ammissibile deve essere tale che la deformazione provocata, non pregiudichi la funzionalità del supporto stesso. Il carico ammesso sarà approssimativamente 1/3 del valore di carico base in direzione radiale ed 1/3 del carico radiale permesso in direzione assiale.

### 3.9 ALLOWED LOAD OF PRESSED HOUSINGS

*When the housings in sheets stamped **KDF®** are subjected to loads, deformations could present themselves. Such deformations may vary according to the direction of the total load itself, furthermore, also the form of the housing or the thickness of the sheet can influence the entity of the deformations. From all of the above we can deduct that the allowable load should be such that the deformation provoked does not prejudice the functionality of the housing itself. The allowable load will be approximately 1/3 of the base load value in a radial direction and 1/3 of the radial load permitted in axial direction*

### 3.10 COEFFICIENTI DI SICUREZZA

Prima dell'impiego di un supporto è necessario determinare l'intensità e la direzione del carico tenendo conto dei relativi fattori di sicurezza. Per stabilire il carico ammissibile bisogna dividere il valore del carico statico di rottura per il fattore di sicurezza.

### 3.10 SAFETY FACTOR

*Before using a housing unit it is necessary to determine the intensity and direction of the load considering the pertinent factor of security. To establish the admissible load it is necessary to divide the value of static load by the security factor.*

Condizioni di carico <i>Load conditions</i>	Carico permanente <i>Permanent load</i>	Carico vibratorio <i>Vibratory load</i>	Carico improvviso <i>Unexpected load</i>
Coefficiente di sicurezza <i>Safety factor</i>	4	10	15

### 3.11 VELOCITÀ MASSIMA (GIRI AL MINUTO)

Tipo <i>Type</i>	Diametro <i>Diameter</i>	Tolleranza max. ammissibile n. giri <i>Max rpm.</i>			
		j7	h7	h8	h9
UC-SB	mm				
201	12	6 700	5 900	4 300	1 600
202	15	6 700	5 500	4 000	1 500
203	17	6 700	5 300	3 800	1 400
204	20	6 700	4 900	3 500	1 250
205	25	5 600	4 100	2 900	1 050
206	30	4 700	3 400	2 400	880
207	35	4 000	3 000	2 100	760
208	40	3 600	2 600	1 900	680
209	45	3 300	2 400	1 700	620
210	50	3 000	2 200	1 600	570
211	55	2 700	2 000	1 400	510
212	60	2 400	1 800	1 250	460
213	65	2 300	1 700	1 150	420
214	70	2 200	1 600	1 100	400
215	75	2 000	1 500	1 000	380
216	80	1 900	1 400	960	350
217	85	1 800	1 300	900	330
218	90	1 700	1 200	840	310
-	-	-	-	-	-
-	-	-	-	-	-
-	-	-	-	-	-

### 3.11 MAX RPM.

Tipo <i>Type</i>	Diametro <i>Diameter</i>	Tolleranza max. ammissibile n. giri <i>Max rpm.</i>			
		j7	h7	h8	h9
UC	mm				
305	25	5 000	3 700	2 600	940
306	30	4 300	3 100	2 200	800
307	35	3 800	2 800	2 000	720
308	40	3 400	2 500	1 700	640
309	45	3 000	2 200	1 500	560
310	50	2 700	2 000	1 400	500
311	55	2 500	1 800	1 300	470
312	60	2 300	1 700	1 150	430
313	65	2 100	1 500	1 100	400
314	70	2 000	1 400	1 000	370
315	75	1 800	1 300	930	340
316	80	1 700	1 250	870	320
317	85	1 600	1 150	810	300
318	90	1 500	1 100	760	280
319	95	1 400	1 000	720	260
320	100	1 300	940	660	240
321	105	1 250	900	630	230
322	110	1 200	830	590	210
324	120	1 100	750	530	190
326	130	1 000	680	480	180
328	140	900	620	440	160



## 4. COEFFICIENTI DI CARICO E DURATA

La durata dei cuscinetti volventi può essere definita come il numero di giri o di ore di funzionamento, che il cuscinetto è in grado di sopportare prima che compaiano i primi segni di fatica su uno degli anelli, sulla pista di rotolamento o sugli elementi volventi. Tali segnali d'affaticamento sono causati da ripetute sollecitazioni, che influenzano i materiali di composizione dei cuscinetti. Vi sono comunque altri fattori che possono influenzare la durata della vita di un cuscinetto, ad esempio, l'abrasione, la corrosione, il grippaggio, l'ossidazione, la ruggine.

## 4. LOAD RATINGS AND LIFE

*The life of rotating bearings can be defined as the number of rounds or by the functioning hours, that the bearing is capable of withstanding before showing the first signs of wear on one of the rings, on the rotating track or on the rotating elements. Such signs of wear are caused by repeated use and are influenced by the composition materials of the bearings.*

*There are in any case other factors that can influence the life of a bearing; for example, abrasion, corrosion, the binding, oxidation and rust.*

Questi tipi di problemi possono presentarsi per eventuali applicazioni non idonee, per un errato montaggio, per insufficiente o non avvenuta lubrificazione. I problemi sopra elencati, sono da considerarsi diversi dal cedimento dei materiali, in quanto potrebbero essere evitati con le dovute precauzioni. Ove si voglia tenere in considerazione solamente la fatica nelle superfici di lavoro del cuscinetto, si dovranno osservare le seguenti condizioni:

1. le forze e le velocità tenute in considerazione per la valutazione del cuscinetto dovranno corrispondere a quelle riportate alle reali condizioni d'esercizio.
2. durante l'intero periodo d'esercizio dovrà essere assicurata un'adeguata lubrificazione.
3. l'esperienza dimostra come il cedimento di molti cuscinetti sia da attribuirsi a cause diverse dalla fatica, quali: scelta di un cuscinetto di tipo inadeguato, difetti di funzionamento o di lubrificazione, presenza di particelle estranee nel cuscinetto, od altro.

La durata a fatica nominale di un singolo cuscinetto, o di una campionatura di cuscinetti identici e operanti a identiche condizioni di esercizio, consiste nella durata d'esercizio pari almeno ad un grado di affidabilità del 90%.

La durata media di un gruppo di cuscinetti è di molto superiore alla durata nominale.

La durata a fatica nominale è espressa con L10 (milioni di giri - coefficiente di carico dinamico) o L10h (ore d'esercizio).

La sotto indicata equazione, permette di calcolare la relazione tra la durata nominale, il coefficiente di carico dinamico ed il carico agente sul cuscinetto:

$$L_{10} = \left( \frac{C}{P} \right)^p$$

dove;

**L<sub>10</sub>** durata nominale espressa 10<sup>6</sup> di giri  
**C** coefficiente di carico dinamico del cuscinetto, espresso in N  
**P** carico dinamico equivalente sul cuscinetto, espresso in N  
**p** esponente di durata dell'equazione, con i seguenti valori:

**P=** 3 per i cuscinetti a sfere

**p=** 10/3 per i cuscinetti a rulli

*These types of problems can present themselves due to eventual applications which are not fit or due to mounting errors or for insufficient or lack of lubrication. The above mentioned problems should be considered differently from problems with materials that yield because they can be avoided by the necessary precautions. Where one considers only the wear and tear on the working surface of the bearing, the following conditions should be observed:*

- 1. the force and speed of the bearing as explained should correspond to the real conditions of the exercise in order to evaluate the bearing.*
- 2. during the entire exercise period the adequate lubrication should be assured.*
- 3. experience has shown us that the yielding of many bearings can be attributed to causes other than wear and tear, such as: the choice of an adequate bearing, functional or lubrication defects, the presence of foreign particles in the bearing and other things.*

*The life at nominal wear of a single bearing or of a sampling of identical bearings and operating under identical conditions of exercise, consists in the length of the exercise equal to at least a 90% level of reliability. The average life of a group of bearings is well above the nominal life. The life at nominal wear and tear is expressed as L10 (millions of rounds - the coefficient of a dynamic load) or L10h (hours of exercise). The equation illustrated below calculates the relation between the nominal life and the coefficient of the dynamic load and the agent load on the bearing:*

where;

**L<sub>10</sub>** the nominal life expresses 10<sup>6</sup> rounds  
**C** the coefficient of the dynamic load of the bearing, expressed in N  
**P** the dynamic load equivalent on the bearing, expressed in N  
**p** the exponent of the length of the equation with the following values:

**P=** 3 for spherical bearings

**p=** 10/3 for roller bearings



Per cuscinetti utilizzati a velocità costante, la durata a fatica nominale, espressa in ore di funzionamento, potrà essere calcolata con la presente equazione:

*For bearings used at constant speeds, the life at nominal wear and tear, expressed in functioning hours, can be calculated with the present equation:*

$$L_{10h} = \left( \frac{10^6}{n \cdot 60} \right) \left( \frac{C}{P} \right)^p$$

dove;

*where;*

**n** velocità di rotazione, espressa in giri/minuti

*n* the speed of rotation, expressed in rounds per minutes

Nella determinazione delle dimensioni del cuscinetto è necessario basare i calcoli sulla durata a fatica nominale corrispondente all'effettivo impiego. Di solito questo dipende dal tipo di macchina, dalla durata richiesta e dai requisiti inerenti la sicurezza di funzionamento.

*In the determination of the dimensions of the bearing it is necessary to base the calculations on the life at nominal wear and tear corresponding to the effective use. Usually this depends on the type of machine, the life requested and on the inherent functioning safety.*

Le relazioni tra il regime di rotazione ed il fattore di velocità così come tra la durata nominale ed il fattore di durata sono esplicitati nella sotto riportata tabella.

*The relation between the rotation regime and the speed factor as well as the relation between the nominal life and the life factor are explained in the table below.*

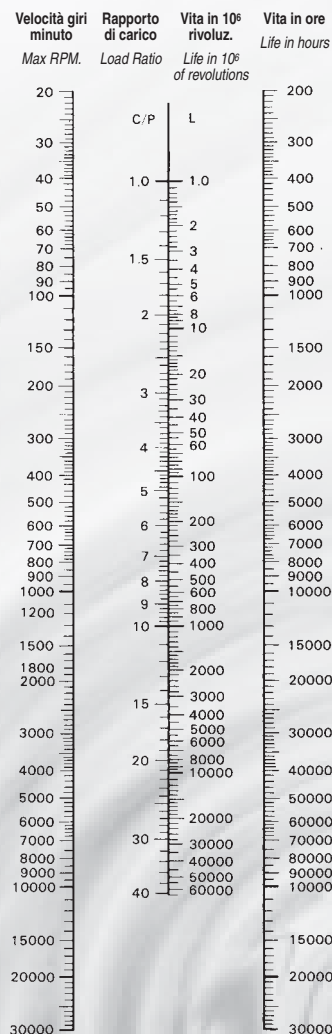

## 4.1 COEFFICIENTE DI CARICO STATICO $C_0$

Il coefficiente di carico statico  $C_0$  può essere considerato quando il cuscinetto è stazionario o sottoposto a rotazioni e/o oscillazioni particolarmente lente (inferiori a 10 giri max. per minuto), pertanto il coefficiente di carico statico non verrà determinato in funzione della fatica del materiale, ma in base alla deformazione permanente indotta in corrispondenza del punto di contatto tra la superficie volvente e la pista di rotolamento.

Per i cuscinetti radiali, il carico è espresso in direzione radiale, ed il punto di pressione tra i corpi volventi e le piste di rotolamento possono raggiungere i seguenti valori:

4 200 N/mm<sup>2</sup> per i cuscinetti a sfere

Nelle condizioni sopra indicate, il coefficiente di carico statico  $C_0$ , corrisponde approssimativamente alla deformazione dell'elemento volvente più caricato ed alla deformazione di una delle piste di rotolamento uguale a 1/10 000 del diametro del corpo volvente. Quanto sopra espresso è da considerarsi valido in condizioni normali d'impiego e la deformazione può essere tollerata, senza che l'efficienza di funzionamento sia pregiudicata.

## 4.2 COEFFICIENTE DI SICUREZZA STATICO $S_0$

Per quanto sopra esposto, la capacità di carico statica, determina il valore che un cuscinetto è in grado di sopportare se sottoposto a carichi, ma in assenza o ridotta presenza di movimento. Questi carichi possono comunque creare delle deformazioni, a volte permanenti, per questo motivo è importante considerare il concetto di coefficiente di sicurezza del cuscinetto contro eventuali deformazioni. Il coefficiente di sicurezza statico, può essere determinato attraverso la seguente formula:

$$S_0 = \frac{C_0}{P_0}$$

considerando che:

- $S_0$  - fattore di sicurezza statico
- $C_0$  - coefficiente di carico statico (Kg., N)
- $P_0$  - carico massimo ammissibile (Kg., N)

## 4.1 STATIC LOAD RATINGS $C_0$

*The static load coefficient  $C_0$  can be considered when the bearing is stationary or subject to rotation and or particularly slow oscillation (below 10 rounds max. per minute), therefore the coefficient of the static load will not be determined in function of the wear on the material, but based on the permanent deformation induced at the point of contact between the rotating surface and the rolling track. As for radial bearings, the load is expressed in radial direction and the pressure point between the rotating bodies and the rolling track can reach the following values:*

*4 200 N/mm<sup>2</sup> per spherical bearings*

*In conditions indicated above, the coefficient of the static load  $C_0$ , corresponds approximately to the deformation of the rotating element plus the load and to the deformation of one of the rolling tracks equal to 1/10 000 of the diameter of the rotating body. All of the above can be considered valid in normal conditions of use and the deformation can be tolerated, without prejudicing the functioning efficiency.*

## 4.2 STATIC LOAD SAFETY FACTOR $S_0$

*For all of the above, the static load capacity, determines the value that a bearing is capable of supporting if subjected to loads, but in absence or in the reduced presence of movement. These loads can anyway create deformations, sometimes permanent, for this reason it is important to consider the concept of the safety factor of the bearing against eventual deformation. The static safety factor can be determined using the following formula:*

*consider that:*

- $S_0$  - static safety factor
- $C_0$  - static load coefficient (Kg.,N)
- $P_0$  - maximum load allowable (Kg.,N)

Valori indicativi del coefficiente di sicurezza statico  $S_0$   
 $S_0$  static safety load rating coefficient

Condizioni operative <i>Working conditions</i>	Cuscinetti a sfere <i>Roller bearings</i>
<b>Elevata precisione di rotazione, con carichi ed urti</b> <i>High rotation precision, with heavy loads and impact</i>	2
<b>Precisione normale di rotazione, con maggiori esigenze di silenziosità</b> <i>Normal rotation precision, with greater need of noiselessness</i>	1
<b>Precisione di rotazione limitata, bassi carichi, minime esigenze di silenziosità</b> <i>Low rotation precision, low loads and minimal need of noiselessness</i>	0,5

## 4.3 CARICO RADIALE DINAMICO E STATICO EQUIVALENTE

Nelle tabelle dimensionali, vengono indicati i valori dei coefficienti di carico dinamico  $C_r$  e statico  $C_{0r}$ . Questi valori sono da considerarsi solamente quando il carico è puramente in direzione radiale; però i cuscinetti spesso sono soggetti a più carichi agenti, nonché ad altre situazioni, quali urti, vibrazioni ecc... pertanto occorre convertire il valore del carico dinamico radiale ed assiale in un unico valore chiamato carico radiale dinamico equivalente, per ottenere così i reali carichi applicati sui cuscinetti ed ottenere un valore molto simile alla durata del cuscinetto montato sul supporto. Il carico radiale statico rappresenta la controparte del carico radiale dinamico equivalente di un cuscinetto volvente.

## 4.3 EQUIVALENT RADIAL DYNAMIC AND STATIC LOAD

*The dynamic  $C_r$  and static  $C_{0r}$  load coefficient ratings are listed in the dimension tables. These ratings should be considered only when the load is purely in the radial direction; however, the bearings are often subject to several load agents, as well as other situations such as bumps, vibration etc.. therefore, the ratings of the dynamic radial and axial load should be converted to the same rating called the dynamic radial load equivalent. In this way, the rating of the real applied load obtained is very similar to the life of the bearing mounted on the housing. The static radial load represents the counterpart to the dynamic radial load equivalent of a bearing.*



## 5. GIUOCO DEI CUSCINETTI A SFERE

Uno dei principali fattori che può influenzare la durata del cuscinetto è il giuoco. Il giuoco del cuscinetto o giuoco interno (giuoco iniziale) rappresenta il valore di un cuscinetto prima di venir montato su di un albero o all'interno della sede d'alloggiamento. Il giuoco di un cuscinetto può essere inteso sia in senso radiale che assiale, quando lo spostamento dell'anello libero è in senso radiale si parlerà di giuoco radiale, mentre se il movimento è assiale, si parlerà di giuoco assiale del cuscinetto. Il giuoco radiale è determinato come il valore medio di varie misure dello spostamento totale sul piano perpendicolare all'asse del

## 5. CLEARANCE OF BALL BEARINGS

*One of the principal factors that can influence the life of a bearing is the clearance. The clearance of the bearing or the internal clearance (initial clearance) represents the rating of a bearing before mounting it on a shaft or inside of the housing case.*

*The clearance of a bearing can be intended both in a radial sense as well as an axial sense when the movement of the free ring is in the radial sense we say radial clearance while we say axial clearance if the movement is axial.*

*The radial clearance determines the average rating of the various measurements of the total movement on a plain which is*

cuscinetto. Tale spostamento è tipico di uno degli anelli del cuscinetto (l'altro è fisso) durante il rotolamento in varie direzioni angolari, sia rispetto all'anello rotante che a quello fisso e a diverse posizioni angolari della serie di sfere, rispetto agli anelli stessi.

Visti i diversi coefficienti di giuoco richiesti, i cuscinetti radiali possono essere costruiti secondo vari gruppi di giuoco iniziale. Di norma, i cuscinetti a sfere sono costruiti con giuoco radiale normale CN, che, ad impieghi comuni alla maggior parte dei casi, forniscono parametri soddisfacenti di funzionamento. Il giuoco radiale viene evidenziato con l'aggiunta alla sigla del cuscinetto della designazione della classe di precisione (C2, C3, C4, C5), mentre ai cuscinetti costruiti con un giuoco radiale corrispondente al gruppo normale CN non vengono assegnate ulteriori designazioni convenzionali. La durata della vita di un cuscinetto, può essere influenzata da diversi fattori, quali gli accoppiamenti di montaggio, le eventuali differenze di temperature tra l'anello interno e l'anello esterno ecc... da questo si deduce che la scelta del giuoco del cuscinetto è un fattore estremamente importante, perché oltre a determinarne la durata, influisce anche sulla rumorosità, sulle vibrazioni, sulla produzione di calore del cuscinetto. Il giuoco del cuscinetto deve garantirne un buon funzionamento, in particolar modo nel momento in cui potrebbero presentarsi delle contrazioni dell'anello esterno od interno, a seconda dell'applicazione. Le tabelle seguenti forniscono i valori di giuoco radiale.

*perpendicular to the axis of the bearing. Such movement is typical of one of the rings of the bearing (the other is fixed) during the rolling in various angular directions both with respect to the rotating ring and with respect to the fixed ring and the different angular positions of the series of spheres with respect to the rings themselves.*

*Considering the different coefficients of clearance required, the radial bearings can be constructed according to various initial groups.*

*As a norm, spherical bearings are constructed with a normal CN radial clearance that with common use in the majority of cases, supply satisfying functioning parameters. Radial clearance is indicated by an acronym on the bearing with the designation of the precision class (C2, C3, C4, C5), while the bearings constructed with a radial clearance corresponding to the normal group CN are not assigned an ulterior conventional designation.*

*The life of a bearing can be influenced by different factors accompanied by the mounting and eventual temperature differences between the internal and external ring etc... From this we deduce that the choice of the clearance of the bearing is an extremely important factor because besides determining the length, it influences the noiselessness, the vibration, the production of heat.*

*The clearance, of the bearing must guarantee good functioning, in particular, at the moment in which contractions of the external or internal ring may be present depending upon the application. The following table supplies radial clearance ratings.*

## 5.1 TIPOLOGIA GIUOCO RADIALE

## 5.1 TYPES OF RADIAL CLEARANCE

<b>Giuoco</b> Clearance	<b>Significato</b> Meaning	<b>Possibili condizioni operative</b> Possible working conditions
<b>C2</b>	<b>Giuoco radiale dei cuscinetti inferiore a CN</b> Radial clearance of bearings lower than CN	<b>Riduzione rumorosità e vibrazioni</b> Reduction of noisiness and vibrations
<b>CN</b>	<b>Giuoco radiale dei cuscinetti normale</b> Normal radial clearance of bearings	<b>Condizioni normali</b> Normal conditions
<b>C3</b>	<b>Giuoco radiale dei cuscinetti superiore a CN</b> Radial clearance of bearings higher than CN	<b>Montaggio con interferenze su entrambi gli anelli</b> Assembling with interferences on both rings
<b>C4</b>	<b>Giuoco radiale dei cuscinetti superiore a C3</b> Radial clearance of bearings higher than C3	<b>Errori di montaggio, albero e anello interno riscaldati</b> Assembling mistakes, shaft and inner rings heated
<b>C5</b>	<b>Giuoco radiale dei cuscinetti superiore a C4</b> Radial clearance of bearings higher than C4	<b>Albero riscaldato e alloggiamento raffreddato</b> Heated shaft and cooled housing

## Cuscinetto con foro cilindrico - Cylindrical bore bearings

Dimensioni - Dimensions:  $\mu\text{m}/0,0001''$

Dimensione del foro (d) Bore dimension (d)				Gioco radiale Radial clearance									
Oltre - Over		Fino a - Up to		C2		CN		C3		C4		C5	
mm mm	pollici inch	mm mm	pollici inch	min. max.	min. max.	min. max.	min. max.	min. max.	min. max.	min. max.	min. max.	min. max.	min. max.
2,5		10		0	7	2	13	8	23	14	29	20	37
	0,0984		0,3937		0	3		1	5		3	9	
10		18		0	9	3	18	11	25	18	33	25	45
	0,3937		0,7087		0	4		1	7		4	10	
18		24		0	10	5	20	13	28	20	36	28	48
	0,7087		0,9449		0	4		2	8		5	11	
24		30		1	11	5	20	13	28	23	41	30	53
	0,9449		1,1811		0,4	4		2	8		5	11	
30		40		1	11	6	20	15	33	28	46	40	64
	1,1811		1,5748		0,4	4		2	8		6	13	
40		50		1	11	6	23	18	36	30	51	45	73
	1,5748		1,9685		0,4	4		2	9		7	14	
50		65		1	15	8	28	23	43	38	61	55	90
	1,9685		2,5591		0,4	6		3	11		9	17	
65		80		1	15	10	30	25	51	46	71	65	105
	2,5591		3,1496		0,4	6		4	12		10	20	
80		100		1	18	12	36	30	58	53	84	75	120
	3,1496		3,9370		0,4	7		5	14		12	23	
100		120		2	20	15	41	36	66	61	97	90	140
	3,9370		4,7244		1	8		6	16		14	26	
120		140		2	23	18	48	41	81	71	114	105	160
	4,7244		5,5118		1	9		7	19		16	32	

## Cuscinetto con foro conico - Conical bore bearings

Dimensioni - Dimensions:  $\mu\text{m}/0,0001''$

Dimensione del foro (d) Bore dimension (d)				Gioco radiale Radial clearance								
Oltre - Over		Fino a - Up to		C2		CN		C3		C4		
mm mm	pollici inch	mm mm	pollici inch	min. max.	min. max.	min. max.	min. max.	min. max.	min. max.	min. max.	min. max.	
24		30		5	20	13	28	23	41	30	53	
	0,9449		1,1811		2	8		5	11		9	16
30		40		6	20	15	33	28	46	40	64	
	1,1811		1,5748		2	8		6	13		11	18
40		50		6	23	18	36	30	51	45	73	
	1,5748		1,9685		2	9		7	14		12	20
50		65		8	28	23	43	38	61	55	90	
	1,9685		2,5591		3	11		9	17		15	24
65		80		10	30	25	51	46	71	65	105	
	2,5591		3,1496		4	12		10	20		18	28
80		100		12	36	30	58	53	84	75	120	
	3,1496		3,9370		5	14		12	23		21	33
100		120		15	41	36	66	61	97	90	140	
	3,9370		4,7244		6	16		14	26		24	38
120		140		18	48	41	81	71	114	105	160	
	4,7244		5,5118		7	19		16	32		28	45



## 6. LUBRIFICAZIONE

Il processo di lubrificazione, ha il compito principale di evitare che vi possa essere eccessivo attrito tra le sfere, le piste di rotolamento e le gabbie, ridurre entro certi limiti la rumorosità di funzionamento, assicurare ai cuscinetti protezione dalla corrosione, oltre a diminuire anche l'eventuale attrito delle tenute. I supporti **KDF®** sono lubrificati con grassi che mantengono le proprie caratteristiche nel tempo, in condizioni normali d'esercizio. Qualora le condizioni d'esercizio lo richiedessero (condizioni esterne sfavorevoli, innalzamento della temperatura, aumento dei giri del cuscinetto), bisognerebbe procedere con ulteriori lubrificazioni, per consentire al cuscinetto di operare sempre nelle condizioni più favorevoli. Le tabelle riportate a seguito indicano quelli che sono i valori orientativi per i periodi di lubrificazione dei supporti ri-lubrificabili. Occorre precisare che esistono anche dei supporti esenti da manutenzione, di seguito esplicitati.

### 6.1 SUPPORTI ESENTI DA MANUTENZIONE

I supporti **KDF®** esenti da manutenzione, sono unità pronte al montaggio. I cuscinetti utilizzati in questo tipo di supporto contengono una tipologia di grasso d'elevata qualità, a base di litio saponificato, che ne consente un funzionamento continuo a temperature che possono variare dai  $-30^{\circ}\text{C}$  a  $+100^{\circ}\text{C}$ . Il sistema di tenuta garantisce ai cuscinetti di essere perfettamente protetti da eventuali agenti esterni inquinanti (polvere, umidità, fluidi vari) e di prevenire la fuoriuscita del grasso. La rotazione stessa dell'albero consente la circolazione del grasso e la lubrificazione stessa all'interno del cuscinetto si mantiene per un lungo periodo. I principali vantaggi nell'utilizzo di supporti esenti da manutenzione sono raggruppabili con quanto sotto riportato:

- maggior resistenza ad eventuali infiltrazioni d'agenti inquinanti esterni
- mancanza di dispersioni del grasso utilizzato per la lubrificazione
- unità compatta, perché non vi sono dispositivi di lubrificazione
- risparmio in termini di tempo e costi di manutenzione

## 6. LUBRICATION

*The lubrication process is meant principally to avoid excessive wear between the sphere, the rolling track and the cage to reduce to certain limits the noise level of functioning, assure the protection of the bearing against corrosion and furthermore to diminish eventual wear from the seal. **KDF®** housings are lubricated with grease that maintains its characteristics over time during normal exercise conditions.*

*When conditions require (external unfavourable conditions, increased temperature, increased rounds of the bearing), an ulterior greasing should be done in order to permit the bearing to always operate in more favourable conditions. The following table indicates what the guideline ratings are for the periods of lubrication of housings which can be lubricated again. We should note that some housings exist which do not require maintenance and this is explained as follows.*

### 6.1 MAINTENANCE-FREE BEARING UNITS

***KDF®** housings which are exempt from maintenance are units which are ready to be mounted. The bearings used in this type of housing contain a high quality type of grease made of saponified lithium which allows the functioning to continue at temperatures which vary from  $-30^{\circ}\text{C}$  to  $+100^{\circ}\text{C}$ . The sealing system guarantees that the bearings are perfectly protected from eventual external pollutants (dust, humidity, various fluids) and it prevents the grease from exiting. The rotation of the shaft itself permits the grease to circulate and the lubrication itself inside the bearing maintains itself for a long period. The main advantages of using these housings is that they are exempt for maintenance and are regrouped as reported below:*

- *increased resistance to eventual infiltration from pollutants*
- *no dispersion of grease used to lubricate*
- *compact units because there are no lubrication devices*
- *savings in terms of time and the expense of maintenance*

## 6.2 SUPPORTI RI-LUBRIFICABILI

I supporti **KDF®** nelle versioni in ghisa ed in acciaio inox possono essere forniti con apposito ingrassatore che consente periodicamente d'effettuare la ri-lubrificazione del cuscinetto. Il foro dove è posizionato l'ingrassatore può creare un indebolimento della struttura del supporto, anche se da studi effettuati, la posizione del foro è posta in modo tale da rendere minimo l'effetto sopra citato. In condizioni normali è preferibile l'utilizzo di supporti esenti da manutenzione, anche se vi sono comunque applicazioni dove risulta indispensabile l'utilizzo di supporti ri-lubrificabili, come nei casi citati di seguito:

- utilizzo in condizioni estremamente critiche, ove non sia possibile l'utilizzo di ulteriori dispositivi di chiusura (coperchi di protezione)
- utilizzo su macchinari che lavorano ad intermittenza e dove sono presenti agenti inquinanti esterni
- utilizzo in casi dove la rotazione risulta elevata e si possono avere problemi di rumorosità
- utilizzo del supporto con temperature superiori ai +140°C

In condizioni normali d'utilizzo dei supporti **KDF®** la quantità di grasso presente nel cuscinetto è sufficiente per tutta la durata della vita del supporto. Con il verificarsi di condizioni esterne sfavorevoli, come elevate variazioni termiche, numero di giri più elevati, sarà indispensabile valutare adeguatamente questi fattori perché possono notevolmente influire sugli intervalli di lubrificazione.

## 6.3 PERIODICITÀ DELLA LUBRIFICAZIONE

I valori, riportati nella sotto indicata tabella, sono relativi agli intervalli di lubrificazione, per un funzionamento approssimativo di 8 ore giornaliere.

Temperatura Temperature	Condizioni d'impiego - Working conditions			Cuscinetto Bearing	Grasso Grease
	Ordinarie Normal	Polvere Dust	Polvere ed umidità Dust and damp		
50°C ➤ 50°C 50°C ➤ 70°C 70°C ➤ 100°C	360/720 giorni/days 360 giorni/days 180 giorni/days	360 giorni/days 120 giorni/days 60 giorni/days	120 giorni/days 30 giorni/days 15 giorni/days	Normale Normal	Litio Lithium
100°C ➤ 120°C 120°C ➤ 150°C	60 giorni/days 15 giorni/days	15 giorni/days 5 giorni/days	5 giorni/days 2 giorni/days	Termoresistente Heat-resistant	Calcio Calcium
150°C ➤ 180°C 180°C ➤ 200°C	7 giorni/days 3 giorni/days	2 giorni/days 1 giorno/days	1 giorno/days 1 giorno/days	Termoresistente Heat-resistant	Speciale Special

## 6.2 RE-GREASEABLE BEARING UNITS

The **KDF®** housing units in the cast iron version and in the stainless steel version can be supplied with the necessary lubricator which permits periodic re-greasing of the bearings. The bore where the greaser is positioned can create a weakness in the structure of the housing, even if studies performed, the position of the bore is located in such a way as to render the effects of the above mentioned minimal. In normal conditions it is preferable to use housings which are exempt from maintenance. Even so, there are, in any case, some applications where the use of re-grease bearings is indispensable, as in the case cited below:

- use in extremely critical conditions, where it is not possible to use ulterior closure devices (protective covers)
- use on machines that work at intermittence and where external pollutant agents are present.
- use in cases where the number of rotations are elevated and the may be noise problems.
- use when temperatures are above +140° C.

**KDF®** housing units used in normal conditions, contain a quality grease inside the bearing which is sufficient for all of the life of the bearing. As unfavourable external conditions such as elevated thermal variations, the number of rounds increased, are verified it will be indispensable to evaluate adequately these factors because the can notably influence the lubrication intervals.

## 6.3 PERIODICITY OF LUBRICATION

The ratings, indicated in the table below, are relative to the intervals of lubrication for functioning approximately 8 hours per day.

## 6.4 ACCORGIMENTI PER LA LUBRIFICAZIONE

I supporti possono essere ri-lubrificati attraverso l'apposito ingrassatore (tipo a sfera), che si trova sulla parte esterna del supporto. Il grasso viene inserito gradualmente nell'ingrassatore (1) ed attraverso un canaletto (2) che si trova nella parte interna del supporto raggiunge due fori (3) che permettono l'ingresso del grasso nel cuscinetto. Si prega di prestare sempre molta attenzione a quanto segue:

- evitare l'ingrassaggio al primo montaggio
- non utilizzare mai olio per la lubrificazione
- utilizzare sempre il grasso raccomandato
- pulire bene l'ingrassatore da eventuali impurità
- inserire il grasso in maniera graduale e lenta, facendo possibilmente ruotare l'albero
- non introdurre mai quantità eccessive di grasso (potrebbe comprometterne il funzionamento)
- se il cuscinetto è stato smontato, prestare particolare attenzione a quando viene rimontato, in modo tale che la parte prolungata dell'anello interno sporgente (4) sia dallo stesso lato dell'ingrassatore, perché solo in questa posizione è possibile la ri-lubrificazione del supporto.

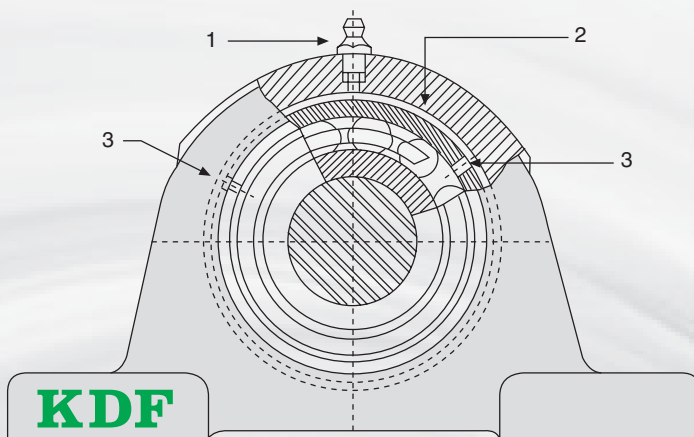

## 6.4 RULES FOR LUBRICATION

The housings can be re-lubricated using the greaser supplied for that purpose (sphere type), which can be found on the external part of the housing. The grease is inserted gradually in the greaser (1) and using the small canal (2) which can be found in the internal part of the housing, reach two holes (3) which permit the entry of the grease into the bearing. We recommend that careful attention be given to the following:

- avoid using grease when first mounting
- do not ever use oil to lubricate
- always use the grease recommended
- clean the greasing tool well from eventual impurities
- insert the grease in a gradual and slow manner making the shaft rotate if possible
- never introduce excessive quantities of grease (they could compromise the functioning)
- if the bearing has been dismantled, give careful attention to remounting so that the prolonged part of the internal ring which sticks out (4) is from the same side as the greaser because this is the only position in which it is possible to re-lubricate the housing

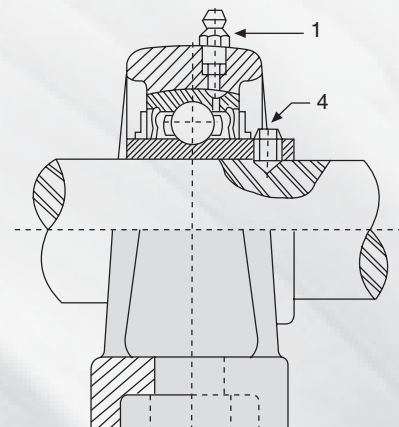



## 6.5 QUANTITÀ DI GRASSO

Normalmente i cuscinetti per supporti **KDF®** sono riempiti circa al 30-35%, percentuale adatta per la maggior parte delle applicazioni più comuni. Se i cuscinetti fossero riempiti con una quantità maggiore, questo provocherebbe una fuori uscita del grasso, ed anche in virtù della resistenza che si verrebbe a creare, ci sarebbe un effetto di surriscaldamento. Nelle lubrificazioni periodiche si consiglia di attenersi quanto più alla quantità di grasso indicata nella sotto riportata tabella. Per impieghi a basse velocità i valori riportati in tabella possono anche aumentare, non oltre il doppio di quanto indicato.

Tipologia di cuscinetto Bearing type			Quantità (g) Quantity (g)
UC 201	-	-	1,6
UC 202	-	-	1,6
UC 203	-	-	1,6
UC 204	-	-	1,6
UC 205	-	UK 205	1,6
UC 206	UCX 05	UK 206	3,1
UC 207	UCX 06	UK 207	4
UC 208	UCX 07	UK 208	5
UC 209	UCX 08	UK 209	5,7
UC 210	UCX 09	UK 210	6,7
UC 211	UCX 10	UK 211	8,6
UC 212	UCX 11	UK 212	11,7
UC 213	UCX 12	UK 213	13,5
UC 214	UCX 13	UK 214	16,2
UC 215	UCX 14	UK 215	18
UC 216	UCX 15	UK 216	22,5
UC 217	UCX 16	UK 217	27,5
UC 218	UCX 17	UK 218	35
-	UCX 18	-	47
-	UCX 20	-	67
-	-	-	-

## 6.5 GREASE QUANTITY

Normally the bearings for the **KDF®** housings are filled to 30-35%, the suitable percentage for most common applications.

*If the bearings were to be filled with a larger quantity, this would provoke the grease to overflow and also with resistance that would be created there would be an overheating effect.*

*When lubricating periodically, it is advisable to use the quantities of grease indicated in the table below. For low speed uses, the values in the table can even increase but not more than double the amount indicated.*

Tipologia di cuscinetto Bearing type		Quantità (g) Quantity (g)
UC 305	UK 305	4
UC 306	UK 306	5,4
UC 307	UK 307	7,3
UC 308	UK 308	9,5
UC 309	UK 309	11,9
UC 310	UK 310	16,1
UC 311	UK 311	21
UC 312	UK 312	26,5
UC 313	UK 313	31,5
UC 314	UK 314	40
UC 315	UK 315	47,5
UC 316	UK 316	55,5
UC 317	UK 317	65
UC 318	UK 318	76
UC 319	UK 319	91,5
UC 320	UK 320	116,5
UC 321	UK 321	135
UC 322	UK 322	164
UC 324	UK 324	196
UC 326	UK 326	242
UC 328	UK 328	288,5

## 6.6 INGRASSATORI

In linea di massima, quasi tutti i supporti **KDF®** sono forniti con apposito ingrassatore in ottone, tipo standard (su richiesta anche zincato o in acciaio inox). Per poter effettuare l'ingrassaggio, sarà necessario utilizzare l'apposito attrezzo. Qualora vi fossero delle necessità particolari d'applicazione è possibile fornire anche altri tipi di ingrassatori, come riportato nei seguenti disegni.



Ottone - Zincati - Acciaio inox  
Brass - Galvanized - Stainless steel

Disponibile solo su richiesta - Available on request

## 6.6 GREASE NIPPLE

Most **KDF®** housings are furnished with the right grease nipple in brass as a standard type (upon request also zinc or stainless steel plated) In order to carry out greasing, it will be necessary to use the proper tool. Should there be necessity for a particular application it is possible to supply other types of grease nipple as can be seen in the following diagrams.

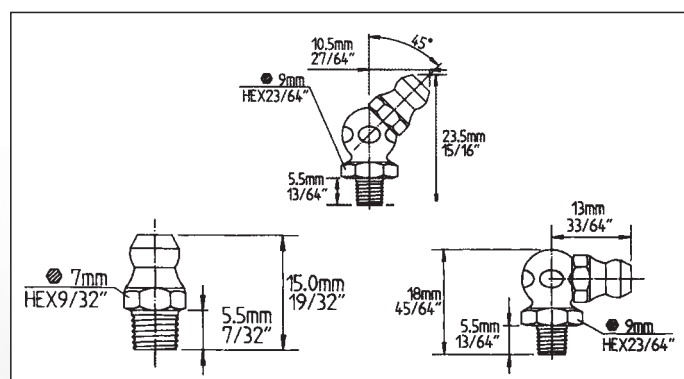

Tipo standard - Standard type

## 6.7 TABELLA DEI LUBRIFICANTI

I lubrificanti per cuscinetti utilizzati nei supporti **KDF®**, dovranno rispondere ai seguenti requisiti:

- essere stabili, sia a livello fisico che chimico
- essere privi di corpi estranei provenienti da componenti meccanici (quali abrasivi, sostanze metalliche ecc...)
- garantire un coefficiente minimo d'attrito
- avere una buona capacità lubrificante

La seguente tabella, esplica quelli che sono i lubrificanti comunemente utilizzati nonché le loro principali caratteristiche.

## 6.7 TABLES OF LUBRIFICANTS

The lubricants for bearings used in **KDF®** housings should respond to the following requirements:

- be stable, both on a physical as well as a chemical level
- be exempt foreign bodies originating from mechanical components (abrasives, metallic substances etc...)
- guarantee a minimum coefficient of rubbing
- have a good lubricating capacity

The following table explains which are the common lubricants used as well as their principle characteristics.

Marca e tipo <i>Brand name</i>	Grasso base <i>Basic type grease</i>	Temperatura d'esercizio <i>Operating temperature</i>	Caratteristiche <i>Characteristics</i>
<b>Exxon Beacon 325</b>	Grasso sintetico <i>Synthetic grease</i>	- 55 ➤ + 120°C	Grasso generico <i>General grease</i>
<b>Chevron SRI-2</b>	Grasso minerale <i>Mineral grease</i>	- 35 ➤ + 180°C	Indicato alle alte temperature con buona resistenza all'acqua <i>High temperature range with good water resistance</i>
<b>Shell Alvania 2</b>	Grasso minerale <i>Mineral grease</i>	- 35 ➤ + 120°C	Lunga durata <i>Long life</i>
<b>DuPont Krytox 240AC (Mil-G-27617)</b>	Grasso fluorato <i>Fluorinate grease</i>	- 35 ➤ + 290°C	Indicato per altissime temperature. Non perde le proprietà lubrificanti (costo elevato) <i>High temperature stability with good lubricating properties sand (very high price)</i>
<b>Shell Dolium R</b>	Grasso di petrolio <i>Petroleum grease</i>	- 40 ➤ + 150°C	Resistente alla corrosione ed all'acqua <i>Good corrosion resistance and water washout properties</i>
<b>KYODO SRL</b>	Grasso sintetico <i>Synthetic grease</i>	- 40 ➤ + 150°C	Bassa rumorosità e bassi carichi <i>Low noise and low torque applications</i>
<b>Mobil HP</b>	Litio <i>Lithium complex</i>	- 30 ➤ + 110°C	Resistente alla corrosione ed alle vibrazioni, velocità moderate <i>Vibration, moderate speeds and good corrosion resistance</i>



## 7. MONTAGGIO E SMONTAGGIO

I supporti **KDF®** normalmente vengono forniti già montati e solitamente confezionati singolarmente. Occorre prestare attenzione nel momento dell'apertura della confezione, che non vadano persi eventuali accessori aggiunti, come ad esempio chiavi ed ingrassatori. I supporti **KDF®** sono agevolmente montabili fin dall'inizio, occorre comunque prestare attenzione a quanto sotto riportato, per consentire al supporto di avere una normale vita d'esercizio:

- assicurarsi che la superficie dove viene montato il supporto sia sufficientemente rigida e piana
- evitare disallineamenti oltre i  $\pm 2^\circ$  tra la superficie dove viene montato il supporto e l'asse dell'albero

## 7. MOUNTING AND DISASSEMBLY

***KDF®** bearing units are normally furnished already mounted and singularly packaged. Care should be taken while opening the package so that eventual added accessories such as keys and grease nipple are not lost.*

***KDF®** bearing units are easily to mount without prior know how, it is however important to give attention to the following points in order to have a normal live span of the unit:*

- *ascertain that the surface where the unit will be mounted is sufficiently rigid and flat.*
- *avoid misalignments outside of  $\pm 2^\circ$  between the surface where the unit is to be mounted and the axis of the shaft.*

### 7.1 FISSAGGIO CON GRANI

Il fissaggio del cuscinetto all'albero avviene attraverso l'avvitamento di due grani che si trovano sulla superficie del cuscinetto stesso (fig. A). Per razionalizzare tale operazione è consigliabile effettuare quanto segue: appiattire leggermente l'albero nella zona del grano di fissaggio (fig. 1) oppure ricavare un leggero incavo (fig. 2). Nel caso si proceda con l'incavo occorre prestare molta attenzione affinché non vi siano spostamenti assiali che possano deformare il cuscinetto. I grani di fissaggio dovrebbero essere serrati il più possibile, in modo da evitare qualsiasi spostamento dell'anello interno sull'albero. **Si raccomanda di non stringere eccessivamente i grani**, che potrebbero causare una deformazione dell'anello interno, con conseguente deformazione dello stesso e causare uno scorrimento non uniforme. I grani di fissaggio andranno montati seguendo i valori indicati nelle sotto riportate tabelle. Se il cuscinetto dovesse essere soggetto a forti oscillazioni o carichi assiali, è consigliabile ricavare sull'albero uno spallamento (fig. 3) in modo tale da bloccare l'anello interno con un dado contro lo spallamento stesso.

### 7.1 SETSCREWS FIXING

*The fixing of the bearing to the shaft takes place using setscrews the are located on the surface of the bearing itself (fig. A). To realize such an operation it is advisable to do the following:*

*flatten slightly the shaft in the zone where the setscrew will be fixed (fig. 1) or hollow out a small cavity (fig. 2). In the case of the cavity, be very careful that there are no axial movements that could deform the bearing.*

*The setscrews should be tightened as much as possible in such a way as to avoid movement of the ring inside the shaft. **We recommend however not to over tighten or tighten excessively the setscrews** however as they could cause a deformation of the internal ring with consequent deformation of the bearing and cause non uniform running. The setscrews will be mounted according to the values indicated on the table below. If the bearing should be subject to strong oscillations or axel loads, it is advisable to hollow out a support to the shaft in such a way as to block the internal ring with a nut against the support itself.*

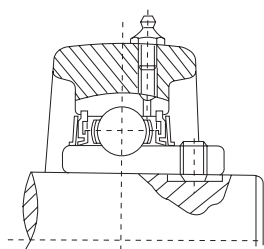

Fig. 1

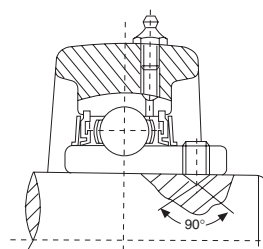

Fig. 2

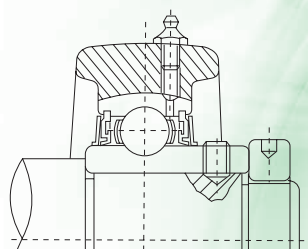

Fig. 3



Fig. A

Coppie di serraggio raccomandate (serie metriche)  
Recommended locking torque (metric series)

Tipologia di cuscinetti Bearings type			Sigla grani Designation setscrews	Coppia di serraggio Locking torque Nm (max)
UC 201	-	-	M 6x1	3,9
UC 206	-	-	M 6x1	3,9
-	-	UC 305 UC 306	M 6x1	4,9
-	UCX 05	-	M 6x1	5,8
UC 207	-	-	M 8x1	7,8
UC 209	-	-	M 8x1	7,8
-	UCX 06 UCX 08	UC 307	M 8x1	9,8
-	UCX 09	-	M 10x1	16,6
UC 210	-	UC 308	M 10x1	19,6
UC 213	-	UC 309	M 10x1	19,6
-	UCX 10	-	M 10x1	22,5
-	UCX 11 UCX 12	-	M 10x1	24,5
UC 214	UCX 13	UC 310	M 12x1,5	28
UC 218	UCX 16	UC 314	M 12x1,5	28
-	UCX 17	-	M 12x1,5	34,3
-	UCX 18	UC 315 UC 316	M 14x1,5	34,3
-	UCX 20	UC 317 UC 319	M 16x1,5	53,9
-	-	UC 320 UC 324	M 18x1,5	58,8
-	-	UC 326 UC 328	M 20x1,5	78,4

Coppie di serraggio raccomandate (serie in pollici)  
Recommended locking torque (inches series)

Tipologia di cuscinetti Bearings type			Sigla grani Designation setscrews	Coppia di serraggio Locking torque lbf-inch (max)
UC 201	-	-	1/4 - 28 UNF	34
UC 206	-	-	1/4 - 28 UNF	34
-	-	UC 305 UC 306	1/4 - 28 UNF	43
-	UCX 05	-	1/4 - 28 UNF	52
UC 207	-	-	5/16 - 24 UNF	69
UC 209	-	-	5/16 - 24 UNF	69
-	UCX 06 UCX 08	UC 307	5/16 - 24 UNF	86
-	UCX 09	-	3/8 - 24 UNF	147
UC 210	-	UC 308	3/8 - 24 UNF	173
UC 213	-	UC 309	3/8 - 24 UNF	173
-	UCX 10	-	3/8 - 24 UNF	199
-	UCX 11 UCX 12	-	3/8 - 24 UNF	216
UC 214	UCX 13	UC 310	7/16 - 20 UNF	260
UC 218	UCX 16	UC 314	7/16 - 20 UNF	260
-	UCX 17	-	1/2 - 20 UNF	303
-	UCX 18	UC 315 UC 316	9/16 - 18 UNF	303
-	UCX 20	UC 317 UC 319	5/8 - 18 UNF	477
-	-	UC 320	5/8 - 18 UNF	520
-	-	-	-	-

Coppie di serraggio raccomandate (serie metriche)  
*Recommended locking torque (metric series)*

Tipologia di cuscinetti <i>Bearings type</i>	Sigla grani <i>Designation setscrews</i>	Coppia di serraggio <i>Locking torque Nm (max)</i>
SB - RB 201 SB - RB 203	M 5x0,8	3,4
SB - RB 204 SB - RB 206	M 6x1	4,4
SB - RB 207 SB - RB 209	M 8x1	6,8

Coppie di serraggio raccomandate (serie in pollici)  
*Recommended locking torque (inches series)*

Tipologia di cuscinetti <i>Bearings type</i>	Sigla grani <i>Designation setscrews</i>	Coppia di serraggio <i>Locking torque lbf-inch (max)</i>
SB - RB 201 SB - RB 203	10-32 UNF	34
SB - RB 204 SB - RB 206	¼ - 28 UNF	43
SB - RB 207 SB - RB 209	5/16 - 24 UNF	69

## 7.2 FISSAGGIO CON BUSSOLA DI TRAZIONE

Quando si vuole procedere al montaggio della bussola di trazione, occorre posizionare il supporto su di una superficie, perfettamente piana (è consigliabile lasciare i bulloni di fissaggio leggermente allentati, per poi stringerli ad operazione avvenuta). Introdurre la bussola in modo tale che la parte conica si trovi quasi al centro del cuscinetto e battere leggermente con un attrezzo, l'intera superficie laterale della bussola. Procedere con l'inserimento della rondella e stringere a fondo la ghiera con apposita chiave. **Si raccomanda di non stringere troppo la ghiera**, perché potrebbero causarsi delle deformazioni, pertanto attenersi ai valori sotto indicati. Al termine delle operazioni sopra elencate, provare la rotazione manuale dell'albero e verificare che ruoti agevolmente.

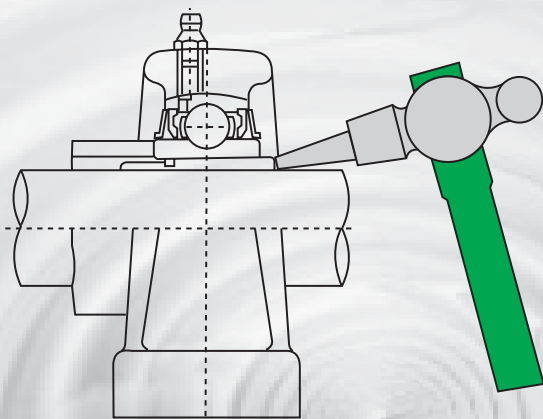

## 7.2 TAPER ADAPTER FIXING

Once ready to proceed with the mounting of the taper adapter, it is necessary to position the support on a perfectly flat surface (it's a good idea to leave the fixing bolts slightly loose and then tighten them once the operation is complete). Introduce the taper adapter with the conical part nearly at the centre of the bearing and with a tool, hit the entire lateral surface of the bolt lightly. Proceed to insert the washer and tighten completely the ferrule/ring with the proper key. **Attention: over tightening the ferrule could cause deformations** therefore, stay within the values indicated below.

At the end of the operation mentioned above, try to manually rotate the shaft and verify that it rotates with ease.



Coppie di serraggio raccomandate (serie metriche)

Recommended locking torque (metric series)

Tipologia dei cuscinetti <i>Bearings type</i>	Bussola di trazione <i>Taper adapter</i>	Coppia di serraggio - Locking torque	
		Kg. - cm	Nm (max)
UK 205	H 205	254	25
UK 206	H 206	305	30
UK 207	H 207	407	40
UK 208	H 208	509	50
UK 209	H 209	612	60
UK 210	H 210	764	75
UK 211	H 211	1 019	100
UK 212	H 212	1 325	130
UK 213	H 213	1 529	150
UK 215	H 215	1 732	170
UK 216	H 216	2 038	200
UK 217	H 217	2 344	230
UK 218	H 218	2 752	270

### 7.3 FISSAGGIO CON ANELLO ECCENTRICO DI SERRAGGIO

Un altro sistema utilizzabile per il fissaggio tra il cuscinetto e l'albero, può avvenire attraverso l'utilizzo di un anello eccentrico di serraggio. In questo caso l'albero e l'anello interno verranno collegati proprio serrando l'anello eccentrico nel senso di rotazione dell'albero. Nel montaggio del supporto con anello eccentrico di serraggio, assicurarsi di compiere correttamente le seguenti operazioni; accertarsi che la superficie dove verrà installato il supporto sia idonea per quell'applicazione; verificare che l'estremità dell'albero sia priva di bave e che la vite di bloccaggio dell'anello eccentrico non fuoriesca dalla parte dell'albero; assicurarsi che il supporto sia ben bloccato alla superficie e che non vi siano possibilità di carichi assiali eccessivi; inserire l'anello eccentrico facendolo girare nel senso di rotazione e con apposito strumento battere in modo da fissare l'anello eccentrico; al termine di queste operazioni serrare la vite di bloccaggio presente sul collare attenendosi ai valori riportati nelle sotto indicate tabelle. Questo sistema di fissaggio non è particolarmente indicato per applicazioni nelle quali gli alberi possono variare il senso di rotazione.

### 7.3 ECCENTRIC COLLAR LOCKING FIXING

*Another system that can be used to fix the bearing and the shaft is to use the eccentric collar locking system. In this case the shaft and the internal ring actually linked by tightening the eccentric ring in the rotation direction of the shaft.*

*When mounting the eccentric collar locking system support, be sure to correctly perform the task; ascertain that the surface where it will be installed is fit for this application; verify that the edge of the shaft has no metal burr and that the blocking screws of the eccentric ring does not protrude out of the shaft; make sure that the support is securely fastened to the surface and that there is no possibility for excessive axial loads.*

*Insert the eccentric ring by turning, in the rotation direction, and with the proper tool, strike it so as to fix the eccentric ring. At the end of this operation, tighten the blocking screw present on the collar staying within the limits indicated on the table below. This fixing system is not particularly indicated for applications in which the shafts can rotate in different directions.*

## Coppie di serraggio raccomandate (serie metriche) Recommended locking torque (metric series)

Tipologia di cuscinetti Bearings type			Sigla grani Designation setscrews	Coppia di serraggio Locking torque Nm (max)
HC 204	-	SA 201	M 6x1	7,8
HC 205	-	SA 205		
HC 206	HC 303	SA 206	M 8x1	9,8
HC 210	HC 307	SA 211		
HC 211	HC 308	SA 212	M 10x1	29,4
HC 215	HC 312			
-	HC 313	-	M 12x1,5	34,3
-	HC 314	-		
-	HC 315	-	M 16x1,5	53,9
-	HC 317	-		
-	HC 318	-	M 20x1,5	78,4
-	HC 320	-		

## Coppie di serraggio raccomandate (serie in pollici) Recommended locking torque (inches series)

Tipologia di cuscinetti Bearings type			Sigla grani Designation setscrews	Coppia di serraggio Locking torque lbf-inch (max)
HC 204	-	SA 201	1/4 - 28 UNF	69
HC 205	-	SA 205		
HC 206	HC 303	SA 206	5/16 - 24 UNF	86
HC 210	HC 307			
HC 211	HC 308	SA 212	3/8 - 24 UNF	260
HC 215	HC 312			
-	HC 313	-	1/2 - 20 UNF	350
-	HC 314	-		
-	HC 315	-	5/8 - 18 UNF	520
-	HC 317	-		
-	HC 318	-	3/4 - 16 UNF	700
-	HC 320	-		

## 7.4 MOVIMENTO ASSIALE DOVUTO ALL'ESPANSIONE O AL RESTRINGIMENTO

Succede spesso che in presenza di alcune particolari condizioni di lavoro, l'albero si possa espandere o restringere, e che quindi il cuscinetto si possa muovere.

L'albero della ruota del camion per esempio (mozzo), deve essere mosso in direzione assiale al limite: quando l'albero viene utilizzato a temperature elevate, l'espansione termica fa sì che lo stesso diventi più largo e lungo.

Se i cuscinetti sono tutti fissati sull'albero si verifica sul cuscinetto un carico assiale straordinario, e anche a causa dell'espansione termica potrebbe verificarsi una rottura del cuscinetto stesso.

Per questa ragione, in presenza di espansioni o restringimenti dell'albero bisogna utilizzare un supporto fisso da un lato e uno mobile dall'altro.

## 7.4 AXIAL MOVEMENT DUE TO EXPANSION AND SHRINKAGE

*It often happens that in the presence of some particular working conditions, the shaft may expand or shrink and therefore the bearings may move.*

*The shaft of the wheels of a truck for example, should be moved in the axial direction to the limit: when the shaft is used at high temperatures, thermal expansion takes place and the shaft becomes wider and longer.*

*If the bearings are all attached to the shaft the bearing will be have an extraordinary axial load and could even break due to the thermal expansion.*

*This is why, in the presence of an expanding or shrinking shaft, fixed support on one side or a mobile one from the other should be used.*



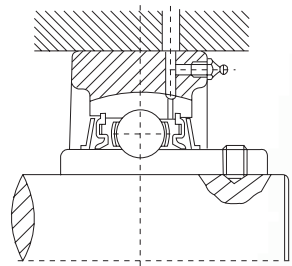

FIG. 1

Fig.1) Come mostrato, è consigliabile utilizzare il tipo di supporto a cartuccia con cuscinetto avente diametro esterno cilindrico, nella stessa maniera che con i soliti cuscinetti. Quando si utilizzano supporti a cartuccia, bisogna prestare attenzione a non causare una deformazione nel momento dell'inserimento. Tutto il corpo della struttura come sopra mostrato, è preparato per essere utilizzato con alte temperature.

Fig.2) Ad ogni modo la chiave è lavorata sull'albero, e generalmente al posto dei grani di fissaggio viene utilizzata una vite a testa esagonale. Il movimento assiale causato dall'espansione o dal restringimento dell'albero è regolato da questo.

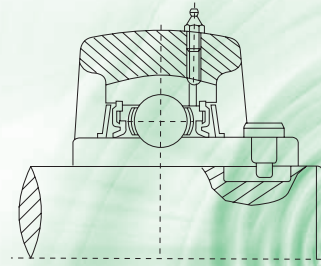

FIG. 2

Fig.1) As shown it is desirable to use a cartridge type bearing with a cylindrical outer diameter in the same manner as with ordinary bearings. When using cartridge type housings, be careful not to cause a deformation at the time of insertion. The complete housing with the above shown structure is prepared for use at high temperatures.

Fig.2) The key is machined on the shaft and a dog point hexagon hollow setscrew is generally used in place of the setscrew. Axial movement due to shaft expansion and shrinkage is in this way regulated.

## 7.5 SMONTAGGIO DEL SUPPORTO

Se per una qualsiasi ragione, si rende necessaria la sostituzione del supporto, occorre ripercorrere le stesse operazioni che si erano effettuate per il montaggio, ma al contrario. È importante prestare attenzione particolare ai seguenti aspetti:

- nel caso il supporto sia stato fissato con i grani di bloccaggio, è importante svitare completamente gli stessi, in modo tale da evitare che nel momento dello smontaggio, i grani non possano in alcun modo strisciare sull'albero segnandolo
- nel caso il supporto sia stato utilizzato con bussola di trazione, occorre sollevare la linguetta della rondella e svitare leggermente la ghiera, dopodiché appoggiando un anello, battere con apposito attrezzo su tutta la superficie della ghiera, fin tanto che non si può estrarre la bussola. Fare molta attenzione a non danneggiare le filettature.

## 7.6 SOSTITUZIONE DEL CUSCINETTO

Se per una qualsiasi ragione, si rendesse necessario sostituire il cuscinetto presente all'interno del supporto, questo non significa che debba essere sostituito anche il corpo del supporto. Per effettuare tale operazione occorre che le viti di bloccaggio siano ben fissate, per non interferire nelle operazioni di sostituzione. Utilizzando un tubo o un attrezzo simile, ed inserendolo all'interno del foro del cuscinetto, quest'ultimo dovrà essere fatto ruotare di circa 90° facendo in modo di estrarlo dalle guide ricavate all'interno della fusione del supporto; dopodiché si procederà nell'operazione inversa per inserire il nuovo cuscinetto.

## 7.5 DISASSEMBLY OF BEARING UNIT

If for any reason, it becomes necessary to substitute the housing, the same operation as was done while mounting must be carried out, but in reverse. Give careful attention to the following aspects:

- If the housing had been fixed with setscrews, it is important to unscrew them completely to keep them from sliding against the shaft while dismounting.
- If the taper adapter has been used to fix the housing, lift the lip of the washer and unscrew slightly the lock nut then while supporting the ring, strike with the proper tool on the surface of the lock nut until the taper adapter can be extracted. Be very careful not to damage the threading.

## 7.6 BEARING REPLACEMENT

If for any reason it becomes necessary to substitute the internal bearing of the housing, this does not mean that the housing must also be substituted. To do such an operation the blockage screws are well fixed so as not to interfere with the substitution operation. Using a tube or a similar tool and inserting it inside the bore in the bearing and rotating the bearing about 90° in such a way as to extract it from the guide hollowed out inside the casting of the housing; after which proceed inversely to insert the new bearing.



## 8. TABELLA CONVERSIONE DUREZZE

## 8. CONVERSION TABLE OF HARDNESS

Durezza <b>ROCKWELL</b> Hardness Scala <b>C</b> C Scale	Durezza <b>VICKERS</b> Hardness	Durezza <b>BRINNEL</b> Hardness		Durezza <b>ROCKWELL</b> Hardness		Durezza <b>SHORE</b> Hardness
		Sfera Standard Ball	Sfera <sup>1)</sup> Ball <sup>1)</sup>	Scala <b>A</b> Scale <b>A</b>	Scala <b>B</b> Scale <b>B</b>	
68	940	-	-	85,6	-	97
67	900	-	-	85,0	-	95
66	865	-	-	84,5	-	92
65	832	-	739	83,9	-	91
64	800	-	722	83,4	-	88
63	772	-	705	82,8	-	87
62	746	-	688	82,3	-	85
61	720	-	670	81,8	-	83
60	697	-	654	81,2	-	81
59	674	-	634	80,7	-	80
58	653	-	615	80,1	-	78
57	633	-	595	79,6	-	76
56	613	-	577	79,0	-	75
55	595	-	560	78,5	-	74
54	577	-	543	78,0	-	72
53	560	-	525	77,4	-	71
52	544	500	512	76,8	-	69
51	528	487	496	76,3	-	68
50	513	475	481	75,9	-	67
49	498	464	469	75,2	-	66
48	484	451	455	74,7	-	64
47	471	442	443	74,1	-	63
46	458	432	432	73,6	-	62
45	446	421	421	73,1	-	60
44	434	409	409	72,5	-	58
43	423	400	400	72,0	-	57
42	412	390	390	71,5	-	56
41	402	381	381	70,9	-	55
40	392	371	371	70,4	-	54
39	382	362	362	69,9	-	52
38	372	353	353	69,4	-	51
37	363	344	344	68,9	-	50
36	354	336	336	68,4	(109,0)	49
35	345	327	327	67,9	(108,5)	48
34	336	319	319	67,4	(108,00)	47
33	327	311	311	66,8	(107,5)	46
32	318	301	301	66,3	(107,0)	44
31	310	294	294	65,8	(106,0)	43
30	302	286	286	65,3	(105,5)	42
29	294	279	279	64,7	(104,5)	41
28	286	271	271	64,3	(104,0)	41
27	279	264	264	63,8	(103,0)	40
26	272	258	258	63,8	(102,5)	38
25	266	253	253	62,8	(101,5)	38
24	260	247	247	62,4	(101,0)	37
23	254	243	243	62,0	100,0	36
22	248	237	237	61,5	99,0	35
21	243	231	231	61,0	98,5	35
20	238	226	226	60,5	97,8	34
(18)	230	219	219	-	96,7	33
(16)	222	212	212	-	95,5	32
(14)	213	203	203	-	93,9	31
(12)	204	194	194	-	92,3	29
(10)	196	187	187	-	90,7	28
(8)	188	179	179	-	89,5	27
(6)	180	171	171	-	87,1	26
(4)	173	165	165	-	85,5	25
(2)	166	158	158	-	83,5	24
(0)	160	152	152	-	81,7	24

<sup>1)</sup> al carbonio di tungsteno - tungsten carbon material's

## 9. TABELLA CONVERSIONE POLLICI/MILLIMETRI

## 9. CONVERSION TABLE OF INCH/MILLIMETRES

1" = 25,4 mm

Pollici - Inch		Pollici - Inch										
Frazioni Fractions	Decimali Decimals	0"	1"	2"	3"	4"	5"	6"	7"	8"	9"	10"
		Millimetri - Millimetres										
-	-	-	25,4000	50,8000	76,2000	101,6000	127,0000	152,4000	177,8000	203,2000	228,6000	254,0000
1/32	0,015625	0,3969	25,7969	51,1969	76,5969	101,9969	127,3969	152,7969	178,1969	203,5969	228,9969	254,3969
3/64	0,046875	1,1906	26,5906	51,9906	77,3906	102,7906	128,1906	153,5906	178,9906	204,3906	229,7906	255,1906
1/16	0,062500	1,5875	26,9875	52,3875	77,7875	103,1875	128,5875	153,9875	179,3875	204,7875	230,1875	255,5875
5/64	0,078125	1,9844	27,3844	52,7844	78,1844	103,5844	128,9844	154,3844	179,7844	205,1844	230,5844	255,9844
3/32	0,093750	2,3812	27,7812	53,1812	78,5812	103,9812	129,3812	154,7812	180,1812	205,5812	230,9812	256,3812
7/64	0,109375	2,7781	28,1781	53,5781	78,9781	104,3781	129,7781	155,1781	180,5781	205,9781	231,3781	256,7781
1/8	0,125000	3,1750	28,5750	53,9750	79,3750	104,7750	130,1750	155,5750	180,9750	206,3750	231,7750	257,1750
9/64	0,140625	3,5719	28,9719	54,3719	79,7719	105,1719	130,5719	155,9719	181,3719	206,7719	232,1719	257,5719
5/32	0,156250	3,9688	29,3688	54,7688	80,1688	105,5688	130,9688	156,3688	181,7688	207,1688	232,5688	257,9688
11/64	0,171875	4,3656	29,7656	55,1656	80,5656	105,9656	131,3656	156,7656	182,1656	207,5656	232,9656	258,3656
3/16	0,187500	4,7625	30,1625	55,5625	80,9625	106,3625	131,7625	157,1625	182,5625	207,9625	233,3625	258,7625
13/64	0,203125	5,1594	30,5594	55,9594	81,3594	106,7594	132,1594	157,5594	182,9594	208,3594	233,7594	259,1594
7/32	0,218750	5,5562	30,9562	56,3562	81,7562	107,1562	132,5562	157,9562	183,3562	208,7562	234,1562	259,5562
15/64	0,234375	5,9531	31,3531	56,7531	82,1531	107,5531	132,9531	158,3531	183,7531	209,1531	234,5531	259,9531
1/4	0,250000	6,3500	31,7500	57,1500	82,5500	107,9500	133,3500	158,7500	184,1500	209,5500	234,9500	260,3500
17/64	0,265625	6,7469	32,1469	57,5469	82,9469	108,3469	133,7469	159,1469	184,5469	209,9469	235,3469	260,7469
9/32	0,281250	7,1438	32,5438	57,9438	83,3438	108,7438	134,1438	159,5438	184,9438	210,3438	235,7438	261,1438
19/64	0,296875	7,5406	32,9406	58,3406	83,7406	109,1406	134,5406	159,9406	185,3406	210,7406	236,1406	261,5486
5/16	0,312500	7,9375	33,3375	58,7375	84,1375	109,5375	134,9375	160,3375	185,7375	211,1375	236,5375	261,9375
21/64	0,328125	8,3344	33,7344	59,1344	84,5344	109,9344	135,3344	160,7344	186,1344	211,5344	236,9344	262,3344
11/32	0,343750	8,7312	34,1312	59,5312	84,9312	110,3312	135,7312	161,1312	186,5312	211,9312	237,3312	262,7312
23/64	0,359375	9,1281	34,5281	59,9281	85,3281	110,7281	136,1281	161,5281	186,9281	212,3281	237,7281	263,1281
3/8	0,375000	9,5250	34,9250	60,3250	85,7250	111,1250	136,5250	161,9250	187,3250	212,7250	238,1250	263,5250
25/64	0,390625	9,9219	35,3219	60,7219	86,1219	111,5219	136,9219	162,3219	187,7219	213,1219	238,5219	263,9219
13/32	0,406250	10,3188	35,7188	61,1188	86,5188	111,9188	137,3188	162,7188	188,1188	213,5188	238,9188	264,3188
27/64	0,421875	10,7156	36,1151	61,5156	86,9156	112,3156	137,7156	163,1156	188,5156	213,9156	239,3156	264,7156
7/16	0,437500	11,1125	36,5125	61,9125	87,3125	112,7125	138,1125	163,5125	188,9125	214,3125	239,7125	265,1125
29/64	0,453125	11,5094	36,9094	62,3094	87,7094	113,1094	138,5094	163,9094	189,3094	214,7094	240,1094	265,5094
15/32	0,468750	11,9062	37,3062	62,7062	88,1062	113,5062	138,9062	164,3062	189,7062	215,1062	240,5062	265,9062
31/64	0,484375	12,3031	37,7031	63,1031	88,5031	113,9031	139,3031	164,7031	190,1031	215,5031	240,9031	266,3031
1/2	0,500000	12,7000	38,1000	63,5000	88,9000	114,3000	139,7000	165,1000	190,5000	215,9000	241,3000	266,7000
33/64	0,515625	13,0969	38,4969	63,8969	89,2969	114,6969	140,0969	165,4969	190,8969	216,2969	241,6969	267,0969
17/32	0,531250	13,4938	38,8938	64,2938	89,6938	115,0938	140,4938	165,8938	191,2938	216,6938	242,0938	267,4938
35/64	0,546875	13,8906	39,2906	64,6906	90,0906	115,4906	140,8906	166,2906	191,6906	217,0906	242,4906	267,8906
9/16	0,562500	14,2875	39,6875	65,0875	90,4875	115,8875	141,2875	166,6875	192,0875	217,4875	242,8875	268,2875
37/64	0,578125	14,6844	40,0844	65,4844	90,8844	116,2844	141,6844	167,0844	192,4844	217,8844	243,2844	268,6844
19/32	0,593750	15,0812	40,4812	65,8812	91,2812	116,6812	142,0812	167,4812	192,8812	218,2812	243,6812	269,0812
39/64	0,609375	15,4781	40,8781	66,2781	91,6781	117,0781	142,4781	167,8781	193,2781	218,6781	244,0781	269,4781
5/8	0,625000	15,8750	41,2750	66,6750	92,0750	117,4750	142,8750	168,2750	193,6750	219,0750	244,4750	269,8750
41/64	0,640625	16,2719	41,6719	67,0719	92,4719	117,8719	143,2719	168,6719	194,0719	219,4719	244,8719	270,2719
21/32	0,656250	16,6688	42,0688	67,4688	92,8688	118,2688	143,6688	169,0688	194,4688	219,8688	245,2688	270,6688
43/64	0,671875	17,0656	42,4656	67,8656	93,2656	118,6656	144,0659	169,4656	194,8656	220,2656	245,6656	271,0656
11/16	0,687500	17,4625	42,8625	68,2625	93,6625	119,0625	144,4625	169,8625	195,2625	220,6625	246,0625	271,4625
45/64	0,703125	17,8594	43,2594	68,6594	94,0594	119,4594	144,8594	170,2594	195,6594	221,0594	246,4594	271,8594
23/32	0,718750	18,2562	43,6562	69,0562	94,4562	119,8562	145,2562	170,6562	196,0562	221,4562	246,8562	272,2562
47/64	0,734375	18,6531	44,0531	69,4531	94,8531	120,2531	145,6531	171,0531	196,4531	221,8531	247,2531	272,6531
3/4	0,750000	19,0500	44,4500	69,8500	95,2500	120,6500	146,0500	171,4500	196,8500	222,2500	247,6500	273,0500
49/64	0,765625	19,4469	44,8469	70,2469	95,6469	121,0469	146,4469	171,8469	197,2469	222,6469	248,0469	273,4469
25/32	0,781250	19,8438	45,2438	70,6438	96,0438	121,4438	146,8438	172,2438	197,6438	223,0438	248,4438	273,8438
51/64	0,796875	20,2406	45,6406	71,0406	96,4406	121,8406	147,2406	172,6406	198,0406	223,4406	248,8406	274,2406
13/16	0,812500	20,6375	46,0375	71,4375	96,8375	122,2375	147,6375	173,0375	198,4375	223,8375	249,2375	274,6375
53/64	0,828125	21,0344	46,4344	71,8344	97,2344	122,6344	148,0344	173,4344	198,8344	224,2344	249,6344	275,0344
27/32	0,843750	21,4312	46,8312	72,2312	97,6312	123,0312	148,4312	173,8312	199,2312	224,6312	250,0312	275,4312
55/64	0,859375	21,8281	47,2281	72,6281	98,0281	123,4281	148,8281	174,2281	199,6281	225,0281	250,4281	275,8281
7/8	0,875000	22,2250	47,6250	73,0250	98,4250	123,8250	149,2250	174,6250	200,0250	225,4250	250,8250	276,2250
57/64	0,890625	22,6219	48,0219	73,4219	98,8219	124,2219	149,6219	175,0219	200,4219	225,8219	251,2219	276,6219
29/32	0,906250	23,0188	48,4188	73,8188	99,2188	124,6188	150,0188	175,4188	200,8188	226,2188	251,6188	277,0188
59/64	0,921875	23,4156	48,8156	74,2156	99,6156	125,0156	150,4156	175,8156	201,2156	226,6156	252,0156	277,4156
15/16	0,937500	23,8125	49,2125	74,6125	100,0125	125,4125	150,8125	176,2125	201,6125	227,0125	252,4125	277,8125
61/64	0,953125	24,2094	49,6094	75,0094	100,4094	125,8094	151,2094	176,6094	202,0094	227,4094	252,8094	278,2094
31/32	0,968759	24,6062	50,0062	75,4062	100,8062	126,2062	151,6062	177,0062	202,4062	227,8062	253,2062	278,6062
63/64	0,984375	25,0031	50,4031	75,8031	101,2031	126,6031	152,0031	177,4031	202,8031	228,2031	253,6031	279,0031



## 10. TABELLA D'INTERCAMBIABILITÀ

## 10. INTERCHANGEABILITY TABLE

Tipologia Type	EUROPE				ASIA	
	KDF® Italy	INA/FAG Germany	RHP United Kingdom	SKF Sweden	ASAHI Japan	FYH Japan
Supporti ritri Pillow blocks	UCP 2.., UKP 2.., HCP 2..	RASE, RASES, PASE	NP	SY, SYP, SYJ..TF	UCP, UKP 200	UCP, UKP, NAP 200
	UCLP 2..	-	SL	SYH-X	-	SL 200
	UCP X..	-	MP	-	UCP X00	UCP X00
	UCPH 2.., UKPH 2..	-	-	-	UCPH 200	UCPH 200
	UCPA 2.., UKPA 2..	SHE	-	SYF	UCPA 200	UCPA 200
UP..	-	-	-	UP 00	-	
Supporti a flangia Flange units	UCF 2.., UKF 2.., HCF 2..	RCJ, RCJS, PCF	SF, SLF	FY, FYP, FY-X	UCF, UKF 200	UFC 200 SLF 200
	UCF X..	-	MSF	-	UCF X00	UCF X00
	UCFC 2.., UKFC 2.., HCF 2..	-	-	FYC	UCFC, UKFC 200	UCFC 200
	UCFC X..	-	MFC	-	UCFC X00	UCFC X00
	UCFL 2.., UKFL 2.., HCF 2..	RCJT, RCJTS, PCFT	SFT	FYTB	UCFL 200	UCFL 200
	UCFL X..	-	MSFT	-	UCFL X00	UCFL X00
	UFL..	-	-	-	UFL 00	-
	SAFD 2.. - SBF 2..	FLCTE / FLCTEY	-	-	-	-
	SALF 2.. - SBLF 2..	-	-	-	-	ALF-BLF 2
	UCFA 2.., UKFA 2..	SFT	-	-	UCFA 200	UCFA 200
UCFB 2.., UKFB 2..	-	-	-	UCFK 200	UCFB 200	
Supporti scorrevoli Take-up units	UCT 2.., UKT 2.., HCT 2..	PTUE, RTUES	-	-	UCT 200	UCT 200
	UCT X..	-	-	-	UCT X00	UCT X00
Piastra tenditore Stretch-skid	UCT..	-	-	-	WA	UCTH
Supporti a cartuccia Cylindrical cartridge units	UCC 2.., UKC 2.., HCC 2..	-	-	TU	UCC 200	UCC 200
	UCC X..	-	-	-	UCC X00	UCC X00
Supporti pensili Hanger units	UCECH 2.., UKECH 2..	-	SCHB	-	UCECH 200	UCHA 200
Supporti in lamiera stampata Pressed steel bearing units	BPP..	PB	LPB	SP	BPP	SBPP 200 F
	BPF..	RA, RR	SLFE	F	BPF	SBPF 200
	BPFL..	RAT, RRT	SLFL	FT	BPFL	SBPFL 200
	BPFT..	RATR, RRTR	-	-	BPFT	-
Supporti per agricoltura Agricultural units	ST	-	-	-	-	-
Supporti ritri in due metà Bearing housing	SNG 500	-	-	SNH 500	-	-
	SNG 600	-	-	SNH 600	-	-
	SN 500	-	-	-	-	-
	SN 200	-	-	SNH 200	-	-
	SN 300	-	-	SNH 300	-	-
	SD 3000	-	-	-	-	-
	SD 3100	-	-	SD 3100	-	-
	UCP 2..	PASE, RASEY	-	-	-	-
UCF 2..	PCJ, RCJY	-	-	-	-	
UCFL 2..	PCJT, RCJTY	-	-	-	-	
UCECH 2..	-	-	-	-	-	
UCPA 2..	-	-	-	-	-	
UCFB 2..	-	-	-	-	-	
Cuscinetti per supporti Bearings for units	UC 2..	KRRB	1000 G	YAR	UC 200	UC 200
	HC 2..	GE..KRRB	-	YEL 200	UG 200	NA 200
	UCX..	-	-	-	UCX 00	UCX 00
	UC 3..	-	-	YEL 300	UC 300	UC 300
	UK 2..	GSE..KRRB	1000G	YSA 200	UK 200	UK 200
	UK 3..	-	-	YSA 300	UK 300	UK 300
	SER 2..	-	-	-	SER 200	ER 200
	SA 2..	RAE..NPPB	12..EC	YET 200	SA 200	SA 200
	SB 2..	AY..NPPB	-	YAT 200	SB 200	SB 200
	RB 2..	-	-	-	-	RB 200
	SC 2..	2..NPPB	-	-	-	SC 200
	U0..	-	-	-	-	-

La tabella sopra riportata può essere utilizzata quale riferimento generale per l'intercambiabilità dei supporti e cuscinetti KDF® rispetto ad altre marche. Si raccomanda sempre di verificare con attenzione le dimensioni dei prodotti KDF® rispetto agli stessi articoli di altre marche; alcuni hanno identiche dimensioni, mentre altri possono avere dimensioni diverse. I cuscinetti della serie pesante non sono stati citati in questa tabella, ma sono comunque disponibili per le serie: UCP - UCF - UCFS - UCFL - UCT

ASIA				AMERICA		
KOYO Japan	NACHI Japan	NSK Japan	NTN Japan	FAFNIR U.S.A.	LINK-BELT U.S.A.	SEAL-MASTER U.S.A.
UCP, UKP 200, GAP 1100B	UCP, UKP+H, UGP, BP 200	UCP, UKP, EWP 200	UCP, UK, UEL 200	RAS, LAS	P3-Y200N	NP
SLP 200	UCLR, FGA 200	UCPLL, EWPLL 200	UCPL 200	RAK, LAK	PL3-Y200N	S-500-M
UCP X00	UCP, UKP+H X00	UCP X00	UCP X00	RAKH, LAKH	-	MP
-	-	UCPH 200	UCPH 200	-	-	-
UCPA 200 UKPA 200	UCPA 200	UCPA 200	UCUP 200	-	-	-
-	-	UBLP 200	UP 00	-	-	-
UCF 200 GFF 1100	UCF, UKF+H, UGF, BF, UCLF 200	UCF, EWFH 200	UCF 200	RCJ, LCJ	F3-Y200N	SF
UCF X00	UCF, UKF+H X00	UCF X00	UCF X00	RCJO, LCJO	-	MSF
UCFC 200	UCFC, UKFC+H, UGFC, BCF 200	UCFC 200	UCFC 200	-	-	-
UCFC X00	UCF, UKFC+H X00	UCFC X00	UCFC X00	RFC	FC3-Y200N	MFC
UCFL 200 UCFL 1100	UCFL, UKFL+H, UGFL, BFL, UCFT 200	UCFL, EWFLH 200	UCFL 200	FCJT, LCJT	FX3-Y200N	SFT
UCFL X00	UCFL, UKFL+H X00	UCFL X00	UCFL X00	-	-	MSFT
-	-	UBLF 200	UFL 00	-	-	-
-	-	-	ASFD 2	-	-	-
-	-	-	-	-	-	-
UCAF 200 UKAF 200	-	UCFA 200	UCFA 200	-	-	-
UCBF 200	UCFK 200	UCFK 200	UCFH 200	-	-	-
UCT 200	UCT, UKT+H, UGT, BT 200	UCT 200	UCT 200	-	-	-
UCT X00	UCT, UKT+H X00	UCT X00	UCT X00	-	-	-
LV-HT	-	WB	UCT	-	-	-
UCC 200	UCC, UKC+H, UGC, BC 200	UCC 200	UCC 200	-	-	-
UCC X00	UCC, UKC+H X00	UCC X00	UCC X00	-	-	-
SCHB 200	ECECH 200	UCEH 200	UCHB 200	-	-	SEHB
SP	BPP	UBPP 200	ASPP 200	PB	-	SSP
PF	BPF	UBPF 200	ASPF 200	RE, RR	MSC1	SSF
PTF	BPFL	UBPFL 200	ASPFL 200	RAT, RRT	MST	SSFT
PTFR	BPFT	UBPFT 200	-	RATR, RRTR	MSTR	TSSF
-	-	-	-	-	-	-
-	-	-	-	-	-	-
-	-	-	-	-	-	-
-	-	-	-	-	-	-
-	-	-	-	-	-	-
-	-	-	-	-	-	-
-	-	-	-	-	-	-
-	-	-	-	-	-	-
-	-	-	-	-	-	-
-	-	-	-	-	-	-
-	-	-	-	-	-	-
-	-	-	-	-	-	-
-	-	-	-	-	-	-
-	-	-	-	-	-	-
-	-	-	-	-	-	-
-	-	-	-	-	-	-
UC 200	UC (UCW) 200	UC 200	UC 200	GC1100KRRB	YG 200 N	2-00
-	-	EW 200	UEL 200	G1100KRBB	-	-
UCX 00	UCX 00	UCX 00	UCX 00	GN-KRRB	U300D	3-00
UC 300	UC 300	UC 300	UC 300	-	-	-
UK 200	UK 200	UK 200	UK 200	G-KLLB	YG 200 N	2-00
UK 300	UK 300	UK 300	UK 300	-	-	-
-	SER 200	-	UCS 200	GC-KRRG-2	-	ER
-	KH 200 AE	EN 200	AEL 200	RA..RRB	-	L-00
PB	B	UB 200	AS 200	YA..RRB	-	-
-	-	UR 200	-	-	-	-
CB	-	CS 2.. DDU	CS 2.. LLU	-	-	-
-	-	-	-	-	-	-

The above table should be used as a cross reference for **KDF®** and other manufacturers of self-aligning bearing units. Please note that some dimensions of the **KDF®** brand may differ slightly from those of other manufacturers. Heavier duty Pillow Blocks have not been included in this cross reference table. Sizes available are: UCP - UCF - UCFS - UCFL - UCT.

## 11. TIPOLOGIA DEI SUPPORTI E CUSCINETTI KDF®

## 11. KDF® BEARING UNITS AND BEARINGS TYPE

Supporto Housing	Cuscinetto - Bearing					
	UC2.. UC3.. UCX..	UK2.. UK3.. UKX..	HC2..	SA2..	SB-RB2..	UO..
P	UCP2.. - UCP3.. UCLP2.. - UCPX..	UKP2.. - UKP3.. UKPX..	HCP2..	SAP	SBP	-
F	UCF2.. - UCF3.. UCFS3.. - UCFX..	UKF2.. - UKF3.. UKFX..	HCF2..	SAF	SBF	-
FC	UCFC2.. - UCFCX..	UKFC2.. - UKFCX..	HCFC2..	SAFC	SBFC	-
FL	UCFL2.. - UCFL3.. UCFLX..	UKFL2.. - UKFL3.. UKFLX..	HCFL2..	SAFL	SBFL	-
T	UCT2.. - UCT3.. UCTX..	UKT2.. - UKT3.. UKTX..	HCT2..	SAT	SBT	-
C	UCC2.. - UCC3.. UCCX..	UKC2.. - UKC3.. UKCX..	HCC2..	SAC	SBC	-
PH	UCPH2..	UKPH2..	HCPH2..	SAPH	SBPH	-
PA	UCPA2..	UKPA2..	HCPA2..	SAPA	SBPA	-
FA	UCFA2..	UKFA2..	HCFA2..	SAFA	SBFA	-
FB	UCFB2..	UKFB2..	HCFB2..	SAFB	SBFB	-
ECH	UCECH2..	UKECH2..	HCECH2..	SAECH	SBECH	-
LP Alluminio Aluminium	-	-	HCLP2..	SALP	-	UP
LF Alluminio Aluminium	-	-	HCLF2..	SALF2..	-	UFL
FD	-	-	HCFD2..	SAFD2..	SBFD2..	-
LF	-	-	HCLF2..	SALF2..	SBLF2..	-
ST	Supporti agricoli (su richiesta disponibili misure in pollici) - <i>Agricultural bearing units (inches size are available under request)</i>					
PP	BPP..	-	-	BPP-SA2..	BPP-SB2..	-
PF	BPF..	-	-	BPF-SA2..	BPF-SB2..	-
PFL	BPFL..	-	-	BPFL-SA2..	BPFL-SB2..	-
FT	BPFT..	-	-	BPFT-SA2..	BPFT-SB2..	-
SNG SN-SD	Supporti ritti in due metà - <i>Bearing Housings</i>					
P Plastica Plastic	UCP2..	con cuscinetto UC inox ed in plastica - <i>with plastic or stainless steel UC bearing</i>				
F Plastica Plastic	UCF2..	con cuscinetto UC inox ed in plastica - <i>with plastic or stainless steel UC bearing</i>				
FL Plastica Plastic	UCFL2..	con cuscinetto UC inox ed in plastica - <i>with plastic or stainless steel UC bearing</i>				
T Plastica Plastic	UCT2..	con cuscinetto UC inox ed in plastica - <i>with plastic or stainless steel UC bearing</i>				
ECH Plastica Plastic	UCECH2..	con cuscinetto UC inox ed in plastica - <i>with plastic or stainless steel UC bearing</i>				
PA Plastica Plastic	UCPA2..	con cuscinetto UC inox ed in plastica - <i>with plastic or stainless steel UC bearing</i>				
FB Plastica Plastic	UCFB2..	con cuscinetto UC inox ed in plastica - <i>with plastic or stainless steel UC bearing</i>				



Foto prodotto Product photo	Tipo Type	Dimensioni Dimensions	Pagina Page
	Supporti ritti (UCP2..) (UCP2..) Pillow block units	12 > 90	1
	Supporti ritti (HCP2..) (HCP2..) Pillow block units	20 > 75	2
	Supporti ritti - Serie ribassata (UCLP2..) (UCLP2..) Pillow block units - Height reduced series	12 > 60	3
	Supporti ritti con bussola montata (UKP2..) (UKP2..) Pillow block units with adapter sleeve mounted	20 > 80	4
	Supporti ritti (UCPX..) (UCPX..) Pillow block units	25 > 100	5
	Supporti ritti (UCP3..) (UCP3..) Pillow block units	25 > 95	6
	Supporti a flangia quadra (UCF2..) (UCF2..) Square flange units	12 > 90	7
	Supporti a flangia quadra (HCF2..) (HCF2..) Square flange units	20 > 75	8
	Supporti a flangia quadra con bussola montata (UKF2..) (UKF2..) Square flange units with adapter sleeve mounted	20 > 80	9
	Supporti a flangia quadra (UCFX2..) (UCFX2..) Square flange units	25 > 85	10
	Supporti a flangia quadra (UCF3..) (UCF3..) Square flange units	25 > 100	11
	Supporti a flangia quadra con collare di centaggio (UCFS3..) (UCFS3..) Square flange units with eccentric collar locking	25 > 100	12
	Supporti a flangia tonda (UCFC2..) (UCFC2..) Flange cartridge units	12 > 90	13
	Supporti a flangia tonda (HCFC2..) (HCFC2..) Flange cartridge units	12 > 75	14
	Supporti a flangia tonda con bussola montata (UKFC2..) (UKFC2..) Flange cartridge units with adapter sleeve mounted	20 > 80	15
	Supporti a flangia tonda (UCFCX..) (UCFCX..) Flange cartridge units	25 > 100	16
	Supporti a flangia ovale (UCFL2..) (UCFL2..) Oval flange units	12 > 90	17
	Supporti a flangia ovale (HCFL2..) (HCFL2..) Oval flange units	20 > 75	18
	Supporti a flangia ovale con bussola montata (UKFL2..) (UKFL2..) Oval flange units with adapter sleeve mounted	20 > 80	19
	Supporti a flangia ovale (UCFLX..) (UCFLX..) Oval flange units	25 > 50	20
	Supporti a flangia ovale (UCFL3..) (UCFL3..) Oval flange units	25 > 100	21

Foto prodotto Product photo	Tipo Type	Dimensioni Dimensions	Pagina Page
	Supporti scorrevoli (UCT2..) (UCT2..) Take-up units	12 > 85	22
	Supporti scorrevoli (HCT2..) (HCT2..) Take-up units	20 > 75	23
	Supporti scorrevoli con bussola montata (UKT2..) (UKT2..) Take-up units with adapter sleeve mounted	20 > 75	24
	Supporti scorrevoli (UCTX..) (UCTX..) Take-up units	25 > 85	25
	Supporti scorrevoli (UCT3..) (UCT3..) Take-up units	25 > 100	26
	Piastra con tenditore per UCT (UCT2.. - UCTX..) (UCT2.. - UCTX..) Stretch-skid for UCT	20 > 85	27
	Supporti a cartuccia (UCC2..) (UCC2..) Cylindrical cartridge units	12 > 65	28
	Supporti a cartuccia (HCC2..) (HCC2..) Cylindrical cartridge units	20 > 60	29
	Supporti a cartuccia con bussola montata (UKC2..) (UKC2..) Cylindrical cartridge units with adapter sleeve mounted	20 > 60	30
	Supporti a cartuccia (UCCX..) (UCCX..) Cylindrical cartridge units	25 > 60	31
	Supporti ritti con piedistallo (UCPH2..) (UCPH2..) Pedestal pillow blocks	12 > 80	32
	Supporti ritti con piedistallo con bussola montata (UKPH2..) (UKPH2..) Pedestal pillow blocks with adapter sleeve mounted	20 > 45	33
	Supporti ritti senza piedi (UCPA2..) (UCPA2..) Tapped base pillow blocks	12 > 65	34
	Supporti ritti senza piedi con bussola montata (UKPA2..) (UKPA2..) Tapped base pillow blocks with adapter sleeve mounted	20 > 45	35
	Supporti a flangia orientabili (UCFA2..) (UCFA2..) Adjustable flange units	12 > 65	36
	Supporti a flangia orientabili con bussola montata (UKFA2..) (UKFA2..) Adjustable flange units with adapter sleeve mounted	20 > 45	37
	Supporti a flangia (UCFB2..) (UCFB2..) Flange bracket units	12 > 65	38
	Supporti a flangia con bussola montata (UKFB2..) (UKFB2..) Flange bracket units with adapter sleeve mounted	20 > 45	39
	Supporti pensili (UCECH2..) (UCECH2..) Hanger bearing units	12 > 65	40
	Supporti pensili con bussola montata (UKECH2..) (UKECH2..) Hanger bearing units with adapter sleeve mounted	20 > 55	41
	Supporti ritti - serie leggera (UP..) (UP..) Light duty - Pillow block units	12 > 35	42

























Foto prodotto Product photo	Tipo Type	Dimensioni Dimensions	Pagina Page
	Supporti a flangia ovale - serie leggera (UFL..) (UFL..) Light duty - Oval flange units	12 > 35	42
	Supporti a flangia ovale (SAFD2..) (SAFD2..) Oval flange units	12 > 35	43
	Supporti a flangia ovale (SBFD2..) (SBFD2..) Oval flange units	12 > 35	43
	Supporti a flangia ovale (SALF2..) (SALF2..) Oval flange units	12 > 35	44
	Supporti a flangia ovale (SBFL2..) (SBLF2..) Oval flange units	12 > 35	44
	Supporti agricoli (ST) (ST) Agricultural bearing units	38,860 > 55,562 32,0 > 43,1	45
	Supporti ritti in lamiera stampata (BPP-SA2.. - BPP-SB2..) (BPP-SA2.. - BPP-SB2..) Pressed steel pillow blocks	12 > 35	46
	Supporti a flangia tonda in lamiera stampata (BPF-SA2.. - BPF-SB2..) (BPF-SA2.. - BPF-SB2..) Pressed steel flange units	12 > 40	47
	Supporti a flangia ovale in lamiera stampata (BPFL-SA2.. - BPFL-SB2..) (BPFL-SA2.. - BPFL-SB2..) Pressed steel oval flange units	12 > 40	48
	Supporti a flangia triangolare in lamiera stampata (BPFT-SA2.. - BPFT-SB2..) (BPFT-SA2.. - BPFT-SB2..) Pressed steel triangular flange units	12 > 35	49
	Cuscinetti a sfere sigillati con grani di bloccaggio (UC2..) (UC2..) Sealed ball bearings with set screws	12 > 90	50
	Cuscinetti a sfere sigillati con anello eccentrico di fissaggio (HC2..) (HC2..) Sealed ball bearings with eccentric collar locking	20 > 75	51
	Cuscinetti a sfere sigillati con grani di bloccaggio (UCX..) (UCX..) Sealed ball bearings with set screws	25 > 100	52
	Cuscinetti a sfere sigillati con grani di bloccaggio - serie pesante (UC3..) (UC3..) Sealed ball bearings with set screws - heavy series	25 > 100	53
	Cuscinetti a sfere sigillati con bussola montata (UK2..) (UK2..) Sealed ball bearings with adapter sleeve mounted	25 > 90	54
	Cuscinetti a sfere sigillati con bussola montata - serie media (UKX..) (UKX..) Sealed ball bearings with adapter sleeve mounted - medium series	25 > 90	55
	Cuscinetti a sfere sigillati con bussola montata - serie pesante (UK3..) (UK3..) Sealed ball bearings with adapter sleeve mounted - heavy series	25 > 90	56
	Cuscinetti a sfere sigillati con anello di fissaggio (SER2..) (SER2..) Sealed ball bearings with locating snap ring	20 > 60	57
	Cuscinetti a sfere sigillati con anello eccentrico di fissaggio (SA2..) (SA2..) Sealed ball bearings with eccentric collar locking	12 > 60	58
	Cuscinetti a sfere sigillati con grani di bloccaggio (SB-RB2..) (SB-RB2..) Sealed ball bearings with set screws	12 > 60	59
	Cuscinetti a sfere sigillati (SC2..) (SC2..) Sealed ball bearings	10 > 60	60

Foto prodotto Product photo	Tipo Type	Dimensioni Dimensions	Pagina Page
	Cuscinetti con grani (U0..) (U0..) Bearings with set screws	10 > 30	60
	Bussole di trazione (H23..) (H23..) Adapter sleeves	20 > 125	61
	Supporti ritti in due metà (SNG 500) (SNG 500) Bearing housings	30 > 140	68
	Supporti ritti in due metà (SNG 600) (SNG 600) Bearing housings	30 > 90	70
	Supporti ritti in due metà (SN 500) (SN 500) Bearing housings	25 > 140	72
	Supporti ritti in due metà (SN 200) (SN 200) Bearing housings	35 > 160	74
	Supporti ritti in due metà (SN 300) (SN 300) Bearing housings	35 > 160	76
	Supporti ritti in due metà (SD 3000) (SD 3000) Bearing housings	150 > 360	78
	Supporti ritti in due metà (SD 3100) (SD 3100) Bearing housings	150 > 380	80
	Supporti ritti in plastica (UCP2..) (UCP2..) Plastic pillow block units	12 > 50	85
	Supporti a flangia quadra in plastica (UCF2..) (UCF2..) Plastic square flange units	12 > 50	86
	Supporti a flangia ovale in plastica (UCFL2..) (UCFL2..) Plastic oval flange units	12 > 50	87
	Supporti scorrevoli in plastica (UCT2..) (UCT2..) Plastic take-up units	12 > 50	88
	Supporti pensili in plastica (UCECH2..) (UCECH2..) Plastic hanger bearing units	12 > 50	89
	Supporti ritti senza piedi in plastica (UCPA2..) (UCPA2..) Plastic tapped base pillow blocks	12 > 50	90
	Supporti a flangia in plastica (UCFB2..) (UCFB2..) Plastic flange bracket units	12 > 35	91
	Coperchi Covers	12 > 40	92
	Cuscinetti a sfere in materiali polimerici (UC2..) (UC2..) Polymeric ball bearings	10 > 40	93
	Cuscinetti a sfere in materiali polimerici sigillati pre-lubrificati 2RS (SA2..) (SA2..) Pre-greased sealed polymeric ball bearings 2RS	20 > 50	94
	Cuscinetti a sfere in materiali polimerici sigillati pre-lubrificati 2RS (SB2..) (SB2..) Pre-greased sealed polymeric ball bearings 2RS	20 > 50	95

# KDF®







# SUPPORTI RITTI PILLOW BLOCK UNITS



## UCP2 Serie normale Normal Series

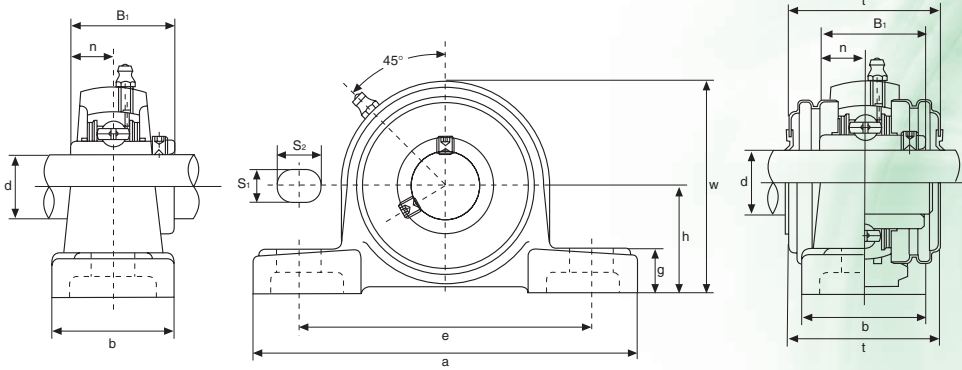

Tipo Type	Dimensioni mm/pollici Dimensions mm/inch											Bull. fiss. Bolt Size mm/inch	Coefficienti di carico (N) Load ratings (N)		Cuscinetto Bearing	Supporto Housing	Peso Weight (kg)	
	d	h	a	e	b	S <sub>1</sub>	S <sub>2</sub>	g	w	t	B <sub>1</sub>		n	Dinamico C Dynamic C				Statico C <sub>0</sub> Static C <sub>0</sub>
UCP201 UCP201-8	12 3/4	30,2 1 1/16	127 5	95 3 3/4	38 1 1/2	13 1/2	19 3/4	14 9/16	62 2 7/16	44,5 1 3/4	31 1,2205	12,7 0,500	M10 3/8	12 200	6 350	UC201 UC201-8	P203	0,69 0,69
UCP202 UCP202-9 UCP202-10	15 9/16 5/8	30,2 1 1/16	127 5	95 3 3/4	38 1 1/2	13 1/2	19 3/4	14 9/16	62 2 7/16	44,5 1 3/4	31 1,2205	12,7 0,500	M10 3/8	12 200	6 350	UC202 UC202-9 UC202-10	P203	0,69 0,69 0,69
UCP203 UCP203-11	17 1 1/16	30,2 1 1/16	127 5	95 3 3/4	38 1 1/2	13 1/2	19 3/4	14 9/16	62 2 7/16	44,5 1 3/4	31 1,2205	12,7 0,500	M10 3/8	12 200	6 350	UC203 UC203-11	P203	0,68 0,67
UCP204 UCP204-12	20 3/4	33,3 1 1/16	127 5	95 3 3/4	38 1 1/2	13 1/2	19 3/4	14 9/16	65 2 9/16	44,5 1 3/4	31 1,2205	12,7 0,500	M10 3/8	12 200	6 350	UC204 UC204-12	P204	0,66 0,66
UCP205 UCP205-13 UCP205-14 UCP205-15 UCP205-16	25 1 3/16 7/8 15/16 1	36,5 1 7/16	140 5 1/2	105 4 1/8	38 1 1/2	13 1/2	19 3/4	15 19/32	71 2 25/32	48 1 57/64	34,1 1,3425	14,3 0,563	M10 3/8	13 300	7 500	UC205 UC205-13 UC205-14 UC205-15 UC205-16	P205	0,81 0,85 0,83 0,82 0,81
UCP206 UCP206-17 UCP206-18 UCP206-19 UCP206-20	30 1 1/4 1 1/8 1 3/8 1 1/4	42,9 1 1/16	165 6 1/2	121 4 3/4	48 1 7/8	17 4 3/4	20 2 5/32	17 2 1/32	84 3 3/16	53 2 5/64	38,1 1,5000	15,9 0,626	M14 1/2	18 600	10 800	UC206 UC206-17 UC206-18 UC206-19 UC206-20	P206	1,24 1,27 1,26 1,24 1,23
UCP207 UCP207-20 UCP207-21 UCP207-22 UCP207-23	35 1 1/4 1 3/16 1 3/8 1 1/16	47,6 1 7/8	167 6 5/16	127 5	48 1 7/8	17 4 3/4	20 2 5/32	18 4 5/64	93 3 21/32	59,5 2 11/32	42,9 1,6890	17,5 0,689	M14 1/2	24 500	14 600	UC207 UC207-20 UC207-21 UC207-22 UC207-23	P207	1,58 1,64 1,61 1,58 1,55
UCP208 UCP208-24 UCP208-25	40 1 1/2 1 3/8	49,2 1 15/16	184 7 1/4	137 5 13/32	54 2 1/8	17 4 3/4	20 2 5/32	18 4 5/64	100 3 15/16	69 2 23/32	49,2 1,9370	19 0,748	M14 1/2	27 700	17 000	UC208 UC208-24 UC208-25	P208	1,89 1,93 1,90
UCP209 UCP209-26 UCP209-27 UCP209-28	45 1 5/8 1 11/16 1 3/4	54,0 2 1/8	190 7 5/32	146 5 3/4	54 2 1/8	17 4 3/4	20 2 5/32	20 2 5/32	106 4 1 1/64	69 2 23/32	49,2 1,9370	19 0,748	M14 1/2	31 000	19 500	UC209 UC209-26 UC209-27 UC209-28	P209	2,14 2,24 2,20 2,14
UCP210 UCP210-29 UCP210-30 UCP210-31 UCP210-32	50 1 13/16 1 7/8 1 15/16 2	57,2 2 1/4	206 8 1/8	159 6 3/4	60 2 3/8	20 2 5/32	23 2 9/32	21 5 3/64	113 4 29/64	74,5 2 15/16	51,6 2,0315	19 0,748	M16 5/8	33 500	22 500	UC210 UC210-29 UC210-30 UC210-31 UC210-32	P210	2,66 2,78 2,73 2,68 2,64
UCP211 UCP211-32 UCP211-33 UCP211-34 UCP211-35	55 2 2 1/16 5/8 2 3/16	63,5 2 1/2	219 8 5/8	171 6 7/64	60 2 3/8	20 2 5/32	23 2 9/32	23 2 9/32	125 4 59/64	76 3	55,6 2,1890	22,2 0,874	M16 5/8	41 500	28 000	UC211 UC211-32 UC211-33 UC211-34 UC211-35	P211	3,31 3,46 3,40 3,35 3,29
UCP212 UCP212-36 UCP212-37 UCP212-38 UCP212-39	60 2 1/4 2 1/8 2 3/8 2 1/16	69,8 2 3/4	241 9 1/2	184 7 1/4	70 2 3/4	20 2 5/32	23 2 9/32	25 6 3/64	138 5 7/16	89 3 1/2	65,1 2,5630	25,4 1,000	M16 5/8	50 000	34 500	UC212 UC212-36 UC212-37 UC212-38 UC212-39	P212	4,90 5,03 4,95 4,88 1,81
UCP213 UCP213-40 UCP213-41	65 2 1/2 2 5/16	76,2 3	265 10 7/16	203 8	70 2 3/4	25 6 3/64	28 1 3/32	27 1 1/16	150 5 29/32	89 3 1/2	65,1 2,5630	25,4 1,000	M20 3/4	54 700	38 000	UC213 UC213-40 UC213-41	P213	5,15 5,24 5,15
UCP214 UCP214-42 UCP214-43 UCP214-44	70 2 5/8 2 1 1/16 2 3/4	79,4 3 1/8	266 10 5/32	210 8 17/64	72 2 27/32	25 6 3/64	28 1 3/32	27 1 1/16	156 6 9/64	- 2,9370	74,6 1,189	30,2 1,189	M20 3/4	59 000	42 000	UC214 UC214-42 UC214-43 UC214-44	P214	6,20 6,41 6,31 6,21
UCP215 UCP215-45 UCP215-46 UCP215-47 UCP215-48	75 2 13/16 2 7/8 2 15/16 3	82,6 3 1/4	275 10 59/64	217 8 35/64	74 2 29/32	25 6 3/64	28 1 3/32	28 1 3/32	162 6 3/8	- 3,0630	77,8 1,311	33,3 1,311	M20 3/4	63 000	47 000	UC215 UC215-45 UC215-46 UC215-47 UC215-48	P215	7,16 7,41 7,30 7,19 7,07
UCP216 UCP216-49 UCP216-50 UCP216-51	80 3 1/16 3 1/8 3 3/16	88,9 3 1/2	292 11 1/2	232 9 1/8	78 3 1/16	25 6 3/64	28 1 3/32	30 1 3/16	174 6 27/32	- 3,2520	82,6 1,311	33,3 1,311	M20 3/4	69 000	51 000	UC216 UC216-49 UC216-50 UC216-51	P216	8,10 8,28 8,15 8,02
UCP217 UCP217-52 UCP217-53 UCP217-55	85 3 1/4 3 3/16 3 7/16	95,2 3 3/4	310 12 13/64	247 9 23/32	83 3 17/64	25 6 3/64	28 1 3/32	32 1 1/4	185 7 9/32	- 3,3740	85,7 1,343	34,1 1,343	M20 3/4	80 000	61 000	UC217 UC217-52 UC217-53 UC217-55	P217	9,81 10,03 9,89 9,60
UCP218 UCP218-56	90 3 1/2	101,6 4	327 12 7/8	262 10 9/16	88 3 13/32	27 1 1/16	30 1 1/16	33 1 19/64	198 7 5/64	- 3,7795	96 1,5630	39,7 1,5630	M22 7/8	91 200	68 000	UC218 UC218-56	P218	11,96 12,07

Disponibile in acciaio inox Supporto: AISI 304 - Cuscinetto: AISI 440C  
Disponibile su richiesta con cuscinetto SA (SAP..)

Available stainless steel Housing: AISI 304 - Bearing: AISI 440C  
Available under request with SA bearing (SAP..)

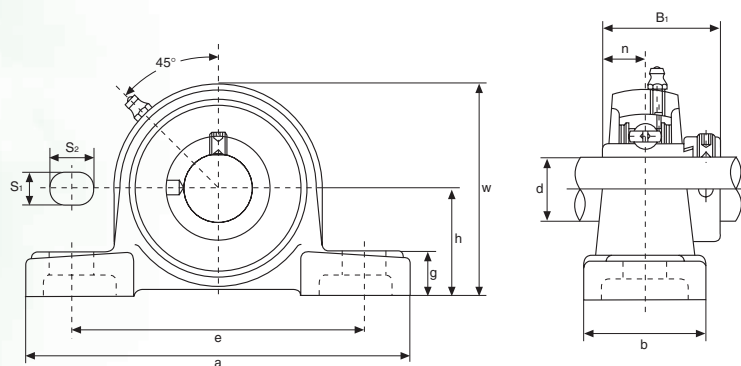

Tipo Type	Dimensioni mm/pollici Dimensions mm/inch											Bull. fiss. Bolt Size mm/inch	Coefficienti di carico (N) Load ratings (N)		Cuscinetto Bearing	Supporto Housing	Peso Weight (kg)
	d	h	a	e	b	S <sub>1</sub>	S <sub>2</sub>	g	w	B <sub>1</sub>	n		Dinamico C Dynamic C	Statico C <sub>0</sub> Static C <sub>0</sub>			
HCP204 HCP204-12	20 ¾	33,3 1 ¼	127 5	95 3 ¾	38 1 ½	13 ½	19 ¾	14 ⅞	65 2 ⅞	43,7 1,720	17,1 0,673	M10 ¾	12 200	6 350	HC204 HC204-12	P204	0,73 0,73
HCP205 HCP205-13 HCP205-14 HCP205-15 HCP205-16	25 1 ⅞ ⅞ 1 ⅞ 1	36,5 1 ⅞	140 5 ½	105 4 ⅞	38 1 ½	13 ½	19 ¾	15 ⅞	71 2 ⅞	44,4 1,748	17,5 0,689	M10 ¾	13 300	7 500	HC205 HC205-13 HC205-14 HC205-15 HC205-16	P205	0,88 0,93 0,92 0,90 0,88
HCP206 HCP206-17 HCP206-18 HCP206-19 HCP206-20	30 1 ⅞ ⅞ 1 ⅞ 1 ¼	42,9 1 ⅞	165 6 ½	121 4 ¾	48 1 ⅞	17 ⅞	20 ⅞	17 ⅞	84 3 ⅞	48,4 1,906	18,3 0,720	M14 ½	18 600	10 800	HC206 HC206-17 HC206-18 HC206-19 HC206-20	P206	1,37 1,42 1,39 1,37 1,34
HCP207 HCP207-20 HCP207-21 HCP207-22 HCP207-23	35 1 ¼ 1 ⅞ 1 ⅞ 1 ⅞	47,6 1 ⅞	167 6 ⅞	127 5	48 1 ⅞	17 ⅞	20 ⅞	18 ⅞	93 3 ⅞	51,1 2,012	18,8 0,740	M14 ½	24 500	14 600	HC207 HC207-20 HC207-21 HC207-22 HC207-23	P207	1,70 1,77 1,73 1,70 1,67
HCP208 HCP208-24 HCP208-25	40 1 ½ 1 ⅞	49,2 1 ⅞	184 7 ¼	137 5 ⅞	54 2 ⅞	17 ⅞	20 ⅞	18 ⅞	100 3 ⅞	56,3 2,217	21,4 0,843	M14 ½	27 700	17 000	HC208 HC208-24 HC208-25	P208	2,04 2,09 2,05
HCP209 HCP209-26 HCP209-27 HCP209-28	45 1 ⅞ 1 ⅞ 1 ¼	54,0 2 ⅞	190 7 ⅞	146 5 ¾	54 2 ⅞	17 ⅞	20 ⅞	20 ⅞	106 4 ⅞	56,3 2,217	21,4 0,843	M14 ½	31 000	19 500	HC209 HC209-26 HC209-27 HC209-28	P209	2,31 2,42 2,37 2,33
HCP210 HCP210-29 HCP210-30 HCP210-31 HCP210-32	50 1 ⅞ 1 ⅞ 1 ⅞ 2	57,2 2 ¼	206 8 ⅞	159 6 ¼	60 2 ⅞	20 ⅞	23 ⅞	21 ⅞	113 4 ⅞	62,7 2,469	24,6 0,969	M16 ⅝	33 500	22 500	HC210 HC210-29 HC210-30 HC210-31 HC210-32	P210	2,85 3,00 2,94 2,88 2,82
HCP211 HCP211-32 HCP211-33 HCP211-34 HCP211-35	55 2 2 ⅞ 2 ⅞ 2 ⅞	63,5 2 ½	219 8 ⅞	171 6 ⅞	60 2 ⅞	20 ⅞	23 ⅞	23 ⅞	125 4 ⅞	71,4 2,811	27,8 1,094	M16 ⅝	41 500	28 000	HC211 HC211-32 HC211-33 HC211-34 HC211-35	P211	3,52 3,72 3,64 3,57 3,49
HCP212 HCP212-36 HCP212-37 HCP212-38 HCP212-39	60 2 ¼ 2 ⅞ 2 ⅞ 2 ⅞	69,8 2 ¾	241 9 ½	184 7 ¼	70 2 ¾	20 ⅞	23 ⅞	25 ⅞	138 5 ⅞	77,8 3,063	31 1,220	M16 ⅝	50 000	34 500	HC212 HC212-36 HC212-37 HC212-38 HC212-39	P212	5,24 5,40 5,31 5,26 5,13
HCP213 HCP213-40 HCP213-41	65 2 ½ 2 ⅞	76,2 3	265 10 ⅞	203 8	70 2 ¾	25 ⅞	28 ⅞	27 ⅞	150 5 ⅞	85,7 3,374	34,1 1,343	M20 ¾	54 700	38 000	HC213 HC213-40 HC213-41	P213	5,71 5,81 5,70
HCP214 HCP214-42 HCP214-43 HCP214-44	70 2 ⅞ 2 ⅞ 2 ¾	79,4 3 ⅞	266 10 ⅞	210 8 ⅞	72 2 ⅞	25 ⅞	28 ⅞	27 ⅞	156 6 ⅞	85,7 3,374	34,1 1,343	M20 ¾	59 000	42 000	HC214 HC214-42 HC214-43 HC214-44	P214	6,70 6,94 6,83 6,71
HCP215 HCP215-45 HCP215-46 HCP215-47 HCP215-48	75 2 ⅞ 2 ⅞ 2 ⅞ 3	82,6 3 ¼	275 10 ⅞	217 8 ⅞	74 2 ⅞	25 ⅞	28 ⅞	28 ⅞	162 6 ⅞	92,1 3,626	37,3 1,426	M20 ¾	63 000	47 000	HC215 HC215-45 HC215-46 HC215-47 HC215-48	P215	7,79 8,09 7,96 7,83 7,69



**UCLP2 Serie ribassata** *Height reduced Series*

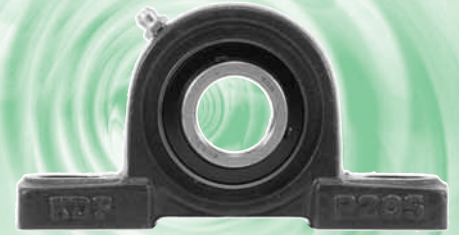
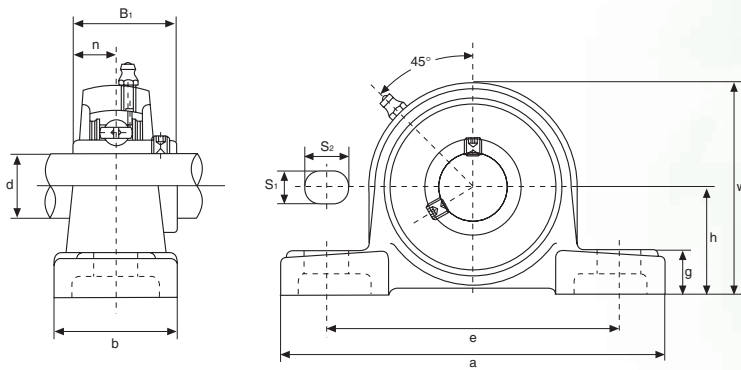

Tipo Type	Dimensioni mm/pollici Dimensions mm/inch											Bull. fiss. Bolt Size mm/inch	Coefficienti di carico (N) Load ratings (N)		Cuscinetto Bearing	Supporto Housing	Peso Weight (kg)
	d	h	a	e	b	S <sub>1</sub>	S <sub>2</sub>	g	w	B <sub>1</sub>	n		Dinamico C Dynamic C	Statico C <sub>0</sub> Static C <sub>0</sub>			
<b>UCLP201</b> <b>UCLP201-8</b>	12 ¾	31,75 1¼	127 5	95 3¾	38 1½	13 ½	16 ⅝	14 ⅞	64 2 <sup>33</sup> / <sub>64</sub>	31 1,2205	12,7 0,500	M10 ⅝	12 200	6 350	<b>UC201</b> <b>UC201-8</b>	<b>LP204</b>	0,69 0,69
<b>UCLP202</b> <b>UCLP202-9</b> <b>UCLP202-10</b>	15 ⅞ ⅝	31,75 1¼	127 5	95 3¾	38 1½	13 ½	16 ⅝	14 ⅞	64 2 <sup>33</sup> / <sub>64</sub>	31 1,2205	12,7 0,500	M10 ⅝	12 200	6 350	<b>UC202</b> <b>UC202-9</b> <b>UC202-10</b>	<b>LP204</b>	0,69 0,69 0,69
<b>UCLP203</b> <b>UCLP203-11</b>	17 1 <sup>1</sup> / <sub>16</sub>	31,75 1¼	127 5	95 3¾	38 1½	13 ½	16 ⅝	14 ⅞	64 2 <sup>33</sup> / <sub>64</sub>	31 1,2205	12,7 0,500	M10 ⅝	12 200	6 350	<b>UC203</b> <b>UC203-11</b>	<b>LP204</b>	0,68 0,67
<b>UCLP204</b> <b>UCLP204-12</b>	20 ¾	31,75 1¼	127 5	95 3¾	38 1½	13 ½	16 ⅝	14 ⅞	64 2 <sup>33</sup> / <sub>64</sub>	31 1,2205	12,7 0,500	M10 ⅝	12 200	6 350	<b>UC204</b> <b>UC204-12</b>	<b>LP204</b>	0,66 0,66
<b>UCLP205</b> <b>UCLP205-13</b> <b>UCLP205-14</b> <b>UCLP205-15</b> <b>UCLP205-16</b>	25 1 <sup>3</sup> / <sub>16</sub> 7 <sup>7</sup> / <sub>8</sub> 1 <sup>5</sup> / <sub>16</sub> 1	33,34 1 <sup>5</sup> / <sub>16</sub>	140 5½	105 4¼	38 1½	13 ½	16 ⅝	15 1 <sup>9</sup> / <sub>32</sub>	68 2 <sup>43</sup> / <sub>64</sub>	34,1 1,3425	14,3 0,563	M10 ⅝	13 300	7 500	<b>UC205</b> <b>UC205-13</b> <b>UC205-14</b> <b>UC205-15</b> <b>UC205-16</b>	<b>LP205</b>	0,81 0,85 0,83 0,82 0,81
<b>UCLP206</b> <b>UCLP206-17</b> <b>UCLP206-18</b> <b>UCLP206-19</b> <b>UCLP206-20</b>	30 1 <sup>1</sup> / <sub>16</sub> 1 <sup>1</sup> / <sub>8</sub> 1 <sup>3</sup> / <sub>16</sub> 1¼	39,69 1 <sup>9</sup> / <sub>16</sub>	165 6½	121 4¾	48 1 <sup>7</sup> / <sub>8</sub>	17 4 <sup>3</sup> / <sub>64</sub>	20 2 <sup>5</sup> / <sub>32</sub>	17 2 <sup>1</sup> / <sub>32</sub>	80 3 <sup>3</sup> / <sub>32</sub>	38,1 1,5000	15,9 0,626	M14 ½	18 600	10 800	<b>UC206</b> <b>UC206-17</b> <b>UC206-18</b> <b>UC206-19</b> <b>UC206-20</b>	<b>LP206</b>	1,24 1,27 1,26 1,24 1,23
<b>UCLP207</b> <b>UCLP207-20</b> <b>UCLP207-21</b> <b>UCLP207-22</b> <b>UCLP207-23</b>	35 1¼ 1 <sup>5</sup> / <sub>16</sub> 1 <sup>3</sup> / <sub>8</sub> 1 <sup>7</sup> / <sub>16</sub>	46,04 1 <sup>13</sup> / <sub>16</sub>	167 6 <sup>9</sup> / <sub>16</sub>	127 5	48 1 <sup>7</sup> / <sub>8</sub>	17 4 <sup>3</sup> / <sub>64</sub>	20 2 <sup>5</sup> / <sub>32</sub>	18 4 <sup>5</sup> / <sub>64</sub>	91 3 <sup>37</sup> / <sub>64</sub>	42,9 1,6890	17,5 0,689	M14 ½	24 500	14 600	<b>UC207</b> <b>UC207-20</b> <b>UC207-21</b> <b>UC207-22</b> <b>UC207-23</b>	<b>LP207</b>	1,58 1,64 1,61 1,58 1,55
<b>UCLP208</b> <b>UCLP208-24</b> <b>UCLP208-25</b>	40 1½ 1 <sup>9</sup> / <sub>16</sub>	49,2 1 <sup>15</sup> / <sub>16</sub>	184 7¼	137 5 <sup>13</sup> / <sub>32</sub>	54 2 <sup>1</sup> / <sub>8</sub>	17 4 <sup>3</sup> / <sub>64</sub>	20 2 <sup>5</sup> / <sub>32</sub>	18 4 <sup>5</sup> / <sub>64</sub>	100 3 <sup>15</sup> / <sub>16</sub>	49,2 1,9370	19 0,748	M14 ½	27 700	17 000	<b>UC208</b> <b>UC208-24</b> <b>UC208-25</b>	<b>LP208</b>	1,89 1,93 1,90
<b>UCLP209</b> <b>UCLP209-26</b> <b>UCLP209-27</b> <b>UCLP209-28</b>	45 1 <sup>5</sup> / <sub>8</sub> 1 <sup>11</sup> / <sub>16</sub> 1¾	52,39 2 <sup>1</sup> / <sub>16</sub>	190 7 <sup>15</sup> / <sub>32</sub>	146 5¾	54 2 <sup>1</sup> / <sub>8</sub>	17 4 <sup>3</sup> / <sub>64</sub>	20 2 <sup>5</sup> / <sub>32</sub>	20 2 <sup>5</sup> / <sub>32</sub>	104 4 <sup>3</sup> / <sub>32</sub>	49,2 1,9370	19 0,748	M14 ½	31 000	19 500	<b>UC209</b> <b>UC209-26</b> <b>UC209-27</b> <b>UC209-28</b>	<b>LP209</b>	2,14 2,24 2,20 2,14
<b>UCLP210</b> <b>UCLP210-29</b> <b>UCLP210-30</b> <b>UCLP210-31</b> <b>UCLP210-32</b>	50 1 <sup>13</sup> / <sub>16</sub> 1 <sup>7</sup> / <sub>8</sub> 1 <sup>15</sup> / <sub>16</sub> 2	55,56 2 <sup>3</sup> / <sub>16</sub>	206 8 <sup>1</sup> / <sub>8</sub>	159 6¼	60 2 <sup>3</sup> / <sub>8</sub>	20 2 <sup>5</sup> / <sub>32</sub>	23 2 <sup>9</sup> / <sub>32</sub>	21 5 <sup>3</sup> / <sub>64</sub>	112 4 <sup>13</sup> / <sub>32</sub>	51,6 2,0315	19 0,748	M16 ⅝	33 500	22 500	<b>UC210</b> <b>UC210-29</b> <b>UC210-30</b> <b>UC210-31</b> <b>UC210-32</b>	<b>LP210</b>	2,66 2,78 2,73 2,68 2,64
<b>UCLP211</b> <b>UCLP211-32</b> <b>UCLP211-33</b> <b>UCLP211-34</b> <b>UCLP211-35</b>	55 2 2 <sup>1</sup> / <sub>16</sub> 2 <sup>1</sup> / <sub>8</sub> 2 <sup>3</sup> / <sub>16</sub>	61,91 2 <sup>7</sup> / <sub>16</sub>	219 8 <sup>5</sup> / <sub>8</sub>	171 6 <sup>47</sup> / <sub>64</sub>	60 2 <sup>3</sup> / <sub>8</sub>	20 2 <sup>5</sup> / <sub>32</sub>	23 2 <sup>9</sup> / <sub>32</sub>	23 2 <sup>9</sup> / <sub>32</sub>	124 4 <sup>7</sup> / <sub>8</sub>	55,6 2,1890	22,2 0,874	M16 ⅝	41 500	28 000	<b>UC211</b> <b>UC211-32</b> <b>UC211-33</b> <b>UC211-34</b> <b>UC211-35</b>	<b>LP211</b>	3,31 3,46 3,40 3,35 3,29
<b>UCLP212</b> <b>UCLP212-36</b> <b>UCLP212-37</b> <b>UCLP212-38</b> <b>UCLP212-39</b>	60 2¼ 2 <sup>5</sup> / <sub>16</sub> 2 <sup>3</sup> / <sub>8</sub> 2 <sup>7</sup> / <sub>16</sub>	68,26 2 <sup>11</sup> / <sub>16</sub>	241 9½	184 7¼	70 2¾	20 2 <sup>5</sup> / <sub>32</sub>	23 2 <sup>9</sup> / <sub>32</sub>	25 6 <sup>3</sup> / <sub>64</sub>	136 5 <sup>23</sup> / <sub>64</sub>	65,1 2,5630	25,4 1,000	M16 ⅝	50 000	34 500	<b>UC212</b> <b>UC212-36</b> <b>UC212-37</b> <b>UC212-38</b> <b>UC212-39</b>	<b>LP212</b>	4,90 5,03 4,95 4,88 4,81

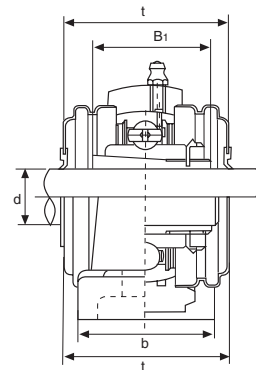
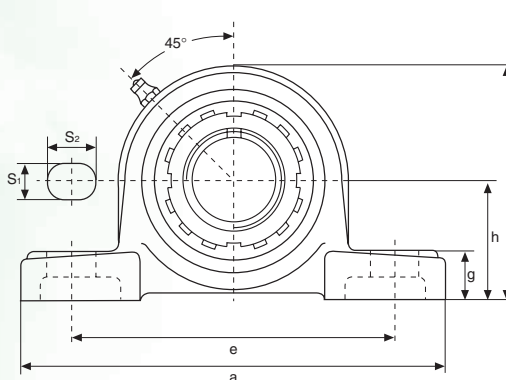
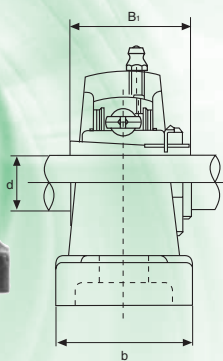

Tipo Type	Dimensioni mm/pollici Dimensions mm/inch											Bull. fiss. Bolt Size mm/inch	Coefficienti di carico (N) Load ratings (N)		Cuscinetto Bearing	Supporto Housing	Peso Weight (kg)
	d	h	a	e	b	S <sub>1</sub>	S <sub>2</sub>	g	w	t	B <sub>1</sub>		Dinamico C Dynamic C	Statico C <sub>0</sub> Static C <sub>0</sub>			
UKP205+H2305 UKP205+HE2305	20 ¾	36,5 1 7/16	140 5 ½	105 4 1/8	38 1 ½	13 ½	19 ¾	15 19/32	71 2 25/32	48 1 57/64	35 1,378	M10 ¾	13 500	7 500	UK205+H2305 UK205+HE2305	P205	0,86
UKP206+H2306 UKP206+HS2306 UKP206+HE2306	25 7/8 1	42,9 1 11/16	165 6 ½	121 4 ¾	48 1 7/8	17 43/64	20 25/32	17 43/64	84 3 5/16	53 2 5/64	38 1,496	M14 ½	18 600	10 800	UK206+H2306 UK206+HS2306 UK206+HE2306	P206	1,28
UKP207+H2307 UKP207+HS2307	30 1 1/8	47,6 1 7/8	167 6 9/16	127 5	48 1 7/8	17 43/64	20 25/32	18 45/64	93 3 21/32	59,5 2 11/32	43 1,693	M14 ½	24 500	14 600	UK207+H2307 UK207+HS2307	P207	1,67
UKP208+H2308 UKP208+HE2308 UKP208+HS2308	35 1 1/4 1 3/8	49,2 1 15/16	184 7 1/4	137 5 13/32	54 2 1/8	17 43/64	20 25/32	18 45/64	100 3 15/16	69 2 23/32	46 1,811	M14 ½	27 700	16 900	UK208+H2308 UK208+HE2308 UK208+HS2308	P208	1,99
UKP209+H2309 UKP209+HA2309 UKP209+HE2309 UKP209+HS2309	40 1 7/16 1 1/2 1 5/8	54 2 1/8	190 7 5/8	146 5 ¾	54 2 1/8	17 43/64	20 25/32	20 25/32	106 4 11/64	69 2 23/32	50 1,969	M14 ½	31 000	19 400	UK209+H2309 UK209+HA2309 UK209+HE2309 UK209+HS2309	P209	1,29
UKP210+H2310 UKP210+HS2310 UKP210+HA2310 UKP210+HE2310	45 1 5/8 1 11/16 1 3/4	57,2 2 1/4	206 8 1/8	159 6 1/4	60 2 3/8	20 25/32	23 29/32	21 53/64	113 4 29/64	74,5 2 15/16	55 2,165	M16 5/8	33 300	22 000	UK210+H2310 UK210+HS2310 UK210+HA2310 UK210+HE2310	P210	2,83
UKP211+H2311 UKP211+HS2311 UKP211+HA2311 UKP211+HE2311	50 1 7/8 1 15/16 2	63,5 2 1/2	219 8 5/8	171 6 7/8	60 2 3/8	20 25/32	23 29/32	23 29/32	125 4 59/64	76 3	59 2,323	M16 5/8	41 400	27 800	UK211+H2311 UK211+HS2311 UK211+HA2311 UK211+HE2311	P211	3,46
UKP212+H2312 UKP212+HS2312	55 2 1/8	69,8 2 3/4	241 9 1/2	184 7 1/4	70 2 3/4	20 25/32	23 29/32	25 63/64	138 5 7/16	89 3 1/2	62 2,441	M16 5/8	49 900	34 200	UK212+H2312 UK212+HS2312	P212	4,95
UKP213+H2313 UKP213+HA2313 UKP213+HE2313 UKP213+HS2313	60 2 3/16 2 1/4 2 3/8	76,2 3	265 10 7/16	203 8	70 2 3/4	25 63/64	28 1 1/8	27 1 1/16	150 5 29/32	89 3 1/2	65 2,559	M20 ¾	54 700	38 000	UK213+H2313 UK213+HA2313 UK213+HE2313 UK213+HS2313	P213	5,06
UKP215+H2315 UKP215+HA2315 UKP215+HE2315	65 2 7/16 2 1/2	82,6 3 1/4	275 10 53/64	217 8 35/64	74 2 29/32	25 63/64	28 1 1/8	28 1 1/8	162 6 3/8	-	73 2,874	M20 ¾	63 000	47 000	UK215+H2315 UK215+HA2315 UK215+HE2315	P215	7,27
UKP216+H2316 UKP216+HA2316 UKP216+HE2316	70 2 11/16 2 3/4	88,9 3 1/2	292 11 1/2	232 9 1/8	78 3 1/16	25 63/64	28 1 1/8	30 1 3/16	174 6 27/32	-	78 3,071	M20 ¾	68 900	51 000	UK216+H2316 UK216+HA2316 UK216+HE2316	P216	8,36
UKP217+H2317 UKP217+HA2317 UKP217+HE2317	75 2 15/16 3	95,2 3 3/4	310 12 13/64	247 9 23/32	83 3 17/64	25 63/64	28 1 1/8	32 1 1/4	185 7 9/32	-	82 3,228	M20 ¾	80 000	61 000	UK217+H2317 UK217+HA2317 UK217+HE2317	P217	10,23
UKP218+H2318 UKP218+HA2318	80 3 1/16	101,6 4	327 12 7/8	262 10 5/16	88 3 15/32	27 1 1/16	30 1 3/16	33 1 19/64	198 7 51/64	-	86 3,386	M22 7/8	91 200	68 000	UK218+H2318 UK218+HA2318	P218	12,34

Bussole HA; HE; HS con filettatura in pollici  
Inch dimension adapter sleeves HA; HE; HS





# SUPPORTI RITTI PILLOW BLOCK UNITS



## UCPX Serie media Medium Series

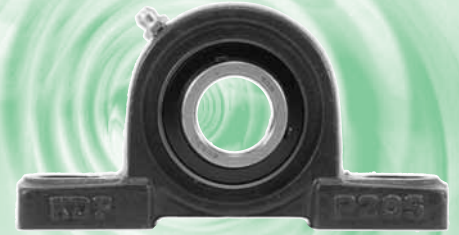
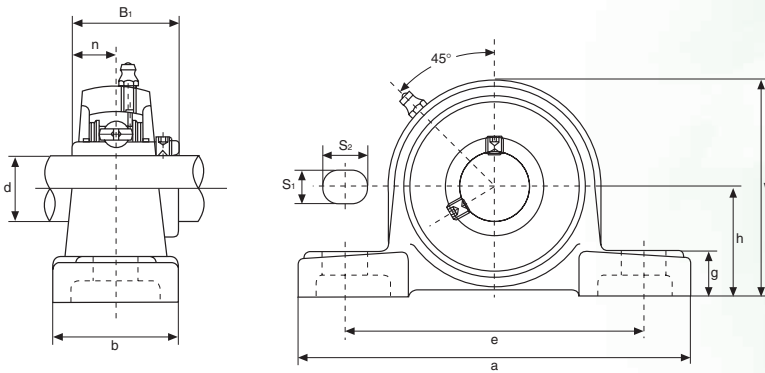

Tipo Type	Dimensioni mm/pollici Dimensions mm/inch											Bull. fiss. Bolt Size mm/inch	Coefficienti di carico (N) Load ratings (N)		Cuscinetto Bearing	Supporto Housing	Peso Weight (kg)
	d	h	a	e	b	S <sub>1</sub>	S <sub>2</sub>	g	w	B <sub>1</sub>	n		Dinamico C Dynamic C	Statico C <sub>0</sub> Static C <sub>0</sub>			
UCPX05 UCPX05-13 UCPX05-14 UCPX05-15 UCPX05-16	25 1 9/16 7/8 15/16 1	44,4 1 3/4	159 6 1/4	119 4 11/16	51 2	17 5/8	20 25/32	18 23/32	85 3 11/32	38,1 1,5000	15,9 0,626	M14 1/2	18 600 10 800	UCX05 UCX05-13 UCX05-14 UCX05-15 UCX05-16	PX05	1,5	
UCPX06 UCPX06-17 UCPX06-18 UCPX06-19 UCPX06-20	30 1 1/16 1 1/8 1 3/16 1 1/4	47,6 1 7/8	175 6 7/8	127 5	57 2 1/4	17 5/8	20 25/32	20 25/32	93 3 21/32	42,9 1,6890	17,5 0,689	M14 1/2	24 500 14 600	UCX06 UCX06-17 UCX06-18 UCX06-19 UCX06-20	PX06	2,0	
UCPX07 UCPX07-21 UCPX07-22 UCPX07-23	35 1 3/8 1 3/8 1 7/16	54,0 2 1/8	203 8	144 5 21/32	57 2 1/4	17 5/8	20 25/32	21 1 3/16	105 4 1/8	49,2 1,9370	19 0,748	M14 1/2	27 700 17 000	UCX07 UCX07-21 UCX07-22 UCX07-23	PX07	2,6	
UCPX08 UCPX08-24 UCPX08-25	40 1 1/2 1 9/16	58,7 2 5/16	222 8 3/4	156 6 5/32	67 2 5/8	20 25/32	23 29/32	26 1 1/32	111 4 3/8	49,2 1,9370	19 0,748	M16 5/8	30 900 19 400	UCX08 UCX08-24 UCX08-25	PX08	3,3	
UCPX09 UCPX09-26 UCPX09-27 UCPX09-28 UCPX09-29	45 1 3/8 1 11/16 1 3/4 1 13/16	58,7 2 5/16	222 8 3/4	156 6 5/32	67 2 5/8	20 25/32	23 29/32	26 1 1/32	116 4 9/16	51,6 2,0315	19 0,748	M16 5/8	33 000 22 100	UCX09 UCX09-26 UCX09-27 UCX09-28 UCX09-29	PX09	3,3	
UCPX10 UCPX10-30 UCPX10-31 UCPX10-32	50 1 7/8 1 15/16 2	63,5 2 1/2	241 9 1/2	171 6 7/8	73 2 7/8	20 25/32	23 29/32	27 1 1/16	126 4 31/32	55,6 2,1890	22,2 0,874	M16 5/8	41 400 27 800	UCX10 UCX10-30 UCX10-31 UCX10-32	PX10	4,3	
UCPX11 UCPX11-33 UCPX11-34 UCPX11-35 UCPX11-36 UCPX11-37	55 2 1/16 2 1/8 2 3/16 2 1/4 2 5/16	69,8 2 3/4	260 10 3/4	184 7 1/4	79 3 1/8	25 3 1/32	28 1 1/32	30 1 3/16	137 5 13/32	65,1 2,5630	25,4 1,000	M20 3/4	49 900 34 200	UCX11 UCX11-33 UCX11-34 UCX11-35 UCX11-36 UCX11-37	PX11	5,7	
UCPX12 UCPX12-38 UCPX12-39	60 2 3/8 2 7/16	76,2 3	286 11 1/4	203 8	83 3 3/32	25 3 1/32	28 1 1/32	33 1 5/16	151 5 15/16	65,1 2,5630	25,4 1,000	M20 3/4	54 700 38 000	UCX12 UCX12-38 UCX12-39	PX12	7,3	
UCPX13 UCPX13-40 UCPX13-41	65 2 1/2 2 9/16	76,2 3	286 11 1/4	203 8	83 3 3/32	25 5/8	28 1 1/32	33 1 5/16	154 6 1/16	74,6 2,9370	30,2 1,189	M20 3/4	58 900 41 800	UCX13 UCX13-40 UCX13-41	PX13	7,6	
UCPX14 UCPX14-42 UCPX14-43 UCPX14-44	70 2 5/8 2 11/16 2 3/4	88,9 3 1/2	330 13	229 9 1/32	89 3 1/2	27 1 1/16	30 1 3/16	35 1 3/8	170 6 11/16	77,8 3,0630	33,3 1,311	M22 7/8	63 000 47 100	UCX14 UCX14-42 UCX14-43 UCX14-44	PX14	9,9	
UCPX15 UCPX15-45 UCPX15-46 UCPX15-47 UCPX15-48	75 2 13/16 2 7/8 2 15/16 3	88,9 3 1/2	330 13	229 9 1/32	89 3 1/2	27 1 1/16	30 1 3/16	35 1 3/8	175 6 7/8	82,6 3,2520	33,3 1,311	M22 7/8	68 900 50 500	UCX15 UCX15-45 UCX15-46 UCX15-47 UCX15-48	PX15	11	
UCPX16 UCPX16-49 UCPX16-50 UCPX16-51 UCPX16-52	80 3 1/16 3 1/8 3 3/16 3 1/4	101,6 4	381 15	283 11 5/32	102 4 1/32	27 1 1/16	30 1 3/16	40 1 9/16	194 7 5/8	85,7 3,3740	34,1 1,343	M22 7/8	79 400 61 000	UCX16 UCX16-49 UCX16-50 UCX16-51 UCX16-52	PX16	15	
UCPX17 UCPX17-53 UCPX17-55	85 3 5/16 3 7/16	101,6 4	381 15	283 11 5/32	102 4 1/32	27 1 1/16	30 1 3/16	40 1 9/16	200 7 7/8	96 3,7795	39,7 1,563	M22 7/8	91 500 68 000	UCX17 UCX17-53 UCX17-55	PX17	16	
UCPX18 UCPX18-56 UCPX18-57	90 3 3/16 3 1/2	101,6 4	381 15	283 11 5/32	111 4 3/8	27 1 1/16	30 1 3/16	40 1 9/16	206 8 1/8	104 4,0945	42,9 1,689	M22 7/8	104 000 80 000	UCX18 UCX18-56 UCX18-57	PX18	17	
UCPX20 UCPX20-58 UCPX20-59 UCPX20-60 UCPX20-61	100 3 13/16 3 7/8 3 15/16 4	127 5	432 17	337 13 3/32	121 4 3/4	33 1 5/16	36 1 11/32	45 1 25/32	244 9 9/32	117,5 4,6260	49,2 1,937	M27 1	127 000 100 000	UCX20 UCX20-58 UCX20-59 UCX20-60 UCX20-61	PX20	30	

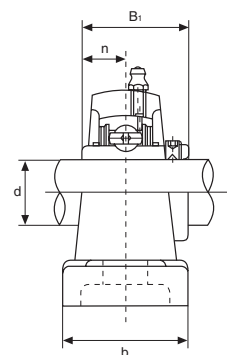
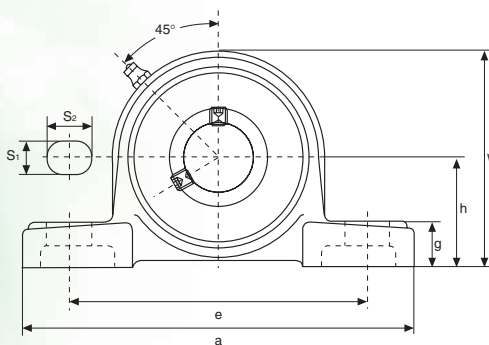
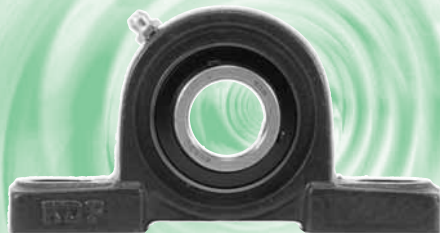

Tipo Type	Dimensioni mm/pollici Dimensions mm/inch											Bull. fiss. Bolt Size mm/inch	Coefficienti di carico (N) Load ratings (N)		Cuscinetto Bearing	Supporto Housing	Peso Weight (kg)
	d	h	a	e	b	S <sub>1</sub>	S <sub>2</sub>	g	w	B <sub>1</sub>	n		Dinamico C Dynamic C	Statico C <sub>0</sub> Static C <sub>0</sub>			
UCP305 UCP305-13 UCP305-14 UCP305-15 UCP305-16	25 1 1/16 7/8 15/16 1	45 1 1/2	175 6 7/8	132 5 1/16	45 1 25/32	17 4 3/4	20 2 5/32	15 1 9/32	85 3 11/32	38 1,4961	38 0,591	M14 1/2	20 200 11 930	UC305 UC305-13 UC305-14 UC305-15 UC305-16	P305	1,4	
UCP306 UCP306-17 UCP306-18 UCP306-19	30 1 1/16 1 1/8 1 3/16	50 1 31/32	180 7 3/32	140 5 1/2	50 1 31/32	17 4 3/4	20 2 5/32	18 2 3/32	95 3 3/4	43 1,6929	17 0,669	M14 1/2	25 400 14 300	UC306 UC306-17 UC306-18 UC306-19	P306	1,8	
UCP307 UCP307-20 UCP307-21 UCP307-22 UCP307-23	35 1 1/4 1 5/16 1 3/8 1 7/16	56 1 13/16	210 8 9/32	160 6 5/16	56 2 13/64	17 4 3/4	25 3 1/32	20 2 5/32	106 4 3/16	48 1,8898	19 1,748	M14 1/2	31 900 18 200	UC307 UC307-20 UC307-21 UC307-22 UC307-23	P307	2,8	
UCP308 UCP308-24 UCP308-25	40 1 1/2 1 9/16	60 2 23/64	220 8 21/32	170 6 11/16	60 2 3/8	17 4 3/4	27 1 11/16	22 7/8	116 4 9/16	52 2,0472	19 0,748	M14 1/2	38 500 23 000	UC308 UC308-24 UC308-25	P308	3,0	
UCP309 UCP309-26 UCP309-27 UCP309-28	45 1 3/8 1 11/16 1 3/4	67 2 41/64	245 9 21/32	190 7 15/32	67 2 5/8	20 2 5/32	30 1 3/16	24 1 5/16	129 5 3/32	57 2,2441	22 0,866	M16 5/8	50 500 30 500	UC309 UC309-26 UC309-27 UC309-28	P309	4,1	
UCP310 UCP310-29 UCP310-30 UCP310-31	50 1 13/16 1 7/8 1 15/16	75 2 51/64	275 10 13/16	212 8 11/32	75 2 15/16	20 2 5/32	35 1 3/8	27 1 1/16	143 5 5/8	61 2,4016	22 0,866	M16 5/8	59 000 36 600	UC310 UC310-29 UC310-30 UC310-31	P310	5,8	
UCP311 UCP311-32 UCP311-33 UCP311-34 UCP311-35	55 2 2 1/16 2 1/8 2 3/16	80 3 5/32	310 12 7/32	236 9 9/32	80 3 5/32	20 2 5/32	38 1 1/2	30 1 3/16	154 6 1/16	66 2,5984	25 0,984	M16 5/8	68 000 43 000	UC311 UC311-32 UC311-33 UC311-34 UC311-35	P311	7,4	
UCP312 UCP312-36 UCP312-37 UCP312-38 UCP312-39	60 2 1/4 2 5/16 2 3/8 2 7/16	85 3 11/32	330 13	250 9 17/32	85 3 11/32	25 3 1/32	38 1 1/2	32 1 1/4	165 6 1/2	71 2,7953	26 1,024	M20 3/4	78 000 49 500	UC312 UC312-36 UC312-37 UC312-38 UC312-39	P312	9,4	
UCP313 UCP313-40 UCP313-41	65 2 1/2 2 9/16	90 3 35/64	340 13 3/8	260 10 1/4	90 3 17/32	25 3 1/32	38 1 1/2	33 1 5/16	176 6 15/16	75 2,9528	30 1,181	M20 3/4	88 000 57 000	UC313 UC313-40 UC313-41	P313	10	
UCP314 UCP314-42 UCP314-43 UCP314-44	70 2 5/8 2 11/16 2 3/4	95 3 47/64	360 14 3/16	280 11 1/32	90 3 17/32	27 1 1/16	40 1 9/16	35 1 3/8	187 7 3/8	78 3,0708	33 1,299	M22 7/8	99 000 64 600	UC314 UC314-42 UC314-43 UC314-44	P314	12	
UCP315 UCP315-45 UCP315-46 UCP315-47 UCP315-48	75 2 13/16 2 7/8 2 15/16 3	100 3 15/16	380 14 31/32	290 11 13/32	100 3 15/16	27 1 1/16	40 1 9/16	35 1 3/8	198 7 25/32	82 3,2283	32 1,260	M22 7/8	108 000 73 500	UC315 UC315-45 UC315-46 UC315-47 UC315-48	P315	14	
UCP316 UCP316-49 UCP316-50 UCP316-51	80 3 1/16 3 1/8 3 3/16	106 4 11/64	400 15 3/4	300 11 13/16	110 4 11/32	27 1 1/16	40 1 9/16	40 1 9/16	210 8 3/32	86 3,3858	34 1,339	M22 7/8	117 000 83 000	UC316 UC316-49 UC316-50 UC316-51	P316	18	
UCP317 UCP317-52 UCP317-53 UCP317-55	85 3 1/4 3 5/16 3 7/16	112 4 13/32	420 16 7/32	320 12 19/32	110 4 11/32	33 1 5/16	45 1 25/32	40 1 9/16	220 8 21/32	96 3,7795	40 1,575	M27 1	127 000 93 000	UC317 UC317-52 UC317-53 UC317-55	P317	20	
UCP318 UCP318-55 UCP318-56	90 3 3/16 3 1/2	118 4 41/64	430 16 15/16	330 13	110 4 11/32	33 1 5/16	45 1 25/32	45 1 25/32	235 9 1/4	96 3,7795	40 1,575	M27 1	136 000 102 000	UC318 UC318-55 UC318-56	P318	24	
UCP319 UCP319-58 UCP319-59 UCP319-60	95 3 5/8 3 11/16 3 3/4	125 4 59/64	470 18 1/2	360 14 3/16	120 4 23/32	36 1 13/32	50 1 31/32	45 1 25/32	250 9 27/32	103 4,0551	41 1,614	M30 1 1/8	145 000 113 000	UC319 UC319-58 UC319-59 UC319-60	P319	29	
UCP320 UCP320-64	100 4	140 5 33/64	490 19 9/32	380 14 31/32	120 4 23/32	36 1 13/32	50 1 31/32	50 1 31/32	275 10 13/16	108 4,2520	42 1,654	M30 1 1/8	165 000 134 000	UC320 UC320-64	P320	35	



# SUPPORTI A FLANGIA QUADRA SQUARE FLANGE UNITS



## UCF2 Serie normale *Normal Series*

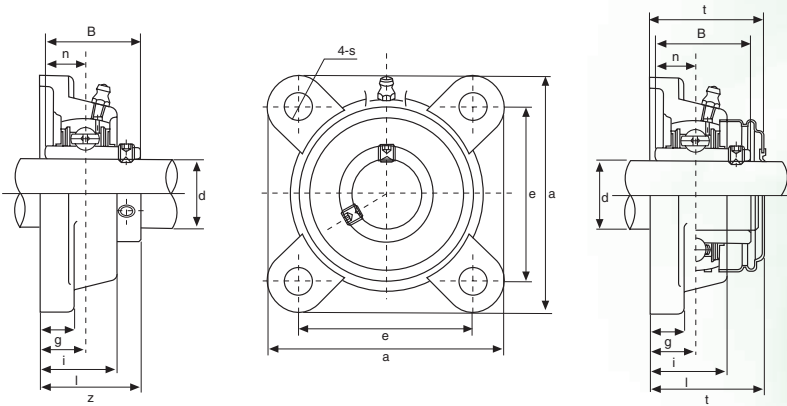

Tipo Type	Dimensioni mm/pollici Dimensions mm/inch											Bull. fiss. Bolt Size mm/inch	Coefficienti di carico (N) Load ratings (N)		Cuscinetto Bearing	Supporto Housing	Peso Weight (kg)
	d	a	e	i	g	l	s	z	t	B	n		Dinamico C Dynamic C	Statico C <sub>0</sub> Static C <sub>0</sub>			
UCF201 UCF201-8	12 3/4	86 3 3/8	64 2 3/8	15 1 1/2	12 1 1/2	25,5 1	12 1 1/2	33,3 1 3/16	37,5 1 3/8	31 1,2205	12,7 0,500	M10 3/8	12 200	6 350	UC201 UC201-8	F204	0,60 0,59
UCF202 UCF202-9 UCF202-10	15 9/16 5/8	86 3 3/8	64 2 3/8	15 1 1/2	12 1 1/2	25,5 1	12 1 1/2	33,3 1 1/16	37,5 1 3/16	31 1,2205	12,7 0,500	M10 3/8	12 200	6 350	UC202 UC202-9 UC202-10	F204	0,59 0,59 0,59
UCF203 UCF203-11	17 1 1/16	86 3 3/8	64 2 3/8	15 1 1/2	12 1 1/2	25,5 1	12 1 1/2	33,3 1 1/16	37,5 1 3/16	31 1,2205	12,7 0,500	M10 3/8	12 200	6 350	UC203 UC203-11	F204	0,58 0,57
UCF204 UCF204-12	20 3/4	86 3 3/8	64 2 3/8	15 1 1/2	12 1 1/2	25,5 1	12 1 1/2	33,3 1 1/16	37,5 1 3/16	31 1,2205	12,7 0,500	M10 3/8	12 200	6 350	UC204 UC204-12	F204	0,56 0,56
UCF205 UCF205-13 UCF205-14 UCF205-15 UCF205-16	25 1 9/16 7/8 1 1/16 1	95 3 3/4	70 2 3/4	16 5/8	14 3 5/8	27 1 1/16	12 1 5/8	35,8 1 11/32	40 1 9/16	34,1 1,3425	14,3 0,563	M10 3/8	13 300	7 500	UC205 UC205-13 UC205-14 UC205-15 UC205-16	F205	0,80 0,84 0,83 0,81 0,80
UCF206 UCF206-17 UCF206-18 UCF206-19 UCF206-20	30 1 1/16 1 1/8 1 3/16 1 1/4	108 4 1/4	83 3 17/64	18 4 5/8	14 3 5/8	31 1 7/32	12 1 5/8	40,2 1 11/32	44,5 1 3/4	38,1 1,5000	15,9 0,626	M10 3/8	18 600	10 800	UC206 UC206-17 UC206-18 UC206-19 UC206-20	F206	1,12 1,15 1,14 1,12 1,11
UCF207 UCF207-20 UCF207-21 UCF207-22 UCF207-23	35 1 1/4 1 3/16 1 3/8 1 7/16	117 4 39/64	92 3 5/8	19 3/4	16 5/8	34 1 11/32	14 3 5/8	44,4 1 7/8	48,5 1 29/32	42,9 1,6890	17,5 0,689	M12 7/16	24 500	14 600	UC207 UC207-20 UC207-21 UC207-22 UC207-23	F207	1,46 1,52 1,49 1,46 1,43
UCF208 UCF208-24 UCF208-25	40 1 1/2 1 9/16	130 5 1/8	102 4 1/4	21 5 3/8	16 5/8	36 1 27/64	16 5/8	51,2 2 1/4	55,5 2 3/16	49,2 1,9370	19 0,748	M14 1/2	27 700	17 000	UC208 UC208-24 UC208-25	F208	1,84 1,88 1,85
UCF209 UCF209-26 UCF209-27 UCF209-28	45 1 5/8 1 11/16 1 3/4	137 5 13/32	105 4 9/16	22 5 5/8	18 2 3/8	38 1 1/2	16 5/8	52,2 2 1/16	56,5 2 7/32	49,2 1,9370	19 0,748	M14 1/2	31 000	19 500	UC209 UC209-26 UC209-27 UC209-28	F209	2,15 2,25 2,21 2,17
UCF210 UCF210-29 UCF210-30 UCF210-31 UCF210-32	50 1 13/16 1 7/8 1 15/16 2	143 5 5/8	111 4 3/8	22 5 5/8	18 2 3/8	40 1 9/16	16 5/8	54,6 2 1/8	59,5 2 11/32	51,6 2,0315	19 0,748	M14 1/2	33 500	22 500	UC210 UC210-29 UC210-30 UC210-31 UC210-32	F210	2,42 2,54 2,49 2,44 2,40
UCF211 UCF211-32 UCF211-33 UCF211-34 UCF211-35	55 2 2 1/16 2 1/8 2 3/16	162 6 3/8	130 5 1/8	25 6 3/8	20 2 5/8	43 1 11/16	19 3/4	58,4 1 5/16	63 2 31/64	55,6 2,1890	22,2 0,874	M16 5/8	41 500	28 000	UC211 UC211-32 UC211-33 UC211-34 UC211-35	F211	3,31 3,46 3,40 3,35 3,29
UCF212 UCF212-36 UCF212-37 UCF212-38 UCF212-39	60 2 1/4 2 5/16 2 3/8 2 7/16	175 6 57/64	143 5 5/8	29 1 9/16	20 2 5/8	48 1 57/64	19 3/4	68,7 2 45/64	73,5 2 57/64	65,1 2,5630	25,4 1,000	M16 5/8	50 000	34 500	UC212 UC212-36 UC212-37 UC212-38 UC212-39	F212	4,28 4,41 4,33 4,26 4,19
UCF213 UCF213-40 UCF213-41	65 2 1/2 2 9/16	187 7 23/64	149 5 55/64	30 1 3/16	22 5 5/8	50 1 31/32	19 3/4	69,7 2 3/4	74,5 2 15/16	65,1 2,5630	25,4 1,000	M16 5/8	54 700	38 000	UC213 UC213-40 UC213-41	F213	4,99 5,08 4,99
UCF214 UCF214-42 UCF214-43 UCF214-44	70 2 5/8 2 11/16 2 3/4	193 7 19/32	152 5 63/64	31 1 7/8	22 5 5/8	54 2 1/8	19 3/4	75,4 2 31/32	- 2,9370	74,6 1,189	30,2	M16 5/8	59 000	42 000	UC214 UC214-42 UC214-43 UC214-44	F214	5,85 6,06 5,96 5,86
UCF215 UCF215-45 UCF215-46 UCF215-47 UCF215-48	75 2 13/16 2 7/8 2 15/16 3	200 7 7/8	159 6 17/64	34 1 11/32	22 5 5/8	56 2 7/32	19 3/4	78,5 3 3/32	- 3,0630	77,8 1,311	33,3	M16 5/8	63 000	47 000	UC215 UC215-45 UC215-46 UC215-47 UC215-48	F215	6,91 7,16 7,05 6,94 6,82
UCF216 UCF216-49 UCF216-50 UCF216-51	80 3 1/16 3 1/8 3 3/16	208 8 3/16	165 6 1/2	34 1 11/32	22 5 5/8	58 2 9/32	23 2 9/32	83,3 3 9/32	- 3,2520	82,6 1,311	33,3	M20 3/4	69 000	51 000	UC216 UC216-49 UC216-50 UC216-51	F216	7,50 7,68 7,55 7,42
UCF217 UCF217-52 UCF217-53 UCF217-55	85 3 1/4 3 5/16 3 7/16	220 8 21/32	175 6 57/64	36 1 27/64	24 1 5/16	63 2 15/32	23 2 9/32	87,6 3 7/16	- 3,3740	85,7 1,343	34,1	M20 3/4	80 000	61 000	UC217 UC217-52 UC217-53 UC217-55	F217	9,66 9,88 9,74 9,45
UCF218 UCF218-56	90 3 1/2	235 9 1/4	187 7 23/64	40 1 37/64	24 1 9/16	68 2 11/16	23 2 9/32	96,3 3 25/32	- 3,7795	96 1,5630	39,7	M20 3/4	91 200	68 000	UC218 UC218-56	F218	12,06 12,17

Disponibile in acciaio inox Supporto: AISI 304 - Cuscinetto: AISI 440C  
Disponibile su richiesta con cuscinetto SA (SAF..)



Available stainless steel Housing: AISI 304 - Bearing: AISI 440C  
Available under request with SA bearing (SAF..)

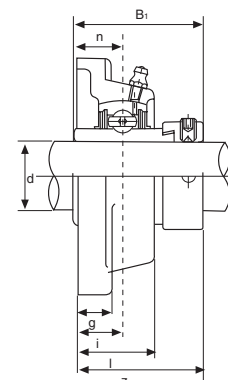
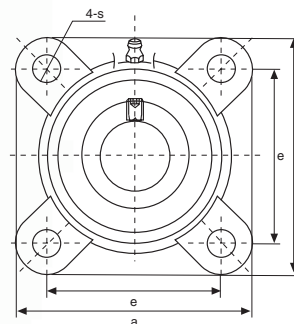

Tipo Type	Dimensioni mm/pollici Dimensions mm/inch										Bull. fiss. Bolt Size mm/inch	Coefficienti di carico (N) Load ratings (N)		Cuscinetto Bearing	Supporto Housing	Peso Weight (kg)
	d	a	e	i	g	l	s	z	B <sub>1</sub>	n		Dinamico C Dynamic C	Statico C <sub>0</sub> Static C <sub>0</sub>			
HCF204 HCF204-12	20 3/4	86 3 3/8	64 2 3/4	15 1 1/2	12 1 1/2	25,5 1	12 1 1/2	41,6 1 1/4	43,7 1,720	17,1 0,673	M10 3/8	12 200	6 350	HC204 HC204-12	F204	0,63 0,63
HCF205 HCF205-13 HCF205-14 HCF205-15 HCF205-16	25 1 1/8 7/8 1 1/8 1	95 3 3/4	70 2 3/4	16 5/8	14 3 5/8	27 1 1/8	12 1 1/2	42,9 1 1/4	44,4 1,748	17,5 0,689	M10 3/8	13 300	7 500	HC205 HC205-13 HC205-14 HC205-15 HC205-16	F205	0,87 0,92 0,91 0,89 0,87
HCF206 HCF206-17 HCF206-18 HCF206-19 HCF206-20	30 1 1/8 1 1/8 1 3/8 1 1/4	108 4 1/4	83 3 1/4	18 4 5/8	14 3 5/8	31 1 1/4	12 1 1/2	48,1 1 5/8	48,4 1,906	18,3 0,720	M10 3/8	18 600	10 800	HC206 HC206-17 HC206-18 HC206-19 HC206-20	F206	1,25 1,30 1,27 1,25 1,24
HCF207 HCF207-20 HCF207-21 HCF207-22 HCF207-23	35 1 1/4 1 5/8 1 3/8 1 7/8	117 4 3/8	92 3 5/8	19 3/4	16 5/8	34 1 1/2	14 3 5/8	51,3 2 1/8	51,1 2,012	18,8 0,740	M12 7/16	24 500	14 600	HC207 HC207-20 HC207-21 HC207-22 HC207-23	F207	1,58 1,65 1,61 1,58 1,55
HCF208 HCF208-24 HCF208-25	40 1 1/2 1 9/16	130 5 1/8	102 4 1/4	21 5 3/8	16 5/8	36 1 27/32	16 5/8	55,9 2 13/64	56,3 2,217	21,4 0,843	M14 1/2	27 700	17 000	HC208 HC208-24 HC208-25	F208	1,99 2,04 2,00
HCF209 HCF209-26 HCF209-27 HCF209-28	45 1 5/8 1 11/16 1 3/4	137 5 13/32	105 4 9/16	22 5 5/8	18 5 5/8	38 1 1/2	16 5/8	56,9 2 15/64	56,3 2,217	21,4 0,843	M14 1/2	31 000	19 500	HCF209 HC209-26 HC209-27 HC209-28	F209	2,32 2,43 2,38 2,34
HCF210 HCF210-29 HCF210-30 HCF210-31 HCF210-32	50 1 13/16 1 7/8 1 15/16 2	143 5 5/8	111 4 3/8	22 5 5/8	18 2 3/32	40 1 9/16	16 5/8	60,1 2 3/8	62,7 2,469	24,6 0,969	M14 1/2	33 500	22 500	HCF210 HC210-29 HC210-30 HC210-31 HC210-32	F210	2,61 2,76 2,70 2,64 2,58
HCF211 HCF211-32 HCF211-33 HCF211-34 HCF211-35	55 2 2 1/16 2 1/8 2 3/16	162 6 3/8	130 5 1/8	25 6 3/8	20 2 5/32	43 1 11/16	19 3/4	68,6 2 45/64	71,4 2,811	27,8 1,094	M16 5/8	41 500	28 000	HCF211 HC211-32 HC211-33 HC211-34 HC211-35	F211	3,52 3,72 3,64 3,57 3,49
HCF212 HCF212-36 HCF212-37 HCF212-38 HCF212-39	60 2 1/4 2 5/16 2 3/8 2 7/16	175 6 57/64	143 5 5/8	29 1 9/16	20 2 5/32	48 1 57/64	19 3/4	75,8 2 63/64	77,8 3,063	31 1,220	M16 5/8	50 000	34 500	HC212 HC212-36 HC212-37 HC212-38 HC212-39	F212	4,62 4,78 4,69 4,64 4,51
HCF213 HCF213-40 HCF213-41	65 2 1/2 2 9/16	187 7 23/64	149 5 55/64	30 1 3/16	22 5 5/8	50 1 31/32	19 3/4	81,6 3 7/32	85,7 3,374	34,1 1,343	M16 5/8	54 700	38 000	HC213 HC213-40 HC213-41	F213	5,55 5,65 5,54
HCF214 HCF214-42 HCF214-43 HCF214-44	70 2 3/8 2 11/16 2 3/4	193 7 19/32	152 5 63/64	31 1 7/32	22 5 5/8	54 2 1/8	19 3/4	82,6 3 1/4	85,7 3,374	34,1 1,343	M16 5/8	59 000	42 000	HC214 HC214-42 HC214-43 HC214-44	F214	6,35 6,59 6,48 6,36
HCF215 HCF215-45 HCF215-46 HCF215-47 HCF215-48	75 2 13/16 2 7/8 2 15/16 3	200 7 7/8	159 6 1 7/8	34 1 11/32	22 5 5/8	56 2 7/32	19 3/4	88,8 3 1/2	92,1 3,626	37,3 1,426	M16 5/8	63 000	47 000	HC215 HC215-45 HC215-46 HC215-47 HC215-48	F215	7,54 7,84 7,71 7,58 7,44



# SUPPORTI A FLANGIA QUADRA CON BUSSOLA MONTATA SQUARE FLANGE UNITS WITH ADAPTER SLEEVE MOUNTED



## UKF2 Serie normale Normal Series

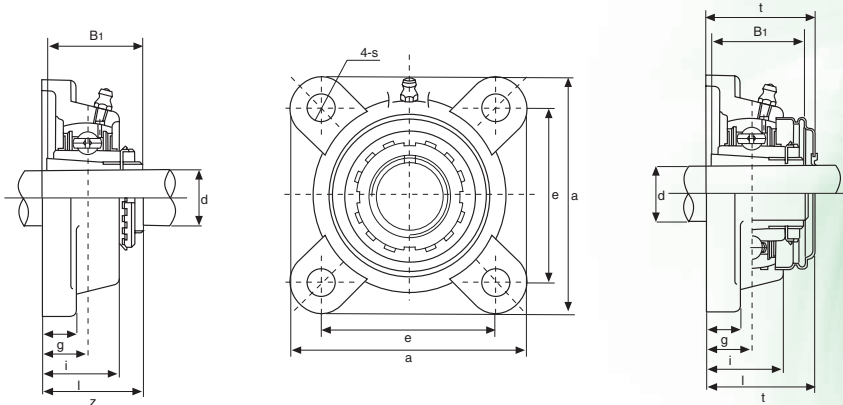

Tipo Type	Dimensioni mm/pollici Dimensions mm/inch										Bull. fiss. Bolt Size mm/inch	Coefficienti di carico (N) Load ratings (N)		Cuscinetto Bearing	Supporto Housing	Peso Weight (kg)
	d	a	e	i	g	l	s	z	t	B <sub>1</sub>		Dinamico C Dynamic C	Statico C <sub>0</sub> Static C <sub>0</sub>			
UKF205+H2305 UKF205+HE2305	20 3/4	95 3 3/4	70 2 3/4	16 5/8	14 39/64	27 1 1/16	12 15/32	35,5 1 25/64	40 1 9/16	35 1,378	M10 3/8	13 500	7 500	UK205+H2305 UK205+HE2305	F205	0,85
UKF206+H2306 UKF206+HS2306 UKF206+HE2306	25 7/8 1	108 4 1/4	83 3 17/64	18 45/64	14 35/64	31 1 7/32	12 15/32	39 1 17/32	44,5 1 3/4	38 1,496	M10 3/8	18 600	10 800	UK206+H2306 UK206+HS2306 UK206+HE2306	F206	1,16
UKF207+H2307 UKF207+HS2307	30 1 1/8	117 4 9/64	92 3 5/8	19 3/4	16 5/8	34 1 11/32	14 39/64	42,5 1 43/64	48,5 1 29/32	43 1,693	M12 7/16	24 500	14 600	UK207+H2307 UK207+HS2307	F207	1,55
UKF208+H2308 UKF208+HE2308 UKF208+HS2308	35 1 1/4 1 3/8	130 5 1/8	102 4 1/64	21 53/64	16 5/8	36 1 27/64	16 5/8	46,5 1 53/64	55,5 2 1/16	46 1,811	M14 1/2	27 700	16 900	UK208+H2308 UK208+HE2308 UK208+HS2308	F208	1,94
UKF209+H2309 UKF209+HA2309 UKF209+HE2309 UKF209+HS2309	40 1 7/16 1 1/2 1 5/8	137 5 13/32	105 4 9/64	22 55/64	18 23/32	38 1 1/2	16 5/8	48,5 1 29/32	56,5 2 7/32	50 1,969	M14 1/2	31 000	19 400	UK209+H2309 UK209+HA2309 UK209+HE2309 UK209+HS2309	F209	2,30
UKF210+H2310 UKF210+HE2310 UKF210+HA2310 UKF210+HE2310	45 1 5/8 1 11/16 1 3/4	143 5 5/8	111 4 3/8	22 55/64	18 23/32	40 1 9/16	16 5/8	50 1 31/32	59,5 2 11/32	55 2,165	M14 1/2	33 300	22 000	UK210+H2310 UK210+HE2310 UK210+HA2310 UK210+HE2310	F210	2,59
UKF211+H2311 UKF211+HS2311 UKF211+HA2311 UKF211+HE2311	50 1 7/8 1 15/16 2	162 6 3/8	130 5 1/8	25 63/64	20 25/32	43 1 11/16	19 3/4	54,5 2 9/64	63 2 31/64	59 2,323	M16 5/8	41 400	27 800	UK211+H2311 UK211+HS2311 UK211+HA2311 UK211+HE2311	F211	3,46
UKF212+H2312 UKF212+HS2312	55 2 1/8	175 6 57/64	143 5 5/8	29 1 9/64	20 25/32	48 1 57/64	19 3/4	61 2 13/32	73,5 2 57/64	62 2,441	M16 5/8	49 900	34 200	UK212+H2312 UK212+HS2312	F212	4,33
UKF213+H2313 UKF213+HA2313 UKF213+HE2313 UKF213+HS2313	60 2 3/16 2 1/4 2 3/8	187 7 23/64	149 5 55/64	30 1 3/16	22 55/64	50 1 31/32	19 3/4	64 2 33/64	74,5 2 15/16	65 2,559	M16 5/8	54 700	38 000	UK213+H2313 UK213+HA2313 UK213+HE2313 UK213+HS2313	F213	4,90
UKF215+H2315 UKF215+HA2315 UKF215+HE2315	65 2 7/16 2 1/2	200 7 7/8	159 6 17/64	34 1 11/32	22 55/64	56 2 7/32	19 3/4	71 2 51/64	-	73 2,874	M16 5/8	63 000	47 000	UK215+H2315 UK215+HA2315 UK215+HE2315	F215	7,02
UKF216+H2316 UKF216+HA2316 UKF216+HE2316	70 2 11/16 2 3/4	208 8 3/16	165 6 1/2	34 1 11/32	22 55/64	58 2 9/32	23 29/32	73,5 2 57/64	-	78 3,071	M20 3/4	68 900	51 000	UK216+H2316 UK216+HA2316 UK216+HE2316	F216	7,76
UKF217+H2317 UKF217+HA2317 UKF217+HE2317	75 2 15/16 3	220 8 21/32	175 6 57/64	36 1 27/64	24 15/16	63 2 15/32	23 29/32	77 3 1/32	-	82 3,228	M20 3/4	80 000	61 000	UK217+H2317 UK217+HA2317 UK217+HE2317	F217	10,08
UKF218+H2318 UKF218+HA2318	80 3 1/16	235 9 1/4	187 7 23/64	40 1 37/64	24 15/16	68 2 11/16	23 29/32	81,5 3 13/64	-	86 3,386	M20 3/4	91 200	68 000	UK218+H2318 UK218+HA2318	F218	12,44

Bussole HA; HE; HS con filettatura in pollici  
Inch dimension adapter sleeves HA; HE; HS

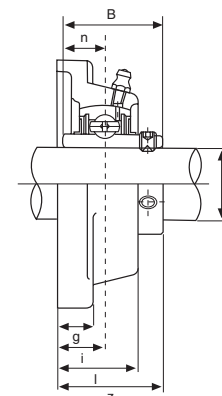
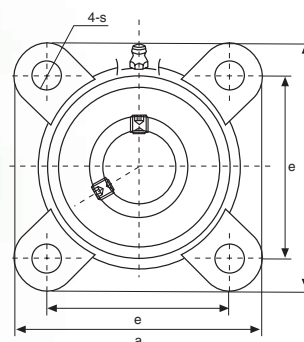

Tipo Type	Dimensioni mm/pollici Dimensions mm/inch										Bull. fiss. Bolt Size mm/inch	Coefficienti di carico (N) Load ratings (N)		Cuscinetto Bearing	Supporto Housing	Peso Weight (kg)
	d	a	e	i	g	l	s	z	B	n		Dinamico C Dynamic C	Statico C <sub>0</sub> Static C <sub>0</sub>			
UCFX05 UCFX05-13 UCFX05-14 UCFX05-15 UCFX05-16	25 1 <sup>9</sup> / <sub>16</sub> 7/8 15/16 1	108	83	18	13	30	12	40,2	38,1	15,9	M10	18 600	10 800	UCX05 UCX05-13 UCX05-14 UCX05-15 UCX05-16	FX05	1,0
UCFX06 UCFX06-17 UCFX06-18 UCFX06-19 UCFX06-20	30 1 <sup>1</sup> / <sub>8</sub> 1 <sup>1</sup> / <sub>8</sub> 1 <sup>3</sup> / <sub>16</sub> 1 <sup>1</sup> / <sub>4</sub>	117	92	19	14	34	16	44,4	42,9	17,5	M14	24 500	14 600	UCX06 UCX06-17 UCX06-18 UCX06-19 UCX06-20	FX06	1,7
UCFX07 UCFX07-21 UCFX07-22 UCFX07-23	35 1 <sup>5</sup> / <sub>16</sub> 1 <sup>3</sup> / <sub>8</sub> 1 <sup>7</sup> / <sub>16</sub>	130	102	21	14	38	16	51,2	49,2	19	M14	27 700	17 000	UCX07 UCX07-21 UCX07-22 UCX07-23	FX07	2,1
UCFX08 UCFX08-24 UCFX08-25	40 1 <sup>1</sup> / <sub>2</sub> 1 <sup>9</sup> / <sub>16</sub>	137	105	22	14	40	19	52,2	49,2	19	M16	30 900	19 400	UCX08 UCX08-24 UCX08-25	FX08	2,4
UCFX09 UCFX09-26 UCFX09-27 UCFX09-28 UCFX09-29	45 1 <sup>7</sup> / <sub>8</sub> 1 <sup>11</sup> / <sub>16</sub> 1 <sup>3</sup> / <sub>4</sub> 1 <sup>13</sup> / <sub>16</sub>	143	111	23	14	40	19	55,6	51,6	19	M16	33 000	22 100	UCX09 UCX09-26 UCX09-27 UCX09-28 UCX09-29	FX09	2,5
UCFX10 UCFX10-30 UCFX10-31 UCFX10-32	50 1 <sup>7</sup> / <sub>8</sub> 1 <sup>13</sup> / <sub>16</sub> 2	162	130	26	20	44	19	59,4	55,6	22,2	M16	41 400	27 800	UCX10 UCX10-30 UCX10-31 UCX10-32	FX10	3,9
UCFX11 UCFX11-33 UCFX11-34 UCFX11-35 UCFX11-36 UCFX11-37	55 2 <sup>1</sup> / <sub>16</sub> 2 <sup>1</sup> / <sub>8</sub> 2 <sup>3</sup> / <sub>16</sub> 2 <sup>1</sup> / <sub>4</sub> 2 <sup>5</sup> / <sub>16</sub>	175	143	29	20	49	19	68,7	65,1	25,4	M16	49 900	34 200	UCX11 UCX11-33 UCX11-34 UCX11-35 UCX11-36 UCX11-37	FX11	4,9
UCFX12 UCFX12-38 UCFX12-39	60 2 <sup>3</sup> / <sub>8</sub> 2 <sup>7</sup> / <sub>16</sub>	187	149	34	21	59	19	73,7	65,1	25,4	M16	54 700	38 000	UCX12 UCX12-38 UCX12-39	FX12	5,2
UCFX13 UCFX13-40 UCFX13-41	65 2 <sup>1</sup> / <sub>2</sub> 2 <sup>9</sup> / <sub>16</sub>	187	149	34	21	59	19	78,4	74,6	30,2	M16	58 900	41 800	UCX13 UCX13-40 UCX13-41	FX13	5,3
UCFX14 UCFX14-42 UCFX14-43 UCFX14-44	70 2 <sup>5</sup> / <sub>8</sub> 2 <sup>11</sup> / <sub>16</sub> 2 <sup>3</sup> / <sub>4</sub>	197	152	37	24	60	23	81,5	77,8	33,3	M20	63 000	47 100	UCX14 UCX14-42 UCX14-43 UCX14-44	FX14	7,3
UCFX15 UCFX15-45 UCFX15-46 UCFX15-47 UCFX15-48	75 2 <sup>13</sup> / <sub>16</sub> 2 <sup>7</sup> / <sub>8</sub> 2 <sup>15</sup> / <sub>16</sub> 3	197	152	40	24	68	23	89,3	82,6	33,3	M20	68 900	50 500	UCX15 UCX15-45 UCX15-46 UCX15-47 UCX15-48	FX15	8,1
UCFX16 UCFX16-49 UCFX16-50 UCFX16-51 UCFX16-52	80 3 <sup>1</sup> / <sub>16</sub> 3 <sup>1</sup> / <sub>8</sub> 3 <sup>3</sup> / <sub>16</sub> 3 <sup>1</sup> / <sub>4</sub>	214	171	40	24	70	23	91,6	85,7	34,1	M20	79 400	61 000	UCX16 UCX16-49 UCX16-50 UCX16-51 UCX16-52	FX16	9,9
UCFX17 UCFX17-53 UCFX17-55	85 3 <sup>3</sup> / <sub>16</sub> 3 <sup>7</sup> / <sub>16</sub>	214	171	40	24	70	23	93,3	96	39,7	M20	91 500	68 000	UCX17 UCX17-53 UCX17-55	FX17	11
UCFX18 UCFX18-56 UCFX18-57	90 3 <sup>7</sup> / <sub>16</sub> 3 <sup>1</sup> / <sub>2</sub>	214	171	45	24	76	23	106,1	104	42,9	M20	104 000	80 000	UCX18 UCX18-56 UCX18-57	FX18	11
UCFX20 UCFX20-58 UCFX20-59 UCFX20-60 UCFX20-61	100 3 <sup>13</sup> / <sub>16</sub> 3 <sup>7</sup> / <sub>8</sub> 3 <sup>15</sup> / <sub>16</sub> 4	268	211	59	31	97	31	127,3	117,5	49,2	M27	127 000	100 000	UCX20 UCX20-58 UCX20-59 UCX20-60 UCX20-61	FX20	17



# SUPPORTI A FLANGIA QUADRA SQUARE FLANGE UNITS

# KDF®

## UCF3 Serie pesante Heavy Series

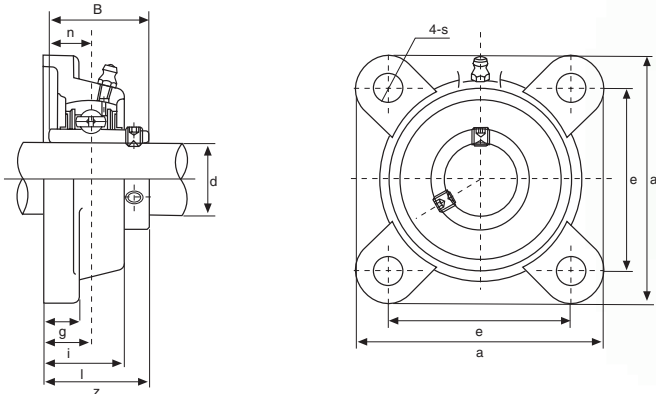

Tipo Type	Dimensioni mm/pollici Dimensions mm/inch										Bull. fiss. Bolt Size mm/inch	Coefficienti di carico (N) Load ratings (N)		Cuscinetto Bearing	Supporto Housing	Peso Weight (kg)
	d	a	e	i	g	l	s	z	B	n		Dinamico C Dynamic C	Statico C <sub>0</sub> Static C <sub>0</sub>			
UCF305 UCF305-13 UCF305-14 UCF305-15 UCF305-16	25 1 1/16 7/8 15/16 1	110 4 1/32	80 3 5/32	16 5/8	13 1/2	29 1 5/32	16 5/8	39 1 17/32	38 1,4961	15 0,591	M14 1/2	20 200 11 930	UC305 UC305-13 UC305-14 UC305-15 UC305-16	F305	1,1	
UCF306 UCF306-17 UCF306-18 UCF306-19	30 1 1/16 1 1/8 1 3/16	125 4 29/32	95 3 37/64	18 4 5/64	15 1 9/32	32 1 1/4	16 5/8	44 1 47/64	43 1,6929	17 0,669	M14 1/2	25 400 14 300	UC306 UC306-17 UC306-18 UC306-19	F306	1,6	
UCF307 UCF307-20 UCF307-21 UCF307-22 UCF307-23	35 1 1/4 1 5/16 1 3/8 1 7/16	135 5 5/16	100 3 15/16	20 2 5/32	16 5/8	36 1 13/32	19 3/4	49 1 59/64	48 1,8898	19 0,748	M16 5/8	31 900 18 200	UC307 UC307-20 UC307-21 UC307-22 UC307-23	F307	2	
UCF308 UCF308-24 UCF308-25	40 1 1/2 1 9/16	150 5 29/32	112 4 13/32	23 2 9/32	17 2 1/32	40 1 9/16	19 3/4	56 2 13/64	52 2,0472	19 0,748	M16 5/8	38 500 23 000	UC308 UC308-24 UC308-25	F308	2,7	
UCF309 UCF309-26 UCF309-27 UCF309-28	45 1 5/8 1 11/16 1 3/4	160 6 5/16	125 4 59/64	25 6 3/64	18 2 3/32	44 1 23/32	19 3/4	60 2 23/64	57 2,2441	22 0,866	M16 5/8	50 500 30 500	UC309 UC309-26 UC309-27 UC309-28	F309	3,4	
UCF310 UCF310-29 UCF310-30 UCF310-31	50 1 13/16 1 7/8 1 15/16	175 6 7/8	132 5 13/64	28 1 7/64	19 3/4	48 1 7/8	23 2 9/32	67 2 41/64	61 2,4016	22 0,866	M20 3/4	59 000 36 600	UC310 UC310-29 UC310-30 UC310-31	F310	4,5	
UCF311 UCF311-32 UCF311-33 UCF311-34 UCF311-35	55 2 2 1/16 2 1/8 2 3/16	185 7 9/32	140 5 33/64	30 1 9/16	20 2 5/32	52 2 1/16	23 2 9/32	71 2 51/64	66 2,5984	25 0,948	M20 3/4	68 000 43 000	UC311 UC311-32 UC311-33 UC311-34 UC311-35	F311	5,5	
UCF312 UCF312-36 UCF312-37 UCF312-38 UCF312-39	60 2 1/4 2 5/16 2 3/8 2 7/16	195 7 11/16	150 5 29/32	33 1 19/64	22 7/8	56 2 7/32	23 2 9/32	78 3 5/64	71 2,7953	26 1,024	M20 3/4	78 000 49 500	UC312 UC312-36 UC312-37 UC312-38 UC312-39	F312	6,5	
UCF313 UCF313-40 UCF313-41	65 2 1/2 2 9/16	208 8 3/16	166 6 17/32	33 1 19/64	22 5 5/64	58 2 9/32	23 2 9/32	78 3 5/64	75 2,9528	30 1,818	M20 3/4	88 000 57 000	UC313 UC313-40 UC313-41	F313	7,9	
UCF314 UCF314-42 UCF314-43 UCF314-44	70 2 5/8 2 1/16 2 3/4	226 8 29/32	178 6 1/64	36 1 27/64	25 3 1/32	61 2 13/32	25 6 3/64	81 3 3/16	78 3,0708	33 1,299	M22 7/8	99 000 64 600	UC314 UC314-42 UC314-43 UC314-44	F314	9,5	
UCF315 UCF315-45 UCF315-46 UCF315-47 UCF315-48	75 2 13/16 2 7/8 2 15/16 3	236 9 19/32	184 7 1/4	39 1 17/32	25 3 1/32	66 2 19/32	25 6 3/64	89 3 1/2	82 3,2283	32 1,260	M22 7/8	108 000 73 500	UC315 UC315-45 UC315-46 UC315-47 UC315-48	F315	1,2	
UCF316 UCF316-49 UCF316-50 UCF316-51	80 3 1/8 3 1/8 3 3/16	250 9 27/32	196 7 23/32	38 1 1/2	27 1 1/16	68 2 11/16	31 1 7/32	90 3 35/64	86 3,3858	34 1,339	M27 1	117 000 83 000	UC316 UC316-49 UC316-50 UC316-51	F316	14	
UCF317 UCF317-52 UCF317-53 UCF317-55	85 3 3/4 3 5/16 3 7/16	260 10 1/4	204 8 1/32	44 1 47/64	27 1 1/16	74 2 29/32	31 1 7/32	100 3 15/16	96 3,7795	40 1,575	M27 1	127 000 93 000	UC317 UC317-52 UC317-53 UC317-55	F317	16	
UCF318 UCF318-55 UCF318-56	90 3 7/8 3 1/2	280 11 1/32	216 8 1/2	44 1 47/64	30 1 3/16	76 3	35 1 3/8	100 3 15/16	96 3,7795	40 1,575	M30 1 1/8	136 000 102 000	UC318 UC318-55 UC318-56	F318	19	
UCF319 UCF319-58 UCF319-59 UCF319-60	95 3 5/8 3 1/16 3 3/4	290 11 13/32	228 8 31/32	59 2 21/64	30 1 3/16	94 3 11/16	35 1 3/8	121 4 49/64	103 4,0551	41 1,614	M30 1 1/8	145 000 113 000	UC319 UC319-58 UC319-59 UC319-60	F319	22	
UCF320 UCF320-61 UCF320-62 UCF320-63 UCF320-64	100 3 13/16 3 7/8 3 15/16 4	310 12 7/32	242 9 17/32	59 2 21/64	32 1 1/4	94 3 11/16	38 1 1/2	125 4 59/64	108 4,2520	42 1,654	M33 1 1/4	165 000 134 000	UC320 UC320-61 UC320-62 UC320-63 UC320-64	F320	26	

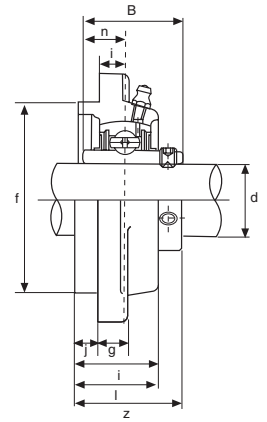
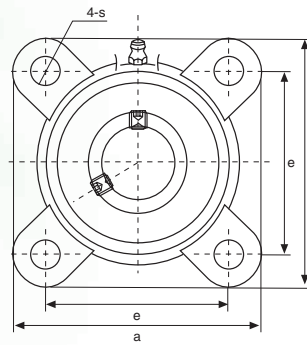

Tipo Type	Dimensioni mm/pollici Dimensions mm/inch												Bull. fiss. Bolt Size mm/inch	Coefficienti di carico (N) Load ratings (N)		Cuscinetto Bearing	Supporto Housing	Peso Weight (kg)
	d	a	e	i	s	j	g	l	f	z	B	n		Dinamico C Dynamic C	Statico C <sub>0</sub> Static C <sub>0</sub>			
UCFS305 UCFS305-13 UCFS305-14 UCFS305-15 UCFS305-16	25 1 1/16 7/8 15/16 1	110	80	9	16	7	13	29	80	39	38	15	M14 1/2	20 200	11 930	UC305 UC305-13 UC305-14 UC305-15 UC305-16	FS305	1,3
UCFS306 UCFS306-17 UCFS306-18 UCFS306-19	30 1 1/16 1 1/8 1 3/16	125	95	10	16	8	15	32	90	44	43	17	M14 1/2	25 400	14 300	UC306 UC306-17 UC306-18 UC306-19	FS306	1,9
UCFS307 UCFS307-20 UCFS307-21 UCFS307-22 UCFS307-23	35 1 1/4 1 5/16 1 3/8 1 7/16	135	100	11	19	9	16	36	100	49	48	19	M16 5/8	31 900	18 200	UC307 UC307-20 UC307-21 UC307-22 UC307-23	FS307	2,4
UCFS308 UCFS308-25 UCFS308-25	40 1 1/2 1 9/16	150	112	13	19	10	17	40	115	56	52	19	M16 5/8	38 500	23 000	UC308 UC308-24 UC308-25	FS308	3,3
UCFS309 UCFS309-26 UCFS309-27 UCFS309-28	45 1 3/8 1 11/16 1 3/4	160	125	14	19	11	18	44	125	60	57	22	M16 5/8	50 500	30 500	UC309 UC309-26 UC309-27 UC309-28	FS309	4,0
UCFS310 UCFS310-29 UCFS310-30 UCFS310-31	50 1 13/16 1 7/8 1 15/16	175	132	16	23	12	19	48	140	67	61	22	M20 3/4	59 000	36 600	UC310 UC310-29 UC310-30 UC310-31	FS310	5,3
UCFS311 UCFS311-32 UCFS311-33 UCFS311-34 UCFS311-35	55 2 2 1/16 2 1/8 2 3/16	185	140	17	23	13	20	52	150	71	66	26	M20 3/4	68 000	43 000	UC311 UC311-32 UC311-33 UC311-34 UC311-35	FS311	6,2
UCFS312 UCFS312-36 UCFS312-37 UCFS312-38 UCFS312-39	60 2 1/4 2 3/16 2 3/8 2 7/16	195	150	19	23	14	22	56	160	78	71	25	M20 3/4	78 000	49 500	UC312 UC312-36 UC312-37 UC312-38 UC312-39	FS312	7,2
UCFS313 UCFS313-40 UCFS313-41	65 2 1/2 2 9/16	208	166	15	23	18	22	58	175	78	75	30	M20 3/4	88 000	57 000	UC313 UC313-40 UC313-41	FS313	8,9
UCFS314 UCFS314-42 UCFS314-43 UCFS314-44	70 2 3/8 2 11/16 2 3/4	223	178	18	25	18	25	61	185	81	78	33	M20 7/8	99 000	64 600	UC314 UC314-42 UC314-43 UC314-44	FS314	11
UCFS315 UCFS315-45 UCFS315-46 UCFS315-47 UCFS315-48	75 2 13/16 2 7/8 2 15/16 3	236	184	21	25	18	25	66	200	89	82	32	M22 7/8	108 000	73 500	UC315 UC315-45 UC315-46 UC315-47 UC315-48	FS315	13
UCFS316 UCFS316-49 UCFS316-50 UCFS316-51	80 3 1/16 3 1/8 3 3/16	250	196	18	31	20	27	68	210	90	86	34	M27 1	117 000	83 000	UC316 UC316-49 UC316-50 UC316-51	FS316	15
UCFS317 UCFS317-52 UCFS317-53 UCFS317-55	85 3 1/4 3 5/16 3 7/16	260	204	24	31	20	27	74	220	100	96	40	M27 1	127 000	93 000	UC317 UC317-52 UC317-53 UC317-55	FS317	17
UCFS318 UCFS318-55 UCFS318-56	90 3 3/16 3 1/2	280	216	24	35	20	30	76	240	100	96	40	M30 1 1/8	136 000	102 000	UC318 UC318-55 UC318-56	FS318	21
UCFS319 UCFS319-58 UCFS319-59 UCFS319-60	95 3 5/8 3 11/16 3 3/4	280	228	39	35	20	30	94	250	121	103	41	M30 1 1/8	145 000	113 000	UC319 UC319-58 UC319-59 UC319-60	FS319	25
UCFS320 UCFS320-61 UCFS320-62 UCFS320-63 UCFS320-64	100 3 13/16 3 7/8 3 15/16 4	310	242	39	38	20	32	94	260	125	108	42	M33 1 1/4	165 000	134 000	UC320 UC320-61 UC320-62 UC320-63 UC320-64	FS320	30





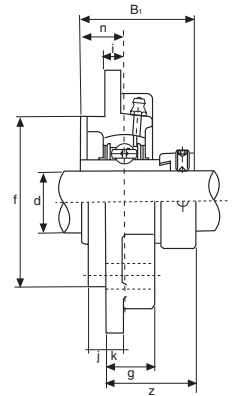
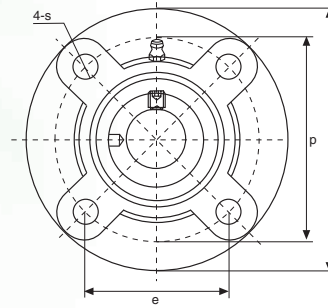

Tipo Type	Dimensioni mm/pollici Dimensions mm/inch													Bull. fiss. Bolt Size mm/inch	Coefficienti di carico (N) Load ratings (N)		Cuscinetto Bearing	Supporto Housing	Peso Weight (kg)
	d	a	p	e	i	s	j	k	g	f	z	B <sub>1</sub>	n		Dinamico C Dynamic C	Statico C <sub>0</sub> Static C <sub>0</sub>			
HCFC204 HCFC204-12	12 3/4	100 3 15/16	78 3 3/4	55,1 2 1/4	10 25/64	12 15/32	5 13/64	7 9/32	20,5 13/16	62 2,4409	36,6 1 7/16	43,7 1,720	17,1 0,673	M10 3/8	12 200	6 350	HC204 HC204-12	FC204	0,76 0,76
HCFC205 HCFC205-13 HCFC205-14 HCFC205-15 HCFC205-16	25 1 3/16 7/8 15/16 1	115 4 17/32	90 3 35/64	63,6 2 1/2	10 25/64	12 15/32	6 15/64	7 9/32	21 53/64	70 2,7559	36,9 1 29/64	44,4 1,748	17,5 0,689	M10 3/8	13 300	7 500	HC205 HC205-13 HC205-14 HC205-15 HC205-16	FC205	1,07 1,12 1,11 1,09 1,07
HCFC206 HCFC206-17 HCFC206-18 HCFC206-19 HCFC206-20	30 1 1/16 1 3/8 1 3/16 1 1/4	125 4 59/64	100 3 15/16	70,7 2 25/32	10 25/64	12 15/32	8 5/16	8 5/16	23 29/32	80 3,1496	40,1 1 37/64	48,4 1,906	18,3 0,720	M10 3/8	18 600	10 800	HC206 HC206-17 HC206-18 HC206-19 HC206-20	FC206	1,43 1,48 1,45 1,43 1,40
HCFC207 HCFC207-20 HCFC207-21 HCFC207-22 HCFC207-23	35 1 1/4 1 3/8 1 3/8 1 7/16	135 5 1/16	110 4 21/64	77,8 3 1/16	11 7/16	14 35/64	8 5/16	9 23/64	26 1 1/32	90 3,5433	43,3 1 45/64	51,1 2,012	18,8 0,740	M12 7/16	24 500	14 600	HC207 HC207-20 HC207-21 HC207-22 HC207-23	FC207	1,93 2,00 1,96 1,93 1,87
HCFC208 HCFC208-24 HCFC208-25	40 1 1/2 1 9/16	145 5 45/64	120 4 23/32	84,8 3 11/32	11 7/16	14 35/64	10 25/64	9 23/64	26 1 1/32	100 3,9370	45,9 1 13/16	56,3 2,217	21,4 0,843	M12 7/16	27 700	17 000	HC208 HC208-24 HC208-25	FC208	2,29 2,34 2,30
HCFC209 HCFC209-26 HCFC209-27 HCFC209-28	45 1 5/8 1 11/16 1 3/4	160 6 19/64	132 5 13/64	93,3 3 43/64	10 25/64	16 5/8	12 15/32	14 13/64	26 1 1/32	105 4,1339	44,9 1 49/64	56,3 2,217	21,4 0,843	M14 1/2	31 000	19 500	HC209 HC209-26 HC209-27 HC209-28	FC209	2,85 2,96 2,91 2,87
HCFC210 HCFC210-29 HCFC210-30 HCFC210-31 HCFC210-32	50 1 13/16 1 7/8 1 15/16 2	165 6 1/2	138 5 7/16	97,6 3 27/32	10 25/64	16 5/8	12 15/32	14 35/64	28 1 7/64	110 4,3307	48,1 1 57/64	62,7 2,469	24,6 0,969	M14 1/2	33 500	22 500	HC210 HC210-29 HC210-30 HC210-31 HC210-32	FC210	3,09 3,24 3,18 3,12 3,06
HCFC211 HCFC211-32 HCFC211-33 HCFC211-34 HCFC211-35	55 2 2 1/16 2 1/8 2 3/16	185 7 3/32	150 5 29/32	106,1 4 3/16	13 33/64	19 3/4	12 15/32	15 19/32	31 1 7/32	125 4,9213	56,6 2 15/64	71,4 2,811	27,8 1,094	M16 5/8	41 500	28 000	HC211 HC211-32 HC211-33 HC211-34 HC211-35	FC211	4,22 4,42 4,34 4,27 4,19
HCFC212 HCFC212-36 HCFC212-37 HCFC212-38 HCFC212-39	60 2 1/4 2 5/16 2 3/8 2 7/16	195 7 11/16	160 6 19/64	113,1 4 29/64	17 43/64	19 3/4	12 15/32	15 19/32	36 1 27/64	135 5,3150	63,8 2 39/64	77,8 3,063	31 1,220	M16 5/8	50 000	34 500	HC212 HC212-36 HC212-37 HC212-38 HC212-39	FC212	5,28 5,44 5,35 5,30 5,17
HCFC213 HCFC213-40 HCFC213-41	65 2 1/2 2 9/16	205 8 5/64	170 6 11/16	120,2 4 47/64	16 5/8	19 3/4	14 35/64	15 19/32	36 1 27/64	145 5,5118	67,6 2 21/32	85,7 3,374	34,1 1,343	M16 5/8	54 700	38 000	HC213 HC213-40 HC213-41	FC213	6,21 6,31 6,20
HCFC214 HCFC214-42 HCFC214-43 HCFC214-44	70 2 3/8 2 11/16 2 3/4	215 8 15/32	177 6 31/32	125,1 4 59/64	17 43/64	19 3/4	14 35/64	18 23/32	40 1 37/64	150 5,9055	68,6 2 45/64	85,7 3,374	34,1 1,343	M16 5/8	59 000	42 000	HC214 HC214-42 HC214-43 HC214-44	FC214	7,45 7,69 7,58 7,46
HCFC215 HCFC215-45 HCFC215-46 HCFC215-47 HCFC215-48	75 2 13/16 2 7/8 2 15/16 3	220 8 21/32	184 7 1/4	130,1 5 1/8	18 23/32	19 3/4	16 5/8	18 23/32	40 1 37/64	160 6,2992	72,8 2 7/8	92,1 3,626	37,3 1,469	M16 5/8	63 000	47 000	HC215 HC215-45 HC215-46 HC215-47 HC215-48	FC215	8,19 8,49 8,36 8,23 8,09



# SUPPORTI A FLANGIA TONDA CON BUSSOLA MONTATA FLANGE CARTRIDGE UNITS WITH ADAPTER SLEEVE MOUNTED



## UKFC2 Serie normale Normal Series

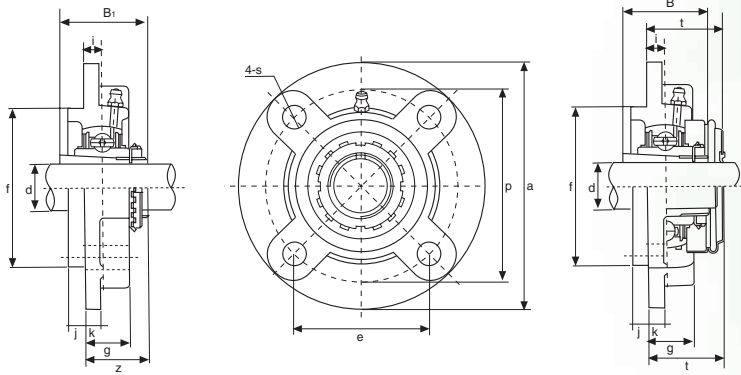

Tipo Type	Dimensioni mm/pollici Dimensions mm/inch													Bull. fiss. Bolt Size mm/inch	Coefficienti di carico (N) Load ratings (N)		Cuscinetto Bearing	Supporto Housing	Peso Weight (kg)
	d	a	p	e	i	s	j	k	g	f	z	t	B <sub>1</sub>		Dinamico C Dynamic C	Statico C <sub>0</sub> Static C <sub>0</sub>			
UKFC205+H2305 UKFC205+HE2305	20 3/4	115 4 17/32	90 3 39/64	63,6 2 1/2	10 15/64	12 15/32	6 15/64	7 9/32	21 53/64	70 2,7559	29,5 1 1/32	34 1 1/32	35 1,378	M10 3/8	13 500	7 500	UK205+H2305 UK205+HE2305	FC205	1,05
UKFC206+H2306 UKFC206+HS2306 UKFC206+HE2306	25 7/8 1	125 4 59/64	100 3 15/16	70,7 2 25/32	10 25/64	12 15/32	8 5/16	8 5/16	23 29/32	80 3,1496	31 1 7/32	36,5 1 7/16	38 1,496	M10 3/8	18 600	10 800	UK206+H2306 UK206+HS2306 UK206+HE2306	FC206	1,34
UKFC207+H2307 UKFC207+HS2307	30 1 1/8	135 5 1/16	110 4 21/64	77,8 3 1/16	11 7/16	14 35/64	8 5/16	9 23/64	26 1 1/32	90 3,5433	33,5 1 1/16	41 1 5/8	43 1,693	M12 7/16	24 500	14 600	UK207+H2307 UK207+HS2307	FC207	1,90
UKFC208+H2308 UKFC208+HE2308 UKFC208+HS2308	35 1 1/4 1 3/8	145 5 45/64	120 4 23/32	84,8 3 11/32	11 7/16	14 35/64	10 25/64	9 23/64	26 1 1/32	100 3,9370	35,5 1 25/64	45,5 1 5/8	46 1,811	M12 7/16	27 700	16 900	UK208+H2308 UK208+HE2308 UK208+HS2308	FC208	2,24
UKFC209+H2309 UKFC209+HA2309 UKFC209+HE2309 UKFC209+HS2309	40 1 7/16 1 1/2 1 5/8	160 6 1/8	132 5 19/64	93,3 3 43/64	10 25/64	16 5/8	12 15/32	14 35/64	26 1 1/32	105 4,1339	36 1 27/64	44,5 1 3/4	50 1,969	M14	31 000	19 400	UK209+H2309 UK209+HA2309 UK209+HE2309 UK209+HS2309	FC209	2,83
UKFC210+H2310 UKFC210+HS2310 UKFC210+HA2310 UKFC210+HE2310	45 1 3/8 1 11/16 1 3/4	165 6 1/2	138 5 7/16	97,6 3 27/32	10 25/64	16 5/8	12 15/32	14 35/64	28 1 1/8	110 4,3307	37,5 1 15/32	47,5 1 7/8	55 2,165	M14	33 300	22 000	UK210+H2310 UK210+HS2310 UK210+HA2310 UK210+HE2310	FC210	3,07
UKFC211+H2311 UKFC211+HS2311 UKFC211+HA2311 UKFC211+HE2311	50 1 7/8 1 15/16 2	185 7 3/32	150 5 29/32	106,1 4 3/16	13 33/64	19 3/4	12 15/32	15 19/32	31 1 7/32	125 4,9213	41,5 1 41/64	51 2 1/64	59 2,323	M16	41 400	27 800	UK211+H2311 UK211+HS2311 UK211+HA2311 UK211+HE2311	FC211	4,16
UKFC212+H2312 UKFC212+HS2312	55 2 1/8	195 7 11/16	160 6 19/64	113,1 4 29/64	17 43/64	19 3/4	12 15/32	15 19/32	36 1 27/64	135 5,3150	48 1 57/64	61,5 2 27/64	62 2,441	M16 5/8	49 900	34 200	UK212+H2312 UK212+HS2312	FC212	4,99
UKFC213+H2313 UKFC213+HA2313 UKFC213+HE2313 UKFC213+HS2313	60 2 3/16 2 1/4 2 5/8	205 8 1/8	170 6 11/16	120,2 4 47/64	16 5/8	19 3/4	14 35/64	15 19/32	36 1 27/64	145 5,5118	49 1 15/16	60,5 2 25/64	65 2,559	M16	54 700	38 000	UK213+H2313 UK213+HA2313 UK213+HE2313 UK213+HS2313	FC213	5,56
UKFC215+H2315 UKFC215+HA2315 UKFC215+HE2315	65 2 7/16 2 1/2	220 8 21/32	184 7 1/4	130,1 5 1/8	18 23/32	19 3/4	16 5/8	18 23/32	40 1 37/64	160 6,2992	53,5 2 1/64	-	73 2,874	M16	63 000	47 000	UK215+H2315 UK215+HA2315 UK215+HE2315	FC215	7,67
UKFC216+H2316 UKFC216+HA2316 UKFC216+HE2316	70 2 11/16 2 3/4	240 9 29/64	200 7 7/8	141,4 5 9/16	18 23/32	23 29/32	16 5/8	18 23/32	42 1 21/32	170 6,6929	57 2 1/4	-	78 3,071	M20 3/4	68 900	51 000	UK216+H2316 UK216+HA2316 UK216+HE2316	FC216	9,41
UKFC217+H2317 UKFC217+HA2317 UKFC217+HE2317	75 2 15/16 3	250 9 27/32	208 8 3/16	147,1 5 51/64	18 23/32	23 29/32	18 23/32	20 25/32	45 1 25/32	180 7,0866	59 2 21/64	-	82 3,228	M20 3/4	80 000	61 000	UK217+H2317 UK217+HA2317 UK217+HE2317	FC217	11,23
UKFC218+H2318 UKFC218+HA2318	80 3 3/16	265 10 7/16	220 8 21/32	155,5 6 1/8	22 55/64	23 29/32	18 23/32	20 25/32	50 1 31/32	190 7,4803	64,5 3 35/64	-	86 3,386	M20 3/4	91 200	68 000	UK218+H2318 UK218+HA2318	FC218	13,34

Bussole HA; HE; HS con filettatura in pollici  
Inch dimension adapter sleeves HA; HE; HS

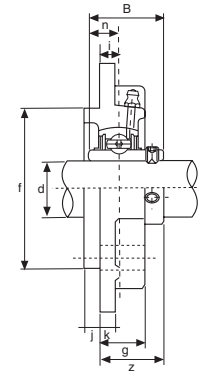
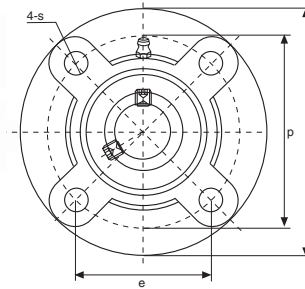

Tipo Type	Dimensioni mm/pollici Dimensions mm/inch													Bull. fiss. Bolt Size mm/inch	Coefficienti di carico (N) Load ratings (N)		Cuscinetto Bearing	Supporto Housing	Peso Weight (kg)															
	d	a	p	e	i	s	j	k	g	f	z	B	n		Dinamico C Dynamic C	Statico C <sub>0</sub> Static C <sub>0</sub>																		
UCFCX05 UCFCX05-13 UCFCX05-14 UCFCX05-15 UCFCX05-16	25 1 9/16 7/8 1 9/16 1	111	92	65	10	9,5	6	9,5	24	76	32,2	38,1	15,9	M8	18 600	10 800	UCX05 UCX05-13 UCX05-14 UCX05-15 UCX05-16	FCX05	1,2															
UCFCX06 UCFCX06-17 UCFCX06-18 UCFCX06-19 UCFCX06-20	30 1 1/16 1 1/8 1 3/16 1 1/4	127	105	74,2	8	12	9,5	9,5	22,5	85	33,4	42,9	17,5	M10						24 500	14 600	UCX06 UCX06-17 UCX06-18 UCX06-19 UCX06-20	FCX06	1,5										
UCFCX07 UCFCX07-21 UCFCX07-22 UCFCX07-23	35 1 5/16 1 7/8 1 7/16	133	111	78,5	9	12	11	11	26	92	39,2	49,2	19	M10											27 700	17 000	UCX07 UCX07-21 UCX07-22 UCX07-23	FCX07	1,9					
UCFCX08 UCFCX08-24 UCFCX08-25	40 1 1/2 1 9/16	133	111	78,5	9	12	11	11	26	92	39,2	49,2	19	M10																30 900	19 400	UCX08 UCX08-24 UCX08-25	FCX08	2,0
UCFCX09 UCFCX09-26 UCFCX09-27 UCFCX09-28 UCFCX09-29	45 1 5/8 1 11/16 1 3/4 1 13/16	155	130	91,9	8	14	12	11	25	108	40,6	51,6	19	M12																				
UCFCX10 UCFCX10-30 UCFCX10-31 UCFCX10-32	50 1 7/8 1 15/16 2	162	136	96,2	7	14	16	11	25	118	40,4	55,6	22,2	M12	41 400	27 800	UCX10 UCX10-30 UCX10-31 UCX10-32	FCX10	3,2															
UCFCX11 UCFCX11-33 UCFCX11-34 UCFCX11-35 UCFCX11-36 UCFCX11-37	55 2 1/16 2 1/8 2 3/16 2 1/4 2 5/16	180	152	107,5	4	16	22	13	26	127	43,7	65,1	25,4	M14						49 900	34 200	UCX11 UCX11-33 UCX11-34 UCX11-35 UCX11-36 UCX11-37	FCX11	4,3										
UCFCX12 UCFCX12-38 UCFCX12-39	60 2 3/8 2 7/16	194	165	116,7	11	16	20	14	33	140	50,7	65,1	25,4	M14											54 700	38 000	UCX12 UCX12-38 UCX12-39	FCX12	5,3					
UCFCX13 UCFCX13-40 UCFCX13-41	65 2 1/2 2 9/16	194	165	116,7	11	16	20	14	33	140	55,4	74,6	30,2	M14																58 900	41 800	UCX13 UCX13-40 UCX13-41	FCX13	5,7
UCFCX14 UCFCX14-42 UCFCX14-43 UCFCX14-44	70 2 5/8 2 1/16 2 3/4	222	190	134,3	14	19	20	14	36	164	58,5	77,8	33,3	M16																				
UCFCX15 UCFCX15-45 UCFCX15-46 UCFCX15-47 UCFCX15-48	75 2 13/16 2 7/8 2 15/16 3	222	190	134,3	12	19	22	16	35	164	61,3	82,6	33,3	M16	68 900	50 500	UCX15 UCX15-45 UCX15-46 UCX15-47 UCX15-48	FCX15	8															
UCFCX16 UCFCX16-49 UCFCX16-50 UCFCX16-51 UCFCX16-52	80 3 1/16 3 1/8 3 3/16 3 1/4	260	219	154,8	10	23	25	19	36	186	61,6	85,7	34,1	M20						79 400	61 000	UCX16 UCX16-49 UCX16-50 UCX16-51 UCX16-52	FCX16	11,3										
UCFCX17 UCFCX17-53 UCFCX17-55	85 3 5/16 3 7/16	260	219	154,8	10	23	25	19	36	186	66,3	96	39,7	M20											91 500	68 000	UCX17 UCX17-53 UCX17-55	FCX17	12,9					
UCFCX18 UCFCX18-56 UCFCX18-57	90 3 7/16 3 1/2	260	219	154,8	12	23	28	-	43	186	73,1	104	42,9	M20																104 000	80 000	UCX18 UCX18-56 UCX18-57	FCX18	12
UCFCX20 UCFCX20-58 UCFCX20-59 UCFCX20-60 UCFCX20-61	100 3 13/16 3 7/8 3 15/16 4	276	238	168,3	22	23	28	-	66	206	90,3	117,5	49,2	M20																				



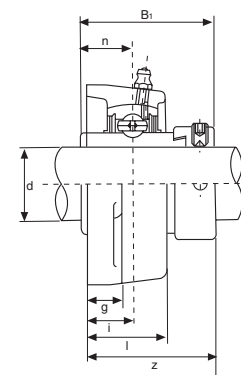
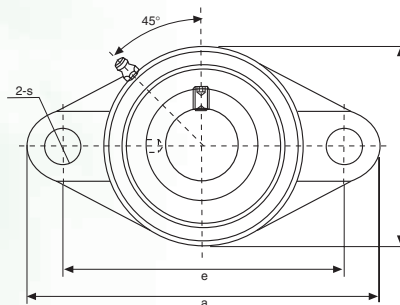

Tipo Type	Dimensioni mm/pollici Dimensions mm/inch											Bull. fiss. Bolt Size mm/inch	Coefficienti di carico (N) Load ratings (N)		Cuscinetto Bearing	Supporto Housing	Peso Weight (kg)
	d	a	e	i	g	l	s	b	z	B <sub>1</sub>	n		Dinamico C Dynamic C	Statico C <sub>0</sub> Static C <sub>0</sub>			
HCFL204 HCFL204-12	20 3/4	113 4 7/16	90 3 35/64	15 1 9/32	11 7/16	25,5 1	12 1 5/32	60 2 3/8	41,6 1 41/64	43,7 1,720	17,1 0,673	M10 3/8	12 200	6 350	HC204 HC204-12	FL204	0,48 0,48
HCFL205 HCFL205-13 HCFL205-14 HCFL205-15 HCFL205-16	25 1 3/16 7/8 1 5/16 1	130 5 1/8	99 3 57/64	16 5/8	13 1/2	27 1 1/16	16 5/8	68 2 11/16	42,9 1 11/16	44,4 1,748	17,5 0,689	M14 1/2	13 300	7 500	HC205 HC205-13 HC205-14 HC205-15 HC205-16	FL205	0,65 0,70 0,69 0,67 0,65
HCFL206 HCFL206-17 HCFL206-18 HCFL206-19 HCFL206-20	30 1 1/4 1 3/8 1 3/16 1 1/4	148 5 3/16	117 4 39/64	18 4 5/64	13 1/2	31 1 7/32	16 5/8	80 3 3/32	48,1 1 57/64	48,4 1,906	18,3 0,720	M14 1/2	18 600	10 800	HC206 HC206-17 HC206-18 HC206-19 HC206-20	FL206	0,99 1,04 1,01 0,99 0,96
HCFL207 HCFL207-20 HCFL207-21 HCFL207-22 HCFL207-23	35 1 1/4 1 5/16 1 3/8 1 7/16	161 6 11/32	130 5 1/8	19 3/4	14 3 5/64	34 1 11/32	16 5/8	90 3 35/64	51,3 2 1/64	51,1 2,012	18,8 0,740	M14 1/2	24 500	14 600	HC207 HC207-20 HC207-21 HC207-22 HC207-23	FL207	1,20 1,27 1,23 1,20 1,17
HCFL208 HCFL208-24 HCFL208-25	40 1 1/2 1 9/16	175 6 7/8	144 5 43/64	21 5 3/64	14 3 5/64	36 1 11/32	16 5/8	100 3 15/16	55,9 2 13/64	56,3 2,217	21,4 0,843	M14 1/2	27 700	17 000	HC208 HC208-24 HC208-25	FL208	1,59 1,64 1,60
HCFL209 HCFL209-26 HCFL209-27 HCFL209-28	45 1 5/8 1 11/16 1 3/4	188 7 13/32	148 5 53/64	22 5 5/64	15 1 9/32	38 1 1/2	19 3/4	108 4 1/4	56,9 2 15/64	56,3 2,217	21,4 0,843	M16 5/8	31 000	19 500	HC209 HC209-26 HC209-27 HC209-28	FL209	1,91 2,02 1,97 1,93
HCFL210 HCFL210-29 HCFL210-30 HCFL210-31 HCFL210-32	50 1 13/16 1 7/8 1 15/16 2	197 7 7/4	157 6 3/16	22 5 5/64	15 1 9/32	40 1 37/64	19 3/4	115 4 17/32	60,1 2 23/64	62,7 2,469	24,6 0,969	M16 5/8	33 500	22 500	HC210 HC210-29 HC210-30 HC210-31 HC210-32	FL210	2,29 2,44 2,38 2,32 2,26
HCFL211 HCFL211-32 HCFL211-33 HCFL211-34 HCFL211-35	55 2 2 1/8 2 1/8 2 3/16	224 8 13/16	184 7 1/4	25 6 3/64	18 2 3/32	43 1 11/16	19 3/4	130 5 1/8	68,6 2 45/64	71,4 2,811	27,8 1,094	M16 5/8	41 500	28 000	HC211 HC211-32 HC211-33 HC211-34 HC211-35	FL211	3,12 3,32 3,24 3,17 3,09
HCFL212 HCFL212-36 HCFL212-37 HCFL212-38 HCFL212-39	60 2 4/4 2 5/16 2 3/8 2 7/16	250 9 27/32	202 7 61/64	29 1 9/64	18 2 3/32	48 1 7/8	23 2 9/32	140 5 1/2	75,8 2 63/64	77,8 3,063	31 1,220	M20 3/4	50 000	34 500	HC212 HC212-36 HC212-37 HC212-38 HC212-39	FL212	4,08 4,24 4,15 4,10 3,97
HCFL213 HCFL213-40 HCFL213-41	65 2 1/2 2 9/16	258 10 9/32	210 8 17/64	30 1 3/16	22 7/8	50 1 31/32	23 2 9/32	155 6 3/32	81,6 3 7/32	85,7 3,374	34,1 1,343	M20 3/4	54 700	38 000	HC213 HC213-40 HC213-41	FL213	5,13 5,23 5,12
HCFL214 HCFL214-42 HCFL214-43 HCFL214-44	70 2 3/8 2 11/16 2 3/4	265 10 7/16	216 8 1/2	31 1 7/32	22 7/8	54 2 1/8	23 2 9/32	160 6 5/16	82,6 3 1/4	85,7 3,374	34,1 1,343	M20 3/4	59 000	42 000	HC214 HC214-42 HC214-43 HC214-44	FL214	5,61 5,85 5,74 5,62
HCFL215 HCFL215-45 HCFL215-46 HCFL215-47 HCFL215-48	75 2 13/16 2 7/8 2 15/16 3	275 10 13/16	225 8 55/64	34 1 11/32	22 7/8	56 2 7/32	23 2 9/32	165 6 1/2	88,8 3 1/2	92,1 3,626	37,3 1,426	M20 3/4	63 000	47 000	HC215 HC215-45 HC215-46 HC215-47 HC215-48	FL215	6,00 6,30 6,17 6,04 5,90



**SUPPORTI A FLANGIA OVALE CON BUSSOLA MONTATA**  
**OVAL FLANGE UNITS WITH ADAPTER SLEEVE MOUNTED**



**UKFL2 Serie normale Normal Series**

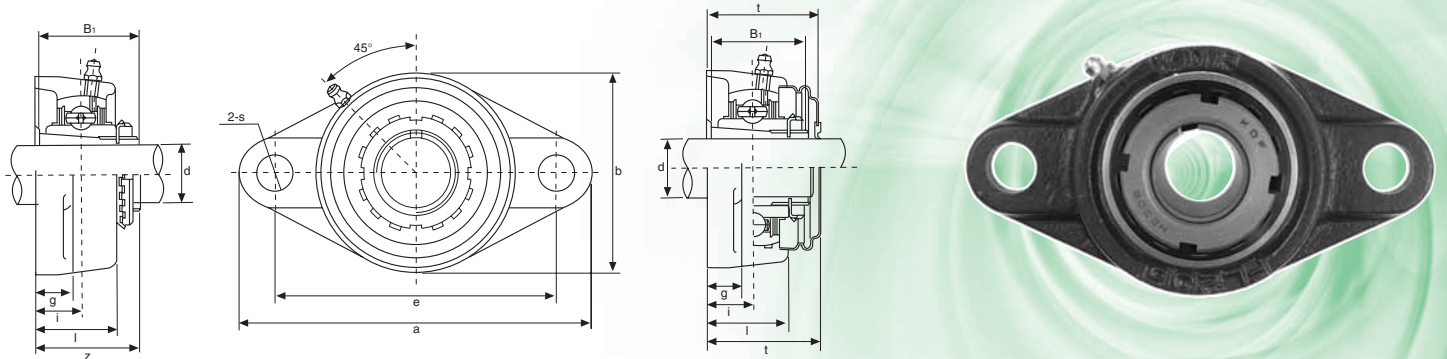

Tipo Type	Dimensioni mm/pollici Dimensions mm/inch											Bull. fiss. Bolt Size mm/inch	Coefficients di carico (N) Load ratings (N)		Cuscinetto Bearing	Supporto Housing	Peso Weight (kg)
	d	a	e	i	g	l	s	b	z	t	B <sub>1</sub>		Dinamico C Dynamic C	Statico C <sub>0</sub> Static C <sub>0</sub>			
UKFL205+H2305 UKFL205+HE2305	20 ¾	130 5 1/8	99 3 57/64	16 5/8	13 ½	27 1 1/16	16 5/8	68 2 11/16	35,5 1 29/64	40 1 9/16	35 1,378	M14 ½	13 500	7 500	UK205+H2305 UK205+HE2305	FL205	0,63
UKFL206+H2306 UKFL206+HS2306 UKFL206+HE2306	25 7/8 1	148 5 13/16	117 4 39/64	18 45/64	13 ½	31 1 7/32	16 5/8	80 3 3/32	39 1 17/32	44,5 1 ¾	38 1,496	M14 ½	18 600	10 800	UK206+H2306 UK206+HS2306 UK206+HE2306	FL206	0,90
UKFL207+H2307 UKFL207+HS2307	30 1 1/8	161 6 11/32	130 5 1/8	19 ¾	14 35/64	34 1 11/32	16 5/8	90 3 35/64	42,5 1 43/64	48,5 1 29/32	43 1,693	M14 ½	24 500	14 600	UK207+H2307 UK207+HS2307	FL207	1,17
UKFL208+H2308 UKFL208+HE2308 UKFL208+HS2308	35 1 1/4 1 3/8	175 6 7/8	144 5 43/64	21 53/64	14 35/64	36 1 11/32	16 5/8	100 3 15/16	46,5 1 53/64	55,5 2 1/16	46 1,811	M14 ½	27 700	16 900	UK208+H2308 UK208+HE2308 UK208+HS2308	FL208	1,54
UKFL209+H2309 UKFL209+HA2309 UKFL209+HE2309 UKFL209+HS2309	40 1 7/16 1 1/2 1 5/8	188 7 13/32	148 5 53/64	22 55/64	15 1 9/32	38 1 1/2	19 ¾	108 4 1/4	48,5 1 29/32	56,5 2 1/32	50 1,969	M16 5/8	31 000	19 400	UK209+H2309 UK209+HA2309 UK209+HE2309 UK209+HS2309	FL209	1,89
UKFL210+H2310 UKFL210+HS2310 UKFL210+HA2310 UKFL210+HE2310	45 1 3/8 1 11/16 1 3/4	197 7 3/4	157 6 3/16	22 55/64	15 1 9/32	40 1 37/64	19 ¾	115 4 17/32	50 1 31/32	59,5 2 11/32	55 2,165	M16 5/8	33 300	22 000	UK210+H2310 UK210+HS2310 UK210+HA2310 UK210+HE2310	FL210	2,27
UKFL211+H2311 UKFL211+HS2311 UKFL211+HA2311 UKFL211+HE2311	50 1 7/8 1 15/16 2	224 8 13/16	184 7 1/4	25 63/64	18 23/32	43 1 11/16	19 ¾	130 5 1/8	54,5 2 9/64	63 2 15/32	59 2,323	M16 5/8	41 400	27 800	UK211+H2311 UK211+HS2311 UK211+HA2311 UK211+HE2311	FL211	3,06
UKFL212+H2312 UKFL212+HS2312	55 2 1/8	250 9 27/32	202 7 51/64	29 1 9/64	18 23/32	48 1 7/8	23 29/32	140 5 1/2	61 2 13/32	73,5 2 57/64	62 2,441	M20 ¾	49 900	34 200	UK212+H2312 UK212+HS2312	FL212	3,79
UKFL213+H2313 UKFL213+HA2313 UKFL213+HE2313 UKFL213+HS2313	60 2 3/16 2 1/4 2 3/8	258 10 9/32	210 8 17/64	30 1 3/16	22 7/8	50 1 31/32	23 29/32	155 6 3/32	64 2 33/64	74,5 2 51/16	65 2,559	M20 ¾	54 700	38 000	UK213+H2313 UK213+HA2313 UK213+HE2313 UK213+HS2313	FL213	4,48
UKFL215+H2315 UKFL215+HA2315 UKFL215+HE2315	65 2 7/16 2 1/2	275 10 13/16	225 8 55/64	34 1 11/32	22 7/8	56 2 1/32	23 29/32	165 6 1/2	71 2 51/64	-	73 2,874	M20 ¾	63 000	47 000	UK215+H2315 UK215+HA2315 UK215+HE2315	FL215	5,48
UKFL216+H2316 UKFL216+HA2316 UKFL216+HE2316	70 2 11/16 2 3/4	290 11 13/32	233 9 11/64	34 1 11/32	22 7/8	58 2 9/32	25 63/64	180 7 3/32	73,5 2 57/64	-	78 3,071	M22 7/8	68 900	51 000	UK216+H2316 UK216+HA2316 UK216+HE2316	FL216	7,46
UKFL217+H2317 UKFL217+HA2317 UKFL217+HE2317	75 2 15/16 3	305 12	248 9 49/64	36 1 27/64	24 1 5/16	63 2 15/32	25 63/64	190 7 15/32	77 3 1/32	-	82 3,228	M22 7/8	80 000	61 000	UK217+H2317 UK217+HA2317 UK217+HE2317	FL217	9,03
UKFL218+H2318 UKFL218+HA2318	80 3 3/16	320 12 19/32	265 10 7/16	40 1 37/64	24 1 5/16	68 2 11/16	25 63/64	205 8 1/16	81,5 3 13/64	-	86 3,386	M22 7/8	91 200	68 000	UK218+H2318 UK218+HA2318	FL218	10,89

Bussole HA; HE; HS con filettatura in pollici  
 Inch dimension adapter sleeves HA; HE; HS

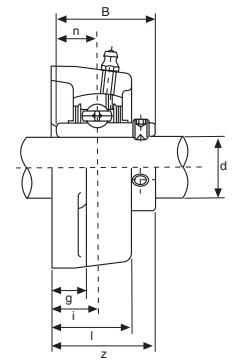
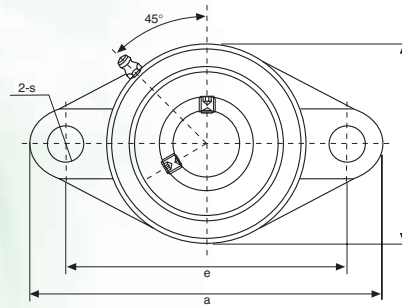

Tipo Type	Dimensioni mm/pollici Dimensions mm/inch											Bull. fiss. Bolt Size mm/inch	Coefficienti di carico (N) Load ratings (N)		Cuscinetto Bearing	Supporto Housing	Peso Weight (kg)															
	d	a	e	i	g	l	s	b	z	B	n		Dinamico C Dynamic C	Statico C <sub>0</sub> Static C <sub>0</sub>																		
UCFLX05 UCFLX05-13 UCFLX05-14 UCFLX05-15 UCFLX05-16	25 1 3/4 7/8 1 5/16 1	141	117	18	13	30	12	83	40,2	38,1	15,9	M10	18 600	10 800	UCX05 UCX05-13 UCX05-14 UCX05-15 UCX05-16	FLX05	1,0															
UCFLX06 UCFLX06-17 UCFLX06-18 UCFLX06-19 UCFLX06-20	30 1 1/16 1 1/8 1 3/16 1 1/4	156	130	19	15	34	16	95	44,4	42,9	17,5	M14						24 500	14 600	UCX06 UCX06-17 UCX06-18 UCX06-19 UCX06-20	FLX06	1,5										
UCFLX07 UCFLX07-21 UCFLX07-22 UCFLX07-23	35 1 5/16 1 3/8 1 7/16	171	144	21	16	38	16	105	51,2	49,2	19	M14											27 700	17 000	UCX07 UCX07-21 UCX07-22 UCX07-23	FLX07	2,0					
UCFLX08 UCFLX08-24 UCFLX08-25	40 1 1/2 1 9/16	179	148	22	16	40	16	111	52,2	49,2	19	M14																30 900	19 400	UCX08 UCX08-24 UCX08-25	FLX08	2,2
UCFLX09 UCFLX09-26 UCFLX09-27 UCFLX09-28 UCFLX09-29	45 1 5/8 1 11/16 1 3/4 1 13/16	89	157	23	16	40	16	116	55,6	51,6	19	M14																				
UCFLX10 UCFLX10-30 UCFLX10-31 UCFLX10-32	50 1 7/8 1 15/16 2	216	184	26	18	44	19	133	59,4	55,6	22,2	M16	41 400	27 800	UCX10 UCX10-30 UCX10-31 UCX10-32	FLX10	3,4															





# SUPPORTI A FLANGIA OVALE OVAL FLANGE UNITS

# KDF®

## UCFL3 Serie pesante *Heavy Series*

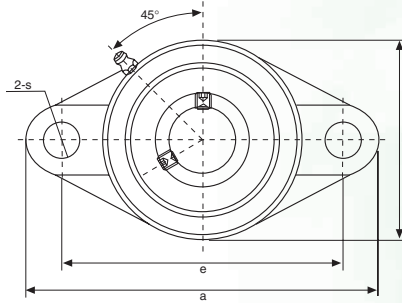
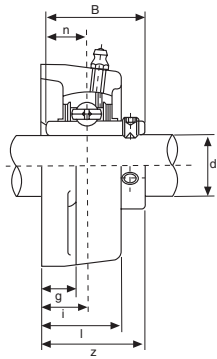

Tipo Type	Dimensioni mm/pollici Dimensions mm/inch											Bull. fiss. Bolt Size mm/inch	Coefficienti di carico (N) Load ratings (N)		Cuscinetto Bearing	Supporto Housing	Peso Weight (kg)
	d	a	e	i	g	l	s	b	z	B	n		Dinamico C Dynamic C	Statico C <sub>0</sub> Static C <sub>0</sub>			
UCFL305 UCFL305-13 UCFL305-14 UCFL305-15 UCFL305-16	25 1 1/16 7/8 19/16 1	150	113	16	13	29	19	80	39	38	15	M16 5/8	20 200	11 930	UC305 UC305-13 UC305-14 UC305-15 UC305-16	FL305	1,1
UCFL306 UCFL306-17 UCFL306-18 UCFL306-19	30 1 1/8 1 1/8 1 3/16	180	134	18	15	32	23	90	44	43	17	M20 3/4	25 400	14 300	UC306 UC305-17 UC305-18 UC305-19	FL306	1,5
UCFL307 UCFL307-20 UCFL307-21 UCFL307-22 UCFL307-23	35 1 1/4 1 5/16 1 9/8 1 7/16	185	141	20	16	36	23	100	49	48	19	M20 3/4	31 900	18 200	UC307 UC307-20 UC307-21 UC307-22 UC307-23	FL307	1,9
UCFL308 UCFL308-24 UCFL308-25	40 1 1/2 1 9/16	200	158	23	17	40	23	112	56	52	19	M20 3/4	38 500	23 000	UC308 UC308-24 UC308-25	FL308	2,5
UCFL309 UCFL309-26 UCFL309-27 UCFL309-28	45 1 5/8 1 11/16 1 3/4	230	177	25	18	44	25	125	60	57	22	M22 7/8	50 500	30 500	UC309 UC309-26 UC309-27 UC309-28	FL309	3,4
UCFL310 UCFL310-29 UCFL310-30 UCFL310-31	50 1 13/16 1 7/8 1 15/16	240	187	28	19	48	25	140	67	61	22	M22 7/8	59 000	36 600	UC310 UC310-29 UC310-30 UC310-31	FL310	4,4
UCFL311 UCFL311-32 UCFL311-33 UCFL311-34 UCFL311-35	55 2 2 1/16 2 1/8 2 3/16	250	198	30	20	52	25	150	71	66	25	M22 7/8	68 000	43 000	UC311 UC311-32 UC311-33 UC311-34 UC311-35	FL311	5,1
UCFL312 UCFL312-36 UCFL312-37 UCFL312-38 UCFL312-39	60 2 1/4 2 5/16 2 3/8 2 7/16	270	212	33	22	56	31	160	78	71	26	M27 1	78 000	49 500	UC312 UC312-36 UC312-37 UC312-38 UC312-39	FL312	6,1
UCFL313 UCFL313-40 UCFL313-41	65 2 1/2 2 9/16	295	240	33	25	58	31	175	78	75	30	M27 1	88 000	57 000	UC313 UC313-40 UC313-41	FL313	7,8
UCFL314 UCFL314-42 UCFL314-43 UCFL314-44	70 2 5/8 2 11/16 2 3/4	315	250	36	28	61	35	185	81	78	33	M20 1 1/8	99 000	64 600	UC314 UC314-42 UC314-43 UC314-44	FL314	9,0
UCFL315 UCFL315-45 UCFL315-46 UCFL315-47 UCFL315-48	75 2 13/16 2 7/8 2 15/16 3	320	260	39	30	66	35	195	89	82	32	M30 1 1/8	108 000	73 500	UC315 UC315-45 UC315-46 UC315-47 UC315-48	FL315	10
UCFL316 UCFL316-49 UCFL316-50 UCFL316-51	80 3 1/16 3 3/8 3 3/16	355	285	38	32	68	38	210	90	86	34	M33 1 1/4	117 000	83 000	UC316 UC316-49 UC316-50 UC316-51	FL316	13
UCFL317 UCFL317-52 UCFL317-53 UCFL317-55	85 3 1/4 3 5/16 3 7/16	370	300	44	32	74	38	220	100	96	40	M33 1 1/4	127 000	93 000	UC317 UC317-52 UC317-53 UC317-55	FL317	15
UCFL318 UCFL318-55 UCFL318-56	90 3 3/16 3 1/2	385	315	44	36	76	38	235	100	96	40	M33 1 1/4	136 000	102 000	UC318 UC318-55 UC318-56	FL318	18
UCFL319 UCFL319-58 UCFL319-59 UCFL319-60	95 3 5/8 3 11/16 3 3/4	405	330	59	40	94	41	250	121	103	41	M36 1 3/8	145 000	113 000	UC319 UC319-58 UC319-59 UC319-60	FL319	22
UCFL320 UCFL320-61 UCFL320-62 UCFL320-63 UCFL320-64	100 3 15/16 3 7/8 3 15/16 4	440	360	59	40	94	44	270	125	108	42	M39 1 1/2	165 000	134 000	UC320 UC320-61 UC320-62 UC320-63 UC320-64	FL320	27





**HCT2 Serie normale** *Normal Series*

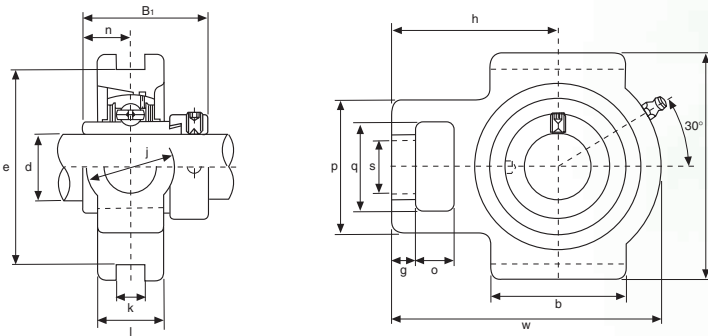

Tipo Type	Dimensioni mm/pollici Dimensions mm/inch																Coefficients di carico (N) Load ratings (N)		Cuscinetto Bearing	Supporto Housing	Peso Weight (kg)
	d	o	g	p	q	s	b	k	e	a	w	j	i	h	B <sub>1</sub>	n	Dinamico C Dynamic C	Statico C <sub>0</sub> Static C <sub>0</sub>			
HCT204 HCT204-12	20 3/4	16 5/8	10 29/64	51 1 1/16	32 1 1/4	19 3/4	51 2 1/64	12 15/32	76 2 53/64	89 3 1/2	94 3 11/16	32 1 1/4	24 1 5/16	61 2 13/32	43,7 1,720	17,1 0,673	12 200	6 350	HC204 HC204-12	T204	0,83 0,83
HCT205 HCT205-13 HCT205-14 HCT205-15 HCT205-16	25 1 3/16 7/8 15/16 1	16 5/8	10 29/64	51 1 1/16	32 1 1/4	19 3/4	51 2 1/64	12 15/32	76 2 53/64	89 3 1/2	97 3 13/16	32 1 1/4	24 1 5/16	62 2 7/16	44,4 1,748	17,5 0,689	13 300	7 500	HC205 HC205-13 HC205-14 HC205-15 HC205-16	T205	0,88 0,93 0,92 0,90 0,88
HCT206 HCT206-17 HCT206-18 HCT206-19 HCT206-20	30 1 1/16 1 1/8 1 3/16 1 1/4	16 5/8	10 29/64	56 2 7/32	37 1 29/64	22 55/64	57 2 1/4	12 15/32	89 3 1/2	102 4 1/64	113 4 29/64	37 4 29/64	28 1 3/32	70 2 3/4	48,4 1,906	18,3 0,720	18 600	10 800	HC206 HC206-17 HC206-18 HC206-19 HC206-20	T206	1,35 1,40 1,37 1,35 1,32
HCT207 HCT207-20 HCT207-21 HCT207-22 HCT207-23	35 1 1/4 1 5/16 1 3/8 1 7/16	16 5/8	13 33/64	64 2 33/64	37 1 29/64	22 55/64	64 2 33/64	12 15/32	89 3 1/2	102 4 1/64	129 5 5/64	37 1 29/64	30 1 3/16	78 3 5/64	51,1 2,012	18,8 0,740	24 500	14 600	HC207 HC207-20 HC207-21 HC207-22 HC207-23	T207	1,56 1,63 1,59 1,56 1,53
HCT208 HCT208-24 HCT208-25	40 1 1/2 1 9/16	19 3/4	16 5/8	83 3 17/64	49 1 15/16	29 1 9/64	83 3 17/64	16 5/8	102 4 1/64	114 4 31/64	144 4 43/64	49 1 15/16	35 1 3/8	89 3 1/2	56,3 2,217	21,4 0,843	27 700	17 000	HC208 HC208-24 HC208-25	T208	2,55 2,60 2,56
HCT209 HCT209-26 HCT209-27 HCT209-28	45 1 5/8 1 11/16 1 3/4	19 3/4	16 5/8	83 3 17/64	49 1 15/16	29 1 9/64	83 3 17/64	16 5/8	102 4 1/64	117 4 39/64	144 5 43/64	49 1 15/16	35 1 3/8	87 3 27/64	56,3 2,217	21,4 0,843	31 000	19 500	HC209 HC209-26 HC209-27 HC209-28	T209	2,53 2,64 2,59 2,55
HCT210 HCT210-29 HCT210-30 HCT210-31 HCT210-32	50 1 13/16 1 7/8 1 15/16 2	19 3/4	16 5/8	83 3 17/64	49 1 15/16	29 1 9/64	86 3 25/64	16 5/8	102 4 1/64	117 4 39/64	149 5 55/64	49 1 15/16	35 1 3/8	90 3 35/64	6,7 2,469	24,6 0,969	33 500	22 500	HC210 HC210-29 HC210-30 HC210-31 HC210-32	T210	2,62 2,77 2,71 2,65 2,59
HCT211 HCT211-32 HCT211-33 HCT211-34 HCT211-35	55 2 2 1/16 2 1/8 2 3/16	25 53/64	19 3/4	102 4 1/64	64 2 1/32	35 1 3/8	95 3 3/4	22 55/64	130 5 1/8	146 5 3/4	171 6 47/64	64 2 33/64	41 1 5/8	106 4 11/64	71,4 2,811	27,8 1,094	41 500	28 000	HC211 HC211-32 HC211-33 HC211-34 HC211-35	T211	4,32 4,52 4,44 4,37 4,29
HCT212 HCT212-36 HCT212-37 HCT212-38 HCT212-39	60 2 1/4 2 5/16 2 3/8 2 7/16	32 1 17/64	19 3/4	102 4 1/64	64 2 1/32	35 1 3/8	102 4 1/64	22 55/64	130 5 1/8	146 5 3/4	194 7 41/64	64 2 33/64	46 1 13/16	119 4 11/16	77,8 3,063	31 1,220	50 000	34 500	HC212 HC212-36 HC212-37 HC212-38 HC212-39	T212	5,31 5,47 5,38 5,33 5,20
HCT213 HCT213-40 HCT213-41	65 2 1/2 2 9/16	32 1 17/64	21 53/64	111 4 3/8	70 2 3/4	41 1 39/64	121 4 49/64	26 1 1/32	151 5 15/16	167 6 37/64	224 8 13/16	70 2 3/4	51 2	137 5 25/64	85,7 3,374	34,1 1,343	54 700	38 000	HC213 HC213-40 HC213-41	T213	7,21 7,31 7,20
HCT214 HCT214-42 HCT214-43 HCT214-44	70 2 3/8 2 11/16 2 3/4	32 1 17/64	21 53/64	111 4 3/8	70 2 3/4	41 1 39/64	121 4 49/64	26 1 1/32	151 5 15/16	167 6 37/64	224 8 13/16	70 2 3/4	46 1 13/16	137 5 25/64	85,7 3,374	34,1 1,343	59 000	42 000	HC214 HC214-42 HC214-43 HC214-44	T214	7,55 7,79 7,68 7,56
HCT215 HCT215-45 HCT215-46 HCT215-47 HCT215-48	75 2 13/16 2 7/8 2 15/16 3	32 1 17/64	21 53/64	111 4 3/8	70 2 3/4	41 1 39/64	121 4 49/64	26 1 1/32	151 5 15/16	167 6 37/64	232 9 9/64	70 2 3/4	48 1 57/64	140 5 33/64	92,1 3,626	37,3 1,426	63 000	47 000	HC215 HC215-45 HC215-46 HC215-47 HC215-48	T215	8,04 8,34 8,21 8,08 7,94

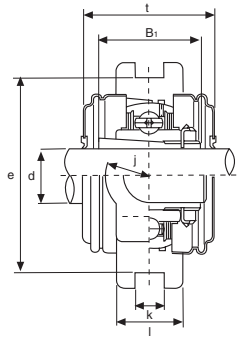
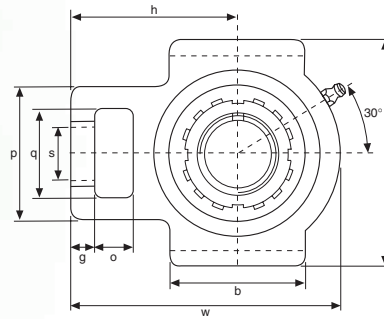
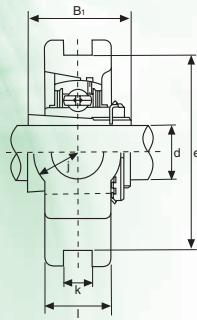

Tipo Type	Dimensioni mm/pollici Dimensions mm/inch																Coefficienti di carico (N) Load ratings (N)		Cuscinetto Bearing	Supporto Housing	Peso Weight (kg)
	d	o	g	p	q	s	b	k	e	a	w	j	l	h	t	B	Dinamico C Dynamic C	Statico C <sub>0</sub> Static C <sub>0</sub>			
UKT205+H2305 UKT205+HE2305	20 3/4	16 5/8	10 29/64	51 1 1/4	32 1 1/4	19 3/4	51 2 1/4	12 15/32	76 2 59/64	89 3 1/2	97 3 13/16	32 1 1/4	24 1 5/16	62 2 7/16	48 1 7/8	35 1,378	13 500	7 500	UK205+H2305 UK205+HE2305	T205	0,86
UKT206+H2306 UKT206+HS2306 UKT206+HE2306	25 7/8 1	16 5/8	10 29/64	56 27/32	37 1 15/32	22 55/64	57 2 1/4	12 15/32	89 3 1/2	102 4 1/4	113 4 29/64	37 1 29/64	28 1 3/32	70 2 3/4	53 2 3/32	38 1,496	18 600	10 800	UK206+H2306 UK206+HS2306 UK206+HE2306	T206	1,26
UKT207+H2307 UKT207+HS2307	30 1 1/8	16 5/8	13 33/64	64 2 33/64	37 1 15/32	22 55/64	64 2 33/64	12 15/32	89 3 1/2	102 4 1/4	129 5 9/64	37 1 29/64	30 1 1/16	78 3 3/4	59,5 2 11/32	43 1,693	24 500	14 600	UK207+H2307 UK207+HS2307	T207	2,50
UKT208+H2308 UKT208+HE2308 UKT208+HS2308	35 1 1/4 1 3/8	19 3/4	16 5/8	83 3 17/64	49 1 15/16	29 1 9/16	83 3 17/64	16 5/8	102 4 1/4	114 4 31/64	144 5 43/64	49 1 15/16	35 1 3/8	89 3 1/2	69 2 23/32	46 1,811	27 700	16 900	UK208+H2308 UK208+HE2308 UK208+HS2308	T208	2,50
UKT209+H2309 UKT209+HA2309 UKT209+HE2309 UKT209+HS2309	40 1 7/16 1 1/2 1 5/8	19 3/4	16 5/8	83 3 17/64	49 1 15/16	29 1 9/16	83 3 17/64	16 5/8	102 4 1/4	117 4 39/64	144 5 43/64	49 1 15/16	35 1 3/8	87 3 27/64	69 2 23/32	50 1,969	31 000	19 400	UK209+H2309 UK209+HA2309 UK209+HE2309 UK209+HS2309	T209	2,51
UKT210+H2310 UKT210+HS2310 UKT210+HA2310 UKT210+HE2310	45 1 5/8 1 11/16 1 3/4	19 3/4	16 5/8	83 3 17/64	49 1 15/16	29 1 9/16	86 3 25/64	16 5/8	102 4 1/4	117 4 39/64	149 5 55/64	49 1 15/16	35 1 3/8	90 3 35/64	74,5 2 15/16	55 2,165	33 300	22 000	UK210+H2310 UK210+HS2310 UK210+HA2310 UK210+HE2310	T210	2,60
UKT211+H2311 UKT211+HS2311 UKT211+HA2311 UKT211+HE2311	50 1 7/8 1 15/16 2	25 63/64	19 3/4	102 4 1/4	64 2 1/32	35 1 3/8	95 3 3/4	22 55/64	130 5 1/8	146 5 3/4	171 6 47/64	64 2 33/64	41 1 5/8	106 4 11/64	76 3	59 2,323	41 400	27 800	UK211+H2311 UK211+HS2311 UK211+HA2311 UK211+HE2311	T211	4,26
UKT212+H2312 UKT212+HS2312	55 2 1/8	32 1 7/64	19 3/4	102 4 1/4	64 2 1/32	35 1 3/8	102 4 1/4	22 55/64	130 5 1/8	146 5 3/4	194 7 41/64	64 2 33/64	46 1 13/16	119 4 11/16	89 3 1/2	62 2,441	49 900	34 200	UK212+H2312 UK212+HS2312	T212	5,02
UKT213+H2313 UKT213+HA2313 UKT213+HE2313 UKT213+HS2313	60 2 3/16 2 1/4 2 3/8	32 1 17/64	21 53/64	111 4 3/8	70 2 3/4	41 1 39/64	121 4 49/64	26 1 1/32	151 5 15/16	167 6 37/64	224 8 13/16	70 2 3/4	51 2	137 5 25/64	89 3 1/2	65 2,559	54 700	38 000	UK213+H2313 UK213+HA2313 UK213+HE2313 UK213+HS2313	T213	6,56
UKT215+H2315 UKT215+HA2315 UKT215+HE2315	65 2 7/16 2 1/2	32 1 17/64	21 53/64	111 4 3/8	70 2 3/4	41 1 39/64	121 4 49/64	26 1 1/32	151 5 15/16	167 6 37/64	232 9 9/64	70 2 3/4	48 1 57/64	140 5 33/64	-	73 2,874	63 000	47 000	UK215+H2315 UK215+HA2315 UK215+HE2315	T215	7,52
UKT216+H2316 UKT216+HA2316 UKT216+HE2316	70 2 11/16 2 3/4	32 1 17/64	21 53/64	111 4 3/8	70 2 3/4	41 1 39/64	121 4 49/64	26 1 1/32	165 6 1/2	184 7 1/4	235 9 1/4	70 2 3/4	51 2	140 5 33/64	-	78 3,071	68 900	51 000	UK216+H2316 UK216+HA2316 UK216+HE2316	T216	8,56
UKT217+H2317 UKT217+HA2317 UKT217+HE2317	75 2 15/16 3	38 1 1/2	29 1 9/64	124 4 7/8	73 2 7/8	48 1 57/64	157 6 1/16	30 1 9/16	173 6 13/16	198 7 51/64	260 10 15/64	73 2 7/8	54 2 1/8	162 6 3/8	-	82 3,228	80 000	61 000	UK217+H2317 UK217+HA2317 UK217+HE2317	T217	11,38

Bussole HA; HE; HS con filettatura in pollici  
Inch dimension adapter sleeves HA; HE; HS



**UCTX Serie media Medium Series**

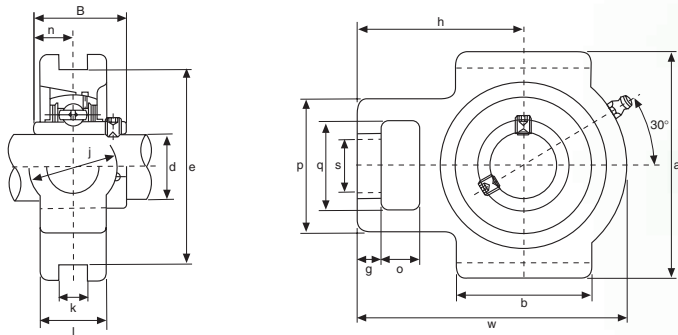

Tipo Type	Dimensioni mm/pollici Dimensions mm/inch															Coefficients di carico (N) Load ratings (N)		Cuscinetto Bearing	Supporto Housing	Peso Weight (kg)	
	d	o	g	p	q	s	b	k	e	a	w	l	j	h	B	n	Dinamico C Dynamic C				Statico C <sub>0</sub> Static C <sub>0</sub>
<b>UCTX05</b> <b>UCTX05-13</b> <b>UCTX05-14</b> <b>UCTX05-15</b> <b>UCTX05-16</b>	25 1 3/16 7/8 1 5/16 1	16 5/8	12 15/32	56 2 7/32	37 1 15/32	22 55/64	57 2 1/4	12 0,472	89 3 1/2	102 4 1/4	113 4 29/64	28 1 3/32	37 1 29/64	70 2 3/4	38,1 1,5000	15,9 0,626	18 600	10 800	<b>UCX05</b> <b>UCX05-13</b> <b>UCX05-14</b> <b>UCX05-15</b> <b>UCX05-16</b>	<b>TX05</b>	1,4
<b>UCTX06</b> <b>UCTX06-17</b> <b>UCTX06-18</b> <b>UCTX06-19</b> <b>UCTX06-20</b>	30 1 1/16 1 1/8 1 3/16 1 1/4	16 5/8	15 19/32	64 2 33/64	37 1 29/64	22 55/64	64 2 33/64	12 0,472	89 3 1/2	102 4 1/4	129 5 5/64	30 1 3/16	37 1 29/64	78 3 5/64	42,9 1,6890	17,5 0,689	24 500	14 600	<b>UCX06</b> <b>UCX06-17</b> <b>UCX06-18</b> <b>UCX06-19</b> <b>UCX06-20</b>	<b>TX06</b>	1,8
<b>UCTX07</b> <b>UCTX07-21</b> <b>UCTX07-22</b> <b>UCTX07-23</b>	35 1 5/16 1 3/8 1 7/16	19 3/4	17 2 1/32	83 3 17/64	49 1 15/16	29 1 9/64	83 3 17/64	16 0,630	102 4 1/4	114 4 31/64	144 5 43/64	36 1 13/32	49 1 15/16	88 3 15/32	49,2 1,9370	19 0,748	27 700	17 000	<b>UCX07</b> <b>UCX07-21</b> <b>UCX07-22</b> <b>UCX07-23</b>	<b>TX07</b>	2,6
<b>UCTX08</b> <b>UCTX08-24</b> <b>UCTX08-25</b>	40 1 1/2 1 9/16	19 3/4	17 2 1/32	83 3 17/64	49 1 15/16	29 1 9/64	83 3 17/64	16 0,630	102 4 1/4	117 4 39/64	144 5 43/64	36 1 13/32	49 1 15/16	87 3 27/64	49,2 1,9370	19 0,748	30 900	19 400	<b>UCX08</b> <b>UCX08-24</b> <b>UCX08-25</b>	<b>TX08</b>	2,6
<b>UCTX09</b> <b>UCTX09-26</b> <b>UCTX09-27</b> <b>UCTX09-28</b> <b>UCTX09-29</b>	45 1 5/8 1 11/16 1 3/4 1 13/16	19 3/4	18 23/32	83 3 17/64	49 1 15/16	29 1 9/64	86 3 25/64	16 0,630	102 4 1/4	117 4 39/64	151 5 15/16	38 1 1/2	49 1 15/16	92 3 5/8	51,6 2,0315	19 0,748	33 000	22 100	<b>UCX09</b> <b>UCX09-26</b> <b>UCX09-27</b> <b>UCX09-28</b> <b>UCX09-29</b>	<b>TX09</b>	2,8
<b>UCTX10</b> <b>UCTX10-30</b> <b>UCTX10-31</b> <b>UCTX10-32</b>	50 1 7/8 1 15/16 2	25 63/64	21 13/16	102 4 1/4	64 2 1/32	35 1 3/8	95 3 3/4	22 0,866	130 5 1/8	146 5 3/4	171 6 47/64	42 1 21/32	64 2 33/64	106 4 11/64	55,6 2,1890	22,2 0,874	41 400	27 800	<b>UCX10</b> <b>UCX10-30</b> <b>UCX10-31</b> <b>UCX10-32</b>	<b>TX10</b>	4,3
<b>UCTX11</b> <b>UCTX11-33</b> <b>UCTX11-34</b> <b>UCTX11-35</b> <b>UCTX11-36</b> <b>UCTX11-37</b>	55 2 1/16 2 1/8 2 3/16 2 1/4 2 5/16	32 1 1/4	21 13/16	102 4 1/4	64 2 1/32	35 1 3/8	102 4 1/4	22 0,866	130 5 1/8	146 5 3/4	194 7 41/64	44 1 23/32	64 2 33/64	119 4 11/16	65,1 2,5630	25,4 1,000	49 900	34 200	<b>UCX11</b> <b>UCX11-33</b> <b>UCX11-34</b> <b>UCX11-35</b> <b>UCX11-36</b> <b>UCX11-37</b>	<b>TX11</b>	5,2
<b>UCTX12</b> <b>UCTX12-38</b> <b>UCTX12-39</b>	60 2 3/8 2 7/16	32 1 1/4	23 29/32	111 4 3/8	70 2 3/4	41 1 39/64	121 4 49/64	26 1,024	151 5 15/16	167 6 37/64	224 8 13/16	48 1 57/64	70 2 3/4	137 5 25/64	65,1 2,5630	25,4 1,000	54 700	38 000	<b>UCX12</b> <b>UCX12-38</b> <b>UCX12-39</b>	<b>TX12</b>	7,6
<b>UCTX13</b> <b>UCTX13-40</b> <b>UCTX13-41</b>	65 2 1/2 2 9/16	32 1 1/4	23 29/32	111 4 3/8	70 2 3/4	41 1 39/64	121 4 49/64	26 1,024	151 5 15/16	167 6 37/64	224 8 13/16	48 1 57/64	70 2 3/4	137 5 25/64	74,6 2,9370	30,2 1,189	58 900	41 800	<b>UCX13</b> <b>UCX13-40</b> <b>UCX13-41</b>	<b>TX13</b>	7,6
<b>UCTX14</b> <b>UCTX14-42</b> <b>UCTX14-43</b> <b>UCTX14-44</b>	70 2 5/8 2 11/16 2 3/4	32 1 1/4	23 29/32	111 4 3/8	70 2 3/4	41 1 39/64	121 4 49/64	26 1,024	151 5 15/16	167 6 37/64	232 9 9/64	48 1 57/64	70 2 3/4	140 5 33/64	77,8 3,0630	33,3 1,311	63 000	47 100	<b>UCX14</b> <b>UCX14-42</b> <b>UCX14-43</b> <b>UCX14-44</b>	<b>TX14</b>	7,7
<b>UCTX15</b> <b>UCTX15-45</b> <b>UCTX15-46</b> <b>UCTX15-47</b> <b>UCTX15-48</b>	75 2 13/16 2 7/8 2 15/16 3	32 1 1/4	23 29/32	111 4 3/8	70 2 3/4	41 1 39/64	121 4 49/64	28 1,102	165 6 1/2	184 7 1/4	235 9 1/4	48 1 57/64	70 2 3/4	140 5 33/64	82,6 3,2520	33,3 1,311	68 900	50 500	<b>UCX15</b> <b>UCX15-45</b> <b>UCX15-46</b> <b>UCX15-47</b> <b>UCX15-48</b>	<b>TX15</b>	7,55
<b>UCTX16</b> <b>UCTX16-49</b> <b>UCTX16-50</b> <b>UCTX16-51</b> <b>UCTX16-52</b>	80 3 1/16 3 1/8 3 3/16 3 1/4	38 1 1/2	30 1 3/16	124 4 7/8	73 2 7/8	48 1 57/64	157 6 3/16	28 1,102	173 6 13/16	198 7 51/64	260 10 15/64	54 2 1/8	73 2 7/8	162 6 3/8	85,7 3,3740	34,1 1,343	79 400	61 000	<b>UCX16</b> <b>UCX16-49</b> <b>UCX16-50</b> <b>UCX16-51</b> <b>UCX16-52</b>	<b>TX16</b>	11
<b>UCTX17</b> <b>UCTX17-53</b> <b>UCTX17-54</b>	85 3 5/16 3 7/16	38 1 1/2	30 1 3/16	124 4 7/8	73 2 7/8	48 1 57/64	157 6 3/16	28 1,102	173 6 13/16	198 7 51/64	260 10 15/64	54 2 1/8	73 2 7/8	162 6 3/8	96 3,7795	39,7 1,5630	91 500	68 000	<b>UCX17</b> <b>UCX17-53</b> <b>UCX17-54</b>	<b>TX017</b>	12

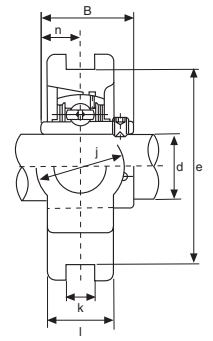
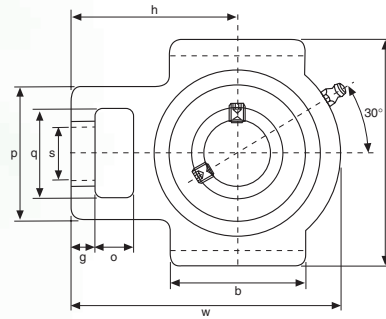

Tipo Type	Dimensioni mm/pollici Dimensions mm/inch																Coefficients di carico (N) Load ratings (N)		Cuscinetto Bearing	Supporto Housing	Peso Weight (kg)
	d	o	g	p	q	s	b	k	e	a	w	j	l	h	B	n	Dinamico C Dynamic C	Statico C <sub>0</sub> Static C <sub>0</sub>			
UCT305 UCT305-13 UCT305-14 UCT305-15 UCT305-16	25 1 1/16	16	14	62	36	26	65	12	80	89	122	36	26	76	38	15	20 200	11 930	UC305 UC305-13 UC305-14 UC305-15 UC305-16	T305	1,4
UCT306 UCT306-17 UCT306-18 UCT306-19	30 1 1/16	18	16	70	41	28	74	16	90	100	137	41	28	85	43	17	25 400	14 300	UC306 UC306-17 UC306-18 UC306-19	T306	1,8
UCT307 UCT307-20 UCT307-21 UCT307-22 UCT307-23	35 1 1/4	20	17	75	45	30	80	16	100	111	150	45	32	94	48	19	31 900	18 200	UC307 UC307-20 UC307-21 UC307-22 UC307-23	T307	2,4
UCT308 UCT308-24 UCT308-25	40 1 1/2	22	19	83	50	32	89	18	112	124	162	50	34	100	52	19	38 500	23 000	UC308 UC308-24 UC308-25	T308	3,0
UCT309 UCT309-26 UCT309-27 UCT309-28	45 1 5/8	24	20	90	55	34	97	18	125	138	178	55	38	110	57	22	50 500	30 500	UC309 UC309-26 UC309-27 UC309-28	T309	4,0
UCT310 UCT310-29 UCT310-30 UCT310-31	50 1 7/8	27	22	98	61	37	106	20	140	151	192	61	40	118	61	22	59 000	36 600	UC310 UC310-29 UC310-30 UC310-31	T310	5,0
UCT311 UCT311-32 UCT311-33 UCT311-34 UCT311-35	55 2	29	23	105	66	39	115	22	150	163	207	66	44	127	66	25	68 000	43 000	UC311 UC311-32 UC311-33 UC311-34 UC311-35	T311	6,4
UCT312 UCT312-36 UCT312-37 UCT312-38 UCT312-39	60 2 1/4	31	25	113	71	41	123	22	160	178	220	71	46	135	71	26	78 000	49 500	UC312 UC312-36 UC312-37 UC312-38 UC312-39	T312	7,6
UCT313 UCT313-40 UCT313-41	65 2 1/2	32	27	116	70	43	134	26	170	190	238	80	50	146	75	30	88 000	57 000	UC313 UC313-40 UC313-41	T313	9,7
UCT314 UCT314-42 UCT314-43 UCT314-44	70 2 5/8	36	27	130	85	46	140	26	180	202	252	90	52	155	78	33	99 000	64 600	UC314 UC314-42 UC314-43 UC314-44	T314	11
UCT315 UCT315-45 UCT315-46 UCT315-47 UCT315-48	75 2 7/8	36	27	132	85	46	150	26	192	216	262	90	55	160	82	32	108 000	73 500	UC315 UC315-45 UC315-46 UC315-47 UC315-48	T315	14
UCT316 UCT316-49 UCT316-50 UCT316-51	80 3 1/8	42	30	150	98	53	160	30	204	230	282	102	60	174	86	34	117 000	83 000	UC316 UC316-49 UC316-50 UC316-51	T316	16
UCT317 UCT317-52 UCT317-53 UCT317-55	85 3 1/4	42	32	152	98	53	170	32	214	240	298	102	64	183	96	40	127 000	93 000	UC317 UC317-52 UC317-53 UC317-55	T317	20
UCT318 UCT318-55 UCT318-56	90 3 1/2	46	32	160	106	57	175	32	228	255	312	110	66	192	96	40	136 000	102 000	UC318 UC318-55 UC318-56	T318	22
UCT319 UCT319-58 UCT319-59 UCT319-60	95 3 5/8	46	33	165	106	57	180	35	240	270	322	110	72	197	103	41	145 000	113 000	UC319 UC319-58 UC319-59 UC319-60	T319	24
UCT320 UCT320-61 UCT320-62 UCT320-63 UCT320-64	100 3 7/8	48	34	175	115	59	200	35	260	290	345	120	75	210	108	42	165 000	134 000	UC320 UC320-61 UC320-62 UC320-63 UC320-64	T320	32



## PIASTRA CON TENDITORE PER UCT STRETCH SKID FOR UCT

**KDF®**

### UCT2 Serie normale Normal Series

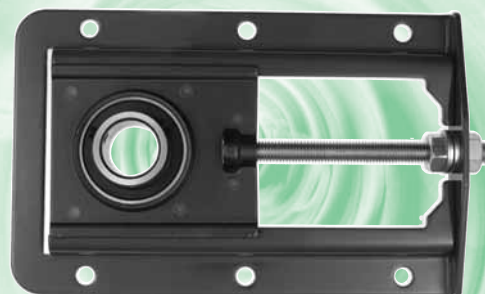
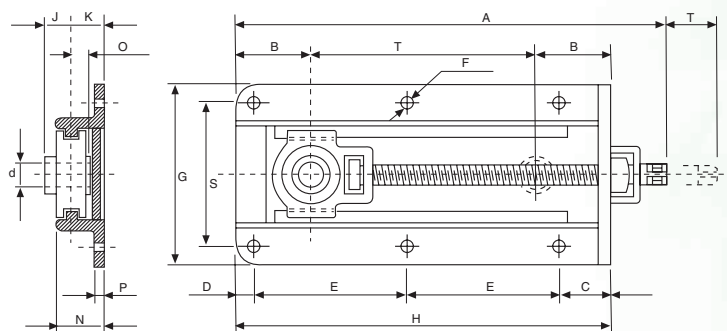

Tipo Type	Dimensioni mm Dimensions mm																Peso Weight (kg)
	d	A	B	C	D	E	F	G	H	J	K	N	O	P	S	T	
UCT204	20	380	80	60	20	120	11	194	320	18,3	28	45	12,7	5	154	160	4,4
UCT205	25	380	80	60	20	120	11	194	320	19,7	28	45	14,3	5	154	160	4,4
UCT206	30	480	95	64	20	158	11	206	400	22,2	32	45	15,9	5	166	210	6,2
UCT207	35	480	95	64	20	158	11	206	400	25,4	32	45	17,5	5	166	210	6,5
UCT208	40	600	105	58	22	220	13	234	520	30,2	32	50	19	5	190	310	10,9
UCT209	45	600	105	58	22	220	13	234	520	30,2	32	50	19	5	190	310	10,8
UCT210	50	600	105	58	22	220	13	234	520	32,6	32	50	19	5	190	310	11
UCT211	55	680	125	55	25	250	15	284	580	33,4	45	70	22,2	6	240	330	20,4
UCT212	60	680	125	55	25	250	15	284	580	39,7	45	70	25,4	6	240	330	21,3
UCT213	65	790	155	66	22	306	18	303	700	39,7	51	75	25,4	6	258	390	28,3
UCT214	70	790	155	66	22	306	18	303	700	44,4	51	75	30,2	6	258	390	28,1
UCT215	75	790	155	66	22	306	18	303	700	44,5	51	75	33,3	6	258	390	28,7
UCT216	80	890	165	75	25	230*	18	336	790	49,3	62	90	33,3	10	286	460	38,2
UCT217	85	920	180	75	25	240*	18	361	820	51,6	62	100	34,1	10	311	460	44

\* Piastre con quattro fori di fissaggio  
Stretch skid with four fixing hole



## PIASTRA CON TENDITORE PER UCT STRETCH SKID FOR UCT

### UCTX2 Serie normale Normal Series

Tipo Type	Dimensioni mm Dimensions mm																Peso Weight (kg)
	d	A	B	C	D	E	F	G	H	J	K	N	O	P	S	T	
UCTX-05	25	480	95	64	20	158	11	206	400	22,2	32	45	15,9	5	166	210	6,8
UCTX-06	30	480	95	64	20	158	11	206	400	25,4	32	45	17,5	5	166	210	7,0
UCTX-07	35	600	105	58	22	220	13	234	520	30,2	32	50	19,0	5	190	310	11,1
UCTX-08	40	600	105	58	22	220	13	234	520	30,2	32	50	19,0	5	190	310	11,1
UCTX-09	45	600	105	58	22	220	13	234	520	32,6	32	50	19,0	5	190	310	11,3
UCTX-10	50	680	125	55	25	250	15	284	580	33,4	45	70	22,2	6	240	330	20,1
UCTX-11	55	680	125	55	25	250	15	284	580	39,7	45	70	25,4	6	240	330	20,9
UCTX-12	60	790	155	66	22	306	18	303	700	39,7	51	75	25,4	6	258	390	28,1
UCTX-13	65	790	155	66	22	306	18	303	700	44,4	51	75	30,2	6	258	390	28,3
UCTX-14	70	790	155	66	22	306	18	303	700	44,5	51	75	33,3	6	258	390	28,6
UCTX-15	75	890	165	75	25	230*	18	336	790	49,3	62	90	33,3	10	286	460	38,1
UCTX-16	80	920	180	75	25	240*	18	365	820	51,6	62	100	34,1	10	315	460	49,5
UCTX-17	85	920	180	75	25	240*	18	365	820	56,3	62	100	39,7	10	315	460	49,4

\* Piastre con quattro fori di fissaggio  
Stretch skid with four fixing hole

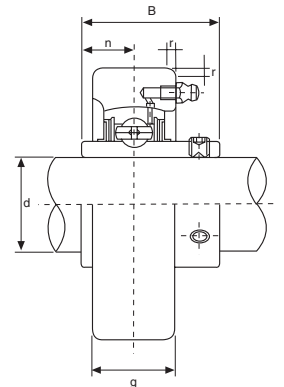
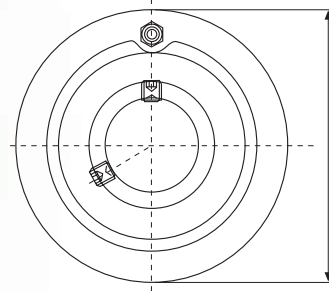

Tipo Type	Dimensioni mm/pollici Dimensions mm/inch						Coefficienti di carico (N) Load ratings (N)		Cuscinetto Bearing	Supporto Housing	Peso Weight (kg)
	d	a	g	r	B	n	Dinamico C Dynamic C	Statico C <sub>0</sub> Static C <sub>0</sub>			
UCC201 UCC201-8	12 3/4	72 2,8346	20 25/32	2 0,079	31 1,2205	12,7 0,500	12 200	6 350	UC201 UC201-8	C204	0,52 0,51
UCC202 UCC202-9 UCC202-10	15 9/16 5/8	72 2,8346	20 25/32	2 0,079	31 1,2205	12,7 0,500	12 200	6 350	UC202 UC202-9 UC202-10	C204	0,51 0,51 0,51
UCC203 UCC203-11	17 1 1/16	72 2,8346	20 25/32	2 0,079	31 1,2205	12,7 0,500	12 200	6 350	UC203 UC203-11	C204	0,50 0,49
UCC204 UCC204-12	20 3/4	72 2,8346	20 25/32	2 0,079	31 1,2205	12,7 0,500	12 200	6 350	UC204 UC204-12	C204	0,48 0,48
UCC205 UCC205-13 UCC205-14 UCC205-15 UCC205-16	25 1 3/16 7/8 15/16 1	80 3,1496	22 55/64	2 0,079	34,1 1,3425	14,3 0,563	13 300	7 500	UC205 UC205-13 UC205-14 UC205-15 UC205-16	C205	0,63 0,67 0,66 0,64 0,63
UCC206 UCC206-17 UCC206-18 UCC206-19 UCC206-20	30 1 1/16 1 1/8 1 3/16 1 1/4	85 3,3465	27 1 1/16	2 0,079	38,1 1,5000	15,9 0,626	18 600	10 800	UC206 UC206-17 UC206-18 UC206-19 UC206-20	C206	0,80 0,83 0,82 0,80 0,79
UCC207 UCC207-20 UCC207-21 UCC207-22 UCC207-23	35 1 1/4 1 5/16 1 3/8 1 7/16	90 3,5433	28 1 7/64	2 0,079	4,9 1,6890	17,5 0,689	24 500	14 600	UC207 UC207-20 UC207-21 UC207-22 UC207-23	C207	0,93 0,99 0,96 0,93 0,90
UCC208 UCC208-24 UCC208-25	40 1 1/2 1 9/16	100 3,9370	30 1 3/16	2,5 0,098	49,2 1,9370	19 0,748	27 700	17 000	UC208 UC208-24 UC208-25	C208	1,22 1,26 1,23
UCC209 UCC209-26 UCC209-27 UCC209-28	45 1 5/8 1 11/16 1 3/4	110 4,3307	31 1 7/32	2,5 0,098	49,2 1,9370	19 0,748	31 000	19 500	UC209 UC209-26 UC209-27 UC209-28	C209	1,49 1,59 1,55 1,51
UCC210 UCC210-29 UCC210-30 UCC210-31 UCC210-32	50 1 13/16 1 7/8 1 15/16 2	120 4,7244	33 1 1/64	2,5 0,098	51,6 2,0315	19 0,748	33 500	22 500	UC210 UC210-29 UC210-30 UC210-31 UC210-32	C210	1,90 2,02 1,97 1,92 1,88
UCC211 UCC211-32 UCC211-33 UCC211-34 UCC211-35	55 2 2 1/16 2 1/8 2 3/16	125 4,9213	35 1 3/8	2,5 0,098	55,6 2,1890	22,2 0,874	41 500	28 000	UC211 UC211-32 UC211-33 UC211-34 UC211-35	C211	2,18 2,33 2,27 2,22 2,16
UCC212 UCC212-36 UCC212-37 UCC212-38 UCC212-39	60 2 1/4 2 5/16 2 3/8 2 7/16	130 5,1181	38 1 1/2	2,5 0,098	65,1 2,5630	25,4 1,000	50 000	34 500	UC212 UC212-36 UC212-37 UC212-38 UC212-39	C212	2,52 2,65 2,57 2,50 2,43
UCC213 UCC213-40 UCC213-41	65 2 1/2 2 9/16	140 5,5118	40 1 37/64	3 0,118	65,1 2,5630	25,4 1,000	54 700	38 000	UC213 UC213-40 UC213-41	C213	2,98 3,07 2,98

Disponibile in acciaio inox Supporto: AISI 304 - Cuscinetto: AISI 440C  
Disponibile su richiesta con cuscinetto SA (SACC)

Available stainless steel Housing: AISI 304 - Bearing: AISI 440C  
Available under request with SA bearing (SACC)





# SUPPORTI A CARTUCCIA CYLINDRICAL CARTRIDGE UNITS

# KDF®

## HCC2 Serie normale Normal Series

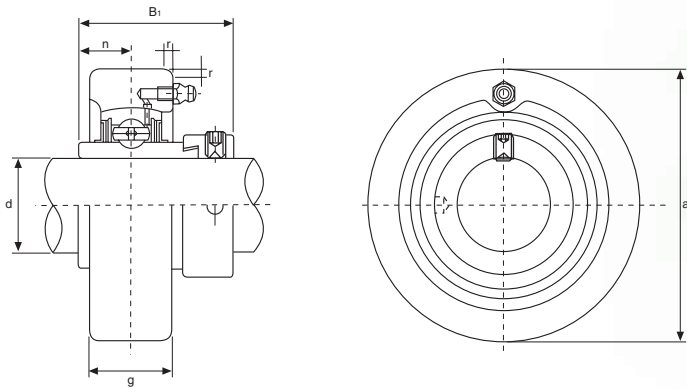

Tipo Type	Dimensioni mm/pollici Dimensions mm/inch						Coefficienti di carico (N) Load ratings (N)		Cuscinetto Bearing	Supporto Housing	Peso Weight (kg)
	d	a	g	r	B <sub>1</sub>	n	Dinamico C Dynamic C	Statico C <sub>0</sub> Static C <sub>0</sub>			
HCC204 HCC204-12	20 ¾	72 2,8346	20 25/32	2 0,079	43,7 1,720	17,1 0,673	12 200	6 350	HC204 HC204-12	C204	0,55 0,55
HCC205 HCC205-13 HCC205-14 HCC205-15 HCC205-16	25 1 1/16 7/8 1 1/16 1	80 3,1496	22 55/64	2 0,079	44,4 1,748	17,5 0,689	13 300	7 500	HC205 HC205-13 HC205-14 HC205-15 HC205-16	C205	0,70 0,75 0,74 0,72 0,70
HCC206 HCC206-17 HCC206-18 HCC206-19 HCC206-20	30 1 1/16 1 1/8 1 1/16 1 1/4	85 3,3465	27 1 1/16	2 0,079	48,4 1,906	18,3 0,720	18 600	10 800	HC206 HC206-17 HC206-18 HC206-19 HC206-20	C206	0,93 0,98 0,95 0,93 0,90
HCC207 HCC207-20 HCC207-21 HCC207-22 HCC207-23	35 1 1/4 1 5/16 1 3/8 1 7/16	90 3,5433	28 1 7/64	2 0,079	51,1 2,012	18,8 0,740	24 500	14 600	HC207 HC207-20 HC207-21 HC207-22 HC207-23	C207	1,05 1,12 1,08 1,05 1,02
HCC208 HCC208-24 HCC208-25	40 1 1/2 1 9/16	100 3,9370	30 1 3/16	2,5 0,098	56,3 2,217	21,4 0,843	27 700	17 000	HC208 HC208-24 HC208-25	C208	1,37 1,42 1,38
HCC209 HCC209-26 HCC209-27 HCC209-28	45 1 5/8 1 11/16 1 3/4	110 4,3307	31 1 7/32	2,5 0,098	56,3 2,217	21,4 0,843	31 000	19 500	HC209 HC209-26 HC209-27 HC209-28	C209	1,66 1,77 1,72 1,68
HCC210 HCC210-29 HCC210-30 HCC210-31 HCC210-32	50 1 13/16 1 7/8 1 15/16 2	120 4,7244	33 1 1/64	2,5 0,098	62,7 2,469	24,6 0,969	33 500	22 500	HC210 HC210-29 HC210-30 HC210-31 HC210-32	C210	2,09 2,24 2,18 2,12 2,06
HCC211 HCC211-32 HCC211-33 HCC211-34 HCC211-35	55 2 2 1/16 2 1/8 2 3/16	125 4,9213	35 1 3/8	2,5 0,098	71,4 2,811	27,8 1,094	41 500	28 000	HC211 HC211-32 HC211-33 HC211-34 HC211-35	C211	2,39 2,59 2,51 2,44 2,36
HCC212 HCC212-36 HCC212-37 HCC212-38 HCC212-39	60 2 1/4 2 5/16 2 3/8 2 7/16	130 5,1181	38 1 1/2	2,5 0,098	77,8 3,063	31 1,220	50 000	34 500	HC212 HC212-36 HC212-37 HC212-38 HC212-39	C212	2,86 3,02 2,93 2,88 2,75

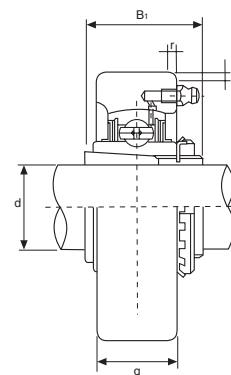
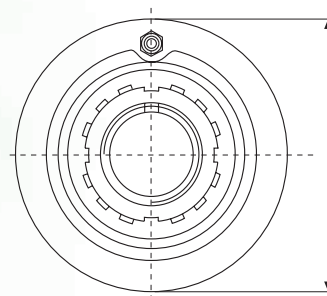

Tipo Type	Dimensioni mm/pollici Dimensions mm/inch					Coefficienti di carico (N) Load ratings (N)		Cuscinetto Bearing	Supporto Housing	Peso Weight (kg)
	d	a	g	r	B <sub>1</sub>	Dinamico C Dynamic C	Statico C <sub>0</sub> Static C <sub>0</sub>			
UKC205+H2305 UKC205+HE2305	20 ¾	80 3,1496	22 59/64	2 0,079	35 1,378	13 500	7 500	UK205+H2305 UK205+HE2305	C205	0,68
UKC206+H2306 UKC206+HS2306 UKC206+HE2306	25 7/8 1	85 3,3465	27 1 1/16	2 0,079	38 1,496	18 600	10 800	UK206+H2306 UK206+HS2306 UK206+HE2306	C206	0,84
UKC207+H2307 UKC207+HS2307	30 1 1/8	90 3,5433	28 1 7/64	2 0,079	43 1,693	24 500	14 600	UK207+H2307 UK207+HS2307	C207	1,02
UKC208+H2308 UKC208+HE2308 UKC208+HS2308	35 1 1/4 1 1/8	100 3,9370	30 1 3/16	2,5 0,098	46 1,811	27 700	16 900	UK208+H2308 UK208+HE2308 UK208+HS2308	C208	1,32
UKC209+H2309 UKC209+HA2309 UKC209+HE2309 UKC209+HS2309	40 1 7/16 1 1/2 1 5/8	110 4,3307	31 1 7/32	2,5 0,098	50 1,969	31 000	19 400	UK209+H2309 UK209+HA2309 UK209+HE2309 UK209+HS2309	C209	1,64
UKC210+H2310 UKC210+HS2310 UKC210+HA2310 UKC210+HE2310	45 1 7/8 1 11/16 1 3/4	120 4,7244	33 1 19/64	2,5 0,098	55 2,165	33 300	22 000	UK210+H2310 UK210+HS2310 UK210+HA2310 UK210+HE2310	C210	2,07
UKC211+H2311 UKC211+HS2311 UKC211+HA2311 UKC211+HE2311	50 1 7/8 1 15/16 2	125 4,9213	35 1 3/8	2,5 0,098	59 2,323	41 400	27 800	UK211+H2311 UK211+HS2311 UK211+HA2311 UK211+HE2311	C211	2,33
UKC212+H2312 UKC212+HS2312	55 2 1/8	130 5,1181	38 1 1/2	2,5 0,098	62 2,441	49 900	34 200	UK212+H2312 UK212+HS2312	C212	2,57
UKC213+H2313 UKC213+HA2313 UKC213+HE2313 UKC213+HS2313	60 2 3/16 2 1/4 2 3/8	140 5,5118	40 1 37/64	3 0,118	65 2,559	54 700	38 000	UK213+H2313 UK213+HA2313 UK213+HE2313 UK213+HS2313	C213	2,89

Bussole HA; HE; HS con filettatura in pollici  
Inch dimension adapter sleeves HA; HE; HS



## SUPPORTI A CARTUCCIA CYLINDRICAL CARTRIDGE UNITS

# KDF®

### UCCX Serie media Medium Series

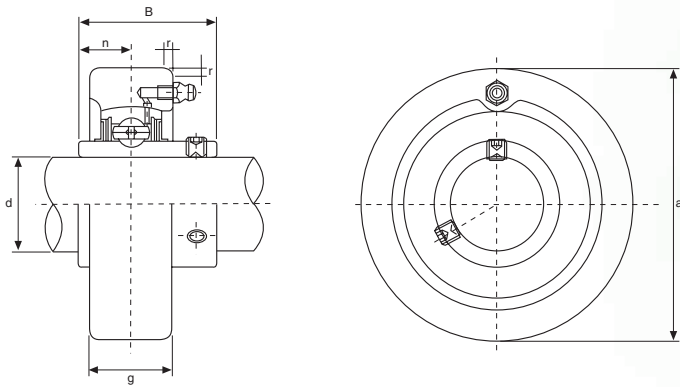

Tipo Type	Dimensioni mm/pollici Dimensions mm/inch						Coefficienti di carico (N) Load ratings (N)		Cuscinetto Bearing	Supporto Housing	Peso Weight (kg)
	d	a	g	r	B	n	Dinamico C Dynamic C	Statico C <sub>0</sub> Static C <sub>0</sub>			
UCCX05 UCCX05-13 UCCX05-14 UCCX05-15 UCCX05-16	25 1 <sup>3</sup> / <sub>16</sub> 7/ <sub>8</sub> 1 <sup>5</sup> / <sub>16</sub> 1	90 3,5433	27 1 <sup>1</sup> / <sub>16</sub>	2 0,079	38,1 1,5000	15,9 0,626	18 600	10 800	UCX05 UCX05-13 UCX05-14 UCX05-15 UCX05-16	CX05	1,1
UCCX06 UCCX06-17 UCCX06-18 UCCX06-19 UCCX06-20	30 1 <sup>1</sup> / <sub>16</sub> 1 <sup>1</sup> / <sub>8</sub> 1 <sup>3</sup> / <sub>16</sub> 1 <sup>1</sup> / <sub>4</sub>	100 3,9370	30 1 <sup>3</sup> / <sub>16</sub>	2,5 0,098	42,9 1,6890	17,5 0,689	24 500	14 600	UCX06 UCX06-17 UCX06-18 UCX06-19 UCX06-20	CX06	1,6
UCCX07 UCCX07-21 UCCX07-22 UCCX07-23	35 1 <sup>5</sup> / <sub>16</sub> 1 <sup>3</sup> / <sub>8</sub> 1 <sup>7</sup> / <sub>16</sub>	110 4,3307	34 1 <sup>11</sup> / <sub>32</sub>	2,5 0,098	49,2 1,9370	19 0,748	27 700	17 000	UCX07 UCX07-21 UCX07-22 UCX07-23	CX07	2,0
UCCX08 UCCX08-24 UCCX08-25	40 1 <sup>1</sup> / <sub>2</sub> 1 <sup>7</sup> / <sub>16</sub>	120 4,7244	38 1 <sup>1</sup> / <sub>2</sub>	2,5 0,098	49,2 1,9370	19 0,748	30 900	19 400	UCX08 UCX08-24 UCX08-25	CX08	2,5
UCCX09 UCCX09-26 UCCX09-27 UCCX09-28 UCCX09-29	45 1 <sup>5</sup> / <sub>8</sub> 1 <sup>11</sup> / <sub>16</sub> 1 <sup>3</sup> / <sub>4</sub> 1 <sup>13</sup> / <sub>16</sub>	120 4,7244	38 1 <sup>1</sup> / <sub>2</sub>	2,5 0,098	51,6 2,0315	19 0,748	33 000	22 100	UCX09 UCX09-26 UCX09-27 UCX09-28 UCX09-29	CX09	2,4
UCCX10 UCCX10-31 UCCX10-32 UCCX10-33	50 1 <sup>7</sup> / <sub>8</sub> 1 <sup>15</sup> / <sub>16</sub> 2	130 5,1181	40 1 <sup>37</sup> / <sub>64</sub>	2,5 0,098	55,6 2,1890	22,2 0,874	41 400	27 800	UCX10 UCX10-31 UCX10-32 UCX10-33	CX10	3,0
UCCX11 UCCX11-33 UCCX11-34 UCCX11-35 UCCX11-36 UCCX11-37	55 2 <sup>1</sup> / <sub>16</sub> 2 <sup>1</sup> / <sub>8</sub> 2 <sup>3</sup> / <sub>16</sub> 2 <sup>1</sup> / <sub>4</sub> 2 <sup>5</sup> / <sub>16</sub>	150 5,9055	42 1 <sup>21</sup> / <sub>32</sub>	3 0,118	65,1 2,5630	25,4 1,000	49 900	34 200	UCX11 UCX11-33 UCX11-34 UCX11-35 UCX11-36 UCX11-37	CX11	4,4
UCCX12 UCCX12-38 UCCX12-39	60 2 <sup>3</sup> / <sub>8</sub> 2 <sup>7</sup> / <sub>16</sub>	160 6,2992	44 1 <sup>47</sup> / <sub>64</sub>	3 0,118	65,1 2,5630	25,4 1,000	54 700	38 000	UCX12 UCX12-38 UCX12-39	CX12	5,0

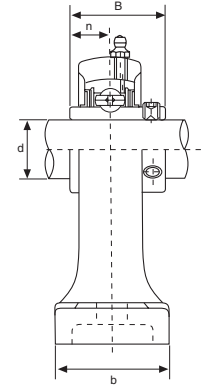
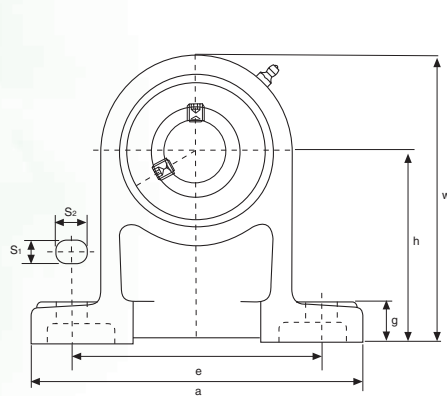

Tipo Type	Dimensioni mm/pollici Dimensions mm/inch											Bull. fiss. Bolt Size mm/inch	Coefficienti di carico (N) Load ratings (N)		Cuscinetto Bearing	Supporto Housing	Peso Weight (kg)
	d	h	a	e	b	S <sub>1</sub>	S <sub>2</sub>	g	w	B	n		Dinamico C Dynamic C	Statico C <sub>0</sub> Static C <sub>0</sub>			
UCPH201 UCPH201-8	12 3/4	70 2 3/4	127 5	95 3 3/4	40 1 5/8	13 1/2	19 3/4	15 1 1/2	101 3 5/8	31 1,2205	12,7 0,500	M10 3/8	12 200	6 350	UC201 UC201-8	PH204	0,81 0,80
UCPH202 UCPH202-9 UCPH202-10	15 9/16 5/8	70 2 3/4	127 5	95 3 3/4	40 1 5/8	13 1/2	19 3/4	15 1 1/2	101 3 5/8	31 1,2205	12,7 0,500	M10 3/8	12 200	6 350	UC202 UC202-9 UC202-10	PH204	0,80 0,80 0,80
UCPH203 UCPH203-11	17 1 1/16	70 2 3/4	127 5	95 3 3/4	40 1 5/8	13 1/2	19 3/4	15 1 1/2	101 3 5/8	31 1,2205	12,7 0,500	M10 3/8	12 200	6 350	UC203 UC203-11	PH204	0,79 0,78
UCPH204 UCPH204-12	20 3/4	70 2 3/4	127 5	95 3 3/4	40 1 5/8	13 1/2	19 3/4	15 1 1/2	101 3 5/8	31 1,2205	12,7 0,500	M10 3/8	12 200	6 350	UC204 UC204-12	PH204	0,77 0,77
UCPH205 UCPH205-13 UCPH205-14 UCPH205-15 UCPH205-16	25 1 3/16 7/8 1 1/16 1	80 3 1/2	140 5 1/2	105 4 1/8	50 1 31/32	13 1/2	19 3/4	16 5/8	114 4 1/4	34,1 1,3425	14,3 0,563	M10 3/8	13 300	7 500	UC205 UC205-13 UC205-14 UC205-15 UC205-16	PH205	1,01 1,05 1,04 1,02 1,01
UCPH206 UCPH206-17 UCPH206-18 UCPH206-19 UCPH206-20	30 1 1/16 1 1/8 1 1/16 1 1/4	90 3 5/8	161 6 11/32	121 4 3/4	50 1 31/32	17 4 3/4	21 5 1/8	17 4 3/4	130 5 1/8	38,1 1,5000	15,9 0,626	M14 1/2	18 600	10 800	UC206 UC206-17 UC206-18 UC206-19 UC206-20	PH206	1,47 1,50 1,49 1,47 1,46
UCPH207 UCPH207-20 UCPH207-21 UCPH207-22 UCPH207-23	35 1 1/4 1 5/16 1 3/8 1 7/16	95 3 7/8	166 6 11/32	127 5	60 2 23/64	17 4 3/4	21 5 1/8	18 4 5/8	140 5 33/64	42,9 1,6890	17,5 0,689	M14 1/2	24 500	14 600	UC207 UC207-20 UC207-21 UC207-22 UC207-23	PH207	1,91 1,97 1,94 1,91 1,88
UCPH208 UCPH208-24 UCPH208-25	40 1 1/2 1 9/16	100 3 15/16	178 7 1/4	137 5 13/32	70 2 3/4	17 4 3/4	21 5 1/8	19 3/4	150 5 29/32	49,2 1,9370	19 0,748	M14 1/2	27 700	17 000	UC208 UC208-24 UC208-25	PH208	2,52 2,56 2,53
UCPH209 UCPH209-26 UCPH209-27 UCPH209-28	45 1 5/8 1 11/16 1 3/4	105 4 1/8	189 7 7/16	146 5 3/4	70 2 3/4	17 4 3/4	21 5 1/8	20 2 5/8	158 6 1/8	49,2 1,9370	19 0,748	M14 1/2	31 000	19 500	UC209 UC209-26 UC209-27 UC209-28	PH209	2,72 2,82 2,78 2,74
UCPH210 UCPH210-29 UCPH210-30 UCPH210-31 UCPH210-32	50 1 13/16 1 7/8 1 15/16 2	110 4 21/64	205 8 1/8	159 6 1/4	70 2 3/4	20 2 5/8	23 2 9/8	21 5 1/8	165 6 1/2	51,6 2,0315	19 0,748	M16 5/8	33 500	22 500	UC210 UC210-29 UC210-30 UC210-31 UC210-32	PH210	3,10 3,22 3,17 3,12 3,08
UCPH211 UCPH211-32 UCPH211-33 UCPH211-34 UCPH211-35	55 2 2 1/16 2 1/8 2 3/16	120 4 23/32	219 8 5/8	171 6 47/64	75 2 61/64	20 2 5/8	23 2 9/8	22 5 5/8	181 7 1/8	55,6 2,1890	22,2 0,874	M16 5/8	41 500	28 000	UC211 UC211-32 UC211-33 UC211-34 UC211-35	PH211	- - - - -
UCPH212 UCPH212-36 UCPH212-37 UCPH212-38 UCPH212-39	60 2 1/4 2 5/16 2 3/8 2 7/16	130 5 1/8	241 9 1/2	184 7 1/4	85 3 11/32	20 2 5/8	23 2 9/8	25 6 3/4	197 7 3/4	65,1 2,5630	25,4 1,000	M16 5/8	50 000	34 500	UC212 UC212-36 UC212-37 UC212-38 UC212-39	PH212	- - - - -
UCPH213 UCPH213-40 UCPH213-41	65 2 1/2 2 9/16	140 5 33/64	265 10 7/16	203 8	95 3 3/4	25 6 3/4	28 1 3/8	27 1 1/16	212 8 11/32	65,1 2,5630	25,4 1,000	M20 3/4	54 700	38 000	UC213 UC213-40 UC213-41	PH213	- - -
UCPH214 UCPH214-42 UCPH214-43 UCPH214-44	70 2 5/8 2 11/16 2 3/4	150 5 29/32	266 10 15/32	210 8 17/64	105 5 5/8	25 6 3/4	28 1 3/8	28 1 7/8	225 8 55/64	74,6 2,9370	30,2 1,189	M20 3/4	59 000	42 000	UC214 UC214-42 UC214-43 UC214-44	PH214	- - - -
UCPH215 UCPH215-45 UCPH215-46 UCPH215-47 UCPH215-48	75 2 13/16 2 7/8 2 15/16 3	160 5 1/8	275 10 53/64	217 8 35/64	115 4 17/32	25 6 3/4	28 1 3/8	29 1 1/4	238 9 3/8	77,8 3,0630	33,3 1,311	M20 3/4	63 000	47 000	UC215 UC215-45 UC215-46 UC215-47 UC215-48	PH215	- - - - -
UCPH216 UCPH216-49 UCPH216-50 UCPH216-51	80 3 1/16 3 1/8 3 3/16	170 6 11/16	292 11 1/2	232 9 1/8	125 4 59/64	25 6 3/4	28 1 3/8	30 1 3/16	253 9 51/64	82,6 3,2520	33,3 1,311	M20 3/4	69 000	51 000	UC216 UC216-49 UC216-50 UC216-51	PH216	- - - -

Disponibile in acciaio inox Supporto: AISI 304 - Cuscinetto: AISI 440C  
Disponibile su richiesta con cuscinetto SA (SAPH)

Available stainless steel Housing: AISI 304 - Bearing: AISI 440C  
Available under request with SA bearing (SAPH)



**SUPPORTI RITTI CON PIEDISTALLO CON BUSSOLA MONTATA**  
**PEDESTAL PILLOW BLOCKS WITH ADAPTER SLEEVE MOUNTED**

**KDF®**

**UKPH2 Serie normale Normal Series**

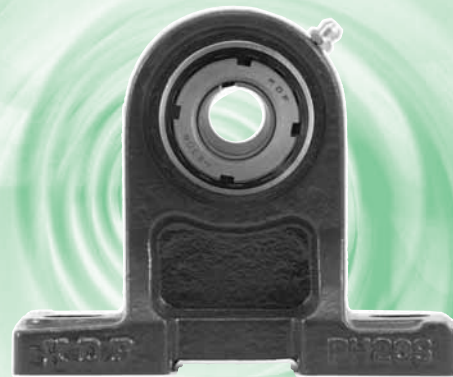
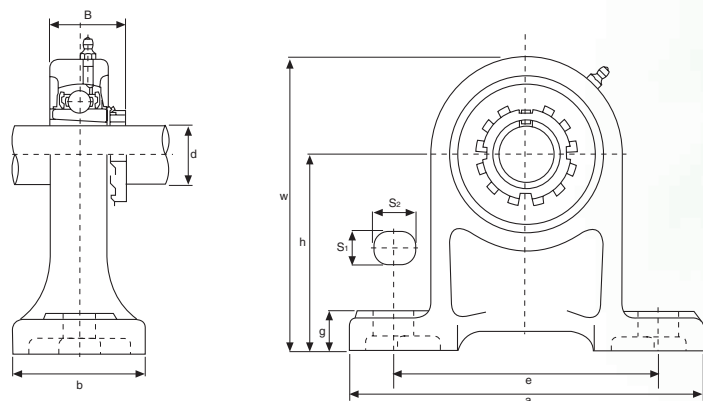

Tipo Type	Dimensioni mm/pollici Dimensions mm/inch										Bull. fiss. Bolt Size mm/inch	Coefficienti di carico (N) Load ratings (N)		Cuscinetto Bearing	Supporto Housing	Peso Weight (kg)
	d	h	a	e	b	S <sub>1</sub>	S <sub>2</sub>	g	w	B		Dinamico C Dynamic C	Statico C <sub>0</sub> Static C <sub>0</sub>			
UKPH205+H2305 UKPH205+HE2305	20 ¾	80 3 <sup>5</sup> / <sub>32</sub>	140 5½	105 4¼	50 1 <sup>3</sup> / <sub>32</sub>	13 ½	19 ¾	16 ⅝	114 4 <sup>3</sup> / <sub>64</sub>	34,1 1,3425	M10 ⅝	13 500	7 500	UK205+H2305 UK205+HE2305	PH205	1,24
UKPH206+H2306 UKPH206+HS2306 UKPH206+HE2306	25 7/8 1	90 3 <sup>35</sup> / <sub>64</sub>	161 6 <sup>1</sup> / <sub>32</sub>	121 4¾	50 1 <sup>3</sup> / <sub>32</sub>	17 4 <sup>3</sup> / <sub>64</sub>	21 5 <sup>3</sup> / <sub>64</sub>	17 4 <sup>3</sup> / <sub>64</sub>	130 5⅛	38,1 1,5000	M14 ½	18 600	10 800	UK206+H2306 UK206+HS2306 UK206+HE2306	PH206	1,64
UKPH207+H2307 UKPH207+HS2307	30 1½	95 3 <sup>47</sup> / <sub>64</sub>	166 6 <sup>17</sup> / <sub>32</sub>	127 5	60 2 <sup>23</sup> / <sub>64</sub>	17 4 <sup>3</sup> / <sub>64</sub>	21 5 <sup>3</sup> / <sub>64</sub>	18 4 <sup>5</sup> / <sub>64</sub>	140 5 <sup>33</sup> / <sub>64</sub>	42,9 1,6890	M14 ½	24 500	14 600	UK207+H2307 UK207+HS2307	PH207	2,03
UKPH208+H2308 UKPH208+HE2308 UKPH208+HS2308	35 1¼ 1¾	100 3 <sup>15</sup> / <sub>16</sub>	178 7¼	137 5 <sup>13</sup> / <sub>32</sub>	70 2¾	17 4 <sup>3</sup> / <sub>64</sub>	21 5 <sup>3</sup> / <sub>64</sub>	19 ¾	150 5 <sup>29</sup> / <sub>32</sub>	49,2 1,9370	M14 ½	27 700	16 900	UK208+H2308 UK208+HE2308 UK208+HS2308	PH208	2,72
UKPH209+H2309 UKPH209+HA2309 UKPH209+HE2309 UKPH209+HS2309	40 1 <sup>7</sup> / <sub>16</sub> 1½ 1⅝	105 4 <sup>9</sup> / <sub>64</sub>	189 7 <sup>7</sup> / <sub>16</sub>	146 5¾	70 2¾	17 4 <sup>3</sup> / <sub>64</sub>	21 5 <sup>3</sup> / <sub>64</sub>	20 2 <sup>5</sup> / <sub>32</sub>	158 6 <sup>7</sup> / <sub>32</sub>	49,2 1,9370	M14 ½	31 000	19 400	UK209+H2309 UK209+HA2309 UK209+HE2309 UK209+HS2309	PH209	3,09
UKPH210+H2310 UKPH210+HS2310 UKPH210+HA2310 UKPH210+HE2310	45 1⅝ 1 <sup>11</sup> / <sub>16</sub> 1¾	110 4 <sup>21</sup> / <sub>64</sub>	205 8 <sup>5</sup> / <sub>64</sub>	159 6¼	70 2¾	20 2 <sup>5</sup> / <sub>32</sub>	23 2 <sup>9</sup> / <sub>32</sub>	21 5 <sup>3</sup> / <sub>64</sub>	165 6½	51,6 2,0315	M16 ⅝	33 300	22 000	UK210+H2310 UK210+HS2310 UK210+HA2310 UK210+HE2310	PH210	3,59

Bussole HA; HE; HS con filettatura in pollici  
 Inch dimension adapter sleeves HA; HE; HS

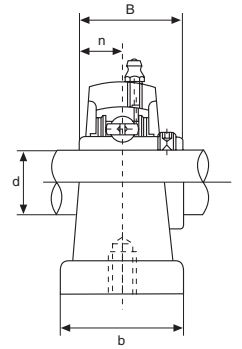
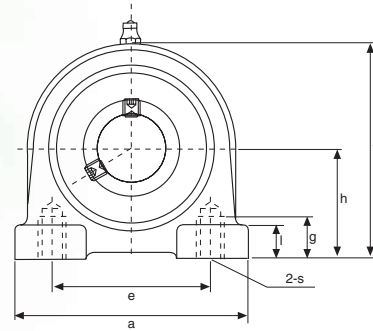

Tipo Type	Dimensioni mm/pollici Dimensions mm/inch										Bull. fiss. Bolt Size mm/inch	Coefficienti di carico (N) Load ratings (N)		Cuscinetto Bearing	Supporto Housing	Peso Weight (kg)
	d	h	a	e	b	g	l	w	B	n		Dinamico C Dynamic C	Statico C <sub>0</sub> Static C <sub>0</sub>			
UCPA201 UCPA201-8	12 3/4	30,2 1 3/16	76 3	52 2 3/4	40 1 9/16	15 1 9/32	11 7/16	62 2 7/16	31 1,2205	12,7 0,500	M10 3/8	12 200	6 350	UC201 UC201-8	PA204	0,60 0,59
UCPA202 UCPA202-9 UCPA202-10	15 9/16 5/8	30,2 1 3/16	76 3	52 2 3/4	40 1 9/16	15 1 9/32	11 7/16	62 2 7/16	31 1,2205	12,7 0,500	M10 3/8	12 200	6 350	UC202 UC202-9 UC202-10	PA204	0,59 0,59 0,59
UCPA203 UCPA203-11	17 1 1/16	30,2 1 3/16	76 3	52 2 3/4	40 1 9/16	15 1 9/32	11 7/16	62 2 7/16	31 1,2205	12,7 0,500	M10 3/8	12 200	6 350	UC203 UC203-11	PA204	0,58 0,57
UCPA204 UCPA204-12	20 3/4	30,2 1 3/16	76 3	52 2 3/4	40 1 9/16	15 1 9/32	11 7/16	62 2 7/16	31 1,2205	12,7 0,500	M10 3/8	12 200	6 350	UC204 UC204-12	PA204	0,56 0,56
UCPA205 UCPA205-13 UCPA205-14 UCPA205-15 UCPA205-16	25 1 3/16 7/8 15/16 1	36,5 1 7/16	84 3 5/16	56 2 1 3/4	38 1 1/2	15 1 9/32	12 15/32	72 2 5 3/4	34,1 1,3425	14,3 0,563	M10 3/8	13 300	7 500	UC205 UC205-13 UC205-14 UC205-15 UC205-16	PA205	0,83 0,87 0,86 0,84 0,83
UCPA206 UCPA206-17 UCPA206-18 UCPA206-19 UCPA206-20	30 1 1/16 1 1/8 1 3/16 1 1/4	42,9 1 11/16	94 3 45/64	66 2 19/32	50 1 31/32	18 45/64	12 15/32	84 3 5/16	38,1 1,5000	15,9 0,626	M14 1/2	18 600	10 800	UC206 UC206-17 UC206-18 UC206-19 UC206-20	PA206	1,12 1,15 1,14 1,12 1,11
UCPA207 UCPA207-20 UCPA207-21 UCPA207-22 UCPA207-23	35 1 1/4 1 5/16 1 3/8 1 7/16	47,6 1 7/8	110 4 2 1/4	80 3 5/8	55 2 1 1/4	20 25/32	13 39/64	95 3 47/64	42,9 1,6890	17,5 0,689	M14 1/2	24 500	14 600	UC207 UC207-20 UC207-21 UC207-22 UC207-23	PA207	1,48 1,54 1,51 1,48 1,45
UCPA208 UCPA208-24 UCPA208-25	40 1 1/2 1 9/16	49,2 1 15/16	116 4 9/16	84 3 5/16	58 2 9/32	20 25/32	13 33/64	100 3 15/16	49,2 1,9370	19 0,748	M14 1/2	27 700	17 000	UC208 UC208-24 UC208-25	PA208	1,89 1,93 1,90
UCPA209 UCPA209-26 UCPA209-27 UCPA209-28	45 1 5/8 1 11/16 1 3/4	54,2 2 9/64	120 4 23/32	90 3 35/64	60 2 23/64	25 63/64	13 39/64	108 4 1/4	49,2 1,9370	19 0,748	M14 1/2	31 000	19 500	UC209 UC209-26 UC209-27 UC209-28	PA209	1,98 2,08 2,04 2,00
UCPA210 UCPA210-29 UCPA210-30 UCPA210-31 UCPA210-32	50 1 13/16 1 7/8 1 15/16 2	57,2 2 1/4	130 5 1/8	94 3 45/64	64 2 33/64	25 63/64	14 35/64	116 4 9/16	51,6 2,0315	19 0,748	M16 5/8	33 500	22 500	UC210 UC210-29 UC210-30 UC210-31 UC210-32	PA210	2,16 2,28 2,23 2,18 2,14
UCPA211 UCPA211-32 UCPA211-33 UCPA211-34 UCPA211-35	55 2 2 1/16 2 1/8 2 3/16	63,5 2 1/2	140 5 3 3/64	104 4 3/8	66 2 19/32	25 63/64	14 35/64	125 4 59/64	55,6 2,1890	22,2 0,874	M16 5/8	41 500	28 000	UC211 UC211-32 UC211-33 UC211-34 UC211-35	PA211	3,26 3,41 3,35 3,30 3,24
UCPA212 UCPA212-36 UCPA212-37 UCPA212-38 UCPA212-39	60 2 1/4 2 5/16 2 3/8 2 7/16	69,9 2 3/4	150 5 29/32	114 4 31/64	68 2 43/64	25 63/64	15 19/32	138 5 7/16	65,1 2,5630	25,4 1,000	M16 5/8	50 000	34 500	UC212 UC212-36 UC212-37 UC212-38 UC212-39	PA212	4,19 4,32 4,24 4,17 4,10
UCPA213 UCPA213-40 UCPA213-41	65 2 1/2 2 9/16	76,2 3	160 6 1 9/64	124 4 7/8	70 2 3/4	25 63/64	15 19/32	150 5 29/32	65,1 2,5630	25,4 1,000	M16 5/8	54 700	38 000	UC213 UC213-40 UC213-41	PA213	- - -



**SUPPORTI RITTI SENZA PIEDI CON BUSSOLA MONTATA**  
**TAPPED BASE PILLOW BLOCKS WITH ADAPTER SLEEVE MOUNTED**

**KDF®**

**UKPA2 Serie normale Normal Series**

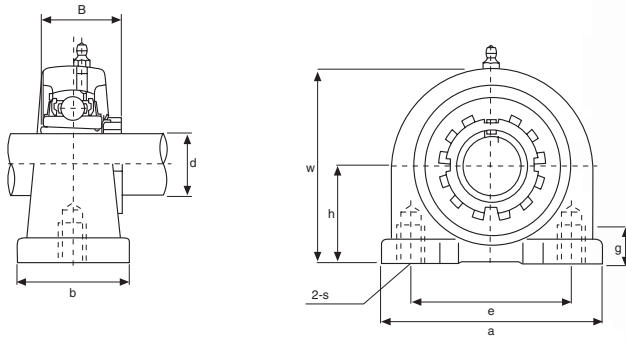

Tipo Type	Dimensioni mm/pollici Dimensions mm/inch								Bull. fiss. Bolt Size mm/inch	Coefficienti di carico (N) Load ratings (N)		Cuscinetto Bearing	Supporto Housing	Peso Weight (kg)
	d	h	a	e	b	g	W	B		Dinamico C Dynamic C	Statico C <sub>0</sub> Static C <sub>0</sub>			
UKPA205+H2305 UKPA205+HE2305	20 3/4	36,5 1 7/16	84 3 5/16	56 2 13/64	38 1 1/2	15 19/32	72 2 53/64	34,1 1,3425	M10 3/8	13 500	7 500	UK205+H2305 UK205+HE2305	PA205	0,87
UKPA206+H2306 UKPA206+HS2306 UKPA206+HE2306	25 7/8 1	42,9 1 11/16	94 3 45/64	66 2 19/32	50 1 31/32	18 45/64	84 3 5/16	38,1 1,5000	M14 1/2	18 600	10 800	UK206+H2306 UK206+HS2306 UK206+HE2306	PA206	1,24
UKPA207+H2307 UKPA207+HS2307	30 1 1/8	47,6 1 7/8	110 4 21/64	80 3 5/32	55 2 11/64	20 25/32	95 3 47/64	42,9 1,6890	M14 1/2	24 500	14 600	UK207+H2307 UK207+HS2307	PA207	1,73
UKPA208+H2308 UKPA208+HE2308 UKPA208+HS2308	35 1 1/4 1 3/8	49,2 1 15/16	116 4 9/16	84 3 5/16	58 2 9/32	20 25/32	100 3 15/16	49,2 1,9370	M14 1/2	27 700	16 900	UK208+H2308 UK208+HE2308 UK208+HS2308	PA208	2,02
UKPA209+H2309 UKPA209+HA2309 UKPA209+HE2309 UKPA209+HS2309	40 1 7/16 1 1/2 1 5/8	54,2 2 9/64	120 4 23/32	90 3 35/64	60 2 23/64	25 63/64	108 4 1/4	49,2 1,9370	M14 1/2	31 000	19 400	UK209+H2309 UK209+HA2309 UK209+HE2309 UK209+HS2309	PA209	2,29
UKPA210+H2310 UKPA210+HS2310 UKPA210+HA2310 UKPA210+HE2310	45 1 5/8 1 11/16 1 3/4	57,2 2 1/4	130 5 1/8	94 3 45/64	64 2 33/64	25 63/64	116 4 9/16	51,6 2,0315	M16 5/8	33 300	22 000	UK210+H2310 UK210+HS2310 UK210+HA2310 UK210+HE2310	PA210	2,89

Bussole HA; HE; HS con filettatura in pollici  
 Inch dimension adapter sleeves HA; HE; HS

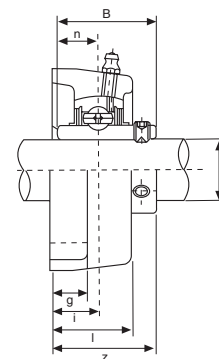
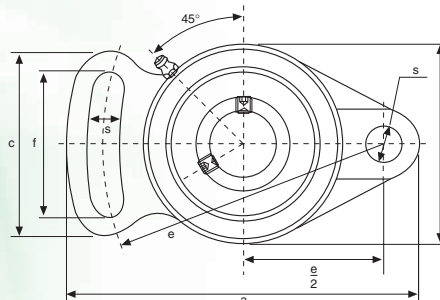

Tipo Type	Dimensioni mm/pollici Dimensions mm/inch												Bull. fiss. Bolt Size mm/inch	Coefficienti di carico (N) Load ratings (N)		Cuscinetto Bearing	Supporto Housing	Peso Weight (kg)	
	d	a	e	i	g	l	s	b	z	f	c	B		n	Dinamico C Dynamic C				Statico C <sub>0</sub> Static C <sub>0</sub>
UCFA201 UCFA201-8	12 3/4	98 355/64	78 39/64	15 19/32	12 15/32	25,5 1	10 25/64	60 29/8	33,3 19/16	40 137/64	50 131/32	31 1,2205	12,7 0,500	M8 5/16	12 200	6 350	UC201 UC201-8	FA204	0,50 0,49
UCFA202 UCFA202-9 UCFA202-10	15 9/16 5/8	98 355/64	78 39/64	15 19/32	12 15/32	25,5 1	10 25/64	60 29/8	33,3 19/16	40 137/64	50 131/32	31 1,2205	12,7 0,500	M8 5/16	12 200	6 350	UC202 UC202-9 UC202-10	FA204	0,49 0,49 0,49
UCFA203 UCFA203-11	17 11/16	98 355/64	78 39/64	15 19/32	12 15/32	25,5 1	10 25/64	60 29/8	33,3 19/16	40 137/64	50 131/32	31 1,2205	12,7 0,500	M8 5/16	12 200	6 350	UC203 UC203-11	FA204	0,48 0,47
UCFA204 UCFA204-12	20 3/4	98 355/64	78 39/64	15 19/32	12 15/32	25,5 1	10 25/64	60 29/8	33,3 19/16	40 137/64	50 131/32	31 1,2205	12,7 0,500	M8 5/16	12 200	6 350	UC204 UC204-12	FA204	0,46 0,46
UCFA205 UCFA205-13 UCFA205-14 UCFA205-15 UCFA205-16	25 13/16 7/8 15/16 1	124 47/8	98 355/64	16 5/8	14 35/64	27 11/16	13 33/64	70 29/4	35,8 113/32	51 21/64	65 29/16	34,1 1,3425	14,3 0,563	M10 3/8	13 300	7 500	UC205 UC205-13 UC205-14 UC205-15 UC205-16	FA205	0,66 0,70 0,69 0,67 0,66
UCFA206 UCFA206-17 UCFA206-18 UCFA206-19 UCFA206-20	30 11/16 1 1/8 13/16 1 1/4	141 535/64	115 417/32	18 45/64	14 35/64	31 17/32	13 33/64	83 317/64	40,2 119/32	58 29/32	72 227/32	38,1 1,5000	15,9 0,626	M10 3/8	18 600	10 800	UC206 UC206-17 UC206-18 UC206-19 UC206-20	FA206	0,93 0,96 0,95 0,93 0,92
UCFA207 UCFA207-20 UCFA207-21 UCFA207-22 UCFA207-23	35 1 1/4 15/16 1 3/8 1 7/16	155 67/64	128 53/64	19 3/4	16 5/8	34 111/32	15 19/32	96 325/32	44,4 13/4	66 219/32	82 315/64	42,9 1,6890	17,5 0,689	M12 7/16	24 500	14 600	UC207 UC207-20 UC207-21 UC207-22 UC207-23	FA207	1,46 1,52 1,49 1,46 1,43
UCFA208 UCFA208-24 UCFA208-25	40 1 1/2 1 1/8	171 47/64	142 519/32	21 53/64	16 5/8	38 1 1/2	15 19/32	105 49/64	51,2 21/64	71 251/64	87 327/64	49,2 1,9370	19 0,748	M12 7/16	27 700	17 000	UC208 UC208-24 UC208-25	FA208	1,78 1,82 1,79
UCFA209 UCFA209-26 UCFA209-27 UCFA209-28	45 15/8 1 11/16 1 3/4	179 73/64	146 53/4	22 55/64	18 45/64	40 137/64	17 43/64	111 43/8	52,2 21/16	72 253/64	90 335/64	49,2 1,9370	19 0,748	M14 1/2	31 000	19 500	UC209 UC209-26 UC209-27 UC209-28	FA209	2,03 2,13 2,09 2,05
UCFA210 UCFA210-29 UCFA210-30 UCFA210-31 UCFA210-32	50 1 13/16 1 7/8 1 15/16 2	189 77/16	155 67/64	22 55/64	18 45/64	40 137/64	17 43/64	116 49/16	54,6 25/32	76 3	94 345/64	51,6 2,0315	19 0,748	M14 1/2	33 500	22 500	UC210 UC210-29 UC210-30 UC210-31 UC210-32	FA210	2,23 2,35 2,30 2,25 2,21
UCFA211 UCFA211-32 UCFA211-33 UCFA211-34 UCFA211-35	55 2 2 1/16 2 1/8 2 3/16	216 8 1/2	182 711/64	25 63/64	20 25/32	44 147/64	17 43/64	133 551/64	58,4 25/16	86 325/64	104 43/32	55,6 2,1890	22,2 0,874	M14 1/2	41 500	28 000	UC211 UC211-32 UC211-33 UC211-34 UC211-35	FA211	3,2 4,5 4,20 4,10 4,00
UCFA212 UCFA212-36 UCFA212-37 UCFA212-38 UCFA212-39	60 2 1/4 25/16 2 3/8 2 7/16	240 929/64	202 761/64	29 19/64	20 25/32	48 1 7/8	19 3/4	140 5 1/2	68,7 223/32	100 315/16	118 441/64	65,1 2,5630	25,4 1,000	M16 5/8	50 000	34 500	UC212 UC212-36 UC212-37 UC212-38 UC212-39	FA212	- - - - -
UCFA213 UCFA213-40 UCFA213-41	65 2 1/2 29/16	250 927/32	210 817/64	30 13/16	20 25/32	50 131/32	19 3/4	155 63/32	69,7 29/4	102 41/64	122 45/64	65,1 2,5630	25,4 1,000	M16 5/8	54 700	38 000	UC213 UC213-40 UC213-41	FA213	- - -

Disponibile in acciaio inox Supporto: AISI 304 - Cuscinetto: AISI 440C  
Disponibile su richiesta con cuscinetto SA (SAFA)

Available stainless steel Housing: AISI 304 - Bearing: AISI 440C  
Available under request with SA bearing (SAFA)





**SUPPORTI A FLANGIA ORIENTABILI CON BUSSOLA MONTATA**  
**ADJUSTABLE FLANGE UNITS WITH ADAPTER SLEEVE MOUNTED**

**KDF®**

**UKFA2 Serie normale Normal Series**

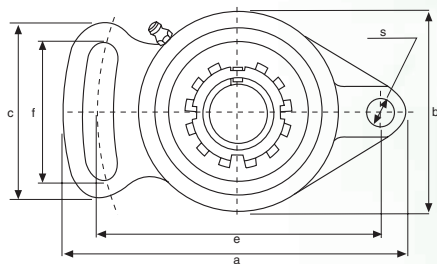
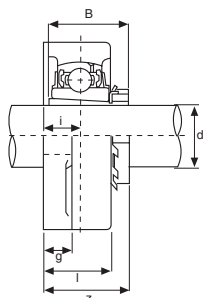

Tipo Type	Dimensioni mm/pollici Dimensions mm/inch												Bull. fiss. Bolt Size mm/inch	Coefficienti di carico (N) Load ratings (N)		Cuscinetto Bearing	Supporto Housing	Peso Weight (kg)
	d	a	e	i	g	l	s	b	z	f	c	B		Dinamico C Dynamic C	Statico C <sub>0</sub> Static C <sub>0</sub>			
UKFA205+H2305 UKFA205+HE2305	20 ¾	124 4 7/8	98 3 55/64	16 5/8	14 35/64	27 1 1/16	13 39/64	70 2 3/4	35,8 1 13/32	51 2 1/64	65 2 9/16	34,1 1,3425	M10 ¾	13 500	7 500	UK205+H2305 UK205+HE2305	FA205	0,71
UKFA206+H2306 UKFA206+HS2306 UKFA206+HE2306	25 7/8 1	141 5 35/64	115 4 17/32	18 45/64	14 35/64	31 1 7/32	13 39/64	83 3 17/64	40,2 1 19/32	58 2 9/32	72 2 27/32	38,1 1,5000	M10 ¾	18 600	10 800	UK206+H2306 UK206+HS2306 UK206+HE2306	FA206	1,04
UKFA207+H2307 UKFA207+HS2307	30 1 1/8	155 6 7/64	128 5 3/64	19 ¾	16 5/8	34 1 11/32	15 19/32	96 3 25/32	44,4 1 ¾	66 2 19/32	82 3 15/64	42,9 1,6890	M12 7/16	24 500	14 600	UK207+H2307 UK207+HS2307	FA207	1,5
UKFA208+H2308 UKFA208+HE2308 UKFA208+HS2308	35 1 1/4 1 3/8	171 47/64	142 5 19/32	21 53/64	16 5/8	38 1 1/2	15 19/32	105 4 9/64	51,2 2 1/64	71 2 51/64	87 3 27/64	49,2 1,9370	M12 7/16	27 700	16 900	UK208+H2308 UK208+HE2308 UK208+HS2308	FA208	1,9
UKFA209+H2309 UKFA209+HA2309 UKFA209+HE2309 UKFA209+HS2309	40 1 7/16 1 1/2 1 5/8	179 7 3/64	146 5 3/4	22 55/64	18 45/64	40 1 37/64	17 43/64	111 4 3/8	52,2 2 1/16	72 2 53/64	90 3 35/64	49,2 1,9370	M14 ½	31 000	19 400	UK209+H2309 UK209+HA2309 UK209+HE2309 UK209+HS2309	FA209	1,8
UKFA210+H2310 UKFA210+HS2310 UKFA210+HA2310 UKFA210+HE2310	45 1 5/8 1 11/16 1 ¾	189 7 7/16	155 6 7/64	22 55/64	18 45/64	40 1 37/64	17 43/64	116 4 9/16	54,6 2 5/32	76 3	94 3 45/64	51,6 2,0315	M14 ½	33 300	22 000	UK210+H2310 UK210+HS2310 UK210+HA2310 UK210+HE2310	FA210	2,1

Bussole HA; HE; HS con filettatura in pollici  
 Inch dimension adapter sleeves HA; HE; HS



### UCFB2 Serie normale Normal Series

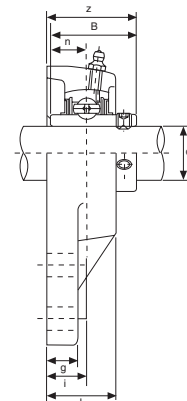
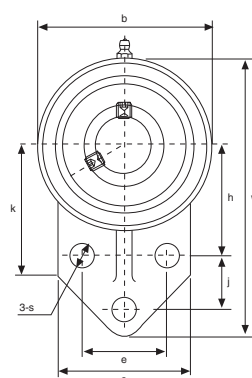

Tipo Type	Dimensioni mm/pollici Dimensions mm/inch															Bull. fiss. Bolt Size mm/inch	Coefficienti di carico (N) Load ratings (N)		Cuscinetto Bearing	Supporto Housing	Peso Weight (kg)
	d	w	b	k	a	l	s	g	h	j	e	i	z	B	n		Dinamico C Dynamic C	Statico C <sub>0</sub> Static C <sub>0</sub>			
UCFB201 UCFB201-8	12 3/4	110 4 1/32	62 2 7/16	52 2 1/16	52 2 1/16	25,5 1	10 25/64	13 1/2	42 1 21/32	27 1 1/16	32 1 17/64	15 19/32	33,3 1 9/16	31 1,2205	12,7 0,500	M8 5/16	12 200	6 350	UC201 UC201-8	FB204	0,58 0,57
UCFB202 UCFB202-9 UCFB202-10	15 9/16 5/8	110 4 1/32	62 2 7/16	52 2 1/16	52 2 1/16	25,5 1	10 25/64	13 1/2	42 1 21/32	27 1 1/16	32 1 17/64	15 19/32	33,3 1 9/16	31 1,2205	12,7 0,500	M8 5/16	12 200	6 350	UC202 UC202-9 UC202-10	FB204	0,57 0,57 0,57
UCFB203 UCFB203-11	17 1 1/16	110 4 1/32	62 2 7/16	52 2 1/16	52 2 1/16	25,5 1	10 25/64	13 1/2	42 1 21/32	27 1 1/16	32 1 17/64	15 19/32	33,3 1 9/16	31 1,2205	12,7 0,500	M8 5/16	12 200	6 350	UC203 UC203-11	FB204	0,56 0,55
UCFB204 UCFB204-12	20 3/4	110 4 1/32	62 2 7/16	52 2 1/16	52 2 1/16	25,5 1	10 25/64	13 1/2	42 1 21/32	27 1 1/16	32 1 17/64	15 19/32	33,3 1 9/16	31 1,2205	12,7 0,500	M8 5/16	12 200	6 350	UC204 UC204-12	FB204	0,54 0,54
UCFB205 UCFB205-13 UCFB205-14 UCFB205-15 UCFB205-16	25 1 3/16 7/8 15/16 1	116 4 9/16	68 2 11/16	52 2 1/16	56 2 7/32	27 1 1/16	10 25/64	13 1/2	45 1 49/64	27 1 1/16	34 1 11/32	16 5/8	35,8 1 13/32	34,1 1,3425	14,3 0,563	M8 5/16	13 300	7 500	UC205 UC205-13 UC205-14 UC205-15 UC205-16	FB205	0,79 0,83 0,82 0,80 0,79
UCFB206 UCFB206-17 UCFB206-18 UCFB206-19 UCFB206-20	30 1 1/16 1 1/8 1 3/16 1 1/4	130 5 1/8	78 3 1/16	55 2 5/32	65 2 9/16	31 1 7/32	10 25/64	13 1/2	50 1 31/32	29 1 9/16	40 1 37/64	18 45/64	40,2 1 19/32	38,1 1,5000	15,9 0,626	M8 5/16	18 600	10 800	UC206 UC206-17 UC206-18 UC206-19 UC206-20	FB206	0,95 0,98 0,97 0,95 0,94
UCFB207 UCFB207-20 UCFB207-21 UCFB207-22 UCFB207-23	35 1 1/4 1 5/16 1 3/8 1 7/16	144 5 21/32	90 3 35/64	62 2 7/16	70 2 3/4	34 1 11/32	10 25/64	15 19/32	55 2 11/64	32 1 17/64	46 1 13/16	19 3/4	44,4 1 3/4	42,9 1,6890	17,5 0,689	M8 5/16	24 500	14 600	UC207 UC207-20 UC207-21 UC207-22 UC207-23	FB207	1,29 1,35 1,32 0,29 1,26
UCFB208 UCFB208-24 UCFB208-25	40 1 1/2 1 9/16	164 6 15/32	100 3 15/16	72 2 27/32	78 3 1/16	36 1 13/32	12 15/32	16 5/8	60 2 23/64	41 1 39/64	50 1 31/32	21 53/64	51,2 2 1/64	49,2 1,9370	19 0,748	M10 3/8	27 700	17 000	UC208 UC208-24 UC208-25	FB208	1,78 1,82 1,79
UCFB209 UCFB209-26 UCFB209-27 UCFB209-28	45 1 5/8 1 11/16 1 3/4	174 6 27/32	106 4 3/16	76 3	80 3 5/32	38 1 1/2	12 15/32	18 23/32	65 2 9/16	43 1 11/16	54 2 1/8	22 55/64	52,2 2 1/16	49,2 1,9370	19 0,748	M10 3/8	31 000	19 500	UC209 UC209-26 UC209-27 UC209-28	FB209	1,91 2,01 1,97 1,93
UCFB210 UCFB210-29 UCFB210-30 UCFB210-31 UCFA210-32	50 1 13/16 1 7/8 1 15/16 2	184 7 1/4	112 4 19/32	82 3 3/8	86 3 37/64	40 1 5/32	12 15/32	18 23/32	68 2 43/64	46 1 13/16	58 2 9/32	22 55/64	54,6 2 5/32	51,6 2,0315	19 0,748	M10 3/8	33 500	22 500	UC210 UC210-29 UC210-30 UC210-31 UC210-32	FB210	2,36 2,48 2,43 2,38 2,34
UCFB211 UCFB211-32 UCFB211-33 UCFB211-34 UCFB211-35	55 2 2 1/16 2 1/8 2 3/16	207 8 5/32	130 5 1/8	86 3 25/64	90 3 35/64	43 1 11/16	14 35/64	18 45/64	78 3 5/16	50 1 31/32	62 2 7/16	25 63/64	58,4 2 5/16	55,6 2,1890	22,2 0,874	M12 7/16	41 500	28 000	UC211 UC211-32 UC211-33 UC211-34 UC211-35	FB211	3,15 3,31 3,25 3,20 3,14
UCFB212 UCFB212-36 UCFB212-37 UCFB212-38 UCFB212-39	60 2 1/4 2 5/16 2 3/8 2 7/16	223 8 25/32	140 5 1/2	90 3 35/64	94 3 45/64	48 1 7/8	14 35/64	18 45/64	84 3 5/16	55 2 11/64	66 2 19/32	29 1 9/64	68,7 2 23/32	65,1 2,5630	25,4 1,000	M12 7/16	50 000	34 500	UC212 UC212-36 UC212-37 UC212-38 UC212-39	FB212	3,99 4,12 4,04 3,97 3,90
UCFB213 UCFB213-40 UCFB213-41	65 2 1/2 2 9/16	244 9 9/64	155 6 7/64	94 3 45/64	100 3 15/16	50 1 13/32	14 35/64	20 25/32	92 3 5/8	60 2 23/64	70 2 3/4	30 1 1/16	69,7 2 3/4	65,1 2,5630	25,4 1,000	M12 7/16	54 700	38 000	UC213 UC213-40 UC213-41	FB213	- - -

Disponibile in acciaio inox Supporto: AISI 304 - Cuscinetto: AISI 440C  
Disponibile su richiesta con cuscinetto SA (SAFB)

Available stainless steel Housing: AISI 304 - Bearing: AISI 440C  
Available under request with SA bearing (SAFB)



## SUPPORTI A FLANGIA CON BUSSOLA MONTATA FLANGE BRACKET UNITS WITH ADAPTER SLEEVE MOUNTED

# KDF®

### UKFB2 Serie normale Normal Series

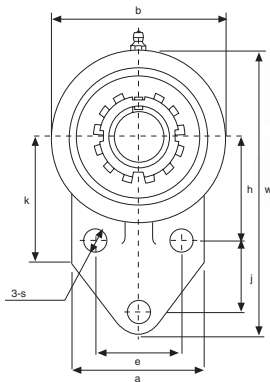
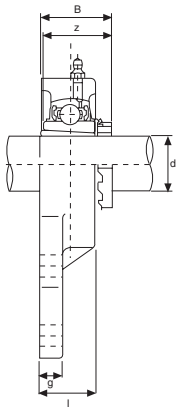

Tipo Type	Dimensioni mm/pollici Dimensions mm/inch															Bull. fiss. Bolt Size mm/inch	Coefficienti di carico (N) Load ratings (N)		Cuscinetto Bearing	Supporto Housing	Peso Weight (kg)
	d	w	b	k	a	l	s	g	h	j	e	i	z	B	Dinamico C Dynamic C		Statico C <sub>0</sub> Static C <sub>0</sub>				
UKFB205+H2305 UKFB205+HE2305	20 3/4	116 4 9/16	68 2 11/16	52 2 1/16	56 2 7/32	27 1 1/16	10 25/64	13 1/2	45 1 49/64	27 1 1/16	34 1 11/32	16 5/8	35,8 1 13/32	34,1 1,3425	M8 5/16	13 500	7 500	UK205+H2305 UK205+HE2305	FB205	0,72	
UKFB206+H2306 UKFB206+HS2306 UKFB206+HE2306	25 7/8 1	130 5 1/8	78 3 1/16	55 2 5/32	65 2 9/16	31 1 7/32	10 25/64	13 1/2	50 1 31/32	29 1 9/64	40 1 37/64	18 45/64	40,2 1 19/32	38,1 1,5000	M8 5/16	18 600	10 800	UK206+H2306 UK206+HS2306 UK206+HE2306	FB206	0,96	
UKFB207+H2307 UKFB207+HS2307	30 1 1/8	144 5 21/32	90 3 35/64	62 2 7/16	70 2 3/4	34 1 11/32	10 25/64	15 19/32	55 2 11/64	32 1 17/64	46 1 13/16	19 3/4	44,4 1 3/4	42,9 1,6890	M8 5/16	24 500	14 600	UK207+H2307 UK207+HS2307	FB207	1,33	
UKFB208+H2308 UKFB208+HE2308 UKFB208+HS2308	35 1 1/4 1 3/8	164 6 15/32	100 3 15/16	72 2 27/32	78 3 1/16	36 1 13/32	12 15/32	16 5/8	60 2 23/64	41 1 39/64	50 1 31/32	21 53/64	51,2 2 1/64	49,2 1,9370	M10 3/8	27 700	16 900	UK208+H2308 UK208+HE2308 UK208+HS2308	FB208	1,82	
UKFB209+H2309 UKFB209+HA2309 UKFB209+HE2309 UKFB209+HS2309	40 1 7/16 1 1/2 1 5/8	174 6 27/32	106 4 3/16	76 3	80 3 5/32	38 1 1/2	12 15/32	18 23/32	65 2 9/16	43 1 11/16	54 2 1/8	22 55/64	52,2 2 1/16	49,2 1,9370	M10 3/8	31 000	19 400	UK209+H2309 UK209+HA2309 UK209+HE2309 UK209+HS2309	FB209	2,09	
UKFB210+H2310 UKFB210+HS2310 UKFB210+HA2310 UKFB210+HE2310	45 1 5/8 1 11/16 1 3/4	184 7 1/4	112 4 13/32	82 3 7/32	86 3 3/8	40 1 37/64	12 15/32	18 23/32	68 2 43/64	46 1 13/16	58 2 9/32	22 55/64	54,6 2 5/32	51,6 2,0315	M10 3/8	33 300	22 000	UK210+H2310 UK210+HS2310 UK210+HA2310 UK210+HE2310	FB210	2,39	

Bussole HA; HE; HS con filettatura in pollici  
Inch dimension adapter sleeves HA; HE; HS



### UCECH2 Serie normale Normal Series

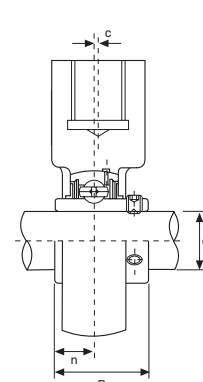
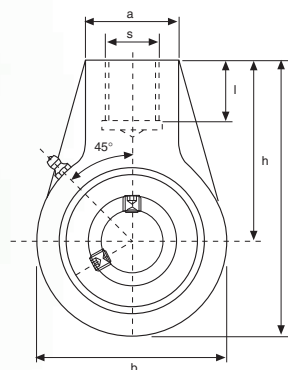

Tipo Type	Dimensioni mm/pollici Dimensions mm/inch										Coefficients di carico (N) Load ratings (N)		Cuscinetto Bearing	Supporto Housing	Peso Weight (kg)
	d	h	w	b	c	a	l	B	n	S	Dinamico C Dynamic C	Statico C <sub>0</sub> Static C <sub>0</sub>			
UCECH201 UCECH201-8	12 3/4	64 2 33/64	96 3 25/32	64 2 33/64	0	40 1 37/64	19 3/4	31 1,2205	12,7 0,500	G 3/4	12 200	6 350	UC201 UC201-8	ECH204	0,73 0,72
UCECH202 UCECH202-9 UCECH202-10	15 5/8	64 2 33/64	96 3 25/32	64 2 33/64	0	40 1 37/64	19 3/4	31 1,2205	12,7 0,500	G 3/4	12 200	6 350	UC202 UC202-9 UC202-10	ECH204	0,72 0,72 0,72
UCECH203 UCECH203-11	17 1 1/16	64 2 33/64	96 3 25/32	64 2 33/64	0	40 1 37/64	19 3/4	31 1,2205	12,7 0,500	G 3/4	12 200	6 350	UC203 UC203-11	ECH204	0,71 0,70
UCECH204 UCECH204-12	20 3/4	64 2 33/64	96 3 25/32	64 2 33/64	0	40 1 37/64	19 3/4	31 1,2205	12,7 0,500	G 3/4	12 200	6 350	UC204 UC204-12	ECH204	0,69 0,69
UCECH205 UCECH205-13 UCECH205-14 UCECH205-15 UCECH205-16	25 1 3/16 7/8 15/16 1	64 2 33/64	103 4 1/16	78 3 5/64	0	40 1 37/64	19 3/4	34,1 1,3425	14,3 0,563	G 3/4	13 300	7 500	UC205 UC205-13 UC205-14 UC205-15 UC205-16	ECH205	0,83 0,87 0,86 0,84 0,83
UCECH206 UCECH206-17 UCECH206-18 UCECH206-19 UCECH206-20	30 1 1/16 1 1/8 1 3/16 1 1/4	64 2 33/64	103 4 1/16	78 3 5/64	0	40 1 37/64	19 3/4	38,1 1,5000	15,9 0,626	G 3/4	18 600	10 800	UC206 UC206-17 UC206-18 UC206-19 UC206-20	ECH206	0,83 0,86 0,85 0,83 0,82
UCECH207 UCECH207-20 UCECH207-21 UCECH207-22 UCECH207-23	35 1 1/4 1 5/16 1 3/8 1 7/16	70 2 3/4	116 4 9/16	92 3 5/8	0	40 1 37/64	19 3/4	42,9 1,6890	17,5 0,689	G 3/4	24 500	14 600	UC207 UC207-20 UC207-21 UC207-22 UC207-23	ECH207	1,16 1,22 1,19 1,16 1,13
UCECH208 UCECH208-24 UCECH208-25	40 1 1/2 1 9/16	73 2 7/8	121 4 49/64	96 3 25/32	2 5/64	40 1 37/64	19 3/4	49,2 1,9370	19 0,748	G 3/4	27 700	17 000	UC208 UC208-24 UC208-25	ECH208	1,32 1,36 1,33
UCECH209 UCECH209-26 UCECH209-27 UCECH209-28	45 1 5/8 1 11/16 1 3/4	82 3 15/64	136 5 23/64	108 4 1/4	5 13/64	48 1 57/64	21 53/64	49,2 1,9370	19 0,748	G 1	31 000	19 500	UC209 UC209-26 UC209-27 UC209-28	ECH209	1,92 2,02 1,98 1,94
UCECH210 UCECH210-29 UCECH210-30 UCECH210-31 UCECH210-32	50 1 13/16 1 7/8 1 15/16 2	83 3 17/64	142 5 19/32	118 4 41/64	5 13/64	48 1 57/64	21 53/64	51,6 2,0315	19 0,748	G 1	33 500	22 500	UC210 UC210-29 UC210-30 UC210-31 UC210-32	ECH210	1,90 2,02 1,97 1,92 1,88
UCECH211 UCECH211-32 UCECH211-33 UCECH211-34 UCECH211-35	55 2 2 1/16 2 1/8 2 3/16	87 3 27/64	150 5 29/32	126 4 61/64	7 9/32	60 2 23/64	25 63/64	55,6 2,1890	22,2 0,874	G 1 1/4	41 500	28 000	UC211 UC211-32 UC211-33 UC211-34 UC211-35	ECH211	2,61 2,76 2,70 2,65 2,59
UCECH212 UCECH212-36 UCECH212-37 UCECH212-38 UCECH212-39	60 2 1/4 2 5/16 2 3/8 2 7/16	102 4 1/64	173 6 13/16	142 5 19/32	9 23/64	60 2 23/64	28 1 7/64	65,1 2,5630	25,4 1,000	G 1 1/4	50 000	34 500	UC212 UC212-36 UC212-37 UC212-38 UC212-39	ECH212	3,54 3,67 3,59 3,52 3,45
UCECH213 UCECH213-40 UCECH213-41	65 2 1/2 2 9/16	117 4 39/64	200 7 7/8	166 6 17/32	9,5 3/8	70 2 3/4	32 1 17/64	65,1 2,5630	25,4 1,000	G 1 1/2	54 700	38 000	UC213 UC213-40 UC213-41	ECH213	5,80 5,89 5,80

Disponibile in acciaio inox Supporto: AISI 304 - Cuscinetto: AISI 440C  
Disponibile su richiesta con cuscinetto SA (SAECH)  
S - Su richiesta disponibili con filetto metrico, in pollici e gas.

Available stainless steel Housing: AISI 304 - Bearing: AISI 440C  
Available under request with SA bearing (SAECH)  
S - Under request available with metric, inches and gas thread.



## SUPPORTI PENSILI CON BUSSOLA MONTATA HANGER BEARING UNITS WITH ADAPTER SLEEVE MOUNTED

# KDF®

### UKECH2 Serie normale Normal Series

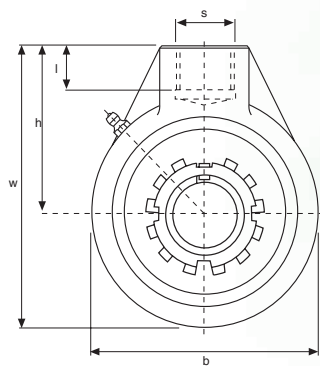
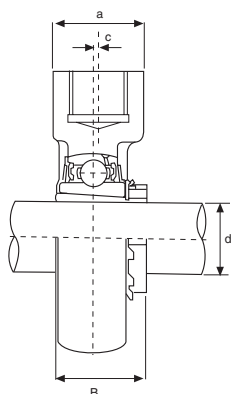

Tipo Type	Dimensioni mm/pollici Dimensions mm/inch									Coefficienti di carico (N) Load ratings (N)		Cuscinetto Bearing	Supporto Housing	Peso Weight (kg)
	d	h	w	b	c	a	l	B	S	Dinamico C Dynamic C	Statico C <sub>0</sub> Static C <sub>0</sub>			
UKECH205+H2305 UKECH205+HE2305	20 3/4	64 2 <sup>33</sup> / <sub>64</sub>	103 4 <sup>1</sup> / <sub>16</sub>	78 3 <sup>5</sup> / <sub>64</sub>	0	40 1 <sup>37</sup> / <sub>64</sub>	19 3/4	34,1 1,3425	G <sup>3</sup> / <sub>4</sub>	13 500	7 500	UK205+H2305 UK205+HE2305	ECH205	0,9
UKECH206+H2306 UKECH206+HS2306 UKECH206+HE2306	25 7/8 1	64 2 <sup>33</sup> / <sub>64</sub>	103 4 <sup>1</sup> / <sub>16</sub>	78 3 <sup>5</sup> / <sub>64</sub>	0	40 1 <sup>37</sup> / <sub>64</sub>	19 3/4	38,1 1,5000	G <sup>3</sup> / <sub>4</sub>	18 600	10 800	UK206+H2306 UK206+HS2306 UK206+HE2306	ECH206	0,9
UKECH207+H2307 UKECH207+HS2307	30 1 <sup>1</sup> / <sub>8</sub>	70 2 <sup>3</sup> / <sub>4</sub>	116 4 <sup>9</sup> / <sub>16</sub>	92 3 <sup>5</sup> / <sub>8</sub>	0	40 1 <sup>37</sup> / <sub>64</sub>	19 3/4	42,9 1,6890	G <sup>3</sup> / <sub>4</sub>	24 500	14 600	UK207+H2307 UK207+HS2307	ECH207	1,23
UKECH208+H2308 UKECH208+HE2308 UKECH208+HS2308	35 1 <sup>1</sup> / <sub>4</sub> 1 <sup>3</sup> / <sub>8</sub>	73 2 <sup>7</sup> / <sub>8</sub>	121 4 <sup>49</sup> / <sub>64</sub>	96 3 <sup>25</sup> / <sub>32</sub>	2 5/64	40 1 <sup>37</sup> / <sub>64</sub>	19 3/4	49,2 1,9370	G <sup>3</sup> / <sub>4</sub>	27 700	16 900	UK208+H2308 UK208+HE2308 UK208+HS2308	ECH208	1,32
UKECH209+H2309 UKECH209+HA2309 UKECH209+HE2309 UKECH209+HS2309	40 1 <sup>7</sup> / <sub>16</sub> 1 <sup>1</sup> / <sub>2</sub> 1 <sup>5</sup> / <sub>8</sub>	82 3 <sup>15</sup> / <sub>64</sub>	136 5 <sup>23</sup> / <sub>64</sub>	108 4 <sup>1</sup> / <sub>4</sub>	5 1 <sup>3</sup> / <sub>64</sub>	48 1 <sup>57</sup> / <sub>64</sub>	21 5 <sup>3</sup> / <sub>64</sub>	49,2 1,9370	G1	31 000	19 400	UK209+H2309 UK209+HA2309 UK209+HE2309 UK209+HS2309	ECH209	1,79
UKECH210+H2310 UKECH210+HS2310 UKECH210+HA2310 UKECH210+HE2310	45 1 <sup>5</sup> / <sub>8</sub> 1 <sup>11</sup> / <sub>16</sub> 1 <sup>3</sup> / <sub>4</sub>	83 3 <sup>17</sup> / <sub>64</sub>	142 5 <sup>19</sup> / <sub>32</sub>	118 4 <sup>41</sup> / <sub>64</sub>	5 1 <sup>3</sup> / <sub>64</sub>	48 1 <sup>57</sup> / <sub>64</sub>	21 5 <sup>3</sup> / <sub>64</sub>	51,6 2,0315	G1	33 300	22 000	UK210+H2310 UK210+HS2310 UK210+HA2310 UK210+HE2310	ECH210	2,19
UKECH211+H2311 UKECH211+HS2311 UKECH211+HA2311 UKECH211+HE2311	50 1 <sup>7</sup> / <sub>8</sub> 1 <sup>15</sup> / <sub>16</sub> 2	87 3 <sup>27</sup> / <sub>64</sub>	150 5 <sup>29</sup> / <sub>32</sub>	126 4 <sup>61</sup> / <sub>64</sub>	7 9/32	60 2 <sup>23</sup> / <sub>64</sub>	25 6 <sup>3</sup> / <sub>64</sub>	55,6 2,1890	G1 <sup>1</sup> / <sub>4</sub>	41 400	27 800	UK211+H2311 UK211+HS2311 UK211+HA2311 UK211+HE2311	ECH211	2,84
UKECH212+H2312 UKECH212+HS2312	55 2 <sup>1</sup> / <sub>8</sub>	102 4 <sup>1</sup> / <sub>64</sub>	173 6 <sup>13</sup> / <sub>16</sub>	142 5 <sup>19</sup> / <sub>32</sub>	9 2 <sup>3</sup> / <sub>64</sub>	60 2 <sup>23</sup> / <sub>64</sub>	28 1 <sup>7</sup> / <sub>64</sub>	65,1 2,5630	G1 <sup>1</sup> / <sub>4</sub>	49 900	34 200	UK212+H2312 UK212+HS2312	ECH211	3,81

Bussole HA; HE; HS con filettatura in pollici  
Inch dimension adapter sleeves HA; HE; HS

S - Su richiesta disponibili con filetto metrico, in pollici e gas.  
S - Under request available with metric, inches and gas thread.

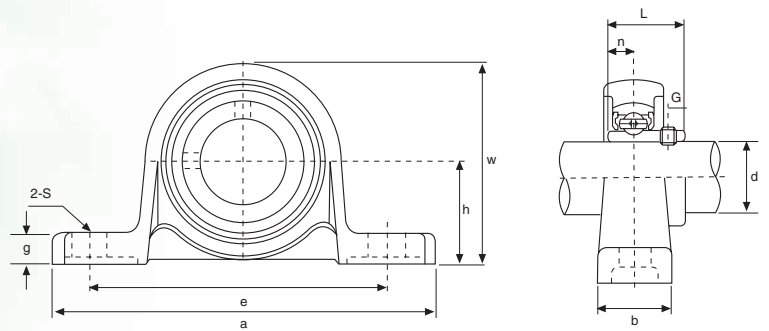
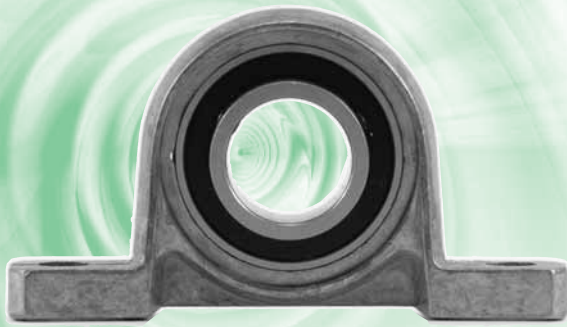

Tipo Type	Dimensioni mm Dimensions mm											Bull. fiss. Bolt Size mm	Coefficienti di carico (N) Load ratings (N)		Cuscinetto Bearing	Supporto Housing	Peso Weight (kg)
	d	h	a	e	b	s	g	w	L	n	G		Dinamico C Dynamic C	Statico C <sub>0</sub> Static C <sub>0</sub>			
UP000	10	18	67	53	16	7	6	35	14	4	4	M6	470	200	U000	LP000	0,077
UP001	12	19	71	56	16	7	6	38	17,5	4	4	M6	520	245	U001	LP001	0,091
UP002	15	22	80	63	16	6	7	43	18,5	4,5	4	M6	570	290	U002	LP002	0,125
UP003	17	24	85	67	18	6	7	47	20,5	5	4	M6	610	335	U003	LP003	0,156
UP004	20	28	100	80	20	10	9	55	24,5	6	4,5	M8	955	515	U004	LP004	0,230
UP005	25	32	112	90	20	10	10	62	25,5	6	5	M8	1030	595	U005	LP005	0,294
UP006	30	36	132	106	26	13	11	70	26,5	6,5	5	M10	1350	845	U006	LP006	0,454
UP007	35	40	150	118	26	13	13	80	29,5	7	6	M10	1475	975	U007	LP007	0,593

Disponibile su richiesta in acciaio inox supporto: AISI 304 - Cuscinetto: AISI 440C - Available under request stainless steel housing: AISI 304 - Bearing: AISI 440C  
Su richiesta fornibili anche con anello di serraggio eccentrico - Under request available with eccentric collar locking

## SUPPORTI A FLANGIA OVALE OVAL FLANGE UNITS

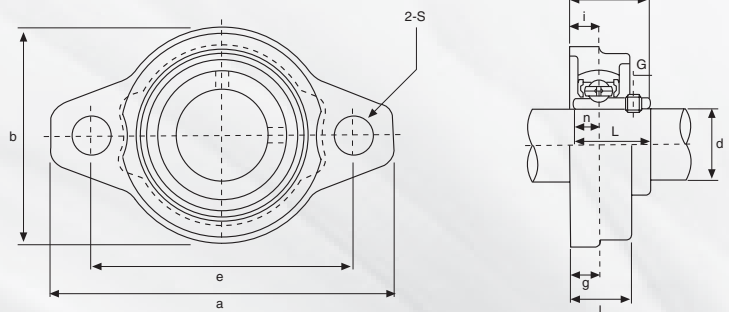

Tipo Type	Dimensioni mm Dimensions mm											Bull. fiss. Bolt Size mm	Coefficienti di carico (N) Load ratings (N)		Cuscinetto Bearing	Supporto Housing	Peso Weight (kg)	
	d	a	e	i	g	l	s	b	Z	L	n		G	Dinamico C Dynamic C				Statico C <sub>0</sub> Static C <sub>0</sub>
UFL000	10	60	45	5,5	5,5	11,5	7	36	15,5	14	4	4	M6	470	200	U000	FL000	0,063
UFL001	12	63	48	5,5	5,5	11,5	7	38	19	17,5	4	4	M6	520	245	U001	FL001	0,076
UFL002	15	67	53	6,5	6,5	13	7	42	20,5	18,5	4,5	4	M6	570	290	U002	FL002	0,100
UFL003	17	71	56	7	7	14	7	46	22,5	20,5	5	4	M6	610	335	U003	FL003	0,129
UFL004	20	90	71	8	8	16	10	55	26,5	24,5	6	4,5	M8	955	515	U004	FL004	0,205
UFL005	25	95	75	8	8	16	10	60	27,5	25,5	6	5	M8	1030	595	U005	FL005	0,244
UFL006	30	112	85	9	9	18	13	70	29,5	26,5	6,5	5	M10	1350	845	U006	FL006	0,354
UFL007	35	122	95	10	10	20	13	80	32,5	29,5	7	6	M10	1475	975	U007	FL007	0,498

Disponibile su richiesta in acciaio inox supporto: AISI 304 - Cuscinetto: AISI 440C - Available under request stainless steel housing: AISI 304 - Bearing: AISI 440C  
Su richiesta fornibili anche con anello di serraggio eccentrico - Under request available with eccentric collar locking

Supporti in serie leggera in lega d'alluminio, fissaggio con grani ed a richiesta con anello eccentrico di serraggio. Un nuovo concetto di supporto; offre una significativa riduzione di peso ed ingombro rispetto alle normali serie, con risparmio economico nella progettazione di macchine.  
Extra light duty bearing units available with set screws at request by eccentric collar locking, a totally new concept in bearing units, offer a significant reduction in size and weight when compared with the same size of existing series. This unique design promotes both space and material saving in machine tool and general equipment application.



# SUPPORTI A FLANGIA OVALE OVAL FLANGE UNITS



## SAFD2 - SBFD2

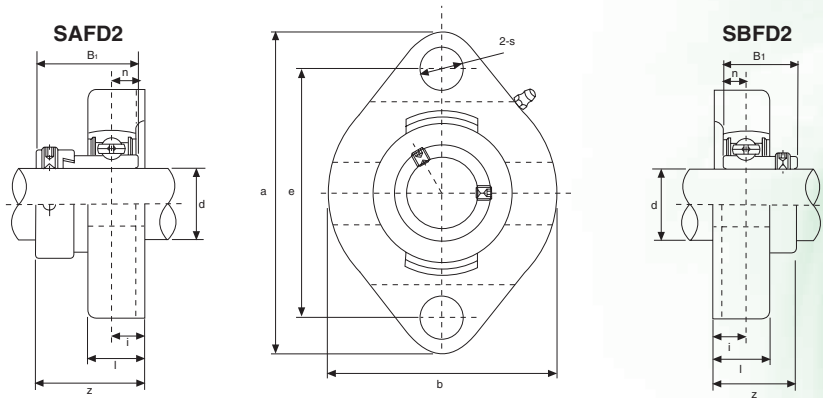

Tipo Type	Dimensioni mm/pollici Dimensions mm/inch							Bull. fiss. Bolt Size mm/inch	SAFD			Cuscinetto Bearing	Peso Weight (kg)	SBFD			Cuscinetto Bearing	Peso Weight (kg)	Supporto Housing	Coefficienti di carico (N) Load ratings (N)	
	d	a	e	b	i	s	l		z	$B_1$	n			z	$B_1$	n				Dinamico C Dynamic C	Statico $C_0$ Static $C_0$
SAFD-SBFD 201 201-8	12 $\frac{3}{4}$	81 $3\frac{1}{16}$	63 $2\frac{3}{16}$	59 $2\frac{1}{4}$	8,5 $2\frac{1}{4}$	7 $\frac{9}{32}$	15 $1\frac{9}{32}$	M6 $\frac{1}{4}$	30,6 $1\frac{13}{64}$	28,6 1,1260	6,5 0,2559	SA201 SA201-8	0,3	24 $\frac{61}{64}$	22 0,8661	6 0,2362	SB201 SB201-8	0,3	FD203	9 200	4 480
SAFD-SBFD 202 202-9 202-10	15 $\frac{9}{16}$ $\frac{5}{8}$	81 $3\frac{1}{16}$	63 $2\frac{3}{16}$	59 $2\frac{1}{4}$	8,5 $2\frac{1}{4}$	7 $\frac{9}{32}$	15 $1\frac{9}{32}$	M6 $\frac{1}{4}$	30,6 $1\frac{13}{64}$	28,6 1,1260	6,5 0,2559	SA202 SA202-9 SA202-10	0,3	24 $\frac{61}{64}$	22 0,8661	6 0,2362	SB202 SB202-9 SB202-10	0,3	FD203	9 200	4 480
SAFD-SBFD 203 203-11	17 $1\frac{1}{16}$	81 $3\frac{1}{16}$	63 $2\frac{3}{16}$	59 $2\frac{1}{4}$	8,5 $2\frac{1}{4}$	7 $\frac{9}{32}$	15 $1\frac{9}{32}$	M6 $\frac{1}{4}$	30,6 $1\frac{13}{64}$	28,6 1,1260	6,5 0,2559	SA203 SA203-11	0,3	24 $\frac{61}{64}$	22 0,8661	6 0,2362	SB203 SB203-11	0,3	FD203	9 200	4 480
SAFD-SBFD 204 204-12	20 $\frac{3}{4}$	90 $3\frac{39}{64}$	71 $2\frac{5}{16}$	67 $2\frac{41}{64}$	9,5 $\frac{3}{8}$	10 $\frac{25}{64}$	17 $\frac{43}{64}$	M8 $\frac{5}{16}$	33 $1\frac{19}{64}$	31 1,2204	7,5 0,2953	SA204 SA204-12	0,5	27,5 $1\frac{5}{16}$	25 0,9843	7 0,2756	SB204 SB204-12	0,4	FD204	12 200	6 300
SAFD-SBFD 205 205-13 205-14 205-15 205-16	25 $\frac{13}{16}$ $\frac{7}{8}$ $\frac{15}{16}$ 1	95 $3\frac{3}{4}$	76 $2\frac{63}{64}$	71 $2\frac{51}{64}$	9,5 $\frac{3}{8}$	10 $\frac{25}{64}$	17 $\frac{43}{64}$	M8 $\frac{5}{16}$	33 $1\frac{19}{64}$	31 1,2204	7,5 0,2953	SA205 SA205-13 SA205-14 SA205-15 SA205-16	0,5	29 $1\frac{1}{64}$	27 1,0630	7,5 0,2953	SB205 SB205-13 SB205-14 SB205-15 SB205-16	0,5	FD205	13 300	7 460
SAFD-SBFD 206 206-17 206-18 206-19 206-20	30 $1\frac{1}{16}$ $1\frac{1}{8}$ $1\frac{3}{16}$ $1\frac{1}{4}$	113 $4\frac{7}{16}$	90 $3\frac{35}{64}$	84 $3\frac{51}{64}$	12 $1\frac{5}{32}$	12 $1\frac{5}{32}$	21 $\frac{53}{64}$	M10 $\frac{3}{8}$	38,7 $1\frac{17}{32}$	35,7 1,4055	9 0,3543	SA206 SA206-17 SA206-18 SA206-19 SA206-20	0,8	34 $1\frac{11}{32}$	30 1,1811	8 0,3150	SB206 SB206-17 SB206-18 SB206-19 SB206-20	0,8	FD206	18 500	10 800
SAFD-SBFD 207 207-20 207-21 207-22 207-23	35 $1\frac{1}{4}$ $1\frac{5}{16}$ $1\frac{3}{8}$ $1\frac{7}{16}$	125 $4\frac{59}{64}$	100 $3\frac{15}{16}$	94 $3\frac{45}{64}$	12,5 $\frac{1}{2}$	12 $1\frac{5}{32}$	22 $\frac{7}{8}$	M10 $\frac{3}{8}$	41,9 $1\frac{21}{32}$	38,9 1,5315	9,5 0,3740	SA207 SA207-20 SA207-21 SA207-22 SA207-23	1,0	36 $1\frac{27}{64}$	32 1,2598	8,5 0,3346	SB207 SB207-20 SB207-21 SB207-22 SB207-23	0,9	FD207	24 500	14 600

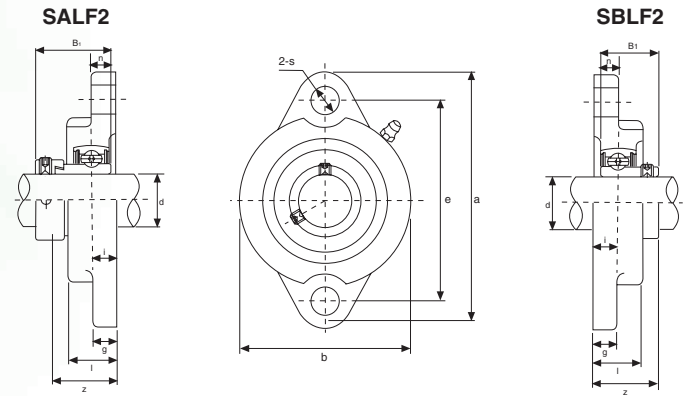

Tipo Type	Dimensioni mm/pollici Dimensions mm/inch								Bull. fiss. Bolt Size mm/inch	SALF			Cuscinetto Bearing	Peso Weight (kg)	SBLF			Cuscinetto Bearing	Peso Weight (kg)	Supporto Housing	Coefficienti di carico (N) Load ratings (N)	
	d	a	e	b	i	s	g	l		z	B <sub>1</sub>	n			z	B <sub>1</sub>	n				Dinamico C Dynamic C	Statico C <sub>0</sub> Static C <sub>0</sub>
SALF-SBLF 201 201-8	12 3/4	81 3 3/16	63,5 2 1/2	56 2 1 3/64	9,5 3/8	8 5/16	9,5 3/8	18 4 5/64	M6 1/4	31,6 1 1/4	28,6 1,1260	6,5 0,2559	SA201 SA201-8	0,3	25,5 1	22 0,8661	6 0,2362	SB201 SB201-8	0,3	LF203	9 200	4 480
SALF-SBLF 202 202-9 202-10	15 9/16 5/8	81 3 3/16	63,5 2 1/2	56 2 1 3/64	9,5 3/8	8 5/16	9,5 3/8	18 4 5/64	M6 1/4	31,6 1 1/4	28,6 1,1260	6,5 0,2559	SA202 SA202-9 SA202-10	0,3	25,5 1	22 0,8661	6 0,2362	SB202 SB202-9 SB202-10	0,3	LF203	9 200	4 480
SALF-SBLF 203 203-11	17 1 1/16	81 3 3/16	63,5 2 1/2	56 2 1 3/64	9,5 3/8	8 5/16	9,5 3/8	18 4 5/64	M6 1/4	31,6 1 1/4	28,6 1,1260	6,5 0,2559	SA203 SA203-11	0,3	25,5 1	22 0,8661	6 0,2362	SB203 SB203-11	0,3	LF203	9 200	4 480
SALF-SBLF 204 204-12	20 3/4	90 3 3 5/64	71,5 2 1 3/16	61 2 1 3/32	11 7/16	10 2 5/64	11 7/16	20 2 5/32	M8 5/16	34,5 1 2 3/64	31 1,2204	7,5 0,2953	SA204 SA204-12	0,4	29 1 9/64	25 0,9843	7 0,2756	SB204 SB204-12	0,3	LF204	12 200	6 300
SALF-SBLF 205 205-13 205-14 205-15 205-16	25 1 3/16 7/8 1 5/16 1	95 3 3/4	76 2 5 3/64	64 2 3 3/64	11 7/16	10 2 5/64	11 7/16	20 2 5/32	M8 5/16	34,5 1 2 3/64	31 1,2204	7,5 0,2953	SA205 SA205-13 SA205-14 SA205-15 SA205-16	0,5	30,5 1 1 3/64	27 1,0630	7,5 0,2953	SB205 SB205-13 SB205-14 SB205-15 SB205-16	0,4	LF205	13 300	7 460
SALF-SBLF 206 206-17 206-18 206-19 206-20	30 1 1/16 1 1/8 1 1/16 1 1/4	113 4 7/16	90,5 3 3 3/16	76 3	12 1 5/32	12 1 5/32	12 1 5/32	22,5 5 7/64	M10 3/8	38,7 1 3 3/64	35,7 1,4055	9 0,3543	SA206 SA206-17 SA206-18 SA206-19 SA206-20	0,7	34 1 1 1/32	30 1,1811	8 0,3150	SB206 SB206-17 SB206-18 SB206-19 SB206-20	0,6	LF206	18 500	10 800
SALF-SBLF 207 207-20 207-21 207-22 207-23	35 1 1/4 1 5/16 1 3/8 1 7/16	122 4 1 3/16	100 3 1 5/16	89 3 1/2	13 3 3/64	12 1 5/32	13 3 3/64	24 6 1/64	M10 3/8	42,4 1 4 3/64	38,9 1,5315	9,5 0,3740	SA207 SA207-20 SA207-21 SA207-22 SA207-23	0,9	36,5 1 7/16	32 1,2598	8,5 0,3346	SB207 SB207-20 SB207-21 SB207-22 SB207-23	0,8	LF207	24 500	14 600





# SUPPORTI AGRICOLI AGRICULTURAL BEARING UNITS

# KDF®

## ST Serie normale Normal Series

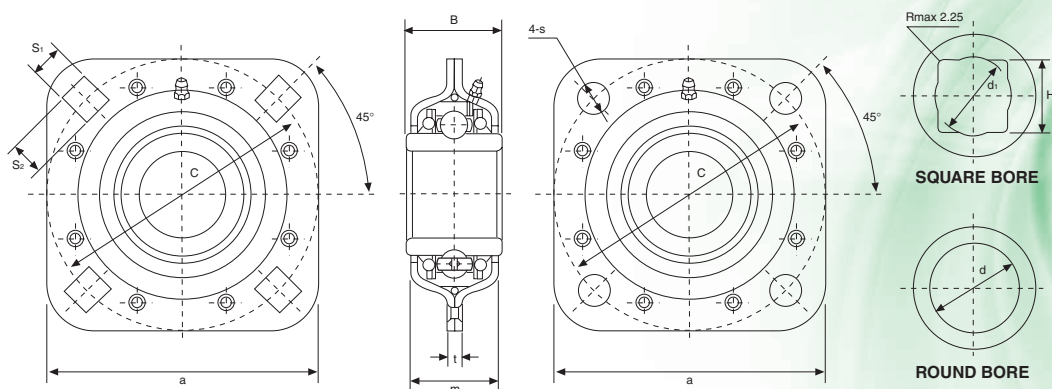

Tipo Type	Dimensioni mm Dimensions mm											Coefficienti di carico (N) Load ratings (N)	
	H	d	a	B	m	t	C	s	s <sub>1</sub>	s <sub>2</sub>	d <sub>1</sub>	Dinamico C Dynamic C	Statico C <sub>0</sub> Static C <sub>0</sub>
ST209-1 <sup>1</sup> / <sub>8</sub>	29,972	-	127	42,8	42	6	127	13,5	13,5	17,45	32,0	24 360	17 710
ST209-30S	31,353	-	127	42,8	42	6	127	13,5	13,5	17,45	34,5	24 360	17 710
ST209-1 <sup>1</sup> / <sub>4</sub>	32,766	-	127	42,8	42	6	127	13,5	13,5	17,45	34,5	24 360	17 710
ST491B	-	38,860	127	42,8	42	6	127	13,5	13,5	17,45	-	24 360	17 710
ST209-40R	-	40,878	127	42,8	42	6	127	13,5	13,5	17,45	-	24 360	17 710
ST491A	-	45,000	127	42,8	42	6	127	13,5	13,5	17,45	-	24 360	17 710
ST209-45R	-	45,340	127	42,8	42	6	127	13,5	13,5	17,45	-	24 360	17 710
ST491A <sup>1)</sup>	-	45,000	121	46	42	6	121	13,5	-	-	-	24 360	17 710
ST211-1 <sup>1</sup> / <sub>2</sub>	38,890	-	139,7	50,8	46	8	139,7	13,5	13,5	17,45	42,0	33 370	25 110
ST211-40S	40,878	-	139,7	50,8	46	8	139,7	13,5	13,5	17,45	43,1	33 370	25 110
ST211-50R	-	50,400	139,7	50,8	46	8	139,7	13,5	13,5	17,45	-	33 370	25 110
ST211-55R	-	55,575	139,7	50,8	46	8	139,7	13,5	13,5	17,45	-	33 370	25 110
ST211-1 <sup>3</sup> / <sub>4</sub>	-	45,212	139,7	55,6	46	8	139,7	13,5	13,5	17,45	-	33 370	25 110
ST211-2 <sup>3</sup> / <sub>16</sub>	-	55,575	139,7	55,6	46	8	139,7	13,5	13,5	17,45	-	33 370	25 110
ST211-1 <sup>15</sup> / <sub>16</sub>	-	49,238	139,7	69,9	46	8	139,7	13,5	13,5	17,45	-	33 370	25 110
ST211	-	55,000	139,7	69,9	46	8	139,7	13,5	13,5	17,45	-	33 370	25 110
ST740	-	55,562	139,7	55,6	45	7	139,7	13,5	13,5	17,45	-	33 370	25 110

<sup>1)</sup> Dimensioni speciali - Special dimensions

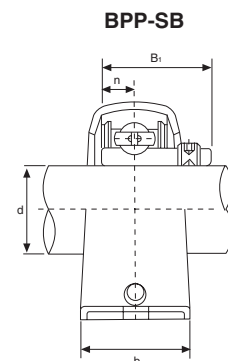
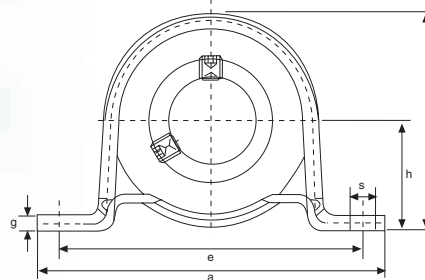
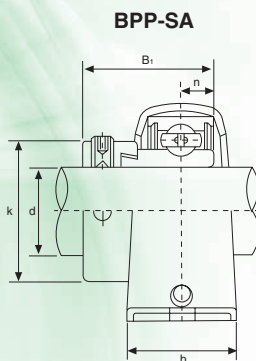
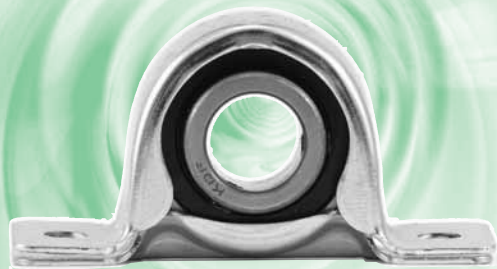

Tipo Type	Dimensioni mm/pollici Dimensions mm/inch								Bull. fiss. Bolt Size mm/inch	BPP-SA		Cuscinetto Bearing	Peso Weight (kg)	BPP-SB		Cuscinetto Bearing	Peso Weight (kg)	Supporto Housing	Coefficienti di carico (N) Load ratings (N)	
	d	h	a	e	b	s	g	w		B <sub>1</sub>	n			B <sub>1</sub>	n				Dinamico C <sub>D</sub>	Statico C <sub>S</sub>
BPP-SA BPP-SB 201 201-8	12 3/4	22,2 7/8	86 3 3/8	68 2 3/4	25 6 3/4	9,5 3/8	3,2 0,126	43,8 1 23/32	M8 5/16	28,6 1,1260	6,5 0,2559	SA201 SA201-8	0,19	22 0,8661	6 0,2362	SB201 SB201-8	0,19	PP203	9 200	4 480
BPP-SA BPP-SB 202 202-9 202-10	15 9/16 5/8	22,2 7/8	86 3 3/8	68 2 3/4	25 6 3/4	9,5 3/8	3,2 0,126	43,8 1 23/32	M8 5/16	28,6 1,1260	6,5 0,2559	SA202 SA202-9 SA202-10	0,19	22 0,8661	6 0,2362	SB202 SB202-9 SB202-10	0,19	PP203	9 200	4 480
BPP-SA BPP-SB 203 203-11	17 1 1/16	22,2 7/8	86 3 3/8	68 2 3/4	25 6 3/4	9,5 3/8	3,2 0,126	43,8 1 23/32	M8 5/16	28,6 1,1260	6,5 0,2559	SA203 SA203-11	0,19	22 0,8661	6 0,2362	SB203 SB203-11	0,19	PP203	9 200	4 480
BPP-SA BPP-SB 204 204-12	20 3/4	25,4 1	98 3 27/32	76 2 53/64	32 1 1/4	9,5 3/8	3,2 0,126	50,5 1 63/64	M8 5/16	31 1,2204	7,5 0,2953	SA204 SA204-12	0,23	25 0,9843	7 0,2756	SB204 SB204-12	0,23	PP204	12 200	6 300
BPP-SA BPP-SB 205 205-13 205-14 205-15 205-16	25 1 3/16 7/8 15/16 1	28,6 1 1/8	108 4 1/4	86 3 25/64	32 1 1/4	11,5 29/64	4 0,157	56,6 2 15/64	M10 3/8	31 1,2204	7,5 0,2953	SA205 SA205-13 SA205-14 SA205-15 SA205-16	0,32	27 1,0630	7,5 0,2953	SB205 SB205-13 SB205-14 SB205-15 SB205-16	0,28	PP205	13 300	7 460
BPP-SA BPP-SB 206 206-17 206-18 206-19 206-20	30 1 1/16 1 1/8 1 3/16 1 1/4	33,3 1 5/16	117 4 39/64	95 3 47/64	38 1 1/2	11,5 29/64	4 0,157	66,3 2 39/64	M10 3/8	35,7 1,4055	9 0,3543	SA206 SA206-17 SA206-18 SA206-19 SA206-20	0,50	30 1,1811	8 0,3150	SB206 SB206-17 SB206-18 SB206-19 SB206-20	0,47	PP206	18 500	10 800
BPP-SA BPP-SB 207 207-20 207-21 207-22 207-23	35 1 1/4 1 5/16 1 3/8 1 7/16	39,7 1 9/16	129 5 1/8	106 4 1/2	42 1 21/32	11,5 29/64	4,6 0,181	78 3 1/8	M10 3/8	38,9 1,5315	9,5 0,3740	SA207 SA207-20 SA207-21 SA207-22 SA207-23	0,71	32 1,2598	8,5 0,3346	SB207 SB207-20 SB207-21 SB207-22 SB207-23	0,57	PP207	24 500	14 600

Disponibile in acciaio inox Supporto: AISI 304 - Cuscinetto: AISI 440C  
Available stainless steel Housing: AISI 304 - Bearing: AISI 440C



# SUPPORTI A FLANGIA TONDA IN LAMIERA STAMPATA PRESSED STEEL FLANGE UNITS



## BPF2-SA - BPF2-SB Serie leggera Light Series

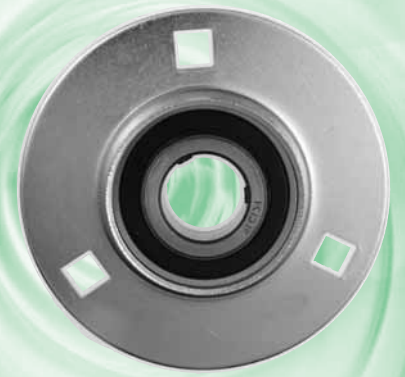
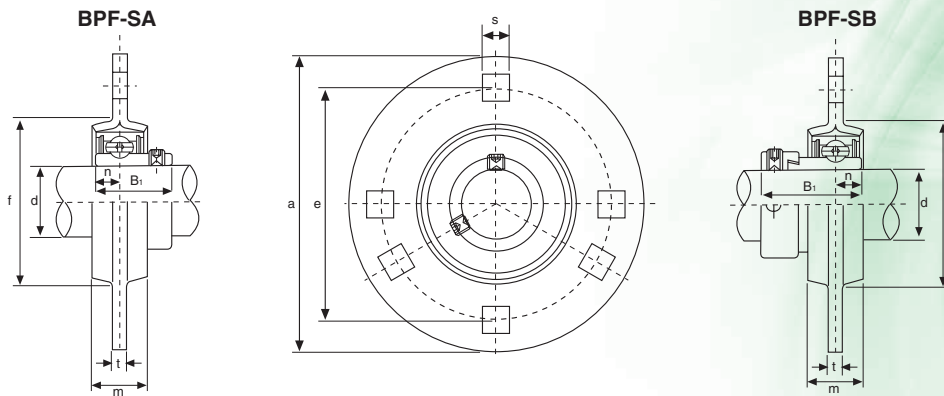

Tipo Type	Dimensioni mm/pollici Dimensions mm/inch							Bull. fiss. Bolt Size mm/inch	BPF-SA		Cuscinetto Bearing	Peso Weight (kg)	BPF-SB		Cuscinetto Bearing	Peso Weight (kg)	Supporto Housing	Coefficienti di carico (N) Load ratings (N)	
	d	a	e	m	s	t	f (min)		B <sub>1</sub>	n			B <sub>1</sub>	n				Dinamico C Dynamic C	Statico C <sub>0</sub> Static C <sub>0</sub>
<b>BPF-SA</b> <b>BPF-SB</b> 201 201-8	12 3/4	81 3 3/16	63,5 2 1/2	14 9/16	7,1 9/32	4 0,157	49 1 59/64	M6 1/4	28,6 1,1260	6,5 0,2559	SA201 SA201-8	0,3	22 0,8661	6 0,2362	SB201 SB201-8	0,27	PF203	9 200	4 480
<b>BPF-SA</b> <b>BPF-SB</b> 202 202-9 202-10	15 9/16 5/8	81 3 3/16	63,5 2 1/2	14 9/16	7,1 9/32	4 0,157	49 1 59/64	M6 1/4	28,6 1,1260	6,5 0,2559	SA202 SA202-9 SA202-10	0,3	22 0,8661	6 0,2362	SB202 SB202-9 SB202-10	0,27	PF203	9 200	4 480
<b>BPF-SA</b> <b>BPF-SB</b> 203 203-11	17 1 1/16	81 3 3/16	63,5 2 1/2	14 9/16	7,1 9/32	4 0,157	49 1 59/64	M6 1/4	28,6 1,1260	6,5 0,2559	SA203 SA203-11	0,3	22 0,8661	6 0,2362	SB203 SB203-11	0,27	PF203	9 200	4 480
<b>BPF-SA</b> <b>BPF-SB</b> 204 204-12	20 3/4	90 3 5/8	71,5 2 13/16	16 5/8	9 23/32	4 0,157	56 2 13/64	M8 5/16	31 1,2204	7,5 0,2953	SA204 SA204-12	0,33	25 0,9843	7 0,2756	SB204 SB204-12	0,33	PF204	12 200	6 300
<b>BPF-SA</b> <b>BPF-SB</b> 205 205-13 205-14 205-15 205-16	25 1 3/16 7/8 1 5/16 1	95 3 3/4	76 2 53/64	18 23/32	9 23/64	4 0,157	60 2 23/64	M8 5/16	31 1,2204	7,5 0,2953	SA205 SA205-13 SA205-14 SA205-15 SA205-16	0,42	27 1,0630	7,5 0,2953	SB205 SB205-13 SB205-14 SB205-15 SB205-16	0,38	PF205	13 300	7 460
<b>BPF-SA</b> <b>BPF-SB</b> 206 206-17 206-18 206-19 206-20	30 1 1/16 1 1/8 1 3/16 1 1/4	113 4 7/16	90,5 3 9/16	18 23/32	11 7/16	5,2 0,205	71 2 51/64	M10 3/8	35,7 1,4055	9 0,3543	SA206 SA206-17 SA206-18 SA206-19 SA206-20	0,65	30 1,1811	8 0,3150	SB206 SB206-17 SB206-18 SB206-19 SB206-20	0,62	PF206	18 500	10 800
<b>BPF-SA</b> <b>BPF-SB</b> 207 207-20 207-21 207-22 207-23	35 1 1/4 1 5/16 1 3/8 1 7/16	122 4 13/16	100 3 15/16	20 25/32	11 7/16	5,2 0,205	81 3 3/16	M10 3/8	38,9 1,5315	9,5 0,3740	SA207 SA207-20 SA207-21 SA207-22 SA207-23	0,9	32 1,2598	8,5 0,3346	SB207 SB207-20 SB207-21 SB207-22 SB207-23	0,82	PF207	24 500	14 600
<b>BPF-SA</b> <b>BPF-SB</b> 208 208-24 208-25	40 1 1/2 1 9/16	148 5 13/16	119 4 11/16	21 13/16	13,5 17/32	6,8 0,268	91 3 37/64	M12 1/2	43,7 1,7205	11 0,4331	SA208 SA208-24 SA208-25	1,15	34 1,3386	9 0,3543	SB208 SB208-24 SB208-25	1,1	PF208	27 700	17 000

Disponibile in acciaio inox Supporto: AISI 304 - Cuscinetto: AISI 440C  
Available stainless steel Housing: AISI 304 - Bearing: AISI 440C

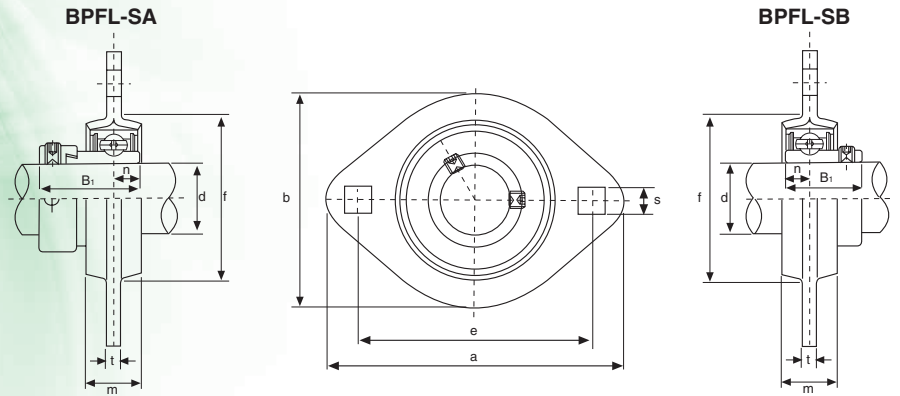

Tipo Type	Dimensioni mm/pollici Dimensions mm/inch								Bull. fiss. Bolt Size mm/inch	BPFL-SA		Cuscinetto Bearing	Peso Weight (kg)	BPFL-SB		Cuscinetto Bearing	Peso Weight (kg)	Supporto Housing	Coefficienti di carico (N) Load ratings (N)	
	d	a	e	b	m	s	t	f (min)		B <sub>1</sub>	n			B <sub>1</sub>	n				Dinamico C <sub>D</sub>	Statico C <sub>S</sub>
BPFL-SA BPFL-SB 201 201-8	12 3/4	81 3 3/16	63,5 2 1/2	59 2 21/64	14 9/16	7,1 1 59/64	4 0,157	49 1 59/64	M6 1/4	28,6 1,1260	6,5 0,2559	SA201 SA201-8	0,22	22 0,8661	6 0,2362	SB201 SB201-8	0,19	PFL203	9 200	4 480
BPFL-SA BPFL-SB 202 202-9 202-10	15 9/16 5/8	81 3 3/16	63,5 2 1/2	59 2 21/64	14 9/16	7,1 1 59/64	4 0,157	49 1 59/64	M6 1/4	28,6 1,1260	6,5 0,2559	SA202 SA202-9 SA202-10	0,22	22 0,8661	6 0,2362	SB202 SB202-9 SB202-10	0,19	PFL203	9 200	4 480
BPFL-SA BPFL-SB 203 203-11	17 1 1/16	81 3 3/16	63,5 2 1/2	59 2 21/64	14 9/16	7,1 1 59/64	4 0,157	49 1 59/64	M6 1/4	28,6 1,1260	6,5 0,2559	SA203 SA203-11	0,22	22 0,8661	6 0,2362	SB203 SB203-11	0,19	PFL203	9 200	4 480
BPFL-SA BPFL-SB 204 204-12	20 3/4	90 3 5/8	71,5 2 13/16	67 2 41/64	16 5/8	9 23/64	4 0,157	56 2 13/64	M8 5/16	31 1,2204	7,5 0,2953	SA204 SA204-12	0,24	25 0,9843	7 0,2756	SB204 SB204-12	0,24	PFL204	12 200	6 300
BPFL-SA BPFL-SB 205 205-13 205-14 205-15 205-16	25 1 3/16 7/8 1 5/16 1	95 3 3/4	76 2 53/64	71 2 51/64	18 23/32	9 23/64	4 0,157	60 2 23/64	M8 5/16	31 1,2204	7,5 0,2953	SA205 SA205-13 SA205-14 SA205-15 SA205-16	0,32	27 1,0630	7,5 0,2953	SB205 SB205-13 SB205-14 SB205-15 SB205-16	0,28	PFL205	13 300	7 460
BPFL-SA BPFL-SB 206 206-17 206-18 206-19 206-20	30 1 1/16 1 1/8 1 3/16 1 1/4	113 4 7/16	90,5 3 9/16	84 3 5/16	18 23/32	11 7/16	5,2 0,205	71 2 51/64	M10 3/8	35,7 1,4055	9 0,3543	SA206 SA206-17 SA206-18 SA206-19 SA206-20	0,41	30 1,1811	8 0,3150	SB206 SB206-17 SB206-18 SB206-19 SB206-20	0,38	PFL206	18 500	10 800
BPFL-SA BPFL-SB 207 207-20 207-21 207-22 207-23	35 1 1/4 1 5/16 1 3/8 1 7/16	122 4 13/16	100 3 15/16	94 3 45/64	20 25/32	11 7/16	5,2 0,205	81 3 3/16	M10 3/8	38,9 1,5315	9,5 0,3740	SA207 SA207-20 SA207-21 SA207-22 SA207-23	0,52	32 1,2598	8,5 0,3346	SB207 SB207-20 SB207-21 SB207-22 SB207-23	0,50	PFL207	24 500	14 600
BPFL-SA BPFL-SB 208 208-24 208-25	40 1 1/2 1 3/8	148 5 13/16	119 4 11/16	100 3 15/16	21 13/16	13,5 1 7/32	6,8 0,268	91 3 37/64	M12 1/2	43,7 1,7205	11 0,4331	SA208 SA208-24 SA208-25	0,83	34 1,3386	9 0,3543	SB208 SB208-24 SB208-25	0,80	PFL208	27 700	17 000

Disponibile in acciaio inox Supporto: AISI 304 - Cuscinetto: AISI 440C  
Available stainless steel Housing: AISI 304 - Bearing: AISI 440C



# SUPPORTI A FLANGIA TRIANGOLARE IN LAMIERA STAMPATA PRESSED STEEL TRIANGULAR FLANGE UNITS

# KDF®

## BPFT2-SA - BPFT2-SB Serie leggera Light Series

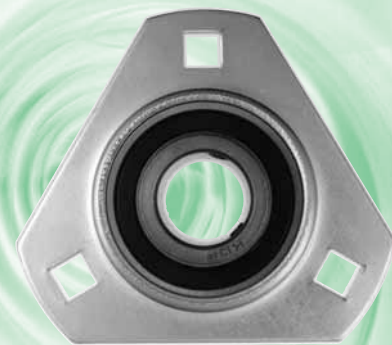
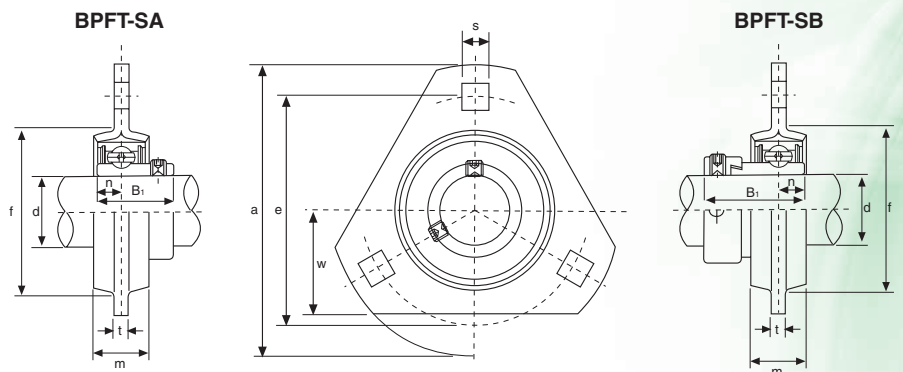

Tipo Type	Dimensioni mm/pollici Dimensions mm/inch									Bull. fiss. Bolt Size mm/inch	BPFL-SA		Cuscinetto Bearing	Peso Weight (kg)	BPFL-SB		Cuscinetto Bearing	Peso Weight (kg)	Supporto Housing	Coefficienti di carico (N) Load ratings (N)	
	d	a	e	w	m	s	t	f (min)	B <sub>1</sub>		n	B <sub>1</sub>			n	Dinamico C Dynamic C				Statico C <sub>0</sub> Static C <sub>0</sub>	
BPFT-SA BPFT-SB 201 201-8	12 3/4	81 3 3/16	63,5 2 1/2	28,5 1 1/8	14 9/16	7,1 9/32	4 0,157	49 1 59/64	M6 1/4	28,6 1,1260	6,5 0,2559	SA201 SA201-8	0,26	22 0,8661	6 0,2362	SB201 SB201-8	0,23	PFT203	9 200	4 480	
BPFT-SA BPFT-SB 202 202-9 202-10	15 9/16 5/8	81 3 3/16	63,5 2 1/2	28,5 1 1/8	14 9/16	7,1 9/32	4 0,157	49 1 59/64	M6 1/4	28,6 1,1260	6,5 0,2559	SA202 SA202-9 SA202-10	0,26	22 0,8661	6 0,2362	SB202 SB202-9 SB202-10	0,23	PFT203	9 200	4 480	
BPFT-SA BPFT-SB 203 203-11	17 1 1/16	81 3 3/16	63,5 2 1/2	28,5 1 1/8	14 9/16	7,1 9/32	4 0,157	49 1 59/64	M6 1/4	28,6 1,1260	6,5 0,2559	SA203 SA203-11	0,26	22 0,8661	6 0,2362	SB203 SB203-11	0,23	PFT203	9 200	4 480	
BPFT-SA BPFT-SB 204 204-12	20 3/4	90 3 5/8	71,5 2 13/16	33 1 19/64	16 5/8	9 23/64	4 0,157	56 2 13/64	M8 5/16	31 1,2204	7,5 0,2953	SA204 SA204-12	0,28	25 0,9843	7 0,2756	SB204 SB204-12	0,28	PFT204	12 200	6 300	
BPFT-SA BPFT-SB 205 205-13 205-14 205-15 205-16	25 1 3/16 7/8 1 5/16 1	95 3 3/4	76 2 53/64	35 1 3/8	18 23/32	9 23/64	4 0,157	60 2 23/64	M8 5/16	31 1,2204	7,5 0,2953	SA205 SA205-13 SA205-14 SA205-15 SA205-16	0,36	27 1,0630	7,5 0,2953	SB205 SB205-13 SB205-14 SB205-15 SB205-16	0,36	PFT205	13 300	7 460	
BPFT-SA BPFT-SB 206 206-17 206-18 206-19 206-20	30 1 1/16 1 1/8 1 3/16 1 1/4	113 4 7/16	90,5 3 9/16	40 1 37/64	18 23/32	11 7/16	5,2 0,205	71 2 51/64	M10 3/8	35,7 1,4055	9 0,3543	SA206 SA206-17 SA206-18 SA206-19 SA206-20	0,58	30 1,1811	8 0,3150	SB206 SB206-17 SB206-18 SB206-19 SB206-20	0,55	PFT206	18 500	10 800	
BPFT-SA BPFT-SB 207 207-20 207-21 207-22 207-23	35 1 1/4 1 5/16 1 3/8 1 7/16	122 4 13/16	100 3 15/16	44,5 1 3/4	20 25/32	11 7/16	5,2 0,205	81 3 3/16	M10 3/8	38,9 1,5315	9,5 0,3740	SA207 SA207-20 SA207-21 SA207-22 SA207-23	0,82	32 1,2598	8,5 0,3346	SB207 SB207-20 SB207-21 SB207-22 SB207-23	0,74	PFT207	24 500	14 600	

Disponibile in acciaio inox Supporto: AISI 304 - Cuscinetto: AISI 440C  
Available stainless steel Housing: AISI 304 - Bearing: AISI 440C



### UC2 Serie normale Normal Series



Suffisso UNF: Misure in pollici dei grani di bloccaggio  
UNF suffix: inch sizes set screws

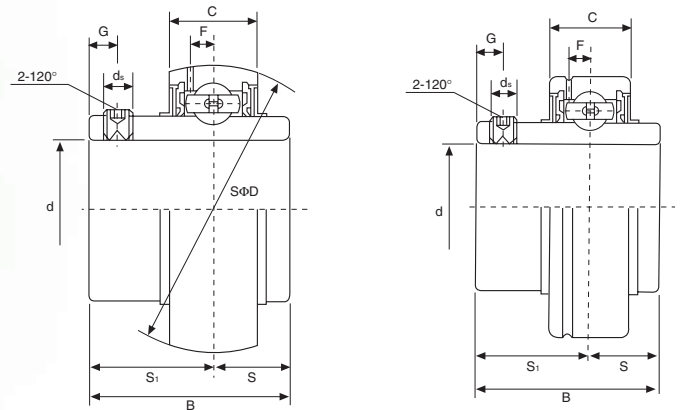

Tipo Type	Dimensioni mm/pollici Dimensions mm/inch									Coefficienti di carico (N) Load ratings (N)		Peso Weight (kg)
	d	D	B	C	S	S <sub>1</sub>	G	d <sub>s</sub>	F	Dinamico C Dynamic C	Statico C <sub>0</sub> Static C <sub>0</sub>	
UC201 UC201-8	12 3/4	47 1,8504	31 1,2205	17 0,6693	12,7 0,500	18,3 0,720	4,8 0,189	M6x1 1/4-28UNF	3,7 0,146	12 200	6 350	0,20 0,19
UC202 UC202-9 UC202-10	15 5/8	47 1,8504	31 1,2205	17 0,6693	12,7 0,500	18,3 0,720	4,8 0,189	M6x1 1/4-28UNF	3,7 0,146	12 200	6 350	0,19 0,19 0,19
UC203 UC203-11	17 1 1/16	47 1,8504	31 1,2205	17 0,6693	12,7 0,500	18,3 0,720	4,8 0,189	M6x1 1/4-28UNF	3,7 0,146	12 200	6 350	0,18 0,17
UC204 UC204-12	20 3/4	47 1,8504	31 1,2205	17 0,6693	12,7 0,500	18,3 0,720	4,8 0,189	M6x1 1/4-28UNF	3,7 0,146	12 200	6 350	0,16 0,16
UC205 UC205-13 UC205-14 UC205-15 UC205-16	25 1 3/16 7/8 15/16 1	52 2,0472	34,1 1,3425	17 0,6693	14,3 0,563	19,8 0,780	5 0,197	M6x1 1/4-28UNF	3,9 0,154	13 300	7 500	0,20 0,24 0,23 0,21 0,20
UC206 UC206-17 UC206-18 UC206-19 UC206-20	30 1 1/16 1 1/8 1 3/8 1 1/4	62 2,4409	38,1 1,5000	19 0,7480	15,9 0,626	22,2 0,874	5 0,197	M6x1 1/4-28UNF	5,0 0,197	18 600	10 800	0,32 0,33 0,34 0,32 0,31
UC207 UC207-20 UC207-21 UC207-22 UC207-23	35 1 1/4 1 9/16 1 3/8 1 7/8	72 2,8346	42,9 1,6890	20 0,7874	17,5 0,689	25,4 1,000	7 0,276	M8x1 5/16-24UNF	5,7 0,224	24 500	14 600	0,48 0,54 0,51 0,48 0,45
UC208 UC208-24 UC208-25	40 1 1/2 1 9/16	80 3,1496	49,2 1,9370	21 0,8268	19 0,748	30,2 1,189	8 0,315	M8x1 5/16-24UNF	6,2 0,244	27 700	17 000	0,64 0,68 0,65
UC209 UC209-26 UC209-27 UC209-28	45 1 9/16 1 11/16 1 3/4	85 3,3465	49,2 1,9370	22 0,8661	19 0,748	30,2 1,189	8 0,315	M8x1 5/16-24UNF	6,4 0,252	31 000	19 500	0,68 0,78 0,74 0,70
UC210 UC210-29 UC210-30 UC210-31 UC210-32	50 1 13/16 1 7/8 1 15/16 2	90 3,5433	51,6 2,0315	24 0,9449	19 0,748	32,6 1,283	10 0,394	M10x1 3/8-24UNF	6,5 0,256	33 500	22 500	0,80 0,92 0,87 0,82 0,78
UC211 UC211-32 UC211-33 UC211-34 UC211-35	55 2 2 1/16 2 1/8 2 3/16	100 3,9370	55,6 2,1890	25 0,9843	22,2 0,874	33,4 1,315	10 0,394	M10x1 3/8-24UNF	7,0 0,276	41 500	28 000	1,11 1,26 1,20 1,15 1,09
UC212 UC212-36 UC212-37 UC212-38 UC212-39	60 2 1/4 2 5/16 2 3/8 2 7/16	110 4,3307	65,1 2,5630	27 1,0630	25,4 1,000	39,7 1,563	10 0,394	M10x1 3/8-24UNF	7,6 0,299	50 000	34 500	1,54 1,67 1,59 1,52 1,45
UC213 UC213-40 UC213-41	65 2 1/2 2 9/16	120 4,3307	65,1 2,5630	28 1,1024	25,4 1,000	39,7 1,563	10 0,394	M10x1 3/8-24UNF	8,5 0,335	54 700	38 000	1,85 1,94 1,85
UC214 UC214-42 UC214-43 UC214-44	70 2 9/16 2 11/16 2 9/4	125 4,9213	74,6 2,9370	29 1,1417	30,2 1,189	44,4 1,748	12 0,472	M12x1,5 7/16-20UNF	8,9 0,350	59 000	42 000	2,05 2,26 2,16 2,06
UC215 UC215-45 UC215-46 UC215-47 UC215-48	75 2 13/16 2 7/8 2 15/16 3	130 5,1181	77,8 3,0630	30 1,1811	33,3 1,311	44,5 1,752	12 0,472	M12x1,5 7/16-20UNF	9,2 0,362	63 000	47 000	2,21 2,46 2,35 2,24 2,12
UC216 UC216-49 UC216-50 UC216-51	80 3 1/16 3 1/8 3 9/16	140 5,5118	82,6 3,2520	32 1,2598	33,3 1,311	49,3 1,9409	12 0,472	M12x1,5 7/16-20UNF	9,5 0,374	69 000	51 000	2,80 2,98 2,85 2,72
UC217 UC217-52 UC217-53 UC217-55	85 3 1/4 3 9/16 3 7/16	150 5,9055	85,7 3,3740	34 1,3386	34,1 1,343	51,6 2,031	12 0,472	M12x1,5 7/16-20UNF	10,2 0,402	80 000	61 000	3,46 3,68 3,54 3,25
UC218 UC218-56	90 3 1/2	160 6,2992	96 3,7795	36 1,4173	39,7 1,5630	56,3 2,217	12 0,472	M12x1,5 7/16-20UNF	11,2 0,441	91 200	68 200	4,36 4,47

Disponibile in acciaio inox: AISI 440C  
Available stainless steel: AISI 440C



HC2 Serie normale Normal Series

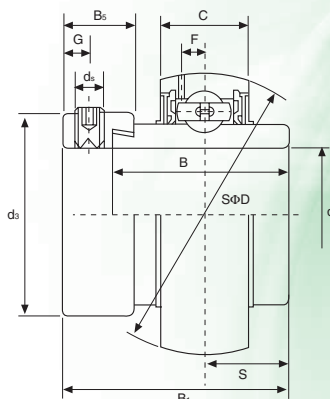

Suffisso UNF: Misure in pollici dei grani di bloccaggio  
UNF suffix: inch sizes set screws

Tipo Type	Dimensioni mm/pollici Dimensions mm/inch											Coefficienti di carico (N) Load ratings (N)		Peso Weight (kg)
	d	D	B <sub>1</sub>	B	C	S	d <sub>s</sub>	G	B <sub>s</sub>	d <sub>s</sub>	F	Dinamico C Dynamic C	Statico C <sub>0</sub> Static C <sub>0</sub>	
HC204 HC204-12	20 3/4	47 1,8504	43,7 1,720	34,2 1,3465	17 0,6693	17,1 0,673	M6x1 1/4-28UNF	4,8 0,189	13,5 0,531	33,3 1,311	3,7 0,146	12 200	6 350	0,23 0,23
HC205 HC205-13 HC205-14 HC205-15 HC205-16	25 1 1/16 7/8 1 1/16 1	52 2,0472	44,4 1,748	34,9 1,3740	17 0,6693	17,5 0,689	M6x1 1/4-28UNF	4,8 0,189	13,5 0,531	38,1 1,500	3,9 0,154	13 300	7 500	0,27 0,32 0,31 0,29 0,27
HC206 HC206-17 HC206-18 HC206-19 HC206-20	30 1 1/16 1 1/8 1 1/16 1 1/4	62 2,4409	48,4 1,906	36,5 1,4370	19 0,7480	18,3 0,720	M8x1 5/16-24UNF	6 0,236	15,9 0,626	44,5 1,752	5,0 0,197	18 600	10 800	0,45 0,50 0,47 0,45 0,42
HC207 HC207-20 HC207-21 HC207-22 HC207-23	35 1 1/4 1 5/16 1 3/8 1 7/16	72 2,8346	51,1 2,012	37,6 1,4803	20 0,7874	18,8 0,740	M8x1 5/16-24UNF	6,8 0,268	17,5 0,689	55,6 2,189	5,7 0,224	24 500	14 600	0,60 0,67 0,63 0,60 0,57
HC208 HC208-24 HC208-25	40 1 1/2 1 5/8	80 3,1496	56,3 2,217	42,8 1,6850	21 0,8268	21,4 0,843	M8x1 5/16-24UNF	6,8 0,268	18,3 0,720	60,3 2,374	6,2 0,244	27 700	17 000	0,79 0,84 0,80
HC209 HC209-26 HC209-27 HC209-28	45 1 3/8 1 11/16 1 3/4	85 3,3465	56,3 2,217	42,8 1,6850	22 0,8661	21,4 0,843	M8x1 5/16-24UNF	6,8 0,268	18,3 0,720	63,5 2,5000	6,4 0,252	31 000	19 500	0,85 0,96 0,91 0,87
HC210 HC210-29 HC210-30 HC210-31 HC210-32	50 1 13/16 1 7/8 1 15/16 2	90 3,5433	62,7 2,469	49,2 1,9370	24 0,9449	24,6 0,969	M8x1 5/16-24UNF	6,8 0,268	18,3 0,720	69,9 2,752	6,5 0,256	33 500	22 500	0,99 1,14 1,08 1,02 0,96
HC211 HC211-32 HC211-33 HC211-34 HC211-35	55 2 2 1/16 2 1/8 2 3/16	100 3,9370	71,4 2,811	55,5 2,1850	25 0,9843	27,8 1,094	M10x1 3/8-24UNF	8 0,315	20,7 0,815	76,2 3,000	7,0 0,276	41 500	28 000	1,32 1,52 1,44 1,37 1,29
HC212 HC212-36 HC212-37 HC212-38 HC212-39	60 2 1/4 2 3/16 2 3/8 2 7/16	110 4,3307	77,8 3,063	61,9 2,4370	27 1,0630	31 1,220	M10x1 3/8-24UNF	8 0,315	22,3 0,878	84,2 3,315	7,6 0,299	50 000	34 500	1,88 2,04 1,95 1,90 1,77
HC213 HC213-40 HC213-41	65 2 1/2 2 5/8	120 4,7244	85,7 3,374	68,6 2,7008	28 1,1024	34,1 1,343	M10x1 3/8-24UNF	8,5 0,335	23,5 0,925	86 3,386	8,5 0,335	54 700	38 000	2,41 2,51 2,40
HC214 HC214-42 HC214-43 HC214-44	70 2 3/8 2 11/16 2 3/4	125 4,9213	85,7 3,374	68,6 2,7008	29 1,1417	34,1 1,343	M10x1 3/8-24UNF	8,5 0,335	23,5 0,925	90 3,543	8,9 0,350	59 000	42 000	2,55 2,79 2,68 2,56
HC215 HC215-45 HC215-46 HC215-47 HC215-48	75 2 13/16 2 7/8 2 15/16 3	130 5,1181	92,1 3,626	75 2,9528	30 1,1811	37,3 1,469	M10x1 3/8-24UNF	8,5 0,335	23,5 0,925	102 4,016	9,2 0,362	63 000	47 000	2,84 3,14 3,01 2,88 2,74

Disponibile in acciaio inox: AISI 440C  
Available stainless steel: AISI 440C

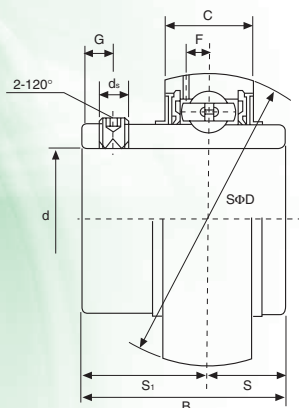

Suffisso UNF: Misure in pollici dei grani di bloccaggio  
UNF suffix: inch sizes set screws

Tipo Type	Dimensioni mm/pollici Dimensions mm/inch									Coefficienti di carico (N) Load ratings (N)		Peso Weight (kg)			
	d	D	B	C	S	S <sub>1</sub>	G	d <sub>s</sub>	F	Dinamico C Dynamic C	Statico C <sub>0</sub> Static C <sub>0</sub>				
UCX05 UCX05-13 UCX05-14 UCX05-15 UCX05-16	25 1 3/16 7/8 15/16 1	62	38,1	19	15,9	22,2	5	M6x1	5,0	18 600	10 800	0,39			
UCX06 UCX06-17 UCX06-18 UCX06-19	30 1 1/16 1 1/8 1 1/16	2,4409	1,5000	0,7480	0,626	0,874	0,197	1/4-28UNF	0,197						
UCX07 UCX07-21 UCX07-22 UCX07-23	35 1 5/16 1 3/8 1 7/16	3,1496	1,9370	0,8268	0,748	1,189	0,315	5/16-24UNF	0,244				27 700	17 000	0,82
UCX08 UCX08-24 UCX08-25	40 1 1/2 1 5/16	3,3465	1,9370	0,8661	0,748	1,189	0,315	5/16-24UNF	0,252						
UCX09 UCX09-26 UCX09-27 UCX09-28	45 1 3/8 1 11/16 1 3/4	3,5433	2,0315	0,9449	0,748	1,283	0,394	3/8-24UNF	0,256						
UCX10 UCX10-30 UCX10-31	50 1 7/8 1 15/16	3,9370	2,1890	0,9843	0,874	1,315	0,394	3/8-24UNF	0,276	41 400	27 800	1,35			
UCX11 UCX11-33 UCX11-34 UCX11-35	55 2 1/16 2 1/8 2 3/16	4,3307	2,5630	1,0630	1,000	1,563	0,394	3/8-24UNF	0,299				49 900	34 200	1,90
UCX12 UCX12-38 UCX12-39	60 2 3/8 2 7/16	4,3307	2,5630	1,1024	1,000	1,563	0,394	3/8-24UNF	0,335	54 700	38 000	2,27			
UCX13 UCX13-40 UCX13-41	65 2 1/2 2 5/16	4,9213	2,9370	1,1417	1,189	1,748	0,472	7/16-20UNF	0,350				58 900	41 800	2,45
UCX14 UCX14-42 UCX14-43 UCX14-44	70 2 3/8 2 11/16 2 3/4	5,1181	3,0630	1,1811	1,311	1,752	0,472	7/16-20UNF	0,362	63 000	47 100	2,47			
UCX15 UCX15-45 UCX15-46 UCX15-47 UCX15-48	75 2 13/16 2 7/8 2 15/16 3	5,5118	3,2520	1,2598	1,311	1,9409	0,472	7/16-20UNF	0,374				68 900	50 500	3,11
UCX16 UCX16-49 UCX16-50 UCX16-51	80 3 1/16 3 1/8 3 3/16	5,9055	3,3740	1,3386	1,343	2,031	0,472	7/16-20UNF	0,402	79 400	61 000	3,79			
UCX17 UCX17-53 UCX17-55	85 3 3/16 3 7/16	6,2992	3,7795	1,4173	1,5630	2,217	0,472	1/2-20UNF	0,441				91 500	68 000	4,82
UCX18 UCX18-56 UCX18-57	90 3 7/16 3 1/2	6,6929	4,0945	1,5354	1,689	2,406	0,511	9/16-18UNF	0,413	104 000	80 000	5,51			
UCX20 UCX20-58 UCX20-59 UCX20-60 UCX20-61	100 3 13/16 3 7/8 3 15/16 4	7,4803	4,6260	1,7323	1,937	2,689	0,630	5/8-18UNF	0,445				127 000	100 000	8,95

Disponibile in acciaio inox: AISI 440C  
Available stainless steel: AISI 440C





**CUSCINETTI A SFERE SIGILLATI CON GRANI DI BLOCCAGGIO**  
**SEALED BALL BEARINGS WITH SET SCREWS**



**UC3 Serie pesante Heavy Series**

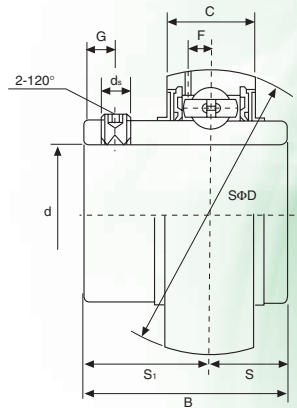

Suffisso UNF: Misure in pollici dei grani di bloccaggio  
 UNF Suffix: inch sizes set screws

Tipo Type	Dimensioni mm/pollici Dimensions mm/inch									Coefficienti di carico (N) Load ratings (N)		Peso Weight (kg)
	d	D	B	C	S	S <sub>1</sub>	G	d <sub>s</sub>	F	Dinamico C Dynamic C	Statico C <sub>0</sub> Static C <sub>0</sub>	
UC305 UC305-13 UC305-14 UC305-15 UC305-16	25 1 9/16 7/8 1 9/16 1	62 2,4409	38 1,4961	20 0,7874	15 0,591	23 0,906	6 0,236	M6x1 1/4-28UNF	5,4 0,213	20 200	11 930	0,35 0,40 0,38 0,36 0,35
UC306 UC306-17 UC306-18 UC306-19	30 1 1/16 1 1/8 1 1/16	72 2,8346	43 1,6929	23 0,9055	17 0,669	26 1,024	6 0,236	M6x1 1/4-28UNF	5,7 0,225	25 400	14 300	0,56 0,61 0,58 0,56
UC307 UC307-20 UC307-21 UC307-22 UC307-23	35 1 1/4 1 5/16 1 3/8 1 7/16	80 3,1496	48 1,8898	25 0,9843	19 0,748	29 1,142	8 0,315	M8x1 5/16-24UNF	6,2 0,224	31 900	18 200	0,71 0,77 0,74 0,71 0,68
UC308 UC308-24 UC308-25	40 1 1/2 1 5/16	90 3,5433	52 2,0472	27 1,0630	19 0,748	33 1,299	10 0,394	M10x1 3/8-24UNF	7,0 0,276	38 500	23 000	0,96 1,01 0,97
UC309 UC309-26 UC309-27 UC309-28	45 1 5/8 1 11/16 1 3/4	100 3,9370	57 2,2441	30 1,1811	22 0,866	35 1,378	10 0,394	M10x1 3/8-24UNF	7,8 0,307	50 500	30 500	1,28 1,39 1,35 1,30
UC310 UC310-29 UC310-30 UC310-31	50 1 13/16 1 7/8 1 15/16	110 4,3307	61 2,4016	32 1,2598	22 0,866	39 1,535	12 0,472	M12x1,5 7/16-20UNF	8,5 0,335	59 000	36 600	1,65 1,97 1,74 1,68
UC311 UC311-32 UC311-33 UC311-34 UC311-35	55 2 2 1/16 2 1/8 2 3/16	120 4,7244	66 2,5984	34 1,3386	25 0,984	41 1,614	12 0,472	M12x1,5 7/16-20UNF	9,2 0,362	68 000	43 000	2,07 2,25 2,18 2,12 2,04
UC312 UC312-36 UC312-37 UC312-38 UC312-39	60 2 1/4 2 5/16 2 3/8 2 7/16	130 5,1181	71 2,7953	36 1,4173	26 1,0236	45 1,772	12 0,472	M12x1,5 7/16-20UNF	9,8 0,386	78 000	49 500	2,60 2,75 2,67 2,58 2,50
UC313 UC313-40 UC313-41	65 2 1/2 2 5/16	140 5,5118	75 2,9528	38 1,4961	30 1,181	45 1,772	12 0,472	M12x1,5 7/16-20UNF	10,5 0,413	88 000	57 000	3,25 3,34 3,24
UC314 UC314-42 UC314-43 UC314-44	70 2 5/8 2 11/16 2 3/4	150 5,9055	78 3,0708	40 1,5748	33 1,299	45 1,772	12 0,472	M12x1,5 7/16-20UNF	11,1 0,437	99 000	64 600	3,89 4,11 4,00 3,90
UC315 UC315-45 UC315-46 UC315-47 UC315-48	75 2 13/16 2 7/8 2 15/16 3	160 6,2992	82 3,2283	42 1,6535	32 1,260	50 1,969	14 0,551	M14x1,5 9/16-18UNF	11,8 0,465	108 000	73 500	4,72 4,99 4,85 4,76 4,63
UC316 UC316-49 UC316-50 UC316-51	80 3 1/16 3 1/8 3 3/16	170 6,6929	86 3,3858	44 1,7323	34 1,339	52 2,047	14 0,551	M14x1,5 9/16-18UNF	12,5 0,492	117 000	83 000	5,55 5,72 5,58 5,49
UC317 UC317-52 UC317-53 UC317-55	85 3 3/4 3 5/8 3 7/16	180 7,0866	96 3,7795	46 1,8110	40 1,575	56 2,205	16 0,630	M16x1,5 5/8-18UNF	13,1 0,516	127 000	93 000	6,67 6,89 6,76 6,44
UC318 UC318-55 UC318-56	90 3 7/16 3 1/2	190 7,4803	96 3,7795	48 1,8898	40 1,575	56 2,205	16 0,630	M16x1,5 5/8-18UNF	13,8 0,543	136 000	102 000	7,56 7,85 7,67
UC319 UC319-58 UC319-59 UC319-60	95 3 5/8 3 11/16 3 3/4	200 7,8740	103 4,0551	50 1,9685	41 1,614	62 2,441	16 0,630	M16x1,5 5/8-18UNF	14,7 0,579	145 000	113 000	8,70 9,03 8,85 8,66
UC320 UC320-61 UC320-62 UC320-63 UC320-64	100 3 15/16 3 7/8 3 15/16 4	215 8,4646	108 4,2520	55 2,1654	42 1,654	66 2,598	18 0,709	M18x1,5 5/8-18UNF	13,5 0,531	165 000	134 000	10,8 24,7 24,2 23,8 23,4

Disponibile in acciaio inox: AISI 440C  
 Available stainless steel: AISI 440C



### UK2 Serie normale Normal Series

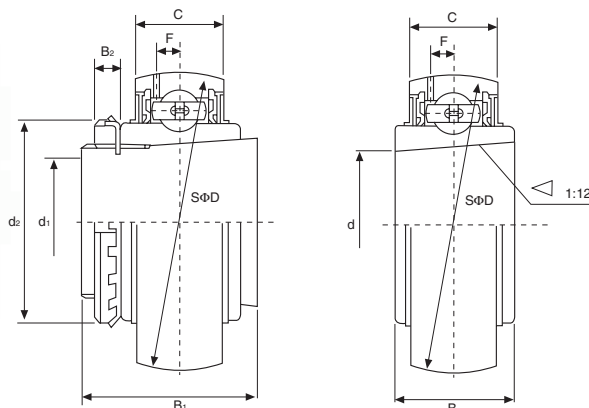
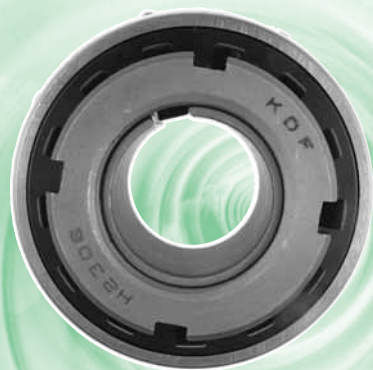

Tipo Type	Dimensioni mm/pollici Dimensions mm/inch									Coefficients di carico (N) Load ratings (N)		Peso Weight (kg)
	d	D	B	C	d <sub>1</sub>	B <sub>1</sub>	B <sub>2</sub>	d <sub>2</sub>	F	Dinamico C Dynamic C	Statico C <sub>0</sub> Static C <sub>0</sub>	
UK205+H2305 UK205+HE2305	25 0,9843	52 2,0472	23 0,9055	17 0,6693	20 ¾	35 1,378	8 0,315	38 1,496	3,9 0,154	13 500	7 500	0,25
UK206+H2306 UK206+HS2306 UK206+HE2306	30 1,1811	62 2,4409	26 1,0236	19 0,7480	25 1	38 1,496	8 0,315	45 1,772	5,0 0,197	18 600	10 800	0,36
UK207+H2307 UK207+HS2307	35 1,3780	72 2,8346	29 1,1417	20 0,7874	30 1½	43 1,693	9 0,354	52 2,047	5,7 0,224	24 500	14 600	0,57
UK208+H2308 UK208+HE2308 UK208+HS2308	40 1,5748	80 3,1496	31 1,2205	21 0,8268	35 1¼ 1¾	46 1,811	10 0,394	58 2,283	6,2 0,244	27 700	16 900	0,74
UK209+H2309 UK209+HA2309 UK209+HE2309 UK209+HS2309	45 1,7717	85 3,3465	31 1,2205	22 0,8661	40 1⅞ 1½ 1⅝	50 1,969	11 0,433	65 2,559	6,4 0,252	31 000	19 400	0,83
UK210+H2310 UK210+HS2310 UK210+HA2310 UK210+HE2310	50 1,9685	90 3,5433	32 1,2598	24 0,9449	45 1¾ 1⅞ 1¾	55 2,165	12 0,472	70 2,756	6,5 0,256	33 300	22 000	0,97
UK211+H2311 UK211+HS2311 UK211+HA2311 UK211+HE2311	55 2,1654	100 3,9370	35 1,3780	25 0,9843	50 1⅞ 1⅞ 2	59 2,323	12 0,472	75 2,953	7,0 0,276	41 400	27 800	1,26
UK212+H2312 UK212+HS2312	60 2,3622	110 4,3307	38 1,4961	27 1,0630	55 2⅞	62 2,441	13 0,512	80 3,150	7,6 0,299	49 900	34 200	1,59
UK213+H2313 UK213+HA2313 UK213+HE2313 UK213+HS2313	65 2,5591	120 4,7244	40 1,5748	28 1,1024	60 2¾ 2¼ 2¾	65 2,559	14 0,551	85 3,346	8,5 0,335	54 700	38 000	1,76
UK215+H2315 UK215+HA2315 UK215+HE2315	75 2,9528	130 5,1181	44 1,7323	30 1,1811	65 2⅞ 2½	73 2,874	15 0,591	98 3,858	9,2 0,362	63 000	47 000	2,32
UK216+H2316 UK216+HA2316 UK216+HE2316	80 3,1496	140 5,5118	45 1,7717	32 1,2598	70 2⅞ 2¾	78 3,071	17 0,669	105 4,134	9,5 0,374	68 900	51 000	3,06
UK217+H2317 UK217+HA2317 UK217+HE2317	85 3,3465	150 5,9055	46 1,8110	34 1,3386	75 2⅞ 3	82 3,228	18 0,709	110 4,331	10,2 0,402	80 000	61 000	3,88
UK218+H2318 UK218+HA2318	90 3,5433	160 6,2992	47 1,8504	36 1,4173	80 3⅞	86 3,386	18 0,709	120 4,724	11,2 0,441	91 200	68 000	4,74

Disponibile in acciaio inox: AISI 440C  
Available stainless steel: AISI 440C

Bussole HA; HE; HS con filettatura in pollici  
Inch dimension adapter sleeves HA; HE; HS



**CUSCINETTI A SFERE SIGILLATI CON BUSSOLA MONTATA**  
**SEALED BALL BEARINGS WITH ADAPTER SLEEVE MOUNTED**

**KDF®**

**UKX Serie media Medium Series**

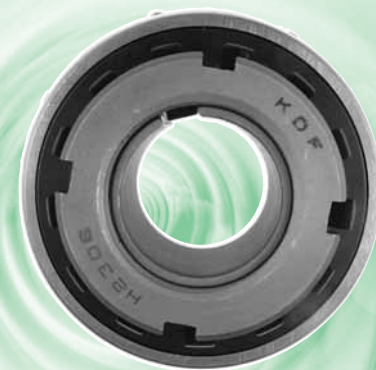
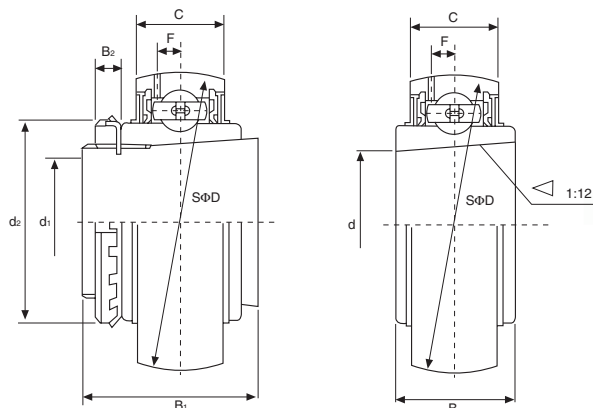

Tipo Type	Dimensioni mm/pollici Dimensions mm/inch									Coefficienti di carico (N) Load ratings (N)		Peso Weight (kg)
	d	D	B	C	d <sub>1</sub>	B <sub>1</sub>	B <sub>2</sub>	d <sub>2</sub>	F	Dinamico C Dynamic C	Statico C <sub>0</sub> Static C <sub>0</sub>	
UKX05+H2305 UKX05+HE2305 UKX05+HA2305	25 0,9843	62 2,4409	26 1,0236	19 0,7480	20 ¾ 13/16	35 1,3780	8 0,3150	38 1,4961	5,1 0,2008	18 600	10 800	0,38
UKX06+H2306 UKX06+HS2306 UKX06+HA2306 UKX06+HE2306	30 1,1811	72 2,8346	27 1,0630	20 0,7874	25 7/8 19/16 1	38 1,4961	8 0,3150	45 1,7717	5,8 0,2283	24 500	14 500	0,54
UKX07+H2307 UKX07+HS2307 UKX07+HA2307	35 1,3780	80 3,1496	29 1,1417	21 0,8268	30 1 1/8 1 3/16	43 1,6929	9 0,3543	52 2,0472	6,2 0,2441	27 700	17 000	0,75
UKX08+H2308 UKX08+HE2308 UKX08+HA2308 UKX08+HS2308	40 1,5748	85 3,3465	30 1,1811	22 0,8661	35 1 1/4 1 5/16 1 3/8	46 1,8110	10 0,3937	58 2,2835	6,5 0,2559	30 900	19 500	0,81
UKX09+H2309 UKX09+HA2309 UKX09+HE2309 UKX09+HS2309	45 1,7717	90 3,5433	31 1,2205	23 0,9055	40 1 7/16 1 1/2 1 5/8	50 1,9685	11 0,4331	65 2,5591	6,5 0,2559	33 300	22 000	0,97
UKX10+H2310 UKX10+HA2310 UKX10+HE2310	50 1,9685	100 3,9370	33 1,2992	24 0,9449	45 1 11/16 1 3/4	55 2,1654	12 0,4724	70 2,7559	7,3 0,2874	41 500	27 800	1,22
UKX11+H2311 UKX11+HS2311 UKX11+HA2311 UKX11+HE2311	55 2,1654	110 4,3307	36 1,4173	26 1,0236	50 1 7/8 1 15/16 2	59 2,3238	12 0,4724	75 2,9528	7,7 0,3031	49 900	34 200	1,66
UKX12+H2312 UKX12+HA2312 UKX12+HS2312	60 2,3622	120 4,7244	38 1,4961	27 1,0630	55 2 1/16 2 1/8	62 2,4409	13 0,5118	80 3,1496	8,3 0,3268	54 700	38 000	1,89
UKX13+H2313 UKX13+HA2313 UKX13+HE2313 UKX13+HS2313	65 2,5591	125 4,9213	40 1,5748	29 1,1417	60 2 3/16 2 1/4 2 3/8	65 2,5591	14 0,5512	85 3,3465	8,7 0,3425	58 900	42 000	2,09
UKX15+H2315 UKX15+HE2315	75 2,9528	140 5,5118	44 1,7323	32 1,2598	65 2 1/2	73 2,8740	15 0,5906	98 3,8583	9,6 0,3780	69 000	50 500	3,21
UKX16+H2316 UKX16+HE2316	80 3,1496	150 5,9055	46 1,8110	34 1,3386	70 2 3/4	78 3,0709	17 0,6693	105 4,1339	10,5 0,4134	80 000	61 000	3,86
UKX17+H2317 UKX17+HE2317	85 3,3465	160 6,2992	49 1,9291	36 1,4173	75 3	82 3,2283	18 0,7087	110 4,3307	11,1 0,4370	91 200	68 000	4,76
UKX18+H2318 UKX18+HS2318	90 3,5433	170 6,6929	52 2,0472	38 1,4961	80 3 1/8	86 3,3858	18 0,7087	120 4,7244	11,9 0,4685	104 000	78 000	5,11

Bussole HA; HE; HS con filettatura in pollici  
 Inch dimension adapter sleeves HA; HE; HS



### UK3 Serie pesante Heavy Series

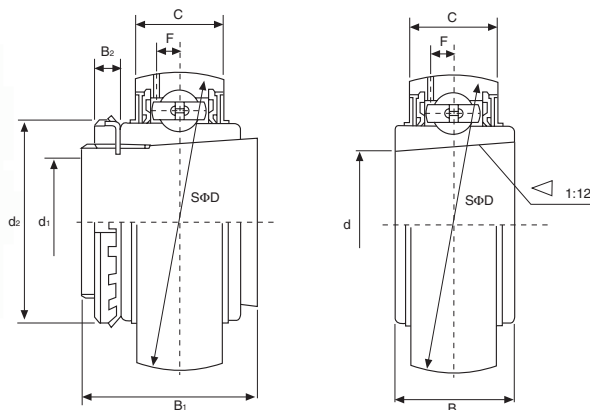
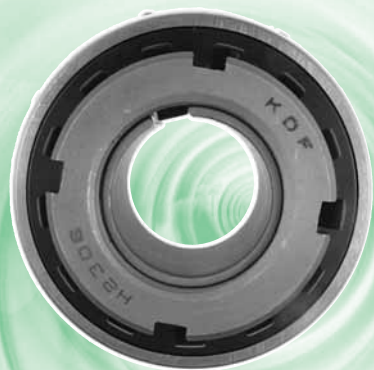

Tipo Type	Dimensioni mm/pollici Dimensions mm/inch									Coefficients di carico (N) Load ratings (N)		Peso Weight (kg)
	d	D	B	C	d <sub>1</sub>	B <sub>1</sub>	B <sub>2</sub>	d <sub>2</sub>	F	Dinamico C Dynamic C	Statico C <sub>0</sub> Static C <sub>0</sub>	
UK305+H2305 UK305+HE2305	25 0,9843	62 2,4409	26 1,0236	20 0,7874	20 ¾	35 1,378	8 0,315	38 1,496	5,0 0,197	20 500	10 500	0,48
UK306+H2306 UK306+HS2306 UK306+HE2306	30 1,1811	72 2,8346	29 1,1417	23 0,9055	25 7/8 1	38 1,496	8 0,315	45 1,772	5,9 0,232	25 400	14 300	0,59
UK307+H2307 UK307+HS2307	35 1,3780	80 3,1496	33 1,2992	25 0,9843	30 1 1/8	43 1,693	9 0,354	52 2,047	6,8 0,268	32 000	18 200	0,76
UK308+H2308 UK308+HE2308 UK308+HS2308	40 1,5748	90 3,5433	34 1,3386	27 1,0630	35 1 1/4 1 3/8	46 1,811	10 0,394	58 2,283	7,4 0,291	38 500	23 000	1,07
UK309+H2309 UK309+HA2309 UK309+HE2309 UK309+HS2309	45 1,7717	100 3,9370	37 1,4567	29 1,1417	40 1 7/16 1 1/2 1 5/8	50 1,969	11 0,433	65 2,559	7,4 0,291	50 500	30 500	1,31
UK310+H2310 UK310+HS2310 UK310+HA2310 UK310+HE2310	50 1,9685	110 4,3307	41 1,6142	32 1,2598	45 1 3/8 1 11/16 1 3/4	55 2,165	12 0,472	70 2,756	8,1 0,319	60 000	36 600	1,70
UK311+H2311 UK311+HS2311 UK311+HA2311 UK311+HE2311	55 2,1654	120 4,7244	44 1,7323	34 1,3386	50 1 7/8 1 15/16 2	59 2,323	12 0,472	75 2,953	8,5 0,335	68 000	43 000	2,06
UK312+H2312 UK312+HS2312	60 2,3622	130 5,1181	47 1,8504	36 1,4173	55 2 1/8	62 2,441	13 0,512	80 3,150	9 0,354	80 000	49 500	2,58
UK313+H2313 UK313+HA2313 UK313+HE2313 UK313+HS2313	65 2,5591	140 5,5118	49 1,9291	39 1,5354	60 2 3/16 2 1/4 2 3/8	65 2,559	14 0,551	85 3,346	10,1 0,398	88 000	57 000	3,07
UK315+H2315 UK315+HA2315 UK315+HE2315	75 2,9528	160 6,2992	55 2,1654	43 1,6929	65 2 7/16 2 1/2	73 2,874	15 0,591	98 3,858	11 0,433	108 000	73 200	4,82
UK316+H2316 UK316+HA2316 UK316+HE2316	80 3,1496	170 6,6929	58 2,2835	45 1,7717	70 2 11/16 2 3/4	78 3,071	17 0,669	105 4,134	11,4 0,449	117 000	82 200	5,63
UK317+H2317 UK317+HA2317 UK317+HE2317	85 3,3465	180 7,0866	60 2,3622	47 1,8504	75 2 15/16 3	82 3,228	18 0,709	110 4,331	12,0 0,472	126 500	92 200	6,47
UK318+H2318 UK318+HA2318	90 3,5433	190 7,4803	64 2,5197	49 1,9291	80 3 1/16	86 3,386	18 0,709	120 4,724	12,3 0,484	136 000	102 000	7,52

Bussole HA; HE; HS con filettatura in pollici  
Inch dimension adapter sleeves HA; HE; HS



# CUSCINETTI A SFERE SIGILLATI CON ANELLO DI FISSAGGIO SEALED BALL BEARINGS WITH LOCATING SNAP RING



## SER2 Serie normale Normal Series

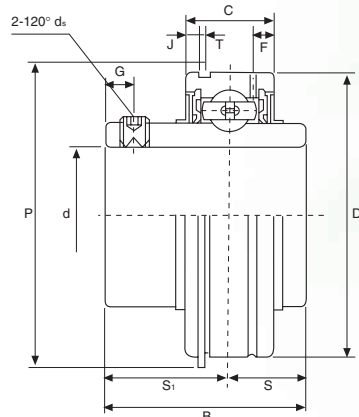

Suffisso UNF: Misure in pollici dei grani di bloccaggio  
UNF suffix: inch sizes set screws

Tipo Type	Dimensioni mm/pollici Dimensions mm/inch												Coefficients di carico (N) Load ratings (N)		Peso Weight (kg)
	d	D	B	C	S	S <sub>1</sub>	T	F	J	P	G	ds	Dinamico C Dynamic C	Statico C <sub>0</sub> Static C <sub>0</sub>	
SER204 SER204-12	20 ¾	47 1,8504	31 1,2205	15,9 0,6260	10,3 0,406	20,7 0,815	1,12 0,044	3,8 0,150	2,46 0,097	52,7 2,075	4,8 0,189	M6x1 ¼-28UNF	9 880	6 200	0,21
SER205 SER205-13 SER205-14 SER205-15 SER205-16	25 1⅜ 7/8 1⅝ 1	52 2,0472	34,9 1,3740	19 0,7480	13,1 0,516	21,8 0,858	1,12 0,044	5,2 0,205	2,46 0,097	57,9 2,280	5 0,197	M6x1 ¼-28UNF	10 780	6 980	0,27
SER206 SER206-17 SER206-18 SER206-19 SER206-20	30 1⅞ 1⅞ 1⅝ 1¼	62 2,4409	38,1 1,5000	22,2 0,8740	15,9 0,626	22,2 0,874	1,7 0,067	5,6 0,220	3,28 0,129	67,7 2,665	5 0,197	M6x1 ¼-28UNF	14 970	10 040	0,39
SER207 SER207-20 SER207-21 SER207-22 SER207-23	35 1¼ 1⅝ 1⅝ 1⅞	72 2,8346	42,9 1,6890	23,8 0,9370	17,5 0,689	25,4 1,000	1,7 0,067	5,6 0,220	3,28 0,129	78,6 3,094	6,7 0,264	M8x1 ⅝-24UNF	19 750	13 670	0,63
SER208 SER208-24 SER208-25	40 1½ 1⅞	80 3,1496	49,2 1,9370	27,8 1,0945	19 0,748	30,2 1,189	1,7 0,067	6,4 0,252	3,28 0,129	86,6 3,409	8 0,315	M8x1 ⅝-24UNF	22 710	15 940	0,81
SER209 SER209-26 SER209-27 SER209-28	45 1⅝ 1⅞ 1¾	85 3,3465	49,2 1,9370	27,8 1,0945	19 0,748	30,2 1,189	1,7 0,067	6,4 0,252	3,28 0,129	91,6 3,606	8 0,315	M8x1 ⅝-24UNF	24 360	17 710	0,90
SER210 SER210-29 SER210-30 SER210-31 SER210-32	50 1⅞ 1⅞ 1⅝ 2	90 3,5433	51,6 2,0315	28,6 1,1260	19 0,748	32,6 1,283	2,46 0,097	7,5 0,295	3,28 0,129	96,5 3,799	10 0,394	M10x1 ¾-24UNF	26 980	19 840	0,98
SER211 SER211-32 SER211-33 SER211-34 SER211-35	55 2 2⅞ 2⅞ 2⅞	100 3,9370	55,6 2,1890	30,2 1,1890	22,2 0,874	33,4 1,315	2,46 0,097	7,5 0,295	3,28 0,129	106,5 4,193	10 0,394	M10x1 ¾-24UNF	33 370	25 110	1,40
SER212 SER212-36 SER212-37 SER212-38 SER212-39	60 2¼ 2⅞ 2⅞ 2⅞	110 4,3307	65,1 2,5630	31,8 1,2520	25,4 1,000	39,7 1,563	2,46 0,097	7,5 0,295	3,28 0,129	116,6 4,591	10 0,394	M10x1 ¾-24UNF	36 740	27 970	1,89



### SA2 Serie leggera Light Series

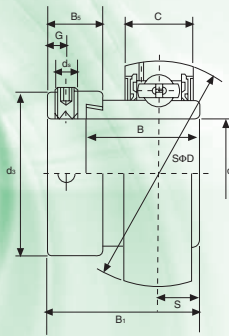
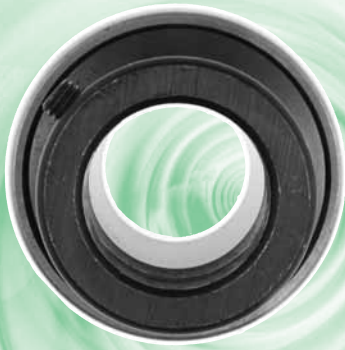

**SA 2**  
anello esterno sferico  
outer spherical ring

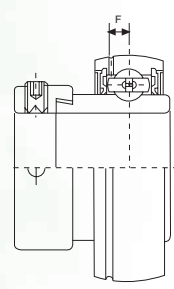

**SA 2S**  
anello esterno sferico, con sede per seigeer  
outer spherical ring, with groove for snap ring

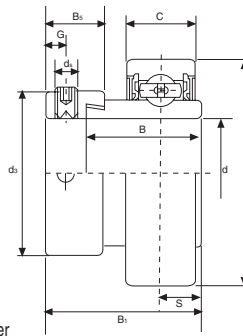

**SA 2C**  
anello esterno cilindrico  
outer cylindrical ring

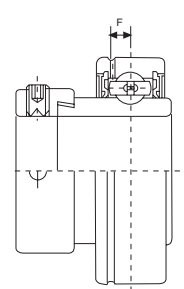

**SA 2CS**  
anello esterno cilindrico,  
con sede per seigeer  
outer cylindrical ring,  
with groove for snap ring

Suffisso UNF: Misure in pollici dei grani di bloccaggio  
UNF suffix: inch sizes set screws

Tipo Type	Dimensioni mm/pollici Dimensions mm/inch											Coefficients di carico (N) Load ratings (N)		Peso Weight (kg)
	d	D	B <sub>1</sub>	B	C	S	d <sub>s</sub>	G	B <sub>s</sub>	d <sub>3</sub>	F	Dinamico C Dynamic C	Statico C <sub>0</sub> Static C <sub>0</sub>	
<b>SA201</b> <b>SA201-8</b>	12 3/4	40 1,5748	28,6 1,126	19,1 0,7520	12 0,4724	6,5 0,256	M6x1 1/4-28UNF	4,8 0,189	13,5 0,531	28,6 1,126	3,7 0,146	9 200	4 480	0,12 0,12
<b>SA202</b> <b>SA202-9</b> <b>SA202-10</b>	15 9/16 5/8	40 1,5748	28,6 1,126	19,1 0,7520	12 0,4724	6,5 0,256	M6x1 1/4-28UNF	4,8 0,189	13,5 0,531	28,6 1,126	3,7 0,146	9 200	4 480	0,10 0,10 0,10
<b>SA203</b> <b>SA203-11</b>	17 1 1/16	40 1,5748	28,6 1,126	19,1 0,7520	12 0,4724	6,5 0,256	M6x1 1/4-28UNF	4,8 0,189	13,5 0,531	28,6 1,126	3,7 0,146	9 200	4 480	0,09 0,09
<b>SA204</b> <b>SA204-12</b>	20 3/4	47 1,8504	31 1,220	21,5 0,8465	14 0,5512	7,5 0,295	M6x1 1/4-28UNF	4,8 0,189	13,5 0,531	33,3 1,311	3,7 0,146	12 200	6 300	0,16 0,16
<b>SA205</b> <b>SA205-13</b> <b>SA205-14</b> <b>SA205-15</b> <b>SA205-16</b>	25 1 9/16 7/8 1 1/16 1	52 2,0472	31 1,220	21,5 0,8465	15 0,5906	7,5 0,295	M6x1 1/4-28UNF	4,8 0,189	13,5 0,531	38,1 1,500	3,9 0,154	13 300	7 460	0,20 0,22 0,21 0,21 0,20
<b>SA206</b> <b>SA206-17</b> <b>SA206-18</b> <b>SA206-19</b> <b>SA206-20</b>	30 1 1/16 1 1/8 1 3/16 1 1/4	62 2,4409	35,7 1,406	23,8 0,9370	16 0,6299	9 0,354	M8x1 5/16-28UNF	6 0,236	15,9 0,626	44,5 1,752	5,0 0,197	18 500	10 800	0,30 0,32 0,31 0,30 0,29
<b>SA207</b> <b>SA207-20</b> <b>SA207-21</b> <b>SA207-22</b> <b>SA207-23</b>	35 1 1/4 1 5/16 1 3/8 1 7/16	72 2,8346	38,9 1,531	25,4 1,000	17 0,6693	9,5 0,374	M8x1 5/16-24UNF	6,8 0,268	17,5 0,689	55,6 2,189	5,7 0,224	24 500	14 600	0,42 0,46 0,43 0,42 0,41
<b>SA208</b> <b>SA208-24</b> <b>SA208-25</b>	40 1 1/2 1 5/16	80 3,1496	43,7 1,721	30,2 1,1890	18 0,7087	11 0,433	M8x1 5/16-24UNF	6,8 0,268	18,3 0,720	60,3 2,374	6,2 0,244	27 700	17 000	0,60 0,58 0,60
<b>SA209</b> <b>SA209-26</b> <b>SA209-27</b> <b>SA209-28</b>	45 1 3/8 1 11/16 1 3/4	85 3,3465	43,7 1,721	30,2 1,1890	19 0,7480	11 0,433	M8x1 5/16-24UNF	6,8 0,268	18,3 0,720	63,5 2,500	6,4 0,252	31 100	24 450	0,76
<b>SA210</b> <b>SA210-29</b> <b>SA210-30</b> <b>SA210-31</b> <b>SA210-32</b>	50 1 13/16 1 7/8 1 15/16 2	90 3,5433	43,7 1,721	30,2 1,1890	20 0,7874	11 0,433	M8x1 5/16-24UNF	6,8 0,268	18,3 0,720	69,9 2,752	6,5 0,256	35 300	28 160	0,91
<b>SA211</b> <b>SA211-32</b> <b>SA211-33</b> <b>SA211-34</b> <b>SA211-35</b>	55 2 2 1/16 2 1/8 2 3/16	100 3,9370	48,4 1,906	32,5 1,2795	21 0,8268	12 0,472	M8x1 5/16-24UNF	8 0,315	20,7 0,815	76,2 3,000	7,0 0,276	38 100	30 000	1,26
<b>SA212</b> <b>SA212-36</b> <b>SA212-37</b> <b>SA212-38</b> <b>SA212-39</b>	60 2 1/4 2 5/16 2 3/8 2 7/16	110 4,3307	53,1 2,091	37,2 1,4646	22 0,8661	13,5 0,532	M10x1 3/8-24UNF	8 0,315	22,3 0,878	84,2 3,315	7,6 0,299	41 500	32 730	1,70

Disponibile in acciaio inox: AISI 440C  
Available stainless steel: AISI 440C



# CUSCINETTI A SFERE SIGILLATI CON GRANI DI BLOCCAGGIO SEALED BALL BEARINGS WITH SET SCREWS

# KDF®

## SB-RB2 Serie leggera Light Series

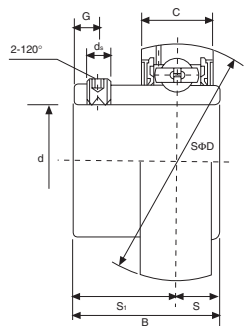

**SB 2**  
anello esterno sferico  
outer spherical ring

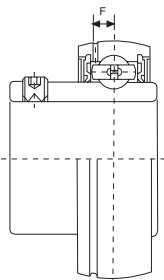

**SB 2S**  
anello esterno sferico,  
con sede per seigeer  
outer spherical ring,  
with groove for snap ring

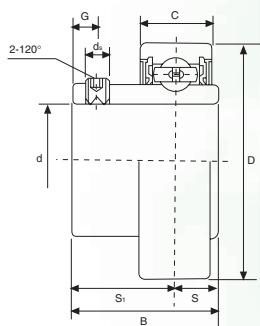

**RB 2C**  
anello esterno cilindrico  
outer cylindrical ring

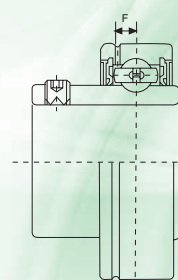

**RB 2CS**  
anello esterno cilindrico,  
con sede per seigeer  
outer cylindrical ring,  
with groove for snap ring



Suffisso UNF: Misure in pollici dei grani di bloccaggio  
UNF suffix: inch sizes set screws

Tipo Type	Dimensioni mm/pollici Dimensions mm/inch									Coefficienti di carico (N) Load ratings (N)		Peso Weight (kg)
	d	D	B	C	S	S <sub>1</sub>	d <sub>s</sub>	G	F	Dinamico C Dynamic C	Statico C <sub>0</sub> Static C <sub>0</sub>	
SB-RB201 SB-RB201-8	12 3/4	40 1,5748	22 0,8661	12 0,4724	6 0,236	16 0,630	M5x0,8 10-32UNF	4,5 0,177	3,7 0,146	9 200	4 480	0,10 0,10
SB-RB202 SB-RB202-9 SB-RB202-10	15 9/16 5/8	40 1,5748	22 0,8661	12 0,4724	6 0,236	16 0,630	M5x0,8 10-32UNF	4,5 0,177	3,7 0,146	9 200	4 480	0,10 0,10 0,10
SB-RB203 SB-RB203-11	17 1 1/16	40 1,5748	22 0,8661	12 0,4724	6 0,236	16 0,630	M5x0,8 10-32UNF	4,5 0,177	3,7 0,146	9 200	4 480	0,09 0,09
SB-RB204 SB-RB204-12	20 3/4	47 1,8504	25 0,9843	14 0,5512	7 0,276	18 0,709	M6x1 1/4-28UNF	4,5 0,177	3,7 0,146	12 200	6 300	0,13 0,14
SB-RB205 SB-RB205-13 SB-RB205-14 SB-RB205-15 SB-RB205-16	25 1 3/16 7/8 1 1/16 1	52 2,0472	27 1,0630	15 0,5906	7,5 0,295	19,5 0,768	M6x1 1/4-28UNF	5,5 0,217	3,9 0,154	13 300	7 460	0,16 0,19 0,18 0,17 0,16
SB-RB206 SB-RB206-17 SB-RB206-18 SB-RB206-19 SB-RB206-20	30 1 1/16 1 1/8 1 3/16 1 1/4	62 2,4409	30 1,1811	16 0,6299	8 0,315	22 0,866	M6x1 1/4-28UNF	6 0,236	5,0 0,197	18 500	10 800	0,25 0,28 0,26 0,25 0,24
SB-RB207 SB-RB207-20 SB-RB207-21 SB-RB207-22 SB-RB207-23	35 1 1/4 1 5/16 1 3/8 1 7/16	72 2,8346	32 1,2598	17 0,6693	8,5 0,335	23,5 0,925	M8x1 5/16-24UNF	6,5 0,256	5,7 0,224	24 500	14 600	0,38 0,43 0,41 0,38 0,37
SB-RB208 SB-RB208-24 SB-RB208-25	40 1 1/2 1 9/16	80 3,1496	34 1,3386	18 0,7087	9 0,354	25 0,984	M8x1 5/16-24UNF	7 0,276	6,2 0,244	27 700	17 000	0,60 0,58 0,60
SB-RB209 SB-RB209-26 SB-RB209-27 SB-RB209-28	45 1 5/8 1 11/16 1 3/4	85 3,3465	41,2 1,6220	19 0,7480	10,2 0,402	31 1,220	M8x1 5/16-24UNF	8,2 0,323	6,4 0,252	31 100	24 450	0,8
SB-RB210 SB-RB210-29 SB-RB210-30 SB-RB210-31 SB-RB210-32	50 1 13/16 1 7/8 1 15/16 2	90 3,5433	43,5 1,7126	20 0,7874	10,9 0,429	32,6 1,283	M10x1 3/8-24UNF	9,2 0,362	6,5 0,256	35 300	28 160	0,8
SB-RB211 SB-RB211-32 SB-RB211-33 SB-RB211-34 SB-RB211-35	55 2 2 1/16 2 1/8 2 3/16	100 3,9370	45,3 1,7835	21 0,8268	11,8 0,465	33,5 1,319	M10x1 3/8-24UNF	9,8 0,386	7,0 0,276	38 100	30 000	1,1
SB-RB212 SB-RB212-36 SB-RB212-37 SB-RB212-38 SB-RB212-39	60 2 1/4 2 5/16 2 3/8 2 7/16	110 4,3307	53,7 2,1142	22 0,8661	14,9 0,587	38,8 1,528	M10x1 3/8-24UNF	9,8 0,386	7,6 0,299	41 500	32 730	1,3

Disponibile in acciaio inox: AISI 440C  
Available stainless steel: AISI 440C

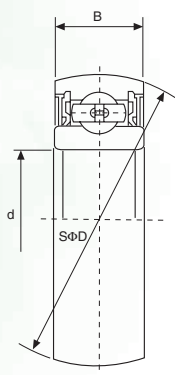

Tipo Type	Dimensioni mm/pollici Dimensions mm/inch			Coefficients di carico (N) Load ratings (N)		Peso Weight (kg)
	d	D	B	Dinamico C Dynamic C	Statico C <sub>0</sub> Static C <sub>0</sub>	
SC200 SC200	10 0,3937	30 1,1811	9 0,3543	3 750	2 150	0,030
SC201 SC201	12 0,4724	32 1,2598	10 0,3937	4 500	2 500	0,035
SC202 SC202	15 0,5906	35 1,3780	11 0,4331	5 650	3 300	0,040
SC203 SC203	17 0,6693	40 1,5748	12 0,4724	7 000	4 480	0,06
SC204 SC204	20 0,7874	47 1,8504	14 0,5512	9 880	6 200	0,10
SC205 SC205	25 0,9843	52 2,0472	15 0,5906	10 780	6 980	0,13
SC206 SC206	30 1,1811	62 2,4409	16 0,6299	14 970	10 040	0,20
SC207 SC207	35 1,3780	72 2,8346	17 0,6693	19 750	13 670	0,29
SC208 SC208	40 1,5748	80 3,1496	18 0,7087	22 710	15 940	0,37
SC209 SC209	45 1,7717	85 3,3465	19 0,7480	24 360	17 710	0,46
SC210 SC210	50 1,9685	90 3,5433	20 0,7874	26 980	19 840	0,57
SC211 SC211	55 2,1654	100 3,9370	21 0,8268	28 500	21 850	0,62
SC212 SC212	60 2,3622	110 4,3307	22 0,8661	31 700	24 500	0,80

Equivalente serie 62.. bombato ISB® - Equivalent 62.. spherical ISB®

## CUSCINETTI CON GRANI BEARINGS WITH SET SCREWS

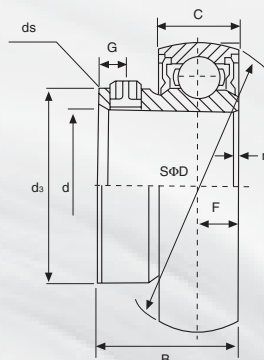
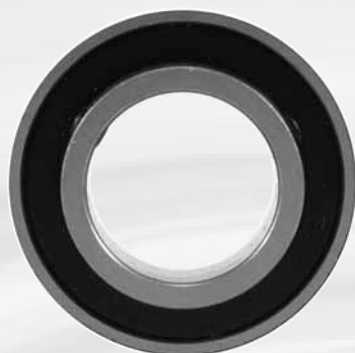

Tipo Type	Dimensioni mm/pollici Dimensions mm/inch									Coefficients di carico (N) Load ratings (N)		Peso Weight (kg)
	d	D	B	C	d <sub>s</sub>	F	G	r	d <sub>s</sub>	Dinamico C Dynamic C	Statico C <sub>0</sub> Static C <sub>0</sub>	
U000 U000	10 0,3937	26 1,024	14 0,5512	8 0,3150	14,75 0,5807	4 1,1575	3 0,1181	0,5 0,0197	M3	470	200	0,023
U001 U001	12 0,4724	28 1,1024	14,5 0,5709	8 0,3150	17,35 0,6831	4 1,1575	3 0,1181	0,5 0,0197	M3	520	245	0,027
U002 U002	15 0,5906	32 1,2598	16,5 0,6496	9 0,3543	20,02 0,7882	4,5 0,1772	3,5 0,1378	0,5 0,0197	M4	570	290	0,045
U003 U003	17 0,6693	35 1,3780	17,5 0,6890	10 0,3937	23,10 0,9094	5 0,1969	3,5 0,1378	0,5 0,0197	M4	610	335	0,050
U004 U004	20 0,7874	42 1,6535	21 0,8268	12 0,4724	27,00 1,0630	6 0,2362	4 1,1575	1 0,0394	M5	955	515	0,086
U005 U005	25 0,9843	47 1,8504	22,5 0,8858	12 0,4724	31,70 1,2480	6 0,2362	4,5 0,1772	1 0,0394	M5	1030	595	0,100
U006 U006	30 1,1811	55 2,1654	24,5 0,9646	13 0,5118	38,00 1,4961	6,5 0,2559	5 0,1969	1,5 0,0591	M5	1350	845	0,145

Disponibile su richiesta in acciaio inox: AISI 440C - Available under request stainless steel: AISI 440C





# BUSSOLE DI TRAZIONE ADAPTER SLEEVES

# KDF®

## Serie H 23 Series H 23

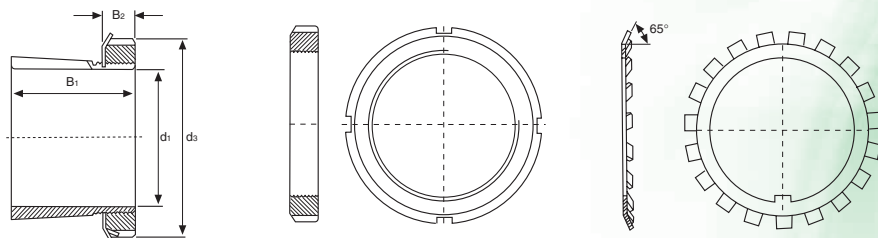

Tipo Type	Dimensioni mm/pollici Dimensions mm/inch				Bussola Sleeve A...	Ghiera di bloccaggio Lock nut KM	Rosetta Washer MB	Cuscinetto Bearing			Peso Weight (kg)
	d <sub>1</sub>	B <sub>1</sub>	B <sub>2</sub>	d <sub>3</sub>				Serie normale Normal duty	Serie media Medium duty	Serie pesante Heavy duty	
H 2305 HE 2305	20 ¾	35 1,3780	8 0,3150	38 1,4961	A 2305X AE 2305X	KM 05	MB 05	UK 205	UK X05	UK 305	0,087
H 2306 HS 2306 HA 2306 HE 2306	25 7/8 15/16 1	38 1,4961	8 0,3150	45 1,7717	A 2306X AS 2306X AA 2306X AE 2306X	KM 06	MB 06	UK 206	UK X06	UK 306	0,126
H 2307 HS 2307 HA 2307	30 1 1/8 1 3/16	43 1,6929	9 0,3543	52 2,0472	A 2307X AS 2307X AA 2307X	KM 07	MB 07	UK 207	UK X07	UK 307	0,165
H 2308 HE 2308 HS 2308	35 1 1/4 1 3/8	46 1,8110	10 0,3937	58 2,2835	A 2308X AE 2308X AS 2308X	KM 08	MB 08	UK 208	UK X08	UK 308	0,224
H 2309 HA 2309 HE 2309 HS 2309	40 1 7/16 1 1/2 1 5/8	50 1,9685	11 0,4331	65 2,5591	A 2309X AA 2309X AE 2309X AS 2309X	KM 09	MB 09	UK 209	UK X09	UK 309	0,280
H 2310 HA 2310 HE 2310	45 1 11/16 1 3/4	55 2,1654	12 0,4724	70 2,7559	A 2310X AA 2310X AE 2310X	KM 10	MB 10	UK 210	UK X10	UK 310	0,362
H 2311 HS 2311 HA 2311 HE 2311	50 1 7/8 1 9/16 2	59 2,3228	12 0,4724	75 2,9528	A 2311X AS 2311X AA 2311X AE 2311X	KM 11	MB 11	UK 211	UK X11	UK 311	0,420
H 2312 HS 2312	55 2 1/8	62 2,4409	13 0,5118	80 3,1496	A 2312X AS 2312X	KM 12	MB 12	UK 212	UK X12	UK 312	0,480
H 2313 HA 2313 HE 2313 HS 2313	60 2 3/16 2 1/4 2 3/8	65 2,5591	14 0,5512	85 3,3465	A 2313X AA 2313X AE 2313X AS 2313X	KM 13	MB 13	UK 213	UK X13	UK 313	0,556
H 2315 HE 2315 HS 2315	65 2 1/2 2 5/8	73 2,8740	15 0,5906	98 3,8583	A 2315X AE 2315X AS 2315X	KM 15	MB 15	UK 215	UK X15	UK 315	1,05
H 2316 HE 2316	70 2 3/4	78 3,0709	17 0,6693	105 4,1339	A 2316X AE 2316X	KM 16	MB 16	UK 216	UK X16	UK 316	1,28
H 2317 HS 2317 HA 2317 HE 2317	75 2 7/8 2 9/16 3	82 3,2283	18 0,7087	110 4,3307	A 2317X AS 2317X AA 2317X AE 2317X	KM 17	MB 17	UK 217	UK X17	UK 317	1,45
H 2318 HA 2318	80 3 1/16	86 3,3858	18 0,7087	120 4,7244	A 2318X AA 2318X	KM 18	MB 18	UK 218	UK X18	UK 318	1,70
H 2319 HE 2319	85 3 1/4	90 3,5433	19 0,7480	125 4,9213	A 2319X AE 2319X	KM 19	MB 19	-	-	UK 319	1,94
H 2320 HE 2320	90 3 1/2	97 3,8189	20 0,7874	130 5,1181	A 2320X AE 2320X	KM 20	MB 20	-	UK X20	UK 320	2,15
H 2322 HE 2322	100 4	105 4,1339	21 0,8268	145 5,7087	A 2322X AE 2322X	KM 22	MB 22	-	-	UK 322	2,74
H 2324 HA 2324	110 4 3/16	112 4,4094	22 0,8661	155 6,1024	A 2324X AA 2324X	KM 24	MB 24	-	-	UK 324	3,20
H 2326 HE 2326	115 4 1/2	121 4,7638	23 0,9055	165 6,4961	A 2326X AE 2326X	KM 26	MB 26	-	-	UK 326	4,60
H 2328 HA 2328 HE 2328	125 4 9/16 5 1/8	131 5,1575	24 0,9449	180 7,0866	A 2328X AA 2328X AE 2328X	KM 28	MB 28	-	-	UK 328	5,52



SNG 500 - SNG 600



SNU 500 - SNU 600  
SNA 500 - SNA 600



SN 500 - SN 600  
SN 200 - SN 300



SD 3100



SD 3000

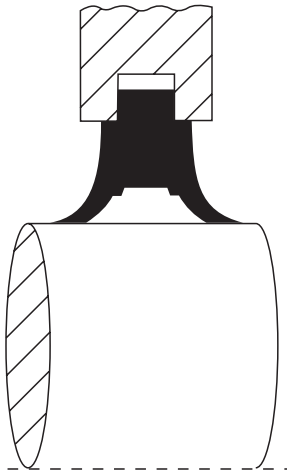

Tenuta in poliuretano "TSNG" per: SNG-SNU  
*"TSNG" polyurethan seal for: SNG-SNU*

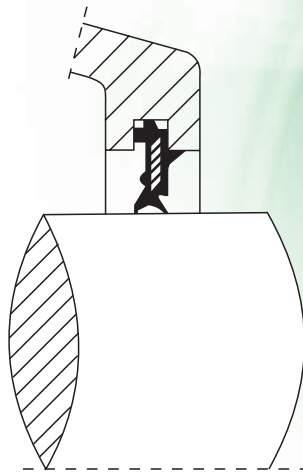

Tenuta in gomma "TSNU" per: SNG-SNU  
*"TSNU" rubber seal for: SNG-SNU*

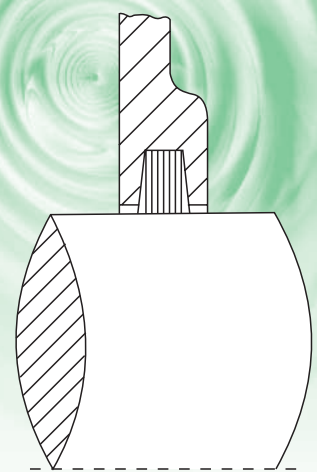

Tenuta in feltro "TSNC" per: SNG-SNU  
*"TSNC" felt seal for: SNG-SNU*

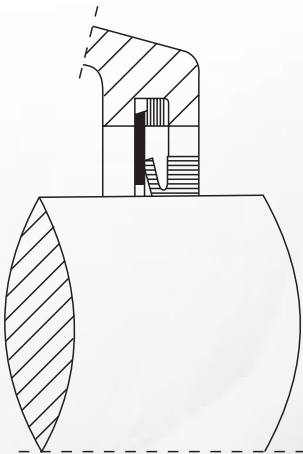

Tenuta v-ring "TSNA" per: SNG-SNU  
*"TSNA" v-ring seal for: SNG-SNU*

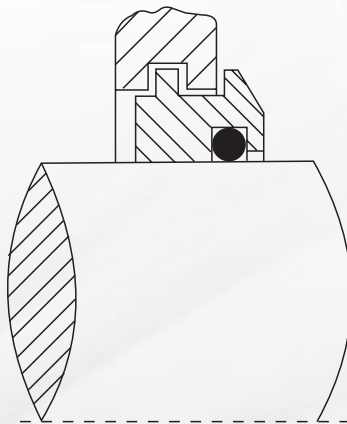

Tenuta a labirinto "TSNS" per: SNG-SNU  
*"TSNS" labyrinth seal for: SNG-SNU*

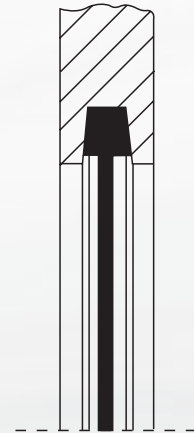

Coperchio di chiusura "A" per: SNG-SNU-SN  
*"A" end cover for: SNG-SNU-SN*

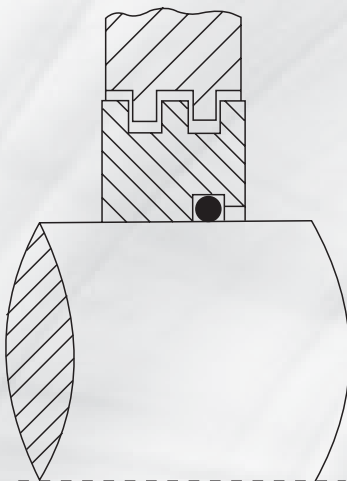

Tenuta a labirinto "TS" per: SN-SD  
*"TS" labyrinth seal for: SN-SD*

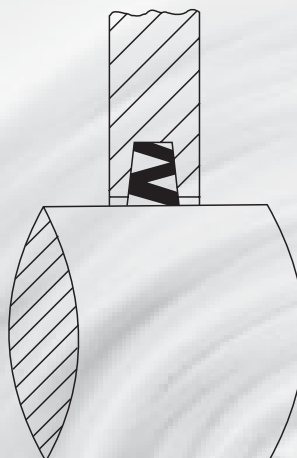

Tenuta in NBR "ZF" per: SN  
*"ZF" NBR seals for: SN*

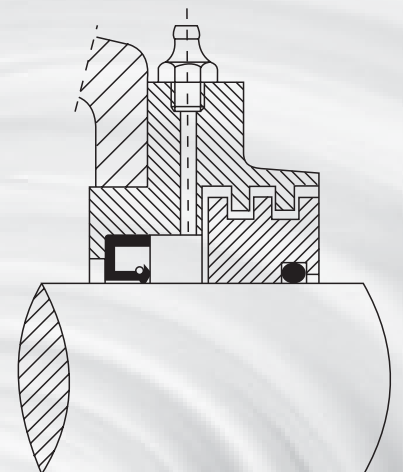

Chiusura di taconite "TAC" per: SN-SD  
*"TAC" taconite cover for: SN-SD*



### A: MATERIALI - MATERIALS:

#### 1. SEDE - HOUSING:

Materiale Material	Carico di rottura Tensile strength kgf/mm <sup>2</sup>	Carico di snervamento Yield strength kgf/mm <sup>2</sup>	Allungamento Elongation	Codice Jis Jis code	Codice USA U.S. code
GHISA CAST IRON	20	-	-	G 5501 (FC 200)	ASTM A 48 GRADO/GRADE 35
ACCIAIO DUTTILE DUCTILE IRON (S. G.)	45	30	10%	G 5502 (FCD 450)	ASTM A 536 GRADO/GRADE 65-45-12

#### 2. ACCESSORI - ACCESSORIES:

Dispositivi di chiusura Sealing arrangements	Sigla Ref.	Per For	Materiali Materials
TENUTA IN POLIURETANO POLYURETHAN SEAL	TSNG	SNG-SNU	Poliuretano Polyurethan
TENUTA IN GOMMA U-LOCK RUBBER SEAL	TSNU	SNG-SNU	Gomma Rubber
TENUTA IN FELTRO FELT SEAL	TSNC	SNG-SNU	Feltro Felt
TENUTA V-RING V-RING SEAL	TSNA	SNG-SNU	NBR NBR
TENUTA LABIRINTO LABYRINTH SEAL	TSNS	SNG-SNU	Ghisa Cast iron
COPERCHIO DI CHIUSURA END COVER	A	SNG-SNU-SN	NBR e lamiera in acciaio NBR and Carbon steel platè
TENUTA LABIRINTO LABYRINTH SEAL	TS	SN-SD	Ghisa Cast iron
CHIUSURA DI TACONITE TACONITE COVER TAC	TAC	SD	Ghisa Cast iron

#### 3. TOLLERANZE - TOLERANCES:

(mm.)

TOLLERANZA DELLA FUSIONE CASTING TOLERANCE	Dimensioni - Dimensions	Tolleranze - Tolerances
	1-100	± 1,5
100-200	± 2,0	
200-400	± 3,0	
400-800	± 4,0	
800-1600	± 5,0	



**TOLLERANZE DI LAVORAZIONE - MACHINE TOLERANCES**

**1. DIAMETRO DEL FORO (D) - DIAMETER BORE (D)**

( $\mu\text{m}$ )

Diametro del foro (mm) Bore diameter (mm)	G7	H7	H8	J7
10-18	+24 +26	-18 -0	+27 -0	+10 -8
18-30	+28 +7	+21 -0	+33 -0	+12 -9
30-50	+34 +9	+25 -0	+39 -0	+14 -11
50-80	+40 +10	+30 -0	+46 -0	+18 -12
80-120	+42 +12	+35 -0	+54 -0	+22 -13
120-180	+54 +14	+40 -0	+63 -0	+26 -14
180-250	+61 +15	+46 -0	+72 -0	+30 -16
250-315	+69 +17	+52 -0	+81 -0	+36 -16
315-400	+75 +18	+57 -0	+89 -0	+39 -18
400-500	+83 +20	+63 -0	+97 -0	+43 -20
500-620	+92 +23	+69 -0	+104 -0	+46 -23

**2. ALTRE TOLLERANZE, ECCETTO FORO (D) - OTHER TOLERANCES, EXCEPT BORE (D)**

( $\mu\text{m}$ )

Dimensioni (mm) Dimensions (mm)	js11	H12	H13	h12	h13
18-30	$\pm 65$	+210 -0	+330 -0	+0 -210	+0 -330
30-50	$\pm 80$	+250 -0	+390 -0	+0 -250	+0 -390
50-80	$\pm 95$	+300 -0	+460 -0	+0 -300	+0 -460
80-120	$\pm 110$	+350 -0	+540 -0	+0 -350	+0 -540
120-180	$\pm 125$	+400 -0	+630 -0	+0 -400	+0 -630
180-250	$\pm 145$	+460 -0	+720 -0	+0 -460	+0 -720
250-315	$\pm 160$	+520 -0	+810 -0	+0 -520	+0 -810
315-400	$\pm 180$	+570 -0	+890 -0	+0 -570	+0 -890

**3. TOLLERANZE SUGGERITE PER SEDE CUSCINETTO - RECOMMENDED FITS OF BEARING HOUSING TOLERANCE**

SUPPORTO UNICO O IN DUE PEZZI	Condizioni di carico Load conditions		Esempio di riferimento Reference example	Tolleranze Tolerances	Anello esterno Outer ring
	Direzione di carico non determinante Direction of load indeterminate	Carico normale e leggero Normal and light load	Motori elettrici, pompe Electric motors, pumps	J7	Possibilità di spostamento Can be displaced
SPLIT OR SOLID HOUSING	Carico dell'anello interno rotante Rotating inner ring load	Carichi di tutti i tipi Loads of a kinds	Applicazioni generali di cuscinetti e boccole Bearings and bushes general applications	H7	Possibilità di facile spostamento Can easily be displaced
	Carico dell'anello interno rotante Rotating inner ring load	Carico leggero e normale Normal and light load	Supporti Bearing housings	H8	Possibilità di facile spostamento Can easily be displaced
	Carico dell'anello interno rotante Rotating inner ring load	Incremento della temperatura dell'anello interno attraverso l'albero High temperature rise of inner ring through shaft	Essicatoti per carta Paper dryers	J7	Possibilità di facile spostamento Can easily be displaced

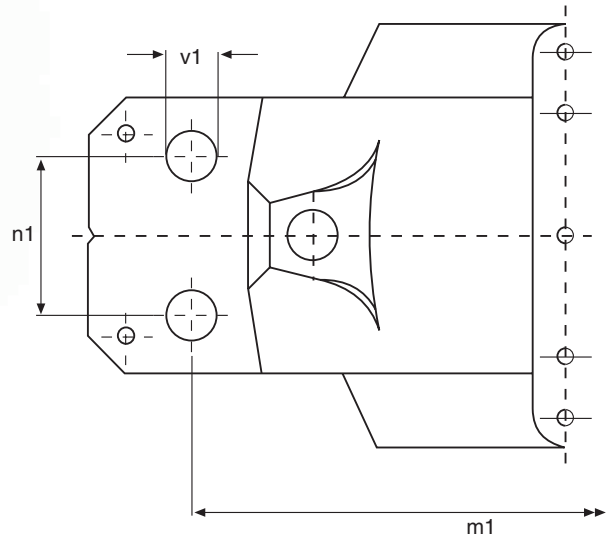
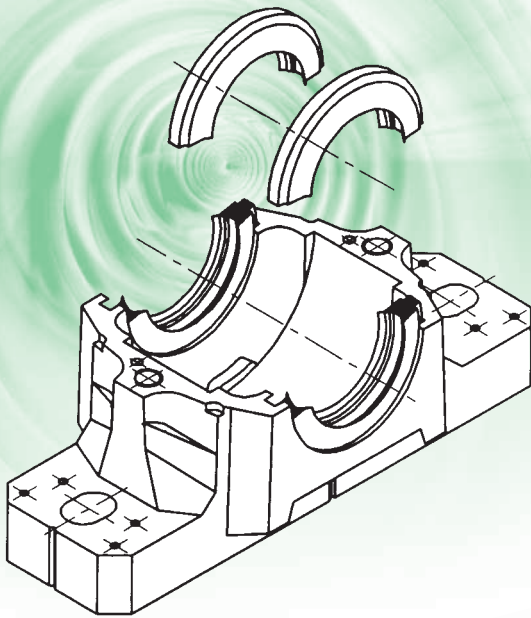

TENUTE "TSNG" SIA PER ALBERI METRICI CHE IN POLLICI  
"TSNG" SEALS FIT BOTH METRIC & INCHES SHAFTS

DISPONIBILE PER MONTAGGIO A QUATTRO-FORI  
AVAILABLE FOR FOUR-BOLT MOUNTING

Tipo Type	m1	n1	v1	Bull. fiss. Bolt Size mm	Tenuta Seal	Diametro albero Shaft diameter			Tenuta Seal	Diametro albero Shaft diameter		
						mm mm	pollici inch			mm mm	pollici inch	
SNG 507-606D	-	-	-	-	TSNG 507	30	1 1/8	1 3/16	TSNG 607	30	1 1/8	1 3/16
SNG 508-607D	160	34	11	M10	TSNG 508	35	1 5/16	1 3/8	TSNG 608	35	1 5/16	1 3/8
SNG 509D	160	34	11	M10	TSNG 509	40	1 1/2	1 9/16	TSNG 609	40	1 1/2	1 9/16
SNG 510-608D	160	34	11	M10	TSNG 510	45	1 11/16	1 3/4	TSNG 610	45	1 11/16	1 3/4
SNG 511-609D	200	40	14	M12	TSNG 511	50	1 15/16	2	TSNG 611	50	1 15/16	2
SNG 512-610D	200	40	14	M12	TSNG 512	55	2 1/8	2 3/16	TSNG 612	55	2 1/8	2 3/16
SNG 513-611D	220	48	14	M12	TSNG 513	60	2 1/4	2 5/16	TSNG 613	60	2 1/4	2 5/16
SNG 515-612D	220	48	14	M12	TSNG 515	65	2 7/16	2 1/2	TSNG 615	65	2 7/16	2 1/2
SNG 516-613D	252	52	18	M16	TSNG 516	70	2 11/16	2 3/4	TSNG 616	70	2 11/16	2 3/4
SNG 517D	252	52	18	M16	TSNG 517	75	2 15/16	3	TSNG 617	75	2 15/16	3
SNG 518-615D	280	58	18	M16	TSNG 518	80	3 1/16	3 1/4	TSNG 618	80	3 1/16	3 1/4
SNG 519-616D	280	58	18	M16	TSNG 519	85	3 5/16	3 3/8	TSNG 619	85	3 5/16	3 3/8
SNG 520-617D	300	66	18	M16	TSNG 520	90	3 7/16	3 1/2	TSNG 620	90	3 7/16	3 1/2
SNG 522-619D	320	74	18	M16	TSNG 522	100	3 15/16	4	-	-	-	-
SNG 524-620D	330	74	18	M16	TSNG 524	110	4 3/16	4 1/4	-	-	-	-
SNG 526D	370	80	22	M20	TSNG 526	115	4 7/16	4 1/2	-	-	-	-
SNG 528D	400	92	26	M24	TSNG 528	125	4 15/16	5	-	-	-	-
SNG 530D	430	100	26	M24	TSNG 530	135	5 3/16	5 1/4	-	-	-	-
SNG 532D	450	100	26	M24	TSNG 532	140	5 7/16	5 1/2	-	-	-	-



**INTERCAMBIABILE CON SUPPORTI SNH, SNU, SNA.**  
**INTER-EXCHANGEABLE WITH BEARING HOUSINGS SNH, SNU, SNA.**

**Possibilità di scelta per collocazione  
ingrassatori ed oliatori**

*Various choice of oil/grease  
locations*

**Punzonature per eventuale  
applicazione di perni di riferimento**

*Dimples provider for  
locating pins if required*

**Molteplici zone per l'installazione  
di sensori**

*Various sensor/monitor  
installing spaces*

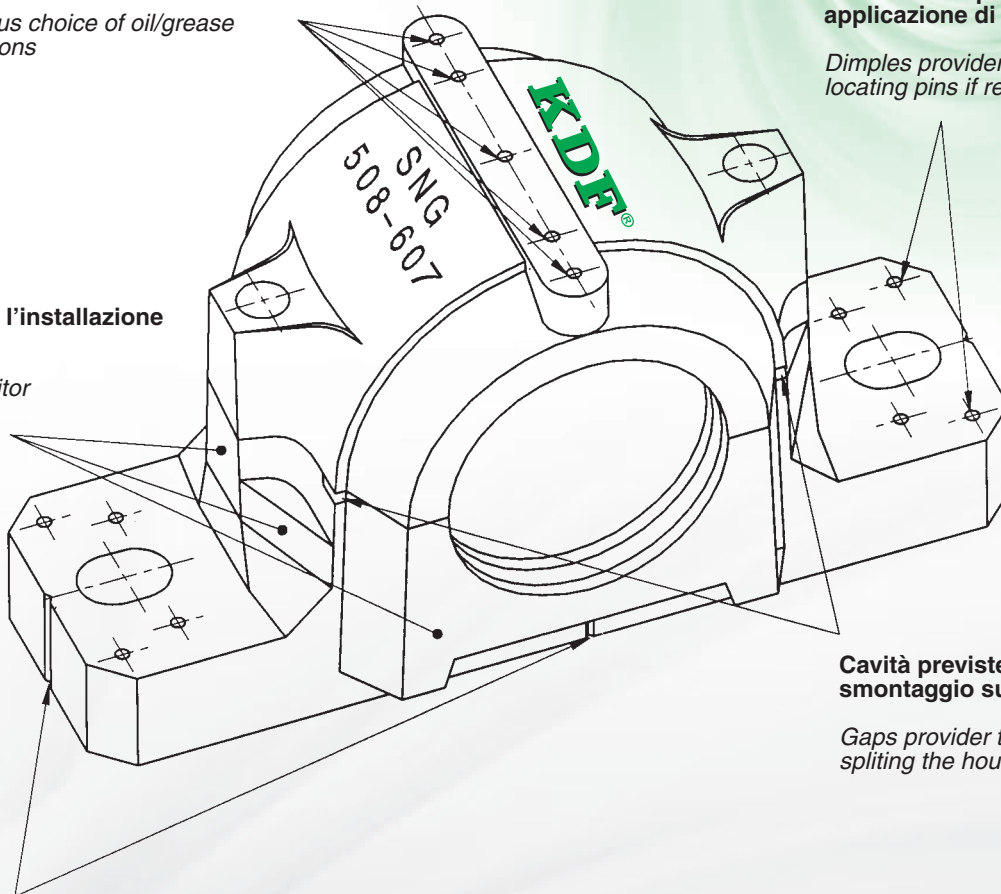

**Cavità previste per  
smontaggio supporto**

*Gaps provider to help  
splitting the housings*

**Linee di riferimento centrali  
per facilitare l'allineamento nel montaggio**

*Cross center lines for easy  
alignment in assembly*

**Base rinforzata per carichi pesanti**

*Reinforced base for heavy load*

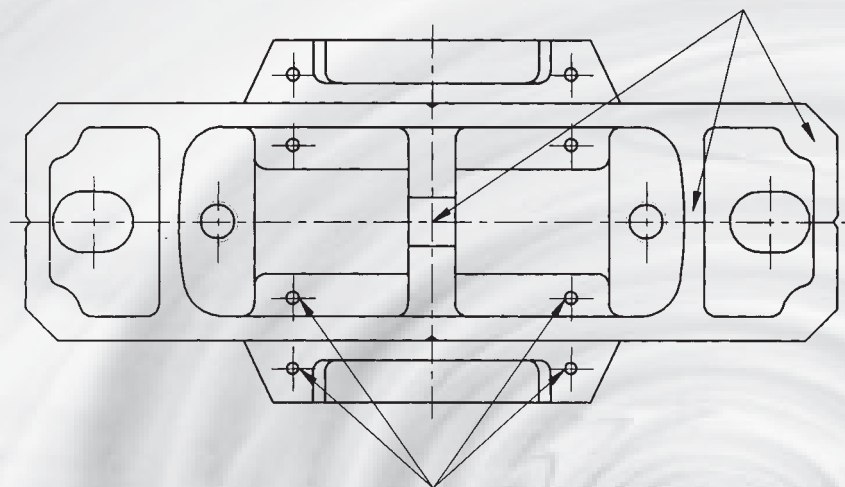

**Otto locazioni selezionate per il drenaggio**

*Eight location selected for drainage*

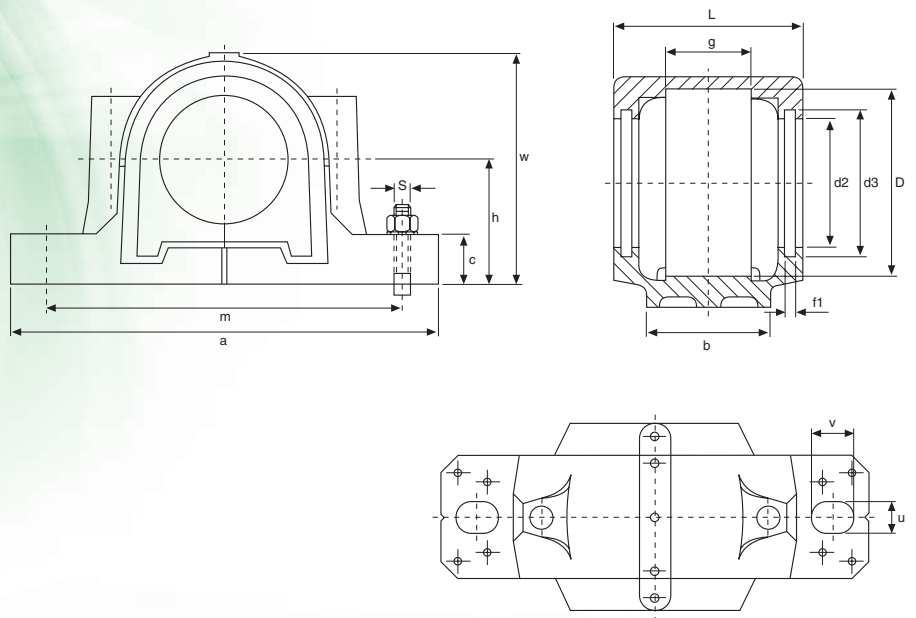

Tipo Type	Diametro albero Shaft diameter		Dimensioni mm Dimensions mm														Bull. fiss. Bolt Size	
	mm mm	pollici inch	D H8	a	b	c	g H12	h js11	L	w	m	U	V	d2 H12	d3 H12	f1		S
SNG 507-606	30	1 1/8	1 3/16	72	185	52	22	34	50	82	92	150	15	20	46,5	54,5	5	M12
SNG 508-607	35	1 3/16	1 3/8	80	205	60	25	39	60	85	106	170	15	20	51,5	59,5	5	M12
SNG 509	40	1 1/2	1 9/16	85	205	60	25	30	60	85	109	170	15	20	56,5	64,5	5	M12
SNG 510-608	45	1 11/16	1 3/4	90	205	60	25	41	60	90	112	170	15	20	62	70,5	5	M12
SNG 511-609	50	1 15/16	2	100	255	70	28	44	70	95	127	210	18	23	67	75,5	5	M16
SNG 512-610	55	2 1/8	2 3/16	110	255	70	30	48	70	105	133	210	18	23	72	80,5	5	M16
SNG 513-611	60	2 1/4	2 5/16	120	275	80	30	51	80	110	148	230	18	24	77	85,5	5	M16
SNG 515-612	65	2 5/16	2 1/2	130	280	80	30	56	80	115	154	230	18	26	87	95,5	5	M16
SNG 516-613	70	2 11/16	2 3/4	140	315	90	32	58	95	120	175	260	22	29	92,5	101	5	M20
SNG 517	75	2 15/16	3	150	320	90	32	61	95	125	181	260	22	30	97,5	106	5	M20
SNG 518-615	80	3 1/16	3 1/4	160	345	100	35	65	100	140	192	290	22	27	102,5	111	5	M20
SNG 519-616	85	3 3/16	3 3/8	170	345	100	35	68	112	145	209	290	22	27	131	141	6	M20
SNG 520-617	90	3 7/16	3 1/2	180	380	110	40	70	112	160	215	320	26	32	137,5	147,5	6	M24
SNG 522-619	100	3 15/16	4	200	410	120	45	80	125	175	239	350	26	32	147,5	157,5	6	M24
SNG 524-620	110	4 3/16	4 1/4	215	410	120	45	86	140	185	271	350	26	32	157,5	167,5	6	M24
SNG 526	115	4 7/16	4 1/2	230	445	130	50	90	150	190	290	380	28	35	167,5	177,5	6	M24
SNG 528	125	4 15/16	5	250	500	150	50	98	150	205	302	420	35	42	177,5	187,5	6	M30
SNG 530	135	5 3/16	5 1/4	270	530	160	60	106	160	220	323	450	35	42	192,5	202,5	6	M30
SNG 532	140	5 7/16	5 1/2	290	550	160	60	114	170	235	344	470	35	42	202,5	212,5	6	M30





**SNG 500**

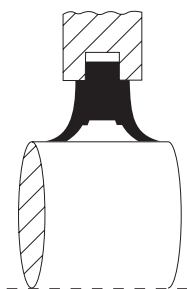

Tenuta in poliuretano "TSNG" per: SNG-SNU  
"TSNG" polyurethan seal for: SNG-SNU

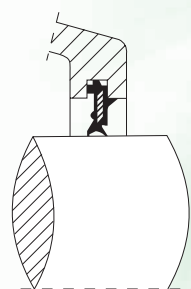

Tenuta in gomma "TSNU" per: SNG-SNU  
"TSNU" rubber seal for: SNG-SNU

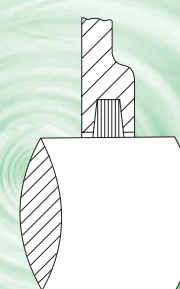

Tenuta in feltro "TSNC" per: SNG-SNU  
"TSNC" felt seal for: SNG-SNU

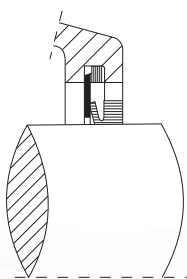

Tenuta v-ring "TSNA" per: SNG-SNU  
"TSNA" v-ring seal for: SNG-SNU

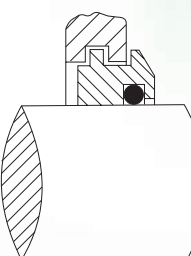

Tenuta a labirinto "TSNS" per: SNG-SNU  
"TSNS" labyrinth seal for: SNG-SNU

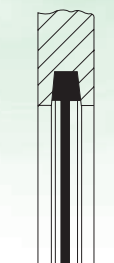

Coperchio di chiusura "A" per: SNG-SNU-SN  
"A" end cover for: SNG-SNU-SN

Cuscinetto orientabile a sfere (foro conico) Self-aligning ball bearing (conical bore)	Cuscinetto orientabile a rulli (foro conico) Self-aligning roller bearing (conical bore)	Bussola (metrica) Adapter sleeve (metric)	Anello di centraggio Locating ring		Peso Weight (Kg)	"TSNG" Tenuta in poliuretano Polyurethan seal	"TSNU" Tenuta in gomma Rubber seal	"TSNC" Tenuta in feltro Felt seal	"TSNA" Tenuta V-Ring V-Ring seal	"TSNS" Tenuta a labirinto Labyrinth seal	"A" Coperchio di chiusura End cover	Tipo Type
			Tipo Type	Q.tà Q.ty								
1207 K 2207 K	- 22207 K	H 207 H 307	SR 72x8,5 SR 72x5,5	2 2	2,2	TSNG 507	TSNU 507	TSNC 507	TSNA 507	TSNS 507	A 507-606	<b>SNG 507-606</b>
1208 K 2208 K	- 22208 K	H 208 H 308	SR 80x10,5 SR 80x8	2 2	2,8	TSNG 508	TSNU 508	TSNC 508	TSNA 508	TSNS 508	A 508-607	<b>SNG 508-607</b>
1209 K 2209 K	- 22209 K	H 209 H 309	SR 85x5,5 SR 85x7	2 1	3,0	TSNG 509	TSNU 509	TSNC 509	TSNA 509	TSNS 509	A 509	<b>SNG 509</b>
1210 K 2210 K	- 22210 K	H 210 H 310	SR 90x10,5 SR 90x9	2 2	3,1	TSNG 510	TSNU 510	TSNC 510	TSNA 510	TSNS 510	A 510-608	<b>SNG 510-608</b>
1211 K 2211 K	- 22211 K	H 211 H 311	SR 100x11,5 SR 100x9,5	2 2	4,5	TSNG 511	TSNU 511	TSNC 511	TSNA 511	TSNS 511	A 511-609	<b>SNG 511-609</b>
1212 K 2212 K	- 22212 K	H 212 H 312	SR 110x13 SR 110x10	2 2	5,0	TSNG 512	TSNU 512	TSNC 512	TSNA 512	TSNS 512	A 512-610	<b>SNG 512-610</b>
1213 K 2213 K	- 22213 K	H 213 H 313	SR 120x14 SR 120x10	2 2	6,1	TSNG 513	TSNU 513	TSNC 513	TSNA 513	TSNS 513	A 513-611	<b>SNG 513-611</b>
1215 K 2215 K	- 22215 K	H 215 H 315	SR 130x15,5 SR 130x12,5	2 2	6,5	TSNG 515	TSNU 515	TSNC 515	TSNA 515	TSNS 515	A 515-612	<b>SNG 515-612</b>
1216 K 2216 K	- 22216 K	H 216 H 316	SR 140x16 SR 140x12,5	2 2	9,0	TSNG 516	TSNU 516	TSNC 516	TSNA 516	TSNS 516	A 516-613	<b>SNG 516-613</b>
1217 K 2217 K	- 22217 K	H 217 H 317	SR 150x16,5 SR 150x12,5	2 2	10,2	TSNG 517	TSNU 517	TSNC 517	TSNA 517	TSNS 517	A 517	<b>SNG 517</b>
1218 K 2218 K	- 22218 K 23218 K	H 218 H 318 H 2318	SR 160x17,5 SR 160x12,5 SR 160x12,5	2 2 1	12,4	TSNG 518	TSNU 518	TSNC 518	TSNA 518	TSNS 518	A 518-615	<b>SNG 518-615</b>
1219 K 2219 K	- 22219 K	H 219 H 319	SR 170x18 SR 170x12,5	2 2	13,5	TSNG 519	TSNU 519	TSNC 519	TSNA 519	TSNS 519	A 519-616	<b>SNG 519-616</b>
2220 K -	22220 K 23220 K	H 320 H 2320	SR 180x12 SR 180x9,7	2 1	17,5	TSNG 520	TSNU 520	TSNC 520	TSNA 520	TSNS 520	A 520-617	<b>SNG 520-617</b>
2222 K -	22222 K 23222 K	H 322 H 2322	SR 200x13,5 SR 200x10	2 1	20,5	TSNG 522	TSNU 522	TSNC 522	TSNA 522	TSNS 522	A 522-619	<b>SNG 522-619</b>
- -	22224 K 23224 K	H 3124 H 2324	SR 215x14 SR 215x10	2 1	25,5	TSNG 524	TSNU 524	TSNC 524	TSNA 524	TSNS 524	A 524-620	<b>SNG 524-620</b>
- -	22226 K 23226 K	H 3126 H 2326	SR 230x13 SR 230x10	2 1	33,0	TSNG 526	TSNU 526	TSNC 526	TSNA 526	TSNS 526	A 526	<b>SNG 526</b>
- -	22228 K 23228 K	H 3128 H 2328	SR 250x15 SR 250x10	2 1	42,0	TSNG 528	TSNU 528	TSNC 528	TSNA 528	TSNS 528	A 528	<b>SNG 528</b>
- -	22230 K 23230 K	H 3130 H 2330	SR 270x16,5 SR 270x10	2 1	53,0	TSNG 530	TSNU 530	TSNC 530	TSNA 530	TSNS 530	A 530	<b>SNG 530</b>
- -	22232 K 23232 K	H 3132 H 2332	SR 290x17 SR 290x10	2 1	55,0	TSNG 532	TSNU 532	TSNC 532	TSNA 532	TSNS 532	A 532	<b>SNG 532</b>

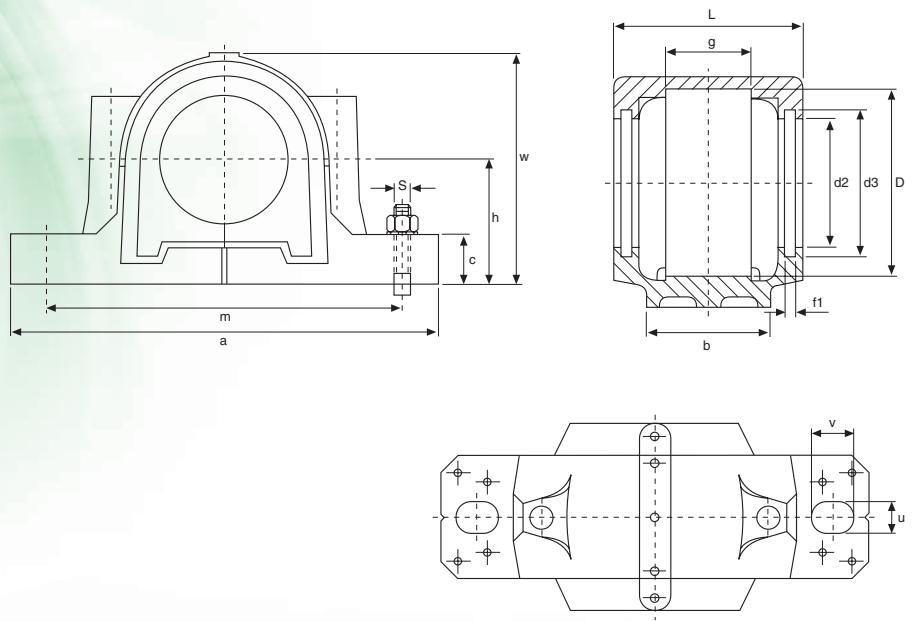

Tipo Type	Diametro albero Shaft diameter		Dimensioni mm Dimensions mm														Bull. fiss. Bolt Size
	mm mm	pollici inch	D H8	a	b	c	g H12	h js11	L	w	m	U	V	d2 H12	d3 H12	f1	
SNG 508-607	30	1 1/8 1 3/16	80	205	60	25	39	60	85	106	170	15	20	51,5	59,5	5	M12
SNG 510-608	35	1 5/16 1 3/8	90	205	60	25	41	60	90	112	170	15	20	62	70,5	5	M12
SNG 511-609	40	1 1/2 1 9/16	100	255	70	28	44	70	95	127	210	18	23	67	75,5	5	M16
SNG 512-610	45	1 11/16 1 3/4	110	255	70	30	48	70	105	133	210	18	23	72	80,5	5	M16
SNG 513-611	50	1 15/16 2	120	275	80	30	51	80	110	148	230	18	24	77	85,5	5	M16
SNG 515-612	55	2 1/8 2 3/16	130	280	80	30	56	80	115	154	230	18	26	87	95,5	5	M16
SNG 516-613	60	2 1/4 2 5/16	140	315	90	32	58	95	120	175	260	22	29	92,5	101	5	M20
SNG 518-615	65	2 7/16 2 1/2	160	345	100	35	65	100	140	192	290	22	27	102,5	111	5	M20
SNG 519-616	70	2 11/16 2 3/4	170	345	100	35	68	112	145	209	290	22	27	131	141	6	M20
SNG 520-617	75	2 15/16 3	180	380	110	40	70	112	160	215	320	26	32	137,5	147,5	6	M24
SNG 522-619	85	3 5/16 3 3/8	200	410	120	45	80	125	175	239	350	26	32	147,5	157,5	6	M24
SNG 524-620	90	3 7/16 3 1/2	215	410	120	45	86	140	185	271	350	26	32	157,5	167,5	6	M24



**SNG 600**

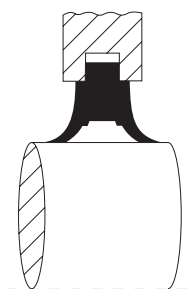

Tenuta in poliuretano "TSNG" per: SNG-SNU  
"TSNG" polyurethan seal for: SNG-SNU

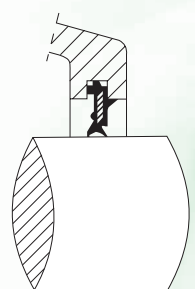

Tenuta in gomma "TSNU" per: SNG-SNU  
"TSNU" rubber seal for: SNG-SNU

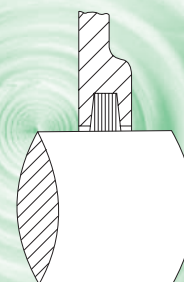

Tenuta in feltro "TSNC" per: SNG-SNU  
"TSNC" felt seal for: SNG-SNU

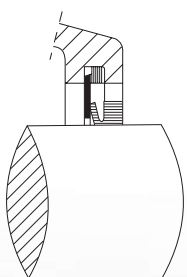

Tenuta v-ring "TSNA" per: SNG-SNU  
"TSNA" v-ring seal for: SNG-SNU

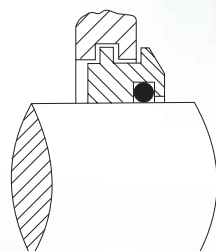

Tenuta a labirinto "TSNS" per: SNG-SNU  
"TSNS" labyrinth seal for: SNG-SNU

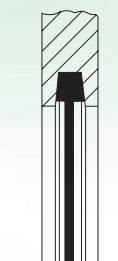

Coperchio di chiusura "A" per: SNG-SNU-SN  
"A" end cover for: SNG-SNU-SN

Cuscinetto orientabile a sfere (foro conico) Self-aligning ball bearing (conical bore)	Cuscinetto orientabile a rulli (foro conico) Self-aligning roller bearing (conical bore)	Bussola (metrica) Adapter sleeve (metric)	Anello di centraggio Locating ring		Peso Weight (Kg)	"TSNG" Tenuta in poliuretano Polyurethan seal	"TSNU" Tenuta in gomma Rubber seal	"TSNC" Tenuta in feltro Felt seal	"TSNA" Tenuta V-Ring V-Ring seal	"TSNS" Tenuta a labirinto Labyrinth seal	"A" Coperchio di chiusura End cover	Tipo Type
			Tipo Type	Q.tà Q.ty								
1307 K 2307 K	-	H 307 H 2307	SR 80x9 SR 80x8	2 1	2,8	TSNG 607	TSNU 607	TSNC 607	TSNA 607	TSNS 607	A 508-607	<b>SNG 508-607</b>
1308 K 2308 K	21308 K 22308 K	H 308 H 2308	SR 90x9 SR 90x8	2 1	3,1	TSNG 608	TSNU 608	TSNC 608	TSNA 608	TSNS 608	A 510-608	<b>SNG 510-608</b>
1309 K 2309 K	21309 K 22309 K	H 309 H 2309	SR 100x9,5 SR 100x8	2 1	4,5	TSNG 609	TSNU 609	TSNC 609	TSNA 609	TSNS 609	A 511-609	<b>SNG 511-609</b>
1310 K 2310 K	21310 K 22310 K	H 310 H 2310	SR 110x10,5 SR 110x8	2 1	5,0	TSNG 610	TSNU 610	TSNC 610	TSNA 610	TSNS 610	A 512-610	<b>SNG 512-610</b>
1311 K 2311 K	21311 K 22311 K	H 311 H 2311	SR 120x11 SR 120x8	2 1	6,1	TSNG 611	TSNU 611	TSNC 611	TSNA 611	TSNS 611	A 513-611	<b>SNG 513-611</b>
1312 K 2312 K	21212 K 22312 K	H 312 H 2312	SR 130x12,5 SR 130x10	2 1	6,5	TSNG 612	TSNU 612	TSNC 612	TSNA 612	TSNS 612	A 515-612	<b>SNG 515-612</b>
1313 K 2313 K	21213 K 22313 K	H 313 H 2313	SR 140x12,5 SR 140x10	2 1	9,0	TSNG 613	TSNU 613	TSNC 613	TSNA 613	TSNS 613	A 516-613	<b>SNG 516-613</b>
1315 K 2315 K	21215 K 22315 K	H 315 H 2315	SR 160x14 SR 160x10	2 1	12,4	TSNG 615	TSNU 615	TSNC 615	TSNA 615	TSNS 615	A 518-615	<b>SNG 518-615</b>
1316 K 2316 K	21316 K 22316 K	H 316 H 2316	SR 170x14,5 SR 170x10	2 1	13,5	TSNG 616	TSNU 616	TSNC 616	TSNA 616	TSNS 616	A 519-616	<b>SNG 519-616</b>
1317 K 2317 K	21317 K 22317 K	H 317 H 2317	SR 180x14,5 SR 180x10	2 1	17,5	TSNG 617	TSNU 617	TSNC 617	TSNA 617	TSNS 617	A 520-617	<b>SNG 520-617</b>
1319 K 2319 K	- 22319 K	H 319 H 2319	SR 200x17,5 SR 200x13	2 1	20,5	TSNG 619	TSNU 619	TSNC 619	TSNA 619	TSNS 619	A 522-619	<b>SNG 522-619</b>
- 2320 K	- 22320 K	H - H 2320	- SR 215x13	- 1	25,5	TSNG 620	TSNU 620	TSNC 620	TSNA 620	TSNS 620	A 524-620	<b>SNG 524-620</b>

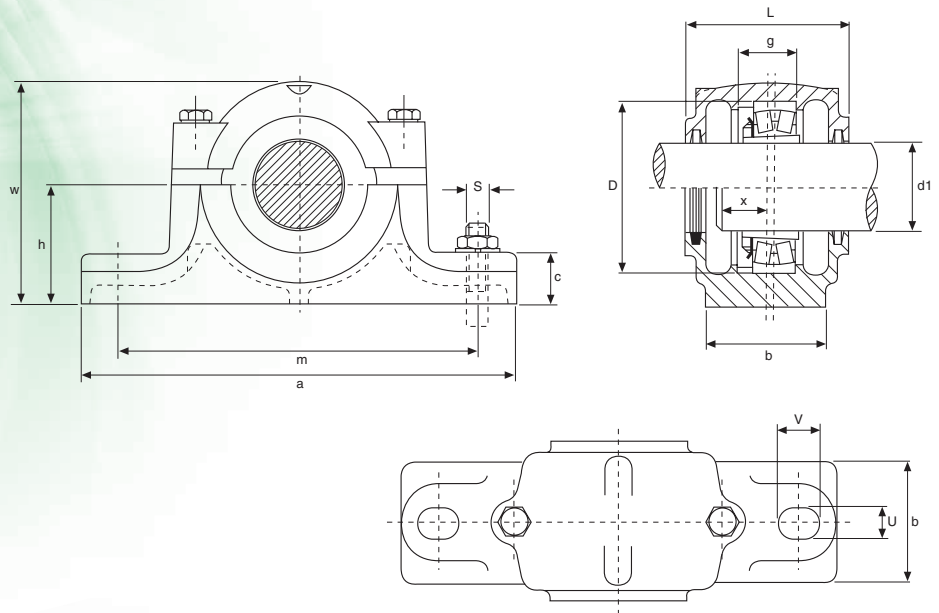

Tipo Type	Diametro albero d1 Shaft diameter d1		Dimensioni mm Dimensions mm											Bull. fiss. Bolt Size
	mm mm	pollici inch	D H8	a	b	c	g H12	h h12	L ± 5	w	m	U	V	
SN 506	25	1	62	185	52	22	30	50	77	90	150	15	20	M12
SN 507	30	1 1/8	72	185	52	22	33	50	82	95	150	15	20	M12
SN 508	35	1 1/4	80	205	60	25	33	60	85	110	170	15	20	M12
SN 509	40	1 1/2	85	205	60	25	31	60	85	112	170	15	20	M12
SN 510	45	1 3/4	90	205	60	25	33	60	90	115	170	15	20	M12
SN 511	50	2	100	255	70	28	33	70	95	130	210	18	23	M16
SN 512	55	2 1/8	110	255	70	30	38	70	105	135	210	18	23	M16
SN 513	60	2 1/4	120	275	80	30	43	80	110	150	230	18	23	M16
SN 515	65	2 1/2	130	280	80	30	41	80	115	155	230	18	23	M16
SN 516	70	2 3/4	140	315	90	32	43	95	120	175	260	22	27	M20
SN 517	75	3	150	320	90	32	46	95	125	185	260	22	27	M20
SN 518	80	3 1/4	160	345	100	35	62,4	100	145	195	290	22	27	M20
SN 519	85	-	170	345	100	35	53	112	140	210	290	22	27	M20
SN 520	90	3 1/2	180	380	110	40	70,3	112	160	218	320	26	32	M24
SN 522	100	4	200	410	120	45	80	125	175	240	350	26	32	M24
SN 524	110	4 1/4	215	410	120	45	86	140	185	270	350	26	32	M24
SN 526	115	4 1/2	230	445	130	50	90	150	190	290	380	28	36	M24
SN 528	125	5	250	500	150	50	98	150	205	305	420	33	42	M30
SN 530	135	5 1/4	270	530	160	60	106	160	220	325	450	33	42	M30
SN 532	140	5 1/2	290	550	160	60	114	170	235	345	470	33	42	M30



**SN 600**

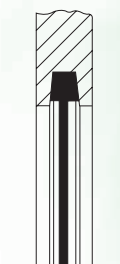
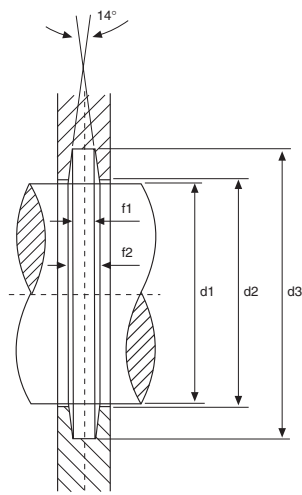

Coperchio di chiusura "A" per: SNG-SNU-SN  
"A" end cover for: SNG-SNU-SN

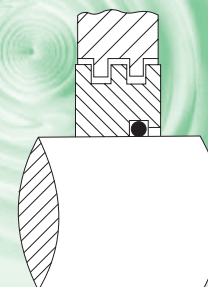

Tenuta a labirinto "TS" per: SN-SD  
"TS" labyrinth seal for: SN-SD

Se non diversamente specificato viene fornito il supporto aperto di tipo "B"  
Unless specified "B" type open housing supplied

X	Dimensioni mm Dimensions mm				Peso Weight (Kg)	Cuscinetto orientabile a sfere (foro conico) Self-aligning ball bearing (conical bore)	Cuscinetto orientabile a rulli (foro conico) Self-aligning roller bearing (conical bore)	Bussola Adapter sleeve		Anello di centraggio Locating ring		"A" Coperchio di chiusura End cover	"TS" Tenuta a labirinto Labyrinth seal	Tipo Type
	d2 H12	d3 H12	f1 H13	f2				mm mm	pollici inch	Tipo Type	Q.tà Q.ty			
22	26,5	38	4	5,4	1,6	1206 K 2206 K	- 22206 K	H 206 H 306	HE 206 HE 306	SR 62x7 SR 62x10	2 1	A 506	TS 506	SN 506
24	31,5	43	4	5,4	2,1	1207 K 2207 K	- 22207 K	H 207 H 307	HE 207 HE 307	SR 72x8 SR 72x10	2 1	A 507	TS 507	SN 507
26	36,5	48	4	5,4	2,7	1208 K 2208 K	- 22208 K	H 208 H 308	HE 208 HE 308	SR 80x7,5 SR 80x10	2 1	A 508	TS 508	SN 508
28	41,5	53	4	5,4	2,8	1209 K 2209 K	- 22209 K	H 209 H 309	HE 209 HE 309	SR 85x6 SR 85x8	2 1	A 509	TS 509	SN 509
28	46,5	58	4	5,4	3,0	1210 K 2210 K	- 22210 K	H 210 H 310	HE 210 HE 310	SR 90x6,5 SR 90x10	2 1	A 510	TS 510	SN 510
30	51,5	67	5	6,9	4,0	1211 K 2211 K	- 22211 K	H 211 H 311	HE 211 HE 311	SR 100x6 SR 100x8	2 1	A 511	TS 511	SN 511
32	56,5	72	5	6,9	4,5	1212 K 2212 K	- 22212 K	H 212 H 312	HE 212 HE 312	SR 110x8 SR 110x10	2 1	A 512	TS 512	SN 512
36	62	77	5	6,8	5,5	1213 K 2213 K	- 22213 K	H 213 H 313	HE 213 HE 313	SR 120x10 SR 120x12	2 1	A 513	TS 513	SN 513
38	67	82	5	6,8	6,0	1215 K 2215 K	- 22215 K	H 215 H 315	HE 215 HE 315	SR 130x8 SR 130x10	2 1	A 515	TS 515	SN 515
40	72	89	6	8,1	8,2	1216 K 2216 K	- 22216 K	H 216 H 316	HE 216 HE 316	SR 140x8,5 SR 140x10	2 1	A 516	TS 516	SN 516
42	77	94	6	8,1	9,0	1217 K 2217 K	- 22217 K	H 217 H 317	HE 217 HE 317	SR 150x9 SR 150x10	2 1	A 517	TS 517	SN 517
50	82	99	6	8,1	11,6	1218 K 2218 K	22218 K 23218 K	H 218 H 318 H 2318	HE 218 HE 318 HE 2318	SR 160x16,2 SR 160x11,2 SR 160x10	2 2 1	A 518	TS 518	SN 518
52	87	104	6	8,1	11,8	1219 K 2219 K	- 22219 K	H 219 H 319	HE 219 HE 319	SR 170x10,5 SR 170x10	2 1	A 519	TS 519	SN 519
54	92	111	7	9,3	15,5	2220 K -	22220 K 23220 K	H 320 H 2320	HE 320 HE 2320	SR 180x12,1 SR 180x10	2 1	A 520	TS 520	SN 520
60	102	125	8	10,8	19	2222 K -	22222 K 23222 K	H 322 H 2322	HE 322 HE 2322	SR 200x13,5 SR 200x10	2 1	A 522	TS 522	SN 522
64	113	135	8	10,7	23	- -	22224 K 23224 K	H 3124 H 2324	HE 3124 HE 2324	SR 215x14 SR 215x10	2 1	A 524	TS 524	SN 524
64	118	140	8	10,7	28	- -	22226 K 23226 K	H 3126 H 2326	HE 3126 HE 2326	SR 230x13 SR 230x10	2 1	A 526	TS 526	SN 526
70	128	154	9	12,2	37	- -	22228 K 23228 K	H 3128 H 2328	HE 3128 HE 2328	SR 250x15 SR 250x10	2 1	A 528	TS 528	SN 528
76	138	164	9	12,2	44	- -	22230 K 23230 K	H 3130 H 2330	HE 3130 HE 2330	SR 270x16,5 SR 270x10	2 1	A 530	TS 530	SN 530
80	143	173	10	13,7	50	- -	22232 K 23232 K	H 3132 H 2332	HE 3132 HE 2332	SR 290x17 SR 290x10	2 1	A 532	TS 532	SN 532

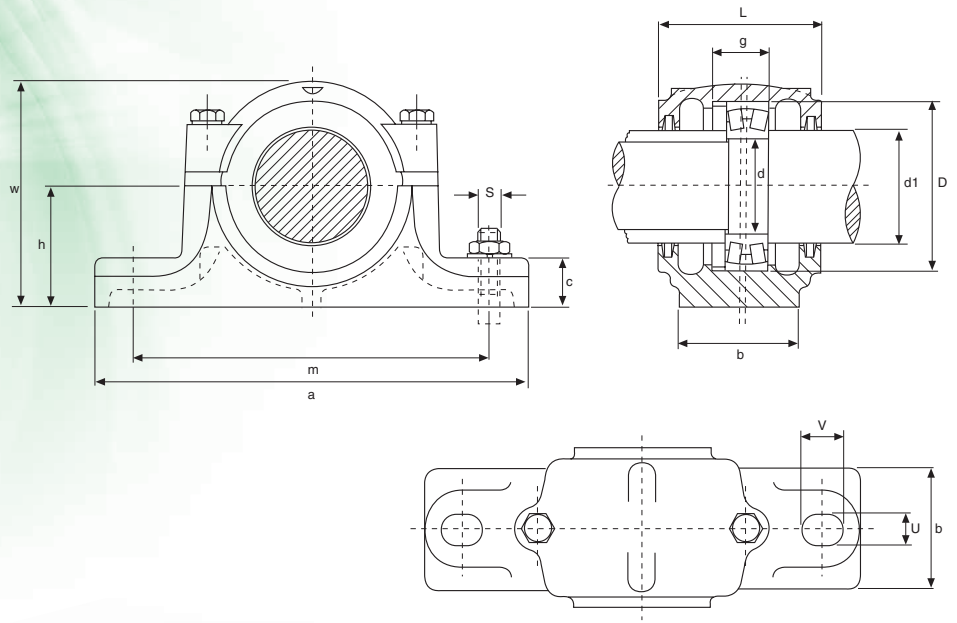

Tipo Type	Diametro albero mm Shaft diameter mm			Dimensioni mm Dimensions mm											
	d	d0	d1	D H8	a	b	c	g H12	h h12	L ± 5	w	m	n	U	V
SN 207	35	30	45	72	185	52	22	33	50	82	95	150	-	15	20
SN 208	40	35	50	80	205	60	25	33	60	85	110	170	-	15	20
SN 209	45	40	55	85	205	60	25	31	60	85	112	170	30	15	20
SN 210	50	45	60	90	205	60	25	33	60	90	115	170	30	15	20
SN 211	55	50	65	100	255	70	28	33	70	95	130	210	35	18	23
SN 212	60	55	70	110	255	70	30	38	70	105	135	210	35	18	23
SN 213	65	60	75	120	275	80	30	43	80	110	150	230	40	18	23
SN 215	75	65	85	130	280	80	30	41	80	115	155	230	40	18	23
SN 216	80	70	90	140	315	90	32	43	95	120	175	260	50	22	27
SN 217	85	75	95	150	320	90	32	46	95	125	185	260	50	22	27
SN 218	90	80	100	160	345	100	35	62,4	100	145	195	290	50	22	27
SN 220	100	90	115	180	380	110	40	70,3	112	160	218	320	60	26	32
SN 222	110	100	125	200	410	120	45	80	125	175	240	350	70	26	32
SN 224	120	110	135	215	410	120	45	86	140	185	270	350	70	26	32
SN 226	130	115	145	230	445	130	50	90	150	190	290	380	70	28	36
SN 228	140	125	155	250	500	150	50	98	150	205	305	420	80	33	42
SN 230	150	135	165	270	530	160	60	106	160	220	325	450	90	33	42
SN 232	160	140	175	290	550	160	60	114	170	235	345	470	90	33	42



**SN 200**

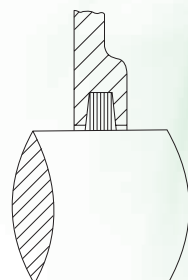
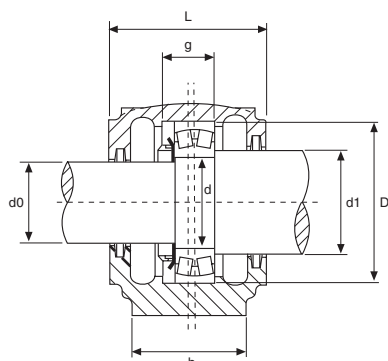

Tenuta in feltro "TSNC" per: SNG-SNU  
"TSNC" felt seal for: SNG-SNU

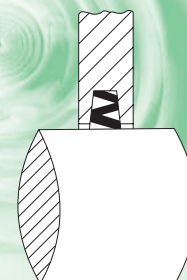

Tenuta in NBR "ZF" per: SN  
"ZF" NBR seal for: SN

S		Cuscinetto orientabile a sfere (foro cilindrico) Self-aligning ball bearing (cylindrical bore)	Cuscinetto orientabile a rulli (foro cilindrico) Self-aligning roller bearing (cylindrical bore)	Ghiera di bloccaggio Lock nut	Rosetta Washer	"TSNC" Tenuta in feltro Felt seal		"ZF" Tenuta in NBR NBR seal		Anello di centraggio Locating ring		Tipo Type
2 Bull. Fiss. 2 Bolt size	4 Bull. Fiss. 4 Bolt size					KM	MB	d0	d1	d0	d1	
M 12	-	1207 2207	22207	KM 07	MB 07	TSNC 207	TSNC 210	ZF 207	ZF 210	SR 72x8 SR 72x10	2 1	SN 207
M 12	-	1208 2208	22208	KM 08	MB 08	TSNC 208	TSNC 211	ZF 208	ZF 211	SR 80x7,5 SR 80x10	2 1	SN 208
M 12	M 10	1209 2209	22209	KM 09	MB 09	TSNC 209	TSNC 212	ZF 209	ZF 212	SR 85x6 SR 85x8	2 1	SN 209
M 12	M 10	1210 2210	22210	KM 10	MB 10	TSNC 210	TSNC 213	ZF 210	ZF 213	SR 90x6,5 SR 90x10	2 1	SN 210
M 16	M 12	1211 2211	22211	KM 11	MB 11	TSNC 211	TSNC 215	ZF 211	ZF 215	SR 100x6 SR 100x8	2 1	SN 211
M 16	M 12	1212 2212	22212	KM 12	MB 12	TSNC 212	TSNC 216	ZF 212	ZF 216	SR 110x8 SR 110x10	2 1	SN 212
M 16	M 12	1213 2213	22213	KM 13	MB 13	TSNC 213	TSNC 217	ZF 213	ZF 217	SR 120x10 SR 120x12	2 1	SN 213
M 16	M 12	1215 2215	22215	KM 15	MB 15	TSNC 215	TSNC 219	ZF 215	ZF 219	SR 130x8 SR 130x10	2 1	SN 215
M 20	M 16	1216 2216	22216	KM 16	MB 16	TSNC 216	TSNC 220	ZF 216	ZF 220	SR 140x8,5 SR 140x10	2 1	SN 216
M 20	M 16	1217 2217	22217	KM 17	MB 17	TSNC 217	TSNC 221	ZF 217	ZF 221	SR 150x9 SR 150x10	2 1	SN 217
M 20	M 16	1218 2218	22218 23218	KM 18	MB 18	TSNC 218	TSNC 222	ZF 218	ZF 222	SR 160x16,2 SR 160x11,2 SR 160x10	2 2 1	SN 218
M 24	M 16	2220	22220 23220	KM 20	MB 20	TSNC 220	TSNC 226	ZF 220	ZF 226	SR 180x12,1 SR 180x10	2 1	SN 220
M 24	M 16	2222	22222 23222	KM 22	MB 22	TSNC 222	TSNC 228	ZF 222	ZF 228	SR 200x13,5 SR 200x10	2 1	SN 222
M 24	M 16	-	22224 23224	KM 24	MB 24	TSNC 224	TSNC 230	ZF 224	ZF 230	SR 215x14 SR 215x10	2 1	SN 224
M 24	M 20	-	22226 23226	KM 26	MB 26	TSNC 226	TSNC 233	ZF 226	ZF 233	SR 230x13 SR 230x10	2 1	SN 226
M 30	M 24	-	22228 23228	KM 28	MB 28	TSNC 228	TSNC 235	ZF 228	ZF 235	SR 250x15 SR 250x10	2 1	SN 228
M 30	M 24	-	22230 23230	KM 30	MB 30	TSNC 230	TSNC 237	ZF 230	ZF 237	SR 270x16,5 SR 270x10	2 1	SN 230
M 30	M 24	-	22232 23232	KM 32	MB 32	TSNC 232	TSNC 239	ZF 232	ZF 239	SR 290x17 SR 290x10	2 1	SN 232

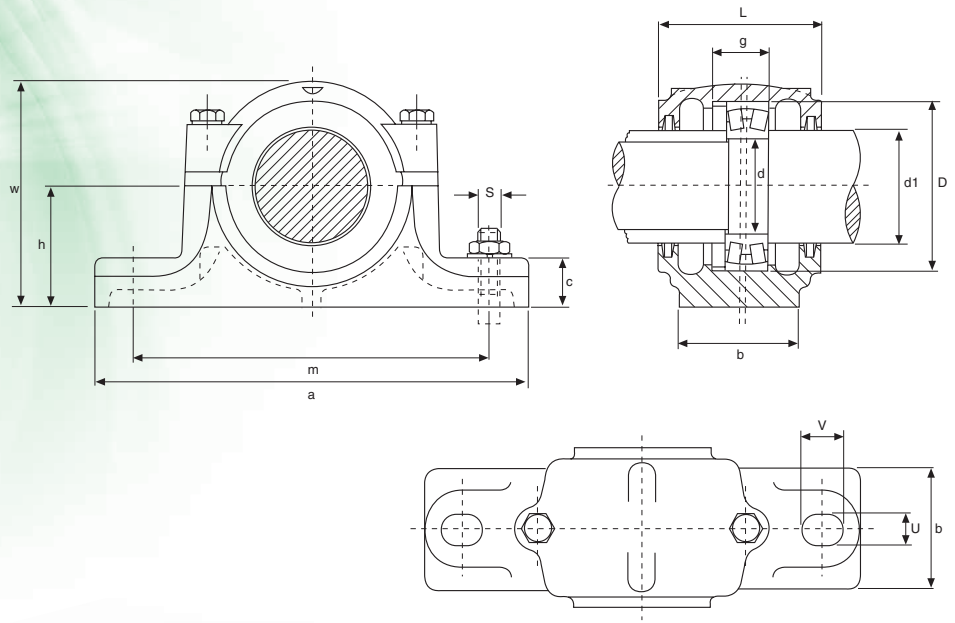

Tipo Type	Diametro albero mm Shaft diameter mm			Dimensioni mm Dimensions mm											
	d	d0	d1	D H8	a	b	c	g H12	h h12	L ± 5	w	m	n	U	V
SN 307	35	30	45	80	205	60	25	41	60	90	110	170	-	15	20
SN 308	40	35	50	90	205	60	25	43	60	95	115	170	-	15	20
SN 309	45	40	55	100	255	70	28	46	70	105	130	210	-	18	23
SN 310	50	45	60	110	255	70	30	50	70	115	135	210	-	18	23
SN 311	55	50	65	120	275	80	30	53	80	120	150	230	40	18	23
SN 312	60	55	70	130	280	80	30	56	80	125	155	230	40	18	23
SN 313	65	60	75	140	315	90	32	58	95	130	175	260	50	22	27
SN 315	75	65	85	160	345	100	35	65	100	140	195	290	50	22	27
SN 316	80	70	90	170	345	100	35	68	112	145	212	290	50	22	27
SN 317	85	75	95	180	380	110	40	70	112	155	218	320	60	26	32
SN 318	90	80	100	190	400	110	33	74	112	160	230	320	60	26	35
SN 319	95	85	110	200	420	120	36	77	125	170	245	350	70	26	35
SN 320	100	90	115	215	420	120	38	83	140	175	280	350	70	26	35
SN 322	110	100	125	240	460	130	40	90	150	190	300	390	70	28	38
SN 324	120	110	135	260	540	160	50	96	160	205	325	450	90	33	42
SN 326	130	115	150	280	560	160	50	103	170	215	350	470	90	33	42
SN 328	140	125	160	300	630	170	55	112	180	235	375	520	90	35	45
SN 330	150	135	170	320	680	180	55	118	190	245	395	560	90	35	45
SN 332	160	140	180	340	710	190	60	124	200	255	415	580	100	42	52





**SN 300**

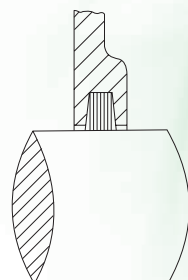
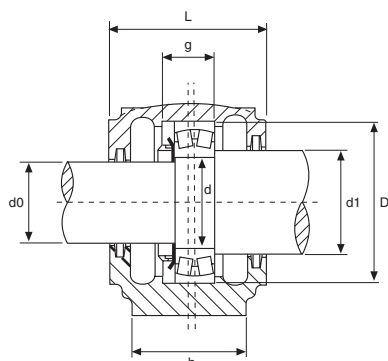

Tenuta in feltro "TSNC" per: SNG-SNU  
"TSNC" felt seal for: SNG-SNU

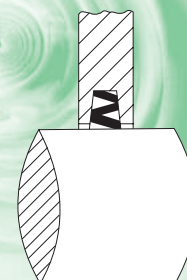

Tenuta in NBR "ZF" per: SN  
"ZF" NBR seal for: SN

S		Cuscinetto orientabile a sfere (foro cilindrico) Self-aligning ball bearing (cylindrical bore)	Cuscinetto orientabile a rulli (foro cilindrico) Self-aligning roller bearing (cylindrical bore)	Ghiera di bloccaggio Lock nut	Rosetta Washer	"TSNC" Tenuta in feltro Felt seal		"ZF" Tenuta in NBR NBR seal		Anello di centraggio Locating ring		Tipo Type
2 Bull. Fiss. 2 Bolt size	4 Bull. Fiss. 4 Bolt size					KM	MB	d0	d1	d0	d1	
M 12	-	1307 2307	-	KM 07	MB 07	TSNC 307	TSNC 310	ZF 307	ZF 310	SR 80x10 SR 80x10	2 1	SN 307
M 12	-	1308 2308	21308 22308	KM 08	MB 08	TSNC 308	TSNC 311	ZF 308	ZF 311	SR 90x10 SR 90x10	2 1	SN 308
M 16	-	1309 2309	21309 22309	KM 09	MB 09	TSNC 309	TSNC 312	ZF 309	ZF 312	SR 100x10,5 SR 100x10	2 1	SN 309
M 16	-	1310 2310	21310 22310	KM 10	MB 10	TSNC 310	TSNC 313	ZF 310	ZF 313	SR 110x11,5 SR 110x10	2 1	SN 310
M 16	M 12	1311 2311	21311 22311	KM 11	MB 11	TSNC 311	TSNC 315	ZF 311	ZF 315	SR 120x12 SR 120x10	2 1	SN 311
M 16	M 12	1312 2312	21312 22312	KM 12	MB 12	TSNC 312	TSNC 316	ZF 312	ZF 316	SR 130x12,5 SR 130x10	2 1	SN 312
M 20	M 16	1313 2313	21313 22313	KM 13	MB 13	TSNC 313	TSNC 317	ZF 313	ZF 317	SR 140x12,5 SR 140x10	2 1	SN 313
M 20	M 16	1315 2315	21315 22315	KM 15	MB 15	TSNC 315	TSNC 319	ZF 315	ZF 319	SR 160x14 SR 160x10	2 1	SN 315
M 20	M 16	1316 2316	21316 22316	KM 16	MB 16	TSNC 316	TSNC 320	ZF 316	ZF 320	SR 170x14,5 SR 170x10	2 1	SN 316
M 24	M 16	1317 2317	21317 22317	KM 17	MB 17	TSNC 317	TSNC 321	ZF 317	ZF 321	SR 180x14,5 SR 180x10	2 1	SN 317
M 24	M 16	1318 2318	21318 22318	KM 18	MB 18	TSNC 318	TSNC 322	ZF 318	ZF 322	SR 190x15,5 SR 190x10	2 1	SN 318
M 24	M 16	1319 2319	21319 22319	KM 19	MB 19	TSNC 319	TSNC 324	ZF 319	ZF 324	SR 200x16 SR 200x10	2 1	SN 319
M 24	M 16	1320 2320	21320 22320	KM 20	MB 20	TSNC 320	TSNC 326	ZF 320	ZF 326	SR 215x18 SR 215x10	2 1	SN 320
M 24	M 16	1322 2322	22322	KM 22	MB 22	TSNC 322	TSNC 328	ZF 322	ZF 328	SR 240x20 SR 240x10	2 1	SN 322
M 30	M 20	-	22324	KM 24	MB 24	TSNC 324	TSNC 330	ZF 324	ZF 330	SR 260x10	1	SN 324
M 30	M 20	-	22326	KM 26	MB 26	TSNC 326	TSNC 334	ZF 326	ZF 334	SR 280x 10	1	SN 326
M 30	M 20	-	22328	KM 28	MB 28	TSNC 328	TSNC 336	ZF 328	ZF 336	SR 300x10	1	SN 328
M 30	M 20	-	22330	KM 30	MB 30	TSNC 330	TSNC 338	ZF 330	ZF 338	SR 320x10	1	SN 330
M 36	M 24	-	22332	KM 32	MB 32	TSNC 332	TSNC 340	ZF 332	ZF 340	SR 340x10	1	SN 332

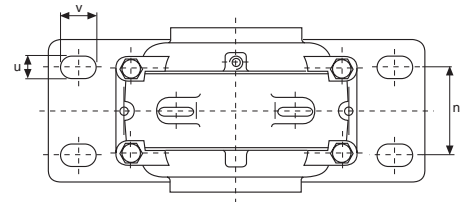
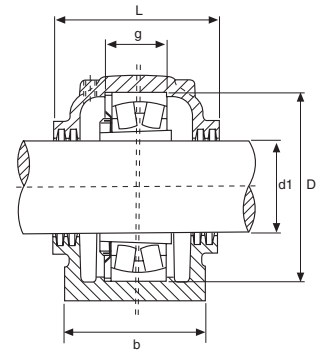
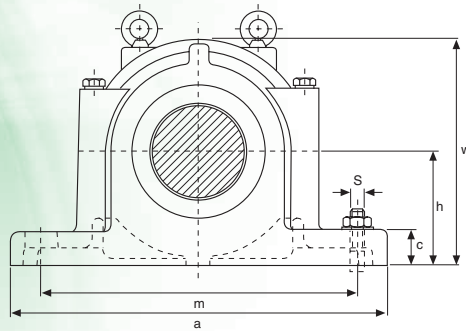

Tipo Type	Diametro albero Shaft diameter	Dimensioni mm Dimensions mm											
		d1	D H8	a	b	c	g H12	h h12	L ± 5	w	m	n	U
SD 3034	150	260	540	200	50	77	160	230	320	450	110	36	52
SD 3036	160	280	560	220	50	84	170	250	340	470	120	36	52
SD 3038	170	290	560	220	50	85	170	250	345	470	120	36	52
SD 3040	180	310	620	230	60	92	180	270	360	510	140	36	52
SD 3044	200	340	700	260	65	100	200	290	400	570	160	36	55
SD 3048	220	360	740	270	65	102	210	300	420	610	170	36	55
SD 3052	240	400	820	300	70	114	240	330	475	680	190	43	62
SD 3056	260	420	860	320	85	116	250	350	500	710	200	43	62
SD 3060	280	460	920	330	85	128	280	360	550	770	210	43	62
SD 3064	300	480	940	340	85	131	280	370	560	790	210	43	62
SD 3068	320	520	1020	370	100	143	310	400	615	860	230	50	70
SD 3072	340	540	1060	390	100	144	325	410	640	890	250	50	70
SD 3076	360	560	1080	390	100	145	340	410	665	900	260	50	70



**SD 3000**

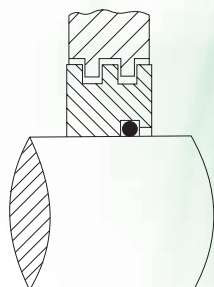
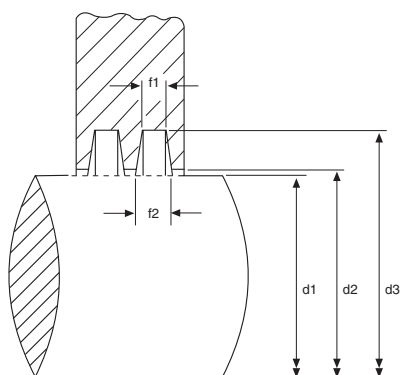

Tenuta a labirinto "TS" per: SN-SD  
"TS" labyrinth seal for: SN-SD

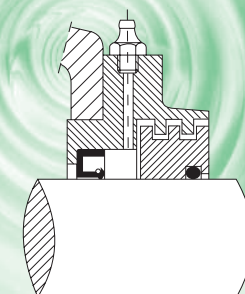

Chiusura di taconite "TAC" per: SN-SD  
"TAC" taconite cover for: SN-SD

Bull. fiss. Bolt Size	Dimensioni mm Dimensions mm				Peso Weight (Kg)	Cuscinetto orientabile a rulli (foro conico) Self-aligning roller bearing (conical bore)	Bussola (metrica) Adapter sleeve (metric)	Anello di centraggio Locating ring		Tipo Type
	d2 H12	d3 H12	f1 H13	f2				Tipo Type	Q.tà Q.ty	
M 30	153	183	10	13,8	62	23034 K	H 3034	SR 260x10	1	<b>SD 3034</b>
M 30	163	193	10	13,8	78	23036 K	H 3036	SR 280x10	1	<b>SD 3036</b>
M 30	173	203	10	13,8	82	23038 K	H 3038	SR 290x10	1	<b>SD 3038</b>
M 30	183	213	10	13,8	92	23040 K	H 3040	SR 310x10	1	<b>SD 3040</b>
M 30	203	240	11	15,7	125	23044 K	H 3044	SR 340x10	1	<b>SD 3044</b>
M 30	223	260	11	15,7	140	23048 K	H 3048	SR 360x10	1	<b>SD 3048</b>
M 36	243	286	12	17,4	200	23052 K	H 3052	SR 400x10	1	<b>SD 3052</b>
M 36	263	306	12	17,4	230	23056 K	H 3056	SR 420x10	1	<b>SD 3056</b>
M 36	283	332	13	19,1	290	23060 K	H 3060	SR 460x10	1	<b>SD 3060</b>
M 36	303	352	13	19,1	300	23064 K	H 3064	SR 480x10	1	<b>SD 3064</b>
M 42	323	372	13	19,1	400	23068 K	H 3068	SR 520x10	1	<b>SD 3068</b>
M 42	343	392	13	19,1	450	23072 K	H 3072	SR 540x10	1	<b>SD 3072</b>
M 42	363	412	13	19,1	470	23076 K	H 3076	SR 560x10	1	<b>SD 3076</b>

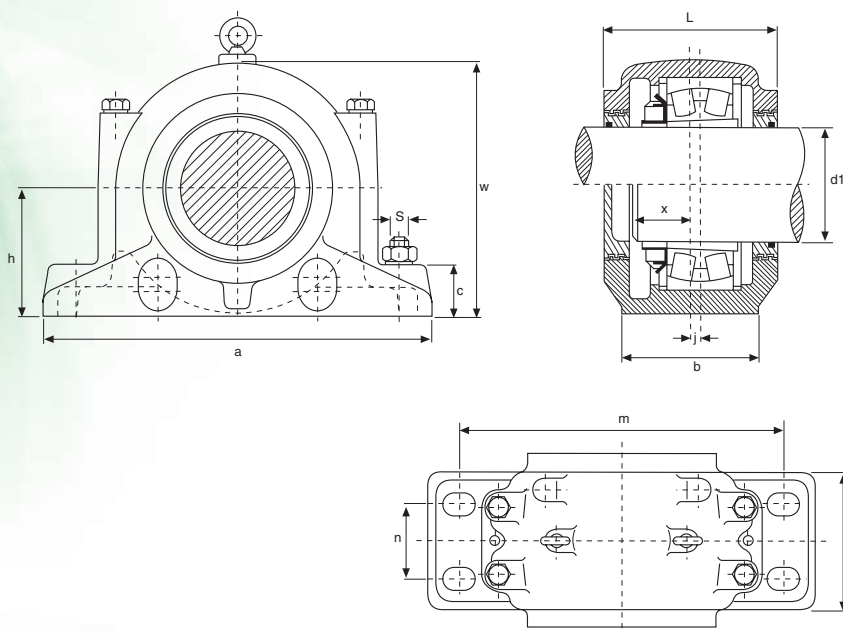

Tipo Type	Diametro albero d1 Shaft diameter d1		Dimensioni mm Dimensions mm										
	mm mm	pollici inch	D H8	a	b	c	g H12	h h12	L ± 5	L2	w	m	n
SD 3134	150	6	280	510	180	70	108	170	230	308	335	430	100
SD 3136	160	6½	300	530	190	75	116	180	240	318	355	450	110
SD 3138	170	6¾	320	560	210	80	124	190	260	336	375	480	120
SD 3140	180	7	340	610	230	85	132	210	280	356	410	510	130
SD 3144	200	-	370	640	240	90	140	220	290	368	435	540	140
SD 3148	220	-	400	700	260	95	148	240	310	388	475	600	150
SD 3152	240	-	440	770	280	100	164	260	320	400	515	650	160
SD 3156	260	-	460	790	280	105	166	280	320	400	550	670	160
SD 3160	280	-	500	830	310	110	180	300	350	426	590	710	190
SD 3164	300	-	540	880	330	115	196	320	370	448	630	750	200
SD 3168	320	-	580	965	380	120	210	340	390	488	670	840	240
SD 3172	340	-	600	1040	390	130	212	360	390	498	720	890	255
SD 3176	360	-	620	1120	400	135	214	380	405	520	750	980	255
SD 3180	380	-	650	1245	420	140	220	400	425	543	790	1050	270



**SD 3100**

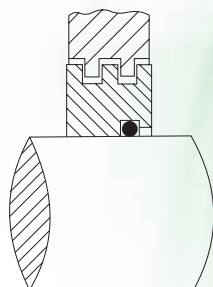
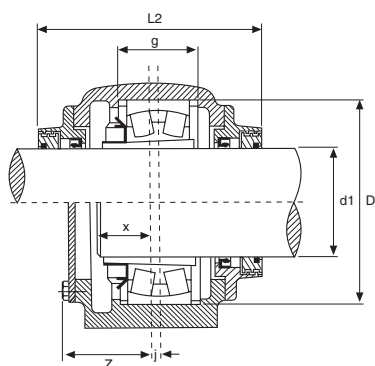

Tenuta a labirinto "TS" per: SN-SD  
"TS" labyrinth seal for: SN-SD

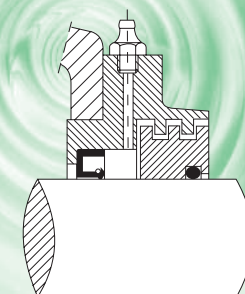

Chiusura di taconite "TAC" per: SN-SD  
"TAC" taconite cover for: SN-SD

Se non diversamente specificato viene fornito il supporto aperto di tipo "B"  
Unless specified "B" type open housing supplied

Dimensioni mm Dimensions mm			Bull. fiss. Bolt Size	Peso Weight (Kg)	Cuscinetto orientabile a due corone di rulli (foro conico) Double row spherical roller bearings (conical bore)	Bussola Adapter sleeve		Anello di centraggio Locating ring		"TS" Tenuta a labirinto Labyrinth seal	"TAC" Chiusura di taconite Taconite cover	Tipo Type
J	X	Z	S			mm mm	pollici inch	Tipo Type	Q.tà Q.ty			
14	65	120	M 24	70	23134 K	H 3134	HE 3134	SR 280x10	2	TS 3134	TAC 3134	SD 3134
15	68	130	M 24	72	23136 K	H 3136	HE 3136	SR 300x10	2	TS 3136	TAC 3136	SD 3136
10	80	140	M 24	88	23138 K	H 3138	HE 3138	SR 320x10	2	TS 3138	TAC 3138	SD 3138
10	82	150	M 30	122	23140 K	H 3140	HE 3140	SR 340x10	2	TS 3140	TAC 3140	SD 3140
12	90	155	M 30	136	23144 K	H 3144	-	SR 370x10	2	TS 3144	TAC 3144	SD 3144
12	100	160	M 30	190	23148 K	H 3148	-	SR 400x10	2	TS 3148	TAC 3148	SD 3148
13	105	170	M 36	238	23152 K	H 3152	-	SR 440x10	2	TS 3152	TAC 3152	SD 3152
16	105	170	M 36	252	23156 K	H 3156	-	SR 460x10	2	TS 3156	TAC 3156	SD 3156
22	110	190	M 36	290	23160 K	H 3160	-	SR 500x10	2	TS 3160	TAC 3160	SD 3160
23	120	200	M 36	340	23164 K	H 3164	-	SR 540x10	2	TS 3164	TAC 3164	SD 3164
25	135	220	M 45	430	23168 K	H 3168	-	SR 580x10	2	TS 3168	TAC 3168	SD 3168
22	145	225	M 50	560	23172 K	H 3172	-	SR 600x10	2	TS 3172	TAC 3172	SD 3172
22	145	240	M 55	770	23176 K	H 3176	-	SR 620x10	2	TS 3176	TAC 3176	SD 3176
22	150	260	M 60	870	23180 K	H 3180	-	SR 650x10	2	TS 3180	TAC 3180	SD 3180

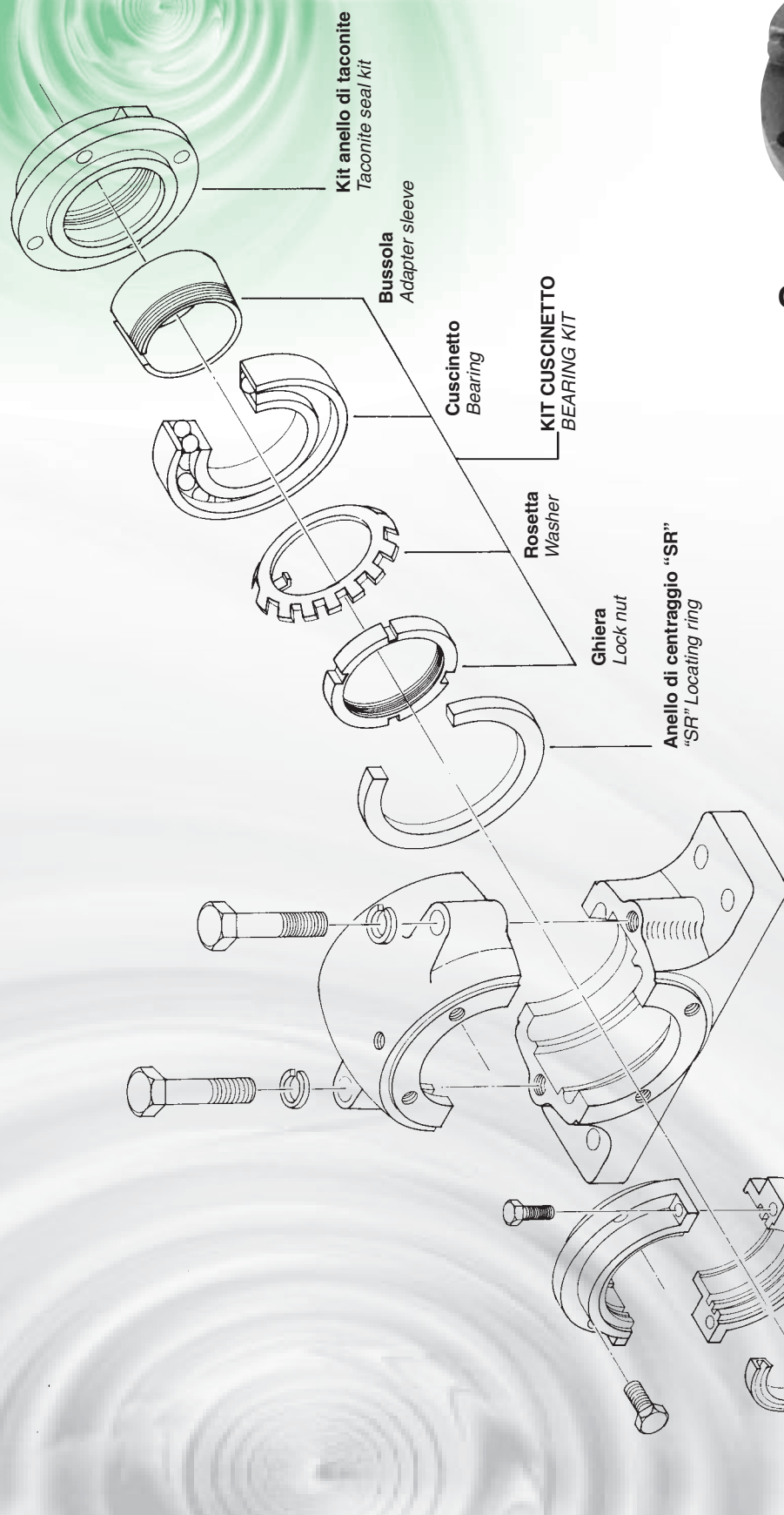

Kit anello di taconite  
Taconite seal kit

Bussola  
Adapter sleeve

Cuscinetto  
Bearing

Rosetta  
Washer

Ghiera  
Lock nut

Anello di centraggio "SR"  
"SR" Locating ring

Chiusura di taconite "TAC"  
"TAC" Taconite cover

Anello di tenuta  
Shaft seal

Tenuta a labirinto "TSNS"  
"TSNS" Labyrinth seal



**CHIUSURA DI TACONITE**  
**TACONITE COVER**

# KDF®



**Supporti in plastica**  
*Plastic bearing units*



La materia prima termoplastica di alto livello utilizzata dai costruttori KDF per realizzare i propri prodotti plastici, conferisce ai prodotti finali tutta una serie di proprietà che ne fanno prodotti di grande successo, molto ricercati nell'industria alimentare e chimica. Proprietà principali: elevata robustezza, attrito limitato, alta resistenza al logoramento e agli urti, alta resistenza chimica ed antiruggine.

### **Involucri termoplastici KDF**

Gli involucri portanti KDF sono costituiti da poliestere termoplastico di alta qualità, rinforzato con fibre di vetro PBT e sono totalmente intercambiabili con gli involucri convenzionali in ghisa. Questi involucri, che non richiedono alcuna manutenzione, presentano un'eccellente resistenza meccanica, rigidità e stabilità dimensionale; inoltre non arrugginiscono e non si corrodono mai.

### **Né placcature né rivestimenti che si scheggiano o si squamano**

Gli involucri in ghisa rivestita o placcata possono graffiarsi, scheggiarsi o squamarsi. Già la loro installazione provoca un'asportazione del rivestimento attorno agli spigoli dei bulloni necessari per il fissaggio. Visto che gli involucri KDF sono in PBT solido, per proteggerli non è necessario alcun tipo di rivestimento. Se anche dovessero prodursi delle graffiature o degli scheggiamenti, non si avrà mai l'esposizione di parti in ghisa vulnerabile.

### **Utilizzati in molte industrie**

Visto le loro proprietà antimagnetiche e di resistenza alla corrosione, gli involucri KDF vengono utilizzati in un'ampia gamma di industrie, tra cui quelle che si occupano di trasformazione alimentare, inscatolamento, imbottigliamento, trasformazioni chimiche e farmaceutiche, nonché in molte applicazioni industriali.

### **Gli involucri KDF durano a lungo**

Potete essere assolutamente sicuri che gli involucri plastici KDF resisteranno anche alle applicazioni più dure. La resistenza alla rottura (ASTM D 638) è di ben 17.300 psi. Gli involucri possono essere puliti o sciaquati con acqua bollente e sopportano temperature fino a 215°F (102°C). Tutti gli involucri sono provvisti di manicotti isolanti in acciaio inossidabile per il fissaggio dei bulloni e di ingrassatore in acciaio inossidabile.

The high grade thermoplastic raw material, from which KDF manufactures its plastic products endow the final products with a collection of properties which make them very successful and sought after products in the food and chemical industry. Main properties: high strength, low friction, high wear and shock resistance, high chemical resistance and antirust.

### **KDF Thermoplastic housings**

KDF bearing housings are made by KDF high-grade glass-filled thermoplastic polyester and they are completely interchangeable with conventional cast iron housings. These maintenance-free housings have excellent mechanical strength, stiffness and dimensional stability, yet they can never rust or corrode. Where high standards of cleanliness are important, such as in the food and food handling industries, their smooth surfaces are much more hygienic than those of cast iron housings whose rough surfaces can harbor objectionable dirt, mold or bacteria.

### **No plating or coating to chip or peel**

Coated or plated cast iron housings can scratch, chip and peel. In fact, the very act of installing them causes the finish to be removed around the edges of the bolts that hold them in place. Because KDF housings are solid PBT, coatings are not required to protect them. And even should they be scratched or chipped, there is no vulnerable cast iron that can be exposed.

### **Used in many industries**

Because of their corrosion-resistant and non-magnetic properties, KDF housings are used in a wide variety of industries, including: food processing, canning, bottling, pharmaceutical, chemical processing and in many general industrial applications.

### **KDF Housings are durable**

You can be completely confident that KDF plastic housings will stand out to the toughest applications. Tensile strength at break (ASTM D 638) is an impressive 17,300 psi. The housings can be cleaned or hosed down with hot water, and will operate at temperatures to 215°F (102°C). All housings include stainless steel sleeves for fixing bolts and stainless steel grease nipple.



Reparto produzione plastica / Plastic production department



Reparto produzione plastica / Plastic production department





## SUPPORTI RITTI IN PLASTICA PLASTIC PILLOW BLOCK UNITS

# KDF®

### UCP

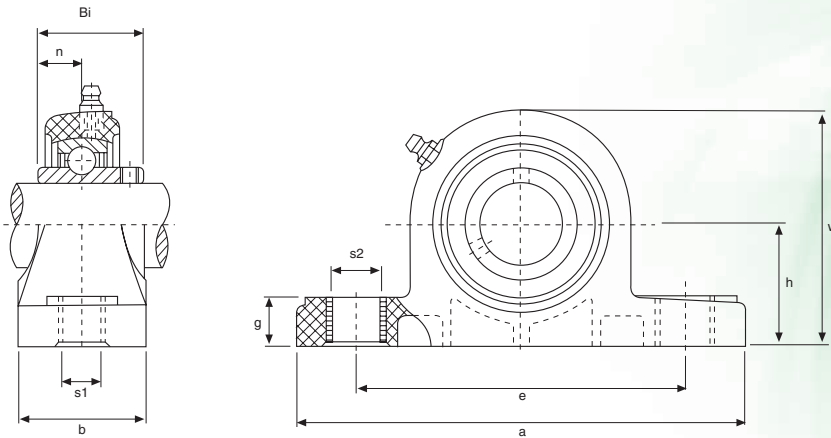

Tipo Type	Diametro albero Shaft diameter		Dimensioni mm Dimensions mm										Peso Weight (Kg)	Bull. fiss. Bolt Size	Coppia (Nm) Torque (Nm)
	mm mm	pollici inch	a	h	e	b	s1	s2	g	w	Bi	n			
UCP 201	12	1/2	127	33,3	95	38	11	14	14,2	65	31	12,7	0,12	M10	18
UCP 202	15	5/16 5/8	127	33,3	95	38	11	14	14,2	65	31	12,7	0,12	M10	18
UCP 203	17	11/16	127	33,3	95	38	11	14	14,2	65	31	12,7	0,12	M10	18
UCP 204	20	3/4	127	33,3	95	38	11	14	14,2	65,5	31	12,7	0,12	M10	18
UCP 205	25	1 3/16 7/8 1 5/16 1	140,5	36,5	105	38	11	14	14,5	71	34	14,3	0,14	M10	25
UCP 206	30	1 1/16 1 1/8 1 3/16 1 1/4	163	42,9	119	46	14	18	17,8	84	38,1	15,9	0,20	M12	30
UCP 207	35	1 1/4 1 5/16 1 3/8 1 7/16	168	47,6	127	48	14	18	18	94,5	42,9	17,5	0,25	M12	35
UCP 208	40	1 1/2 1 9/16	184	49,2	137	54	14	18	19,5	99	49,2	19	0,35	M12	45
UCP 209	45	1 5/8 1 11/16 1 3/4	192	54	146	54	17	20	23	106	49,2	19	0,45	M16	50
UCP 210	50	1 3/4 1 7/8 1 5/8 2	206	57,2	159	60	17	20	23	114	51,6	19	0,55	M16	55

Modalità di caricamento Mode of load	Coefficienti di carico (N) Load ratings (N)						
Tipo Type	204	205	206	207	208	209	210
	8 800	13 700	12 650	12 750	13 100	13 360	13 850
	7 700	10 000	10 600	10 800	11 100	11 400	11 750
	5 000	8 100	5 750	7 500	8 500	8 950	9 550

#### Caratteristiche

- Materiale: PBT (disponibili in color bianco, nero e verde)
- Intercambiabile con supporti in ghisa
- Ingrassatori zincati o d'acciaio
- Temperatura d'esercizio: da -35°C a +102°C
- Coperchio d'estremità
- Guarnizioni interne
- Resistenza chimica (pag. 96)

#### Characteristics

- Material: PBT (white, black and green colours available)
- Interchangeable with cast iron housing
- Galvanized or steel greasers
- Working temperature: from -35°C to +102°C
- End cover
- Back seals
- Chemical resistance (pag. 96)

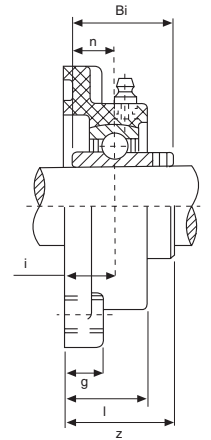
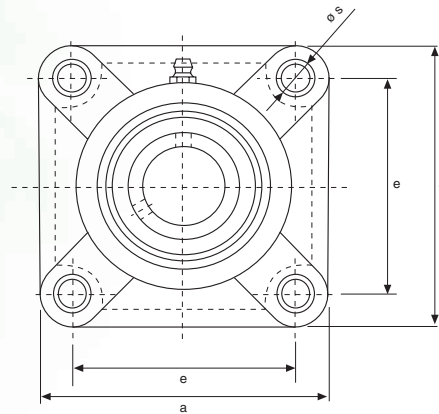

Tipo Type	Diametro albero Shaft diameter		Dimensioni mm Dimensions mm									Peso Weight (Kg)	Bull. fiss. Bolt Size	Coppia (Nm) Torque (Nm)
	mm mm	pollici inch	a	e	g	l	s	z	i	Bi	n			
UCF 201	12	1/2	86	63,5	13,4	27,8	11	36,3	18	31	12,7	0,12	M10	18
UCF 202	15	5/16 5/8	86	63,5	13,4	27,8	11	36,3	18	31	12,7	0,12	M10	18
UCF 203	17	11/16	86	63,5	13,4	27,8	11	36,3	18	31	12,7	0,12	M10	18
UCF 204	20	3/4	86	63,5	13,4	27,8	11	36,3	18	31	12,7	0,12	M10	18
UCF 205	25	1 3/16 7/8 1 5/16 1	95	70	14	28	11	36,7	17	34	14,3	0,15	M10	25
UCF 206	30	1 1/16 1 1/8 1 3/16 1 1/4	107	83	14,3	31,5	11	41,4	19,2	38,1	15,9	0,18	M10	30
UCF 207	35	1 1/4 1 5/16 1 3/8 1 7/16	118	92	15,5	34,8	13	46,9	21,5	42,9	17,5	0,26	M12	35
UCF 208	40	1 1/2 1 5/8	130	102	17	37,5	14	53,2	23	49,2	19	0,33	M12	40
UCF 209	45	1 5/8 1 11/16 1 3/4	137	105	19	41	17	54,2	24	49,2	19	0,42	M16	45
UCF 210	50	1 13/16 1 7/8 1 15/16 2	143	111	21	43	17	57,6	25	51,6	19	0,51	M16	50

Modalità di caricamento Mode of load	Coefficienti di carico (N) Load ratings (N)						
Tipo Type	204	205	206	207	208	209	210
	15 950	13 000	18 000	18 500	19 100	19 350	19 650
	10 250	12 150	17 700	18 500	19 250	19 350	19 620
	3 650	3 350	3 350	3 520	3 790	3 850	3 990

#### Caratteristiche

- Materiale: PBT (disponibili in color bianco, nero e verde)
- Intercambiabile con supporti in ghisa
- Ingrassatori zincati o d'acciaio
- Temperatura d'esercizio: da -35°C a +102°C
- Coperchio d'estremità
- Guarnizioni interne
- Resistenza chimica (pag. 96)

#### Characteristics

- Material: PBT (white, black and green colours available)
- Interchangeable with cast iron housing
- Galvanized or steel greasers
- Working temperature: from -35°C to +102°C
- End cover
- Back seals
- Chemical resistance (pag. 96)



## SUPPORTI A FLANGIA OVALE IN PLASTICA PLASTIC OVAL FLANGE UNITS

# KDF®

### UCFL

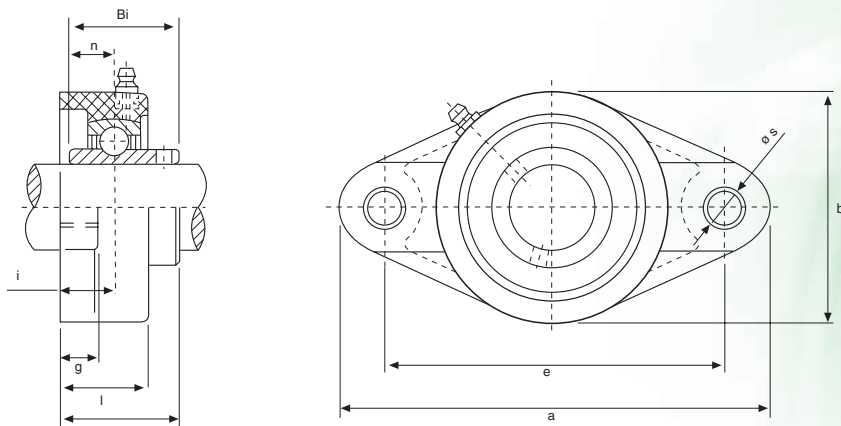

Tipo Type	Diametro albero Shaft diameter		Dimensioni mm Dimensions mm										Peso Weight (Kg)	Bull. fiss. Bolt Size	Coppia (Nm) Torque (Nm)
	mm mm	pollici inch	a	e	b	g	l	s	z	i	Bi	n			
UCFL 201	12	1/2	113	90	64	11,4	26,5	11	33,7	15,4	31	12,7	0,08	M10	18
UCFL 202	15	9/16 5/8	113	90	64	11,4	26,5	11	33,7	15,4	31	12,7	0,08	M10	18
UCFL 203	17	11/16	113	90	64	11,4	26,5	11	33,7	15,4	31	12,7	0,08	M10	18
UCFL 204	20	3/4	113	90	64	11,4	26,5	11	33,7	15,4	31	12,7	0,08	M10	18
UCFL 205	25	1 3/16 7/8 1 1/4 1	131	99	69,5	13,5	29,1	11	36,7	17	34	14,3	0,10	M10	25
UCFL 206	30	1 1/8 1 1/4 1 3/8 1 1/2	148	117	80	13,3	30,5	11	41,2	19	38,1	15,9	0,13	M10	30
UCFL 207	35	1 1/4 1 5/8 1 3/4 1 7/8	164	130	90	16,1	32,8	13	43,4	18	42,9	17,5	0,16	M12	35
UCFL 208	40	1 1/2 1 5/8	176	144	100	20	37,5	14	51,7	21,5	49,2	19	0,24	M12	40
UCFL 209	45	1 5/8 1 11/16 1 3/4	188	148	108	21	41	17	54,2	24	49,2	19	0,32	M16	45
UCFL 210	50	1 3/4 1 7/8 1 15/16 2	197	157	115	21	43	17	57,6	25	51,6	19	0,42	M16	50

Modalità di caricamento Mode of load	Coefficienti di carico (N) Load ratings (N)						
Tipo Type	204	205	206	207	208	209	210
	11 750	11 375	16 450	16 900	17 350	17 600	17 950
	11 000	13 850	13 350	13 950	14 050	14 300	14 550
	8 500	11 100	14 200	14 900	15 150	15 350	15 650

#### Caratteristiche

- Materiale: PBT (disponibili in color bianco, nero e verde)
- Intercambiabile con supporti in ghisa
- Ingrassatori zincati o d'acciaio
- Temperatura d'esercizio: da -35°C a +102°C
- Coperchio d'estremità
- Guarnizioni interne
- Resistenza chimica (pag. 96)

#### Characteristics

- Material: PBT (white, black and green colours available)
- Interchangeable with cast iron housing
- Galvanized or steel greasers
- Working temperature: from -35°C to +102°C
- End cover
- Back seals
- Chemical resistance (pag. 96)

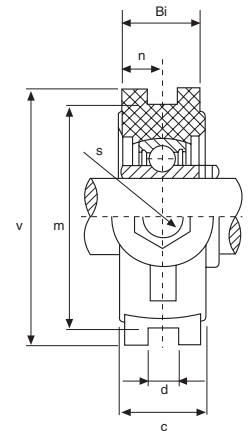
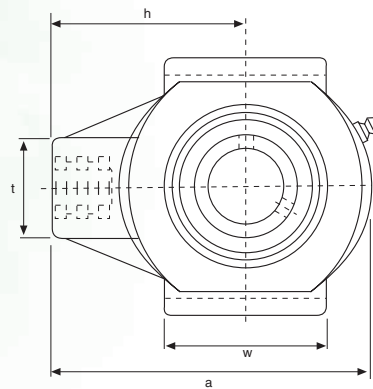

Tipo Type	Diametro albero Shaft diameter		Dimensioni mm Dimensions mm										Peso Weight (Kg)	Bull. fiss. Bolt Size  s
	mm mm	pollici inch	a	c	d	h	m	t	v	w	Bi	n		
UCT 201	12	1/2	99	27,5	12	64	76	35	88	47	31	12,7	0,16	M16
UCT 202	15	9/16 5/8	99	27,5	12	64	76	35	88	47	31	12,7	0,16	M16
UCT 203	17	11/16	99	27,5	12	64	76	35	88	47	31	12,7	0,16	M16
UCT 204	20	3/4	99	27,5	12	64	76	35	88	47	31	12,7	0,16	M16
UCT 205	25	1 3/16 7/8 1 1/4 1	99	27,5	12	64	76	35	88	47	34	14,3	0,17	M16
UCT 206	30	1 1/16 1 1/8 1 3/16 1 1/4	125	34,5	12	76	89	40	102	63	38,1	15,9	0,22	M16
UCT 207	35	1 1/4 1 5/16 1 3/8 1 7/16	125	34,5	12	76	89	40	102	63	42,9	17,5	0,26	M16
UCT 208	40	1 1/2 1 9/16	140	38,5	16	85	102	46	114	80	49,2	19	0,38	M16
UCT 209	45	1 5/8 1 11/16 1 3/4	149	40	16	90	102	50	117	85	49,2	19	0,48	M 20
UCT 210	50	1 13/16 1 7/8 1 15/16 2	149	40	16	90	102	50	117	85	51,6	19	0,52	M 20

Modalità di caricamento Mode of load	Coefficienti di carico (N) Load ratings (N)						
Tipo Type	204	205	206	207	208	209	210
	14 800	15 500	15 800	16 500	17 300	18 210	18 860
	3 930	4 530	5 100	6 500	7 800	8 710	9 750
	8 500	10 350	10 900	11 300	12 150	12 900	13550
	40 770	45 300	46 100	44 100	42 800	44 230	44 880

#### Caratteristiche

- Materiale: PBT (disponibili in color bianco, nero e verde)
- Intercambiabile con supporti in ghisa
- Ingrassatori zincati o d'acciaio
- Temperatura d'esercizio: da -35°C a +102°C
- Coperchio d'estremità
- Resistenza chimica (pag. 96)

#### Characteristics

- Material: PBT (white, black and green colours available)
- Interchangeable with cast iron housing
- Galvanized or steel greasers
- Working temperature: from -35°C to +102°C
- End cover
- Chemical resistance (pag. 96)



## SUPPORTI PENSILI IN PLASTICA PLASTIC HANGER BEARING UNITS

# KDF®

### UCECH

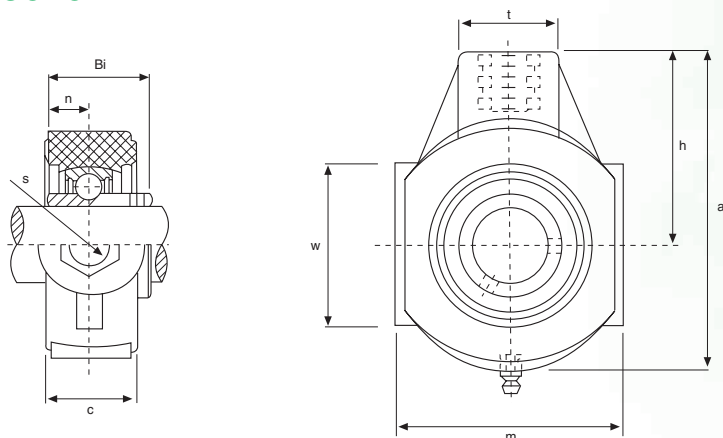

Tipo Type	Diametro albero Shaft diameter		Dimensioni mm Dimensions mm								Peso Weight (Kg)	Bull. fiss. Bolt Size s
	mm mm	pollici inch	a	c	h	m	t	w	Bi	n		
UCECH 201	12	1/2	99	27,5	63,5	65	35	47	31	12,7	0,15	M16
UCECH 202	15	9/16 5/8	99	27,5	63,5	65	35	47	31	12,7	0,15	M16
UCECH 203	17	11/16	99	27,5	63,5	65	35	47	31	12,7	0,15	M16
UCECH 204	20	3/4	99	27,5	63,5	65	35	47	31	12,7	0,15	M16
UCECH 205	25	13/16 7/8 15/16 1	99	27,5	63,5	74	35	47	34	14,3	0,16	M16
UCECH 206	30	1 1/16 1 1/8 1 3/16 1 1/4	125	34,5	76	90	40	63	38,1	15,9	0,21	M16
UCECH 207	35	1 1/4 1 5/16 1 3/8 1 7/16	125	34,5	76	90	40	63	42,9	17,5	0,25	M16
UCECH 208	40	1 1/2 1 5/8	140	38,5	85	100	46	80	49,2	19	0,36	M16
UCECH 209	45	1 5/8 1 11/16 1 3/4	149	40	90	110	50	85	49,2	19	0,45	M 20
UCECH 210	50	1 13/16 1 7/8 1 15/16 2	149	40	90	110	50	85	51,6	19	0,49	M 20

Modalità di caricamento Mode of load	Coefficienti di carico (N) Load ratings (N)							
	Tipo Type	204	205	206	207	208	209	210
		14 800	15 500	15 800	16 500	17 300	18 210	18 860
		3 930	4 530	5 100	6 500	7 800	8 710	9 750
		8 500	10 350	10 900	11 300	12 150	12 900	13550
		40 770	45 300	46 100	44 100	42 800	44 230	44 880

#### Caratteristiche

- Materiale: PBT (disponibili in color bianco, nero e verde)
- Intercambiabile con supporti in ghisa
- Ingrassatori zincati o d'acciaio
- Temperatura d'esercizio: da -35°C a +102°C
- Coperchio d'estremità
- Resistenza chimica (pag. 96)

#### Characteristics

- Material: PBT (white, black and green colours available)
- Interchangeable with cast iron housing
- Galvanized or steel greasers
- Working temperature: from -35°C to +102°C
- End cover
- Chemical resistance (pag. 96)

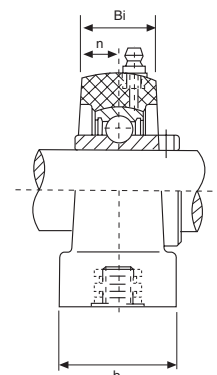
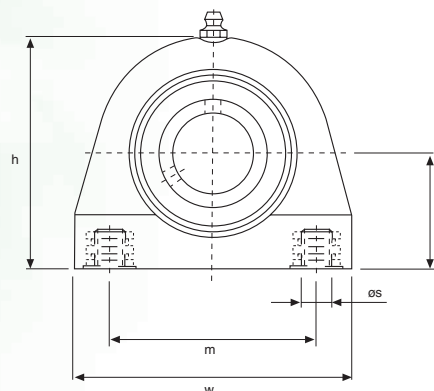
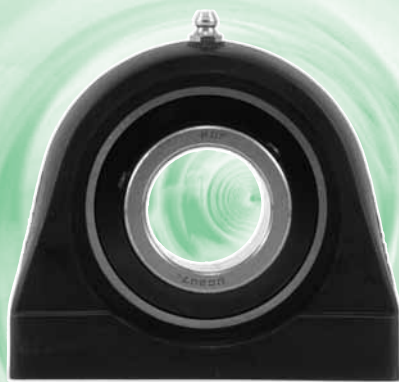

Tipo Type	Diametro albero Shaft diameter		Dimensioni mm Dimensions mm							Peso Weight (Kg)	Bull. fiss. Bolt Size s	Coppia (Nm) Torque (Nm)
	mm mm	pollici inch	a	b	h	m	w	Bi	n			
UCPA 201	12	1/2	33,3	34,5	66	50,8	72,8	31	12,7	0,13	M 8	18
UCPA 202	15	9/16 5/8	33,3	34,5	66	50,8	72,8	31	12,7	0,13	M 8	18
UCPA 203	17	11/16	33,3	34,5	66	50,8	72,8	31	12,7	0,13	M 8	18
UCPA 204	20	3/4	33,3	34,5	66	50,8	72,8	31	12,7	0,13	M 8	18
UCPA 205	25	1 3/16 7/8 1 1/4 1	36,5	39,5	73,5	50,8	76,2	34	14,3	0,15	M 10	25
UCPA 206	30	1 1/8 1 1/4 1 1/2 1 3/8	42,9	42,5	84	76,2	101	38,1	15,9	0,24	M 10	30
UCPA 207	35	1 1/4 1 5/16 1 3/8 1 7/16	47,6	47,5	95	82,6	110	42,9	17,5	0,28	M 10	35
UCPA 208	40	1 1/2 1 5/8	49,2	48	100,5	88,9	120	49,2	19	0,39	M 12	45
UCPA 209	45	1 5/8 1 11/16 1 3/4	54	54	107	95,3	124	49,2	19	0,47	M 12	50
UCPA 210	50	1 3/4 1 7/8 1 15/16 2	57,2	54	115	101,6	135	51,6	19	0,56	M 16	55

Modalità di caricamento Mode of load	Coefficienti di carico (N) Load ratings (N)						
Tipo Type	204	205	206	207	208	209	210
	8 210	8 540	10 370	12 150	12 230	12 900	13 850
	6 900	7 010	6 580	8 080	9 100	10 400	11 050
	2 980	2 850	4 950	8 160	9 800	10 710	11 360

#### Caratteristiche

- Materiale: PBT (disponibili in color bianco, nero e verde)
- Intercambiabile con supporti in ghisa
- Ingrassatori zincati o d'acciaio
- Temperatura d'esercizio: da -35°C a +102°C
- Coperchio d'estremità
- Resistenza chimica (pag. 96)

#### Characteristics

- Material: PBT (white, black and green colours available)
- Interchangeable with cast iron housing
- Galvanized or steel greasers
- Working temperature: from -35°C to +102°C
- End cover
- Chemical resistance (pag. 96)



## SUPPORTI A FLANGIA IN PLASTICA PLASTIC FLANGE BRACKET UNITS

# KDF®

### UCFB

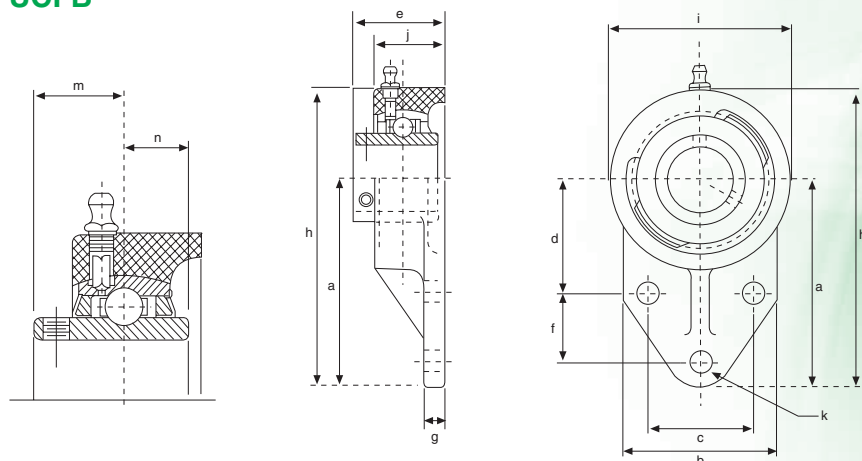

Tipo Type	Diametro albero Shaft diameter		Dimensioni mm Dimensions mm													Peso Weight (Kg)	Bull. fiss. Bolt Size	Coppia (Nm) Torque (Nm)
	mm mm	pollici inch	a	b	c	d	e	f	g	h	i	j	k	m	n			
UCFB 201	12	1/2	76,2	62	38,1	42,9	33,7	22,2	11,4	108	63,5	26,5	10,7	18,3	12,7	0,1	M 10	18
UCFB 202	15	9/16 5/8	76,2	62	38,1	42,9	33,7	22,2	11,4	108	63,5	26,5	10,7	18,3	12,7	0,1	M 10	18
UCFB 203	17	11/16	76,2	62	38,1	42,9	33,7	22,2	11,4	108	63,5	26,5	10,7	18,3	12,7	0,1	M 10	18
UCFB 204	20	3/4	76,2	62	38,1	42,9	33,7	22,2	11,4	108	63,5	26,5	10,7	18,3	12,7	0,1	M 10	18
UCFB 205	25	1 3/16 7/8 1 1/4 1	85,7	63,5	41,3	46	41,2	28,6	11,4	120,6	70	34	10,7	19,7	14,3	0,12	M 10	25
UCFB 206	30	1 1/16 1 1/8 1 3/16 1 1/4	95	76	47,6	52,4	41,5	31,8	13,3	138,5	83	32	10,7	22,2	15,9	0,16	M 10	30
UCFB 207	35	1 1/4 1 5/16 1 3/8 1 7/16	108	89	50,8	60,3	47,1	31,8	16,1	157	95	36,5	13,1	25,4	17,5	0,18	M 12	35

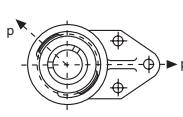
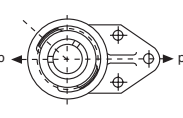
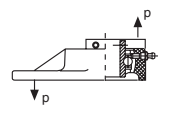
Modalità di caricamento Mode of load	Coefficients di carico (N) Load ratings (N)						
Tipo Type	201	202	203	204	205	206	207
	-	-	-	7 200	9 100	12 200	12 900
	-	-	-	9 200	11 100	11 800	11 900
	-	-	-	2 600	2 800	2 900	3 100

#### Caratteristiche

- Materiale: PBT (**disponibili in color bianco, nero e verde**)
- Intercambiabile con supporti in ghisa
- Ingrassatori zincati o d'acciaio
- Temperatura d'esercizio: da -35°C a +102°C
- Coperchio d'estremità
- Guarnizioni interne
- Resistenza chimica (pag. 96)

#### Characteristics

- Material: PBT (**white, black and green colours available**)
- Interchangeable with cast iron housing
- Galvanized or steel greasers
- Working temperature: from -35°C to +102°C
- End cover
- Back seals
- Chemical resistance (pag. 96)

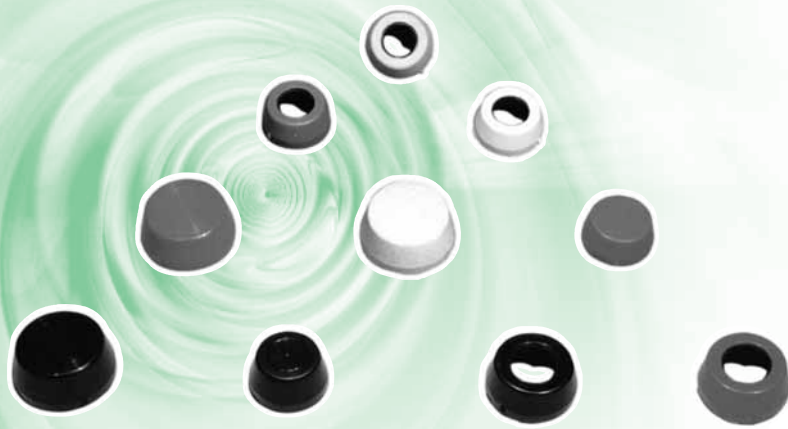

### Caratteristiche

- Materiale: Polipropilene (SR 50)
- Approvato FDA
- Coperchio aperto con anello in acciaio inox
- Gamma colori a richiesta

### Characteristics

- Material: Polypropylen (SR 50)
- FDA approved
- Open cover with stainless steel ring
- Range of colours on request

### COPERCHI IN PLASTICA CON GUARNIZIONI INTERNE PLASTIC COVERS WITH BACK SEALS

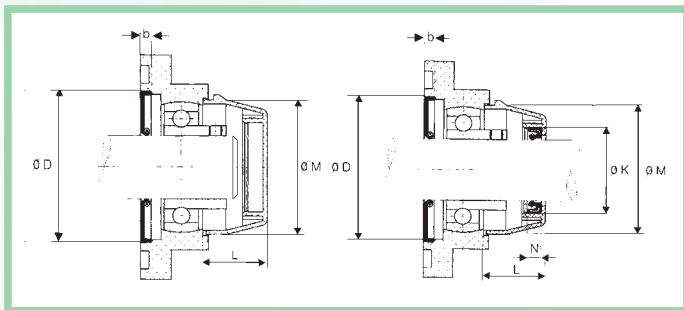

### COPERCHI IN PLASTICA FRONTALI CON GUARNIZIONI INTERNE FACE PLASTIC COVERS WITH BACK SEALS

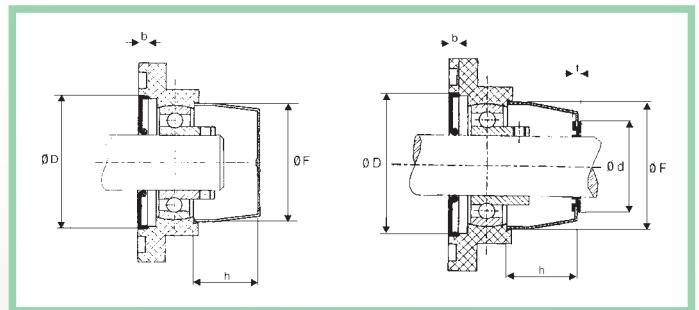

### COPERCHI INOX FRONTALI CON GUARNIZIONI INTERNE FACE INOX COVERS WITH BACK SEALS

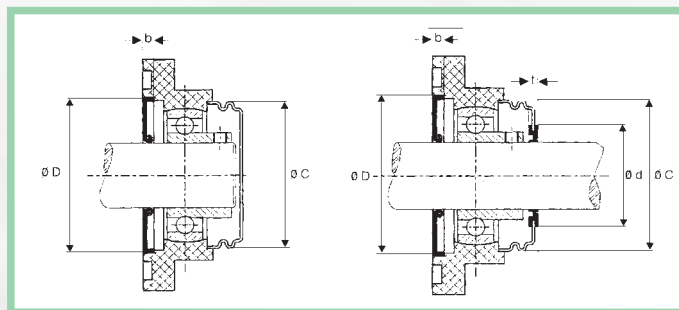

Diametro albero Shaft diameter		Dimensioni mm Dimensions mm										
mm mm	pollici inch	K	N	L	M	D	b	d	t	F	h	c
12	1/2	32	7	23	50	52	6	36	4	50	29,5	52
15	5/16 5/8	32	7	23	50	52	6	36	4	50	29,5	52
17	1 1/16	32	7	23	50	52	6	36	4	50	29,5	52
20	3/4	32	7	23	50	52	6	36	4	50	29,5	52
25	1 3/16 7/8 1 5/16 1	37	7	25	55	62	6	41	4	55	31	58
30	1 1/16 1 1/8 1 3/16 1 1/4	42	7	30	64	72	6	45	4	64	35	68
35	1 1/4 1 5/16 1 3/8 1 7/16	47	7	32	74,5	82	6	53	4	74	38	78
40	1 1/2 1 5/8	52	7	37	84	88	6	56	4	84	40	86





## CUSCINETTI A SFERE IN MATERIALI POLIMERICI POLYMERIC BALL BEARINGS

# KDF®

UC

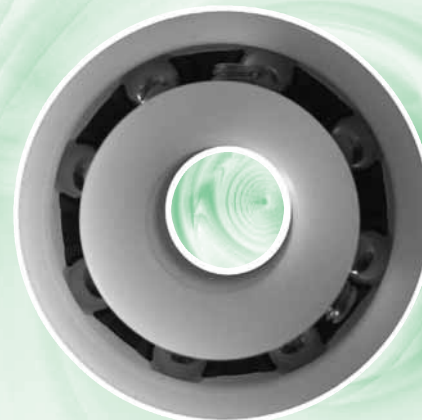
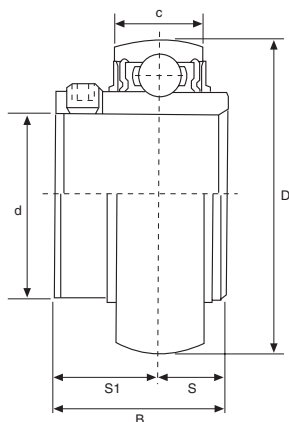

Tipo Type	Dimensioni mm/pollici Dimensions mm/inch						Carico Kg. cuscinetto Rating load bearing (daN) (Kp)		Numero di giri max./min. Speed max. r.p.m.	Peso Weight (Kg)
	d	D	B	C	S <sub>1</sub>	S	Dinamico Dynamic	Statico Static		
<b>UC 200</b>	10 -	47 1,8504	31 1,2205	17 0,6693	18,3 0,720	12,7 0,500	42	27	1 050	0,30
<b>UC 201</b> <b>UC201-8</b>	12 ¾	47 1,8504	31 1,2205	17 0,6693	18,3 0,720	12,7 0,500	42	27	1 050	0,30
<b>UC 202</b> <b>UC 202-9</b> <b>UC 202-10</b>	15 ⅝ ⅞	47 1,8504	31 1,2205	17 0,6693	18,3 0,720	12,7 0,500	42	27	1 050	0,30
<b>UC 203</b> <b>UC 203-11</b>	17 1⅛	47 1,8504	31 1,2205	17 0,6693	18,3 0,720	12,7 0,500	42	27	1 050	0,30
<b>UC 204</b> <b>UC 204-12</b>	20 ¾	47 1,8504	31 1,2205	17 0,6693	18,3 0,720	12,7 0,500	42	27	1 050	0,30
<b>UC 205</b> <b>UC 205-13</b> <b>UC 205-14</b> <b>UC 205-15</b> <b>UC 205-16</b>	25 1⅜ 7/8 1⅝ 1	52 2,0472	34,1 1,3425	17 0,6693	19,8 0,780	14,3 0,563	48	32	950	0,46
<b>UC 206</b> <b>UC 206-17</b> <b>UC 206-18</b> <b>UC 206-19</b> <b>UC 206-20</b>	30 1⅞ 1⅝ 1¾ 1¼	62 2,4409	38,1 1,5000	19 0,7480	22,2 0,874	15,9 0,626	55	36	800	0,69
<b>UC 207</b> <b>UC 207-20</b> <b>UC 207-21</b> <b>UC 207-22</b> <b>UC 207-23</b>	35 1¼ 1⅝ 1⅜ 1⅞	72 2,8346	42,9 1,6890	20 0,7874	25,4 1,000	17,5 0,689	62	41	700	0,89
<b>UC 208</b> <b>UC 208-24</b> <b>UC 208-25</b>	40 1½ 1⅞	80 3,1496	49,2 1,9370	22 0,8661	30,2 1,189	19 0,748	66	44	625	1,08

Disponibile anche:

**Cuscinetti a sfere in acciaio inox (AISI 440C)**

**Cuscinetti a sfere in acciaio (Cromo 100CR6 - SAE 52100)**

Per misure e carichi vedere a pagina 50

I cuscinetti sono di tipo aperto nella versione standard, sono anche disponibili con protezione singola e doppia. I valori riportati nella sopra indicata tabella si riferiscono a cuscinetti a sfere con anelli in resina acetica (POM).

Available also:

**Stainless steel bearings (AISI 440C)**

**Chrome steel bearings (Chrome 100CR6 - SAE 52100)**

For size and load see page 50

In standard version, the bearing are open, but can also be supplied in one or double shield version. The load capacities and speed limits stated in the table above, apply only to ball bearings with ring of polyacetal (POM).

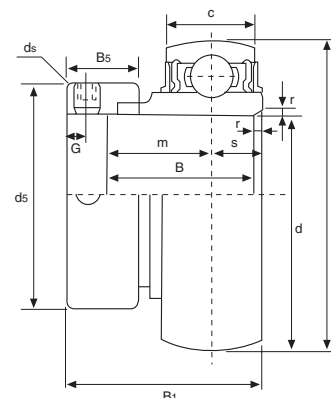

Suffisso UNF: Misure in pollici dei grani di bloccaggio  
UNF suffix: inch sized set screws

Tipo Type	Dimensioni mm/pollici Dimensions mm/inch												Carico Kg. cuscinetto Rating load bearing (daN) (Kp)		Peso Weight (Kg)
	d	c	D	B	r	s	m	B <sub>1</sub>	d <sub>s</sub>	B <sub>s</sub>	G	ds	Dinamico Dynamic	Statico Static	
<b>SA 204</b> <b>SA 204-12</b>	20 ¾	14 0,5512	47 1,8504	21,5 0,8465	1,5 0,0591	7 0,2756	14,5 0,5709	31 1,2205	33,3 1,3110	13,5 0,5315	5 0,1969	M6x0,75 -	60,6	37,8	0,10
<b>SA 205</b> <b>SA 205-13</b> <b>SA 205-14</b> <b>SA 205-15</b> <b>SA 205-16</b>	25 1 9/16 7/8 1 5/16 1	15 0,5906	52 2,0472	21,5 0,8465	1,5 0,0591	7,5 0,2953	14 0,5512	31 1,2205	38,1 1,5000	13,5 0,5315	5 0,1969	M6x0,75 -	66	42,6	0,11
<b>SA 206</b> <b>SA 206-17</b> <b>SA 206-18</b> <b>SA 206-19</b> <b>SA 206-20</b>	30 1 1/16 1 1/8 1 3/16 1 1/4	16 0,6299	62 2,4409	23,8 0,9370	1,5 0,0591	8 0,3150	15,8 0,6220	35,7 1,4055	44,5 1,7520	15,9 0,6260	6 0,2362	M8x1 5/16 24UNF	93	61,2	0,18
<b>SA 207</b> <b>SA 207-20</b> <b>SA 207-21</b> <b>SA 207-22</b> <b>SA 207-23</b>	35 1 1/4 1 3/8 1 7/8 1 7/8	17 0,6693	72 2,8346	25,4 1,000	2 0,0787	8,5 0,3346	16,9 0,6654	38,9 1,5315	55,6 2,1890	17,5 0,6890	6,5 0,2560	M8x1 5/16 24UNF	121,8	84	0,30
<b>SA 208</b> <b>SA 208-24</b> <b>SA 208-25</b>	40 1 1/2 1 5/8	19 0,7480	80 3,1496	30,2 1,1890	2 0,0787	9,5 0,3740	21,2 0,8346	43,7 1,7205	60,3 2,3740	18,3 0,7205	6,5 0,2560	M8x1 5/16 24UNF	138	96	0,38
<b>SA 209</b> <b>SA 209-26</b> <b>SA 209-27</b> <b>SA 209-28</b>	45 1 5/8 1 11/16 1 3/4	19 0,7480	85 3,3465	30,2 1,1890	2 0,0787	9,5 0,3740	20,7 0,8150	43,7 1,7205	63,5 2,5000	18,3 0,7205	6,5 0,2560	M8x1 5/16 24UNF	154,2	108,6	0,40
<b>SA 210</b> <b>SA 210-29</b> <b>SA 210-30</b> <b>SA 210-31</b> <b>SA 210-32</b>	50 1 13/16 1 7/8 1 15/16 2	20 0,7874	90 3,5433	30,2 1,1890	2 0,0787	10 0,3937	21,2 0,8346	43,7 1,7205	69,9 2,7520	18,3 0,7205	6,5 0,2560	M10x1,25 -	165,6	120,6	0,48

**SB**

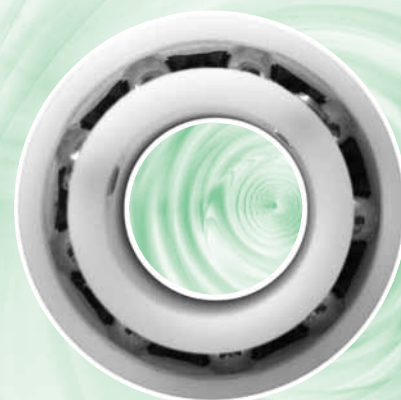
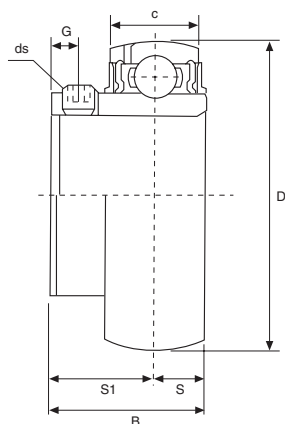

Suffisso UNF: Misure in pollici dei grani di bloccaggio  
UNF suffix: inch sized set screws

Tipo Type	Dimensioni mm/pollici Dimensions mm/inch								Carico Kg. cuscinetto Rating load bearing (daN) (Kp)		Peso Weight (Kg)
	d	c	D	B	s	S <sub>1</sub>	G	ds	Dinamico Dynamic	Statico Static	
<b>SB 204</b> SB 204-12	20 ¾	14 0,5512	47 1,8504	25 0,9843	7 0,2756	18 0,7087	4,5 0,1772	M6x0,75 -	60,6	37,8	0,08
<b>SB 205</b> SB 205-13 SB 205-14 SB 205-15 SB 205-16	25 13/16 7/8 15/16 1	15 0,5906	52 2,0472	27 1,0630	7,5 0,2953	19,5 0,7677	5 0,1969	M6x0,75 -	66	42,6	0,10
<b>SB 206</b> SB 206-17 SB 206-18 SB 206-19 SB 206-20	30 1 1/16 1 1/8 1 3/16 1 1/4	16 0,6299	62 2,4409	30 1,1811	8 0,3150	22 0,8661	5,5 0,2165	M6x0,75 -	93	61,2	0,15
<b>SB 207</b> SB 207-20 SB 207-21 SB 207-22 SB 207-23	35 1 1/4 1 5/16 1 3/8 1 7/16	17 0,6693	72 2,8346	32 1,2598	8,5 0,3346	23,5 0,9252	6 0,2362	M8x1 5/16 24UNF	121,8	84	0,22
<b>SB 208</b> SB 208-24 SB 208-25	40 1 1/2 1 9/16	19 0,7480	80 3,1496	34 1,3386	9,5 0,3740	25 0,9843	8 0,3150	M8x1 5/16 24UNF	138	96	0,27
<b>SB 209</b> SB 209-26 SB 209-27 SB 209-28	45 1 5/8 1 11/16 1 3/4	19 0,7480	85 3,3465	41,2 1,6220	10,2 0,4016	31 1,2205	8 0,3150	M8x1 5/16 24UNF	154,2	108,6	0,48
<b>SB 210</b> SB 210-29 SB 210-30 SB 210-31 SB 210-32	50 1 13/16 1 7/8 1 15/16 2	20 0,7874	90 3,5433	43,5 1,7126	10,9 0,4291	32,6 1,2835	9 0,3543	M10x1,25 -	165,6	120,6	0,52



### Proprietà tipiche del PBT Typical properties of PBT

Proprietà Propeties	Unità Unit	Metodo per il test Method test	Valori Value
<b>Meccaniche Mechanical</b>			
Resistenza alla trazione prima della deformazione prima della rottura	N/mm <sup>2</sup>	ASTM D 638	115
	N/mm <sup>2</sup>	ASTM D 638	-
Tensile strenght at yield at break	N/mm <sup>2</sup>	ASTM D 638	115
	N/mm <sup>2</sup>	ASTM D 638	-
Allungamento relativo prima della deformazione prima della rottura	%	ASTM D 638	3
	%	ASTM D 638	-
Elongation at yield at break	%	ASTM D 638	3
	%	ASTM D 638	-
Modulo elastico a trazione Tensile modulus	N/mm <sup>2</sup>	ASTM D 638	8000
	N/mm <sup>2</sup>	ASTM D 638	8000
Resistenza alla flessione prima della deformazione Flexural yield strenght	N/mm <sup>2</sup>	ASTM D 790	-
	N/mm <sup>2</sup>	ASTM D 790	-
Resistenza alla flessione prima della deformazione Flexural yield strenght	N/mm <sup>2</sup>	ASTM D 790	170
	N/mm <sup>2</sup>	ASTM D 790	170
Modulo di rigidità flessione Flexural modulus	N/mm <sup>2</sup>	ASTM D 790	7000
	N/mm <sup>2</sup>	ASTM D 790	7000
Resistenza all'impatto ad intaglio Charpy Notched impact strenght Charpy	K/m <sup>2</sup>	DIN 53453	12
	K/m <sup>2</sup>	DIN 53453	12
Resistenza all'impatto ad intaglio IZOD Notched impact strenght IZOD	N/mm <sup>2</sup>	ASTM D 256	100
	N/mm <sup>2</sup>	ASTM D 256	100
Durezza Hardness H358/10 H358/60 Rockwell	N/mm <sup>2</sup>	DIN 53456	140
	N/mm <sup>2</sup>	DIN 53456	101
	N/mm <sup>2</sup>	ASTM D 785	L102
	N/mm <sup>2</sup>	ASTM D 785	L102
<b>Termiche Thermal</b>			
Coefficiente di ossigeno Oxygen index	%	ASTM D 2863	19
	%	ASTM D 2863	19
Ritardamento di fiamma (1/6 mm spessore) Flame retardancy (1/6 mm trickness)	-	UL stand 94	94HB
	-	UL stand 94	94HB
Resistenza al calore: Vicat, Metodo B Heat resistance: Vicat, Method B	°C	ASTM D 1525	210-215
	°C	ASTM D 1525	210-215
Conduttività termica Thermal conductivity	W/m <sup>2</sup> C	ASTM C 177	0,19
	W/m <sup>2</sup> C	ASTM C 177	0,19
Flusso di contrazione dello stampo Modul shrinkage flow	%	ASTM D 1299	04-0,6
	%	ASTM D 1299	04-0,6
Direzione di flusso trasversale Cross flow direction	%	ASTM D 1299	0,6-0,8
	%	ASTM D 1299	0,6-0,8
<b>Fisiche Physical</b>			
Assorbimento dell'acqua Water absorption			
	%	ASTM D 570	0,06

### Resistenza chimica del PBT Chemical resistance of PBT

Mezzi chimici Chemical media	°C	% giorni immulsione % Immulsion days	% Forza di ritenzione % Strenght of ritention
<b>Acidi Acids</b>			
10% Cloridico 10% Hydrochloric	23	30	89
	23	90	85
	23	180	82
10% Solforico 10% Sulfuric	23	30	97
	23	90	94
	23	180	90
36% Solforico (batteria) 36% Sulfuric (battery)	23	30	89
	23	30	97
	23	180	96
	66	30	84
	66	180	35
10% Acetico 10% Acetic	23	30	89
	23	180	88
<b>Basi Bases</b>			
5% Idrossido di potassio 5% Potassium Hydroxide	23	30	83
	23	90	10
10% Idrossido di sodio 10% Sodium Hydroxide	23	30	2
	23	180	-
10% Idrossido di Ammonio 10% Ammonium Hydroxide	23	30	90
	23	90	87
	23	180	58
<b>Solventi organici Organic Solvents</b>			
Alcol etilico Ethyl Alcohol	23	30	99
	23	180	94
Alcol metilico Methyl Alcohol	23	30	91
	23	180	76
Alcol isopropilico Isopropyl-Alcohol	23	30	100
	23	180	100
Alcol isopropilico e acqua (50:50) Isopropyl-Alcohol & Water (50:50)	23	30	93
	23	180	96
Acquaragia Turpentine	23	180	92
	23	30	66
Acetone Acetonz	23	180	63
	23	30	90



**NOTE**  
*NOTES*

**KDF®**

---

---

---

---

---

---

---

---

---

---

---

---

---

---

---

---

---

---

---

---

---

---

---

---

---

---



The background of the page features a series of concentric circles. The top half has a green-to-white gradient, while the bottom half has a white-to-light grey gradient. The circles are centered and create a ripple effect across the entire page.

# KDF®

©Copyright **KDF®**

E' vietata la riproduzione anche parziale del contenuto di questo catalogo tecnico. Non si possono accettare responsabilità per eventuali errori od omissioni. Le misure non sono impegnative.

*The reproduction, even partial, of the contained concerning this technical catalogue, is forbidden. Liability for possible errors and/or omissions are not accepted. Sizes are not binding.*

# **KDF<sup>®</sup>**

**SUPPORTI AUTOALLINEANTI**  
***SELF-ALIGNING BEARING UNITS***



79991006