



Heavy Duty Type Cam Followers and Roller Followers

NUCF•NURT

CAT-5754A

*Cylindrical outer ring type is newly introduced in
Heavy Duty Type Roller Followers !*



Superior resistance against heavy loads and shock loads

Cam Followers · Roller Followers

Cylindrical outer ring type is newly introduced in Heavy Duty Type Roller Followers!

IKO
Heavy Duty Type
Cam Followers and Roller Followers
NUCF·NURT



IKO Heavy Duty Type Cam Followers and Roller Followers NUCF · NURT

Structure and Features

IKO Heavy Duty Cam Followers and Roller Followers are follower bearings designed for outer ring rotation, and feature superior resistance against heavy loads and/or shock loads, incorporating full complements of cylindrical rollers in two rows in a thick walled outer ring. Both Heavy Duty Type Cam Followers with a stud and Heavy Duty Type Roller Followers with an inner ring are available.

As cylindrical rollers are used, these follower bearings can withstand heavy radial loads as well as bi-directional axial loads.

They are designed for outer ring rotation, and both crowned and cylindrical outer rings are available. The outer rings run directly on mating track surfaces, and crowned outer rings can moderate the edge load caused by mounting errors. Cylindrical outer rings, on the other hand, have a large contact area with the mating track surface and are suitable for applications involving large loads or low track surface hardness.

Heavy Duty Type Cam Followers and Roller Followers are used in a wide range of applications such as cam mechanisms, support rollers for conveying equipment, pallet-changing mechanisms, etc.

Types

In Heavy Duty Type Cam Followers and Roller Followers, the following types are available.

Table 1 Types of Heavy Duty Type Cam Followers and Roller Followers

Type	Heavy Duty Type Cam Follower	Heavy Duty Type Roller Follower	
	Crowned outer ring	Crowned outer ring	Cylindrical outer ring
Model code	NUCF...R	NURT...R	NURT

Heavy Duty Type Cam Follower

In this type, shield plates are press-fitted into the outer ring, and narrow clearances are formed between a shield plate and a flange part of stud and between a shield plate and a side plate to serve as labyrinths.

A slotted groove for a screwdriver is prepared on the stud head for easy mounting. Oil holes are prepared in the stud, so that lubrication is also easy.

Heavy Duty Type Roller Follower

In this type, as an inner ring is incorporated instead of a stud of Cam Follower type, the mounting part can be designed freely. Heavy loads can be received by using a special shaft or yoke supported at both ends.

This follower will not separate, because shield plates are press-fitted into the outer ring.

Lubrication can be made through an oil hole prepared in the inner ring.

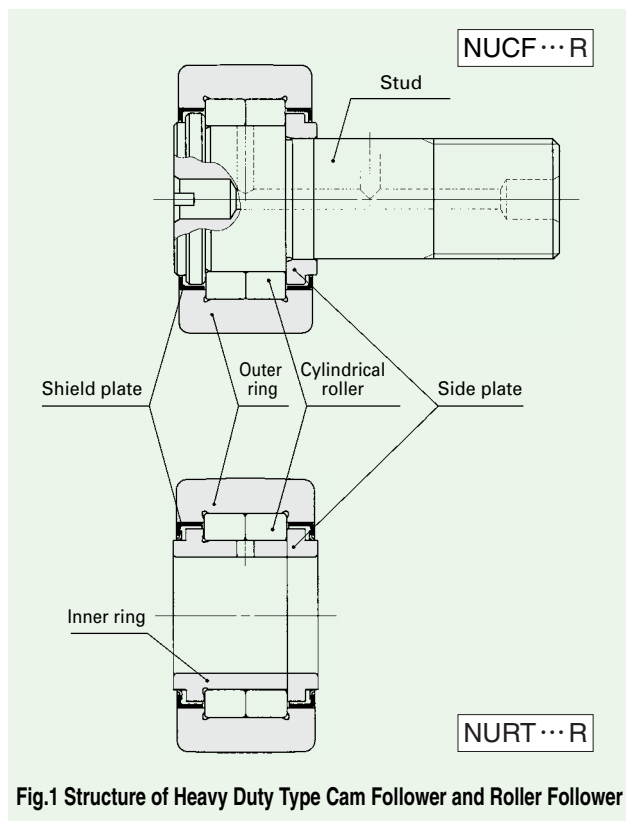
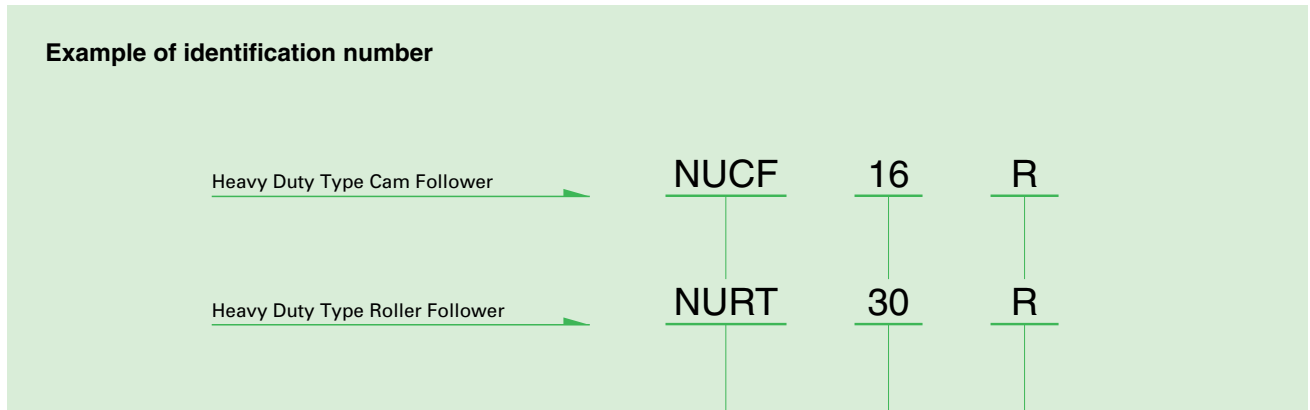

Fig.1 Structure of Heavy Duty Type Cam Follower and Roller Follower

Identification Number

Identification numbers of Heavy Duty Type Cam Followers and Roller Followers consist of a model code, a size and a supplemental code as shown below.



Model code	
NUCF	Heavy Duty Type Cam Followers
NURT	Heavy Duty Type Roller Followers

Size(unit:mm)	
NUCF	Size of stud dia.
NURT	Size of bore dia.

Supplemental code	
R	Crowned outer ring
No symbol	Cylindrical outer ring

Accuracy

Tolerances for Heavy Duty Type Cam Followers and Followers are shown in Tables 2.1, 2.2, 2.3 and 2.4. For special accuracy requirement, consult [IKKQ](#).

Table 2.1 Tolerances of Heavy Duty Type Cam Followers

unit: μm

Items		Tolerances
Outer ring outside dia.	D	0 - 50
Stud dia.	d_1	h7
Outer ring width	C	0 - 120

Table 2.2 Tolerances of Heavy Duty Type Roller Followers

unit: μm

Dimensions and symbols	Series	Metric series	
		Crowned outer ring	Cylindrical outer ring
Inner ring bore diameter	d	See Table 2.3.	
Outer ring outside diameter	D	0 - 50	See Table 2.4.
Outer ring width	C	0 - 120	
Inner ring width	B	0 - 120	
Overall width	B	h12	

Table 2.3 Tolerances of inner ring of Heavy Duty Type Roller Followers

unit: μm

d Nominal bore dia. mm		Δ_{dmp} Single plane mean bore dia. deviation		V_{dp} Bore dia. variation in a single radial plane (max.)	V_{dmp} Mean bore dia. variation in a single radial plane (max.)	K_{ia} Radial runout (max.)	V_{Bs} Variation of a single inner ring width (max.)
over	incl.	high	low				
10	18	0	- 8	10	6	10	20
18	30	0	- 10	13	8	13	20
30	50	0	- 12	15	9	15	20

Table 2.4 Tolerance of outer ring of Heavy Duty Type Roller Followers

unit: μm

D Nominal outside dia. mm		Δ_{Dmp} Single plane mean outside dia. deviation		V_{Dp} Outside dia. variation in a single radial plane (max.)	V_{Dmp} Mean outside dia. variation in a single radial plane (max.)	K_{ea} Radial runout (max.)	V_{Cs} Variation of a single outer ring width (max.)
over	incl.	high	low				
30	50	0	- 11	14	8	20	Same to the value of V_{Bs} for d of the same bearing
50	80	0	- 13	16	10	25	
80	120	0	- 15	19	11	35	

Clearance

Clearances of Heavy Duty Type Cam Followers and Roller Followers are shown in Tables 3.1 and 3.2.

Table 3.1 Clearance of Heavy Duty Type Cam Follower

unit: μm

Identification number	Radial internal clearance	
	Min	Max.
NUCF 10 R NUCF 10-1 R NUCF 12 R NUCF 12-1 R NUCF 16 R NUCF 18 R NUCF 20 R NUCF 20-1 R NUCF 24 R	20	45
NUCF 24-1 R NUCF 30 R NUCF 30-2 R	25	50

Table 3.2 Clearance of Heavy Duty Type Roller Follower

unit: μm

Identification number(1)	Radial internal clearance	
	Min	Max.
NURT 15 R NURT 15-1 R NURT 17 R NURT 17-1 R NURT 20 R NURT 20-1 R NURT 25 R NURT 25-1 R NURT 30 R NURT 30-1 R	20	45
NURT 35 R NURT 35-1 R NURT 40 R NURT 40-1 R	25	50
NURT 45 R NURT 45-1 R NURT 50 R NURT 50-1 R	30	60

Note(1): Also, applicable to cylindrical outer ring type.

Lubricant

Good quality lithium-soap base grease (Shell AV2) is pre-packed in Heavy Duty Type Cam Followers and Roller Followers. This grease can be used within a temperature range of -20C° to $+120\text{C}^{\circ}$

Oil hole

The position of oil hole of Heavy Duty Type Cam Follower is shown in Table 4. And the inner ring of Heavy Duty Type Roller Followers has one oil hole.

Table 4 Position of oil hole

○ : Oil hole is prepared.

Position of oil hole Stud dia. d_1 mm	① Stud head	② Stud outside surface	③ Stud end	
$d_1 \leq 10$	○	—	—	
$10 < d_1$	○	○	○	

Accessories

A grease nipple (Refer to Table 5.1.), a grease plug (Refer to Table 5.2.), and a screw nut are attached to Heavy Duty Type Cam Followers. Replenishment of grease is made by applying a straight type grease-gun as specified by JIS B 9809:1991 to the grease nipple from the front.

Table 5.1 Dimension of grease nipple

Code number	Dimensions of grease nipple mm						Applicable Cam Followers
	<i>d</i>	<i>D</i>	<i>D</i> ₁	<i>L</i>	<i>L</i> ₁	<i>W</i>	
NPT4	4	7.5	6	10	5.5	1.5	NUCF 10R ~ NUCF 10-1R
NPT6	6	8	6	11	6	2	NUCF 12R ~ NUCF 18 R
NPT8	8	10	6	16	7	3	NUCF 20R ~ NUCF 30-2R

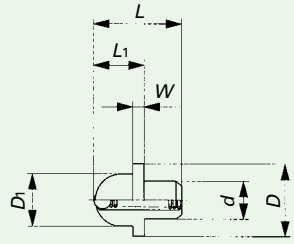
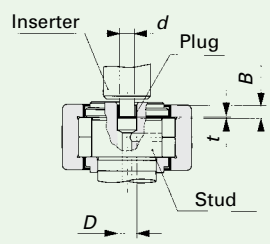

Table 5.2 Dimension of plug

Code number	Dimensions of plug mm			Insertor dimension mm	Applicable Cam Followers
	<i>D</i>	<i>t</i>	<i>B</i>	$d \begin{smallmatrix} 0 \\ -0.1 \end{smallmatrix}$	
UST4F	4	0.4	3.3	3	NUCF 10R ~ NUCF 10-1R
UST6F	6	0.4	4	5	NUCF 12R ~ NUCF 18 R
UST8F	8	0.4	5.8	7	NUCF 20R ~ NUCF 30-2R



Fit

The recommended tolerance of mounting hole for the stud of Heavy Duty Type Cam Follower is H7. Cam Followers are supported in a cantilever position. So, especially when heavy shock loads are applied, the mounting hole diameter should be prepared without play between the stud and the hole. The recommended tolerance of shaft assembled with an inner ring of Heavy Duty Type Roller Follower is g6 or h6.

Load Rating and Life

Basic dynamic load rating

The basic dynamic load rating is defined as a static radial load (in case of radial bearings), under which a rolling bearing achieves the basic rating life of 1 million revolutions.

Life

The basic rating life of Heavy Duty Type Cam Followers and Roller Followers is obtained from the following formula.

$$L_{10} = \left(\frac{C}{P}\right)^{10/3} \dots\dots\dots(1)$$

Where, L_{10} : Basic rating life, 10^6 rev.
 C : Basic dynamic load rating, N
 P : Dynamic equivalent load, N

If the number of revolutions per minute is known, the rating life in hours can be obtained from the following formula.

$$L_h = \frac{10^6 L_{10}}{60n} \dots\dots\dots(2)$$

Where, L_h : Basic rating life represented by service hours, h
 n : Rotational speed, rpm

Load factor

It is not unusual for actual bearing loads to exceed the calculated loads, due to vibration or shocks produced when operating the machine. The actual bearing load is obtained from the following equation, by multiplying the calculated load by the load factor.

$$F = f_w F_c \dots\dots\dots(3)$$

Where, F : Bearing load, N
 f_w : Load factor (See Table 6.)
 F_c : Theoretically calculated load, N

Table 6 Load factor

Operating conditions	f_w
Smooth operation without shocks	1 ~ 1.2
Ordinary operation	1.2 ~ 1.5
Operation subject to shock loads	1.5 ~ 3

Basic static load rating

The basic static load rating is defined as a static load which gives a prescribed contact stress at the center of contact area between rolling elements and raceways on which the maximum load is applied.

Maximum Allowable Load

The applicable load on the Heavy Duty Type Cam Followers and Roller Followers is, in some cases, limited by the bending strength and shear strength of stud or the strength of outer ring instead of the load rating of roller bearing. Maximum allowable loads are determined to give these limits.

Track Capacity

Track capacity is the allowable load for the steel-made mating track (flat surface) of Heavy Duty Type Cam Followers or Roller Followers, under which the track can be used continuously without deformation or dent marks. Track capacities shown in Tables 7.1 and 7.2 are the values in case that the hardness of the mating track is HRC40 (Tensile strength 1250N/mm²). If the hardness of the mating track is not HRC40, the track capacity is obtained by multiplying the value by a track capacity factor shown in Table 8.

If lubrication between the outer ring and the mating track is insufficient, seizure and/or wear may occur depending on the application. Therefore, it is needed to pay attention to lubrication and surface roughness of the mating track especially in case of high-speed operation such as cam mechanisms.

Table 7.1 Heavy Duty Type Cam Followers unit: N

Identification number	Track capacity
NUCF 10 R NUCF 10-1 R	1 610 2 030
NUCF 12 R NUCF 12-1 R	2 470 2 710
NUCF 16 R	3 060
NUCF 18 R	3 660
NUCF 20 R NUCF 20-1 R	5 190 4 530
NUCF 24 R NUCF 24-1 R	6 580 8 020
NUCF 30 R NUCF 30-2 R	9 220 10 800

Table 7.2 Heavy Duty Type Roller Followers unit: N

Crowned outer ring		Cylindrical outer ring	
Identification number	Track capacity	Identification number	Track capacity
NURT 15 R NURT 15-1 R	3 060 3 910	NURT 15 NURT 15-1	11 500 13 700
NURT 17 R NURT 17-1 R	3 660 4 530	NURT 17 NURT 17-1	13 600 16 000
NURT 20 R NURT 20-1 R	4 530 5 190	NURT 20 NURT 20-1	20 000 22 100
NURT 25 R NURT 25-1 R	5 190 6 580	NURT 25 NURT 25-1	22 100 26 400
NURT 30 R NURT 30-1 R	6 580 8 020	NURT 30 NURT 30-1	31 600 36 700
NURT 35 R NURT 35-1 R	8 020 9 220	NURT 35 NURT 35-1	36 700 40 800
NURT 40 R NURT 40-1 R	9 220 10 800	NURT 40 NURT 40-1	44 200 49 700
NURT 45 R NURT 45-1 R	9 990 12 400	NURT 45 NURT 45-1	47 000 55 300
NURT 50 R NURT 50-1 R	10 800 14 000	NURT 50 NURT 50-1	49 700 60 800

Table 8 Track capacity factor

Hardness HRC	Tensile strength N/mm ²	Track capacity factor	
		With crowned outer ring	With cylindrical outer ring
20	760	0.22	0.37
25	840	0.31	0.46
30	950	0.45	0.58
35	1 080	0.65	0.75
38	1 180	0.85	0.89
40	1 250	1.00	1.00
42	1 340	1.23	1.15
44	1 435	1.52	1.32
46	1 530	1.85	1.51
48	1 635	2.27	1.73
50	1 760	2.80	1.99
52	1 880	3.46	2.29
54	2 015	4.21	2.61
56	2 150	5.13	2.97
58	2 290	6.26	3.39

Allowable rotational speed

Allowable rotational speeds of Heavy Duty Type Cam Followers and Roller Followers are affected by mounting and operating conditions. The dn values for pure radial load operation are shown in Table 9, as a general guideline. Axial loads also act in an actual operation, so we recommend to use the values 1/10 of the dn values given in the table.

Table 9 dn value of Heavy Duty Type Cam Followers and Roller Followers

Bearing type	Lubrication	
	Grease	Oil
Heavy Heavy Duty Type Cam Followers and Roller Followers	66 000	110 000

Note: dn value = $d \times n$
 where, d : Stud diameter or bore dia. mm
 n : Number of rotations per minute, rpm

Mounting

Heavy Duty Type Cam Follower

- 1 Make the center axis of mounting hole perpendicular to the moving direction of the Cam Follower and match the side shoulder of the Cam Follower accurately with the seating surface indicated by dimension "f" in the dimension tables (Refer to Fig.2.). Then fix the Cam Follower with the nut. DO NOT hit the flange head of Cam Follower directly by a hammer, etc. It may lead to bearing failures such as irregular rotation and crack.

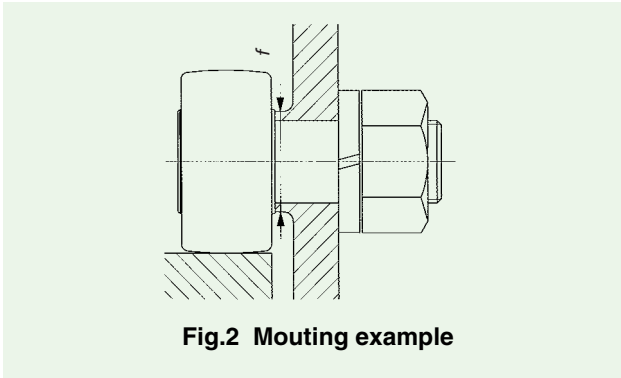



Fig.2 Mounting example

- 2 The  mark on the flange head of stud indicates the position of oil hole on the raceway. Avoid locating the oil hole within the loading zone. It may lead to short bearing life. (Refer to Fig.3.) The hole located in the middle part of the stud perpendicular to the stud center axis is used for greasing or locking the stud rotation.

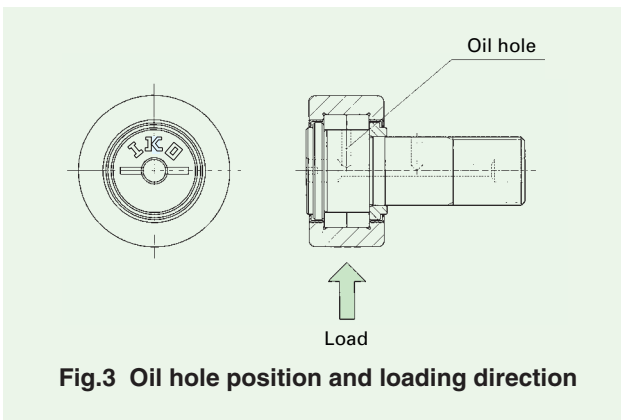

Fig.3 Oil hole position and loading direction

- 3 When tightening the nut, the tightening torque should not exceed the maximum tightening torque shown in the dimension tables. If the tightening torque is too large, it is possible that the threaded portion of stud will be broken. When there are possibilities of loosening, a special nut such as a lock nut, a spring washer or a self-locking nut should be used.

Heavy Duty Type Roller Followers

- 1 Fix the roller follower in an axial direction after fitting the side surface of the mounting part correctly to the flat shoulder "a" indicated in the dimension table (Refer to Fig.4.).
- 2 When the mounting this type, it is necessary to pay attention that the oil hole of inner ring should not be positioned within the loading zone. It may lead to short bearing life. (Refer to Fig.5.)

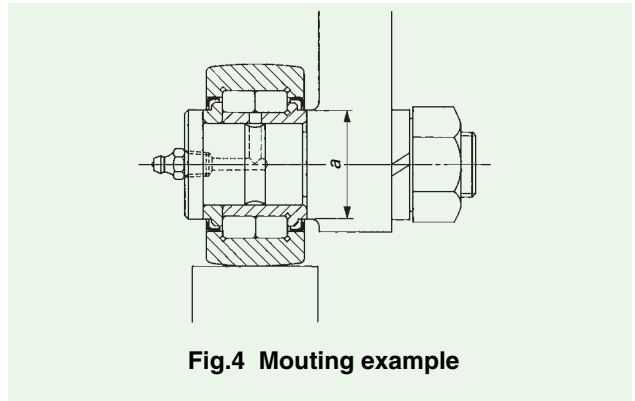

Fig.4 Mounting example

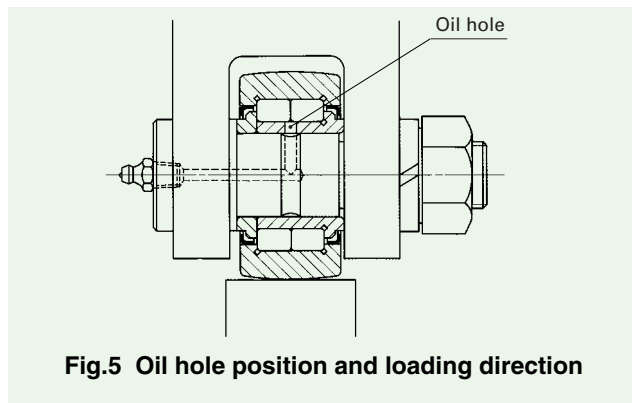
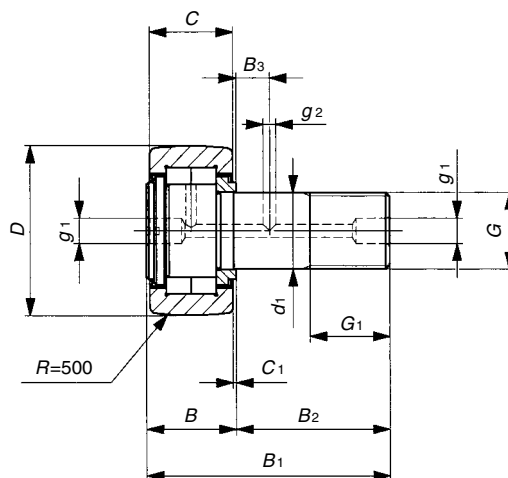
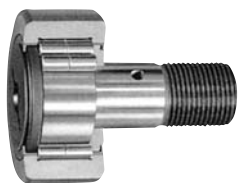

Fig.5 Oil hole position and loading direction

IKO Heavy Duty Type Cam Followers



NUCF...R

Stud dia. mm	Identification number	Mass (Ref.) g	Dimensions mm							
			D	C	d ₁	G	G ₁	B _{max}	B _{1 max}	B ₂
10	NUCF 10 R	44	22	12	10	M10 × 1.25	12	13.2	36.2	23
	NUCF 10-1 R	58	26	12	10	M10 × 1.25	12	13.2	36.2	23
12	NUCF 12 R	86	30	14	12	M12 × 1.5	13	15.2	40.2	25
	NUCF 12-1 R	97	32	14	12	M12 × 1.5	13	15.2	40.2	25
16	NUCF 16 R	167	35	18	16	M16 × 1.5	17	19.6	52.1	32.5
18	NUCF 18 R	244	40	20	18	M18 × 1.5	19	21.6	58.1	36.5
20	NUCF 20 R	457	52	24	20	M20 × 1.5	21	25.6	66.1	40.5
	NUCF 20-1 R	384	47	24	20	M20 × 1.5	21	25.6	66.1	40.5
24	NUCF 24 R	789	62	29	24	M24 × 1.5	25	30.6	80.1	49.5
	NUCF 24-1 R	1 020	72	29	24	M24 × 1.5	25	30.6	80.1	49.5
30	NUCF 30 R	1 600	80	35	30	M30 × 1.5	32	37	100	63
	NUCF 30-2 R	1 970	90	35	30	M30 × 1.5	32	37	100	63

Remark 1:NUCF10 R and NUCF10-1 R has only one oil hole (marked *)prepared in the stud flange head.
2:Good quality lithium soap base grease is pre-packed.

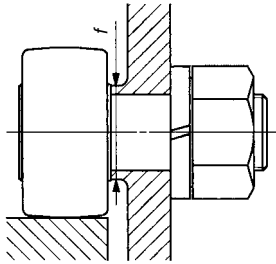

B_3	C_1	g_1	g_2	Mounting dimension f	Maximum tightening torque	Basic dynamic load rating C	Basic static load rating C_0	Maximum allowable load
				Min mm	N·m	N	N	N
—	0.6	*4	—	12	13.8	10 400	11 500	5 300
—	0.6	*4	—	12	13.8	10 400	11 500	9 210
6	0.6	6	3	17	21.9	14 000	13 400	5 650
6	0.6	6	3	17	21.9	14 000	13 400	9 040
8	0.8	6	3	20	58.5	23 400	27 300	11 800
8	0.8	6	3	22	86.2	25 200	30 900	20 300
9	0.8	8	4	31	119	43 100	58 100	30 000
9	0.8	8	4	27	119	38 900	49 000	27 200
11	0.8	8	4	38	215	58 200	75 300	35 200
11	0.8	8	4	44	215	63 900	88 800	57 000
15	1	8	4	45	438	90 300	121 000	98 300
15	1	8	4	45	438	90 300	121 000	98 300

IKO Heavy Duty Type Roller Followers

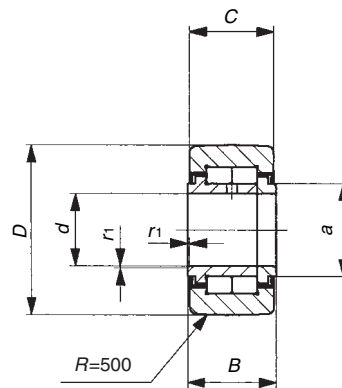

NURT...R

Shaft dia mm	Identification number		Mass (Ref.) g	Dimensions mm						
	Crowned outer ring	Cylindrical outer ring		d	D	B	C	a	r_s min ⁽¹⁾	r_{1s} min ⁽¹⁾
15	NURT 15 R	NURT 15	100	15	35	19	18	20	0.6	0.3
	NURT 15-1 R	NURT 15-1	160	15	42	19	18	20	0.6	0.3
17	NURT 17 R	NURT 17	147	17	40	21	20	22	1	0.3
	NURT 17-1 R	NURT 17-1	222	17	47	21	20	22	1	0.3
20	NURT 20 R	NURT 20	245	20	47	25	24	27	1	0.3
	NURT 20-1 R	NURT 20-1	321	20	52	25	24	27	1	0.3
25	NURT 25 R	NURT 25	281	25	52	25	24	31	1	0.3
	NURT 25-1 R	NURT 25-1	450	25	62	25	24	31	1	0.3
30	NURT 30 R	NURT 30	466	30	62	29	28	38	1	0.3
	NURT 30-1 R	NURT 30-1	697	30	72	29	28	38	1	0.3
35	NURT 35 R	NURT 35	630	35	72	29	28	44	1	0.6
	NURT 35-1 R	NURT 35-1	840	35	80	29	28	44	1	0.6
40	NURT 40 R	NURT 40	817	40	80	32	30	49	1	0.6
	NURT 40-1 R	NURT 40-1	1 130	40	90	32	30	49	1	0.6
45	NURT 45 R	NURT 45	883	45	85	32	30	53	1	0.6
	NURT 45-1 R	NURT 45-1	1 400	45	100	32	30	53	1	0.6
50	NURT 50 R	NURT 50	950	50	90	32	30	58	1	0.6
	NURT 50-1 R	NURT 50-1	1 690	50	110	32	30	58	1	0.6

Note⁽¹⁾: r_s min or r_{1s} min stands for the minimum allowable value of chamfer r or r_1 .

Remark 1. An oil hole is prepared in the inner ring.

2. Good quality lithium soap base grease is pre-packed.

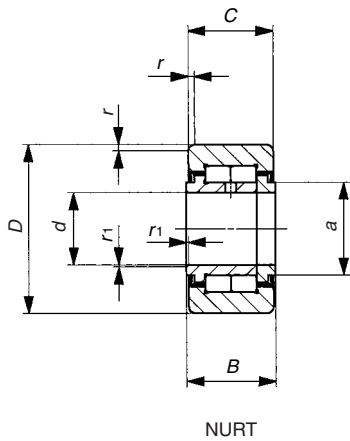

Basic dynamic load rating <i>C</i>	Basic static load rating <i>C₀</i>	Maximum allowable load
N	N	N
23 400	27 300	11 800
23 400	27 300	27 300
25 200	30 900	20 300
25 200	30 900	30 900
38 900	49 000	27 200
38 900	49 000	49 000
43 100	58 100	30 000
43 100	58 100	58 100
58 200	75 300	35 200
58 200	75 300	75 300
63 900	88 800	57 000
63 900	88 800	88 800
86 500	122 000	75 300
86 500	122 000	122 000
91 500	135 000	78 700
91 500	135 000	135 000
96 300	148 000	82 100
96 300	148 000	148 000



NIPPON THOMPSON CO., LTD.

Head office : 19-19 Takanawa 2-chome
Minato-ku, Tokyo 108-8586, Japan
Phone : Tokyo (03)3448-5850
Fax : (03)3447-7637
E-mail : ntt@ikonet.co.jp
URL : <http://www.ikont.co.jp/>
Plant : Gifu, Kamakura

IKO International, Inc.

- P.O. BOX 5897
91 Walsh Drive
Parsippany, NJ 07054
U.S.A.
Phone: (973)402-0254
Toll Free: 1-800-922-0337
Fax: (973)402-0441
E-mail: eco@ikonet.co.jp
- 500 East Thorndale Avenue
Wood Dale, IL 60191
U.S.A.
Phone: (630)766-6464
Toll Free: 1-800-323-6694
Fax: (630)766-6869
E-mail: mwo@ikonet.co.jp
- 20170 South Western Avenue
Torrance, CA 90501
U.S.A.
Phone: (310)609-3988
Toll Free: 1-800-252-3665
Fax: (310)609-3916
E-mail: wco@ikonet.co.jp
- 2150 Boggs Road, Suite 100
Duluth, GA 30096
U.S.A.
Phone: (770)418-1904
Toll Free: 1-800-874-6445
Fax: (770)418-9403
E-mail: seo@ikonet.co.jp
- 8105 N. Beltline Road
Suite 130, Irving, TX 75063
U.S.A.
Phone: (972)929-1515
Toll Free: 1-800-295-7886
Fax: (972)915-0060
E-mail: sw@ikonet.co.jp

Nippon Thompson Europe B.V.

- Sheffieldstraat 35-39
3047 AN Rotterdam
The Netherlands
Phone: 010-4626868
Fax: 010-4626099
E-mail: nte@ikonet.co.jp
- Mündelheimer Weg 56
40472 Düsseldorf
Germany
Phone: 0211-414061
Fax: 0211-427693
E-mail: ntd@ikonet.co.jp

Donaustauer Str. 200
93059 Regensburg
Germany
Phone: 0941-447737
Fax: 0941-447747
- 2 Vincent Avenue, Crownhill
Milton Keynes Bucks MK8 OAB
United Kingdom
Phone: 01908-566144
Fax: 01908-565458
E-mail: ntu@ikonet.co.jp
- Autovia Madrid-Barcelona, Km. 43,700
Polig. Ind. AIDA, A-8, Ofic. 2, 1^a
19200-Azuqueca de Henares
Guadalajara, Spain
Phone: 949-263390
Fax: 949-263113
E-mail: nts@ikonet.co.jp
- Roissypole Le Dôme
2 rue de La Haye
BP 10950 Tremblay en France
95733 Roissy C. D. G. Cedex
France
Phone: 01-48165739
Fax: 01-48165746
E-mail: ntf@ikonet.co.jp

Although all data in this catalog has been carefully compiled to make the information as complete as possible, NIPPON THOMPSON CO., LTD. shall not be liable for any damages whatsoever, direct or indirect, based upon any information in this catalog. NIPPON THOMPSON CO., LTD. makes no warranty, either express or implied, including the implied warranty of merchantability or fitness for a particular purpose.