

# IKO

## Maintenance Free C-Sleeve Linear Way

See you again at  
**IKO** Website  
<http://www.ikont.co.jp/eg/>

ML  
ME  
MH  
MUL

*Maintenance free for  
20,000 km or 5 years*



# IKO

## Maintenance Free & Interchangeable C-Sleeve Linear Way

IKO strives to be a leader in Technology. Our primary source for development is listening to the customer wants and needs. Our performance and work separate us from others by utilizing our creative thinking and original technologies. IKO is constantly developing and implementing new and advanced technologies in pursuit of excellent motion performance and service for your cost savings.



MINIMIZING  
LUBRICATION  
IKO EVOLVING TECHNOLOGY



# IKO Maintenance Free C-Sleeve Linear Way

# Maintenance free for 20,000 km or 5 years!!

Aquamarine end plate for identification of C-Sleeve Linear Way series

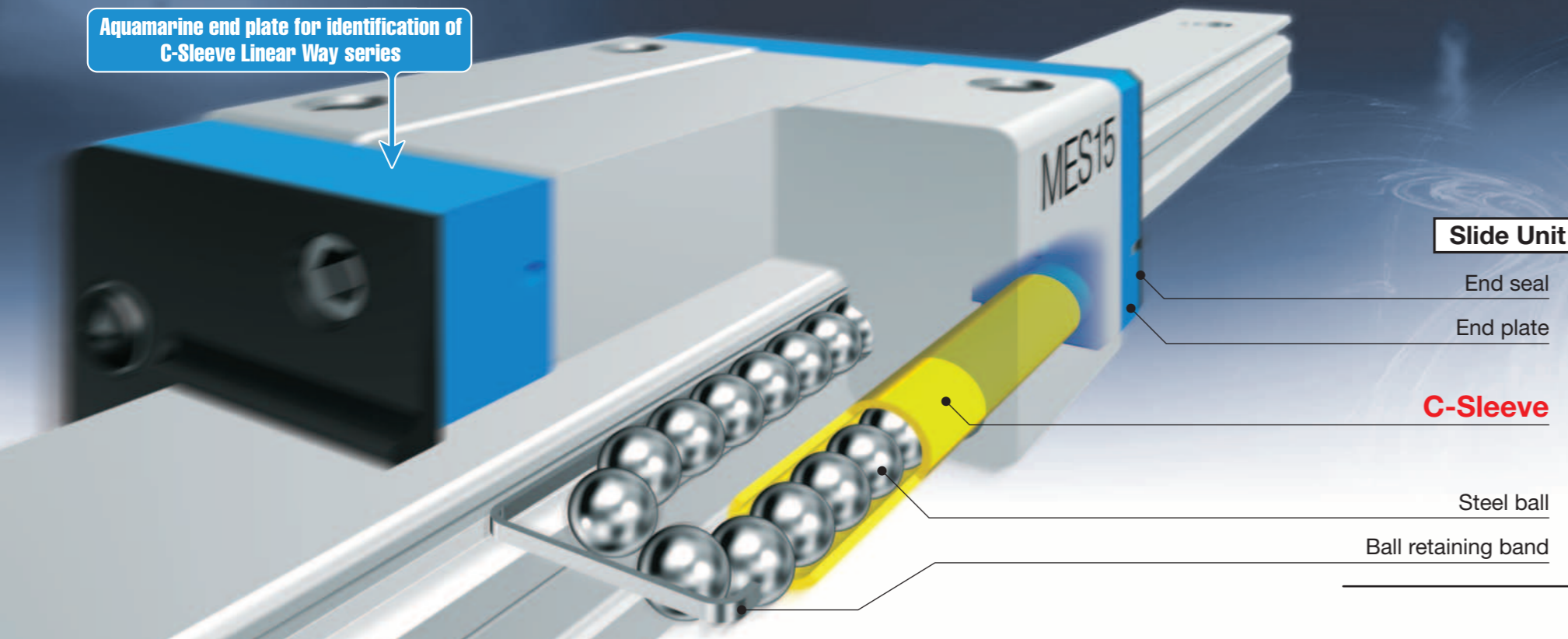

*Interchangeable spec.  
is available.*



C-Sleeve slide units can be supplied separately, and can be matched, replaced and added freely to the interchangeable track rail. This series will be useful in machine design, facilitating standardization of product specification and a quick change of specification.

Capillary system **IKO** has developed is an innovational lubrication system. It is a porous resin sleeve with steel backing formed by sintering fine resin powder and impregnating a large amount of lubrication oil in its open pores. Capillary system always supplies proper amount of lubrication oil to the balls and lubrication condition of the raceway can be kept well for long period of time.

Track Rail

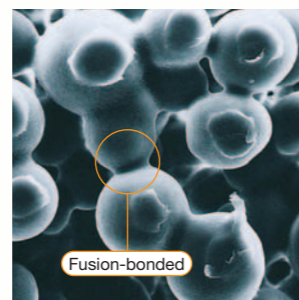

**Before impregnating oil**  
Resin particles are strongly fusion-bonded.

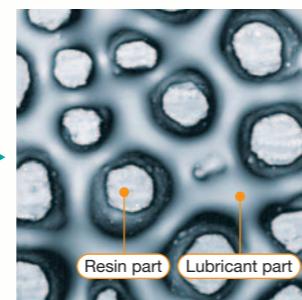

**After impregnating oil**  
(Capillary lubrication structure)  
Lubricant is retained in cavities amongst resin particles.

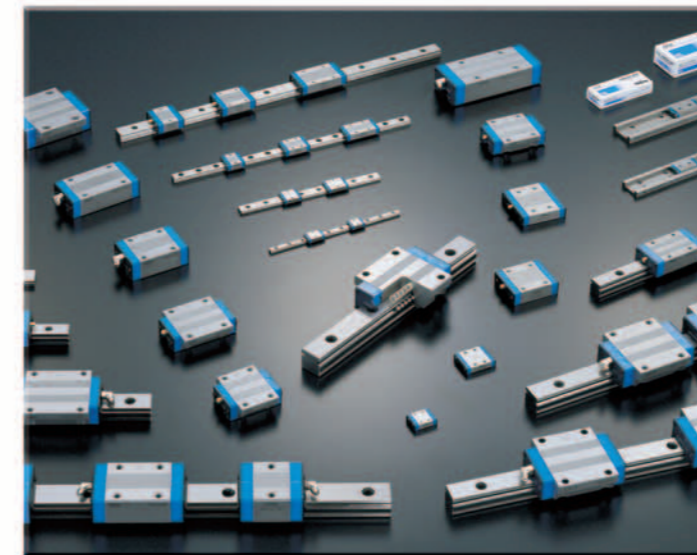

U.S. PATENTED

**C-Sleeve Linear Way ML**

No. 6729761  
6712511  
5435649  
5289779  
5250126  
4652147  
4505522

**C-Sleeve Linear Way ME**

No. 6729761  
6712511  
5564188  
5374126  
5356223  
5324116  
4652147  
4505522

**C-Sleeve Linear Way MH**

No. 6729761  
6712511  
5622433  
5564188  
5374126  
4652147  
4610488  
4505522

**C-Sleeve Linear Way MUL**

No. 6729761  
6712511  
6309107  
5435649  
5289779  
5250126  
4652147  
4505522



# Features of C-Sleeve Linear Way 1 ~Four technical advantages~

## Maintenance free for saving-resources

Maintenance free has the ability to maintain lubrication for a long time, reducing the amount of labor required for troublesome lubrication maintenance. The capillary lubrication body continuously supply lubricant for long period of time even after original grease inside is completely exhausted.

※ This durability test has been simulated for general machine purpose. Re-lubrication is necessary if operating condition is extremely severe.

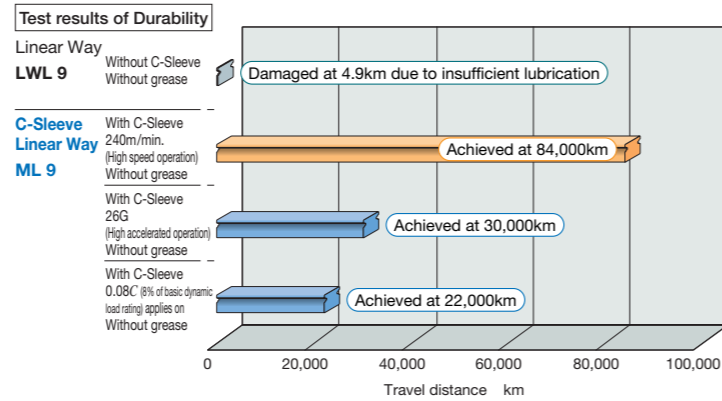

## Ecology contributes to the global environment by conserving oil

To accomplish this proposition, C-Sleeve applies only the minimal amount of lubricant required to properly lubricate the rolling parts. Since the oil consumption is small, C-Sleeve is able to maintain proper lubrication even in long-term operation.

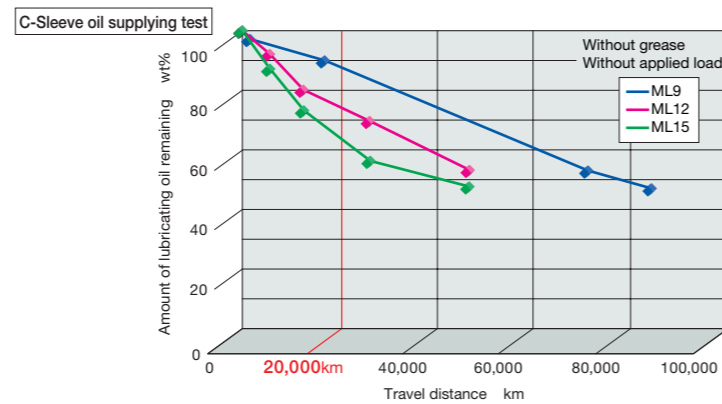

## Compact design for miniaturization

Incorporating C-Sleeve inside of the Linear Way provides a lightweight and compact size. C-Sleeve Linear Way having no external parts can be replaced by standard Linear Way without changing the external dimensions and it does not sacrifice the allowable stroke length.

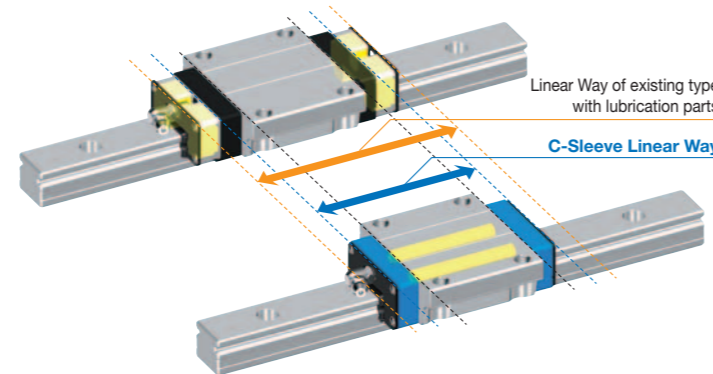

## Smooth and light operation

C-Sleeve is not in contact with the track rail. This permits smooth and light sliding motion without increasing the rolling resistance. The power loss of a driving device can be minimized. Compatibility of quick response is superior and it contributes accuracy improvement and saving drive energy.

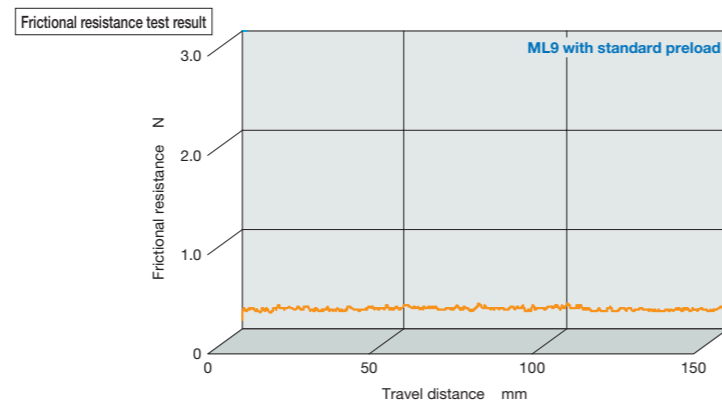

## Maintenance Free

Effectiveness of lubrication is maintained for long term, the cost of lubrication management and systems can be reduced.

## Ecology

C-Sleeve contributes to global environment protection because the amount of lubricant can be minimized.

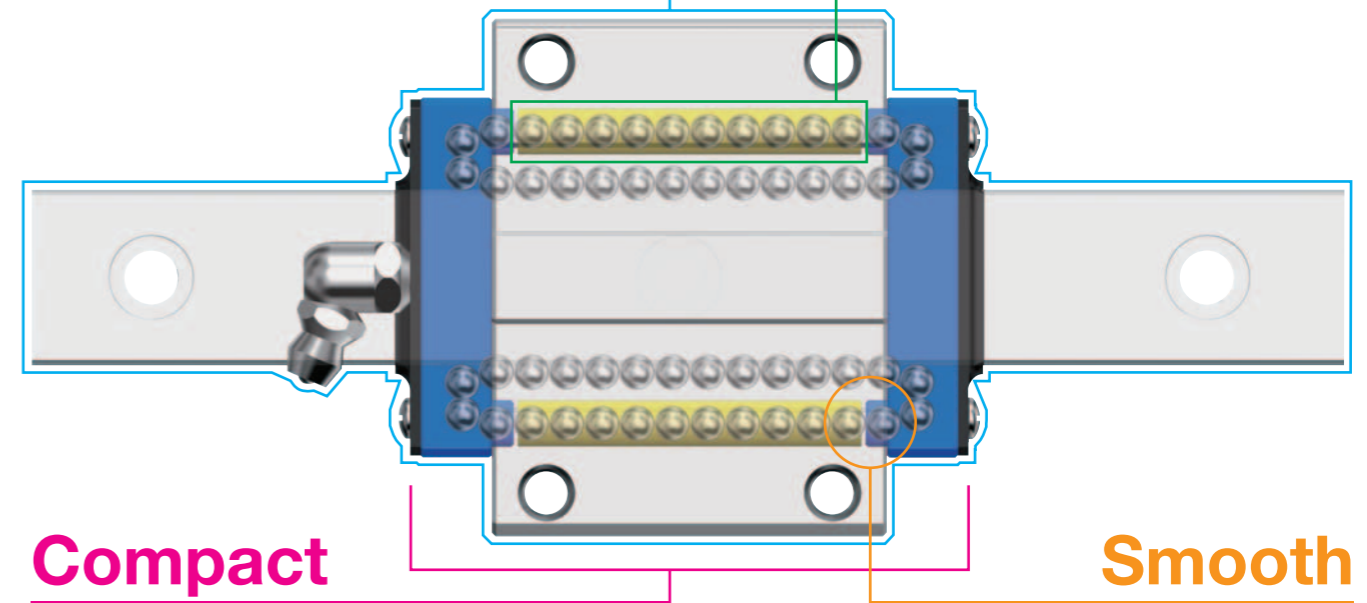

## Compact

No increase in carriage length unlike attached-on external lubrication parts. No loss of available stroke length when replacing standard units.

## Smooth

Light and smooth running is achieved by the improvement of design. It is designed not to have direct contact to track rail bringing very smooth friction.

## Lubricant supply mechanism of C-Sleeve system

### The circulation of the steel balls distributes lubricant.

Lubricant is supplied directly to the steel balls. As the steel balls circulate, the lubricant is distributed to the loading area along the track rail. This results in adequate lubrication being properly maintained in the loading area for a long time.

### Lubricant is deposited directly to the surface of the steel balls.

The surface of C-Sleeve is always covered with the lubricant. Lubricant is continuously supplied to the surface of steel ball by surface tension in the contact of C-Sleeve surface and steel balls. New oil permeates automatically from the core of C-Sleeve to the internal surface that comes in contact with steel balls.

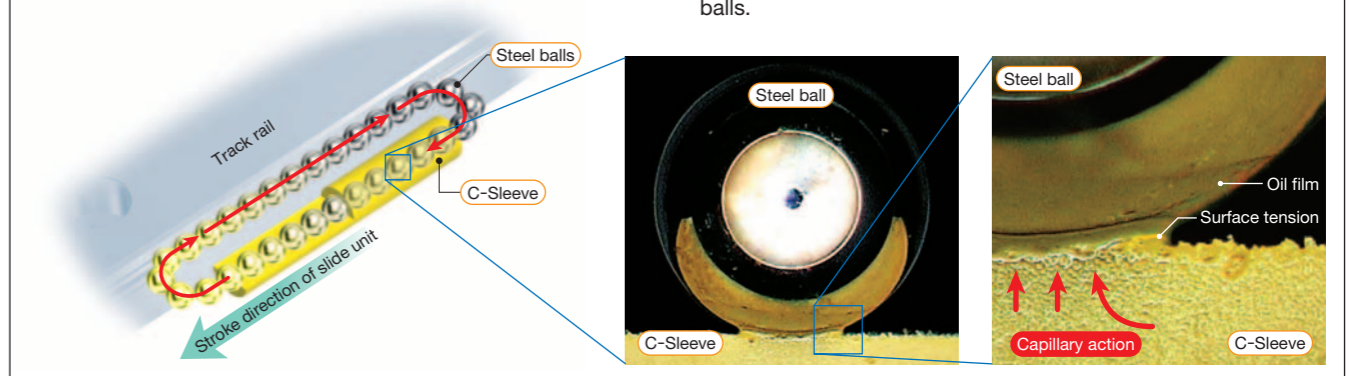

1N=0.102kgf=0.2248lbs.  
1mm=0.03937inch

Features of C-Sleeve Linear Way 2 ~Interchangeability~

# Interchangeable specification is newly available.

- 1 The slide unit and track rail can be ordered separately and can be assembled to make a set as required.
- 2 High level of flexibility as combination of any kinds of shape of the unit, accuracy classes and preload classes can be realized.
- 3 Slide units and track rails can be selected separately and it promises short delivery time when required.



The interchangeable specification is produced by **IKO** original precision manufacturing technology and the dimensional accuracy of both slide unit and track rail is strictly controlled to achieve the interchangeability of higher standard.

Requirements of ;

- Extending machine life and increase rigidity
- Improving machine accuracy
- Replace only the slide unit
- Increase number of slide unit
- Replace the track rail
- Extend length of the track rail
- Stock slide unit only as spare

Interchangeable specification realizes ;

- Quick design change.
- Giving higher accuracy and changing preload class.
- Slide unit and track rail can be assembled to other mechanical part individually.
- Any shape, accuracy and preload class of slide unit and track rail can be assembled.
- Slide unit and track rail can be stocked separately and it contributes minimum storage space.

### Interchangeability among types of slide unit

Various types of slide units with different sectional shapes and length are prepared. These entire slide units can be mounted on the same track rails freely when required.

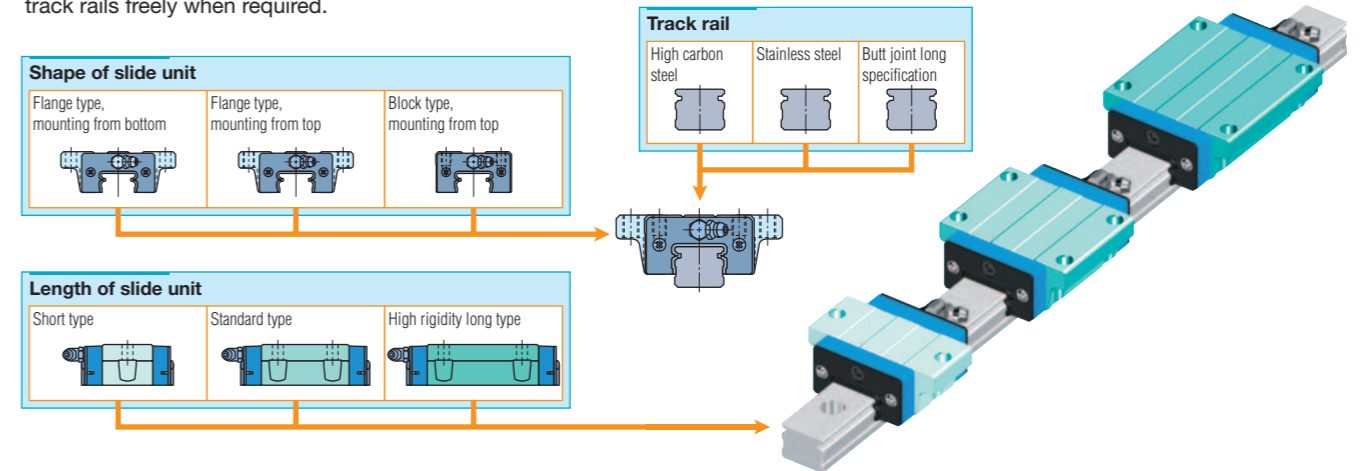

### Interchangeability in accuracy class

Two accuracy classes, High and Precision class are prepared and they can be used for application requiring high running accuracy. Furthermore, height variation among multiple sets is also controlled as well with high level of accuracy, ensuring that these products can be used for parallel track rail arrangement requires the degree of level strictly.

Three accuracy grades are available.

- Dimension  $H$  and  $N$
- Dimensional variation of  $H$  and  $N$  among in the one set
- Parallelism in the operation of  $\square C$  surface to  $\square A$  surface
- Parallelism in the operation of  $\square D$  surface to  $\square B$  surface

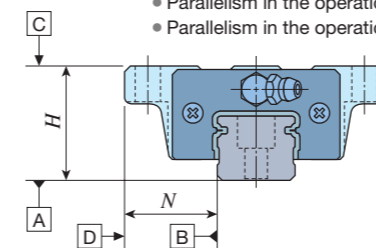

Suitable for using in the parallel.

- Dimensional variation of  $H$  dimension for multiple assembled sets

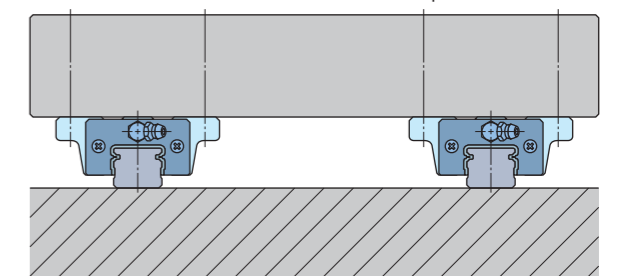

### Interchangeability in preload classes

High accuracy dimensional control owing to a simple structure has made it possible to realize the interchangeability in preloaded slide units. In the interchangeable specification products, several preload types are prepared so that these products can be used for application requiring increase rigidity.

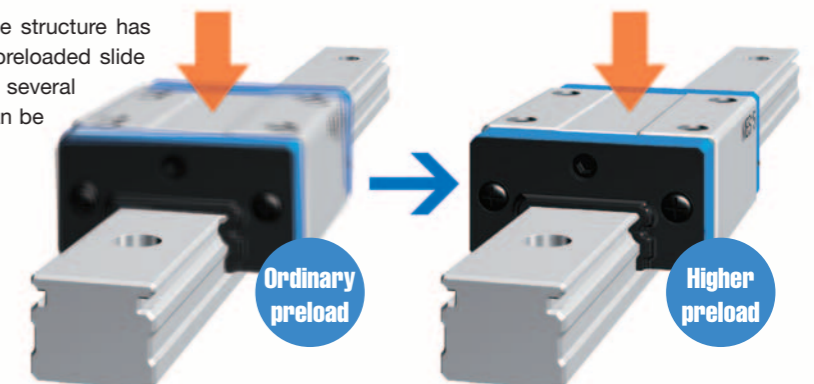
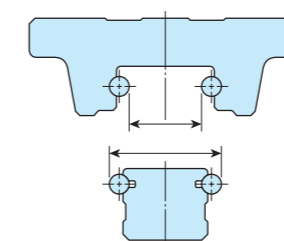

1N=0.102kgf=0.2248lbs.  
1mm=0.03937inch



# Features of C-Sleeve Linear Way 3 ~Wide variation~

## C-Sleeve Linear Way ML

Miniature type Linear Way from the smallest 5mm of track rail width. (Miniature size)

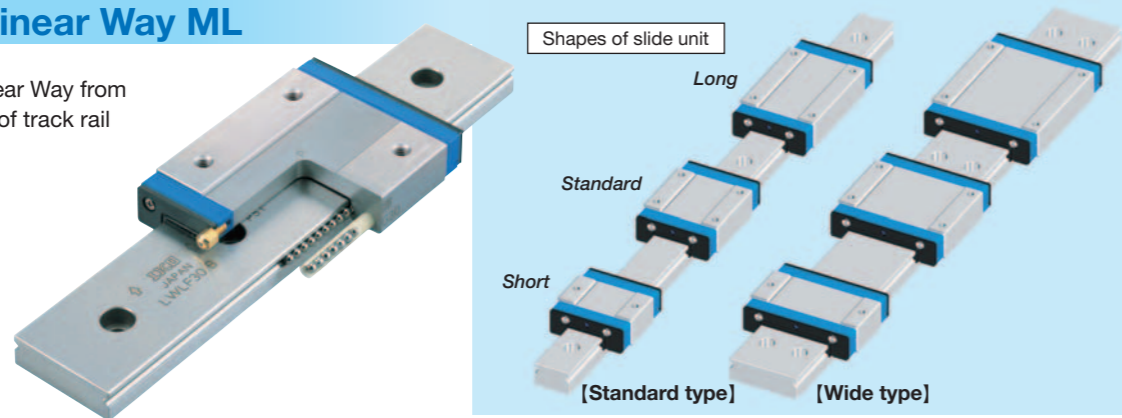

Size variation

Standard type



Wide type

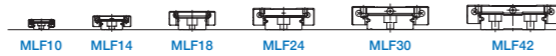

## C-Sleeve Linear Way ME

Useful compact sizes are suitable for general application. (Compact model)

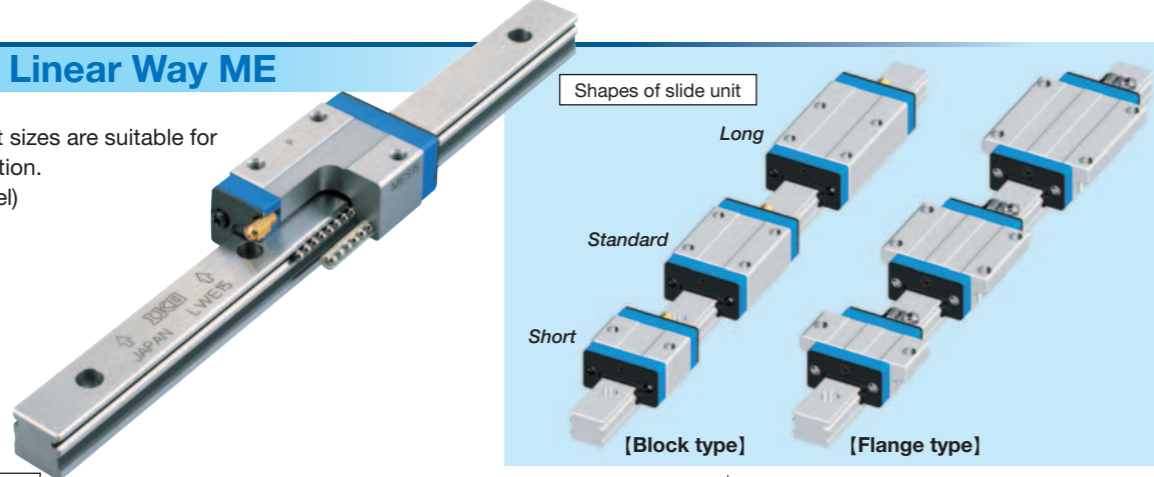

Size variation

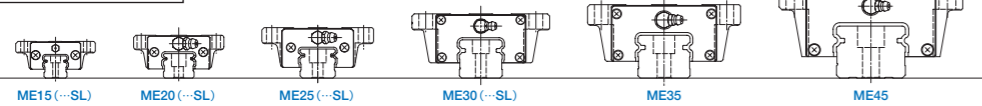

## C-Sleeve Linear Way MH

High rigidity and high load capacity model having bigger size of rolling element. (High load capacity)

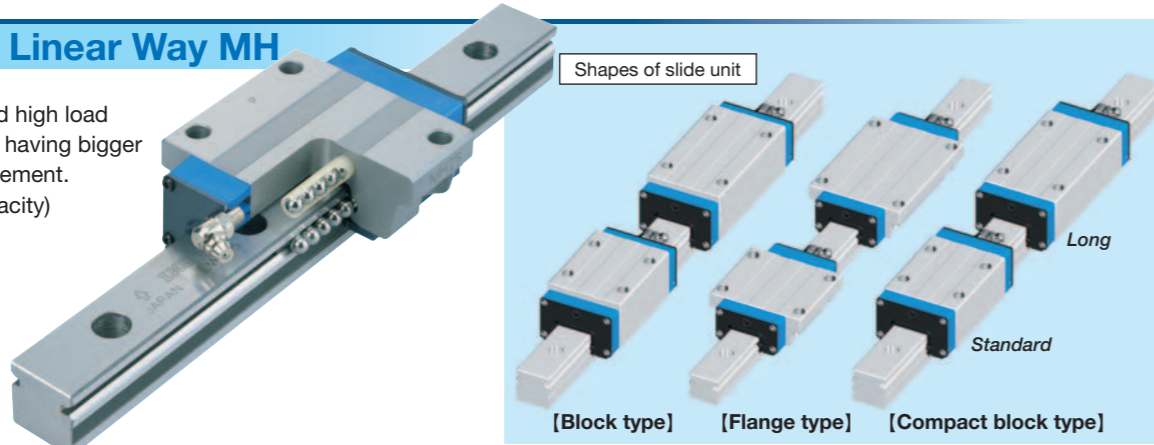

Size variation

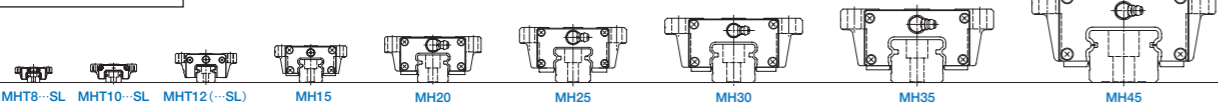

## C-Sleeve Linear Way MUL

High rigidity U-shaped track rail can be used as structural member of the machine. (High rigidity track rail)

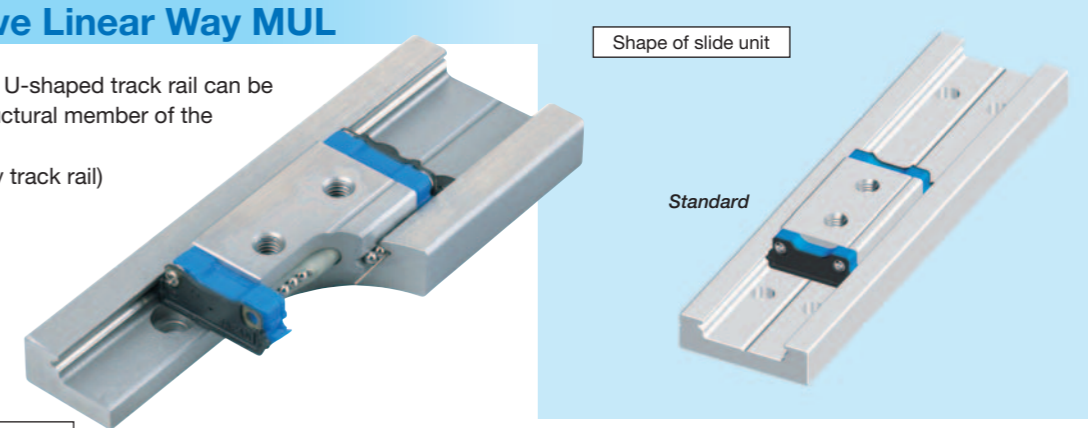

Size variation



### Variation of IKO C-Sleeve Linear Way

Series	Material	Shape of slide unit	Length of slide unit	Model code	Size		
C-Sleeve Linear Way ML	Stainless steel	Standard type	Short	MLC	5 7 9 12 15 20 25		
			Standard	ML	5 7 9 12 15 20 25		
			High rigidity long	MLG	- 7 9 12 15 20 25		
		Wide type	Short	MLFC	10 14 18 24 30 42		
			Standard	MLF	10 14 18 24 30 42		
			High rigidity long	MLFG	- 14 18 24 30 42		
C-Sleeve Linear Way ME	Carbon steel	Flange type, mounting from bottom	Short	MEC	15 20 25 30 35 -		
			Standard	ME	15 20 25 30 35 45		
			High rigidity long	MEG	15 20 25 30 - -		
		Flange type, mounting from top	Short	METC	15 20 25 30 35 -		
			Standard	MET	15 20 25 30 35 45		
			High rigidity long	METG	15 20 25 30 - -		
		Block type, mounting from top	Short	MESC	15 20 25 30 35 -		
			Standard	MES	15 20 25 30 35 45		
			High rigidity long	MESG	15 20 25 30 - -		
	Stainless steel	Flange type, mounting from bottom	Short	MEC...SL	15 20 25 30		
			Standard	ME...SL	15 20 25 30		
			High rigidity long	MEG...SL	15 20 25 30		
		Flange type, mounting from top	Short	METC...SL	15 20 25 30		
			Standard	MET...SL	15 20 25 30		
			High rigidity long	METG...SL	15 20 25 30		
		Block type, mounting from top	Short	MESC...SL	15 20 25 30		
			Standard	MES...SL	15 20 25 30		
			High rigidity long	MESG...SL	15 20 25 30		
C-Sleeve Linear Way MH	Carbon steel	Flange type, mounting from bottom	Standard	MH	- - - 15 20 25 30 35 45		
			High rigidity long	MHG	- - - 20 25 30 35 45		
		Flange type, mounting from top	Standard	MHT	8 10 12 15 20 25 30 35 45		
			High rigidity long	MHTG	- - - 20 25 30 35 45		
		Block type, mounting from top	Short	MHDC	8 10 12 - - - - -		
			Standard	MHD	8 10 12 15 - 25 30 35 45		
			High rigidity long	MHDG	8 10 12 - - 25 30 35 45		
		Compact block type, mounting from top	Standard	MHS	- - - 15 20 25 30 - -		
			High rigidity long	MHSG	- - - 20 25 30 - -		
			C-Sleeve Linear Way MUL	Stainless steel	Standard		MUL

1N=0.102kgf=0.2248lbs.  
1mm=0.03937inch

# Identification number

The specification of C-Sleeve Linear Way is identified by the identification number, which consists of a model code, a size, a part code, a preload symbol, a classification symbol, interchangeable code and special supplemental codes.

### Example of identification number

#### Interchangeable specification

Slide unit only **ML C 12 C1** **T<sub>1</sub> P S2 /U**

Track rail only <sup>(1)</sup> **LWL 12 R200 B** **P S2**

Set product **ML C 12 C2 R200** **T<sub>1</sub> P S2 /U**

#### Non-interchangeable specification

Set product **ML C 12 C2 R200** **T<sub>1</sub> P /U**

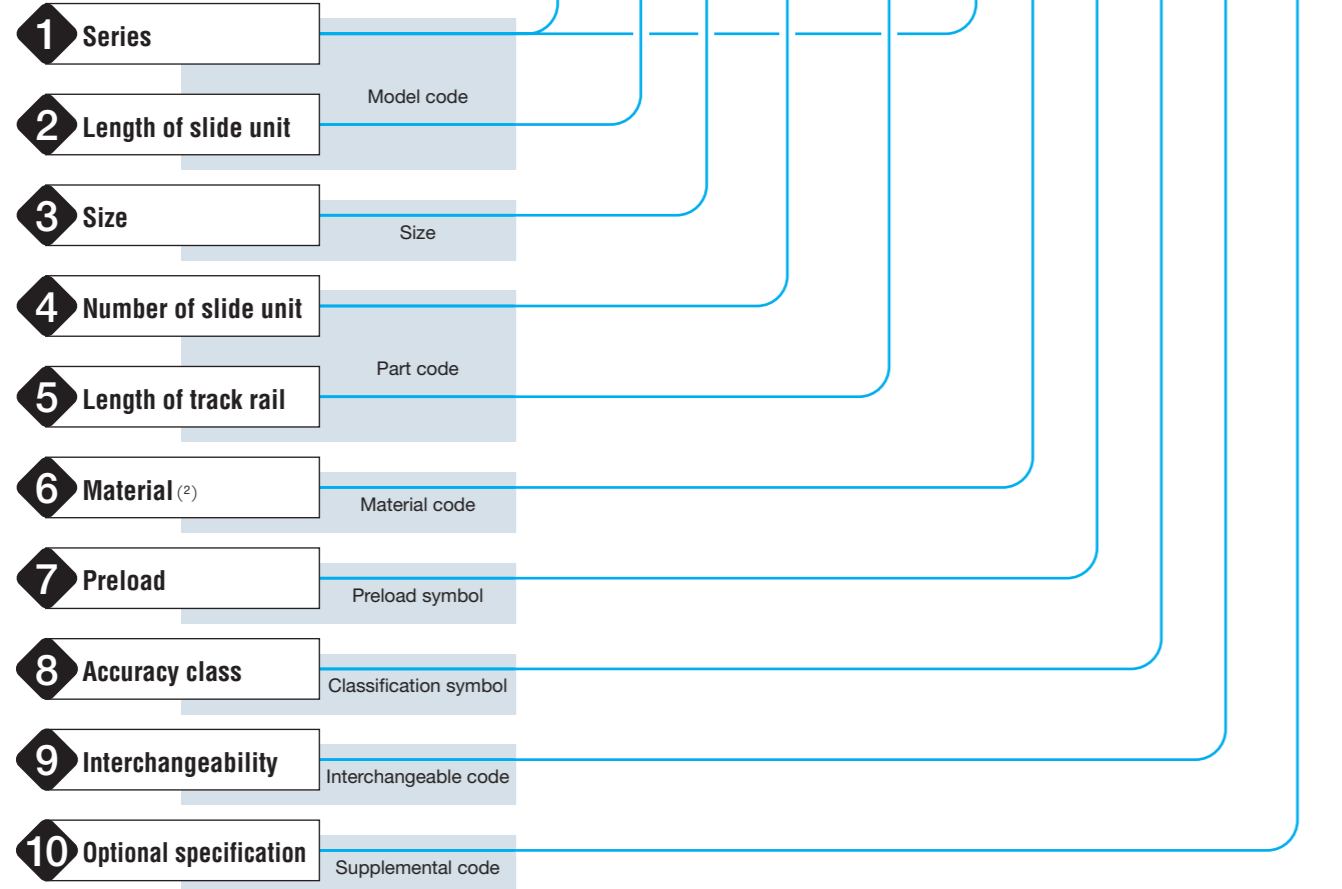

Note (1) : In case ordering track rail only, model code is changed as shown below.  
 Track rail of interchangeable ML → Model code LWL-B (Ex: LWL9R160BPS2)  
 Track rail of interchangeable MLF → Model code LWLF-B (Ex: LWLF42R320BPS2)  
 Track rail of interchangeable ME → Model code LWE (Ex: LWE20R820PS2)  
 Track rail of interchangeable MH → Model code LWH (Ex: LWH25R480BPS2)  
 (2) : Applicable to C-Sleeve Linear Way MH size 8 to 12.

## 1 Series

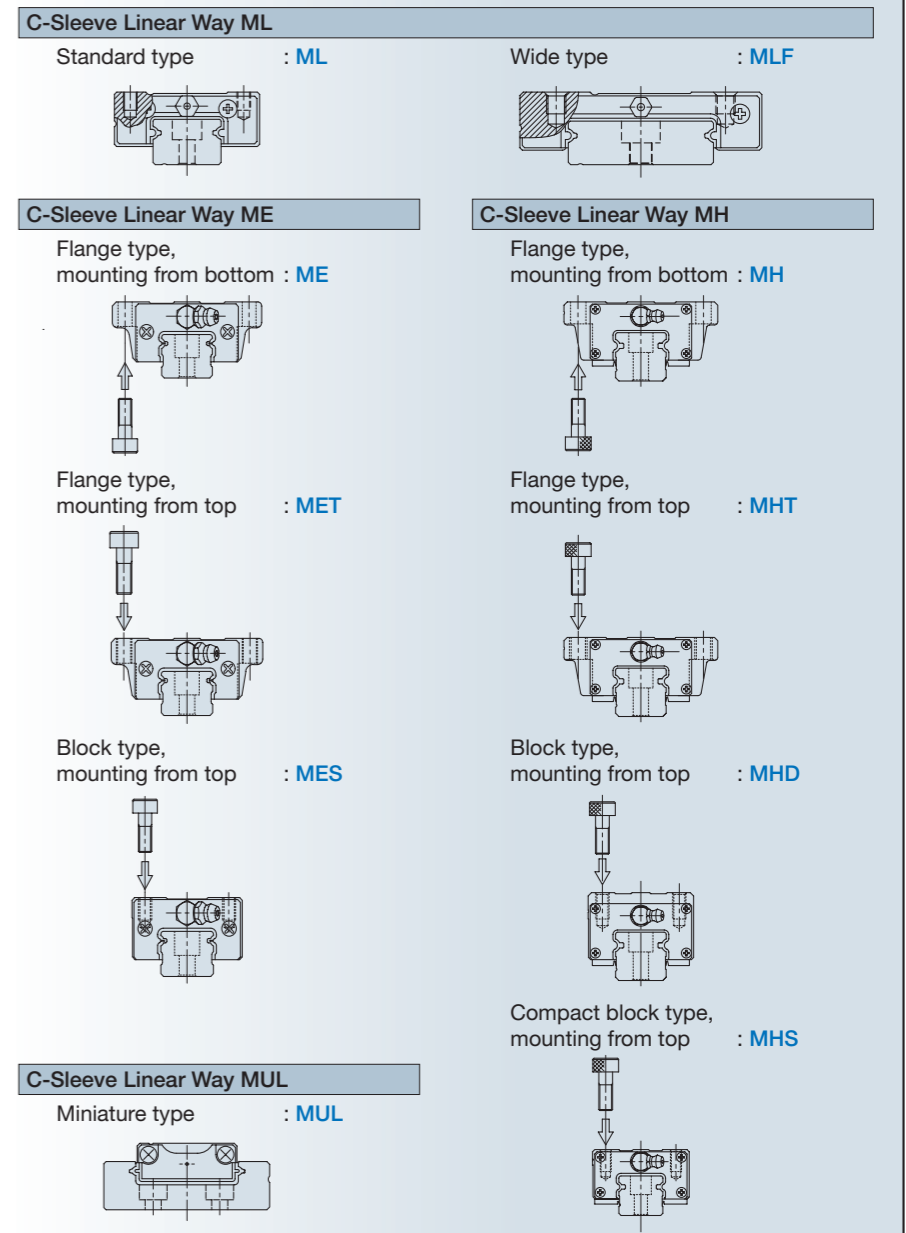

Applicable types and size are shown in Table 2.1 to 2.4 on the next page. Mode codes for ordering track rail only are shown in Table 1.

Table 1 Model codes for ordering track rail only

Series	Material	Model code of track rail
C-Sleeve Linear Way ML Standard type	Stainless steel	LWL...B
C-Sleeve Linear Way ML Wide type	Stainless steel	LWLF...B
C-Sleeve Linear Way ME	Carbon steel	LWE
	Stainless steel	LWE...SL
C-Sleeve Linear Way MH (Size 8 to 12)	Carbon steel	LWH
	Stainless steel	LWH...SL
C-Sleeve Linear Way MH (Size 15 to 45)	Carbon steel	LWH...B

## 2 Length of slide unit

- Short : C (Ex: MLC15C1S2)
- Standard : No symbol
- High rigidity long : G (Ex: MHG25C2R840H)

**3 Size**

Applicable types and size are shown in Table 2.1 to 2.4.

**Table 2.1 Types and sizes of C-Sleeve Linear Way ML**

Material	Shape of the slide unit	Length of the slide unit	Model code	Size						
				5	7	9	12	15	20	25
Stainless steel	Standard type	Short	MLC	☆	☆	☆	☆	☆	☆	☆
		Standard	ML	☆	☆	☆	☆	☆	☆	☆
		High rigidity long	MLG	—	☆	☆	☆	☆	☆	☆
	Wide type	Short	MLFC	☆	☆	☆	☆	☆	☆	☆
		Standard	MLF	☆	☆	☆	☆	☆	☆	☆
		High rigidity long	MLFG	—	☆	☆	☆	☆	☆	☆

Remark : ☆ marks indicates that interchangeable products are available.

**Table 2.2 Types and sizes of C-Sleeve Linear Way ME**

Material	Shape of the slide unit	Length of the slide unit	Model code	15	20	25	30	35	45
				Carbon steel	Flange type, mounting from bottom	Short	MEC	☆	☆
Standard	ME	☆	☆	☆		☆	☆	☆	
High rigidity long	MEG	☆	☆	☆		☆	—	—	
Carbon steel	Flange type, mounting from top	Short	METC	☆	☆	☆	☆	☆	—
		Standard	MET	☆	☆	☆	☆	☆	☆
		High rigidity long	METG	☆	☆	☆	☆	—	—
	Block type, mounting from top	Short	MESC	☆	☆	☆	☆	☆	—
		Standard	MES	☆	☆	☆	☆	☆	☆
		High rigidity long	MESG	☆	☆	☆	☆	—	—
Stainless steel	Flange type, mounting from bottom	Short	MEC...SL	☆	☆	☆	☆	—	—
		Standard	ME...SL	☆	☆	☆	☆	—	—
		High rigidity long	MEG...SL	☆	☆	☆	☆	—	—
	Flange type, mounting from top	Short	METC...SL	☆	☆	☆	☆	—	—
		Standard	MET...SL	☆	☆	☆	☆	—	—
		High rigidity long	METG...SL	☆	☆	☆	☆	—	—
	Block type, mounting from top	Short	MESC...SL	☆	☆	☆	☆	—	—
		Standard	MES...SL	☆	☆	☆	☆	—	—
		High rigidity long	MESG...SL	☆	☆	☆	☆	—	—

Remark : ☆ marks indicates that interchangeable products are available.

**Table 2.3 Types and sizes of C-Sleeve Linear Way MH**

Material	Shape of the slide unit	Length of the slide unit	Model code	8	10	12	15	20	25	30	35	45
				Carbon steel	Flange type, mounting from bottom	Standard	MH	—	—	—	☆	☆
High rigidity long	MHG	—	—			—	—	☆	☆	☆	☆	☆
Flange type, mounting from top	Standard	MHT <sup>(1)</sup>	—		—	☆	☆	☆	☆	☆	☆	☆
	High rigidity long	MHTG	—		—	—	—	☆	☆	☆	☆	☆
Block type, mounting from top	Standard	MHD	—		—	☆	☆	—	☆	☆	☆	☆
	High rigidity long	MHDG	—		—	—	—	—	☆	☆	☆	☆
Compact block type, mounting from top	Standard	MHS	—	—	—	☆	☆	☆	☆	—	—	
	High rigidity long	MHSG	—	—	—	—	☆	☆	☆	—	—	
Stainless steel	Flange type, mounting from bottom	Standard	MHT...SL	☆	☆	☆	—	—	—	—	—	—
		Short	MHDC...SL	☆	☆	☆	—	—	—	—	—	—
	Block type, mounting from top	Standard	MHD...SL	☆	☆	☆	—	—	—	—	—	—
		High rigidity long	MHDG...SL	☆	☆	☆	—	—	—	—	—	—

Note (1) : Size 12 can be mounted also from bottom.

Remark : ☆ marks indicates that interchangeable products are available.

**Table 2.4 Type and sizes of C-Sleeve Linear Way MUL**

Material	Shape of the slide unit	Length of the slide unit	Model code	25	30
Stainless steel	Miniature type	Standard	MUL	○	○

Remark : Interchangeable model is not available in MUL series.

**4 Number of slide unit**

Set product (with track rail)	: C○ (Ex : ME15C2R220)	For an assembled set, indicate the number of slide units assembled on one track rail. For an interchangeable slide unit only, "C1" shall be indicated.
Slide unit only (Interchangeable series)	: C1 (Ex : ME15C1S2)	
Track rail only	: No symbol	

**5 Length of track rail**

Set product (with slide unit)	: R○ (Ex:ME15C2R220)	Indicate the length of track rail in mm. For standard and maximum lengths, see "Track rail length" in Table 29.1 to 29.5 on page 32 to 34.
Slide unit only	: No symbol	
Track rail only (Interchangeable series)	: R○ (Ex:LWE15R220S2)	

**6 Material**

Stainless steel	: SL <sup>(1)</sup>	Specify this item for an assembled set or an interchangeable track rail of C-Sleeve Linear Way MH size 8 to 12. For detail, see Table 2.3 on page 13. Note (1) : Stainless steel is available to ME15 to ME30 and MH8 to MH12.
-----------------	---------------------	---

**7 Preload**

Clearance for ML	: T <sub>0</sub>	Specify this items for an assembled set or an interchangeable single slide unit. Applicable preload and size are shown in Table 3. For details of preload amount, see Table 14 on page 20.
Clearance for ME	: T <sub>c</sub>	
Standard	: No symbol	
Light preload	: T <sub>1</sub>	
Medium preload	: T <sub>2</sub>	
Heavy preload	: T <sub>3</sub>	

**8 Accuracy class**

Ordinary class	: No symbol	For applicable accuracy, see Table 3. In the interchangeable specification, please combine same accuracy codes on both slide unit and track rail. For details of accuracy, see Table 13.1 to 13.3 on page 19 to 20.
High class	: H	
Precision class	: P	
Super precision class	: SP	

**Table 3 Preload of C-Sleeve Linear Way**

Series	Preload class and symbol					
	Clearance for ME (T <sub>c</sub> )	Clearance for ML (T <sub>0</sub> )	Standard (No symbol)	Light preload (T <sub>1</sub> )	Medium preload (T <sub>2</sub> )	Heavy preload (T <sub>3</sub> )
C-Sleeve Linear Way ML	—	☆ <sup>(1)</sup>	☆	☆ <sup>(2)</sup>	—	—
C-Sleeve Linear Way ME <sup>(3)</sup>	☆	—	☆	☆	○	—
C-Sleeve Linear Way MH	—	○ <sup>(4)</sup>	☆	☆ <sup>(5)</sup>	○ <sup>(6)</sup>	○ <sup>(6)</sup>
C-Sleeve Linear Way MUL	—	—	○	○	—	—

Note (1) : Not applicable to supplemental code /HB (Ceramic ball specification)  
 (2) : Not applicable to size 5 and 10.  
 (3) : In ME series, applicable combination of the preload and accuracy is limited and shown in Table 5.  
 (4) : Applicable to size 8, 10 and 12.  
 (5) : Not applicable to interchangeable specification of size 8, 10 and 12.  
 (6) : Not applicable to size 8, 10 and 12.

Remark : ☆ marks are also applicable for interchangeable series.

**Table 4 Accuracy of C-Sleeve Linear Way**

Series	Accuracy class and symbol			
	Ordinary class (No symbol)	High class (H)	Precision class (P)	Super precision class (SP)
C-Sleeve Linear Way ML	—	☆	☆	—
C-Sleeve Linear Way ME <sup>(1)</sup>	☆	☆	☆	○
C-Sleeve Linear Way MH	—	☆	☆	○ <sup>(2)</sup>
C-Sleeve Linear Way MUL	○	○	—	—

Note (1) : In ME series, applicable combination of the preload and accuracy is limited and shown in Table 5.  
 (2) : Not applicable to size 8, 10 and 12.

Remark : ☆ marks are also applicable for interchangeable series.

**Table 5 C-Sleeve Linear Way ME Combination of accuracy and preload**

Preload class and symbol	Accuracy class and symbol	Ordinary class (No symbol)	High class (H)	Precision class (P)	Super precision class (SP)
Clearance for ME (T <sub>c</sub> )		☆	—	—	—
Standard (No symbol)		☆	☆	☆	○
Light preload (T <sub>1</sub> )		—	☆	☆	○
Medium preload (T <sub>2</sub> )		—	○	○	○

Remark : ☆ marks are also applicable for interchangeable series.



**9 Interchangeability**

Interchangeable : S2  
 Non-interchangeable : No symbol  
 Slide unit and track rail can be supplied separately by indicating interchangeable code S2.

**10 Optional specification**

Applicable special specifications are shown in Table 6.1 to 6.4. When a combination of several special specifications (Table 7.1 to 7.4) is required, arrange their supplemental codes in alphabetical order. For detail of special specifications, see page 21 to 27.

**Table 6.1 C-Sleeve Linear Way ML Applicable optional specifications**

Specifications	Supplemental code	Set product	Track rail only	Slide unit only
Butt jointing track rail	/A	○	—	—
Opposite reference surfaces arrangement	/D	☆	—	—
Specified rail mounting hole positions	/E	☆	☆	—
Ceramic balls	/HB	○ <sup>(1)</sup>	—	—
Appending inspection sheet	/I	○	—	—
Black chrome surface treatment	/LR	○ <sup>(2)</sup>	—	—
Without track rail mounting bolts	/MN	☆	☆	—
No rubber end seals	/N	☆	—	☆
Track rail with stopper pins	/S	○	—	—
Under seals	/U	☆ <sup>(3)</sup>	—	☆ <sup>(3)</sup>
Matched sets to be used as an assembled group	/W○	○	—	—

Note (1) : Applicable to size 7, 9, 12 and 15.  
 (2) : Not applicable to size 5 and 10.  
 (3) : Not applicable to size 5, 7, 10 and 14.  
 Remark : ☆ marks indicates that interchangeable products are available.

**Table 6.2 C-Sleeve Linear Way ME Applicable optional specifications**

Specifications	Supplemental code	Set product	Track rail only	Slide unit only
Butt jointing track rail	/A	○	—	—
Opposite reference surfaces arrangement	/D	☆	—	—
Specified rail mounting hole positions	/E	☆	☆	—
Caps for rail mounting holes	/F	☆	☆	—
Append an inspection sheet	/I	○	—	—
Female threads for bellows	/J○	☆ <sup>(1)</sup>	☆ <sup>(1)</sup>	☆ <sup>(1)</sup>
Black chrome surface treatment	/L○	☆	—	—
Fluoric black chrome surface treatment	/LF○	☆	—	—
With track rail mounting bolts	/MA	☆	☆	—
Change of mounting hole size	/M4	☆ <sup>(2)</sup>	☆ <sup>(2)</sup>	—
No rubber end seals	/N	☆	—	☆
Butt jointing interchangeable track rail	/T	☆ <sup>(3)</sup>	☆	—
Under seals	/U	☆	—	☆
Double end seals	/V○	☆	—	☆
Matched sets to be used as an assembled group	/W○	○	—	—
Scrapers	/Z○	☆	—	☆

Note (1) : Not applicable to interchangeable specification of stainless steel model.  
 (2) : Applicable to size 15.  
 (3) : Not applicable to on interchangeable specification.  
 Remark : ☆ marks indicates that interchangeable products are available.

**Table 6.3 C-Sleeve Linear Way MH Applicable optional specifications**

Specifications	Supplemental code	Set product	Track rail only	Slide unit only
Butt jointing track rail	/A	○ <sup>(1)</sup>	—	—
Opposite reference surfaces arrangement	/D	☆	—	—
Specified rail mounting hole positions	/E	☆	☆	—
Caps for rail mounting holes	/F	☆ <sup>(2)</sup>	☆ <sup>(2)</sup>	—
Append an inspection sheet	/I	○	—	—
Female threads for bellows	/J○	☆ <sup>(3)</sup>	☆ <sup>(3)</sup>	☆ <sup>(3)</sup>
Black chrome surface treatment	/L○	☆ <sup>(4)</sup>	—	—
Fluoric black chrome surface treatment	/LF○	☆ <sup>(3)</sup>	—	—
With track rail mounting bolts (Applicable to set order)	/MA	☆	—	—
Without track rail mounting bolts (Applicable to track rail order)	/MN	—	☆	—
No rubber end seals	/N	☆	—	☆
Rail cover plate	/PS	○ <sup>(5)</sup>	—	—
Butt jointing interchangeable track rail	/T	☆ <sup>(3)(6)</sup>	☆ <sup>(3)</sup>	—
Under seals	/U	☆ <sup>(7)</sup>	—	☆ <sup>(7)</sup>
Double end seals	/V○	☆ <sup>(3)</sup>	—	☆ <sup>(3)</sup>
Matched sets to be used as an assembled group	/W○	○	—	—
Scrapers	/Z○	☆ <sup>(3)</sup>	—	☆ <sup>(3)</sup>

Note (1) : Not applicable to size 12 of carbon steel product.  
 (2) : Not applicable to size 8 and 10.  
 (3) : Not applicable to size 8, 10 and 12.  
 (4) : Only "LR" is applicable to size 8, 10 and 12.  
 (5) : Not applicable to size 8, 10, 12, 15 and 20.  
 (6) : Not applicable to non interchangeable specification  
 (7) : Applicable to size 8, 10 and 12.  
 Remark : ☆ marks indicates that interchangeable products are available.

**Table 6.4 C-Sleeve Linear Way MUL Applicable optional specifications**

Specifications	Supplemental code	Non-interchangeable specification
Specified rail mounting hole positions	/E	○
Black chrome surface treatment	/LR	○
With track rail mounting bolts	/MA	○
Upper seals	/U	○
Matched sets to be used as an assembled group	/W○	○

**Table 7.1 C-Sleeve Linear Way ML Combination of optional specifications**

D	○											
E	—	—										
HB	○	○	○									
I	○	○	○	○								
LR	—	○	○	○	○							
MN	○	☆	☆	○	○	○						
N	○	☆	☆	○	○	○	☆					
S	○	○	○	○	○	○	○	○				
U	○	☆	☆	○	○	○	☆	—	○			
W	○	○	—	○	○	○	○	○	○	○		
	A	D	E	HB	I	LR	MN	N	S	U		

Remark 1 : ○ marks indicates that this combination can be made.  
 2 : ☆ marks indicates that the combination is available for also interchangeable specification.

**Table 7.2 C-Sleeve Linear Way ME Combination of optional specifications**

D	○														
E	—	—													
F	○	☆	☆												
I	○	○	○	○											
J	○	☆	☆	☆	☆	○									
L	○	☆	☆	☆	☆	○	☆								
LF	○	☆	☆	☆	☆	○	☆	—							
MA	○	☆	☆	☆	☆	○	☆	☆	☆						
M4	○	☆	☆	☆	☆	○	☆	☆	☆	☆ <sup>(1)</sup>					
N	○	☆	☆	—	○	—	☆	☆	☆	☆					
T	—	☆	☆	☆	—	—	☆	☆	☆	☆	☆				
U	○	☆	☆	☆	○	☆	☆	☆	☆	☆	—	☆			
V	○	☆	☆	☆	○	★	☆	☆	☆	☆	—	☆	☆		
W	○	○	—	○	○	○	○	○	○	○	○	○	○	○	○
Z	○	☆	☆	☆	○	★	☆	☆	☆	☆	—	☆	☆	★	○
	A	D	E	F	I	J	L	LF	MA	M4	N	T	U	V	W

Note (1) : When a combination of "MA" and "M4" is necessary, indicate "MA4".  
 Remark 1 : ○ marks indicates that this combination can be made.  
 2 : ☆ marks indicates that the combination is available for also interchangeable specification.  
 3 : Please consult ⑩⑪⑫ when ★ marks required.

**Table 7.3 C-Sleeve Linear Way MH Combination of optional specifications**

D	○															
E	—	—														
F	○	☆	☆													
I	○	○	○	○												
J	○	☆	☆	☆	○											
L	○	☆	☆	☆	○	☆										
LF	○	☆	☆	☆	○	☆	—									
MA	○	☆	☆	☆	○	☆	☆	☆								
MN	○	—	☆	☆	○	☆	—	—	—							
N	○	☆	☆	—	○	—	☆	☆	☆	—						
PS	—	○	○	—	○	—	—	—	○	—	—					
T	—	☆	☆	☆	—	—	☆	☆	☆	☆	—					
U	○	☆	☆	☆	○	☆	☆	☆	☆	—	—	—	☆			
V	○	☆	☆	☆	○	★	☆	☆	☆	—	—	○	☆	☆		
W	○	○	—	○	○	○	○	○	○	—	○	○	—	○	○	
Z	○	☆	☆	☆	○	★	☆	☆	☆	—	—	—	☆	☆	★	
	A	D	E	F	I	J	L	LF	MA	MN	N	PS	T	U	V	W

Remark 1 : ○ marks indicates that this combination can be made.  
 2 : ☆ marks indicates that the combination is available for also interchangeable specification.  
 3 : Please consult ⑩⑪⑫ when ★ marks required.

**Table 7.4 C-Sleeve Linear Way MUL Combination of optional specifications**

LR	○			
MA	○	○		
U	○	○	○	
W	—	○	○	○
	E	LR	MA	U

Remark 1 : ○ marks indicates that this combination can be made.

# Load Ratings and Life

## Basic dynamic load rating $C$

Conforming to ISO/FDIS 14728-1

The basic dynamic load rating is defined as a constant load both in direction and magnitude under which a group of identical C-Sleeve Linear Ways are individually operated and 90% of those in the group can travel  $50 \times 10^3 \text{m}$  free from material damage due to rolling contact fatigue.

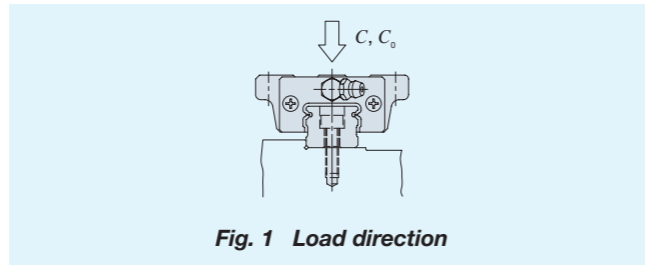

Fig. 1 Load direction

## Basic static load rating $C_0$

Conforming to ISO/FDIS 14728-2

The basic static load rating is defined as a static load that gives a prescribed constant contact stress at the center of the contact area between rolling elements and raceways receiving the maximum load.

## Static moment rating $T_0, T_x, T_y$

The static moment rating is defined as a static moment load (See Fig.2) that gives a prescribed constant contact stress at the center of the contact area between rolling elements and raceways receiving the maximum load.

The static moment rating is used in combination with the static safety factor to give the limiting load for normal rolling motion.

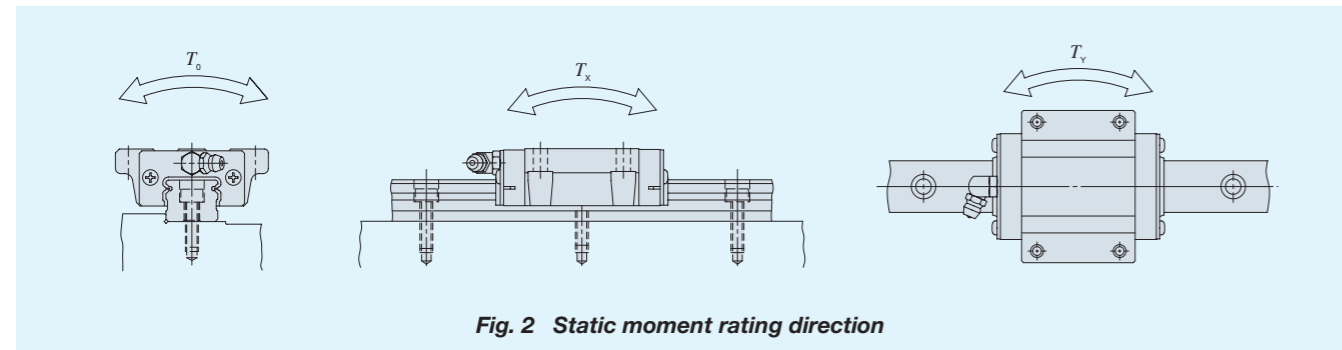

Fig. 2 Static moment rating direction

## Life

The rating life of C-Sleeve Linear Way series is obtained from the following calculation formula.

$$L = 50 \left( \frac{C}{P} \right)^3 \dots\dots\dots (1)$$

where,  $L$  : Rating life,  $10^3 \text{m}$   
 $C$  : Basic dynamic load rating, N  
 $P$  : Equivalent load, N

If the stroke length and the number of strokes per minute are known, the life in hours must be corrected by the following formula.

$$L_h = \frac{10^6 L}{2Sn_1 \times 60} \dots\dots\dots (2)$$

where,  $L_h$  : Rating life in hours, hours  
 $S$  : Stroke length, mm  
 $n_1$  : Number of strokes per minute, cpm

## Static safety factor

The static safety factor  $f_s$  of C-Sleeve Linear Way series is given in the following formula, and general values of this factor are shown in Table 8.

$$f_s = \frac{C_0}{P_0} \dots\dots\dots (3)$$

where,  $f_s$  : Static safety factor  
 $C_0$  : Basic static load rating, N  
 $P_0$  : Static load, N

Table 8 Static safety factor

Operating conditions	$f_s$
Operation with vibration and/or shocks	3 ~ 5
High operating performance	2 ~ 4
Normal operation	1 ~ 3

## Load factor

Actual loads applied to the linear motion rolling guide sometimes exceed the theoretically calculated load due to vibration and shocks caused by machine operation. The actual life is calculated from the following formula while considering the load factor.

Table 9 Load factor

Condition	$f_w$
Smooth operation free from vibration and/or shocks	1 ~ 1.2
Normal operation	1.2 ~ 1.5
Operation with shock loads	1.5 ~ 3

## Dynamic equivalent load

When there is any load in the direction other than basic dynamic load rating or combined load, dynamic equivalent load is obtained for life calculation.

From each directional load, converted load equal to downward or lateral is given by following formulae.

$$F_{ro} = k_r |F_r| + \frac{C_0}{T_0} |M_0| + \frac{C_0}{T_x} |M_x| \dots\dots\dots (4)$$

$$F_{ao} = k_a |F_a| + \frac{C_0}{T_y} |M_y| \dots\dots\dots (5)$$

where,  $F_{ro}$  : Converted downward load, N  
 $F_{ao}$  : Converted lateral load, N  
 $F_r$  : Downward load, N  
 $F_a$  : Lateral load, N  
 $M_0$  :  $T_0$  moment, N·m  
 $M_x$  :  $T_x$  moment, N·m  
 $M_y$  :  $T_y$  moment, N·m  
 $k_r, k_a$  : Conversion factor by load direction (See Table 10)  
 $C_0$  : Basic static load rating, N  
 $T_0$  :  $T_0$  static moment, N·m  
 $T_x$  :  $T_x$  static moment, N·m  
 $T_y$  :  $T_y$  static moment, N·m

Table 10 Conversion factor by load direction

Series	Conversion factor		
	$k_r$		$k_a$
	$F_r \geq 0$	$F_r < 0$	
C-Sleeve Linear Way ML	1	1	1.19
C-Sleeve Linear Way ME	15~30	1	1
	35~45	1	1.19
C-Sleeve Linear Way MH	8~12	1	1
	15~30	1	1
	35~45	1	1.19
C-Sleeve Linear Way MUL	1	1	1.19

From the converted downward and lateral load, mean equivalent dynamic load must be corrected by the following formula.

$$P = XF_{ro} + YF_{ao} \dots\dots\dots (6)$$

where,  $P$  : Mean equivalent dynamic load, N  
 $X, Y$  : Mean equivalent dynamic load factor (See Table 11)  
 $F_{ro}$  : Converted downward load, N  
 $F_{ao}$  : Converted lateral load, N

Table 11 Mean equivalent dynamic load factor

Condition	X	Y
$ F_{ro}  \geq  F_{ao} $	1	0.6
$ F_{ro}  <  F_{ao} $	0.6	1

## Static equivalent load

When there is any load in the direction other than basic dynamic load rating or combined load, mean equivalent static load is obtained for static safety factor calculation.

From each directional load, converted load equal to downward or lateral is given by following formula.

$$P_0 = k_{or} |F_r| + k_{oa} |F_a| + \frac{C_0}{T_0} |M_0| + \frac{C_0}{T_x} |M_x| + \frac{C_0}{T_y} |M_y| \dots\dots\dots (7)$$

where,  $P_0$  : Static equivalent load, N  
 $F_r$  : Downward load, N  
 $F_a$  : Lateral load, N  
 $M_0$  :  $T_0$  moment, N·m  
 $M_x$  :  $T_x$  moment, N·m  
 $M_y$  :  $T_y$  moment, N·m  
 $k_{or}, k_{oa}$  : Conversion factor by load direction (See Table 12)  
 $C_0$  : Basic static load rating, N  
 $T_0$  :  $T_0$  static moment, N·m  
 $T_x$  :  $T_x$  static moment, N·m  
 $T_y$  :  $T_y$  static moment, N·m

Table 12 Conversion factor by load direction

Series	Conversion factor		
	$k_{or}$		$k_{oa}$
	$F_r \geq 0$	$F_r < 0$	
C-Sleeve Linear Way ML	1	1	1.19
C-Sleeve Linear Way ME	15~30	1	1
	35~45	1	1.19
C-Sleeve Linear Way MH	8~12	1	1
	15~30	1	1
	35~45	1	1.19
C-Sleeve Linear Way MUL	1	1	1.19



Accuracy of the assembled set of C-Sleeve Linear Way are shown in Table 13.1 to 13.3.

Table 13.1 Accuracy of C-Sleeve Linear Way ME and MH

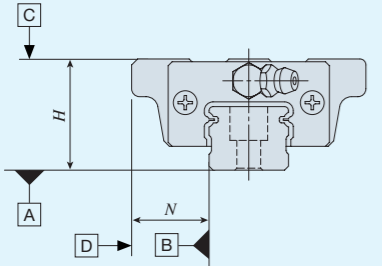

Item	Classification (Symbol)	Ordinary (No symbol)	High (H)	Precision (P)	Super precision (SP)
Dim. $H$ Tolerance		$\pm 0.080$	$\pm 0.040$	$\pm 0.020$	$\pm 0.010$
Dim. $N$ Tolerance		$\pm 0.100$	$\pm 0.050$	$\pm 0.025$	$\pm 0.015$
Dim. variation of $H^{(1)}$		0.025	0.015	0.007	0.005
Dim. variation of $N^{(1)}$		0.030	0.020	0.010	0.007
Dim. variation of $H^{(2)}$ for multiple sets		0.045	0.035	0.025	—
Parallelism in operation of $\text{C}$ to $\text{A}$		Refer to Fig. 3.1			
Parallelism in operation of $\text{D}$ to $\text{B}$		Refer to Fig. 3.1			

unit : mm

Table 13.2 Accuracy of C-Sleeve Linear Way ML

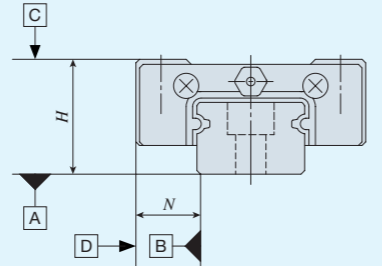

Item	Classification (Symbol)	High (H)	Precision (P)
Dim. $H$ Tolerance		$\pm 0.020$	$\pm 0.010$
Dim. $N$ Tolerance		$\pm 0.025$	$\pm 0.015$
Dim. variation of $H^{(1)}$		0.015	0.007
Dim. variation of $N^{(1)}$		0.020	0.010
Dim. variation of $H^{(2)}$ for multiple sets		0.030	0.020
Parallelism in operation of $\text{C}$ to $\text{A}$		Refer to Fig. 3.2	
Parallelism in operation of $\text{D}$ to $\text{B}$		Refer to Fig. 3.2	

unit : mm

Table 13.3 Accuracy of C-Sleeve Linear Way MUL

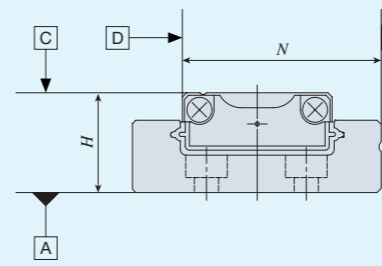

Item	Classification (Symbol)	Ordinary (No symbol)	High (H)
Dim. $H$ Tolerance		$\pm 0.100$	$\pm 0.050$
Dim. $N$ Tolerance		$\pm 0.100$	$\pm 0.050$
Dim. variation of $H^{(1)}$		0.050	0.040
Dim. variation of $N^{(1)}$		0.050	0.040
Parallelism in operation of $\text{C}$ to $\text{A}$		Refer to Fig. 3.3	
Parallelism in operation of $\text{D}$ to $\text{B}$		Refer to Fig. 3.3	

unit : mm

Note (1) : Dimensional variation of dimension means the size variation between the slide units mounted on the same track rail when the dimension  $H$  is measured at the same measuring position of track rail.

(2) : Applicable to interchangeable specification.

Remark 1 : These values also apply to C-Sleeve Linear Way Interchangeable series that has opposite reference surface arrangements.

2 : Dimensional variation of dimension  $H$  for multiple sets means the variation of dimension  $H$  among multiple sets of arbitrarily chosen slide unit and track rail of C-Sleeve Linear Way Interchangeable series.

3 : All of above figures are applicable when the dimensions are measured at the center of each slide unit assembled with a track rail fixed onto a flat base.

4 : For accuracy of C-Sleeve Linear Way MH size 8, 10 and 12, Table 13.2 is applicable.

Note (1) : Dimensional variation of dimension means the size variation between the slide units mounted on the same track rail when the dimension  $H$  is measured at the same measuring position of track rail.

Remark : All of above figures are applicable when the dimensions are measured at the center of each slide unit assembled with a track rail fixed onto a flat base.

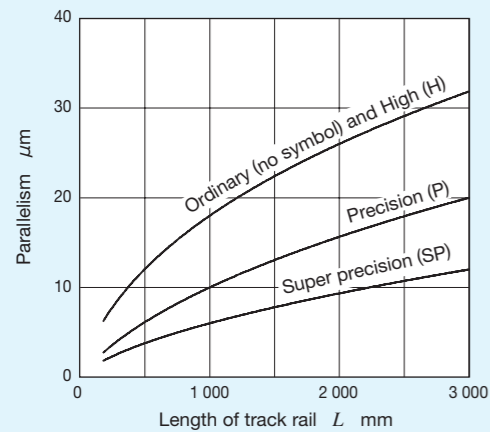

Fig. 3.1 C-Sleeve Linear Way ME and MH Parallelism in operation

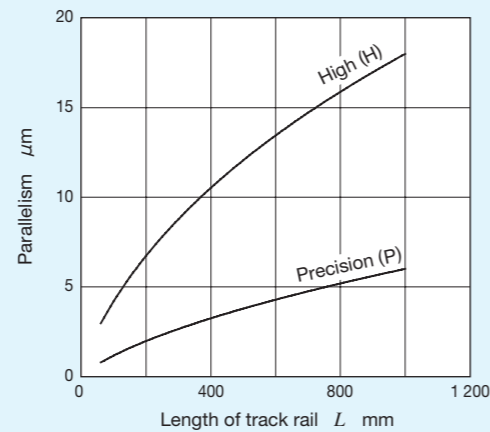

Fig. 3.2 C-Sleeve Linear Way ML Parallelism in operation

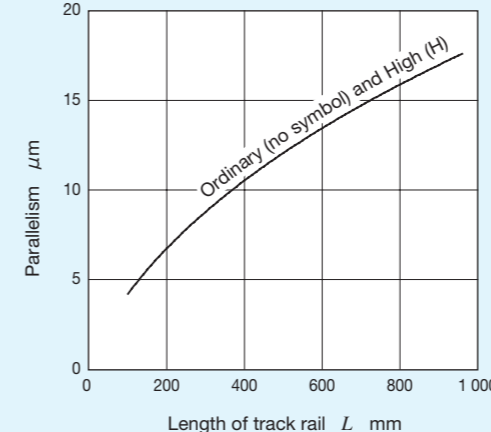

Fig. 3.3 C-Sleeve Linear Way MUL Parallelism in operation

Average amount of preload for C-Sleeve Linear Way series is shown in Table 14. In case, high rigidity and/or damping are needed, the preload amount is recommended to be 1/3 of the external force. However, excessive preload will cause short life.

Table 14 Preload amount

Preload class	Item Symbol	Preload amount N	Typical application
Clearance	$T_C$	0 <sup>(1)</sup>	• Smooth motion • To absorb slight misalignment
	$T_0$	0 <sup>(2)</sup>	• Smooth motion
Standard preload	(No symbol)	0 <sup>(3)</sup>	• Smooth and precise motion
Light preload	$T_1$	0.02 $C_0$	• Minimum vibration • Load is equally balanced. • Smooth and precise motion
	$T_2$	0.05 $C_0$	• Medium vibration • Medium overhung load
Heavy preload	$T_3$	0.08 $C_0$	• Vibration and/or shocks • Large overhung load • Heavy cutting

Note (1) : Approx. 10µm clearance

(2) : Zero or minimal amount of clearance

(3) : Zero or minimal amount of preload

Remark :  $C_0$  means basic static load rating.

Geometrical moment of inertia

High rigidity design of C-Sleeve Linear Way MUL is achieved by adopting a U-shaped track rail. Table 15 shows the moment of inertia of sectional area of track rails.

Table 15 C-Sleeve Linear Way MUL Moment of inertia of sectional area of track rails

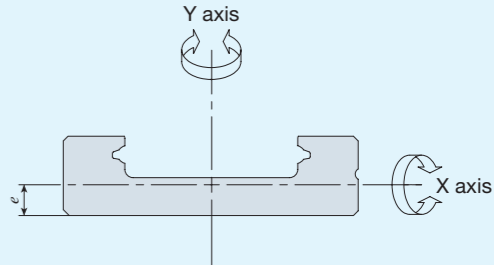

Model number	Moment of inertia of sectional area mm <sup>4</sup>		Center of gravity e mm
	$I_x$	$I_y$	
MUL 25	$3.7 \times 10^2$	$7.5 \times 10^3$	2.6
MUL 30	$9.3 \times 10^2$	$1.7 \times 10^4$	3.3

# Optional special specifications for use under special environment

C-Sleeve Linear Way series with the special specifications shown in Table 6.1 to 6.4 are optionally available for various applications. When ordering, add any supplemental codes onto the identification number.

If a combination of special specifications is required, indicate the supplemental codes in alphabetical order. These optional items can be combined to achieve further improvements in performance.

## Butt jointing track rails

/A



When the required length of non-interchangeable track rail exceeds the maximum length shown in page 32 to 34, two or more track rails can be used by butt jointing them in the direction of linear motion. For the length and the number of butt jointing track rails, please consult IKO.

## Opposite reference surfaces arrangement

/D

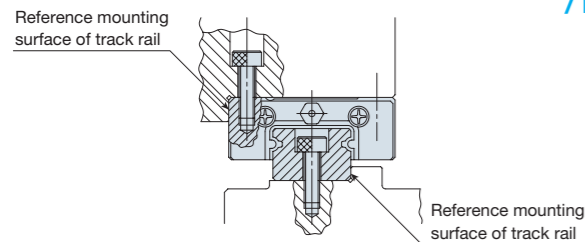

The reference mounting surface of track rail is made opposite to the standard side. The accuracy of dimension *N* including parallelism in operation is the same with that of standard specification.

## Specified track rail mounting hole positions

/E

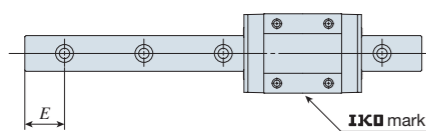

The mounting hole positions of track rail can be specified by specifying dimension *E* at the left end, which is the distance from the mounting hole nearest to the left end of the track rail to the left end face of the track rail in sight of IKO mark on the slide unit.

When ordering, add the dimension (in mm) after "/E". Dimension *E* can be specified in a limited range. Consult IKO for further information.

## With caps for rail mounting holes

(for ML, ME and MH series)

/F

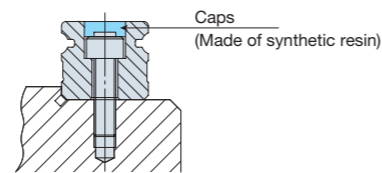

Specify prepared caps for track rail mounting holes are appended. These caps cover the track rail mounting holes to improve the sealing performance in the linear motion direction. Aluminum caps are also available. Consult IKO for further information.

## Ceramic ball specification

(for ML series)

/HB

Steel balls in the slide unit are changed to ceramic (silicon nitride) material.

Load ratings and static moment ratings are shown in Table 16.

Table 16 Load ratings and static moment ratings of ceramic ball specification C-Sleeve Linear Way ML

Model number	C N	C <sub>0</sub> N	T <sub>0</sub> N·m	T <sub>x</sub> <sup>(1)</sup> N·m	T <sub>y</sub> <sup>(1)</sup> N·m
MLC 7.../HB	937	965	3.5	1.6 12.6	1.3 10.6
ML 7.../HB	1 330	1 610	5.9	40 23.9	3.3 20.1
MLG 7.../HB	1 690	2 250	8.2	7.5 43.1	6.3 36.2
MLC 9.../HB	1 180	1 260	5.9	2.4 18.2	2.1 15.3
ML 9.../HB	1 810	2 340	10.9	7.7 43.4	6.6 36.4
MLG 9.../HB	2 370	3 420	15.9	15.9 83.6	13.4 70.1
MLC 12.../HB	2 210	2 030	12.6	4.5 35.5	3.8 29.8
ML 12.../HB	3 330	3 650	22.6	13.1 79.2	11 66.4
MLG 12.../HB	4 310	5 270	32.7	43 143	21.9 120
MLC 15.../HB	3 490	3 310	25.5	9.9 71.8	8.3 60.3
ML 15.../HB	4 980	5 520	42.5	25.3 146	21.2 122
MLG 15.../HB	6 620	8 280	63.7	54.3 288	45.5 241

Note<sup>(1)</sup>: The upper values in the T<sub>x</sub> and T<sub>y</sub> column apply to one slide unit, and the lower values apply to two slide units in close contact.

## With inspection sheet

/I

The inspection sheet recording dimensions *H* and *N* (See Accuracy), dimensional variations of *H* and *N*, and parallelism in operation of the slide unit is attached to each set.

## With female threads for bellows

(for ME and MH Interchangeable series) /J /JR /JL

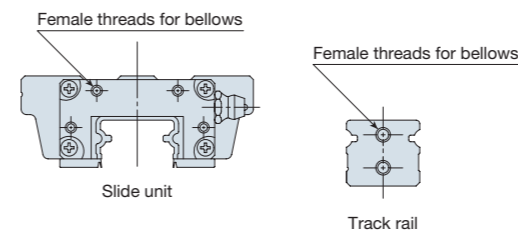

Female threads for mounting bellows are provided on the interchangeable slide unit or the interchangeable track rail of C-Sleeve Linear Way ME and MH series. For details of related dimensions, see Table 17.1 and 17.2.

- ① /J Female threads are provided at both ends of the slide unit or the track rail.
- ② /JR Female threads are provided at the right end of the slide unit in sight of IKO mark.
- ③ /JL Female threads are provided at the left end of the slide unit in sight of IKO mark.

## With female threads for bellows

(for assembled set of ME and MH series)

/J /JJ /JR /JS /JJS

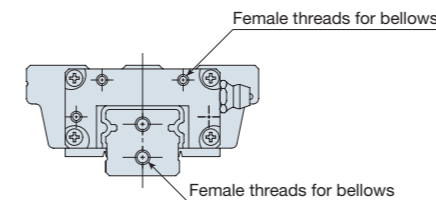

For an assembled set of interchangeable or non-interchangeable specification, female threads for mounting bellows are provided on the slide unit and the track rail. For the details of related dimensions, see Table 17.1 and 17.2.

- ① /J Female threads are provided at both ends of the track rail, and at the slide unit ends which are the closest to the track rail ends. (In case only one slide unit is assembled, female threads are provided at both ends.)
- ② /JJ Female threads are provided at both ends of the track rail, and at all ends of all slide units. (Applicable, when the number of slide units is two or more. In case only one slide unit is assembled, indicate "/J".)
- ③ /JR Female threads are provided at both ends of the track rail.
- ④ /JS Female threads are provided at the slide unit ends which are the closest to the track rail ends. (In case only one slide unit is assembled, female threads are provided at both ends.)
- ⑤ /JJS Female threads are provided at all ends of all slide units. (Applicable, when the number of slide units is two or more. In case only one slide unit is assembled, indicate "/JS".)

Table 17.1 C-Sleeve Linear Way ME Dimension of female threads for bellows

unit : mm

Model number	Slide unit							Track rail				
	a <sub>1</sub>	a <sub>2</sub>	b <sub>1</sub>	b <sub>2</sub>	b <sub>3</sub>	b <sub>4</sub>	M <sub>1</sub> × depth <sup>(2)</sup>	L <sub>1</sub>	H <sub>3</sub>	a <sub>3</sub>	a <sub>4</sub>	M <sub>2</sub> × depth
ME(T)C 15 <sup>(1)</sup>									58			
ME(T) 15 <sup>(1)</sup>									74			
ME(T)G 15 <sup>(1)</sup>									87			
MESC 15 <sup>(1)</sup>	3	12		16		28	M3 × 6		58	5.7	4	7 M3 × 6
MES 15 <sup>(1)</sup>			9		3				74			
MESG 15 <sup>(1)</sup>									87			
ME(T)C 20									64			
ME(T) 20					19.5	12.5			83			
ME(T)G 20									99			
MESC 20	3	15		20		34	M3 × 6		64	6	4	8 M3 × 6
MES 20									83			
MESG 20									99			
ME(T)C 25									76			
ME(T) 25					23.5	16.5			100			
ME(T)G 25									119			
MESC 25	3.5	17		26		40	M3 × 6		76	7	5	9 M4 × 8
MES 25									100			
MESG 25									119			
ME(T)C 30									83			
ME(T) 30						28	20		112			
ME(T)G 30									144			
MESC 30	5	17		34		50	M3 × 6		83	11	6	14 M4 × 8
MES 30									112			
MESG 30									144			
ME(T)C 35									93			
ME(T) 35						30	20		126			
MESC 35	6	20		40		60	M3 × 6		93	13	7	15 M4 × 8
MES 35									126			
ME(T) 45						35	23		138			
MES 45	7	26		50		74	M4 × 8		138	15	8	19 M5 × 10

Note<sup>(1)</sup>: The specification and mounting position of grease nipple are different from those of the standard specification product. Size 15 models are provided with a special specification grease nipple (NPB2 type). For details of dimension, consult IKO for further information.

<sup>(2)</sup>: The values are for the slide unit with female threads for bellows at both ends.

Remark: The table shows representative model numbers but is also applicable to stainless steel models.



Optional special specifications for use under special environment

Table 17.2 C-Sleeve Linear Way MH  
Dimension of female threads for bellows

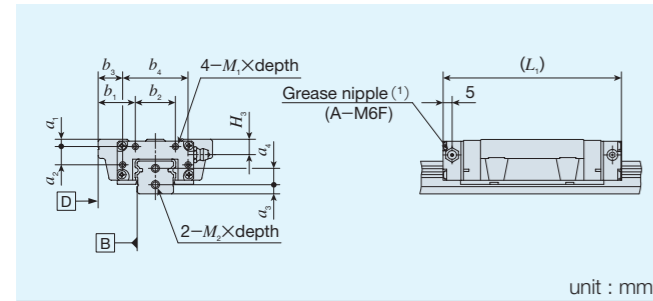

unit : mm

Model number	Slide unit										Track rail	
	a <sub>1</sub>	a <sub>2</sub>	b <sub>1</sub>	b <sub>2</sub>	b <sub>3</sub>	b <sub>4</sub>	M <sub>1</sub> × depth	L <sub>1</sub> <sup>(2)</sup>	H <sub>3</sub>	a <sub>3</sub>	a <sub>4</sub>	M <sub>2</sub> × depth
MH(T) 15 <sup>(1)</sup>	3		15.5	16	9.5				6.5			
MHD 15 <sup>(1)</sup>	7	7	9	16	3	28	M3 × 6	83	10.5	4	8	M3 × 6
MHS 15 <sup>(1)</sup>	3								6.5			
MH(T) 20			20.5	22	13.5				99			
MH(T)G20						36	M3 × 6	128	8.5	5	9	M4 × 8
MHS 20	4	10	11	22	4			99				
MHSG 20								128				
MH(T) 25	4		22	26	15			110	8.5			
MH(T)G25								133				
MHD 25	8	13				40	M3 × 6	110	12.5	5	12	M4 × 8
MHDG 25			11	26	4			133				
MHS 25	4							110	8.5			
MHSG 25								133				
MH(T) 30	5		28		20			128	11			
MH(T)G30								154				
MHD 30	8	17		34		50	M3 × 6	128	14	6	14	M4 × 8
MHDG 30								154				
MHS 30	5		13		5			128	11			
MHSG 30								154				
MH(T) 35	6		30		20			137	13			
MH(T)G35						60	M3 × 6	165		7	15	M4 × 8
MHD 35	13	20		40				137	20			
MHDG 35								165				
MH(T) 45	7		35		23			160	15			
MH(T)G45						74	M4 × 8	203		8	19	M5 × 10
MHD 45	17	26		50				160	25			
MHDG 45			18		6			203				

Note (1): The specification and the mounting position of grease nipple are different from those of the standard specification product. Size 15 models are provided with a special specification grease nipple (NPB2 type). For details of dimension, consult IKO for further information.

(2): The values are for the slide unit with female threads for bellows at both ends.

**Black chrome surface treatment**  
/LC /LR /LCR

A black permeable chrome film is formed to improve corrosion resistance.  
① /LC Treatment is applied to the casing.  
② /LR Treatment is applied to the track rail.  
③ /LCR Treatment is applied to the casing and the track rail.  
※For detail of applicability, see Table 6.1 to 6.4 on page 15 to 16.

**Fluorine black chrome surface treatment**  
(for ME and MH series)  
/LFC /LFR /LFCR

After forming a black permeable chrome film, the surface is coated with fluorine resin for further improvement in corrosion resistance. This treatment is also effective in preventing the adhesion of foreign substances on the surface.  
① /LFC Treatment is applied to the body of slide unit.  
② /LFR Treatment is applied to the track rail.  
③ /LFCR Treatment is applied to the body of slide unit and the track rail.  
※For detail of applicability, see Table 6.1 to 6.4 on page 15 to 16.

**With track rail mounting bolts**  
(for ME, MUL and set order of MH) /MA

Track rail mounting bolts are appended according to the number of mounting holes.

**Without track rail mounting bolts**  
(for ML and interchangeable track rail order of MH) /MN

Track rail mounting bolts are not appended.

**Change of mounting hole size and female threads size**  
(for ME15 and ME15...SL) /M4

The track rail mounting holes for M3 of ME15 is changed to M4. If "with track rail mounting bolts" is also required, specify /MA4.

**No end seal**  
(for ML, ME and MH series) /N

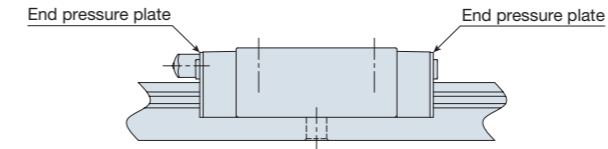

End rubber seals at both ends of slide unit are replaced by steel end pressure plates (not in contact with the track rail) to reduce frictional resistance. The under seals are not assembled. This specification is not effective for dust protection.

**Rail cover plate for track rail**  
(for non-interchangeable MH series) /PS

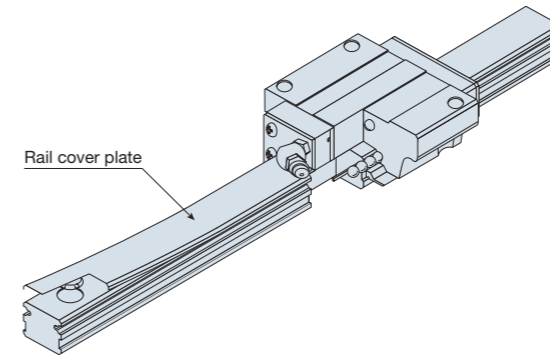

After mounting the track rail, the top surface of track rail is covered with a U-shaped thin stainless steel plate for further improvement in sealing performance. The rail cover plate is delivered as assembled on the track rail. Standard end seals must be replaced with the special end seals. When mounting the cover plate, refer to the attached instruction manual for rail cover plate.

**Track rail with stopper pins**  
(for non-interchangeable ML series) /S

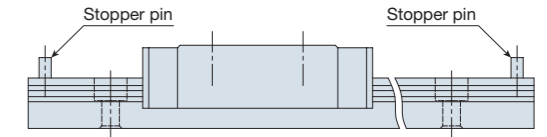

To prevent the slide unit of C-Sleeve Linear Way ML from slipping off of the track rail, a stopper pins are provided at both ends of the track rail. For related dimensions, see Table 18 below.

Table 18 C-Sleeve Linear Way ML  
Track rail with stopper pins (Supplemental code /S)

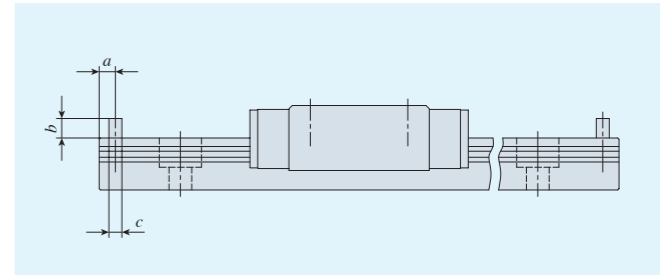

unit : mm

Model number	a	b	c	Model number	a	b	c
ML 5	2	2	1.6	MLF 10	2.5	2	1.6
ML 7	2.5	2.5	2	MLF 14		3	2
ML 9		3		MLF 18			
ML 12		3		MLF 24			
ML 15		4		MLF 30			
ML 20		5		MLF 42			
ML 25		3.5					

Remark : The table shows representative model numbers but is also applicable to all the models in the same size of ML and MLF series.

**Butt-jointing interchangeable track rail**  
(for interchangeable specification of ME and MH series) /T

A special interchangeable track rail of which both ends are finished for butt jointing in the direction of linear motion is provided. Use the track rails having the same interchangeable code for butt jointing. For the butt jointing for non-interchangeable specification, indicate butt-jointing track rail "/A".

Optional special specifications for use under special environment

**With under seals**

(for ML and ME series)

※ Under seals are attached to MH series as standard specification.

**/U**

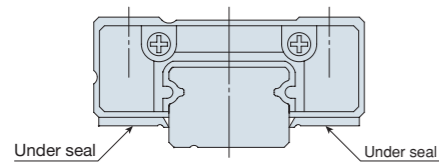

To prevent foreign substances intruding from the lower side of Linear Way, rubber seals are provided on the bottom faces of slide unit. For size  $H_1$ , see Table 19.

**Table 19**  $H_1$  dimension of slide unit with under seals (Supplemental code /U)

Model number	$H_1$
ML 9	1
ML 12	2
ML 15	3
ML 20	4
ML 25	5 <sup>(1)</sup>
MLF 18	2
MLF 24	
MLF 30	
MLF 42	3
ME 15	5
ME 20	
ME 25	
ME 30	6
ME 35	7
ME 45	8
MHT 8...SL	10
MHT 10...SL	1.5
MHT 12	1.8
MHT 12	3.2 <sup>(1)</sup>

Note (1):  $H_1$  dimension of ML25 and MHT12 models is the same as the dimension without under seals.

Remark: The table shows representative model numbers but is also applicable to all the models in the same size of ML, MLF, ME and MHT series.

**With upper seals**

(for MUL series)

**/U**

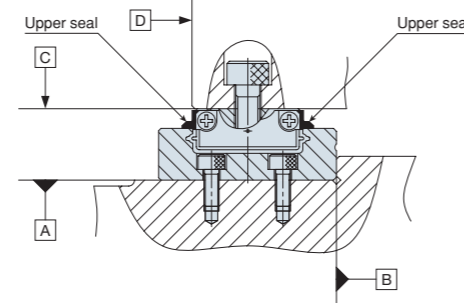

Rubber seals are attached to the upper side face of the slide unit to prevent foreign materials from entering from the upper side, so that the mounting reference surface  $\square$  cannot be used. Table 20 shows sizes of the slide unit when upper seals are attached.

**Table 20** Dimension of the slide unit with upper seals (Supplemental code /U)

Model number	$N$	$W_2$
MUL 25	21.4	18
MUL 30	25.9	22

**With double end seals**

(for interchangeable single slide unit of ME and MH series)

**/V /VR /VL**

Double rubber end seals are provided on the interchangeable slide unit for more effective dust protection. For the total length of the slide unit with double end seals, see the Table 18.

- ① /V Double end seals are provided at both ends of the slide unit.
- ② /VR Double end seals are provided at the right end of the slide unit in sight of mark.
- ③ /VL Double end seals are provided at the left end of the slide unit in sight of mark.

**With double end seals**

(for assembled set of ME and MH series)

**/V /VV**

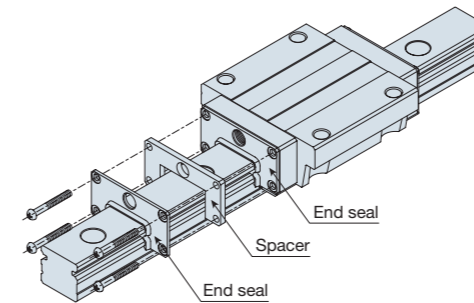

Double end seals are provided on the slide unit of assembled set of interchangeable specification or non-interchangeable specification for more effective dust protection. For the total length of the slide unit with double end seals, see the Table 21.

- ① /V Double end seals are provided at the ends of slide units which are the closest to the ends of the track rail. (In case only one slide unit is assembled, double end seals are provided at both ends.)
- ② /VV Double end seals are provided at all ends of all slide units. (Applicable when the number of slide units is two or more. In case only one slide unit is assembled, indicate "/V".)

**Matched sets to be used as an assembled group**

(Applicable to non-interchangeable spec.)

**/W**

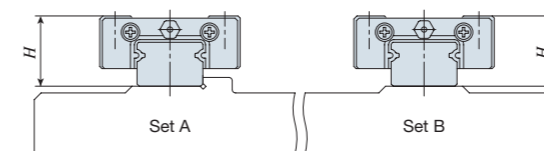

For two or more sets of C-Sleeve Linear Way used on the same plane, the dimensional variation of  $H$  of C-Sleeve Linear Way is kept within the specified range. The dimensional variation of dimension  $H$  in matched sets is the same as that of a single set. Indicate the number of sets after "/W". (Ex: ML9C2R160H/W2)

**Table 21** Dimension of the slide unit with double end seals (Supplemental code /VV)

Model number	$L_1$ <sup>(1)</sup>	$L_2$	Model number	$L_1$ <sup>(1)</sup>	$L_2$
MEC 15	48	50	MH 15	72	77
ME 15	64	66	MH 20	91	104
MEG 15	76	78	MHG 20	119	133
MEC 20	54	68	MH 25	104	116
ME 20	73	87	MHG 25	127	139
MEG 20	89	103	MH 30	122	134
MEC 25	67	80	MHG 30	148	160
ME 25	91	104	MH 35	133	146
MEG 25	110	123	MHG 35	161	173
MEC 30	78	89	MH 45	159	170
ME 30	107	118	MHG 45	202	213
MEG 30	138	150			
MEC 35	88	101			
ME 35	121	134			
ME 45	137	148			

Note (1): The values are the slide unit with double end seals at both ends. Remark: The table shows representative model numbers but is also applicable to all the models in the same size of ME and MH series.

**With scrapers**

(for interchangeable single slide unit of ME and MH series)

**/Z /ZR /ZL**

Metal scrapers are provided on the slide unit of interchangeable specification. The scraper (non-contact type) is used to effectively remove large particles of dust or foreign matter adhering to the track rail. For the total length of the slide unit with scrapers, see Table 22.

- ① /Z Scrapers are provided at both ends of the slide unit.
- ② /ZR A scraper is provided at the right end of the slide unit in sight of mark.
- ③ /ZL A scraper is provided at the left end of the slide unit in sight of mark.



Optional special specifications for use under special environment

**With scrapers**  
(for assembled set of ME and MH series)

/Z /ZZ

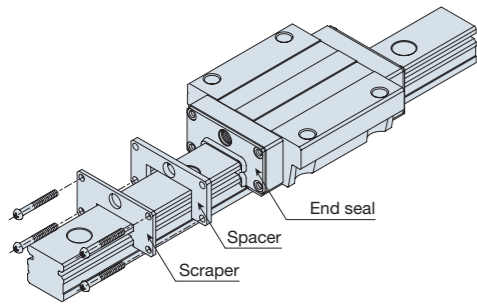

Metal scrapers are provided on the slide units of assembled set of interchangeable specification or non-interchangeable specification.

Scrapers (non-contact type) are used to effectively remove large particles of dust or foreign matter adhering to the track rail. For the total length of the slide unit with scrapers, see Table 22.

- ① /Z Scrapers are provided at the ends of slide units which are the closest to the ends of the track rail. (In case only one slide unit is assembled, scrapers are provided at both ends.)
- ② /ZZ Scrapers are provided at all ends of all slide units. (Applicable when the number of slide units is two or more. In case only one slide unit is assembled, indicate "/Z".)

**Table 22 Dimension of the slide unit with scrapers**  
(Supplemental code /Z /ZZ)

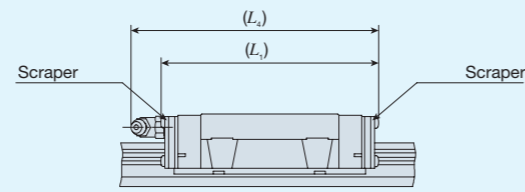

unit : mm

Model number	$L_1$ (1)	$L_2$	Model number	$L_1$ (1)	$L_2$
MEC 15	48	50	MH 15	73	75
ME 15	64	66	MH 20	91	104
MEG 15	77	79	MHG 20	119	133
MEC 20	55	69	MH 25	104	116
ME 20	75	88	MHG 25	126	139
MEG 20	90	104	MH 30	124	135
MEC 25	69	81	MHG 30	150	161
ME 25	93	105	MH 35	133	146
MEG 25	112	124	MHG 35	161	174
MEC 30	79	90	MH 45	160	171
ME 30	108	119	MHG 45	203	214
MEG 30	140	151			
MEC 35	89	101			
ME 35	122	134			
ME 45	138	148			

Note (1) : The values are the slide unit lengths with scrapers at both ends.  
Remark : The table shows representative model numbers but is also applicable to all the models in the same size of ME and MH series.

**Lubrication and Dust protection**

Lithium-soap base grease (MULTEMP PS No.2 : KYODO YUSHI) is pre-packed in C-Sleeve Linear Way ML and lithium-soap base grease containing extreme pressure additive (ALVANIA grease EP 2: SHELL) is pre-packed C-Sleeve Linear Way ME, MH and MUL. Additionally, C-Sleeve (Capillary sleeve) a component part is placed in the ball recirculation path, thereby extending the re-lubrication (greasing) interval time and maintenance work for a long period.

C-Sleeve Linear Way is provided with an oil hole and with grease nipple shown in Table 23 and 24. Supply nozzles matching the size of grease nipple are available. For these parts for lubrication, consult IKO for further information.

C-Sleeve Linear Way is dust protected with special rubber seals. But, if large amount of fine contaminants may present, or if large particles of foreign matter such as dust or chips may fall on the track rail, it is recommended to provide protective covers such as bellows for the entire linear motion mechanism. Bellows to match the dimensions of C-Sleeve Linear Way are optionally available. They are easy to mount and highly effective for dust protection. If required, consult IKO.

**Table 23 Oil hole**

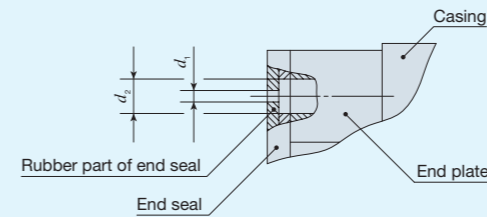

unit : mm

Model number	Dimension of oil hole	
	$d_1$	$d_2$
ML 5	0.5	1.1
ML 7		1.2
ML 9		1.5
ML 12		2
MLF 10		1.1
MLF 14		1.2
MLF 18		1.5
MLF 24		2
MHT 8...SL		1.5
MHT 10...SL		1.5
MUL 25	1.2	
MUL 30	1.5	

Remark : The table shows representative model numbers but is also applicable to all the models in the same size.

**Table 24 Grease nipple**

unit : mm

Model number	Type	Grease nipple
		Shape and dimension
ML 15 ML 20 MLF 30 MLF 42 MHT 12	A-M3	
ML 25	B-M4	
ME 15 MH 15	A-M4	
ME 20 ME 25 ME 30 MH 20 MH 25 MH 30	B-M6	
ME 35 ME 45 MH 35 MH 45	JIS B type	

Remark : The table shows representative model numbers but is also applicable to all the models in the same size.

# Precautions for use

## 1 Mounting surface, reference mounting surface, and general mounting structure

To mount C-Sleeve linear way, correctly fit the reference mounting surfaces B and D of the slide unit and track rail to the reference mounting surfaces of the table and the bed, and then fix them tightly. (See Fig.4.1 and 4.2)

The reference mounting surfaces B and D and the mounting surfaces A and C of C-Sleeve Linear Way are accurately finished by grinding. Stable and high accuracy liner motion can be obtained by finishing the mating mounting surfaces of machines or equipment with high accuracy and correctly mounting the guide on these surfaces.

The slide unit reference mounting surface is always the side surface opposite to the IKO mark. The track rail reference mounting surface is identified by locating the IKO mark on the top surface of the track rail. The track rail reference mounting surface is the side surface above the IKO mark (in the direction of the arrow). (See Fig.5.1 and 5.2)

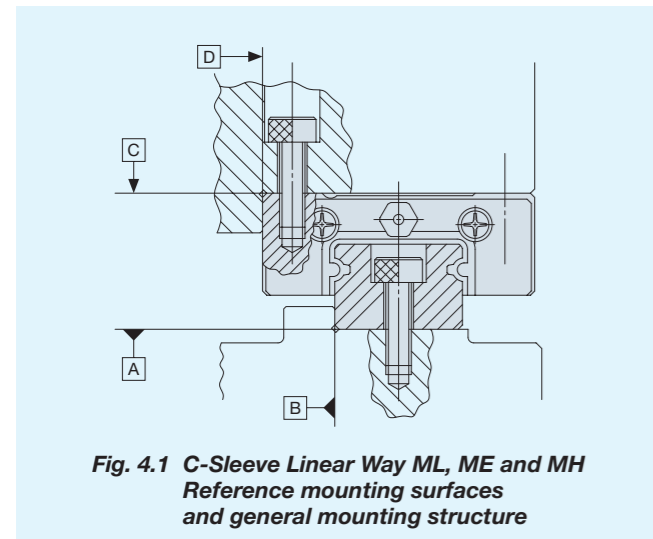

Fig. 4.1 C-Sleeve Linear Way ML, ME and MH Reference mounting surfaces and general mounting structure

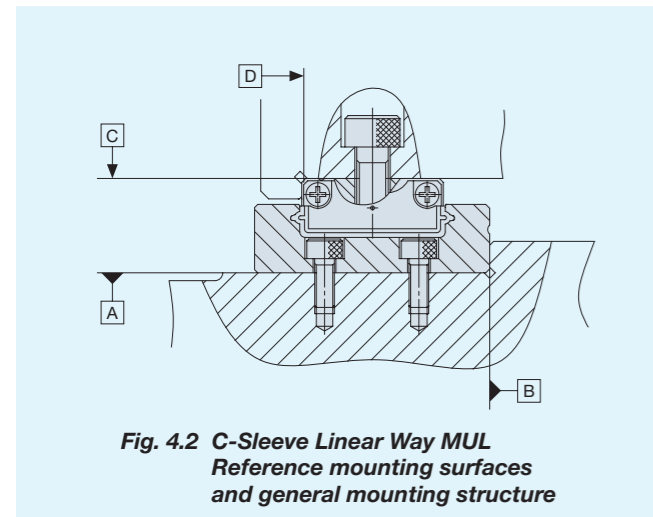

Fig. 4.2 C-Sleeve Linear Way MUL Reference mounting surfaces and general mounting structure

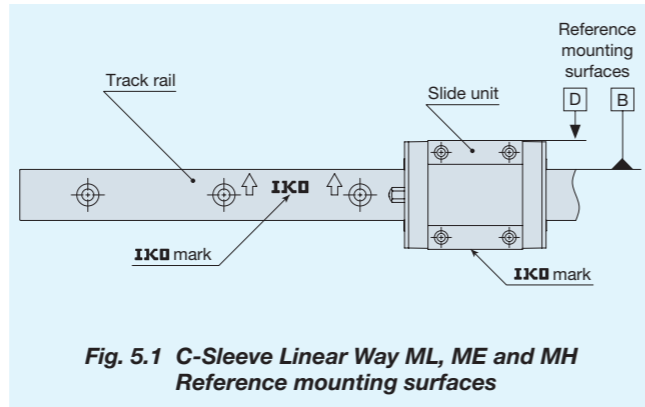

Fig. 5.1 C-Sleeve Linear Way ML, ME and MH Reference mounting surfaces

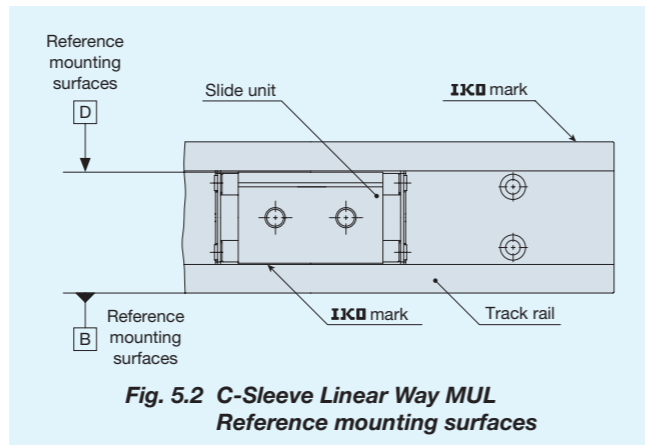

Fig. 5.2 C-Sleeve Linear Way MUL Reference mounting surfaces

## 2 Corner radius and shoulder height of reference mounting surfaces

It is recommended to make a relieved fillet at the corner of the mating reference mounting surfaces as shown in Fig.6. Otherwise, corner radius  $R_1$  and  $R_2$  are recommended shown in Table 25.1 and 25.2. Table 25.1 and 25.2 shows recommended shoulder heights and radius of the reference mounting surfaces.

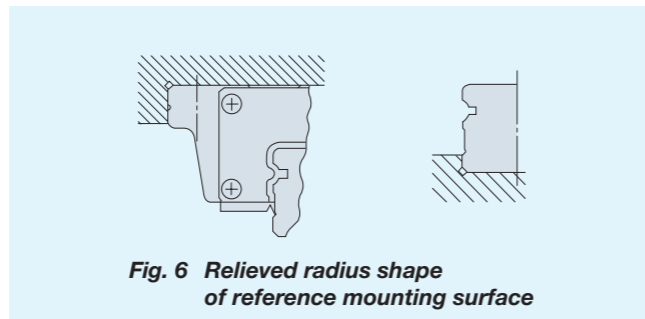

Fig. 6 Relieved radius shape of reference mounting surface

Table 25.1 C-Sleeve Linear Way ML and ME Shoulder height and radius of the reference mounting surfaces

Model number	Slide unit		Track rail	
	Shoulder height $h_1$	Relieved radius $R_1$ (max.)	Shoulder height $h_2$	Relieved radius $R_2$ (max.)
ML 5	2	0.3	0.8	0.2
ML 7	2.5	0.2	1.2	
ML 9	3		1.5 <sup>(1)</sup>	
ML 12	4		2.5 <sup>(2)</sup>	
ML 15	4.5		3 <sup>(2)</sup>	
ML 20	5		0.7	4 <sup>(2)</sup>
ML 25	6.5	0.7		
MLF 10	2	0.3	1.2	0.2
MLF 14	2.5	0.2	1.2	
MLF 18	3			
MLF 24	4			
MLF 30	4.5			
MLF 42	5			
ME(T) 15	4	1	3	0.5
MES 15		0.5		
ME(T) 20	5	1	4	1
MES 20		0.5		
ME(T) 25	6	1	5	1
MES 25				
ME(T) 30	8	1.5	6	1
MES 30				
ME(T) 35	8	1.5	7	1.5
MES 35				
ME(T) 45	8	1.5	7	1.5
MES 45				

Note (1) : For "with under seals" of the size 9 models, 0.8mm is recommended.  
 (2) : For "with under seals" (supplemental code "/U"), it is recommended to use a value obtained by subtracting 1mm from the value  $h_2$  shown in the table.  
 Remark : The table shows representative model numbers but is also applicable to all the models in the same size.

Table 25.2 C-Sleeve Linear Way MH and MUL Shoulder height and radius of the reference mounting surfaces

Model number	Slide unit		Track rail	
	Shoulder height $h_1$	Relieved radius $R_1$ (max.)	Shoulder height $h_2$	Relieved radius $R_2$ (max.)
MHT 8 ...SL	3.5	0.5	1.6 <sup>(1)</sup>	0.2
MHD 8 ...SL	4		1.9 <sup>(1)</sup>	
MHT 10 ...SL	4.5			
MHD 10 ...SL	5		2.7 <sup>(1)</sup>	0.7
MHT 12	6		3	0.5
MHD 12	6			
MH 15	4	4	1	
MH 20	5			
MH 25	6	5	1	
MH 30	8			
MH 35	8	1.5	7	1.5
MH 45	8			
MUL 25	1.5	0.2	2.5	-
MUL 30	2.5		3	-

Note (1) : For "with under seals" (supplemental code "/U"), it is recommended to use a value obtained by subtracting 0.6mm from the value  $h_2$  shown in the table.  
 Remark : The table shows representative model numbers but is also applicable to all the models in the same size.

## 3 Multiple slide units mounted in close distance

When using multiple slide units in close distance to each other, actual load may be greater than the calculated load depending on the mounting accuracy of the slide units on the mounting surfaces and the reference mounting surfaces of the machine. It is suggested in such cases to assume a greater load than the calculated load.

## 4 Operating temperature

The C-Sleeve Linear Way must be used under 80°C (maximum).

## 5 Cleaning

Do not wash C-Sleeve Linear Way with organic solvent and/or white kerosene, which have the ability of removing fat nor leave them in contact with the above agents.



## Mounting

### 1 Assembling two or more sets of C-Sleeve Linear Way

#### • Interchangeable specification

In the case of an interchangeable specification product, assemble a slide unit and a track rail with the same interchangeable code. ("S2" slide unit + "S2" track rail)

#### • Non-interchangeable specification

Use an assembly of slide unit and track rail as delivered without changing the combination.

#### • Matched sets to be used as an assembled group

Special specification products of matched sets (by supplemental code "/W") are delivered as a group in which dimensional variations are specially controlled. Mount them without mixing with the sets of another group.

### 2 Assembling a slide unit and a track rail

When assembling C-Sleeve Linear Way, correctly fit the slide unit mounted on a steel ball holder to the groove of the track rail, and then move the slide unit gently from the steel ball holder to the track rail in parallel direction.

Steel balls are retained in C-Sleeve Linear Way, so the slide unit can be separated freely from the track rail. However, the slide unit can be assembled on the track rail much easier by using the steel ball holder.

Steel ball holder is appended as an accessory to the interchangeable slide unit of C-Sleeve Linear Way ML as shown in Table 26. The steel ball holder for another models is also available. If required, consult  for further information.

**Table 26 C-Sleeve Linear Way ML and MH Models to which a steel ball holder is appended**

C-Sleeve Linear Way ML		C-Sleeve Linear Way MH	
ML (C) 5	MLF (C) 10	MHT 8...SL	
ML (C, G) 7	MLF (C, G) 14	MHT 10...SL	
ML (C, G) 9	MLF (C, G) 18	MHT 12...SL	
MLG 12	MLFG 24	MHD (C, G) 8...SL	
MLG 15	MLFG 30	MHD (C, G) 10...SL	
MLG 20	MLFG 42	MHD (C, G) 12...SL	
MLG 25	—	MHT 12	
—	—	MHD 12	

### 3 Working precision of mounting surfaces

Inadequate mounting accuracy of C-Sleeve Linear Way will affect the operating accuracy and life adversely, so mounting must be carried out with care. When multiple sets are mounted, the parallelism between the two mounting surfaces of machines must be prepared, in general, as shown in Table 27. If mounting parallelism is poor, frictional resistance will steeply increase giving a warning signal, which can be used to perform high accuracy mounting.

**Table 27 Parallelism between two mounting surfaces**

unit :  $\mu\text{m}$

Class	Ordinary (No symbol)	High (H)	Precision (P)	Super precision (SP)
Parallelism	30		20	10

### 4 Cleaning the mounting surfaces

When mounting C-Sleeve Linear Way, first clean all mounting and reference mounting surfaces. (See Fig.7)

Remove burrs and blemishes from the reference mounting surfaces and mounting surfaces of the machine using an oil-stone, etc., and then wipe the surfaces with clean cloth.

Remove rust preventive oil and dirt from the reference mounting surfaces and mounting surfaces with clean cloth.

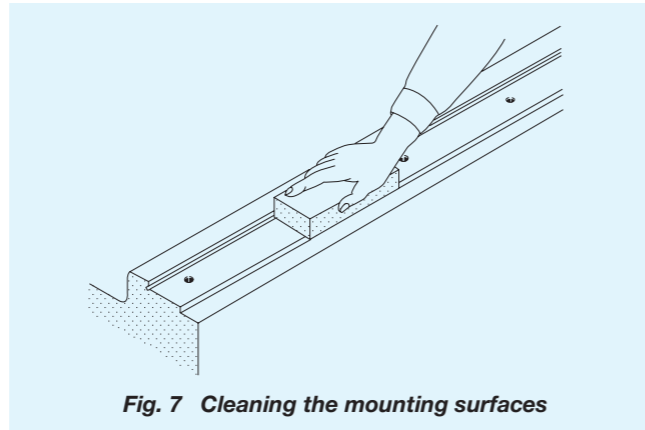

**Fig. 7 Cleaning the mounting surfaces**

### 5 Plugging-in of caps for rail mounting holes

When plugging the caps for rail mounting holes (supplemental code "/F") into the mounting holes of track rail, tap in the cap gently by applying a flat plate on the top face of the cap until the top face of the cap becomes level with the top face of the track rail.

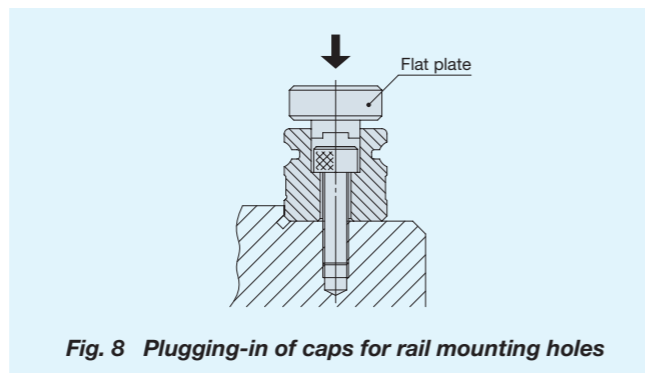

**Fig. 8 Plugging-in of caps for rail mounting holes**

### 6 Tightening torque of mounting bolts

The standard torque values for C-Sleeve Linear Way mounting bolts are shown in Table 28.1 and 28.2. When machines or equipment are subjected to serve vibration, shock, large fluctuating load, or moment load, the bolts should be tightened with a torque 1.2 to 1.5 times higher than the standard torque values shown. When the mating member material is cast iron or aluminum, tightening torque should be lowered in accordance with the strength characteristics of the material.

**Table 28.1 C-Sleeve Linear Way ME and MH Tightening torque of mounting bolts**

Bolt size	Tightening torque N·m
	Carbon steel bolt (Strength division 12.9)
M3 × 0.5	1.7
M4 × 0.7	4.0
M5 × 0.8	7.9
M6 × 1	13.3
M8 × 1.25	32.0

**Table 28.2 C-Sleeve Linear Way ML, MH (size 8, 10 and 12) and MUL Tightening torque of mounting bolts**

Bolt size	Tightening torque N·m	
	Carbon steel bolt (Strength division 12.9)	Stainless steel bolt (Property division A2-70)
M2 × 0.4	—	0.31
M2.5 × 0.45	—	0.62
M3 × 0.5	1.2	1.1
M4 × 0.7	—	2.5
M5 × 0.8	—	5.0
M6 × 1.0	—	8.5

## Track rail lengths

Standard and maximum lengths of track rails are shown in Table 29.1 to 29.5.

Track rail in any length are also available. Simply indicate the necessary length of track rail in millimeter (mm) in the identification number. For the tolerance of  $E$  dimension and Track rail length, consult  for further information.

• In non-interchangeable specification, for track rail longer than the maximum length shown in Table 29.1 to 29.5, butt-jointing track rails are available upon request. In this case, indicate supplemental code "/A" in the identification number.

•  $E$  dimensions at both ends are the same unless otherwise specified. To change these dimensions, specify the specified rail mounting hole positions (supplemental code "/E") of special specification.

**Table 29.1 C-Sleeve Linear Way ML (standard type) Standard and maximum lengths of track rails**

Item	Model number	ML 5	ML 7	ML 9	ML 12	ML 15	ML 20	ML 25
		Standard length $L(n)$	60 ( 4) 90 ( 6) 105 ( 7) 120 ( 8) 150 (10)	60 ( 4) 90 ( 6) 120 ( 8) 150 (10) 180 (12) 240 (16)	60 ( 3) 80 ( 4) 120 ( 6) 160 ( 8) 220 (11) 280 (14)	100 ( 4) 150 ( 6) 200 ( 8) 275 (11) 350 (14) 475 (19)	160 ( 4) 240 ( 6) 320 ( 8) 440 (11) 560 (14) 680 (17)	180 ( 3) 240 ( 4) 360 ( 6) 480 ( 8) 660 (11) 840 (14)
Mounting hole pitch $F$		15	15	20	25	40	60	60
$E$		7.5	7.5	10	12.5	20	30	30
Reference dimension $E$ (1)	Over (Incl.)	4	4.5	4.5	5	5.5	8	9
	Under	11.5	12	14.5	17.5	25.5	38	39
Maximum length (2)		210 (510)	300 (990)	860 (1 200)	1 000 (1 450)	1 000 (1 480)	960 (1 800)	960 (1 800)
Maximum number of track rails for butt jointing		5	7	2	2	2	2	2
Maximum length of butt jointing track rails		915	1 905	1 660	1 925	1 880	1 740	1 740

unit : mm

Note (1) : Not applied to optional specification "track rail stopper pins" (supplemental code "/S").

(2) : The track rails can be manufactured up to the maximum length shown in parentheses. If required, please consult  for further information.

Remark : The table shows representative model numbers but is also applicable to all the models in the same size.

Track rail lengths

**Table 29.2 C-Sleeve Linear Way MLF (wide type)**  
Standard and maximum lengths of track rails

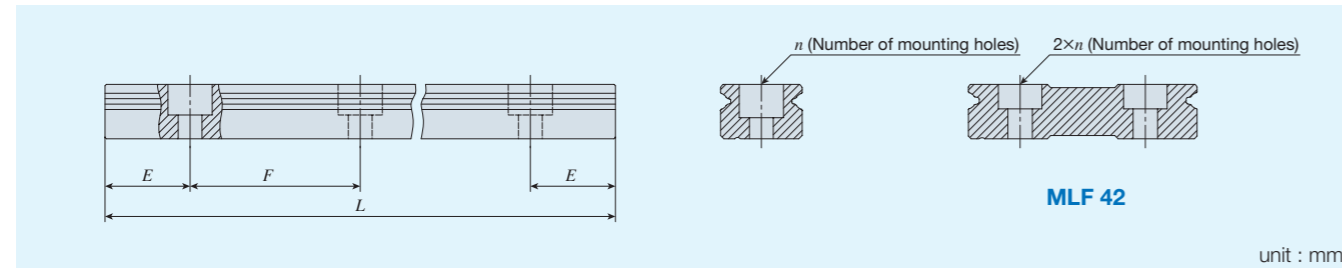

Item	Model number	MLF 10	MLF 14	MLF 18	MLF 24	MLF 30	MLF 42
Standard length $L(n)$		60 ( 3)	90 ( 3)	90 ( 3)	120 ( 3)	160 ( 4)	160 ( 4)
		80 ( 4)	120 ( 4)	120 ( 4)	160 ( 4)	240 ( 6)	240 ( 6)
		120 ( 6)	150 ( 5)	150 ( 5)	240 ( 6)	320 ( 8)	320 ( 8)
		160 ( 8)	180 ( 6)	180 ( 6)	320 ( 8)	440 (11)	440 (11)
		220 (11)	240 ( 8)	240 ( 8)	400 (10)	560 (14)	560 (14)
	280 (14)	300 (10)	300 (10)	480 (12)	680 (17)	680 (17)	
Mounting hole pitch $F$		20	30	30	40	40	40
$E$		10	15	15	20	20	20
Reference dimension $E^{(1)}$	Over (Incl.)	4.5	5.5	5.5	6.5	6.5	6.5
	Under	14.5	20.5	20.5	26.5	26.5	26.5
Maximum length $^{(2)}$		300 (500)	300 (990)	690 (1 860)	680 (1 960)	680 (2 000)	680 (2 000)
Maximum number of track rails for butt jointing		7	8	3	3	3	3
Maximum length of butt jointing track rails		1 840	1 950	1 920	1 840	1 840	1 840

Note (1) : Not applied to optional specification "track rail stopper pins" (supplemental code "S").  
 (2) : The track rails can be manufactured up to the maximum length shown in parentheses. If required, please consult IKO for further information.  
 Remark : The table shows representative model numbers but is also applicable to all the models in the same size.

**Table 29.3 C-Sleeve Linear Way ME**  
Standard and maximum lengths of track rails

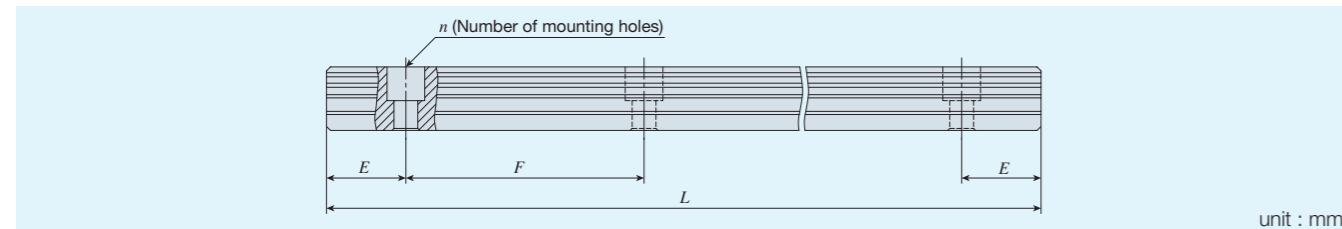

Item	Model number	ME 15	ME 20	ME 25	ME 30	ME 35	ME 45	ME15...SL	ME20...SL	ME25...SL	ME30...SL
Standard length $L(n)$		160 ( 3)	220 ( 4)	220 ( 4)	280 ( 4)	280 ( 4)	570 ( 6)	160 ( 3)	220 ( 4)	220 ( 4)	280 ( 4)
		220 ( 4)	280 ( 5)	280 ( 5)	440 ( 6)	440 ( 6)	885 ( 9)	220 ( 4)	280 ( 5)	280 ( 5)	440 ( 6)
		280 ( 5)	340 ( 6)	340 ( 6)	600 ( 8)	600 ( 8)	1 200 (12)	280 ( 5)	340 ( 6)	340 ( 6)	600 ( 8)
		340 ( 6)	460 ( 8)	460 ( 8)	760 (10)	760 (10)	1 620 (16)	340 ( 6)	460 ( 8)	460 ( 8)	760 (10)
		460 ( 8)	640 (11)	640 (11)	1 000 (13)	1 000 (13)	2 040 (20)	460 ( 8)	640 (11)	640 (11)	1 000 (13)
		640 (11)	820 (14)	820 (14)	1 240 (16)	1 240 (16)	2 460 (24)	640 (11)	820 (14)	820 (14)	1 240 (16)
		820 (14)	1 000 (17)	1 000 (17)	1 640 (21)	1 640 (21)	2 985 (29)	820 (14)	1 000 (17)	1 000 (17)	1 640 (21)
			1 240 (21)	1 240 (21)	2 040 (26)	2 040 (26)					
Mounting hole pitch $F$		60	60	60	80	80	105	60	60	60	80
$E^{(1)}$		20	20	20	20	20	22.5	20	20	20	20
Reference dimension $E^{(2)}$	Over (Incl.)	6	8	9	9	10	12	6	8	9	9
	Under	36	38	39	49	50	64.5	36	38	39	49
Maximum length $^{(3)(4)}$		1 600 (2 980)	2 200 (2 980)	2 980 (4 000)	3 000 (3 960)	3 000 (3 960)	2 985 (3 930)	1 200 (1 600)	1 200 (1 960)	1 200 (1 960)	1 200 (1 960)

Note (1) : When specifying a butt-jointing interchangeable track rail (supplemental code "T"), pay attention to the  $E$  dimension at the butt-jointing part.  
 (2) : Not applicable to the track rail with female threads for bellows (Supplemental code /J).  
 (3) : The dimension "E" of stainless steel product is the half value of dimension "F".  
 (4) : The track rails can be manufactured up to the maximum length shown in parentheses. If required, please consult IKO for further information.  
 Remark : The table shows representative model numbers but is also applicable to all the models in the same size.

**Table 29.4 C-Sleeve Linear Way MH**  
Standard and maximum lengths of track rails

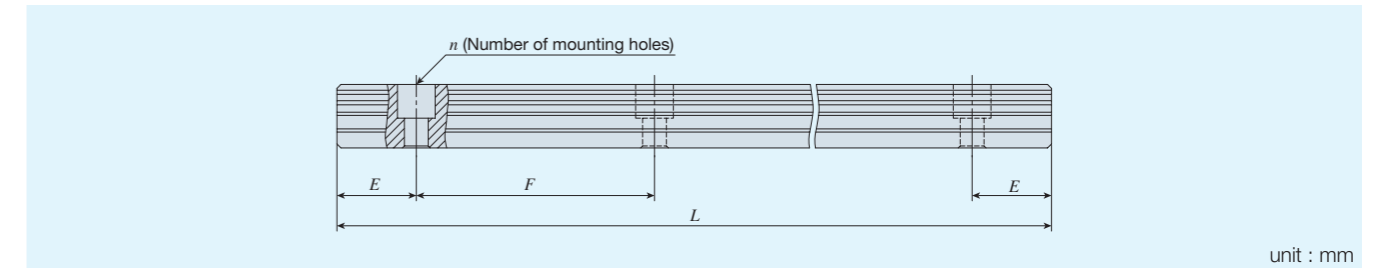

Item	Model number	MH 12	MH 15	MH 20	MH 25	MH 30	MH 35	MH 45	MH 8...SL	MH10...SL	MH12...SL
Standard length $L(n)$		80 ( 2)	180 ( 3)	240 ( 4)	240 ( 4)	480 ( 6)	480 ( 6)	840 ( 8)	40 ( 2)	50 ( 2)	80 ( 2)
		160 ( 4)	240 ( 4)	480 ( 8)	480 ( 8)	640 ( 8)	640 ( 8)	1 050 (10)	80 ( 4)	100 ( 4)	160 ( 4)
		240 ( 6)	360 ( 6)	660 (11)	660 (11)	800 (10)	800 (10)	1 260 (12)	120 ( 6)	150 ( 6)	240 ( 6)
		320 ( 8)	480 ( 8)	840 (14)	840 (14)	1 040 (13)	1 040 (13)	1 470 (14)	160 ( 8)	200 ( 8)	320 ( 8)
		400 (10)	660 (11)	1 020 (17)	1 020 (17)	1 200 (15)	1 200 (15)	1 995 (19)	200 (10)	250 (10)	400 (10)
		480 (12)	900 (15)	1 200 (20)	1 200 (20)	1 520 (19)	1 520 (19)		240 (12)	300 (12)	480 (12)
		560 (14)	1 200 (20)	1 500 (25)	1 500 (25)	2 000 (25)			280 (14)	350 (14)	560 (14)
		640 (16)			1 980 (33)					400 (16)	640 (16)
		720 (18)								450 (18)	720 (18)
										500 (20)	
Mounting hole pitch $F$		40	60	60	60	80	80	105	20	25	40
$E$		20	30	30	30	40	40	52.5	10	12.5	20
Reference dimension $E^{(1)}$	Over (Incl.)	5.5	7	8	9	10	10	12.5	4.5	5	5.5
	Under	25.5	37	38	39	50	50	65	14.5	17.5	25.5
Maximum length $^{(2)}$		1 480	1 500 (3 000)	1 980 (3 000)	3 000 (3 960)	2 960 (4 000)	2 960 (4 000)	2 940 (3 990)	480 (1 000)	850 (1 000)	1 000 (1 480)

Note (1) : Not applicable to the track rail with female threads for bellows (Supplemental code /J).  
 (2) : The track rails can be manufactured up to the maximum length shown in parentheses. If required, please consult IKO for further information.  
 Remark : The table shows representative model numbers but is also applicable to all the models in the same size.

**Table 29.5 C-Sleeve Linear Way MUL**  
Standard and maximum lengths of track rails

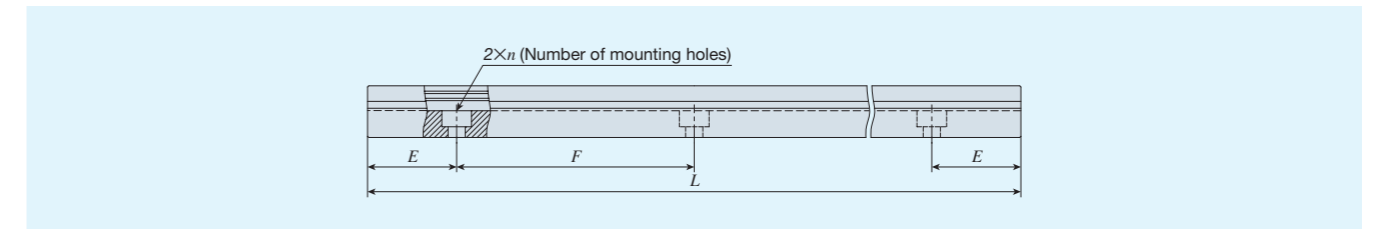

Item	Model number	MUL 25	MUL 30
Standard length $L(n)$		105 (3)	120 (3)
		140 (4)	160 (4)
		175 (5)	200 (5)
		210 (6)	240 (6)
		245 (7)	280 (7)
	280 (8)	320 (8)	
Mounting hole pitch $F$		35	40
$E$		17.5	20
Reference dimension $E^{(1)}$	Over (Incl.)	4.5	4.5
	Under	22	24.5
Maximum length $^{(1)}$		420 (840)	480 (960)

Note (1) : The track rails can be supplied with up to the length shown in parentheses as maximum. If required, please consult IKO for further information.



# IKO G-Sleeve Linear Way ML Standard type

MLC · ML · MLG

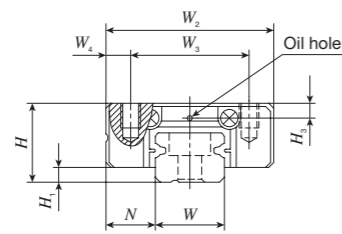

MLC 5 ~ MLC 12  
ML 5 ~ ML 12  
MLG 7 ~ MLG 12

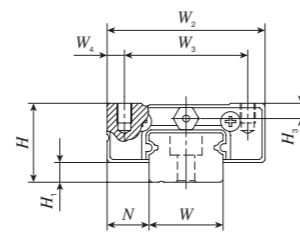

MLC 15 ~ MLC 25  
ML 15 ~ ML 25  
MLG 15 ~ MLG 25

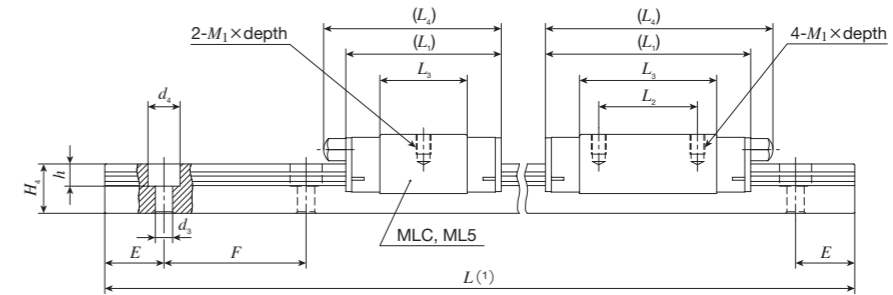

Model number	Interchangeable	Mass (Reference) g		Dimension of assembly mm			Dimension of slide unit mm							Dimension of track rail mm						Appended mounting bolt for track rail mm Bolt size x length	Basic dynamic load rating C	Basic static load rating C <sub>0</sub>	Static moment rating <sup>(2)</sup>			Model number			
		Slide unit	Track rail (per 100mm)	H	H <sub>1</sub>	N	W <sub>2</sub>	W <sub>3</sub>	W <sub>4</sub>	L <sub>1</sub>	L <sub>2</sub>	L <sub>3</sub>	L <sub>4</sub>	M <sub>1</sub> x depth	H <sub>3</sub>	W	H <sub>4</sub>	d <sub>3</sub>	d <sub>4</sub>				h	E	F		T <sub>0</sub>	T <sub>x</sub>	T <sub>y</sub>
MLC 5	☆	3.4	12	6	1	3.5	12	8	2	16	-	9.6	-	M2 x 1.5	1.2	5	3.7	2.4	3.6	0.8	7.5	15	Cross-recessed head screw for precision equipment M2 x 6	562	841	2.2	1.4	1.2	MLC 5
ML 5	☆	4.3		6	1	3.5	12	8	2	19	-	12.6	-	M2 x 1.5	1.2	5	3.7	2.4	3.6	0.8	7.5	15	Cross-recessed head screw for precision equipment M2 x 6	676	1 090	2.9	2.3	1.9	ML 5
MLC 7	☆	6.7	22	8	1.5	5	17	12	2.5	19	-	9.6	-	M2 x 2.5	1.5	7	5	2.4	4.2	2.3	7.5	15	Hexagon socket head bolt M2 x 6	937	1 140	4.1	1.8	1.5	MLC 7
ML 7	☆	9.1		8	1.5	5	17	12	2.5	23.5	8	14.3	-	M2 x 2.5	1.5	7	5	2.4	4.2	2.3	7.5	15	Hexagon socket head bolt M2 x 6	1 330	1 890	6.9	4.7	3.9	ML 7
MLG 7	☆	13		8	1.5	5	17	12	2.5	31	12	21.6	-	M2 x 2.5	1.5	7	5	2.4	4.2	2.3	7.5	15	Hexagon socket head bolt M2 x 6	1 690	2 650	9.7	8.8	7.4	MLG 7
MLC 9	☆	11	35	10	2	5.5	20	15	2.5	21.5	-	11.9	-	M3 x 3	2.2	9	6	3.5	6	3.5	10	20	Hexagon socket head bolt M3 x 8	1 180	1 480	6.9	2.9	2.4	MLC 9
ML 9	☆	18		10	2	5.5	20	15	2.5	30	10	20.8	-	M3 x 3	2.2	9	6	3.5	6	3.5	10	20	Hexagon socket head bolt M3 x 8	1 810	2 760	12.8	9.1	7.6	ML 9
MLG 9	☆	26		10	2	5.5	20	15	2.5	40.5	15	30.9	-	M3 x 3	2.2	9	6	3.5	6	3.5	10	20	Hexagon socket head bolt M3 x 8	2 370	4 030	18.7	18.7	15.7	MLG 9
MLC 12	☆	22	65	13	3	7.5	27	20	3.5	25	-	13	-	M3 x 3.5	2.7	12	8	3.5	6.5	4.5	12.5	25	Hexagon socket head bolt M3 x 8	2 210	2 380	14.8	5.3	4.5	MLC 12
ML 12	☆	34		13	3	7.5	27	20	3.5	34	15	21.6	-	M3 x 3.5	2.7	12	8	3.5	6.5	4.5	12.5	25	Hexagon socket head bolt M3 x 8	3 330	4 290	26.6	15.4	12.9	ML 12
MLG 12	☆	48		13	3	7.5	27	20	3.5	44	20	32	-	M3 x 3.5	2.7	12	8	3.5	6.5	4.5	12.5	25	Hexagon socket head bolt M3 x 8	4 310	6 200	38.4	30.6	25.7	MLG 12
MLC 15	☆	43	107	16	4	8.5	32	25	3.5	32	-	17.8	36	M3 x 4	3.1	15	10	3.5	6.5	4.5	20	40	Hexagon socket head bolt M3 x 10	3 490	3 890	30.0	11.7	9.8	MLC 15
ML 15	☆	63		16	4	8.5	32	25	3.5	42	20	27.9	47	M3 x 4	3.1	15	10	3.5	6.5	4.5	20	40	Hexagon socket head bolt M3 x 10	4 980	6 490	50.0	29.7	24.9	ML 15
MLG 15	☆	93		16	4	8.5	32	25	3.5	57	25	42.8	62	M3 x 4	3.1	15	10	3.5	6.5	4.5	20	40	Hexagon socket head bolt M3 x 10	6 620	9 740	75.0	63.9	53.6	MLG 15
MLC 20	☆	89	156	20	5	10	40	30	5	38	-	22.3	42	M4 x 6	4.2	20	11	6	9.5	5.5	30	60	Hexagon socket head bolt M5 x 14	4 580	5 300	54.0	19.4	16.3	MLC 20
ML 20	☆	130		20	5	10	40	30	5	50	25	34.6	55	M4 x 6	4.2	20	11	6	9.5	5.5	30	60	Hexagon socket head bolt M5 x 14	6 650	9 080	92.6	52.7	44.2	ML 20
MLG 20	☆	189		20	5	10	40	30	5	68	30	52.3	72	M4 x 6	4.2	20	11	6	9.5	5.5	30	60	Hexagon socket head bolt M5 x 14	8 510	12 900	131	102	85.7	MLG 20
MLC 25	☆	189	243	25	5	12.5	48	35	6.5	55	-	31.9	65	M6 x 7	5	23	15	7	11.0	9.0	30	60	Hexagon socket head bolt M6 x 16	9 120	10 600	128	57.4	48.1	MLC 25
ML 25	☆	305		25	5	12.5	48	35	6.5	78	35	55.7	89	M6 x 7	5	23	15	7	11.0	9.0	30	60	Hexagon socket head bolt M6 x 16	13 500	18 500	223	163	137	ML 25
MLG 25	☆	405		25	5	12.5	48	35	6.5	98	40	75.5	108	M6 x 7	5	23	15	7	11.0	9.0	30	60	Hexagon socket head bolt M6 x 16	16 700	25 200	303	293	246	MLG 25

Note (1): Track rail lengths L are shown in Table 29.1.

(2): The directions of basic dynamic load rating (C), basic static load rating (C<sub>0</sub>) and static moment rating (T<sub>0</sub>, T<sub>x</sub> and T<sub>y</sub>) are shown in the sketches below.

The upper values in the T<sub>x</sub> and T<sub>y</sub> column apply to one slide unit, and the lower values apply to two units in close contact.

Remark 1: The appended bolts for mounting track rails are hexagon socket head bolts of JIS B 1176 or equivalent, or cross-recessed head cap screws for precision equipment.

2: Oil hole is provided for ML(C)5 to ML(C, G)12 models.

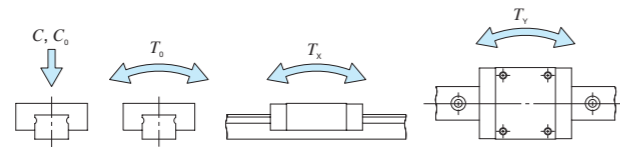

### Example of identification number for assembled set

Model code	Size	Part code	Preload symbol	Class symbol	Interchangeable code	Supplemental code
ML G	9	C2 R160	T <sub>1</sub>	P	S2	/U
<b>Series</b>	ML Standard type				<b>Interchangeable code</b>	<b>Special specification</b>
<b>Length of slide unit</b>	C Short No symbol Standard G High rigidity long				S2 Interchangeable specification No symbol Non interchangeable specification	A, D, E, HB, I, LR, MN, N, S, U, W
<b>Size</b>	5, 7, 9, 12, 15, 20, 25				<b>Preload amount</b>	<b>Accuracy class</b>
<b>Number of slide unit (two slide units)</b>					T <sub>0</sub> Clearance No symbol Standard T <sub>1</sub> Light preload	H High P Precision
<b>Length of track rail (160mm)</b>						

In case ordering track rail only, model code is changed as shown below.

Track rail of interchangeable ML → Model code LWL-B (Ex: LWL9R160BPS2)

1N=0.102kgf=0.2248lbs.  
1mm=0.03937inch

# IKO G-Sleeve Linear Way MLF Wide type

MLFC · MLF · MLFG

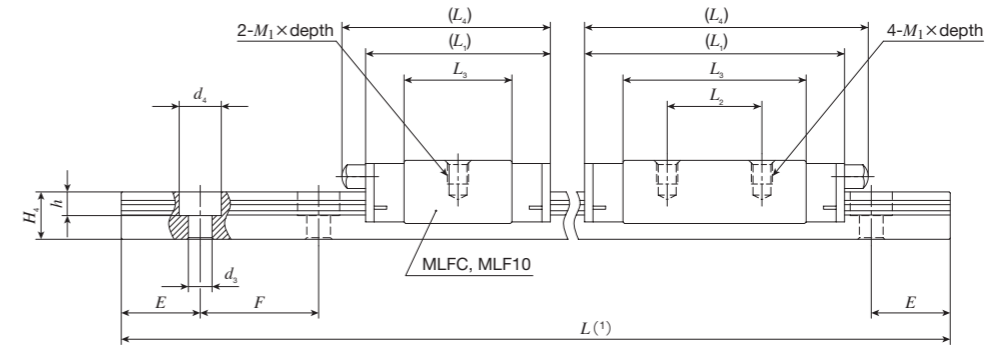
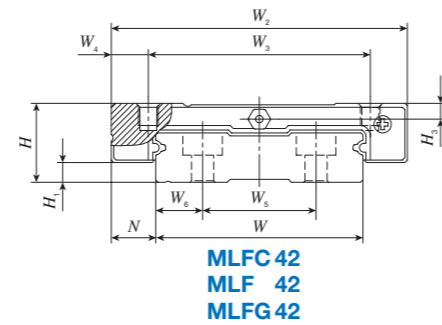
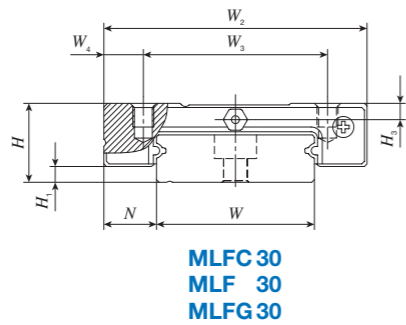
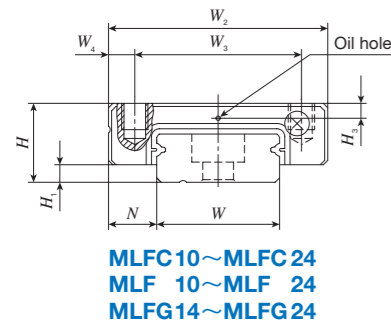

Model number	Interchangeable	Mass (Reference) g		Dimension of assembly mm			Dimension of slide unit mm										Dimension of track rail mm						Appended mounting bolt for track rail mm Bolt size x length	Basic (2) dynamic load rating C	Basic (2) static load rating C <sub>0</sub>	Static moment rating (2)			Model number		
		Slide unit	Track rail (per 100mm)	H	H <sub>1</sub>	N	W <sub>2</sub>	W <sub>3</sub>	W <sub>4</sub>	L <sub>1</sub>	L <sub>2</sub>	L <sub>3</sub>	L <sub>4</sub>	M <sub>1</sub> x depth	H <sub>3</sub>	W	H <sub>4</sub>	W <sub>5</sub>	W <sub>6</sub>	d <sub>3</sub>	d <sub>4</sub>	h				E	F	T <sub>0</sub>		T <sub>x</sub>	T <sub>y</sub>
MLFC 10	☆	6.1	28	6.5	1.5	3.5	17	13	2	20.5	-	13.6	-	M2.5 x 1.5	1.3	10	4	-	-	2.9	4.8	1.6	10	20	Cross-recessed head screw for precision equipment M2.5 x 7	712	1 180	6.1	2.6	2.2	MLFC 10
MLF 10	☆	7.6								24.5		17.6														3.5					
MLFC 14	☆	13	54	9	2	5.5	25	19	3	22.5	-	13	-	M3 x 3	1.7	14	5.5	-	-	3.5	6	3.2	15	30	Hexagon socket head bolt M3 x 8	1 240	1 700	12.2	3.8	3.2	MLFC 14
MLF 14	☆	20								31.5		10														22	5.5				
MLFG 14	☆	29	90	12	3	6	30	21	4.5	42	19	32.5	-	M3 x 3	2.5	18	7	-	-	3.5	6.5	4.5	15	30	Hexagon socket head bolt M3 x 8	2 320	4 160	29.8	21.0	17.6	MLFG 14
MLFC 18	☆	26								26.5		16.6														6					
MLF 18	☆	42	139	14	3	8	40	28	6	39	12	28.6	-	M3 x 3	2.5	18	7	-	-	3.5	6.5	4.5	15	30	Hexagon socket head bolt M3 x 8	2 280	3 810	34.9	16.9	14.2	MLF 18
MLFG 18	☆	59								50.5		24														40.4	6				
MLFC 24	☆	46	198	15	3	10	50	35	7.5	30.5	-	17.7	-	M3 x 3.5	3.2	24	8	-	-	4.5	8	4.5	20	40	Hexagon socket head bolt M4 x 10	2 800	3 340	40.7	9.7	8.2	MLFC 24
MLF 24	☆	74								44		15														31	10				
MLFG 24	☆	108	294	16	4	9	60	45	7.5	59	28	46.3	-	M4 x 4.5	3.1	30	9	-	-	4.5	8	4.5	20	40	Hexagon socket head bolt M4 x 12	5 620	9 060	111	63.3	53.1	MLFG 24
MLFC 30	☆	70								35.5		20.5														40	9				
MLF 30	☆	111	321	107	15.4	13.0	89.9	217	40.8	50	18	34.8	54	M4 x 4.5	3.1	30	9	-	-	4.5	8	4.5	20	40	Hexagon socket head bolt M4 x 12	5 970	8 440	128	48.7	21.7	MLF 30
MLFG 30	☆	167								68.5		35														53.8	73				
MLFC 42	☆	95	674	140	117	565	84.3	426	25.8	41.5	-	25.7	46	M4 x 4.5	3.2	42	10	23	9.5	4.5	8	4.5	20	40	Hexagon socket head bolt M4 x 12	5 440	6 810	144	30.8	15.1	MLFC 42
MLF 42	☆	138								55		20														39.4	60				
MLFG 42	☆	200	117	565	117	565	84.3	426	25.8	74.5	35	58.7	79	M4 x 4.5	3.2	42	10	23	9.5	4.5	8	4.5	20	40	Hexagon socket head bolt M4 x 12	7 050	9 840	209	61.3	51.4	MLF 42
										9 520		15 100														321	140	674			

Note (1): Track rail lengths L are shown in Table 29.2.

(2): The directions of basic dynamic load rating (C), basic static load rating (C<sub>0</sub>) and static moment rating (T<sub>0</sub>, T<sub>x</sub> and T<sub>y</sub>) are shown in the sketches below.

The upper values in the T<sub>x</sub> and T<sub>y</sub> column apply to one slide unit, and the lower values apply to two units in close contact.

Remark 1: The appended bolts for mounting track rails are hexagon socket head bolts of JIS B 1176 or equivalent, or cross-recessed head cap screws for precision equipment.

2: Oil hole is provided for MLF(C, G)10 to MLF(C, G)24 models.

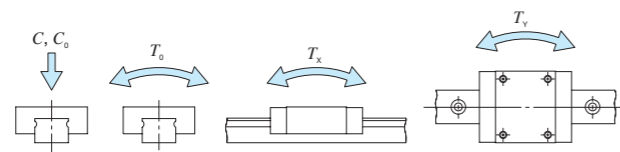

### Example of identification number for assembled set

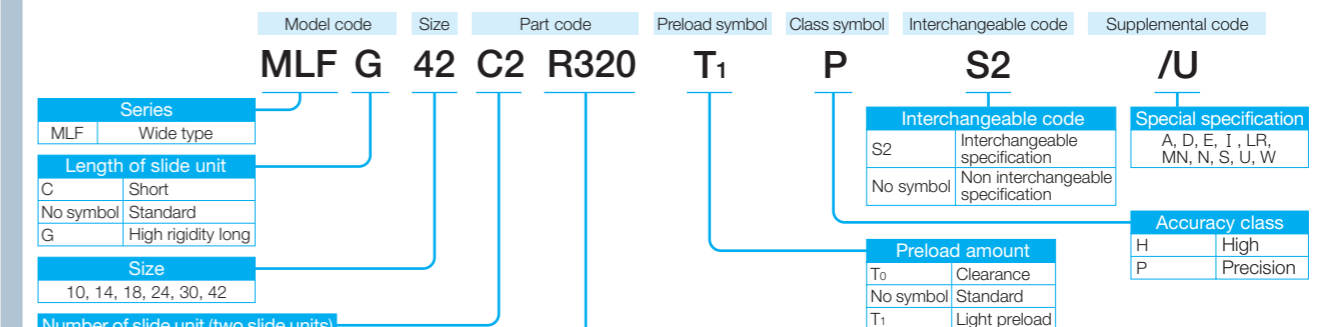

In case ordering track rail only, model code is changed as shown below.

Track rail of interchangeable MLF → Model code LWLF-B (Ex: LWLF42R320BPS2)

1N=0.102kgf=0.2248lbs.  
1mm=0.03937inch



# IKO G-Sleeve Linear Way ME

Flange type,  
mounting from bottom

Short : MEC  
Standard : ME  
High rigidity long : MEG

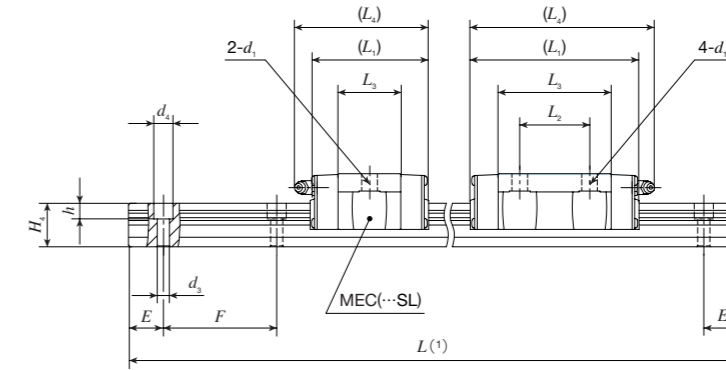
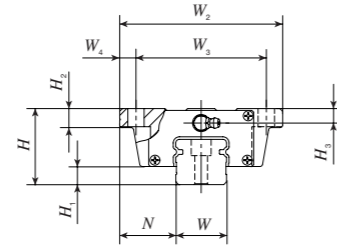

Model number	Interchangeable	Mass (Reference)		Dimension of assembly mm			Dimension of slide unit mm							Dimension of track rail mm							Recommended mounting bolt for track rail mm Bolt size × length	Basic <sup>(3)</sup> dynamic load rating C N	Basic <sup>(3)</sup> static load rating C <sub>0</sub> N	Static moment rating <sup>(3)</sup>			Model number			
		Slide unit kg	Track rail kg/m	H	H <sub>1</sub>	N	W <sub>2</sub>	W <sub>3</sub>	W <sub>4</sub>	L <sub>1</sub>	L <sub>2</sub>	L <sub>3</sub>	L <sub>4</sub>	d <sub>1</sub>	H <sub>2</sub>	H <sub>3</sub>	W	H <sub>4</sub>	d <sub>3</sub>	d <sub>4</sub>				h	E	F		T <sub>0</sub> N·m	T <sub>x</sub> N·m	T <sub>y</sub> N·m
MEC 15	☆	0.11	1.57	24	5.8	18.5	52	41	5.5	41	-	22.4	45	4.5	7	4.5	15	14.5	3.6 (4.5)	6.5 (8)	4.5 (6)	20	60	M3 × 16 (M4 × 16)	5 240	5 480	43.8	21.3 149	21.3 149	MEC 15
MEC 15...SL	☆									57	26	38.4	61												MEC 15...SL					
ME 15	☆	0.18	1.57	24	5.8	18.5	52	41	5.5	57	26	38.4	61	4.5	7	4.5	15	14.5	3.6 (4.5)	6.5 (8)	4.5 (6)	20	60	M3 × 16 (M4 × 16)	7 640	9 390	75.1	57.6 333	57.6 333	ME 15
ME 15...SL	☆									70	36	51.1	74												ME 15...SL					
MEG 15	☆	0.24	1.57	24	5.8	18.5	52	41	5.5	70	36	51.1	74	4.5	7	4.5	15	14.5	3.6 (4.5)	6.5 (8)	4.5 (6)	20	60	M3 × 16 (M4 × 16)	9 340	12 500	100	99.5 533	99.5 533	MEG 15
MEG 15...SL	☆									MEG 15...SL																				
MEC 20	☆	0.18	2.28	28	6	19.5	59	49	5	47	-	24.7	59	5.5	9	5.5	20	16	6	9.5	8.5	20	60	M5 × 16	7 580	7 340	78.9	31.5 235	31.5 235	MEC 20
MEC 20...SL	☆									66.5	32	44.2	79												MEC 20...SL					
ME 20	☆	0.30	2.28	28	6	19.5	59	49	5	66.5	32	44.2	79	5.5	9	5.5	20	16	6	9.5	8.5	20	60	M5 × 16	11 600	13 400	145	95.6 561	95.6 561	ME 20
ME 20...SL	☆									82	45	60.1	95												ME 20...SL					
MEG 20	☆	0.39	2.28	28	6	19.5	59	49	5	82	45	60.1	95	5.5	9	5.5	20	16	6	9.5	8.5	20	60	M5 × 16	14 400	18 300	197	172 918	172 918	MEG 20
MEG 20...SL	☆									MEG 20...SL																				
MEC 25	☆	0.33	3.09	33	7	25	73	60	6.5	59	-	32	71	7	10	6.5	23	19	7	11	9	20	60	M6 × 20	12 400	12 300	153	71.8 480	71.8 480	MEC 25
MEC 25...SL	☆									83	35	56	95												MEC 25...SL					
ME 25	☆	0.54	3.09	33	7	25	73	60	6.5	83	35	56	95	7	10	6.5	23	19	7	11	9	20	60	M6 × 20	18 100	21 100	262	195 1 090	195 1 090	ME 25
ME 25...SL	☆									102	50	75	114												ME 25...SL					
MEG 25	☆	0.72	3.09	33	7	25	73	60	6.5	102	50	75	114	7	10	6.5	23	19	7	11	9	20	60	M6 × 20	22 200	28 200	349	336 1 740	336 1 740	MEG 25
MEG 25...SL	☆									MEG 25...SL																				

Note (1) : Track rail lengths L are shown in Table 29.3.

(2) : Track rail mounting bolts are not appended. Hexagon socket bolts of JIS B 1176 strength division 12.9 or equivalent are recommended. Values in parentheses are applicable to the track rail of supplemental code "/M4" of special specification.

(3) : The directions of basic dynamic load rating (C), basic static load rating (C<sub>0</sub>) and static moment rating (T<sub>0</sub>, T<sub>x</sub> and T<sub>y</sub>) are shown in the sketches below.  
The upper values in the T<sub>x</sub> and T<sub>y</sub> column apply to one slide unit, and the lower values apply to two units in close contact.

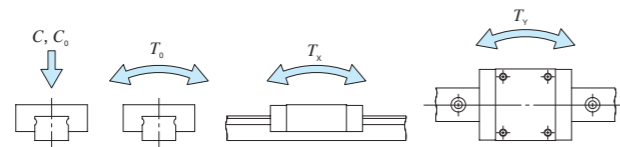

### Example of identification number for assembled set

Model code	Size	Part code	Material code	Preload symbol	Class symbol	Interchangeable code	Supplemental code
<b>ME G 20 C2 R820</b>				<b>T<sub>1</sub></b>	<b>P</b>	<b>S2</b>	<b>/U</b>
<b>Series</b>	ME Flange type, mounting from bottom					<b>Interchangeable code</b>	<b>Special specification</b>
<b>Length of slide unit</b>	C Short No symbol Standard G High rigidity long					S2 Interchangeable specification No symbol Non interchangeable specification	A, D, E, F, I, J, L, LF, MA, M4, N, T, U, V, W, Z
<b>Size</b>	15, 20, 25						
<b>Number of slide unit (two slide units)</b>							
<b>Length of track rail (820mm)</b>							
<b>Material</b>	No symbol High carbon steel SL Stainless steel						
						<b>Preload amount</b>	<b>Accuracy class</b>
						T <sub>0</sub> Clearance No symbol Standard T <sub>1</sub> Light preload T <sub>2</sub> Medium preload	No symbol Ordinary H High P Precision SP Super precision

In case ordering track rail only, model code is changed as shown below.  
Track rail of interchangeable ME → Model code LWE (Ex: LWE20R820PS2)

1N=0.102kgf=0.2248lbs.  
1mm=0.03937inch

# IKO G-Sleeve Linear Way ME

Flange type,  
mounting from bottom

Short : MEC  
Standard : ME  
High rigidity long : MEG

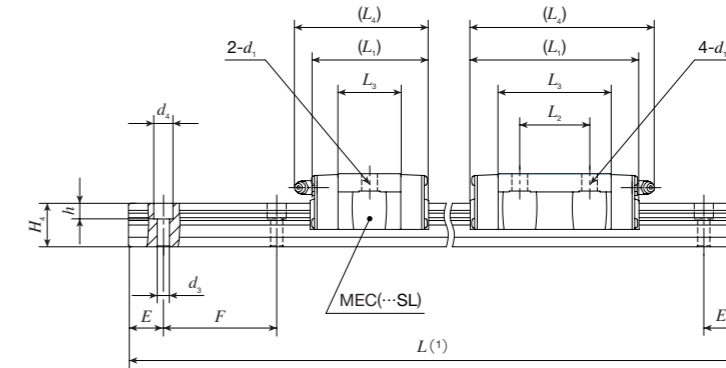
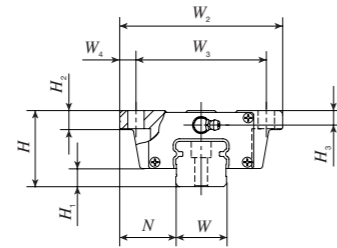

Model number	Interchangeable	Mass (Reference)		Dimension of assembly mm			Dimension of slide unit mm									Dimension of track rail mm							Recommended mounting bolt for track rail mm Bolt size × length	Basic <sup>(3)</sup> dynamic load rating C N	Basic <sup>(3)</sup> static load rating C <sub>0</sub> N	Static moment rating <sup>(3)</sup>			Model number	
		Slide unit kg	Track rail kg/m	H	H <sub>1</sub>	N	W <sub>2</sub>	W <sub>3</sub>	W <sub>4</sub>	L <sub>1</sub>	L <sub>2</sub>	L <sub>3</sub>	L <sub>4</sub>	d <sub>1</sub>	H <sub>2</sub>	H <sub>3</sub>	W	H <sub>4</sub>	d <sub>3</sub>	d <sub>4</sub>	h	E				F	T <sub>0</sub> N·m	T <sub>x</sub> N·m		T <sub>y</sub> N·m
MEC 30	☆	0.58	5.09	42	10	31	90	72	9	68	-	36	78	9	10	8	28	25	7	11	9	20	80	M 6 × 25	20 600	18 800	287	129 855	129 855	MEC 30
MEC 30...SL	☆									MEC 30...SL																				
ME 30	☆									ME 30																				
ME 30...SL	☆									ME 30...SL																				
MEG 30	☆									MEG 30																				
MEG 30...SL	☆	1.50	128.5	60	96.5	139	MEG 30...SL																							
MEC 35	☆	0.84	6.85	48	11	33	100	82	9	78	-	41.6	90	9	13	10	34	28	9	14	12	20	80	M 8 × 30	29 900	26 800	412	176 190	162 100	MEC 35
ME 35	☆									1.52	111	50	74.6																	123
ME 45	☆	2.46	11.2	60	14	37.5	120	100	10	125	60	81.4	136	11	15	13	45	34	11	17.5	14	22.5	105	M10 × 35	61 100	60 200	1 210	672 4 070	618 3 750	ME 45

Note (1) : Track rail lengths L are shown in Table 29.3.

(2) : Track rail mounting bolts are not appended. Hexagon socket bolts of JIS B 1176 strength division 12.9 or equivalent are recommended.

(3) : The directions of basic dynamic load rating (C), basic static load rating (C<sub>0</sub>) and static moment rating (T<sub>0</sub>, T<sub>x</sub> and T<sub>y</sub>) are shown in the sketches below.  
The upper values in the T<sub>x</sub> and T<sub>y</sub> column apply to one slide unit, and the lower values apply to two units in close contact.

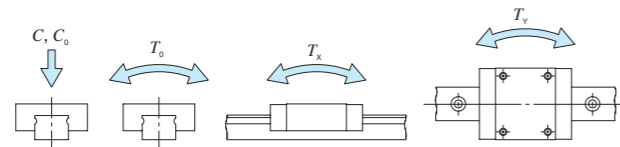

### Example of identification number for assembled set

Model code	Size	Part code	Material code	Preload symbol	Class symbol	Interchangeable code	Supplemental code
<b>ME G 30 C2 R440</b>				<b>T<sub>1</sub></b>	<b>P</b>	<b>S2</b>	<b>/U</b>
<b>Series</b> ME Flange type, mounting from bottom	<b>Length of slide unit</b> C Short No symbol Standard G High rigidity long	<b>Size</b> 30, 35, 45	<b>Number of slide unit (two slide units)</b>	<b>Length of track rail (440mm)</b>	<b>Material</b> No symbol High carbon steel SL Stainless steel	<b>Interchangeable code</b> S2 Interchangeable specification No symbol Non interchangeable specification	<b>Special specification</b> A, D, E, F, I, J, L, LF, MA, N, T, U, V, W, Z
				<b>Preload amount</b> T <sub>0</sub> Clearance No symbol Standard T <sub>1</sub> Light preload T <sub>2</sub> Medium preload	<b>Accuracy class</b> No symbol Ordinary H High P Precision SP Super precision		

In case ordering track rail only, model code is changed as shown below.  
Track rail of interchangeable ME → Model code LWE (Ex: LWE30R440PS2)

1N=0.102kgf=0.2248lbs.  
1mm=0.03937inch

# IKO C-Sleeve Linear Way ME

Flange type,  
mounting from top

Short : METC  
Standard : MET  
High rigidity long : METG

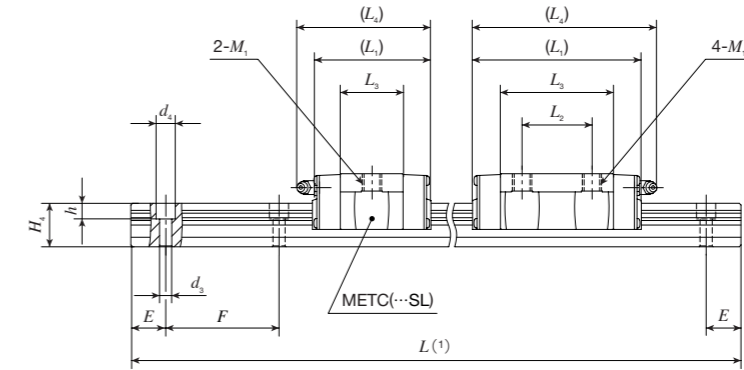
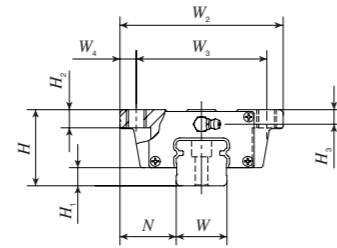

Model number	Interchangeable	Mass (Reference)		Dimension of assembly mm			Dimension of slide unit mm							Dimension of track rail mm							Recommended mounting bolt for track rail mm Bolt size × length	Basic <sup>(3)</sup> dynamic load rating C	Basic <sup>(3)</sup> static load rating C <sub>0</sub>	Static moment rating <sup>(3)</sup>			Model number			
		Slide unit kg	Track rail kg/m	H	H <sub>1</sub>	N	W <sub>2</sub>	W <sub>3</sub>	W <sub>4</sub>	L <sub>1</sub>	L <sub>2</sub>	L <sub>3</sub>	L <sub>4</sub>	M <sub>1</sub>	H <sub>2</sub>	H <sub>3</sub>	W	H <sub>4</sub>	d <sub>3</sub>	d <sub>4</sub>				h	E	F		T <sub>0</sub>	T <sub>x</sub>	T <sub>y</sub>
METC 15	☆	0.11	1.57	24	5.8	18.5	52	41	5.5	41	-	22.4	45	M5	7	4.5	15	14.5	3.6 (4.5)	6.5 (8)	4.5 (6)	20	60	M3 × 16 (M4 × 16)	5 240	5 480	43.8	21.3 149	21.3 149	METC 15
METC 15...SL	☆									METC 15...SL																				
MET 15	☆	0.18	1.57	24	5.8	18.5	52	41	5.5	57	26	38.4	61	M5	7	4.5	15	14.5	3.6 (4.5)	6.5 (8)	4.5 (6)	20	60	M3 × 16 (M4 × 16)	7 640	9 390	75.1	57.6 333	57.6 333	MET 15
MET 15...SL	☆									MET 15...SL																				
METG 15	☆	0.24	1.57	24	5.8	18.5	52	41	5.5	70	36	51.1	74	M5	7	4.5	15	14.5	3.6 (4.5)	6.5 (8)	4.5 (6)	20	60	M3 × 16 (M4 × 16)	9 340	12 500	100	99.5 533	99.5 533	METG 15
METG 15...SL	☆									METG 15...SL																				
METC 20	☆	0.18	2.28	28	6	19.5	59	49	5	47	-	24.7	59	M6	9	5.5	20	16	6	9.5	8.5	20	60	M5 × 16	7 580	7 340	78.9	31.5 235	31.5 235	METC 20
METC 20...SL	☆									METC 20...SL																				
MET 20	☆	0.30	2.28	28	6	19.5	59	49	5	66.5	32	44.2	79	M6	9	5.5	20	16	6	9.5	8.5	20	60	M5 × 16	11 600	13 400	145	95.6 561	95.6 561	MET 20
MET 20...SL	☆									MET 20...SL																				
METG 20	☆	0.39	2.28	28	6	19.5	59	49	5	82	45	60.1	95	M6	9	5.5	20	16	6	9.5	8.5	20	60	M5 × 16	14 400	18 300	197	172 918	172 918	METG 20
METG 20...SL	☆									METG 20...SL																				
METC 25	☆	0.33	3.09	33	7	25	73	60	6.5	59	-	32	71	M8	10	6.5	23	19	7	11	9	20	60	M6 × 20	12 400	12 300	153	71.8 480	71.8 480	METC 25
METC 25...SL	☆									METC 25...SL																				
MET 25	☆	0.54	3.09	33	7	25	73	60	6.5	83	35	56	95	M8	10	6.5	23	19	7	11	9	20	60	M6 × 20	18 100	21 100	262	195 1 090	195 1 090	MET 25
MET 25...SL	☆									MET 25...SL																				
METG 25	☆	0.72	3.09	33	7	25	73	60	6.5	102	50	75	114	M8	10	6.5	23	19	7	11	9	20	60	M6 × 20	22 200	28 200	349	336 1 740	336 1 740	METG 25
METG 25...SL	☆									METG 25...SL																				

Note (1) : Track rail lengths L are shown in Table 29.3.

(2) : Track rail mounting bolts are not appended. Hexagon socket bolts of JIS B 1176 strength division 12.9 or equivalent are recommended. Values in parentheses are applicable to the track rail of supplemental code "/M4" of special specification.

(3) : The directions of basic dynamic load rating (C), basic static load rating (C<sub>0</sub>) and static moment rating (T<sub>0</sub>, T<sub>x</sub> and T<sub>y</sub>) are shown in the sketches below.  
The upper values in the T<sub>x</sub> and T<sub>y</sub> column apply to one slide unit, and the lower values apply to two units in close contact.

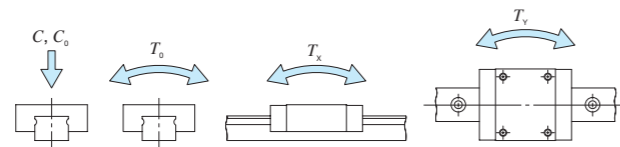

### Example of identification number for assembled set

Model code	Size	Part code	Material code	Preload symbol	Class symbol	Interchangeable code	Supplemental code
<b>MET G 20 C2 R820</b>				<b>T<sub>1</sub></b>	<b>P</b>	<b>S2</b>	<b>/U</b>
<b>Series</b>	<b>Length of slide unit</b>	<b>Size</b>	<b>Number of slide unit (two slide units)</b>	<b>Length of track rail (820mm)</b>	<b>Material</b>	<b>Interchangeable code</b>	<b>Special specification</b>
MET Flange type, mounting from top	C Short No symbol Standard G High rigidity long	15, 20, 25	No symbol SL	No symbol High carbon steel SL Stainless steel	No symbol High carbon steel SL Stainless steel	S2 Interchangeable specification No symbol Non interchangeable specification	A, D, E, F, I, J, L, LF, MA, M4, N, T, U, V, W, Z
						<b>Preload amount</b>	<b>Accuracy class</b>
						T <sub>0</sub> Clearance No symbol Standard T <sub>1</sub> Light preload T <sub>2</sub> Medium preload	No symbol Ordinary H High P Precision SP Super precision

In case ordering track rail only, model code is changed as shown below.  
Track rail of interchangeable ME → Model code LWE (Ex: LWE20R820PS2)

1N=0.102kgf=0.2248lbs.  
1mm=0.03937inch



# IKO G-Sleeve Linear Way ME

Flange type,  
mounting from top

Short : METC  
Standard : MET  
High rigidity long : METG

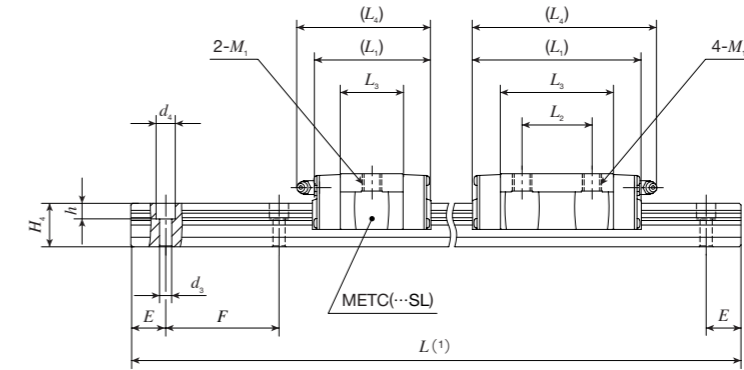
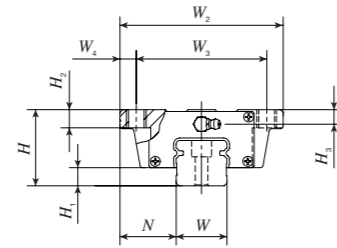

Model number	Interchangeable	Mass (Reference)		Dimension of assembly mm			Dimension of slide unit mm									Dimension of track rail mm							Recommended mounting bolt for track rail mm Bolt size × length	Basic <sup>(3)</sup> dynamic load rating C N	Basic <sup>(3)</sup> static load rating C <sub>0</sub> N	Static moment rating <sup>(3)</sup>			Model number	
		Slide unit kg	Track rail kg/m	H	H <sub>1</sub>	N	W <sub>2</sub>	W <sub>3</sub>	W <sub>4</sub>	L <sub>1</sub>	L <sub>2</sub>	L <sub>3</sub>	L <sub>4</sub>	M <sub>1</sub>	H <sub>2</sub>	H <sub>3</sub>	W	H <sub>4</sub>	d <sub>3</sub>	d <sub>4</sub>	h	E				F	T <sub>0</sub> N·m	T <sub>x</sub> N·m		T <sub>y</sub> N·m
METC 30	☆	0.58	5.09	42	10	31	90	72	9	68	-	36	78	M10	10	8	28	25	7	11	9	20	80	M 6 × 25	20 600	18 800	287	129 855	129 855	METC 30
METC 30...SL	☆									METC 30...SL																				
MET 30	☆	0.99	5.09	42	10	31	90	72	9	97	40	64.8	107	M10	10	8	28	25	7	11	9	20	80	M 6 × 25	29 500	31 300	479	328 1 920	328 1 920	MET 30
MET 30...SL	☆									MET 30...SL																				
METG 30	☆	1.50	5.09	42	10	31	90	72	9	128.5	60	96.5	139	M10	10	8	28	25	7	11	9	20	80	M 6 × 25	39 200	47 000	718	704 3 670	704 3 670	METG 30
METG 30...SL	☆									METG 30...SL																				
METC 35	☆	0.84	6.85	48	11	33	100	82	9	78	-	41.6	90	M10	13	10	34	28	9	14	12	20	80	M 8 × 30	29 900	26 800	412	176 1 190	162 1 100	METC 35
MET 35	☆									1.52	111	50	74.6																	123
MET 45	☆	2.46	11.2	60	14	37.5	120	100	10	125	60	81.4	136	M12	15	13	45	34	11	17.5	14	22.5	105	M10 × 35	61 100	60 200	1 210	672 4 070	618 3 750	MET 45

Note (1) : Track rail lengths L are shown in Table 29.3.

(2) : Track rail mounting bolts are not appended. Hexagon socket bolts of JIS B 1176 strength division 12.9 or equivalent are recommended.

(3) : The directions of basic dynamic load rating (C), basic static load rating (C<sub>0</sub>) and static moment rating (T<sub>0</sub>, T<sub>x</sub> and T<sub>y</sub>) are shown in the sketches below.  
The upper values in the T<sub>x</sub> and T<sub>y</sub> column apply to one slide unit, and the lower values apply to two units in close contact.

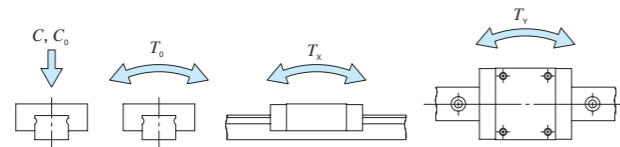

### Example of identification number for assembled set

Model code	Size	Part code	Material code	Preload symbol	Class symbol	Interchangeable code	Supplemental code	
<b>MET G</b>	<b>30</b>	<b>C2 R440</b>		<b>T<sub>1</sub></b>	<b>P</b>	<b>S2</b>	<b>/U</b>	
<b>Series</b> MET Flange type, mounting from top	<b>Length of slide unit</b> C Short No symbol Standard G High rigidity long	<b>Size</b> 30, 35, 45	<b>Number of slide unit (two slide units)</b>	<b>Length of track rail (440mm)</b>	<b>Material</b> No symbol High carbon steel SL Stainless steel	<b>Preload amount</b> T <sub>0</sub> Clearance No symbol Standard T <sub>1</sub> Light preload T <sub>2</sub> Medium preload	<b>Interchangeable code</b> S2 Interchangeable specification No symbol Non interchangeable specification	<b>Special specification</b> A, D, E, F, I, J, L, LF, MA, N, T, U, V, W, Z
						<b>Accuracy class</b> No symbol Ordinary H High P Precision SP Super precision		

In case ordering track rail only, model code is changed as shown below.  
Track rail of interchangeable ME → Model code LWE (Ex: LWE30R440PS2)

1N=0.102kgf=0.2248lbs.  
1mm=0.03937inch

# IKO C-Sleeve Linear Way ME

Block type,  
mounting from top

Short : MESG  
Standard : MES  
High rigidity long : MESG

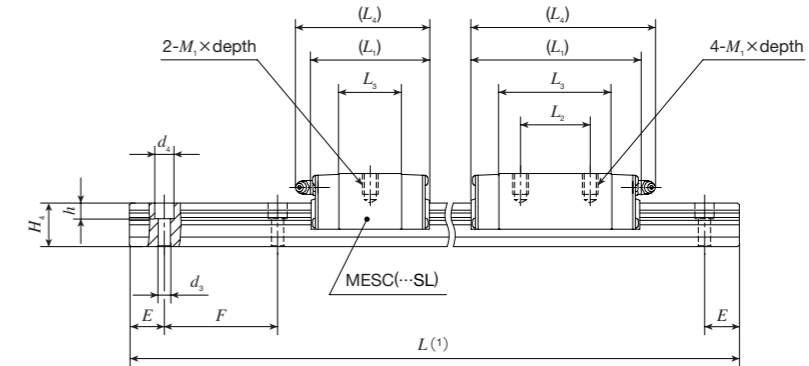
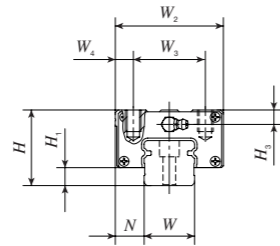

Model number	Interchangeable	Mass (Reference)		Dimension of assembly mm			Dimension of slide unit mm							Dimension of track rail mm							Recommended mounting bolt for track rail mm Bolt size × length	Basic <sup>(3)</sup> dynamic load rating C	Basic <sup>(3)</sup> static load rating C <sub>0</sub>	Static moment rating <sup>(3)</sup>			Model number		
		Slide unit kg	Track rail kg/m	H	H <sub>1</sub>	N	W <sub>2</sub>	W <sub>3</sub>	W <sub>4</sub>	L <sub>1</sub>	L <sub>2</sub>	L <sub>3</sub>	L <sub>4</sub>	M <sub>1</sub> × depth	H <sub>3</sub>	W	H <sub>4</sub>	d <sub>3</sub>	d <sub>4</sub>	h				E	F	T <sub>0</sub>		T <sub>x</sub>	T <sub>y</sub>
MESC 15	☆	0.09	1.57	24	5.8	9.5	34	26	4	41	-	22.4	45	M4 × 7	4.5	15	14.5	3.6 (4.5)	6.5 (8)	4.5 (6)	20	60	M3 × 16 (M4 × 16)	5 240	5 480	43.8	21.3 149	21.3 149	MESC 15
MESC 15...SL	☆									MESC 15...SL																			
MES 15	☆	0.14	1.57	24	5.8	9.5	34	26	4	57	26	38.4	61	M4 × 7	4.5	15	14.5	3.6 (4.5)	6.5 (8)	4.5 (6)	20	60	M3 × 16 (M4 × 16)	7 640	9 390	75.1	57.6 333	57.6 333	MES 15
MES 15...SL	☆									MES 15...SL																			
MESG 15	☆	0.18	1.57	24	5.8	9.5	34	26	4	70	36	51.1	74	M4 × 7	4.5	15	14.5	3.6 (4.5)	6.5 (8)	4.5 (6)	20	60	M3 × 16 (M4 × 16)	9 340	12 500	100	99.5 533	99.5 533	MESG 15
MESG 15...SL	☆									MESG 15...SL																			
MESC 20	☆	0.15	2.28	28	6	11	42	32	5	47	-	24.7	59	M5 × 8	5.5	20	16	6	9.5	8.5	20	60	M5 × 16	7 580	7 340	78.9	31.5 235	31.5 235	MESC 20
MESC 20...SL	☆									MESC 20...SL																			
MES 20	☆	0.25	2.28	28	6	11	42	32	5	66.5	32	44.2	79	M5 × 8	5.5	20	16	6	9.5	8.5	20	60	M5 × 16	11 600	13 400	145	95.6 561	95.6 561	MES 20
MES 20...SL	☆									MES 20...SL																			
MESG 20	☆	0.32	2.28	28	6	11	42	32	5	82	45	60.1	95	M5 × 8	5.5	20	16	6	9.5	8.5	20	60	M5 × 16	14 400	18 300	197	172 918	172 918	MESG 20
MESG 20...SL	☆									MESG 20...SL																			
MESC 25	☆	0.26	3.09	33	7	12.5	48	35	6.5	59	-	32	71	M6 × 9	6.5	23	19	7	11	9	20	60	M6 × 20	12 400	12 300	153	71.8 480	71.8 480	MESC 25
MESC 25...SL	☆									MESC 25...SL																			
MES 25	☆	0.41	3.09	33	7	12.5	48	35	6.5	83	35	56	95	M6 × 9	6.5	23	19	7	11	9	20	60	M6 × 20	18 100	21 100	262	195 1 090	195 1 090	MES 25
MES 25...SL	☆									MES 25...SL																			
MESG 25	☆	0.54	3.09	33	7	12.5	48	35	6.5	102	50	75	114	M6 × 9	6.5	23	19	7	11	9	20	60	M6 × 20	22 200	28 200	349	336 1 740	336 1 740	MESG 25
MESG 25...SL	☆									MESG 25...SL																			

Note (1) : Track rail lengths L are shown in Table 29.3.

(2) : Track rail mounting bolts are not appended. Hexagon socket bolts of JIS B 1176 strength division 12.9 or equivalent are recommended. Values in parentheses are applicable to the track rail of supplemental code "/M4" of special specification.

(3) : The directions of basic dynamic load rating (C), basic static load rating (C<sub>0</sub>) and static moment rating (T<sub>0</sub>, T<sub>x</sub> and T<sub>y</sub>) are shown in the sketches below.  
The upper values in the T<sub>x</sub> and T<sub>y</sub> column apply to one slide unit, and the lower values apply to two units in close contact.

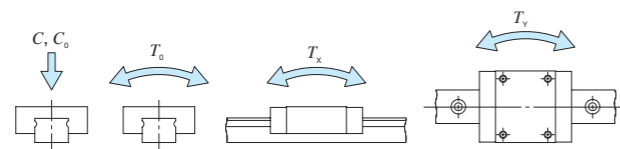

### Example of identification number for assembled set

Model code	Size	Part code	Material code	Preload symbol	Class symbol	Interchangeable code	Supplemental code
MES G	20	C2 R820		T <sub>1</sub>	P	S2	/U
<b>Series</b>	<b>Length of slide unit</b>	<b>Size</b>	<b>Number of slide unit (two slide units)</b>	<b>Length of track rail (820mm)</b>	<b>Material</b>	<b>Interchangeable code</b>	<b>Special specification</b>
MES Block type, mounting from top	C Short No symbol Standard G High rigidity long	15, 20, 25	No symbol High carbon steel SL Stainless steel	No symbol High carbon steel SL Stainless steel	No symbol High carbon steel SL Stainless steel	S2 Interchangeable specification No symbol Non interchangeable specification	A, D, E, F, I, J, L, LF, MA, M4, N, T, U, V, W, Z
						<b>Preload amount</b>	<b>Accuracy class</b>
						T <sub>0</sub> Clearance No symbol Standard T <sub>1</sub> Light preload T <sub>2</sub> Medium preload	No symbol Ordinary H High P Precision SP Super precision

In case ordering track rail only, model code is changed as shown below.  
Track rail of interchangeable ME → Model code LWE (Ex: LWE20R820PS2)

1N=0.102kgf=0.2248lbs.  
1mm=0.03937inch

# IKO C-Sleeve Linear Way ME

Block type,  
mounting from top

Short : MESC  
Standard : MES  
High rigidity long : MESG

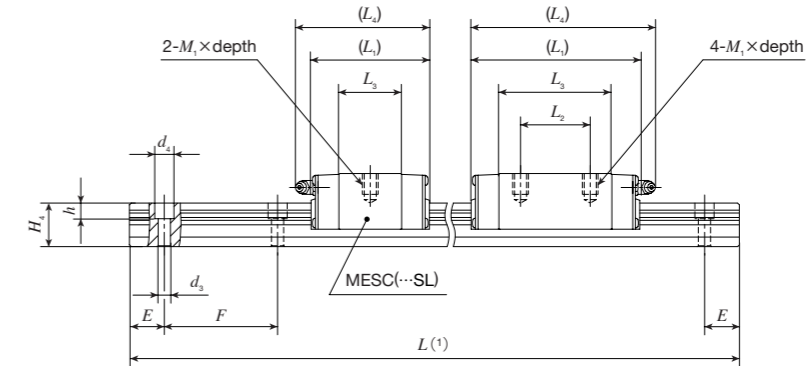
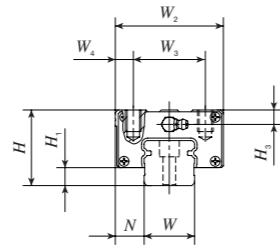

Model number	Interchangeable	Mass (Reference)		Dimension of assembly mm			Dimension of slide unit mm								Dimension of track rail mm							Recommended mounting bolt for track rail mm Bolt size × length	Basic <sup>(3)</sup> dynamic load rating C N	Basic <sup>(3)</sup> static load rating C <sub>0</sub> N	Static moment rating <sup>(3)</sup>			Model number	
		Slide unit kg	Track rail kg/m	H	H <sub>1</sub>	N	W <sub>2</sub>	W <sub>3</sub>	W <sub>4</sub>	L <sub>1</sub>	L <sub>2</sub>	L <sub>3</sub>	L <sub>4</sub>	M <sub>1</sub> × depth	H <sub>3</sub>	W	H <sub>4</sub>	d <sub>3</sub>	d <sub>4</sub>	h	E				F	T <sub>0</sub> N·m	T <sub>x</sub> N·m		T <sub>y</sub> N·m
MESC 30	☆	0.46	5.09	42	10	16	60	40	10	68	-	36	78	M 8 × 12	8	28	25	7	11	9	20	80	M 6 × 25	20 600	18 800	287	129 855	129 855	MESC 30
MESC 30...SL	☆									MESC 30...SL																			
MES 30	☆									MES 30																			
MES 30...SL	☆									MES 30...SL																			
MESG 30	☆									MESG 30																			
MESG 30...SL	☆	1.13	128.5	60	96.5	139	MESG 30...SL																						
MESC 35	☆	0.67	6.85	48	11	18	70	50	10	78	-	41.6	90	M 8 × 12	10	34	28	9	14	12	20	80	M 8 × 30	29 900	26 800	412	176 190	162 100	MESC 35
MES 35	☆									1.21	111	50	74.6																123
MES 45	☆	2.05	11.2	60	14	20.5	86	60	10	125	60	81.4	136	M10 × 15	13	45	34	11	17.5	14	22.5	105	M10 × 35	61 100	60 200	1 210	672 4 070	618 3 750	MES 45

Note (1): Track rail lengths L are shown in Table 29.3.

(2): Track rail mounting bolts are not appended. Hexagon socket bolts of JIS B 1176 strength division 12.9 or equivalent are recommended.

(3): The directions of basic dynamic load rating (C), basic static load rating (C<sub>0</sub>) and static moment rating (T<sub>0</sub>, T<sub>x</sub> and T<sub>y</sub>) are shown in the sketches below. The upper values in the T<sub>x</sub> and T<sub>y</sub> column apply to one slide unit, and the lower values apply to two units in close contact.

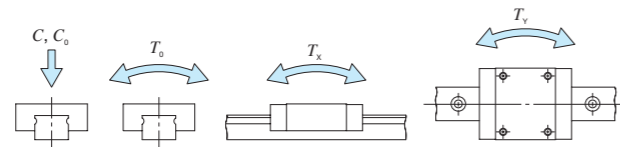

### Example of identification number for assembled set

Model code	Size	Part code	Material code	Preload symbol	Class symbol	Interchangeable code	Supplemental code	
MES G	30	C2 R440		T <sub>1</sub>	P	S2	/U	
<b>Series</b> MES Block type, mounting from top	<b>Length of slide unit</b> C Short No symbol Standard G High rigidity long	<b>Size</b> 30, 35, 45	<b>Number of slide unit (two slide units)</b>	<b>Length of track rail (440mm)</b>	<b>Material</b> No symbol High carbon steel SL Stainless steel	<b>Preload amount</b> T <sub>0</sub> Clearance No symbol Standard T <sub>1</sub> Light preload T <sub>2</sub> Medium preload	<b>Interchangeable code</b> S2 Interchangeable specification No symbol Non interchangeable specification	<b>Special specification</b> A, D, E, F, I, J, L, LF, MA, N, T, U, V, W, Z
						<b>Accuracy class</b> No symbol Ordinary H High P Precision SP Super precision		

In case ordering track rail only, model code is changed as shown below.  
Track rail of interchangeable ME → Model code LWE (Ex: LWE30R440PS2)

1N=0.102kgf=0.2248lbs.  
1mm=0.03937inch



# IKO C-Sleeve Linear Way MH

Flange type,  
mounting from bottom

Standard : MH  
High rigidity long : MHG

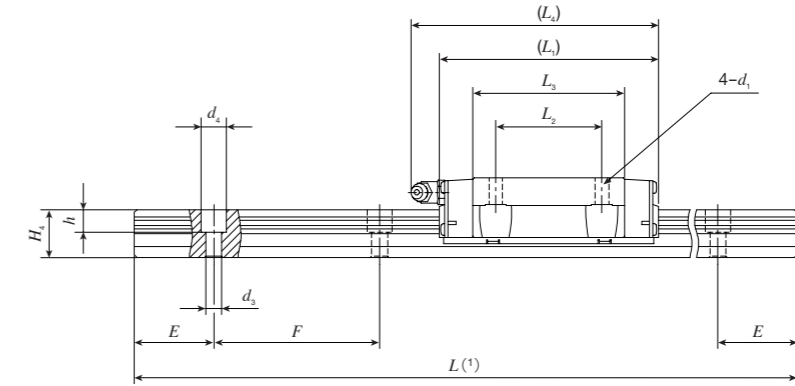
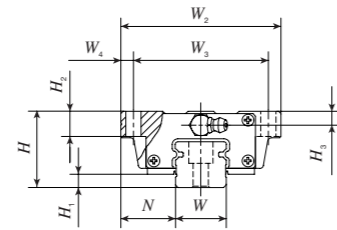

Model number	Interchangeable	Mass (Reference)		Dimension of assembly mm			Dimension of slide unit mm										Dimension of track rail mm							Recommended mounting bolt for track rail mm Bolt size × length	Basic <sup>(3)</sup> dynamic load rating C	Basic <sup>(3)</sup> static load rating C <sub>0</sub>	Static moment rating <sup>(3)</sup>			Model number
		Slide unit kg	Track rail kg/m	H	H <sub>1</sub>	N	W <sub>2</sub>	W <sub>3</sub>	W <sub>4</sub>	L <sub>1</sub>	L <sub>2</sub>	L <sub>3</sub>	L <sub>4</sub>	d <sub>1</sub> <sup>(4)</sup>	H <sub>2</sub>	H <sub>3</sub>	W	H <sub>4</sub>	d <sub>3</sub>	d <sub>4</sub>	h	E	F				T <sub>0</sub>	T <sub>x</sub>	T <sub>y</sub>	
MH 15	☆	0.22	1.47	24	4.5	16	47	38	4.5	66	30	44.2	69	4.5	7	4.5	15	15	4.5	8	6	30	60	M 4 × 16	11 600	13 400	112	95.6 556	95.6 556	MH 15
MH 20	☆	0.47	2.56	30	5	21.5	63	53	5	83	40	56	95	6	10	5.5	20	18	6	9.5	8.5	30	60	M 5 × 18	18 100	21 100	232	195 1 090	195 1 090	MH 20
MHG 20	☆	0.69								112		84.8	124												24 100	31 700	349	421 2 140	421 2 140	MHG 20
MH 25	☆	0.69	3.50	36	6.5	23.5	70	57	6.5	95	45	63.9	106	7	10	6.5	23	22	7	11	9	30	60	M 6 × 22	25 200	28 800	362	309 1 690	309 1 690	MH 25
MHG 25	☆	0.91								118		86.6	129												30 800	38 300	483	533 2 740	533 2 740	MHG 25
MH 30	☆	1.28	4.82	42	7	31	90	72	9	113	52	80.6	124	9	10	8	28	25	9	14	12	40	80	M 8 × 28	35 400	40 700	623	536 2 820	536 2 820	MH 30
MHG 30	☆	1.69								139		106.6	150												42 700	53 200	814	894 4 460	894 4 460	MHG 30
MH 35	☆	1.79	6.85	48	8	33	100	82	9	123	62	86.2	135	9	13	10	34	28	9	14	12	40	80	M 8 × 28	48 700	53 700	823	631 3 480	579 3 190	MH 35
MHG 35	☆	2.35								151		114	163												59 500	71 600	1 100	1 090 5 570	1 000 5 110	MHG 35
MH 45	☆	3.17	10.7	60	10	37.5	120	100	10	147	80	103.4	158	11	15	13	45	34	14	20	17	52.5	100	M12 × 35	74 600	80 200	1 610	1 150 6 190	1 060 5 690	MH 45
MHG 45	☆	4.34								190		146.6	201												95 200	114 000	2 280	2 240 11 100	2 050 10 200	MHG 45

Note (1) : Track rail lengths L are shown in Table 29.4.

(2) : Track rail mounting bolts are not appended. Hexagon socket bolts of JIS B 1176 strength division 12.9 or equivalent are recommended.

(3) : The directions of basic dynamic load rating (C), basic static load rating (C<sub>0</sub>) and static moment rating (T<sub>0</sub>, T<sub>x</sub> and T<sub>y</sub>) are shown in the sketches below.  
The upper values in the T<sub>x</sub> and T<sub>y</sub> column apply to one slide unit, and the lower values apply to two units in close contact.

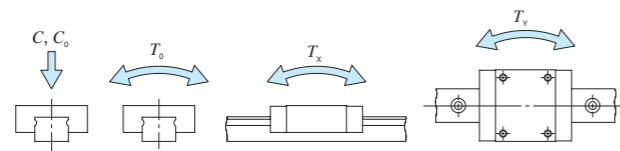

### Example of identification number for assembled set

Model code	Size	Part code	Material code	Preload symbol	Class symbol	Interchangeable code	Supplemental code	
<b>MH G 20 C2 R480</b>				<b>T<sub>1</sub></b>	<b>P</b>	<b>S2</b>	<b>/D</b>	
<b>Series</b> MH Flange type, mounting from bottom	<b>Length of slide unit</b> No symbol Standard G High rigidity long	<b>Size</b> 15, 20, 25, 30, 35, 45	<b>Number of slide unit (two slide units)</b>	<b>Length of track rail (480mm)</b>	<b>Material</b> No symbol High carbon steel SL Stainless steel	<b>Preload amount</b> T <sub>0</sub> Clearance No symbol Standard T <sub>1</sub> Light preload T <sub>2</sub> Medium preload T <sub>3</sub> Heavy preload	<b>Interchangeable code</b> S2 Interchangeable specification No symbol Non interchangeable specification	<b>Special specification</b> A, D, E, F, I, J, L, LF, MA, MN, N, PS, T, V, W, Z
						<b>Accuracy class</b> H High P Precision SP Super precision		

In case ordering track rail only, model code is changed as shown below.  
Track rail of interchangeable MH → Model code LWH (Ex: LWH25R480BPS2)

1N=0.102kgf=0.2248lbs.  
1mm=0.03937inch

# IKO C-Sleeve Linear Way MH

Flange type,  
mounting from bottom

Standard : MHT  
High rigidity long : MHTG

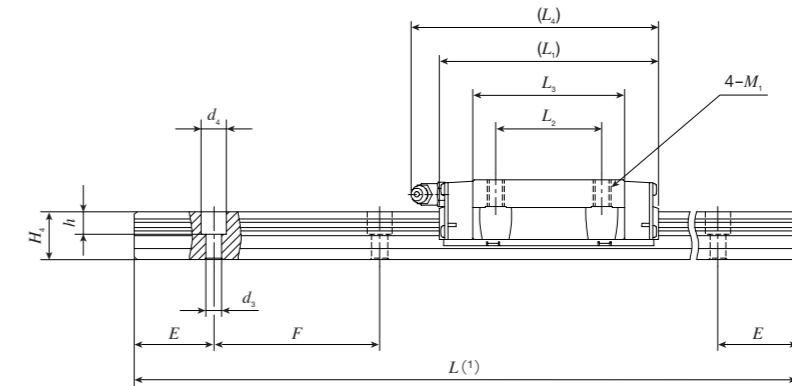
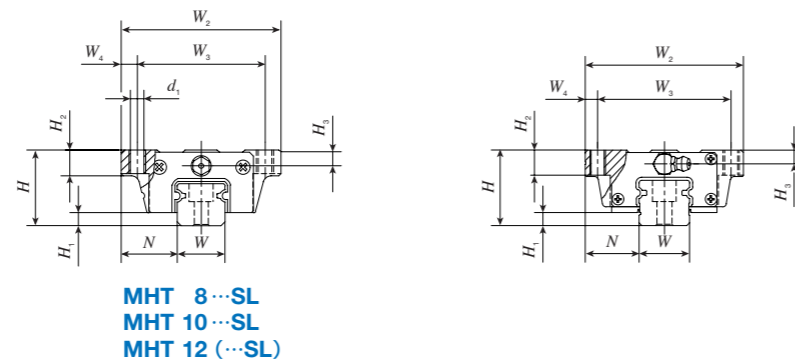

Model number	Interchangeable	Mass (Reference)		Dimension of assembly mm			Dimension of slide unit mm											Dimension of track rail mm							Recommended mounting bolt for track rail mm Bolt size × length	Basic <sup>(3)</sup> dynamic load rating C N	Basic <sup>(3)</sup> static load rating C <sub>0</sub> N	Static moment rating <sup>(3)</sup>			Model number
		Slide unit kg	Track rail kg/m	H	H <sub>1</sub>	N	W <sub>2</sub>	W <sub>3</sub>	W <sub>4</sub>	L <sub>1</sub>	L <sub>2</sub>	L <sub>3</sub>	L <sub>4</sub>	d <sub>1</sub> <sup>(4)</sup>	M <sub>1</sub>	H <sub>2</sub>	H <sub>3</sub>	W	H <sub>4</sub>	d <sub>3</sub>	d <sub>4</sub>	h	E	F				T <sub>0</sub> N·m	T <sub>x</sub> N·m	T <sub>y</sub> N·m	
MHT 8...SL	☆	0.015	0.32	10	2.1	8	24	19	2.5	24	10	15.3	-	1.9	M 2.3	3.5	2	8	6	2.4	4.2	2.3	10	20	M 2 × 8	1 510	2 120	8.8	5.5 32.0	4.7 26.9	MHT 8...SL
MHT 10...SL	☆	0.031	0.47	12	2.4	10	30	24	3	32	12	21.4	-	2.6	M 3	4.5	2.5	10	7	3.5	6	3.5	12.5	25	M 3 × 8	2 640	3 700	19.2	13.3 73.8	11.1 61.9	MHT 10...SL
MHT 12	☆	0.108	0.86	19	3.2	14	40	32	4	46	15	31.6	50	3.4	M 4	6	4	12	10.5	3.5	6	4.5	20	40	M 3 × 12	6 260	8 330	51.6	44.7 237	37.5 199	MHT 12
MHT 12...SL	☆																														MHT 12...SL
MHT 15	☆	0.22	1.47	24	4.5	16	47	38	4.5	66	30	44.2	69	-	M 5	7	4.5	15	15	4.5	8	6	30	60	M 4 × 16	11 600	13 400	112	95.6 556	95.6 556	MHT 15
MHT 20	☆	0.47	2.56	30	5	21.5	63	53	5	83	40	56	95	-	M 6	10	5.5	20	18	6	9.5	8.5	30	60	M 5 × 18	18 100	21 100	232	195 1 090	195 1 090	MHT 20
MHTG 20	☆	0.69								112		84.8	124													24 100	31 700	349	421 2 140	421 2 140	MHTG 20
MHT 25	☆	0.69	3.50	36	6.5	23.5	70	57	6.5	95	45	63.9	106	-	M 8	10	6.5	23	22	7	11	9	30	60	M 6 × 22	25 200	28 800	362	309 1 690	309 1 690	MHT 25
MHTG 25	☆	0.91								118		86.6	129													30 800	38 300	483	533 2 740	533 2 740	MHTG 25
MHT 30	☆	1.28	4.82	42	7	31	90	72	9	113	52	80.6	124	-	M10	10	8	28	25	9	14	12	40	80	M 8 × 28	35 400	40 700	623	536 2 820	536 2 820	MHT 30
MHTG 30	☆	1.69								139		106.6	150													42 700	53 200	814	894 4 460	894 4 460	MHTG 30
MHT 35	☆	1.79	6.85	48	8	33	100	82	9	123	62	86.2	135	-	M10	13	10	34	28	9	14	12	40	80	M 8 × 28	48 700	53 700	823	631 3 480	579 3 190	MHT 35
MHTG 35	☆	2.35								151		114	163													59 500	71 600	1 100	1 090 5 570	1 000 5 110	MHTG 35
MHT 45	☆	3.17	10.7	60	10	37.5	120	100	10	147	80	103.4	158	-	M12	15	13	45	34	14	20	17	52.5	105	M12 × 35	74 600	80 200	1 610	1 150 6 190	1 060 5 690	MHT 45
MHTG 45	☆	4.34								190		146.6	201													95 200	114 000	2 280	2 240 11 100	2 050 10 200	MHTG 45

Note (1) : Track rail lengths L are shown in Table 29.4.

(2) : Track rail mounting bolts are not appended. Hexagon socket bolts of JIS B 1176 strength division 12.9 or equivalent are recommended.

(3) : The directions of basic dynamic load rating (C), basic static load rating (C<sub>0</sub>) and static moment rating (T<sub>0</sub>, T<sub>x</sub> and T<sub>y</sub>) are shown in the sketches below.

The upper values in the T<sub>x</sub> and T<sub>y</sub> column apply to one slide unit, and the lower values apply to two units in close contact.

(4) : MHT8...SL, MHT10...SL, MHT12 and MHT12...SL can be mounted also from bottom direction.

Remark : Oil hole is provided for size 8 and 10 models.

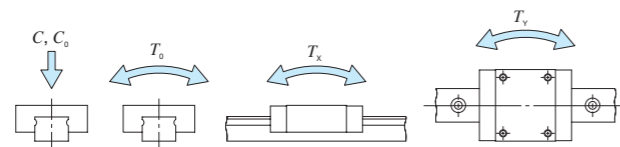

### Example of identification number for assembled set

Model code	Size	Part code	Material code	Preload symbol	Class symbol	Interchangeable code	Supplemental code	
<b>MHT G</b>	<b>20</b>	<b>C2 R480</b>		<b>T<sub>1</sub></b>	<b>P</b>	<b>S2</b>	<b>/D</b>	
<b>Series</b> MHT Flange type, mounting from bottom	<b>Length of slide unit</b> No symbol Standard G High rigidity long	<b>Size</b> 8, 10, 12, 15, 20, 25, 30, 35, 45	<b>Number of slide unit (two slide units)</b>	<b>Length of track rail (480mm)</b>	<b>Material</b> No symbol High carbon steel SL Stainless steel	<b>Preload amount</b> T <sub>0</sub> Clearance No symbol Standard T <sub>1</sub> Light preload T <sub>2</sub> Medium preload T <sub>3</sub> Heavy preload	<b>Interchangeable code</b> S2 Interchangeable specification No symbol Non interchangeable specification	<b>Special specification</b> A, D, E, F, I, J, L, LF, MA, MN, N, PS, T, V, W, Z
						<b>Accuracy class</b> H High P Precision SP Super precision		

In case ordering track rail only, model code is changed as shown below.

Track rail of interchangeable MH → Model code LWH (Ex: LWH25R480BPS2)

1N=0.102kgf=0.2248lbs.

1mm=0.03937inch

# IKO C-Sleeve Linear Way MH

Block type,  
mounting from top

Short : MHDC  
Standard : MHD  
High rigidity long : MHDG

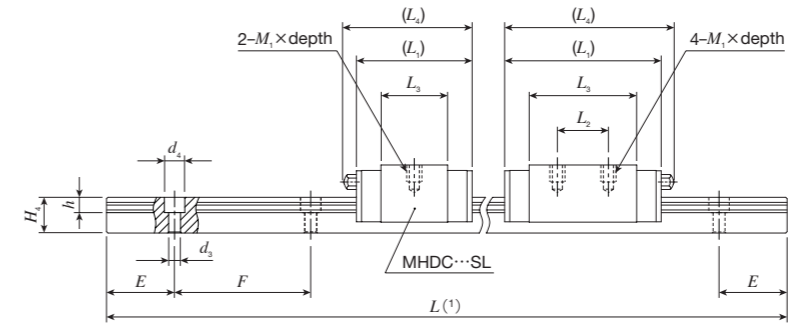
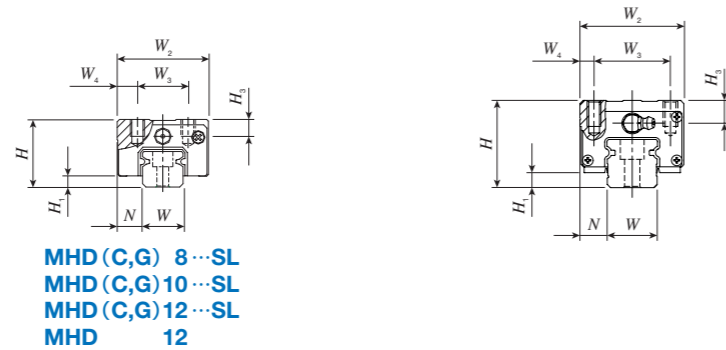

Model number	Interchangeable	Mass (Reference)		Dimension of assembly mm			Dimension of slide unit mm							Dimension of track rail mm							Recommended mounting bolt for track rail mm Bolt size × length	Basic <sup>(3)</sup> dynamic load rating C	Basic <sup>(3)</sup> static load rating C <sub>0</sub>	Static moment rating <sup>(3)</sup>			Model number		
		Slide unit kg	Track rail kg/m	H	H <sub>1</sub>	N	W <sub>2</sub>	W <sub>3</sub>	W <sub>4</sub>	L <sub>1</sub>	L <sub>2</sub>	L <sub>3</sub>	L <sub>4</sub>	M <sub>1</sub> × depth	H <sub>3</sub>	W	H <sub>4</sub>	d <sub>3</sub>	d <sub>4</sub>	h				E	F	T <sub>0</sub>		T <sub>x</sub>	T <sub>y</sub>
MHDC 8...SL	☆	0.008	0.32	11	2.1	4	16	10	3	18	-	9.0	-	M 2 × 2.5	3	8	6	2.4	4.2	2.3	10	20	M 2 × 8	1 050	1 270	5.3	2.2 15.5	1.8 13.0	MHDC 8...SL
MHD 8...SL	☆	0.013								24	10	15.3												5.5 32.0	4.7 26.9	MHD 8...SL			
MHDG 8...SL	☆	0.018								30.5	21.7	10.4 55.4												8.8 46.4	MHDG 8...SL				
MHDC 10...SL	☆	0.018	0.47	13	2.4	5	20	13	3.5	24	-	13.4	-	M 2.6 × 3	3.5	10	7	3.5	6	3.5	12.5	25	M 3 × 8	1 920	2 350	12.2	5.8 37.1	4.8 31.2	MHDC 10...SL
MHD 10...SL	☆	0.026								32	12	21.4												13.3 73.8	11.1 61.9	MHD 10...SL			
MHDG 10...SL	☆	0.035								40	29.4	23.8 123												20.0 103	MHDG 10...SL				
MHDC 12...SL	☆	0.057	0.86	20	3.2	7.5	27	15	6	34	-	19.6	38	M 4 × 5	5	12	10.5	3.5	6	4.5	20	40	M 3 × 12	4 560	5 300	32.8	19.4 117	16.3 98.5	MHDC 12...SL
MHD 12...SL	☆	0.089								46	15	31.6	50											44.7 237	37.5 199	MHD 12...SL			
MHDG 12...SL	☆	0.115								58	43.6	62	80.4 399											67.5 335	MHDG 12...SL				
MHD 15	☆	0.23	1.47	28	4.5	9.5	34	26	4	66	26	44.2	69	M 4 × 10	8.5	15	15	4.5	8	6	30	60	M 4 × 16	11 600	13 400	112	95.6 556	95.6 556	MHD 15
MHD 25	☆	0.64	3.50	40	6.5	12.5	48	35	6.5	95	35	63.9	106	M 6 × 12	10.5	23	22	7	11	9	30	60	M 6 × 22	25 200	28 800	362	309 1 690	309 1 690	MHD 25
MHDG 25	☆	0.78								118	50	86.6	129											533 2 740	533 2 740	MHDG 25			
MHD 30	☆	1.12	4.82	45	7	16	60	40	10	113	40	80.6	124	M 8 × 16	11	28	25	9	14	12	40	80	M 8 × 28	35 400	40 700	623	536 2 820	536 2 820	MHD 30
MHDG 30	☆	1.44								139	60	106.6	150											894 4 460	894 4 460	MHDG 30			
MHD 35	☆	1.74	6.85	55	8	18	70	50	10	123	50	86.2	135	M 8 × 16	17	34	28	9	14	12	40	80	M 8 × 28	48 700	53 700	823	631 3 480	579 3 190	MHD 35
MHDG 35	☆	2.26								151	72	114	163											1 090 5 570	1 000 5 110	MHDG 35			
MHD 45	☆	3.30	10.7	70	10	20.5	86	60	13	147	60	103.4	158	M10 × 20	23	45	34	14	20	17	52.5	105	M12 × 35	74 600	80 200	1 610	1 150 6 190	1 060 5 690	MHD 45
MHDG 45	☆	4.57								190	80	146.6	201											2 240 11 100	2 050 10 200	MHDG 45			

Note (1): Track rail lengths L are shown in Table 29.4.

(2): Track rail mounting bolts are not appended. Hexagon socket bolts of JIS B 1176 strength division 12.9 or equivalent are recommended.

(3): The directions of basic dynamic load rating (C), basic static load rating (C<sub>0</sub>) and static moment rating (T<sub>0</sub>, T<sub>x</sub> and T<sub>y</sub>) are shown in the sketches below.

The upper values in the T<sub>x</sub> and T<sub>y</sub> column apply to one slide unit, and the lower values apply to two units in close contact.

Remark: Oil hole is provided for size 8 to 10 models.

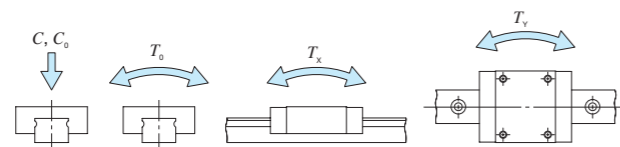

### Example of identification number for assembled set

Model code: MHD G 20 C2 R480 T1 P S2 /D

Size: 20  
Part code: C2 R480  
Material code: T1  
Preload symbol: P  
Class symbol: S2  
Interchangeable code: /D  
Supplemental code: /D

Series	Interchangeable code	Special specification
MHD Block type, mounting from top	S2 Interchangeable specification	A, D, E, F, I, J, L, LF, MA, MN, N, PS, T, U, V, W, Z
Length of slide unit	Preload amount	Accuracy class
C Short No symbol Standard G High rigidity long	T0 Clearance No symbol Standard T1 Light preload T2 Medium preload T3 Heavy preload	H High P Precision SP Super precision
Size	Material	
8, 10, 12, 15, 25, 30, 35, 45	No symbol High carbon steel SL Stainless steel	
Number of slide unit (two slide units)		
Length of track rail (480mm)		

In case ordering track rail only, model code is changed as shown below.

Track rail of interchangeable MH → Model code LWH (Ex: LWH25R480BPS2)

1N=0.102kgf=0.2248lbs.

1mm=0.03937inch



# IKO C-Sleeve Linear Way MH

Compact block type,  
mounting from top

Standard : MHS  
High rigidity long : MHSG

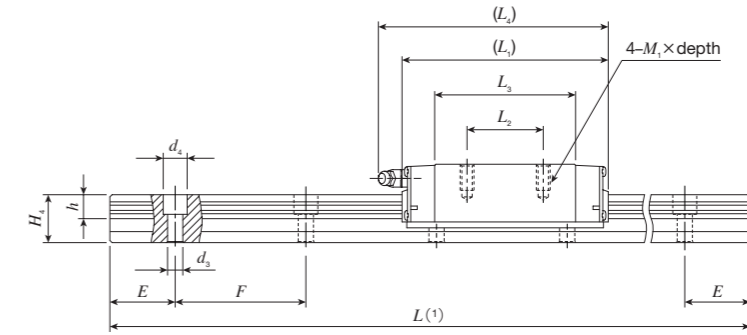
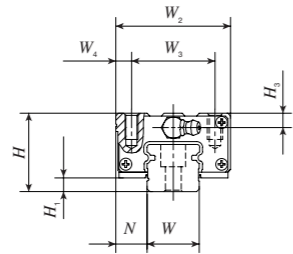

Model number	Interchangeable	Mass (Reference)		Dimension of assembly mm			Dimension of slide unit mm							Dimension of track rail mm							Recommended mounting bolt for track rail mm Bolt size × length	Basic <sup>(3)</sup> dynamic load rating C N	Basic <sup>(3)</sup> static load rating C <sub>0</sub> N	Static moment rating <sup>(3)</sup>			Model number		
		Slide unit kg	Track rail kg/m	H	H <sub>1</sub>	N	W <sub>2</sub>	W <sub>3</sub>	W <sub>4</sub>	L <sub>1</sub>	L <sub>2</sub>	L <sub>3</sub>	L <sub>4</sub>	M <sub>1</sub> × depth	H <sub>3</sub>	W	H <sub>4</sub>	d <sub>3</sub>	d <sub>4</sub>	h				E	F	T <sub>0</sub> N·m		T <sub>x</sub> N·m	T <sub>y</sub> N·m
MHS 15	☆	0.18	1.47	24	4.5	9.5	34	26	4	66	26	44.2	69	M4 × 8	4.5	15	15	4.5	8	6	30	60	M4 × 16	11 600	13 400	112	95.6 556	95.6 556	MHS 15
MHS 20	☆	0.35	2.56	30	5	12	44	32	6	83	36	56	95	M5 × 10	5.5	20	18	6	9.5	8.5	30	60	M5 × 18	18 100	21 100	232	195 1 090	195 1 090	MHS 20
MHSG 20	☆	0.52								112	50	84.8	124											24 100	31 700	349	421 2 140	421 2 140	MHSG 20
MHS 25	☆	0.54	3.50	36	6.5	12.5	48	35	6.5	95	35	63.9	106	M6 × 12	6.5	23	22	7	11	9	30	60	M6 × 22	25 200	28 800	362	309 1 690	309 1 690	MHS 25
MHSG 25	☆	0.66								118	50	86.6	129											30 800	38 300	483	533 2 740	533 2 740	MHSG 25
MHS 30	☆	1.00	4.82	42	7	16	60	40	10	113	40	80.6	124	M8 × 16	8	28	25	9	14	12	40	80	M8 × 28	35 400	40 700	623	536 2 820	536 2 820	MHS 30
MHSG 30	☆	1.29								139	60	106.6	150											42 700	53 200	814	894 4 460	894 4 460	MHSG 30

Note (1) : Track rail lengths L are shown in Table 29.4.

(2) : Track rail mounting bolts are not appended. Hexagon socket bolts of JIS B 1176 strength division 12.9 or equivalent are recommended.

(3) : The directions of basic dynamic load rating (C), basic static load rating (C<sub>0</sub>) and static moment rating (T<sub>0</sub>, T<sub>x</sub> and T<sub>y</sub>) are shown in the sketches below.  
The upper values in the T<sub>x</sub> and T<sub>y</sub> column apply to one slide unit, and the lower values apply to two units in close contact.

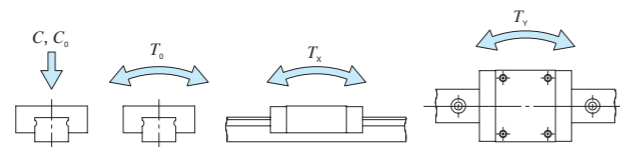

### Example of identification number for assembled set

Model code	Size	Part code	Preload symbol	Class symbol	Interchangeable code	Supplemental code
MHS	G	30	C2	R480	T1	P S2 /D
<b>Series</b>	<b>Length of slide unit</b>	<b>Size</b>	<b>Number of slide unit (two slide units)</b>	<b>Length of track rail (480mm)</b>	<b>Interchangeable code</b>	<b>Special specification</b>
MHS Compact block type, mounting from top	No symbol Standard G High rigidity long	15, 20, 25, 30			S2 Interchangeable specification No symbol Non interchangeable specification	A, D, E, F, I, J, L, LF, MA, MN, N, PS, T, U, V, W, Z
					<b>Preload amount</b>	<b>Accuracy class</b>
					No symbol Standard T1 Light preload T2 Medium preload T3 Heavy preload	H High P Precision SP Super precision

In case ordering track rail only, model code is changed as shown below.  
Track rail of interchangeable MH → Model code LWH (Ex: LWH25R480BPS2)

1N=0.102kgf=0.2248lbs.  
1mm=0.03937inch

# IKO C-Sleeve Linear Way MUL Miniature type

## MUL

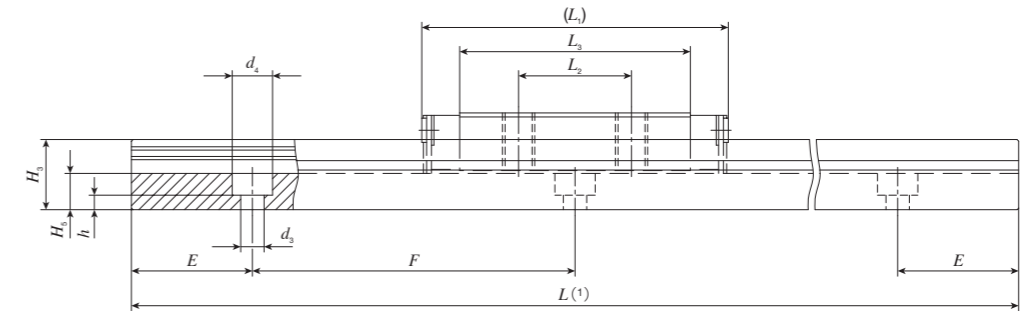
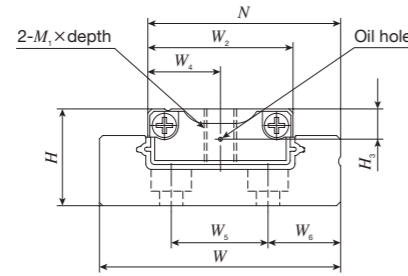

Model number	Mass (Reference) g		Dimension of assembly mm		Dimension of slide unit mm							Dimension of track rail mm						Recommended <sup>(2)</sup> mounting bolt for track rail mm Bolt size × length	Basic dynamic load rating C N	Basic static load rating C <sub>0</sub> N	Static moment rating <sup>(3)</sup> N·m			Model number				
	Slide unit	Track rail (per 100mm)	H	N	W <sub>2</sub>	W <sub>4</sub>	L <sub>1</sub>	L <sub>2</sub>	L <sub>3</sub>	M <sub>1</sub> × depth	H <sub>3</sub>	W	H <sub>4</sub>	H <sub>5</sub>	W <sub>5</sub>	W <sub>6</sub>	d <sub>3</sub>				d <sub>4</sub>	h	E		F	T <sub>0</sub>	T <sub>x</sub>	T <sub>y</sub>
MUL 25	13	87	9	19.4	14	7	31	12	22	M3 × 5	2.9	24.9	6.7	3.2	9	8	2.9	4.8	1.6	17.5	35	Cross-recessed head screw for precision equipment M2.5 × 6	1 770	2 840	20.3	10.1 53.7	8.4 45.0	MUL 25
MUL 30	28	139	12	23.9	18	9	38	14	28.6	M4 × 7	3.75	29.9	8.7	4.5	12	9	2.9	5	2.7	20	40	Hexagon socket head bolt M2.5 × 6	2 280	3 810	34.9	16.9 87.5	14.2 73.4	MUL 30

Note (1) : Track rail lengths *L* are shown in Table 29.5.

(2) : Track rail mounting bolts are not appended. In case recommended bolts are required, please indicate "/MA" onto the identification number.

(3) : The directions of basic dynamic load rating (*C*), basic static load rating (*C*<sub>0</sub>) and static moment rating (*T*<sub>0</sub>, *T*<sub>x</sub> and *T*<sub>y</sub>) are shown in the sketches below. The upper values in the *T*<sub>x</sub> and *T*<sub>y</sub> column apply to one slide unit, and the lower values apply to two units in close contact.

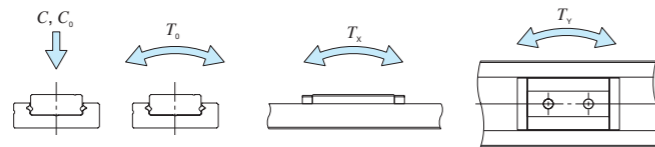

### Example of identification number for assembled set

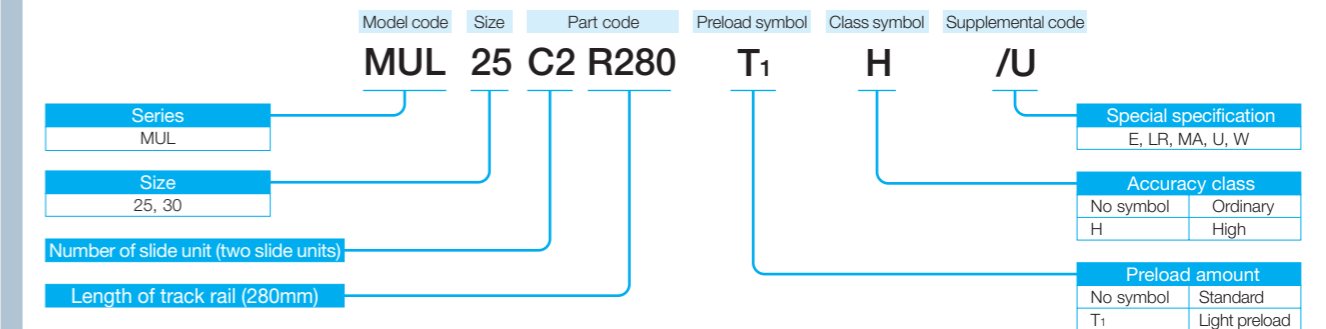

# World Network of **IKO**

## **NIPPON THOMPSON CO., LTD.**

Head office : 19-19 Takanawa 2-chome Minato-ku,  
Tokyo 108-8586, Japan  
Phone : +81 (0)3-3448-5850  
Fax : +81 (0)3-3447-7637  
E-mail : ntt@ikonet.co.jp  
URL : <http://www.ikonet.co.jp/eg/>  
Plant : Gifu, Kamakura

## **NIPPON THOMPSON CO., LTD.**

### **ASEAN REPRESENTATIVE OFFICE**

586 Luang Road, Pomprab  
Pomprab Satrupai, Bangkok  
Thailand 10100  
Phone: +66 (0)-2623-3699  
Fax: +66 (0)-2623-0716  
E-mail: [iko@anet.net.th](mailto:iko@anet.net.th)

## **IKO-THOMPSON (SHANGHAI) LTD.**

Room 23G, Zhao Feng World Trade Building  
No.369, Jiang Su Road,  
Changning District, Shanghai 200050,  
People's Republic of China  
Phone: +86 (0)21-5237-9100  
Fax: +86 (0)21-5237-9095

## **IKO INTERNATIONAL, INC.**

### **East coast**

91 Walsh Drive  
Parsippany, NJ 07054  
U.S.A.  
Phone: +1 973-402-0254  
Toll Free: 1-800-922-0337  
Fax: +1 973-402-0441  
E-mail: [eco@ikonet.co.jp](mailto:eco@ikonet.co.jp)

### **Midwest**

500 East Thorndale Avenue  
Wood Dale, IL 60191  
U.S.A.  
Phone: +1 630-766-6464  
Toll Free: 1-800-323-6694  
Fax: +1 630-766-6869  
E-mail: [mwo@ikonet.co.jp](mailto:mwo@ikonet.co.jp)

### **West coast**

20170 South Western Avenue  
Torrance, CA 90501  
U.S.A.  
Phone: +1 310-609-3988  
Toll Free: 1-800-252-3665  
Fax: +1 310-609-3916  
E-mail: [wco@ikonet.co.jp](mailto:wco@ikonet.co.jp)

### **Southeast**

2150 Boggs Road, Suite 100  
Duluth, GA 30096  
U.S.A.  
Phone: +1 770-418-1904  
Toll Free: 1-800-874-6445  
Fax: +1 770-418-9403  
E-mail: [seo@ikonet.co.jp](mailto:seo@ikonet.co.jp)

### **Southwest**

8105 N. Beltline Road  
Suite 130, Irving, TX 75063  
U.S.A.  
Phone: +1 972-929-1515  
Toll Free: 1-800-295-7886  
Fax: +1 972-915-0060  
E-mail: [sw@ikonet.co.jp](mailto:sw@ikonet.co.jp)

## **NIPPON THOMPSON EUROPE B.V.**

### **The Netherlands**

Sheffieldstraat 35-39  
3047 AN Rotterdam  
The Netherlands  
Phone: +31 (0)10-4626868  
Fax: +31 (0)10-4626099  
E-mail: [nte@ikonet.co.jp](mailto:nte@ikonet.co.jp)

### **Germany**

Mündelheimer Weg 56  
40472 Düsseldorf  
Germany  
Phone: +49 (0)211-414061  
Fax: +49 (0)211-427693  
E-mail: [ntd@ikonet.co.jp](mailto:ntd@ikonet.co.jp)

Im Gewerbepark D 30  
93059 Regensburg  
Germany  
Phone: +49 (0)941-206070  
Fax: +49 (0)941-2060719  
E-mail: [ntdr@iko-nt.de](mailto:ntdr@iko-nt.de)

Gruben Str.95c  
66540 Neunkirchen  
Germany  
Phone: +49 (0)6821-999-860  
Fax: +49 (0)6821-999-8626  
E-mail: [ntdn@iko-nt.de](mailto:ntdn@iko-nt.de)

### **UK**

2 Vincent Avenue, Crownhill  
Milton Keynes Bucks MK8 0AB  
United Kingdom  
Phone: +44 (0)1908-566144  
Fax: +44 (0)1908-565458  
E-mail: [sales@iko.co.uk](mailto:sales@iko.co.uk)

### **Spain**

Autovia Madrid-Barcelona, Km. 43,700  
Polig. Ind. AIDA, A-8, Ofic. 2, 1<sup>a</sup>  
19200-Azuqueca de Henares  
Guadalajara, Spain  
Phone: +34 949-263390  
Fax: +34 949-263113  
E-mail: [nts@ikonet.co.jp](mailto:nts@ikonet.co.jp)

### **France**

Roissypole Le Dôme  
2 rue de La Haye  
BP 15950 Tremblay en France  
95733 Roissy C. D. G. Cedex  
France  
Phone: +33 (0)1-48165739  
Fax: +33 (0)1-48165746  
E-mail: [ntf@ikonet.co.jp](mailto:ntf@ikonet.co.jp)

Recognizing that conservation of the global environment is the top-priority challenge for the world's population, Nippon Thompson will conduct its activities with consideration of the environment as a corporate social responsibility, reduce its negative impact on the environment, and help foster a rich global environment.

**ISO 9001 & 14001 Quality system  
registration certificate**

