

FORMSPRAG® CLUTCH



**CSK
One Way
Bearing
Clutches**

Formsprag
Clutch

Formsprag

Overrunning Indexing and Backstopping Clutches

Formsprag and Stieber have been designing, manufacturing and delivering dependable, long-lived, precision power transmission products for over 50 years, providing one of the broadest lines of overrunning clutches in the world.

Formsprag and Stieber overrunning clutches deliver thoroughly proven, dependable power transmission. Careful selection of highest quality materials, precision manufacturing by experienced craftsmen, conscientious assembly, and rigid adherence to detail guarantee a reliable, quality product.

Overrunning clutches handle torque loads up to 700,000 lb.ft. (949200 Nm). Other sizes and designs are available by special order.



CSK Series Clutches
Bearing envelope (62 series) design sprag clutches for overrunning, indexing and backstopping applications.

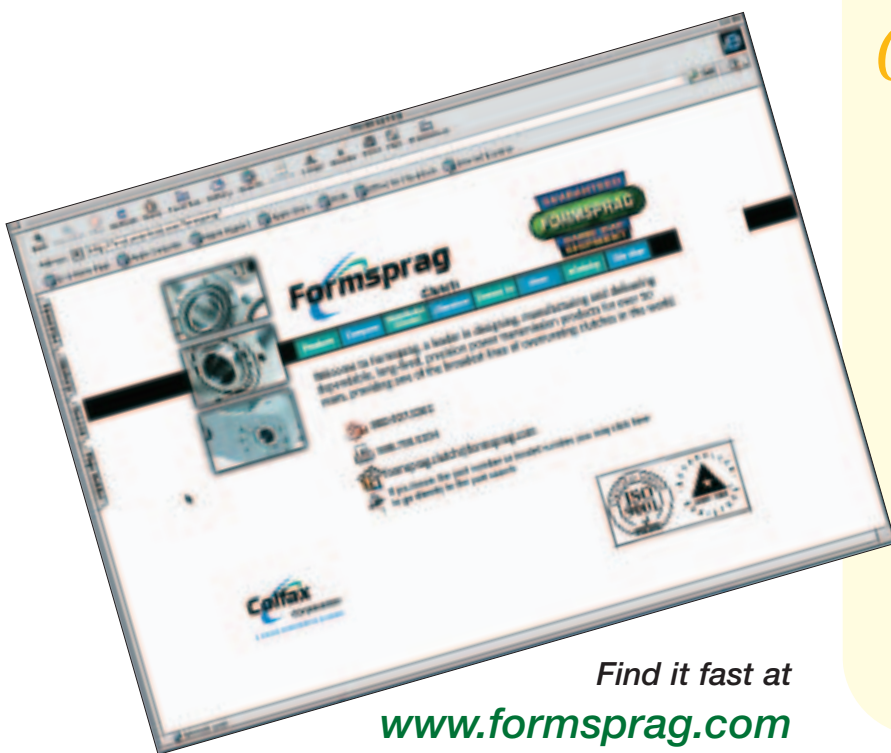

Find it fast at
www.formsprag.com

Check Out **formsprag.com**

Use our online interactive eCatalog to find what you need just in a few clicks. Input your application requirements using many helpful aids to identify performance criteria. And the right product will power its way to the top of the list.

- Exclusive "Competitor Interchange" feature lets you enter a competitor part number and find the specific replacement Formsprag model
- Fill out the Application Data Form to get assistance in determining your selection
- Submit an online RFQ to the distributor of your choice.

CSK

Type CSK is a sprag type clutch integrated into a 62 Series ball bearing (except sizes 8 and 40). It is bearing supported, shipped grease lubricated and protected against dust larger than .012" (.3mm) diameter. The use of additional "nylos" type seals is recommended especially when the working temperature exceeds 122°F (50°C).

Oil bath lubrication is also possible if the original grease is first flushed out using a suitable solvent.

Torque transmission is ensured by a press fit assembly into a rigid outer housing with N6 tolerance, and onto a shaft with n6 tolerance. The initial bearing radial clearance is set at C5, and is reduced if using the press fit as specified.

One race may be glued. If both races are to be glued, performance will be reduced or a C3 bearing clearance will be necessary.

Operating temperature range: -40°F (-40°C) to 212°F (+100°C). Peaks up to 248°F (+120°C) are acceptable for short periods.

CSK..2RS

CSK..2RS clutches are .197" (5mm) wider than a standard 62 Series bearing, as they are equipped with lip seals for washdown applications.

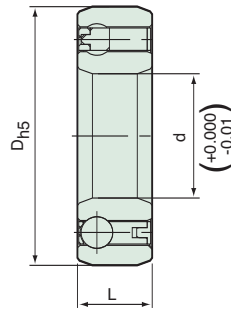

Dimensions inches (mm)

Size	Bearing Series	CSK		CSK..2RS		d Bore Sizes
		D_{h5} in (mm)	L in (mm)	L in (mm)		
8		0.87 (22)	.035 (9)	.035 (9)	0.31 (8)	
12	6201	1.26 (32)	0.39 (10)	0.55 (14)	0.47 (12)	
15	6202	1.38 (35)	0.43 (11)	0.63 (16)	0.59 (15)	
17	6203	1.57 (40)	0.47 (12)	0.67 (17)	0.67 (17)	
20	6204	1.85 (47)	0.55 (14)	0.75 (19)	0.79 (20)	
25	6205	2.05 (52)	0.59 (15)	0.79 (20)	0.98 (25)	
30	6206	2.44 (62)	0.63 (16)	0.83 (21)	1.18 (30)	
35	6207	2.83 (72)	0.67 (17)	0.87 (22)	1.38 (35)	
40		3.15 (80)	0.87 (22)	1.06 (27)	1.57 (40)	

* CSK..2RS has only one lip seal on ball bearing side.

Specifications inches (metric)

Size	Bearing Series	Torque Capacity	Max. Overrunning Speed	Resistance after run-in	Bearing Loads		Shipping Weight	
					CSK	CSK	CSK	CSK..2RS
		lb.ft. (Nm)	RPM	Dynamic lb.in. (Ncm)	Dynamic lb (kN)	Static lb (kN)	lb (kg)	lb (kg)
8*		2.4 (3.5)	15,000	0.44 (0.5)	738 (3.28)	193.5 (0.86)	0.03 (0.015)	0.03 (0.015)
12	6201	8.8 (12)	10,000	0.62 (0.7)	1372.5 (6.1)	623.25 (2.77)	0.09 (0.04)	0.11 (0.05)
15	6202	14.7 (20)	8,400	0.80 (0.9)	1665 (7.4)	769.5 (3.42)	0.13 (0.06)	0.15 (0.07)
17	6203	30 (40)	7,350	0.97 (1.1)	1777.5 (7.9)	855 (3.8)	0.15 (0.07)	0.20 (0.09)
20	6204	50 (68)	6,000	1.15 (1.3)	2115 (9.4)	1003.5 (4.46)	0.24 (0.11)	0.32 (0.145)
25	6205	77 (105)	5,200	1.77 (2)	2407.5 (10.7)	1228.5 (5.46)	0.31 (0.14)	0.39 (0.175)
30	6206	133 (180)	4,200	3.89 (4.4)	2632.5 (11.7)	1451.25 (6.45)	0.46 (0.21)	0.60 (0.27)
35	6207	177 (240)	3,600	5.13 (5.8)	2835 (12.6)	1638 (7.28)	0.66 (0.3)	0.88 (0.4)
40		284 (385)	3,000	6.20 (7)	3496.5 (15.54)	2756.25 (12.25)	1.10 (0.5)	1.32 (0.6)

* CSK..2RS has only one lip seal on ball bearing side.

The torque ratings are based upon 1 million load cycles at full catalog torque, which is a standard in the North American Industrial Market.

CSK Series Clutches

CSK..P

CSK..P has the same construction and outside dimensions as type CSK, but has a keyway on the inner race.

These clutches can be mounted with a slip fit on a shaft to k6 tolerance.

The outer race must be pressed into a rigid housing to N6 tolerance.

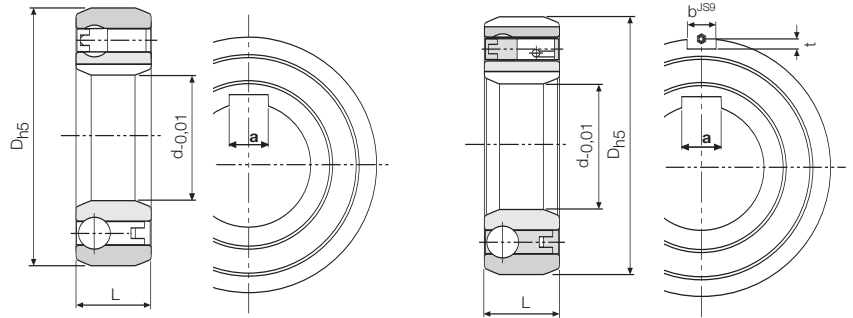

CSK..P
Single Keyway

CSK..PP
Dual Keyways

CSK..P-2RS

CSK..P-2RS clutches are .197" (5mm) wider than a standard 62 Series bearing, as they are equipped with lip seals for washdown applications.

CSK..PP

CSK..PP features a keyway on both the inner and outer race. The recommended mounting tolerances are k6 on the shaft and K6 in a rigid housing. An h6 tolerance on the shaft or H6 in the housing are also acceptable for a light press fit assembly.

Operating temperature range: -40°F (-40°C) to 212°F (+100°C). Peaks up to 248°F (+120°C) are acceptable for short periods. Please contact us for higher temperatures.

Dimensions inches (millimeters)

Size	Bearing Series	L		d		a		
		CSK..P	CSK..P-2RS	Bore Size	Keyseat			
		D _{h5} in (mm)	b in (mm)	t in (mm)				
15	6202	1.38 (35)	0.43 (11)	—	.08 (2)	.02 (0.6)	0.59 (15)	(5 X 1.2)
17	6203	1.57 (40)	0.47 (12)	—	.08 (2)	.04 (1.0)	0.67 (17)	(5 X 1.2)
20	6204	1.85 (47)	0.55 (14)	.075 (19)	.12 (3)	.06 (1.5)	0.79 (20)	(6 X 1.6)
25	6205	2.05 (52)	0.59 (15)	0.78 (20)	.24 (6)	.08 (2.0)	0.98 (25)	(8 X 2)
30	6206	2.44 (62)	0.63 (16)	0.82 (21)	.24 (6)	.08 (2.0)	1.18 (30)	(8 X 2)
35	6207	2.83 (72)	0.67 (17)	—	.31 (8)	.10 (2.5)	1.38 (35)	(10 X 2.4)
40	—	3.15 (80)	0.87 (22)	—	.39 (10)	.12 (3.0)	1.57 (40)	(12 X 3.3)

For keyseat sizes CSK 15–35 use DIN 6885.3.

For size 40 use DIN 6885.1 table on page 127 in catalog P-956.

Specifications inches (metric)

Size	Bearing Series	Torque Capacity	Max. Overrunning Speed	Resistance after run-in	Bearing Loads		Shipping Weight	
					Dynamic	Static	CSK..P	CSK..P-2RS
		lb.ft. (Nm)	RPM	lb.in. (Ncm)	lb (kN)	lb (kN)	lb (kg)	lb (kg)
15	6202	14.7 (20)	8,400	0.80 (0.9)	1665 (7.4)	769.5 (3.42)	0.13 (0.06)	—
17	6203	30 (40)	7,350	0.97 (1.1)	1777.5 (7.9)	855 (3.8)	0.15 (0.07)	—
20	6204	50 (68)	6,000	1.15 (1.3)	2115 (9.4)	1003.5 (4.46)	0.24 (0.11)	0.24 (0.11)
25	6205	77 (105)	5,200	1.77 (2)	2407.5 (10.7)	1228.5 (5.46)	0.31 (0.14)	0.31 (0.14)
30	6206	133 (180)	4,200	3.89 (4.4)	2632.5 (11.7)	1451.25 (6.45)	0.46 (0.21)	0.46 (0.21)
35	6207	177 (240)	3,600	5.13 (5.8)	2836 (12.6)	1638 (7.28)	0.66 (0.3)	—
40	—	284 (325)	3,000	6.20 (7)	3496.5 (15.54)	2756.25 (12.25)	1.10 (0.5)	—

* Only one lip seal on ball bearing side.

The torque ratings are based upon 1 million load cycles at full catalog torque, which is a standard in the North American Industrial Market.

CSK Advantages

Unique sprag design provides a better way to achieve a higher size for size torque rating!

Design Features

- Four different mounting designs
- Wide bore range of 8 to 40 mm
- Self-contained, compact ball bearing design
- 2RS, lip-sealed design
- No maintenance, grease lubricated for life
- High speed range from 0-15,000 RPM
- Longer wearing life with Formchromed Sprags
- 25 different designs in stock
- Wide operating temperature range from -40F to 212F (-40C to 100C)
- Outside dimensions same as 6200 Bearings Series

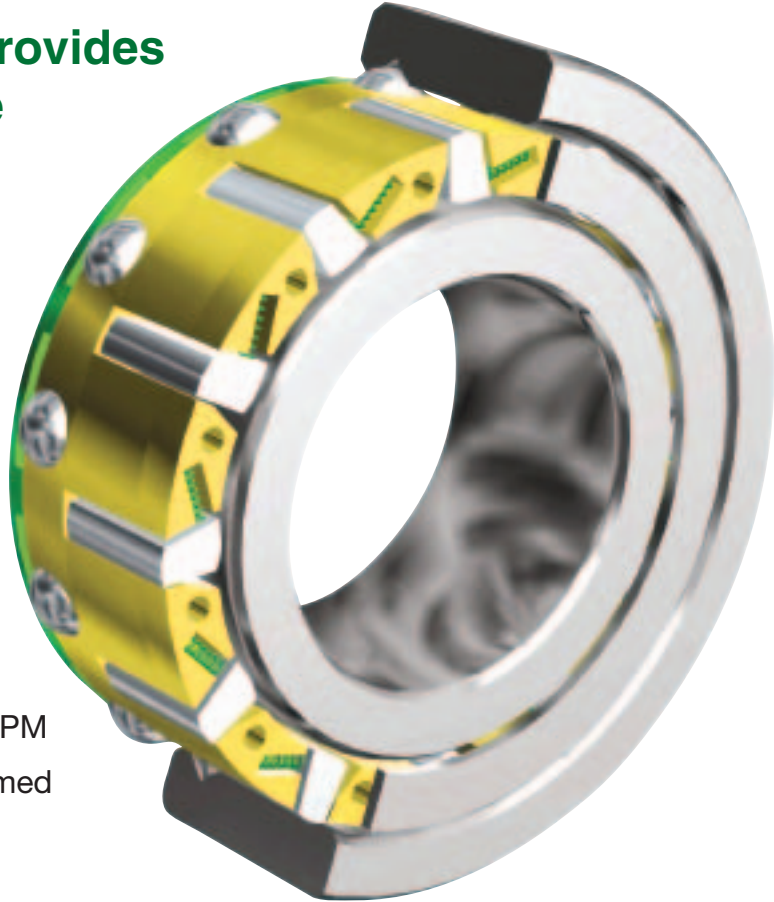

Three Mounting Configurations

Press Fit

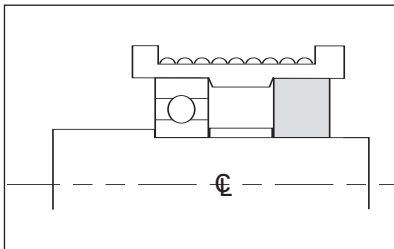

The Model CSK clutches must be mounted with a press fit on both the outer and inner races. The shaft diameter tolerance must be held to a n6. The bore of the housing for the outer race should be a N6 tolerance.

Keyseated Clutch Bore

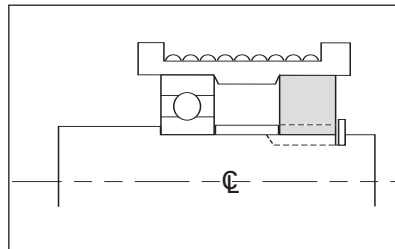

The Model CSK..P clutches with a keyseat in the bore must be secured or axially retained on the customer's shaft by customer supplied snap ring, set collar, spacer or step in shaft diameter. The CSK..P outer race is mounted with a press fit into the bore of the housing.

Keyseated In Clutch Bore & OD

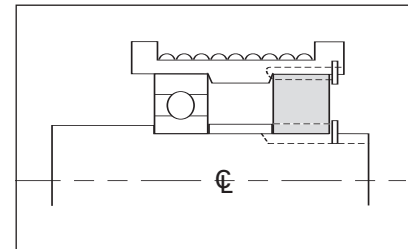

The Model CSK...PP clutches have a keyseat on both the outer and inner race. The CSK...PP clutches must be axially restrained by the use of customer supplied snap ring, set collar, spacer, etc.

COLFAX PT GROUP

Colfax Power Transmission Group

Quincy, MA 02171
617-328-3300

Warner Electric

Electromagnetic Clutches and Brakes - USA
South Beloit, IL 61080
815-389-3771

For application assistance:
1-800-825-9050

Electromagnetic Clutches and Brakes - Europe
Allonnes, France
+33 (0)2 43 43 63 63

Precision Electric Coils - USA
Columbia City, IN 46725
260-244-6183

Boston Gear

*Enclosed and Open Gearing, Electrical
and Mechanical P.T. Components*
Quincy, MA 02171
617-328-3300

For Customer Service:
1-888-999-9860

Formsprag Clutch-Stieber Clutch - USA

Overrunning Clutches and Holdbacks
Warren, MI 48089
586-758-5000

For application assistance:
1-800-927-3262

Stieber Clutch-Formsprag Clutch - Europe

Overrunning Clutches and Holdbacks
Heidelberg, Germany
+49 (0)6221 30 470

Marland Clutch

*Roller Ramp and Sprag Type
Overrunning Clutches and Backstops*
Burr Ridge, IL 60527
630-455-1752

Nuttall Gear and Delroyd Worm Gear

Worm Gear and Helical Speed Reducers
Niagara Falls, NY 14302
716-731-5180

Wichita Clutch and Industrial Clutch

*Pneumatic and Oil Immersed
Clutches and Brakes - USA*
Wichita Falls, TX 76302
940-723-3400

Pneumatic Clutches and Brakes - Europe
Bedford, UK
+44 (0)1234 350311

Ameridrives Couplings

*Gear Couplings, Mill Spindles,
Universal Joints*
Erie, PA 16512
814-480-5000

Colfax Power Transmission Group - Asia Pacific

China	852 2615 9313
Taiwan	886 2 2577 8156
Singapore	65 487 4464
Thailand	66 2 322 0481
Australia	612 9894 0133

www.formsprag.com

Formsprag
Clutch

Formsprag Clutch

23601 Hoover Road • Warren, MI 48089
586-758-5000 • Fax: 586-758-5204
formsprag.clutch@formsprag.com

For application assistance:
1-800-927-3262