



One Range, One Result, **One Name ...**



CHAINS | SPROCKETS | SHAFT FIXINGS | COUPLINGS | GEARED DRIVES | INVERTERS | MOTORS | BELTS | PULLEYS | CHAINS | SPROCKETS | SHAFT FIXINGS | COUPLINGS

Fenner[®]
THE MARK OF ENGINEERING EXCELLENCE

Drive couplings

kennis maakt het verschil

ERIKS

Fenner®

DRIVE COUPLINGS

Fenner shaft couplings range from highly resilient to totally rigid and are all precision manufactured using high quality ferrous materials and the latest polymer and composite technology.



- Fenaflex tyre couplings from 24 to 14000Nm, standard DBSE spacer variant and ATEX (Ex) approved variant
- HRC resilient, Taper Lock® couplings from 30 to 3150Nm
- Jaw couplings from 0.5 to 840 Nm with incidental misalignment capacity and quick fit spacer variant
- Rigid Taper Lock® couplings in 8 sizes up to 11000Nm

Drive Couplings Design Data Required

- Type of prime mover, or driving m/c
- Electric motor starting arrangement
- Engine or compressor inertia of both machines (MR^2 or GD^2)
- Rotational speed of prime mover
- Power rating of prime mover
- Type of coupled machine
- Power absorbed by coupled machine
- Hours/day duty & start/stop frequency
- Both coupled shaft diameters
- Distance between shaft ends
- Likely machine alignment quality
angular, parallel and axial

DRIVE COUPLINGS	Page
Fenaflex Couplings	110
Fenaflex Power Ratings	111
Fenaflex Dimensions	112
Fenaflex Spacer Couplings	113
Fenaflex Flywheel Couplings	114
HRC Couplings	116
HRC Dimensions	117
Jaw Couplings	118
Rigid Couplings	120
Installation	121

The Fenaflex coupling is a highly flexible, torsionally elastic coupling offering versatility to designers and engineers with a choice of flange combinations to suit most applications.

Tyre coupling flanges are available in either F or H Taper Lock™ fitting or pilot bored, which can be finish bored to the required size.

With the addition of a spacer assembly the coupling can be used to accommodate standard distances between shaft ends, (DBSE) facilitating centrifugal pump maintenance.

Fenaflex couplings can accommodate simultaneous maximum misalignment in all planes without imposing undue loads on adjacent bearings and the excellent shock-absorbing properties of the flexible tyre reduce vibration and torsional oscillations.

Fenaflex tyres are available in natural rubber compounds for use in ambient temperatures between -50°C and $+50^{\circ}\text{C}$. Chloroprene rubber compounds are available for use in adverse operating conditions (e.g. oil or grease contamination) and can be used in temperatures of -15°C to $+70^{\circ}\text{C}$. The chloroprene compound should also be used when fire-resistance and anti-static (FRAS) properties are required, and it is this tyre material that is used with specific flange modifications in the ATEX  approved variant.

SELECTION

(a) Service Factor

Determine the required Service Factor from table below.

(b) Design Power

Multiply the normal running power by the service factor. This gives the design power which is used as a basis for selecting the coupling.

(c) Coupling Size

Refer to Power Ratings table (page 111) and from the appropriate speed read across until a power greater than that required in step (b) is found.

The size of Fenaflex coupling required is given at the head of that column.

(d) Bore Size

Check from Dimensions table (page 112) that chosen flanges can accommodate required bores.

EXAMPLE

A Fenaflex coupling is required to transmit 45kW from an A.C. electric motor which runs at 1440 rev/min to a rotary screen for 12 hours per day. The motor shaft is 60mm diameter and the screen shaft is 55mm diameter. Taper Lock is required.

(a) Service Factor

The appropriate service factor is 1.4.

(b) Design Power

Design power = $45 \times 1.4 = 63\text{kW}$.

(c) Coupling Size

By reading across from 1440 rev/min in the power ratings table the first power figure to exceed the required 63kW in step (b) is 75,4kW. The size of coupling is F90 Fenaflex.

(d) Bore Size

By referring to the dimensions table it can be seen that both shaft diameters fall within the bore range available.

SERVICE FACTORS

SPECIAL CASES For applications where substantial shock, vibration and torque fluctuations occur, and for reciprocating machines (e.g. internal combustion engines, piston pumps and compressors) refer to your local Authorised Distributor with full machine details for analysis.	Type of Driving Unit					
	Electric Motors Steam Turbines			Internal Combustion Engines† Steam Engines Water Turbines		
	Hours per day duty			Hours per day duty		
Type of Driven Machine	10 and under	over 10 to 16 incl.	over 16	10 and under	over 10 to 16 incl.	over 16
CLASS 1 Agitators, Brewing machinery, Centrifugal compressors and pumps. Belt conveyors, Dynamometers, Lineshafts, Fans up to 7.5kW. Blowers and exhausters (except positive displacement), Generators.	0.8	0.9	1.0	1.3	1.4	1.5
CLASS 2* Clay working machinery, General machine tools, paper mill beaters and winders, Rotary pumps, Rubber extruders, Rotary screens, Textile machinery, Marine propellers and Fans over 7.5kw.	1.3	1.4	1.5	1.8	1.9	2.0
CLASS 3* Bucket elevators, Cooling tower fans, Piston compressors and pumps, Foundry machinery, Metal presses, Paper mill calenders, Hammer mills, Presses and pulp grinders, Rubber calenders, Pulverisers and Positive displacement blowers.	1.8	1.9	2.0	2.3	2.4	2.5
CLASS 4* Reciprocating conveyors, Gyrotory crushers, Mills (ball, pebble and rod), Rubber machinery (Banbury mixers and mills) and Vibratory screens.	2.3	2.4	2.5	2.8	2.9	3.0

* It is recommended that keys (with top clearance if in Taper Lock bushes) are fitted on applications where load fluctuation is expected.

† Couplings for use with internal combustion engines may require special consideration, refer to pages 114.

Fenaflex® Couplings - Power Ratings



POWER RATINGS (KW)

Speed rev/min	Coupling Size														
	F40	F50	F60	F70	F80	F90	F100	F110	F120	F140	F160	F180	F200	F220	F250
100	0.25	0.69	1.33	2.62	3.93	5.24	7.07	9.16	13.9	24.3	39.5	65.7	97.6	121.0	154.0
200	0.50	1.38	2.66	5.24	7.85	10.50	14.10	18.30	27.9	48.7	79.0	131.0	195.0	243.0	307.0
300	0.75	2.07	3.99	7.85	11.80	15.70	21.20	27.50	41.8	73.0	118.0	197.0	293.0	364.0	461.0
400	1.01	2.76	5.32	10.50	15.70	20.90	28.30	36.60	55.7	97.4	158.0	263.0	391.0	486.0	615.0
500	1.26	3.46	6.65	13.10	19.60	26.20	35.30	45.80	69.6	122.0	197.0	328.0	488.0	607.0	768.0
600	1.51	4.15	7.98	15.70	23.60	31.40	42.40	55.00	83.6	146.0	237.0	394.0	586.0	729.0	922.0
700	1.76	4.84	9.31	18.30	27.50	36.60	49.50	64.10	97.5	170.0	276.0	460.0	684.0	850.0	1076.0
720	1.81	4.98	9.57	18.80	28.30	37.70	50.90	66.00	100.0	175.0	284.0	473.0	703.0	875.0	1106.0
800	2.01	5.53	10.60	20.90	31.40	41.90	56.50	73.30	111.0	195.0	316.0	525.0	781.0	972.0	1229.0
900	2.26	6.22	12.00	23.60	35.30	47.10	63.60	82.50	125.0	219.0	355.0	591.0	879.0	1093.0	1383.0
960	2.41	6.63	12.80	25.10	37.70	50.30	67.90	88.00	134.0	234.0	379.0	630.0	937.0	1166.0	1475.0
1000	2.51	6.91	13.30	26.20	39.30	52.40	70.70	91.60	139.0	243.0	395.0	657.0	976.0	1215.0	1537.0
1200	3.02	8.29	16.00	31.40	47.10	62.80	84.80	110.00	167.0	292.0	474.0	788.0	1172.0		
1400	3.52	9.68	18.60	36.60	55.00	73.30	99.00	128.00	195.0	341.0	553.0	919.0			
1440	3.62	9.95	19.10	37.70	56.50	75.40	102.00	132.00	201.0	351.0	568.0	945.0			
1600	4.02	11.10	21.30	41.90	62.80	83.80	113.00	147.00	223.0	390.0	632.0				
1800	4.52	12.40	23.90	47.10	70.70	94.20	127.00	165.00	251.0	438.0					
2000	5.03	13.80	26.60	52.40	78.50	105.50	141.00	183.00	279.0						
2200	5.53	15.20	29.30	57.60	86.40	115.00	155.00	202.00							
2400	6.03	16.60	31.90	62.80	94.20	126.00	170.00								
2600	6.53	18.00	34.60	68.10	102.00	136.00	184.00								
2800	7.04	19.40	37.20	73.30	110.00	147.00									
2880	7.24	19.90	38.30	75.40	113.00	151.00									
3000	7.54	20.70	39.90	78.50	118.00	157.00									
3600	9.05	24.90	47.90	94.20											

The figures in heavier type are for standard motor speeds. All these power ratings are calculated at constant torque. For speeds below 100 rev/min and intermediate speeds use nominal torque ratings.

PHYSICAL CHARACTERISTICS – FLEXIBLE TYRES

Characteristics	Coupling Size														
	F40	F50	F60	F70	F80	F90	F100	F110	F120	F140	F160	F180	F200	F220	F250
Maximum speed rev/min	4,500	4,500	4,000	3,600	3,100	3,000	2,600	2,300	2,050	1,800	1,600	1,500	1,300	1,100	1,000
Nominal Torque Nm T _{KN}	24	66	127	250	375	500	675	875	1,330	2,325	3,770	6,270	9,325	11,600	14,675
Maximum Torque Nm T _{KN MAX}	64	160	318	487	759	1,096	1,517	2,137	3,547	5,642	9,339	16,455	23,508	33,125	42,740
Torsional Stiffness Nm/°	5	13	26	41	63	91	126	178	296	470	778	1,371	1,959	2,760	3,562
Max. parallel misalignment mm	1.1	1.3	1.6	1.9	2.1	2.4	2.6	2.9	3.2	3.7	4.2	4.8	5.3	5.8	6.6
Maximum end float mm ±	1.3	1.7	2.0	2.3	2.6	3.0	3.3	3.7	4.0	4.6	5.3	6.0	6.6	7.3	8.2
Approximate mass. kg	0.1	0.3	0.5	0.7	1.0	1.1	1.1	1.4	2.3	2.6	3.4	7.7	8.0	10.0	15.0
Alternating Torque ± Nm @ 10Hz T _{KW}	11	26	53	81	127	183	252	356	591	940	1,556	2,742	3,918	5,521	7,124
Resonance Factor V _R	7	7	7	7	7	7	7	7	7	7	7	7	7	7	7
Damping Coefficient Ψ	0.9	0.9	0.9	0.9	0.9	0.9	0.9	0.9	0.9	0.9	0.9	0.9	0.9	0.9	0.9

Maximum torque figures should be regarded as short duration overload ratings for use in such circumstances as direct-on-line motor starting.

All Fenaflex tyre couplings have an angular misalignment capacity up to 4°.

FLEXIBLE TYRE CODE NUMBERS

Unless otherwise specified Fenaflex flexible tyres will be supplied in a natural rubber compound which is suitable for operation in temperatures -50°C to +50°C. A chloroprene compound is available which is Fire Resistant and Anti-Static (FRAS) and has greater resistance to heat and oil.

This is suitable for operation in temperatures -15°C to +70°C. For temperatures outside these ranges – consult your local Authorised Distributor.

The FRAS tyre variant is used with specifically modified metal flanges to create the ATEX approved variant.

Size	Natural	FRAS	Coupling Size	M Dimension (mm)	Gap Between Tyre Ends (mm)	Clamping Screw Torque (Nm)	Screw Size
F40	033A0048	033A0068					
F50	033B0048	033B0068	F40*	22	2	15	M6
F60	033C0048	033C0068	F50*	25	2	15	M6
F70	033D0048	033D0068	F60*	33	2	15	M6
F80	033E0048	033E0068	F70	23	3	24	M8
F90	033F0048	033F0068	F80	25	3	24	M8
F100	033G0048	033G0068	F90	27	3	40	M10
F110	033H0048	033H0068	F100	27	3	40	M10
F120	033J0048	033J0068	F110	25	3	40	M10
F140	033K0048	033K0068	F120	29	3	50	M12
F160	033L0048	033L0068	F140	32	5	55	M12
F180	033Q0048	033Q0068	F160	30	5	80	M16
F200	033M0048	033M0068	F180	46	6	105	M16
F220	033N0048	033N0068	F200	48	6	120	M16
F250	033P0048	033P0068	F220	55	6	165	M20
			F250	59	6	165	M20

*Hexagonal socket caphead clamping screws on these sizes.

FLANGES

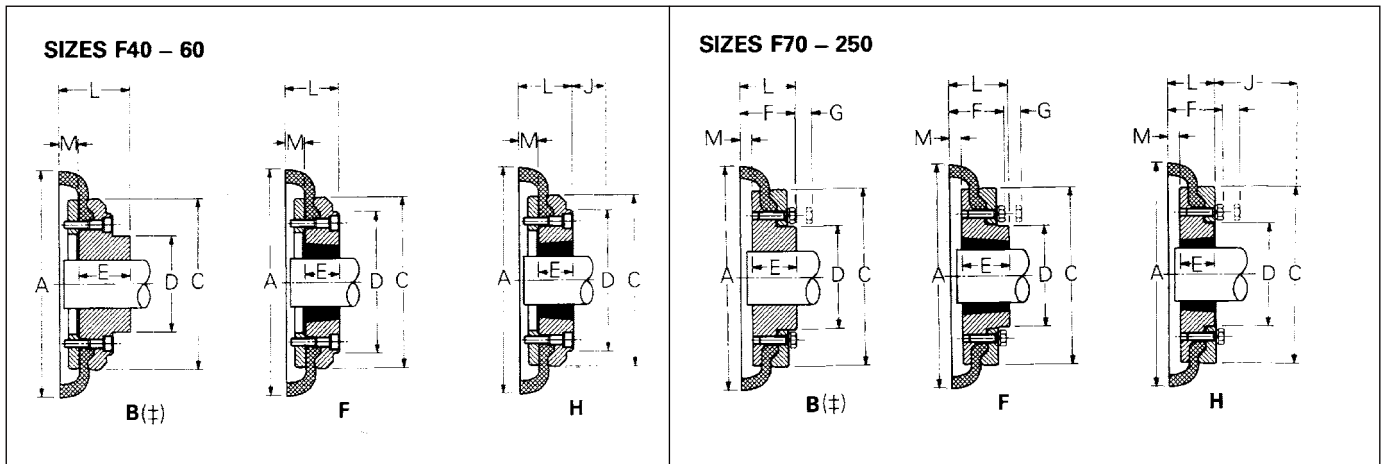

DIMENSIONS OF FENAFLEX FLANGES TYPES B, F & H

Catalogue # Code	Size	Type	Bush No. #	Max Bore		Types F & H			Type B		Screw over Key	A	C	D	F	G§	M¶	Mass* (kg)	Inertia* (kgm²)
				Metric	Inch	L	E	J†	L	E									
033A0501	F40	B	—	32	—	—	—	29	33.0	22	M5	104	82	—	—	—	11.0	0.8	0.00074
033A0502	F40	F	1008	25	1"	33.0	22	29	—	—	—	104	82	—	—	—	11.0	0.8	0.00074
033A0503	F40	H	1008	25	1"	33.0	22	29	—	—	—	104	82	—	—	—	11.0	0.8	0.00074
033B0501	F50	B	—	38	—	—	—	38	45.0	32	M5	133	100	79	—	—	12.5	1.2	0.00115
033B0502	F50	F	1210	32	1 1/4"	38.0	25	38	—	—	—	133	100	79	—	—	12.5	1.2	0.00115
033B0503	F50	H	1210	32	1 1/4"	38.0	25	38	—	—	—	133	100	79	—	—	12.5	1.2	0.00115
033C0501	F60	B	—	45	—	—	—	38	55.0	38	M6	165	125	70	—	—	16.5	2.0	0.0052
033C0502	F60	F	1610	42	1 5/8"	42.0	25	38	—	—	—	165	125	103	—	—	16.5	2.0	0.0052
033C0503	F60	H	1610	42	1 5/8"	42.0	25	38	—	—	—	165	125	103	—	—	16.5	2.0	0.0052
033D0301	F70	B	—	50	—	—	—	—	47.0	35	M10	187	144	80	50	13	11.5	3.1	0.009
033D0302	F70	F	2012	50	2"	44.0	32	42	—	—	—	187	144	80	50	13	11.5	3.1	0.009
033D0303	F70	H	1610	42	1 5/8"	42.0	25	38	—	—	—	187	144	80	50	13	11.5	3.0	0.009
033E0301	F80	B	—	60	—	—	—	—	55.0	42	M10	211	167	98	54	16	12.5	4.9	0.018
033E0302	F80	F	2517	60	2 1/2"	58.0	45	48	—	—	—	211	167	97	54	16	12.5	4.9	0.018
033E0303	F80	H	2012	50	2"	45.0	32	42	—	—	—	211	167	98	54	16	12.5	4.6	0.017
033F0301	F90	B	—	70	—	—	—	—	63.5	49	M12	235	188	112	60	16	13.5	7.1	0.032
033F0302	F90	F	2517	60	2 1/2"	59.5	45	48	—	—	—	235	188	108	60	16	13.5	7.0	0.031
033F0303	F90	H	2517	60	2 1/2"	59.5	45	48	—	—	—	235	188	108	60	16	13.5	7.0	0.031
033G0301	F100	B	—	80	—	—	—	—	70.5	56	M12	254	216	125	62	16	13.5	9.9	0.055
033G0302	F100	F	3020	75	3"	65.5	51	55	—	—	—	254	216	120	62	16	13.5	9.9	0.055
033G0303	F100	H	2517	60	2 1/2"	59.5	45	48	—	—	—	254	216	113	62	16	13.5	9.4	0.054
033H0301	F110	B	—	90	—	—	—	—	75.5	63	M12	279	233	128	62	16	12.5	12.5	0.081
033H0302	F110	F	3020	75	3"	63.5	51	55	—	—	—	279	233	134	62	16	12.5	11.7	0.078
033H0303	F110	H	3020	75	3"	63.5	51	55	—	—	—	279	233	134	62	16	12.5	11.7	0.078
033J0301	F120	B	—	100	—	—	—	—	84.5	70	M16	314	264	143	67	16	14.5	16.9	0.137
033J0302	F120	F	3525	100	4"	79.5	65	67	—	—	—	314	264	140	67	16	14.5	16.5	0.137
033J0303	F120	H	3020	75	3"	65.5	51	55	—	—	—	314	264	140	67	16	14.5	15.9	0.130
033K0301	F140	B	—	130	—	—	—	—	110.5	94	M20	359	311	178	73	17	16.0	22.2	0.254
033K0302	F140	F	3525	100	4"	81.5	65	67	—	—	—	359	311	178	73	17	16.0	22.3	0.255
033K0303	F140	H	3525	100	4"	81.5	65	67	—	—	—	359	311	178	73	17	16.0	22.3	0.255
033L0301	F160	B	—	140	—	—	—	—	117	102	M20	402	345	187	78	19	15.0	35.8	0.469
033L0302	F160	F	4030	115	4 1/2"	92.0	77	80	—	—	—	402	345	197	78	19	15.0	32.5	0.380
033L0303	F160	H	4030	115	4 1/2"	92.0	77	80	—	—	—	402	345	197	78	19	15.0	32.5	0.380
033Q0301	F180	B	—	150	—	—	—	—	137	114	M20	470	398	200	94	19	23.0	49.1	0.871
033Q0302	F180	F	4535	125	5"	112.0	89	89	—	—	—	470	398	205	94	19	23.0	42.2	0.847
033Q0303	F180	H	4535	125	5"	112.0	89	89	—	—	—	470	398	205	94	19	23.0	42.2	0.847
033M0301	F200	B	—	150	—	—	—	—	138	114	M20	508	429	200	103	19	24.0	58.2	1.301
033M0302	F200	F	4535	125	5"	113.0	89	89	—	—	—	508	429	205	103	19	24.0	53.6	1.281
033M0303	F200	H	4535	125	5"	113.0	89	89	—	—	—	508	429	205	103	19	24.0	53.6	1.281
033N0301	F220	B	—	160	—	—	—	—	154.5	127	M20	562	474	218	118	20	27.5	79.6	2.142
033N0302	F220	F	5040	125	5"	129.5	102	92	—	—	—	562	474	223	118	20	27.5	72.0	2.104
033N0303	F220	H	5040	125	5"	129.5	102	92	—	—	—	562	474	223	118	20	27.5	72.0	2.104
033P0301	F250	B	—	190	—	—	—	—	161.5	132	M20	628	532	254	125	25	29.5	104.0	3.505

Dimensions in millimetres unless otherwise stated.

§ G is the amount by which clamping screws need to be withdrawn to release tyre.

† J is the wrench clearance to allow for tightening/loosening the bush on the shaft and the clamp ring screws on sizes F40, F50 and F60. The use of a shortened wrench will allow this dimension to be reduced.

¶ M is half the distance between flanges. Shaft ends, although normally located twice M apart, can project beyond the flanges as shown. In this event allow sufficient space between shaft ends for end float and misalignment.

* Mass and inertia figures are for single flange with mid range bore and include clamping ring, screws and washers and half tyre.

‡ For pilot bore 'B' flange code as listed. Flanges are also available finish bored with keyway if required. Bore must be specified on order.

Note: On sizes F70, 80, 100 and 120 the 'F' direction bush is larger than that in the 'H' direction.

Note: Flange assemblies comprise hub, clamp ring and clamp ring screws/washers.

Fenaflex® Spacer Couplings



Fenaflex spacer couplings consist of a Fenaflex tyre coupling (size F40–F140) plus a spacer flange assembly.

They are designed for use on applications where it is an advantage to be able to move either shaft axially without disturbing the driving or driven machine (e.g. centrifugal pump rotors), Fenaflex spacer couplings are primarily designed for standard distance between shaft end dimensions of 80, 100, 140 and 180mm.

SELECTION

1. Select a suitable size of Fenaflex coupling using the method shown on page 110. Read down the first column in table below and locate the size of coupling selected.
2. Read across until the required distance between shaft ends can be accommodated.
3. Note the required spacer coupling designation at head of column.

4. Check from the Spacer Coupling Dimensions table below that the selected spacer/coupling combination can accommodate the machine shaft size.

Note

A full specification comprises:

- 1 x Spacer assembly
- 3 x Taper Lock bushes
- 2 x Fenaflex flanges
- 1 x Fenaflex tyre

DISTANCE BETWEEN SHAFT ENDS

Size	Distance between Shaft Ends (mm)																			
	SM12		SM16				SM25						SM30				SM35			
	80 (100)		100		140		100		140		180		140		180		140		180	
	Min	Max	Min	Max	Min	Max	Min	Max	Min	Max	Min	Max	Min	Max	Min	Max	Min	Max	Min	Max
F40	80	100	100	113	140	150														
F50			100	116	140	156														
F60			100	124	140	164														
F70							100	114	140	154	180	194								
F80							100	117	140	157	180	197								
F90									140	158	180	198								
F100													140	158	180	198				
F110													140	156	180	196				
F120																	140	160	180	200
F140																	140	163	180	203

Note: Alternative distances between shaft ends may be accommodated. Consult your local Authorised Distributor.

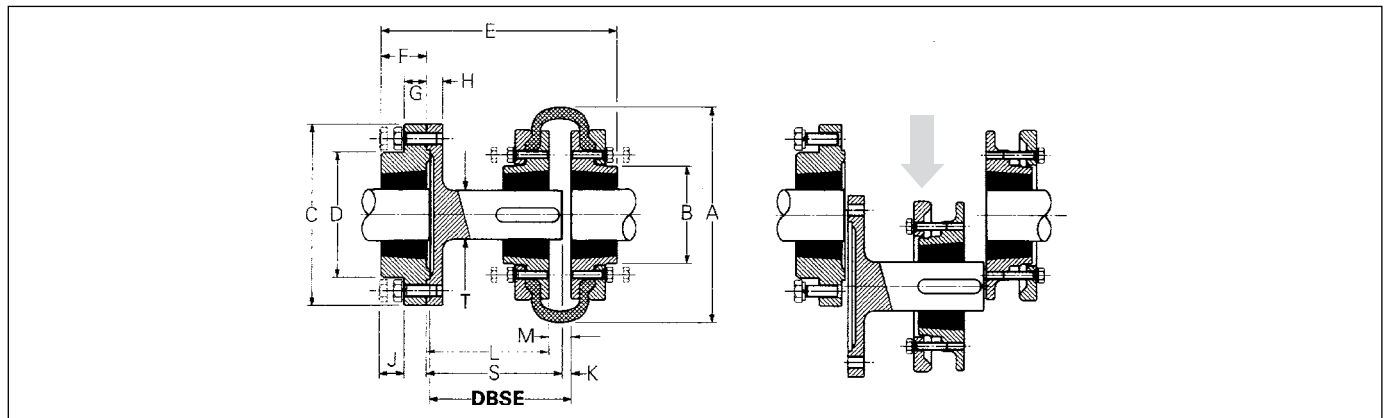

SPACER COUPLING DIMENSIONS

Spacer	Nom DBSE	Fenaflex	Spacer Code	Spacer Bush Size	Max. Bore		Fenaflex Bush Size		A	B	C	D	E	F	G	H	J	K	L	M	S	T	
					mm	Inch	mm	Inch															
SM12	80	F40	033S1200	1210	32	1 1/4"	1008	25	1"	104	82	118	83	134	25	14	15	14	6	65	22	77	25
SM12	100	F40	033S1200	1210	32	1 1/4"	1008	25	1"	104	82	118	83	140	25	14	15	14	22	77	22	77	25
SM16	100	F40*	033T1600	1610	42	1 1/8"	1008	25	1"	104	82	127	80	157	25	18	15	14	9	88	22	94	32
SM16	140	F40*	033V1600	1610	42	1 1/8"	1008	25	1"	104	82	127	80	187	25	18	15	14	9	128	22	134	32
SM16	100	F50	033V1600	1610	42	1 5/8"	1210	32	1 1/4"	133	79	127	80	160	25	18	15	14	9	85	25	94	32
SM16	140	F50	033V1600	1610	42	1 5/8"	1210	32	1 1/4"	133	79	127	80	200	25	18	15	14	9	125	25	134	32
SM16	100	F60	033T1600	1610	42	1 5/8"	1610	42	1 5/8"	165	70	127	80	161	25	18	15	14	9	78	33	94	32
SM16	140	F60	033V1600	1610	42	1 5/8"	1610	42	1 5/8"	165	70	127	80	201	25	18	15	14	9	118	33	134	32
SM25	100	F70†	033T2500	2517	60	2 1/2"	2012	50	2"	187	80	178	123	180	45	22	16	14	9	80	23	94	48
SM25	140	F70†	033V2500	2517	60	2 1/2"	2012	50	2"	187	80	178	123	220	45	22	16	14	9	120	23	134	48
SM25	180	F70†	033W2500	2517	60	2 1/2"	2012	50	2"	187	80	178	123	260	45	22	16	14	9	160	23	174	48
SM25	100	F80	033T2500	2517	60	2 1/2"	2517	60	2 1/2"	211	95	178	123	193	45	22	16	14	9	78	25	94	48
SM25	140	F80	033V2500	2517	60	2 1/2"	2517	60	2 1/2"	211	95	178	123	233	45	22	16	14	9	118	25	134	48
SM25	180	F80	033W2500	2517	60	2 1/2"	2517	60	2 1/2"	211	95	178	123	273	45	22	16	14	9	158	25	174	48
SM25	140	F90	033V2500	2517	60	2 1/2"	2517	60	2 1/2"	235	108	178	123	233	45	22	16	14	9	116	27	134	48
SM25	180	F90	033W2500	2517	60	2 1/2"	2517	60	2 1/2"	235	108	178	123	273	45	22	16	14	9	156	27	174	48
SM30	140	F100	033V3000	3020	75	3"	3020	75	3"	254	120	216	146	245	51	29	20	17	9	116	27	134	60
SM30	180	F100	033W3000	3020	75	3"	3020	75	3"	254	120	216	146	285	51	29	20	17	9	156	27	174	60
SM30	140	F110	033V3000	3020	75	3"	3020	75	3"	279	134	216	146	245	51	29	20	17	9	118	25	134	60
SM30	180	F110	033W3000	3020	75	3"	3020	75	3"	279	134	216	146	285	51	29	20	17	9	158	25	174	60
SM35	140	F120†	033V3500	3525	100	4"	3525	100	4"	314	140	248	178	272	63	34	20	17	9	114	29	134	80
SM35	180	F120†	033W3500	3525	100	4"	3525	100	4"	314	140	248	178	312	63	34	20	17	9	154	29	174	80
SM35	140	F140	033V3500	3525	100	4"	3525	100	4"	359	178	248	178	271	63	34	20	17	9	111	32	134	80
SM35	180	F140	033W3500	3525	100	4"	3525	100	4"	359	178	248	178	312	63	34	20	17	9	151	32	174	80

Note: Larger sizes of spacer coupling can be manufactured to order. Consult your local Authorised Distributor.

* F40 'B' Flange must be used to fit spacer shaft.

† 'F' Flange must be used to fit spacer shaft.

Designed to fit standard SAE and other popular flywheel configurations, these couplings use chloroprene flexible elements and employ standard B, F or H type driven flanges.

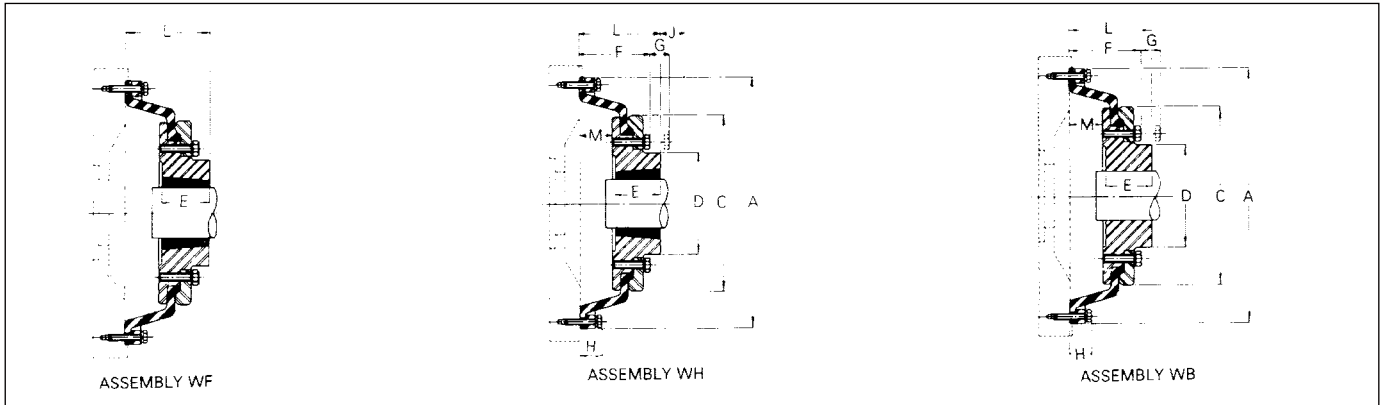

DIMENSIONS

Driving Flange — W (Bolt ring)									Driven Flanges — Through Bore and Taper Lock — F & H																				
Code No.	Size	PCD	Bolt†		A	H	Mass (kg)	Inertia (kg m ²)	Code No.	Size	Type	Bush	Max Bore	C	D	E	F	G	J††	L	M	Screw Over Key	Mass (kg)	Inertia (kg m ²)					
			Flywheel Fixing Screws*																										
033D0010	87	8.750"	8 off M8 x 30 lg		240	26	1.41	0.016	033D0301	F70	B	—	50	144	80	35	73	13	—	70	35	M10	3.1	0.009					
			8 off 5/16" UNC x 1 1/8" lg						033D0302	F70	F	2012	50	144	80	32	73	13	42	67	35	—	—	—	—	—	—	3.1	0.009
									033D0303	F70	H	1610	42	144	80	30	73	13	38	65	35	—	—	—	—	—	—	—	3.0
033E0010	96	9.625"	8 off M10 x 35 lg		262	30	1.87	0.025	033E0301	F80	B	—	60	167	97	42	81	16	—	82	40	M10	4.9	0.018					
			8 off 3/8" UNC x 1 3/8" lg						033E0302	F80	F	2517	60	167	95	45	81	16	48	85	40	—	—	—	—	—	—	4.9	0.018
									033E0303	F80	H	2012	50	167	95	32	81	16	42	72	40	—	—	—	—	—	—	4.6	0.017
033R0010	112	11.250"	8 off 7/16" UNF x 1 1/2" lg		305	32	2.49	0.048	033G0301	F100	B	—	80	216	125	48	89	16	—	86	41	M12	9.9	0.055					
									033G0302	F100	F	3020	75	216	120	51	89	16	55	89	41	—	—	—	—	—	7.0	0.031	
									033G0303	F100	H	2517	60	216	113	45	89	16	48	83	41	—	—	—	—	—	—	7.0	0.031
033G0010	116	11.625"	8 off M10 x 35 lg		313	30	2.51	0.051	033G0301	F100	B	—	80	216	125	48	89	16	—	89	41	M12	9.9	0.055					
			8 off 3/8" UNC x 1 3/8" lg						033G0302	F100	F	3020	75	216	120	51	89	16	55	92	41	—	—	—	—	—	9.9	0.055	
			8 off 3/8" BSF x 1 3/8" lg						033G0303	F100	H	2517	60	216	113	45	89	16	48	86	41	—	—	—	—	—	—	9.4	0.054
033H0010	131	13.125"	8 off M10 x 45 lg		351	39	3.71	0.094	033H0301	F110	B	—	90	233	128	63	102	16	—	118	55	M12	12.5	0.081					
			8 off 3/8" UNC x 1 3/4" lg						033H0302	F110	F	3020	75	233	134	51	102	16	55	106	55	—	—	—	—	—	11.7	0.078	
									033H0303	F110	H	3020	75	233	134	51	102	16	55	106	55	—	—	—	—	—	—	11.7	0.078
033S0010	135	13.500"	6 off 3/8" UNC x 1 3/4" lg		364	37	4.16	0.113	033H0301	F110	B	—	90	233	128	63	102	16	—	120	57	M12	12.5	0.081					
									033H0302	F110	F	3020	75	233	134	51	106	16	55	108	57	—	—	—	—	—	11.7	0.078	
									033H0303	F110	H	3020	75	233	134	51	106	16	55	108	57	—	—	—	—	—	—	11.7	0.078
033K0010	172	17.250"	8 off M12 x 50 lg		465	41	7.10	0.320	033K0301	F140	B	—	130	311	178	94	121	17	—	162	68	M20	22.2	0.254					
			8 off 1/2" UNC x 2" lg						033K0302	F140	F	3525	100	311	178	65	121	17	67	133	68	—	—	—	—	—	22.3	0.255	
									033K0303	F140	H	3525	100	311	178	65	121	17	67	133	68	—	—	—	—	—	—	22.3	0.255

All dimensions in millimetres unless otherwise stated.
 Driving flange mass & inertia given are for the bolt ring, bolts and half of the element.
 Driven flange mass & inertia given are for an assembled flange having a mid range bore or bush and half the element.
 †† J is the wrench clearance to allow for tightening/loosening the bush. A shortened wrench will allow this dimension to be reduced.
 * Flywheel fixing screws are not a stock component but should be sourced to the above dimensions, according to thread type used in the flywheel concerned. They should be used with rectangular / square section split washers, respectively.

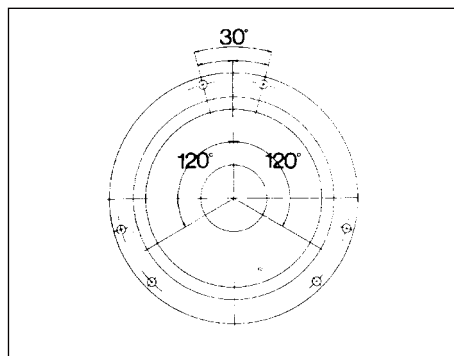

†W FLANGE—
 bolt holes are equi-spaced except size 135W shown

Replacement elements for previously catalogued sizes 192, 213 and 252 are available – Consult your local Authorised Distributor.

FENAFLEX HIGH SPEED COUPLINGS

Fenaflex flywheel style elements can be deployed to couple a balanced disc with Taper Lock weld-on-hub shaft fixing (effectively replacing the flywheel in the designs illustrated above) to a standard Fenaflex flange, for use at higher rotational speeds.

Consult your local Authorised Distributor for details.



FENAFLEX ELEMENTS—PHYSICAL CHARACTERISTICS AND POWER RATINGS

Coupling Size	Element Part No.	Normal Torque (Nm) T_{KN}	Maximum Torque (Nm) T_{KMAX}	Maximum Alternating Torque (Nm) $\pm T_{KW}$	Resonance Factor V_R	Damping Energy Ratio ψ	Dynamic Stiffness (Nm/rad) C_{Tdyn}	Power at * 1500 rev/min (kW)	Power at * 1800 rev/min (kW)
87 (SAE 7½)	033D0100	239	717	155	7.0	0.9	6847	37	45
	033D0101	478	956	238	7.0	0.9	13695	75	90
	033D0102	239	717	120	7.0	0.9	3427	37	45
	033D0105	239	717	64	7.0	0.9	1369	37	45
96 (SAE 8)	033E0100	325	975	211	7.0	0.9	9311	51	61
	033E0101	650	1300	324	7.0	0.9	18623	102	122
	033E0102	325	975	163	7.0	0.9	4653	51	61
	033E0105	325	975	87	7.0	0.9	1862	51	61
112	033R0100	592	1776	385	7.0	0.9	16959	93	111
	033R0101	1184	2368	590	7.0	0.9	33922	186	223
	033R0105	592	1776	158	7.0	0.9	3392	93	111
116 (SAE 10)	033G0100	592	1776	385	7.0	0.9	16961	93	111
	033G0101	1184	2368	590	7.0	0.9	33922	186	223
	033G0102	592	1776	296	7.0	0.9	8480	93	111
	033G0105	592	1776	158	7.0	0.9	3392	93	111
131 (SAE 11½)	033H0100	754	2262	490	7.0	0.9	21602	118	142
	033H0101	1508	3016	751	7.0	0.9	43204	237	284
	033H0102	754	2262	377	7.0	0.9	10801	118	142
	033H0105	754	2262	201	7.0	0.9	4320	118	142
135	033S0101	1508	3016	751	7.0	0.9	43204	237	284
	033S0105	754	2262	201	7.0	0.9	4320	118	142
172 (SAE 14)	033K0100	1919	5757	1247	7.0	0.9	54979	301	362
	033K0101	3838	7676	1912	7.0	0.9	109959	602	723
	033K0102	1919	5757	960	7.0	0.9	27492	301	362
	033K0105	1919	5757	511	7.0	0.9	10996	301	362

Selection of Fenaflex flywheel couplings should take account of design power (using Service Factors on page 110) and speed, and also the torsional characteristics of the coupled machines – consult your local Authorised Distributor.

* Power ratings at other speeds directly proportional to these values.

ALL FENAFLEX COUPLINGS – ORDERING INSTRUCTIONS

SHAFT TO SHAFT COUPLING USING FLEXIBLE TYRE.

Consists of:

2–Flanges (page 112)

T/L bushes for F and H flanges only (pages 126 & 127)

1–Flexible tyre (page 111)

EXAMPLE ORDER

Fenaflex coupling F90BH comprising:

1–F90B flange bored 70mm (coded at time of order).

1–F90H flange code 033F0303

1–2517 T/L bush (bore 35mm) code 029M0035

1–F90 Flexible tyre (Natural) code 033F0048

FENAFLEX SPACER COUPLING

Consists of a standard Fenaflex coupling (using B, F or H flanges as desired) together with a spacer flange and a third Taper Lock bush.

EXAMPLE ORDER

Fenaflex spacer assembly F110FF–SM30/140 comprising:

2–F110F flanges – 033H0302 (page 112)

1–F110 flexible tyre – 033H0048 (page 111)

1–SM30 x 140mm spacer flange – 033V3000 (page 112)

1–3020 T/L bush to suit motor shaft – 029P00– (page 126-127)

1–3020 x 60mm T/L bush (dimension 'T' page 126) – 029P0060 (page 127)

1–3030 T/L bush to suit driven shaft – 029Q00– (page 127)

FENAFLEX FLYWHEEL COUPLING

Consists of:

1–Driving (W) flange (page 114)

1–Flexible element (above)

1–Driven flange (page 114)

1–T/L bush to suit driven shaft (F & H driven flanges only)

EXAMPLE ORDER

Fenaflex 114 flywheel coupling comprising

1–116W flange 033G0010

1–Bolt pack 033X0203

1–Standard element 033G0100

1–F100 F flange 033G0302

1–3020 T/L bush 60mm bore 029P0060

Bolts for flywheel fixing can be supplied but are not a stock component.

These semi-elastic flexible couplings are designed for general purpose use and permit quick and easy assembly by means of Taper Lock bush fixing.

Their characteristics are designed for use particularly on machinery driven from standard IEC electric motors.

Fully machined outside diameters allow alignment by simple straight edge methods.

Shaft connection is "fail safe" due to interacting dog design.

SELECTION

(a) Service Factor

Determine appropriate Service Factor from table below

(b) Design Power

Multiply running power of driven machinery by the service factor. This gives the design power which is used as a basis for coupling selection.

(c) Coupling Size

Refer to Power Ratings table below and read across from the appropriate speed until a power equal to or greater than the design power is found. The size of coupling is given at the head of that column.

(d) Bore Size

From Dimensions table on page 117 check that the required bores can be accommodated.

EXAMPLE

A shaft coupling is required to transmit 70kW between a 1200 rev/min diesel engine and a hoist running over 16hrs/day. Engine shaft is 70mm and the hoist shaft is 75mm.

(a) Service Factor

The appropriate service factor is 2.5.

(b) Design Power

Design power $70 \times 2.5 = 175\text{kW}$.

(c) Coupling Size

Reading across from 1200 rev/min in the speed column of Power Ratings table below, 251kW is the first power to exceed the required 175kW (design power). The size of the coupling at the head of this column is 230.

(d) Bore Size

The Dimensions table (page 117) shows that both shaft diameters are within the bore range available.

SERVICE FACTORS

SPECIAL CASES For applications where substantial shock, vibration and torque fluctuation occur, and for reciprocating machines e.g. internal combustion engines, piston type pumps and compressors, refer to your local Authorised Distributor. with full machine details for torsional analysis.	Type of Driving Unit					
	Electric Motors Steam Turbines			Internal Combustion Engines Steam Engines Water Turbines		
	Hours per day duty			Hours per day duty		
Driven Machine Class	8 and under	over 8 to 16 inclusive	over 16	8 and under	over 8 to 16 inclusive	over 16
UNIFORM Agitators, Brewing machinery, Centrifugal blowers, Centrifugal compressors†, Conveyors, Centrifugal fans and pumps, Generators, Sewage disposal equipment.	1.00	1.12	1.25	1.25	1.40	1.60
MODERATE SHOCK* Clay working machinery, Crane hoists, Laundry machinery, Wood working machinery, Machine tools, Rotary mills, Paper mill machinery, Textile machinery, Non-uniformly loaded centrifugal pumps.	1.60	1.80	2.00	2.00	2.24	2.50
HEAVY SHOCK* Reciprocating conveyors, Crushers, Shakers, Metal mills, Rubber machinery (Banbury mixers and mills), Reciprocating compressors, Welding sets.	2.50	2.80	3.12	3.12	3.55	4.00

* It is recommended that keys (with top clearance if in Taper Lock bushes) are fitted for applications where load fluctuation is expected.

† For Centrifugal Compressors multiply Service Factor by an additional 1, 15.

POWER RATINGS (KW)

Speed rev/min	Coupling Size							
	70	90	110	130	150	180	230	280
100	0.33	0.84	1.68	3.30	6.28	9.95	20.90	33.00
200	0.66	1.68	3.35	6.60	12.60	19.90	41.90	65.00
400	1.32	3.35	6.70	13.20	25.10	39.80	83.80	132.00
600	1.98	5.03	10.10	19.80	37.70	59.70	126.00	198.00
720	2.37	6.03	12.10	23.80	45.20	71.60	151.00	238.00
800	2.64	6.70	13.40	26.40	50.30	79.60	168.00	264.00
960	3.17	8.04	16.10	31.70	60.30	95.50	201.00	317.00
1200	3.96	10.10	20.10	39.60	75.40	119.00	251.00	396.00
1440	4.75	12.10	24.10	47.50	90.50	143.00	302.00	475.00
1600	5.28	13.40	26.80	52.80	101.00	159.00	335.00	528.00
1800	5.94	15.10	30.20	59.40	113.00	179.00	377.00	594.00
2000	6.60	16.80	33.50	66.00	126.00	199.00	419.00	660.00
2200	7.26	18.40	36.90	72.60	138.00	219.00	461.00	726.00
2400	7.92	20.10	40.20	79.20	151.00	239.00	503.00	
2600	8.58	21.80	43.60	85.80	163.00	259.00	545.00	
2880	9.50	24.10	48.30	95.00	181.00	286.00		
3000	9.90	25.10	50.30	99.00	188.00	298.00		
3600	11.90	30.10	60.30	118.00	226.00			
Nominal Torque (Nm)	31.5	80	160	315	600	950	2000	3150
Max Torque (Nm)	72	180	360	720	1500	2350	5000	7200

Fire Resistant/Anti-Static (FRAS) inserts available ex-stock.

For speeds below 100 rev/min, and intermediate speeds, use nominal torque ratings.

* Maximum coupling speeds are calculated using an allowable peripheral speed for the hub material. For selection of smaller sizes with speeds in excess of 3600 rev/min – Consult your local Authorised Distributor.

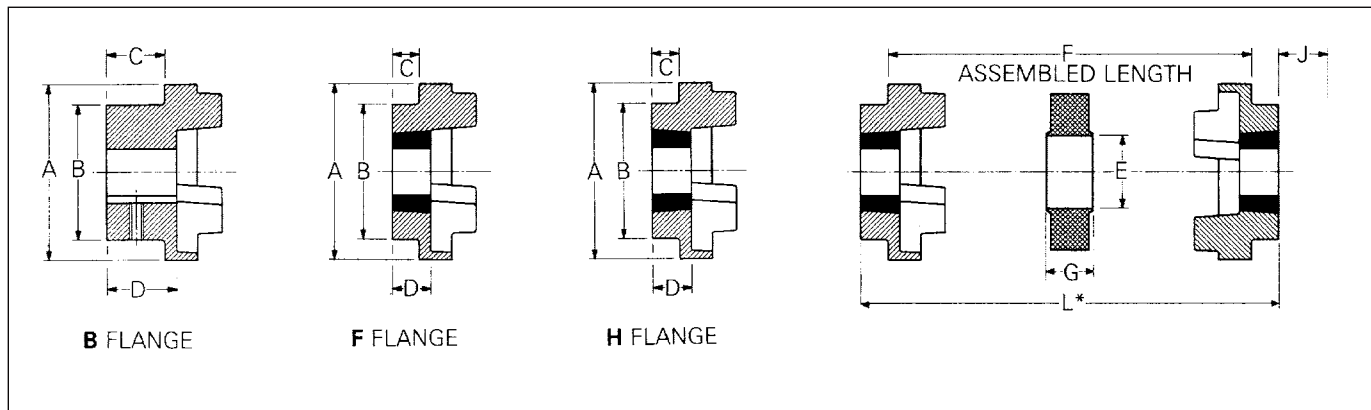

PHYSICAL DIMENSIONS AND CHARACTERISTICS

Size	Common Dimensions					Type F & H						Type B				
	A	B	E	F ₁ ‡	G	Bush size	Max. Bore		C	D	J†	Bore Dia's			C	D
							mm	ins.				Max.	Pilot H9	Screw over key		
70	69	60	31	25.0	18.0	1008	25	1"	20.0	23.5	29	32	8	M 6	20	23.5
90	85	70	32	30.5	22.5	1108	28	1 1/8	19.5	23.5	29	42	10	M 6	26	30.0
110	112	100	45	45.0	29.0	1610	42	1 5/8	18.5	26.5	38	55	10	M10	37	45.0
130	130	105	50	53.0	36.0	1610	42	1 7/8	18.0	26.5	38	60	15	M10	39	47.5
150	150	115	62	60.0	40.0	2012	50	2	23.5	33.5	42	70	20	M10	46	56.0
180	180	125	77	73.0	49.0	2517	60	2 1/2	34.5	46.5	48	80	25	M10	58	70.0
230	225	155	99	85.5	59.5	3020	75	3	39.5	52.5	55	100	25	M12	77	90.0
280	275	206	119	105.5	74.5	3525	100	4	51.0	66.5	67	115	30	M16	90	105.5

† 'J' is the wrench clearance required for tightening/loosening the bush on the shaft. A shortened wrench will allow this dimension to be reduced.

‡ F₁ refers to combinations of flanges: FF, FH, HH, FB, HB, BB.

Bore limits H7 unless otherwise specified.

Size	Assembled Length (L*) Comprising Flange Types			Mass (kg)	Inertia Mr ² (kgm ²)	Dynamic Stiffness (Nm/ ^o)	Maximum Misalignment		Nominal Torque (Nm)
	FF, FH, HH	FB, HB	BB				Parallel	Axial	
90	69.5	76.0	82.5	1.78	0.00115	-	0.3	+0.5	80
110	82.0	100.5	119.0	5.00	0.00400	65	0.3	+0.6	160
130	89.0	110.0	131.0	5.46	0.00780	130	0.4	+0.8	315
150	107.0	129.5	152.0	7.11	0.01810	175	0.4	+0.9	600
180	142.0	165.5	189.0	16.60	0.04340	229	0.4	+1.1	950
230	164.5	202.0	239.5	26.00	0.12068	587	0.5	+1.3	2000
280	207.5	246.5	285.5	50.00	0.44653	1025	0.5	+1.7	3150

All dimensions in millimetres unless otherwise stated.

All HRC couplings have an angular misalignment capacity of up to 1°.

Mass is for an FF, FH or HH coupling with mid range Taper Lock Bushes.

ORDERING CODES

Size	Type F	Type H	Type B Unbored	Standard Element Tempr. -40°C/+100°C	FRAS Element Tempr. -20°C/+80°C
70	045L0002	045L0003	045L0004	045L0009	045L0006
90	045M0002	045M0003	045M0004	045M0009	045M0006
110	045N0012	045N0013	045N0004	045N0009	045N0006
130	045P0002	045P0003	045P0004	045P0009	045P0006
150	045R0002	045R0003	045R0004	045R0009	045R0006
180	045S0002	045S0003	045S0004	045S0009	045S0006
230	045T0002	045T0003	045T0001	045T0009	045T0006
280	045U0002	045U0003	045U0001	045U0009	045U0006

Note: For details of HRC couplings suitable for application to drives involving SAE engine flywheels, consult your local Authorised Distributor.

Type B flanges can be supplied finished bored to H7 tolerance with keyway, if required.

Hub material: GG25 grey cast iron.

Fenner Jaw Couplings offer a range of hub and element variants to meet the demand for low cost, general purpose and spacer type flexible couplings. They cater for incidental misalignment, absorb shock loads and damp out small amplitude vibrations.

HUBS & SPACERS

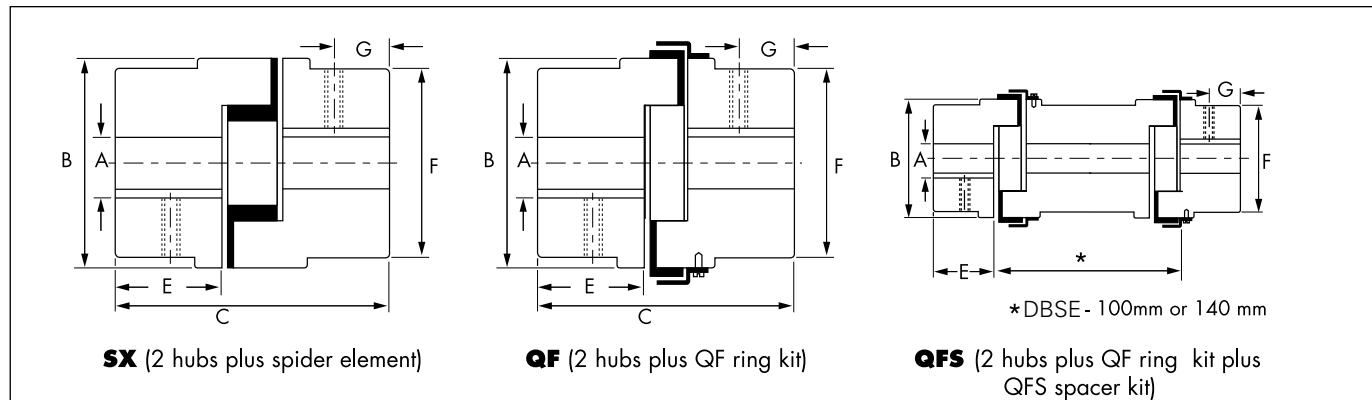

DIMENSIONS: SX, QF AND QFS

Pilot Bore Hub Code*	Size	A		B		C	E	F	G	Set Screw	Approx† mass (kg)	Max. speed (rev/min)
		Pilot	Max	SX	QF							
968G0099	035	3	9	16.0	—	27	13	16.0	3.0	M3	0.03	31000
968A0099	050	6	14	27.5	—	44	16	27.5	6.5	M6	0.10	18000
968B0099	070	9	19	35.0	—	51	19	35.0	9.5	M6	0.25	14000
968C0099	075	9	24	44.5	—	54	21	44.5	8.0	M6	0.45	11000
968H0099	090	9	24	54.0	—	54	21	54.0	8.7	M6	0.55	9000
968D0099	095	9	28	54.0	64	64	25	54.0	11.5	M6	0.65	9000
968E0099	100	12	35	65.0	77	89	35	65.0	12.5	M8	1.55	7000
968F0099	110	15	42	84.0	97	108	43	84.0	20.5	M10	3.00	5000
968J0099	150	15	48	96.0	112	115	45	96.0	22.5	M10	4.85	4000
968K0099	190	19	55	115.0	130	133	54	102.0	22.5	M12	7.00	3600
968L0099	225	19	60	127.0	143	153	64	108.0	25.5	M12	9.00	3600

All dimensions in millimetres unless otherwise stated Hub material is high grade cast iron. Spacer material is aluminium DBSE = distance between shaft ends

† Mass of complete SX or QF type with pilot bore hubs

* Bored or bored and keywayed hubs can be supplied.

ASSEMBLY VARIANTS - SEE DIAGRAM TO RIGHT

- SX** Simple coupling of two close-coupled shafts using 2 x SX hubs + a spider shaped element. The element petals are connected by an inner ring to maintain location between the 'jaws' on the hubs. Urethane and Hytrel® spider elements are available to enhance the coupling power rating. (see page 119).
- QF** On sizes 095 and above, the SX hubs are drilled/tapped for fixing a pressed steel 'ring' or sleeve. The ring retains a QF type nitrile rubber element on which the petals are joined by an outer band. Unscrewing and withdrawing the ring allows the element to be removed for replacement without disturbing the hubs. The retaining ring and element are supplied together as a 'ring kit'.
- QFS** Used when the machine shafts to be coupled are set apart by a DBSE (distance between shaft ends) of 100 or 140mm. This arrangement is common with centrifugal pump applications. A QF coupling is used with a light alloy spacer, which is supplied complete with a second ring kit, to create a spacer coupling which is easily disassembled by removing the two elements.



JAW COUPLING ELEMENTS

Code	Type	Temperature Range (°C)	Max Misalignment		Power Factor
			Ang ^o	Par. (mm)	
968-9000	Nitrile (Spider)	-40 to 100	1	0.38	1
968-9100	Nitrile (QF)	-40 to 100	1	0.38	1
968-9500	Urethane	-35 to 70	1	0.38	1,5
968-9400	Hytrel [®]	-50 to 120	1/2	0.38	3*

4th digit = Alpha character for coupling size

Note: Sizes 90 and 95 SX couplings use the same spider element.

*Power factor = 2 when used with CEC hubs

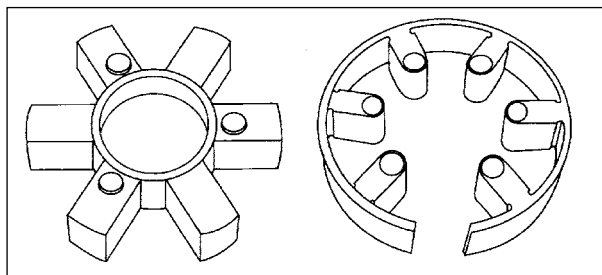

SELECTION

- Find Service Factor for application from table right.
- Multiply normal running power by Service Factor (and Temperature Factor from table above for CEC hubs) to give design power.
- Select a standard nitrile element coupling size from Power Ratings table below by reading across from the appropriate speed until a power equal to or greater than the design power is found. Coupling size is at the head of the column.
- For alternative elements divide the design power from step (b) by the Element Power Factor in table above and repeat step (c) with the new design power.
- For speeds other than those listed use the nominal torque ratings from the Power Ratings table below.

$$\text{Required Torque (Nm)} = \frac{\text{Design power (kW)} \times 9550}{\text{rev/min}}$$

- Check from the hub Dimensions tables that bore capacity is adequate for the coupled shafts.

Note: Orders for complete couplings should include hubs, elements, ring kits and spacer kits separately.

SERVICE FACTORS

Driven Load	Prime Mover
	Electric Motor
Uniform Load	1.0
Moderate Shock	1.5
Heavy Shock	2.0

POWER RATINGS (KW) – NITRILE ELEMENTS

Speed (rev/min)	Coupling Size										
	035	050	070	075	090	095	100	110	150	190	225
100	0.05	0.037	0.06	0.12	0.20	0.27	0.58	1.10	1.56	2.09	2.93
720	0.04	0.260	0.43	0.90	1.44	1.95	4.18	7.94	11.23	15.07	21.09
960	0.05	0.350	0.58	1.20	1.93	2.59	5.58	10.59	14.98	20.09	28.13
1440	0.07	0.530	0.87	1.80	2.89	3.89	8.36	15.88	22.46	30.14	42.20
2880	0.15	1.730	3.61	5.78	7.78	16.73	31.77	44.93	60.28	84.40	84.40
3600	0.19	2.170	4.51	7.22	9.73	20.91	39.71	56.16	75.35	105.50	105.50
Nominal Torque (Nm)	0.50	3.510	5.77	11.90	19.20	25.80	55.4	105.00	150.00	200.00	280.00

SPACERS AND QF RETAINING RINGS – CODES

All codes first 4 digits: 968-

4th digit: Alpha character for coupling size

5/6th digits: Spacer kit = 33; Retaining ring kit = 99

7/8th digits: Retaining ring kit = 00; Spacer kit 100mm = 10; Spacer kit 140mm = 14

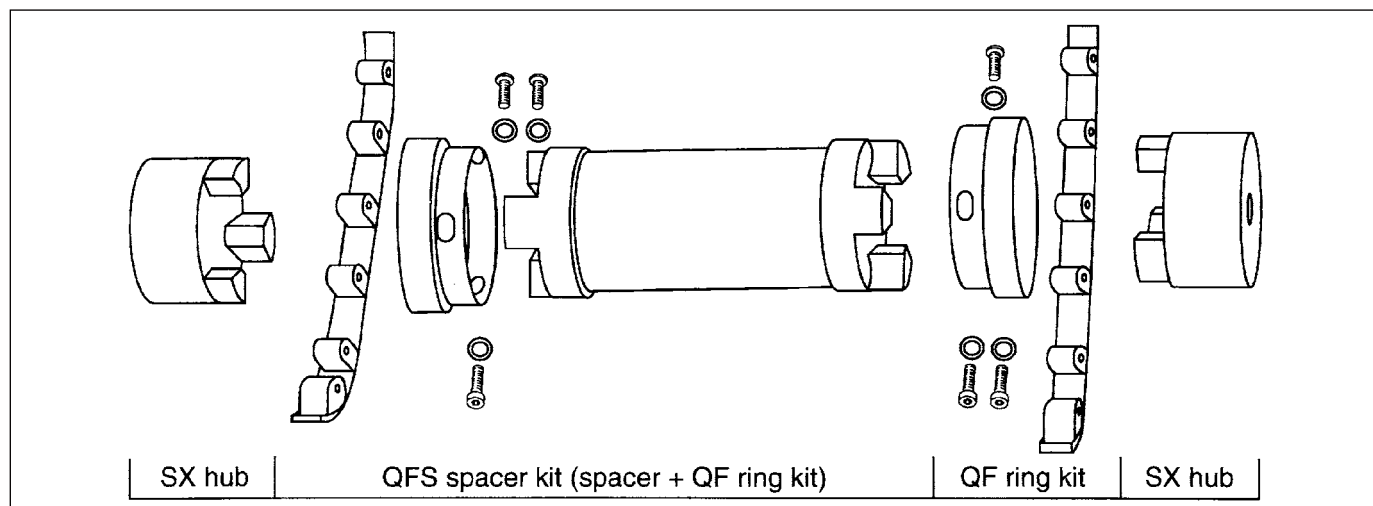

Taper Lock Rigid Couplings provide a convenient method of rigidly connecting ends of shafts. Taper Lock bushes permit easier and quicker fixing to the shafts with the firmness of a shrunk-on-fit. These

couplings have a male and female flange fully machined. The male flange can have the bush fitted from the Hub side **H** or from the Flange side **F**, the female flange always has the bush fitting **F**. This gives

two possible coupling assemblies **HF** and **FF**. When connecting horizontal shafts, the most convenient assembly should be chosen. **When connecting vertical shafts use assembly FF only.**

SELECTION

For all applications using standard mild steel shafting it is sufficiently accurate to select the coupling by consideration of bore size alone.

If transmitted torque is known, this should be checked against the allowable torque for the appropriate Taper Lock bush size/bore shown on page 128.

For all other applications consult your local Authorised Distributor.

Rotational speed should be limited to a maximum rim speed of 33 m/sec.

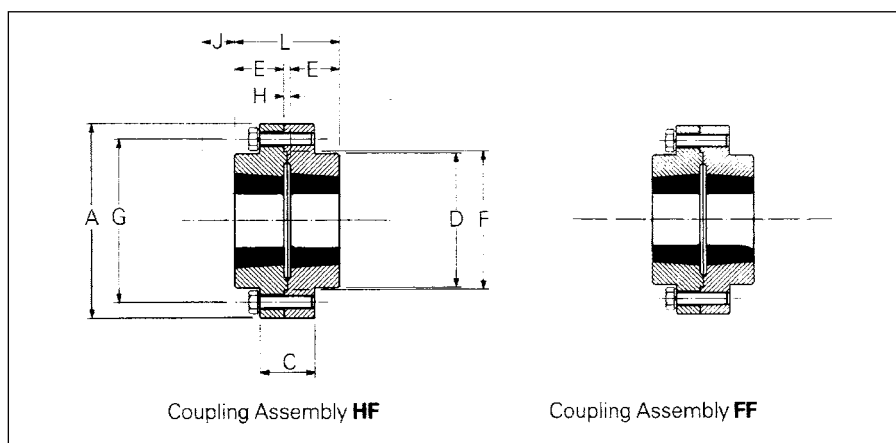
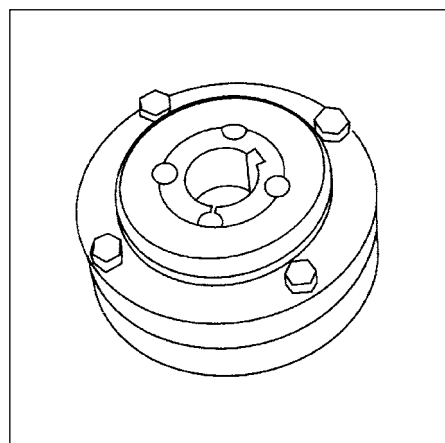

DIMENSIONS

Size	Bush No.	Max. Bore		A	C	D	E	F nominal	G nominal	H†	J*	L	Mass‡ (kg)
		Metric	Inch										
RM12	1210	32	1 1/4"	118	35	83	25	76	102	7	38	57	3.5
RM16	1610	42	1 5/8"	127	43	80	25	89	105	7	38	57	4.0
RM25	2517	60	2 1/2"	178	51	123	45	127	149	7	48	97	11.0
RM30	3020	75	3"	216	65	146	51	152	181	7	54	109	20.0
RM35	3525	100	4"	248	75	178	65	178	213	7	67	137	34.0
RM40	4030	110	4 1/2"	298	76	210	76	216	257	7	79	159	59.0
RM45	4535	125	5"	330	86	230	89	241	286	7	89	185	80.0
RM50	5040	125	5"	362	92	266	102	267	314	7	92	211	135.0

All dimensions in millimetres unless otherwise stated.

* J is the wrench clearance to allow for tightening and loosening the bushing on the shaft. The use of a shortened wrench will permit this dimension to be reduced.

† H is the distance between shaft ends.

‡ Masses given are for couplings with mid-range bore Taper Lock Bushes.

CODE NUMBERS

Size	Catalogue Code HF	Catalogue Code FF
RM12	039A0501	039A0502
RM16	039B0501N	039B0502N
RM25	039C0501	039C0502
RM30	039D0501N	039D0502N
RM35	039E0501N	039E0502N
RM40	039F0501N	039F0502N
RM45	039G0501N	039G0502N
RM50	039H0501N	039H0502N



SHAFT ALIGNMENT

Appropriate alignment of the coupled shafts (or driven shaft to flywheel) is a fundamental requirement for any coupling installation.

The three basic modes of shaft misalignment are shown right.

Composite i.e. more than one mode, misalignment is available for some couplings (detailed elsewhere in this Manual).

Details of the degrees of misalignment that can be accommodated by different types and sizes of coupling are given throughout this manual.

With some couplings, axial shaft orientation (DBSE) is not critical, whereupon coupling component orientation (given as an 'assembled length' or 'distance between faces') becomes crucial.

It should be remembered that misalignment can cause extra loading on coupled shaft support bearings and can reduce the operational life of some couplings. Best practical alignment is therefore desirable.

Taper Lock Rigid Couplings cannot accommodate misalignment.

Laser alignment equipment can be supplied.

OTHER CRITERIA

Fenaflex – tyre gap and seating. Tyre/element clamping bolt torque.

HRC – do not use to couple resiliently mounted machinery.

All Elastomeric Couplings – consider ambient conditions (FRAS or other alternative element material required?)

All Taper Lock Couplings – remember bush grips shaft first and draws hub on to taper. This may affect axial alignment.

All applications – ensure shaft diameter tolerances are correct.

Note: Fenaflex tyres and flywheel elements are accompanied by detailed installation data.

TAPER LOCK

Most of the Fenaflex and HRC couplings, and all Rigid couplings featured in this section use Taper Lock shaft fixing.

For detailed instructions on the fitting and dismantling of Taper Lock products see Shaft Fixings page 129.

Note: When fitting Taper Lock coupling flanges it should be noted that the bush grips the shaft initially and draws the flange up the tapered surface.

This may have a small effect on the final axial positioning of flanges on machine shafts, and the resultant distance between coupling flanges, where this is important to the fit and function of flexible coupling elements.

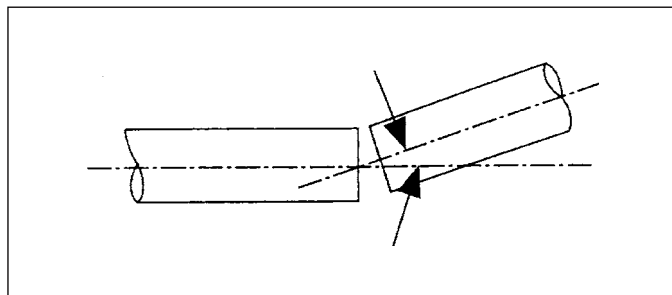

ANGULAR MISALIGNMENT – shafts are at an angle to one another

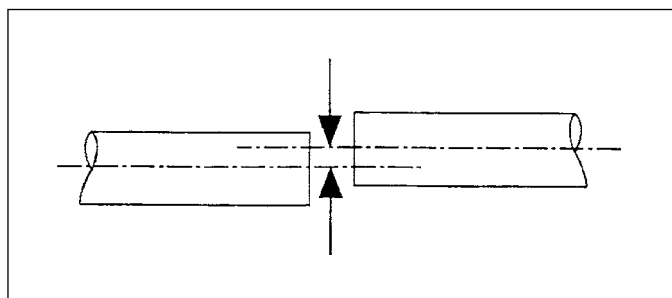

PARALLEL MISALIGNMENT – shafts are in line angularly and parallel to each other, but are off-set radially.

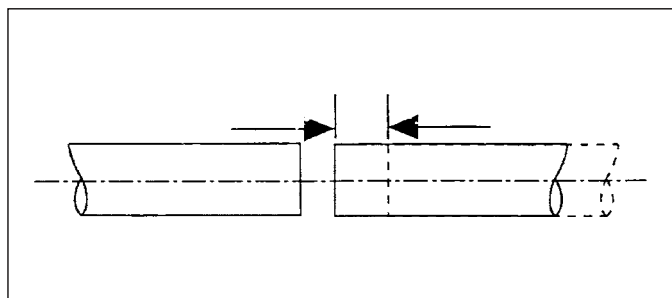

AXIAL MISALIGNMENT – refers to errors in the axial spacing of coupling hubs/flanges, but also includes applicational "end float" where shafts move axially increasing or decreasing the distance between shaft ends.

ERIKS vestigingen Aandrijftechniek

Dordrecht

Keerweer 41
3316 KA Dordrecht
T (078) 652 21 21
F (078) 652 21 29
E info.dordrecht@eriks.nl

Groningen

Rouaanstraat 8
9723 CD Groningen
T (050) 368 49 49
F (050) 314 62 57
E info.groningen@eriks.nl

Leeuwarden

James Wattstraat 19
8912 AS Leeuwarden
T (058) 294 50 50
F (058) 213 24 71
E info.leeuwarden@eriks.nl

Roermond

Albert Einsteinweg 8
6045 GX Roermond
T (0475) 37 22 33
F (0475) 32 75 40
E info.roermond@eriks.nl

Rotterdam

Sevillaweg 75
3047 AL Rotterdam
T (010) 245 50 00
F (010) 262 06 22
E info.rotterdam@eriks.nl

Schoonhoven

Broeikweg 25
2871 RM Schoonhoven
T (0182) 30 34 56
F (0182) 38 69 20
E info.schoonhoven@eriks.nl

ERIKS Servicecenters

Alkmaar

Saffierstraat 3
1812 RM Alkmaar
T (072) 514 17 17
F (072) 514 16 25
E esc.alkmaar@eriks.nl

Almelo

Plesmanweg 12
7602 PE Almelo
T (0546) 87 30 70
F (0546) 87 32 68
E almelo@eriks.nl

Amsterdam

Dynamostraat 46-48
1014 BK Amsterdam-Westpoort
T (020) 448 96 10
F (020) 613 77 65
E amsterdam@eriks.nl

Arnhem

Pieter Calandweg 46
6827 BK Arnhem
T (026) 362 92 44
F (026) 361 00 63
E arnhem@eriks.nl

Bergen op Zoom

Van Konijnenburgweg 44 b
4612 PL Bergen op Zoom
T (0164) 27 55 44
F (0164) 27 55 49
E bergenopzoom@eriks.nl

Delfzijl

Deltaweg 30
9936 HK Farmsum
T (0596) 63 38 20
F (0596) 63 38 29
E delfzijl@eriks.nl

Den Haag

Neckar 2
2491 BD Den Haag
T (070) 381 84 84
F (070) 381 84 36
E denhaag@eriks.nl

Doetinchem

Havenstraat 55
7005 AG Doetinchem
T (0314) 34 37 20
F (0314) 34 37 41
E doetinchem@eriks.nl

Ede

Galvanistraat 34
6716 AE Ede
T (0318) 43 96 14
F (0318) 64 01 04
E ede@eriks.nl

Eerbeek

Loubergweg 19
6961 EJ Eerbeek
T (0313) 67 95 00
F (0313) 65 47 68
E eerbeek@eriks.nl

Eindhoven

De Witbogt 22 a
5652 AG Eindhoven
T (040) 291 19 00
F (040) 291 19 09
E eindhoven@eriks.nl

Emmen

Willem Schoutenstraat 11 b
7825 VV Emmen
T (0591) 66 80 00
F (0591) 66 80 06
E emmen@eriks.nl

Hengelo

Hassinkweg 16
7556 BV Hengelo
T (074) 291 57 57
F (074) 291 59 39
E hengelo@eriks.nl

Hoorn

De Factorij 35 d
1689 AK Zwaag
T (0229) 21 28 82
F (0229) 21 93 74
E hoorn@eriks.nl

Gouda

Marconistraat 117
2809 PG Gouda
T (0182) 33 11 60
F (0182) 37 82 02
E gouda@eriks.nl

Groningen

Rouaanstraat 8
9723 CD Groningen
T (050) 368 49 99
F (050) 368 49 98
E groningen@eriks.nl

Leeuwarden

James Wattstraat 19
8912 AS Leeuwarden
T (058) 215 05 87
F (058) 215 85 16
E leeuwarden@eriks.nl

Maastricht

Amerikalaan 28
6199 AE Maastricht-Airport
T (043) 604 91 80
F (043) 363 87 28
E maastricht@eriks.nl

Rijnmond

Shannonweg 33, Haven 5079
3197 LG Rotterdam-Botlek
T (010) 231 34 00
F (010) 296 96 18
E rijnmond@eriks.nl

Rotterdam

Cairostraat 80
3047 BC Rotterdam
T (010) 245 50 55
F (010) 262 00 38
E rotterdam@eriks.nl

Roermond

Ada Byronweg 11
6045 GM Roermond
T (0475) 37 22 70
F (0475) 37 23 05
E roermond@eriks.nl

Tilburg

Ellen Pankhurststraat 9
5032 MD Tilburg
T (013) 571 45 61
F (013) 570 06 42
E tilburg@eriks.nl

Zwolle

Ampèrestraat 27
8013 PT Zwolle
T (038) 467 29 20
F (038) 467 29 29
E zwolle@eriks.nl



www.eriks.nl

Afdichtingstechniek | Stroomingstechniek | Kunststoffen | Aandrijftechniek | Gereedschappen & Onderhoudsproducten

kennis maakt het verschil

ERIKS