

Falk™ Wrapflex® Elastomer Couplings | Talk About Simple! (English-Inch)

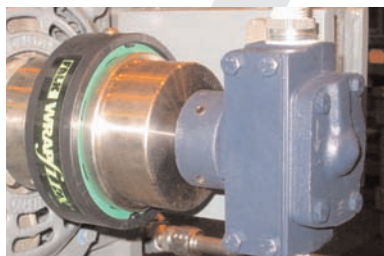
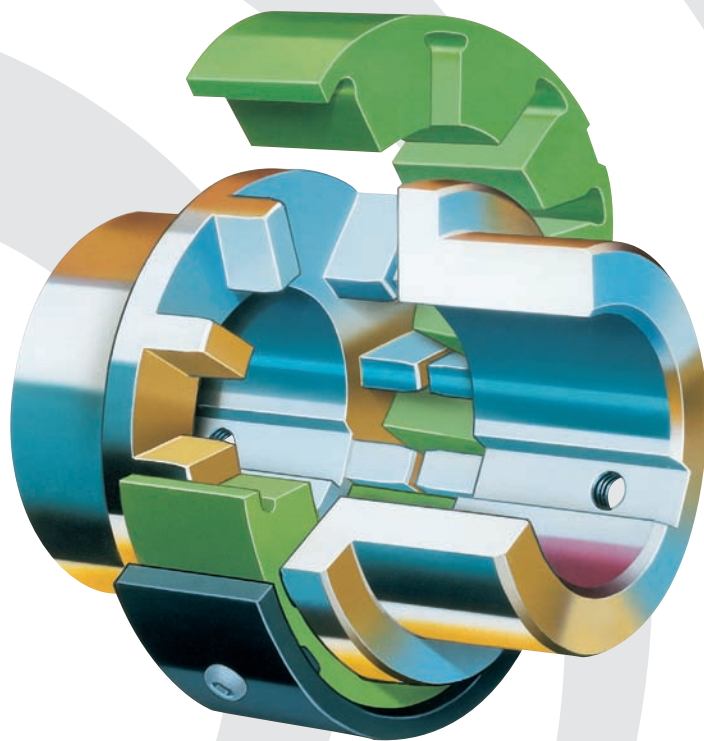

Falk™ Wrapflex® Elastomer Couplings Now There's a Simple Way to Increase Productivity

- 9 sizes
- Torque Range: 133,000 lb.in. (15 028 Nm)
 - Bore Capacity: 7¼" (186 mm)
 - "Replace in Place"
 - Non-Lubricated/Low Maintenance
 - 3-Year Heavy-Duty Warranty

Ever think that keeping your production lines running more profitably could be as simple as replacing a light bulb or opening a can with a pop-top?

Quick, easy installation and replacement set new standards for reduced downtime. Because motors or drives don't need to be moved, our "replace in place" elements even eliminate the need for time-consuming realignment, further reducing downtime.

Available in close-coupled and spacer designs, Wrapflex couplings accommodate up to 7¼" (186 mm) shafts and torque loads up to 133,000 lb.in. (15 028 Nm).

For simplicity and cost-effectiveness over the life of your coupling, it just doesn't get any easier than this – Wrapflex couplings from Rexnord.

Low Initial Cost

- Advanced manufacturing methods and innovative material allow us to offer you higher capacity ratings at a more competitive price than ever before possible.
- Initial investment protected by the industry's first, standard 3-Year Heavy-Duty Warranty.

Easy to Install

- The compound root radius in the element teeth (patent applied for) increases flexibility for easier and quicker assembly.
- Can be blind assembled from either direction.

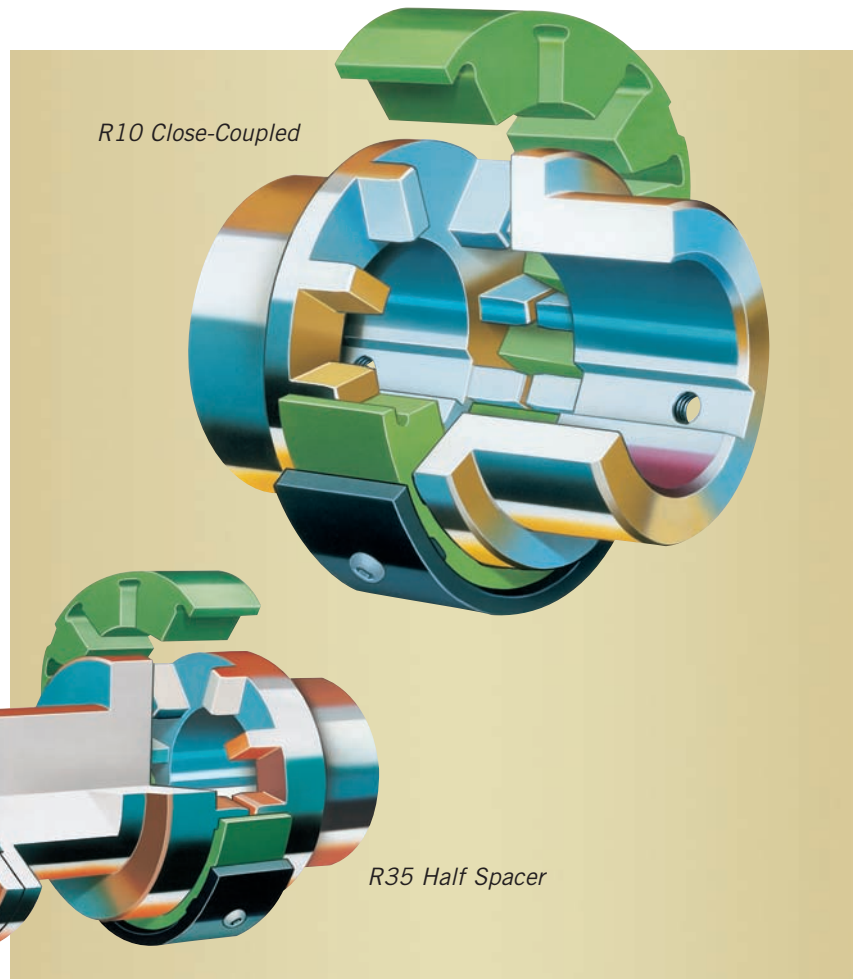



Tough, Long-Lasting

- Polyurethane element has excellent wear and chemical resistance, and a operating temperature of -40° C (-40° F) to 95° C (200° F).
- Hubs made from carbon steel for maximum strength. Optional stainless steel hubs also available.
- Weather-resistant, high-grade nylon cover is standard.
- Optional carbon steel covers with black epoxy coating for highly corrosive, severe-duty applications. (Standard for sizes 60-80.)
- Optional Stainless steel hubs are available for Type R10 when required in food or corrosive environments.

Safety First

- Two stainless steel button-head cap screws, positioned 180° apart, prevent relative motion between cover and element and provide a positive means of retaining the cover to the element.
- Flexible element is retained after failure, helping minimize the potential for damage or personal injury.

Replace in Place

- Design allows quick and easy element replacement.
- There's no need to remove hubs or realign motors or drives, reducing downtime.

No Maintenance Needed

- Non-lubricated design of the tough, flexible polyurethane element reduces periodic maintenance costs.

Protects Equipment

- Patent applied for design of the flexible element minimizes effects of misalignment for improved performance and life.

Quick and Easy Retrofits

- Compact design eliminates the need for coupling guard redesign on existing applications.
- Stock finished bores in popular sizes and taper bores, which accept Q.D. and TaperLock bushings, are available from our worldwide distribution network for off-the-shelf availability.

R31 Full Spacer

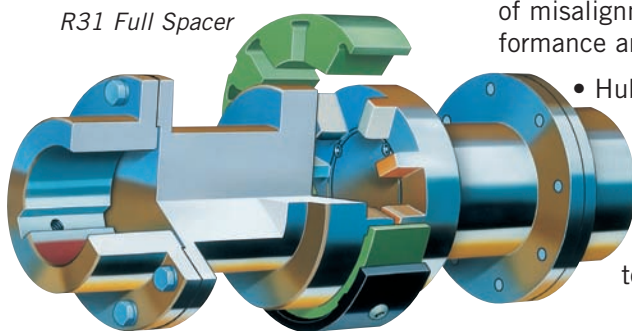

- Hub teeth machined with special nose radius (patent No. 6,342,011) for better tooth-to-tooth contact.

Falk™ Wrapflex® Selection Guide

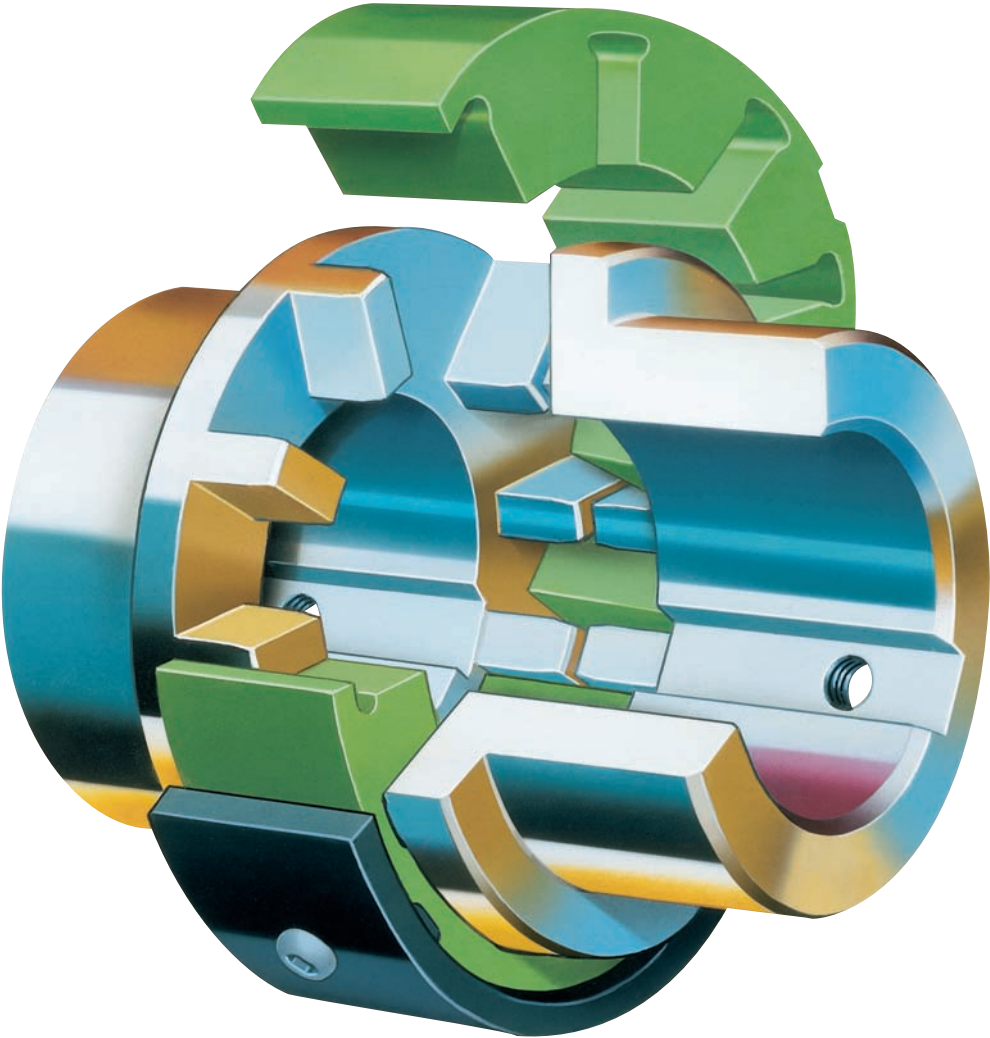

Selection Guide 491-110, June 2004

Wrapflex Quick Selection Method

1. Determine Service Factor — Refer to Table 1 or 4 for motor or turbine driven applications. See Table 5 for Engine Drives.
2. Determine Equivalent Horsepower:
Refer to Table 2 — Under the actual hp required and opposite the service factor, read the equivalent hp.
3. Determine Coupling Size:
- A. Refer to Table 3 — Trace horizontally from the required speed to a hp value equal to or larger than the equivalent hp determined in Step 2. Read the coupling size at the top of the column.
- B. Check shaft diameters against coupling maximum bores shown in Table 3 and on Page 8 for the correct coupling size selected.
- C. In Table 3, check the required speed against the allowable speed shown below the correct coupling size selected.
4. Determine Coupling Dimensional Requirements:
- A. Determine application/design shaft spacing and check application dimension requirements against selected coupling type dimensions shown on Pages 8 thru 12. Confirm sufficient clearances for coupling.
5. Confirm that application ambient operating temperatures are between -40°C (-40°F) to 95°C (200°F). For applications requiring Service Factor above 1.5 and temperatures above 79°C (175°F), consult Falk Engineering for selection assistance or optional high temperature elements.

SERVICE FACTORS are a guide, based on experience, of the ratio between coupling catalog rating and system characteristics. The system characteristics are best measured with a torque meter.

TABLE 1 — Service Factors







Torque Demands Driven Machine	Typical applications for electric motor or turbine driven equipment	Typical Service Factor
	Constant torque such as Centrifugal Pumps, Blowers, and Compressors.	1.0
	Continuous duty with some torque variations including Plastic extruders, Forced Draft Fans.	1.5
	Light shock loads from Metal Extruders, Cooling Towers, Cane Knife, Log Haul.	2.0
	Moderate shock loading as expected from a Car Dumper, Stone Crusher, Vibrating Screen.	2.5
	Heavy shock load with some negative torques from Roughing Mills, Reciprocating Pumps, Compressors, Reversing Runout Tables.	3.0
	Applications like Reciprocating Compressors with frequent torque reversals, which do not necessarily cause reverse rotations.	Refer to Falk

TABLE 2 — Equivalent Horsepower = (Actual hp x Service Factor)

Service Factor ‡	Actual HP																									
	3/4	1	1½	2	3	5	7½	10	15	20	25	30	40	50	60	75	100	125	150	200	250	300	350	400	450	500
1.0	.75	1.0	1.5	2.0	3.0	5.0	7.5	10	15	20	25	30	40	50	60	75	100	125	150	200	250	300	350	400	450	500
1.25	.94	1.25	1.9	2.5	3.8	6.3	9.4	12.5	19	25	31	38	50	63	75	94	125	156	188	250	312	375	438	500	563	625
1.5	1.1	1.5	2.3	3.0	4.5	7.5	11.3	15	23	30	38	45	60	75	90	113	150	188	225	300	375	450	525	600	675	750
1.75	1.3	1.8	2.6	3.5	5.3	8.8	13.1	18	26	35	44	53	70	88	105	131	175	219	262	350	438	525	613	700	787	875
2.0	1.5	2.0	3.0	4.0	6.0	10.0	15.0	20	30	40	50	60	80	100	120	150	200	250	300	400	500	600	700	800	900	1000
2.5	1.9	2.5	3.8	5.0	7.5	12.5	18.8	25	38	50	63	75	100	125	150	187	250	312	375	500	625	750	875	1000	1125	1250
3.0	2.3	3.0	4.5	6.0	9.0	15.0	22.5	30	45	60	75	90	120	150	180	225	300	375	450	600	750	900	1050	1200	1350	1500
3.5	2.6	3.5	5.3	7.0	10.5	17.5	26.2	35	52	70	87	105	140	175	210	262	350	437	525	700	875	1050	1225	1400	1575	1750

‡ For service factors not listed, Equivalent hp = Actual hp x Service Factor.

© Rexnord Industries, LLC 1998, 2004. All Rights Reserved. Litho in U.S.A.
A-PLUS, CLUB GEAR HEAD, DRIVE ONE, FALK, FREEDOM, LIFELIGN, OMNIBOX, ORANGE PEEL, QUADRIVE, RAM, RENEW, REXNORD, SPEED QUOTE, SPEEDSELECT, STEELFLEX, TRUE HOLD, and ULTRAMITE, ULTRAMAX, and WRAPFLEX are registered trademarks. The contents of this bulletin are subject to change without notice or obligation. Information contained herein should be confirmed before placing orders.

TABLE 3 — Falk “Wrapflex” Coupling Quick Selection Chart

	5R	10R	20R	30R	40R	50R	60R	70R	80R
Max Bore (Inches)	1.625	1.875	2.375	2.875	3.375	4.125	5.250	6.125	7.250
Max Speed	4500 rpm	4500 rpm	4500 rpm	4500 rpm	3600 rpm	3000 rpm	2500 rpm	2100 rpm	1800 rpm
Torque (lb-in)	550	1150	2800	4600	9100	22,200	35,500	70,900	133,000
HP/100 rpm	0.87	1.82	4.44	7.3	14.4	35.2	56.3	112.5	211.0
RPM	HP Ratings								
4500	39.3	82.1	200	328					
3600	31.4	65.7	160	263	520				
3000	26.2	54.7	133	219	433	1057			
2500	21.8	45.6	111	182	361	881	1408		
2100	18.3	38.3	93.3	153	303	740	1183	2362	
1800	15.7	32.8	80.0	131	260	634	1014	2025	3798
1750	15.3	31.9	77.7	128	253	616	986	1969	3693
1450	12.7	26.5	64.4	106	209	511	817	1631	3060
1170	10.2	21.3	52.0	85.4	169	412	659	1316	2469
1000	8.7	18.2	44.4	73.0	144	352	563	1125	2110
870	7.6	15.9	38.7	63.5	126	306	490	979	1836
720	6.3	13.1	32.0	52.6	104	254	406	810	1519
650	5.7	11.9	28.9	47.4	93.9	229	366	731	1372
580	5.1	10.6	25.8	42.3	83.7	204	327	652	1224
520	4.5	9.5	23.1	38.0	75.1	183	293	585	1097
420	3.7	7.7	18.7	30.7	60.6	148	237	472	886
350	3.1	6.4	15.5	25.5	50.5	123	197	394	739
280	2.4	5.1	12.4	20.4	40.4	98.6	158	315	591
230	2.0	4.2	10.2	16.8	33.2	81.0	130	259	485
190	1.7	3.5	8.4	13.9	27.4	66.9	107	214	401
155	1.4	2.8	6.9	11.3	22.4	54.6	87.3	174	327
125	1.1	2.3	5.6	9.1	18.0	44.0	70.4	141	264
100	.87	1.8	4.4	7.3	14.4	35.2	56.3	112	211
84	.73	1.5	3.7	6.1	12.1	29.6	47.3	94.5	177
68	.59	1.2	3.0	5.0	9.8	24.0	38.3	76.5	143
56	.49	1.02	2.5	4.1	8.1	19.7	31.5	63.0	118
45	.39	.82	2.0	3.3	6.5	15.9	25.3	50.6	95.0
3768	1.6	2.7	5.3	13.0	20.8	41.6	78.1
3055	1.3	2.2	4.3	10.6	16.9	33.7	63.3
25	1.1	1.8	3.6	8.8	14.1	28.1	52.8
2089	1.5	2.9	7.0	11.3	22.5	42.2
16.573	1.2	2.4	5.8	9.29	18.6	34.8
1358	.95	1.9	4.6	7.32	14.6	27.4

Service Factors

TABLE 4 — Flexible Coupling Service Factors for Motor ♦ and Turbine Drives

Service factors listed are typical values based on normal operation of the drive systems.

Alphabetical listing of applications		Alphabetical listing of industries	
	Service Factor		Service Factor
AERATOR	2.0	AGGREGATE PROCESSING, CEMENT, MINING KILNS; TUBE, ROD AND BALL MILLS	
AGITATORS		Direct or on L.S. shaft of	
Vertical and Horizontal		Reducer, with final drive	
Screw, Propeller, Paddle.....	1.0	Machined Spur Gears.....	2.0
BARGE HAUL PULLER	1.5	Single Helical or	
BLOWERS		Herringbone Gears.....	1.75
Centrifugal.....	1.0	Conveyors, Feeders, Screens,	
Lobe or Vane.....	1.25	Elevators.....	See General Listing
CAR DUMPERS	2.5	Crushers, Ore or Stone.....	2.5
CAR PULLERS	1.5	Dryer, Rotary.....	1.75
CLARIFIER OR CLASSIFIER	1.0	Grizzly.....	2.0
COMPRESSORS		Hammermill or Hog.....	1.75
Centrifugal.....	1.0	Tumbling Mill or Barrel.....	1.75
Rotary, Lobe or Vane.....	1.25	BREWING AND DISTILLING	
Rotary, Screw.....	1.0	Bottle and Can	
Reciprocating		Filling Machines.....	1.0
Direct Connected.....	Refer to Factory	Brew Kettle.....	1.0
Without Flywheel.....	Refer to Factory	Cookers, Continuous Duty.....	1.25
*With Flywheel and Gear		Lauter Tub.....	1.5
between Compressor		Mash Tub.....	1.25
and Prime Mover		Scale Hopper, Frequent Peaks.....	1.75
1 cylinder, single acting.....	3.0	CLAY WORKING INDUSTRY	
1 cylinder, double acting.....	3.0	Brick Press, Briquette Machine,	
2 cylinders, single acting.....	3.0	Clay Working Machine,	
2 cylinders, double acting.....	3.0	Pug Mill.....	1.75
3 cylinders, single acting.....	3.0	DREDGES	
3 cylinders, double acting.....	2.0	Cable Reel.....	1.75
4 or more cyl., single act.....	1.75	Conveyors.....	1.25
4 or more cyl., double act.....	1.75	Cutter head, Jig Drive.....	2.0
CONVEYORS		Maneuvering Winch.....	1.5
Apron, Assembly, Belt, Chain,		Pumps (uniform load).....	1.5
Flight, Screw.....	1.0	Screen Drive, Stacker.....	1.75
Bucket.....	1.25	Utility Winch.....	1.5
Live Roll, Shaker and		FOOD INDUSTRY	
Reciprocating.....	3.0	Beet Slicer.....	1.75
CRANES AND HOIST		Bottling, Can Filling Machine.....	1.0
Main Hoist.....	1.75▲	Cereal Cooker.....	1.25
Skip Hoist.....	1.75▲	Dough Mixer, Meat Grinder.....	1.75
Slope.....	1.5	LUMBER	
Bridge, Travel or Trolley.....	1.75	Band Resaw.....	1.5
DYNAMOMETER	1.0	Circular Resaw, Cut-off.....	1.75
ELEVATORS		Edger, Head Rig, Hog.....	2.0
Bucket, Centrifugal Discharge.....	1.25	Gang Saw	
Freight or Passenger.....	Not Approved	(Reciprocating).....	Refer to Factory
Gravity Discharge.....	1.25	Log Haul.....	2.0
ESCALATORS	Not Approved	Planer.....	1.75
EXCITER, GENERATOR	1.0	Rolls, Non-Reversing.....	1.25
EXTRUDER, PLASTIC	1.5	Rolls, Reversing.....	2.0
FANS		Sawdust Conveyor.....	1.25
Centrifugal.....	1.0	Slab Conveyor.....	1.75
Cooling Tower.....	2.0	Sorting Table.....	1.5
Forced Draft — Across the		Trimmer.....	1.75
Line start.....	1.5	METAL ROLLING MILLS	
Forced Draft Motor		Coilers (Up or Down) Cold	
Driven thru fluid or		Mills only.....	1.5
electric slip clutch.....	1.0	Coilers (Up or Down) Hot	
Gas Recirculating.....	1.5	Mills only.....	2.0
Induced Draft with damper		Coke Plants	
control or blade cleaner.....	1.25	Pusher Ram Drive.....	2.5
Induced Draft without controls.....	2.0	Door Opener.....	2.0
FEEDERS		Pusher or Larry Car	
Apron, Belt, Disc, Screw.....	1.0	Traction Drive.....	3.0
Reciprocating.....	2.5	Continuous Caster.....	1.75
GENERATORS		Cold Mills —	
Even Load.....	1.0	Strip Mills.....	Refer to Factory
Hoist or Railway Service.....	1.5	Temper Mills.....	Refer to Factory
Welder Load.....	2.0	Cooling Beds.....	1.5
HAMMERMILL	1.75	Drawbench.....	2.0
LAUNDRY WASHER OR TUMBLER	2.0	Feed Rolls - Blooming Mills.....	3.0
LINE SHAFTS		Furnace Pushers.....	2.0
Any Processing Machinery.....	1.5	Hot and Cold Saws.....	2.0
MACHINE TOOLS		Hot Mills —	
Auxiliary and Traverse Drive.....	1.0	Strip or Sheet Mills.....	Refer to Factory
Bending Roll, Notching Press,		Reversing Blooming.....	Refer to Factory
Punch Press, Planer, Plate		or Slabbing Mills.....	Refer to Factory
Reversing.....	1.75	Edger Drives.....	Refer to Factory
Main Drive.....	1.5	Ingot Cars.....	2.0
MAN LIFTS	Not Approved	Manipulators.....	3.0
METAL FORMING MACHINES		Merchant Mills.....	Refer to Factory
Continuous Caster.....	1.75	Mill Tables	
Draw Bench Carriage and		Roughing Breakdown	
Main Drive.....	2.0	Mills.....	3.0
Extruder.....	2.0	Hot Bed or Transfer,	
Farming Machine and		non-reversing.....	1.5
Forming Mills.....	2.0	Runout, reversing.....	3.0
Slitters.....	1.0	Runout, non-reversing,	
Wire Drawing or Flattening.....	1.75	non-plugging.....	2.0
Wire Winder.....	1.5	Reel Drives.....	1.75
Coilers and Uncoilers.....	1.5	Rod Mills.....	Refer to Factory
MIXERS (see Agitators)		Screwdown.....	2.0
Concrete.....	1.75	Seamless Tube Mills	
Muller.....	1.5	Piercer.....	3.0
PRESS, PRINTING	1.5	Thrust Block.....	2.0
PUG MILL	1.75	Tube Conveyor Rolls.....	2.0
PULVERIZERS		Reeler.....	2.0
Hammermill and Hog.....	1.75	Kick Out.....	2.0
Roller.....	1.5	AGGREGATE PROCESSING, CEMENT, MINING KILNS; TUBE, ROD AND BALL MILLS	
PUMPS		Reducer, with final drive	
Boiler Feed.....	1.5	Machined Spur Gears.....	2.0
Centrifugal —		Single Helical or	
Constant Speed.....	1.0	Herringbone Gears.....	1.75
Frequent Speed Changes		Conveyors, Feeders, Screens,	
under Load.....	1.25	Elevators.....	See General Listing
Descaling, with accumulators.....	1.25	Crushers, Ore or Stone.....	2.5
Gear, Rotary, or Vane.....	1.25	Dryer, Rotary.....	1.75
Reciprocating, Plunger Piston		Grizzly.....	2.0
1 cyl., single or double act.....	3.0	Hammermill or Hog.....	1.75
2 cyl., single acting.....	2.0	Tumbling Mill or Barrel.....	1.75
2 cyl., double acting.....	1.75	BREWING AND DISTILLING	
3 or more cylinders.....	1.5	Bottle and Can	
Screw Pump, Progressing Cavity.....	1.25	Filling Machines.....	1.0
Vacuum Pump.....	1.25	Brew Kettle.....	1.0
SCREENS		Cookers, Continuous Duty.....	1.25
Air Washing.....	1.0	Lauter Tub.....	1.5
Grizzly.....	2.0	Mash Tub.....	1.25
Rotary Coal or Sand.....	1.5	Scale Hopper, Frequent Peaks.....	1.75
Vibrating.....	2.5	CLAY WORKING INDUSTRY	
Water.....	1.0	Brick Press, Briquette Machine,	
SKI TOWS & LIFTS	Not Approved	Clay Working Machine,	
STEERING GEAR	1.0	Pug Mill.....	1.75
STOKER	1.0	DREDGES	
TIRE SHREDDER	1.50	Cable Reel.....	1.75
TUMBLING BARREL	1.75	Conveyors.....	1.25
WINCH, MANEUVERING		Cutter head, Jig Drive.....	2.0
Dredge, Marine.....	1.5	Maneuvering Winch.....	1.5
WINDLASS	1.5	Pumps (uniform load).....	1.5
WOODWORKING MACHINERY	1.0	Screen Drive, Stacker.....	1.75
WORK LIFT PLATFORMS	Not Approved	Utility Winch.....	1.5

♦ For engine drives, refer to Table 5. Electric motors, generators, engines, compressors and other machines fitted with sleeves or straight roller bearings usually require limited end float couplings. If in doubt, provide axial clearances and centering forces to the Factory for a recommendation.

* For balanced opposed design, refer to the Factory.

▲ If people are occasionally transported, refer to the Factory for the selection of the proper size coupling.

♣ For high peak load applications (such as Metal Rolling Mills) refer to the Factory.

TABLE 5 — Engine Drive Service Factors ▼

Service Factors for engine drives are those required for applications where good flywheel regulation prevents torque fluctuations greater than ±20%. For drives where torque fluctuations are greater or where the operation is near a serious critical or torsional vibration, a mass elastic study is necessary.

No. of Cylinders	4 or 5 ▼					6 or more ▼				
	1.0	1.25	1.5	1.75	2.0	1.0	1.25	1.5	1.75	2.0
Table 4 S.F.	1.0	1.25	1.5	1.75	2.0	1.0	1.25	1.5	1.75	2.0
Engine S.F.	2.0	2.25	2.5	2.75	3.0	1.5	1.75	2.0	2.25	2.5

▼ To use Table 5, first determine application service factor from Table 4. Use that factor to determine ENGINE Service Factor from Table 5. When service factor from Table 4 is greater than 2.0, or where 1, 2, or 3 cylinder engines are involved, refer complete application details to Rexnord Engineering.

Type R10

Close Coupled Coupling/Dimensions — Inches

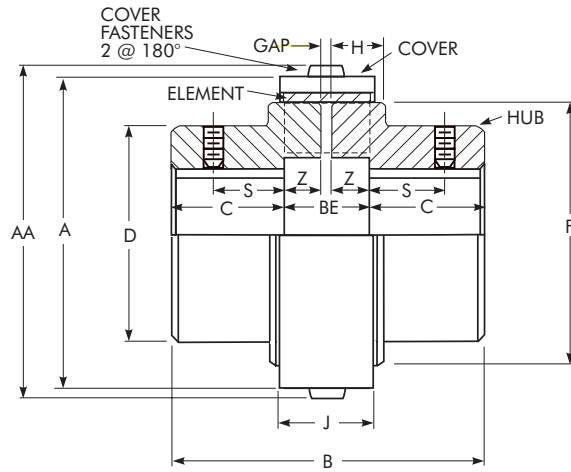

DIMENSIONS — INCHES †

SIZE ★	Torque Rating lb-in	Allow Speed rpm	Max Bore Std Hub Mount ◆	Max Bore Protruded Shaft ▲	Cplg Wt No Bore - lb		A		AA		B	BE	C	D	F	H	J		S ▲	Z	Gap	Cover Fasteners ■	
					Nylon Cover	Steel Cover ●	Nylon Cover	Steel Cover ●	Nylon Cover	Steel Cover ●							Nylon Cover	Steel Cover ●				Size	Allen Wrench Tool
5R	550	4,500	1.625	1.500	2.96	3.26	3.01	3.01	3.17	3.17	2.82	0.77	1.02	2.36	2.520	0.59	0.91	0.91	0.63	0.35	.062	M4	M2.5
10R	1,150	4,500	1.875	1.750	5.47	5.96	3.56	3.56	3.72	3.72	3.61	0.93	1.34	2.83	2.992	0.75	1.10	1.10	0.88	0.43	.062	M4	M2.5
20R	2,800	4,500	2.375	2.250	12.3	13.4	4.96	4.88	5.20	5.12	4.79	1.24	1.77	3.62	4.016	0.98	1.46	1.46	1.00	0.59	.062	M6	M4
30R	4,600	4,500	2.875	2.500	20.7	22.1	5.77	5.63	6.01	5.87	5.97	1.40	2.28	4.13	4.646	1.14	1.65	1.64	1.25	0.67	.062	M6	M4
40R	9,100	3,600	3.375	3.125	37.6	39.9	7.17	6.97	7.48	7.28	7.12	1.84	2.64	5.12	5.906	1.34	2.15	2.09	1.63	0.83	.188	M8	M5
50R	22,200	3,000	4.125	4.125	74.4	78.5	9.09	8.82	9.41	9.13	8.46	2.39	3.03	6.69	7.480	1.81	2.74	2.65	1.75	1.10	.188	M8	M5
60R	35,500	2,500	5.250	5.250	...	137	...	10.51	...	10.94	10.83	2.96	3.94	7.87	8.976	2.37	...	2.64	...	1.39	.188	M10	M6
70R	70,900	2,100	6.125	6.125	...	217	...	12.20	...	12.64	12.76	3.31	4.72	8.94	10.630	2.74	...	2.95	...	1.56	.188	M10	M6
80R	133,000	1,800	7.250	7.250	...	364	...	14.57	...	15.00	14.85	3.82	5.51	10.63	12.913	3.28	...	3.35	...	1.79	.250	M10	M6

★ Standard urethane element operating temperature: -40°C (-40°F) to 95°C (200°F). Dimensions are for reference and are subject to change without notice unless certified.

† Inch/metric conversions may not be direct conversions.

● 5R-50R nylon cover is standard & epoxy coated steel cover is optional. 60R-80R epoxy coated steel cover is standard (nylon cover not available).

■ Cover Fasteners are ISO 7380 Stainless Steel Socket Button Head Cap screws. Two cover fasteners per coupling.

▲ A protruded shaft is defined as the shaft penetrating into the area shown above as Dimension "Z". Size 5R-50R are standard "clearance" fit with keyway and 2 setscrews (one over keyway & one at 90° from keyway). 60R-80R are standard "interference" fit with keyway & no setscrew.

◆ The number of application start/stop cycles should be limited to 10 per hour at the maximum bore condition unless long hubs are utilized. For applications with a Service Factor requirement of 2.0 or more, refer to Falk for possible use of long hubs for additional shaft engagement or utilization of Interference Fits.

Type R10

QD Bushings/Dimensions — Inches

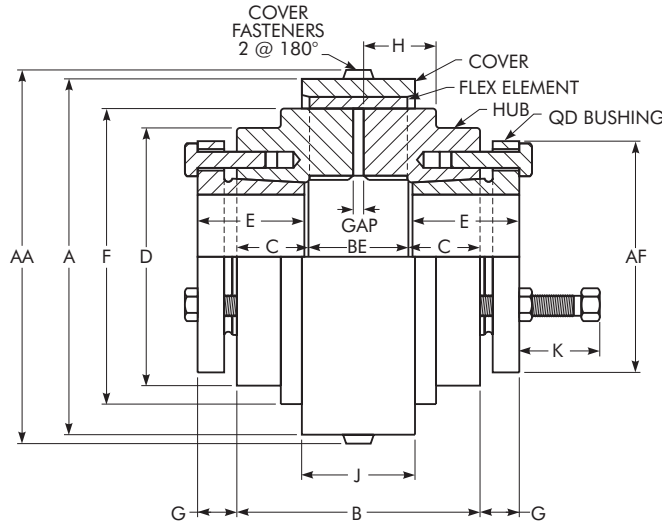

COUPLING SIZE	Bushing Size	Torque Rating	HP per 100 rpm	Max RPM	Max Bore †	Min Bore †	Coupling Weight without Bushing		Gap	BE
		lb-in			Inch	Inch	Nylon Cover – lb	Steel Cover – lb		
5R	JA	550	0.87	4500	1.250	0.500	2.13	2.43	0.063	0.77
10R	JA *	1150	1.82	4500	1.250	0.500	3.49	3.99	0.063	0.93
20R	SD	2800	4.44	4500	1.938	0.500	6.73	7.78	0.063	1.24
30R	SD	4600	7.3	4500	1.938	0.500	10.2	11.6	0.063	1.40
40R	SF	9100	14.4	3600	2.938	0.500	17.0	19.2	0.188	1.84
50R	E *	22200	35.2	3000	3.500	0.875	36.8	40.9	0.188	2.39
60R	J	35500	56.3	2500	4.500	1.438	NA	82.8	0.188	2.96
70R	J *	70900	112.5	2100	4.500	1.438	NA	126	0.188	3.31
80R	M * †	133000	211.0	1800	5.500	1.938	NA	254	0.250	3.82

COUPLING SIZE	Cover Fasteners *		Bushing Fasteners * Inch Hardware	AA – Nylon Cover	AA – Steel Cover	A – Nylon Cover	A – Steel Cover	AF ■	B
	Size	Hex Tool							
5R	M4	M2.5	#10-24 x 1.00	3.17	3.17	3.01	3.01	2.00	2.82
10R	M4	M2.5	#10-24 x 1.00	3.72	3.72	3.56	3.56	2.00	2.98
20R	M6	M4	1/4-20 x 1.00	5.20	5.12	4.96	4.88	3.19	3.76
30R	M6	M4	1/4-20 x 1.00	6.01	5.87	5.77	5.63	3.19	3.92
40R	M8	M5	3/8-16 x 1.25	7.48	7.28	7.17	6.97	4.63	4.52
50R	M8	M5	1/2-13 x 1.75	9.41	9.13	9.09	8.82	6.00	5.70
60R	M10	M6	5/8-11 x 2.50	...	10.94	...	10.51	7.25	9.34
70R	M10	M6	5/8-11 x 2.50	...	12.64	...	12.20	7.25	9.69
80R	M10	M6	3/4-10 x 3.00	...	15.00	...	14.57	9.13	14.22

COUPLING SIZE	C	D	E ■	F	G ■	H	J – Nylon Cover	J – Steel Cover	K – Clearance
	Inch								
5R	1.02	2.36	1.00	2.520	0.44	0.59	0.91	0.91	1.16
10R	1.02	2.83	1.00	2.992	0.44	0.75	1.10	1.10	1.16
20R	1.26	3.62	1.81	4.016	0.56	0.98	1.46	1.46	1.19
30R	1.26	4.13	1.81	4.646	0.56	1.14	1.65	1.64	1.19
40R	1.34	5.12	2.00	5.906	0.84	1.34	2.15	2.09	1.50
50R	1.65	6.69	2.63	7.480	1.13	1.81	2.74	2.65	2.13
60R	3.19	8.03	4.50	8.976	1.50	2.37	...	2.64	2.94
70R	3.19	8.94	4.50	10.630	1.50	2.74	...	2.95	2.94
80R	5.20	10.63	6.75	12.913	1.66	3.28	...	3.35	3.50

★ Refer to specific bushing manufacturer for torque capacity actual ratings.

† 80R requires a special "M" bushing, manufactured for "reverse" mounting. Consult bushing manufacturer.

‡ Typical – refer to bushing manufacturer for exceptions.

● Cover Fasteners are ISO 7380, Stainless Steel, Socket Button Head Cap Screws. Bushing fasteners are SAE Grade 5 (inch) or ISO 8.8 (metric), Hex Head Cap Screws.

■ May vary depending on bushing manufacturer. Consult bushing manufacturer.

Type R10

Taper-Lock Bushings/Dimensions — Inches

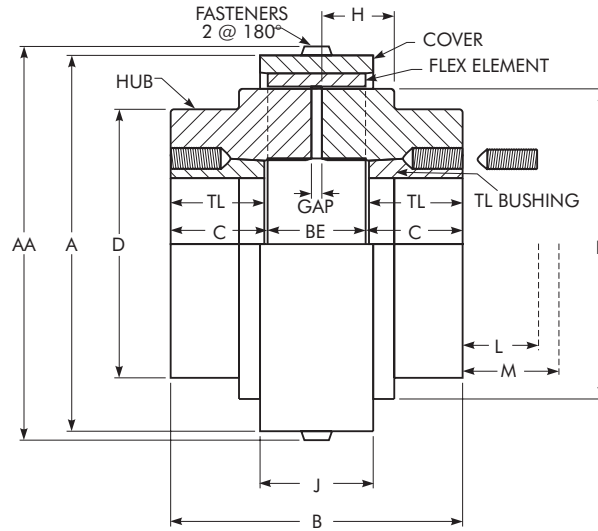

COUPLING SIZE	Bushing Size	Assembly Torque Rating ★ lb-in	HP Per 100 rpm	Max RPM	Max Bore ★ Inch	Min Bore ★ Inch	Coupling Weight w/o Bushing		Gap Inch
							Nylon Cover lb	Steel Cover lb	
5R	1108	550	0.87	4500	1.125	0.500	1.78	2.08	0.063
10R	1210	1,150	1.82	4500	1.250	0.500	3.44	3.93	0.063
20R	1610	2,800	4.44	4500	1.625	0.500	6.86	7.91	0.063
30R	2012	4,600	7.3	4500	2.000	0.500	10.7	12.1	0.063
40R	2517	9,100	14.4	3600	2.500	0.500	19.4	21.7	0.188
50R	3020	22,200	35.2	3000	3.250	0.875	40.9	45.0	0.188
60R	4040	35,500	56.3	2500	4.438	1.438	...	85.9	0.188
70R	4545	70,900	112	2100	4.938	1.938	...	134	0.188
80R	5050	126,000	200	1800	5.313	2.438	...	238	0.250

COUPLING SIZE	BE	Cover Fasteners †		A – Nylon Cover	A – Steel Cover	AA – Nylon Cover	AA – Steel Cover	B	C
	Inch	Size	Hex Tool	Inch	Inch	Inch	Inch	Inch	Inch
5R	0.77	M4	M2.5	3.01	3.01	3.17	3.17	2.54	0.89
10R	0.93	M4	M2.5	3.56	3.56	3.72	3.72	3.53	1.30
20R	1.24	M6	M4	4.96	4.88	5.20	5.12	3.84	1.30
30R	1.40	M6	M4	5.77	5.63	6.01	5.87	4.71	1.65
40R	1.84	M8	M5	7.17	6.97	7.48	7.28	5.46	1.81
50R	2.39	M8	M5	9.09	8.82	9.41	9.13	6.72	2.17
60R	2.96	M10	M6	...	10.51	...	10.94	11.07	4.06
70R	3.31	M10	M6	...	12.20	...	12.64	12.37	4.53
80R	3.82	M10	M6	...	14.57	...	15.00	13.90	5.04

COUPLING SIZE	D	F	H	J - Nylon Cover	J - Steel Cover	L ‡		M •		TL Inch
	Inch	Inch	Inch	Inch	Inch	Standard Hex Key	Short ■ Hex Key	Standard Hex Key	Short ■ Hex Key	
5R	2.36	2.520	0.59	0.91	0.91	1.125	0.625	1.250	0.750	0.875
10R	2.83	2.992	0.75	1.10	1.10	1.375	0.813	1.625	1.063	1.000
20R	3.62	4.016	0.98	1.46	1.46	1.375	0.813	1.625	1.063	1.000
30R	4.13	4.646	1.14	1.65	1.64	1.563	0.938	2.000	1.375	1.250
40R	5.12	5.906	1.34	2.15	2.09	1.625	1.000	2.250	1.625	1.750
50R	6.69	7.480	1.81	2.74	2.65	1.813	1.188	2.688	2.063	2.000
60R	7.87	8.976	2.37	...	2.64	2.375	1.625	4.125	3.375	4.000
70R	8.94	10.630	2.74	...	2.95	2.625	1.938	4.750	4.063	4.500
80R	10.63	12.913	3.28	...	3.35	2.813	2.313	5.250	4.813	5.000

★ Typical – refer to bushing manufacturer for exceptions and Service Factor limitations.

† Cover Fasteners are ISO 7380, Stainless Steel, Socket Button Head Cap Screws.

‡ Space required to tighten bushing. Also, space required to loosen screws to permit removal of hub by puller.

• Space required to remove bushing using jackscrews – no puller required.

■ Standard hex key cut to minimum useable length.

Type R31

Full Spacer Coupling/Dimensions — Inches

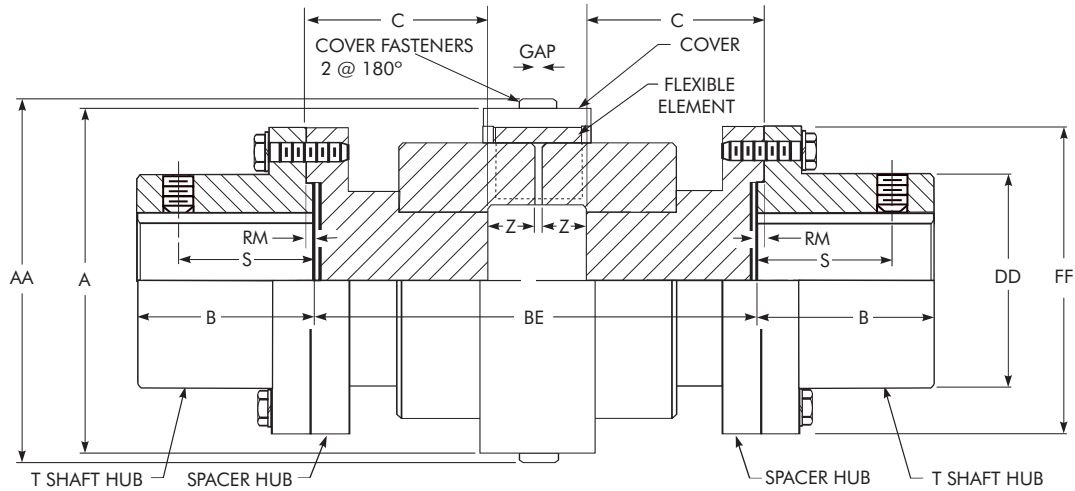

NOTE: Distance Between Shaft Ends (BE) = 2(C) + 2(Z) + Gap - 2(RM)
SPACER DIMENSIONS — INCHES

SIZE ★	Torque Rating lb-in	Allow Speed rpm	Max Bore ♦	Cplg Wt No Bore — lb		BE		A		AA		B	DD	FF	RM	S	Z	Gap	Cover Fasteners •		Flange Fasteners ■		T Shaft Hub
				At Min lb	Per Added BE lb/in	Min	Max	Nylon Cover	Steel Cover †	Nylon Cover	Steel Cover †								Size	Allen Wrench Tool	Size	No. Per Flange	
				5R	550	4500	1.375	8.0	0.79	3.19	9.25								3.01	3.01	3.17	1.38	
10R	1,150	4500	1.625	11.0	0.86	3.50	10.00	3.56	3.56	3.72	1.63	2.34	3.70	0.05	1.240	0.43	0.062	M4	M2.5	M6	8	1030T	
20R	2,800	4500	2.125	21.0	1.49	3.50	10.00	4.96	4.88	5.20	2.13	3.09	4.45	0.05	1.080	0.59	0.062	M6	M4	M6	8	1040T	
30R	4,600	4500	2.375	31.0	1.88	4.38	10.00	5.77	5.63	6.01	2.38	3.44	4.96	0.05	1.600	0.67	0.062	M6	M4	M8	8	1050T	
40R	9,100	3600	3.125	57.0	2.23	5.00	12.25	7.17	6.97	7.48	3.13	4.31	6.02	0.05	1.840	0.83	0.188	M8	M5	M10	12	1070T	
50R	22,200	3000	3.500	100.0	3.31	6.50	12.25	9.09	8.82	9.41	3.50	4.81	7.01	0.05	1.960	1.10	0.188	M8	M5	M12	12	1080T	
60R	35,500	2500	4.000	160.0	4.57	7.87	12.25	...	10.51	...	10.94	4.00	5.63	8.27	0.05	...	1.39	0.188	M10	M6	M16	12	1090T
70R	70,900	2100	4.750	225.0	6.59	8.80	14.70	...	12.20	...	12.64	3.56	6.75	9.88	0.06	...	1.56	0.188	M10	M6	M20	12	1100T
70R	70,900	2100	5.500	265.0	6.59	8.80	14.70	...	12.20	...	12.64	4.10	7.75	10.88	0.06	...	1.56	0.188	M10	M6	M20	12	1110T
80R	133,000	1800	6.250	415.0	8.10	9.85	16.69	...	14.57	...	15.00	4.70	8.88	12.56	0.06	...	1.79	0.250	M10	M6	M24	12	1120T
80R	133,000	1800	7.000	505.0	13.60	10.07	16.69	...	14.57	...	15.00	5.30	9.38	13.63	0.06	...	1.79	0.250	M10	M6	M27	12	1130T

★ Standard urethane element operating temperature: -40°C (-40°F) to 95°C (200°F). Dimensions are for reference only and are subject to change without notice unless certified.)

† 5R-50R nylon cover is standard & epoxy coated steel cover is optional. 60R-80R epoxy coated steel cover is standard (nylon cover not available.)

• Cover Fasteners are ISO 7380 Stainless Steel Socket Button Head Cap Screws. Two cover fasteners per coupling.

■ Flange Fasteners are ISO Grade 10.9 hex head cap screws for 5R-50R and ISO Grade 8.8 hex head cap screws for 60R.

♦ Maximum Inch Bore listed is for a standard square key. Larger bores, with a rectangular key, are available. Sizes 5R-50R are standard clearance fit with setscrew over keyway. Size 60R is standard interference fit with keyway, but no setscrew. For interference fit with setscrew over keyway, refer to 427-105.

TABLE 6 — Taper-Lock® Bushings for T Shaft Hubs

CPLG SIZE	T Shaft Hub	Assembly Torque Rating lb-in	HP per 100 rpm	Allow Speed	Bore Range	Bushings Size
10R	1030T	1,150	1.82	4500	.500-1.125	1108
20R	1040T	2,800	4.44	4500	.500-1.375	1310
30R	1050T	4,300	6.82	4500	.500-1.625	1615
40R	1070T	9,100	14.4	3600	.750-2.500	2525
50R	1080T	11,300	17.9	3000	.750-2.500	2525
60R	1090T	24,000	38.1	2500	.938-3.000	3030
70R	1100T	24,000	38.1	2100	.938-3.000	3030
70R	1110T	44,000	71.1	2100	1.19-3.500	3535
80R	1120T	77,300	122	1800	1.44-4.000	4040
80R	1130T	110,000	174	1800	1.94-4.500	4545

TABLE 7 — Type R31 Standard Spacer Lengths — Inches

CPLG SIZE	BE Lengths (Distance Between Shaft Ends)					
	3.50	4.38	5.00	7.25	9.75	10.00
5R	X	X	X
10R	X	X	X	X
20R	X	X	X	X
30R	...	X	X	X
40R	X	X	X	...
50R	X	X	X
60R	X	...

Other BE lengths available. Refer to the Factory.

Type R35

Half Spacer Coupling/Dimensions — Inches

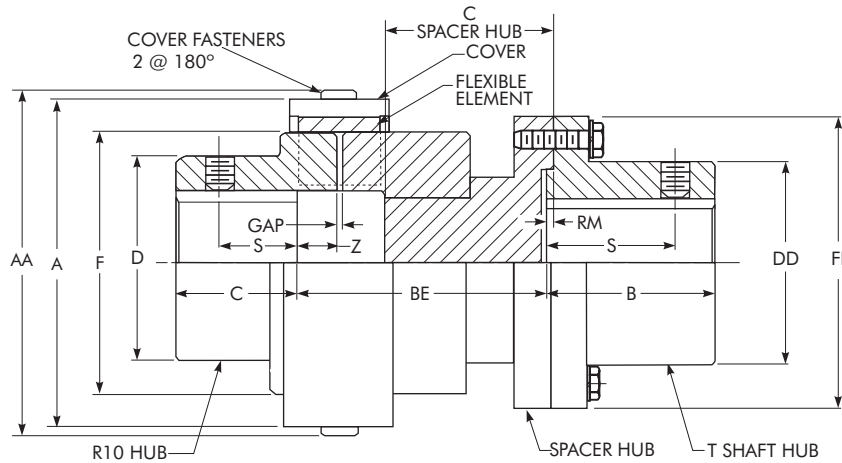

NOTE: Distance Between Shaft Ends (BE) = (C)_{Spacer Hub} + 2(Z) + Gap - RM
SPACER DIMENSIONS — INCHES

SIZE ★	Torque Rating lb-in	Allow Speed rpm	Max Bore ♦		Cplg Wt No Bore - lb		BE		A		AA		B	C R10 Hub	D	DD	F	FF	RM	S		Z	Gap	Cover Fasteners ●		Flange Fasteners ■		T Shaft Hub
			T Shaft Hub	R10 Hub	At Min BE	Per Added BE lb/in	Min	Max	Nylon Cover	Steel Cover †	Nylon Cover	Steel Cover †								Shaft Hub *	R10 Hub *			Size	Allen Wrench Tool	Size	No. Per Flange	
5R	550	4500	1.375	1.625	5.61	0.79	1.99	5.00	3.01	3.01	3.17	3.17	1.38	1.02	2.36	2.06	2.52	3.39	0.05	1.08	0.63	0.35	0.062	M4	M2.5	M6	4	1020T
10R	1,150	4500	1.625	1.875	8.73	0.86	2.35	5.51	3.56	3.56	3.72	3.72	1.63	1.34	2.83	2.34	2.99	3.70	0.05	1.24	0.88	0.43	0.062	M4	M2.5	M6	8	1030T
20R	2,800	4500	2.125	2.375	18.6	1.49	3.01	5.51	4.96	4.88	5.20	5.12	2.13	1.77	3.62	3.09	4.02	4.45	0.05	1.08	1.00	0.59	0.062	M6	M4	M6	8	1040T
30R	4,600	4500	2.375	2.875	28.4	1.88	3.45	5.75	5.77	5.63	6.01	5.87	2.38	2.28	4.13	3.44	4.65	4.96	0.05	1.60	1.25	0.67	0.062	M6	M4	M8	8	1050T
40R	9,100	3600	3.125	3.375	49.4	2.23	3.49	7.25	7.17	6.97	7.48	7.28	3.13	2.64	5.12	4.31	5.91	6.02	0.05	1.84	1.63	0.83	0.188	M8	M5	M10	12	1070T
50R	22,200	3000	3.500	4.125	88.9	3.31	4.45	7.25	9.09	8.82	9.41	9.13	3.50	3.03	6.69	4.81	7.48	7.01	0.05	1.96	1.75	1.10	0.188	M8	M5	M12	12	1080T
60R	35,550	2500	4.000	5.250	148	4.57	5.42	8.00	...	10.51	...	10.94	4.00	3.94	7.87	5.63	8.98	8.27	0.05	1.39	0.188	M10	M6	M16	12	1090T
70R	70,900	2100	4.750	6.125	220	6.55	6.06	9.01	...	12.20	...	12.64	3.56	4.72	8.94	6.75	10.63	9.88	0.06	1.56	0.197	M10	M6	M20	12	1100T
70R	70,900	2100	5.510	6.125	240	6.55	6.06	9.01	...	12.20	...	12.64	4.10	4.72	8.94	7.75	10.63	10.88	0.06	1.56	0.197	M10	M6	M20	12	1110T
80R	133,000	1800	6.250	7.250	390	8.04	6.80	10.22	...	14.57	...	15.00	4.70	5.51	10.63	8.88	12.91	12.56	0.06	1.79	0.236	M10	M6	M24	12	1120T
80R	133,000	1800	7.000	7.250	425	13.44	6.91	10.22	...	14.57	...	15.00	5.30	5.51	10.63	9.37	12.91	13.62	0.06	1.79	0.236	M10	M6	M27	12	1130T

★ IMPORTANT: Upon removal of spacer hub, working clearance available for equipment removal = "BE" - "Z".

Standard urethane element operating temperature: -40°F (-40°C) to 200°F (95°C). Dimensions are for reference and are subject to change without notice unless certified.

† 5R-50R nylon cover is standard & epoxy coated steel cover is optional. 60R-80R epoxy coated steel cover is standard (nylon cover not available).

● Cover Fasteners are ISO 7380 Stainless Steel Socket Button Head Cap Screws. Two cover fasteners per coupling.

■ Flange Fasteners are ISO Grade 10.9 hex head cap screws for 5R-50R, and ISO Grade 8.8 hex head cap screws for 60R-80R.

♦ For R10 hubs see Page 8 for "Max Bore Protuded Shaft" along with the footnote. Maximum Inch Bore listed is for a standard square key. For T shaft hubs only, larger inch bores with a rectangular key are available. Sizes 5R-50R are standard clearance fit with setscrew(s) over keyway. Sizes 60R - 80R are standard interference fit with keyway, but no setscrew. For interference fit with setscrew over keyway, refer to 427-105. For R10 hubs at the Max Bore condition, limit the number of start/stop cycles to 10 per hour unless long hubs are used.

* Standard for T shaft hub is one setscrew over keyway; standard for R10 hub is two setscrews (one over keyway and one at 90° from keyway), Sizes 5-50R.

TABLE 8 — R35 Standard Spacer Lengths

Size	BE	Z	Usable Clearance Gap
5R	2.143	0.35	1.793
	2.362	0.35	2.012
	2.581	0.35	2.231
	2.893	0.35	2.543
	3.500	0.35	3.150
10R	2.004	0.43	1.574
	2.441	0.43	2.011
	2.660	0.43	2.230
	2.973	0.43	2.543
	3.228	0.43	2.798
	3.500	0.43	3.070
	3.937	0.43	3.507
	4.098	0.43	3.668
20R	1.775	0.59	1.185
	2.070	0.59	1.480
	2.510	0.59	1.920
	2.986	0.59	2.396
	3.130	0.59	2.540
	3.386	0.59	2.796
	3.500	0.59	2.910
	3.937	0.59	3.347
	4.255	0.59	3.665

TABLE 8 — R35 Standard Spacer Lengths

Size	BE	Z	Usable Clearance Gap
30R	2.332	0.67	1.662
	2.952	0.67	2.282
	3.464	0.67	2.794
	4.333	0.67	3.663
	5.000	0.67	4.330
40R	3.425	0.83	2.595
	3.681	0.83	2.851
	4.468	0.83	3.638
	4.550	0.83	3.720
	5.000	0.83	4.170
	5.800	0.83	4.970
50R	4.745	1.10	3.645
	4.826	1.10	3.726
	6.076	1.10	4.976
	6.201	1.10	5.101
60R	6.359	1.39	4.969

Other BE lengths available. Refer to the Factory.

Taper-Lock bushing for R10 hub, see Page 10.

QD bushing for R10 hub, see Page 9.

Taper-Lock bushing for T shaft hub, see Table 6, Page 11.

Engineering Data

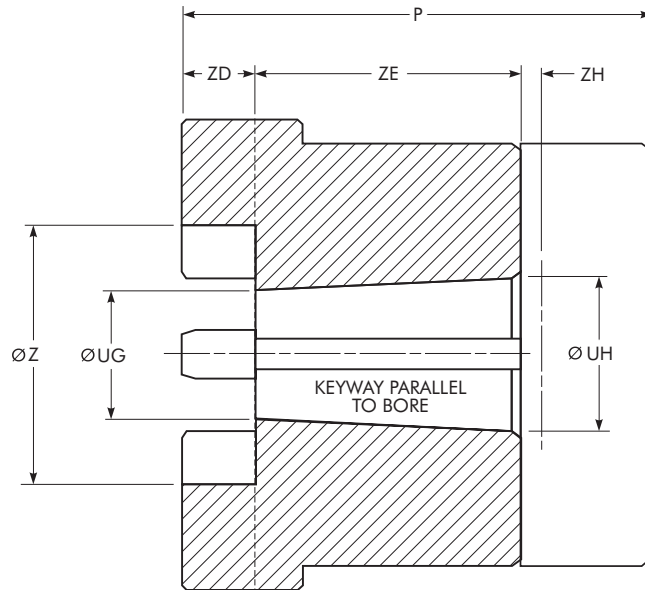

TABLE 11 — Standard AISE AC & DC Mill Motor Coupling Selections

Motor Frame Sizes			Coupling Size	Torque Rating (lb-in)	Ø UG	Ø UH	Ø Z	Keyway	ZD	ZE	ZH +.000 -.000
2, 602	802 A,B,C	AC 1, 2, 4	40R † 50R	9,100 22,200	1.438	1.750	3.181 4.173	.500 x .250 .500 x .250	0.83 1.10	3.00	.024
603, 604	803, 804	...	50R 60R	22,200 35,500	1.635	2.000	4.173 5.315	.500 x .250 .500 x .250	1.10 1.39	3.50	.029
606	806	AC 8, 12	50R † 60R 70R	22,200 35,550 70,900	2.083	2.500	4.173 5.315 6.299	.500 x .250 .500 x .250 .500 x .250	1.10 1.39 1.56	4.00	.029
608	808	...	60R 70R 80R	35,550 70,900 133,000	2.531	3.000	5.315 6.299 7.480	.750 x .250 .750 x .250 .750 x .250	1.39 1.56 1.79	4.50	.029
610	810	AC 18	70R 80R	70,900 133,000	2.781	3.250	6.299 7.480	.750 x .250 .750 x .250	1.56 1.79	4.50	.034
612	812	AC 25, 30	70R 80R	70,900 133,000	3.104	3.625	6.299 7.480	.750 x .250 .750 x .250	1.56 1.79	5.00	.034
614	814	AC 40, 50	80R	133,000	3.729	4.250	7.480	1.000 x .375	1.79	5.00	.034

† Must use "standard" socket on mill motor nut. "Impact" socket will not fit.

TABLE 12 — Taper & Counter Bore Limitations

Coupling Size	P Max	Ø UG Min	Ø UH Max	Ø Z Max	ZD Max	ZE Min	Keyway *
5R	2.40	.500	1.500	1.535	.362	.827	.375 x .188
10R	3.11	.500	1.750	1.811	.441	1.000	.375 x .188
20R	4.13	.750	2.250	2.311	.598	1.063	.500 x .250
30R	5.24	1.000	2.500	2.559	.677	1.339	.625 x .313
40R	6.10	1.125	3.125	3.181	.835	1.339	.750 x .375
50R	7.17	1.125	4.125	4.173	1.110	1.811	1.000 x .500
60R	7.29	1.250	5.250	5.315	1.394	2.126	1.250 x .625
70R	8.65	1.500	6.125	6.299	1.571	2.244	1.500 x .750
80R	10.06	1.500	7.250	7.480	1.795	2.618	1.750 x .875

* Keyway shown is for maximum bore with square key.

TABLE 13 — Type R10 Mill Motor Hubs

Mill Motor Frame Size			R10 Flex Hubs								
			5R	10R	20R	30R	40R	50R	60R	70R	80R
602	802 A, B, C	AC 1, 2 & 4	X	X
603 604	803 804		Consult Falk	X	X
606	806	AC 8 & 12	X	X	X	...
608	808		X	X	X
610	810	AC 18	Consult Falk	X	X
612	812	AC 25 & 50	X	X
614	814	AC 40 & 50	X	X

Engineering Data

TABLE 14 — Operating Misalignment Capacity

COUPLING SIZE	Parallel Offset (Inch)	Angular (Degrees)
5R	.04	1°
10R	.08	1°
20R	.08	1°
30R	.08	1°
40R	.12	1°
50R	.12	1°
60R	.12	1°
70R	.12	1°
80R	.12	1°

TABLE 15 — Mass and WR2

R10 Mass						
COUPLING SIZE	Element	Nylon Cover	Steel Cover	R10 Hub (No Bore)	Total w/Nylon Cover	Total w/Steel Cover
	lb	lb	lb	lb	lb	lb
5R	0.0736	0.0700	0.370	1.41	2.96	3.26
10R	0.132	0.100	0.590	2.62	5.46	5.96
20R	0.408	0.240	1.29	5.84	12.3	13.4
30R	0.626	0.370	1.82	9.83	20.7	22.1
40R	1.30	0.860	3.13	17.7	37.6	39.9
50R	2.70	1.70	5.83	35.0	74.4	78.5
60R	4.08	NA	7.29	63.1	NA	137
70R	6.17	NA	10.2	100	NA	217
80R	10.2	NA	14.6	169	NA	364

R10 WR ²						
COUPLING SIZE	Element	Nylon Cover	Steel Cover	R10 Hub (No Bore)	Total w/Nylon Cover	Total w/Steel Cover
	lb-in ²	lb-in ²	lb-in ²	lb-in ²	lb-in ²	lb-in ²
5R	0.0907	0.14	0.76	1.05	2.33	2.95
10R	0.2291	0.30	1.7	2.79	6.10	7.50
20R	1.348	1.3	7.0	10.5	23.7	29.4
30R	2.747	2.8	13.2	23.2	51.9	62.3
40R	8.843	10.06	35.3	65.4	150	175
50R	30.4	31.82	106	218	499	573
60R	67.8	NA	188	557	NA	1370
70R	141	NA	358	1189	NA	2877
80R	334	NA	740	2939	NA	6952

R31/R35 WR ² Values ★									
SIZE	T31 Shaft Hub	R31 Assembly †				R35 Assembly ‡			
		Min BE (inch)	WR ² at Min BE (lb-in ²)		WR ² (lb-in ²) per Inch	Min BE (inch)	WR ² at Min BE (lb-in ²)		WR ² (lb-in ²) per Inch
			Nylon Cover	Steel Cover			Nylon Cover	Steel Cover	
5R	1020	3.19	7.53	8.15	0.351	1.99	4.93	5.55	0.351
10R	1030	3.50	13.6	15.0	0.413	2.35	9.58	11.0	0.413
20R	1040	3.50	39.1	44.8	1.253	3.01	32.6	38.3	1.253
30R	1050	4.38	71.8	82.2	1.980	3.45	65.3	75.7	1.980
40R	1070	5.00	217	243	4.164	3.49	184	209	4.164
50R	1080	6.50	579	654	10.78	4.45	539	613	10.78
60R	1090	7.87	N.A.	1459	20.35	5.42	N.A.	1415	20.35
60R	1100	9.60	N.A.	2050	23.79	6.28	N.A.	1710	23.79
70R	1100	8.80	N.A.	2967	40.58	6.06	N.A.	2922	40.58
70R	1110	8.80	N.A.	3617	40.58	6.06	N.A.	3247	40.58
80R	1120	9.78	N.A.	7669	61.97	6.80	N.A.	7214	61.97
80R	1130	10.00	N.A.	9611	144.83	6.91	N.A.	8185	144.83

★ WR² values are based on hubs with no bore.

† For R31 Mass, refer to Page 11.

‡ For R35 Mass, refer to Page 12.

World Class Customer Service

For more than 100 years, the dedicated people of Rexnord have delivered excellence in quality and service to our customers around the globe. Rexnord is a trusted name when it comes to providing skillfully engineered products that improve productivity and efficiency for industrial applications worldwide. We are committed to exceeding customer expectations in every area of our business: product design, application engineering, operations, and customer service.

Because of our customer focus, we are able to thoroughly understand the needs of your business and have the resources available to work closely with you to reduce maintenance costs, eliminate redundant inventories and prevent equipment down time.

Rexnord represents the most comprehensive portfolio of power transmission and conveying components in the world with the brands you know and trust.

Wrapflex and Rexnord are registered trademarks of Rexnord Industries, LLC. Falk is a trademark of Rexnord. All rights reserved.

WORLDWIDE CUSTOMER SERVICE

AUSTRALIA

Rexnord Australia Pty. Ltd.
Picton, New South Wales
Phone: 61-2-4677-3811
Fax: 61-2-4677-3812

BRAZIL

Rexnord Correntes Ltda.
Sao Leopoldo - RS
Phone: 55-51-579-8022
Fax: 55-51-579-8029

CANADA

Rexnord Canada Ltd.
Scarborough, Ontario
Phone: 1-416-297-6868
Fax: 1-416-297-6873

CHINA

Rexnord China
Shanghai, China
Phone: 86-21-62701942
Fax: 86-21-62701943

EUROPE

Rexnord NV/SA
Mechelen, Belgium
Phone: 32-15-443811
Fax: 32-15-443860

Rexnord Kette GmbH
Betzdorf, Germany
Phone: 49-2741-2840
Fax: 49-2741-284-385

LATIN AMERICA

Rexnord International, Inc.
Milwaukee, Wisconsin
Phone: 1-414-643-2366
Fax: 1-414-643-3222
E-mail: international2@rexnord.com

MEXICO

Rexnord S.A. de C.V.
Queretaro, Qro.
Phone: 52-442-218.5000
Fax: 52-.442-218-1090

SINGAPORE

Rexnord International, Inc.
Singapore City, Singapore
Phone: 65-6338-5622
Fax: 65-6338-5422

UNITED STATES

Customer Service
Phone: 1-866-REXNORD
(1-866-739-6673)
Fax: 1-614-675-1898
E-mail: [rexnordcs\(state\)@rexnord.com](mailto:rexnordcs(state)@rexnord.com)
Example: rexnordcsohio@rexnord.com

ALL COUNTRIES NOT LISTED

Rexnord International
Milwaukee, Wisconsin
Phone: 1-414-643-2366
Fax: 1-414-643-3222
E-mail: international1@rexnord.com

