

Falk™ Ultramite® Gearmotor | Interchange & Nomenclature Guide

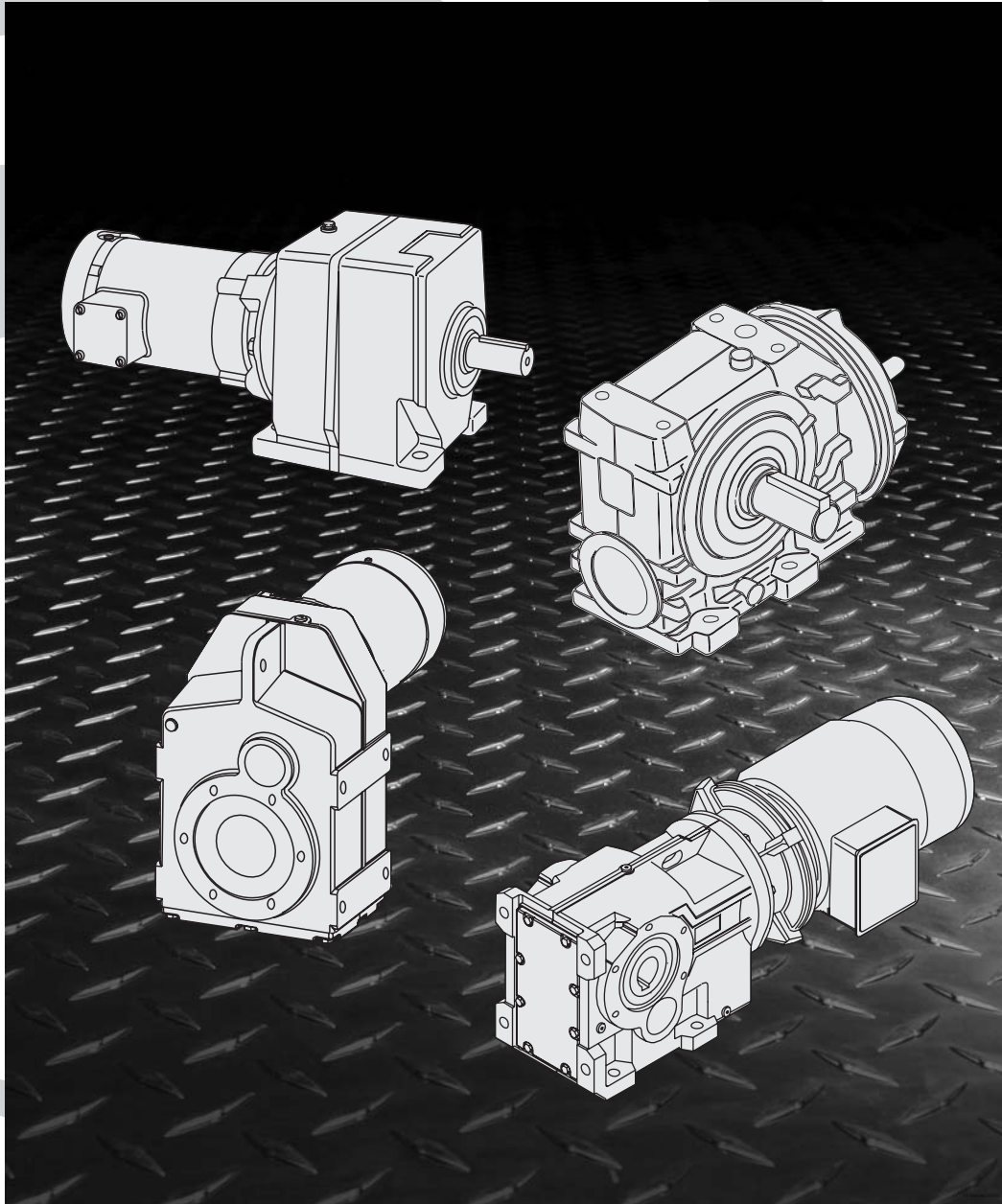

FALK ULTRAMITE®

Delivers local availability, NEMA/IEC compatibility plus drop-in replacement

It's a winning combination. Start with a compact size that's the perfect fit for the .19KW/.25HP through 37KW/100HP power range. You can choose a standard plug-in high-efficiency NEMA/IEC motor from stock for an easy bolt-up mounting to the gear drive. Add positive torque transfer without corrosion or fretting, energy efficiency over worm gear drives and quick availability no matter where you're located – and you've got the Falk Ultramite, a genuine contender in the fight for increased factory floor productivity.

What's more, the Ultramite is backed up by Rexnord, a global leader in the power transmission and conveying industry. It's got the right size, the right statistics and the right name.

The Ultramite – it delivers just the right punch.

Local availability

The Ultramite product line is assembled from a family of convenient, cost-saving kitted sub-assemblies. The Ultramite sub-assembly kits are stocked at Rexnord facilities and distributors, offering a wide range of sizes, ratios and types for assembly. This totally modular approach to your complete gear drive and spare parts requirements ensures maximum local availability with the quickest possible turnaround times. In fact, completed assemblies can be available within hours.

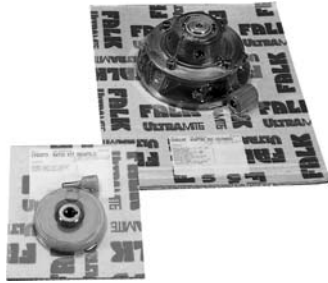

Customer preferred motors

The Ultramite accepts standard, off-the-shelf NEMA/IEC C-face and flange mounted motors, permitting the use of customer-preferred motor brands. The Ultramite accommodates industry-standard frame sizes and the choice of motor manufacturer and specifications is up to you, without costly motor adapter systems and special replacement motors – ideal for use with variable speed motors and drives.

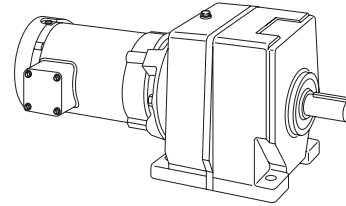

Type UC - Helical Concentric

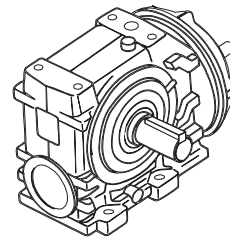

Type UW - Right-Angle Helical Worm

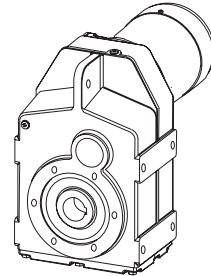

Type UJ - Shaft-Mounted Offset Helical

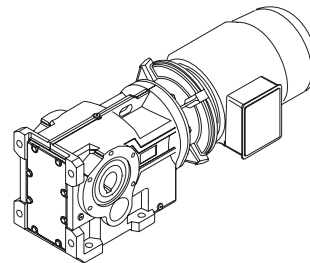

Type UB - Right-Angle Helical Bevel

Table of Contents

Falk UC Nomenclature	4
1000 to 2000 Series Comparison	5
Falk 2000 Series UC Ultramite vs. SEW Series R Interchange Data	6
Falk 2000 Series UCF Ultramite vs. SEW Series RF Interchange Data	7
Falk Low Ratio UC & UCF Drives	8
Falk UW Nomenclature	9
Right Angle Worm "UW" Interchange Accessories	10
Falk UW Ultramite vs. SEW Series S	11
Falk UW Ultramite vs. SEW Series S Accessories	12
Falk UJ Nomenclature	13
Shaft Mounted Helical "UJ" Interchange Accessories	14
Falk UJ Ultramite vs SEW Series F	15
Falk UB Nomenclature	16
Right Angle Bevel "UB" Interchange Accessories	17
Falk UB Ultramite vs. SEW Series K	18
Falk UB Ultramite vs. SEW Series K Accessories.	19
SEW Eurodrive Nomenclature	20
SEW Eurodrive Motor Data	21

Ultramite Dimensional Comparison

The dimensions and nomenclature shown are for base mounted double reduction drives. In most cases the triple reduction drives have the same external dimensions.

When this interchange was developed comparisons were made with competitive gearmotor designs. In most cases an inline gear drive model (pictured below) is available with the same footprint as its gearmotor model (pictured below).

When replacing competitor's gearmotors be aware that various motor speed and gear ratio combinations are used to arrive at the specified output RPM. Verify competitor's motor speed (motor poles) and gear drive ratio, which yields the output RPM the competitor is furnishing. Falk catalogued selections for gearmotors provide the specified output RPM using a 1750 RPM motor (4 pole) and the appropriate gear drive ratio. The competitor's nomenclature typically incorporates motor rpm or number of poles and is included for your reference. When interchanging, also note competitor's mounting position (floor mounted, wall mount, tilted, etc.).

Representative output torque comparisons are provided at 25:1 ratio and 1750 RPM input in the following dimension tables. Actual torque comparisons at other ratios should be checked using published catalogue data.

BASE MOUNTED INLINE GEAR DRIVE

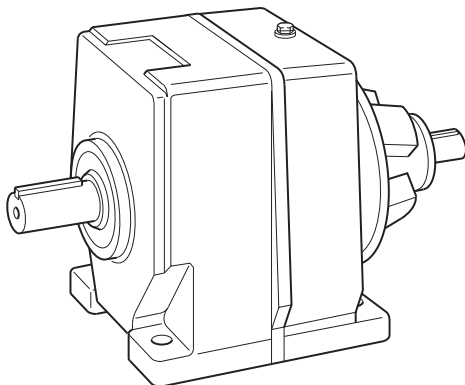

BASE MOUNTED GEARMOTOR

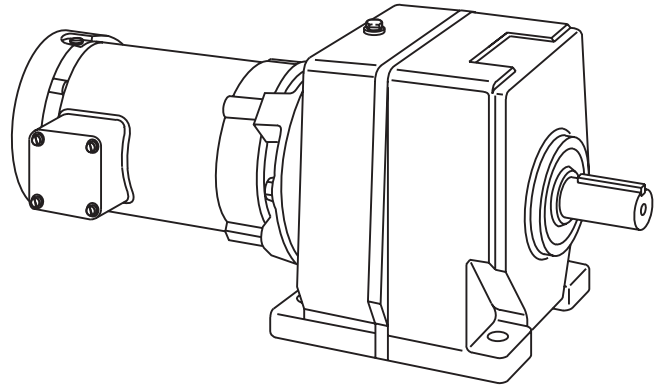

Copyright 2003, 2007. Rexnord Industries, LLC, All Rights Reserved. Litho in USA.
 Rexnord and Ultramite are registered trademarks. Falk is a trademark of Rexnord. Eurodrive and SEW are trademarks of Eurodrive.
 The contents of this selection guide are subject to change without notice or obligation. Information contained herein should be confirmed before placing orders.

UC — Drive Nomenclature

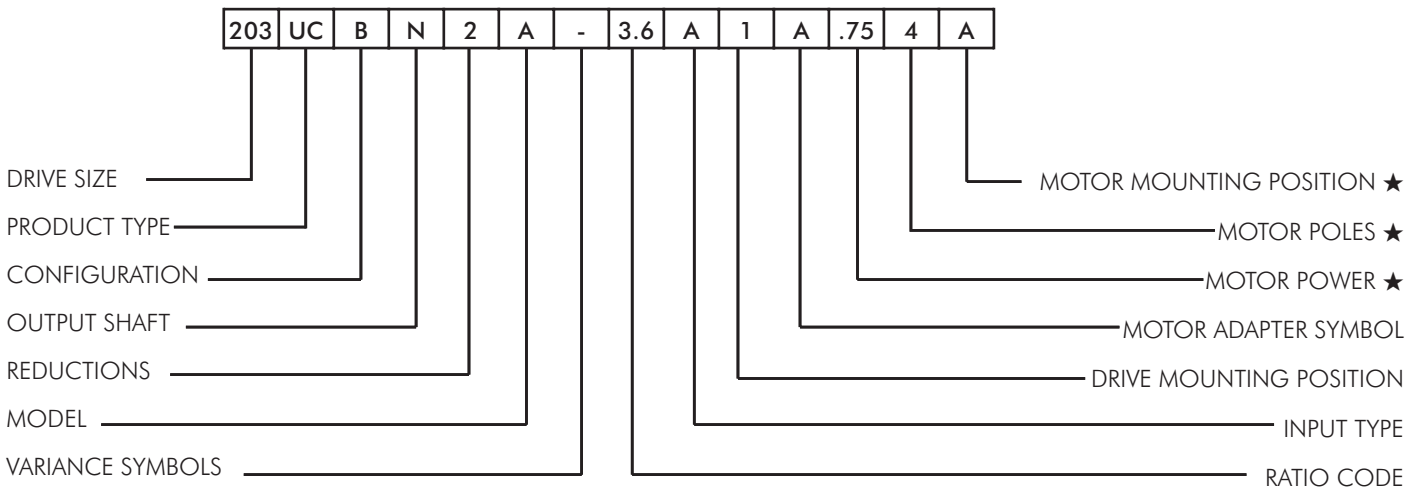

Low Ratio Drive Sizes

03, 04, 06, 07 & 08

Drive Sizes

201, 202, 203, 204, 205, 206, 207, 208, 09 & 10

Product Type

UC — Concentric Helical

Configuration

B — Base Mount
F — Flange Mount

Output Shaft

C — Metric
N — Inch

Reductions

2 — Double
3 — Triple
4 — Quadruple
5 — Quintuple

Model

A, B, C, etc.

Variance Symbol

Variance Symbol is omitted when Standard Mineral Lube and Single Seals are specified

A — Standard Mineral Lube and Double Seals
B — Synthetic Lube and Single Seals
C — Biodegradable lube and Single Seals
D — Food Compatible Lube and Single Seals
E — Synthetic Lube with Double Seals
F — Biodegradable Compatible Lube with Double Seals
G — Food compatible Lube with Double Seals
H — Backstop (Hold Back)
J — Cooling Fan - Shaft Driven
S — Multiple Variances or Special

Ratio Code, Three

Characters, Refer to Pages 12 & 13 of UC Selection Guide 281-110

1.4 thru 4.5 Low Ratio Double Reduction - Sizes 03, 04 & 06
3.6 thru 56. Double Reduction - Sizes 201-208
1.4 thru 71. Double Reduction - Sizes 09 - 10
56. thru 250 Triple Reduction - Sizes 201 - 10
225 thru 27C Quadruple Reduction C = 00 Sizes 203 - 10
27C thru 10K Quintuple Reduction K = 000 Sizes 203 - 10

Input Type

A — Gearmotor with Flange Motor Adapter - NEMA Frame
G — Gearmotor with Flange Motor Adapter - IEC Frame
N — Gear Drive with Inch Input
C — Gear Drive with Metric Input
R — Gearmotor with Flange Motor Adapter - Special Motors

Drive Mounting Position, Refer to Page 14 of UC Selection Guide 281-110

Mounting Positions 1 through 6 for UCBN
Mounting Positions 7 through 9 for UCFN

Motor Adapter Symbol, Refer to Page 16 of Selection Guide 281-110

A through W

Motor Power, Decimal Point Shown ★

Horsepower – NEMA Motor
Kilowatts – IEC Motor

Motor Poles ★

2 — Poles, 3600 rpm @ 60 Hz, or 3000 rpm @ 50 Hz
4 — Poles, 1800 rpm @ 60 Hz, or 1500 rpm @ 50 Hz
6 — Poles, 1200 rpm @ 60 Hz, or 1000 rpm @ 50 Hz
8 — Poles, 900 rpm @ 60 Hz, or 750 rpm @ 50 Hz

Motor Mounting Position, Refer to Page 14 ★ of UC Selection Guide 281-110

When Viewed from L.S. Shaft of Base Mounted Drive with Mounting Feet Down

A — Conduit Box Horizontal on Right Side, 0°
B — Conduit Box Vertical on Bottom Side, 90°
C — Conduit Box Horizontal on Left Side, 180°
D — Conduit Box Vertical on Top Side of Drive 270°

★ Motor Power, Motor Poles and Motor Mounting Position are stamped on the nameplate only if the motor is furnished & fitted by Rexnord.

1000 to 2000 Series Comparison

2000 Series vs. 1000 Series @ 25:1

Series	DRIVE SIZE	Torque	Low Speed Shaft Diameter - Inches	Base to Center - Inches	
2000	201UCBN	793	0.750	2.95	
1000	03UCBN	606	0.750	2.95	
2000	202UCBN	1416	1.000	3.54	
1000	04UCBN	1488	1.000	3.54	
2000	203UCBN	1844	1.000	3.54	NEW SIZE
1000	04UCBN	1488	1.000	3.54	
2000	204UCBN	2787	1.250	4.53	
1000	06UCBN	2620	1.250	4.53	
2000	205UCBN	3990	1.375	4.53	NEW SIZE
1000	06UCBN	3116	1.250	4.53	
2000	206UCBN	5545	1.375	5.12	NEW SIZE
1000	07UCBN	6010	1.625	5.51	
2000	207UCBN	7181	1.625	5.51	
1000	07UCBN	6010	1.625	5.51	
2000	208UCBN	13655	2.125	7.09	
1000	08UCBN	11370	2.125	7.09	
1000	09UCBN	NO CHANGE			
1000	10UCBN	NO CHANGE			

Falk 2000 Series UC Ultramite vs. SEW® Series R

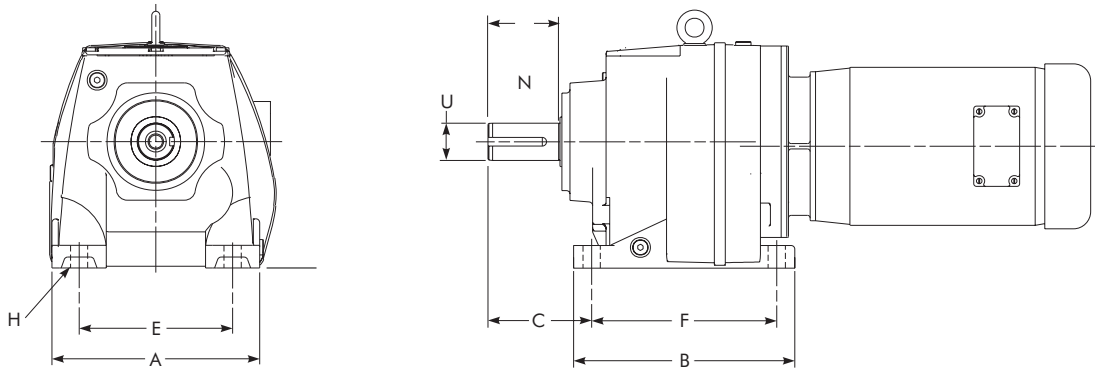

Interchange Data — Inches

SIZE	Torque ★ (lb-in.)	A	B	C	D	E	F	H	N	U	SIZE
FALK 201UC SEW R17 SEW R32	793 670 619	5.31	5.16	2.28	2.95	4.33	4.33	0.39 0.35 0.35	1.575	0.750	was 03UC
FALK 202UC SEW R27 SEW R42	1416 1178 871	5.71	5.98	2.95	3.54	4.33	5.12	0.39 0.35 0.35	1.969	1.000	was 04UC
FALK 203UC SEW R37 SEW R42	1844 1632 871	5.71	5.98	2.95	3.54	4.33	5.12	0.39 0.35 0.35	1.969	1.000	New Size
FALK 204UC SEW R47 SEW R62	2787 2590 3162	7.48	7.87	3.54	4.53	5.31	6.50	0.59 0.53 0.59	2.362	1.250	was 06UC
FALK 205UC SEW R57 SEW R62	3990 4158 3162	7.48	7.87	3.94	4.53	5.31	6.50	0.59 0.55 0.59	2.756	1.375	New Size
FALK 206UC SEW R67 SEW R62	5545 4902 3162	8.27	9.25	3.94	5.12	5.91	7.68	0.59 0.55 0.59	2.756	1.375	New Size
FALK 207UC SEW R77 SEW R72	7181 7463 3951	9.06	9.65	4.53	5.51	6.69	8.07	0.75 0.69 0.69	3.150	1.625	was 07UC
FALK 208UC SEW R87 SEW R82	13,655 13,609 7050	11.42	12.20	5.51	7.09	8.46	10.24	0.75 0.69 0.69	3.937	2.125	was 08UC
FALK 09UC SEW R97 SEW R92/3	22,163 25,396 20,720	13.39	14.37	6.30	8.86	9.84	12.20	0.91 0.87 0.87	4.72	2.375	no change
FALK 10UC SEW R107 SEWR102/3	38,152 37,800 35,100	15.75	17.32	7.28	9.84	11.42	14.57	1.06 1.02 1.02	5.51	2.875	no change

★ Torque is based on closest 25:1 ratio with 1750 rpm input.

Falk 2000 SeriesUCF Ultramite vs. SEW Series RF

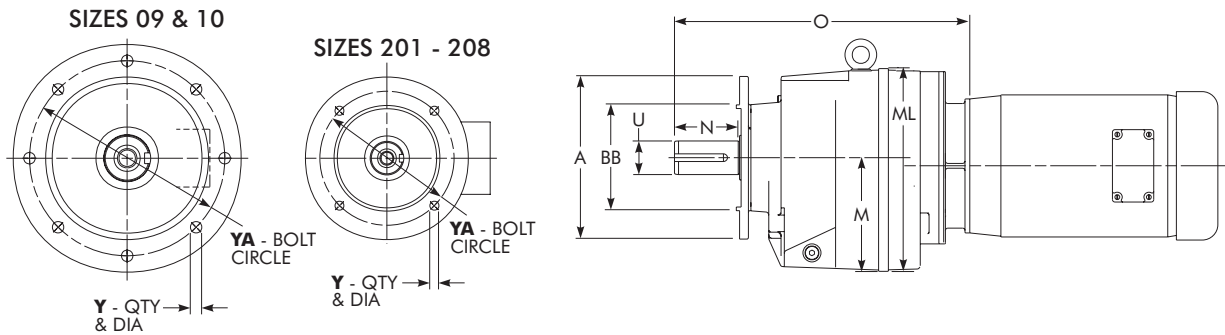

Interchange Data — Inches

SIZE	Torque ★ (lb-in.)	A ‡	BB ‡	YA ‡	Y ‡	O	M	ML	N	U	SIZE
FALK 201UCF SEW RF17 SEW RF32	793 670 619	4.72 5.51 6.30 7.87	3.15 3.74 4.33 5.12	3.94 4.53 5.12 6.50	4 x 0.35 4 x 0.35 4 x 0.35 4 x 0.43	9.02 8.46 8.69	2.99 2.99 2.87	5.90 5.31 5.47	1.575	0.750	was 03UCF
FALK 202UCF SEW RF27 SEW RF42	1416 1178 871	4.72 5.51 6.30 7.87	3.15 3.74 4.33 5.12	3.94 4.53 5.12 6.50	4 x 0.26 4 x 0.35 4 x 0.35 4 x 0.43	9.92 7.83 7.95	3.58 3.62 3.54	7.12 5.87 6.46	1.969	1.000	was 04UCF
FALK 203UCF SEW RF37 SEW RF42	1844 1632 871	4.72 5.51 6.30 7.87	3.15 3.74 4.33 5.12	3.94 4.53 5.12 6.50	4 x 0.26 4 x 0.35 4 x 0.35 4 x 0.43	9.92 8.05 7.95	3.58 3.70 3.54	7.12 6.10 6.46	1.969	1.000	New Size
FALK 204UCF SEW RF47 SEW RF62	2787 2590 3162	5.51 6.30 7.87 9.84	3.74 4.33 5.12 7.09	4.53 5.12 6.50 8.46	4 x 0.35 4 x 0.35 4 x 0.43 4 x 0.53	11.50 9.25 9.80	4.53 4.65 4.65	8.19 7.48 8.23	2.362	1.250	was 06UCF
FALK 205UCF SEW RF57 SEW RF62	3990 4158 3162	5.51 6.30 7.87 9.84	3.74 4.33 5.12 7.09	4.53 5.12 6.50 8.46	4 x 0.35 4 x 0.35 4 x 0.43 4 x 0.53	11.89 10.12 9.80	4.53 4.76 4.65	8.19 7.60 8.23	2.756	1.375	New Size
FALK 206UCF SEW RF67 SEW RF62	5545 4902 3162	7.87 9.84 11.81	5.12 7.09 9.06	6.50 8.46 10.43	4 x 0.43 4 x 0.53 4 x 0.53	12.72 11.02 9.80	5.12 5.28 4.65	8.43 8.50 8.23	2.756	1.375	New Size
FALK 207UCF SEW RF77 SEW RF72	7181 7463 3951	7.87 9.84 11.81	5.12 7.09 9.06	6.50 8.46 10.43	4 x 0.43 4 x 0.53 4 x 0.53	14.21 11.81 11.81	5.51 5.67 5.67	9.84 9.13 9.96	3.150	1.625	was 07UCF
FALK 208UCF SEW RF87 SEW RF82	13,655 13,609 7050	11.81 13.78	9.06 9.84	10.43 11.81	4 x 0.53 4 x 0.69	17.05 14.65 15.55	7.17 7.24 7.24	12.29 11.77 12.52	3.937	2.125	was 08UCF
FALK 09UCF SEW RF97 SEW RF92/3	22,163 25,396 20,720	17.72	13.78	15.75	8 x 0.71	20.83 17.32 17.32	9.06 9.06 8.86	14.98 14.72 15.20	4.72	2.375	no change
FALK 10UCF SEW RF107 SEW RF102/3	38,152 37,800 35,100	17.72	13.78	15.75	8 x 0.71	23.83 19.49 20.16	10.24 10.24 9.61	17.57 16.26 16.97	5.51	2.875	no change

★ Torque is based on closest cataloged 25:1 ratio with 1750 rpm input.

‡ All the flanges are identical; shown are the optional offerings and sizes; **BOLD** are the standard offerings.

Low Ratio Falk UC Ultramite vs. SEW® Series R

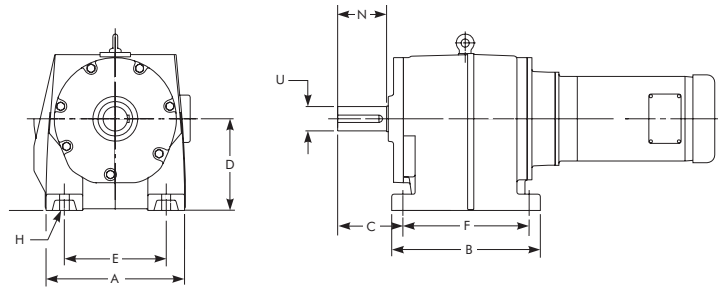

Interchange Data — Inches

SIZE	Torque ★ (lb-in.)	A	B	C	D	E	F	H	N	U
FALK03UC SEW R17 SEWR32	606 670 619	5.31	4.33 5.16 4.33	2.28	2.95	4.33	3.35 4.33 3.35	0.39 0.35 0.35	1.57	0.7500
FALK 04UC SEW R37 SEW R40 SEW R27	1488 1632 871 1178	5.71	6.30 6.30 6.30 5.98	2.95	3.54	4.33	5.12	0.35	1.97	1.000
FALK 06UC SEW R67 SEW R57 SEW R47 SEW R60/3	3116 4902 4158 2590 2126	7.48	7.87 9.25 7.87 7.68 7.87	3.54 3.94 3.94 3.54 3.54	4.53 5.12 4.53 4.53 4.53	5.31 5.91 5.31 5.31 5.31	6.50 7.68 6.50 6.50 6.50	0.59 0.55 0.55 0.53 0.59	2.36 2.76 2.76 2.36 2.36	1.2500 1.3750 1.3750 1.2500 1.2500
FALK 07UC SEW R77 SEW R67 SEW R72/3	6010 7463 4902 3551	9.06	9.65 9.65 9.25 9.65	4.53 4.53 3.94 4.53	5.51 5.51 5.12 5.51	6.69 6.69 5.91 6.69	8.07 8.07 7.68 8.07	0.75 0.69 0.55 0.69	3.15 3.15 2.76 3.15	1.6250 1.6250 1.3750 1.6250
FALK 08UC SEW R87 SEW R82/3	11,370 13,609 7050	11.42	12.20	5.51	7.09	8.46	10.24	0.75 0.69 0.69	3.94	2.1250

★ Torque is based on closest cataloged 25:1 ratio with 1750 rpm input.

Low Ratio Falk UCF Ultramite vs. SEW Series RF

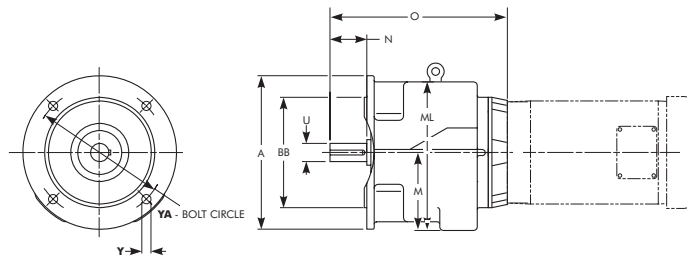

Interchange Data — Inches

SIZE	Torque ★ (lb-in.)	A †	BB †	O	M	ML	YA †	Y †	N	U
FALK 03UCF SEW RF17 SEW RF32	606 670 619	6.30 5.51 4.72	4.33 3.74 3.15	9.02 8.46 8.69	3.15 2.99 2.87	5.91 5.31 5.47	5.12 4.53 3.94	0.39 0.35 0.26	1.57	0.7500
FALK 04UCF SEW RF37 SEW RF40 SEW RF27	1488 1632 871 1178	7.87 7.87 7.87 6.30	5.12 5.12 5.12 4.33	9.92 8.05 7.95 7.83	3.74 3.70 3.54 3.62	7.20 6.10 6.46 5.87	6.50 6.50 6.50 5.12	0.47 0.43 0.43 0.35	1.97	1.0000
FALK 06UCF SEW RF67 SEW RF57 SEW RF47 SEW RF60	3116 4902 4158 2590 2126	9.84 9.84 9.84 7.87 9.84	7.09 7.09 7.09 5.12 7.09	11.50 11.02 10.12 9.25 9.80	4.45 5.28 4.76 4.65 4.65	8.98 8.50 7.60 7.48 8.23	8.46 8.46 8.46 6.50 8.46	0.59 0.53 0.53 0.43 0.55	2.36 2.76 2.76 2.36 2.36	1.2500 1.3750 1.3750 1.2500 1.2500
FALK 07UCF SEW RF77 SEW RF67 SEW RF72/3	6010 7463 4902 3551	11.81 11.81 9.84 11.81	9.06 9.06 7.09 9.06	14.29 11.81 11.02 11.81	5.43 5.67 5.28 5.67	10.86 9.13 8.50 9.96	10.43 10.43 8.46 10.43	0.59 0.53 0.53 0.55	3.15 3.15 2.76 3.15	1.6250 1.6250 1.3750 1.6250
FALK 08UCF SEW RF87 SEW RF82/3	11,370 13,609 7050	13.78	9.84	17.68 14.65 15.55	7.36 7.24 7.24	12.29 11.77 12.52	11.81	0.71 0.69 0.71	3.94	2.1250

★ Torque is based on closest cataloged 25:1 ratio with 1750 rpm input.

† SEW offers optional flange sizes which will change the "A", "BB", "YA", and "Y" dimensions.

UW — Drive Nomenclature

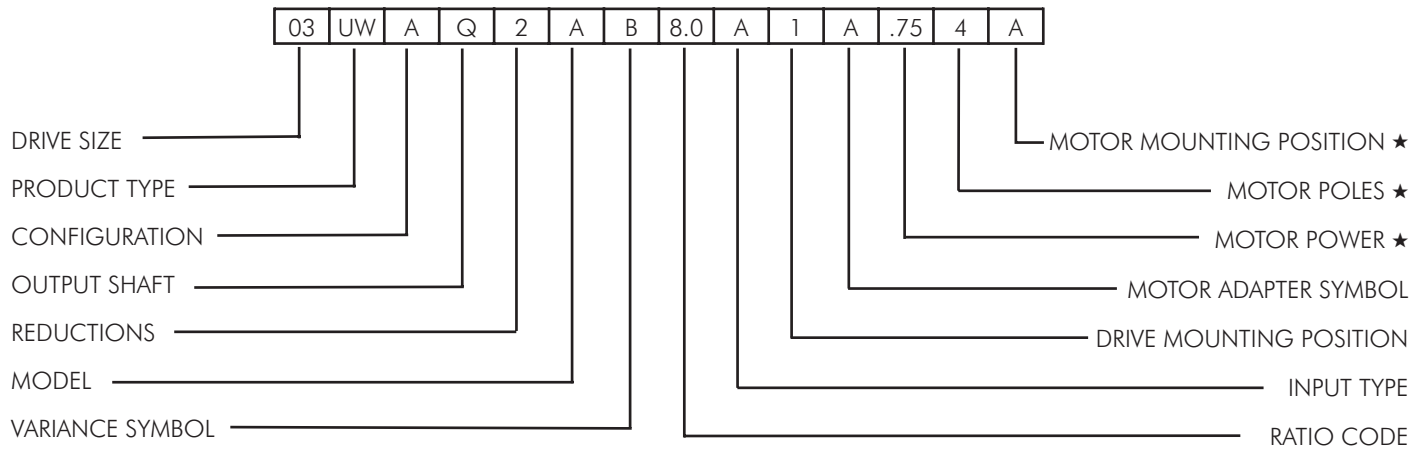

Drive Sizes

03, 04, 05, 06, 07, 08, 09 & 10

Product Type

UW — Right Angle Helical Worm

Configuration

- A — Basic Drive (Sizes 03-06) Without Feet
- B — Base Mounted Feet (07-10) Integral Feet
- C — Base Mounted Feet (03-06)
- D — End Mounted Feet
- E — Top Mounted Feet
- F — Standard Output Flange
- G — Reduced Diameter Output Flange (03 Only)
- J — With Torque Arm
- K — With Banjo Torque Arm
- X — Standard Output Flange w/Vertical Drywell (07-10)

Output Shaft

- Q — Inch Hollow
- B — Inch Single Ended, L.H. ‡
- C — Inch Single Ended, R.H. ‡
- D — Inch Double Ended
- E — Straight Metric Hollow
- F — Metric Single Ended, L.H. ‡
- G — Metric Single Ended, R.H. ‡
- H — Metric Double Ended
- J — Taper Hollow
- K — Taper Inch Single Ended, L.H. ‡
- L — Taper Metric Single Ended, R.H. ‡
- M — TA Taper Metric bushing (Bore Diameter)
- N — TA Taper Inch Bushing (Bore Diameter)
- P — CEMA Seal Housing & Drive Shaft (DS Diameters)

Reductions

- 2 — Double
- 3 — Triple
- 4 — Quadruple
- 5 — Quintuple

Model

A, B, C, etc.

Variance Symbol

Variance Symbol B is inserted when Standard Synthetic Lube and Single Seals are specified

- A — Standard Mineral Lube and Double Seals
- B — Standard Synthetic Lube and Single Seals

‡ When viewed from L.S. End.

- C — Biodegradeable Lube and Single Seals
- D — Food Compatible Lube and Single Seals
- E — Synthetic Lube with Double Seals
- F — Biodegradeable Compatible Lube with Double Seals
- G — Food Compatible Lube with Double Seals
- H — Backstop (Hold Back)
- J — Cooling Fan - Shaft Driven
- S — Multiple Variances or Special

Ratio Code, Three Characters, Refer to Pages 14 & 15 of UW Selection Guide 281-210

8.0 through 250 Double Reduction

100 through 900 Triple Reduction

280 through 16K Quadruple Reduction C = 00

18K through 60K Quintuple Reduction K = 000

Input Type

- A — Gearmotor with Flange Motor Adapter - NEMA Frame
- G — Gearmotor with Flange Motor Adapter - IEC Frame
- N — Gear Drive with Inch Input
- C — Gear Drive with Metric Input
- R — Gearmotor with Flange Motor Adapter - Special Motors

Drive Mounting Position, Refer to Page 16 of UW Selection Guide 281-210

Mounting Positions 1 through 6

Motor Adapter Symbol, Refer to Page 17 & 18 of UW Selection Guide 281-210

A through W

Motor Power, Decimal Point Shown ★

Horsepower — NEMA Motor Kilowatts — IEC Motor

Motor Poles ★

- 2 — Poles, 3600 rpm @ 60 Hz, or 3000 rpm @ 50 Hz
- 4 — Poles, 1800 rpm @ 60 Hz, or 1500 rpm @ 50 Hz
- 6 — Poles, 1200 rpm @ 60 Hz, or 1000 rpm @ 50 Hz
- 8 — Poles, 900 rpm @ 60 Hz, or 750 rpm @ 50 Hz

Motor Mounting Position, Refer to Page 16 ★ of UW Selection Guide 281-210

When Viewed from L.S. End of Base Mounted Foot Drive.

- A — Conduit Box Horizontal on Right Side, 0°
- B — Conduit Box Vertical on Bottom Side, 90°
- C — Conduit Box Horizontal on Left Side, 180°
- D — Conduit Box Vertical on Top Side of Drive 270°

Motor Power, Motor Poles and Motor Mounting Position are stamped on the nameplate only if the motor is furnished & fitted by Rexnord.

Right Angle Worm "UW" Interchange Accessories

- S** = Integral Foot & Solid O/P Shaft **UWAQ** Basic + Foot Kit + O/P Shaft
SF = Integral Foot, Solid O/P Shaft & O/P Flange **UWAQ** Basic + O/P Flange + O/P Shaft
SA = Integral Foot & Hollow O/P Shaft **UWAQ** Basic + Foot Kit
SAF = Integral Foot, Hollow O/P Shaft & O/P Flange **UWAQ** Basic + O/P Flange Kit
SH = Integral Foot with Shrink Disc & Hollow Shaft. **UWAJ** Basic + TA Taper Bushing

EXAMPLE:

SF77 = **07UWFB** made from **07UWBQ** Basic Unit + "**F**" O/P Flange + "**B**" O/P Shaft left hand mount.

Accessories

BASIC DRIVE FALK ULTRAMITE	SEW	Basic Feet ★	O/P Flange	O/P Shaft	TA Bushing	Description	Double O/P Shaft	Banjo Torque Arm
		"C"	"F"	"B" = LH "C" = RH	"N"	Nomenclature	"D" = Double Ended	"K"
03UWAQ	S37	X		X		UWCB	1940538	1940570
03UWAQ	SF37		X	X		UWFB	-	-
03UWAQ	SA37					UWAQ	-	-
03UWAQ	SAF37		X			UWFQ	-	-
04UWAQ	S47	X		X		UWCB	1940539	1940571
04UWAQ	SF47		X	X		UWFB	-	-
04UWAQ	SA47					UWAQ	-	-
04UWAQ	SAF47		X			UWFQ	-	-
05UWAQ	S57	X		X		UWCB	1940540	1940572
05UWAQ	SF57		X	X		UWFB	-	-
05UWAQ	SA57					UWAQ	-	-
05UWAQ	SAF57		X			UWFQ	-	-
05UWAJ	SH57				X	UWAN	-	-
06UWAQ	S67	X		X		UWCB	1940541	1940573
06UWAQ	SF67		X	X		UWFB	-	-
06UWAQ	SA67					UWAQ	-	-
06UWAQ	SAF67		X			UWFQ	-	-
06UWAJ	SH67				X	UWAN	-	-
07UWBQ	S77			X		UWBB	1940542	1940574
07UWBQ	SF77		X	X		UWFB	-	-
07UWBQ	SA77					UWBQ	-	-
07UWBQ	SAF77		X			UWFQ	-	-
07UWBJ	SH77				X	UWAN	-	-
08UWBQ	S87			X		UWBB	1940543	1940575
08UWBQ	SF87		X	X		UWFB	-	-
08UWBQ	SA87					UWBQ	-	-
08UWBQ	SAF87		X			UWFQ	-	-
08UWBJ	SH87				X	UWAN	-	-
09UWBQ	S97			X		UWBB	1940544	1940576
09UWBQ	SF97		X	X		UWFB	-	-
09UWBQ	SA97					UWBQ	-	-
09UWBQ	SAF97		X			UWFQ	-	-
09UWBJ	SH97				X	UWAN	-	-
10UWBQ	S107			X		UWBB	1940778	1940782
10UWBQ	SF107		X	X		UWFB	-	-
10UWBQ	SA107					UWBQ	-	-
10UWBQ	SAF107		X			UWFQ	-	-
10UWBJ	SH107				X	UWAN	-	-

★ Foot kit is an accessory on Sizes 03-06 and integral to housing on Sizes 07-10.

Falk UW Ultramite vs. SEW Series S

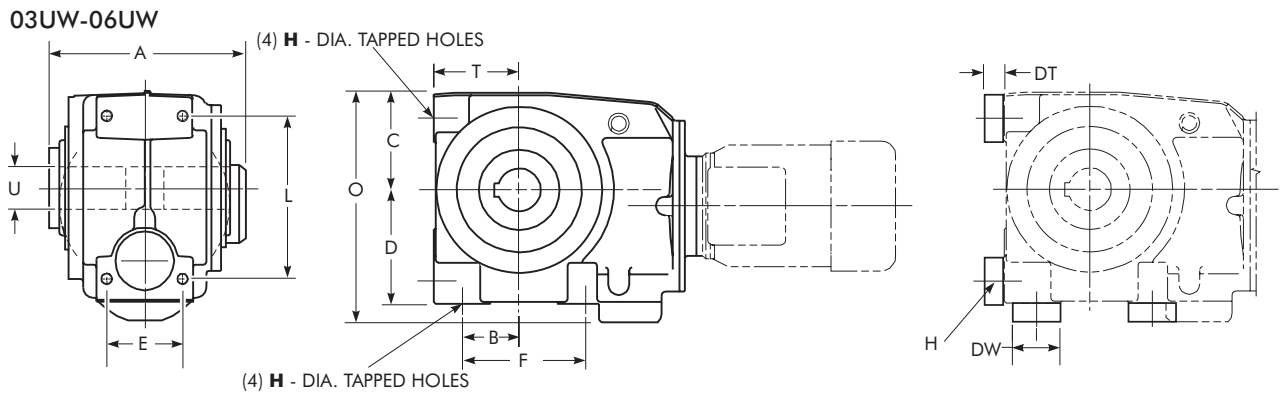

Interchange Data — Inches

SIZE	Torque ★ (lb-in.)	A	B	C	D	DT	DW	E	F	H	O	L	T	U
FALK 03UW	843	4.64		2.68	2.80	0.35	0.98				5.81		2.13	
SEW S32	565	4.72	1.38	2.48	3.15	NA	NA	3.54	2.48	0.35	5.63	3.14	2.48	0.7500
SEW S37	690	4.72		2.48	3.15	NA	NA				5.63		2.48	
FALK 04UW	1383	5.14		2.95	3.39	0.55	1.38				6.61	4.65	2.52	
SEW S42	1068	5.51	1.38	2.48	3.94	NA	NA	3.94	3.15	0.43	6.42	3.15	2.95	1.2500
SEW S47	1292	4.72		2.56	3.94	NA	NA				6.50	3.15	2.95	
FALK 05UW	3078	5.52		3.46	3.78	0.63	1.57				7.87	5.59	2.68	
SEW S52	1480	5.71	1.77	3.07	4.41	NA	NA	4.34	3.94	0.43	7.48	3.94	3.15	1.3750
SEW S57	2320	5.91		3.03	4.41	NA	NA				7.44	3.94	3.15	
FALK 06UW	5185	7.09	2.20	4.06	4.72	0.79	1.97		4.80	0.55	9.55	6.77	3.54	
SEW S62	3140	7.09	2.36	3.58	5.51	NA	NA	5.12	5.12	0.55	9.09	5.12	3.15	1.5000
SEW S67	4032	6.61	2.36	3.78	5.51	NA	NA		5.12	0.53	9.29	5.12	3.15	

07UW-10UW

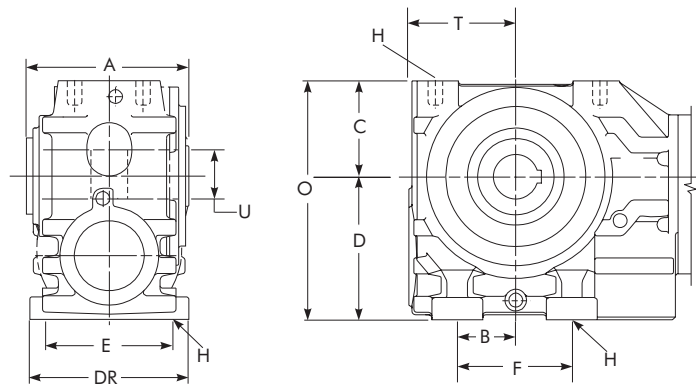

Interchange Data — Inches

SIZE	Torque ★ (lb-in.)	A	B	C	D	DR	E	F	H	O	T	U
FALK 07UW	7049	8.58		4.80						11.90	5.63	
SEW S72	6190	8.58	2.95	4.37	7.09	7.28	5.90	5.31	0.71	11.46	4.92	2.000
SEW S77	8450	8.27		4.76					0.69	11.85	4.92	
FALK 08UW	13,712	11.00		5.91						14.81	6.61	
SEW S82	10,200	9.84	3.62	5.79	8.90	9.84	7.88	7.09	0.87	14.65	5.91	2.375
SEW S87	11,167	9.84		5.63						14.49	5.91	
FALK 09UW	25,275	13.26		6.97		12.00				17.97	7.68	
SEW S92	19,200	11.81	4.53	7.01	11.00	11.81	9.84	9.25	1.02	18.03	7.09	2.750
SEW S97	23,900	11.42		6.89		11.81				17.91	7.09	
FALK 10UW	45,920	15.28	6.69	9.06	13.20	14.18	11.82	12.20	1.02	22.26	9.25	3.250

★ Torque is based on closest cataloged 25:1 ratio with 1750 rpm input.

Falk UW Ultramite vs. SEW Series S Accessories

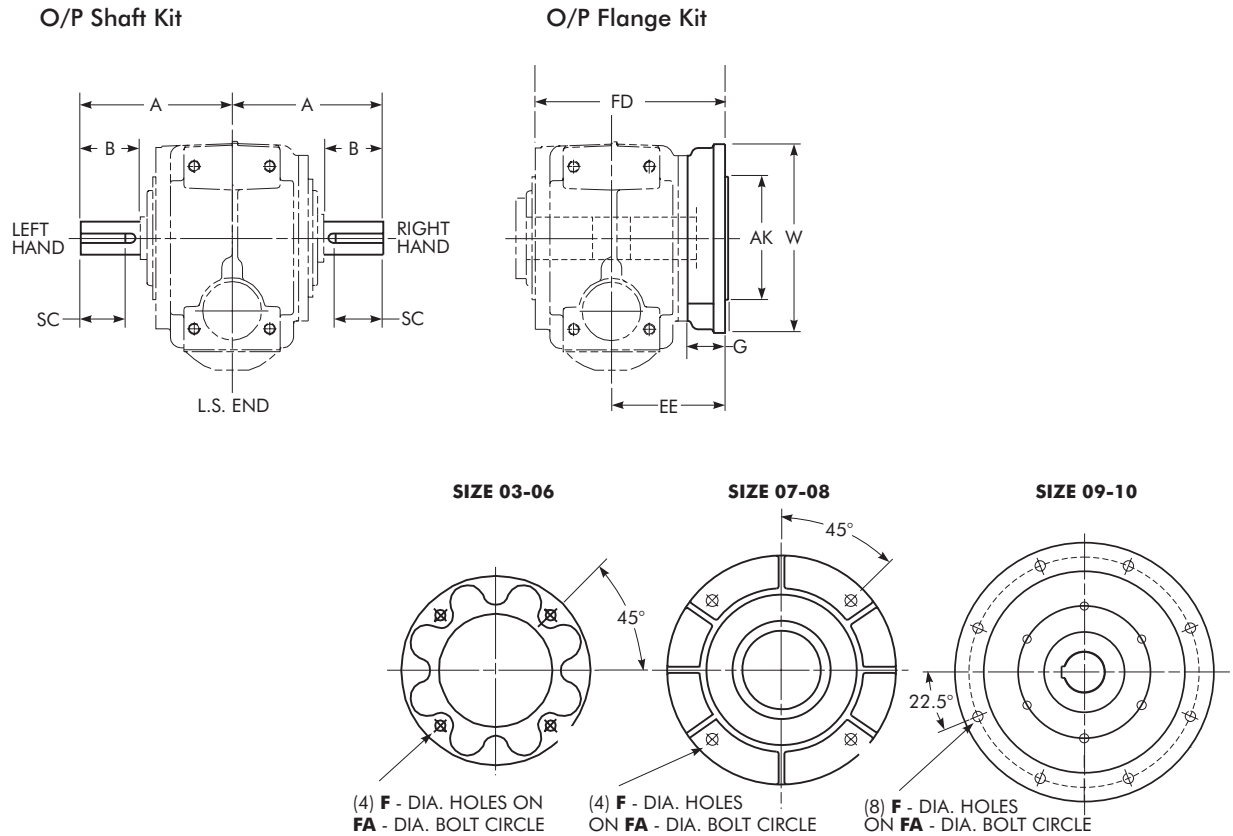

Accessories Interchange Data — Inches

SIZE	A	B	Single Ext O/P Shaft	Double Ext O/P Shaft	SC	FD	EE	G	AK	W	FA	F
FALK 03UW SEW S32 SEW S37	3.94	1.38 1.57 1.57	0.7500	0.7500	1.1875 1.0625 1.0625	5.67 5.57 5.57	3.31	0.39	4.33	7.09 6.30 6.30	5.12	0.35
FALK 04UW SEW S42 SEW S47	4.53	1.81 1.97 1.97	1.0000	1.0000	1.5625 1.9375 1.9375	7.48 6.50 6.77	4.53 3.71 3.94	0.47	5.12	7.87	5.12	0.43
FALK 05UW SEW S52 SEW S57	5.28	2.36	1.2500	1.2500	2.0000 1.6875 1.6875	7.44 7.36 7.36	4.17 4.17 4.21	0.63 0.63 0.59	7.09	9.84	6.50	0.55 0.55 0.53
FALK 06UW SEW S62 SEW S67	6.30 6.34 6.73	2.48 2.76 2.76	1.3750	1.3750	2.1872 1.8125 1.8125	8.66 7.94 7.86	5.12 4.44 4.75	0.63 0.59 0.59	7.09	9.84	6.50	0.55 0.55 0.53
FALK 07UW SEW S72 SEW S77	7.68 7.72 8.11	2.99 3.54 3.54	1.7500	1.7500	2.6875 2.7500 2.7500	9.72 9.68 9.57	5.59	0.71 0.59 0.63	9.06 7.09 9.06	11.81 9.84 11.81	8.46	0.55 0.55 0.53
FALK 08UW SEW S82 SEW S87	10.04	4.72	2.3750	2.3125 2.3750 2.3750	4.1875 3.2500 3.6250	11.22 10.51 11.34	6.50 5.59 5.91	0.71 0.79 0.71	9.84	13.78	11.81	0.71 0.71 0.69
FALK 09UW SEW S92 SEW S97	11.61	5.31 5.51 5.51	2.8750	2.6875 2.8750 2.8750	4.6875 3.5000 4.1250	13.82 13.47 14.29	7.92 7.56 7.56	0.79 0.87 0.87	13.78	17.72	15.75	0.71 0.71 0.69
FALK 10UW	14.41	6.69	3.6250	3.1875	6.3281	16.16	9.27	0.87	13.78	17.72	15.75	0.71

UJ – Drive Nomenclature

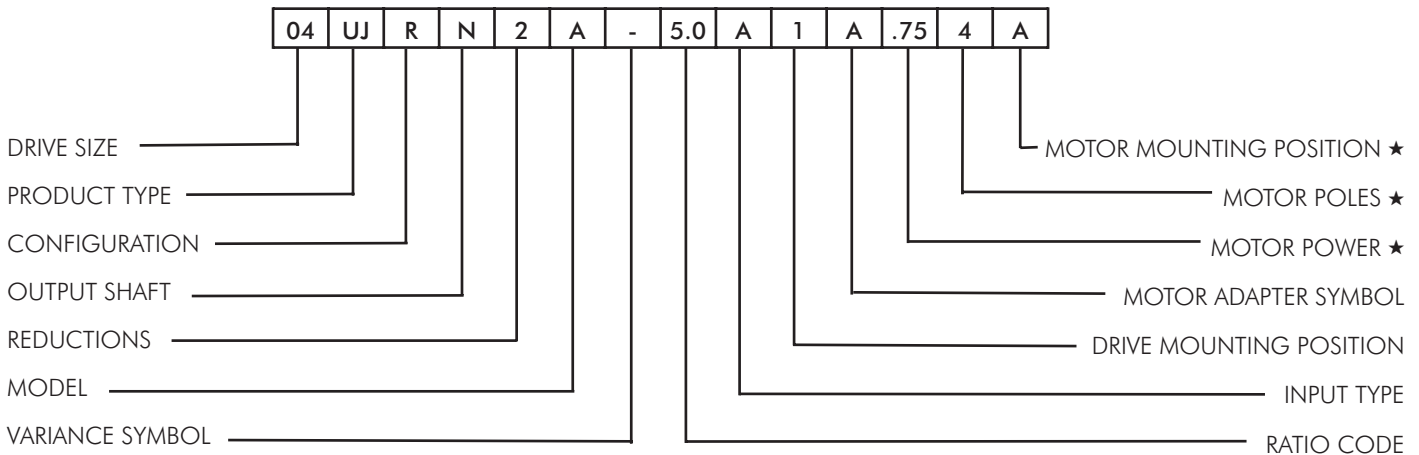

Drive Sizes

04, 06, 07, 08, 09 & 10

Product Type

UJ — Shaft Mounted Offset Helical

Configuration

- A — Basic Drive(No Feet, No Torque Arm)
- C — Base Mounted Feet(Looking At LSS Bushing End)
- D — Side Mounted Feet Left(Looking At LSS Bushing End)
- E — Side Mounted Feet Right(Looking At LSS Bushing End)
- F — Standard Output Flange
- R — With Torque Arm

Output Shaft

- Q — Straight Inch Hollow
- E — Straight Metric Hollow
- J — Tapered Hollow
- M — TA Taper Metric Bushing(Bore Diameter)
- N — TA Taper Inch Bushing(Bore Diameter)
- P — CEMA Seal Housing and Drive Shaft(D.S. Diameter)
- K — Inch Single Ended
- L — Metric Single Ended

Reductions

- 2 — Double
- 3 — Triple

Model

A, B, C, etc.

Variance Symbol

Variance Symbol is omitted when Standard Mineral Lube and Single Seals are specified

- A — Standard Mineral Lube and Double Seals
- B — Synthetic Lube and Single Seals
- C — Biodegradeable Lube and Single Seals
- D — Food Compatible Lube and Single Seals
- E — Synthetic Lube with Double Seals
- F — Biodegradeable Compatible Lube With double Seals
- G — Food Compatible Lube With Double Seals
- S — Special
- H — Backstop (Hold Back)
- J — Cooling Fan - Shaft Driven
- S — Multiple Variances or Special

Ratio Code, Three Characters, Refer to Page 12 of UJ Selection Guide 281-310

- 5.0 through 100 Double Reduction
- 83. through 355 Triple Reduction
- 360 through 56C Quadruple Reduction
- C = 00
- 45C through 20K Quintuple Reduction
- K = 000

Input Type

- A — Gearmotor with Flange Motor Adapter - NEMA Frame
- G — Gearmotor with Flange Motor Adapter - IEC Frame
- N — Gear Drive with Inch Input
- C — Gear Drive with Metric Input
- R — Gearmotor with Flange Motor Adapter - Special Motors

Drive Mounting Position, Refer to Page 13 of UJ Selection Guide 281-310

Mounting Positions 1 through 6

Motor Adapter Symbol, Refer to Page 14 of UJ Selection Guide 281-310

A through W

Motor Power, Decimal Point Shown ★

Horsepower – NEMA Motor
Kilowatts – IEC Motor

Motor Poles ★

- 2 — Poles, 3600 rpm @ 60 Hz, or 3000 rpm @ 50 Hz
- 4 — Poles, 1800 rpm @ 60 Hz, or 1500 rpm @ 50 Hz
- 6 — Poles, 1200 rpm @ 60 Hz, or 1000 rpm @ 50 Hz
- 8 — Poles, 900 rpm @ 60 Hz, or 750 rpm @ 50 Hz

Motor Mounting Position, Refer to Page 13 ★ of UJ Selection Guide 281-310

When Viewed from L.S. Shaft of Base Mounted Drive with Mounting Feet Down

- A — Conduit Box Horizontal on Right Side, 0°
- B — Conduit Box Vertical on Bottom Side, 90°
- C — Conduit Box Horizontal on Left Side, 180°
- D — Conduit Box Vertical on Top Side of Drive 270°

★ Motor Power, Motor Poles and Motor Mounting Position are stamped on the nameplate only if the motor is furnished & fitted by Rexnord.

Shaft Mounted Helical "UJ" Interchange Accessories

F = Integral Side Rails & Solid O/P Shaft. **UJAJ** Basic + Side Feet + O/P Shaft

FF = Integral Side Rails, Solid O/P Shaft & O/P Flange. **UJAJ** Basic + O/P Flange + O/P Shaft

FA = Integral Side Rails & Hollow O/P Shaft **UJAJ** Basic + TA Taper Bushing

FAF = Integral Side Rails, Hollow O/P Shaft & O/P Flange . . . **UJAJ** Basic + O/P Flange + TA Taper Bushing

EXAMPLE:

FA87 = **08UJAN** made from **08UJAJ** Basic Unit + "N" TA Taper bushing

Accessories

Basic Drive FALK ULTRAMITE	SEW	Sode Feet "D" = LH "E" = RH	O/P Flange "F"	O/P Shaft "K"	TA Bushing "N"	Final Nomenclature	Additional Accessories	
							Seal Housing "p"	Torque Arm "R"
04UJAJ	F47	X		X		UJDK	4761820	4761825
04UJAJ	FF47		X	X		UJFK	-	-
04UJAJ	FA47				X	UJAN	-	-
04UJAJ	FAF47		X		X	UJFN	-	-
06UJAJ	F67	X		X		UJDK	4761821	4761826
06UJAJ	FF67		X	X		UJFK	-	-
06UJAJ	FA67				X	UJAN	-	-
06UJAJ	FAF67		X		X	UJFN	-	-
07UJAJ	F77	X		X		UJDK	4761822	4761827
07UJAJ	FF77		X	X		UJFK	-	-
07UJAJ	FA77				X	UJAN	-	-
07UJAJ	FAF77		X		X	UJFN	-	-
08UJAJ	F87	X		X		UJDK	4761823	4761828
08UJAJ	FF87		X	X		UJFK	-	-
08UJAJ	FA87				X	UJAN	-	-
08UJAJ	FAF87		X		X	UJFN	-	-
09UJAJ	F97	X		X		UJDK	4761824	4761829
09UJAJ	FF97		X	X		UJFK	-	-
09UJAJ	FA97				X	UJAN	-	-
09UJAJ	FAF97		X		X	UJFN	-	-
10UJAJ	FA107				X	UJAN	-	-
10UJAJ	FAF107		X		X	UJFN	-	-

Falk UJ Ultramite vs. SEW Series F

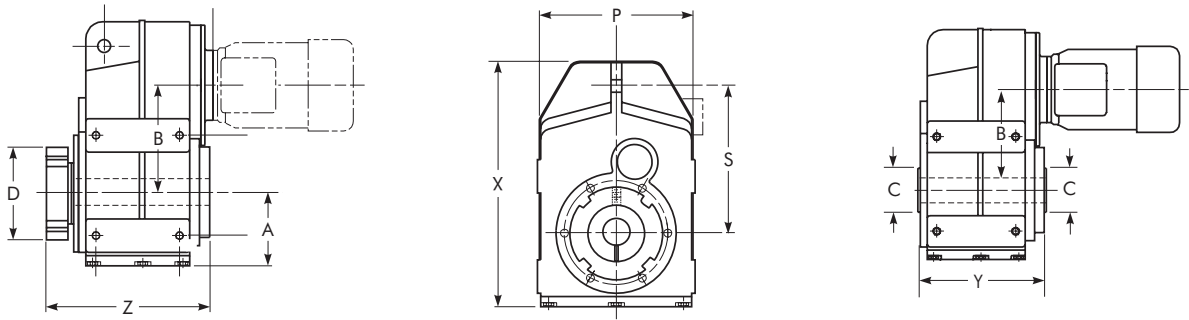

Interchange Data — Inches

SIZE	Torque ★ (lb - in.)	A	B	X	S	P	With Taper Bore		With Straight Bore	
							Z	D	Y	C
FALK 04UJ SEW FA40 SEW FA47	3240 2634 3203	3.35 3.03	4.72 5.14 5.04	11.10 11.22 10.59	6.69	6.54 6.77 7.28	8.27 NA NA	3.31 NA NA	5.91 5.63 6.00	1.250" 1.375"
FALK 06UJ SEW FA60 SEW FA67	6710 5724 7236	4.33 3.98 3.82	6.30 6.34 6.28	14.45 13.82 13.50	8.58	8.90 8.35 8.54	10.18 NA NA	4.06 NA NA	7.91 7.20 7.20	1.500"
FALK 07UJ SEW FA70 SEW FA77	11,790 10,275 13,160	5.28 4.88 4.76	7.87 8.21 7.87	17.68 17.40 16.77	10.94	10.47 10.24 10.83	11.82 NA NA	4.31 NA NA	9.35 8.69 8.39	2.000"
FALK 08UJ SEW FA80 SEW FA87	20,330 17,875 22,260	5.83 5.94 5.98	8.90 10.06 9.71	20.71 21.26 20.91	13.62	12.60 12.40 13.23	12.67 NA NA	4.81 NA NA	10.43 9.57 9.57	2.375"
FALK 09UJ SEW FA90 SEW FA97	35,500 28,545 37,950	6.89 7.17 7.01	10.79 11.44 11.22	24.09 24.72 24.53	15.55	15.12 14.96 15.94	15.77 NA NA	5.68 NA NA	12.99 11.97 11.97	2.750"
FALK 10UJ SEW FA100 SEW FA107	47,580 14,009 67,007	8.50 8.86 7.87	13.07 14.09 13.09	29.45 30.04 28.23	19.09	17.87 18.27 17.72	17.33 NA NA	6.06 NA NA	1457 13.94 13.94	3.250"

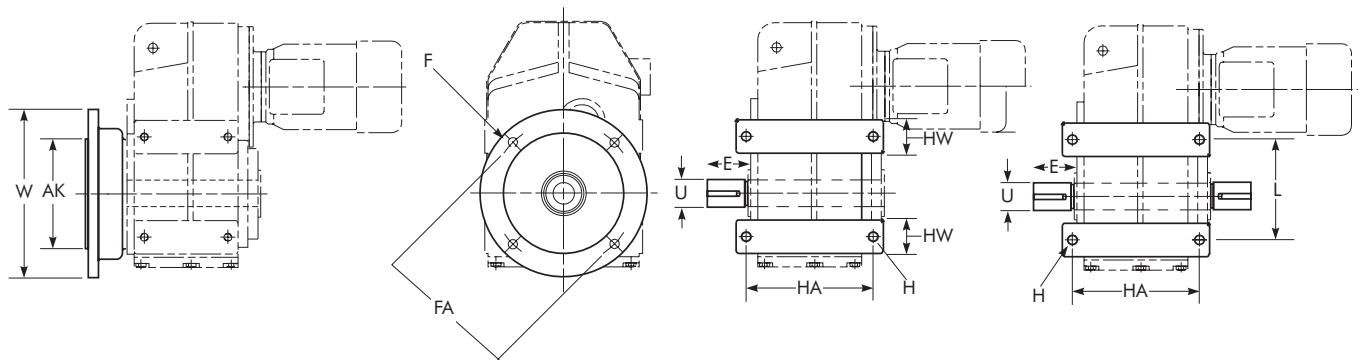

SIZE	ZY	AK	W	FA	F	E	U	HA	HW	H	L
FALK 04UJ SEW FA40/47	7.44 6.77	5.12	7.87	6.50	0.43	1.81 2.10	1.000" 1.250"	3.54 3.66	1.38 0.79	0.68 0.59	4.33 5.71
FALK 06UJ SEW FA60/67	9.35 8.07	7.09	9.84	8.46	0.55	2.56 2.77	1.375" 1.625"	4.92 4.41	1.97 0.98	0.79 0.67	5.91 7.48
FALK 07UJ SEW FA70 SEW FA77	10.73 9.84 9.84	7.09 9.05	9.84 11.81	8.46 10.43	0.55 0.53	3.19 3.30	1.750" 2.000"	5.91 5.51 5.51	2.36 1.38 1.38	0.98 1.02	7.78 9.45 9.45
FALK 08UJ SEW FA80/87	12.17 10.71	9.84	13.78	11.81	0.71	4.49 4.21	2.375"	6.69 6.50	2.36 1.58	0.94 1.02	7.88 12.20
FALK 09UJ SEW FA90/97	14.80 13.58	13.78	17.72	15.75	0.71	5.32 5.51	2.875"	8.46 8.07	2.36 1.97	0.94 1.10	13.51 13.78
FALK 10UJ SEW 100/107	16.71 15.51	13.78	17.72	15.75	0.71	6.77 6.69	3.625"	9.84 8.66	2.95 2.36	1.06 1.42	19.63 15.75

★ Torque is based on closest cataloged 25:1 ratio with 1750 rpm input.

UB – Drive Nomenclature

Drive Sizes

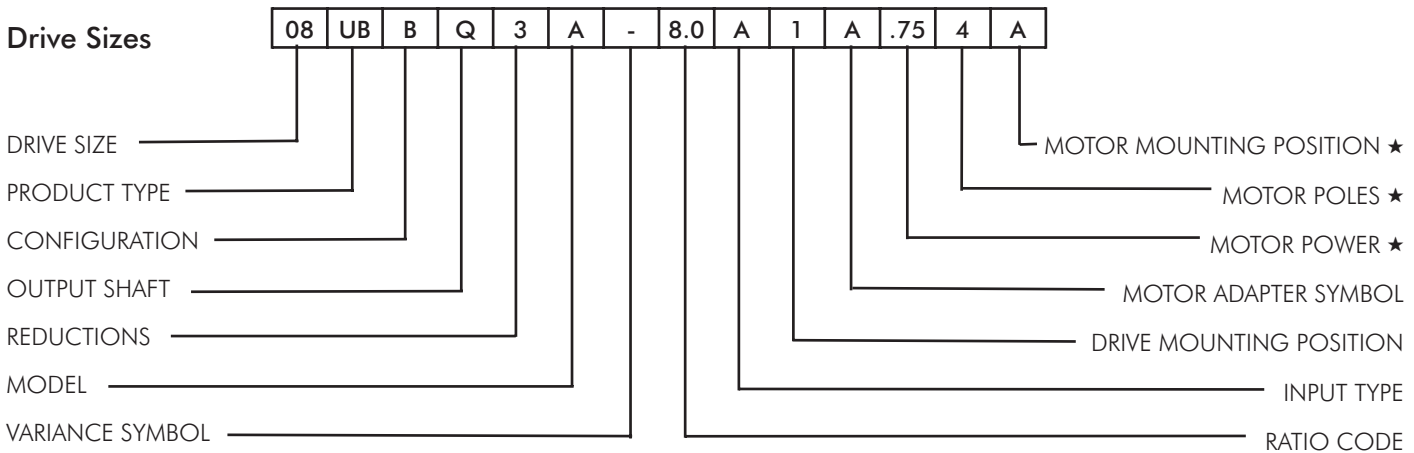

Drive Sizes

03, 04, 05, 06, 07, 08, 09, 10 & 12

Product Type

UB — Helical Bevel

Configuration

- B — Base Mounted (Integral Feet)
- F — Standard Output Flange
- J — With Torque Arm Bracket
- K — With Banjo Torque Arm Except 05, 06 & 07

Output Shaft

- Q — Inch Hollow
- B — Inch Single Ended, L.H. †
- C — Inch Single Ended, R.H. †
- D — Inch Double Ended
- E — Straight Metric Hollow
- F — Metric Single Ended, L.H. †
- G — Metric Single Ended, R.H. †
- H — Metric Double Ended
- J — Taper Hollow
- K — Taper Inch Single Ended, L.H. †
- L — Taper Metric Single Ended, R.H. †
- M — TA Taper Metric bushing (Bore Diameter)
- N — TA Taper Inch Bushing (Bore Diameter)
- P — CEMA Seal Housing & Drive Shaft (DS Diameters)
- R — Straight Hollow Bore with Shrink Disc

† When viewed from L.S. end.

Reductions

- 3 — Triple
- 5 — Quintuple

Model

A, B, C, etc.

Variance Symbol

Variance Symbol is omitted when Standard Mineral Lube and Single Seals are specified

- A — Standard Mineral Lube and Double Seals
- B — Synthetic Lube and Single Seals
- C — Biodegradeable Lube and Single Seals
- D — Food Compatible Lube and Single Seals
- E — Synthetic Lube with Double Seals
- F — Biodegradeable Compatible Lube With double Seals
- G — Food Compatible Lube With Double Seals
- H — Backstop (Hold Back)
- J — Cooling Fan - Shaft Driven
- S — Multiple Variances or Special

Ratio Code, Three Characters, Refer to Page 12 of UB Selection Guide 281-410

8.0 through 160 Triple Reduction

125 through 71C Quintuple Reduction C = 00 K = 000

Input Type

- A — Gear Drive With Flange Motor Adapter - NEMA Frame
- G — Gear Drive With Flange Motor Adapter - IEC Frame
- N — Gear Drive With Inch Input
- C — Gear Drive With Metric Input
- R — Gearmotor With Flange Motor Adapter - Special Motors

Drive Mounting Position, Refer to Page 13 of UB Selection Guide 281-410

Mounting Positions 1 through 6

Motor Adapter Symbol, Refer to Pages 16 & 17 of UB Selection Guide 281-410

A through W

Motor Power, Decimal Point Shown ★

Horsepower – NEMA Motor
Kilowatts – IEC Motor

Motor Poles ★

- 2 — Poles, 3600 rpm @ 60 Hz, or 3000 rpm @ 50 Hz
- 4 — Poles, 1800 rpm @ 60 Hz, or 1500 rpm @ 50 Hz
- 6 — Poles, 1200 rpm @ 60 Hz, or 1000 rpm @ 50 Hz
- 8 — Poles, 900 rpm @ 60 Hz, or 750 rpm @ 50 Hz

Motor Mounting Position, Refer to Page 13 ★ of UB Selection Guide 281-410

When Viewed from L.S. Shaft of Base Mounted Drive with Mounting Feet Down

- A — Conduit Box Horizontal on Right Side, 0°
- B — Conduit Box Vertical on Bottom Side, 90°
- C — Conduit Box Horizontal on Left Side, 180°
- D — Conduit Box Vertical on Top Side of Drive 270°

★ Motor Power, Motor Poles and Motor Mounting Position are stamped on the nameplate only if the motor is furnished & fitted by Rexnord.

Right Angle Bevel "UB" Interchange Accessories

- K** = Integral Foot and Solid O/P Shaft **UBBQ** Basic + O/P Shaft
KF = Integral Foot, Solid O/P Shaft and O/P Flange **UBBQ** Basic + O/P Flange + O/P Shaft
KA = Integral Foot and Hollow O/P Shaft **UBBQ** Basic
KAF = Integral Foot, Hollow O/P Shaft and O/P Flange **UBBQ** Basic + O/P Flange Kit
KH = Integral Foot with Shrink Disc and Hollow Shaft **UBBR** Basic Drive with Shrink Disc
 or
UBBJ Basic + TA Taper Bushing

EXAMPLE:

KF77 = **07UBFC** made from **07UBBQ** Basic Drive + "F" O/P Flange + "C" O/P Shaft right hand mount

Accessories

BASIC DRIVE FALK ULTRMITE	SEW	O/P Flange "F"	O/P Shaft "B"=LH "C"=RH	Final Nomenclature	Additional Accessories		
					Double O/P Shaft "D"=Double Ended	Banjo T/Arm "K"	Torque Arm Bracket "J"
03UBBQ	K37		X	UBBC	1940967	1940571	1940984 RH
03UBBQ	KF37	X	X	UBFC	-	-	1940985 LH
03UBBQ	KA37			UBBQ	-	-	-
03UBBQ	KAF37	X		UBFQ	-	-	-
03UBBR	KH37			UBBR	-	-	-
04UBBQ	K47		X	UBBC	1940968	1940572	1940986
04UBBQ	KF47	X	X	UBFC	-	-	-
04UBBQ	KA47			UBBQ	-	-	-
04UBBQ	KAF47	X		UBFQ	-	-	-
04UBBR	KH47			UBBR	-	-	-
05UBBQ	K57		X	UBBC	1940969	-	1940987 RH
05UBBQ	KF57	X	X	UBFC	-	-	1940988 LH
05UBBQ	KA57			UBBQ	-	-	-
05UBBQ	KAF57	X		UBFQ	-	-	-
05UBBR	KH57			UBBR	-	-	-
06UBBQ	K67		X	UBBC	1940970	-	1940989
06UBBQ	KF67	X	X	UBFC	-	-	-
06UBBQ	KA67			UBBQ	-	-	-
06UBBQ	KAF67	X		UBFQ	-	-	-
06UBBR	KH67			UBBR	-	-	-
07UBBQ	K77		X	UBBC	1940971	-	1940990
07UBBQ	KF77	X	X	UBFC	-	-	-
07UBBQ	KA77			UBBQ	-	-	-
07UBBQ	KAF77	X		UBFQ	-	-	-
07UBBR	KH77			UBBR	-	-	-
08UBBQ	K87		X	UBBC	1940659	1940575	1940660
08UBBQ	KF87	X	X	UBFC	-	-	-
08UBBQ	KA87			UBBQ	-	-	-
08UBBQ	KAF87	X		UBFQ	-	-	-
08UBBR	KH87			UBBR	-	-	-
09UBBQ	K97		X	UBBC	1940664	1940576	1670665
09UBBQ	KF97	X	X	UBFC	-	-	-
09UBBQ	KA97			UBBQ	-	-	-
09UBBQ	KAF97	X		UBFQ	-	-	-
09UBBR	KH97			UBBR	-	-	-
10UBBQ	K107		X	UBBC	1940787	1940782	1940788
10UBBQ	KF107	X	X	UBFC	-	-	-
10UBBQ	KA107			UBBQ	-	-	-
10UBBQ	KAF107	X		UBFQ	-	-	-
10UBBR	KH107			UBBR	-	-	-
12UBBQ	K127		X	UBBC	1940790	1940782	1940791
12UBBQ	KF127	X	X	UBFC	-	-	-
12UBBQ	KA127			UBBQ	-	-	-
12UBBQ	KAF127	X		UBFQ	-	-	-
12UBBR	KH127			UBBR	-	-	-

Falk UB Ultramite vs. SEW Series K

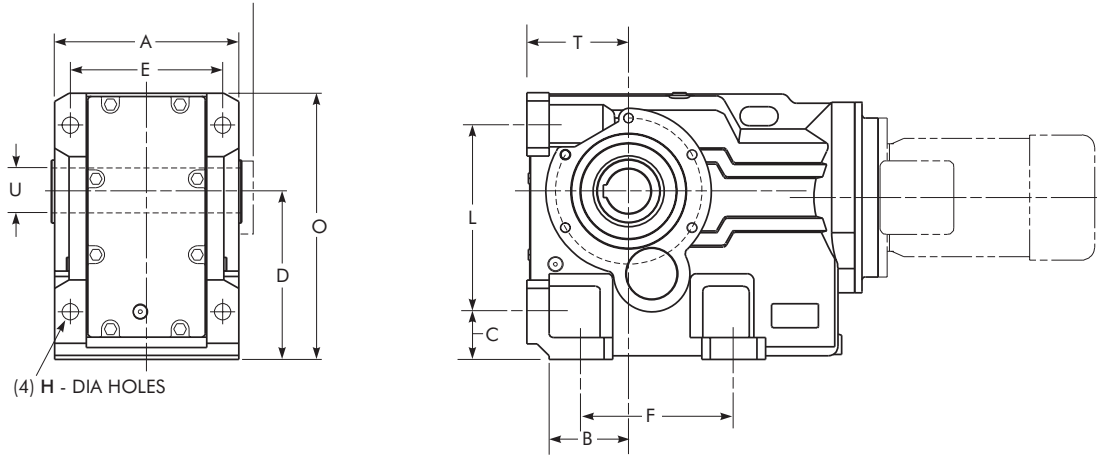

Interchange Data — Inches

SIZE	Torque ★ (lb - in.)	A	B	C	D	E	F	H	O	L	T	U
FALK 03UB SEW K37	1792 1780	4.72	1.10	1.26	3.94	3.94	4.33	0.43	6.57 6.46	4.53	2.48	1.250
FALK 04UB SEW K46 SEW K47	3449 2650 3705	5.71	1.38	1.46	4.41	4.72	5.12	0.43	7.36 7.68 7.32	5.12	2.80	1.375
FALK 05UB SEW K57	5514 5412	6.18	1.18	1.77	5.20	5.12	5.12	0.55 0.53	8.54	5.91	3.15	1.500
FALK 06UB SEW K66 SEW K67	7732 4050 7200	6.69	1.18	1.77	5.51	5.51	4.72	0.55 0.55 0.53	9.17 8.86 8.98	6.30	3.54 3.50 3.54	1.500
FALK 07UB SEW K76 SEW K77	14,120 9160 13,620	7.87	1.57	2.17	7.09	6.50	5.91	0.71 0.71 0.69	11.34 11.22 11.34	7.87	4.41 4.25 4.41	2.000
FALK 08UB SEW K86 SEW K87	23,500 16,020 21,792	9.06	2.17	2.76	8.35	7.09	7.09	0.91 0.87 0.87	13.43 13.31 13.39	9.17	5.20 4.88 5.20	2.3750
FALK UB09 SEW K96 SEW K97	37,000 26,500 37,520	11.42	2.95	2.95	10.40	9.45	9.45	1.06 1.02 1.02	16.54 16.26 16.42	11.61	6.30 6.02 6.30	2.750
FALK 10UB SEW K106 SEW K107	72,800 56,400 91,125	13.39	3.74	3.74	12.40	10.63	11.02	1.34 1.30 1.30	19.88 19.45 19.80	14.17	7.87 7.48 7.87	3.250
FALK 12UB SEW K126 SEW K127	117,000 91,125 115,130	15.75	4.53	4.33	14.76	12.99	13.78	1.54	23.23 23.43 23.31	16.54	8.86 8.66 8.86	4.000

★ Torque is based on closest cataloged 25:1 ratio with 1750 rpm input.

Falk UB Ultramite vs. SEW Series K Accessories

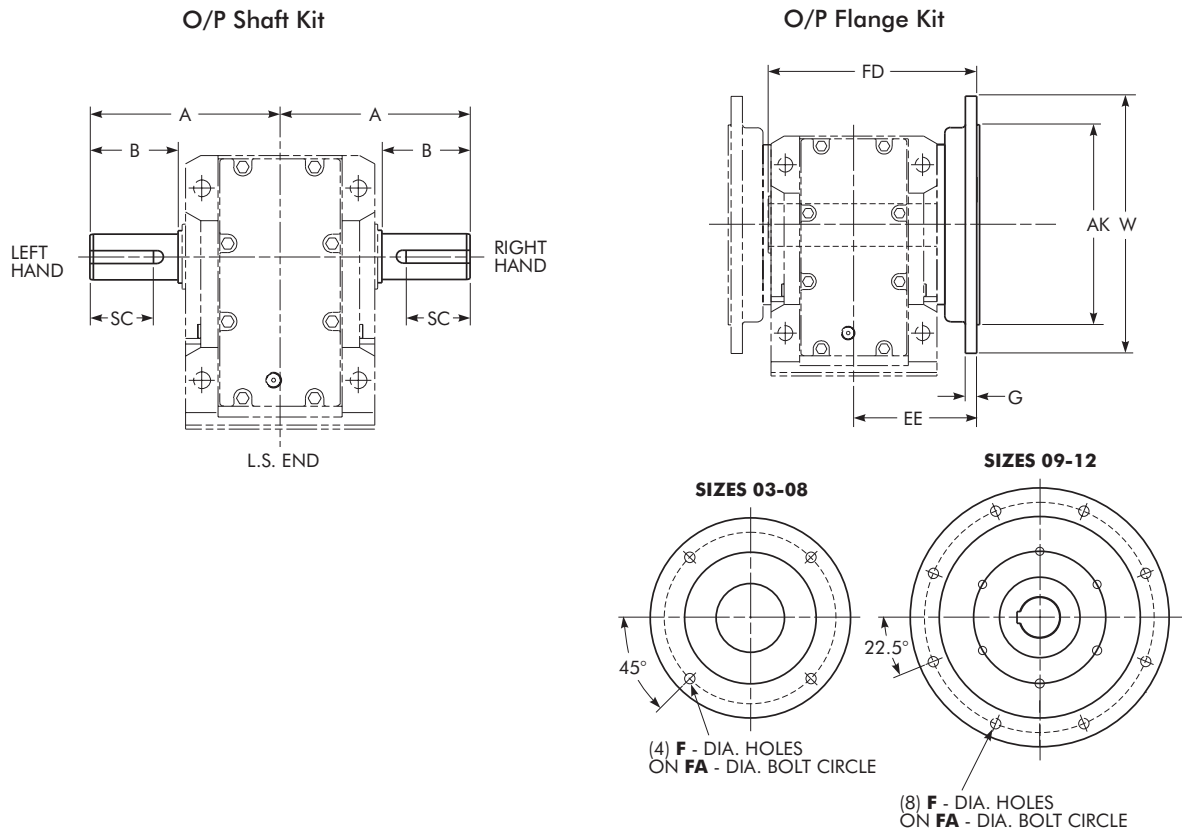

Accessories Interchange Data — Data

SIZE	A	B	Single Ext O/P Shaft Diameter	SC Single	Double Ext O/P Shaft Diameter	SC Double	FD	EE	G	AK	W	FA	F
FALK 03UB SEW K37	4.33	1.85 1.97	1.0000	1.4375 1.3125	1.0000	1.4375 1.3125	5.67 5.57	3.31	0.39	4.33	7.09 6.30	5.12	0.35
FALK 04UB SEW K46 SEW K47	5.31	2.20 2.36 2.36	1.2500	2.0000 2.3600 1.3875	1.2500	2.0000 2.3600 1.6875	7.48 6.50 6.77	4.53 3.70 3.94	0.47	5.12	7.87	6.50	0.43
FALK 05UB SEW K57	6.02	2.60 2.76	1.3750	2.3750 2.7600	1.3750	2.3750 2.7600	7.44 7.36	4.17 4.21	0.63 0.59	7.09	9.84	8.46	0.55 0.53
FALK 06UB SEW K66 SEW K67	6.73 6.34 6.73	3.00 2.76 3.15	1.6250 1.3750 1.6250	2.3750 2.7600 3.1500	1.5000 1.3750 1.6250	2.3750 2.7600 3.1500	8.66 7.94 7.86	5.12 4.44 4.75	0.63 0.59 0.59	7.09	9.84	8.46	0.55 0.55 0.53
FALK 07UB SEW K76 SEW K77	8.11 7.72 8.11	3.74 3.54 3.94	2.0000 1.7500 2.0000	2.7500 3.5400 3.9400	2.0000 1.7500 2.0000	2.7500 3.5400 3.9400	9.72 9.68 9.57	5.59	0.71 0.59 0.63	9.06 7.09 9.06	11.81 9.84 11.81	10.43 8.46 10.43	0.55 0.55 0.53
FALK 08UB SEW K86 SEW K87	9.45	4.49 4.72 4.72	2.3750	3.6875 4.7200 4.7200	2.3750	3.6875 4.7200 4.7200	11.22 10.51 11.34	6.50 5.59 5.91	0.71 0.79 0.71	9.84	13.78	11.81	0.71 0.71 0.69
FALK 09UB SEW K96 SEW K97	11.46	5.32 5.51 5.51	2.8750	4.6250 5.5100 5.5100	2.6250 2.8750 2.8750	3.6875 5.5100 5.5100	13.82 13.47 14.29	7.92 7.56 7.56	0.79 0.87 0.87	13.78	17.72	15.75	0.71 0.71 0.69
FALK 10UB SEW K106 SEW K107	13.31 13.66 13.66	6.42 6.69 6.69	3.6250	5.9375 6.6900 6.6900	3.1250 3.6250 3.6250	4.6250 6.6900 6.6900	16.16 15.40 15.40	9.27 8.51 8.51	0.87	13.78	17.72	15.75	0.71 0.71 0.69
FALK 12UB SEW K126 SEW K127	15.94 16.46 16.46	7.87 8.27 8.27	4.3750	6.5000 8.2700 8.2700	3.8750 4.3750 4.3750	6.5000 8.2700 8.2700	18.52 18.94 18.07	10.46 10.08 10.08	0.87 0.98 0.98	13.78 17.72 17.72	17.72 21.65 21.65	15.75 19.69 19.69	0.71 0.71 0.69

SEW — Eurodrive® Nomenclature

The SEW-Eurodrive Model number consists of a series of letters to designate the type of drive or feature and numbers to designate the size of the drive. The motor number always begins with the output side of the drive and ends with the input side.

Gear Drive Types

R	Foot Mounted
RF	Flange Mounted
R..F	Foot/Flange Mounted (R27-87 only)
RM	Flange Mounted Agitator Type with Extended Bearing Housing
RX	Foot Mounted - Single Stage
RXF	Flange mounted - Single Stage
R..R	Compound Gear Drive
F	Foot Mounted
FF	Flange Mounted
FA	Shaft Mounted
FAF	Shaft Mounted with Flange
FAZ	Face Mounted
FA..B	Foot Mounted with Hollow Shaft
FH	Shrink Disc Hollow Shaft Mounted
FH..B	Foot Mounted with Shrink Disc
FV	Splined Hollow Shaft Mounted
FV..B	Foot Mounted with Splined Hollow Shaft
FHF	Flange Mounted with Shrink Disc
FVF	Flange Mounted with Splined Hollow Shaft
FHZ	Face Mounted with Hollow Shaft
FVZ	Face Mounted with Splined Hollow Shaft
F..R	Compound Gear Drive
K	Foot Mounted
KF	Flange Mounted
KA	Shaft Mounted
KAF	Shaft Mounted with Flange
KAZ	Face Mounted
KA..B	Foot Mounted with Hollow Shaft
KH	Shrink disc Hollow Shaft Mounted
KH..B	Foot Mounted with Shrink Disc
KV	Splined Hollow Shaft Mounted
KV..B	Foot Mounted with Splined Hollow Shaft
KHF	Flange Mounted with Shrink Disc
KVF	Flange Mounted with Splined Hollow Shaft
KHZ	Face Mounted with Hollow Shaft
KVZ	Face Mounted with Splined Hollow Shaft
K..R	Compound Gear Drive
S	Foot Mounted Helical-Worm
SF	Flange Mounted Helical-Worm
SA	Shaft Mounted Helical-Worm
SAF	Flange Mounted with Hollow Shaft Helical-Worm
S..R	Compound Gear Drive with Helical-Worm
SH	Shaft Mounted with Hollow Shaft Helical-Worm
SHF	Flange Mounted with Shrink Disc Helical-Worm

Gear Drive Features

T	Torque Arm
KS	Severe Duty Option

Non-Integral Motor Input Options

A	Input Side Open For Flange Mounting Of Primary Drives
AD..	Input Shaft Assembly
AD..P	Input Shaft Assembly And Motor Mounting Platform
AD..ZR	Input Shaft Assembly Machined To Provide A Centering Shoulder
AD../RS	Backstop (Anti-Reversal Feature)
AD..ZS	Scoop Motor Mount
AM	Adapter With Coupling For Mounting Non-Integral Motors
AQ	Adapter With Coupling For Mounting Servomotors

Extended Housing/Adapter Types

AR	Adapter with Torque Limiting Coupling
AT	Extended Housing with Hydraulic Centrifugal Coupling

Extended Housing/Adapter Features

BM(G)HF	Disc Brake with Manual Brake Release (Lockable in the Released Position)
BM(G)HR	Disc Brake with Manual Brake Release (Self Re-engaging)
W	Speed Monitor

Motor Types

DT, DV	AC Squirrel-Cage Motor
SDT, SDV	Integral Mounted or Foot Mounted
DFT	
DFV	AC Squirrel-Cage Motor
SDFT	Flange Mounted
SDFV	
DT..F	
DV..F	AC Squirrel-Cage Motor
SDT..F	Foot/Flange Mounted
SDV..F	

Motor Features

BM, BMG	Disk Brake
C	Fan Guard with Canopy
HF	Manual Brake Release (Lockable in the released position)
HR	Manual Brake Release (Self Re-engaging)
IS	Integrated Plug connector
KS	Severe Duty Option
MM..	MOVIMOT® (Integrated Frequency Inverter)
RS	Backstop (Anti-Reversal Feature)
TF	Thermistor Protection
TH	Thermostat Protection
U	Frame Cooled (Non-Ventilated)
Z	High Inertia Fly-Wheel Fan

SEW – Eurodrive Motor Data

AC Motors & Brake Motors Synchronous Speed 1800 rpm @ 60 Hz 4 Pole

Frame Size	hp	kW	rpm	230V	C-Face Frame Size	Falk C-Face Adapter Symbol	Falk Energy Efficient NEMA-C-Face P/N	Falk Brakemotor NEMA C-Face P/n
DT71K4	0.2	0.15	1700	1.19	56C	A – A	1940393	2921832
DT71C4	0.33	0.25	1700	1.4	56C	A – A	1940394	2921832
DT71D4	0.5	0.37	1700	2.15	56C	A – A	1940395	2921832
DT80K4	0.75	0.55	1700	3.05	56C	A – A	1940396	2921833
DT80N4	1	0.75	1700	3.9	143TC	A – B	1940397	2921834
DT90S4	1.5	1.1	1700	4.75	145TC	A – B	1940398	2921835
DT90L4	2	1.5	1720	6.0	145TC	A – B	1940399	2921836
DT100LS4	3	2.2	1700	8.6	182TC	A – C	1940400	2921837
DT100L4	5	3.7	1680	13.6	184TC	A – C	1940401	2921838
DV112M4	5.4	4.0	1720	15.2	213TC	A – D	1940402	2921839
DV132S4	7.5	5.5	1730	19.2	213TC	A – D	1940402	2921839
DV132M4	10	7.5	1740	26	215TC	A – D	1940403	2921840
DV132ML4	12.5	9.2	1740	31.5	254TC	A – E	1940404	
DV160M4	15	11	1740	36.5	254TC	A – E	1940404	
DV160L4	20	15	1760	51	256TC	A – E	1940405	
DV180M4	25	18.5	1760	64	284TC	A – F	1940406	
DV180L4	30	22	1760	74	286TC	A – F	1940407	
DV200L4	40	30	1760	96	324TC	A – G	1940408	
DV225S4	50	37	1760	117	326TC	A – G	1940409	
DV225M4	60	45	1760	142	364TC	A – H	Consult Rexnord	

Consult Rexnord

AC Motors & Brake Motors Synchronous Speed 3600 rpm @ 60 Hz 2 Pole

FRAME SIZE	hp	kW	rpm
DT71K2	0.33	0.25	3100
DT71C2	0.5	0.37	3300
DT71D2	0.75	0.55	3300
DT80K2	1	0.75	3300
DT80N2	1.5	1.1	3300
DT90S2	2	1.5	3300
DT90L2	3	2.2	3330
DT100L2	5	3.7	3370
DV132S2	7.5	5.5	3480
DV132M2	10	7.5	3500
DV132ML2	12.5	9.2	3490
DV160M2	15	11	3500
DV160L2	20	15	3510
DV180M2	25	18.5	3510
DV180L2	30	22	3510

AC Motors & Brake Motors Synchronous Speed 1200 rpm @ 60 Hz 6 Pole

FRAME SIZE	hp	kW	rpm
DT71C6	0.20	0.15	1100
DT71D6	0.33	0.25	1100
DT80K6	0.5	0.37	1100
DT80N6	0.75	0.55	1100
DT90S6	1	0.75	1100
DT90L6	1.5	1.1	1120
DT100L6	2	1.5	1120
DV112M6	3	2.2	1140
DV132S6	4	3	1140
DV132M6	5	3.7	1170
DV132ML6	7.5	5.5	1160
DV160M6	10	7.5	1160
DV160L6	15	11	1160
DV180L6	20	15	1170
DV200LS6	25	18.5	1170
DV200L6	30	22	1170

THIS PAGE INTENTIONALLY LEFT BLANK

THIS PAGE INTENTIONALLY LEFT BLANK

World Class Customer Service

For more than 100 years, the dedicated people of Rexnord have delivered excellence in quality and service to our customers around the globe. Rexnord is a trusted name when it comes to providing skillfully engineered products that improve productivity and efficiency for industrial applications worldwide. We are committed to exceeding customer expectations in every area of our business: product design, application engineering, operations, and customer service.

Because of our customer focus, we are able to thoroughly understand the needs of your business and have the resources available to work closely with you to reduce maintenance costs, eliminate redundant inventories and prevent equipment down time.

Rexnord represents the most comprehensive portfolio of power transmission and conveying components in the world with the brands you know and trust.

Rexnord, Renew, and Steelflex are registered trademarks of Rexnord Industries, LLC. Falk is a trademark of Rexnord. All rights reserved.

WORLDWIDE CUSTOMER SERVICE

AUSTRALIA

Rexnord Australia Pty. Ltd.
Picton, New South Wales
Phone: 61-2-4677-3811
Fax: 61-2-4677-3812

BRAZIL

Rexnord Correntes Ltda.
Sao Leopoldo - RS
Phone: 55-51-579-8022
Fax: 55-51-579-8029

CANADA

Rexnord Canada Ltd.
Scarborough, Ontario
Phone: 1-416-297-6868
Fax: 1-416-297-6873

CHINA

Rexnord China
Shanghai, China
Phone: 86-21-62701942
Fax: 86-21-62701943

EUROPE

Rexnord NV/SA
Mechelen, Belgium
Phone: 32-15-443811
Fax: 32-15-443860

Rexnord Kette GmbH
Betzdorf, Germany
Phone: 49-2741-2840
Fax: 49-2741-284-385

LATIN AMERICA

Rexnord International, Inc.
Milwaukee, Wisconsin
Phone: 1-414-643-2366
Fax: 1-414-643-3222
E-mail: international2@rexnord.com

MEXICO

Rexnord S.A. de C.V.
Queretaro, Qro.
Phone: 52-442-218-5000
Fax: 52-442-218-1090

SINGAPORE

Rexnord International, Inc.
Singapore City, Singapore
Phone: 65-6338-5622
Fax: 65-6338-5422

UNITED STATES

Customer Service
Phone: 1-866-REXNORD
(1-866-739-6673)
Fax: 1-614-675-1898
E-mail:
rexnordcs(state)@rexnord.com
Example:
rexnordcsohio@rexnord.com

ALL COUNTRIES NOT LISTED

Rexnord International
Milwaukee, Wisconsin
Phone: 1-414-643-2366
Fax: 1-414-643-3222
E-mail: international1@rexnord.com

