

Technical Information



TI No. WL 90-30 E

February 2001

FAG Series Housings



FAG Series Housings

Contents

| | |
|---------------------------|---|
| FAG Series housings | 2 |
|---------------------------|---|

Plummer block housings

| | |
|------------|----|
| BND | 3 |
| BNDG | 4 |
| BNM | 5 |
| FS | 6 |
| KPG | 7 |
| KPGZ | 8 |
| LOE | 9 |
| LOU | 10 |
| MGO | 11 |
| NGO | 12 |
| PM | 13 |
| PMD | 14 |
| PMDR | 15 |
| RA | 16 |
| RLE | 17 |
| S30 | 18 |
| S39 | 19 |
| SD | 20 |
| SD31 | 21 |
| SDK | 22 |
| SNV | 23 |
| TN | 24 |
| TVN | 25 |
| VO | 26 |
| VR3 | 27 |

Flanged housings

| | |
|------------|----|
| F112 | 28 |
| F5 | 29 |
| FER | 30 |

Take-up housings

| | |
|-----------|----|
| SPA | 31 |
|-----------|----|

FAG Series Housings

FAG Series housings

FAG housings and the bearings for which they are suitable form bearing units which are successfully used in machines, plants and devices. However, out of the many sizes and designs available from FAG only a selection can be presented in this publication. These so-called series housings were designed for several sizes of individual bearing series. Within one and the same series the housing dimensions vary with the bearing size but the housing design is the same.

FAG series housings are available both as split and non-split plummer block housings, flanged housings or take-up housings.

Data files for series housings that were created in the CAD system can be ordered from FAG (address see cover page 4). Pictorial representations in the TI are generally in accordance with existing CAD data.

If you should need other housings or housing designs please contact FAG.

Material

Depending on the housing series the standard material of which the housing bodies are made is grey-cast iron (GG), cast steel (GS) or nodular cast iron (GGG). If a material other than the standard material is required, this has to be indicated as a suffix.

Lubrication

As the bearings are usually lubricated with grease, and the initial grease fill lasts for a long time, most housings feature no relubricating holes. There are, however, sprues for markings so that lubricating holes can be provided if necessary.

Some housings are suitable for both grease and oil lubrication whereas others are designed exclusively for oil lubrication.

Bearing seat and bearing mounting

The bearing seats in the housing are, as a rule, machined in such a way that the bearings are displaceable, i.e. they act as floating bearings. The bearings can act as locating bearings if locating rings are inserted. Housings without locating rings are available both as floating bearing housings (L) and locating bearing housings (F).

Bearings with a cylindrical bore are seated directly on the shaft. Bearings with a tapered bore (suffix K) are either mounted on the shaft with adapter sleeves or withdrawal sleeves or are seated directly on a tapered trunnion.

Coat of paint

All outer surfaces of FAG series housings and housing components that were not machined are protected by a universal coat of paint (colour RAL 7031, bluish grey). The coat of paint can be overpainted with every synthetic, polyurethane, acrylic, epoxy resin, chlorinated rubber, nitrocellulose and acid hardening hammer dimple enamel.

Sealing

The bearing housings can be sealed, depending on the operating conditions, by means of rubbing seals, non-rubbing seals or combinations of both.

FAG Series Housings

Plummer block housings

BND

Plummer block housings, non-split

Shaft diameter 60 to 420 mm

Type of lubrication: grease

Labyrinth seal (on request also Taconite seal)

Standard housing-body material: GS

Application: e.g. belt conveyors

Housing sizes

Bearing sizes
(spherical roller bearings
with cylindrical bore)

(spherical roller bearings
with tapered bore and
adapter sleeve)

BND2213 to BND2284

22213E to 22284

22213EK to 22284K

BND3024 to BND3084

23024ES to 23084

23024ESK to 23084BK

BND3122 to BND3184

23122ES to 23184

23122ESK to 23184K

BND3222 to BND3284

23222ES to 23284

23222ESK to 23284BK

FAG publication:

Catalogue WL 41 520/3 EA

CAD files in existence

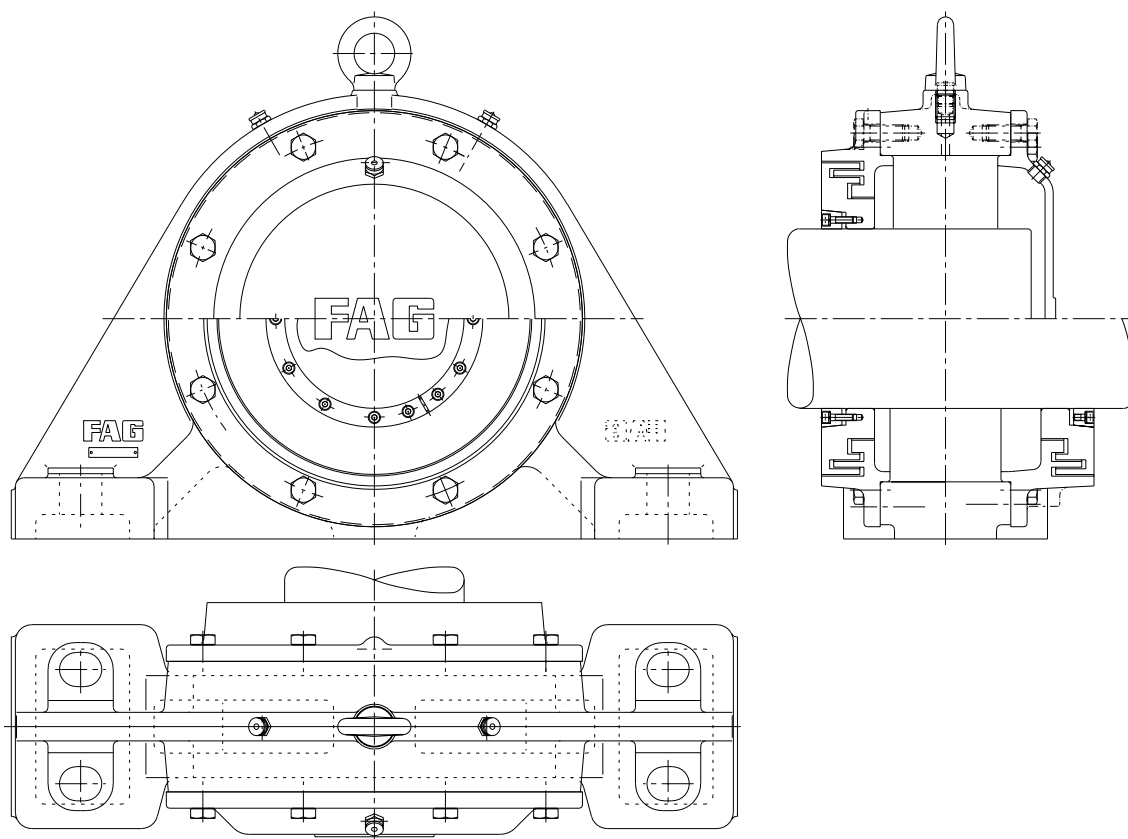

FAG Series Housings

Plummer block housings

BNDG

Plummer block housings, split

Shaft diameter 60 to 420 mm

Type of lubrication: grease

Labyrinth seal (on request also Taconite seal)

Standard housing-body material: GGG

Application: e.g. belt conveyors

Housing sizes

Bearing sizes
(spherical roller bearings
with cylindrical bore)

(spherical roller bearings
with tapered bore and
adapter sleeve)

BNDG2213 to BNDG2284

22213E to 22284

22213EK to 22284K

BNDG3024 to BNDG3084

23024ES to 23084B

23024ESK to 23084BK

BNDG3122 to BNDG3184

23122ES to 23184

23122ESK to 23184K

BNDG3222 to BNDG3284

23222ES to 23284B

23222ESK to 23284BK

FAG publication:

Dimension sheet

CAD files in existence

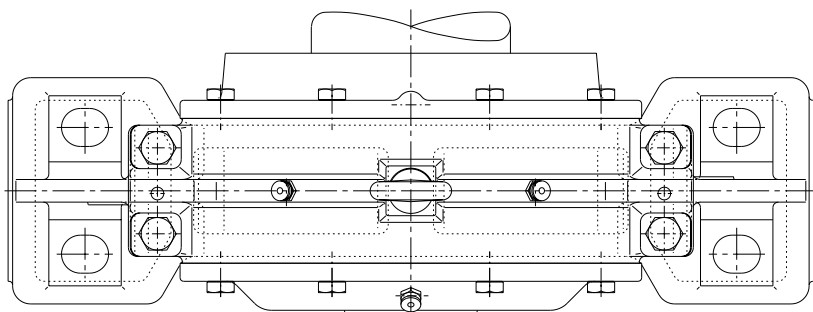
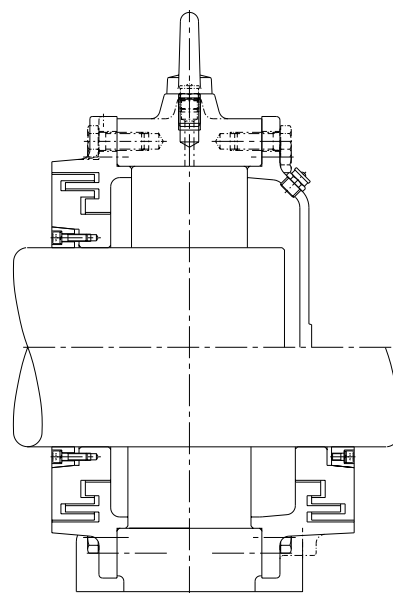
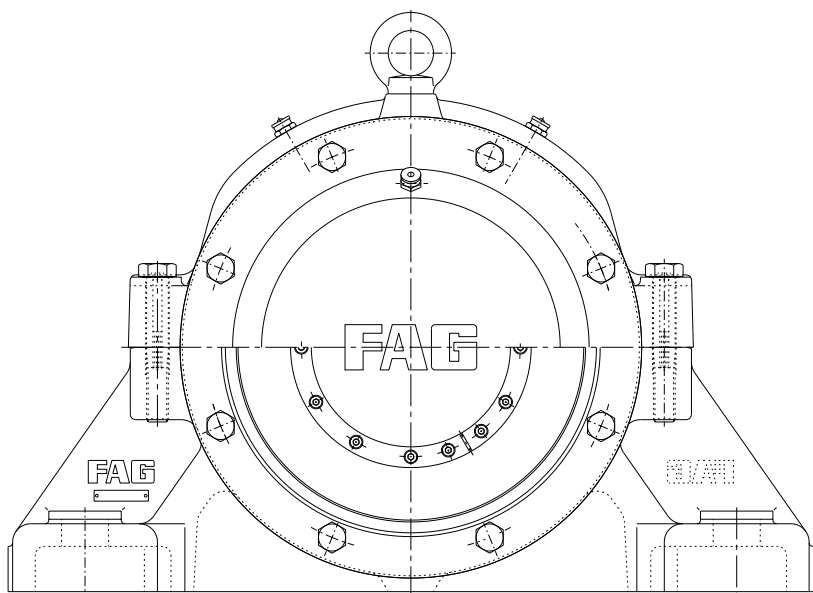

FAG Series Housings

Plummer block housings

BNM

Plummer block housings, non-split

Shaft diameter 140 to 400 mm

Type of lubrication: grease

Labyrinth seal

Standard housing-body material: GS

Application: e.g. mills

Housing sizes

Bearing sizes (spherical roller bearings with tapered bore and withdrawal sleeve)

BNM3232KR to BNM3284KR

23232ESK to 23284BK

FAG publication:

Dimension sheet

CAD files in existence for some housings

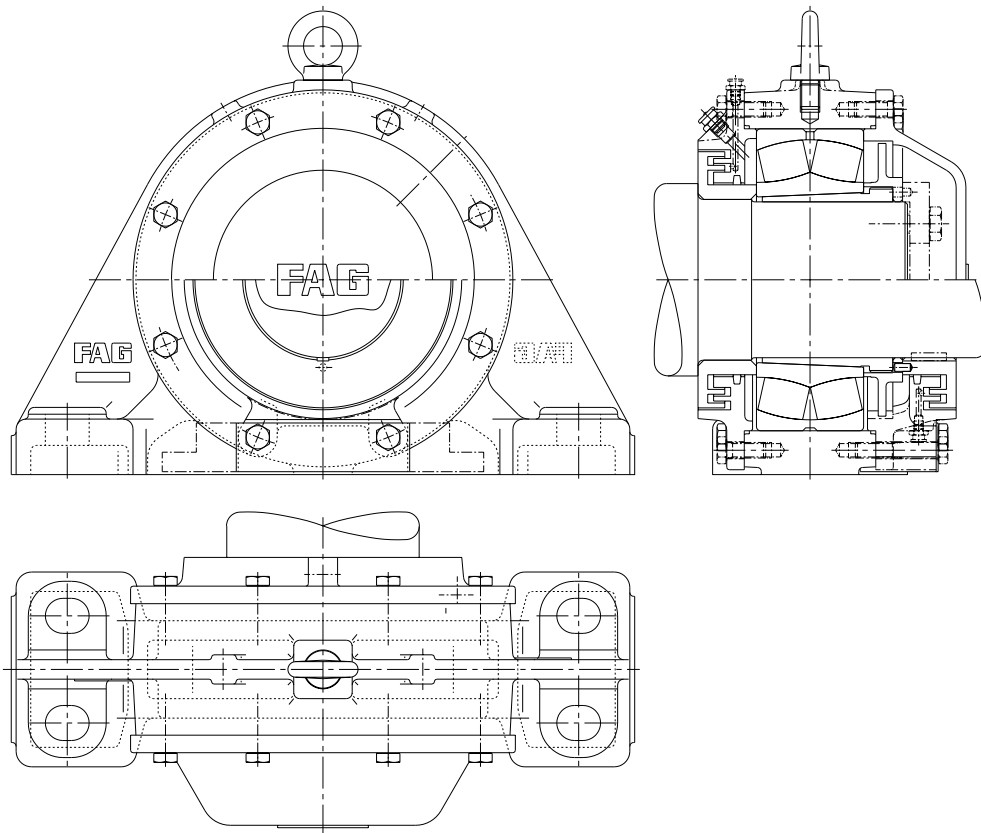

FAG Series Housings

Plummer block housings

FS

Plummer block housings, split

Shaft diameters 95 to 480 mm

Main dimensions standardized in DIN 22 410

Type of lubrication: grease

Labyrinth seal

Standard housing-body material: GG

Application: e.g. rope sheaves for underground mining

Housing sizes

Bearing sizes (spherical roller bearings with tapered bore and withdrawal sleeve)

FS2220AH to FS2222AH

22220EK to 22224EK

FS2324AH to FS2344AH

22324EDK to 22344K

FS3252AH to FS3276AH

23252K to 23276BK

FS4184AH to FS41/500AH

24184BK30 to 241/500BK30

FAG publication:

Publ. Nr. WL 14 102 DA

CAD files in existence for some housings

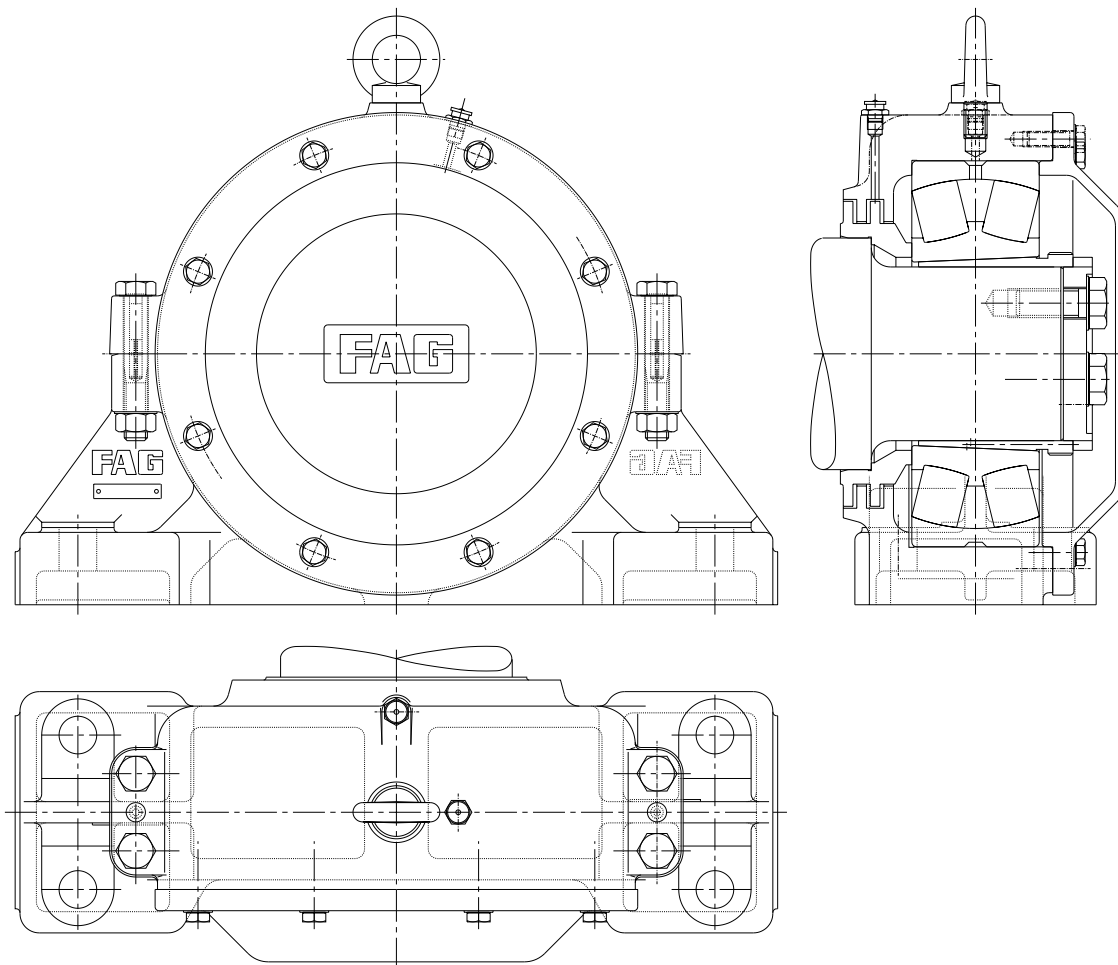

FAG Series Housings

Plummer block housings

KPG

Plummer block housings, split

Shaft diameters 470 to 1250 mm

Type of lubrication: grease

Sealed by extreme-pressure packings

Standard housing-body material: GS

Application: e.g. converters

Housing sizes

Bearing sizes (spherical roller bearings with tapered bore and wedge sleeve)

KPG49/470 to KPG49/1250

249/500K30 to 249/1320K30

FAG publication:

Publ. No. WL 17 104/2 EA

CAD files in existence for some housings

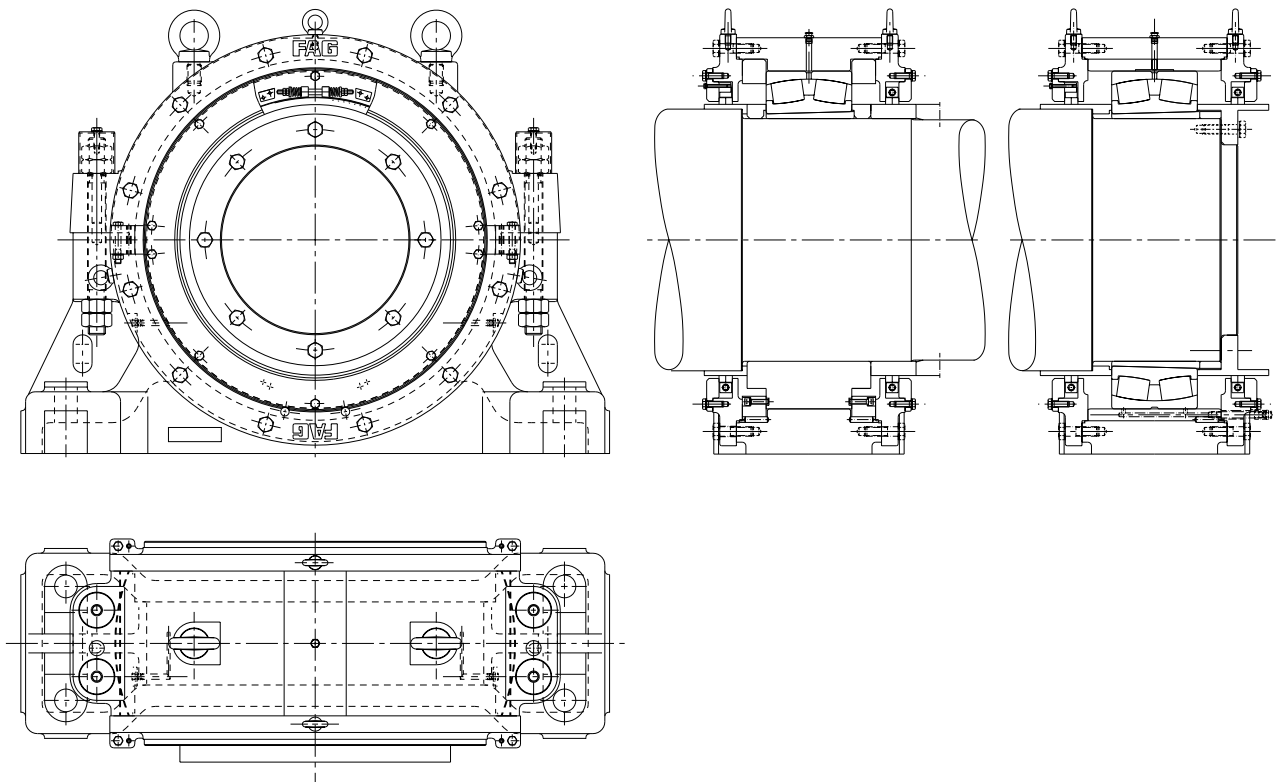

FAG Series Housings

Plummer block housings

KPGZ

Plummer block housings, split

Shaft diameters 500 to 1320 mm

Type of lubrication: grease

Sealed by extreme-pressure packings

Standard housing-body material: GS

Application: e.g. converters

Housing sizes

Bearing sizes (spherical roller bearings with cylindrical bore)

KPGZ49/500 to KPGZ49/1320

249/500 to 249/1320

FAG publication:

Publ. No. WL 17 104/2 EA

CAD files in existence for some housings

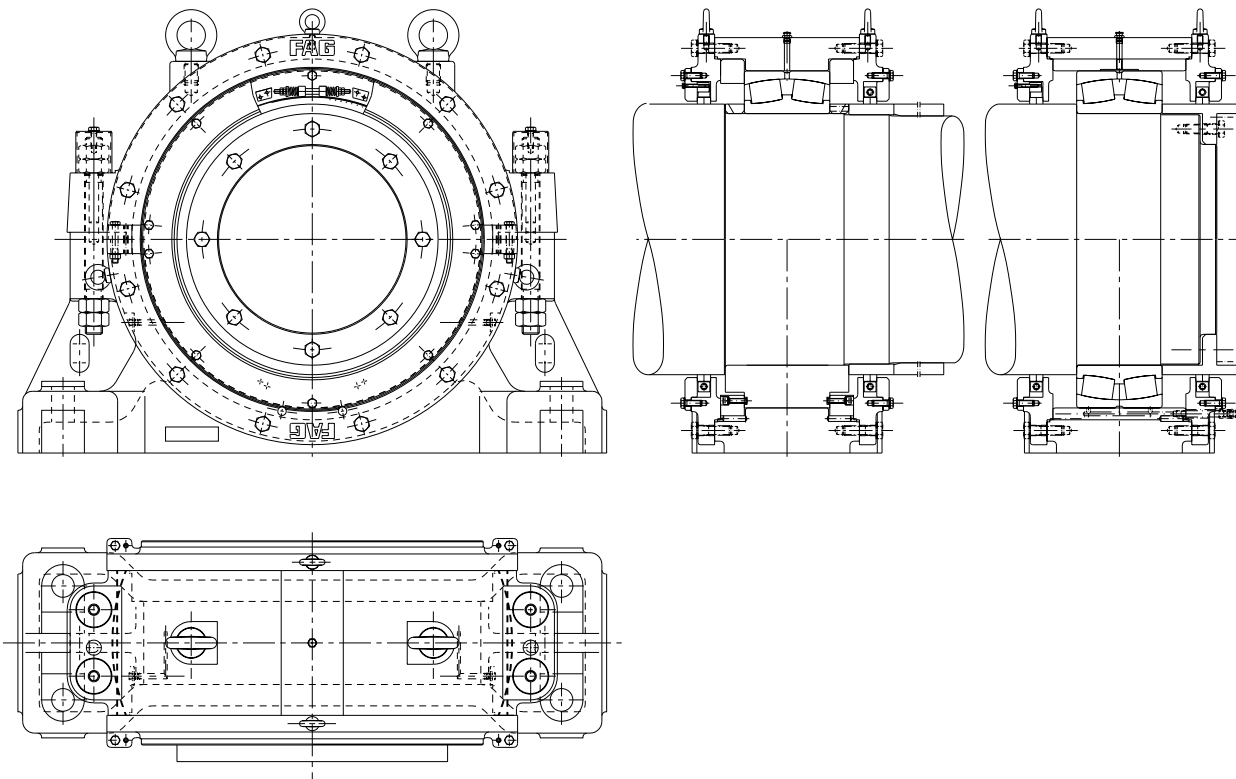

FAG Series Housings

Plummer block housings

LOE

Plummer block housings, split

Shaft diameters 50 to 240 mm

Type of lubrication: oil sump

Labyrinth seal

Standard housing-body material: GG

Application: e.g. ventilators

Housing sizes

LOE214 to LOE248

LOE310 to LOE336

LOE517 to LOE548

LOE614 to LOE636

Bearing sizes (spherical roller bearings)

22214E to 22248B

22310E to 22336

22217EK to 22248BK

22314EK to 22336K

(bearings with
cylindrical bore)

(bearings with tapered bore
and adapter sleeve)

FAG publication:

Catalogue WL 41 520/3 EA

CAD files in existence for
some housings

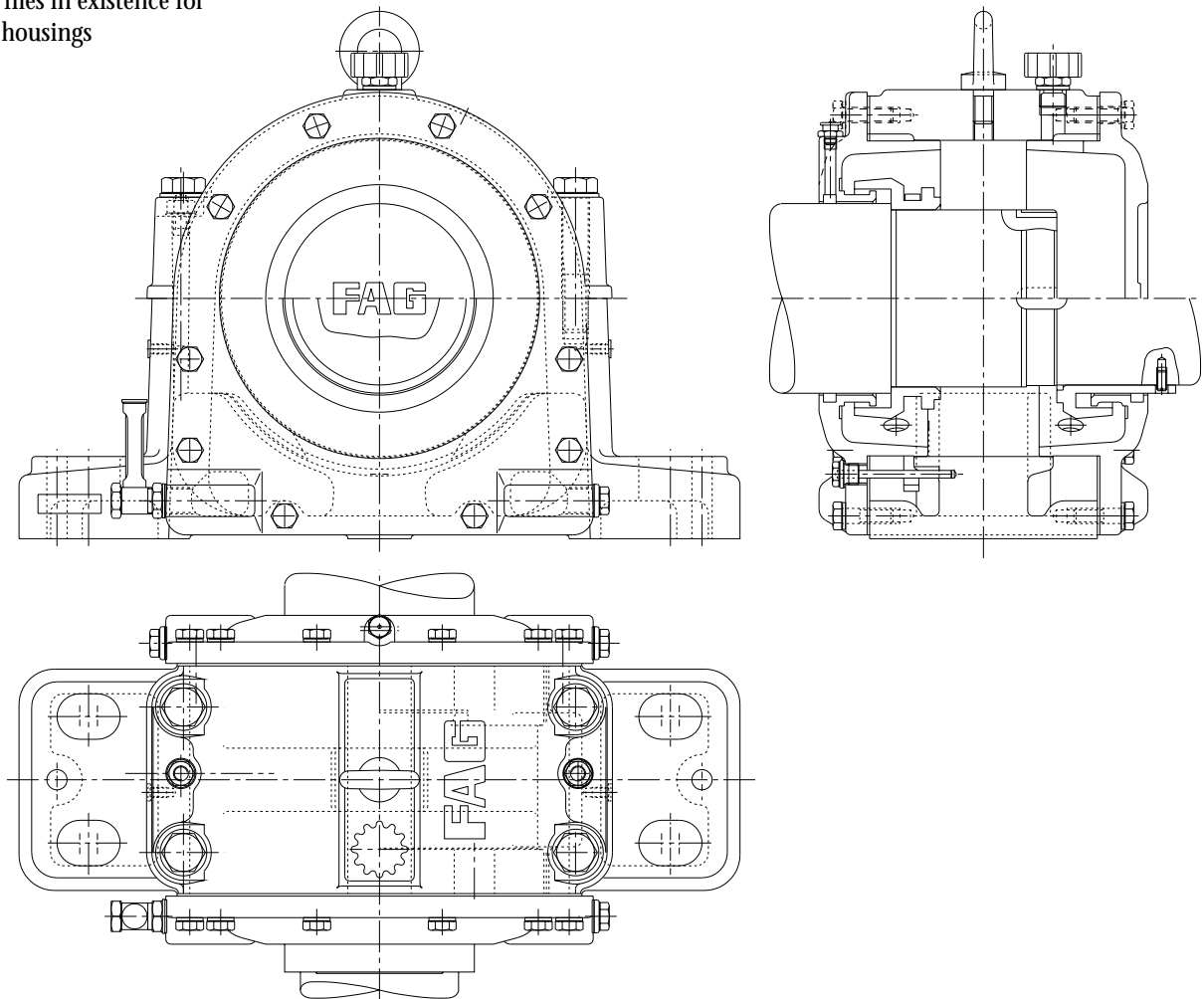

FAG Series Housings

Plummer block housings

LOU

Plummer block housings, split
Shaft diameters 50 to 240 mm
Type of lubrication: oil circulation
Labyrinth seal
Standard housing-body material: GG
Application: e.g. ventilators

Housing sizes

Bearing sizes (spherical roller bearings with cylindrical bore)

LOU214 to LOU248
LOU310 to LOU336

22214E to 22248B
22310E to 22336

FAG publication:
Dimension sheet

CAD files in existence for some housings

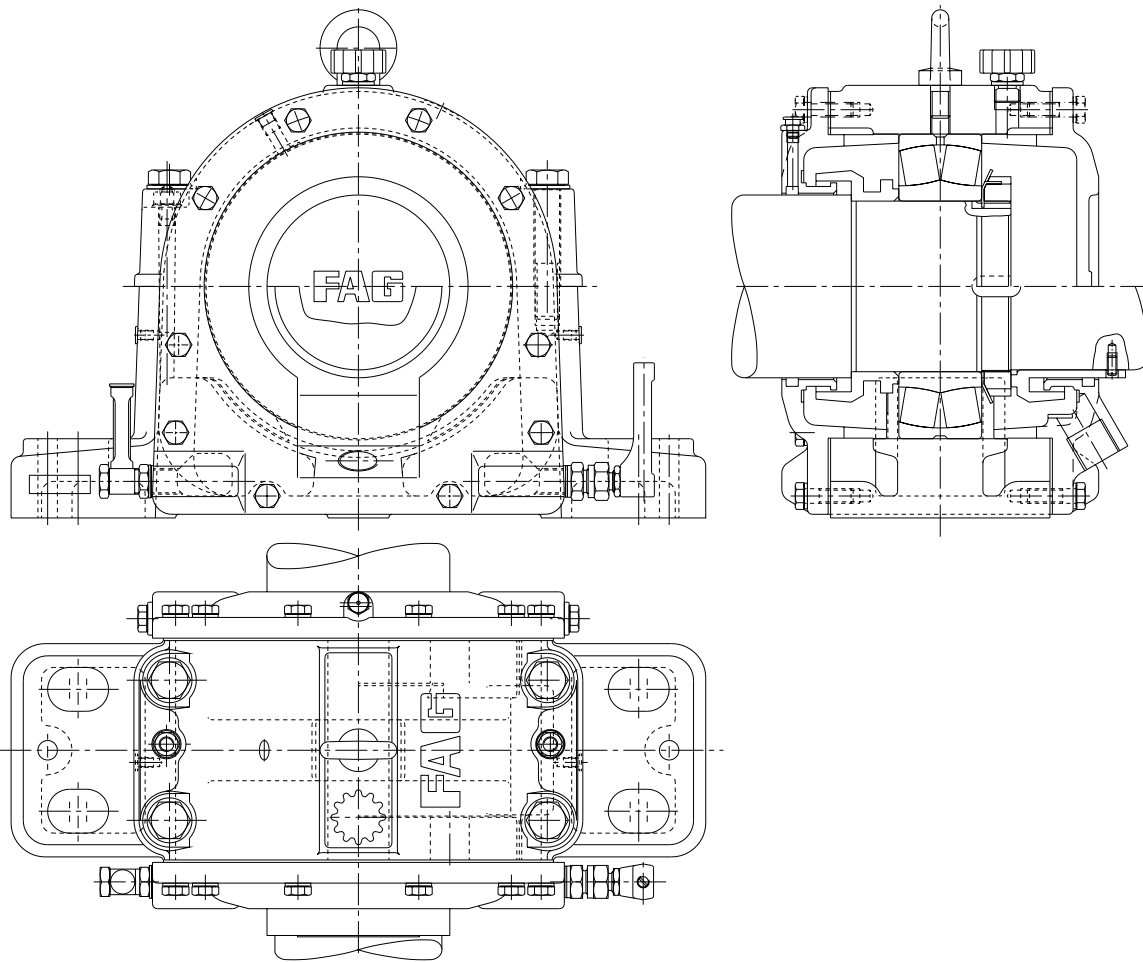

FAG Series Housings

Plummer block housings

MGO

Plummer block housings, split
Shaft diameters 125 to 400 mm
Type of lubrication: oil sump
Labyrinth seal
Standard housing-body material: GGG
Application: e.g. mills

Housing sizes

Bearing sizes (spherical roller bearings with tapered bore and withdrawal sleeve)

MGO3130AH to MGO3184AH
MGO3228K to MGO3284K

23130ESK to 23184K
23228ESK to 23284BK

FAG publication:
Dimension sheet

CAD files in existence for some housings

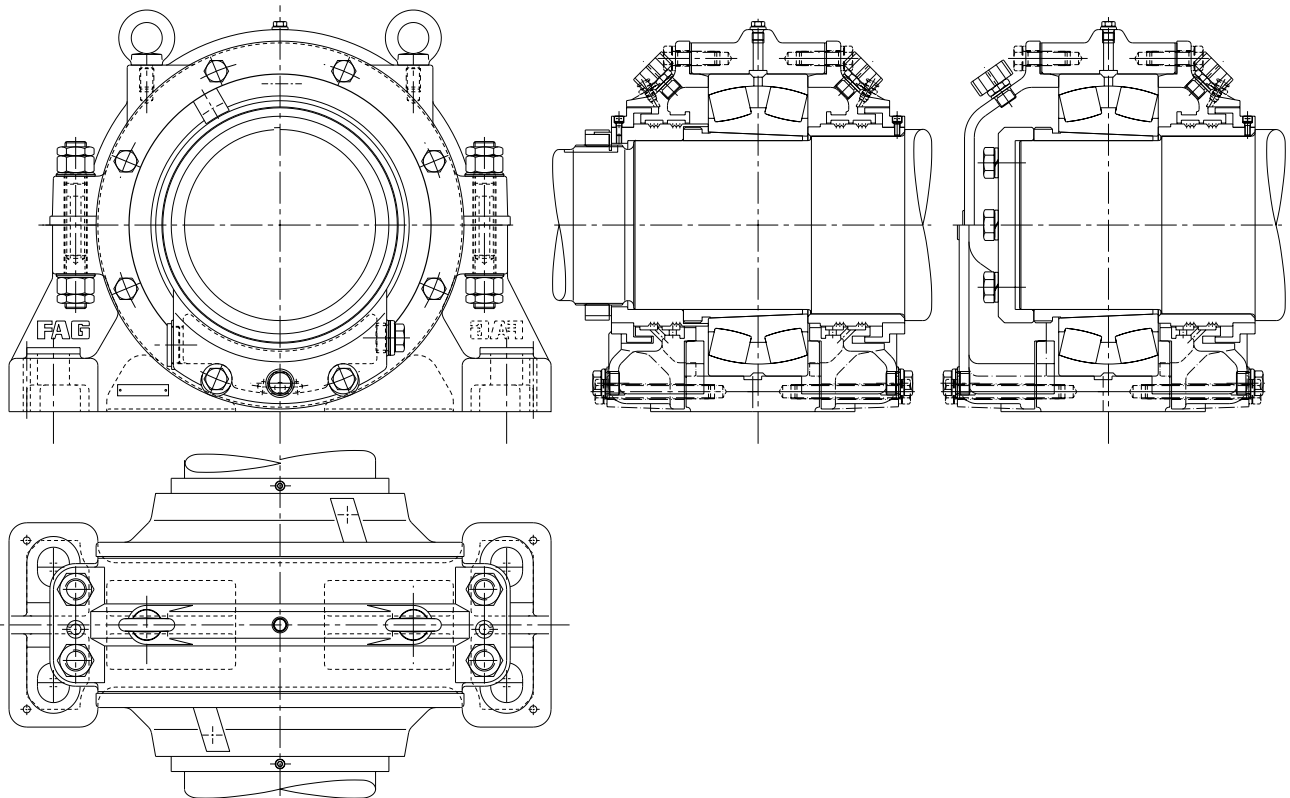

FAG Series Housings

Plummer block housings

NGO

Plummer block housings, split

Shaft diameters 80 to 160 mm

Type of lubrication: oil sump

Labyrinth seal

Standard housing-body material: GGG

Application: e.g. emergency power generating units

Housing sizes

Bearing sizes (spherical roller bearings)

NGO2216 to NGO2232

22216E to 22232E

FAG publication:

Dimension sheet

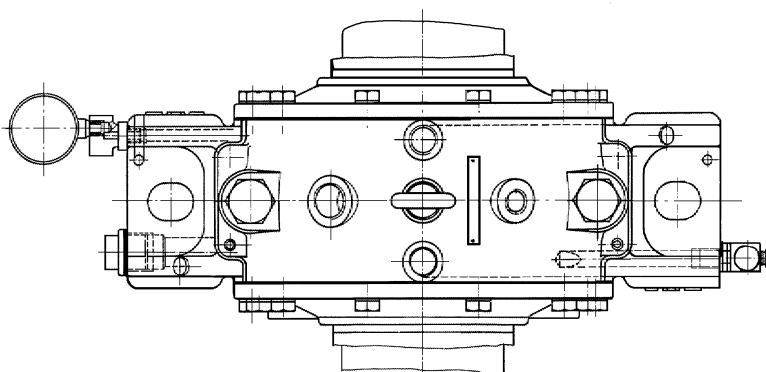
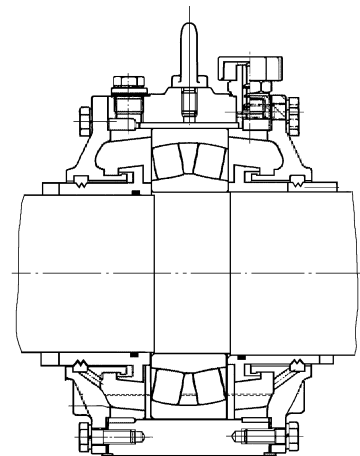
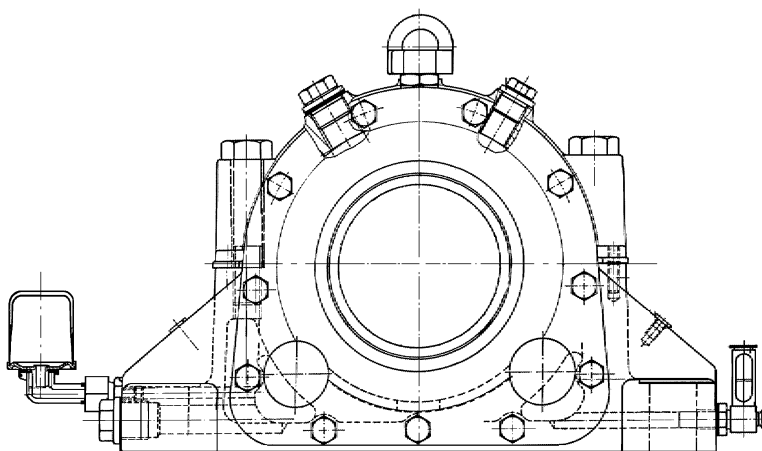

FAG Series Housings

Plummer block housings

PM

Plummer block housings, split

Shaft diameters 115 to 670 mm

Type of lubrication: oil sump (oil circulation possible after conversion)

Labyrinth seal

Standard housing-body material: GG

Application: e.g. paper machines

Housing sizes

Type of lubrication: oil sump (oil circulation possible after conversion)

PM3026 to PM30/710

23026ESK to 230/710BK

FAG publication:

Publ. Nr. WL 13 104 DA

CAD files in existence for some housings

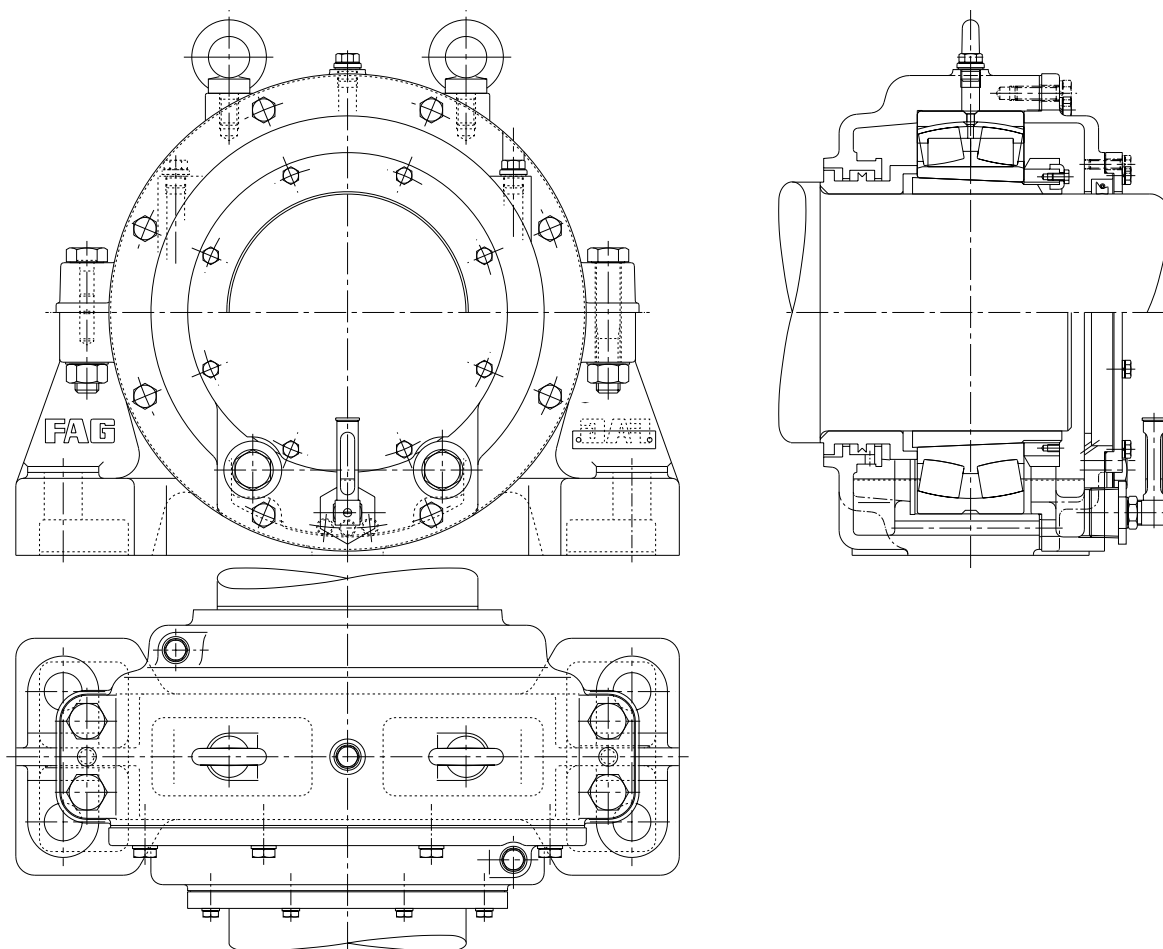

FAG Series Housings

Plummer block housings

PMD

Plummer block housings, split (locating bearings)

Shaft diameters 180 to 300 mm

Type of lubrication: oil circulation (oil sump with additional, external oil tank)

Gap-type seal with oil flinger edges

Standard housing-body material: GG

Application: e.g. paper machines

Housing sizes

Bearing sizes (spherical roller bearings with tapered bore)

PMD3136 to PMD3160

23136ESK to 23160BK

FAG publication:

TI No. WL 13-1 E-D

CAD files in existence

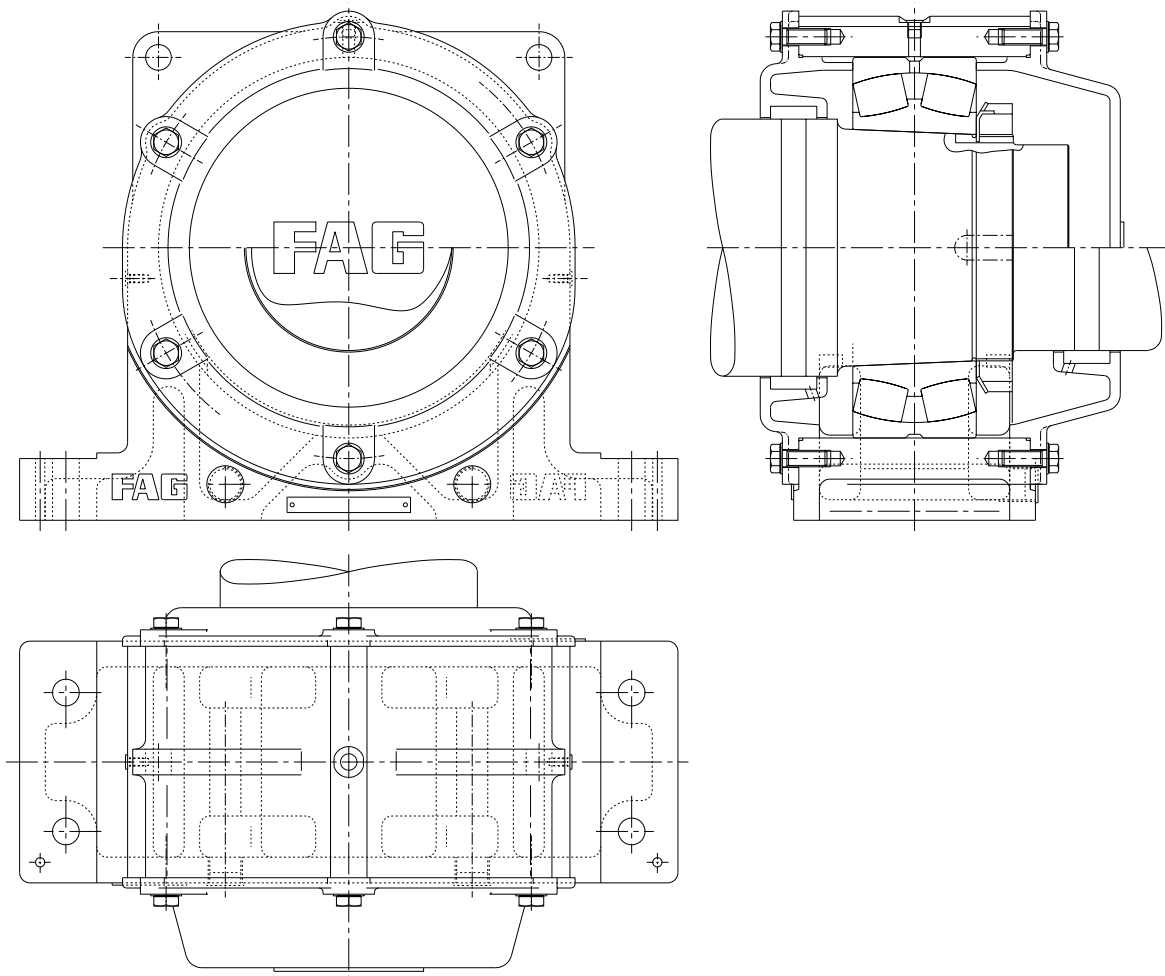

FAG Series Housings

Plummer block housings

PMDR

Plummer block housings, non-split (floating bearings)

Shaft diameters 180 to 300 mm

Type of lubrication: oil circulation (oil sump with additional, external oil tank)

Gap-type seal with oil flinger edges

Standard housing-body material: GG

Application: e.g. paper machines

Housing sizes

Bearing sizes (spherical roller bearings with tapered bore)

PMDR3136 to PMDR3160

23136ESK to 23160BK

FAG publication:

TI No. WL 13-1 E-D

CAD files in existence

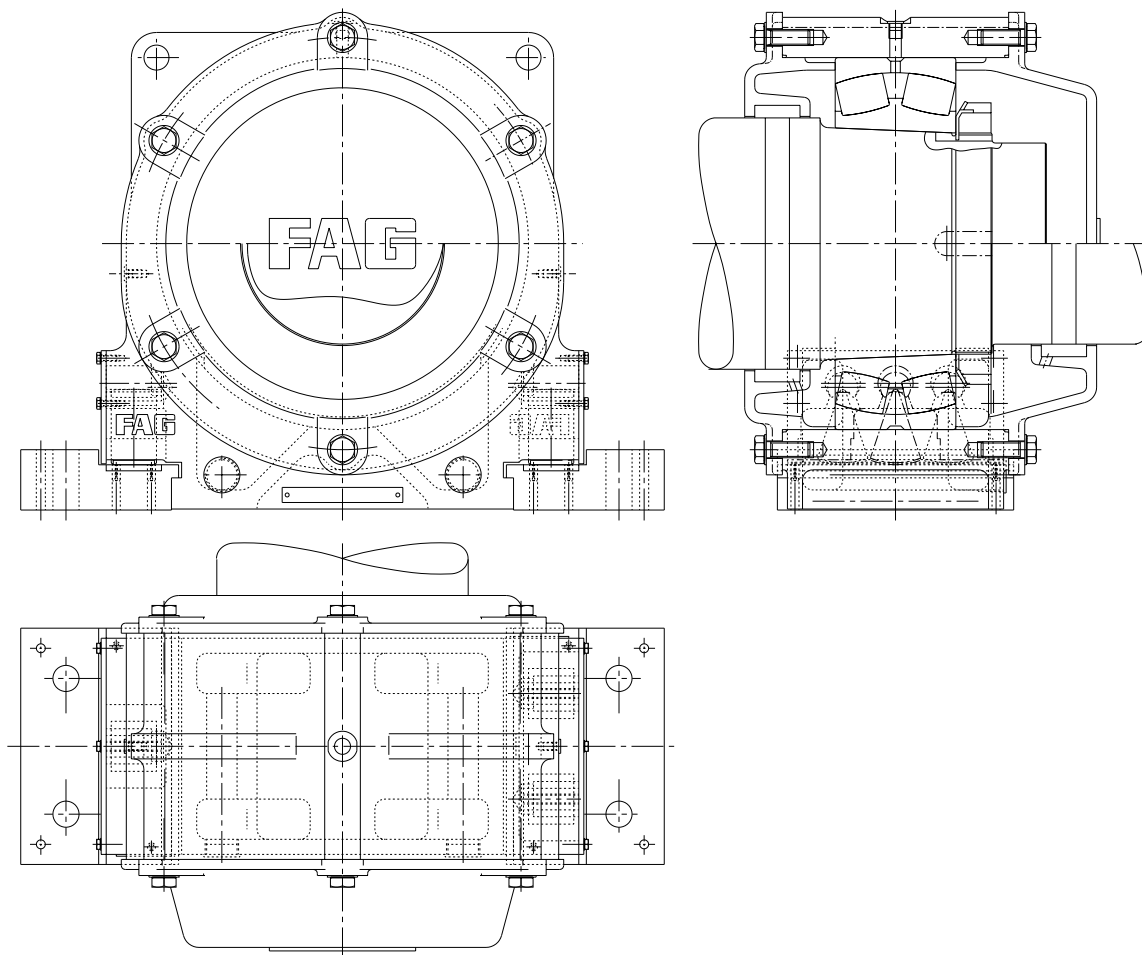

FAG Series Housings

Plummer block housings

RA

Plummer block housings, split

Shaft diameters 135 to 480 mm

Type of lubrication: grease

Labyrinth seal

Standard housing-body material: GG

Application: e.g. pinion drives

Housing sizes

RA3028 to RA30/500

RA3940 to RA39/500

RA3028AH to RA30/500AH

RA3940AH to RA39/500AH

Bearing sizes (spherical roller bearings)

23028ES to 230/500B

23940 to 239/500

23028ESK to 230/500BK

23940K to 239/500K

(bearings with
cylindrical bove)

(bearings with tapered bove
and withdrawal sleeve)

FAG publication:

Dimension sheet

CAD files in existence for some housings

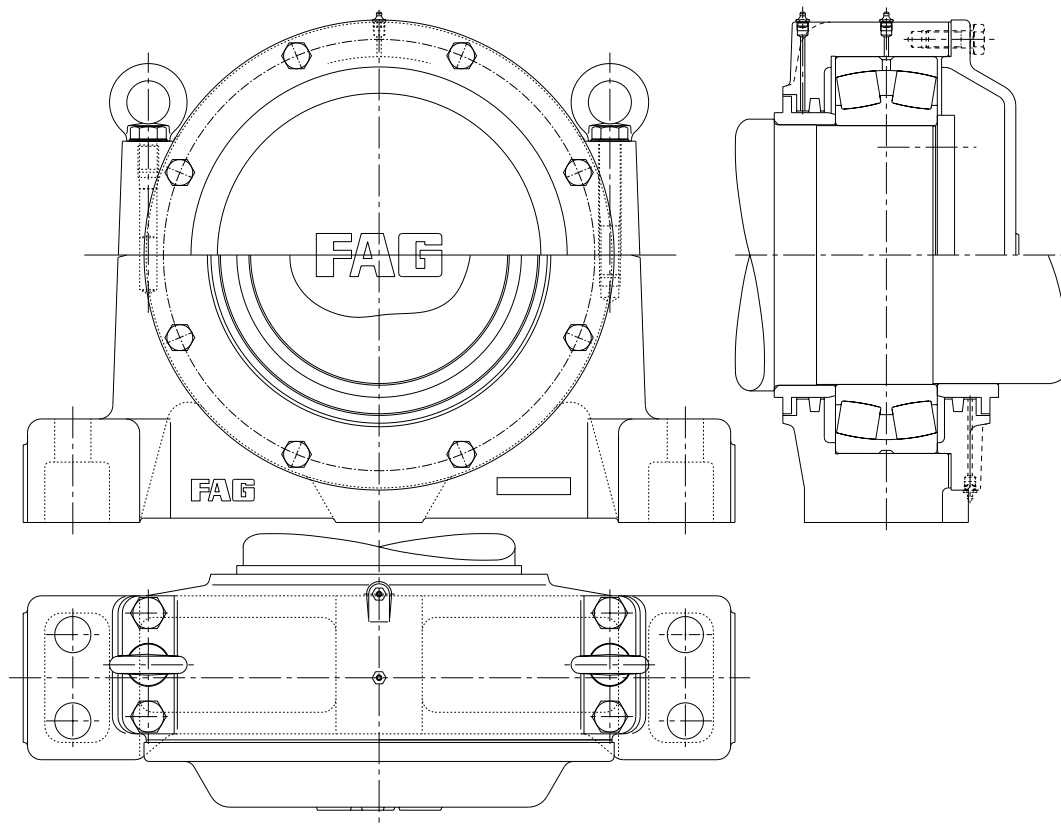

FAG Series Housings

Plummer block housings

RLE

Plummer block housings, split

Shaft diameters 100 to 500 mm

Type of lubrication: grease

Labyrinth seal

Standard housing-body material: GG

Application: e.g. support rollers

Housing sizes

RLE4122 to RLE41/500

RLE4122AH to RLE41/500AH

Bearing sizes (spherical roller bearings)

24122ES to 241/500B

24122ESK30 to 241/500BK30

(bearings with cylindrical bore)

(bearings with tapered bore
and withdrawal sleeve)

FAG publication:

Dimension sheet

CAD files in existence for some housings

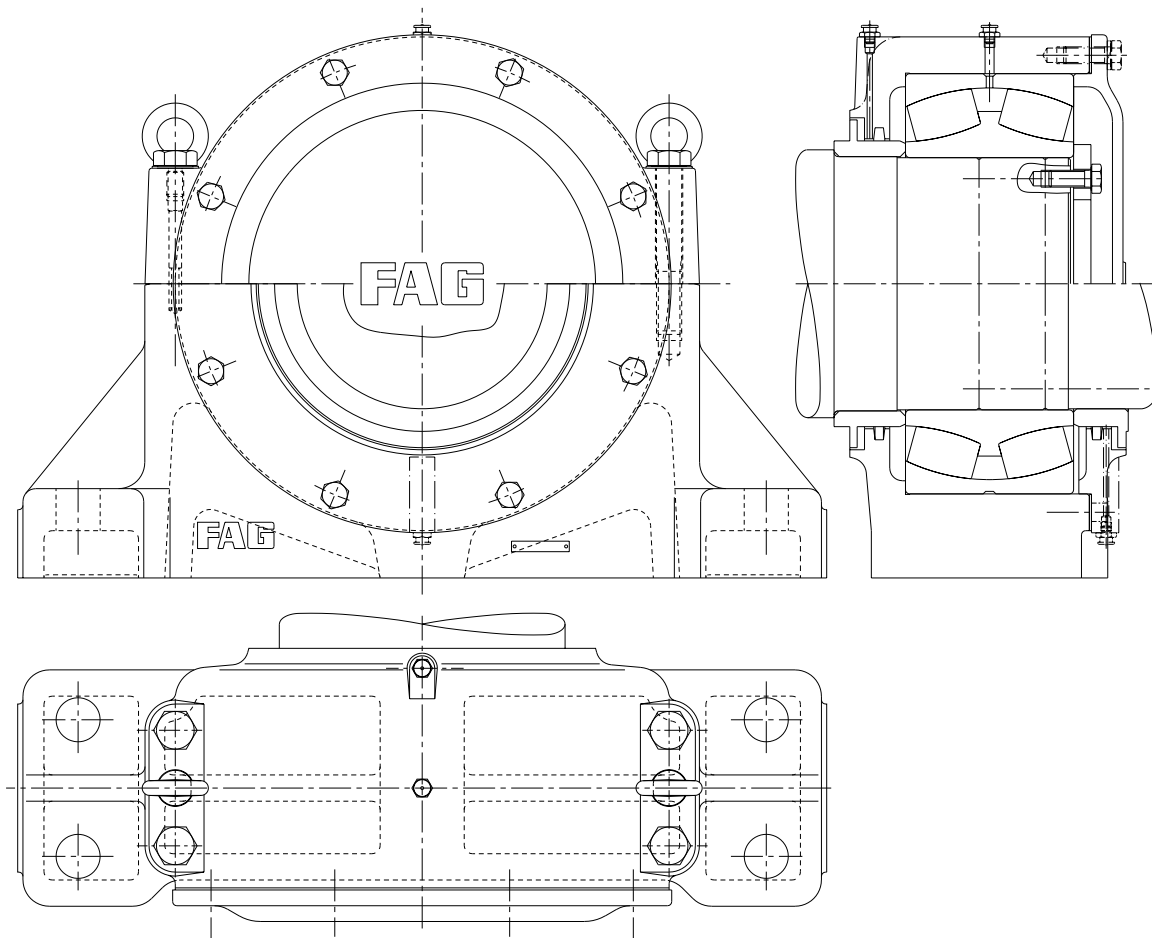

FAG Series Housings

Plummer block housings

S30

Plummer block housings, split

Shaft diameters 110 to 450 mm

Main dimensions standardized in ISO 113

Type of lubrication: grease

Felt seal

Standard housing-body material: GG

Application: e.g. general machine construction

Housing sizes

Bearing sizes (spherical roller bearings with tapered bore and adapter sleeve)

S3024K to S3096K

23024ESK to 23096K

FAG publication:

Catalogue WL 41 520/3 EA

CAD files in existence for some housings

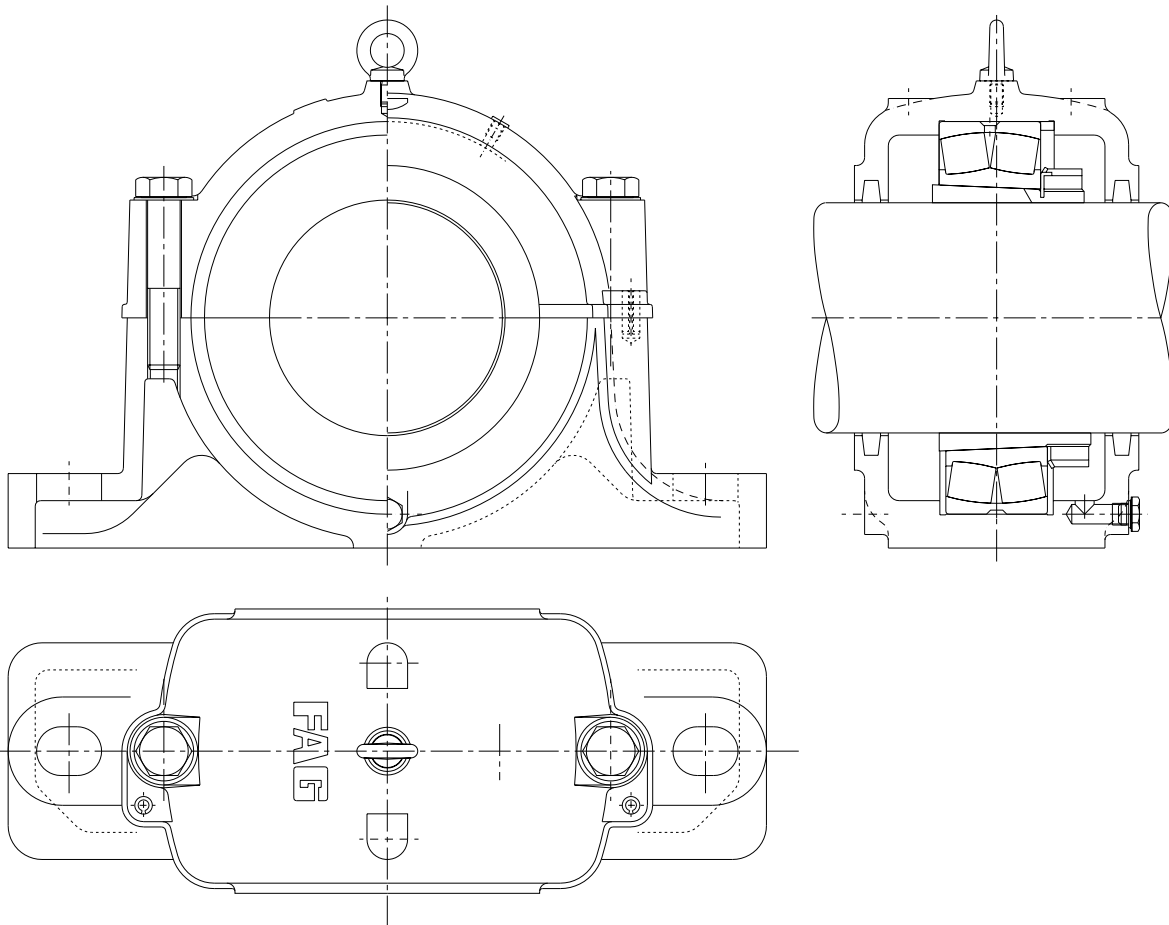

FAG Series Housings

Plummer block housings

S39

Plummer block housings, split
Shaft diameters 110 to 380 mm
Type of lubrication: grease
Felt seal
Standard housing-body material: GG
Application: e.g. general machine construction

Housing sizes

Bearing sizes (spherical roller bearings with tapered bore and adapter sleeve)

S3924K to S3980K

23924SK to 23980BK

FAG publication:
Dimension sheet

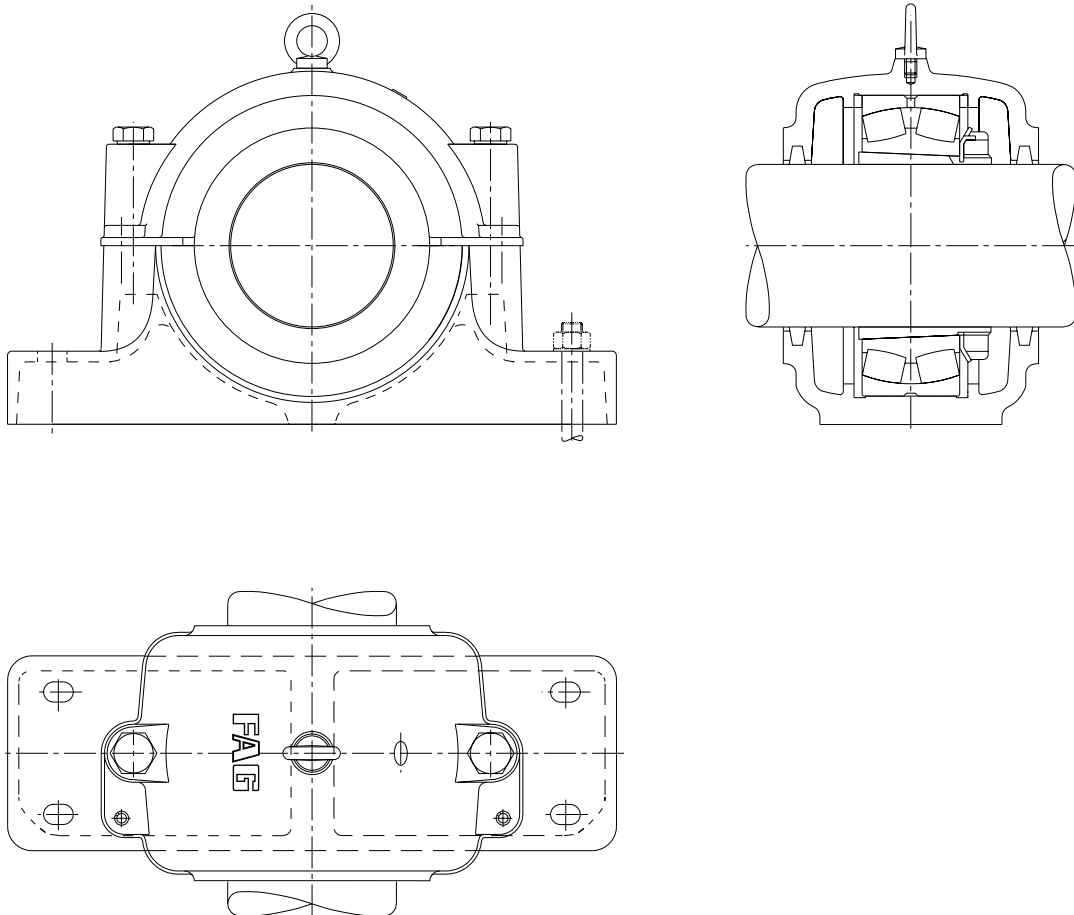

FAG Series Housings

Plummer block housings

SD

Plummer block housings, split

Shaft diameters 135 to 320 mm

Type of lubrication: grease

Felt seal

Standard housing-body material: GG

Application: e.g. general machine construction

Housing sizes

Bearing sizes (spherical roller bearings)

SD530 to SD564

SD630 to SD656

SDN230 to SDN264

SDN330 to SDN356

22230EK to 22264K

22330EDK to 22356K

22230E to 22264

22330ED to 22356

(bearings with tapered bore
and adapter sleeve)

(bearings with cylindrical
bore)

FAG publication:

Dimension sheet

CAD files in existence for some housings

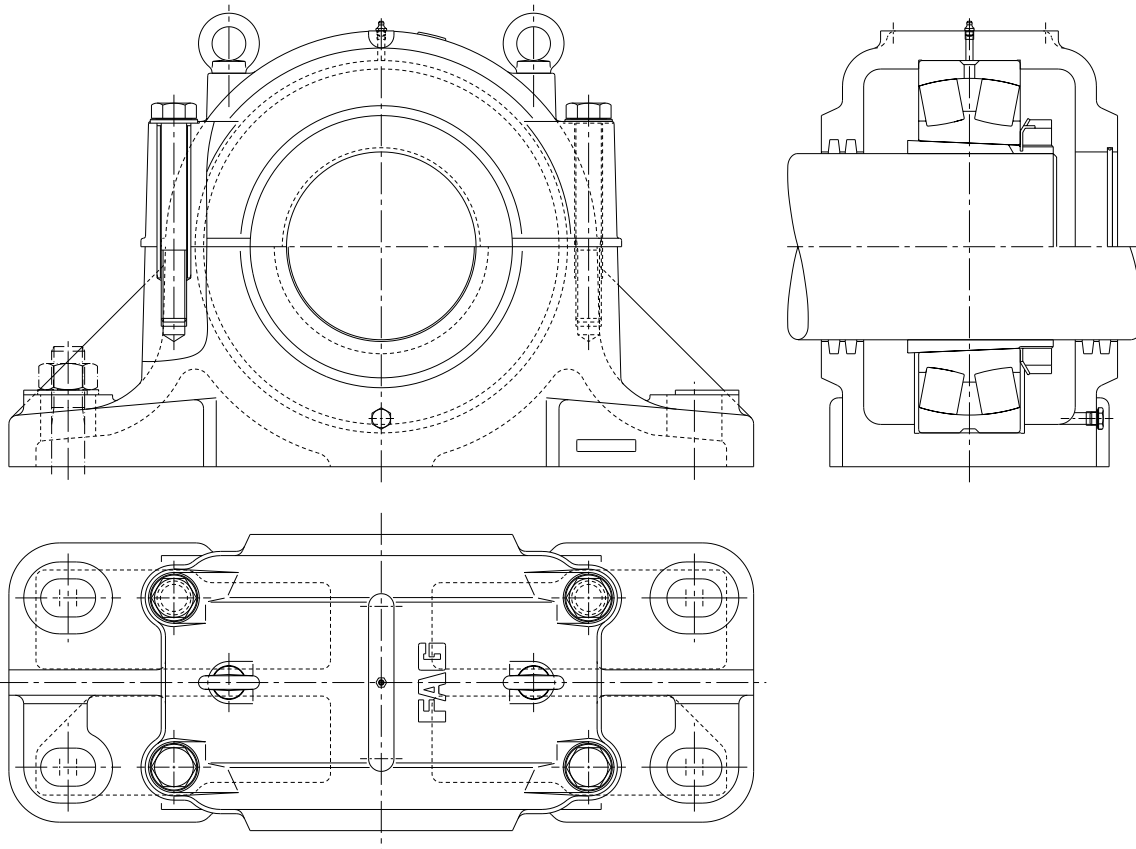

FAG Series Housings

Plummer block housings

SD31

Plummer block housings, split

Shaft diameters 150 to 450 mm

Typ of lubrication: grease

Labyrinth seal

Standard housing-body material: GG

Application: e.g. general machine construction

Housing sizes

Bearing sizes (spherical roller bearings with tapered bore and adapter sleeve)

SD3134TS to SD3196TS

23134ESK to 23196K

FAG publication:

Catalogue WL 41 520/3 EA

CAD files in existence for some housings

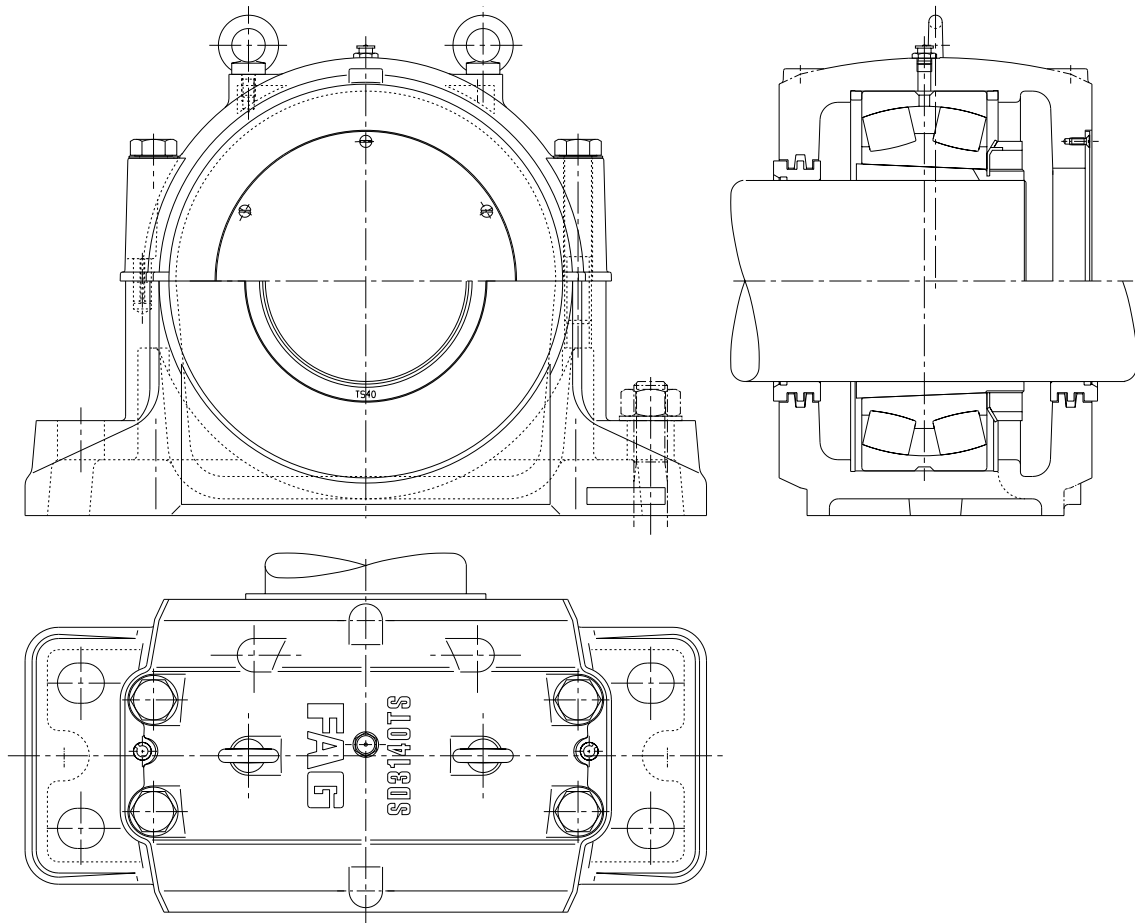

FAG Series Housings

Plummer block housings

SDK

Plummer block housings, split

Shaft diameters 320 to 450 mm

Type of lubrication: grease

Labyrinth seal

Standard housing-body material: GG

Application: e.g. general machine construction

Housing sizes

Bearing sizes (spherical roller bearings with tapered bore)

SDK3168TS to SDK3196TS

23168BK to 23196K

FAG publication:

Dimension sheet

CAD files in existence for some housings

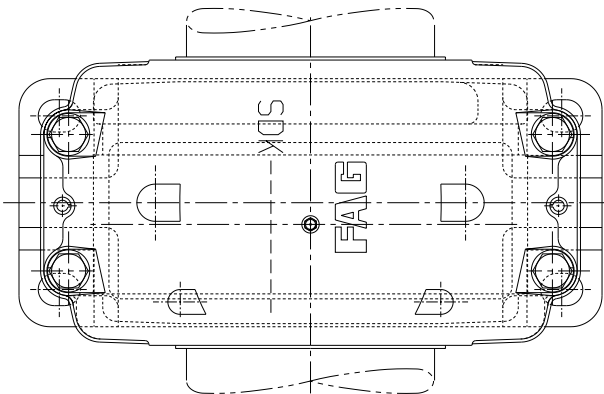
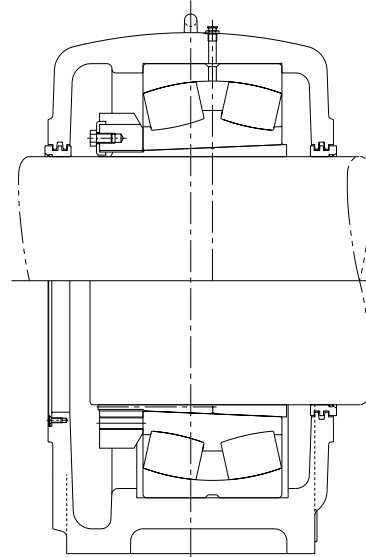
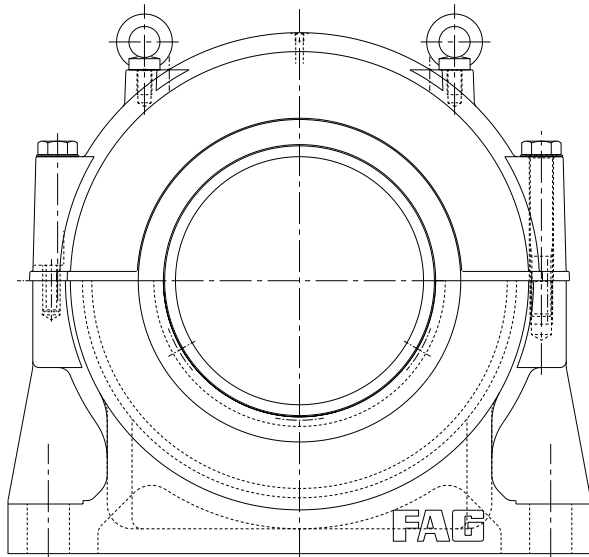

FAG Series Housings

Plummer block housings

SNV

Plummer block housings, split

Shaft diameters 20 to 160 mm

Main dimensions standardized in ISO 113 and DIN 736 to 739

Type of lubrication: grease and oil (oil sump and circulation)

Two-lip seal DH, or optionally labyrinth seal TSV, felt seal FSV, combined seal TCV

Standard housing-body material: GG

Application: e.g. general machine construction

Housing sizes

Bearing units

SNV052 to SNV340

21305E to 21322E (spherical roller bearings)
22205E to 22232E (spherical roller bearings)
22308E to 22332 (spherical roller bearings)
23218ES to 23232ES (spherical roller bearings)
1205 to 1222 (self-aligning ball bearings)
1305 to 1320 (self-aligning ball bearings)
2205 to 2220 (self-aligning ball bearings)
2305 to 2320 (self-aligning ball bearings)
20205 to 20232 (barrel roller bearings)
20305 to 20330 (barrel roller bearings)
also with tapered bore

FAG publication:

Catalogue WL 41 520/3 EA

Publ. No. WL 90 118/3 EA

CAD files in existence

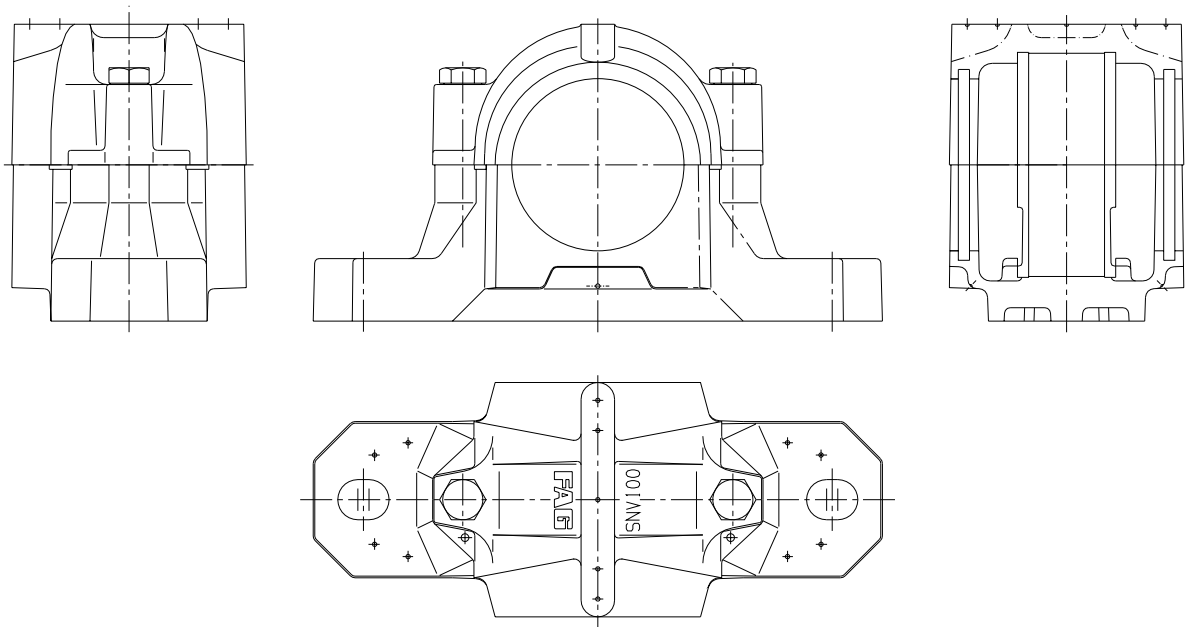

FAG Series Housings

Plummer block housings

TN

Plummer block housings, split

Shaft diameters 20 to 60 mm

Type of lubrication: grease

Gap-type seal or felt seal

Standard housing-body material: GG

Application: e.g. agricultural and construction machines

Housing sizes

Bearing sizes (self-aligning ball bearings)

TN204 to TN212

11204 to 11212

FAG publication:

Dimension sheet

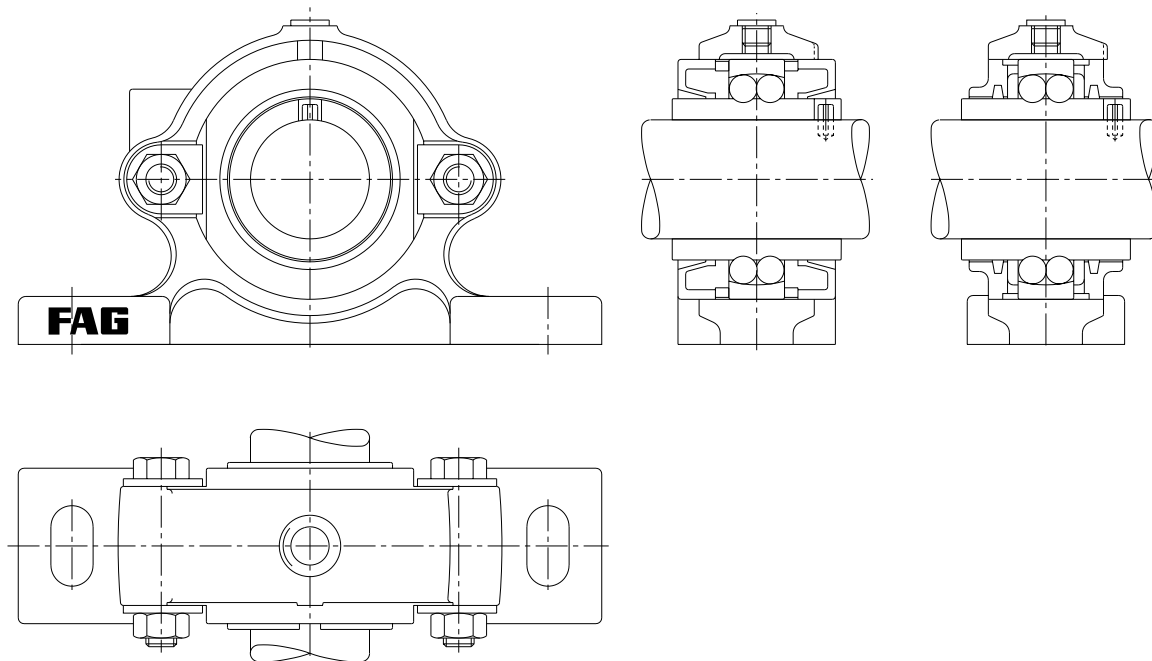

FAG Series Housings

Plummer block housings

TVN

Plummer block housings, non-split

Shaft diameters 20 to 90 mm

Type of lubrication: grease

Felt seal

Standard housing-body material: GG

Application: e.g. mine cars

Housing sizes

TVN204 to TVN218

TVN304 to TVN316

Bearing sizes

1204 to 1218 (self-aligning ball bearings)

20204 to 20218 (barrel roller bearings)

1304 to 1316 (self-aligning ball bearings)

20304 to 20316 (barrel roller bearings)

21304E to 21316E (spherical roller bearings)

FAG publication:

Dimension sheet

CAD files in existence for some housings

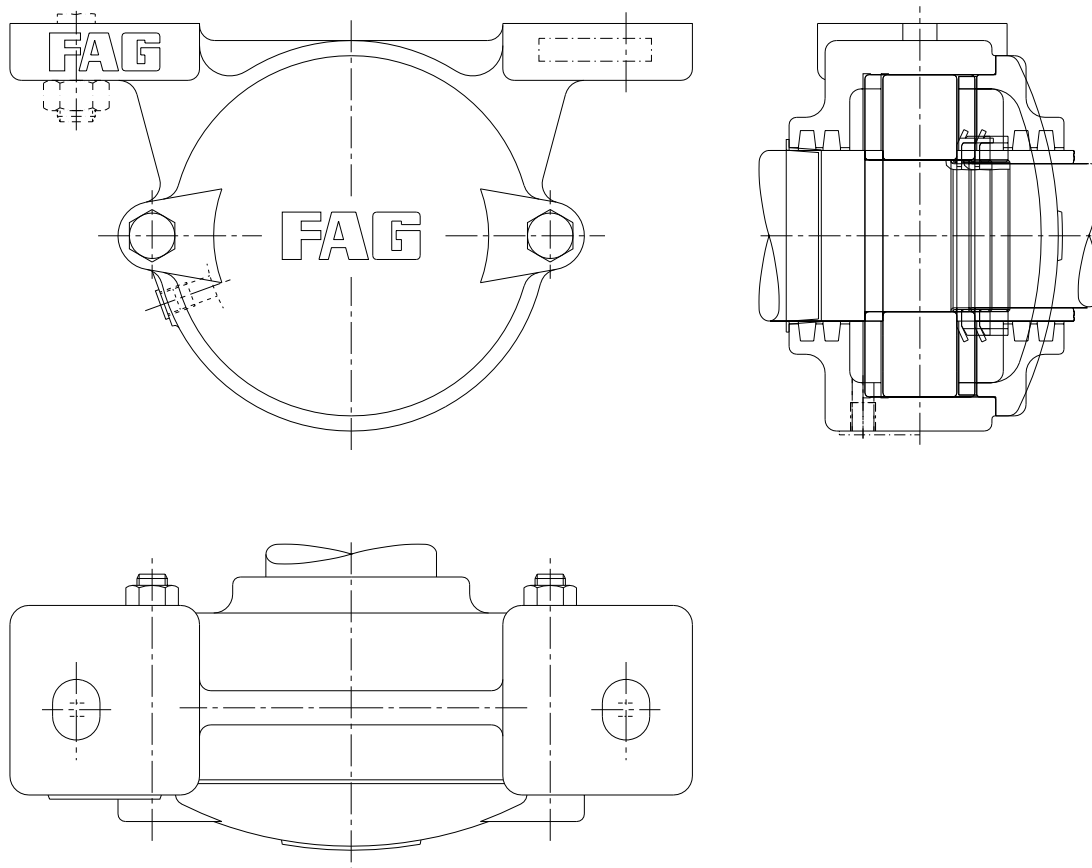

FAG Series Housings

Plummer block housings

VO

Plummer block housings, non-split

Shaft diameters 40 to 120 mm

Type of lubrication: oil sump

Gap-type seal with oil flinger edges

Standard housing-body material: GG

Application: e.g. ventilators

Housing sizes

Bearing sizes

VOS308 to VOS319

VOS220 to VOS224

NU308E/6308 to NU319E/6319

NU220E/6220 to NU224E/6224

(cylindrical roller bearing/deep groove ball bearing)

NU308E/2x7308B.UA to NU319E/2x7319B.UA

NU220E/2x7220B.UA to NU220E/2x7224B.UA

(cylindrical roller bearing/2 angular contact ball bearings)

VOB308 to VOB319

VOB220 to VOB224

VOG308 to VOG319

VOG220 to VOG224

2xNU308E/6308 to 2xNU319E/6319

2xNU220E/6220 to 2xNU224E/6224

(2 cylindrical roller bearings/deep groove ball bearing)

2xNU308E/QJ308 to 2xNU319E/QJ319

2xNU220E/QJ220 to 2xNU224E/QJ224

(2 cylindrical roller bearings/four point bearing)

2xNU308E/7308B to 2xNU319E/7319B

2xNU220E/7220B to 2xNU224E/7224B

(2 cylindrical roller bearings/angular contact ball bearing)

FAG publication: Dimension sheet

CAD files in existence for some files

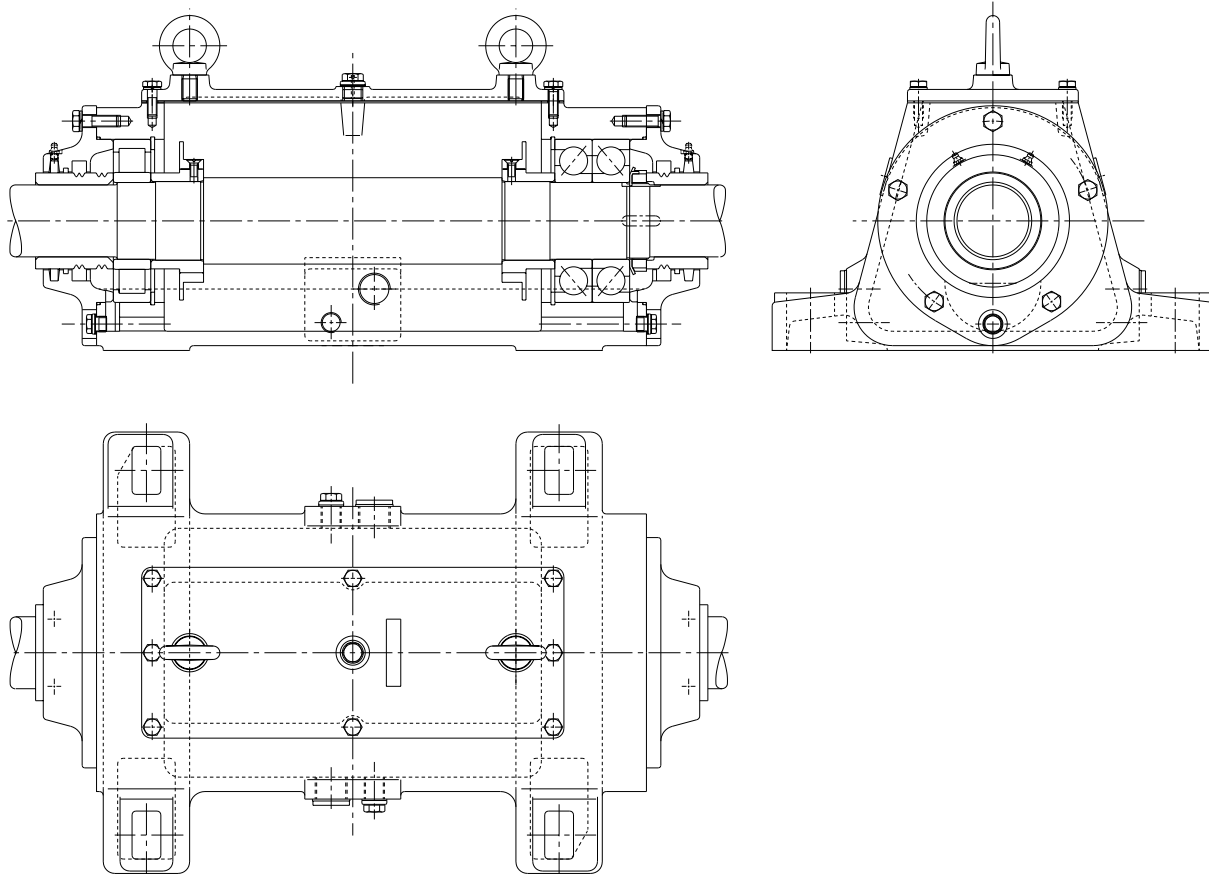

FAG Series Housings

Plummer block housings

VR3

Plummer block housings, non-split

Shaft diameters 25 to 120 mm

Type of lubrication: grease

Felt seal and V-ring seals

Standard housing-body material: GG

Application: e.g. ventilators, conveyors, belt gears, textile machines

| Plummer block units | Housing sizes | Bearing sizes |
|---------------------|------------------|---|
| VRE305A to VRE324A | VR305A to VR324A | 6305 to 6324 (2 deep groove ball bearings) |
| VRE305B to VRE324B | VR305A to VR324A | NJ305E to NJ324E/6305 to 6324 (cylindrical roller bearing/deep groove ball bearing) |
| VRE305C to VRE324C | VR305C to VR324C | NU305E to NU324E/2x7305B.UA to 2x7324B.UA (cylindrical roller bearing/2 angular contact ball bearings) |
| VRE305D to VRE324D | VR305D to VR324D | NU305E to NU324E/6305 to 6324 (cylindrical roller bearing/deep groove ball bearing) |
| VRE305E to VRE324E | VR305E to VR324E | 2xNU305E to 2xNU324E/6305 to 6324 (2 cylindrical roller bearings/deep groove ball bearing) |
| VRE305F to VRE316F | VR305F to VR316F | 6305 to 6316 (2 deep groove ball bearings) |

FAG publications: Catalogue WL 41 520/3 EA, Publ. No. WL 90 121/2 EA

CAD files in existence for some housings

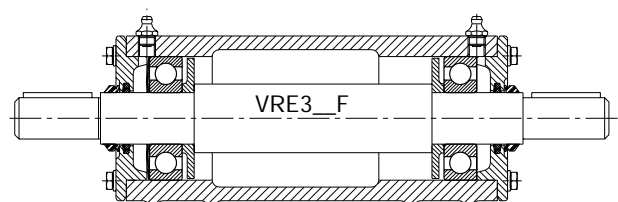
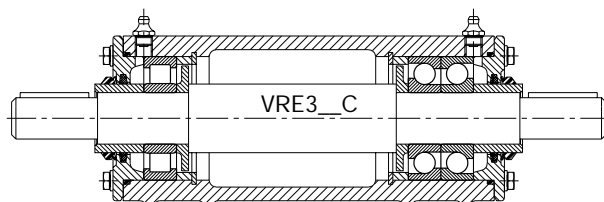
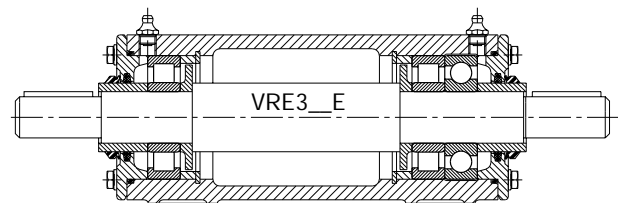
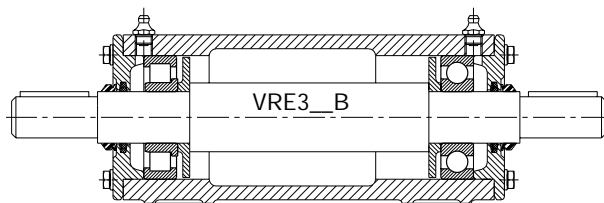
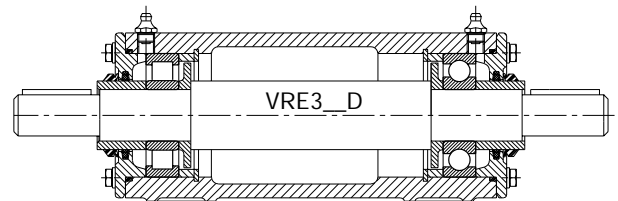
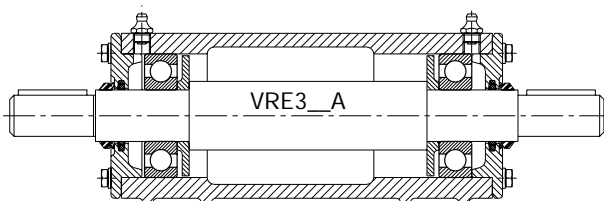

FAG Series Housings

Flanged housings

F112

Flanged housings

Shaft diameters 20 to 60 mm

Type of lubrication: grease

Gap-type seal or felt seal

Standard housing-body material: GG

Application: e.g. general machine construction

Housing sizes

Bearing sizes (self-aligning ball bearings)

F11204 to F11212

11204 to 11212

FAG publication:

Catalogue WL 41 520/3 EA

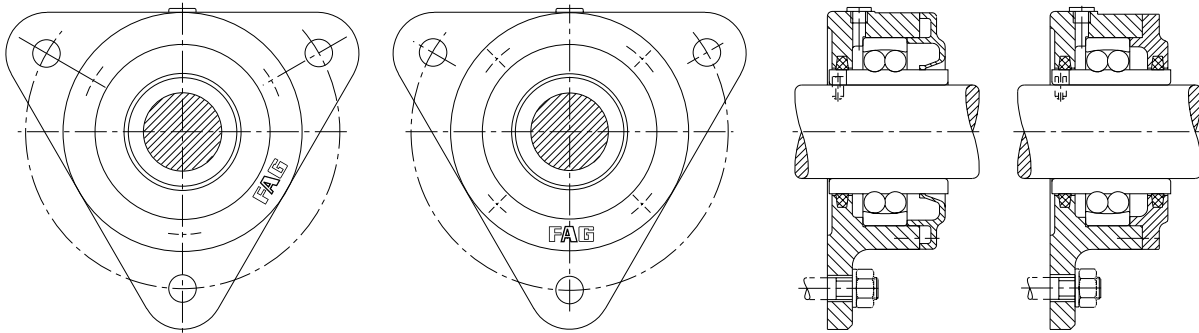

FAG Series Housings

Flanged housings

F5

Flanged housings

Shaft diameters 20 to 100 mm

Type of lubrication: grease

Felt seal

Standard housing-body material: GG

Application: e.g. general machine construction

Housing sizes

Bearing sizes

F505 to F522

1205K to 1222K (self-aligning ball bearings)

2205K to 2222K (self-aligning ball bearings)

20205K to 20222K (barrel roller bearings)

22205EK to 22222EK (spherical roller bearings)

FAG publication:

Catalogue WL 41 520/3 EA

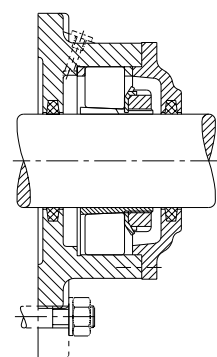
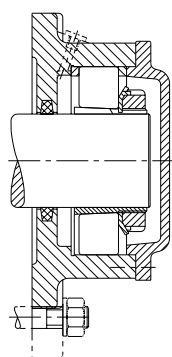
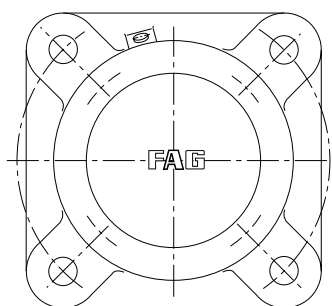
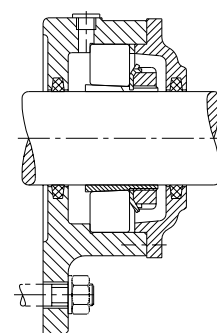
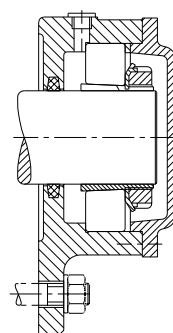
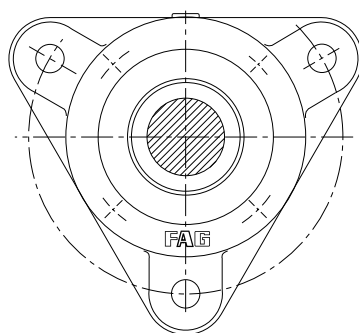
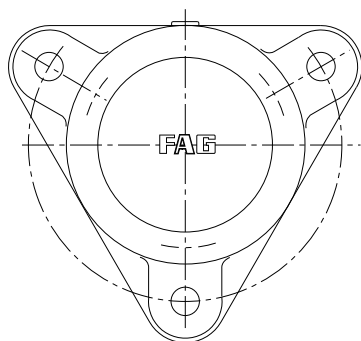

FAG Series Housings

Flanged housings

FER

Flanged housings

Shaft diameters 100 to 400 mm

Type of lubrication: grease

Labyrinth seal

Standard housing-body material: GGG

Application: e.g. big electric machines

Housing sizes

FERS020 to FERS080
FERS220 to FERS280
FERS320 to FERS380
FERB020 to FERB080
FERB220 to FERB280
FERB320 to FERB380

Bearing sizes

NU1020 to NU1080 (cylindrical roller bearings)
NU220E to NU280 (cylindrical roller bearings)
NU320E to NU380 (cylindrical roller bearings)
NU1020 to NU1080/6020 to 6080 (cylindrical roller bearing/deep groove ball bearing)
NU220E to NU280/6220 to 6280 (cylindrical roller bearing/deep groove ball bearing)
NU320E to NU380/6320 to 6380 (cylindrical roller bearing/deep groove ball bearing)

FAG publication:

Publ. No. WL 01 101/4 EA

CAD files in existence for some housings

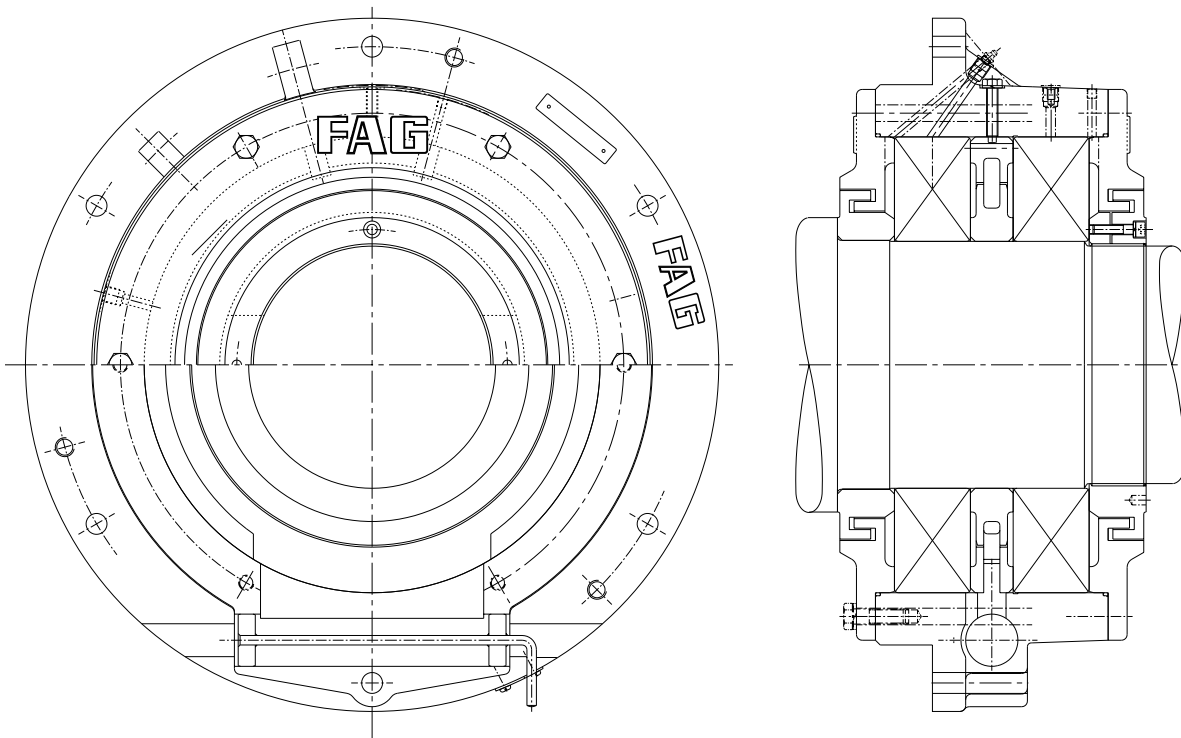

FAG Series Housings

Take-up housings

SPA

Take-up housings, non-split

Shaft diameters 45 to 400 mm

Type of lubrication: grease

Labyrinth seal (on request also Taconite seal)

Standard housing-body material: GS

Application: e.g. belt conveyors

Housing sizes

SPA2211K to SPA2228K

SPA3028K to SPA3056K

SPA3132K to SPA3176K

SPA3222K to SPA3284K

Bearing sizes (spherical roller bearings with tapered bore and adapter sleeve)

22211EK to 22228EK

23028ESK to 23056BK

23132ESK to 23176K

23222ESK to 23284BK

FAG publication:

Dimension sheet

CAD files in existence

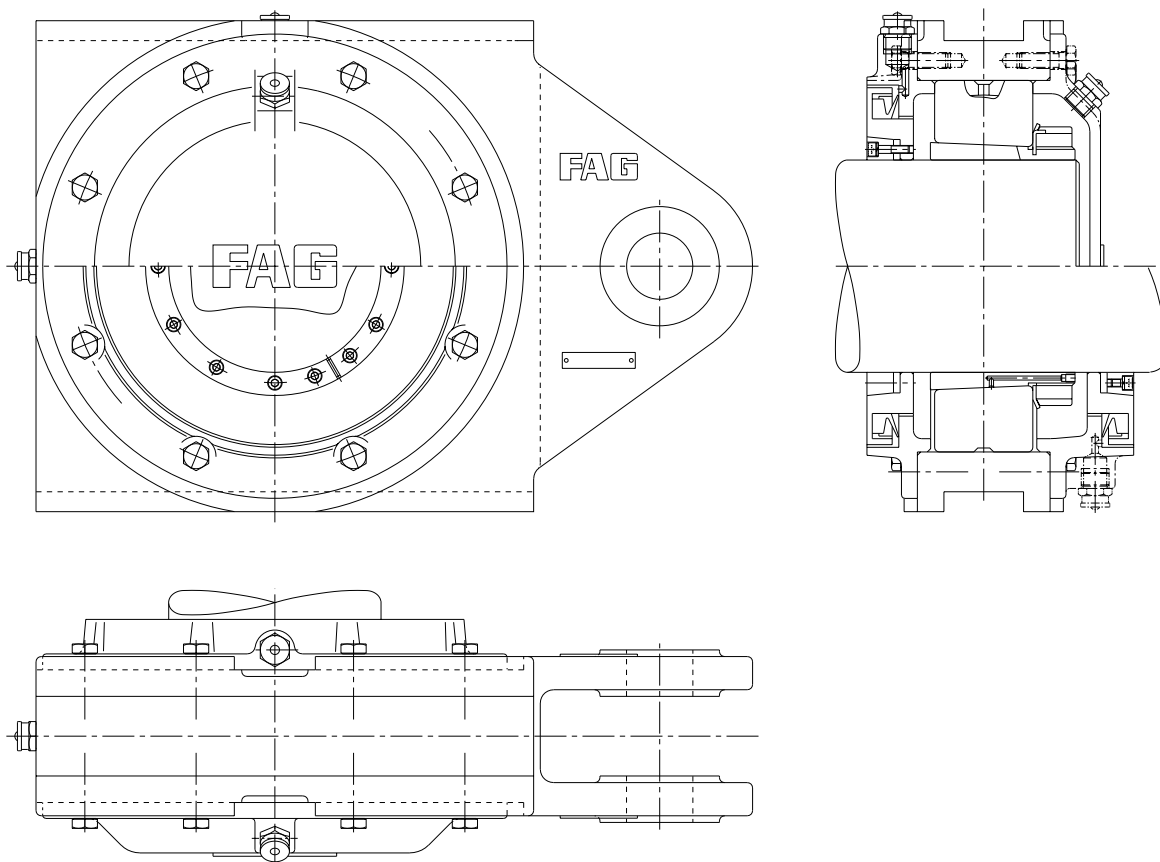

FAG OEM und Handel AG

A company of the FAG Kugelfischer Group

Postfach 12 60 · D-97419 Schweinfurt

Tel. +49-9721 / 91-0

Fax +49-9721 / 91 34 35

www.fag.com

e-mail: gehaeuse_k@fag.com

FAG Series Housings

Every care has been taken to ensure the correctness of the information contained in this publication but no liability can be accepted for any errors or omissions. We reserve the right to make changes in the interest of technical progress.

© by FAG 2001 · This publication or parts thereof may not be reproduced without our permission.

TI No. WL 90-30 E · 97/2/01 · Printed in Germany by Weppert GmbH & Co. KG, Schweinfurt