

FAG



FAG Equipment and Services for the Mounting and Maintenance of Rolling Bearings

For increased operational reliability of rolling bearing arrangements

SCHAEFFLER GROUP
INDUSTRIAL

About this catalogue

This catalogue is aimed principally at maintenance managers responsible for plants in which rolling bearings and other rotating machine components play a critical role in determining the quality of products and processes.

Maintenance managers are responsible for the maintenance and production process. They must be able to rely every day on the quality of their tools and the expertise of their service providers.

FAG Industrial Services (F'IS) therefore offers high quality products, services and training. This catalogue gives a complete guide to the range on offer from F'IS.

F'IS employees worldwide will be pleased to help you select the ideal products, services and training for your needs.

Hans-Willi Kessler,
Bernd Geropp and
Armin Kempkes
Management of
FAG Industrial Services



Questions and ideas on this catalogue
should be sent to:

Schaeffler KG

Postfach 1260 · 97419 Schweinfurt (Germany)

Georg-Schäfer-Strasse 30 · 97421 Schweinfurt (Germany)

Service Hotline:

Telephone: +49 2407 9149-99

E-mail: info@fis-services.com

www.fis-services.com

FAG Industrial Services – Competence in maintenance

FAG Industrial Services

FAG Industrial Services GmbH (F'IS), headquartered in Herzogenrath near Aachen, is an independent company that takes responsibility for the worldwide service business of Schaeffler Group Industrial covering the brands INA and FAG. The goal of F'IS is to help customers to reduce maintenance costs, optimise plant availability and prevent unforeseen machine downtimes. The services are provided regardless of the brand of the machine components used. F'IS is therefore **the** specialist contact for the maintenance of rotating components. In order to provide the qualified and rapid supply of F'IS products,

services and training to customers worldwide, F'IS has specialist centres around the world. All F'IS employees worldwide undergo a comprehensive training programme and are audited regularly. This ensures that F'IS services throughout the world comply with a uniformly high standard of quality. Since each customer has a different set of requirements, F'IS offers concepts individually tailored to the customer. The quality requirements are strongly influenced by a long history of high precision rolling bearing manufacture. Each tool, accessory and grease in this catalogue has been subjected to intensive testing in practical use and is classified as being of high quality.

The F'IS range

F'IS has undertaken ongoing expansion of its range in recent years. It covers products, services and training in the areas of

- Mounting/Repair
- Lubrication
- Alignment
- Condition monitoring
- Maintenance management

The designation system of the INA and FAG brands has been harmonised. This catalogue contains, for the first time, the new ordering designations, which are currently only valid for Europe. Customers outside Europe are requested to continue using the old ordering designations (please see the comparison on page 109).

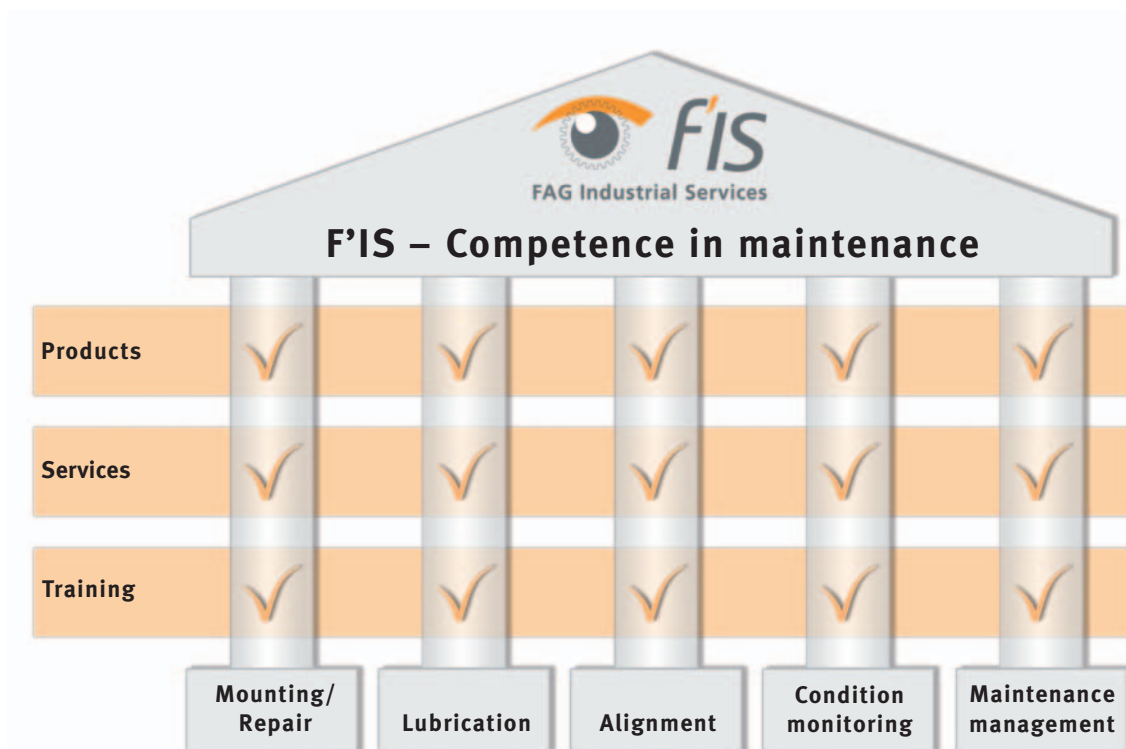

Contents

Products **7**

Mounting/Repair	8
Lubrication	43
Alignment	55
Condition monitoring	61
Maintenance management	71

Services **73**

Mounting/Repair	75
Lubrication	79
Corrective maintenance	80
Condition monitoring	81
Maintenance management	86

Training **91**

Mounting/Repair	93
Lubrication	95
Alignment	95
Condition monitoring	96
Maintenance management	99

























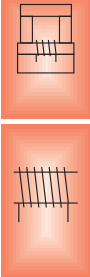





















Publications **103**







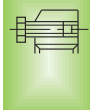







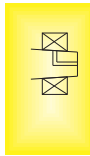



























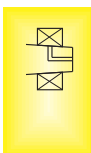

Index of FAG products **105**

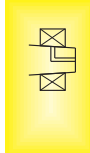
Comparison of ordering designations **109**

Tools for mounting and dismounting

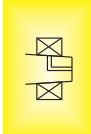
Overview

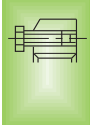
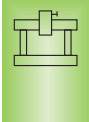
Bearing type	Bearing bore	Bearing size	Mounting				
			With heating				Without heating
 Deep groove ball bearings  Tapered roller bearings  Angular contact ball bearings  Barrel roller bearings  Four point contact bearings  Spherical roller bearings  Self-aligning ball bearings	Cylindrical	Small					
		Medium					
		Large					
 Cylindrical roller bearings  Needle roller bearings	Cylindrical	Small					
		Medium					
		Large					
 Thrust ball bearings  Angular contact thrust ball bearings  Cylindrical roller thrust bearings  Spherical roller thrust bearings	Cylindrical	Small					
		Medium					
		Large					
 Self-aligning ball bearings  Self-aligning ball bearings with adapter sleeve  Barrel roller bearings  Barrel roller bearings with adapter sleeve  Spherical roller bearings  Spherical roller bearings with adapter sleeve  Spherical roller bearings with withdrawal sleeve  Adapter sleeve  Withdrawal sleeve	Tapered	Small					 
		Medium					
		Large					
 Cylindrical roller bearings, double row	Tapered	Small					 
		Medium					
		Large					

	Hydraulic method	Dismounting		Hydraulic method	Symbols
		With heating	Without heating		
			  		 Induction heating device  Heating plate  Hot air cabinet  Heating cabinet  Oil bath  Induction heating device (coil)  Heating ring  Hammer and mounting sleeve
		 	 		 Hammer and mounting sleeve  Mechanical and hydraulic presses  Double hook wrench  Nut and hook wrench
			 		 Socket wrench  Nut and mounting screws  End cap  Hydraulic nut
 			  		 Hammer and drift  Extraction device  Hydraulic method
			   		

Products · Mounting/Repair

Mechanical mounting and dismantling 8

Mounting tool sets	8
Socket wrenches	9
Hook and pin wrenches	9
Mechanical extractors	12
Hydraulic extractors	15
Three-section extraction plates	17

Hydraulic mounting and dismantling 19

Hydraulic nuts	19
Mounting Manager	21
Overview of pressure generation devices	22
Oil injectors	24
Hand pump sets	25
High pressure pump	26
Hydraulic systems and units	27
Connectors, accessories	28

Thermal mounting and dismantling 31

Electric heating plates	31
Induction heating devices	31
Heating rings, heat conducting paste	34
Electric induction heating devices	35

Measurement and inspection 36

Feeler gauges	36
Taper gauges	36
Snap gauge	38
Enveloping circle gauges	39

Accessories 40

Transport and mounting tool	40
Gloves	41
Mounting paste	42
Anti-corrosion oil	42



Products · Mounting/Repair

Mechanical mounting and dismounting

Mounting tool sets

FAG mounting tool sets FITTING-TOOL-ALU-10-50 and FITTING-TOOL-STEEL-10-50

FAG mounting tool sets allow economical and secure mounting of rolling bearings up to 50 mm bore. They can also be used to easily mount sleeves, intermediate rings, seals and similar parts.

Where inner or outer rings with a tight fit are to be driven onto a shaft or into a housing bore respectively, this can be achieved by applying hammer blows to an appropriate mounting sleeve. This prevents the mounting forces from being transmitted through the rolling elements and raceways, which can lead to damage. The carefully matched FAG precision parts ensure that the forces are uniformly transmitted to the side faces of the bearing rings.

The FITTING.TOOL.ALU.SET10-50 includes mounting sleeves made from aluminium and mounting rings made from plastic. The parts are economical and easy to use. The steel mounting sleeves and steel mounting rings in the FITTING.TOOL.STEEL.SET10-50 give long wear-free operating life. These tools can also be used in combination with workshop power presses.

FAG mounting tool sets FITTING-TOOL-ALU-10-50 and FITTING-TOOL-STEEL-10-50

Included in delivery

Ordering designation

FITTING-TOOL-ALU-10-50

FITTING-TOOL-STEEL-10-50

Mounting rings For bearing bore	33 pieces 10–50 mm	33 pieces 10–50 mm
Outside diameter up to	110 mm	110 mm
Mounting sleeves	3 pieces	5 pieces
Hammer, recoilless	1 kg	0,7 kg
Dimensions of case	440×350×95 mm	370×320×70 mm
Mass of complete set	4,5 kg	21 kg
Also available as individual parts		

For detailed information, see
TPI WL 80-56.



Products · Mounting/Repair Mechanical mounting and dismounting

Socket wrenches and hook wrenches for mounting and dismounting

FAG socket wrench LOCKNUT-SOCKET...

For locknuts KM0 to KM20

Locknuts can be easily tightened and loosened on shafts, adapter sleeves and extraction sleeves using FAG socket wrenches LOCKNUT-SOCKET...

They require less space on the circumference of the nut than hook wrenches and allow the use of ratchets and torque wrenches. For increased reliability, socket wrenches should be secured using a locking pin and rubber washer. FAG socket wrenches therefore have a hole for the locking pin and a groove for the rubber washer. The locking pin and rubber washer are included in delivery.

Ordering example for FAG socket wrench, suitable for locknut KM5:
LOCKNUT-SOCKET-KM5

For detailed information, see
TPI WL 80-56.

FAG hook wrenches LOCKNUT-HOOK...

For locknuts KM0 to KM40

FAG hook wrenches of series LOCKNUT-HOOK... can be used to tighten and loosen locknuts on shafts, adapter sleeves and extraction sleeves.

FAG hook wrenches can be used to mount small bearings on tapered shaft seats, adapter sleeves or extraction sleeves.

Extraction sleeves can also be dismantled using FAG hook wrenches together with the extraction nuts.

Ordering example for FAG hook wrench, suitable for locknuts KM18, KM19, KM20:
LOCKNUT-HOOK-KM18-20

For detailed information, see
TPI WL 80-56.



Products · Mounting/Repair

Mechanical mounting and dismounting

Hook wrenches and pin wrenches for mounting and dismounting

FAG jointed hook wrenches LOCKNUT-FLEXIHOOK...

For locknuts KM1 to KM36 and precision locknuts ZM12 to ZM150 as well as ZMA15/33 to ZMA100/140

FAG jointed hook wrenches of series LOCKNUT-FLEXI-HOOK... can be used to tighten and loosen locknuts (precision locknuts) on shafts, adapter sleeves and extraction sleeves if no torque value is specified.

The joint allows one hook wrench of series LOCKNUT-FLEXI-HOOK... to be used for mounting or dismounting locknuts of various sizes.

Ordering example for FAG jointed hook wrench, suitable for locknuts KM14 to KM24:

LOCKNUT-FLEXIHOOK.KM14-24

For detailed information, see TPI WL 80-56.

FAG jointed pin wrenches LOCKNUT-FLEXIPIN...

For precision locknuts AM15 to AM90

FAG jointed pin wrenches of series LOCKNUT-FLEXI-PIN... can be used to tighten and loosen locknuts on shafts if no torque value is specified.

FAG jointed pin wrenches can be used to mount small bearings on tapered shaft seats.

Tightening is achieved by means of radially arranged holes.

Ordering example for FAG jointed pin wrench, suitable for locknuts AM35 to AM60:

LOCKNUT-FLEXIPIN.AM35-60

For detailed information, see TPI WL 80-56.

FAG jointed face wrenches LOCKNUT-FACEPIN...

For precision locknuts LNP017 to LNP170

FAG jointed face wrenches of series LOCKNUT-FLEXI-PIN... can be used to tighten and loosen precision locknuts on shafts if no torque value is specified.

FAG jointed face wrenches can be used to mount small bearings on tapered shaft seats.

Tightening is achieved by means of axially arranged holes.

Ordering example for FAG jointed face wrench, suitable for precision locknuts LNP017 to LPN025:

LOCKNUT-FACEPIN.LNP17-25

For detailed information, see TPI WL 80-56.



Products · Mounting/Repair Mechanical mounting and dismounting

Hook wrenches and pin wrenches for mounting and dismounting

FAG double hook wrenches

For locknuts KM5 to KM13

FAG double hook wrenches are intended for the mounting of self-aligning ball bearings with a tapered bore. They are available as kits, sets or individual wrenches.

FAG double hook wrench kits

LOCKNUT-DOUBLEHOOK...-KIT

include a case containing a double hook wrench, a torque wrench and a user manual.

The torque wrench allows a precisely defined tightening torque to be achieved at the start of the mounting operation.

FAG double hook wrench sets

LOCKNUT-DOUBLEHOOK...-SET

contain four or five double hook wrenches. The other items in the case are the same as in the kits.

Individual double hook wrenches

LOCKNUT-DOUBLEHOOK-KM5 to LOCKNUT-DOUBLEHOOK-KM13 are also available. Each double hook wrench is engraved with the torsion angles for the self-aligning ball bearings to be mounted using that particular wrench, so that the sliding distance and reduction in radial internal clearance can be precisely set.

For detailed information, see TPI WL 80-56.



Double hook wrench kits, e. g. LOCKNUT-DOUBLEHOOK-KM5-KIT and LOCKNUT-DOUBLEHOOK-KM13-KIT



Double hook wrench kits LOCKNUT-DOUBLEHOOK-KM5-8-SET and LOCKNUT-DOUBLEHOOK-KM9-13-SET



Double hook wrenches, e. g. LOCKNUT-DOUBLEHOOK-KM5 and LOCKNUT-DOUBLEHOOK-KM13

Products · Mounting/Repair

Mechanical mounting and dismounting

Mechanical extractors

Mechanical FAG extractors PowerPull

Mechanical extractors can be used to dismount small rolling bearings up to approx. 100 mm bore diameter that are located with a tight fit on a shaft or in a housing.

The bearing can be dismounted without damage if the extractor is

in contact with the tightly fitted bearing ring.

In mechanical FAG extractors, the extraction force is normally applied by means of a threaded spindle.

In addition to devices with two, three or four arms and a hydraulic pressure tool, we also offer special extraction devices.

For detailed information, see TPI WL 80-56.

Note:

For the dismounting of larger bearings, hydraulic extractors should be used (page 15).

Two-arm extractor 54

- For extraction of complete rolling bearings or tightly fitted inner rings as well as other parts, e.g. gears
- Grip width 80–350 mm, grip depth 100–250 mm

Available as set (stand with 6 extractors) or individually

Ordering designation:

PULLER54-SET
PULLER54-100
PULLER54-200
PULLER54-300
PULLER54-400
PULLER54-500
PULLER54-600

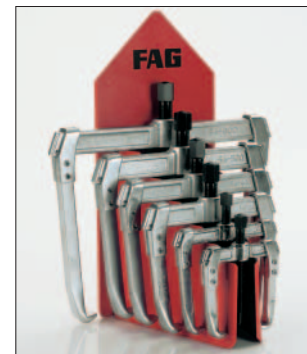

Two-arm bearing extractor 47

- For extraction of complete rolling bearings or tightly fitted inner rings
- Grip width 45 and 90 mm, grip depth 65 and 100 mm

Ordering designation:

PULLER47-100
PULLER47-200



Three-arm extractor 52

- For extraction of complete rolling bearings or tightly fitted inner rings
- Grip width 85–640 mm, grip depth 65–300 mm

Ordering designation:

PULLER52-085
PULLER52-130
PULLER52-230
PULLER52-295
PULLER52-390
PULLER52-640



Products · Mounting/Repair

Mechanical mounting and dismantling

Mechanical extractors

Hydraulic pressure tool 44

- For loosening of tightly fitted parts in conjunction with mechanical extractors
- Significant reduction in effort through generation of an axial force of 80 or 150kN, with a hydraulic return mechanism on the larger device

Ordering designation:

PULLER44-080

PULLER44-150



Ball bearing extractor 56

- For extraction of complete radial ball bearings
- For tightly fitted outer rings
- For bearings without radial access
- Three sets with different claws available

Ordering designation:

PULLER56-020-SET

PULLER56-120-SET

PULLER56-220-SET



Special bearing extractor 64

- For radial bearings (deep groove ball bearings, self-aligning ball bearings as well as cylindrical roller, tapered roller and spherical roller bearings); please state the bearing manufacturer.
- For tight fit of inner ring or outer ring

Ordering example for deep groove ball bearing 6000:

Base device **PULLER64-400** +

collet **PULLER64.COLLET-A-6000**

Ordering example for tapered roller bearing pair 30203-A in X arrangement:

Base device **PULLER64-400** +

collet **PULLER64.COLLET-B-30203A**

+ collet **PULLER64.COLLET-C-30203A**



Products · Mounting/Repair

Mechanical mounting and dismantling

Mechanical extractors

Extraction device 49

- For all rolling bearing types. For extraction of complete rolling bearings or tightly fitted inner rings. The extractor and the separator device are available in five sizes with grip widths of up to 210 mm.
- Principally for cases in which the inner ring is adjacent to a shoulder on the shaft without extraction slots. Good radial access to the bearing position is required.

Ordering designation:

PULLER49-100-060
PULLER49-100-075
PULLER49-200-115
PULLER49-300-150
PULLER49-400-210



Internal extractor 62

- For deep groove ball bearings and angular contact ball bearings. The internal extractor set comprises nine extractors and can be used on bearings with a bore of 5 mm up to approx. 70 mm.
- For tightly fitted outer rings.
- The inner ring bore must be free.

Ordering designation (nine internal extractors with two countersupports in a rigid metal case):

PULLER62-SET

The nine internal extractors can also be ordered individually.



Internal extractor

PULLER-INTERNAL10/100-SET

- For standard deep groove ball bearings. The set, containing 6 sets of extraction legs and 2 threaded spindles, can be used on bores from 10 to 100 mm.
- For tightly fitted outer rings.
- No dismantling of shaft.

Ordering designation

(six sets of extraction legs and two threaded spindles in a toolbox):

PULLER-INTERNAL10/100-SET

The individual parts can also be ordered individually.



Products · Mounting/Repair

Mechanical mounting and dismounting

Hydraulic extractors

Hydraulic FAG extractors PowerPull SPIDER

The hydraulic FAG extractors PowerPull SPIDER are used where higher extraction forces are required.

The ten extractor sizes have a range of extraction forces from 40 to 400 kN, covering a very wide range of possible applications.

These devices allow rolling bearings, gears, sleeves and many other shrink fitted parts to be quickly and easily dismantled. In addition, the low mass of the extractors mean that they can be used in any position.

If necessary, greater grip depth can be achieved through the use of extra long extraction arms (available as accessories).

For protection of operators, the extractors SPIDER 40 to 80 have a safety grid. All larger hydraulic extractors are supplied with a transparent, very tough safety cover. The cover can be easily placed around the workpiece or tool and secured using velcro strips.

For detailed information, see TPI WL 80-56.

Overview of significant advantages

- Safety grip allows pumping while wearing industrial gloves
- Optimum operating position due to 360° rotary coupling for pump handle (separate pump with SPIDER 175 and 400)
- Pressure build-up or reduction by rotation of handle on cut-off valve
- Pressure control valve prevents overload
- Parts under mechanical load are made from high quality chromium-molybdenum steel
- Maximum possible reduction in torsional and frictional forces due to chromium plated piston made from quenched and tempered steel
- Height of stroke adjustable by means of standard adapter
- High load capacity of extraction arms and claws through manufacture as single piece
- Simple centring by spring-loaded steel cone
- "Quick" screw thread for setting of optimum grip depth
- Simple conversion to two-arm operation if insufficient space for three arms



Products · Mounting/Repair

Mechanical mounting and dismantling

Hydraulic extractors

SPIDER 40...80:
Hydraulic standard extractor with integral hand pump

Compact extractor for extraction forces up to 80 kN, together with safety grid in rigid case

SPIDER 40...80

Ordering designation Extractor	Extraction force kN	Grip width mm	Grip depth mm	Stroke mm	Mass kg
PULLER-HYD40	40	150	152	55	4,5
PULLER-HYD60	60	200	152 (190*)	82	4,9
PULLER-HYD80	80	250	190 (229*)	82	6,6

* With optional longer extraction arms, replacement parts can be ordered individually



SPIDER 100...300:
Extra strong hydraulic extractor with integral hand pump

For difficult dismantling work with extraction forces up to 300 kN, with longer extraction arms on request. With accessories in rigid metal case.

SPIDER 100...300

Ordering designation Extractor	Extraction force kN	Grip width mm	Grip depth mm	Stroke mm	Mass kg
PULLER-HYD100	100	280	182 (220*)	82	5,6
PULLER-HYD120	120	305	220 (259*)	82	7,6
PULLER-HYD200	200	356	259 (300*)	82	10
PULLER-HYD250	250	406	300 (375*)	100	20
PULLER-HYD300	300	540 (800*)	375 (405*)	100	25

* With optional longer extraction arms, replacement parts can be ordered individually



SPIDER 175 + 400:
Extra strong hydraulic extractor with separate hand pump

Extractor for restricted spaces, connected to hand pump by hydraulic hose, extraction force up to 400 kN (top of the range model)

SPIDER 175 + 400

Ordering designation Extractor	Extraction force kN	Grip width mm	Grip depth mm	Stroke mm	Mass kg
PULLER-HYD175	175	356	229 (300*)	82	15,6
PULLER-HYD400	400	800 (1200*)	405 (635*)	250	49

* With optional longer extraction arms, replacement parts can be ordered individually



Products · Mounting/Repair Mechanical mounting and dismounting

Three-section extraction plates

Three-section FAG extraction plates PowerPull PULLER-TRISECTION... for hydraulic and mechanical extractors

These allow the extraction of complete bearings, tightly fitted inner rings and other components. The load capacity and extraction force are precisely matched to each other.

The SPIDER extraction claws grip directly under the screw studs of the PULLER-TRISECTION and give uniform distribution of force. Even where parts are firmly seated, there is no tilting or bending. The high extraction forces are concentrated, for example, on the bearing inner ring. In general, the bearing and shaft remain intact and can be used again.

The PULLER-TRISECTION is field-tested and can be fitted under the bearing with just a few movements.

For detailed information, see TPI WL 80-56.

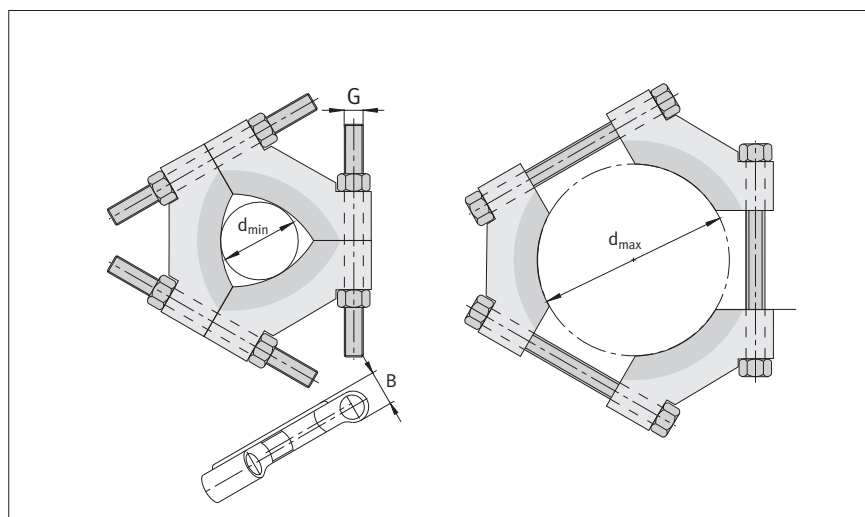

Three-section FAG extraction plates PowerPull PULLER-TRISECTION...

Ordering designation Extraction plate	Dimensions			Mass kg	Recommended for hydraulic extractor SPIDER	mechanical extractor
	d _{min} mm	d _{max}	B			
PULLER-TRISECTION-50	12	50	17	0,5	–	52-085/52-130
PULLER-TRISECTION-100	26	100	28	2,6	40/60/80/100	52-230
PULLER-TRISECTION-160	50	160	33,5	5,8	80/100/120/175/200	52-295
PULLER-TRISECTION-260	90	260	46,5	18,4	175/200/250/300	52-390
PULLER-TRISECTION-380	140	380	65	50,3	250/300/400	52-640

Products · Mounting/Repair

Hydraulic mounting and dismounting

Hydraulic nuts

FAG hydraulic nuts HYDNUT...

Hydraulic nuts HYDNUT... can be used to press parts with a tapered bore onto their tapered seat. Presses are mainly used if the drive-up forces required cannot be applied using other devices, e.g. shaft nuts or pressure screws.

They are mainly used for:

- mounting of rolling bearings with a tapered bore. The bearings can be seated directly on a tapered shaft, on an adapter sleeve or an extraction sleeve. If the bearing is located using an extraction sleeve or an adapter sleeve, the hydraulic nut can also be used for dismounting.
- mounting of couplings, gears, ships' propellers etc.

For detailed information, see TPI WL 80-57.



FAG hydraulic nuts HYDNUT...

Ordering designation	Design	Main application
HYDNUT50 to HYDNUT200 HYDNUT205 to HYDNUT1180	With metric precision thread to DIN 13 With trapezoidal thread to DIN 13	Standardised adapter and extraction sleeves with metric dimensions
HYDNUT90-INCH to HYDNUT530-INCH	With inch size thread to ABMA Standards for Mounting Accessories, Section 8, Locknut Series N-00	Sleeves with inch dimensions
HYDNUT100-HEAVY to HYDNUT900-HEAVY	Reinforced design with smooth bore	For high mounting forces, e.g. in shipbuilding
HYDNUT.GAUGE-DISPLACE	Displacement gauge for HYDNUT (see also page 20)	Where radial internal clearance cannot be measured using feeler gauge due to poor accessibility

Products · Mounting/Repair Hydraulic mounting and dismounting

Displacement gauge for hydraulic nuts

FAG displacement gauge for hydraulic nuts

If the radial internal clearance cannot be measured with a feeler gauge due to poor accessibility, the axial displacement of the bearing can be measured on the tapered seat. This can be achieved by means of a gauge screw mounted to the end face of the hydraulic nut. If the axial threaded connector hole G $\frac{1}{4}$ of the hydraulic nut is taken up by the pump, the second axial hole can be used for the displacement gauge.

The bearing is first placed in its starting position. The oil pressure required is dependent on the bearing size and the number of displacement surfaces and is given in the user manual. A hand pump set with a manometer must be used, see page 25. The dial gauge is set to zero and the bearing is moved by pumping until the specified drive-up distance is achieved.

The user can determine which of the metering needles supplied should be used from the comprehensive user manual included with each gauge.

Ordering designation:

HYDNUT.GAUGE-DISPLACE

1 displacement gauge with dial gauge, 6 metering needles and seals in case



For detailed information, see
TPI WL 80-57.

Products · Mounting/Repair

Hydraulic mounting and dismounting

Mounting Manager

FAG Mounting Manager

The FAG computer program **MOUNTING MANAGER** is a user-friendly aid for ensuring the correct mounting of bearings and offers the following options:

- It shows various mechanical and hydraulic mounting methods
- It calculates the data required for mounting in relation to reduction in radial internal clearance, displacement and start pressure
- It gives useful mounting advice
- It generates a list of the accessories and tools required

Further information on mounting and dismounting of bearings is offered in the integrated library containing appropriate publications, Technical Information documents etc. and our electronic learning system.

Calculation possibilities for mounting methods:

Bearings with a tapered bore are mounted either directly on the tapered shaft or journal or by means of an adapter sleeve or extraction sleeve on the cylindrical shaft. The internal clearance is set either by conventional means using feeler gauges or by means of the axial displacement.

a) Mounting of bearings with tapered bore by measurement of the axial displacement

The bearing is placed in its starting position on the tapered bearing seat with a hydraulic nut. The required starting pressure defined for each individual bearing is set in the hydraulic nut by means of the digital manometer. The dial gauge mounted on the hydraulic nut is used to measure the axial drive-up until the final position is reached on the tapered seat.

This mounting method:

- shortens and simplifies mounting considerably
- offers very high security and accuracy
- allows the correct mounting of sealed bearings

b) Mounting of bearings with tapered bore by measurement of the reduction in radial internal clearance

When the bearing is pushed onto the tapered seat, the inner ring is expanded and the radial internal clearance is thereby reduced. This reduction in radial internal clearance is valid as a measure of the firm seating of the bearing. It is measured by means of a feeler gauge.

The FAG Mounting Manager is available on CD-ROM.



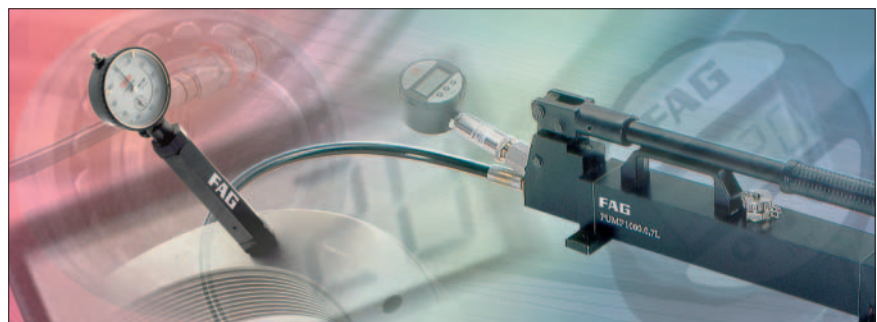

Ordering designation:
CD-MM 1.1



Products · Mounting/Repair

Hydraulic mounting and dismounting

Overview of pressure generation devices

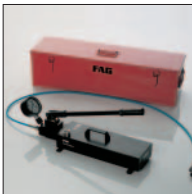
Overview of pressure generation devices					
	Pressure device Oil injector		Hand pump set		
			Single stage	Twin stage	
	INJECT2500	INJECT1600	PUMP1000-0,7L	PUMP1000-4L	PUMP1600-4L
					
Oil container volume [l]	0,008	0,027	0,7	4	4
Connector	G ³ / ₈	G ³ / ₄	G ¹ / ₄	G ¹ / ₄	G ¹ / ₄
Max. oil pressure [bar]	2 500	1 600	1 000	1 000	1 600
(psi)	36 250	23 200	14 500	14 500	23 200
Application	Mounting and dismounting of bearings with tapered bore. Press fits up to approx. 125 N/mm ² contact pressure.	Mounting and dismounting of bearings with tapered bore. Press fits up to approx. 80 N/mm ² contact pressure.	Mounting and dismounting of rolling bearings. Mounting of press fits up to approx. 50 N/mm ² contact pressure. For driving hydraulic nuts up to HYDNUT395/ HYDNUT300-HEAVY	Mounting and dismounting of rolling bearings. Mounting of press fits up to approx. 50 N/mm ² contact pressure, e.g. of ships' propellers. For driving hydraulic nuts up to HYDNUT800	Mounting and dismounting of rolling bearings. Mounting of press fits up to 80 N/mm ² contact pressure, e.g. of rudder spindles and rudder blades
Max. shaft ø [mm]	80	150	250	Unlimited	Unlimited



Products · Mounting/Repair

Hydraulic mounting and dismantling

Overview of pressure generation devices

Overview of pressure generation devices

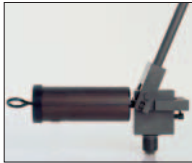
Pressure device

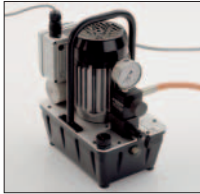
	Hand pump set Twin stage PUMP2500-4L	High pressure pump PUMP4000-0,2L	High pressure pump set PUMP2500-0,2L-KIT	Hydraulic unit Compressed air AGGREG-P1000-1/P2500-2	Electric AGGREG-E700
					
Oil container volume [l]	4	0,2	0,2	13	10
Connector	G ¹ / ₄ (direct)	G ³ / ₄ (direct)	G ¹ / ₄ with high pressure hose	G ¹ / ₄	G ¹ / ₄
Max. oil pressure [bar] (psi)	2 500 36 250	4 000 58 000	2 500 36 250	2 500 36 250	700 10 150
Application	Mounting and dismantling of bearings. Mounting of press fits up to approx. 125 N/mm ² contact pressure, e.g. of gears and couplings.	For press fits with high contact pressure (> 100 N/mm ²). Dismounting of bearings with cylindrical bore. Flow rate and oil reservoir are small.	For press fits with high contact pressure (> 100 N/mm ²). Dismounting of bearings with cylindrical bore. Flow rate and oil reservoir are small.	Mounting of shaft couplings and press fits, gears etc. by the hydraulic method. Contact pressure up to 100 N/mm ² .	For driving large hydraulic nuts up to HYDNUT1180. Mounting of large press fits: ship shaft couplings, ships' propellers, gears, contact pressure up to 50 N/mm ² .
Max. shaft ø [mm]	Unlimited	Unlimited For rolling bearings up to d = 250 mm	Unlimited	Unlimited	Unlimited

Detailed information on FAG pressure generation devices is given in TPI WL 80-50.

Products · Mounting/Repair

Hydraulic mounting and dismounting

Oil injectors

FAG oil injectors

Oil injectors have a small volume displacement; they can be used in the hydraulic method for the dismounting of rolling bearings and other press fits with direct seating on tapered shafts, e.g. in machine tools for cylindrical roller bearings FAG NNU49..-S-K, NN30..-AS-K, N10..-K, N19..-K.

The INJECT2500 can be used for shaft diameters up to 80 mm, the INJECT1600 up to 150 mm.

Conventional O rings can be used as replacement seals:
OR6×1,5 (for INJECT2500),
OR10×2,0 (for INJECT1600).

For detailed information, see TPI WL 80-50.



FAG oil injectors

Oil injector	Valve nipple	Connector	Oil volume	Max. oil pressure	Mass ≈
Ordering designation			cm ³	bar	kg
INJECT2500	INJECT2500.VALVE	G ³ / ₈	8	2 500	0,91
INJECT1600	INJECT1600.VALVE	G ³ / ₄	27	1 600	2,18

The oil injector can be refilled with oil without losses by connecting the valve nipple to the oil injector. In this case, the oil injector is ordered with a valve nipple.

Ordering designation for INJECT2500 + INJECT2500.VALVE: **INJECT2500-SET**

Ordering designation for INJECT1600 + INJECT1600.VALVE: **INJECT1600-SET**

Products · Mounting/Repair

Hydraulic mounting and dismounting

Hand pump sets

FAG hand pump sets

FAG offers one hand pump set with a single stage pump and three hand pump sets with a twin stage pump. The twin stage pumps have a high flow rate in the low pressure range (up to 50 bar) and then switch

automatically to the high pressure stage. This gives a high work rate. Where there is an increased oil requirement, the twin stage pumps are available with an 8 litre oil container (suffix 8L). In cases where the type of installation of the adapter or

extraction sleeve requires a separate oil supply, we can upon request supply a two-way valve (suffix D).

For detailed information, see TPI WL 80-50.



PUMP1000-0,7L-DIGI



PUMP2500-8L-D

FAG hand pump sets (overview of ordering designations)

Pump	Hand pump set Base design	With 8 litre oil container	With distributor	With 8 litre oil container and distributor
Single stage 1 000 bar	PUMP1000-0,7L*			
Twin stage 1 000 bar	PUMP1000-4L*	PUMP1000-8L*	PUMP1000-4L-D	PUMP1000-8L-D
1 600 bar	PUMP1600-4L	PUMP1600-8L	PUMP1600-4L-D	PUMP1600-8L-D
2 500 bar	PUMP2500-4L	PUMP2500-8L	PUMP2500-4L-D	PUMP2500-8L-D

* The 1 000 bar pumps with one connector are also available with a digital manometer.

Ordering example: **PUMP1000-0,7L-DIGI**

Products · Mounting/Repair

Hydraulic mounting and dismounting

High pressure pump · High pressure pump sets

FAG high pressure pump PUMP4000-0,2L

The high pressure pump is suitable for mounting and dismounting of rolling bearings for shaft diameters up to 250 mm. Since it generates pressures of up to 4 000 bar, the pump can be used to expand heavy shaft couplings and gears by the hydraulic method. The pump is connected directly or via thick-walled adapters.

The high pressure pump can also be connected via a pump holder (with or without a manometer) and a 2 m long flexible high pressure hose (maximum permissible oil pressure 2 500 bar). The pump must always be operated with a manometer.

For detailed information, see TPI WL 80-50.

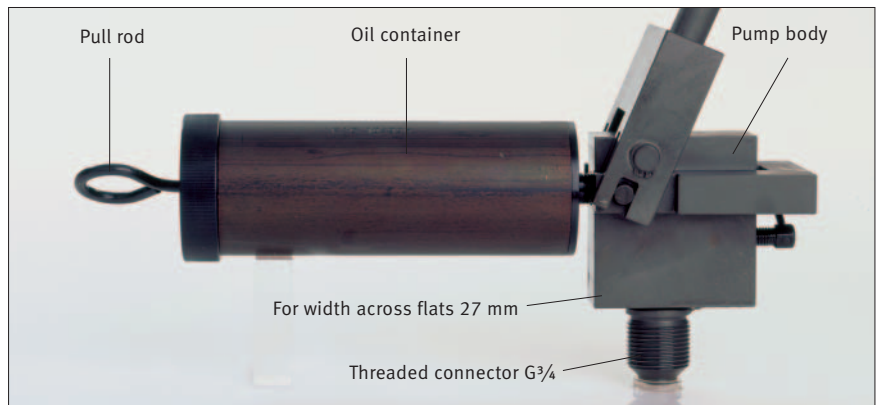

FAG high pressure pump PUMP4000-0,2L

High pressure pump	Connector	Oil container volume	Flow rate	Max. oil pressure	Mass ≈
Ordering designation		l	cm ³ /stroke	bar	kg
PUMP4000-0,2L	G ³ / ₄	0,2	0,3	4 000	3,8
comprising					
PUMP4000-0,2L.BODY (pump body)					
PUMP4000-0,2L.TANK (oil container)					

FAG high pressure pump sets

In order to make it easier to select the right device, we supply complete sets in storage cases:



FAG high pressure pump set PUMP2500-0,2L-KIT

For detailed information, see TPI WL 80-50.

FAG high pressure pump set PUMP2500-0,2L-KIT with manometer up to 2 500 bar

Included in delivery:

- | | |
|------------------------------------|----------------------|
| 1 high pressure pump PUMP4000-0,2L | 1 manometer |
| 1 pump holder | 1 high pressure hose |
| 3 reduction nipples | 1 storage case |

Ordering designation for set: **PUMP2500-0,2L-KIT**

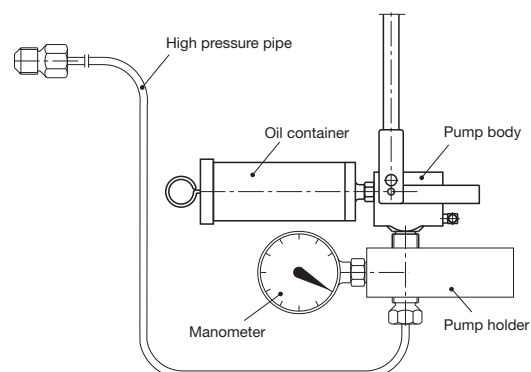

Products · Mounting/Repair

Hydraulic mounting and dismantling

Hydraulic systems and units

Compressed air driven FAG hydraulic unit

The FAG hydraulic unit AGGREG-P1000-1/P2500-2 driven by compressed air is mobile and comprises a 13 litre oil container made from light metal and two pumps (1000 bar and 2 500 bar). We can supply designs for other operating pressures by agreement. The pump (2 500 bar) has two separately controllable outputs and is suitable as a pressure device for expanding shaft couplings and

gears by the hydraulic method. The pump (1000 bar) can drive a hydraulic nut at the same time. The pump is suitable for press fits with contact pressures up to 100 N/mm².

Included in delivery:
Base device, ready-to-use,
incl. 1 manometer 0 to 1000 bar,
1 manometer 0 to 2 500 bar,
3 high pressure hoses 2 500 bar,
2 m

Compressed air driven FAG hydraulic unit

Hydraulic unit	Oil container volume	Max. oil pressure	Mass
Ordering designation	l	bar	≈ kg
AGGREG-P1000-1/P2500-2	13	1000 or 2 500	40 (without oil)

Electrically driven FAG hydraulic unit

These units are suitable for driving large hydraulic nuts and mounting of large press fits such as ship shaft couplings, ships' propellers and gears (contact pressure up to 50 N/mm²).
Electrical connection: plug, voltage 400 V at 50 Hz.
Other voltages and frequencies by agreement.

Included in delivery:
Base unit, ready-to-use,
incl. 1 manometer, 0 to 1000 bar,
1 high pressure hose 1000 bar,
2 m, 1 pressure control valve

Electrically driven FAG hydraulic unit

Hydraulic unit	Oil container volume (suction quantity)	Oil volume flow	Max. oil pressure	Motor rating	Mass
Ordering designation	l	l/min	bar	kW	≈ kg
AGGREG-E700	10	0,9	700	1,1	40 (with oil)

Mobile FAG hydraulic unit for batch mounting

The mobile unit has a valve-controlled, double direction pressure cylinder (pressure force 700 kN, stroke 215 mm) driven by a motor pump. The height position of the cylinder can be varied between 290 and 690 mm by means of a lifting cylinder and rocker. Accessories such as guide bushes, mounting sleeves, traction and pressure spindles and drawing

frames must be ordered according to the individual application. When making enquiries or placing orders, information on the bearing type and power connection as well as installation drawings (shaft, housing, additional parts) are required. This unit is predominantly used for the mounting and dismantling of FAG wheelset bearings TAROL (see also publication TPI WL 80-50).

Ordering designation:
TOOL-RAILWAY-AGGREGATE



Products · Mounting/Repair

Hydraulic mounting and dismounting

Connectors, accessories

FAG adapters and reduction nipples

Adapters and reduction nipples are matched to the threads of high pressure hoses and pressure pipes. Adapters and reduction nipples of type A (with sealing ring) are suitable for oil pressures up to 800 bar.

Type B (with blade sealing) is suitable for oil pressures up to 2 500 bar.

Other adapters and reduction nipples can be supplied by agreement.

For detailed information, see TPI WL 80-50.

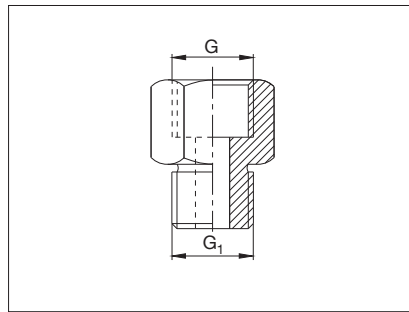

Type A (with sealing ring)

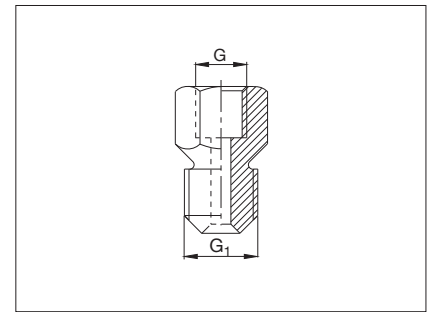

Type B (with blade sealing)



Reduction nipple

Reduction nipple $G > G_1/G < G_1$
Ordering designation

PUMP.NIPPLE-A-G³/₄-G¹/₈
 PUMP.NIPPLE-B-G³/₄-G¹/₈

PUMP.NIPPLE-A-G¹/₄-G¹/₂
 PUMP.NIPPLE-B-G¹/₄-G¹/₂

PUMP.NIPPLE-A-G³/₄-G³/₄
 PUMP.NIPPLE-B-G³/₄-G³/₄

PUMP.NIPPLE-A-G¹/₄-M14
 PUMP.NIPPLE-B-G¹/₄-M14

PUMP.NIPPLE-A-G¹/₄-M18×1,5

PUMP.NIPPLE-A-G³/₈-G¹/₄
 PUMP.NIPPLE-B-G³/₈-G¹/₄

PUMP.NIPPLE-A-G³/₈-G¹/₈
 PUMP.NIPPLE-B-G³/₈-G¹/₈

PUMP.NIPPLE-A-G³/₈-G¹/₄
 PUMP.NIPPLE-B-G³/₈-G¹/₄

Reduction nipple

Reduction nipple $G > G_1/G < G_1$
Ordering designation

PUMP.NIPPLE-A-G³/₄-G³/₈
 PUMP.NIPPLE-B-G³/₄-G³/₈

PUMP.NIPPLE-A-M18×1,5-G¹/₄

PUMP.NIPPLE-A-M18×1,5-G³/₈

PUMP.NIPPLE-A-M18×1,5-G³/₄

Adapter

Adapter $G_1 = G$
Ordering designation

PUMP.ADAPTER-A-G¹/₄

PUMP.ADAPTER-B-G¹/₄

PUMP.ADAPTER-A-G³/₄

PUMP.ADAPTER-B-G³/₄

Products · Mounting/Repair

Hydraulic mounting and dismounting

Connectors, accessories

FAG pump holders

FAG pump holders

Pump holder	Ordering designation	Mass ≈ kg
Without connector for manometer	PUMP.HOLDER-2	1,95
With connector G $\frac{1}{2}$ for manometer	PUMP.HOLDER.3	1,95



FAG manometers

When selecting a manometer, pay attention to the max. operating pressure.



FAG manometers

Manometer	Threaded connector	Pressure display	Diameter	Mass
Ordering designation		bar	mm	kg
PUMP1000.MANO-DIGI	G $\frac{1}{4}$	0–1 000	73	0,4
PUMP1000.MANO-G$\frac{1}{2}$	G $\frac{1}{2}$	0–1 000	100	0,8
PUMP1600.MANO-G$\frac{1}{2}$	G $\frac{1}{2}$	0–1 600	100	1,5
PUMP2500.MANO-G$\frac{1}{2}$	G $\frac{1}{2}$	0–2 500	160	1,7

For detailed information, see TPI WL 80-50.

Products · Mounting/Repair

Hydraulic mounting and dismounting

Connectors, accessories

FAG high pressure pipes for high pressure pumps, sheathed in PVC hose (max. permissible pressure of 2 500 bar should be monitored by manometer)

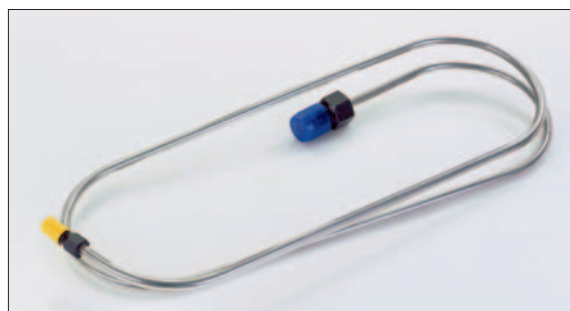

FAG high pressure pipe

High pressure pipe	Connector	Mass ≈ kg
Ordering designation		
PUMP.PIPE-G $\frac{1}{4}$	G $\frac{1}{4}$	0,6
PUMP.PIPE-G $\frac{3}{8}$	G $\frac{3}{8}$	0,6
PUMP.PIPE-G $\frac{1}{2}$	G $\frac{1}{2}$	0,6
PUMP.PIPE-G $\frac{3}{4}$	G $\frac{3}{4}$	0,8

The connector for the pump holder is G $\frac{3}{4}$.

For other connectors, a suitable reduction nipple must be used in addition.

For detailed information, see TPI WL 80-50.

FAG sleeve connectors for adapter and extraction sleeves (up to 800 bar)

(special lengths available by agreement)



FAG sleeve connectors

Connector	Threaded connector	Mass ≈ kg
Ordering designation		
PUMP.SLEEVE-CONNECTOR-M6	M6	0,22
PUMP.SLEEVE-CONNECTOR-M8	M8	0,245
PUMP.SLEEVE-CONNECTOR-G $\frac{1}{8}$	G $\frac{1}{8}$	0,285
PUMP.SLEEVE-CONNECTOR-G $\frac{1}{4}$	G $\frac{1}{4}$	0,42

The connector for the hand pump set is G $\frac{1}{4}$.

For detailed information, see TPI WL 80-50.

Products · Mounting/Repair

Thermal mounting and dismounting

Electric heating plates · Induction heating devices

FAG electric heating plate HEATER-PLATE

The temperature-controlled FAG heating plate HEATER-PLATE can be used to heat rolling bearings (up to a maximum of 120 °C) or small machine components up to 5 kg mass.

The removable housing cover protects the workpieces from contaminants and ensures uniform and rapid heating.

This inexpensive device is maintenance-free and easy to handle.

Dimensions (W×D×H):
390×270×156 mm
Plate size 380×180 mm
Power: max. 1 500 W
at 230 V/50 Hz
Temperature control:
continuously variable
from +50 to +200 °C
Mass: 5,6 kg

Ordering designation:
HEATER-PLATE

Ordering designation for version
with 115 V/60 Hz:
HEATER-PLATE-115V



FAG heating plate HEATER-PLATE

FAG electric heating plate HEATER-PLATE-370C

The HEATER-PLATE-370C is used principally for heating the FAG aluminium heating rings HEATING-RING (see page 34). It can also be used for the heating of rolling bearings.

Heating rings are suitable for dismounting the inner rings of cylindrical roller and needle roller bearings without ribs and inner rings with one rib. The heating rings are heated to a temperature of 200–300 °C. The outside diameter of the workpieces can be up to max. 350 mm, the mass can be up to 20 kg.

Dimensions (W×D×H):
360×360×170 mm
Plate size 350×350 mm
Power: max. 2 200 W at 230 V/50 Hz
Power control: 0 to 100 %
Temperature control:
continuously variable
from +100 to +370 °C
Mass: approx. 13 kg

Ordering designation:
HEATER-PLATE-370C
Ordering designation
for 115 V/60 Hz version:
upon request



FAG heating plate HEATER-PLATE-370C

FAG induction heating devices

Many rolling bearings and other rotationally symmetrical parts made from steel have tight fits on the shaft. In particular, larger parts can be mounted more easily if they are heated first.

Rapid and clean induction heating is superior to the conventional methods. It is therefore particularly suitable for batch mounting. Heating is carried out on complete bearings, rings for cylindrical roller or needle roller bearings and rotationally symmetrical steel parts such as labyrinth rings, roll couplings, tyres etc.

Advantages

- Rapid, energy-efficient operation
- Suitable for rolling bearings and other ring-shaped steel parts
- Very safe operation
- Environmentally friendly, oil-free (no disposal required)
- Uniform, controlled heating
- Easy to use
- Automatic demagnetisation
- High cost-effectiveness through selection of the most suitable size of device for the particular application
- Suitable for batch mounting

For the mounting of workpieces up to 300 kg mass, FAG supplies five table-top heating devices PowerTherm HEATER10 to 300 suitable for mobile and/or stationary use.

For workpieces up to 3 000 kg mass, we recommend the particularly heavy duty standalone devices HEATER600, HEATER1200 and HEATER3000.

For detailed information, see TPI WL 80-54.

Products · Mounting/Repair

Thermal mounting and dismounting

Induction heating devices

Overview of induction heating devices

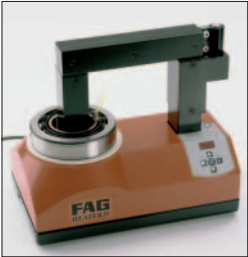
Heating device	HEATER10	HEATER20	HEATER35	HEATER150
				
Power consumption max.¹⁾	2,3 kVA	3,6 kVA	3,6 kVA	12,8 kVA
Voltage/frequency²⁾	230 V/50 Hz	230 V/50 Hz	230 V/50 Hz	400 V/50 Hz
Current	10 A	16 A	16 A	32 A
Mass	7 kg	17 kg	31 kg	51 kg
Length	230 mm	345 mm	420 mm	505 mm
Width	200 mm	200 mm	260 mm	260 mm
Height	240 mm	240 mm	365 mm	440 mm
Dimension a	65 mm	120 mm	180 mm	210 mm
Dimension b	95 mm	100 mm	160 mm	210 mm
Ledges (incl.) for workpieces of min. bore	20/45/65 mm (graduated supports)	20 mm 35 mm 60 mm	70 mm	100 mm
Ledges (accessories) for workpieces of min. bore	10 mm 15 mm 35 mm	10 mm 15 mm 45 mm	15 mm 20 mm 45 mm 60 mm	20 mm 30 mm 60 mm 70 mm 85 mm

¹⁾ If lower voltage is used, the power will be reduced.

²⁾ Upon request, we can also supply heating devices with other rated voltages and frequencies as well as higher power ratings.

Overview of induction heating devices

Heating device HEATER300³⁾ HEATER600 HEATER1200 HEATER3000

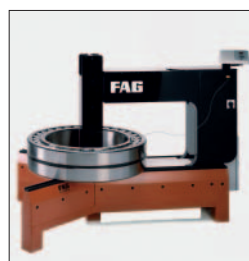
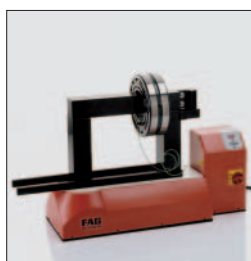
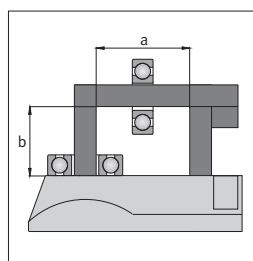

Power consumption max.¹⁾

Voltage/frequency²⁾

Current

12,8 kVA

400 V/50 Hz

32 A

25 kVA

400 V/50 Hz

63 A

40 kVA

400 V/50 Hz

100 A

100 kVA

400 V/50 Hz

250 A

Mass

Length

Width

Height

75 kg (+25 kg)³⁾

870 mm

300 mm

580 mm

(900 mm)³⁾

350 kg

1 100 mm

850 mm

1 250 mm

850 kg

1 500 mm

1 100 mm

1 400 mm

1 800 kg

2 500 mm

1 500 mm

1 800 mm

Dimension a

Dimension b

330 mm

260 mm

430 mm

400 mm

700 mm

450 mm

700 mm

800 mm

Ledges (incl.) for workpieces of min. bore

115 mm

145 mm

215 mm

285 mm

Ledges (accessories) for workpieces of min. bore

30 mm

45 mm

60 mm

70 mm

85 mm

100 mm

45 mm

60 mm

70 mm

85 mm

100 mm

115 mm

130 mm

85 mm

115 mm

145 mm

145 mm

215 mm

³⁾ Convertible to a mobile version by adding HEATER300.TROLLEY

Products · Mounting/Repair

Thermal mounting and dismantling

Heating rings · Heat conducting paste

FAG heating rings

Heating rings are suitable for dismantling the inner rings of cylindrical roller and needle roller bearings without ribs and inner rings with one rib. Heating rings are particularly advantageous for the occasional extraction of small and medium-sized bearing rings (bore diameter 50 to 200 mm). Depending on the size of the ring, heating takes between 5 and 30 seconds.

The heating rings are made from light metal. They have a radial slot. They are easy to handle due to the heat-insulated handles.

Heating rings are heated to between 200 and 300 °C by means of an electric heating plate. The cylindrical outside surface of the bearing inner ring must be coated with a silicone-free heat conducting paste (HEATING-RING.PASTE). This gives optimum heat transfer. The heating ring is then slid over the inner ring to be extracted.

The bearing ring must be removed from the heating ring immediately after extraction in order to prevent overheating.

Each bearing size requires a specific heating ring. By agreement, we can supply these heating rings made from a special aluminium alloy.

In order to prepare a quotation, we require the following information:

1. Bearing designation or ring dimensions,
2. Drawing of mounting position stating fits.
3. Approximate number of parts to be extracted per day

Recommended FAG accessories

- Electric heating plate for temperatures up to 370 °C
HEATER-PLATE-370C
- Temperature gauge
TEMP-CHECK-CONTACT
(see page 62)
- Gloves **GLOVE2**
- Heat conducting paste (see below)
HEATING.RING.PASTE-20ML
(20 ml included in delivery)

Ordering examples for heating rings

HEATING-RING-320E

(for inner ring of cylindrical roller bearing NU320-E, NJ320-E etc.)

HEATING-RING-2317E

(for inner ring of cylindrical roller bearing NU2317-E, NJ2317-E etc.)

For detailed information, see TPI WL 80-58

Expected to be available from April 2008



FAG heat conducting paste HEATING-RING.PASTE

The silicone-free heat conducting paste HEATING.RING.PASTE is used as an aid in the dismantling of bearing inner rings by means of heating rings.

The cylindrical outside surface of the bearing inner ring is coated with the heat conducting paste before extraction in order to achieve optimum heat transfer from the heating ring to the bearing inner ring.

Ordering designation (expandable syringe containing 20 ml silicone-free heat conducting paste):

HEATING-RING.PASTE-20ML

For detailed information, see TPI WL 80-58

Expected to be available from April 2008



Products · Mounting/Repair

Thermal mounting and dismounting

Electric induction heating devices

Electric induction heating devices

Electric induction heating devices are suitable for the dismounting of inner rings on medium-sized and large cylindrical roller and needle roller bearings (bore diameter 90 mm and larger).

They can also be used to heat labyrinth rings, couplings, ring rolls and other rotationally symmetrical parts.

Heating devices with low voltage

This design comprises an induction coil and a transformer.

The coil runs on harmless low voltage and is water-cooled. This allows continuous heating, which is particularly suitable for batch mounting. Due to the lightweight construction, these devices are easy to handle.

Each bearing size requires a specific coil.

The coil is connected to a mobile transformer that can be designed for any mains voltage. The voltage for the coil is adjustable between 20 and 40 V.

The transformers for the induction coils are available from FAG in six different power steps.

The largest transformer and the corresponding coil can be used to heat inner rings up to a maximum mass of 1 200 kg to the required dismounting temperature of 80...120 °C (maximum mass of 600 kg for couplings).

Ordering example for bearing inner rings 120×150×144 mm:

COIL152X145-LOW (coil)

COIL.TRAFO-45KVA-400V-50HZ (transformer)



Heating device for low voltage with transformer for dismounting of the inner rings of cylindrical roller bearings

Heating devices with mains voltage

In addition to coils for low voltage, FAG also supplies coils for mains voltage (with a switch box or foot switch). This economical alternative without water cooling is used for sporadic dismounting (where batch dismounting is not required).



Heating device for low voltage with mains voltage for dismounting of the inner rings of cylindrical roller bearings

Information required for quotation

FAG induction heating devices are always produced as one-off items. In order to prepare a quotation, we require the following information:

1. Exact **designation** of the bearing or **dimensions** of the parts to be extracted
2. Width of the **intermediate ring**, if present
3. The **mains voltage and frequency** present at the mounting location

For detailed information, see TPI WL 80-58

Expected to be available from April 2008

Products · Mounting/Repair Measurement and inspection

Feeler gauges · Taper gauges

FAG feeler gauges FEELER-GAUGE-100 and FEELER-GAUGE-300

Feeler gauges are used to measure the radial internal clearance, especially for mounting on tapered

shaft seats and on adapter and extraction sleeves.

FAG feeler gauges FEELER-GAUGE-100 and FEELER-GAUGE-300

Ordering designation	Feeler length mm	Feeler thickness mm		
FEELER-GAUGE-100	100	0,03	0,08	0,14
		0,04	0,09	0,16
		0,05	0,10	0,18
		0,06	0,12	0,20
		0,07		
FEELER-GAUGE-300	300	0,03	0,12	0,20
		0,04	0,13	0,25
		0,05	0,14	0,30
		0,06	0,15	0,35
		0,07	0,16	0,40
		0,08	0,17	0,45
		0,09	0,18	0,50
		0,10	0,19	



FAG feeler gauges FEELER-GAUGE-100 and FEELER-GAUGE-300

Taper gauges

When a bearing with a tapered bore is seated directly on the shaft, the tapered bearing seat must be

precisely machined so that the fit surfaces match precisely. We supply various gauges for measuring the taper. Most bearings with a tapered bore have a

taper 1:12. Only spherical roller bearings of series 240 and 241 have a taper 1:30.

FAG taper ring gauge

The simplest means of measuring tapered shaft seats on small bearings is the taper ring gauge. By application of inking material, it can be determined whether the shaft and ring gauge match; corrections are made until the ring gauge is in contact over its whole width. The inner rings of the bearings are not suitable as ring gauges because their walls are too thin and could be damaged. We supply taper ring gauges for taper diameters from 30 to 240 mm.

Ordering designation (example):

KLR20

Taper ring gauge for bearings of 100 mm bore, e.g. for double row cylindrical roller bearings NN3020-AS-K or NNU4920-S-K.

FAG taper ring gauge

Taper ring gauge	Taper diameter mm
Ordering designation	mm
KLR06...KLR48	30...240



Products · Mounting/Repair Measurement and inspection

Taper gauges

FAG taper gauge MGK 9205

for the inspection of large tapered shaft studs (taper 1:12 or 1:30)

Measurement principle of taper gauge MGK 9205: When measuring tapered studs of large diameter, a master can be used in which the upper and lower edge form an angle, the taper angle of the stud = 2α . If the upper edge of the master is parallel with the line diametrically opposed to the master, the taper angle is acceptable.

A further requirement is that the taper is in a defined ratio to a reference surface, e.g. to the side face of a roll barrel.

FAG taper gauges MGK 9205 are available in several sizes. The delivery of individual gauges, and also of complete sets, always includes two magnets. Delivery also includes belts for fixing the gauge in positions other than on the upper side of the stud.

Ordering examples for gauge sets (each with two saddles and five masters):

MGK9205-12.SET (taper 1:12)

MGK9205-30.SET (taper 1:30)

See also TI WL 80-70.

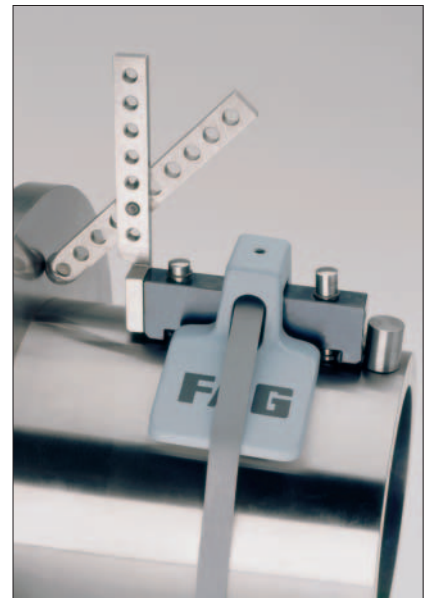

FAG taper gauge MGK 9205

FAG taper gauge MGK 133

for external tapers 1:12 and 1:30 and 27 to 205 mm taper diameter.

The taper gauge MGK 133 rests on the taper with four hardened and polished support pins. The position of the gauge on the taper is defined by these pins and one stop. The stop can be attached to either the front or back of the gauge. The gauge contains two movable measuring brackets, one of which is in contact with the

smaller taper diameter while the other, at a fixed distance, is in contact with the larger taper diameter.

The deviation of the taper diameter from the nominal value is displayed in both measurement planes by a precision indicator.

The reproducibility of the measurement results is less than $1\ \mu\text{m}$. The gauge is set using a gauge taper (available by agreement).



FAG taper gauge MGK 133

Products · Mounting/Repair Measurement and inspection

Taper gauges · Snap gauge

FAG taper gauge MGK 132
for external tapers with 0° to 6°
taper angle and 90 to 510 mm
taper diameter.

With the taper gauge MGK 132, the reproducibility of the measurement results is within 1 µm. The MGK132 rests on the workpiece with four hardened, ground and lapped ledges. The ledges form an angle of 90°. A stop on the front or rear precisely defines the position of the gauge. Between the support ledges, the measurement slide runs on

preloaded roller bearings. A dial gauge fixed in the housing acts against the measurement slide and indicates the deviation of the taper diameter from the nominal value. A precision indicator is fixed to the measurement slide. Its blade-shaped tip is in contact with the workpiece and measures the deviation of the taper from the nominal value. The gauge is set using a gauge taper (available by agreement).



FAG taper gauge MGK 132

FAG snap gauge SNAP-GAUGE-.../...
for inspecting the diameter of
cylindrical shafts and workpieces
of all types, directly on the
machine tool and for setting the
enveloping circle gauge MGA 21
(see page 39).

The actual dimension of the workpiece can be determined precisely. The snap gauge functions as a comparator gauge. Its setting is checked using shims. We supply the shims required for each diameter.

Available snap gauges

Ordering designation	Measurement range mm
SNAP-GAUGE-30/60	30–60
SNAP-GAUGE-60/100	60–100
SNAP-GAUGE-100/150	100–150
SNAP-GAUGE-150/200	150–200
SNAP-GAUGE-200/250	200–250
SNAP-GAUGE-250/300	250–300

Ordering example
for shaft diameter 120 mm:
SNAP-GAUGE-100/150
(snap gauge)
SNAP-GAUGE.MASTER120
(shim)



FAG snap gauge

Products · Mounting/Repair Measurement and inspection

Enveloping circle gauges

FAG enveloping circle gauge MGA 21 for setting the radial internal clearance of cylindrical roller bearings NNU4920-K to NNU4964-K and NNU4920 to NNU4964.

Bearings of bore diameter 100 to 320 mm have removable inner rings.

In the FAG enveloping circle gauge MGI 21, the internal enveloping circle of the roller and cage assembly is measured by two hardened and precision ground surfaces, one of which is movable. After mounting of the outer ring, the gauge is set to the internal enveloping circle of the roller and

cage assembly. This dimension is measured using a snap gauge, for example the SNAP-GAUGE.../... (see page 38).

It is then possible to set the inner ring to the diameter that gives the required radial internal clearance. Bearings with a tapered bore are slid onto the tapered seat of the shaft.

For bearings with a cylindrical bore, preground inner rings are used (suffix F12) and finish ground to the required raceway diameter.

Ordering example for NNU4920:
MGI21-4920



FAG enveloping circle gauge MGI 21 for setting the radial internal clearance or preload of cylindrical roller bearings with removable inner ring

FAG enveloping circle gauge MGA 31 for setting the radial internal clearance of cylindrical roller bearings NN3006-K to NN3038-K and N1006-K to N1048-K.

Bearings with a tapered bore have removable outer rings.

The gauge is used to precisely set the radial internal clearance or preload of cylindrical roller bearings.

The raceway diameter of the mounted outer ring is measured using a conventional internal gauge. This dimension is transferred

to the two hardened and precision ground measuring surfaces of the enveloping circle gauge.

The tapered shaft with the premounted inner ring and roller and cage assembly can then be inserted in the gauge. The shaft is moved axially by the hydraulic method until the precision indicator of the enveloping circle gauge shows the required radial internal clearance or preload.

Ordering example for NN3006-K:
MGA31-3006



FAG enveloping circle gauge MGA 31 for setting the radial internal clearance of cylindrical roller bearings with removable outer ring

Products · Mounting/Repair Accessories

Transport and mounting tool

FAG transport and mounting tool

BEARING.MATE is an accessory for the secure, rapid and easy handling of medium-sized and large rolling bearings. It can also be used where bearings are heated prior to mounting.

The tool comprises two handles and two steel strips. Turning the handles clamps the steel strips firmly on the outer ring of the rolling bearing. The compact packaging also includes two brackets. These are used on spherical roller bearings and self-aligning ball bearings in order to prevent tilting of the inner rings. The tool and bearing is carried either by two people or a crane. If two carrying slings are used, the rolling bearing can be rotated to any position when transported by crane. During heating on an induction heating device, the tool remains mounted on the bearing. The steel strips expand uniformly with the bearing. Optimum tension is thus maintained. The three sizes of tool are matched to different bearing outside diameters, see table below.



Accessories

Long brackets to prevent tilting of self-aligning bearing inner rings (2 pieces)

Ordering designation:

BEARING-MATE.LOCKBAR270

Carrying sling, 1 m long (2 pieces)

BEARING-MATE.SLING-1M

Replacement parts

Short brackets to prevent tilting of self-aligning bearing inner rings (2 pieces)

Ordering designation:

BEARING-MATE.LOCKBAR170

Pack of spare parts

BEARING-MATE.SERVICE-KIT

FAG transport and mounting tool

Ordering designation Transport and mounting tool	Bearing outside diameter		Bearing mass max. kg	Operating temperature max. °C	Tool mass kg
	min. mm	max.			
BEARING-MATE250-450	250	450	500	160	6,3
BEARING-MATE450-650	450	650	500	160	6,4
BEARING-MATE650-850	650	850	500	160	6,5

Products · Mounting/Repair Accessories

Gloves

Heat-resistant FAG gloves GLOVE1

Heat-resistant FAG gloves are particularly suitable for the handling of heated rolling bearings or other parts in mounting or dismounting. The outside comprises rugged polyester and can withstand temperatures up to 150 °C. The inside is made from comfortable cotton.

The principal characteristics are:

- resistant up to 150 °C
- lint-free
- asbestos-free
- comfortable
- cut-resistant

Ordering designation:
GLOVE1



Heat-resistant and oil-resistant FAG gloves GLOVE2

Heat-resistant and oil-resistant FAG gloves are particularly suitable for the handling of heated and lubricated rolling bearings in mounting or dismounting.

Their principal characteristics derive from the multiple layer construction comprising different fibres.

The principal characteristics are:

- resistant up to 250 °C
- non-flammable
- heat-resistant even when damp
- authorised for protection against mechanical (DIN EN 388) and thermal (DIN EN 407) influences
- cotton-free
- cut-resistant

Ordering designation:
GLOVE2



Products · Mounting/Repair Accessories

Mounting paste · Anti-corrosion oil

FAG mounting paste

This mounting and multi-purpose paste has proven valuable particularly for the mounting of rolling bearings. It facilitates the sliding of bearing rings and prevents stick-slip, scoring, wear and fretting corrosion. It also gives good protection against corrosion. It is pale in colour and does not cause contamination.

The mounting paste is applied in a very thin layer so that the metallic sheen turns matt.

The permissible operating temperature range is between -30 °C and 150 °C.

The paste is resistant to water, water vapour and many alkaline and acidic media.

Available in:
70 g tubes
250 g tubes
400 g cartridges
1 kg cans

Ordering designation:

ARCANOL-MOUNTINGPASTE-70G
ARCANOL-MOUNTINGPASTE-250G
ARCANOL-MOUNTINGPASTE-400G
ARCANOL-MOUNTINGPASTE-1KG



FAG anti-corrosion oil

The anti-corrosion oil is suitable particularly for unpacked rolling bearings. It can also be sprayed on bright metal surfaces of devices, machines and machine elements to give long term anti-corrosion protection when stored indoors. It is not generally necessary to wash anti-corrosion oil out of rolling bearings since it gives neutral behaviour towards all conventional rolling bearing greases and oils.

It can be easily and effectively removed using alkaline solvents and neutral cleaning agents.

Available in:
0,4 litre spray can with ozone-safe propellant CO₂

Ordering designation:

ARCANOL-ANTICORROSIONOIL-400G



Products · Lubrication



Lubricants 44

Arcanol rolling bearing greases 44

Lubrication systems 48

Motion Guard SELECT MANAGER 48

Motion Guard COMPACT 49

Motion Guard CHAMPION 51

Motion Guard CONCEPT6 52

Metering devices 53

Grease gun 53

Products · Lubrication Lubricants

Arcanol rolling bearing greases

Special rolling bearing greases like Arcanol at first glance cost a little more than standard greases. But they are worth the price. For with Arcanol you can buy some extra security, since Schaeffler KG carries out selection tests, provides quality assurance and gives practice-based lubrication recommendations. Bearings that fail prematurely due to incorrect grease selection, together with all the unpleasant and expensive consequences, are increasingly a thing of the past.

In co-operation with renowned lubricant manufacturers, we have for many years developed lubricating greases that are particularly suitable for rolling bearings. However, before a new grease is included in the Arcanol range, it must pass a series of stringent tests in the Schaeffler lubricant laboratory.

The greases are tested thoroughly. On our lubricant test rigs FE8 (DIN 51819) and FE9 (DIN 51821), the greases are tested in rolling bearings to find out how they improve service life and reduce friction and wear. Only the best greases are then selected to undergo the subsequent tests under simulated field conditions in far more complicated rolling bearing test rigs. If the results meet the requirements of the stringent FAG specifications, the greases are included in the Arcanol range. They thus receive the Arcanol seal of quality.

In addition, we test every single batch to ensure the uniform quality of the product. It is only after the grease has passed this final test that it is allowed to be filled into containers labelled Arcanol. The range is structured such that these greases cover nearly all fields of application in an optimum manner.

The overview on pages 46/47 shows chemical-physical data, fields of application and the conditions for which these greases are suitable. The selection of a suitable grease is considerably facilitated by the electronic INA/FAG rolling bearing catalogue.

- **More than 80% of all rolling bearings are lubricated with grease**
- **Incorrect lubrication causes more than 40% of all cases of rolling bearing damage**
- **Users therefore need lubricants and lubrication recommendations that they can rely on**
- **Arcanol rolling bearing greases ensure that a bearing can be used to its full capacity**
 - long service life
 - good running behaviour
 - high operational reliability

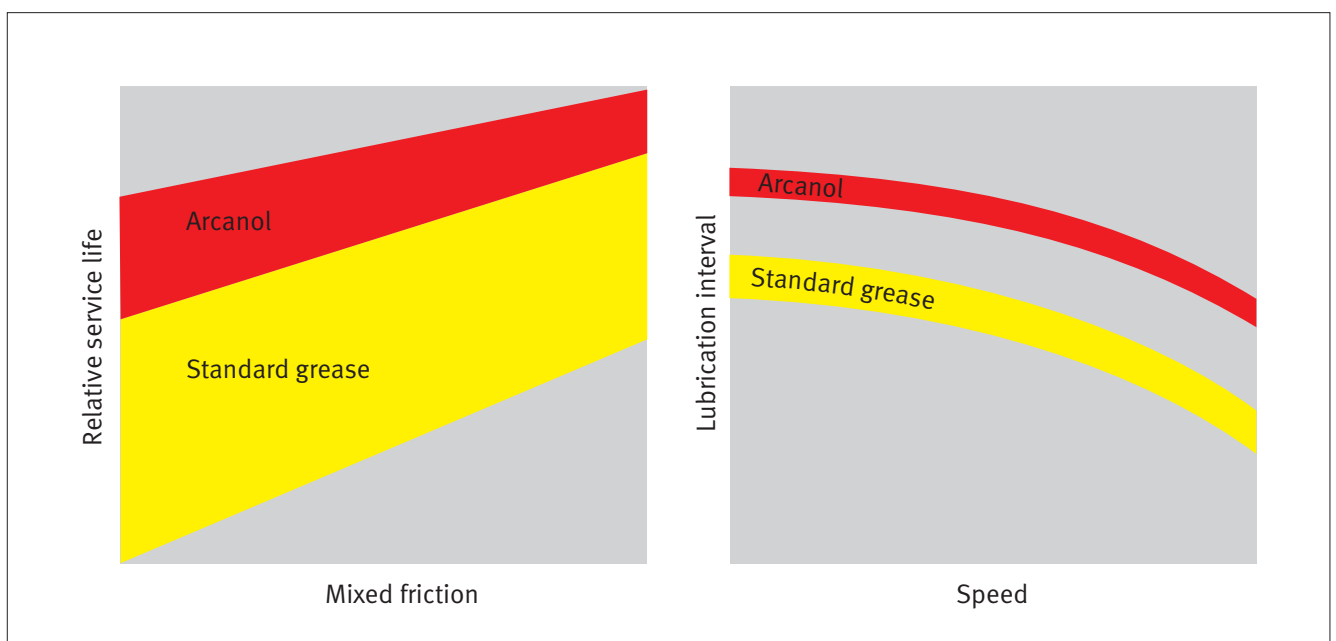

Products · Lubrication

Lubricants

Arcanol rolling bearing greases · Container sizes · Ordering examples

Arcanol rolling bearing greases · Container sizes

Arcanol grease	20 g tube	70 g tube	250 g tube	400 g cartridge	1 kg can	5 kg bucket	10 kg bucket	25 kg hobbock	50 kg hobbock	180 kg drum
MULTITOP	–	–	•	•	•	•	•	•	–	•
MULTI2	•	–	•	•	•	•	•	•	–	•
MULTI3	–	–	•	•	•	•	•	•	–	•
LOAD150	–	–	–	•	•	–	•	–	–	–
LOAD220	–	–	–	–	•	–	•	•	–	•
LOAD400	–	–	–	•	•	•	•	•	•	•
LOAD1000	–	–	–	–	–	•	–	•	–	•
TEMP90	•	–	–	•	•	•	–	•	–	•
TEMP110	–	–	–	•	•	–	–	–	•	–
TEMP120	–	–	–	–	•	•	–	•	–	–
TEMP200	–	•	–	–	•	–	–	–	–	–
SPEED2,6	–	–	•	–	•	–	–	•	–	–
VIB3	–	–	–	•	•	•	–	•	•	–
BIO2	–	–	–	•	•	–	•	•	–	•
FOOD2	–	–	–	•	•	–	•	•	–	•

Other container sizes available by agreement.

Arcanol rolling bearing greases · Ordering examples

Ordering example	Description
ARCANOL-MULTITOP-5KG	FAG rolling bearing grease Arcanol MULTITOP in 5 kg bucket
ARCANOL-MULTI2-20G	FAG rolling bearing grease Arcanol MULTI2 in 20 g tube (50 pieces)
ARCANOL-MULTI3-25KG	FAG rolling bearing grease Arcanol MULTI3 in 25 kg hobbock
ARCANOL-LOAD150-10KG	FAG rolling bearing grease Arcanol LOAD150 in 10 kg bucket
ARCANOL-LOAD220-180KG	FAG rolling bearing grease Arcanol LOAD220 in 180 kg drum
ARCANOL-LOAD400-400G	FAG rolling bearing grease Arcanol LOAD400 in 400 g cartridge (10 pieces)
ARCANOL-LOAD1000-5KG	FAG rolling bearing grease Arcanol LOAD1000 in 5 kg bucket
ARCANOL-TEMP90-1KG	FAG rolling bearing grease Arcanol TEMP90 in 1 kg can
ARCANOL-TEMP110-400G	FAG rolling bearing grease Arcanol TEMP110 in 400 g cartridge
ARCANOL-TEMP120-25KG	FAG rolling bearing grease Arcanol TEMP120 in 25 kg hobbock
ARCANOL-TEMP200-70G	FAG rolling bearing grease Arcanol TEMP200 in 70 g tube
ARCANOL-SPEED2,6-250G	FAG rolling bearing grease Arcanol SPEED2,6 in 250 g tube (10 pieces)
ARCANOL-VIB3-25KG	FAG rolling bearing grease Arcanol VIB3 in 25 kg hobbock
ARCANOL-BIO2-1KG	FAG rolling bearing grease Arcanol BIO2 in 1 kg can
ARCANOL-FOOD2-10KG	FAG rolling bearing grease Arcanol FOOD2 in 10 kg bucket

Products · Lubrication Lubricants

Arcanol rolling bearing greases · Selection table

Overview of Arcanol rolling bearing greases							
	Arcanol MULTITOP	MULTI2	MULTI3	LOAD150	LOAD220	LOAD400	LOAD1000
DIN 51825	KP2N-40	K2N-30	K3N-30	KP2N-20	KP2N-20	KP2N-20	KP2N-20
Thickener	Lithium soap with EP additives	Lithium soap	Lithium soap	Lithium complex soap with EP additives	Lithium/calcium soap with EP additives	Lithium/calcium soap with EP additives	Lithium/calcium soap with EP additives
Base oil	Mineral oil+ester	Mineral oil	Mineral oil	Mineral oil	Mineral oil	Mineral oil	Mineral oil
Base oil viscosity at 40 °C [mm²/s]	85	ISO VG 100	80	ISO VG 150	ISO VG 220	400	ISO VG 1000
Consistency (NLGI class)	2	2	3	2	2	2	2
Operating temperature [°C]	-40...+150	-30...+140	-30...+140	-20...+140	-20...+140	-25...+140	-20...+140
Long term limit temperature [°C]	80	75	75	95	80	80	80
Characteristic areas of application for Arcanol rolling bearing greases	Universal grease for ball and roller bearings	Universal grease for ball bearings D ≤ 62 mm	Universal grease for ball bearings D > 62 mm	Special grease for ball, roller and needle roller bearings, linear guidance systems	Special grease for ball and roller bearings	Special grease for ball and roller bearings	Special grease for ball and roller bearings
	in rolling mills, construction machinery, automotive engineering, spinning and grinding spindles	in small electric motors, agricultural and construction machinery, household appliances	in large electric motors, agricultural and construction machinery, fans	in machine tools	in rolling mill plant, rail vehicles	in mining machinery, construction machinery, wind turbines	in mining machinery, construction machinery, preferably under shock loads and large bearings
	at increased speeds, high loads, low and high temperatures			at high loads, with wide speed range, swivel movements	at high loads, with wide speed range, high humidity	at very high loads, moderate temperatures, moderate speeds	at very high loads, moderate temperatures, low speeds
Low temperatures	++	+	+	o	o	-	o
High temperatures	o	o	o	o	o	o	o
Low friction, high speeds	+	o	o	-	-	-	--
High loads, low speeds	+	o	o	++	++	++	++
Vibrations	+	o	+	+	+	+	+
Support for seals	o	o	+	+	+	+	+
Relubrication facility	++	++	+	+	+	+	+
ISO VG =	++ highly suitable		o suitable			- less suitable	
ISO viscosity group	+ very suitable					-- not suitable	



TEMP90	TEMP110	TEMP120	TEMP200	SPEED2,6	VIB3	BIO2	FOOD2
KP2P-40	KE2P-40	KPHC2R-30	KFK2U-40	KE3K-50	KP3N-30	KPE2K-30	KPF2K-30
Calcium polycarbamide with EP additives	Lithium complex soap	Polycarbamide with EP additives	PTFE	Polycarbamide	Lithium complex soap with EP additives	Lithium/calcium soap	Aluminium complex soap
PAO oil	Ester oil	PAO/ester oil	Fluoro polyether oil	PAO/ester oil	Mineral oil	Ester oil	White oil
130	ISO VG 150	ISO VG 460	400	ISO VG 22	170	58	192
2	2	2	2	2-3	3	2	2
-40...+160	-40...+160	-35...+180	-40...+260	-50...+120	-30...+150	-30...+120	-30...+120
90	110	120	200	80	90	80	70
Special grease for ball and roller bearings	Special grease for ball and roller bearings	Special grease for ball and roller bearings	Special grease for ball and roller bearings	Special grease for ball bearings	Special grease for ball and roller bearings	Special grease for ball and roller bearings	Special grease for ball and roller bearings
in couplings, electric motors, automotive engineering	in electrical equipment, automotive engineering	in continuous casting plant	in track rollers in baking machinery, piston pins in compressors, kiln trucks, chemical plant	in machine tools, instruments	in blade adjusters in rotors for wind turbines, packaging machinery, rail vehicles	in environmentally hazardous applications	in applications with food contact; H1 to USDA
at high temperatures, high loads	at high temperatures, high speeds	at high temperatures, high loads	at very high temperatures, in chemically aggressive environment	at very high speeds, low temperatures	at high temperatures, high loads, with oscillating motion		
++	++	+	++	++	+	+	+
+	++	++	++	0	+	0	-
0	+	-	--	++	-	0	0
0	0	++	+	--	+	0	0
0	0	0	-	-	++	0	0
0	0	0	0	0	0	0	0
0	0	0	0	+	-	+	++

Products · Lubrication

Lubrication systems

Motion Guard · Motion Guard SELECT MANAGER

Automatic FAG lubricators Motion Guard

Reliable and economical lubrication for a long bearing life

Rolling bearings are reliable machine components that give a long operating life. The most frequent cause of failure is inadequate or incorrect lubrication. Approximately 90% of all bearings are lubricated with grease. Providing a reliable supply of suitable grease is therefore particularly important.

If an automatic lubricator is used for controlled relubrication, a sufficient quantity of fresh grease is continuously supplied to the contact points of the rolling bearing.

This results in a significant increase in bearing life. These reliable, economical devices give extended lubrication and maintenance intervals and also prevent under-supply or oversupply of grease.

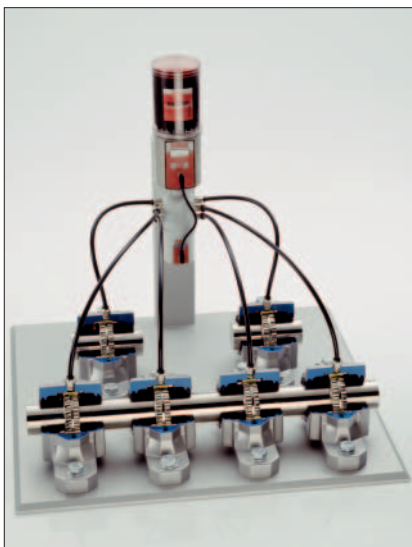

Plant downtime and maintenance costs are reduced as a result.

The sparing and environmentally friendly use of lubricants contribute to higher cost-efficiency.

FAG Motion Guard lubricators are individually matched to the bearing location and eliminate the need for costly central lubrication systems. They have a wide range of applications, for example on pumps, compressors and fans, in conveying equipment, vehicles etc.

The single point lubrication systems Motion Guard COMPACT can be used to dispense eight of the Arcanol greases described on pages 46 to 47, while CHAMPION can dispense all these greases. Motion Guard CONCEPT6 is used as a single point or multi-point lubrication system with thirteen Arcanol greases.

Advantages of lubricators

- Individually configured, precise supply to each bearing position immediately after initial operation
- Fully automatic, maintenance-free operation
- Savings on personnel costs compared to manual relubrication
- Various dispensing times can be selected (1, 3, 6 or 12 months; for CONCEPT6: 1 day to 24 months)
- No risk of confusion or contamination of lubricants
- Pressure build-up to 4 bar (COMPACT), to 5 bar (CHAMPION) or to 25 bar (CONCEPT6), thus overcoming any obstructions
- Suitable for connection to the FAG monitoring system Easy Check
- Comprehensive range of accessories

Motion Guard SELECT MANAGER

The software Motion Guard SELECT MANAGER Version 2.0 allows:

- selection of lubricators
- definition of dispensing times and relubrication quantities
- selection of suitable/preferred Arcanol greases
- management of a lubrication and maintenance plan

Detailed information on FAG automatic lubricators is given in publication WL 81 122.

Products · Lubrication

Lubrication systems

Motion Guard COMPACT · Lubricators and activation screws

FAG lubricator Motion Guard COMPACT

This automatic lubricator is electrochemically driven. The electrolyte is environmentally friendly citric acid.

The metal housing is filled with 120 cm³ of FAG Arcanol rolling bearing grease.

The dispensing time is determined by the different coloured activation screws.

Automatic lubricators Motion Guard COMPACT are available with suitable lubricants as standard in packs of 10 containers.

Ordering examples:

ARCALUB-LOAD400

(filled with LOAD400, pack of 10 containers without activation screw)

ARCALUB-TEMP90

(filled with TEMP90, pack of 10 containers without activation screw)

COMPACT lubricators filled with Arcanol MULTITOP and MULTI2 are also available in single packs including activation screws, while those with TEMP200 are only supplied in single packs with activation screws.

Ordering examples:

ARCALUB-MULTITOP-1M

(filled with MULTITOP, including activation screw for 1 month)

ARCALUB-MULTI2-3M

(filled with MULTI2, including activation screw for 3 months)

ARCALUB-MULTITOP-6M

(filled with MULTITOP, including activation screw for 6 months)

ARCALUB-TEMP200-12M

(filled with TEMP200, including activation screw for 12 months)



ARCALUB-TEMP200-6M

Arcanol

Suitable Arcanol greases, chain oils and activation screws

	1M	3M	6M	12M
MULTITOP	•	•	•	
MULTI2	•	•	•	
LOAD400	•	•	•	•
LOAD1000	•	•	•	•
TEMP90	•	•	•	•
TEMP120	•	•	•	•
TEMP200	•	•	•	•
FOOD2	•	•	•	•
CHAINOIL	•	•	•	•

Activation screws

Ordering designations (10 pieces):

ARCALUB.ACTIVE-1M

for 1 month (yellow)

ARCALUB.ACTIVE-3M

for 3 months (green)

ARCALUB.ACTIVE-6M

for 6 months (red)

ARCALUB.ACTIVE-12M

for 12 months (grey)
(12M **cannot** be used for MULTITOP and MULTI2)



Products · Lubrication

Lubrication systems

Motion Guard COMPACT · Variants CLEAR and POLAR

Variant CLEAR

The variant CLEAR of the lubricator Motion Guard COMPACT is suitable for explosion-protected and corrosion-inducing humidity areas. The lubricator can be used at operating temperatures from 0 to +40°C. The upper temperature limit is determined by the transparent plastic housing with a volume of 100 cm³.

Ordering example:

ARCALUB-CLEAR-FOOD2

(filled with FOOD2, pack of 10 containers without activation screw)

In addition to FOOD2, seven other Arcanol grease grades as listed for COMPACT on page 49, as well as chain oil can be used.

The special activation screws for the variant CLEAR with dispensing times of 1, 3 or 6 months are offered separately.

Ordering designation (10 pieces):

ARCALUB.ACTIVE-CLEAR-1M
ARCALUB.ACTIVE-CLEAR-3M
ARCALUB.ACTIVE-CLEAR-6M



Variant POLAR

The variant POLAR of the lubricator Motion Guard COMPACT is designed for operation in temperatures from -25 °C to +10 °C. The metal housing is filled with 120 cm³ of Arcanol rolling bearing grease MULTITOP (it is only available with this grease).

Ordering designation:

ARCALUB-POLAR-MULTITOP

(filled with MULTITOP, pack of 10 containers without activation screw)

For the dispensing time as a function of the actual temperature present, see the following table.

Variant POLAR

Temperature	Dispensing time
+10 °C	1 week
± 0 °C	2 weeks
-10 °C	6 weeks
-20 °C	14 weeks
-25 °C	26 weeks

The black activation screw must be ordered separately.

Ordering designation (10 pieces):

ARCALUB.ACTIVE-POLAR



Products · Lubrication Lubrication systems

Motion Guard CHAMPION · Lubricator drives, LC units, sets and accessories

FAG lubricators Motion Guard CHAMPION

The automatic lubricator Motion Guard CHAMPION is electromechanically driven. The robust, electronically controlled geared motor can be used more than once. It allows the dispensing times to be adjusted depending on the temperature and to 1, 3, 6 or 12 months. It is battery powered and the battery set is replaced whenever the cartridge is changed.

Ordering designation:
ARCALUB.DRIVE

Special drive units are available as accessories for machine-controlled operation in explosion hazard areas.

The lubricator Motion Guard CHAMPION is suitable for all the Arcanol rolling bearing greases described on page 46–47 as well as chain oil. Filled LC (Lubricant Cartridge) units with a dispensing volume of 60, 120 and 250 cm³ are available and are screwed onto the drive unit. Once the LC unit is empty, it cannot be refilled.

Ordering examples
(one battery set is included in the delivery):

ARCALUB.LC60-MULTITOP
(filled with MULTITOP, 60 cm³)
ARCALUB.LC120-LOAD400
(filled with LOAD400, 120 cm³)
ARCALUB.LC250-VIB3
(filled with VIB3, 250 cm³)

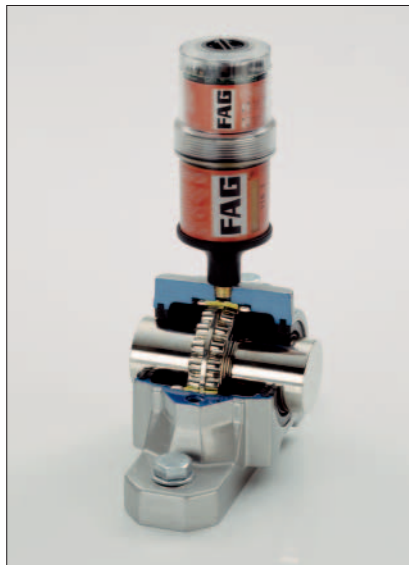

The complete lubricator, comprising a drive unit, LC unit and battery set, is connected to the lubrication point by means of an adapter or hose.

Ordering designations:
ARCALUB.ADAPTER

ARCALUB.TUBE
(3 m hose with connectors)



FAG lubricator sets Motion Guard CHAMPION

The automatic lubricator Motion Guard CHAMPION in sizes 120 and 250 cm³ and filled with Arcanol MULTITOP is offered as a complete lubricator set. The sets comprise:

- a drive unit
- an adapter
- an LC unit with battery set

Ordering designations:
ARCALUB.LC120-MULTITOP-KIT
ARCALUB.LC250-MULTITOP-KIT

The lubricator CHAMPION has only been tested in conjunction with Arcanol lubricants.

By agreement, FAG also supplies the lubricator CHAMPION with special fillings.

Accessories for Motion Guard COMPACT and CHAMPION

The Motion Guard product range is supplemented by a comprehensive range of accessories. For detailed information, see publication WL 81 122.

Products · Lubrication Lubrication systems

Motion Guard CONCEPT6

FAG lubrication system Motion Guard CONCEPT6

This **single-point and multi-point lubrication system** can supply up to six lubrication points with lubricant constantly, precisely and regardless of temperature. The dispensing times can be adjusted to between 1 day and 24 months and LC units are available in sizes 250 and 500 cm³.

FAG starter kits Motion Guard CONCEPT6

The starter kits are premounted on a retaining plate and form the basis for the multi-point lubrication system Motion Guard CONCEPT6.



The patented distribution system MP-6 allows independent supply of between two and six lubrication points.

The geared motor in the MP-6 is powered and controlled by the drive unit.



Lubricant is distributed independent of its consistency or solid particle content. If the distributor identifies an obstruction in an individual outlet, this is indicated on the display of the drive unit. The other outlets continue to be supplied.

Ordering designations:
ARCALUB-C6-250-KIT
ARCALUB-C6-500-KIT

Only the following must be ordered specially: hose and connectors for the lubrication point and LC units in sizes 250 cm³ and 500 cm³.

LC units are available with the 13 suitable Arcanol grease grades (see page 46–47, except for MULT13 and VIB3).

Ordering examples:
ARCALUB-C6.LC250-MULTITOP
ARCALUB-C6.LC250-LOAD400
ARCALUB-C6.LC500-SPEED2,6
ARCALUB-C6.LC500-TEMP200

By agreement, we supply LC units with other greases whose suitability has been checked.

Variant CONTROL

The variant CONTROL of the lubricator CONCEPT6 is controlled by the machine, i.e. lubricant is only dispensed while the machine is running. We also supply starter kits for the variant CONTROL as a basis for multi-point lubrication systems.

Ordering designation:
ARCALUB-C6-CONTROL-250-KIT
ARCALUB-C6-CONTROL-500-KIT



For **single-point lubrication**, the parts required are ordered individually from the range of accessories.



For detailed information, see publication WL 81 122.

Products · Lubrication Lubrication systems

Grease metering devices · Grease gun

FAG grease metering devices

These devices are used for the metered greasing of rolling bearings. The metering range is between 10 and 133 cm³. Larger metering ranges can also be achieved by operating the device several times. By means of a pneumatically driven, double direction piston pump, the medium is conveyed directly from the grease container (25 kg or 180 kg) via the metering valve to the application point.

The grease metering device comprises:

- a cover
- a piston
- a metering valve
- a hose connecting the pump and valve
- a 2,5 m hose
- a grease gun

Technical data:

Pump ratio: 10 : 1
 Delivery quantity: 400 cm³/min
 Metering range: 10–133 cm³

Ordering designations:

ARCA-PUMP-25
ARCA-PUMP-180



ARCA-PUMP-180

FAG grease gun with reinforced hose

In difficult operating conditions or aggressive environments, rolling bearings must be frequently relubricated via lubrication nipples. With the FAG grease gun and the matching reinforced hose, this operation can be carried out easily, cleanly and quickly. The parts comply with DIN 1283.



ARCA-GREASE-GUN with
 ARCA-GREASE-GUN.HOSE and
 ARCA-GREASE-GUN.HOOK-ON-HOSE

Grease gun

Container diameter 56 mm
 Total length of gun 390 mm
 Delivery quantity 2 cm³/stroke
 Pressure max. 800 bar

The gun can either be filled with bulk grease or fitted with a cartridge to DIN 1284.

- 500 cm³ container volume with bulk grease or
- 400 g cartridge to DIN 1284 (diameter 53,5 mm, length 235 mm)

Connector thread G¹/₈
 Mass approx. 1,5 kg

Ordering designation:
ARCA.GREASE-GUN

Reinforced hose

Length 300 mm
 Connector thread G¹/₈
 Fitted with hydraulic grip coupling for taper type lubrication nipple to DIN 71412

In place of the hydraulic grip coupling, slide couplings for flat lubrication nipples to DIN 3404 or other nozzles can be connected. These connectors are available from normal trade outlets.

Ordering designation:
ARCA-GREASE-GUN.HOSE

A hose with a connector for cylindrical nipples to DIN 3404 is optionally available.

Ordering designation:
ARCA-GREASE-GUN.HOOK-ON-HOSE

Products · Alignment



Belt and chain drives 56

Belt pulley alignment device 56

Belt tension measuring device 57

Shaft couplings 58

Shaft alignment device 58

Accessories for alignment 60

Shims 60

Products · Alignment Belt and chain drives

Belt pulley alignment device

FAG belt pulley alignment device Top-Laser SMARTY2

Top-Laser SMARTY2 is an economical measuring device for the alignment of belt pulleys and chain sprockets. Through the use of this device, the wear of belt drives, bearings and seals is reduced. Less vibration is generated and the running time and reliability of the machinery is increased.

Features and advantages:

- Parallelism and misalignment of both pulleys displayed
- Significantly quicker and more precise than conventional methods
- Suitable for both horizontally and vertically mounted machinery
- Only one person required for alignment
- Also suitable for non-magnetic sprockets or pulleys

The measuring device can be mounted in just a few seconds. The laser beam can be clearly seen on the target marks. Once the laser beam is adjusted to coincide with the slots in the target marks, the machine is correctly aligned. The target marks are available in

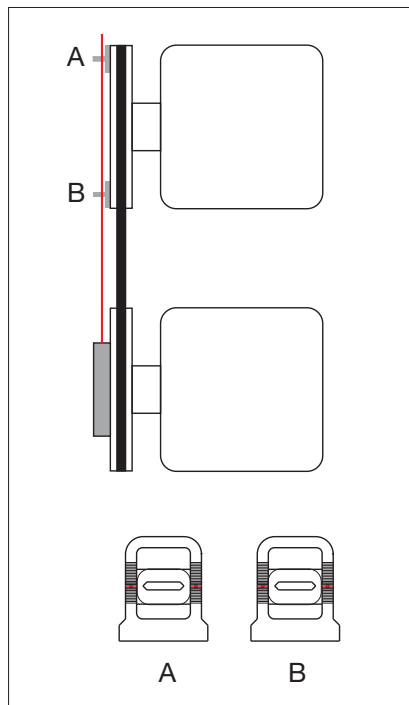

optical and digital form. In the case of the digital target mark, adjustment values are shown in the display in real time. Misalignments are presented in degrees and the parallelism offset in mm. Since the measuring instrument is so light, the emitter and target marks can be easily attached to non-magnetic drive pulleys using a strong, double-sided adhesive tape.

Ordering designation and scope of delivery:

Complete laser measuring device incl.

2 optical target marks,
2 batteries and user manual in padded case:

LASER-SMARTY2

Replacement part:

1 optical magnetic target mark
LASER-SMARTY2.TARGET

Accessories:

1 digital magnetic target mark
LASER-SMARTY2.TARGET-DIGITAL

For detailed information, see TPI WL 80-55.



Products · Alignment Belt and chain drives

Belt tension measuring device

FAG belt tension measuring device Top-Laser TRUMMY2

The robust, handy Top-Laser TRUMMY2 is an optical-electronic instrument for measuring and setting optimum belt tension (strand force).

Optimum belt tension, like precise alignment of the belt pulleys (see Top-Laser SMARTY2, page 56), is an essential precondition for achieving the maximum possible life of the belt drive. There is also less wear of the drive components, energy costs are reduced and cost-effectiveness is increased. The user-friendly Top-Laser TRUMMY2 can be used in many locations and comprises a cableless measurement probe, a measurement

probe with a cable for difficult to access locations and a microprocessor that indicates relevant measurables for belt tension either as frequency [Hz] or force [N]. By means of an impulse (for example by striking the stationary belt), the tensioned belt is excited to natural vibration. The individual static natural frequency thus generated is measured within seconds by the TRUMMY2 sensor using clock pulse light and displayed. In order to calculate the strand force of the belt drive, the belt mass and length are entered in the microcomputer before measurement. TRUMMY2 uses these to calculate the strand force, which is then compared with the specified nominal value.

In comparison with systems operating for example by sound waves, this new measurement technique using clock pulse light is clearly superior, since the measurement result cannot be distorted by disruptive influences. The simple and reliable user instructions are given in several languages.

Ordering designation:
Laser measuring device in plastic case:

LASER-TRUMMY2

For detailed information, see
TPI WL 80-55.



Products · Alignment Shaft couplings

Shaft alignment device

FAG shaft alignment device Top-Laser INLINE

The FAG Top-Laser INLINE is a PC-based alignment system for coupled shafts in motors, pumps, ventilators and gearboxes (with rolling bearings).

Operating benefits:

- Simple to mount
- Error-free handling even by untrained personnel due to automatic measurement and positioning process
- More precise alignment than with conventional methods
- Rapid measurement due to continuous rotary motion
- Reduced vibration and friction losses
- Longer machine running times
- Usable with conventional laptops

Included in delivery:

- 1 transceiver
(incl. 3 m cable)
- 1 reflector
- 2 brackets
- 2 chains (300 mm)
- 4 posts (115 mm)
- 1 software
- 1 case
- 1 serial PC card

All the parts included in the delivery are also available as replacement parts.

Ordering designation:
Complete Top-Laser INLINE:
LASER-INLINE

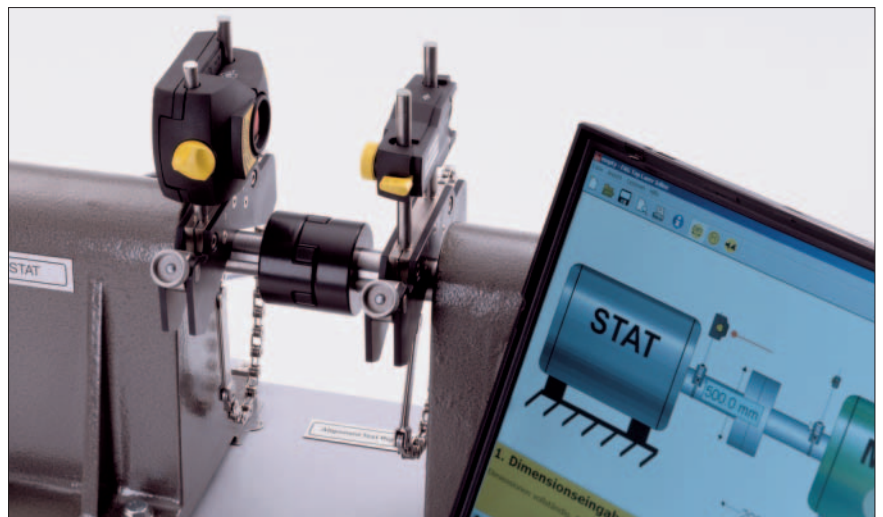
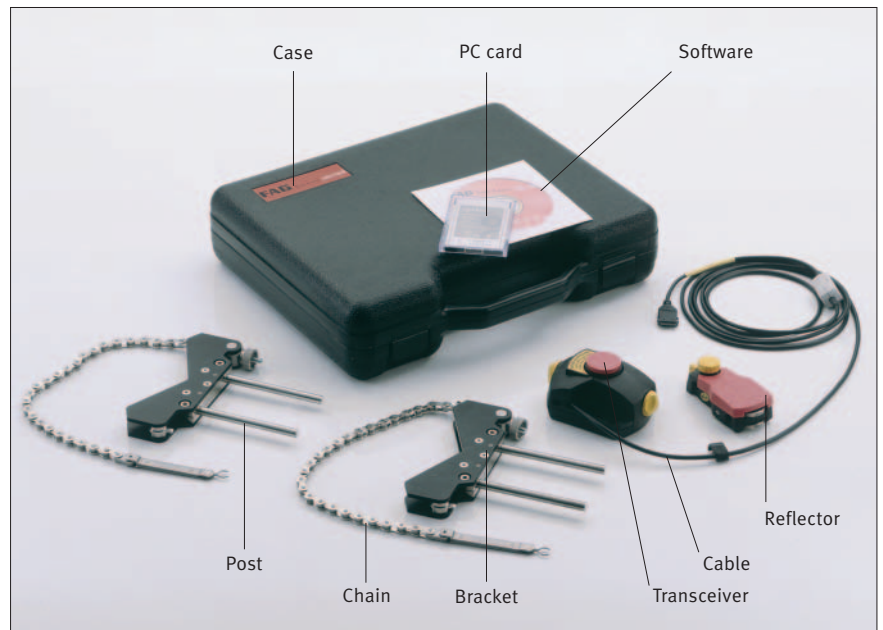

Actions before alignment

Before any alignment operation, any tilting foot (machine foot that lifts off the floor when slackened) should be removed in order to prevent increased vibration tendency and bearing damage due to housing distortion.

The Top-Laser INLINE helps to quickly identify and eliminate the so-called soft foot. It is only necessary to loosen each individual screw foot connection. The computer determines any foot movement. The tilting foot can then be eliminated using shims.

Products · Alignment Shaft couplings

Shaft alignment device

Accessories

The possible applications of the LASER-INLINE basic device can be expanded with the aid of a comprehensive range of accessories (see table). The accessories can be ordered as a set in a handy, robust case or – individually compiled – as individual parts.

For detailed information, see TPI WL 80-55.

Accessories for LASER-INLINE		
Accessories for LASER-INLINE	Included in delivery	Ordering designation
Accessory set, complete	1 piece	LASER-INLINE.ACCESS-SET
Chain, 600 mm long	2 pieces	LASER-INLINE.CHAIN600
Chain, 1 500 mm long	2 pieces	LASER-INLINE.CHAIN1500
Post, 150 mm long	4 pieces	LASER-INLINE.POST150
Post, 200 mm long	4 pieces	LASER-INLINE.POST200
Post, 250 mm long	4 pieces	LASER-INLINE.POST250
Post, 300 mm long	4 pieces	LASER-INLINE.POST300
Magnetic holder	2 pieces	LASER-INLINE.MAGNET
Accessory case, empty	1 piece	LASER-INLINE.CASE-ACCESSORIES

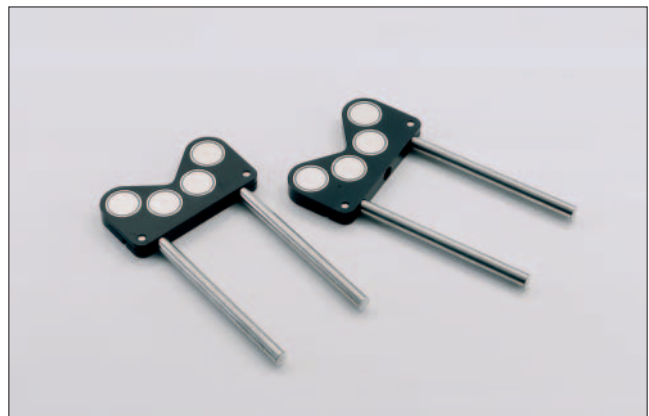

Products · Alignment Accessories

Shims

FAG shims Top-Laser SHIM

Top-Laser SHIMs are used to eliminate any vertical misalignment detected using the FAG Top-Laser devices. These shims are available in seven thickness values (0,05; 0,10; 0,20; 0,50; 0,70; 1,00; 2,00 mm) and four sizes (dimension C = 15, 23, 32 or 44 mm).

Composition of set

The practical case contains 20 shims each of 3 sizes (C = 15, 23 and 32 mm) and 6 thickness values (0,05 to 1,0 mm), i.e. a total of 360 shims, together with one extraction hook.

Ordering designation:

LASER.SHIM-SET

Individual or replacement parts

As replacement parts, we supply 10 shims each of one of the 4 sizes and one of the 7 thickness values stated above.

Ordering examples:

10 shims of dimension C = 15 mm and 0,20 mm thickness:

LASER.SHIM15X0,20

10 shims of dimension C = 44 mm and 0,10 mm thickness:

LASER.SHIM44X0,10

For detailed information, see TPI WL 80-55.

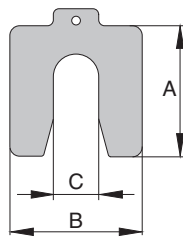
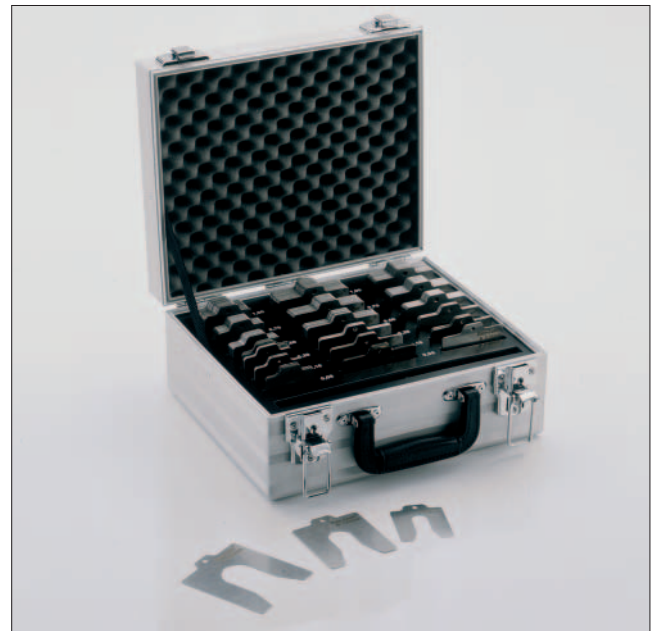

LASER.SHIM-SET

Ordering designation Set FAG	Dimensions			Thickness	Total quantity of shims	Mass kg
	A	B	C			
LASER.SHIM-SET	55	50	15	0,05–1,0	360	6,7
	75	70	23	0,05–1,0		
	90	80	32	0,05–1,0		

LASER.SHIMs Individual or replacement parts

Ordering designation Individual or replacement parts FAG	Dimensions			Thickness	Total quantity of shims	Mass g
	A	B	C			
LASER.SHIM15X...	55	50	15	0,05–2,0	10 each	11–440
LASER.SHIM23X...	75	70	23	0,05–2,0	10 each	21–840
LASER.SHIM32X...	90	80	32	0,05–2,0	10 each	29–1 160
LASER.SHIM44X...	125	105	44	0,05–2,0	10 each	53–2 100

Products · Condition monitoring



Operating condition 62

Temperature measuring devices	62
Digital hand tachometer	63
Sonar device	64

Vibration diagnosis 65

Detector II	65
Detector III	66
Easy Check	67
Easy Check Online	67
DTECT X1	67
WiPro	68
VibroCheck	69
ProCheck	70

Products · Condition monitoring Operating condition

Temperature measuring devices

FAG infrared thermometer TempCheck PLUS

The FAG infrared thermometer TempCheck PLUS measures the infrared radiation emitted by an object and uses this to calculate the surface temperature. The contact-free measurement makes it possible to easily determine the temperature of difficult to reach or moving objects.

The device is very light (it weighs only 150 g) and can be taken practically anywhere it is needed. The FAG infrared thermometer TempCheck PLUS can measure temperatures in a range between -32°C and $+530^{\circ}\text{C}$. It has high precision glass optics for accurate contact-free temperature measurement. It is suitable for monitoring the temperature of components of a machine.

Overview of the advantages of TempCheck PLUS:

- Rapid and precise temperature measurement
- State of the art infrared temperature measurement technology
- Simple to use
- Reduction of unplanned downtime
- Low purchase cost

Ordering designation and scope of delivery:

TEMP-CHECK-PLUS
(measuring device with battery, strap, user manual and carry case)

Caution

Do not look into the laser beam. Do not point the laser beam into other people's eyes.



FAG temperature measuring device TempCheck CONTACT

This handy device has a display range from -60°C to $+1000^{\circ}\text{C}$. The surface temperature sensor TEMP-CHECK-CONTACT.SENSOR has a measurement range from -60°C to $+300^{\circ}\text{C}$.

The device is suitable for measuring the temperature of

- rolling bearings, housings and lubrication systems for operational monitoring
- heated rolling bearings and joints during mounting

The microprocessor-controlled measuring device has a single line display. The touch keyboard has

the following switching functions:

- On/Off
- Hold
(hold the measurement value in the display)

Ordering designation and scope of delivery:

TEMP-CHECK-CONTACT
(measuring device with sensor TEMP-CHECK-CONTACT.SENSOR and service case)

FAG temperature sensor as replacement part

(can be ordered individually):
Rapid reaction surface sensor
Ordering designation:
TEMP-CHECK-CONTACT.SENSOR

FAG temperature sensor as accessory

(can be ordered individually, for measuring the temperature of fluids, lubricants etc.):

Immersion/insertion sensor

Ordering designation:

TEMP-CHECK-CONTACT.SENSOR-IMMERSION



For detailed information, see TPI WL 80-54.

Products · Condition monitoring Operating condition

Digital hand tachometer

FAG digital hand tachometer TACHOMETER

The speed counter is suitable for two types of operation:

- Direct speed measurement using an adapter, track wheel and measurement stylus
- Non-contact optical speed measurement using a reflective mark

Direct speed measurement

For direct speed measurement, the supplied adapter must be fitted.

Through contact with the component, the rubber stylus measures the speed or the surface speed is determined in conjunction with a track wheel.

Non-contact speed measurement

For non-contact measurement, a reflective mark is applied to the machine part to be measured. This mark is detected by photoelectric means using visible red light. The device displays the speed in revolutions per minute.

Ordering designation:
TACHOMETER

Included in delivery:

- Digital hand tachometer
- Adapter for direct measurement 1:1
- Track wheel, 6 inch
- Rubber stylus
- 10 reflective marks
- User manual
- Case

Replacement parts

10 reflective marks
Ordering designation:
TACHOMETER.MARKS-REFLEX



Products · Condition monitoring Operating condition

Sonar device

FAG sonar device SOUND-CHECK

The sonar detector can be used to check rolling bearing noise very easily, quickly and reliably. Changes in noise due to wear, pitting formation or distortion of the bearing can be detected at an early stage if regular inspection is carried out. In this way, unforeseen operational downtimes and more significant machine damage can be prevented. The device is used in the same way as a doctor's stethoscope.

The tips of the earpiece are placed in the ear canals to provide insulation against background noise. The insulating grip is held like a pencil between index finger and thumb and the sensor is placed firmly on the part to be measured. If a noise is heard, the sensor is moved until its volume reaches a maximum.

Ordering designation:

SOUND-CHECK



Products · Condition monitoring Vibration diagnosis

Detector II

Condition monitoring by vibration diagnosis

Vibration diagnosis is the most reliable method for identifying machine damage at an early stage. Imbalance and misalignment defects can be detected accurately, as well as rolling bearing damage and gear tooth defects. For this area, we therefore offer a comprehensive product portfolio, ranging from simple vibration monitors to complex monitoring systems with a large number of measuring points. FAG vibration measuring devices help to plan maintenance work, extend bearing life, reduce costs and increase plant availability.

In the field of **offline monitoring devices**, we offer Detector II and Detector III.

The **online monitoring devices** include products from the economical Easy Check range, the digital vibration monitors DTECT X1 and WiPro as well as the online monitoring systems VibroCheck and ProCheck.

For all these devices and on all aspects of condition monitoring, F'IS offers a worldwide service – from the F'IS Customer Hotline to customer-specific service contracts. In order to achieve optimum networking, all online systems have versatile communication options as standard.

FAG Detector II

Detector II is a portable vibration measuring device and data collector in one. Using this economical device is straightforward and easy to learn. It weighs approx. 450 g and is highly suitable for monitoring extensive plants where measurement rounds involving large distances must be covered. Detector II picks up vibration signals at predetermined measuring points and calculates the effective values for vibration rate and acceleration. It can be used to monitor machine vibrations in accordance with ISO 10816 as well as the rolling bearing condition using the demodulated signal detection method. Temperatures can also be measured by non-contact means using an infrared sensor. The data collected by the device are transferred to a computer. They are then evaluated, analysed and presented in graphic form with the aid of the software Trendline. Any incipient damage can thus be detected at an early stage. Detector II can also be used by personnel who have no experience of vibration measurement. A very useful feature in this respect is the “e-mail button”. This allows the collected data to be sent to an

external diagnosis expert for further analysis.

Included in delivery:

- Basic device with rechargeable battery
- Acceleration sensor with magnetic foot
- Temperature sensor
- Power pack
- PC data cable
- User manual
- Protective bag with holder for temperature sensor
- PC software Trendline
- Case
- USB serial adapter

Accessories:

- Second attachable bag for holding acceleration sensor
- Sensor extension cables for lengths of 5 m and 15 m are available on request

Ordering designation:

DETECT2-1MB-KIT

For detailed information, see TPI WL 80-62.

Please direct enquiries to: info@fis-services.com



FAG Detector II

Products · Condition monitoring Vibration diagnosis

Detector III

FAG Detector III

Detector III is based on the successful Detector II. The proven, simple operating concept was retained and supplemented by a large number of new functionalities. In addition to vibration measurement, contact-free temperature measurement and data collection, the system is now also capable of carrying out static and dynamic balancing tasks. As a result, imbalance can not only be detected but easily and efficiently eliminated. For this purpose, the optionally available **Balancing Kit** is required. With the aid of the software installed on the system, the user is guided through the balancing procedure step by step. The results of the balancing procedure as well as the vibration measurement are transferred to the software F'IS Trendline where they are analysed and evaluated. The completely revised F'IS Viewer offers the user a large number of functions that make data analysis considerably easier. In particular, the newly integrated bearing database containing approx. 20 000 bearings from various manufacturers gives more simple and more efficient analysis of the measured data. As a result, it is very easy to compare the measured data with possible damage frequencies. A completely new feature is the optional functionality of automatic detection of measuring points.* RFID tags are applied at the measuring points and are thus detected automatically by the system. This contributes not only to prevention of errors but also to optimisation of measuring time.

Further highlights of the system:

- an expanded memory capacity, allowing storage of up to 1600 measurement points and at the same time up to 270 time signals
- the speed measurement function
- and the revised report generator system

Ordering designation:

DETECT3-KIT

Included in delivery:

- Basic device with rechargeable battery
- Acceleration sensor with magnetic foot
- Temperature sensor
- Charger
- PC data cable (serial/USB)
- User manual
- Protective bag with holder for temperature sensor
- PC software Trendline
- Case

Ordering designation:

DETECT3-KIT-RFID

Included in delivery:

- As DTECT3-KIT
- RFID reader (integrated)
- RFID tags

Ordering designation:

DETECT3.BALANCE-KIT

Included in delivery:

- Acceleration sensor with magnetic foot and sensor cable
- Trigger sensor (optical and inductive)
- Scales
- Magnetic holder for trigger sensor
- Extension for magnetic holder
- Cable for trigger sensor (length 10 m)
- Reflective mark for trigger sensor
- Dongle for activation of balancing function
- Case

Accessories

- Sensor extension cables for lengths of 5 m and 15 m are available on request.
- Further RFID tags are available on request

*This functionality is not yet available worldwide.

Please direct any enquiries to: info@fis-services.com
For detailed information, see TPI WL 80-64.



FAG Detector III and Balancing Kit

Products · Condition monitoring Vibration diagnosis

Easy Check · DTECT X1

FAG EASY Check series

The FAG Easy Check devices are economical vibration monitors for permanent monitoring of critical machinery in plants with constant operating conditions, e.g. pumps, fans, electric motors etc.

Since Easy Check vibration monitors are easy to mount and operate, they can also be used without difficulty by employees who have no knowledge of condition monitoring. The devices monitor vibration in accordance with ISO 10816, the condition of rolling bearings with the aid of the demodulated signal method and the temperature at the bearing locations.

The use of Easy Check devices can contribute to a considerable cost reduction as arising damage is detected at an early stage and the necessary work can be integrated into maintenance planning.

FAG Easy Check basic device

FAG Easy Check is a standalone device that is powered by a battery and is applied directly to the critical machine. The vibration monitor draws attention to any problem by means of LEDs (traffic light function).



FAG Easy Check basic device

The status of the LEDs on the Easy Check must be checked at regular intervals.

Ordering designation:
EASY-CHECK

FAG Easy Check Online

In contrast to the basic device, FAG Easy Check Online has an external power supply. Additional alarm outputs for vibration and temperature offer the possibility of presenting alarm conditions on a control station or traffic light device. This eliminates the need for regular inspections and allows the monitoring of difficult to access locations. Using the input, FAG Easy Check Online can be administered remotely, e.g. for resetting the alarms, starting the learning phase or activating a measurement cycle.

Ordering designation:
EASY-CHECK-ONLINE



FAG Easy Check Online

For detailed information, see TPI WL 80-68.

Please direct enquiries to:
info@fis-services.com

FAG DTECT X1

DTECT X1 allows early detection of damage by selective frequency vibration monitoring based on individually adjustable frequency bands. By means of the selective frequency method, specifically selected machine parts can be monitored. DTECT X1 has characteristics that would normally only be found on significantly more expensive systems. The system is variable and can be specially matched to the requirements of the application. The basic device is available with 2 channels, 4 channels or as an 8 channel system with an external multiplexer. All conventional acceleration, speed and travel sensors can be attached. It is possible to record process variables such as speed,



FAG DTECT X1

Products · Condition monitoring Vibration diagnosis

DTECT X1 · WiPro

temperature, torque and pressure. The signal collected by the sensor is broken down into its frequency components by means of Fast Fourier Transformation (FFT). It is thus possible to monitor amplitudes within fixed, very narrow frequency bands for specified limit values and trigger an alarm. If necessary, the remote monitoring function can be used to monitor machines without the need for a diagnosis expert on site. Any changes are automatically notified via telecommunication systems (fixed line, mobile or GSM modem) to the operating company, plant manufacturer or service provider regardless of where the system is located throughout the world. Stored and current data can be remotely retrieved and analysed by the FAG Diagnosis Centre.

For detailed information, see TPI WL 80-65.
Please direct enquiries to:
info@fis-services.com

FAG WiPro

WiPro is a cost-effective online monitoring system for the condition-based maintenance of wind turbines.

The system, certified by the AZT (Allianz Zentrum für Technik), can monitor not only the drive train (main bearing, gearbox, coupling, generator) but also vibrations in the tower. If required, other information such as rotor blade speeds or oil quality can be integrated in the condition monitoring. WiPro is equipped with a signal processor and evaluates all measurement signals in the nacelle itself. Due to the intelligent linking of expert knowledge with information from the turbine, it is possible to keep the transfer data volume very small. This is particularly important where a large number of turbines are to be monitored on a permanent basis, allowing transfer data quantities to be kept to a minimum. Due to the different communication

options, an appropriate solution can be found for any wind farm. With WiPro, the operator is kept informed at all times of the condition of the most important components. This gives a high level of investment security and active machine protection.

The modular concept of the WiPro system allows all types of wind turbines to be retrofitted with the system. Any wind farm can be networked using the WiPro system, whether the turbines are connected using copper cables, fibre optics, ISDN or analogue lines or even if no telephone connection at all is present.

For detailed information, see TI WL 80-66.

Please direct enquiries to:
info@fis-services.com



FAG WiPro

Products · Condition monitoring Vibration diagnosis

VibroCheck

FAG VibroCheck

The online monitoring system VibroCheck is ideally used wherever a large number of measuring points must be continuously and reliably monitored, such as in rolling mills, paper factories or power stations. In its most extended configuration, up to 2 048 sensors can be integrated in the system. For the detection of defects such as imbalance and misalignment, VibroCheck generates spectrum-based parameters that are managed within narrow frequency bands according to speed. In addition to general parameter monitoring, the user has available an automatic, rule-based expert system that can monitor up to 20 components per sensor. This allows monitoring of all rolling bearing types and tooth meshes in the vicinity of a sensor in relation to the occurrence of component-specific frequency windows. In addition to vibration signals, other process parameters such as temperature, power, pressure, torque etc. can also be detected.

By remote access, the data can also be analysed by external service providers or CM experts at other locations.

The display, which is individually tailored to the customer's requirements, gives a user interface that allows a rapid overview of the condition of the plant. Depending on the complexity of the plant, this display can be arranged on several levels. Through the high predictive accuracy and early identification of forthcoming damage, optimum use can be made of planned stoppages and downtimes due to failure can be drastically reduced.

For detailed information, see TPI WL 80-67.

Please direct enquiries to: info@fis-services.com



FAG VibroCheck

Products · Condition monitoring Vibration diagnosis

ProCheck

FAG ProCheck

ProCheck is the latest generation of modular concept online monitoring systems. Together with the newly developed software, the system represents a high performance solution for preventing unplanned downtime and increasing reliability. The device records vibration data, process parameters and operating data, assesses these data and provides the customer with authoritative and reliable information on the condition of his equipment.

The system is available in several configuration levels, can be expanded at any time and can be flexibly adapted to the growing requirements of the industrial environment. The customer can start with 4 monitoring channels and progressively expand the system up to 16 channels. He also has the option of correlating a large number

of analogue and digital input and output signals to his vibration data. These signals also allow simple communication with higher level systems such as process control systems. Data can thus be easily exchanged or made available. For monitoring of complex systems, ProCheck uses methods and techniques established in the market such as frequency-selective parameters, demodulated signal detection and trend monitoring.

Potential machine defects in complex units can be reliably identified by monitoring vibration in combination with other process parameters such as temperature. Counteractive measures can then be introduced in good time. Due to its flexibility, scalability and extremely robust design, this system is destined for use in all industrial segments. The system has almost no limits, whether it is used in steelworks,

paper machinery or cement plants. This is aided by its extremely compact and robust design, together with its ATEX and UL approvals.

For detailed information, see TPI WL 80-69.

Please direct enquiries to: info@fis-services.com

Further online monitoring systems

Further online monitoring systems for the requirements of specific sectors are available on request.



FAG ProCheck

Products · Maintenance management



CMMS Interface

72

Products · Maintenance management

CMMS Interface

CMMS Interface

With the CMMS* Interface, FIS offers an intelligent link between vibration measurement/analysis and the Computerized Maintenance Management System MAXIMO®. By means of a software module, the portable FAG vibration measuring device Detector and its software Trendline is linked to the Computerized Maintenance Management System MAXIMO®. In addition to the advantages of the two systems in themselves, the link created by the CMMS Interface generates the following synergy effects:

- Central storage of diagnostic and maintenance data
- Redundancy-free administration of master data
- Fully automatic generation of current routes for Detector
- Updating of follow-up orders in MAXIMO® in an alarm situation
- Build up a measurement value history in MAXIMO®



Please direct enquiries to:
info@fis-services.com

* Computerized Maintenance Management System

Services

Services relating to rolling bearings

Mounting/Repair 75

Mounting service	75
Reconditioning of rolling bearings	76
Equipment rental	78

Lubrication 79

Corrective maintenance 80

Balancing	80
Alignment	80

Condition monitoring 81

Continuous measurement (online)	81
Regular measurement (offline)	81
Troubleshooting	82
Technical consultancy	84

Maintenance management

Maintenance consultancy 86

Computerized Maintenance Management System 88

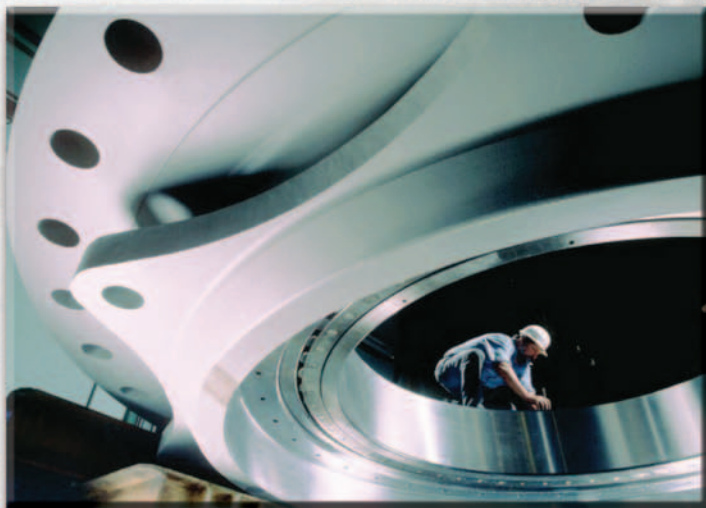

Services · Services relating to rolling bearings

F'IS defines itself as an independent full service supplier and covers the complete range of services relating to the life cycle of a rolling bearing: from mounting, through maintenance to reconditioning of rolling bearings.

During the operational phase, F'IS experts provide support through services in the field of condition monitoring and corrective maintenance. Companies that wish to build up their knowledge in the areas of rolling bearings and condition monitoring have access to the F'IS training and consultancy

portfolio. Through the association with the Schaeffler Group, customers also benefit from the expertise of a leading supplier of rolling and plain bearings.

Detailed information on the individual services is given on the following pages.



Services · Services relating to rolling bearings Mounting/Repair

Mounting service

Mounting service

The F'IS Mounting Team offers mounting services for rolling bearings across market sectors. We have extensive experience, for example, in railways, raw material mining and processing, steel and aluminium, wind power, paper, oil and gas etc.

The F'IS mounting personnel are specially trained and will provide reliable and rapid assistance. The mounting services are provided either at the customer's location or in the F'IS workshop facilities.

The mounting service includes:

- mounting and dismounting of rolling bearings of all types
- approval inspection of adjacent parts (shafts and housings)
- maintenance and inspection of bearing arrangements
- defect analysis on bearing arrangements not running satisfactorily
- advice on rationalisation of mounting operations
- design and manufacture of special tools

Operating benefits:

- extended bearing life
- considerable cost reductions
- less unplanned downtime
- increased plant availability
- improved awareness among employees of the correct handling of rolling bearings

Please direct enquiries about the services described to:

Schaeffler KG

Tel. +49 9721 91-3142 or -2573

Fax +49 9721 91-3809

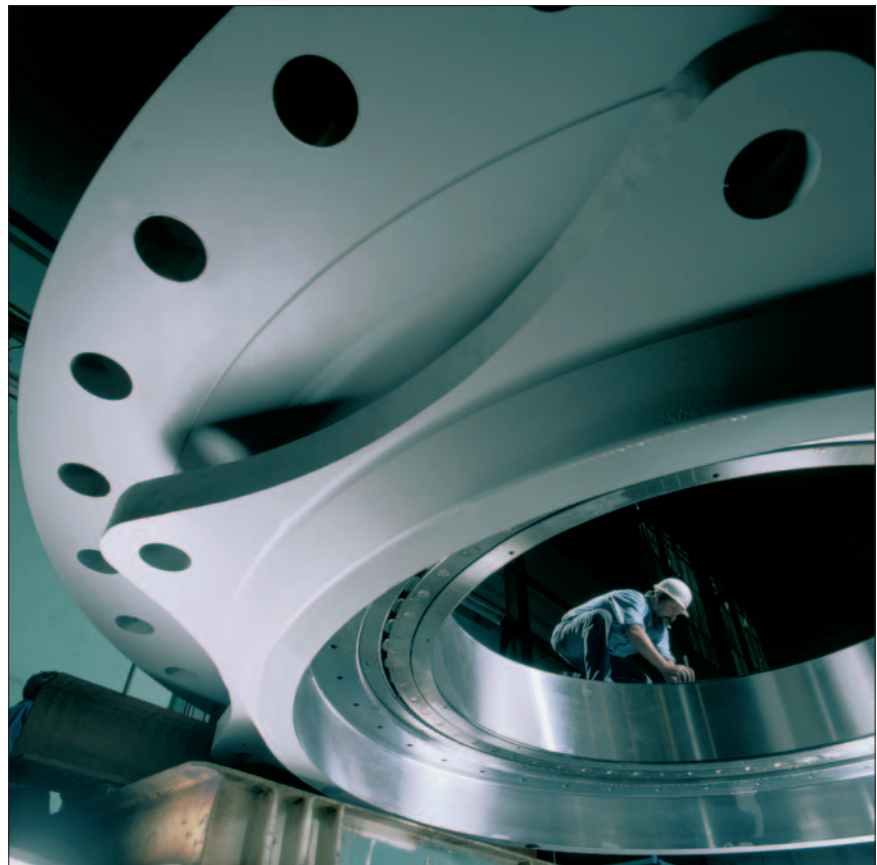

Services · Services relating to rolling bearings Mounting/Repair

Reconditioning of rolling bearings

Reconditioning of rolling bearings

Wheelset bearings for railway vehicles and standard bearings up to 425 mm outside diameter

Wheelset bearings for railway vehicles are among the most heavily loaded vehicle parts. Their life can be increased significantly by appropriate and regular maintenance. F'IS therefore offers operators of all railway vehicles the opportunity to have their wheelset bearings professionally dismantled, cleaned and reconditioned.

Customers thus benefit from the in-depth knowledge in the field of rolling bearings that is only available from a bearing manufacturer. The technical expertise of F'IS employees guarantees the highest quality in maintenance and the achievement of maximum bearing life.

The F'IS service offer applies to:

- all wheelset bearings and cylindrical, spherical and tapered roller bearings up to a maximum width of 180 mm and a maximum outside diameter of 425 mm
- products from all rolling bearing manufacturers
- all railway vehicles

The service includes:

- professional dismantling, cleaning and reconditioning of railway wheelset bearings at the F'IS Service Center in Schweinfurt (Germany)
- identification marking of each individual bearing before dismantling
- if required, bearing-specific documentation of all maintenance activities carried out

Operating benefits:

- longer life of railway wheelset bearings due to high quality maintenance work
- short downtime periods due to swift implementation of the maintenance process
- minimal mounting work, since the wheelset bearings are returned in a condition ready for mounting
- reduced maintenance costs due to preventive maintenance

Please direct enquiries about the services described to:

Schaeffler KG

Georg-Schäfer-Strasse 30
97421 Schweinfurt (Germany)
Tel. +49 9721 91-1919
Fax +49 9721 91-3809

For detailed information, see
TPI WL 80-72



Large rolling bearings of outside diameter >425 mm

The statements on wheelset bearings and standard bearings up to an outside diameter of 425 mm can also be applied to larger standard and special rolling bearings. Within the framework of maintenance activities, rolling bearings are still replaced for reasons of safety that could be restored to an acceptable and functional condition through appropriate cleaning and reconditioning. In general, the costs of such reconditioning are significantly lower than the costs of a new bearing – with shorter delivery times in most cases. In individual cases, customers may also receive the same warranty on the reconditioned bearing as on a new bearing.

The F'IS experts repair all types of rolling bearings such as cylindrical roller bearings, spherical roller bearings, tapered roller bearings etc.

They first carry out a damage diagnosis on the basis of which it is decided whether repair is viable and which level of reconditioning is required on the rolling bearing.

For detailed information, see
WL 80 151.

Please direct enquiries to:

Schaeffler KG

Mettmanner Strasse 79
42115 Wuppertal (Germany)
Tel. +49 202 293-2226
Fax +49 202 293-2437

Services · Services relating to rolling bearings

Mounting/Repair

Reconditioning of rolling bearings

Overview of the individual stages in reconditioning of rolling bearings

Assessment – Inspection	Level I – Requalifying	Level II – Refurbishment	Level III – Remanufacturing	Level IV – Remanufacturing Plus
<p>Dismounting</p> <p>Washing</p> <p>Examination</p> <p>Definition of repair operations</p> <p>Preparation of proposal</p>	<p>Measurement</p> <p>Mounting</p> <p>Preservation, greasing if appropriate</p> <p>Packaging, long term packaging if appropriate</p> <p>Despatch</p>	<p>Polishing of raceways</p> <p>Removal of fretting corrosion</p> <p>Mounting</p> <p>Preservation, greasing if appropriate</p> <p>Packaging, long term packaging if appropriate</p> <p>Despatch</p>	<p>E.g.</p> <p>Regrinding of raceways</p> <p>Manufacture of new rolling elements</p> <p>Replacement of cage if appropriate</p> <p>Removal of fretting corrosion</p> <p>Mounting</p> <p>Preservation, greasing if appropriate</p> <p>Packaging, long term packaging if appropriate</p> <p>Despatch</p>	<p>E.g.</p> <p>Regrinding of raceways</p> <p>Manufacture of inner ring with new bore diameter</p> <p>Redimensioning of internal clearance</p> <p>Manufacture of new rolling elements</p> <p>Replacement of cage if appropriate</p> <p>Removal of fretting corrosion</p> <p>Mounting</p> <p>Preservation, greasing if appropriate</p> <p>Packaging, long term packaging if appropriate</p> <p>Despatch</p>



Services · Services relating to rolling bearings Mounting/Repair

Equipment rental

Equipment rental

Customers who require special mounting and measuring equipment only occasionally, for example in order to carry out repairs, can rent these from F'IS on a weekly basis for a fee.

FAG Industrial Services primarily rents

- taper gauges
- enveloping circle gauges
- hydraulic nuts
- hand pump sets
- heating devices

The equipment is stored at our mounting workshop and its function is checked and maintained by our mounting specialists.

Please direct enquiries about this service to

Schaeffler KG

Tel. +49 9721 91-1133

Service Hotline:

Tel. +49 2407 9149-99

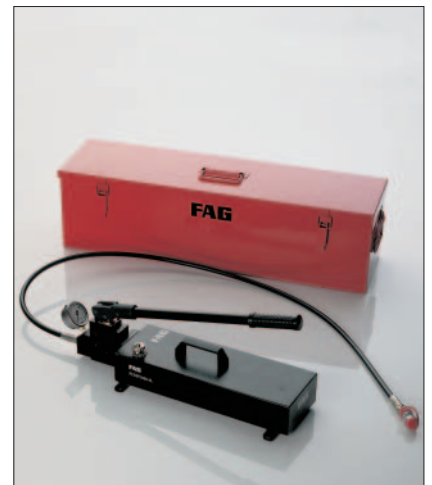

Services · Services relating to rolling bearings Lubrication

Lubrication as a service

In more than half of all cases, inadequate lubrication is the cause of unplanned machine downtime.

The use of suitable greases for different operating and environmental conditions as well as know-how in when, how frequently and with what quantities bearings should be lubricated, makes it possible to significantly extend the life of rotating machine elements.

Specialised employees offer their service across market sectors and have special experience, for example in the areas of railway/transport, power transmission, steel and aluminium, paper, wind power, agriculture and forestry, the food and delicacies industry as well as mining and processing technologies. F'IS services include the selection and installation of lubricants and lubrication systems, the lubrication of bearing positions, the preparation of lubrication and maintenance plans, lubrication point management, lubrication consultancy and lubricant investigations and tests.

A comprehensive selection of high quality FAG Arcanol greases specially tested and selected for use in rolling bearings is available. The consistent quality of Arcanol lubricants is ensured by ongoing investigation on special test rigs. The use of names that are easily remembered and matched to the application allows rapid grease selection. The F'IS team also deals with special requirements such as rapidly biodegradable greases and greases for use in the food industry,

on the basis of ongoing innovation.

FAG Arcanol rolling bearing greases are also suitable for use in FAG automatic lubricators Motion Guard.



The software **Motion Guard SELECT MANAGER** Version 2.0 allows:

- selection of lubricators
- definition of dispensing times and relubrication quantities
- selection of suitable/preferred Arcanol greases
- management of a lubrication and maintenance plan

Use of the F'IS lubrication service can prevent the failure of rotating machine parts and increase productivity while reducing lubrication costs.



Services · Services relating to rolling bearings

Corrective maintenance

Balancing · Alignment

Corrective maintenance

Once a machine problem has been diagnosed, it should be eliminated as quickly as possible. Two of the most frequent problems – imbalance in pumps and fans as well as machine components incorrectly aligned to each other – can be corrected directly by F'IS.

Balancing

Imbalance is one of the main sources of malfunctions that lead to unexpected failure of machine elements. Correct balancing gives a decisive increase in the life of rotating machine parts. This increases the productivity and plant availability. The F'IS experts reduce the increased vibration that occurs due to contamination, wear, repairs etc. to a normal level. They detect and eliminate the causes of imbalances on machines at speeds of 40 to 10 000 rpm such as pumps, ventilators, compressors, turbines, motors etc. Irrespective of the sector, F'IS offers not only a detailed analysis of the reasons for the malfunction but also the removal of imbalances in any level of adjustment.

Alignment

Many of the standard pieces of equipment used in industrial facilities are composed of several components, for example an electric motor and pump/fan. After installation, repair or overhaul, the components of such machines must be aligned with each other. If this is carried out incorrectly or not at all, it results in high loads being placed on the bearings as well as increased energy demand and wear.

The methods and tools for machine alignment have changed in recent years: away from demanding and inaccurate methods using a dial

gauge and straight edge to laser alignment systems. These are highly accurate and effective. In addition to service products in this area (see page 55), F'IS also offers alignment of machinery as a service. Where necessary, the F'IS service technician will take the necessary laser alignment system to the customer and carry out alignment of the machine in accordance with the manufacturer's specifications. Successful completion of the work is then documented.

Please direct enquiries to:
info@fis-services.com



Services · Services relating to rolling bearings

Condition monitoring

Continuous measurement · Regular measurement

Condition monitoring

The malfunction-free and optimised operation of complex machinery and systems can only be achieved by means of condition-based maintenance.

The key method used by F'IS in condition-based maintenance is vibration diagnosis. This method makes it possible to detect incipient damage in machinery at a very early stage. The customer can thus take a proactive rather than a reactive approach. For example, damaged components can be replaced as part of planned downtime. Above all, vibration diagnosis helps to avoid unplanned downtime and expensive secondary damage, to increase productivity and improve availability.

Depending on the type of machine and its importance for the production process, different methods are used in condition monitoring: continuous monitoring (online) and regular monitoring (offline).

Continuous measurement (online)

In the case of production-critical machinery, permanent monitoring by means of vibration diagnosis is indispensable in many cases.

Access at any time to precise information on the condition of the machine offers the only effective protection against unplanned downtime and expensive production breakdowns as well as preventing secondary damage. For this reason, online monitoring generally pays for itself over a period of a few months. Depending on the area of application, F'IS offers a wide

range of solutions, including standalone solutions for smaller aggregates, medium-sized systems with up to 8 channels that can be extended on a modular basis and also complex monitoring systems with up to 2 048 sensors.

In addition to giving expert advice in selecting the right system, F'IS also implements plant monitoring. This includes not only hardware selection but also system configuration and, if necessary, its integration into existing systems. Depending on know-how, the customer can either carry out plant monitoring himself or enlist the F'IS monitoring service. The F'IS monitoring systems have e-service functionality, allowing external monitoring by F'IS experts under favourable terms.



Regular measurement (offline)

The failure of individual machines is not always critical for production. The failure of so-called “B” or “C” category plant items does not lead directly to downtimes and therefore does not induce expensive secondary damage.

For such machine parts, the more economical offline monitoring is generally recommended. In this case, costs and benefits are in an optimum ratio.

In offline monitoring, machinery is examined and assessed by vibration analysis at regular intervals, for example every 4 weeks. This regularity gives more in-depth knowledge of the normal condition of the machine, allowing deviations to be easily detected. When preparing the offline monitoring concept, the selection of measuring points and monitoring accessories as well as the definition of the measurement interval play a decisive role. It is not absolutely essential to have expertise on site. In the case of irregularities in measurements and trend analysis, F'IS offers the e-service. At the push of a button, all relevant data are exported from the database and sent by e-mail to the F'IS Diagnosis Centre, where it is subjected to expert analysis. The customer promptly receives easily understandable and authoritative diagnosis reports by e-mail.



Services · Services relating to rolling bearings

Condition monitoring

Regular measurement · Troubleshooting

Through close teamwork with the F'IS experts, the customer soon acquires excellent analytical know-how.

F'IS also offers support in data acquisition and carries out regular on-site measurements if the customer's internal personnel cannot be made available.

Troubleshooting

If malfunctions or other problems occur on a machine, a detailed defect analysis must be quickly carried out. This can be like detective work. Based on many years' experience in different sectors and applications, the F'IS diagnosis experts are well versed in such troubleshooting tasks. Their analysis incorporates various information, for example from visual observation, examination of the machine documentation and discussions with machine operators.

Problems or malfunctions in machine operation often become apparent through changes in vibration behaviour, unusual temperature patterns or similar phenomena. The F'IS experts therefore also carry out measurements on the machine. The measurement methods used will depend on the particular application. The F'IS experts are familiar with all measurement techniques, from vibration measurement to torque analysis or endoscopy. As a result, they can quickly identify malfunctions and prepare proposed solutions.

It is important to F'IS that customers are in a position to interpret the results of investigations correctly in order to introduce the correct

countermeasures. At completion of an investigation, F'IS therefore holds a handover meeting with all relevant employees of the customer to discuss not only the results of the investigation but also the recommended counteractive measures.

Vibration measurements

Detecting problems by using vibration analysis is the state of the art method in the field of troubleshooting. Like a doctor with a stethoscope, the vibration expert can assess the condition of the machine without the need for any dismantling. A large proportion of possible causes of damage can thus be detected and assessed with little work.



Modal analysis

Modal analysis is a particular form of vibration diagnosis. This method does not examine individual components of a machine but the machine as a whole. The aim is to determine the overall vibration behaviour of the machine. A model of the machine is created on the computer and a large number of measuring points are defined. The machine is then specifically excited using an impulse hammer. Based on parallel measurement of the excitation and resulting machine vibrations at the various measuring points, a vibration model of the machine can be determined by the computer and presented in three dimensions.

Modal analysis has a wide variety of possible applications:

- **Determination of natural frequencies or resonance frequencies**

Each machine has one or more natural frequencies that are determined by its design (mass and rigidity). If a machine is run in such a way that excitation (e.g. the speed of the motor) occurs in the region of a natural frequency, extreme vibration of the machine can occur. Based on the results of modal analysis, our experts can submit recommendations for design improvements to the machine.

- **Detection of a “soft point” of a machine**

If a high level of vibration occurs at initial operation or after a technical modification of a machine, this may be due to a “soft point”. This is defined as a rigidity problem, often caused by

Services · Services relating to rolling bearings

Condition monitoring

Troubleshooting

a poor quality connection between two machine parts (for example a screw connection). For analysis, the measurements are used to produce an animation showing the movements of the machine. Showing the movement of the individual machine parts in relation to each other quickly leads to identification of the “soft point” of the machine. A discussion can then be held to prepare proposals for improving the design of the machine.

Torque/force measurements

If damage accumulates at a particular point in the system, a design problem may be surmised. Overloading of shafts or bearing positions that were not taken into consideration in the design of the machine can be detected by means of torque or force measurements and taken into consideration in an improved structure of the machine. Depending on the application, temporary installations or fixed installations can be used. In particular, continuous torque measurement carried out directly on rotating shafts is highly demanding on a technical level: the measurement data must be transferred from the rotating shaft and the contact-free supply of energy must be provided. Implementing the long term installation of such telemetry systems under industrial conditions requires considerable experience, which the F'IS experts have gained over many years.

Endoscopy

If damage has been detected, for example, but the component cannot be replaced in the short term for production reasons, the precise extent of the damage can be determined using endoscopy. The interior of the machine is examined using digital optical endoscopes. The images are stored in the form of digital photographs or videos and are used as the basis of diagnosis by F'IS experts. Individual components such as rolling bearings or gear teeth can then be easily assessed. If the bearings inspected are Schaeffler KG products, the customer also has access to the knowledge of Schaeffler application engineers. They will prepare a detailed damage analysis and submit well-qualified proposals for improvement. This is an advantage that clearly demonstrates the benefits of obtaining products and services from a single source.

Thermography

Thermography is one of the most important non-destructive diagnostic techniques. Many technical problems manifest themselves in the form of heat generation, which can be detected with the aid of a high resolution infrared camera. The major advantage of thermography is the rapid, non-contact collection of temperature data. Simultaneous recording of a digital, optical image allows precise allocation of the temperature gradients to visible features on site.

There is a wide range of objects that can be examined by this method: it extends from assessment of electrical connections in switch cabinets, through rolling bearing arrangements in motors and fans, to thermal linings in cement works.

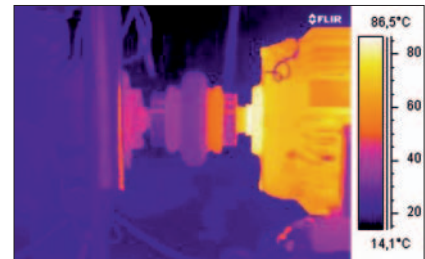

© FLIR Systems

Approval inspection of a new plant

The combination of different diagnostic techniques enables F'IS to carry out an assessment of a new plant regardless of the manufacturer. Frequently occurring installation errors such as defective alignment of motors and pumps/fans to each other or incorrect electrical connections in switch cabinets can thus be detected in the initial operation phase and their correction required by the plant manufacturer. If such defects remain undetected over the period of the warranty, their removal and the secondary damage may cause considerable costs and downtime. As part of the new plant approval inspection, F'IS checks the most common problems and records the actual status. Where necessary, corrective measures can then be required of the plant manufacturer or operator in good time.

Services · Services relating to rolling bearings

Condition monitoring

Technical consultancy

Technical consultancy

In addition to providing services, consultancy is one of the main activities of F'IS.

Companies that wish to change to the concept of condition-based maintenance are supported by F'IS with initial training, attendance during the introductory phase, expert backup and customised service contracts.

Furthermore, F'IS offers support in the introduction and adaptation of maintenance planning and control systems (CMMS). These systems help to improve transparency of the services and costs involved in maintenance (see page 88).

Introduction of condition-based maintenance

Many customers intend to convert their maintenance activities wholly or partly to a condition-based maintenance strategy in the coming years. Maintenance of machinery and plant will no longer be based on failures or times but on their assessed condition. The aim of the F'IS consultants is to find the perfect balance between the costs and benefits of condition assessment. Many years of experience in condition monitoring and maintenance planning give an optimum basis here, which allows recommendations on methods and products for condition monitoring to be made after a soundly-based analysis of the critical plant and machinery. In partnership with the customer, plans are prepared that generate recommended activities

for the maintenance personnel derived from the results of condition monitoring. Ultimately, it are these recommendations and not alarm messages that lead to targeted maintenance activities and thus to cost savings.



Service concepts for plant manufacturers and operators

Services are not volume products – the needs and requirements vary from customer to customer – so the service concept must be tailored as a result.

Due to the wide range of services F'IS can offer its customers, it is possible to customise the right package of training and services together with the activities carried out by the customer himself. The scope is enormous and depends on the prior knowledge and usable work capability of the customer as well as the requirements for quality of monitoring. Some selected examples should help to clarify this:

- **“Customer A has employees with experience in the field of condition monitoring”**

In such a case, it is sufficient to instruct the employees in handling the systems and accompany them while making the initial steps. Furthermore, F'IS acts as a team of experts that can be called in on difficult cases and support the customer in the analysis and formulation of activities.

- **“Customer B would like to build up its knowledge in the field of condition monitoring”**

The field of condition monitoring is a complex subject; building up knowledge will therefore take some time. For such cases, F'IS offers a 2 year programme, after which even customers without prior knowledge can themselves monitor the condition of their machinery. The support given by F'IS is progressively reduced in various steps and the customer's employees use their new knowledge directly in their daily work.

- **“Customer C wishes to completely outsource the area of condition monitoring”**

F'IS offers complete packages in which the entire service is provided by F'IS. This begins with the initial operation of systems and progresses through continuous monitoring to complete leasing of the hardware, so that no initial costs are incurred by the customer. Such monitoring packages are very attractive, for example to customers in the wind power industry.

Services · Services relating to rolling bearings Condition monitoring

Technical consultancy

- **“Customer D is a plant manufacturer and wishes to offer condition monitoring as a service itself”**

In this case, F'IS acts as a subcontractor of mostly portable monitoring systems, a trainer of the service employees of the plant manufacturer and as an expert team that can always be called upon to assist when matters arise that cannot be clearly assessed by the employees of the plant manufacturer. The plant manufacturer can thus offer its customers a highly qualified monitoring service without having to establish its own experts.

These four examples show how customised service concepts can vary. Based on individual customer requirements, F'IS prepares a concept to meet the needs and assists in its implementation.

Please direct enquiries about the services described to:
info@fis-services.com



Services · Maintenance management

Maintenance consultancy

Maintenance consultancy

Maintenance consultancy by F'IS helps to make costs more transparent and design maintenance more effective. Therefore it is based on classical consulting but with a strong technical focus.

Consulting starts with a comprehensive analysis of the relevant processes. On this base the F'IS team prepares customer-specific improvement concepts to integrate

individual solutions to an overall solution. F'IS offers support during the implementation phase and as part of a partnership in following project phases.

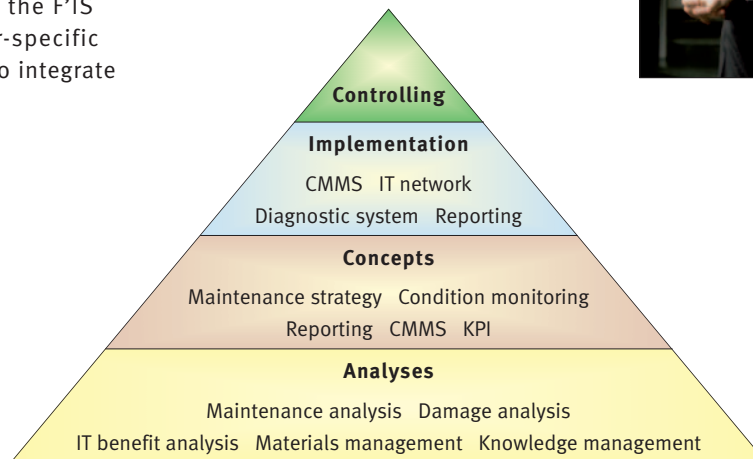

Phases in a consultancy process

Analyses

The F'IS team analyses the actual situation by carrying out workshops with employees and investigating the available documents. The analysis considers subjects including:

- business processes, costs, personnel structure, tasks/ responsibilities, machine utilisation
- commercial and production KPIs
- technical support for processes
- utilisation of IT and condition monitoring systems
- maintenance strategies
- knowledge management

- maintenance KPIs
- co-operation between departments

Based on their experience, the F'IS consultants can evaluate the information obtained and place it within an overall context. Anonymous data from other companies and sectors are also drawn upon for comparison. As requested by the customer, the results are presented at a management and/or plant level.

Services · Maintenance management

Maintenance consultancy

Concepts and implementation

The concepts are prepared by F'IS consultants together with the customer and are focused on the situation and vision of the customer. Each customer gets an individual solution. The concepts are implemented in partnership with the customer.



Maintenance strategy:

- ABC analysis of plant stock
- TCO (Total Cost of Ownership)
- LCC (Life Cycle Cost)
- TPM (Total Productive Maintenance)
- Condition-based maintenance (see page 84)

Implementation concept for a CMMS:

- Software selection
- Master data structures
- Strategy for recurring maintenance and inspection tasks
- Specification and implementation of interfaces
- Transfer of old data

IT network:

- Selection of software based on required attributes
- Development of a thorough data model
- Specification of interfaces
- Specification of the necessary hardware

Improvement of reporting system:

- Creation of KPIs
- Automatic reports
- Electronic reporting via the Internet
- Benchmarks with partner companies



Care of concepts

In order to keep the optimisation of costs and benefits achieved in the long term, regular assessments are carried out after the implementation phase. These assessments are made by the customer himself and the support of the F'IS consultants as a neutral partner. Maintenance controlling can be managed by an extended reporting system, KPIs and benchmarks. It is important to check permanently the maintenance controlling process itself with the focus on its expressiveness and efficiency.

Services · Maintenance management CMMS

CMMS

In the section of Computerized Maintenance Management Systems (CMMS), F'IS experts apply their profound technical knowledge to offer analysis of customer-specific requirements. This service is independent of the software system. Even by using a standard software, which is available on the market, F'IS can configure and optimise this software on the purpose of the customer.

The F'IS service covers both complete solutions in the form of CMMS implementation as well as individual modules for the following areas:

Systems integration

CMMS is incorporated in the IT environment of the company by the implementation of interfaces, for example to ERP (Enterprise Resource Planning) systems. This allows holistic assessment and data analyses in a complete system, so that redundant data administration and multiple data input can be avoided. Process operations are standardised and optimised.



The exchange of information across departments is improved.

Mobile solutions

The use of electronic checklists on a handheld PC enables the data collection during an inspection. The processing and feedback of failures can then take place with ongoing acquisition. The data determined and checked for consistency are transferred via a workshop PC to the CMMS database.

The mobile system avoids most of manual data input. Data quality and analysis potential are increased through the use of standardised coding.

Establishment/expansion of the reporting system

The integration of reports into the CMMS offers versatile possibilities for data analysis and representation. Typical applications in this field include evaluation and failure analyses with multi-stage reports, stock and master data lists as well as internal and external business paperwork. Reports can be generated quickly and easily. Quality of information is improved by electronic completion of forms. The use of standardised reports conforms to the requirements of certification.

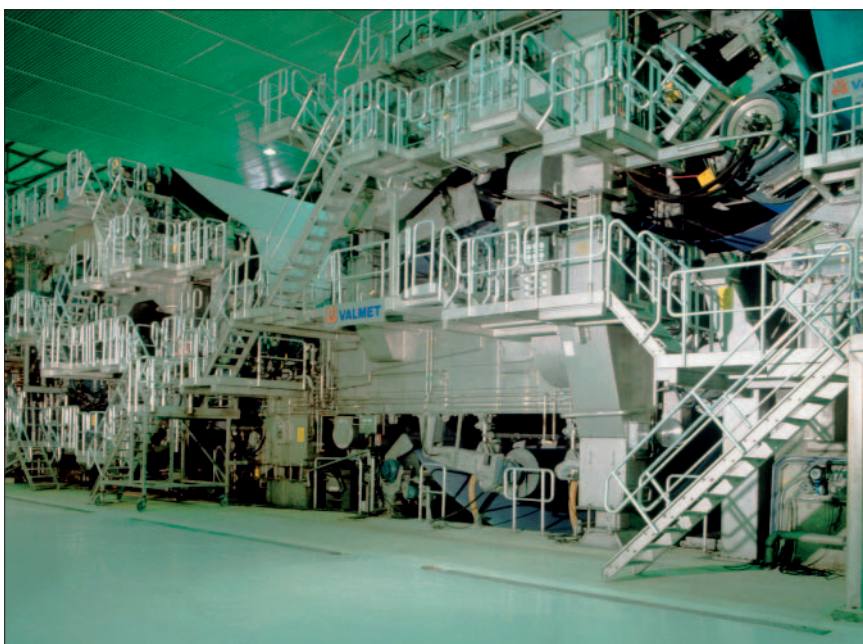

Services · Maintenance management CMMS

Further services for CMMS

- Release and database platform changeover
- CMMS modifications and expansion functions
- Data analysis and corrective data administration
- Implementation of automated processes
- Training of your personnel to user and administrator level

Please direct enquiries to:
info@fis-services.com

Training



Overview 92

Training descriptions 93

Mounting/Repair 93

Lubrication 95

Alignment 95

Condition Monitoring 96

Maintenance management 99

Training aids 100

Training · Overview

F'IS offers, in relation to the product and service range, both standard training and customer-specific training. The individual training units are based on a modular concept with the result that customers can compile their own customised

training course on the basis of these training components. After successfully attending the training, each attendee receives a certificate. The training courses are offered both at Schaeffler Group locations and also on site at our customers.

The current training offer including dates for the standard training courses can be found at www.fis-services.com in the section Training.

Overview of F'IS training courses		
Overview of F'IS training courses	Training format	
Training module	Standard	Individual
Mounting and repair		
Basic training: Rolling bearing technology	•	•
Product training: Mounting tools		•
Basic training: Spindle bearing technology	•	•
Rolling bearing maintenance for railway vehicle maintenance personnel (general)	•	•
Rolling bearing maintenance for TAROL bearings		•
Lubrication		
Product training: FAG lubrication systems Motion Guard		•
Product training: FAG Arcanol lubricants		•
Alignment		
Product training: FAG Top-Laser TRUMMY2, SMARTY2 and INLINE		•
Condition Monitoring		
Product training: FAG Detector III Basic	•	
Product training: FAG Detector III Balancing	•	
Product training: FAG Detector III Advanced	•	
Product training: FAG Administrator 4.0	•	
Product training: FAG DTECT X1 (with Administrator 4.0)	•	
Product training: FAG ProCheck (with Administrator 4.0)	•	
Product training: FAG VibroCheck: Installation (hardware)	•	
Product training: FAG VibroCheck: Application (software)	•	
Product training: FAG DTECT X1 (with Administrator 3.8)		•
Product training: FAG Detector II		•
Maintenance management		
User training for implemented CMMS		•
CMMS administrator training		•

More detailed information on the individual training courses can be found on the following pages.

Training · Training descriptions

Mounting/Repair

Mounting/Repair

Basic training: Rolling bearing technology

Training content: This training communicates basic knowledge on rolling bearings and their use. Our rolling bearing experts will explain types, characteristics and designations of rolling bearings. In the practically-based part of the training, correct mounting and dismounting will be communicated. Rolling bearing failures will be discussed, together with their symptoms and causes.

Target group: The course is aimed at head foremen, foremen and mounting personnel from maintenance shops and interested employees. No special knowledge is required.

Training objective: The participants will learn the correct and professional handling of rolling bearings and gain basic knowledge of mounting and dismounting.

Duration: 1–2 days

Product training: Mounting tools

Training content: This training focuses on various tools for the correct mounting and dismounting of rolling bearings. Particular emphasis is placed on the correct use of tools on a day-to-day basis. The content of customer-specific training is always agreed with the customer.

Target group: The course is aimed at head foremen, foremen and mounting personnel from maintenance shops and interested employees. No special knowledge is required.

Training objective: The participants will learn the correct handling of mounting and dismounting tools that they use day to day.

Duration: By agreement

Basic training: Spindle bearing technology

Training content: In this training, the participants will acquire basic knowledge of spindle bearings and their use. Our spindle bearing experts will explain the types, characteristics and designations of spindle bearings. In the practically-based part of the training, correct mounting and dismounting of spindle bearings will be communicated. Specific spindle bearing failures will be discussed.

Target group: The course is aimed at head foremen, foremen and mounting personnel from maintenance shops and interested employees. No special knowledge is required.

Training objective: The participants will gain basic knowledge of spindle bearings and their mounting, dismounting and maintenance.

Duration: 1 day



Training · Training descriptions

Mounting/Repair

Rolling bearing maintenance for railway vehicle maintenance personnel (general)

Training content: This training covers the maintenance of wheelset bearings based on cylindrical and tapered roller bearings. Rolling bearing experts from railway application engineering will communicate current knowledge on the bearings and their application. Experienced setting supervisors will pass on their knowledge concerning manual work for rolling bearing maintenance and show correct handling using selected demonstration items.

Target group: The course is aimed at head foremen, foremen and mounting personnel from railway vehicle maintenance workshops.

Training objective: The course participants will receive practical guidance on the maintenance of wheelset bearings based on simple cylindrical and tapered roller bearings.

Duration: 1–2,5 days

Rolling bearing maintenance for TAROL bearings

Training content: The subject of this training is the maintenance of TAROL wheelset bearings. These double row tapered roller bearing units are adjusted, greased and sealed on both sides. Rolling bearing experts from railway application engineering will communicate current knowledge on the bearings and their application. Experienced setting supervisors will pass on their knowledge concerning manual work for the maintenance of TAROL bearings and

show the particular aspects of this maintenance using selected demonstration items.

Target group: The course is aimed at head foremen, foremen and mounting personnel from railway vehicle maintenance workshops.

Training objective: The course will enable the participants to carry out maintenance of TAROL bearings independently.

Duration: 1 day
(by agreement only)



Training · Training descriptions

Lubrication · Alignment

Lubrication

Product training:
FAG lubrication systems
Motion Guard

Training content: This training covers the FAG lubrication systems “Motion Guard” in relation to functionality, possible applications, usage and handling. The focus is on the safe handling and boundary operating conditions of the FAG lubrication systems.

Target group: The course is aimed at head foremen, foremen and mounting personnel from maintenance shops and interested employees. No special knowledge is required.

Training objective: Following the course, the participants will be able to correctly select and use the various products in the lubrication system “Motion Guard” to ensure that unplanned machine downtime due to defective lubrication is avoided.

Duration: By agreement



Product training:
FAG Arcanol lubricants

Training content: In this training, the participants will acquire further knowledge of the FAG lubricant family “Arcanol” in relation to possible applications, usage and handling. It will be shown how selection of the correct lubricant can increase the performance capacity and life of rolling bearings.

Target group: The course is aimed at head foremen, foremen and mounting personnel from maintenance shops and interested employees. No special knowledge is required.

Training objective: Following the course, the participants will be able to select the correct grease for their particular application.

Duration: By agreement

Alignment

Product training: **FAG Top-Laser**
SMARTY2, TRUMMY2 and INLINE

Training content: This course communicates well-founded knowledge on the alignment of belt drives and shafts and the measurement of belt tension. The functionality, possible applications and handling of the measuring systems Top-Laser TRUMMY2, SMARTY2 and INLINE are explained. The focus is on the safe handling and boundary operating conditions of the measurement systems.

Target group: The course is aimed at head foremen, foremen and mounting personnel from maintenance shops and interested employees. No special knowledge is required.

Training objective: Following the course, the participants will be able to carry out the required alignment work using the measuring systems.

Duration: By agreement

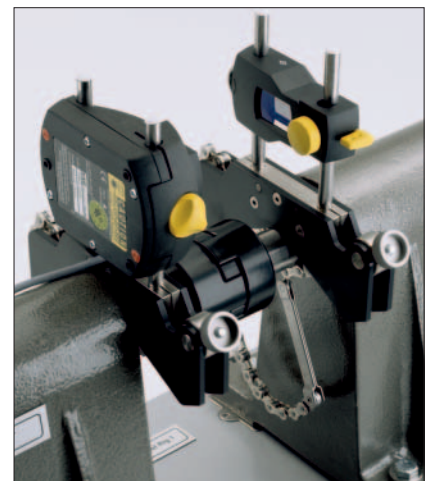

Training · Training descriptions

Condition Monitoring

Condition Monitoring

Product training:
FAG Detector III Basic

Training content: This training conveys basic knowledge both of vibration theory and vibration monitoring as well as the handling of the measuring system FAG Detector III. The course participants will receive an overview of the functionality, possible applications, configuration and handling of the measuring system.

Target group: The course is aimed at head foremen, foremen and mounting personnel from maintenance shops and interested employees. No special knowledge is required.

Training objective: The participants can subsequently detect simple machine defects by means of trend analyses and determine the cause on the basis of the time signal and spectrum.

Duration: 3 days



Product training:
FAG Detector III Balancing

Training content: The course covers in particular the subject of balancing using the FAG Detector III in theory and practice and is aimed at participants who have completed the course “FAG Detector III Basic” and now wish to learn about using the “Balancing Kit”. The participant will learn to use the device safely and independently carry out balancing operations with the FAG Detector III.

Target group: The course is aimed at participants who are already familiar with use of the Detector III. Participants must have previously attended the product training course “FAG Detector III Basic”.

Training objective: The participants will learn how to safely use the FAG Detector III during a balancing procedure.

Duration: 1 day

Product training:
FAG Detector III Advanced

Training content: Building on the training “FAG Detector III Basic”, this course goes into greater detail on the theory of vibration examination and monitoring covered in the aforementioned course. This course comprehensively covers special subjects such as the symptomatic form of individual machine defects. Aspects relating to the condition monitoring of individual machine parts will be discussed in detail in relation to defects and problems and reconstructed in some cases using practical exercises.

Target group: This course is aimed in particular at technicians and engineers working in maintenance as well as interested employees who have already attended the course “FAG Detector III Basic” or have at least one year’s experience in the use of measuring systems.

Training objective: After the training, the participant should be in a position to identify the symptomatic form of individual machine defects and determine their cause.

Duration: 2 days

Training · Training descriptions

Condition Monitoring

Product training: **FAG Administrator 4.0**

Training content: This training is concerned with the installation and individual modules of the software FAG Administrator 4.0. The focus is on the function of the individual modules and the use of the Data Viewer – a special analysis tool. The principles of communication technologies are also presented.

Target group: The course is aimed in particular at participants who have already attended the training units “FAG Detector III Basic/Advanced”. Alternatively, at least one year’s practical experience with an offline or online vibration measuring system is required.

Training objective: After the training, the participant can securely install the software and is familiar with the function of the individual modules.

Duration: 2 days

Product training: **FAG DTECT X1*** **(with Administrator 4.0)**

Training content: On the basis of the training units “FAG Detector III Basic/Advanced” and “FAG Administrator 4.0”, this course gives well-founded knowledge on the online measuring system “FAG DTECT X1” in relation to functionality, possible applications, usage and handling. In particular, the versatile possible configurations of the system are communicated intensively in practical usage.

Target group: The course is aimed in particular at technicians and engineers working in maintenance as well as interested employees. Participants must have previously attended the product training course “FAG Administrator 4.0”.

Training objective: Following the course, the participants will be able to identify machine defects and damage in detail based on trend analysis using the measuring system by remote diagnosis and online.

Duration: 2 days

* Also usable for FAG WiPro.



Product training: **FAG ProCheck** **(with Administrator 4.0)**

Training content: In this training, the participant will learn to apply the knowledge acquired in the training unit “FAG Administrator 4.0” to the online measuring system FAG ProCheck. The focus is on configuration and independent preparation, implementation and evaluation of a measurement process using examples.

Target group: The course is aimed in particular at technicians and engineers working in maintenance as well as interested employees. Participants must have previously attended the product training course “FAG Administrator 4.0”.

Training objective: Following attendance at this course, the participant should be in a position to configure the measuring system FAG ProCheck and independently prepare, implement and evaluate measurement processes.

Duration: 2 days

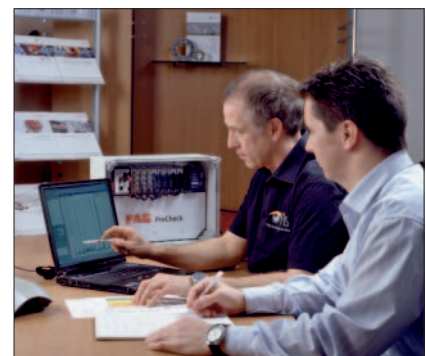

Training · Training descriptions

Condition Monitoring

Product training: FAG VibroCheck: Installation (hardware)*

Training content: The course communicates knowledge on the use of the VibroCheck (VC) hardware. The focus is on the interaction between the VC hardware and software (e.g. in hardware tests, sensor tests). The participant will learn to use terminal and circuit plans so he can independently undertake extension of the VC hardware.

Target group: This course is intended in particular for those persons who are responsible for the installation and maintenance of the measuring system “FAG VibroCheck”. Important preconditions are therefore PC and Windows knowledge as well as knowledge of electrical installation work.

Training objective: After the course, the participants should be in a position to independently maintain the measuring system in relation to hardware extension and troubleshooting as well as independently carry out hardware and software installations.

Duration: 2 days

Product training: FAG VibroCheck: Application (software)*

Training content: The knowledge acquired in the course “Detector III Advanced” on vibration analysis will be expanded and deepened on the measuring system VibroCheck. The focus will be on monitoring configuration of the measuring system “FAG VibroCheck” and evaluation of the recorded measurement data.

Target group: This course is aimed at persons who have already attended the training “Detector III Advanced” or have at least one year’s experience in the use of measuring systems and wish to add to this the specifics concerning the measuring system “FAG VibroCheck”.

Training objective: Following the course, the participants will be able to work correctly with the online measuring system VibroCheck. The focus of the training is on configuration. The course participant can subsequently visualise the machine using the VC software and analyse trend data, time signals and frequency spectra. He can assess and interpret parameter and expert alarms and handle the alarm logbook.

Duration: 2 days

* Please note that the product training courses FAG VibroCheck: Installation (hardware) and FAG VibroCheck: Application (software) are only bookable as a single package (total duration: 4 days).

Product training: FAG DTECT X1 (with Administrator 3.8)**

Training content: On the basis of the training unit “FAG Detector III Basic”, this course gives well-founded knowledge both on vibration diagnosis as well as the online measuring system “FAG DTECT X1” in relation to functionality, possible applications, usage and handling. In particular, the versatile possible configurations of the system are communicated intensively in practical usage. In addition, the principles of communication technology for teleservice are presented.

Target group: The course is aimed in particular at technicians and engineers working in maintenance as well as interested employees.

Training objective: Following the course, the participants will be able to identify machine defects and damage in detail based on frequency analysis using the measuring system by remote diagnosis and online.

Duration: 4 days
(by agreement only)

** Also usable for FAG WiPro.



Training · Training descriptions

Condition monitoring · Maintenance management

Product training: FAG Detector II

Training content: In this course, soundly-based knowledge will be communicated on the measuring system “FAG Detector II” in relation to functionality, possible applications, usage and handling.

Target group: The course is aimed in particular at technicians and engineers working in maintenance as well as interested employees. No special knowledge is required.

Training objective: The participant will then be able to identify machine defects and damage based on trend analysis using the measuring system.

Duration: By agreement

Maintenance management

User training for implemented CMMS

Training content: This course focuses on the established Computerized Maintenance Management System (CMMS) on the customers site. The content is defined in relation to the participants upon customer request.

Target group: The course is aimed at persons who have to operate the CMMS in their company. No special knowledge is required.

Training objective: The participants will learn how to use CMMS in a correct way and why it is important to enter the specified information into the system. They will also learn how to find certain information in the system, which is needed in the daily work.

Duration: By agreement

CMMS administrator training

Training content: This training covers the support and administration of the CMMS. The content can be defined in relation to the participants upon customer request and taken from the areas of database management, Internet technology, server support and authorisation concepts.

Target group: The course is aimed at system administrators and key users.

Training objective: The participants will learn about independent support and administration of a CMMS.

Duration: By agreement



Schaeffler Technical Training Centre, Hirschaid

Training · Training aids

Rolling bearing mounting cabinet and mounting sets: Basic course for vocational training

There is plenty of literature available on the the correct mounting of bearings. However, there is a general lack of parts on which apprentices can practise in as practical a sense as possible. The trainers from the Schaeffler training workshops have therefore compiled a basic course.

The aim of this rolling bearing course is to communicate knowledge on the selection of the correct bearing, correct mounting and dismounting and the maintenance of bearing positions. It is therefore divided into two parts. A theoretical part covers the basic knowledge of rolling bearing technology, while the practical part covers the basic skills involved in mounting and dismounting.

In the theoretical part, particular attention is paid to combining technical drawing, technical calculation and technical theory in one learning unit. The practical part uses exemplary simplified mating

parts (shafts, housings) on which the mounting and dismounting of common types of bearings can be practised with the aid of mechanical or hydraulic devices.

The content is composed of smaller learning stages and does not go beyond the degree of difficulty that is currently required in vocational training.

Building on this basic course, other assemblies such as gearboxes, pumps, spindles, road vehicle wheels etc. can be prepared for training.

Handbook 1 (Theoretical part)

- Technical theory
- Technical calculation
- Technical drawing

Handbook 2 (Practical part)

- Mounting of bearings with cylindrical bore
- Mounting of bearings with tapered bore
- Hydraulic method
- Exercises on shafts and housings

Technical data

Mounting cabinet:
Dimensions 1135×710×380 mm
Mass (including contents) 94 kg
Designed for 10 mounting exercises:
on 5 shafts
on 2 housings
on 3 shafts and housings
Smallest shaft diameter: 15 mm
Largest shaft diameter: 55 mm

Ordering designation
(mounting cabinet with contents and mounting bracket):
TRAINING-CABINET-MOD-1A-D

Further demonstration models for training are always available on request. Please contact: info@fis-services.com



Training · Training aids

Mounting set 1

Mounting set 1 is an **additional exercise** to the FAG mounting cabinet and facilitates the mounting of a self-aligning ball bearing in a housing.

Mounting set 1:

Plummer block housing

Suitable for the following exercises:

- Checking the bearing position
- Mounting of adapter sleeve and bearing
- Mounting as locating bearing
- Mounting as non-locating bearing
- Mounting as through shaft
- Mounting in housing closed on one side
- Dismounting of bearing and adapter sleeve

Ordering designation:

TRAINING-CABINET-MOD-1B



Mounting sets 2 und 3

The trainer can use the FAG mounting sets 2 and 3 – **individual exercises** from the FAG mounting cabinet - to demonstrate the mounting and dismounting of

Mounting set 2:

Shaft with housing

Suitable for the following exercises:

- Selection of fits
- Checking the bearing positions
- Mounting the bearing on the shaft
- Axial location of the bearing
- Mounting of the rotary shaft seal
- Assembly (locating bearing)
- Dismounting using extractor

Ordering designation:

TRAINING-CABINET-MOD-2



rolling bearings during teaching or have the apprentices carry these out. The shaft and housing parts can be clamped in a vice for mounting.

Mounting set 3:

Hydraulic mounting

Suitable for the following exercises:

- Mounting with the aid of pressure screws
- Mounting using a hydraulic nut
- Setting and checking the radial internal clearance
- Axial location using a locknut and tab washer
- Dismounting using an oil injector

Ordering designation:

TRAINING-CABINET-MOD-3



Training videos:

1 × 1 of rolling bearings

The film is particularly suitable for communicating initial basic knowledge on rolling bearings. It presents all types of bearings and highlights their characteristics features.

Ordering designation:

TRAINING-VIDEO-201-D

Mounting and dismounting of rolling bearings

The film explains the most important

rules of mounting in simple pictures and text. Cardinal mistakes are named in simple unambiguous terms. It is clearly shown, step by step, how various bearings are to be correctly mounted.

Ordering designation:

TRAINING-VIDEO-202-D

Hydraulic method for mounting and dismounting of large rolling bearings

The film shows, using simulated and real scenes, all the common methods and devices in hydraulic

mounting: pumps, hydraulic nuts, special extraction devices, adapter and extraction sleeves. It is also demonstrated what must be paid attention in the case of tapered or cylindrical shaft seats, and how the radial internal clearance or axial displacement should be correctly measured so that the mounted parts have the correct seating on the shaft.

Ordering designation:

TRAINING-VIDEO-203-D

Publications · Index of FAG products · Comparison of ordering designations



Publications	104
Index of FAG products	105
Comparison of ordering designations	109

Publications

Publications

WL 80 100	Mounting of rolling bearings
WL 80 102	Hydraulic method for mounting and dismounting of rolling bearings
WL 80 134	FAG video on the mounting and dismounting of rolling bearings
WL 80 135	FAG video on the hydraulic method for the mounting and dismounting of rolling bearings
WL 80 143	Competence in maintenance
WL 81 115	Lubrication of rolling bearings
WL 81 116	Arcanol Rolling Bearing Greases – For reliable, durable and cost-effective bearing arrangements
WL 81 122	FAG lubricator Motion Guard
WL 82 102	Rolling bearing damage

Technical Information/Product Information

TI WL 80-14	Mounting and dismounting of spherical roller bearings with tapered bore
TI WL 80-38	Mounting of self-aligning ball bearings using adapter sleeves
TPI WL 80-50	FAG pressure generators
TPI WL 80-54	FAG heating devices PowerTherm
TPI WL 80-55	FAG alignment tools
TPI WL 80-56	FAG tools for mechanical mounting and dismounting of rolling bearings
TPI WL 80-57	FAG hydraulic nuts
TPI WL 80-58	FAG tools for thermal dismounting
TPI WL 80-60	Condition monitoring using FAG products
TPI WL 80-62	FAG Detector II – the “mobile phone” among data collectors
TPI WL 80-64	FAG Detector III – the solution for monitoring and balancing
TPI WL 80-65	Monitoring of plant and machinery – Online System FAG DTECT X1
TI WL 80-66	FAG WiPro – Wind Turbine Protection
TPI WL 80-67	FAG VibroCheck online monitoring system for heavy industry
TPI WL 80-68	FAG Easy Check · FAG Easy Check Online
TPI WL 80-69	FAG ProCheck – state of the art machinery monitoring for maximum availability
TI WL 80-70	Measurement and dimensioning of tapered studs using the FAG taper gauge MGK9205
TPI WL 80-71	Training Courses: Rolling Bearings and Condition Monitoring – For Beginners and Advanced Students
TPI WL 80-72	Reconditioning and Repair of Rolling Bearings
FIS001	Smart Performance Program – Success through Collective Competence

CD-ROMs

CD Medias 4.2	Electronic INA/FAG rolling bearing catalogue
CD – MGSM 2.0	FAG Motion Guard Select Manager
CD – MM 1.1	FAG Mounting Manager

Index of FAG products

Index of FAG products		
Ordering designation	Product	Page
AGGREG-E700	Electrically driven hydraulic unit	27
AGGREG-P1000-1/P2500-2	Compressed air driven hydraulic unit	27
ARCA-GREASE-GUN	Arcanol grease gun	53
ARCA-GREASE-GUN.HOSE	Arcanol reinforced hose	53
ARCA-PUMP-25 (~180)	Grease metering device for 25 (180) kg grease container	53
ARCALUB-...	Lubricator COMPACT with grease charge, without activation screw	49
ARCALUB-CLEAR-...	Lubricator COMPACT CLEAR with grease charge, without activation screw	50
ARCALUB.ACTIVE-1M (~3M, ~6M, ~12M)	Activation screw for lubricator Motion Guard COMPACT	49
ARCALUB.ACTIVE-CLEAR-1M (~3M, ~6M)	Activation screw for lubricator Motion Guard COMPACT CLEAR	50
ARCALUB.ACTIVE-POLAR	Activation screw for lubricator Motion Guard COMPACT POLAR	50
ARCALUB.LC60-... (~LC120-..., ~LC250-...)	LC unit with 60 (120, 250) cm ³ of grease for lubricator CHAMPION	51
ARCALUB.LC120-...-KIT (~LC250-...-KIT)	Lubricator kit CHAMPION with LC unit 120 (250) cm ³	51
ARCALUB-C6-250-KIT (~500-KIT)	Multi-point lubrication system CONCEPT6 with LC unit 250 (500) cm ³	52
ARCALUB-C6-CONTROL-250-KIT (~500-KIT)	Multi-point lubrication system CONCEPT6, (machine controlled) with LC unit	52
ARCANOL-ANTICORROSIONOIL-400G	Spray can containing Arcanol anti-corrosion oil	42
ARCANOL-BIO2-...	Special grease for environmentally hazardous applications	47
ARCANOL-FOOD2-...	Special grease for applications with food contact	47
ARCANOL-LOAD150-...	Special grease for high loads, large speed range	46
ARCANOL-LOAD220-...	Special grease for high loads, large speed range	46
ARCANOL-LOAD400-...	Special grease for very high loads, moderate speeds	46
ARCANOL-LOAD1000-...	Special grease for very high loads, low speeds	46
ARCANOL-MULTITOP-...	Universal grease for high speeds, high loads, high temperatures	46
ARCANOL-MULTI2-...	Universal grease for bearings under normal loads (D ≤ 62 mm)	46
ARCANOL-MULTI3-...	Universal grease for bearings under normal loads (D > 62 mm)	46
ARCANOL-SPEED2,6-...	Special grease for very high speeds, low temperatures	47
ARCANOL-TEMP90-...	Special grease for low and high temperatures	47
ARCANOL-TEMP110-...	Special grease for low and high temperatures, high speeds	47
ARCANOL-TEMP120-...	Special grease for high temperatures, high loads	47
ARCANOL-TEMP200-...	Special grease for very high temperatures	47
ARCANOL-VIB3-...	Special grease for high loads, high temperatures, oscillating motion	47
ARCANOL-MOUNTINGPASTE-...	Arcanol mounting paste	42
BEARING-MATE250-450 (~450-650; ~650-850)	Transport and mounting tool for rolling bearings of outside diameter 250–450 mm (450–650 mm; 650–850 mm)	40

Index of FAG products

Index of FAG products		
Ordering designation	Product	Page
COIL...X...-LOW..	Coil for electric induction heating device with low voltage	35
COIL.TRAFO-...	Single phase dry transformer for heating device with low voltage	35
DETECT2-1MB-KIT	Detector II	65
DETECT3-KIT	Detector III	66
EASY-CHECK	Easy Check	67
EASY-CHECK-ONLINE	Easy Check Online	67
FEELER-GAUGE-100 (~300)	Feeler gauges, 100 (300) mm long, 13 (23) blade	36
FITTING-TOOL-ALU-10-50	Mounting tool set (aluminium) for rolling bearings of bore diameter 10–50 mm	8
FITTING-TOOL-STEEL-10-50	Mounting tool set (steel) for rolling bearings of bore diameter 10–50 mm	8
GLOVE1 (~2)	Heat-resistant (heat-resistant and oil-resistant) gloves	41
HEATER10	Induction heating device for workpieces up to 10 kg mass	32
HEATER20	Induction heating device for workpieces up to 20 kg mass	32
HEATER35	Induction heating device for workpieces up to 35 kg mass	32
HEATER150	Induction heating device for workpieces up to 150 kg mass	32
HEATER300	Induction heating device for workpieces up to 300 kg mass	33
HEATER600	Induction heating device for workpieces up to 600 kg mass	33
HEATER1200	Induction heating device for workpieces up to 1 200 kg mass	33
HEATER3000	Induction heating device for workpieces up to 3 000 kg mass	33
HEATER-PLATE	Heating plate (1 500 W)	31
HEATER-PLATE-370C	Heating plate (2 200 W)	31
HEATING-RING-...	Heating ring for inner ring of cylindrical roller bearing or needle roller bearing	34
HEATING-RING.PASTE-20ML	Heat conducting paste (20 ml disposable syringe)	34
HYDNUT...	Hydraulic nut with metric internal thread	19
HYDNUT...-HEAVY	Hydraulic nut, reinforced design with smooth bore	19
HYDNUT...-INCH	Hydraulic nut with inch size internal thread	19
HYDNUT.GAUGE-DISPLACE	Displacement gauge for HYDNUT	20
INJECT1600 (~2500)	Oil injector 1 600 bar (2 500 bar)	24
INJECT1600.VALVE (~2500.VALVE)	Valve nipple for oil injector 1 600 bar (2 500 bar)	24
INJECT1600-SET (~2500-SET)	Set comprising oil injector 1 600 bar (2 500 bar) and valve nipple	24
KLR...	Taper ring gauge	36

Index of FAG products

Index of FAG products		
Ordering designation	Product	Page
LASER-INLINE	Shaft alignment device	58
LASER-SMARTY2	Belt pulley alignment device	56
LASER-TRUMMY2	Belt tension measuring device	57
LASER.SHIM..X...	Shims for Top-Laser alignment devices	60
LOCKNUT-DOUBLEHOOK-KM..	Double hook wrench for locknut KM..	11
LOCKNUT-DOUBLEHOOK-KM...-KIT	Double hook wrench kit for locknut KM..	11
LOCKNUT-DOUBLEHOOK-KM...-SET	Double hook wrench set (for locknuts KM5–KM8 / KM9–KM13)	11
LOCKNUT-FACEPIN-...	Jointed face wrench for precision locknut LNP...	10
LOCKNUT-FLEXIHOOK-...	Jointed hook wrench for locknut KM.. or precision locknut ZM(A)..	10
LOCKNUT-FLEXIPIN-...	Jointed pin wrench for precision locknut AM..	10
LOCKNUT-HOOK-KM...	Hook wrench for locknut KM..	9
LOCKNUT-SOCKET-KM...	Socket wrench for locknut KM..	9
MGA31-...	Enveloping circle gauge for outer enveloping circle	39
MGI21-...	Enveloping circle gauge for inner enveloping circle	39
MGK132 (~133)	Taper gauge for \varnothing 90...510 mm (27...205 mm)	38
MGK9205-12.SET (~30.SET)	Taper gauge set for large studs, taper 1:12 (1:30)	37
PULLER...	Mechanical extractor for small bearings	12
PULLER-HYD...	Hydraulic extractor	15
PULLER-INTERNAL10/100-SET	Internal extractor set (for bearings of bore diameter 10 to 100 mm)	14
PULLER-TRISECTION-...	Three-section extraction plate for hydraulic and mechanical extractors	17
PUMP1000-...L (~1600-...L, ~2500-...L)	Hand pump and accessories	25
PUMP2500-0,2L-KIT	High pressure pump set (2 500 bar)	26
PUMP4000-0,2L	High pressure pump (4 000 bar) and accessories	26
PUMP.ADAPTER-A-...(~B-...)	Pressure device accessory, adapter	28
PUMP.HOLDER-2 (~3)	Pump holder without (with) manometer connector	29
PUMP....MANO-G1/2	Manometer	29
PUMP....MANO-DIGI	Digital manometer	29
PUMP.NIPPLE-A-...(~B-...)	Pressure device accessory, reduction nipple	28
PUMP.PIPE-...	Pressure device accessory, high pressure hose	30

Index of FAG products

Index of FAG products		
Ordering designation	Product	Page
PUMP.SLEEVE-CONNECTOR-...	Pressure device accessory, sleeve connector for hand pumps	30
SNAP-GAUGE-.../...	Snap gauge	38
SNAP-GAUGE.MASTER...	Master disc for snap gauge	38
SOUND-CHECK	Polyscope sonar device	64
TACHOMETER	Digital hand tachometer	63
TEMP-CHECK-CONTACT	Temperature measuring device, contact type	62
TEMP-CHECK-PLUS	Infrared temperature measuring device, contact-free	62
TOOL-RAILWAY-AGGREGATE	Mobile hydraulic unit for batch mounting of TAROL bearings	27
TRAINING-CABINET-MOD-1A-D (~E, ~F, ~NL)	Mounting cabinet with contents and mounting bracket for basic course in German (English, French, Dutch)	100
TRAINING-CABINET-MOD-1B (~2, ~3)	Training case with rolling bearing, mounting tool, ...	101
TRAINING-VIDEO-201-D (E)	1×1 of rolling bearings in German (English)	101
TRAINING-VIDEO-202-D (E)	Mounting and dismounting of rolling bearings in German (English)	101
TRAINING-VIDEO-203-D (E)	Hydraulic method for mounting and dismounting in German (English)	101

Comparison of ordering designations

Ordering designation for Europe	Ordering designation for countries outside Europe
AGGREG-E700 AGGREG-P1000-1/P2500-2	AGGREGATE.E700 AGGREGATE.P1000/2500
ARCA-GREASE-GUN ARCA-GREASE-GUN.HOSE	ARCA.GREASE-GUN ARCA.GREASE-GUN.HOSE
ARCA-PUMP-25 (~180)	ARCA.PUMP.25 (~180)
ARCALUB-... ARCALUB-CLEAR-...	ARCA.LUB. ... ARCA.LUB.CLEAR
ARCALUB.ACTIVE-1M (~3M, ~6M, ~12M) ARCALUB.ACTIVE-CLEAR-1M (~3M, ~6M) ARCALUB.ACTIVE-POLAR	ARCA.LUB.ACTIVE.1M (~3M, ~6M, ~12M) ARCA.LUB.ACTIVE.CLEAR.1M (~3M, ~6M) ARCA.LUB.ACTIVE.POLAR
ARCALUB.LC60-... (~LC120-..., ~LC250-...) ARCALUB.LC120-...-KIT (~LC250-...-KIT)	ARCA.LUB.LC60 (~LC120, ~LC250) ARCA.LUB.LC120.SET (~LC250.SET)
ARCALUB-C6-250-KIT (~500-KIT) ARCALUB-C6-CONTROL-250-KIT (~500-KIT)	ARCA.LUB.C6-250.KIT (~500.KIT) ARCA.LUB.C6-CONTROL-250.KIT (~500.KIT)
ARCANOL-ANTICORROSIONOIL-400G	ARCA.ANTICORROSIONOIL.400G
ARCANOL-BIO2-... ARCANOL-FOOD2-... ARCANOL-LOAD150-... ARCANOL-LOAD220-... ARCANOL-LOAD400-... ARCANOL-LOAD1000-... ARCANOL-MULTITOP-... ARCANOL-MULTI2-... ARCANOL-MULTI3-... ARCANOL-SPEED2,6-... ARCANOL-TEMP90-... ARCANOL-TEMP110-... ARCANOL-TEMP120-... ARCANOL-TEMP200-... ARCANOL-VIB3-...	ARCA.GREASE.BIO2... ARCA.GREASE.FOOD2... ARCA.GREASE.LOAD150... ARCA.GREASE.LOAD220... ARCA.GREASE.LOAD400... ARCA.GREASE.LOAD1000... ARCA.GREASE.MULTITOP... ARCA.GREASE.MULTI2... ARCA.GREASE.MULTI3... ARCA.GREASE.SPEED2,6... ARCA.GREASE.TEMP90... ARCA.GREASE.TEMP110... ARCA.GREASE.TEMP120... ARCA.GREASE.TEMP200... ARCA.GREASE.VIB3...
ARCANOL-MOUNTINGPASTE-...	ARCA.MOUNTINGPASTE...
BEARING-MATE250-450 (~450-650; ~650-850)	BEARING.MATE250-450 (~450-650; ~650-850)

Comparison of ordering designations

Comparison of ordering designations	
Ordering designation for Europe	Ordering designation for countries outside Europe
COIL...X...-LOW.. COIL.TRAFO-...	COIL.../...LOW.. COIL.TRANSFORMER...
DETECT2-1MB-KIT DETECT3-KIT	FIS.DETECTORII.SET.1MB FIS.DETECTORIII.KIT
EASY-CHECK EASY-CHECK-ONLINE	FIS.EASYCHECK.V1 FIS.EASYCHECK.ONLINE.SET
FEELER-GAUGE-100 (~300)	FEELER.GAUGE100 (~300)
FITTING-TOOL-ALU-10-50 FITTING-TOOL-STEEL-10-50	FITTING.TOOL.ALU.SET10-50 FITTING.TOOL.STEEL.SET10-50
GLOVE1 (~2)	HANDSCHUH1 (~2)
HEATER10 HEATER20 HEATER35 HEATER150 HEATER300 HEATER600 HEATER1200 HEATER3000	HEATER10 HEATER20 HEATER35 HEATER150 HEATER300 HEATER600 HEATER1200 HEATER3000
HEATER-PLATE HEATER-PLATE-370C	HEATER.PLATE HEATER.PLATE.370C
HEATING-RING-... HEATING-RING.PASTE-20ML	HEATING.RING... HEATING.RING.PASTE.20ML
HYDNUT... HYDNUT...-HEAVY HYDNUT...-INCH HYDNUT.GAUGE-DISPLACE	HYD.NUT... HYD.NUT...HEAVY HYD.NUT...INCH HYD.NUT.DISPLACE.GAUGE
INJECT1600 (~2500) INJECT1600.VALVE (~2500.VALVE) INJECT1600-SET (~2500-SET)	OILINJECTOR1600 (~2500) OILINJECTOR...VALVE OILINJECTOR....SET
KLR...	KLR...

Comparison of ordering designations

Comparison of ordering designations	
Ordering designation for Europe	Ordering designation for countries outside Europe
LASER-INLINE	LASER.INLINE
LASER-SMARTY2	LASER.SMARTY2
LASER-TRUMMY2	LASER.TRUMMY2
LASER.SHIM..X...	LASER.SHIMS...
LOCKNUT-DOUBLEHOOK-KM..	LOCKNUT.DOUBLEHOOK.KM...
LOCKNUT-DOUBLEHOOK-KM...-KIT	LOCKNUT.DOUBLEHOOK.KM...KIT
LOCKNUT-DOUBLEHOOK-KM...-...-SET	LOCKNUT.DOUBLEHOOK.KM...SET
LOCKNUT-FACEPIN-...	LOCKNUT.FACE-PIN...
LOCKNUT-FLEXIHOOK-...	LOCKNUT.FLEXI-HOOK...
LOCKNUT-FLEXIPIN-...	LOCKNUT.FLEXI-PIN...
LOCKNUT-HOOK-KM...	LOCKNUT.HOOK.KM...
LOCKNUT-SOCKET-KM...	LOCKNUT.SOCKET.KM...
MGA31-...	MGA31
MGI21-...	MGI21
MGK132 (~133)	MGK132 (~133)
MGK9205-12.SET (~30.SET)	MGK9205.12.SET (~30.SET)
PULLER...	ABZIEHER...
PULLER-HYD...	PULLER.HYD...
PULLER-INTERNAL10/100-SET	PULLER.INTERNAL.SET10-100
PULLER-TRISECTION-...	PULLER.TRISECTION...
PUMP1000-...L (~1600-...L, ~2500-...L)	PUMP1000...L (~1600...L, ~2500...L)
PUMP2500-0,2L-KIT	PUMP2500.0,2L.SET
PUMP4000-0,2L	PUMP4000.0,2L
PUMP.ADAPTER-A-...(~B-...)	PUMP.ADAPTER.A....(~B....)
PUMP.HOLDER-2 (~3)	PUMP.HOLDER.2 (~3)
PUMP....MANO-G1/2	PUMP....MANO.G1/2
PUMP....MANO-DIGI	PUMP....MANO.DIGI
PUMP.NIPPLE-A-...(~B-...)	PUMP.NIPPLE.A....(~B....)
PUMP.PIPE-...	PUMP.PIPE....

Comparison of ordering designations

Comparison of ordering designations	
Ordering designation for Europe	Ordering designation for countries outside Europe
PUMP.SLEEVE-CONNECTOR-...	PUMP.SLEEVE.CONNECTOR....
SNAP-GAUGE-.../... SNAP-GAUGE.MASTER...	SNAP.GAUGE...-... SNAP.GAUGE.MASTER.DISK
SOUND-CHECK	SOUND.CHECK
TACHOMETER	TACHOMETER
TEMP-CHECK-CONTACT	TEMP.MG
TEMP-CHECK-PLUS	TEMP.CHECK.PLUS
TOOL-RAILWAY-AGGREGATE	TAROL.MOUNTING.AGGREGATE
TRAINING-CABINET-MOD-1A-D (~E, ~F, ~NL) TRAINING-CABINET-MOD-1B (~2, ~3)	MOUNTING.CABINET.D (~E, ~F, ~NL) MOUNTING.CABINET.SET3 (~SET1, ~SET2)
TRAINING-VIDEO-201-D (E)	VIDEOFILM201D (E)
TRAINING-VIDEO-202-D (E)	VIDEOFILM202D (E)
TRAINING-VIDEO-203-D (E)	VIDEOFILM203D (E)

Schaeffler KG

Postfach 1260
97419 Schweinfurt (Germany)

Georg-Schäfer-Strasse 30
97421 Schweinfurt (Germany)

Phone +49 2407 9149-66

Fax +49 2407 9149-59

E-Mail info@fis-services.com

Internet www.fis-services.com

Every care has been taken to ensure the correctness of the information contained in this publication but no liability can be accepted for any errors or omissions. We reserve the right to make technical changes.

© Schaeffler KG · 2008, March

This publication or parts thereof may not be reproduced without our permission.

WL 80 250/3 EA