

Precise and cost-effective speed measurement in an extremely limited space:

FAG Deep Groove Ball Bearings with an Integrated Sensor

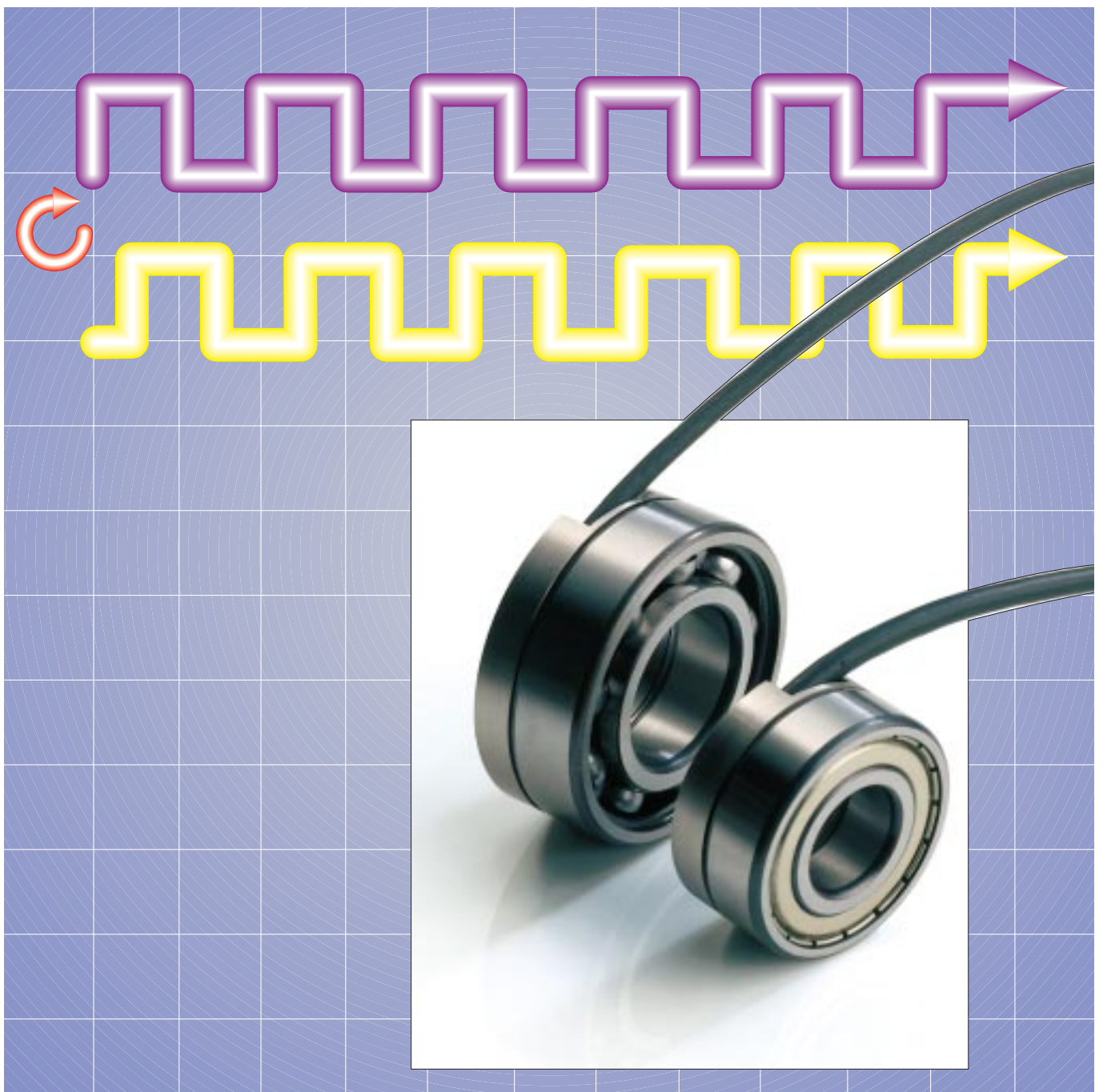

Applications · Advantages · Standard deep groove ball bearings with an integrated sensor

Application of sensor bearings

FAG deep groove ball bearings with an integrated sensor support rotating shafts, and in addition measure relative motions between the two bearing rings. The sensors record speed and sense of rotation. From these data the angular acceleration and number of revolutions can be derived. This information is increasingly needed in control engineering in order to monitor plants electronically and run them automatically.

Typical applications for rolling bearings with an integrated sensor include

- electric machines, especially frequency-controlled three-phase asynchronous motors
- transmissions, e.g. in machine tools, transmission motors
- materials handling equipment, e.g. elevators, escalators, belt conveyors, fork lift truck drives
- textile and packing machinery

Advantages of FAG sensor bearings

FAG deep groove ball bearings with an integrated sensor offer several advantages over solutions involving separate incremental encoders and other solutions:

- **Low cost**
Sensor bearings cost up to 50% less than solutions with incremental encoders
- **Little space required**
Bores and O.D.s are the same as those of standard deep groove ball bearings, only the overall width is greater by 8 mm; space-saving cable outlet in circumferential direction and strain relief
- **Simple mounting**
Sensor bearings are ready-to-mount units, no adjustment required; integrated anti-rotation system
- **Maintenance-free bearings**
Standard deep groove ball bearings with a shield or seal on one side, gap-type seal on the other side, for-life lubrication

- **Can be used as locating bearings**
Sturdy sensor housing allows axial loads
- **High measuring accuracy**
High pulse frequency and low dividing error
- **Good electromagnetic compatibility (EMC)**
Screened cable
- **Short circuit and polarity protection**

Sensor bearings - standard deep groove ball bearings with an integrated speed sensor

FAG sensor bearings have - except for the overall width - the main dimensions and the internal design of standard deep groove ball bearings of dimensional series 62. The abutment dimensions defined in DIN 5418 apply for the sensor bearings as well.

The cage is made of pressed steel.

Bearings with a normal radial clearance (clearance group CN) have no suffix identifying the clearance. On request, bearings with a smaller radial clearance (suffix C2) and with a larger radial clearance (suffixes C3, C4) than normal are also available.

The bearing is fitted on one side either with a shield (suffix ZR) or a seal (suffix RSR). Bearings with shields or seals are lubricated for life with standard grease, i.e. they require no maintenance.

Sensor bearings without sealing are also available.

The performance data - load ratings and high-speed suitability - for the designs 2ZR or 2RSR or open deep groove ball bearings of the same dimensions are as indicated in our catalogue WL 41 520 „FAG Rolling Bearings“.

The speed sensor unit is attached to the side opposite the seal, fig. 1. The sensor housing is attached in the sealing recess of the outer ring. The sturdy housing design allows axial loads. The labyrinth seal between sensor housing and pulse generator ring protects the bearing from contamination and retains the grease within the bearing.

Standard deep groove ball bearings with an integrated sensor · Sensor housing

The shielded connecting cable is attached in circumferential direction to the sensor housing and relieved of strain. The cable is very robust and requires little space, and no direct through-hole leading to the sensor bearing is needed.

Sensor housing with magnet and Hall-IC

Only one Hall sensor is required to measure just the speed. By using two Hall sensors, the FAG sensor bearings can record the sense of rotation as well. Depending on the sense of rotation, one of the 90 el° phase-shifted signals leads. In addition, the second sensor can be used

to increase the number of pulses per revolution. The external evaluation of the pulse flanks makes $4 \times 64 = 256$ pulses possible.

A magnetic field is generated by means of a permanent magnet positioned on top of the Hall-IC. The Hall-IC incorporates, apart from the Hall generator, also the signal amplifier and the signal converter. The analogue sinusoidal signal generated by the Hall generator is amplified, and converted into a square wave signal by a Schmitt-trigger, fig. 2. The signal is emitted through an output stage with actively driving transistors. A voltage of 5 to 24 V is required to operate the sensor. Speeds as low as nearly 0 revolutions per minute can be recorded.

1: The FAG speed sensor bearing is a standard deep groove ball bearing with an integrated speed sensor.

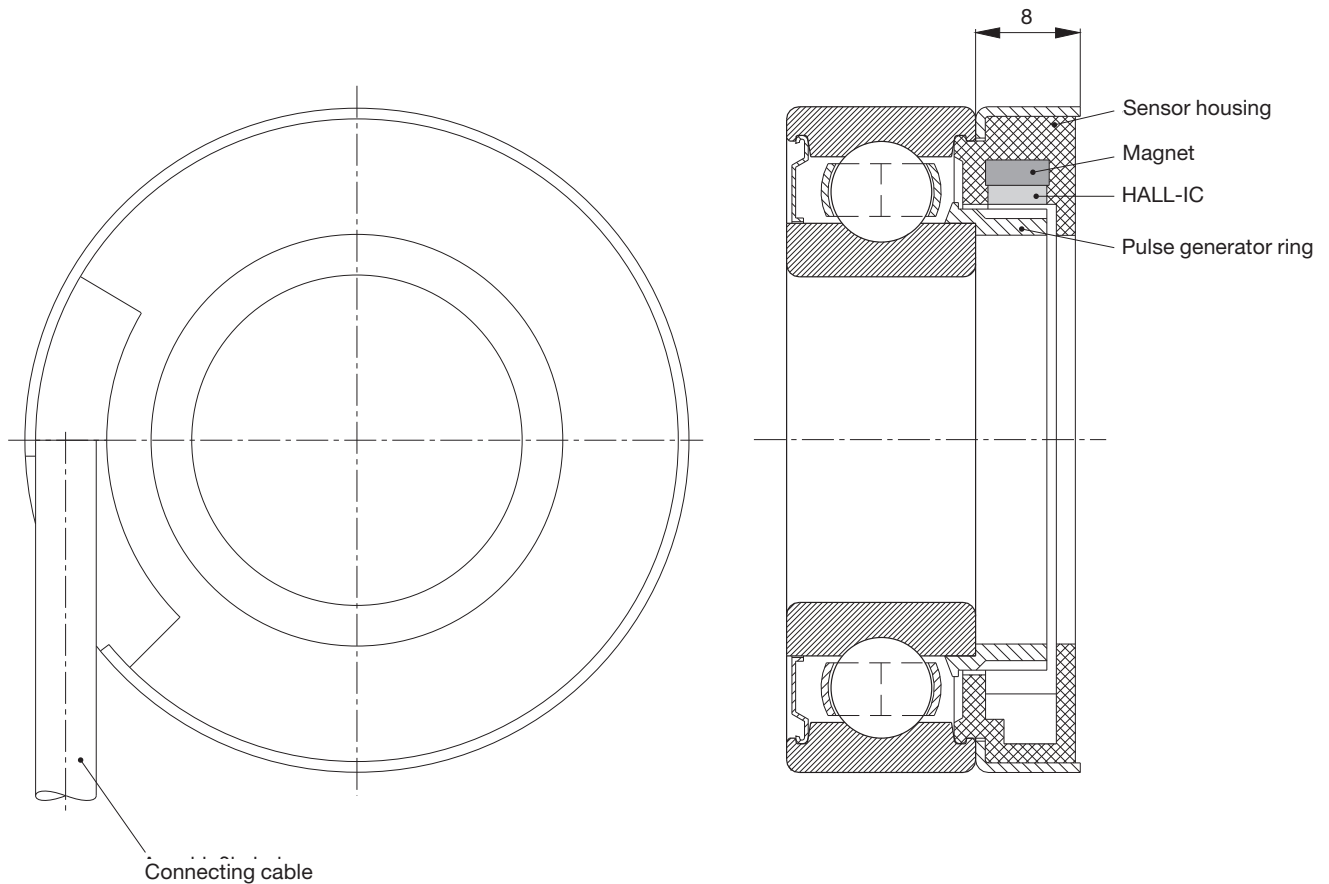

Pulse generator ring · Action · Mounting

Pulse generator ring

The pulse generator ring is made of a ferromagnetic sintered material and is mounted on the inner ring. In order to achieve a better separation of

2: Output signals of the speed sensor bearing

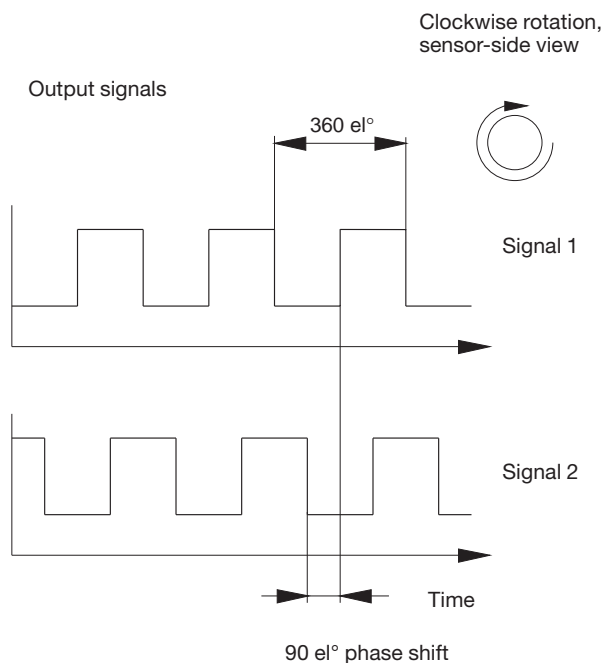

bearing inner space and sensor, the ring is provided with a flinger edge. The number of teeth on the pulse generator ring, and consequently the number of pulses per revolution, depend on the bearing size:

- 48 for bore diameters of up to 20 mm,
- 64 for bore diameters of 25, 30 and 35 mm,
- 80 for bore diameters from 40 mm on.

Action of the FAG speed sensor bearing:

The magnetic flux generated by the permanent magnet goes through the Hall sensor, then through a tooth on the pulse generator ring and then, outside the Hall sensor, back into the permanent magnet. As the pulse generator ring rotates, every time a tooth goes under the sensor, the magnetic flow density increases; every time a tooth gap is below the sensor, the flow generated by the permanent magnet is almost interrupted. Every time the magnetic field changes, the Hall-IC is triggered into action. The speed of the bearing is the quotient of the pulse frequency and the number of teeth on the pulse generator ring. The maximum switching frequency is limited to 20 kHz by the Hall sensor itself. The output signal is transmitted, via the connecting cable, to an electronic evaluation module - in the case of a three-phase asynchronous motor, usually to a frequency converter.

Mounting

Sensor bearings can be used where

- rotating shaft and circumferential load acting on the inner ring
 - stationary outer ring
- are involved.

Usually, the outer ring is stationary.

It may, however, be caused to rotate, too, under the influence of additional, dynamic forces (vibrations).

The sensor housing is mobile relative to the bearing outer ring and can be form-locked by means of adjacent parts (e.g. the motor's bearing shield). In this way, damage to the outgoing cable is prevented.

Technical data of the sensor unit

Output signals

- 2 square wave signals
- phase shift 90 ± 40 el°
- open-collector circuit with short-circuit fuse (up to 24V), fig. 3
- max. output current per signal: 40 mA
- pulses per revolution: 48 (design 6204), 64 (designs 6205, 6206) or 80 (designs 6208, 6209, 6210)
- dividing error $\pm 1\%$
- duty factor 1:1 $\pm 25\%$

Supply

- voltage: 5 V ... 24 V
- current consumption: max. 15 mA at $I_{out} = 40$ mA
- polarity protection up to max. 40 V and max. 60 s

Electromagnetic compatibility

- burst on control circuits: IEC 801-4, degree of sharpness 4
- ESD on housing components: IEC 801-2, degree of sharpness 2

Accelerations

- shock: max. 50 g over 6 ms (DIN IEC 68-2-27)
- vibration: max. 10 g between 55 and 2000 cps (DIN IEC 68-2-6)

Temperature range

- constantly: -30 °C ... $+120$ °C
- briefly: $+150$ °C

Power supply

- 0.46 m cable, outlet in circumferential direction
- 4 conductors + shield
- strain-relieved cable
- plug according to customers' requirements

3: Output circuit

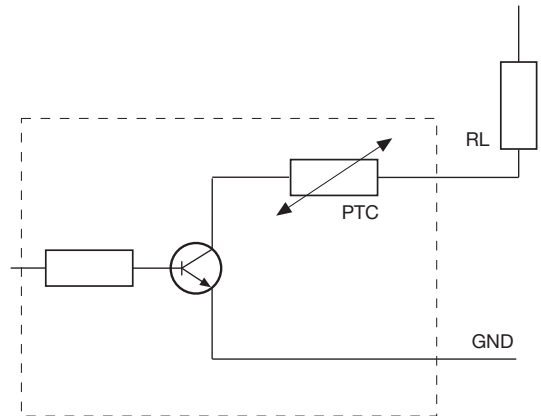

Programme

The FAG speed sensor bearings are based on deep groove ball bearings of series 62, beginning with bore reference number 04. Please contact us about the availability of specific bearing sizes.

Structure of order designation:

Example:

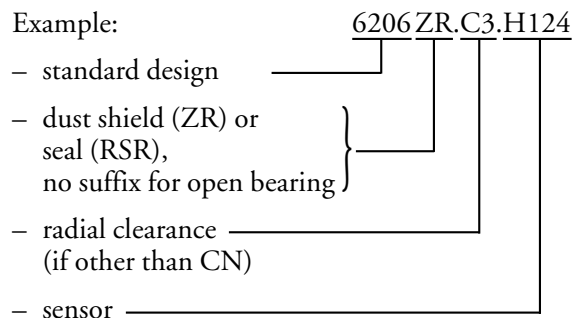

Information on other bearing sizes and special designs will be provided upon inquiry.

FAG OEM und Handel AG

A company of the FAG Kugelfischer Group

Postfach 12 60 · D-97419 Schweinfurt

Telephone (0 97 21) 91 30 09 · Telefax (0 97 21) 91 35 73

Telex 67345-0fag d · <http://www.fag.de>

FAG Deep Groove Ball Bearings with an Integrated Sensor

Every care has been taken to ensure the correctness of the information contained in this publication but no liability can be accepted for any errors or omissions.

We reserve the right to make changes in the interest of technical progress.

© by FAG 1998

TI No. WL 43-1206 E/96/12/98