

Roller Bearing Family of Products

ROLLER BEARINGS

BROWNING offers a broad and complete line of mounted roller bearing products to satisfy a large variety of rugged, industrial applications.

Browning roller bearings are completely assembled, adjusted and lubricated at the factory ready for use. Great for bulk material handling applications that require rugged quality bearings with reliable sealing. Installation is simple and instructions are included with each unit. Most Browning roller bearings can be dropped right in to replace competitive units.

Call your Browning distributor today...the power transmission specialist. Ask about Browning bearing engineered solutions and technical support services that are available and about information for other world class Browning and EPT products.

ROLLING ELEMENTS

Browning manufactures two types of roller bearings. High capacity double row tapered roller bearings are capable of combined radial and thrust loads within the bearing capacity. General purpose, double row spherical roller bearings are designed to accommodate increased rotational speeds and dynamic alignment.

LOCKING

Browning offers three types of shaft locking devices. Single set screw locking and dual set screw locking have one or two rugged lock collars to reduce inner race distortion. Browning also offers eccentric locking.

HOUSINGS

Roller bearing housings are segmented by style and available as pillow blocks, three and four bolt flanges, flange cartridges, and take-up units. General purpose cast iron housings are offered as well as high strength ductile units. 900, E920, 1000, and 1100 series are solid one piece units. 950, 970, 22200 and 22500 series have split housings for quick replacement and fast mounting.

EXPANSION UNITS

For applications with shaft expansion due to temperature differentials, 950, 970, 1000, 1100, 22200 and 22500 series roller bearings are all offered with an expansion design to accommodate shaft growth.

ROLLER BEARING CONTENTS

TAPERED ROLLER BEARINGS

900 Series Eccentric Lock	104
E920 Series Set screw Lock	110
950 Series Eccentric Lock	118
970 Series Set screw Lock	122

SPHERICAL ROLLER BEARINGS

1000 Series Set screw Lock	128
1100 Series Set screw Lock	136
22500 Series Adapter Mounted Bearing Units	140
Cast Iron Pillow Blocks	142
Cast Steel Pillow Blocks	144
22200 Series Cylindrical Bore Mounted Bearing Units	
Cast Iron Pillow Blocks	145
Cast Steel Pillow Blocks	146
22500/22200 Accessories	
22200 Adapter Bearings	147
22500 Adapter Assemblies	148
22200 Cylindrical Bore Bearings	149
22200 Cylindrical Bore Assemblies	149
Tactonite Seals & End Covers	151
Heavy Duty Frames	153

BALL & ROLLER BEARING INTERCHANGE TABLES	166
---	------------

Tapered Roller Bearings

PB900

Dimensionally Interchangeable with most Type E's

Tapered Roller Bearings Allow for Combination Radial and Thrust Loads

Eccentric Lock Collar

Centrap® Labyrinth Seal

One Piece Ductile Iron Housing

Elongated Bolt Holes to Facilitate Mounting

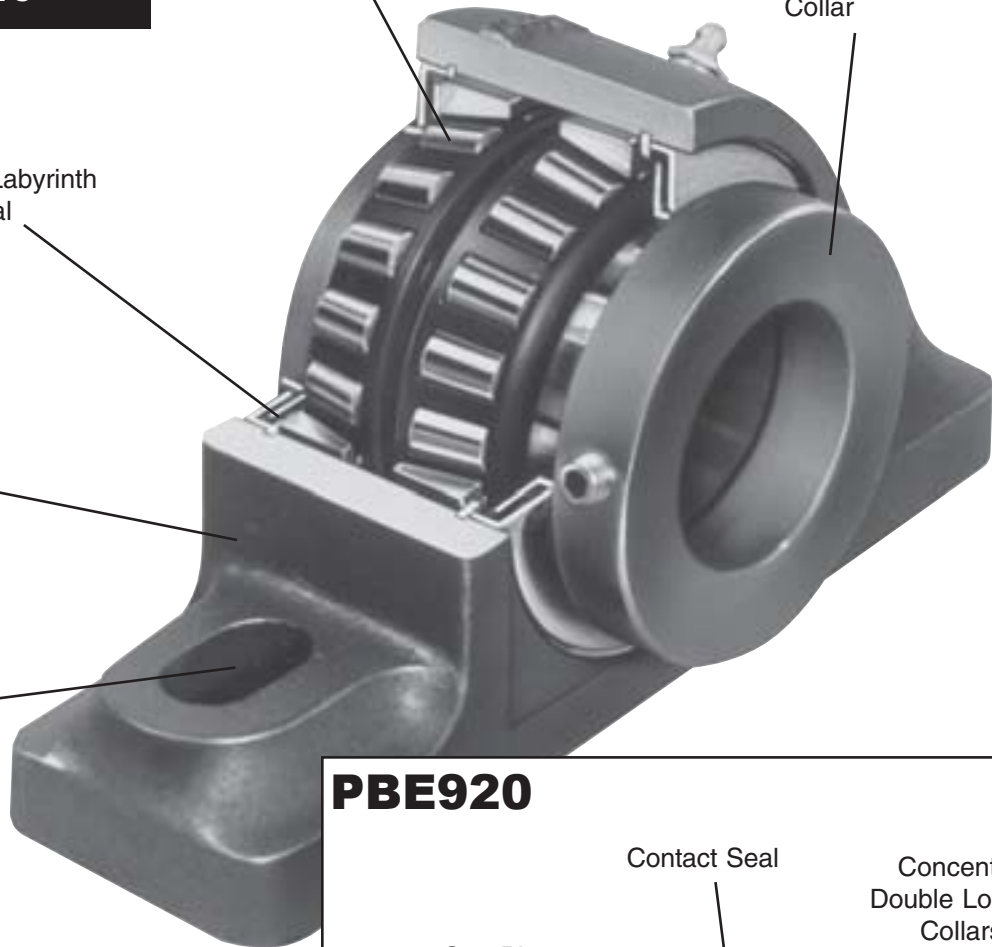

PBE920

Contact Seal

Concentric Double Locking Collars

One Piece Cast Iron Housing



Note: Other features are like the 900 series.

BROWNING TAPERED ROLLER BEARINGS 900/E920 SERIES FEATURES/BENEFITS

LOCKING

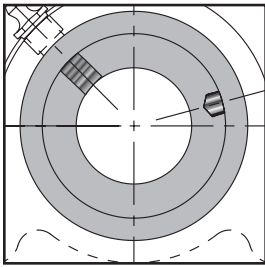

900 ECCENTRIC LOCK
Browning roller bearings have an eccentric locking collar that mates with the inner race for shaft hold. One end of the inner race is machined to a cam form and the mating lock collar has an off center counterbore. The wedge action of the collar on the

inner race secures the inner race to the shaft. This locking method tends to tighten and grip the shaft and not leave burrs as with setscrew collars.

NOTE: Eccentric collars are not recommended for reversing applications.

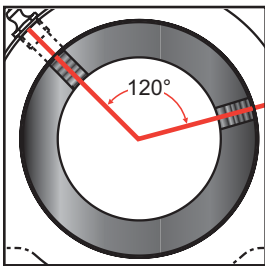

E920 SETSCREW LOCK
This locking device has two lock collars with two setscrews to anchor the bearing to the inner race. The elastic deflection of the collar serves to help retain the bearing hold to the shaft. Double locking collars with setscrews at 120° provide improved

holding power and shaft lock especially in applications with heavy vibration or unidirectional loads. Browning lock collars are black oxide coated for corrosion resistance.

SEALS

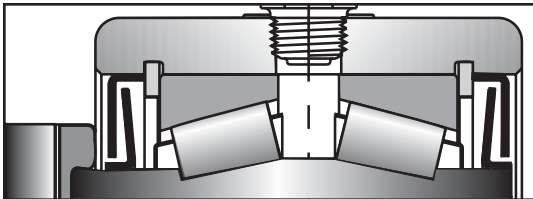

900 SEALS - CENTRAP® labyrinth seals contain an angled flinger that rotates with the shaft, creating a centrifugal force to help keep out contamination. Excess grease purges from the seal to help remove contaminants caught in the lubricant and prevent seal damage from over lubrication. The non-contact labyrinth design reduces drag, saves energy and normally cannot be blown by overgreasing.

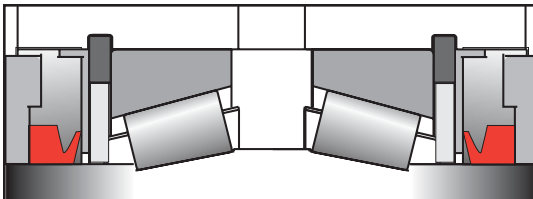

E920 SEALS - Rubber contact face seals are designed to retain lubricant and help exclude contaminants. The seal is designed with a long flexible face that seals axially against the counterface. The contact seal is self purging. It retains low torque characteristics and rotates with the shaft to help reduce contaminant build-up on the seal. Its low friction reduces heat generation and wear.

See page 156 for trademark acknowledgments.

BROWNING TAPERED ROLLER BEARINGS 900/E920 SERIES FEATURES/BENEFITS

HOUSING



DUCTILE

900 HOUSING - 900 Series ductile iron housings are approximately twice as strong as cast iron. This is an important feature in applications such as sawmills where heavy loads and shock conditions are normally experienced. Elongated bolt holes in the housing base permit easy replacement of competitive pillow blocks and more adjustment capability.



CAST IRON

E920 HOUSING- Browning compact solid one piece cast iron housings provide strength and load support in a wide variety of applications. Elongated bolt holes in the housing base permit easy replacement of competitive pillow blocks and more adjustment capability.

TABLE OF CONTENTS

PB900 Pillow Blocks	104
FB900 Flange Blocks	105
FC900 Flange Cartridges ...	106
TU900 Take-Ups	108
T900 Take-Up Frames	109
900 Ratings	114
900 Interchange Tables	166
PBE920 Pillow Blocks	110
FBE920 Flange Blocks	111
TUE900 Take-Ups	112
T1000 Take-Up Frames	113
E920 Ratings	115
E920 Interchange Tables	166
950/970	116
1000/1100	126
22200/22500	140

Tapered Roller Bearings

PB900

Lock: Eccentric
 Seal: CENTRAP[®] Labyrinth
 Housing: Ductile Iron
 Temperatures: -20°F to 200°F
 Fitting: 1/8" NPT
 Bearing Insert: Tapered Roller

Load Rating Tables: Page 114
 Interchange Tables: Page 166

P PILLOW
B BLOCK
9 900 SERIES
0 ECCENTRIC
0 TAPERED ROLLER BEARING

**Dimensional Interchange
 with most Type E's**

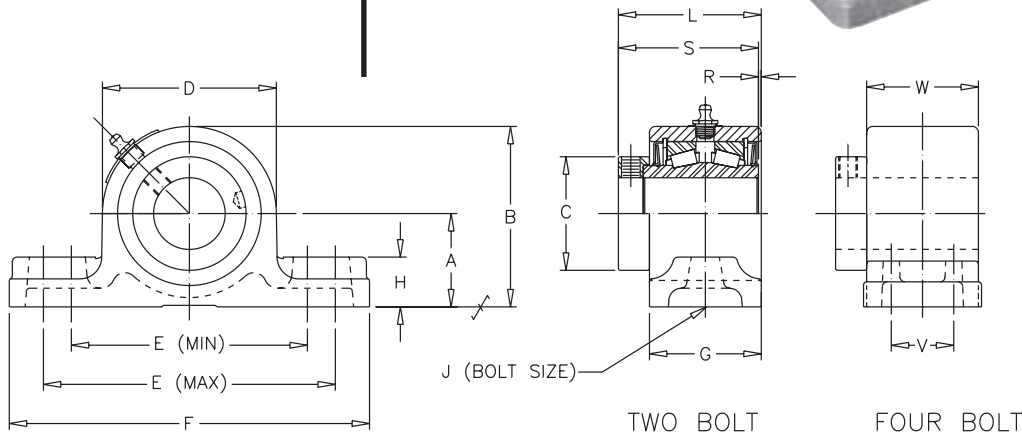

SHAFT DIA. IN	Dimensions In Inches															UNIT WT.
	A	B	C	D	E		F	G	H	J	L	R	S	V	W	
					MIN.	MAX.										
TWO BOLT BASE																
1	1 9/16	3 1/32	1 15/16	2 15/16	4 1/8	4 5/8	5 7/8	2 1/8	3/4	1/2	2 21/32	5/64	2 35/64	-	-	4.4
1 3/16																
1 1/4	1 3/4	3 13/32	2 3/16	3 5/16	4 1/2	5	6 3/8	2 1/4	3/4	1/2	2 13/16	1/16	2 3/4	-	-	5.7
1 3/8																
1 7/16	1 7/8	3 5/8	2 3/16	3 1/2	4 3/4	5 7/8	7 1/4	2 1/4	1	1/2	2 7/8	1/16	2 13/16	-	-	6.3
1 1/2																
1 5/8																
1 15/16	2 1/8	4	2 1/2	3 3/4	5 1/4	6 3/8	7 3/4	2 3/8	1 1/8	1/2	2 15/16	1/8	2 13/16	-	-	7.7
1 3/4																
1 7/8																
1 15/16	2 1/4	4 17/32	3	4 9/16	6	7 1/8	8 7/8	2 7/16	1 1/4	5/8	3 5/32	3/32	3 1/16	-	-	11.2
2																
2 1/8																
2 3/16	2 1/2	4 31/32	3 3/8	4 15/16	6 1/2	7 7/8	9 5/8	2 1/2	1 1/4	5/8	3 7/32	3/32	3 1/8	-	-	13.1
2 1/4																
2 7/16	2 3/4	5 5/8	3 3/8	5 1/4	6 7/8	8 5/8	10 3/8	2 13/16	1 3/8	5/8	3 29/64	5/32	3 1/4	-	-	16.3
2 1/2																
2 11/16																
2 3/4	3 1/8	6 1/16	4	5 7/8	7 7/8	9 5/8	11 5/8	2 5/8	1 3/8	3/4	3 15/32	3/32	3 3/8	-	-	19.9
2 15/16																
3																
3 3/16	3 5/16	6 9/16	4 1/4	6 1/2	8 3/8	9 3/4	11 3/4	3 1/8	1 5/8	3/4	3 31/32	3/32	3 7/8	-	-	26.8
3 7/16																
3 1/2	3 3/4	7 3/8	4 11/16	7 1/4	9 3/8	11 1/4	13 1/2	3 1/8	1 7/8	7/8	4 5/64	1/16	4	-	-	34.1
3 15/16																
4	4 1/8	8	5 1/4	7 3/4	10 1/16	11 11/16	14 1/4	3 7/8	2	1	4 29/32	5/32	4 3/4	-	-	47.7
FOUR BOLT BASE																
4 7/16	4 3/4	9 1/8	6 1/8	8 3/4	11 3/4	13 3/4	15 7/8	4 1/2	2 1/4	3/4	5 7/16	1/16	5 3/16	2 1/2	4 1/8	65.0
4 1/2																
4 15/16	5 1/2	10 1/16	6 5/8	9 1/8	13 3/4	15 3/4	18 1/8	5	2 1/2	7/8	5 27/32	3/32	5 3/8	2 3/4	4 1/4	77.0
5																

Part Numbers are specified by "PB900" and bore size: Example **PB900x 1 3/16"**.
 Bearings with Eccentric Locking Collars are not recommended for reversing applications.

Tapered Roller Bearings



FLANGE F
BLOCK B

900 SERIES 9
ECCENTRIC LOCK 0
TAPERED ROLLER BEARING 0

**Dimensional Interchange
with most Type E's**

FB900

Lock: Eccentric
Seal: CENTRAP® Labyrinth
Housing: Ductile Iron
Temperatures: -20°F to 200°F
Fitting: 1/8" NPT
Bearing Insert: Tapered Roller

Load Rating Tables: Page 114
Interchange Tables: Page 166

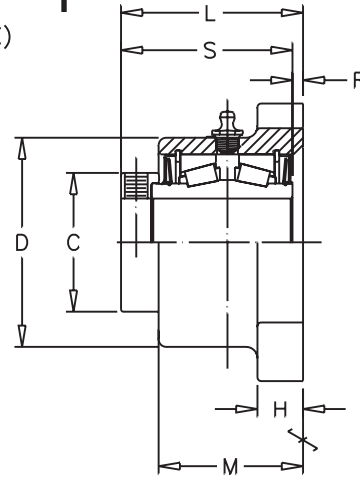
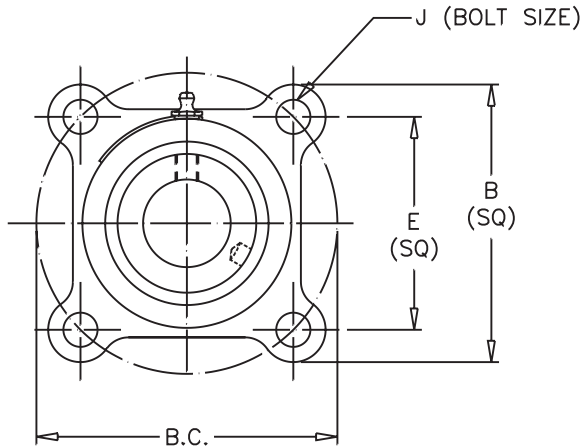

SHAFT DIA. IN.	Dimensions in Inches											UNIT WT.
	B	B.C.	C	D	E	H	J	L	M	R	S	
1	3 5/8	3 7/8	1 15/16	2 15/16	2 3/4	9/16	3/8	2 23/32	2 1/8	11/64	2 35/64	3.9
1 3/16												
1 1/4	3 7/8	4 1/4	2 3/16	3 1/4	3	5/8	3/8	2 15/16	2 3/8	11/64	2 3/4	4.9
1 3/8												
1 7/16	4 9/16	4 61/64	2 3/16	3 7/16	3 1/2	3/4	1/2	3	2 3/8	11/64	2 13/16	5.5
1 1/2												
1 5/8												
1 11/16	5 1/4	5 53/64	2 1/2	3 11/16	4 1/8	7/8	1/2	3 1/16	2 1/2	1/4	2 13/16	7.0
1 3/4										1/4		
1 7/8												
1 15/16	5 1/2	6 3/16	3	4 1/2	4 3/8	7/8	1/2	3 9/32	2 9/16	7/32	3 1/16	10.2
2												
2 1/8												
2 3/16	6 3/16	6 57/64	3 3/8	4 7/8	4 7/8	1	5/8	3 11/32	2 5/8	7/32	3 1/8	12.3
2 1/4												
2 7/16	6 3/4	7 19/32	3 3/8	5 3/16	5 3/8	1	5/8	3 29/64	2 11/16	13/64	3 1/4	14.8
2 1/2												
2 11/16												
2 3/4	7 5/8	8 31/64	4	5 3/4	6	1 1/16	3/4	3 19/32	2 3/4	7/32	3 3/8	18.7
2 15/16												
3												
3 3/16	7 7/8	8 53/64	4 1/4	6 3/8	6 1/4	1 1/4	3/4	4 5/32	3 5/16	9/32	3 7/8	26.2
3 7/16												
3 1/2	8 5/8	9 57/64	4 11/16	7 1/8	7	1 5/16	3/4	4 17/64	3 5/16	17/64	4	33.1
3 15/16												
4	9 7/8	10 61/64	5 1/4	7 11/16	7 3/4	1 1/2	7/8	5 3/32	4 1/16	21/64	4 3/4	47.1
4 7/16												
4 1/2	10 7/8	12 3/8	6 1/8	8 3/4	8 3/4	1 1/2	7/8	5 7/16	4 5/16	1/4	5 3/16	64.0

Part Numbers are specified by "FB900" and bore size: Example **FB900x 1 3/16"**.
Bearings with Eccentric Locking Collars are not recommended for reversing applications.



FC900

Lock: Eccentric
Seal: CENTRAP® Labyrinth
Housing: Cast Iron
Temperatures: -20°F to 200°F
Fitting: 1/8" NPT
Bearing Insert: Tapered Roller

Load Rating Tables: Page 114
Interchange Tables: Page 166

F FLANGE
C CARTRIDGE

9 900 SERIES
0 ECCENTRIC LOCK
0 TAPERED ROLLER BEARING

**Dimensional Interchange
with most Type E's**

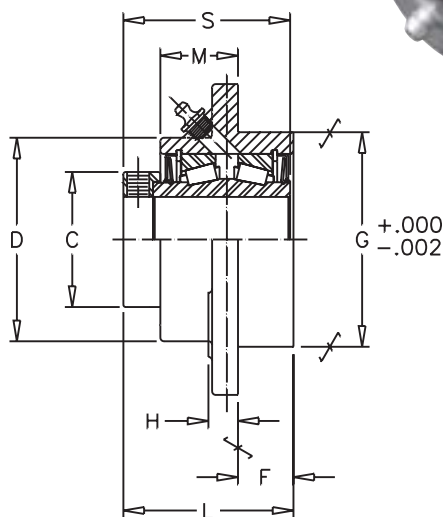
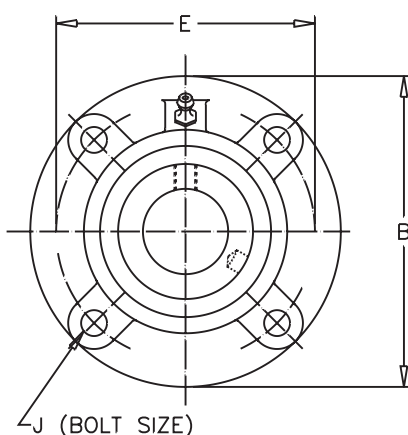

SHAFT DIA. IN.	Dimensions In Inches											UNIT WT.
	B	C	D	E	F	G	H	J	L	M	S	
1	4 3/8	1 15/16	2 15/16	3 5/8	15/16	3	7/16	5/16	2 19/32	1 1/16	2 35/64	4.0
1 3/16	5	2 3/16	3 1/4	4 1/8	1	3 3/8	7 16	3/8	2 13/16	1 1/4	2 3/4	5.3
1 1/4												
1 3/8												
1 7/16	5 1/4	2 3/16	3 7/16	4 3/8	15/16	3 5/8	1/2	3/8	2 7/8	1 5/16	2 13/16	6.0
1 1/12												
1 5/8												
1 11/16	6 1/8	2 1/2	3 11/16	5 1/8	1 1/16	4 15/64	1/2	3/8	2 15/16	1 5/16	2 13/16	7.9
1 3/4												
1 7/8												
1 15/16	6 3/8	3	4 1/2	5 3/8	1 1/16	4 1/2	9/16	3/8	3 5/32	1 3/8	3 1/16	10.0
2												
2 18												
2 3/16	7 1/8	3 3/8	4 7/8	6	1 1/8	5	9/16	1/2	3 7/32	1 3/8	3 1/8	14.0
2 1/4												
2 7/16												
2 1/2	7 5/8	3 3/8	5 3/16	6 1/2	1 1/8	5 1/2	5/8	1/2	3 21/64	17/16	3 1/4	15.5
2 11/16												
2 3/4												
2 15/16	8 3/4	3 7/16	5 3/4	7 1/2	1 1/4	6 3/8	3/4	5/8	3 15/32	1 3/8	3 3/8	21.6
3												
3 3/16												
3 7/16	10 1/4	4 11/16	7 1/8	8 5/8	1 5/16	7 3/8	15/16	3/4	4 5/64	1 13/16	4	40.0
3 1/2												

Part Numbers are specified by "FC900" and bore size: Example **FC900x 1 3/16"**.
 Bearings with Eccentric Locking Collars are not recommended for reversing applications.

Browning®

Roller Bearings

Part Number Explanation

Tapered Roller Bearings Series (900, E920, 970, 950)

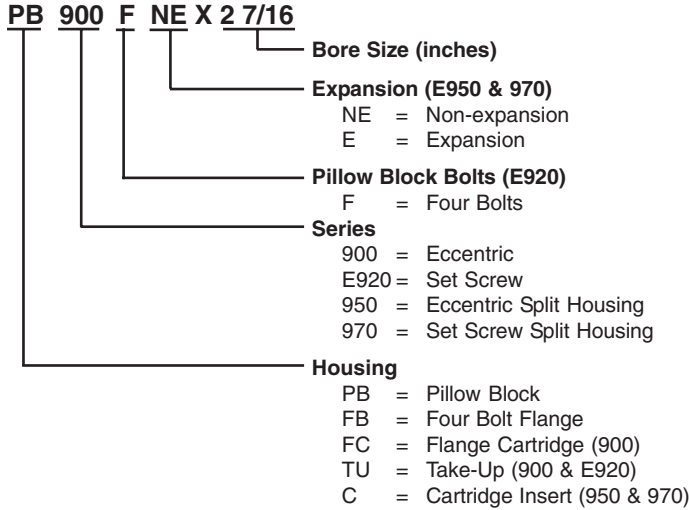

Take-Up Frames

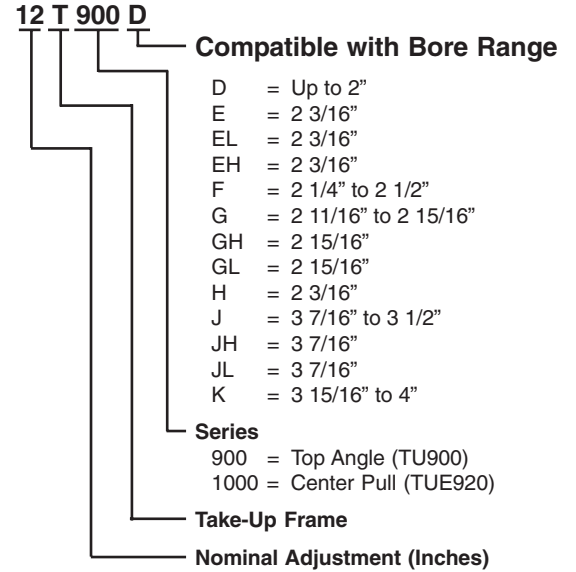

Spherical Roller Bearings Series (1000, 1100)

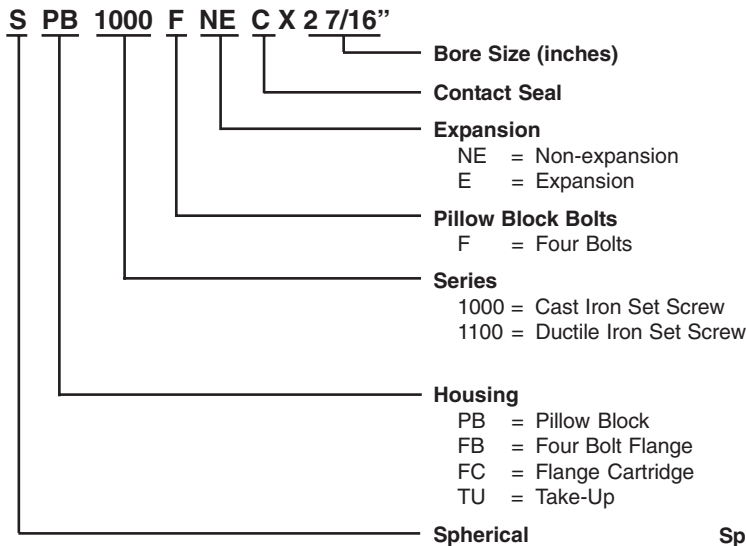

Spherical Roller Bearings Series (22500, 22200)

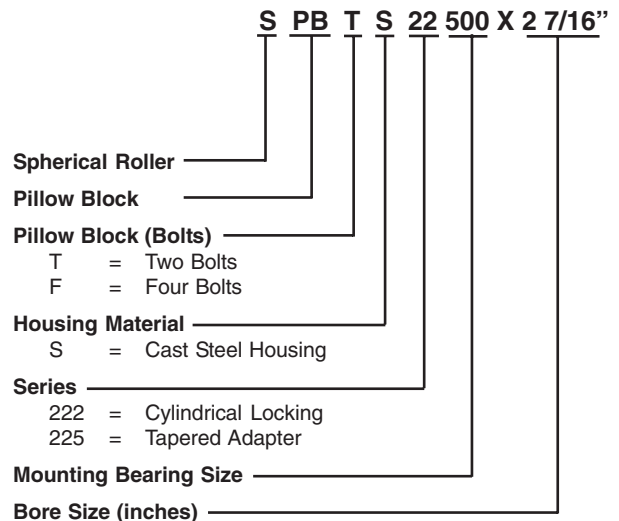



Tapered Roller Bearings

TU900

Lock: Eccentric
Seal: CENTRAP[®] Labyrinth
Housing: Ductile Iron
Temperatures: - 20°F to 200°F
Fitting: 1/8" NPT
Bearing Insert: Tapered Roller

Load Rating Tables: Page 114
Interchange Tables: Page 166

T TAKE
U UP

9 900 SERIES
0 ECCENTRIC LOCK
0 TAPERED ROLLER BEARING

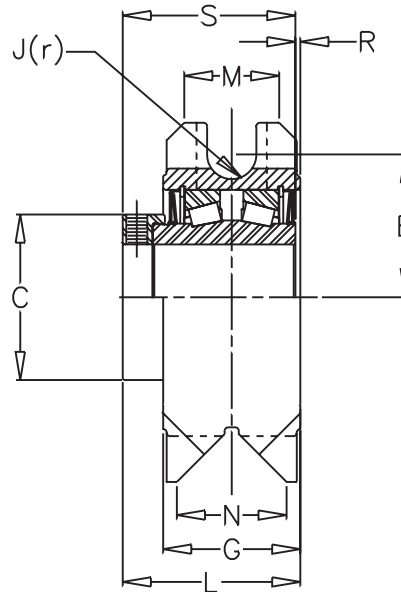
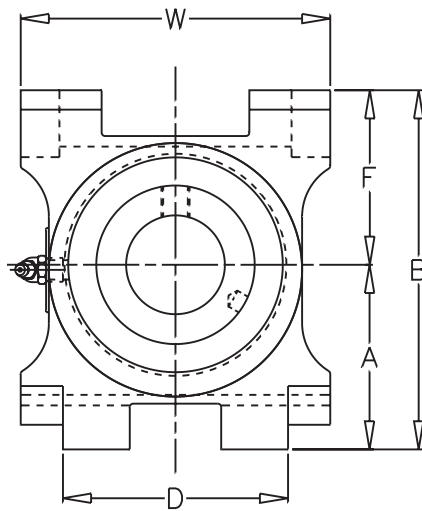

SHAFT DIA. IN.	Dimensions in Inches														UNIT WT.
	A	B	C	D	E	F	G	J	L	M	N	R	S	W	
1 7/8															
1 15/16															
2	3 9/32	6 3/8	3	4	2 17/32	3 3/32	2 7/16	7/16	3 5/32	1 11/16	1 61/64	3/32	3 1/16	5 1/2	13.9
2 1/8															
2 3/16	3 17/32	6 15/16	3 3/8	4	2 27/32	3 13/32	2 1/2	7/16	3 7/32	1 11/16	2 5/64	3/32	3 1/8	6	16.6
2 1/4															
2 7/16	3 23/32	7 9/16	3 3/8	4 5/8	3 3/32	3 27/32	2 9/16	9/16	3 21/64	1 7/8	2 9/64	5/64	3 1/4	6 1/2	19.6
2 1/2															
2 11/16															
2 3/4	4 1/32	8 3/16	4	4 5/8	3 7/16	4 5/32	2 5/8	9/16	3 15/32	1 7/8	2 13/64	3/32	3 3/8	7	24.0
2 15/16															
3 7/16															
3 1/2	4 49/64	9 7/8	4 11/16	5 3/4	4 11/64	5 7/64	3 1/8	11/16	4 5/64	2 1/4	2 11/16	5/64	4	8 1/2	41.8
3 15/16															
4	5 17/32	10 7/8	5 1/4	5 3/4	4 15/32	5 11/32	3 7/8	11/16	4 29/32	2 1/4	3 9/32	5/32	4 3/4	9 1/4	61.0

Part Numbers are specified by "TU900" and bore size: Example **TU900x 1 3/16"**.
 Bearings with Eccentric Locking Collars are not recommended for reversing applications.

Tapered Roller Bearings

T900

TAKE UP FRAME T

900 SERIES 9

ECCENTRIC LOCK 0

TAPERED ROLLER BEARING 0

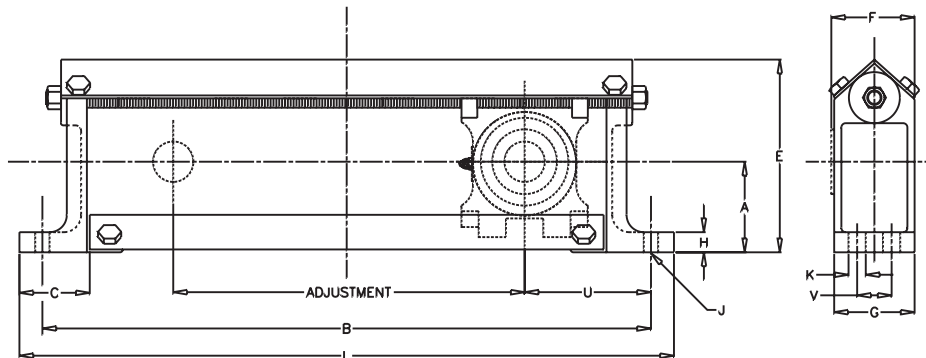

FRAME PART NO.	BORE RANGE	Adjustment*		Dimensions In Inches												UNIT WT.
		Nominal	Actual	A	B	C	E	F	G	H	J	K	L	U	V	
12T900D	1 7/8-2	12	15 1/2	3 15/16	26 1/2	2 15/16	8 3/8	3 11/16	3 1/2	7/8	5/8	1	28 1/2	5 1/2	-	31.5
18T900D	1 7/8-2	18	21 1/2	3 15/16	32 1/2	2 15/16	8 3/8	3 11/16	3 1/2	7/8	5/8	1	34 1/2	5 1/2	-	37.2
24T900D	1 7/8-2	24	27 1/2	3 15/16	38 1/2	2 15/16	8 3/8	3 11/16	3 1/2	7/8	5/8	1	40 1/2	5 1/2	-	41.7
12T900E	2 3/16	12	16 1/2	4 3/16	27 1/2	3 11/32	8 15/16	3 23/32	3 1/2	7/8	5/8	1	29 1/2	5 1/2	-	32.8
18T900E	2 3/16	18	22 1/2	4 3/16	33 1/2	3 11/32	8 15/16	3 23/32	3 1/2	7/8	5/8	1	35 1/2	5 1/2	-	38.6
24T900E	2 3/16	24	28 1/2	4 3/16	39 1/2	3 11/32	8 15/16	3 23/32	3 1/2	7/8	5/8	1	41 1/2	5 1/2	-	44.6
12T900F	2 1/4-2 1/2	12	16	4 3/8	28 1/2	3 7/16	9 21/32	4 3/64	4	7/8	3/4	1 5/16	30 1/2	6 1/4	-	43.8
18T900F	2 1/4-2 1/2	18	22	4 3/8	34 1/2	3 7/16	9 21/32	4 3/64	4	7/8	3/4	1 5/16	36 1/2	6 1/4	-	50.0
24T900F	2 1/4-2 1/2	24	28	4 3/8	40 1/2	3 7/16	9 21/32	4 3/64	4	7/8	3/4	1 5/16	42 1/2	6 1/4	-	55.0
12T900G	2 11/16-2 15/16	12	17 1/2	5	30 1/2	3 31/32	10 11/16	4 1/2	4 1/2	7/8	5/8	1	32 1/2	6 1/2	2	56.5
18T900G	2 11/16-2 15/16	18	23 1/2	5	36 1/2	3 31/32	10 11/16	4 1/2	4 1/2	7/8	5/8	1	38 1/2	6 1/2	2	63.5
24T900G	2 11/16-2 15/16	24	29 1/2	5	42 1/2	3 31/32	10 11/16	4 1/2	4 1/2	7/8	5/8	1	44 1/2	6 1/2	2	72.5
12T900J	3 7/16-3 1/2	12	17 5/8	5 1/2	32	4	12 7/32	4 49/64	4 1/2	7/8	3/4	1	34 1/4	7 1/8	2	72.0
18T900J	3 7/16-3 1/2	18	23 5/8	5 1/2	38	4	12 7/32	4 49/64	4 1/2	7/8	3/4	1	40 1/4	7 1/8	2	78.0
24T900J	3 7/16-3 1/2	24	29 5/8	5 1/2	44	4	12 7/32	4 49/64	4 1/2	7/8	3/4	1	46 1/4	7 1/8	2	85.0
12T900K	3 15/16-4	12	20 1/8	7	36	4 1/2	14 1/16	5 23/32	5 1/2	7/8	3/4	1	38 1/2	7 7/8	2 1/2	76.0
18T900K	3 15/16-4	18	26 1/8	7	42	4 1/2	14 1/16	5 23/32	5 1/2	7/8	3/4	1	44 1/2	7 7/8	2 1/2	85.0
24T900K	3 15/16-4	24	32 1/8	7	48	4 1/2	14 1/16	5 23/32	5 1/2	7/8	3/4	1	50 1/2	7 7/8	2 1/2	94.0

Part Numbers are specified by "T900" with travel adjustment and bore size: Example, **12T900F** has 12"-16" adjustment and will accommodate a TU900x 2 1/4" - TU900x 2 1/2" bearing unit.

These Take-Up Frames are to be used with Take-Up Units shown on page 108. Bearing unit and frame must be ordered separately.



PBE920

Lock: Set Screw
Seal: Contact
Housing: Cast Iron
Temperatures: -20° to 200°F
Fitting: 1/8" NPT
Bearing Insert: Tapered Roller

Load Rating Tables: Page 115
Interchange Tables: Page 166

P PILLOW
B BLOCK
E TYPE 'E'

9 920
2 SET SCREW LOCK
0 TAPERED ROLLER BEARING

Dimensional Interchange with most Type E's

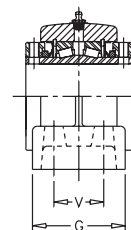
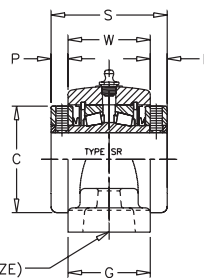
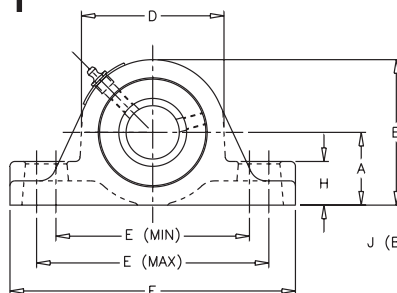
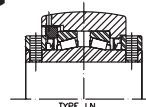

TWO BOLT

FOUR BOLT

SHAFT DIA. IN.	TYPE	Dimensions in Inches														UNIT WT.
		A	B	C	D	E		F	G	H	J	P	S	V	W	
						MIN	MAX									
TWO BOLT BASE																
1 3/16	SR	1 1/2	3	2 1/4	3	4 5/16	5	6 3/8	1 7/8	7/8	1/2	29/64	2 25/32	-	1 7/8	4.0
1 1/4						5	6	7 3/8	2 1/8	1 1/8	1/2	7/16	3	-	2 1/8	6.9
1 3/8	SR	1 7/8	3 3/4	2 3/4	3 5/8	5	6	7 3/8	2 1/8	1 1/8	1/2	7/16	3	-	2 1/8	6.9
1 7/16																
1 1/2	SR	2 1/8	4 1/4	3 3/16	4 1/4	5 11/16	6 1/2	7 7/8	2 1/2	1 1/4	1/2	15/32	3 3/8	-	2 1/2	9.5
1 5/8						6 1/2	7 7/8	2 1/2	1 1/4	1/2	15/32	3 3/8	-	2 1/2	9.5	
1 11/16	SR	2 1/4	4 1/2	3 7/16	4 1/2	6 3/16	7 1/4	8 7/8	2 1/2	1 1/4	5/8	1/2	3 1/2	-	2 1/2	11.0
1 3/4						7 1/4	8 7/8	2 1/2	1 1/4	5/8	1/2	3 1/2	-	2 1/2	11.0	
1 15/16	SR	2 1/4	4 1/2	3 7/16	4 1/2	6 3/16	7 1/4	8 7/8	2 1/2	1 1/4	5/8	1/2	3 1/2	-	2 1/2	11.0
2						7 1/4	8 7/8	2 1/2	1 1/4	5/8	1/2	3 1/2	-	2 1/2	11.0	
2 3/16	SR	2 1/2	5	3 3/4	5	6 11/16	8	9 5/8	2 5/8	1 7/16	5/8	9/16	3 3/4	-	2 5/8	14.0
2 1/4	SR	2 3/4	5 1/2	4 1/16	5 3/8	7 1/8	8 3/4	10 1/2	2 7/8	1 5/8	5/8	9/16	4	-	2 7/8	19.0
2 7/16																
2 1/2	SR	3 1/8	6 1/4	4 23/32	6 1/4	8 7/16	9 3/4	12	3	1 3/4	3/4	3/4	4 1/2	-	3	26.0
2 11/16																
2 3/4	SR	3 1/8	6 1/4	4 23/32	6 1/4	8 7/16	9 3/4	12	3	1 3/4	3/4	3/4	4 1/2	-	3	26.0
2 15/16																
3	LN	3 3/4	7 1/2	5 7/16	7 5/8	9 3/4	11 1/2	14	3 5/8	2 1/8	7/8	11/16	5	-	3 5/8	44.0
3 3/16																
3 7/16	LN	3 3/4	7 1/2	5 7/16	7 5/8	9 3/4	11 1/2	14	3 5/8	2 1/8	7/8	11/16	5	-	3 5/8	44.0
3 1/2																
FOUR BOLT BASE																
2 1/4	SR	2 3/4	5 1/2	4 1/16	5 3/8	7 1/8	8 3/4	10 1/2	3 1/2	1 5/8	5/8	9/16	4	1 7/8	2 7/8	19.0
2 7/16																
2 1/2	SR	3 1/8	6 1/4	4 23/32	6 1/4	8	9 7/8	12	4	1 3/4	5/8	3/4	4 1/2	2 1/8	3	26.0
2 11/16																
2 3/4	SR	3 1/8	6 1/4	4 23/32	6 1/4	8	9 7/8	12	4	1 3/4	5/8	3/4	4 1/2	2 1/8	3	26.0
2 15/16																
3	LN	3 3/4	7 1/2	5 7/16	7 1/2	9 11/16	11 7/16	14	4 1/2	2 1/8	3/4	11/16	5	2 3/8	3 5/8	44.0
3 3/16																
3 7/16	LN	3 3/4	7 1/2	5 7/16	7 1/2	9 11/16	11 7/16	14	4 1/2	2 1/8	3/4	11/16	5	2 3/8	3 5/8	44.0
3 1/2																
3 15/16	LN	4 1/4	8 1/2	5 15/16	8 1/2	10 7/16	12 7/8	15 1/4	4 1/2	2 7/16	3/4	7/8	6 1/4	2 1/4	4 1/2	65.0
4	LN	4 3/4	9 3/8	6 13/32	9 1/8	11 1/4	13 7/8	16 5/8	4 5/8	2 3/4	3/4	1 1/16	6 3/4	2 1/2	4 5/8	81.0
4 7/16																
4 1/2	LN	5 1/2	10 7/8	7 13/32	10 3/4	13	15 7/8	18 1/2	5 1/8	3 1/8	7/8	1 1/16	7 1/4	2 3/4	5 1/8	132.0
4 15/16																
5																

Part Numbers are specified by "PBE920" and bore size: Example, **PBE920x 1 3/16"**.
 Add "F" for Four Bolt Base: Example, **PBE920Fx 2 7/16"**.

Tapered Roller Bearings

FBE920



FLANGE F
BLOCK B
TYPE 'E' E

920 9
SET SCREW LOCK 2
TAPERED ROLLER BEARING 0

**Dimensional Interchange
with most Type E's**

Lock: Set Screw
Seal: Contact
Housing: Cast Iron
Temperatures: -20° to 200°F
Fitting: 1/8" NPT
Bearing Insert: Tapered Roller

Load Rating Tables: Page 115
Interchange Tables: Page 166

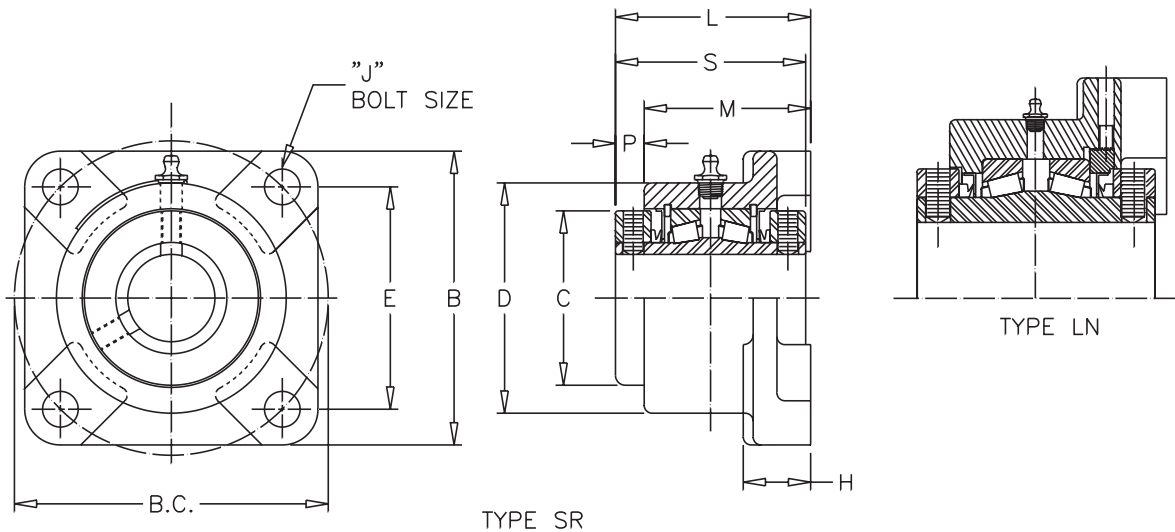

SHAFT DIA. IN.	TYPE	Dimensions In Inches											UNIT WT.
		B	B.C	C	D	E	H	J	L	M	P	S	
1 3/16 1 1/4	SR	3 3/4	4 1/16	2 1/4	3	2 7/8	1 1/32	3/8	2 27/32	2 3/8	15/32	2 25/32	4.5
1 3/8 1 7/16	SR	4 5/8	4 61/64	2 3/4	3 5/8	3 1/2	1 1/16	1/2	3 5/64	2 5/8	29/64	3	6.7
1 1/2 1 5/8 1 11/16	SR	5 3/8	5 53/64	3 3/16	4 1/4	4 1/8	1 3/16	1/2	3 29/64	3	29/64	3 3/8	10.0
1 3/4 1 15/16 2	SR	5 5/8	6 3/16	3 7/16	4 1/2	4 3/8	1 3/16	1/2	3 5/8	3 1/8	1/2	3 1/2	12.0
2 3/16 2 1/4 2 7/16 2 1/2	SR	6 1/4	6 57/64	3 3/4	4 7/8	4 7/8	1 1/4	5/8	3 7/8	3 5/16	9/16	3 3/4	16.0
2 1/4 2 7/16 2 1/2	SR	6 7/8	7 39/64	4 1/16	5 1/4	5 3/8	1 1/2	5/8	4 3/16	3 5/8	9/16	4	21.0
2 11/16 2 3/4 2 15/16 3	SR	7 3/4	8 31/64	4 23/32	6 1/8	6	1 5/8	3/4	4 11/16	3 15/16	3/4	4 1/2	28.0
3 3/16 3 7/16 3 1/2	LN	9 1/4	9 29/32	5 7/16	7 1/2	7	1 7/8	3/4	5 1/4	4 9/16	11/16	5	46.0
3 15/16 4	LN	10 1/4	10 31/32	5 15/16	8 1/4	7 3/4	2 3/16	7/8	6 9/16	5 11/16	7/8	6 1/4	64.0

Part Numbers are specified by "FBE920" and bore size: Example, **FBE920x 1 3/16"**.



Tapered Roller Bearings

TUE920

Lock: Set Screw
Seal: Contact
Housing: Cast Iron
Temperatures: -20° to 200°F
Fitting: 1/8" NPT
Bearing Insert: Tapered Roller

Load Rating Tables: Page 115
Interchange Tables: Page 166

T TAKE
U UP
E TYPE 'E'

9 920
2 SET SCREW LOCK
0 TAPERED ROLLER BEARING

**Dimensional Interchange
with most Type E's**

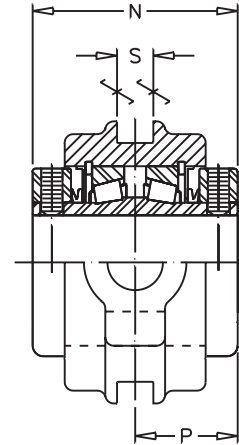
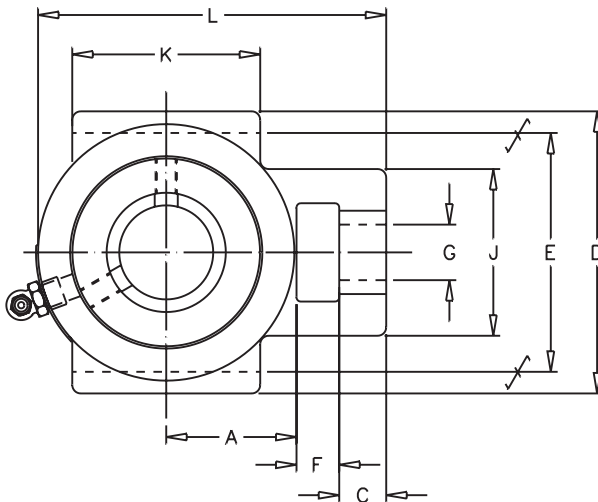

SHAFT DIA. IN.	Dimensions in Inches												UNIT WT.
	A	C	D	E	F	G	J	K	L	N	P	S	
*1 3/8													
*1 7/16	1 29/32	11/16	4 1/8	3 1/2	5/8	13/16	2 7/16	2 3/4	5 3/32	3	1 1/2	17/32	6.0
1 1/2													
1 11/16	2 1/8	5/8	4 3/4	4	1 1/16	1 1/16	2 7/8	3 1/4	6	3 3/8	1 11/16	11/16	9.0
1 3/4													
1 15/16	2 1/8	3/4	4 3/4	4	1 1/16	1 1/16	2 7/8	3 1/2	6 3/16	3 1/2	1 3/4	11/16	12.0
2													
2 3/16	2 3/8	3/4	5 1/4	4 1/2	1 3/16	1 3/16	3 1/2	3 3/4	6 13/16	3 3/4	1 7/8	13/16	16.0
2 7/16													
2 1/2	2 3/4	7/8	5 7/8	5 1/8	1 5/16	1 5/16	3 3/4	4 3/4	7 15/16	4	2	1 1/16	21.0
2 11/16													
2 3/4	3	1	6 3/4	5 15/16	1 9/16	1 9/16	4 1/4	4 3/4	8 3/4	4 1/2	2 1/4	1 13/16	30.0
2 15/16													
3 7/16	3 5/8	1	7 5/8	6 13/16	1 13/16	1 13/16	4 7/8	6 1/4	10 7/16	5	2 1/2	1 13/16	44.0
3 15/16	4 1/8	1 1/8	9 7/16	8 5/8	2 1/8	2 3/16	5 5/8	7	11 13/16	6 1/4	3 1/8	2 1/16	70.0
4 7/16	4 1/8	1 1/8	9 7/16	8 5/8	2 1/8	2 3/16	5 5/8	7	11 13/16	6 3/4	3 3/8	2 1/16	74.0

Part Numbers are specified by "TUE920" and bore size: Example, TUE920x 1 3/16".

These Take-Up Bearings are to be used with Take-Up Frames shown on page 113.

Bearing unit and frame must be ordered separately.

* Take -Up frames not available in these sizes.

Tapered Roller Bearings

T1000



TAKE UP FRAME T

**1000 SERIES 1
0
0
0**

Material: All Steel Construction

Exclusive Design: Removable Top Permits Assembling of Take-Up Unit on Shaft Before Inserting in Take-Up Frame.

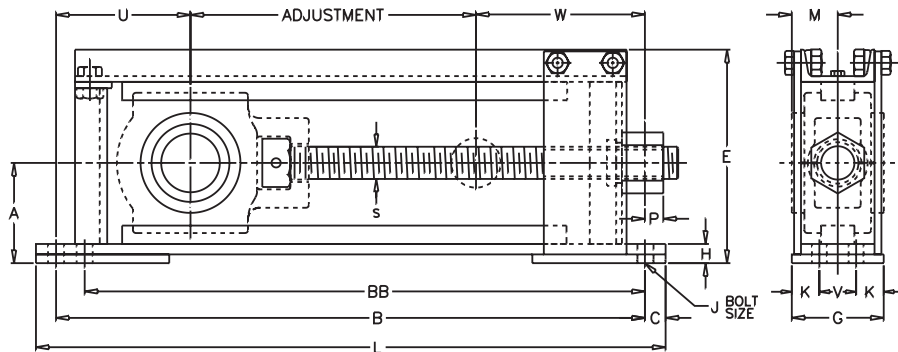

SHAFT DIA. IN	FRAME PART NO.	Adjustment*		Dimensions in Inches															Bolts Req'd		UNIT WT.
		Nom.	Actual	A	B	BB	C	E	G	H	K	L	M	S	P	U	V	W	No.	Size J	
1 1/2		12	16.5	3 15/16	27 1/2	26 1/2	1	8 9/32	4	1 1/4	-	29 1/2	1 7/8	1-8NC	1 1/4	5 3/8	-	5 5/8	2	5/8	60
1 11/16		18	22.5	3 15/16	33 1/2	32 1/2	1	8 9/32	4	1 1/4	-	35 1/2	1 7/8	1-8NC	1 1/4	5 3/8	-	5 5/8	2	5/8	70
1 3/4	12-16.5T1000D	24	28.5	3 15/16	39 1/2	38 1/2	1	8 9/32	4	1 1/4	-	41 1/2	1 7/8	1-8NC	1 1/4	5 3/8	-	5 5/8	2	5/8	80
1 15/16	18-22.5T1000D	12	17	4 3/16	27 1/2	-	1	8 21/32	4	1 3/8	-	29 1/2	2	1 1/8-7NC	1 5/8	4 9/16	-	5 15/16	2	5/8	65
2	18-23T1000EL	18	23	4 3/16	33 1/2	-	1	8 21/32	4	1 3/8	-	35 1/2	2	1 1/8-7NC	1 5/8	4 9/16	-	5 15/16	2	5/8	77
2 3/16	24-29T1000EL	24	29	4 3/16	39 1/2	-	1	8 21/32	4	1 3/8	-	41 1/2	2	1 1/8-7NC	1 5/8	4 9/16	-	5 15/16	2	5/8	86
2 3/16	12-17T1000EH	12	17	4 7/16	27 1/2	-	1	8 29/32	4	1 5/8	-	29 1/2	2	1 1/8-7NC	1 5/8	4 9/16	-	5 15/16	2	5/8	68
2 3/16	18-23T1000EH	18	23	4 7/16	33 1/2	-	1	8 29/32	4	1 5/8	-	35 1/2	2	1 1/8-7NC	1 5/8	4 9/16	-	5 15/16	2	5/8	80
2 3/16	24-29T1000EH	24	29	4 7/16	39 1/2	-	1	8 29/32	4	1 5/8	-	41 1/2	2	1 1/8-7NC	1 5/8	4 9/16	-	5 15/16	2	5/8	91
2 7/16	12-16.6T1000F	12	16.6	4 3/8	28 1/2	-	1	9 3/16	4	1 1/8	-	30 1/2	2 1/8	1 1/4-7NC	1 3/4	5 5/16	-	6 9/16	2	3/4	71
2 7/16	18-22.6T1000F	18	22.6	4 3/8	34 1/2	-	1	9 3/16	4	1 1/8	-	36 1/2	2 1/8	1 1/4-7NC	1 3/4	5 5/16	-	6 9/16	2	3/4	81
2 7/16	24-28.6T1000F	24	28.6	4 3/8	40 1/2	-	1	9 3/16	4	1 1/8	-	42 1/2	2 1/8	1 1/4-7NC	1 3/4	5 5/16	-	6 9/16	2	3/4	91
2 7/16	30-34.6T1000F	30	34.6	4 3/8	46 1/2	-	1	9 3/16	4	1 1/8	-	48 1/2	2 1/8	1 1/4-7NC	1 3/4	5 5/16	-	6 9/16	2	3/4	111
2 15/16	12-15.5T1000GL	12	15.5	4 15/16	30 1/2	-	1	10 11/16	5	31/32	1 1/2	32 1/2	2 3/8	1 1/2-6NC	1/2	6 1/2	2	8 1/2	4	5/8	105
2 15/16	18-21.5T1000GL	18	21.5	4 15/16	36 1/2	-	1	10 11/16	5	31/32	1 1/2	38 1/2	2 3/8	1 1/2-6NC	1/2	6 1/2	2	8 1/2	4	5/8	120
2 15/16	24-27.5T1000GL	24	27.5	4 15/16	42 1/2	-	1	10 11/16	5	31/32	1 1/2	44 1/2	2 3/8	1 1/2-6NC	1/2	6 1/2	2	8 1/2	4	5/8	135
2 15/16	30-33.5T1000GL	30	33.5	4 15/16	48 1/2	-	1	10 11/16	5	31/32	1 1/2	50 1/2	2 3/8	1 1/2-6NC	1/2	6 1/2	2	8 1/2	4	5/8	150
2 15/16	12-15.5T1000GH	12	15.5	5 1/8	30 1/2	-	1	10 7/8	5	1 5/32	1 1/2	32 1/2	2 3/8	1 1/2-6NC	1/2	6 1/2	2	8 1/2	4	5/8	109
2 15/16	18-21.5T1000GH	18	21.5	5 1/8	36 1/2	-	1	10 7/8	5	1 5/32	1 1/2	38 1/2	2 3/8	1 1/2-6NC	1/2	6 1/2	2	8 1/2	4	5/8	126
2 15/16	24-27.5T1000GH	24	27.5	5 1/8	42 1/2	-	1	10 7/8	5	1 5/32	1 1/2	44 1/2	2 3/8	1 1/2-6NC	1/2	6 1/2	2	8 1/2	4	5/8	141
2 15/16	30-33.5T1000GH	30	33.5	5 1/8	48 1/2	-	1	10 7/8	5	1 5/32	1 1/2	50 1/2	2 3/8	1 1/2-6NC	1/2	6 1/2	2	8 1/2	4	5/8	156
3 7/16	12-15.5T1000JL	12	15.5	5 7/16	32	-	1 1/8	11 5/8	5	1 1/32	1 1/2	34 1/4	2 19/32	1 3/4-5NC	1	7 5/16	2	9 3/16	4	3/4	138
3 7/16	18-21.5T1000JL	18	21.5	5 7/16	38	-	1 1/8	11 5/8	5	1 1/32	1 1/2	40 1/4	2 19/32	1 3/4-5NC	1	7 5/16	2	9 3/16	4	3/4	156
3 7/16	24-27.5T1000JL	24	27.5	5 7/16	44	-	1 1/8	11 5/8	5	1 1/32	1 1/2	46 1/4	2 19/32	1 3/4-5NC	1	7 5/16	2	9 3/16	4	3/4	173
3 7/16	30-33.5T1000JL	30	33.5	5 7/16	50	-	1 1/8	11 5/8	5	1 1/32	1 1/2	52 1/4	2 19/32	1 3/4-5NC	1	7 5/16	2	9 3/16	4	3/4	191
3 7/16	12-15.5T1000JH	12	15.5	5 5/8	32	-	1 1/8	11 13/16	5	1 7/32	1 1/2	34 1/4	2 19/32	1 3/4-5NC	1	7 5/16	2	9 3/16	4	3/4	145
3 7/16	18-21.5T1000JH	18	21.5	5 5/8	38	-	1 1/8	11 13/16	5	1 7/32	1 1/2	40 1/4	2 19/32	1 3/4-5NC	1	7 5/16	2	9 3/16	4	3/4	163
3 7/16	24-27.5T1000JH	24	27.5	5 5/8	44	-	1 1/8	11 13/16	5	1 7/32	1 1/2	46 1/4	2 19/32	1 3/4-5NC	1	7 5/16	2	9 3/16	4	3/4	179
3 7/16	30-33.5T1000JH	30	33.5	5 5/8	50	-	1 1/8	11 13/16	5	1 7/32	1 1/2	52 1/4	2 19/32	1 3/4-5NC	1	7 5/16	2	9 3/16	4	3/4	197
3 15/16	12-18T1000K	12	18	7	36	-	1 1/4	14 15/32	6	1 7/16	1 3/4	38 1/2	2 31/32	2-4 1/2NC	1 5/8	7 1/2	2 1/2	10 7/16	4	3/4	191
4 7/16	18-24T1000K	18	24	7	42	-	1 1/4	14 15/32	6	1 7/16	1 3/4	44 1/2	2 31/32	2-4 1/2NC	1 5/8	7 1/2	2 1/2	10 7/16	4	3/4	223
4 1/2	24-30T1000K	24	30	7	48	-	1 1/4	14 15/32	6	1 7/16	1 3/4	50 1/2	2 31/32	2-4 1/2NC	1 5/8	7 1/2	2 1/2	10 7/16	4	3/4	249
4 1/2	30-36T1000K	30	36	7	54	-	1 1/4	14 15/32	6	1 7/16	1 3/4	56 1/2	2 31/32	2-4 1/2NC	1 5/8	7 1/2	2 1/2	10 7/16	4	3/4	274

Part Numbers are specified by "T1000" with travel adjustment and bore size: Example, 12-16.6T1000F has 12"-16.6" adjustment and will accommodate a TUE920x 2 7/16" bearing unit.

These Take-Up Frames are to be used with Take-Up Units shown on page 112.

Bearing unit and frame must be ordered separately.

* Nominal adjustment is that offered by competitive frames having the same length.

Browning frames give greater ACTUAL adjustment, often permitting use of shorter, more compact frames.

Browning frames with over 12" nominal adjustment have a third foot in the center for extra support.

See page 156 for trademark acknowledgments.



Tapered Roller Bearings

Tapered Roller Bearing 900 and 950 Series

This chart displays the Browning 900 and 950 Series Tapered Roller Bearing's load capacity for a given L10 life, speed and shaft size. Values in the table represent loads at ideal conditions. The shaded areas indicate the maximum speed for the 950 series only. Select 950 Series where aligning capability is required. For combined load determination, see **THE BEARING SELECTION SECTION**, page 268. Areas designated by “-” exceed maximum speed value.

Match Bore Size

SIZE	"K" FACTOR	2 ROW RATING	1 ROW RATING	THRUST RATING*	L10 HOURS	REVOLUTIONS PER MINUTE													
						50	100	150	250	500	750	1000	1500	1750	2000	2500	3000	3500	
1	1.42	3700	2130	1500	5000	4179	4179	4179	3908	3174	2578	2283	2094	1854	1771	2094	1959	1854	1771
					10000	4179	4179	3700	3174	2578	2283	2094	1854	1771	1701	1591	1506	1438	
					30000	3700	3005	2611	2283	1854	1642	1506	1334	1273	1223	1144	1083	1034	
					50000	3174	2578	2283	1959	1591	1409	1292	1144	1093	1050	982	929	887	
					100000	2578	2094	1854	1591	1292	1144	1050	929	887	853	797	755	721	
1 3/16	1.53	5130	2950	1930	5000	5794	5794	5794	5418	4401	3897	3575	3165	3022	2904	2716	2571	2455	
					10000	5794	5794	5130	4401	3575	3165	2904	2571	2455	2358	2206	2088	1944	
					30000	5130	4167	3690	3165	2571	2277	2088	1849	1766	1696	1586	1502	1434	
					50000	4401	3575	3165	2716	2206	1953	1792	1586	1515	1455	1361	1289	1230	
					100000	3575	2904	2571	2206	1792	1586	1455	1289	1230	1182	1106	1047	999	
1 1/2	1.46	5930	3410	2330	5000	6697	6697	6697	6263	5087	4505	4132	3659	3494	3356	3139	2972	—	
					10000	6697	6697	5930	5087	4132	3659	3356	2972	2838	2726	2550	2414	—	
					30000	5930	4817	4265	3659	2972	2632	2414	2138	2041	1961	1834	1736	—	
					50000	5087	4132	3659	3139	2550	2258	2071	1834	1751	1682	1573	1490	—	
					100000	4132	3356	2972	2550	2071	1834	1682	1490	1422	1366	1278	1210	—	
1 5/8	1.37	6050	3470	2540	5000	6833	6833	6833	6390	5190	4596	4216	3733	3564	3424	3203	—		
					10000	6833	6833	6050	5190	4216	3733	3424	3032	2895	2781	2601	—		
					30000	6050	4914	4351	3733	3032	2685	2463	2181	2082	2000	1871	—		
					50000	5190	4216	3733	3203	2601	2303	2113	1871	1786	1716	1605	—		
					100000	4216	3424	3032	2601	2113	1871	1716	1520	1451	1394	1304	—		
1 7/8	1.65	8550	4910	2980	5000	9656	9656	8656	9031	7335	6495	5958	5276	5037	4839	—			
					10000	9656	9656	8550	7335	5958	5276	4839	4285	4091	3931	—			
					30000	8550	6945	6149	5276	4285	3794	3481	3082	2943	2827	—			
					50000	7335	5958	5276	4526	3676	3255	2986	2644	2525	2425	—			
					100000	5958	4839	4285	3676	2986	2644	2425	2148	2051	1970	—			
2 3/16	1.51	9090	5220	3470	5000	10266	10266	10266	9601	7798	6905	6334	5609	5355	5145	—			
					10000	10266	10266	9090	7798	6334	5609	5145	4556	4350	4179	—			
					30000	9090	7383	6538	5609	4556	4034	3700	3277	3129	3006	—			
					50000	7798	6334	5609	4812	3908	3461	3175	2811	2684	2579	—			
					100000	6334	5145	4556	3908	3175	2811	2579	2283	2180	2095	—			
2 1/4	1.45	9290	5340	3670	5000	10492	10492	10492	9812	7970	7057	6474	5732	5473	—				
					10000	10492	10492	9290	7970	6474	5732	5258	4656	4446	—				
					30000	9290	7546	6682	5732	4656	4123	3782	3349	3197	—				
					50000	7970	6474	5732	4918	3994	3537	3245	2873	2743	—				
					100000	6474	5258	4656	3994	3245	2873	2635	2334	2228	—				
2 11/16	1.30	9600	5510	4260	5000	10842	10842	10842	10140	8236	7293	6690	5924	—					
					10000	10842	10842	9600	8236	6690	5924	5434	4811	—					
					30000	9600	7798	6905	5924	4811	4260	3908	3460	—					
					50000	8236	6690	5924	5082	4128	3655	3353	2969	—					
					100000	6690	5434	4811	4128	3353	2969	2723	2411	—					
3	1.31	14500	8330	6340	5000	16376	16376	16376	15315	12440	11015	10104	—						
					10000	16376	16376	14500	12440	10104	8947	8207	—						
					30000	14500	11778	10429	8947	7267	6435	5903	—						
					50000	12440	10104	8947	7676	6235	5521	5064	—						
					100000	10104	8207	7267	6235	5064	4484	4113	—						
3 7/16	1.19	15300	8790	7410	5000	17279	17279	17279	16160	13126	11623	10662	—						
					10000	17279	17279	15300	13126	10662	9441	8660	—						
					30000	15300	12427	11004	9441	7668	6790	6228	—						
					50000	13126	10104	8941	8099	6579	5825	5344	—						
					100000	10662	8207	7668	6579	5344	4732	4340	—						
3 15/16	1.45	18400	10600	7270	5000	20780	20780	20780	19434	15786	13978	12822	—						
					10000	20780	20780	18400	15786	12822	11353	10415	—						
					30000	18400	14945	13234	11353	9222	8166	7490	—						
					50000	15786	12822	11353	9740	7912	7005	6426	—						
					100000	12822	10415	9222	7912	6426	5690	5220	—						
4 7/16	1.91	25200	14500	7550	5000	28460	28460	28460	26617	21620	19143	17561	—						
					10000	28460	28460	25200	21620	17561	15549	14264	—						
					30000	25200	20469	18124	15549	12630	11183	10259	—						
					50000	21620	17561	15549	13340	10835	9594	8801	—						
					100000	17561	14264	12630	10835	8801	7793	7149	—						
4 15/16	1.82	26600	15300	8390	5000	30041	30041	30041	28095	22821	20207	—							
					10000	30041	30041	26600	22821	18536	16413	—							
					30000	26600	21606	19131	16413	13332	11805	—							
					50000	22821	18536	16413	14081	11437	10127	—							
					100000	18536	15056	13332	11437	9290	8226	—							



Tapered Roller Bearings

Tapered Roller Bearing 920 and 970 Series

This chart displays the Browning 920 and 970 Series Tapered Roller Bearing's load capacity for a given L10 life, speed and shaft size. Values in the table represent loads at ideal conditions. The shaded areas indicate the maximum speed for the 970 series only. For combined load determination, see **THE BEARING SELECTION SECTION**, page 268. Areas designated by “-” exceed maximum speed value.

Match Bore Size

SIZE	"K" FACTOR	2 ROW RATING	1 ROW RATING	THRUST RATING*	HOURS	REVOLUTIONS PER MINUTE													
						50	100	150	250	500	750	1000	1500	1750	2000	2500	3000	3500	4000
1 3/16 1 1/4	1.23	2975	1710	1390	5000	3360	3360	3360	3142	2552	2260	2073	1836	1753	1684	1575	1491	1424	1368
					10000	3360	3360	2975	2552	2073	1836	1491	1424	1368	1279	1211	1156	1111	
					30000	2975	2416	2140	1836	1491	1320	1211	1072	1024	984	920	871	832	799
					50000	2552	2073	1836	1575	1279	1133	1039	920	878	844	789	747	714	685
					100000	2073	1684	1491	1279	1039	920	844	747	714	685	641	607	580	556
1 3/8 1 7/16	1.31	4760	2740	2080	5000	5376	5376	5376	5028	4084	3616	3317	2937	2804	2694	2520	2386	2278	2278
					10000	5376	5376	4760	4084	3317	2937	2694	2386	2278	2188	2047	1938	1850	
					30000	4760	3866	3424	2937	2386	2112	1938	1716	1638	1574	1472	1394	1331	
					50000	4084	3317	2937	2520	2047	1812	1662	1472	1406	1350	1263	1196	1142	
					100000	3317	26741	2386	2047	1662	1472	1350	1196	1142	1097	1026	971	927	
1 1/2 1 11/16	1.36	6140	3530	2600	5000	6934	6934	6934	6485	5268	4664	4279	3789	3617	3475	3250	3077	—	—
					10000	6934	6934	6140	5268	4279	3789	3475	3077	2938	2823	2640	2500	—	—
					30000	6140	4987	4416	3789	3077	2725	2500	2213	2113	2030	1899	1798	—	—
					50000	5268	4279	3789	3250	2640	2338	2144	1899	1813	1742	1629	1542	—	—
					100000	4279	3475	3077	2640	2144	1899	1742	1542	1473	1415	1323	1253	—	—
1 3/4 1 15/16 2	1.83	8070	4640	2540	5000	9114	9114	9114	8524	6923	6130	5624	4979	4754	4568	4272	—	—	—
					10000	9114	9114	8070	6923	5624	4979	4568	4045	3862	3710	3470	—	—	—
					30000	8070	6555	5804	4979	4045	3581	3285	2909	2777	2668	2496	—	—	—
					50000	6923	5624	4979	4272	3470	3072	2818	2496	2383	2289	2141	—	—	—
					100000	5624	4568	4045	3470	2818	2496	2289	2027	1935	1859	1739	—	—	—
2 3/16	1.65	8570	4910	2980	5000	9679	9679	9679	9052	7352	6510	5972	5288	5049	4851	4537	—	—	—
					10000	9679	9679	8570	7352	5972	5288	4851	4295	4101	3940	3685	—	—	—
					30000	8570	6961	6164	5288	4295	3803	3489	3089	2950	2834	2650	—	—	—
					50000	7352	5972	5288	4537	3685	3263	2993	2650	2530	2431	2274	—	—	—
					100000	5972	4851	4295	3685	2993	2650	2431	2153	2055	1975	1847	—	—	—
2 1/4 2 7/16 2 1/2	1.51	9030	5220	3470	5000	10198	10198	10198	9538	7747	6860	6293	5572	5320	5111	—	—	—	—
					10000	10198	10198	9030	7747	6293	5572	5111	4526	4321	4152	—	—	—	—
					30000	9030	7335	6495	5572	4526	4007	3676	3255	3108	2986	—	—	—	—
					50000	7747	6293	5572	4780	3883	3438	3154	2793	2666	2562	—	—	—	—
					100000	6293	5111	4526	3883	3154	2793	2562	2268	2166	2081	—	—	—	—
2 11/16 2 15/16 3	1.30	9630	5510	4260	5000	10876	10876	10876	10171	8262	7316	6711	5942	5674	—	—	—	—	
					10000	10876	10876	9630	8262	6711	5942	5451	4826	4608	—	—	—	—	
					30000	9630	7822	6926	5942	4826	4274	3920	3471	3314	—	—	—	—	
					50000	8262	6711	5942	5098	4141	3666	3363	2978	2843	—	—	—	—	
					100000	6711	5451	4826	4141	3363	2978	2732	2419	2310	—	—	—	—	
3 3/16 3 7/16 3 1/2	1.19	15320	8790	7410	5000	17302	17302	17302	16181	13143	11638	10676	9453	—	—	—	—	—	
					10000	17302	17302	15320	13143	10676	9453	8671	7678	—	—	—	—		
					30000	15320	12444	11018	9453	7678	6799	6273	5522	—	—	—	—		
					50000	13143	10676	9453	8110	6587	5833	5351	4738	—	—	—	—		
					100000	10676	8671	7678	6587	5351	4738	4346	3848	—	—	—	—		
3 15/16 4	1.23	20980	12100	9800	5000	23694	23694	23694	22159	17999	15938	14620	12945	—	—	—	—	—	
					10000	23694	23694	20980	17999	14620	12945	11875	10515	—	—	—	—		
					30000	20980	17041	15089	12945	10515	9311	8411	7563	—	—	—	—		
					50000	17999	14620	12945	11106	9021	7988	7327	6488	—	—	—	—		
					100000	14620	11875	10515	9021	7327	6488	5952	5270	—	—	—	—		
4 7/16 4 1/2	1.13	25750	14800	13100	5000	29081	29081	29081	27198	22091	19561	17944	—	—	—	—	—		
					10000	29081	29081	25750	22091	17944	15889	14575	—	—	—	—			
					30000	25750	20915	18520	15889	12906	11427	10483	—	—	—	—			
					50000	22091	17944	15889	13631	11072	9804	8993	—	—	—	—			
					100000	17944	14575	12906	11072	8993	7963	7305	—	—	—	—			
4 15/16 5	1.27	35520	20400	16000	5000	40114	40114	40114	37517	30473	26983	24752	—	—	—	—	—		
					10000	40114	40114	35520	30473	24752	21917	20105	—	—	—	—			
					30000	35520	28851	25547	21917	17802	15763	14460	—	—	—	—			
					50000	30473	24752	21917	18803	15273	13524	12405	—	—	—	—			
					100000	24752	20105	17802	15273	12405	10985	10076	—	—	—	—			

Tapered Roller Bearings

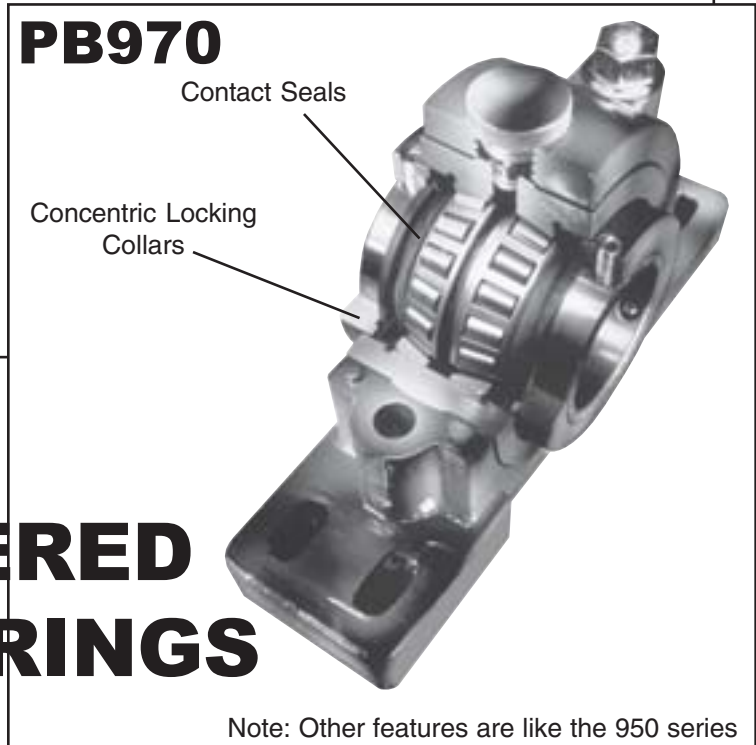
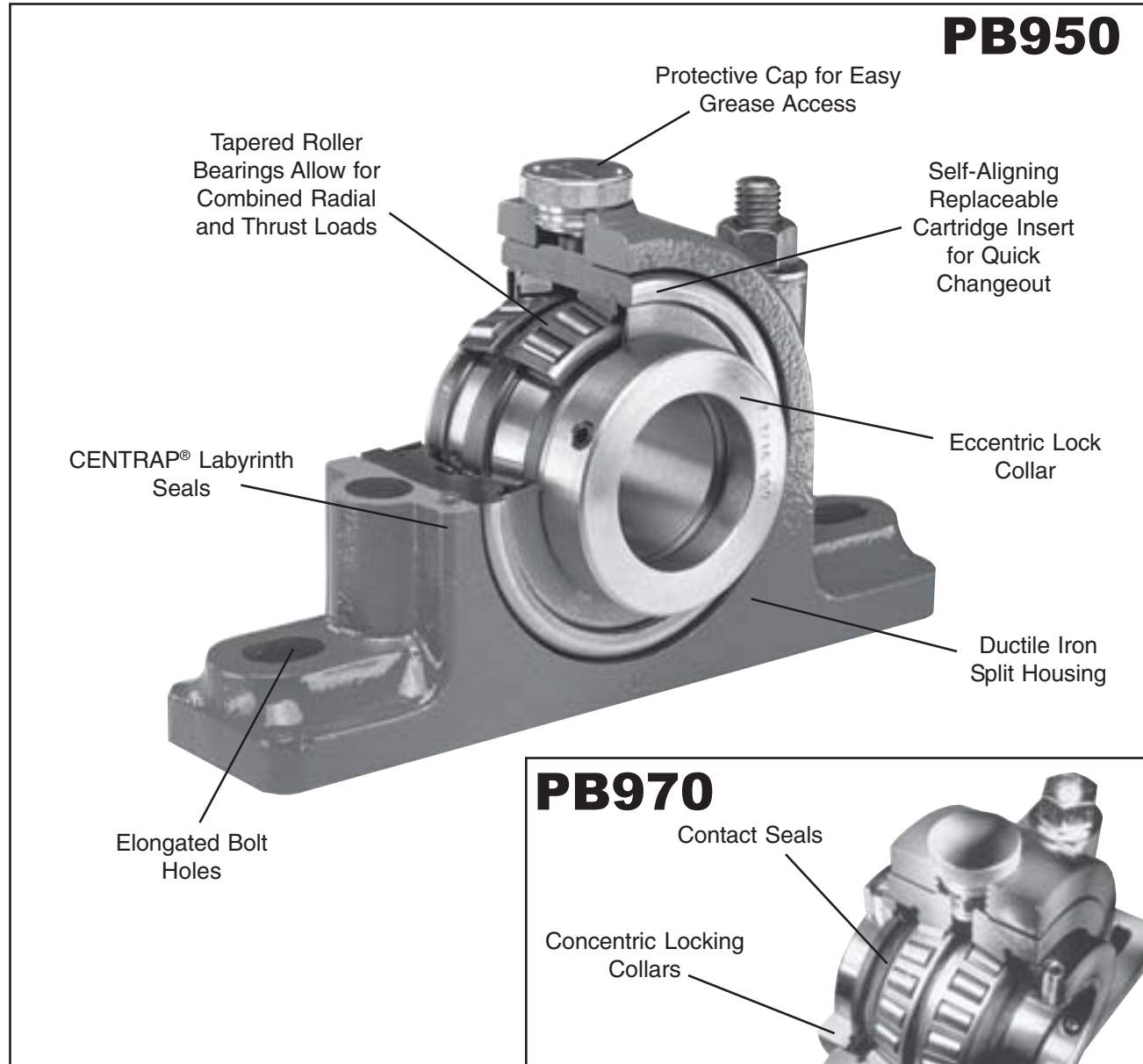

BROWNING 950/970 TAPERED ROLLER BEARINGS FEATURES/BENEFITS

LOCKING

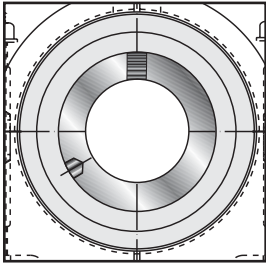

950 ECCENTRIC LOCK-

Browning 950 Series roller bearings have an eccentric locking collar that mates with the inner race for improved shaft hold. One end of the inner race is machined to a cam form and the mating lock collar has an off center counterbore. The wedge

action of the collar on the inner race secures the inner race to the shaft. This locking method tends to tighten and grip the shaft and not leave burrs as with setscrew collars. **NOTE: Eccentric collars are not recommended for reversing applications.**

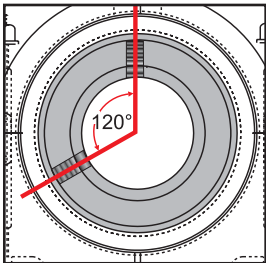

970 SETSCREW LOCK-

This locking device has two rugged lock collars with two setscrews to anchor the bearing to the inner race. The elastic deflection of the collar serves to help retain the bearing hold to the shaft. Double locking collars with setscrews at 120°

provide improved holding power and shaft lock, especially in applications with vibration or unidirectional loads. Double extended inner races provide improved shaft support – the load is distributed evenly over a wide area. Browning lock collars are black oxide coated for corrosion resistance.

SEALS

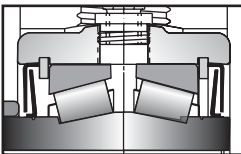

950 SEALS - CENTRAP®

Labyrinth seals contain an angled flinger that rotates with the shaft, creating a centrifugal force to help keep out contamination. Excess

grease purges from the seal to help remove contaminants caught in the lubricant and prevent seal damage from over lubrication. This non-contact labyrinth design reduces drag, saves energy and normally cannot be blown by over greasing.

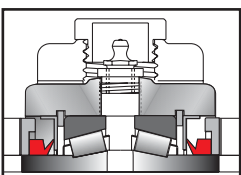

970 SEALS -

The rubber contact face seal is designed to retain lubricant and help exclude contaminants. The seal is designed with a long flexible face that seals axially against the counterface. The

contact seal is self purging. It retains low torque characteristics and rotates with the shaft to help reduce contaminant build-up on the seal. Its low friction reduces heat generation and wear.

See page 156 for trademark acknowledgments.

BROWNING TAPERED ROLLER BEARINGS 950/970 SERIES FEATURES/BENEFITS

HOUSINGS

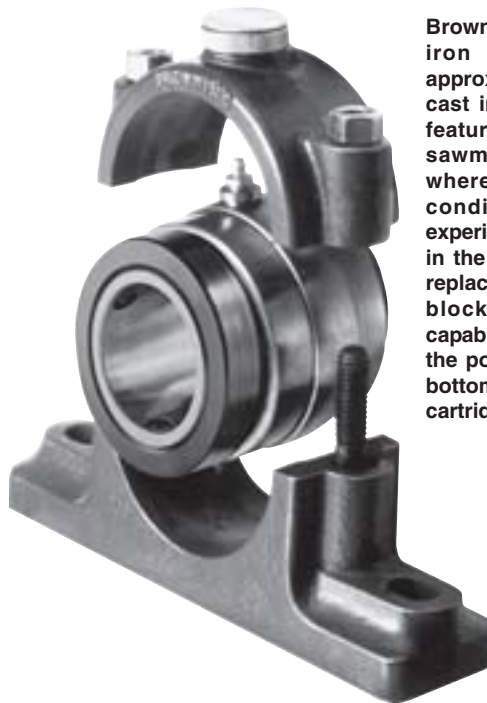

Browning 950/970 Series ductile iron split housings are approximately twice as strong as cast iron. This is an important feature in applications such as sawmills, aggregate and steel where heavy loads and shock conditions are normally experienced. Elongated bolt holes in the housing base permit easy replacement of competitive pillow blocks and more adjustment capability. Guide pins also reduce the possibility of having top and bottom mismatch when replacing cartridge inserts.

TABLE OF CONTENTS

PB950 Pillow Blocks	118
FB950 Flange Blocks	119
C950 Cartridges	120
950 Ratings	121
950 Interchange Tables ...	166

PB970 Pillow Blocks	122
FB970 Flange Blocks	123
C970 Cartridges	124
970 Ratings	125
970 Interchange Tables ...	166
900/E920	102
1000/1100	126
22200/22500	140

Tapered Roller Bearings

PB950

Lock: Eccentric
Seal: CENTRAP[®] Labyrinth
Housing: Ductile Iron
Temperatures: -20°F to 200°F
Self Aligning: ±1 1/2°
Fitting: 1/8" NPT
Bearing Insert: Tapered Roller
 (C950 Cartridge)

P PILLOW
B BLOCK

9 950
5 ECCENTRIC LOCK
0 TAPERED ROLLER BEARING

Dimensional Interchange with Type K Units



Load Rating Tables: Page 121
Interchange Tables: Page 166

Expansion and Non-Expansion

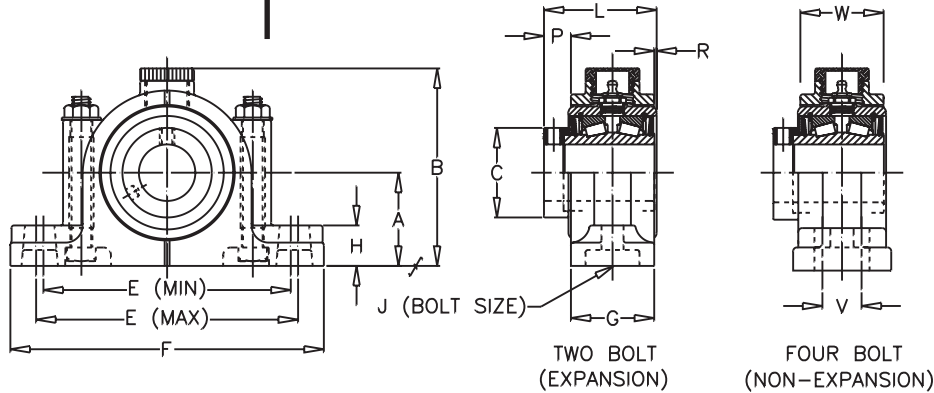

SHAFT DIA. IN.	Dimensions In Inches														UNIT WT.
	A	B	C	E		F	G	H	J	L	P	R	V	W	
				MIN.	MAX.										
TWO BOLT BASE															
1 7/16	2 3/8	5 1/32	2 3/16	6 5/16	6 11/16	8	2 1/8	1 1/32	1/2	2 7/8	11/16	1/16	-	-	11.0
1 1/2															
1 5/8	2 5/8	5 13/32	2 1/2	7 1/16	7 11/16	9	2 1/4	1 5/32	1/2	2 15/16	5/8	1/8	-	-	13.5
1 11/16															
1 3/4															
1 7/8															
1 15/16	2 7/8	6 1/16	3	7 7/8	8 1/2	10	2 3/8	1 9/32	5/8	3 5/32	3/4	3/32	-	-	18.4
2															
2 1/8															
2 3/16	3	6 13/32	3 3/8	8 1/2	9 1/4	10 7/8	2 1/2	1 9/32	5/8	3 7/32	23/64	3/32	-	-	21.7
2 1/4															
2 7/16	3 1/4	6 25/32	3 3/8	9 3/64	10 5/16	12	2 1/2	1 13/32	5/8	3 21/64	51/64	5/64	-	-	26.0
2 1/2															
2 11/16															
2 3/4	3 3/4	7 21/32	4	10 3/16	11 9/16	13 3/8	2 5/8	1 13/32	3/4	3 15/32	27/32	3/32	-	-	33.4
2 15/16															
3															
3 3/16	3 3/4	7 15/16	4 1/4	10 11/16	12 3/64	13 7/8	3 1/8	1 13/32	3/4	3 31/32	27/32	3/32	-	-	41.7
3 7/16															
3 1/2	4 1/2	9 5/32	4 11/16	12 1/2	13 7/8	16	3 1/8	1 29/32	7/8	4 5/64	61/64	5/64	-	-	57.0
FOUR BOLT BASE															
3 15/16	5	10 1/32	5 1/4	13 3/16	14 13/16	16 3/4	4 1/8	2 1/32	13/16	4 29/32	1 1/32	5/32	2	3 7/8	83.5
4															
4 7/16	5 3/4	11 13/32	6 1/8	14 7/16	16 5/16	18 1/4	4 3/8	2 1/4	3/4	5 1/4	1 1/8	1/16	2 1/4	4 1/8	110.0
4 1/2															
4 15/16	6 1/4	12 9/32	6 5/8	16 1/8	18 1/8	20 3/8	4 7/8	2 1/2	7/8	5 15/32	1 7/32	3/32	2 1/2	4 1/4	141.0
5															

Non-expansion Pillow Block Part Numbers are specified by "PB950NE" and bore size: Example, "PB950NEx2 7/16".
 Expansion Pillow Block Numbers are specified by "PB950E" and bore size: Example, "PB950Ex2 7/16".
 Bearings with eccentric locking collars are not recommended for reversing applications.

Tapered Roller Bearings

FB950



FLANGE F
BLOCK B

950 9
ECCENTRIC LOCK 5
TAPERED ROLLER BEARING 0

**Dimensional Interchange
with Type K Units**

Lock: Eccentric
Seal: CENTRAP® Labyrinth
Housing: Ductile Iron
Temperatures: -20°F to 200°F
Self Aligning: ±1 1/2°
Fitting: 1/8" NPT
Bearing Insert: Tapered Roller
(C950 Cartridge)

Load Rating Tables: Page 121
Interchange Tables: Page 166

Expansion and Non-Expansion

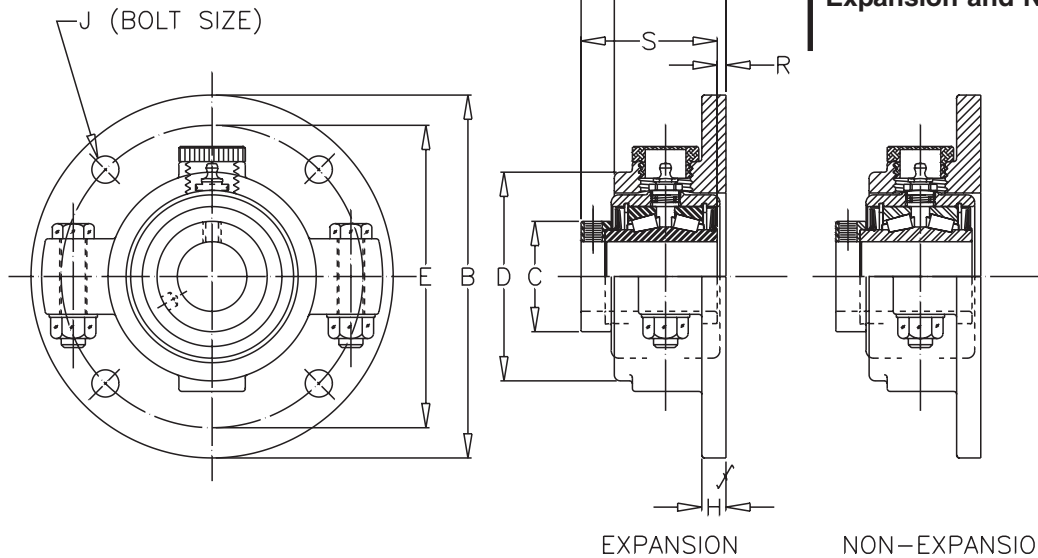

SHAFT DIA. IN.	Dimensions in Inches										UNIT WT.
	B	C	D	E	H	J	L	M	R	S	
1 7/16	7 1/2	2 3/16	4 5/16	6 1/4	1/2	1/2	3	2 5/16	3/16	2 13/16	13.3
1 1/2											
1 5/8											
1 11/16	8	2 1/2	4 5/8	6 3/4	1/2	1/2	3 1/16	2 7/16	1/4	2 13/16	16.1
1 3/4											
1 7/8											
1 15/16	8 7/8	3	5 1/2	7 1/2	9/16	5/8	3 5/16	2 9/16	1/4	3 1/16	20.8
2											
2 1/8											
2 3/16	9 3/8	3 3/8	6	8	9/16	5/8	3 13/32	2 11/16	9/32	3 1/8	25.1
2 1/4											
2 7/16	9 7/8	3 3/8	6 5/16	8 1/2	5/8	5/8	3 35/64	2 3/4	19/64	3 1/4	29.4
2 1/2											
2 11/16											
2 3/4	11 1/4	4	7 1/8	9 3/4	11/16	3/4	3 25/32	2 15/16	13/32	3 3/8	38.2
2 15/16											
3											
3 3/16	11 1/4	4 1/4	7 5/8	9 3/4	11/16	3/4	4 9/32	3 7/16	13/32	3 7/8	45.8
3 7/16											
3 1/2	13 1/4	4 11/16	8 5/8	11 1/2	3/4	7/8	4 25/64	3 7/16	13/32	4	61.0
3 15/16											
4	15 1/4	5 1/4	9 3/8	13	13/16	1 1/32	5 9/32	4 1/4	17/32	4 3/4	98.0
4 7/16											
4 1/2	17	6 1/8	10 5/8	15	1	1 1/32	5 5/8	4 1/2	7/16	5 3/16	134.0
4 15/16											
5	18 1/8	6 5/8	11 3/8	16	1 1/8	1 1/8	5 27/32	4 5/8	15/32	5 3/8	157.0

Non-Expansion Pillow Block Part Numbers are specified by "FB950NE" and bore size: Example, **FB950NEx 2 7/16"**.

Expansion Pillow Block Part Numbers are specified by "FB950E" and bore size: Example, **FB950Ex 2 7/16"**.

Bearings with Eccentric Locking Collars are not recommended for reversing applications.

See page 156 for trademark acknowledgments.



C950

Lock: Eccentric
Seal: CENTRAP® Labyrinth
Temperatures: -20°F to 200°F
Self Aligning: ±1 1/2°
Fitting: 1/8" NPT
Bearing Insert: Tapered Roller

Load Rating Tables: Page 121
Interchange Tables: Page 166

C CARTRIDGE

9 950
5 ECCENTRIC LOCK
0 TAPERED ROLLER BEARING

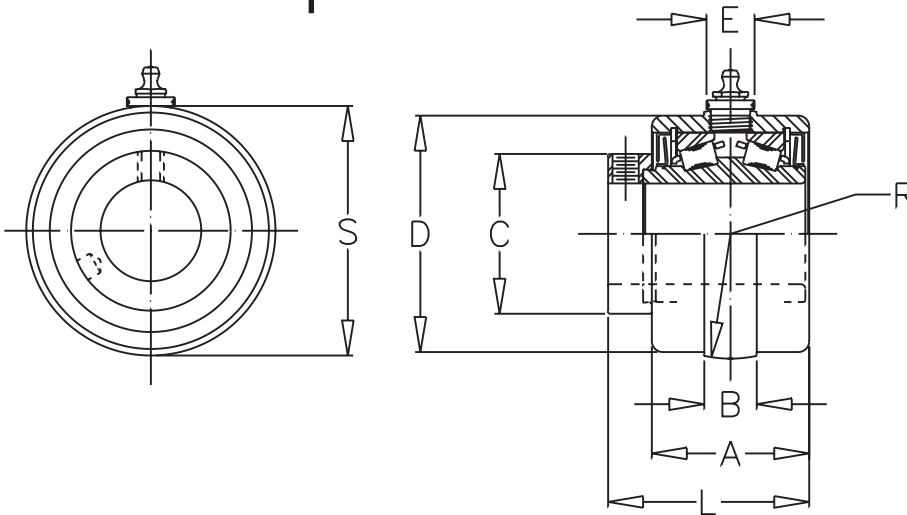

SHAFT DIA. IN.	Dimensions In Inches								UNIT WT.
	A	B	C	D	E	L	R	S	
1 7/16 1 1/2	2 1/4	3/4	2 3/16	3 3/8	11/16	2 7/8	1 25/32	3 9/16	4.2
1 5/8 1 11/16 1 3/4	2 3/8	3/4	2 1/2	3 5/8	11/16	2 15/16	1 29/32	3 13/16	4.8
1 7/8 1 15/16 2 2 1/8	2 7/16	1	3	4 13/32	11/16	3 5/32	2 5/16	4 5/8	7.5
2 3/16 2 1/4 2 7/16 2 1/2	2 1/2	1	3 3/8	4 27/32	11/16	3 7/32	2 17/32	5 1/16	19.4
2 11/16 2 3/4 2 15/16	2 5/8	1 1/4	3 7/16	5 5/8	11/16	3 15/32	2 31/32	5 15/16	13.6
3 3 3/16 3 7/16 3 1/2	3 1/8	1 1/4	4 1/4	6 1/8	11/16	3 31/32	3 7/32	6 7/16	18.3
3 15/16 4 4 7/16 4 1/2 4 15/16 5	3 7/8	1 3/8	5 1/4	7 1/2	11/16	4 29/32	3 29/32	7 13/16	32.8
	4 1/8	1 5/8	6 1/8	8 1/2	11/16	5 17/64	4 7/16	8 7/8	47.0
	4 1/4	1 3/4	6 5/8	9	11/16	5 15/32	4 11/16	9 3/8	51.0

Replacement Cartridge Part Numbers are specified by "C950" and bore size: Example, **C950x 2 7/16"**.

Browning C950 Replacement Cartridges Fit both Expansion and Non-Expansion Pillow Blocks and Flange Blocks.

Bearings with Eccentric Locking Collars are not recommended for reversing applications.



Tapered Roller Bearings

Tapered Roller Bearing 900 and 950 Series

This chart displays the Browning 900 and 950 Series Tapered Roller Bearing's load capacity for a given L10 life, speed and shaft size. Values in the table represent loads at ideal conditions. The shaded areas indicate the maximum speed for the 950 series only. Select 950 Series where aligning capability is required. For combined load determination, see **THE BEARING SELECTION SECTION**, page 268. Areas designated by “-” exceed maximum speed value.

Match Bore Size

SIZE	"K" FACTOR	2 ROW RATING	1 ROW RATING	THRUST RATING*	L10 HOURS	REVOLUTIONS PER MINUTE												
						50	100	150	250	500	750	1000	1500	1750	2000	2500	3000	3500
1	1.42	3700	2130	1500	5000	4179	4179	4179	3908	3174	2811	2578	2283	2180	2094	1959	1854	1771
					10000	4179	4179	3700	3174	2578	2283	2094	1854	1771	1701	1591	1506	1438
					30000	3700	3005	2611	2283	1854	1642	1506	1334	1273	1223	1144	1083	1034
					50000	3174	2578	2283	1959	1591	1409	1292	1144	1093	1050	982	929	887
					100000	2578	2094	1854	1591	1292	1144	1050	929	887	853	797	755	721
1 3/16 1 1/4 1 3/8	1.53	5130	2950	1930	5000	5794	5794	5794	5418	4401	3897	3575	3165	3022	2904	2716	2571	2455
					10000	5794	5794	5130	4401	3575	3165	2904	2571	2455	2358	2206	2088	1944
					30000	5130	4167	3690	3165	2571	2277	2088	1849	1766	1696	1586	1502	1434
					50000	4401	3575	3165	2716	2206	1953	1792	1586	1515	1455	1361	1289	1230
					100000	3575	2904	2571	2206	1792	1586	1455	1289	1230	1182	1106	1047	999
1 7/16 1 1/2	1.46	5930	3410	2330	5000	6697	6697	6697	6263	5087	4505	4132	3659	3494	3356	3139	2972	—
					10000	6697	6697	5930	5087	4132	3659	3356	2972	2838	2726	2550	2414	—
					30000	5930	4817	4265	3659	2972	2632	2414	2138	2041	1961	1834	1736	—
					50000	5087	4132	3659	3139	2550	2258	2071	1834	1751	1682	1573	1490	—
					100000	4132	3356	2972	2550	2071	1834	1682	1490	1422	1366	1278	1210	—
1 5/8 1 11/16 1 3/4	1.37	6050	3470	2540	5000	6833	6833	6833	6390	5190	4596	4216	3733	3564	3424	3203	—	—
					10000	6833	6833	6050	5190	4216	3733	3424	3032	2895	2781	2601	—	—
					30000	6050	4914	4351	3733	3032	2685	2463	2181	2082	2000	1871	—	—
					50000	5190	4216	3733	3203	2601	2303	2113	1871	1786	1716	1605	—	—
					100000	4216	3424	3032	2601	2113	1871	1716	1520	1451	1394	1304	—	—
1 7/8 1 15/16 2 2 1/8	1.65	8550	4910	2980	5000	9656	9656	8656	9031	7335	6495	5958	5276	5037	4839	—	—	—
					10000	9656	9656	8550	7335	5958	5276	4839	4285	4091	3931	—	—	—
					30000	8550	6945	6149	5276	4285	3794	3481	3082	2943	2827	—	—	—
					50000	7335	5958	5276	4526	3676	3255	2986	2644	2525	2425	—	—	—
					100000	5958	4839	4285	3676	2986	2644	2425	2148	2051	1970	—	—	—
2 3/16	1.51	9090	5220	3470	5000	10266	10266	10266	9601	7798	6905	6334	5609	5355	5145	—	—	—
					10000	10266	10266	9090	7798	6334	5609	5145	4556	4350	4179	—	—	—
					30000	9090	7383	6538	5609	4556	4034	3700	3277	3129	3006	—	—	—
					50000	7798	6334	5609	4812	3908	3461	3175	2811	2684	2579	—	—	—
					100000	6334	5145	4556	3908	3175	2811	2579	2283	2180	2095	—	—	—
2 1/4 2 7/16 2 1/2	1.45	9290	5340	3670	5000	10492	10492	10492	9812	7970	7057	6474	5732	5473	—	—	—	—
					10000	10492	10492	9290	7970	6474	5732	5258	4656	4446	—	—	—	—
					30000	9290	7546	6682	5732	4656	4123	3782	3349	3197	—	—	—	—
					50000	7970	6474	5732	4918	3994	3537	3245	2873	2743	—	—	—	—
					100000	6474	5258	4656	3994	3245	2873	2635	2334	2228	—	—	—	—
2 11/16 2 3/4 2 15/16	1.30	9600	5510	4260	5000	10842	10842	10842	10140	8236	7293	6690	5924	—	—	—	—	—
					10000	10842	10842	9600	8236	6690	5924	5434	4811	—	—	—	—	—
					30000	9600	7798	6905	5924	4811	4260	3908	3460	—	—	—	—	—
					50000	8236	6690	5924	5082	4128	3655	3353	2969	—	—	—	—	—
					100000	6690	5434	4811	4128	3353	2969	2723	2411	—	—	—	—	—
3 3 3/16	1.31	14500	8330	6340	5000	16376	16376	16376	15315	12440	11015	10104	—	—	—	—	—	—
					10000	16376	16378	14500	12440	10104	8947	8207	—	—	—	—	—	—
					30000	14500	11778	10429	8947	7267	6435	5903	—	—	—	—	—	—
					50000	12440	10104	8947	7676	6235	5521	5064	—	—	—	—	—	—
					100000	10104	8207	7267	6235	5064	4484	4113	—	—	—	—	—	—
3 7/16 3 1/2	1.19	15300	8790	7410	5000	17279	17279	17279	16160	13126	11623	10662	—	—	—	—	—	—
					10000	17279	17279	15300	13126	10662	9441	8660	—	—	—	—	—	—
					30000	15300	12427	11004	9441	7668	6790	6228	—	—	—	—	—	—
					50000	13126	10104	9441	8099	6579	5825	5344	—	—	—	—	—	—
					100000	10662	8207	7668	6579	5344	4732	4340	—	—	—	—	—	—
3 15/16 4	1.45	18400	10600	7270	5000	20780	20780	20780	19434	15786	13978	12822	—	—	—	—	—	—
					10000	20780	20780	18400	15786	12822	11353	10415	—	—	—	—	—	—
					30000	18400	14945	13234	11353	9222	8166	7490	—	—	—	—	—	—
					50000	15786	12822	11353	9740	7912	7005	6426	—	—	—	—	—	—
					100000	12822	10415	9222	7912	6426	5690	5220	—	—	—	—	—	—
4 7/16 4 1/2	1.91	25200	14500	7550	5000	28460	28460	28460	26617	21620	19143	17561	—	—	—	—	—	—
					10000	28460	28460	25200	21620	17561	15549	14264	—	—	—	—	—	—
					30000	25200	20469	18124	15549	12630	11183	10259	—	—	—	—	—	—
					50000	21620	17561	15549	13340	10835	9594	8801	—	—	—	—	—	—
					100000	17561	14264	12630	10835	8801	7793	7149	—	—	—	—	—	—
4 15/16 5	1.82	26600	15300	8390	5000	30041	30041	30041	28095	22821	20207	—	—	—	—	—	—	—
					10000	30041	30041	26600	22821	18536	16413	—	—	—	—	—	—	—
					30000	26600	21606	19131	16413	13332	11805	—	—	—	—	—	—	—
					50000	22821	18536	16413	14081	11437	10127	—	—	—	—	—	—	—
					100000	18536	15056	13332	11437	9290	8226	—	—	—	—	—	—	—

PB970

Lock: Set Screw
 Seal: Contact
 Housing: Ductile Iron
 Temperatures: - 20° to 200°F
 Self Aligning: ±1 1/2°
 Fitting: 1/8" NPT
 Bolt Holes: Elongated
 Bearing Insert: Tapered Roller
 (C970 Cartridge Insert)

P PILLOW
B BLOCK

9 970
7 SET SCREW LOCK
0 TAPERED ROLLER BEARING

Dimensional Interchange with (DI) Units



Load Rating Tables: Page 125
 Interchange Tables: Page 166

Expansion and Non-Expansion

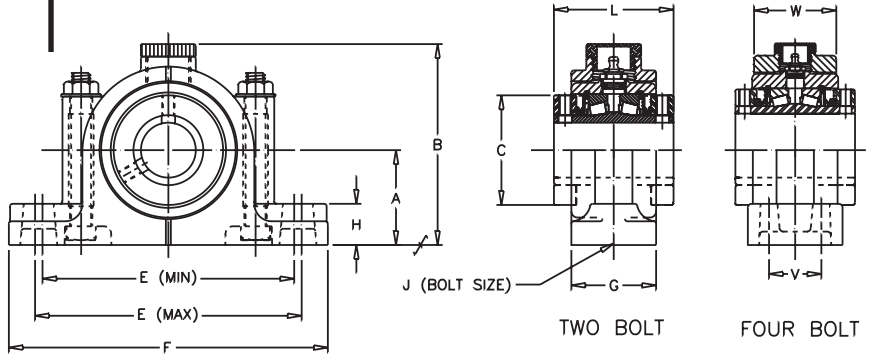

SHAFT DIA. IN.	Dimensions In Inches												UNIT WT.
	A	B	C	E		F	G	H	J	L	V	W	
				MIN.	MAX.								
TWO BOLT BASE													
1 3/8	2 3/8	5 1/32	2 3/4	6 5/16	6 11/16	8	2 1/8	1 1/32	1/2	3	-	-	11.0
1 7/16	2 5/8	5 13/32	3 3/16	7 1/16	7 11/16	9	2 1/4	1 5/32	1/2	3 7/16	-	-	13.5
1 1/2	2 5/8	5 13/32	3 3/16	7 1/16	7 11/16	9	2 1/4	1 5/32	1/2	3 7/16	-	-	13.5
1 11/16	2 5/8	5 13/32	3 3/16	7 1/16	7 11/16	9	2 1/4	1 5/32	1/2	3 7/16	-	-	13.5
1 3/4	2 7/8	6 1/16	3 7/16	7 7/8	8 1/2	10	2 3/8	1 9/32	5/8	3 1/2	-	-	18.4
1 15/16	2 7/8	6 1/16	3 7/16	7 7/8	8 1/2	10	2 3/8	1 9/32	5/8	3 1/2	-	-	18.4
2	3	6 13/32	3 3/4	8 1/2	9 1/4	10 7/8	2 1/2	1 9/32	5/8	3 3/4	-	-	21.7
2 3/16	3	6 13/32	3 3/4	8 1/2	9 1/4	10 7/8	2 1/2	1 9/32	5/8	3 3/4	-	-	21.7
2 1/4	3 1/4	6 25/32	4 1/16	9 1/16	10 5/16	12	2 1/2	1 13/32	5/8	4	-	-	25.3
2 7/16	3 1/4	6 25/32	4 1/16	9 1/16	10 5/16	12	2 1/2	1 13/32	5/8	4	-	-	25.3
2 1/2	3 1/4	6 25/32	4 1/16	9 1/16	10 5/16	12	2 1/2	1 13/32	5/8	4	-	-	25.3
2 11/16	3 3/4	7 21/32	4 23/32	10 3/16	11 9/16	13 3/8	2 5/8	1 13/32	3/4	4 33/64	-	-	32.5
2 15/16	3 3/4	7 21/32	4 23/32	10 3/16	11 9/16	13 3/8	2 5/8	1 13/32	3/4	4 33/64	-	-	32.5
3	4 1/2	9 5/32	5 7/16	12 1/2	13 7/8	16	3 1/8	1 29/32	7/8	5 1/64	-	-	57.0
3 3/16	4 1/2	9 5/32	5 7/16	12 1/2	13 7/8	16	3 1/8	1 29/32	7/8	5 1/64	-	-	57.0
3 7/16	4 1/2	9 5/32	5 7/16	12 1/2	13 7/8	16	3 1/8	1 29/32	7/8	5 1/64	-	-	57.0
3 1/2	4 1/2	9 5/32	5 7/16	12 1/2	13 7/8	16	3 1/8	1 29/32	7/8	5 1/64	-	-	57.0
FOUR BOLT BASE													
2 1/4	3 1/4	6 13/16	4 1/16	9 1/16	10 5/16	12	3 3/8	1 15/32	1/2	4	1 3/4	2 3/4	30.0
2 7/16	3 1/4	6 13/16	4 1/16	9 1/16	10 5/16	12	3 3/8	1 15/32	1/2	4	1 3/4	2 3/4	30.0
2 1/2	3 1/4	6 13/16	4 1/16	9 1/16	10 5/16	12	3 3/8	1 15/32	1/2	4	1 3/4	2 3/4	30.0
2 11/16	3 3/4	7 11/16	4 23/32	10 3/16	11 9/16	13 1/2	3 3/4	1 31/32	5/8	4 33/64	1 7/8	3 1/8	38.0
2 15/16	3 3/4	7 11/16	4 23/32	10 3/16	11 9/16	13 1/2	3 3/4	1 31/32	5/8	4 33/64	1 7/8	3 1/8	38.0
3	4 1/2	9 5/32	5 7/16	12 1/2	13 7/8	16	4	2 7/32	3/4	5 1/64	2	3 1/2	60.0
3 3/16	4 1/2	9 5/32	5 7/16	12 1/2	13 7/8	16	4	2 7/32	3/4	5 1/64	2	3 1/2	60.0
3 7/16	4 1/2	9 5/32	5 7/16	12 1/2	13 7/8	16	4	2 7/32	3/4	5 1/64	2	3 1/2	60.0
3 1/2	4 1/2	9 5/32	5 7/16	12 1/2	13 7/8	16	4	2 7/32	3/4	5 1/64	2	3 1/2	60.0
3 15/16	5	10 1/32	5 15/16	13 3/16	14 13/16	16 3/4	4 1/8	2 1/32	3/4	6 1/4	2	3 7/8	84.0
4	5	10 1/32	5 15/16	13 3/16	14 13/16	16 3/4	4 1/8	2 1/32	3/4	6 1/4	2	3 7/8	84.0
4 7/16	5 3/4	11 13/32	6 13/32	14 7/16	16 5/16	18 1/4	4 3/8	2 1/4	3/4	6 3/4	2 1/4	4 1/8	110.0
4 1/2	5 3/4	11 13/32	6 13/32	14 7/16	16 5/16	18 1/4	4 3/8	2 1/4	3/4	6 3/4	2 1/4	4 1/8	110.0
4 15/16	6 1/4	12 3/4	7 13/32	16 1/8	18 1/8	20 3/8	4 7/8	2 1/2	7/8	7 1/4	2 1/2	4 1/4	141.0
5	6 1/4	12 3/4	7 13/32	16 1/8	18 1/8	20 3/8	4 7/8	2 1/2	7/8	7 1/4	2 1/2	4 1/4	141.0

Non-Expansion Pillow Block Part Numbers are specified by "PB970NE" and bore size: Example, **PB970NEx 2 7/16"**. Add "F" for Four Bolt Base: Example, **PB970FNEx 2 7/16"**. Expansion Pillow Block Part Numbers are specified by "PB970E" and bore size: Example, **PB970Ex 2 7/16"**. Add "F" for Four Bolt Base: Example, **PB970FEx 2 7/16"**

Tapered Roller Bearings

FB970



FLANGE F
BLOCK B

970 9

SET SCREW LOCK 7

TAPERED ROLLER BEARING 0

**Dimensional Interchange
with (DI) Units**

Lock: Set Screw
Seal: Contact
Housing: Ductile Iron
Temperatures: - 20°F to 200°F
Self Aligning: ±1 1/2°
Fitting: 1/8" NPT
Bearing Insert: Tapered Roller
(C970 Cartridge Insert)

Load Rating Tables: Page 125
Interchange Tables: Page 166

Expansion and Non-Expansion

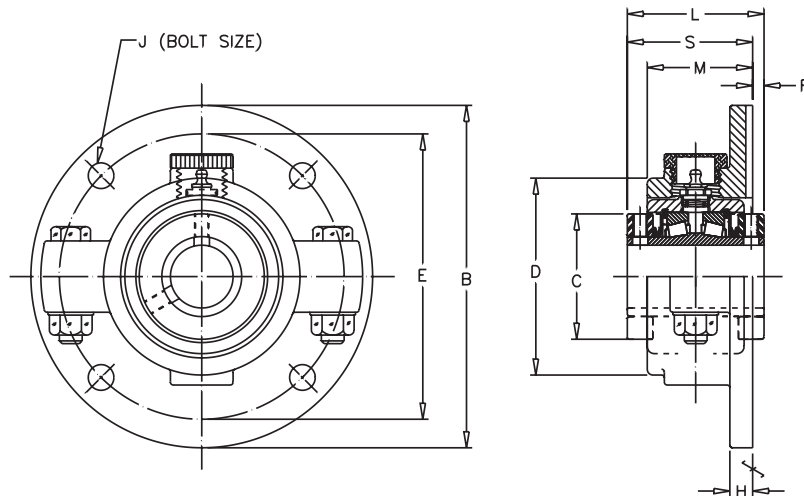

SHAFT DIA. IN.	Dimensions In Inches										UNIT WT.
	B	C	D	E	H	J	L	M	R	S	
1 3/8 1 7/16	7 1/2	2 3/4	4 5/16	6 1/4	1/2	1/2	3	2 5/16	1/4	2 3/4	14.1
1 1/2 1 11/16	8	3 3/16	4 5/8	6 3/4	1/2	1/2	3 7/16	2 7/16	25/64	3 1/32	17.0
1 3/4 1 15/16 2	8 7/8	3 7/16	5 1/2	7 1/2	9/16	5/8	3 1/2	2 9/16	3/8	3 1/8	22.2
2 3/16 2 1/4 2 7/16 2 1/2	9 3/8	3 3/4	6	8	9/16	5/8	3 3/4	2 11/16	17/32	3 7/32	26.9
2 11/16 2 15/16 3	11 1/4	4 23/32	7 1/8	9 3/4	11/16	3/4	4 33/64	2 15/16	5/8	3 7/8	40.6
3 3/16 3 7/16 3 1/2	13 1/4	5 7/16	8 5/8	11 1/2	3/4	7/8	5 1/64	3 7/16	5/8	4 3/8	65.3
3 15/16 4	15 1/4	5 15/16	9 3/8	13	13/16	1	6 1/4	4 1/4	13/16	5 7/16	104.2
4 7/16 4 1/2	17	6 13/32	10 5/8	15	1	1	6 3/4	4 1/2	15/16	5 53/64	142.9
4 15/16 5	18 1/8	7 13/32	11 3/8	16	1 1/8	1 1/8	7 1/4	4 5/8	1 1/8	6 1/8	166.7

Non-Expansion Pillow Block Part Numbers are specified by "FB970NE" and bore size: Example, **FB970NE 2 7/16"**.

Expansion Pillow Block Part Numbers are specified by "FB970E" and bore size: Example, **FB970E 2 7/16"**.

See page 156 for trademark acknowledgments.



970

Browning®

Tapered Roller Bearings

C970

Lock: Set Screw
Seal: Contact
Temperatures: - 20° to 200°F
Self Aligning: ±1 1/2°
Fitting: 1/8" NPT
Bearing Insert: Tapered Roller

Load Rating Tables: Page 125
Interchange Tables: Page 166

C CARTRIDGE

9 970

7 SET SCREW LOCK

0 TAPERED ROLLER BEARING

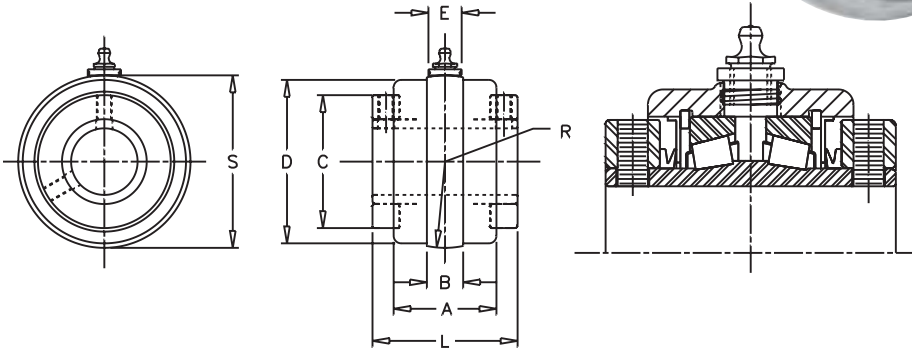

SHAFT DIA. IN.	Dimensions In Inches								UNIT WT.
	A	B	C	D	E	L	R	S	
1 3/8 1 7/16	2 1/8	3/4	2 3/4	3 3/8	11/16	3	1 25/32	3 9/16	5.0
1 1/2 1 11/16	2 3/8	3/4	3 3/16	3 5/8	11/16	3 7/16	1 29/32	3 13/16	5.7
1 3/4 1 15/16 2	2 1/2	1	3 7/16	4 13/32	11/16	3 1/2	2 5/16	4 5/8	8.9
2 3/16 2 1/4 2 7/16 2 1/2	2 5/8	1	3 3/4	4 27/32	11/16	3 3/4	2 17/32	5 1/16	11.3
2 11/16 2 15/16 3	3	1 1/4	4 23/32	5 5/8	11/16	4 33/64	2 31/32	5 15/16	14.9
3 3/16 3 7/16 3 1/2	3 5/8	1 1/4	5 7/16	6 7/8	11/16	5 1/64	3 19/32	7 3/16	27.1
3 15/16 4	4 1/2	1 3/8	5 15/16	7 1/2	11/16	6 1/4	3 29/32	7 13/16	39.0
4 7/16 4 1/2	4 5/8	1 5/8	6 13/32	8 1/2	11/16	6 3/4	4 7/16	8 7/8	55.9
4 15/16 5	5 1/8	1 3/4	7 13/32	9 11/16	11/16	7 1/4	5 3/32	10 3/16	60.7

Replacement Cartridge Part Numbers are specified by "C970" and bore size: Example, **C970x 2 7/16"**.

Browning C970 Replacement Cartridges Fit both Expansion and Non-Expansion Pillow Blocks and Flange Blocks.



Tapered Roller Bearings

Tapered Roller Bearing 920 and 970 Series

This chart displays the Browning 920 and 970 Series Tapered Roller Bearing's load capacity for a given L10 life, speed and shaft size. Values in the table represent loads at ideal conditions. The shaded areas indicate the maximum speed for the 970 series only. For combined load determination, see **THE BEARING SELECTION SECTION**, page 268. Areas designated by "-" exceed maximum speed value.

Match Bore Size

SIZE	"K" FACTOR	2 ROW RATING	1 ROW RATING	THRUST RATING*	HOURS	REVOLUTIONS PER MINUTE														
						50	100	150	250	500	750	1000	1500	1750	2000	2500	3000	3500	4000	
1 3/16 1 1/4	1.23	2975	1710	1390	5000	3360	3360	3360	3142	2552	2260	2073	1836	1753	1684	1575	1491	1424	1368	
					10000	3360	3360	2975	2552	2073	1836	1684	1491	1424	1368	1279	1211	1156	1111	
					30000	2975	2416	2140	1836	1491	1320	1211	1072	1024	984	920	871	832	799	
					50000	2552	2073	1836	1575	1279	1133	1039	920	878	844	789	747	714	685	
					100000	2073	1684	1491	1279	1039	920	844	747	714	685	641	607	580	556	
1 3/8 1 7/16	1.31	4760	2740	2080	5000	5376	5376	5376	5028	4084	3616	3317	2937	2804	2694	2520	2386	2278	—	
					10000	5376	5376	4760	4084	3317	2937	2694	2386	2278	2188	2047	1938	1850	—	
					30000	4760	3866	3424	2937	2386	2112	1938	1716	1638	1574	1472	1394	1331	—	
					50000	4084	3317	2937	2520	2047	1812	1662	1472	1406	1350	1263	1196	1142	—	
					100000	3317	26741	2386	2047	1662	1472	1350	1196	1142	1097	1026	971	927	—	
1 1/2 1 11/16	1.36	6140	3530	2600	5000	6934	6934	6934	6485	5268	4664	4279	3789	3617	3475	3250	3077	—	—	
					10000	6934	6934	6140	5268	4279	3789	3475	3077	2938	2823	2640	2500	—	—	
					30000	6140	4987	4416	3789	3077	2725	2500	2213	2113	2030	1899	1798	—	—	
					50000	5268	4279	3789	3250	2640	2338	2144	1899	1813	1742	1629	1542	—	—	
					100000	4279	3475	3077	2640	2144	1899	1742	1542	1473	1415	1323	1253	—	—	
1 3/4 1 15/16 2	1.83	8070	4640	2540	5000	9114	9114	9114	8524	6923	6130	5624	4979	4754	4568	4272	—	—	—	
					10000	9114	9114	8070	6923	5624	4979	4568	4045	3862	3710	3470	—	—	—	
					30000	8070	6555	5804	4979	4045	3581	3285	2909	2777	2668	2496	—	—	—	
					50000	6923	5624	4979	4272	3470	3072	2818	2496	2383	2289	2141	—	—	—	
					100000	5624	4568	4045	3470	2818	2496	2289	2027	1935	1859	1739	—	—	—	
2 3/16	1.65	8570	4910	2980	5000	9679	9679	9679	9052	7352	6510	5972	5288	5049	4851	4537	—	—	—	
					10000	9679	9679	8570	7352	5972	5288	4851	4295	4101	3940	3685	—	—	—	
					30000	8570	6961	6164	5288	4295	3803	3489	3089	2950	2834	2650	—	—	—	
					50000	7352	5972	5288	4537	3685	3263	2993	2650	2530	2431	2274	—	—	—	
					100000	5972	4851	4295	3685	2993	2650	2431	2153	2055	1975	1847	—	—	—	
2 1/4 2 7/16 2 1/2	1.51	9030	5220	3470	5000	10198	10198	10198	9538	7747	6860	6293	5572	5320	5111	—	—	—	—	
					10000	10198	10198	9030	7747	6293	5572	5111	4526	4321	4152	—	—	—	—	
					30000	9030	7335	6495	5572	4526	4007	3676	3255	3108	2986	—	—	—	—	
					50000	7747	6293	5572	4780	3883	3438	3154	2793	2666	2562	—	—	—	—	
					100000	6293	5111	4526	3883	3154	2793	2562	2268	2166	2081	—	—	—	—	
2 11/16 2 15/16 3	1.30	9630	5510	4260	5000	10876	10876	10876	10171	8262	7316	6711	5942	5674	—	—	—	—	—	
					10000	10876	10876	9630	8262	6711	5942	5451	4826	4608	—	—	—	—	—	
					30000	9630	7822	6926	5942	4826	4274	3920	3471	3314	—	—	—	—	—	
					50000	8262	6711	5942	5098	4141	3666	3363	2978	2843	—	—	—	—	—	
					100000	6711	5451	4826	4141	3363	2978	2732	2419	2310	—	—	—	—	—	
3 3/16 3 7/16 3 1/2	1.19	15320	8790	7410	5000	17302	17302	17302	16181	13143	11638	10676	9453	—	—	—	—	—	—	
					10000	17302	17302	15320	13143	10676	9453	8671	7678	—	—	—	—	—	—	
					30000	15320	12444	11018	9453	7678	6799	6273	5522	—	—	—	—	—	—	
					50000	13143	10676	9453	8110	6587	5833	5351	4738	—	—	—	—	—	—	
					100000	10676	8671	7678	6587	5351	4738	4346	3848	—	—	—	—	—	—	
3 15/16 4	1.23	20980	12100	9800	5000	23694	23694	23694	22159	17999	15938	14620	12945	—	—	—	—	—	—	
					10000	23694	23694	20980	17999	14620	12945	11875	10515	—	—	—	—	—	—	
					30000	20980	17041	15089	12945	10515	9311	8411	7563	—	—	—	—	—	—	
					50000	17999	14620	12945	11106	9021	7988	7327	6488	—	—	—	—	—	—	
					100000	14620	11875	10515	9021	7327	6488	5952	5270	—	—	—	—	—	—	
4 7/16 4 1/2	1.13	25750	14800	13100	5000	29081	29081	29081	27198	22091	19561	17944	—	—	—	—	—	—	—	
					10000	29081	29081	25750	22091	17944	15889	14575	—	—	—	—	—	—	—	
					30000	25750	20915	18520	15889	12906	11427	10483	—	—	—	—	—	—	—	
					50000	22091	17944	15889	13631	11072	9804	8993	—	—	—	—	—	—	—	
					100000	17944	14575	12906	11072	8993	7963	7305	—	—	—	—	—	—	—	
4 15/16 5	1.27	35520	20400	16000	5000	40114	40114	40114	37517	30473	26983	24752	—	—	—	—	—	—	—	
					10000	40114	40114	35520	30473	24752	21917	20105	—	—	—	—	—	—		
					30000	35520	28851	25547	21917	17802	15763	14460	—	—	—	—	—	—		
					50000	30473	24752	21917	18803	15273	13524	12405	—	—	—	—	—	—		
					100000	24752	20105	17802	15273	12405	10985	10076	—	—	—	—	—	—		

Spherical Roller Bearings

SPB1000

Extended Inner Race with Concentric Locking Collar and Two Setscrews

Self-Aligning Double Row Spherical Roller Bearings

Elongated Bolt Holes with Two and Four Bolt Housings

One Piece Cast Iron Housing

Contact Seal for 1000 & 1100 Series To Specify Add C Example: SPB1000NECx2 7/16"

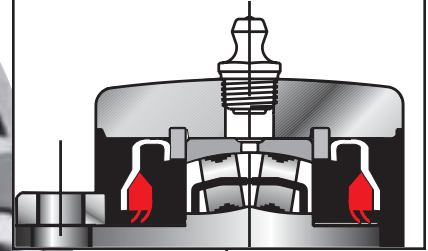

MULTI-TRAP® Seal

SPB1100

Ductile Iron Housing

BROWNING SPHERICAL ROLLER BEARINGS 1000/1100 SERIES FEATURES/BENEFITS

Note: Other features are like the 1000 Series

LOCKING

1000/1100 LOCKING - A concentric locking collar with two set screws anchor the bearing to the inner race. The elastic deflection of the collar serves to help retain the bearing on the shaft. Set screws are located at 62° for improved holding power and resistance to back out especially in applications with heavy vibration or unidirectional loads. Browning lock collars are black oxide coated for corrosion resistance.

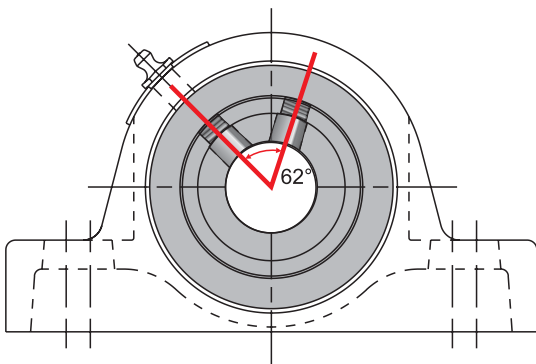

SEALS

1000/1100 SEALING - The Browning MULTI-TRAP® seal offers additional protection against contaminant entry and provides for grease retention. The labyrinth seal is constructed of three components with a rotating flinger to help direct contamination away from the sealing surfaces during operational or dynamic misalignment. These self-aligning, non-contact seals reduce drag and save energy and normally cannot be blown by over greasing. Black oxide offers additional protection against corrosion. Browning also offers a double lip contact seal with integral metal shield help protect against contaminants. It has good grease retention characteristics in operating temperatures up to 200° F. Contact seals are standard on the 4 7/16" - 4 15/16" 1000 series pillow blocks and optional on all other 1000 and 1100 series.

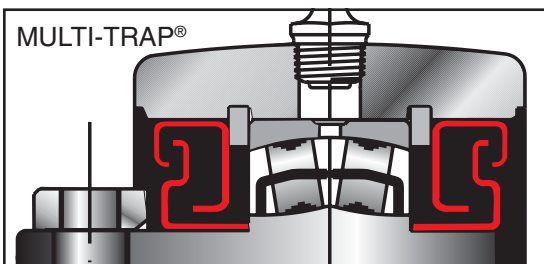

See page 156 for trademark acknowledgments.

BROWNING SPHERICAL ROLLER BEARINGS 1000/1100 SERIES FEATURES/BENEFITS

HOUSINGS



CAST IRON

1000 HOUSING - Browning compact, solid, one piece, cast iron housings provide strength and load support in a wide variety of applications.

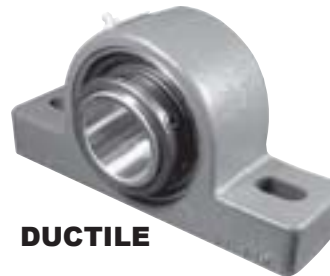

DUCTILE

1100 HOUSING - 1100 Series ductile iron housings are approximately twice as strong as cast iron. This is an important feature in applications such as sawmills where heavy loads and shock conditions are normally experienced.

TABLE OF CONTENTS

SPB1000 Pillow Blocks	128
SFB1000 Flange Blocks	130
SFC1000 Flange Cartridges	134
STU1000 Take-Ups	132
T1000 Take-Up Frames	133
1000 Ratings	139
1000 Series Interchange Tables .	166

SPB1100 Pillow Blocks	136
SFB1100 Flange Blocks	137
SFC1100 Flange Units	138
1100 Ratings	139
1100 Interchange Tables	166

SPB1000

Lock: Set Screw
 Seal: MULTI-TRAP[®] Labyrinth
 Housing: Cast Iron
 Temperatures: -20°F to 200°F
 Optional Seal: Double Lip Contact
 Self Aligning: ±1 1/2°
 Fitting: 1/8" NPT

Load Rating Tables: Page 139
 Interchange Tables: Page 166

Expansion and Non-Expansion

S SPHERICAL ROLLER
P PILLOW
B BLOCK
1 1000 SERIES
0 SET SCREW LOCK
0 CAST IRON
0 BEARING

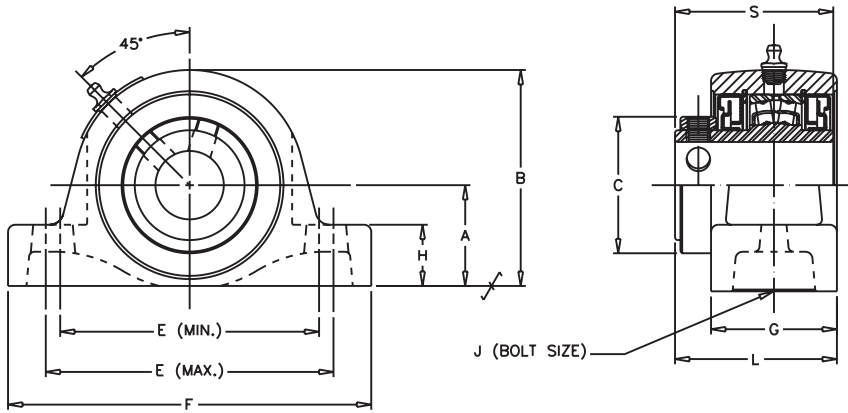

SHAFT DIA. IN.	Dimensions in Inches											UNIT WT.
	A	B	C	E		F	G	H	J	L*	S	
				MIN	MAX							
1 1/8												
1 3/16	1 3/4	3 3/4	2 15/32	4 1/2	5	6 5/16	2 3/16	1 1/16	3/8	2 27/32	2 3/4	6.5
1 1/4												
1 7/16	1 7/8	3 7/8	2 15/32	4 11/16	5 5/16	6 7/8	2 3/16	1 3/16	1/2	2 27/32	2 3/4	6.9
1 1/2												
1 11/16	2 1/8	4 1/4	2 23/32	5 3/16	5 13/16	7 3/8	2 3/16	1 5/16	1/2	2 31/32	2 7/8	8.1
1 3/4												
1 15/16	2 1/4	4 9/16	2 29/32	5 15/16	6 9/16	8 3/8	2 3/16	1 3/8	5/8	2 31/32	2 7/8	9.1
2												
2 3/16	2 1/2	5	3 1/4	6 9/16	7 1/16	8 7/8	2 7/16	1 5/8	5/8	3 7/32	3 1/8	11.8
2 7/16												
2 1/2	2 3/4	5 11/16	4	6 13/16	7 7/16	9 1/4	2 11/16	1 3/4	5/8	3 15/32	3 3/8	16.2
2 11/16												
2 3/4	3 1/4	6 7/16	4 3/8	7 13/16	8 7/16	10 7/16	2 13/16	2 1/4	3/4	3 25/32	3 5/8	22.1
2 15/16												
3												
3 3/16	3 3/4	7 1/2	5 1/8	9 1/4	10 3/4	13	3 3/16	2 1/4	7/8	4 3/16	4 1/32	31.6
3 7/16												
3 1/2												
3 11/16	4 1/8	8 7/16	6	10	11 3/4	14 1/4	3 9/16	2 1/2	1	4 3/4	4 19/32	44.6
3 15/16												
4												

*These dimensions are for Non-Expansion units. For expansion type, adjust ±.050."

Non-Expansion Pillow Block Part Numbers are specified by "SPB1000NE" and bore size: Example, **SPB1000NEx 2 7/16"**. For Contact Seals Add "C" to prefix: Example, **SPB1000NECx 2 7/16"**.

Expansion Pillow Block Part Numbers are specified by "SPB1000E" and bore size: Example, **SPB1000Ex 2 7/16"**. For Contact Seals Add "C" to prefix: Example, **SPB1000ECx 2 7/16"**.

Self-aligning with contacts seals ± 1 1/4°.

Spherical Roller Bearings

SPB1000F



SPHERICAL ROLLER S
PILLOW P
BLOCK B

1000 SERIES 1
SET SCREW LOCK 0
CAST IRON 0
BEARING 0
FOUR BOLT BASE F

Lock: Set Screw
Seal: MULTI-TRAP® Labyrinth
Housing: Cast Iron
Temperatures: -20°F to 200°F
Optional Seal: Double Lip Contact
Self Aligning: ±1 1/2°
Fitting: 1/8" NPT

Load Rating Tables: Page 139
Interchange Tables: Page 166

Expansion and Non-Expansion

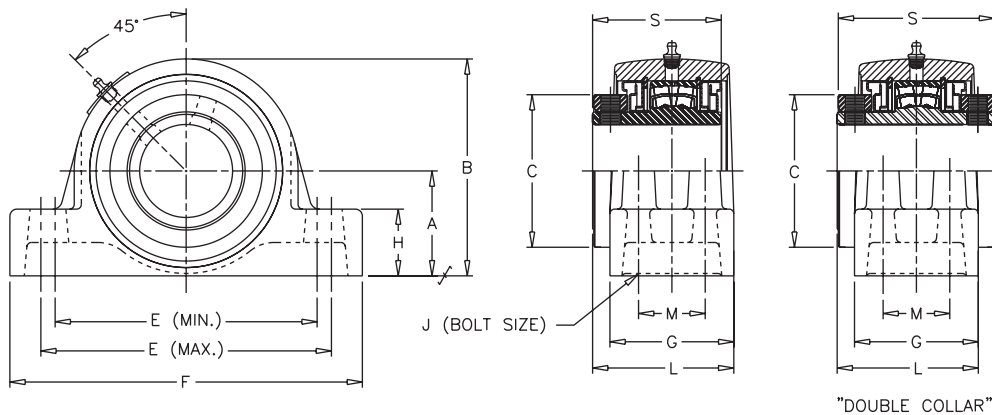

SHAFT DIA. IN.	Dimensions in Inches												UNIT WT.
	A	B	C	E		F	G	H	J	L*	M	S	
				MIN	MAX								
2 7/16													
2 1/2	2 3/4	5 11/16	4	6 7/8	7 5/8	9 1/4	3 1/4	1 3/4	1/2	3 3/4	1 3/4	3 3/8	16.5
2 11/16													
2 3/4													
2 15/16	3 1/4	6 7/16	4 3/8	7 7/8	8 3/8	10 7/16	3 3/4	2 1/4	5/8	4 1/4	1 7/8	3 5/8	26.0
3													
3 3/16													
3 7/16	3 3/4	7 1/2	5 1/8	9 1/4	10 3/4	13	3 7/8	2 1/4	3/4	4 17/32	2	4 1/32	37.5
3 1/2													
3 11/16													
3 15/16	4 1/4	8 9/16	6	11	13	15 1/4	4 1/2	2 5/8	3/4	5 7/32	2 1/4	4 19/32	50.0
4													
▲ 4 7/16	4 3/4	9 3/8	6 1/8	13 1/8	13 7/8	16 5/8	4 5/8	2 3/4	3/4	5 3/8	2 1/2	6 1/8	71.0
▲ 4 1/2													
▲ 4 15/16	5 1/2	10 7/8	6 7/8	15 1/8	15 7/8	18 1/2	5 1/8	3	7/8	5 7/8	2 3/4	6 5/8	100.0

*These dimensions are for Non-Expansion units. For expansion type, adjust ±.050."

Non-Expansion Pillow Block Part Numbers are specified by "SPB1000FNE" and bore size: Example, **SPB1000FNEx 2 7/16"**. For Contact Seals Add "C" to prefix: Example, **SPB1000FNECx 2 7/16"**.

Expansion Pillow Block Part Numbers are specified by "SPB1000FE" and bore size: Example, **SPB1000FEEx 2 7/16"**. For Contact Seals Add "C" to prefix: Example, **SPB1000FEEx 2 7/16"**.

Self-aligning with contacts seals ± 1 1/4°.

▲ Available with contacts seals and double locking collars only.

See page 156 for trademark acknowledgments.



1000

Browning®

Spherical Roller Bearings

SFB1000

Lock: Set Screw
Seal: MULTI-TRAP® Labyrinth
Housing: Cast Iron
Temperatures: -20°F to 200°F
Optional Seal: Double Lip Contact
Self Aligning: ±1 1/2°
Fitting: 1/8" NPT

Load Rating Tables: Page 139
Interchange Tables: Page 166

Expansion and Non-Expansion

S SPHERICAL ROLLER
F FLANGE
B BLOCK
1 1000 SERIES
0 SET SCREW LOCK
0 CAST IRON
0 BEARING

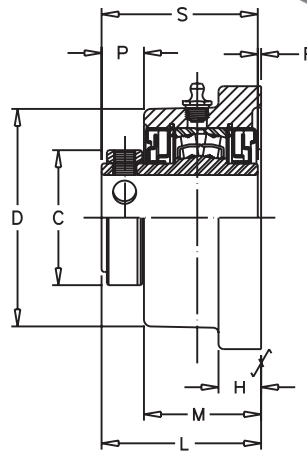
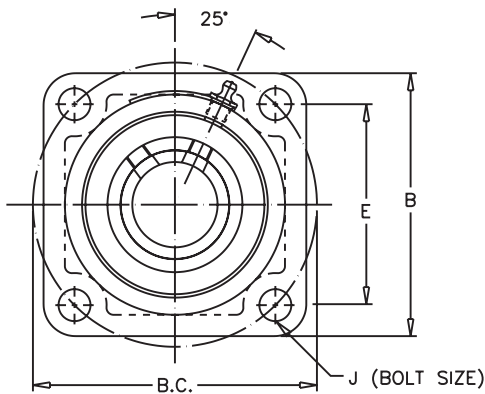

SHAFT DIA. IN.	Dimensions In Inches												UNIT WT.
	B	BC	C	D	E	H	J	L*	M	P	R*	S	
1 7/16 1 1/2	4 5/8	5	2 15/32	3 7/8	3 35/64	3/4	1/2	2 13/16	2 1/16	3/4	1/16	2 3/4	6.8
1 11/16 1 3/4	5	5 1/2	2 23/32	4 1/2	3 57/64	3/4	1/2	3 3/64	2 1/4	3/4	11/64	2 7/8	9.8
1 15/16 2	5 3/16	5 3/4	2 29/32	4 3/4	4 5/64	3/4	1/2	3 3/64	2 1/4	3/4	11/64	2 7/8	10.3
2 3/16	5 7/8	6 3/8	3 1/4	5 1/8	4 1/2	13/16	5/8	3 19/64	2 7/16	13/16	11/64	3 1/8	12.2
2 7/16 2 1/2	6 1/8	6 3/4	4	5 3/4	4 25/32	1 1/32	5/8	3 35/64	2 21/32	27/32	11/64	3 3/8	16.2
2 11/16 2 3/4 2 15/16 3	7 3/16	7 7/8	4 3/8	6 5/8	5 37/64	15/16	3/4	3 59/64	2 7/8	1	19/64	3 5/8	25.1
3 3/16 3 7/16 3 1/2	8 3/8	9 1/2	5 1/8	7 5/8	6 23/32	1 1/8	3/4	4 21/64	3 9/32	1	19/64	4 1/32	35.0
3 11/16 3 15/16 4	9 1/2	10 3/4	6	8 3/8	7 39/64	1 3/16	7/8	4 53/64	3 9/16	1 9/32	15/64	4 19/32	48.0

Non-Expansion Pillow Block Part Numbers are specified by "SFB1000NE" and bore size: Example, **SFB1000NEx 2 7/16"**. For Contact Seals Add "C" to prefix: Example, **SFB1000NECx 2 7/16"**.

Expansion Pillow Block Part Numbers are specified by "SFB1000E" and bore size: Example, **SFB1000Ex 2 7/16"**. For Contact Seals Add "C" to prefix: Example, **SFB1000ECx 2 7/16"**.

Self-aligning with contacts seals ± 1 1/4°.

Spherical Roller Bearings

SFB1000-3&4

SPHERICAL ROLLER S
FLANGE F
BASE B

1000 SERIES 1
SET SCREW LOCK 0
CAST IRON 0
BEARING 0

THREE OR FOUR BOLT MOUNTING 3

Lock: Set screw
Seal: MULTI-TRAP® Labyrinth
Housing: Cast Iron
Temperatures: -20°F to 200°F
Optional Seal: Double Lip Contact
Self Aligning: ±1 1/2°
Fitting: 1/4" NPT

Load Rating Tables: Page 139
Interchange Tables: Page 166

Expansion and Non-Expansion

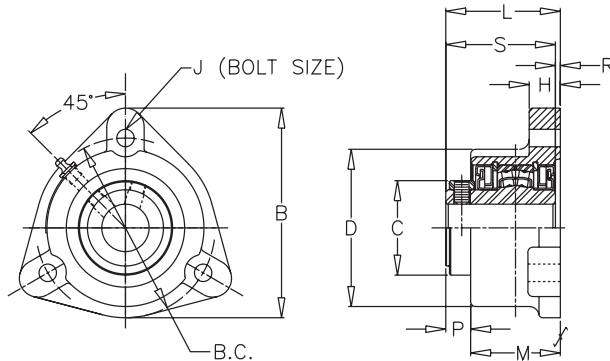

SHAFT DIA. IN.	Dimensions in Inches											UNIT WT.	
	B	BC	C	D	H	J	L*	M	P	R*	S		
1 1/8													7.3
1 3/16	5 1/4	4 1/2	2 15/32	3 15/16	25/32	3/8	2 7/8	2 1/4	5/8	1/8	2 3/4		
1 1/4													
1 7/16													6.8
1 1/2	5 1/4	5	2 15/32	3 15/16	25/32	1/2	2 7/8	2 1/4	5/8	1/8	2 3/4		

*Dimensions L and R are for non-expansion unit. For expansion type, increase L and R by .098" max.

Non-Expansion Flange Block part numbers are SFB1000NE-3 and bore size. Example: SFB1000NE-3 x 1 1/8. For contact seal add "C" to prefix:

Example: **SFB1000NE3C x 1 1/8"**.

Expansion Flange Block part numbers are SFB1000E-3 and bore size. Example: SFB1000E-3 x 1 1/8. For contact seal add "C" to prefix:

Example: **SFB1000E3C x 1 1/8"**.

Self-aligning with contacts seals ± 1 1/4°.

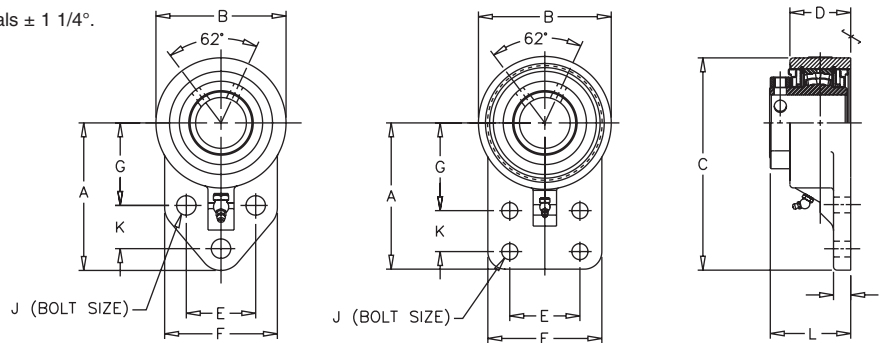

SHAFT DIA. IN	UNIT DESCRIPTION	Dimensions in Inches											UNIT WT.
		A	B	C	D	E	F	G	H	J	K	L*	
THREE BOLT													
1 7/16	SFB1000NE3	4 1/4	3 3/4	6 1/8	2 1/4	2	3 1/4	2 3/8	5/8	1/2	1 1/4	3	6.8
1 15/16	SFB1000NE3	5 3/16	4 1/4	7 5/16	2 3/8	2 3/4	4	2 15/16	11/16	1/2	1 5/8	3 11/64	8.3
FOUR BOLT													
2 7/16	SFB1000NE4	6 1/4	5 11/16	9 3/32	2 21/32	3	4 7/8	3 3/4	3/4	5/8	1 3/4	3 35/64	13.5

*These dimensions are for non-expansion unit. For expansion type, adjust ±.040.

Expansion 3 Bolt Flange Block part numbers are SBF1000E3 and bore size. Example SBF1000E3 X 1 7/16.

Expansion 4 Bolt Flange Block part numbers are SBF1000E4 and bore size. Example SBF1000E4 x 2 7/16.

For Contact Seals add "C" to prefix: Example SBF1000NEC4 X 2 7/16.

See page 156 for trademark acknowledgments.



1000

Browning®

Spherical Roller Bearings

STU1000

Lock: Set Screw
Seal: MULTI-TRAP® Labyrinth
Housing: Cast Iron
Temperatures: -20°F to 200°F
Optional Seal: Double Lip Contact
Self Aligning: ±1 1/2°
Fitting: 1/8" NPT

Load Rating Tables: Page 139
Interchange Tables: Page 166

S SPHERICAL ROLLER
T TAKE
U UP

1 1000 SERIES
0 SET SCREW LOCK
0 CAST IRON
0 BEARING

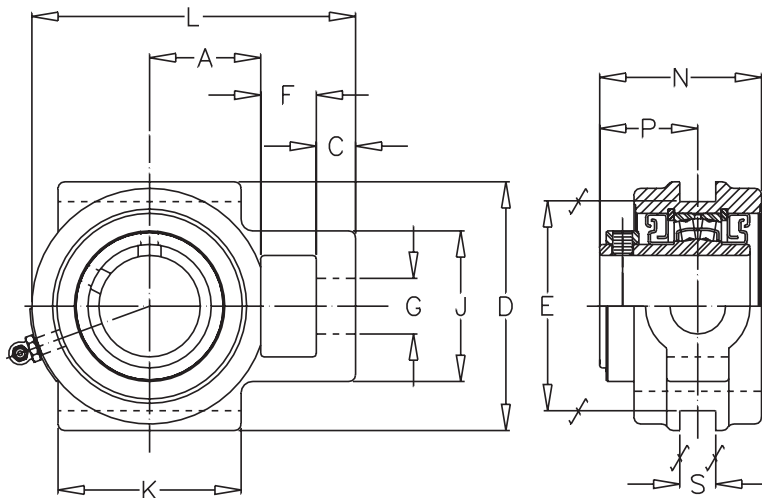

SHAFT DIA. IN.	Dimensions In Inches												UNIT WT.
	A	C	D	E	F	G*	J	K	L	N	P	S	
1 15/16 2	2 1/8	3/4	4 3/4	4	1 1/16	1 1/16	2 7/8	3 1/2	6 3/16	3 3/32	1 7/8	11/16	15.0
2 3/16	2 3/8	3/4	5 1/4	4 1/2	1 3/16	1 3/16	3 1/2	3 3/4	6 13/16	3 9/32	2	13/16	18.0
2 7/16 2 1/2	2 3/4	7/8	5 7/8	5 1/8	1 5/16	1 5/16	3 3/4	4 3/4	7 15/16	3 15/32	2 1/8	1 1/16	24.0
2 11/16 2 3/4 2 15/16 3	3	1	6 3/4	5 15/16	1 9/16	1 9/16	4 1/4	4 3/4	8 3/4	3 7/8	2 3/8	1 13/16	30.0
3 3/16 3 7/16 3 1/2	3 5/8	1	7 5/8	6 13/16	1 13/16	1 13/16	4 7/8	6 1/4	10 7/16	4 7/16	2 19/32	1 13/16	38.0
3 11/16 3 15/16 4	4 1/8	1 1/8	9 7/16	8 5/8	2 1/8	2 3/16	5 5/8	7	11 13/16	5 7/32	2 31/32	2 1/16	48.0

*These dimensions are for Non-Expansion units. For expansion type, adjust ±.050."

Part Numbers are specified by "STU1000NE" and bore size: Example, **STU1000NEx 3 7/16"**.

For Contact Seals Add "C" to prefix: Example **STU1000NECx 3 7/16"**.

These Take-Up Bearings are to be used with T1000 Take-Up Frames shown on page 133.

Bearing unit and frame must be ordered separately.

Self-aligning with contacts seals ± 1 1/4°.

Spherical Roller Bearings

T1000



TAKE UP FRAME T

1000 SERIES 1

0
0
0

Material:

All Steel
Construction

Exclusive Design:

Removable Top
Permits Assembling of Take-Up Unit on Shaft Before Inserting in Take-Up Frame.

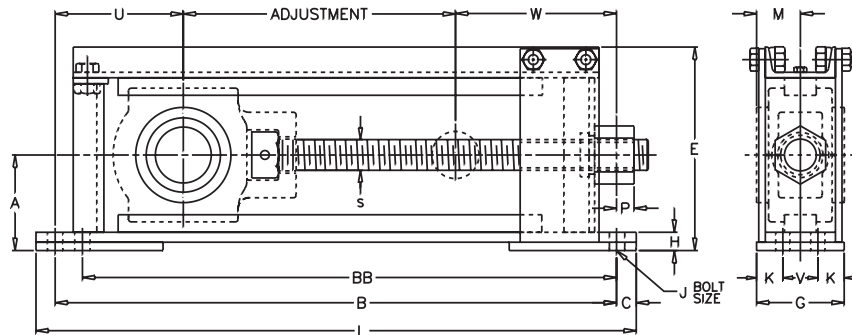

SHAFT DIA. IN	FRAME PART NO.	Adjustment*		Dimensions In Inches																Bolts Req'd		UNIT WT.
		No.-m.	Actual	A	B	BB	C	E	G	H	K	L	M	S	P	U	V	W	No.	Size J		
1 15/16	12-16.5T1000D	12	16.5	3 15/16	27 1/2	26 1/2	1	8 9/32	4	1 1/4	-	29 1/2	1 7/8	1-8NC	1 1/4	5 3/8	-	5 5/8	2	5/8	60	
	18-22.5T1000D	18	22.5	3 15/16	33 1/2	32 1/2	1	8 9/32	4	1 1/4	-	35 1/2	1 7/8	1-8NC	1 1/4	5 3/8	-	5 5/8	2	5/8	70	
	24-28.5T1000D	24	28.5	3 15/16	39 1/2	38 1/2	1	8 9/32	4	1 1/4	-	41 1/2	1 7/8	1-8NC	1 1/4	5 3/8	-	5 5/8	2	5/8	80	
2 3/16	12-17T1000EL	12	17	4 3/16	27 1/2	-	1	8 21/32	4	1 3/8	-	29 1/2	2	1 1/8-7NC	1 5/8	4 9/16	-	5 15/16	2	5/8	65	
	18-23T1000EL	18	23	4 3/16	33 1/2	-	1	8 21/32	4	1 3/8	-	35 1/2	2	1 1/8-7NC	1 5/8	4 9/16	-	5 15/16	2	5/8	77	
	24-29T1000EL	24	29	4 3/16	39 1/2	-	1	8 21/32	4	1 3/8	-	41 1/2	2	1 1/8-7NC	1 5/8	4 9/16	-	5 15/16	2	5/8	86	
2 3/16	12-17T1000EH	12	17	4 7/16	27 1/2	-	1	8 29/32	4	1 5/8	-	29 1/2	2	1 1/8-7NC	1 5/8	4 9/16	-	5 15/16	2	5/8	68	
	18-23T1000EH	18	23	4 7/16	33 1/2	-	1	8 29/32	4	1 5/8	-	35 1/2	2	1 1/8-7NC	1 5/8	4 9/16	-	5 15/16	2	5/8	80	
	24-29T1000EH	24	29	4 7/16	39 1/2	-	1	8 29/32	4	1 5/8	-	41 1/2	2	1 1/8-7NC	1 5/8	4 9/16	-	5 15/16	2	5/8	91	
2 7/16	12-16.6T1000F	12	16.6	4 3/8	28 1/2	-	1	9 3/16	4	1 1/8	-	30 1/2	2 1/8	1 1/4-7NC	1 3/4	5 5/16	-	6 9/16	2	3/4	71	
	18-22.6T1000F	18	22.6	4 3/8	34 1/2	-	1	9 3/16	4	1 1/8	-	36 1/2	2 1/8	1 1/4-7NC	1 3/4	5 5/16	-	6 9/16	2	3/4	81	
	24-28.6T1000F	24	28.6	4 3/8	40 1/2	-	1	9 3/16	4	1 1/8	-	42 1/2	2 1/8	1 1/4-7NC	1 3/4	5 5/16	-	6 9/16	2	3/4	91	
2 1/2	30-34.6T1000F	30	34.6	4 3/8	46 1/2	-	1	9 3/16	4	1 1/8	-	48 1/2	2 1/8	1 1/4-7NC	1 3/4	5 5/16	-	6 9/16	2	3/4	111	
	2 11/16	12-15.5T1000GL	12	15.5	4 15/16	30 1/2	-	1	10 11/16	5	31/32	1 1/2	32 1/2	2 3/8	1 1/2-6NC	1/2	6 1/2	2	8 1/2	4	5/8	105
	2 3/4	18-21.5T1000GL	18	21.5	4 15/16	36 1/2	-	1	10 11/16	5	31/32	1 1/2	38 1/2	2 3/8	1 1/2-6NC	1/2	6 1/2	2	8 1/2	4	5/8	120
2 15/16	24-27.5T1000GL	24	27.5	4 15/16	42 1/2	-	1	10 11/16	5	31/32	1 1/2	44 1/2	2 3/8	1 1/2-6NC	1/2	6 1/2	2	8 1/2	4	5/8	135	
	3	30-33.5T1000GL	30	33.5	4 15/16	48 1/2	-	1	10 11/16	5	31/32	1 1/2	50 1/2	2 3/8	1 1/2-6NC	1/2	6 1/2	2	8 1/2	4	5/8	150
	2 11/16	12-15.5T1000GH	12	15.5	5 1/8	30 1/2	-	1	10 7/8	5	1 5/32	1 1/2	32 1/2	2 3/8	1 1/2-6NC	1/2	6 1/2	2	8 1/2	4	5/8	109
2 3/4		18-21.5T1000GH	18	21.5	5 1/8	36 1/2	-	1	10 7/8	5	1 5/32	1 1/2	38 1/2	2 3/8	1 1/2-6NC	1/2	6 1/2	2	8 1/2	4	5/8	126
2 15/16		24-27.5T1000GH	24	27.5	5 1/8	42 1/2	-	1	10 7/8	5	1 5/32	1 1/2	44 1/2	2 3/8	1 1/2-6NC	1/2	6 1/2	2	8 1/2	4	5/8	141
	3	30-33.5T1000GH	30	33.5	5 1/8	48 1/2	-	1	10 7/8	5	1 5/32	1 1/2	50 1/2	2 3/8	1 1/2-6NC	1/2	6 1/2	2	8 1/2	4	5/8	156
3 3/16	12-15.5T1000JL	12	15.5	5 7/16	32	-	1 1/8	11 5/8	5	1 1/32	1 1/2	34 1/4	2 19/32	1 3/4-5NC	1	7 5/16	2	9 3/16	4	3/4	138	
	3 7/16	18-21.5T1000JL	18	21.5	5 7/16	38	-	1 1/8	11 5/8	5	1 1/32	1 1/2	40 1/4	2 19/32	1 3/4-5NC	1	7 5/16	2	9 3/16	4	3/4	156
	3 1/2	24-27.5T1000JL	24	27.5	5 7/16	44	-	1 1/8	11 5/8	5	1 1/32	1 1/2	46 1/4	2 19/32	1 3/4-5NC	1	7 5/16	2	9 3/16	4	3/4	173
3		30-33.5T1000JL	30	33.5	5 7/16	50	-	1 1/8	11 5/8	5	1 1/32	1 1/2	52 1/4	2 19/32	1 3/4-5NC	1	7 5/16	2	9 3/16	4	3/4	191
3 3/16	12-15.5T1000JH	12	15.5	5 5/8	32	-	1 1/8	11 13/16	5	1 7/32	1 1/2	34 1/4	2 19/32	1 3/4-5NC	1	7 5/16	2	9 3/16	4	3/4	145	
	3 7/16	18-21.5T1000JH	18	21.5	5 5/8	38	-	1 1/8	11 13/16	5	1 7/32	1 1/2	40 1/4	2 19/32	1 3/4-5NC	1	7 5/16	2	9 3/16	4	3/4	163
		3 1/2	24-27.5T1000JH	24	27.5	5 5/8	44	-	1 1/8	11 13/16	5	1 7/32	1 1/2	46 1/4	2 19/32	1 3/4-5NC	1	7 5/16	2	9 3/16	4	3/4
3	30-33.5T1000JH		30	33.5	5 5/8	50	-	1 1/8	11 13/16	5	1 7/32	1 1/2	52 1/4	2 19/32	1 3/4-5NC	1	7 5/16	2	9 3/16	4	3/4	197
3 11/16	12-18T1000K	12	18	7	36	-	1 1/4	14 15/32	6	1 7/16	1 3/4	38 1/2	2 31/32	2-4 1/2NC	1 5/8	7 1/2	2 1/2	10 7/16	4	3/4	191	
	3 15/16	18-24T1000K	18	24	7	42	-	1 1/4	14 15/32	6	1 7/16	1 3/4	44 1/2	2 31/32	2-4 1/2NC	1 5/8	7 1/2	2 1/2	10 7/16	4	3/4	223
		24-30T1000K	24	30	7	48	-	1 1/4	14 15/32	6	1 7/16	1 3/4	50 1/2	2 31/32	2-4 1/2NC	1 5/8	7 1/2	2 1/2	10 7/16	4	3/4	249
	4	30-36T1000K	30	36	7	54	-	1 1/4	14 15/32	6	1 7/16	1 3/4	56 1/2	2 31/32	2-4 1/2NC	1 5/8	7 1/2	2 1/2	10 7/16	4	3/4	274

Part Numbers are specified by "T1000" with travel adjustment and bore size: Example, **12-16.6T1000F** has 12"-16.6" adjustment and will accommodate a STU1000x 2 7/16" bearing unit.

These Take-Up Frames are to be used with STU Take-Up Units shown on page 132.

Bearing unit and frame must be ordered separately.

*Nominal adjustment is that offered by competitive frames having the same length.

Browning frames give greater ACTUAL adjustment, often permitting use of shorter, more compact frames.

Browning frames with over 12" nominal adjustment have a third foot in the center for extra support.

See page 156 for trademark acknowledgments.



1000

SFC1000

Lock: Set Screw
Seal: MULTI-TRAP® Labyrinth
Housing: Cast Iron
Temperatures: -20°F to 200°F
Optional Seal: Double Lip Contact
Self Aligning: ±1 1/2°
Fitting: 1/4" -28NF

Load Rating Tables: Page 139
Interchange Tables: Page 166

Browning®

Spherical Roller Bearings

SPHERICAL ROLLER S
FLANGE F
CARTRIDGE C

1000 SERIES 1
SET SCREW LOCK 0
CAST IRON 0
BEARING 0

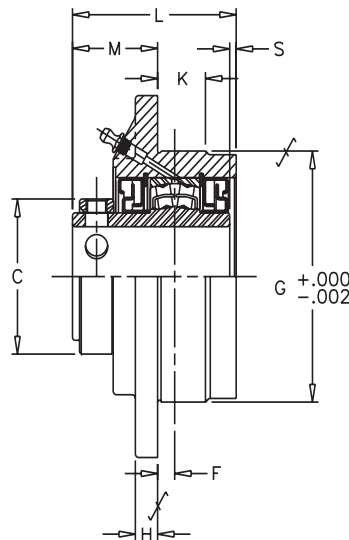
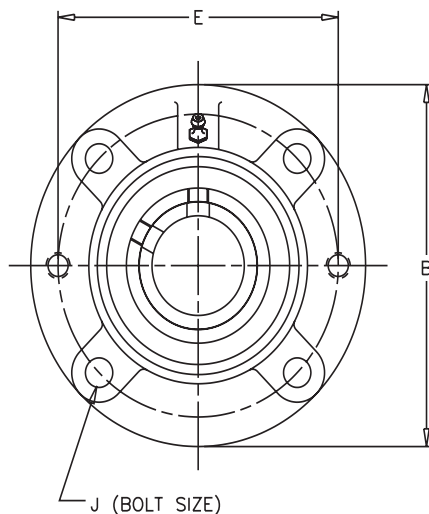

SHAFT DIA. IN.	Dimensions In Inches											UNIT WT.
	B	C	E	F*	G	H	J	K	L*	M*	S*	
1 7/16 1 1/2	5 1/4	2 15/32	4 3/8	1/4	3 5/8	15/32	3/8	-	2 3/4	1 33/64	1/16	6.6
1 11/16 1 3/4	6 1/8	2 23/32	5 1/8	19/64	4 1/4	15/32	7/16	7/8	3 1/64	1 37/64	9/64	8.2
1 15/16 2	6 3/8	2 29/32	5 3/8	21/64	4 1/2	17/32	7/16	7/8	3 1/64	1 9/16	9/64	10.4
2 3/16 2 7/16 2 1/2	7 1/8	3 1/4	6	9/32	5	17/32	1/2	1	3 7/32	1 3/4	3/32	14.5
2 11/16 2 3/4 2 15/16 3	8 3/4	4 3/8	7 1/2	13/32	6 3/8	23/32	5/8	1 1/4	3 27/32	2	7/32	22.0
3 3/16 3 7/16 3 1/2	10 1/4	5 1/8	8 5/8	9/32	7 3/8	27/32	3/4	1 1/4	4 9/64	2 19/64	7/64	33.0
3 11/16 3 15/16 4	10 7/8	6	9 3/8	5/16	8 1/8	31/32	3/4	1 1/2	4 3/4	2 21/32	9/64	45.0

*These dimensions are for Non-Expansion units. For expansion type, adjust ±.050."

REV 1

Non-Expansion Pillow Block Part Numbers are specified by "SFC1000NE" and bore size: Example, **SFC1000NEx 2 7/16"**. For Contact Seals Add "C" to prefix: Example, **SFC1000NECx 2 7/16"**.

Expansion Pillow Block Part Numbers are specified by "SFC1000E" and bore size: Example, **SFC1000Ex 2 7/16"**. For Contact Seals Add "C" to prefix: Example, **SFB1000ECx 2 7/16"**.

Self-aligning with contacts seals ± 1 1/4°.

Spherical Roller Bearings

Tapered Roller Bearings Series (900, E920, 970, 950)

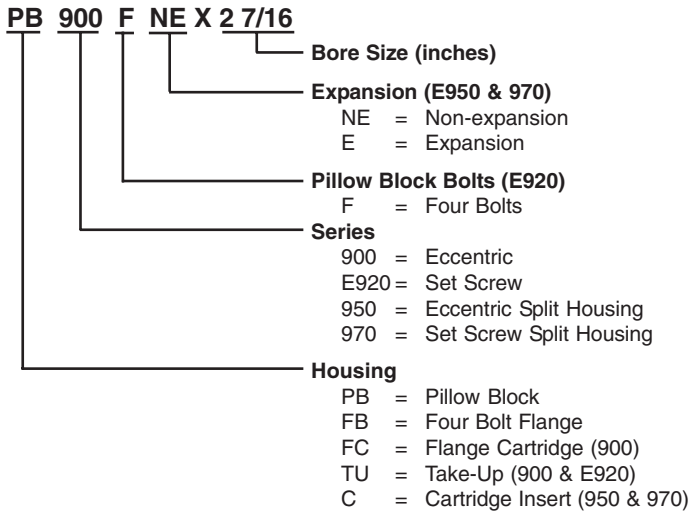

Spherical Roller Bearings Series (1000, 1100)

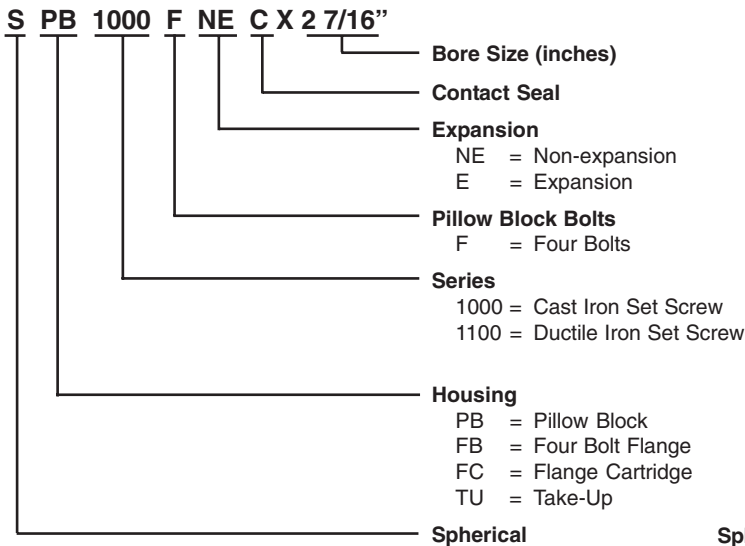

Part Number Explanation

Take-Up Frames

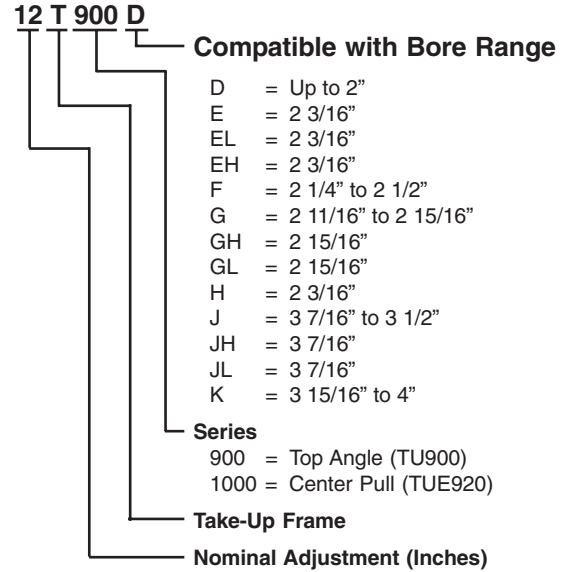

Spherical Roller Bearings Series (22500, 22200)

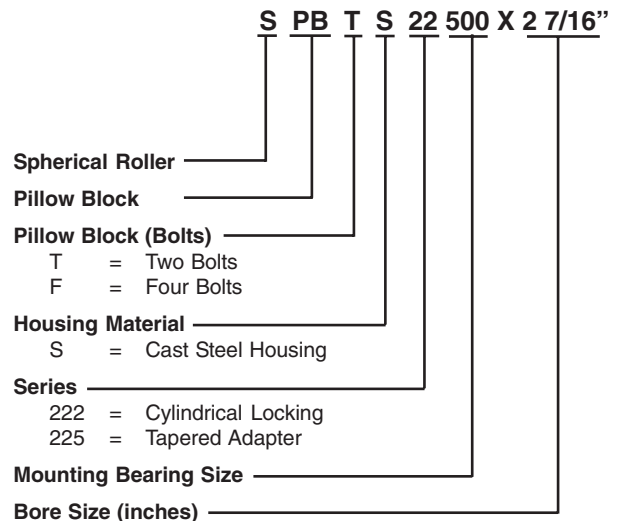

SPB1100

Lock: Set Screw
Seal: MULTI-TRAP® Labyrinth
Housing: Ductile Iron
Temperatures: -20° to 200°F
Optional Seal: Double Lip Contact
Self Aligning: ±1 1/2°
Fitting: 1/8" NPT
Bolt Holes: Elongated

S SPHERICAL ROLLER
P PILLOW
B BLOCK

1 1100 SERIES
1 SET SCREW
0 DUCTILE IRON
0 BEARING



Load Rating Tables: Page 139
Interchange Tables: Page 166

Expansion and Non-Expansion

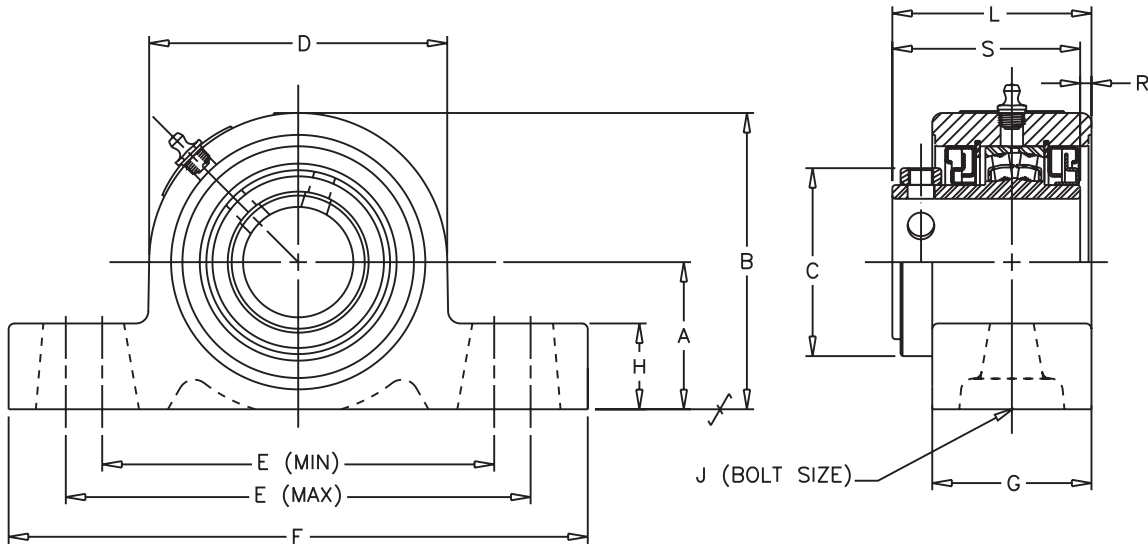

SHAFT DIA. IN.	Dimensions in Inches													UNIT WT.
	A	B	C	D	E		F	G	H	J	L*	R*	S	
					MIN	MAX								
1 15/16 2	2 1/4	4 17/32	3	4 9/16	6	7 1/8	8 7/8	2 7/16	1 5/16	5/8	3 3/32	7/32	2 7/8	11.2
2 3/16	2 1/2	4 31/32	3 3/8	4 15/16	6 1/2	7 7/8	9 5/8	2 1/2	1 7/16	5/8	3 1/4	1/8	3 1/8	13.4
2 7/16 2 1/2	2 3/4	5 5/8	3 3/8	5 1/4	6 7/8	8 5/8	10 3/8	2 53/64	1 9/16	5/8	3 35/64	11/64	3 3/8	18.6
2 11/16 2 3/4 2 15/16 3	3 1/8	6 1/16	4	5 7/8	7 7/8	9 5/8	11 5/8	2 5/8	1 5/8	3/4	3 11/16	1/16	3 5/8	19.9
3 3/16 3 7/16 3 1/2	3 3/4	7 3/8	4 11/16	7 1/4	9 3/8	11 1/4	13 1/2	3 1/8	1 7/8	7/8	4 5/32	1/8	4 1/32	34.1
3 11/16 3 15/16 4	4 1/8	8 1/2	6	8 1/8	10	11 3/4	14 1/4	3 9/16	2 1/4	1	4 23/32	1/8	4 19/32	50

*Dimensions L and R are for non-expansion unit. For expansion type, increase L and R by .098" max.
 Non-Expansion Pillow Block part numbers are **SPB1100NE** and bore size. Example: **SPB1100NE x 2 7/16**.
 Expansion Pillow Block part numbers are **SPB1100E** and bore size. Example: **SPB1100E x 2 7/16**.

Spherical Roller Bearings

SFB1100



SPHERICAL ROLLER S
FLANGE F
BLOCK B

1100 1
SET SCREW 1
DUCTILE IRON 0
BEARING 0

Lock: Set Screw
Seal: MULTI-TRAP® Labyrinth
Housing: Ductile Iron
Temperatures: -20°F to 200°F
Optional Seal: Double Lip Contact
Self Aligning: ±1 1/2°
Fitting: 1/8" NPT

Load Rating Tables: Page 139
Interchange Tables: Page 166

Expansion and Non-Expansion

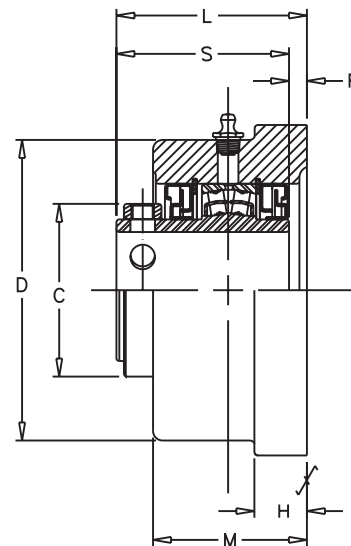
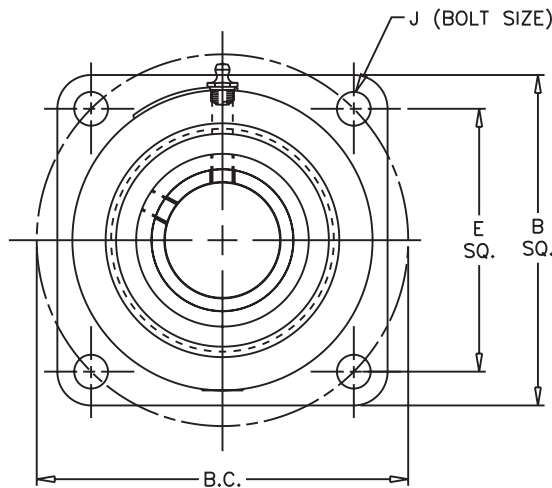

SHAFT DIA. IN.	Dimensions In Inches											UNIT WT.
	B	BC	C	D	E	H	J	L*	M	R*	S	
1 15/16 2	5 1/2	6 3/16	3	4 15/16	4 3/8	7/8	1/2	3 11/64	2 9/16	5/16	2 7/8	10.2
2 3/16 2 7/16 2 1/2	6 3/16	6 57/64	3 3/8	5 7/16	4 7/8	1	5/8	3 11/32	2 5/8	1/4	3 1/8	12.3
2 11/16 2 3/4 2 15/16 3	6 3/4	7 39/64	3 3/8	6 1/16	5 3/8	1	5/8	3 31/64	2 11/16	5/32	3 3/8	14.8
3 3/16 3 7/16 3 1/2	7 5/8	8 31/64	4	6 13/16	6	1 1/16	3/4	3 23/32	2 3/4	7/64	3 5/8	18.7
3 11/16 3 15/16 4	8 5/8	9 57/64	4 11/16	7 15/16	7	1 5/16	3/4	4 1/4	3 5/16	1/4	4 1/32	33.1
	9 1/2	10 3/4	6	8 29/32	7 19/32	1 1/4	7/8	5	3 11/16	27/64	4 19/32	48

*Dimensions L and R are for non-expansion unit. For expansion type, increase L and R by .098" max.
 Non-Expansion Flange Block part numbers are **SFB1100NE** and bore size. Example: **SFB1100NE x 3 7/16**.
 Expansion Flange Block part numbers are **SFB1100E** and bore size. Example: **SFB1100E x 3 7/16**.



1100

SFC1100

Lock: Set Screw
Seal: MULTI-TRAP® Labyrinth
Housing: Ductile Iron
Temperatures: - 20°F to 200°F
Optional Seal: Double Lip Contact
Self Aligning: ±1 1/2°
Fitting: 1/8" NPT

Load Rating Tables: Page 139

Interchange Tables: Page 166

Expansion and Non-Expansion

Browning®

Spherical Roller Bearings

S SPHERICAL ROLLER
F FLANGE
C CARTRIDGE
1 1100
1 SET SCREW
0 DUCTILE IRON
0 BEARING

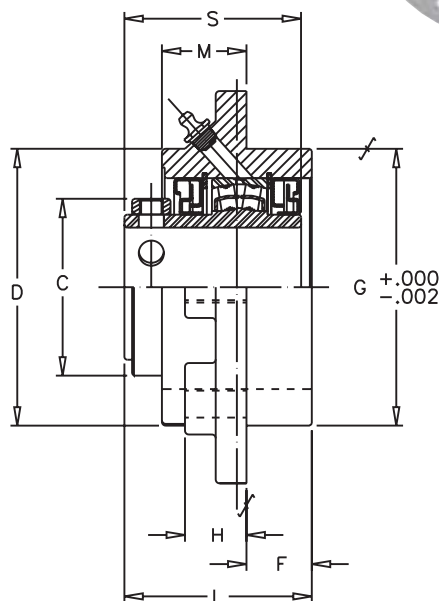
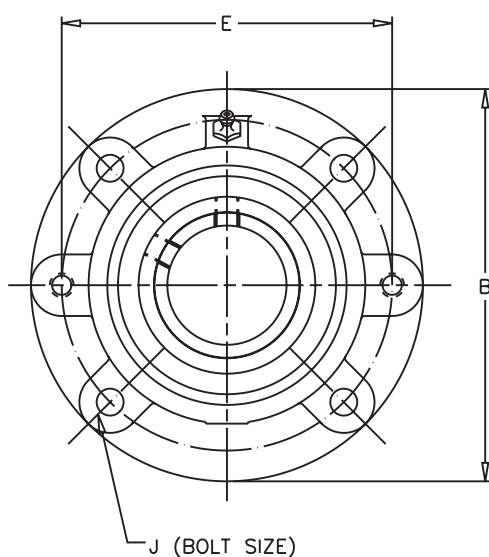

SHAFT DIA. IN.	Dimensions In Inches											UNIT WT.
	B	C	D	E	F	G	H	J	L*	M*	S	
1 15/16 2	6 3/8	2 29/32	4 1/2	5 3/8	1 1/16	4 1/2	1/2	3/8	3 3/32	1 3/8	2 7/8	10.0
2 3/16	7 1/8	3 1/4	4 7/8	6	1 1/8	5	1/2	1/2	3 1/4	1 3/8	3 1/8	14.0
2 7/16 2 1/2	7 5/8	4	5 3/8	6 1/2	1 1/8	5 1/2	9/16	1/2	3 13/32	1 7/16	3 3/8	15.5
2 11/16 2 3/4 2 15/16 3	8 3/4	4 3/8	6 1/4	7 1/2	1 1/4	6 3/8	11/16	5/8	3 11/16	1 5/16	3 5/8	21.6
3 3/16 3 7/16 3 1/2	10 1/4	5 1/8	7 1/8	8 5/8	1 5/16	7 3/8	7/8	3/4	4 1/8	1 13/16	4 1/32	40.0
3 11/16 3 15/16 4	10 7/8	6	7 3/4	9 3/8	2 1/16	8 1/8	27/32	3/4	4 3/4	1 7/16	4 19/32	47

Part numbers are specified by "SFC1100E x 1 15/16" or "SFC1100NE x 1 15/16".

*Dimensions L and M are for non-expansion unit. For expansion type, increase L and M by .098" max.



Spherical Roller Bearings

Spherical Roller Bearings 1000 and 1100 Series

This chart displays the Browning 1000 and 1100 Series Spherical Roller Bearing's load capacity for a given L10 life, speed and shaft size. Values in the table represent loads at ideal conditions. The shaded areas indicate the maximum speed for the MULTI-TRAP® Seal. The maximum speed for the Contact Seal is indicated in the non-shaded areas. For combined load determination, see **THE BEARING SELECTION SECTION**, page 269. Areas designated by “-” exceed maximum speed value.

Match Bore Size

Size	Rating	L10 Hours	REVOLUTIONS PER MINUTE																	
			50	100	150	250	500	750	1000	1500	1750	2000	2500	3000	3500					
1 1/8	16600	5000	4880	4880	4880	4546	3692	3269	2999	2656	2331	2059	1850	1673	1509	1359	1219			
		10000	4880	4860	4304	3692	2999	2656	2436	2157	2059	1979	1850	1752	1673	1509	1359	1219		
		30000	4304	3496	3095	2656	2157	1910	1752	1551	1481	1423	1331	1260	1203	1146	1089	1032		
		50000	3692	2999	2656	2278	1850	1639	1503	1331	1271	1221	1142	1081	1032	975	918	861	804	
		100000	2999	2436	2157	1850	1503	1331	1221	1081	1032	992	927	878	838	789	740	691	642	
1 11/16	17300	5000	2999	6458	5522	4737	3848	3407	3125	2767	2642	2539	2374	2248	2146	2044	1942	1840		
		10000	6458	5065	4485	3848	3125	2767	2539	2248	2146	2062	1929	1826	1743	1650	1557	1464	1371	
		30000	6458	3643	3226	2767	2248	1990	1826	1617	1544	1483	1387	1313	1254	1195	1136	1077	1018	
		50000	4485	3125	2767	2374	1929	1708	1566	1387	1324	1272	1190	1127	1076	1025	974	923	872	821
		100000	3848	2539	2248	1929	1566	1387	1272	1127	1076	1033	967	915	874	833	792	751	710	669
1 15/16	19000	5000	3125	6925	6064	5203	4226	3742	3433	3039	2902	2788	2608	2469	2357	2265	2188	2118	2055	1915
		10000	6925	5563	4926	4226	3433	3039	2788	2469	2357	2265	2118	2005	1915	1844	1777	1714	1651	1588
		30000	6925	4001	3543	3039	2469	2186	2005	1776	1695	1629	1523	1442	1377	1314	1251	1188	1125	1062
		50000	4926	3433	3039	2608	2118	1875	1720	1523	1454	1397	1307	1237	1181	1125	1062	1005	960	915
		100000	4226	2788	2469	2118	1720	1523	1397	1237	1181	1135	1062	1005	960	915	870	825	780	735
2 3/16	22400	5000	3433	7150	7150	6134	4982	4412	4047	3583	3421	3287	3074	2911	2779	2670	2574	2481	2390	2299
		10000	7150	6559	5807	4982	4047	3583	3287	2911	2779	2670	2497	2364	2257	2164	2081	1998	1915	1832
		30000	7150	4717	4177	3583	2911	2577	2364	2093	1999	1920	1796	1700	1623	1546	1469	1392	1315	1238
		50000	5807	4047	3583	3074	2497	2211	2028	1796	1715	1647	1541	1459	1393	1330	1267	1204	1141	1078
		100000	4982	3287	2911	2497	2028	1796	1647	1459	1393	1338	1251	1185	1131	1077	1023	969	915	861
2 7/16	33300	5000	4047	10629	10629	9119	7407	6558	6016	5327	5086	4887	4570	4327	4131	3969	3712	3515	3318	3121
		10000	10629	9750	8633	7407	6016	5327	4887	4327	4131	3969	3712	3515	3318	3121	2924	2727	2530	2333
		30000	10629	7012	6209	5327	4327	3831	3515	3112	2971	2855	2670	2528	2387	2246	2105	1964	1823	1682
		50000	8633	6016	5327	4570	3712	3287	3015	2670	2549	2449	2290	2169	2048	1927	1806	1685	1564	1443
		100000	7407	4887	4327	3712	3015	2670	2449	2169	2071	1989	1860	1761	1662	1563	1464	1365	1266	1167
2 11/16	35500	5000	6016	11331	11331	9721	7896	6992	6413	5679	5422	5209	4872	4613	4404	4231	3957	3747	3547	3347
		10000	11331	10394	9204	7896	6413	5679	5209	4613	4404	4231	3957	3747	3547	3347	3147	2947	2747	2547
		30000	11331	7476	6619	5679	4613	4084	3747	3318	3168	3043	2846	2695	2545	2394	2243	2092	1941	1790
		50000	9204	6413	5679	4872	3957	3504	3214	2846	2718	2611	2442	2312	2181	2050	1919	1788	1657	1526
		100000	7896	5209	4613	3957	3214	2846	2611	2312	2207	2121	1983	1878	1773	1668	1563	1458	1353	1248
3 3/16	56900	5000	6413	20827	18161	15581	12656	11206	10280	9102	8691	8350	7850	7509	7168	6827	6486	6145	5804	5463
		10000	20827	16660	14752	12656	10280	9102	8350	7393	7059	6782	6486	6145	5804	5463	5122	4781	4440	4099
		30000	20827	11982	10610	9102	7393	6547	6005	5317	5077	4878	4680	4481	4282	4083	3884	3685	3486	3287
		50000	14752	10280	9102	7809	6343	5616	5152	4562	4356	4185	3986	3815	3616	3445	3246	3075	2876	2705
		100000	12656	8350	7393	6343	5152	4562	4185	3705	3538	3399	3260	3121	2982	2843	2704	2565	2426	2287
3 11/16	69900	5000	10280	25854	22311	19141	15547	13767	12628	11182	10677	10257	9837	9417	8997	8577	8157	7737	7317	6897
		10000	25854	20466	18122	15547	12628	11182	10257	9083	8672	8332	7912	7492	7072	6652	6232	5812	5392	4972
		30000	25854	14720	13034	11182	9083	8042	7377	6532	6237	5992	5747	5502	5257	5012	4767	4522	4277	4032
		50000	18122	12628	11182	9593	7792	6900	6329	5604	5351	5141	4942	4743	4544	4345	4146	3947	3748	3549
		100000	15547	10257	9083	7792	6329	5604	5141	4552	4346	4176	4006	3836	3666	3496	3326	3156	2986	2816
4 7/16	91700	5000	12628	33386	29269	25110	20396	18060	16567	14567	14067	13567	13067	12567	12067	11567	11067	10567	10067	9567
		10000	33386	26849	23774	20396	16567	14669	13456	12067	11567	11067	10567	10067	9567	9067	8567	8067	7567	7067
		30000	33386	19310	17099	14669	11915	10550	9678	8567	8067	7567	7067	6567	6067	5567	5067	4567	4067	3567
		50000	23774	16567	14669	12585	10222	9051	8303	7456	7067	6567	6067	5567	5067	4567	4067	3567	3067	2567
		100000	20396	13456	11915	10222	8303	7352	6744	6067	5567	5067	4567	4067	3567	3067	2567	2067	1567	1067
4 15/16	123,000	5000	16567	45244	39259	33681	27358	24224	21137	18060	16567	15067	14067	13067	12067	11067	10067	9067	8067	7067
		10000	45244	36013	31889	27358	22221	19676	17137	15067	14067	13067	12067	11067	10067	9067	8067	7067	6067	5067
		30000	45244	25902	22935	19676	15982	14152	12567	11067	10567	10067	9567	9067	8567	8067	7567	7067	6567	6067
		50000	31889	22221	19676	16881	13711	12141	10676	9267	8857	8447	8037	7627	7217	6807	6397	5987	5577	5167
		100000	27358	18049	15982	13711	11137	9662	8267	6867	6457	6047	5637	5227	4817	4407	3997	3587	3177	2767

Spherical Roller Bearings

SPBT22500

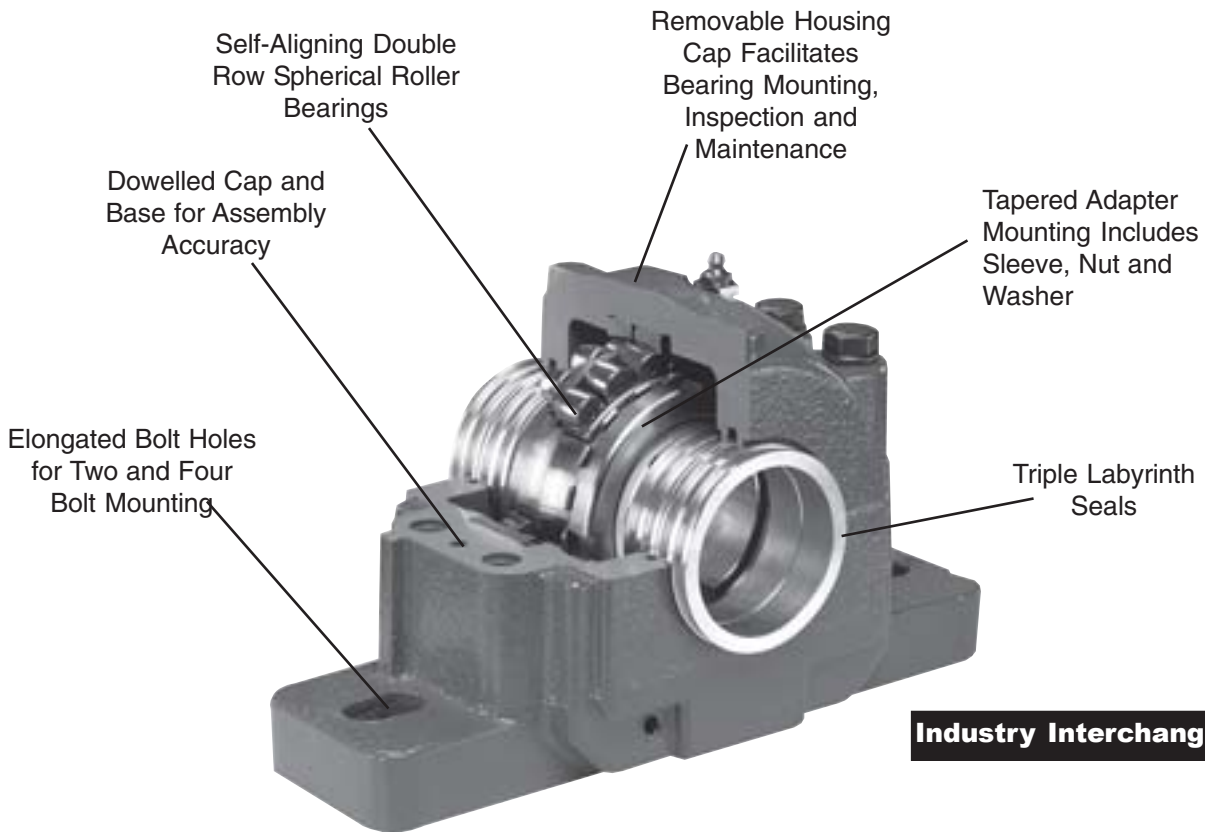

SPBF22200

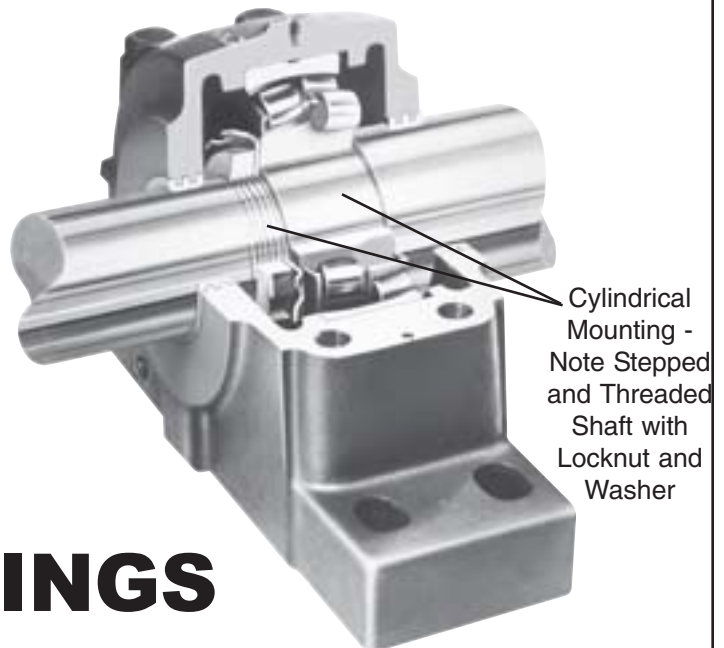

Note: Other features are like the 22500 series

BROWNING 22500/22200 SPHERICAL ROLLER BEARINGS FEATURES/BENEFITS

LOCKING

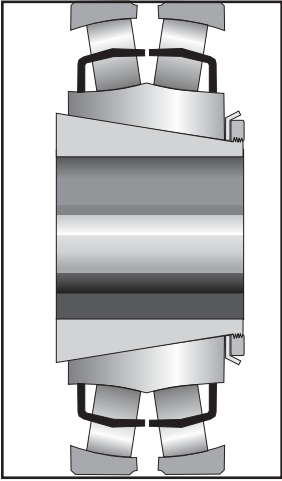

22500 LOCKING

The Browning 22500 series utilizes a tapered adapter system to fasten the bearing to the shaft. The SNW adapter assembly system consists of a sleeve, lock nut and lockwasher that is available from Browning for shaft mounting of tapered bore 22200CKW33C3 spherical roller bearings. This method provides positive shaft lock and conforms to a wide range of shaft tolerances, and maintains concentricity of shaft to bearing bore. The adapter sleeve system does not mar the shaft and reduces fretting corrosion.

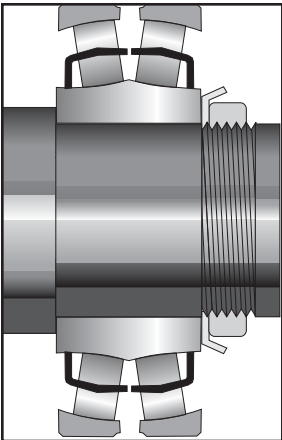

22200 LOCKING

The Browning 22200 cylindrical bore variation requires a press or shrink fit on the shaft. This system requires the user to provide a precise stepped shaft and machined threads for installation of 22200CW33C3 spherical roller bearing inserts.

SEALING

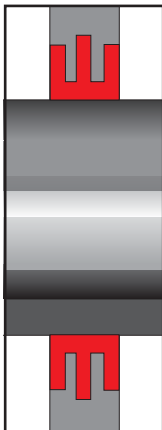

22500/22200 SEALING

Browning 22500/22200 series are available with standard triple labyrinth seals that are manufactured in aluminum. These (LER) type seals are designed with two grooves that mate with the machined grooves in the housing, forming a labyrinth to help keep out contamination. This close clearance seal provides energy efficient operation and lubricant retention characteristics.

BROWNING 22500/22200 SPHERICAL ROLLER BEARINGS FEATURES/BENEFITS

HOUSING

22500/22200 HOUSINGS

Browning 22500 and 22200 series housings are available in cast iron or steel. The 22500 steel and 22200 series pillow blocks are not stocked. These housing styles are provided with a universal sump configuration suitable for grease, oil bath or circulating oil lubrication. Slotted bolt holes in the housing base enable positioning and alignment during installation. A stabilizing ring is furnished with each housing and must be removed for expansion.



GENERAL

This heavy duty line of pillow blocks is designed for typical SAF dimensional interchangeably and generally used in applications where heavier loads are encountered and grease or oil lubrication is desirable. Common applications are found on conveyors in the pulp and paper, mining, aggregate, bulk material handling and steel industries.

TABLE OF CONTENTS

SPBT22500 Pillow Blocks ...	142
SPBF22500 Pillow Blocks ...	143
SPBTS22500 Pillow Blocks	144
SPBFS22500 Pillow Blocks	144
SPBT22200 Pillow Blocks ...	145
SPBF22200 Pillow Blocks ...	145
SPBTS22200 Pillow Blocks	146
SPBFS22200 Pillow Blocks	146
Bearings & Accessories	147

22500 Series

Cast Iron Pillow Blocks

Lock: Adapter Mount
Seal: Triple Labyrinth
Housing: Two Bolt Base
Temperatures: -20°F to 200° F
Self Aligning: See Page 276
Fitting: 1/4NPT for housings 515-528 and 216-228
 3/8NPT for housings 530 and above, and 230 and above
Bearing Insert: 22200 CKW33C3
Accessories: Page 147
Ratings: Page 155
Interchange Tables: Page 166

S SPHERICAL ROLLER
P PILLOW
B BLOCK
T TWO BOLT BASE
2 22500
2 BEARING SERIES
5 ADAPTER MOUNT
0 BEARING
0 SIZE

Expansion and Non-Expansion

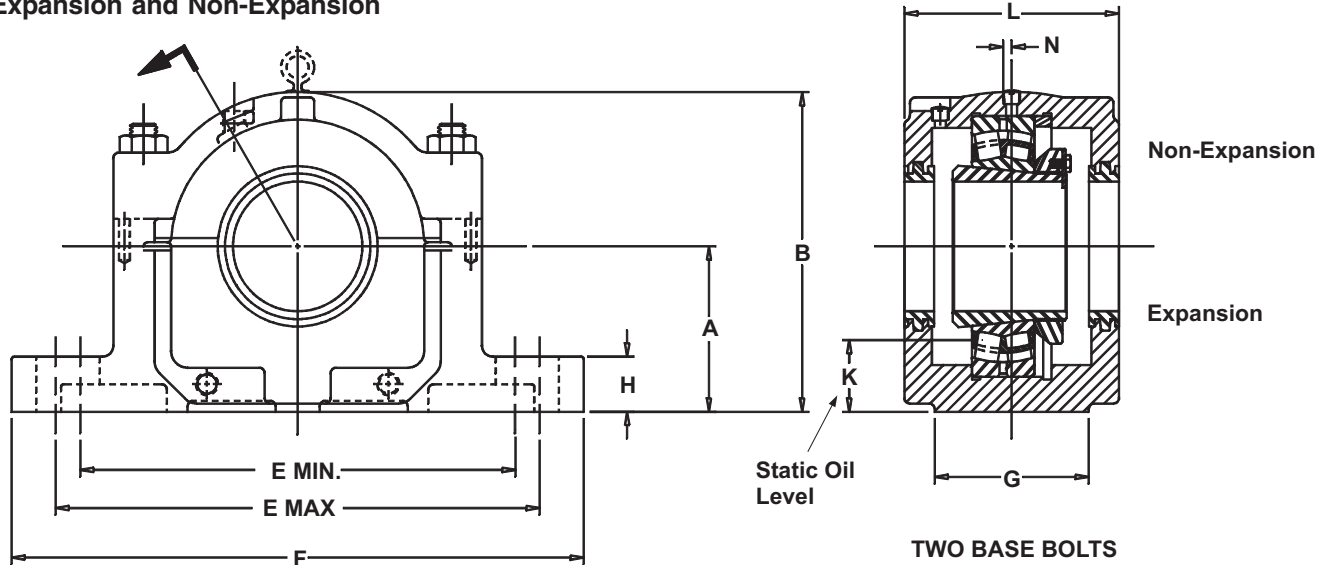

PART NUMBERS					DIMENSIONS IN INCHES													
SHAFT SIZE	(1) Complete Pillow Block	COMPONENTS			A	B	E		F	G	H	K	L	M	N	No.	Size	Wt. Lbs.
		Housing	Seal Rings (2 Req'd.)	Stabilizing Ring (1 Req'd.)			MIN.	MAX.										
TWO BASE BOLT TYPE																		
2 7/16	SPBT22515 X 2 7/16	ST515	SR-207	SR-15	3 1/4	6 3/8	8 5/8	9 5/8	11 1/4	3 1/8	1 1/8	1 1/4	4 3/4	-	1/16	2	5/8	30
2 1/2	SPBT22515 X 2 1/2	ST515	SR208	SR-15	3 1/4	6 9/16	8 5/8	9 5/8	11 1/4	3 1/8	1 1/4	1 1/4	4 3/4	-	1/16	2	5/8	31
2 11/16	SPBT22516 X 2 11/16	ST516	SR-211	SR-16	3 1/2	6 7/8	9 5/8	11	13	3 1/2	1 3/16	1 3/8	4 7/8	-	3/16	2	3/4	37
2 3/4	SPBT22516 X 2 3/4	ST516	SR-212	SR-16	3 1/2	7 1/16	9 5/8	11	13	3 1/2	1 3/8	1 3/8	5 3/8	-	3/16	2	3/4	43
2 15/16	SPBT22517 X 2 15/16	ST517	SR-215	SR-17	3 3/4	7 1/4	9 7/8	11	13	3 1/2	1 1/4	1 1/2	4 15/16	-	3/16	2	3/4	40
3	SPBT22517 X 3	ST517	SR-300	SR-17	3 3/4	7 1/2	9 7/8	11	13	3 1/2	1 7/16	1 1/2	5 3/8	-	3/16	2	3/4	48
3 3/16	SPBT22518 X 3 3/16	ST518	SR-303	SR-18	4	7 3/4	10 3/8	11 5/8	13 3/4	3 7/8	1 1/2	1 5/8	6 1/4	-	3/16	2	3/4	49
3 7/16	SPBT22520 X 3 7/16	ST520	SR-307	SR-20	4 1/2	8 11/16	11 5/8	13 1/8	15 1/4	4 3/8	1 3/4	1 3/4	6	-	3/16	2	7/8	65
3 1/2	SPBT22520 X 3 1/2	ST520	SR-308	SR-20	4 1/2	9	11 5/8	13 1/8	15 1/4	4 3/8	1 3/4	1 3/4	6 1/4	-	3/16	2	7/8	76

(1) This part number includes all components (housing, bearing, seal rings, stabilizing ring, adapter assembly, locknut and lockwasher) which are required to assemble a complete pillow block. Components are packaged separately. Refer to pages 147-148 for bearing and adapter assemblies. A stabilizing ring is furnished with each housing. **DO NOT** use for expansion bearing. **NOTE:** Only one non-expansion bearing should be used on a shaft; all others on the same shaft **MUST** be expansion type. Non-expansion (fixed bearing is offset by "N" amount in relation to center line of housing.

Spherical Roller Bearings



**SPHERICAL ROLLER S
 PILLOW P
 BLOCK B
 FOUR BOLT BASE F**

**22500 2
 BEARING SERIES 2
 ADAPTER MOUNT 5
 BEARING 0
 SIZE 0**

22500 Series

Cast Iron Pillow Blocks

Lock: Adapter Mount
Seal: Triple Labyrinth
Housing: Four Bolt Base
Temperatures: -20°F to 200° F
Self Aligning: See Page 276
Fitting: 1/4NPT for housings 515-528
 and 216-228
 3/8NPT for housings 530 and
 above, and 230 and above

Bearing Insert: 22200 CKW33C3
Accessories: Page 147
Ratings: Page 155
Interchange Tables: Page 166

Expansion and Non-Expansion

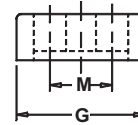
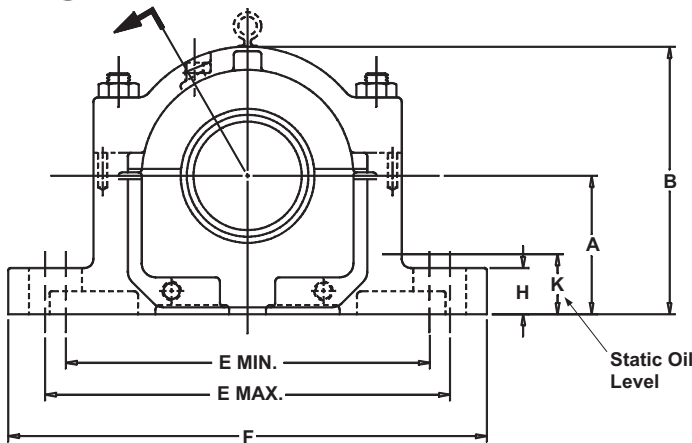

FOUR BASE BOLTS

PART NUMBERS					DIMENSIONS IN INCHES													
SHAFT SIZE	(1) Complete Pillow Block*	COMPONENTS			A	B	E		F	G	H	K	L	M	N	No.	Size	Wt. Lbs.
		Housing	Seal Rings (2 Req'd.)	Stabilizing Ring (1 Req'd.)			MIN.	MAX.										
FOUR BASE BOLT TYPE																		
2 7/16	SPBF22515 X 2 7/16	SF515	SR-207	SR-15	3 1/4	6 3/8	8 5/8	9 5/8	11 1/4	3 1/8	1 1/8	1 1/4	4 3/4	1 7/8	1/16	4	1/2	30
2 1/2	SPBF22515 X 2 1/2	SF515	SR-208	SR-15	3 1/4	6 9/16	8 5/8	9 5/8	11 1/4	3 1/8	1 1/8	1 1/4	4 3/4	1 7/8	1/16	4	1/2	31
2 11/16	SPBF22516 X 2 11/16	SF516	SR-211	SR-16	3 1/2	6 7/8	9 5/8	11	13	3 1/2	1 3/16	1 3/8	4 7/8	2 1/8	3/16	4	5/8	37
2 3/4	SPBF22516 X 2 3/4	SF516	SR-212	SR-16	3 1/2	7 1/16	9 5/8	11	13	3 1/2	1 3/16	1 3/8	5 3/8	2 1/8	3/16	4	5/8	43
2 15/16	SPBF22517 X 2 15/16	SF517	SR-215	SR-17	3 3/4	7 1/4	9 7/8	11	13	3 1/2	1 1/4	1 7/16	4 15/16	2 1/8	3/16	4	5/8	40
3	SPBF22517 X 3	SF517	SR-300	SR-17	3 3/4	7 1/2	9 7/8	11	13	3 1/2	1 1/4	1 1/2	5 3/8	2 1/8	3/16	4	5/8	48
3 3/16	SPBF22518 X 3 3/16	SF518	SR-303	SR-18	4	7 3/4	10 3/8	11 5/8	13 3/4	3 7/8	1 1/2	1 5/8	6 1/4	2 1/8	3/16	4	5/8	49
3 7/16	SPBF22520 X 3 7/16	SF520	SR-307	SR-20	4 1/2	8 11/16	11 5/8	13 1/8	15 1/4	4 3/8	1 11/16	1 3/4	6	2 3/8	3/16	4	3/4	65
3 1/2	SPBF22520 X 3 1/2	SF520	SR-308	SR-20	4 1/2	9	11 5/8	13 1/8	15 1/4	4 3/8	1 11/16	1 3/4	6 1/4	2 3/8	3/16	4	3/4	76
3 11/16	SPBF22522 X 3 11/16	SF522	SR-311	SR-22	4 15/16	9 7/8	12 5/8	14 1/2	16 1/2	4 3/4	2	2	6 1/2	2 3/4	3/16	4	3/4	95
3 15/16	SPBF22522 X 3 15/16	SF522	SR-315	SR-22	4 15/16	9 9/16	12 5/8	14 1/2	16 1/2	4 3/4	2	2	6 3/8	2 3/4	3/16	4	3/4	81
4	SPBF22522 X 4	SF522	SR-400	SR-22	4 15/16	9 7/8	12 5/8	14 1/2	16 1/2	4 3/4	2	2	6 1/2	2 3/4	3/16	4	3/4	95
4 3/16	SPBF22524 X 4 3/16	SF524	SR-403	SR-24	5 1/4	10 1/4	13 1/4	14 1/2	16 1/2	4 3/4	2 1/8	2	7 3/8	2 3/4	3/16	4	3/4	94
4 7/16	SPBF22526 X 4 7/16	SF526	SR-407	SR-26	6	11 9/16	14 5/8	16	18 3/8	5 1/8	2 3/8	2 1/2	8	3 1/4	3/16	4	7/8	137
4 1/2	SPBF22526 X 4 1/2	SF526	SR-408	SR-26	6	11 3/4	14 5/8	16	18 3/8	5 1/8	2 3/8	2 1/2	8	3 1/4	3/16	4	7/8	160
4 15/16	SPBF22528 X 4 15/16	SF528	SR-415	SR-28	6	11 3/4	16	17 1/8	20 1/8	5 7/8	2 3/8	2 1/4	7 3/4	3 3/8	3/16	4	1	159
5	SPBF22528 X 5	SF528	SR-500	SR-28	6	12	16	17 1/8	20 1/8	5 7/8	2 3/8	2 1/4	7 1/2	3 3/8	3/16	4	1	170
5 3/16	SPBF22530 X 5 3/16	SF530	SR-503	SR-30	6 5/16	12 1/2	17	18 1/4	21 1/4	6 1/4	2 1/2	2 1/2	8 3/8	3 3/4	3/16	4	1	189
5 7/16	SPBF22532 X 5 7/16	SF532	SR-507	SR-32	6 11/16	13 5/16	17 3/8	19 1/4	22	6 1/4	2 5/8	1 7/8	8 3/4	3 3/4	3/16	4	1	225
5 1/2	SPBF22532 X 5 1/2	SF532	SR-508	SR-32	6 11/16	13 5/8	17 3/8	19 1/4	22	6 1/4	2 5/8	1 7/8	8 3/4	3 3/4	3/16	4	1	225
5 15/16	SPBF22534 X 5 15/16	SF534	SR-515	SR-34	7 1/16	14 9/16	19 3/8	21 5/8	24 3/4	6 3/4	2 3/4	2	9 3/8	4 1/4	3/16	4	1	300
6	SPBF22534 X 6	SF534	SR-600	SR-34	7 1/16	14 1/2	19 3/8	21 5/8	24 3/4	6 3/4	2 3/4	2	9 5/8	4 1/4	3/16	4	1	300
6 7/16	SPBF22536 X 6 7/16	SF536	SR-607	SR-36	7 1/2	15 1/2	20 7/8	23 5/8	26 3/4	7 1/8	3	2 3/8	9 11/16	4 5/8	3/16	4	1	330
6 1/2	SPBF22536 X 6 1/2	SF536	SR-608	SR-36	7 1/2	15 1/4	20 7/8	23 5/8	26 3/4	7 1/8	3	2 3/8	10	4 5/8	3/16	4	1	355
6 15/16	SPBF22538 X 6 15/16	SF538	SR-615	SR-38	7 7/8	15 11/16	21 5/8	24 3/8	28	7 1/2	3 1/8	2 3/8	10 3/4	4 1/2	3/16	4	1 1/4	375
7	SPBF22538 X 7	SF538	SR-700	SR-38	7 7/8	16 1/8	21 5/8	24 3/8	28	7 1/2	3 1/8	2 3/8	10 3/4	4 1/2	3/16	4	1 1/4	415
7 3/16	SPBF22540 X 7 3/16	SF540	SR-703	SR-40	8 1/4	17 3/16	22 1/2	25	29 1/2	8	3 3/8	2 5/8	10 13/16	5	3/16	4	1 1/4	445
7 1/2	SPBF22544 X 7 1/2	SF544	SR-708	SR-44	9 1/2	19 3/8	24 3/4	27 7/8	32 3/4	8 3/4	3 3/4	2 1/2	12	5 1/4	3/16	4	1 1/2	685
7 15/16	SPBF22544 X 7 15/16	SF544	SR-715	SR-44	9 1/2	19 5/8	24 3/4	27 7/8	32 3/4	8 3/4	3 3/4	2 1/2	11 1/2	5 1/4	3/16	4	1 1/2	615
8	SPBF22544 X 8	SF544	SR-800	SR-44	9 1/2	19 3/8	24 3/4	27 7/8	32 3/4	8 3/4	3 3/4	2 1/2	12	5 1/4	3/16	4	1 1/2	685

Browning®

Spherical Roller Bearings

22500 Series

Cast Steel Pillow Blocks

- Lock: Adapter Mount
- Seal: Triple Labyrinth
- Housing: Cast Steel
- Temperatures: -20° to 200° F
- Self Aligning: See Page 276
- Fitting: 1/4NPT for housings 515-528 and 216-228
3/8NPT for housings 530 and above, and 230 and above
- Bearing Insert: 22200 CKW33C3
- Accessories: Page 147
- Ratings: Page 155
- Interchange Tables: Page 166

- S SPHERICAL ROLLER**
- P PILLOW**
- B BLOCK**
- T TWO BOLT BASE**
- (F FOUR BOLT BASE)**
- S CAST STEEL HOUSING**

- 2 22500**
- 2 BEARING SERIES**
- 5 ADAPTER MOUNT**
- 0 BEARING**
- 0 SIZE**



Expansion and Non-Expansion

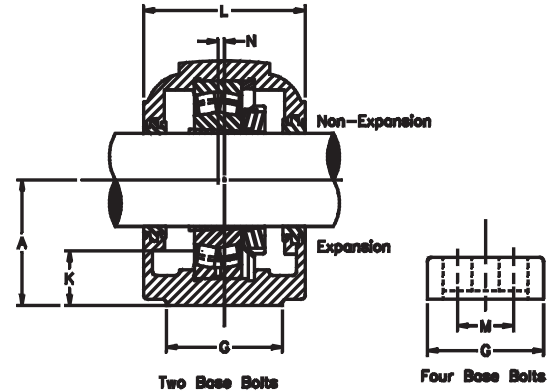
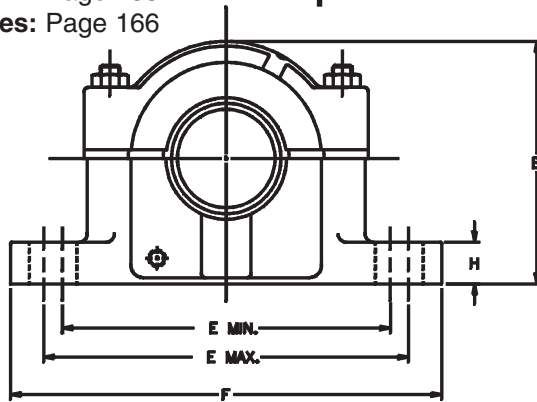

PART NUMBERS			DIMENSIONS IN INCHES												
SHAFT SIZE	(1) Complete Pillow Block*	Housing	A	B	E		F	G	H	K	L	M	N	Size	Wt. Lbs.
					MIN.	MAX.									
TWO BASE BOLT TYPE															
2 7/16	SPBTS22515 X 2 7/16	STS515	3 1/4	6 3/8	8 5/8	9 5/8	11 1/4	3 1/8	1 1/8	1 1/4	4 3/4	-	3/16	5/8	30
2 11/16	SPBTS22516 X 2 11/16	STS516	3 1/2	6 7/8	9 5/8	11	13	3 1/2	1 3/16	1 11/16	4 7/8	-	3/16	3/4	37
2 15/16	SPBTS22517 X 2 15/16	STS517	3 3/4	7 1/4	9 7/8	11	13	3 1/2	1 1/4	1 7/16	4 15/16	-	3/16	3/4	40
3 3/16	SPBTS22518 X 3 3/16	STS518	4	7 3/4	10 3/4	11 5/8	13 3/4	3 7/8	1 1/2	1 17/32	6 1/4	-	3/16	3/4	49
3 7/16	SPBTS22520 X 3 7/16	STS520	4 1/2	8 11/16	11 5/8	13 1/8	15 1/4	4 3/8	1 3/4	1 3/4	6	-	3/16	7/8	65
FOUR BASE BOLT TYPE															
2 7/16	SPBFS22515 X 2 7/16	SFS15	3 1/4	6 3/8	8 5/8	9 5/8	11 1/4	3 1/8	1 1/8	1 1/4	4 3/4	1 7/8	3/16	1/2	30
2 11/16	SPBFS22516 X 2 11/16	SFS516	3 1/2	6 7/8	9 5/8	11	13	3 1/2	1 3/16	1 11/32	4 7/8	2 1/8	3/16	5/8	37
2 15/16	SPBFS22517 X 2 15/16	SFS517	3 3/4	7 1/4	9 7/8	11	13	3 1/2	1 1/4	1 7/16	4 15/16	2 1/8	3/16	5/8	40
3 3/16	SPBFS22518 X 3 3/16	SFS518	4	7 3/4	10 3/8	11 5/8	13 3/4	3 7/8	1 1/2	1 17/32	6 1/4	2 1/8	3/16	5/8	65
3 7/16	SPBFS22520 X 3 7/16	SFS520	4 1/2	8 11/16	11 5/8	13 1/8	15 1/4	4 3/8	1 3/4	1 3/4	6	2 3/8	3/16	3/4	65
3 15/16	SPBFS22522 X 3 15/16	SFS522	4 15/16	9 9/16	12 5/8	14 1/2	16 1/2	4 3/4	2	1 7/8	6 3/8	2 3/4	3/16	3/4	81
4 3/16	SPBFS22524 X 4 3/16	SFS524	5 1/4	10 1/4	13 1/4	14 1/2	16 1/2	4 3/4	2 1/8	1 15/16	7 3/8	2 3/4	3/16	3/4	94
4 7/16	SPBFS22526 X 4 7/16	SFS526	6	11 9/16	14 5/8	16	18 3/8	5 1/8	2 3/8	2 7/16	8	3 1/4	3/16	7/8	137
4 15/16	SPBFS22528 X 4 15/16	SFS528	6	11 3/4	16	17 1/8	20 1/8	5 7/8	2 3/8	2 1/8	7 3/4	3 3/8	3/16	1	159
5 3/16	SPBFS22530 X 5 3/16	SFS530	6 5/16	12 1/2	17	18 1/4	21 1/4	6 1/4	2 1/2	2 3/16	8 3/8	3 3/4	3/16	1	189
5 7/16	SPBFS22532 X 5 7/16	SFS532	6 11/16	13 5/16	17 3/8	19 1/4	22	6 1/4	2 5/8	2 3/16	8 3/4	3 3/4	3/16	1	225
5 15/16	SPBFS22534 X 5 15/16	SFS534	7 1/16	14 9/16	19 3/8	21 5/8	24 3/4	6 3/4	2 3/4	2 5/16	9 3/8	4 1/4	3/16	1	300
6 7/16	SPBFS22536 X 6 7/16	SFS536	7 1/2	15 1/2	20 7/8	23 5/8	26 3/4	7 1/8	3	2 9/16	9 11/16	4 5/8	3/16	1	330
6 15/16	SPBFS22538 X 6 15/16	SFS538	7 7/8	15 11/16	21 5/8	24 3/8	28	7 1/2	3 1/8	2 5/8	10 3/4	4 1/2	3/16	1 1/4	375
7 3/16	SPBFS22540 X 7 3/16	SFS540	8 1/4	17 3/16	22 1/2	25	29 1/2	8	3 3/8	2 11/16	10 13/16	5	3/16	1 1/4	445
7 15/16	SPBFS22544 X 7 15/16	SFS544	9 1/2	19 5/8	24 3/4	27 7/8	32 3/4	8 3/4	3 3/4	3 3/8	11 1/2	5 1/4	3/16	1 1/2	615

*Not available from stock - Contact Browning for delivery.

(1) This part number includes all components (housing, bearing, seal rings, stabilizing ring, adapter assembly, locknut and lockwasher) which are required to assemble a complete pillow block. Components are packaged separately.

Refer to pages 147-148 for bearing and adapter assemblies.

A stabilizing ring is furnished with each housing. **DO NOT** use for expansion bearing. **NOTE:** Only one non-expansion bearing should be used on a shaft; all others on the same shaft **MUST** be expansion type.

Non-expansion (fixed bearing is offset by "N" amount in relation to center line of housing.

Spherical Roller Bearings

22200 Series



SPHERICAL ROLLER S
PILLOW P
BLOCK B
TWO BOLT BASE T
FOUR BOLT BASE (F)

22000 2
BEARING SERIES 2
CYLINDRICAL MOUNT 2
BEARING 0
SIZE 0

Cast Iron Pillow Blocks

Lock: Cylindrical Mount
Seal: Triple Labyrinth
Housing: Cast Iron
Temperatures: -20°F to 200°F
Self Aligning: See Page 276
Fitting: 1/4NPT for housings 515-528 and 216-228
3/8NPT for housings 530 and above, and 230 and above
Bearing Insert: 22200 CW33C3
Accessories: Page 147
Ratings: Page 155
Interchange Tables: Page 166
Expansion and Non-Expansion

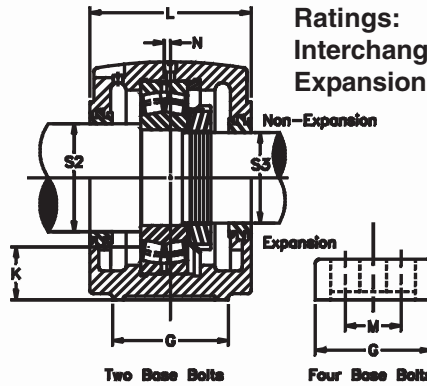
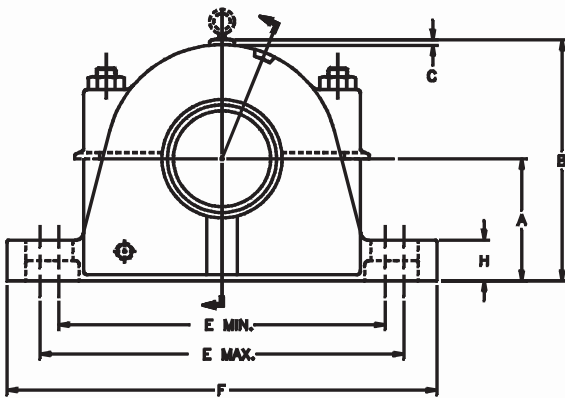

PART NUMBERS			DIMENSIONS IN INCHES												
SHAFT SIZE	(1) Complete Pillow Block*	Housing	A	B	E		F	G	H	K	L	M	N	Size	Wt. Lbs.
					MIN.	MAX.									
TWO BASE BOLT TYPE															
2 7/16	SPBTS22515 X 2 7/16	STS515	3 1/4	6 3/8	8 5/8	9 5/8	11 1/4	3 1/8	1 1/8	1 1/4	4 3/4	-	3/16	5/8	30
2 11/16	SPBTS22516 X 2 11/16	STS516	3 1/2	6 7/8	9 5/8	11	13	3 1/2	1 3/16	1 11/16	4 7/8	-	3/16	3/4	37
2 15/16	SPBTS22517 X 2 15/16	STS517	3 3/4	7 1/4	9 7/8	11	13	3 1/2	1 1/4	1 7/16	4 15/16	-	3/16	3/4	40
3 3/16	SPBTS22518 X 3 3/16	STS518	4	7 3/4	10 3/4	11 5/8	13 3/4	3 7/8	1 1/2	1 17/32	6 1/4	-	3/16	3/4	49
3 7/16	SPBTS22520 X 3 7/16	STS520	4 1/2	8 11/16	11 5/8	13 1/8	15 1/4	4 3/8	1 3/4	1 3/4	6	-	3/16	7/8	65
FOUR BASE BOLT TYPE															
2 7/16	SPBFS22515 X 2 7/16	SFS15	3 1/4	6 3/8	8 5/8	9 5/8	11 1/4	3 1/8	1 1/8	1 1/4	4 3/4	1 7/8	3/16	1/2	30
2 11/16	SPBFS22516 X 2 11/16	SFS516	3 1/2	6 7/8	9 5/8	11	13	3 1/2	1 3/16	1 11/32	4 7/8	2 1/8	3/16	5/8	37
2 15/16	SPBFS22517 X 2 15/16	SFS517	3 3/4	7 1/4	9 7/8	11	13	3 1/2	1 1/4	1 7/16	4 15/16	2 1/8	3/16	5/8	40
3 3/16	SPBFS22518 X 3 3/16	SFS518	4	7 3/4	10 3/8	11 5/8	13 3/4	3 7/8	1 1/2	1 17/32	6 1/4	2 1/8	3/16	5/8	65
3 7/16	SPBFS22520 X 3 7/16	SFS520	4 1/2	8 11/16	11 5/8	13 1/8	15 1/4	4 3/8	1 3/4	1 3/4	6	2 3/8	3/16	3/4	65
3 15/16	SPBFS22522 X 3 15/16	SFS522	4 15/16	9 9/16	12 5/8	14 1/2	16 1/2	4 3/4	2	1 7/8	6 3/8	2 3/4	3/16	3/4	81
4 3/16	SPBFS22524 X 4 3/16	SFS524	5 1/4	10 1/4	13 1/4	14 1/2	16 1/2	4 3/4	2 1/8	1 15/16	7 3/8	2 3/4	3/16	3/4	94
4 7/16	SPBFS22526 X 4 7/16	SFS526	6	11 9/16	14 5/8	16	18 3/8	5 1/8	2 3/8	2 7/16	8	3 1/4	3/16	7/8	137
4 15/16	SPBFS22528 X 4 15/16	SFS528	6	11 3/4	16	17 1/8	20 1/8	5 7/8	2 3/8	2 1/8	7 3/4	3 3/8	3/16	1	159
5 3/16	SPBFS22530 X 5 3/16	SFS530	6 5/16	12 1/2	17	18 1/4	21 1/4	6 1/4	2 1/2	2 3/16	8 3/8	3 3/4	3/16	1	189
5 7/16	SPBFS22532 X 5 7/16	SFS532	6 11/16	13 5/16	17 3/8	19 1/4	22	6 1/4	2 5/8	2 3/16	8 3/4	3 3/4	3/16	1	225
5 15/16	SPBFS22534 X 5 15/16	SFS534	7 1/16	14 9/16	19 3/8	21 5/8	24 3/4	6 3/4	2 3/4	2 5/16	9 3/8	4 1/4	3/16	1	300
6 7/16	SPBFS22536 X 6 7/16	SFS536	7 1/2	15 1/2	20 7/8	23 5/8	26 3/4	7 1/8	3	2 9/16	9 11/16	4 5/8	3/16	1	330
6 15/16	SPBFS22538 X 6 15/16	SFS538	7 7/8	15 11/16	21 5/8	24 3/8	28	7 1/2	3 1/8	2 5/8	10 3/4	4 1/2	3/16	1 1/4	375
7 3/16	SPBFS22540 X 7 3/16	SFS540	8 1/4	17 3/16	22 1/2	25	29 1/2	8	3 3/8	2 11/16	10 13/16	5	3/16	1 1/4	445
7 15/16	SPBFS22544 X 7 15/16	SFS544	9 1/2	19 5/8	24 3/4	27 7/8	32 3/4	8 3/4	3 3/4	3 3/8	11 1/2	5 1/4	3/16	1 1/2	615

*Not available from stock - Contact Browning for delivery.

(1) This part number includes all components (housing, bearing, seal rings, stabilizing ring, adapter assembly, locknut and lockwasher) which are required to assemble a complete pillow block. Components are packaged separately.

Refer to pages 149-150 for bearing and adapter assemblies.

A stabilizing ring is furnished with each housing. **DO NOT** use for expansion bearing. **NOTE:** Only one non-expansion bearing should be used on a shaft; all others on the same shaft **MUST** be expansion type.

Non-expansion (fixed bearing is offset by "N" amount in relation to center line of housing.

22200 Series

Cast Steel Pillow Blocks

Lock: Cylindrical Mount
Seal: Triple Labyrinth
Housing: Cast Steel
Temperatures: - 20°F to 200°F
Self Aligning: See Page 276
Fitting: 1/4NPT for housings 515-528 and 216-228
 3/8NPT for housings 530 and above, and 230 and above

Bearing Insert: 22200 CW33C3

Accessories: Page 149

Ratings: Page 155

Interchange Tables: Page 166

Expansion and Non-Expansion

- S SPHERICAL ROLLER**
 - P PILLOW**
 - B BLOCK**
 - T TWO BOLT BASE**
 - (F) FOUR BOLT BASE**
 - S CAST STEEL HOUSING**
-
- 2 22200**
 - 2 BEARING SERIES**
 - 2 CYLINDRICAL MOUNT**
 - 0 BEARING**
 - 0 SIZE**

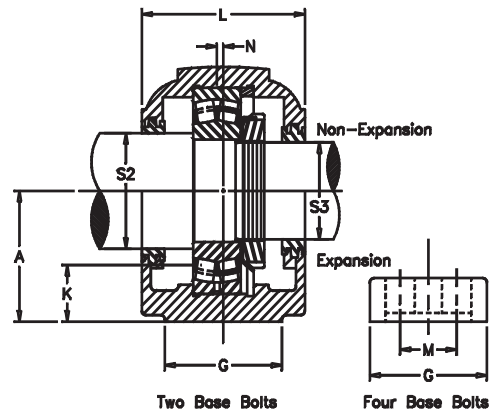
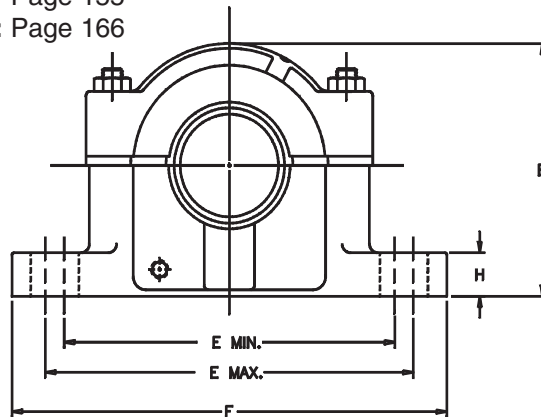

SHAFT SIZE		DIMENSIONS IN INCHES														
S2	S3	(1) Complete Pillow Block*	Housing only with Stabilizing Ring	A	B	E		F	G	H	K	L	M	N	Bolt Size	Wt. Lbs.
						MIN.	MAX.									
TWO BASE BOLT TYPE																
3 5/8	3	SPBTS22216	STS216	3 1/2	6 7/8	9 5/8	11	13	3 1/2	1 3/8	1 11/32	4 7/8	-	3/16	3/4	33
3 15/16	3 3/16	SPBTS22217	STS217	3 3/4	7 1/4	9 7/8	11	13	3 1/2	1 1/4	1 7/16	4 15/16	-	3/16	3/4	43
4 1/8	3 3/8	SPBTS22218	STS218	4	7 3/4	10 3/8	11 5/8	13 3/4	3 7/8	1 1/2	1 17/32	6 1/4	-	3/16	3/4	50
4 1/2	3 13/16	SPBTS22220	STS220	4 1/2	8 11/16	11 5/8	13 1/8	15 1/4	4 3/8	1 3/4	1 3/4	6	-	3/16	7/8	71
FOUR BASE BOLT TYPE																
3 5/8	3	SPBFS22216	SFS216	3 1/2	6 7/8	9 5/8	11	13	3 1/2	3 3/8	1 11/32	4 7/8	2 1/8	3/16	5/8	33
3 15/16	3 3/16	SPBFS22217	SFS217	3 3/4	7 1/4	9 7/8	11	13	3 1/2	1 1/4	1 7/16	4 15/16	2 1/8	3/16	5/8	43
4 1/8	3 3/8	SPBFS22218	SFS218	4	7 3/4	10 3/8	11 5/8	13 3/4	3 7/8	1 1/2	1 17/32	6 1/4	2 1/8	3/16	5/8	50
4 1/2	3 13/16	SPBFS22220	SFS220	4 1/2	8 11/16	11 5/8	13 1/8	15 1/4	4 3/8	1 3/4	1 3/4	6	2 3/8	3/16	3/4	71
4 7/8	4 3/16	SPBFS22222	SFS222	4 15/16	9 9/16	12 5/8	14 1/2	16 1/2	4 3/4	2	1 7/8	6 3/8	2 3/4	3/16	3/4	81
5 5/16	4 9/16	SPBFS22224	SFS224	5 1/4	10 1/4	13 1/4	14 1/2	16 1/2	4 3/4	2 1/8	1 15/16	7 3/8	2 3/4	3/16	3/4	90
5 7/8	4 15/16	SPBFS22226	SFS226	6	11 9/16	14 5/8	16	18 3/8	5 1/8	2 3/8	2 7/16	8	3 1/4	3/16	7/8	127
6 1/4	5 5/16	SPBFS22228	SFS228	6	11 3/4	16	17 1/8	20 1/8	5 7/8	2 3/8	2 1/8	7 3/4	3 3/8	3/16	1	149
6 5/8	5 3/4	SPBFS22230	SFS230	6 5/16	12 1/2	17	18 1/4	21 1/4	6 1/4	2 1/2	2 3/16	8 3/8	3 3/4	3/16	1	175
7	6 1/16	SPBFS22232	SFS232	6 11/16	13 5/16	17 3/8	19 1/4	22	6 1/4	2 5/8	2 3/16	8 3/4	3 3/4	3/16	1	210
7 7/16	6 7/16	SPBFS22234	SFS234	7 1/16	14 9/16	19 3/8	21 5/8	24 3/4	6 3/4	2 3/4	2 5/16	9 3/8	4 1/4	3/16	1	280
7 13/16	6 7/8	SPBFS22236	SFS236	7 1/2	15 1/2	20 7/8	23 5/8	26 3/4	7 1/8	3	2 9/16	9 11/16	4 5/8	3/16	1	305
8 3/8	7 1/4	SPBFS22238	SFS238	7 7/8	15 11/16	21 5/8	24 3/8	28	7 1/2	3 1/8	2 5/8	10 3/4	4 1/2	3/16	1 1/4	350
8 3/4	7 5/8	SPBFS22240	SFS240	8 1/4	17 3/16	22 1/2	25	29 1/2	8	3 3/8	2 11/16	10 13/16	5	3/16	1 1/4	420
9 9/16	8 5/16	SPBFS22244	SFS244	9 1/2	19 5/8	24 3/4	27 7/8	32 3/4	8 3/4	3 3/4	3 3/8	11 1/2	5 1/4	3/16	1 1/2	590

*Not available from stock - Contact Browning for delivery.

(1) This part number includes all components (housing, bearing, seal rings, stabilizing ring, adapter assembly, locknut and lockwasher) which are required to assemble a complete pillow block. Components are packaged separately. Refer to pages 149-150 for bearing and adapter assemblies.

A stabilizing ring is furnished with each housing. **DO NOT** use for expansion bearing. **NOTE:** Only one non-expansion bearing should be used on a shaft; all others on the same shaft **MUST** be expansion type.

Non-expansion (fixed bearing is offset by "N" amount in relation to center line of housing.

22200 Adapter Mount Bearings



22200 SERIES 2
ADAPTER 2
MOUNT 2
BEARINGS 0
0

CENTER GUIDANCE C
1-12 TAPER K
LUBE W
HOLES 3
AND GROOVE 3
ABMA C
INTERNAL CLEARANCE 3

22200CKW33C3

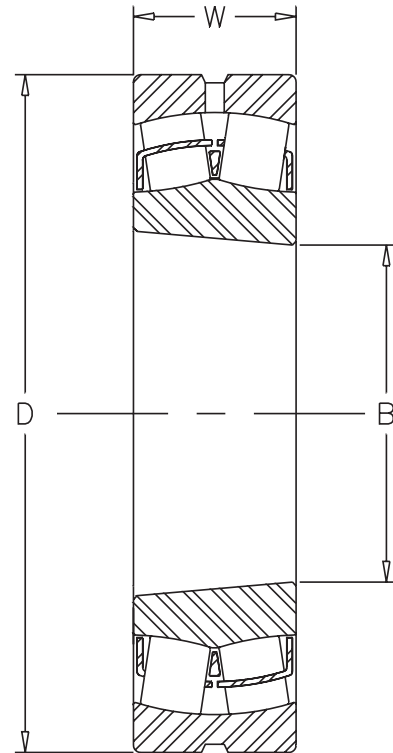

Shaft Size	Bearing Part Number	B		D		W		Wt. Lbs.
		mm	inches	mm	inches	mm	inches	
2 7/16	22215CKW33C3	75	2.9528	130	5.1181	31	1.2205	3.9
2 1/2	22215CKW33C3	75	2.9528	130	5.1181	31	1.2205	3.9
2 11/16	22216CKW33C3	80	3.1496	140	5.5118	33	1.2992	4.6
2 3/4	22216CKW33C3	80	3.1496	140	5.5118	33	1.2992	4.6
2 15/16	22217CKW33C3	85	3.3465	150	5.9055	36	1.4173	5.9
3	22217CKW33C3	85	3.3465	150	5.9055	36	1.4173	5.9
3 3/16	22218CKW33C3	90	3.5433	160	6.2992	40	1.5748	7.5
3 7/16	22220CKW33C3	100	3.9370	180	7.0866	46	1.8110	11.1
3 1/2	22220CKW33C3	100	3.9370	180	7.0866	46	1.8110	11.1
3 11/16	22222CKW33C3	110	4.3307	200	7.8740	53	2.0866	15.9
3 15/16	22222CKW33C3	110	4.3307	200	7.8740	53	2.0866	15.9
4	22222CKW33C3	110	4.3307	200	7.8740	53	2.0866	15.9
4 3/16	22224CKW33C3	120	4.7244	215	8.4646	58	2.2835	19.8
4 7/16	22226CKW33C3	130	5.1181	230	9.0551	64	2.5197	24.8
4 1/2	22226CKW33C3	130	5.1181	230	9.0551	64	2.5197	24.8
4 15/16	22228CKW33C3	140	5.5118	250	9.8425	68	2.6772	31.3
5	22228CKW33C3	140	5.5118	250	9.8425	68	2.6772	31.3
5 3/16	22230CKW33C3	150	5.9055	270	10.6299	73	2.8740	39.5
5 7/16	22232CKW33C3	160	6.2992	290	11.4173	80	3.1496	50.2
5 1/2	22232CKW33C3	160	6.2992	290	11.4173	80	3.1496	50.2
5 15/16	22234CKW33C3	170	6.6929	310	12.2047	86	3.3858	62.0
6	22234CKW33C3	170	6.6929	310	12.2047	86	3.3858	62.0
6 7/16	22236CKW33C3	180	7.0866	320	12.5984	86	3.3858	64.8
6 1/2	22236CKW33C3	180	7.0866	320	12.5984	86	3.3858	64.8
6 15/16	22238CKW33C3	190	7.4803	340	13.3858	92	3.6220	78.5
7	22238CKW33C3	190	7.4803	340	13.3858	92	3.6220	78.5
7 3/16	22240CKW33C3	200	7.8740	360	14.1732	98	3.8583	94.0
7 1/2	22244CKW33C3	220	8.6614	400	15.7480	108	4.2520	130.0
7 15/16	22244CKW33C3	220	8.6614	400	15.7480	108	4.2520	130.0
8	22244CKW33C3	220	8.6614	400	15.7480	108	4.2520	130.0

SNW

S SLEEVE
N NUT
W WASHER

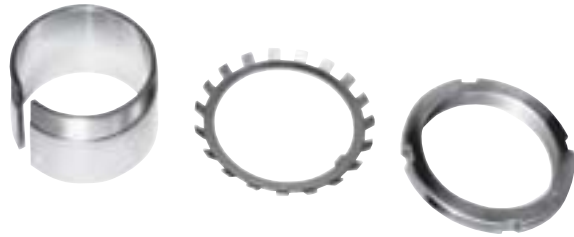
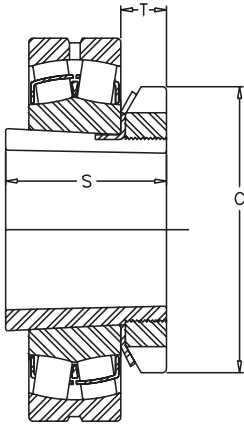

Shaft Size*	Adapter Part Number	C	S	T	Wt. Lbs.
2 7/16	SNW15 X 2 7/16	3 7/8	2.296	43/64	2.3
2 1/2	SNW15 X 2 1/2	3 7/8	2.296	43/64	2.2
2 11/16	SNW16 X 2 11/16	4 5/32	2.376	43/64	2.4
2 3/4	SNW16 X 2 3/4	4 5/32	2.376	43/64	2.3
2 15/16	SNW17 X 2 15/16	4 13/32	2.486	45/64	2.9
3	SNW17 X 3	4 13/32	2.486	45/64	2.8
3 3/16	SNW18 X 3 3/16	4 21/32	2.646	25/32	3.1
3 7/16	SNW20 X 3 7/16	5 3/16	2.869	27/32	4.4
3 1/2	SNW20 X 3 1/2	5 3/16	2.869	27/32	4.2
3 11/16	SNW22 X 3 11/16	5 23/32	3.206	29/32	5.0
3 15/16	SNW22 X 3 15/16	5 23/32	3.206	29/32	4.8
4	SNW22 X 4	5 23/32	3.206	29/32	4.7
4 3/16	SNW24 X 4 3/16	6 1/8	3.466	15/16	6.7
4 7/16	SNW26 X 4 7/16	6 3/4	3.762	1	9.7
4 1/2	SNW26 X 4 1/2	6 3/4	3.762	1	9.5
4 15/16	SNW28 X 4 15/16	7 3/32	3.981	1 1/16	10.3
5	SNW28 X 5	7 3/32	3.981	1 1/16	10.1
5 3/16	SNW30 X 5 3/16	7 11/16	4.241	1 1/8	15.8
5 7/16	SNW32 X 5 7/16	8 1/16	4.578	1 3/16	15.6
5 1/2	SNW32 X 5 1/2	8 1/16	4.578	1 3/16	15.4
5 15/16	SNW34 X 5 15/16	8 21/32	4.847	1 7/32	19.4
6	SNW34 X 6	8 21/32	4.847	1 7/32	19.2
6 7/16	SNW36 X 6 7/16	9 1/16	5.038	1 1/4	20.5
6 1/2	SNW36 X 6 1/2	9 1/16	5.038	1 1/4	20.2
6 15/16	SNW38 X 6 15/16	9 15/32	5.261	1 9/32	23.4
7	SNW38 X 7	9 15/32	5.261	1 9/32	23.2
7 3/16	SNW40 X 7 3/16	9 27/32	5.484	1 11/32	30.7
7 1/2	SNW44 X 7 1/2	11	5.901	1 13/32	33.0
7 15/16	SNW44 X 7 15/16	11	5.901	1 13/32	32.3
8	SNW44 X 8	11	5.901	1 13/32	32.0

*Recommended shaft tolerances for adapter mounting:
 2 7/16" +.000, -.003 4" - 6" +.000, -.005
 2 1/2" - 4 incl. +.000, -.004 6" - 8" incl. +.000, -.006

22200 Cylindrical Bore Bearings

22200CW33C3

22200 2
SERIES 2
CYLINDRICAL 2
MOUNT 0
BEARING 0

CENTER GUIDANCE C
LUBE HOLES W
AND 3
GROOVE 3
ABMA C
INTERNAL CLEARANCE 3

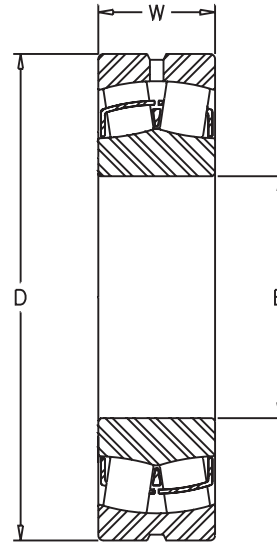

CYLINDRICAL BORE BEARINGS - 222 SERIES									
SHAFT SIZE		BEARING PART NO.	B		D		W		Wt. Lbs.
S2	S3		MM	INCHES	MM	INCHES	MM	INCHES	
3 5/8	3	22216CW33C3	80	3.1496	140	5.5118	33	1.2992	4.5
3 15/16	3 3/16	22217CW33C3	85	3.3465	150	5.9055	36	1.4173	5.6
4 1/8	3 3/8	22218CW33C3	90	3.5433	160	6.2992	40	1.5748	7.2
4 1/2	3 13/16	22220CW33C3	100	3.9370	180	7.0866	46	1.8110	10.5
4 7/8	4 3/16	22222CW33C3	110	4.3307	200	7.8740	53	2.0866	15.5
5 5/16	4 9/16	22224CW33C3	120	4.7244	215	8.4646	58	2.2835	19
5 7/8	4 15/16	22226CW33C3	130	5.1181	230	9.0551	64	2.5197	24.5
6 1/4	5 5/16	22228CW33C3	140	5.5118	250	9.8425	68	2.6772	31.0
6 5/8	5 3/4	22230CW33C3	150	5.9055	270	10.6299	73	2.8740	39.5
7	6 1/16	22232CW33C3	160	6.2992	290	11.4173	80	3.1496	49.5
7 7/16	6 7/16	22234CW33C3	170	6.6929	310	12.2047	86	3.3858	63.0
7 13/16	6 7/8	22236CW33C3	180	7.0866	320	12.5984	86	3.3858	65.0
8 3/8	7 1/4	22238CW33C3	190	7.4803	340	13.3858	92	3.6220	80.5
8 3/4	7 5/8	22240CW33C3	200	7.7840	360	14.1732	98	3.8583	96.0
9 9/16	8 5/16	22244CW33C3	220	8.6614	400	15.7480	108	4.2520	135

22200 CYLINDRICAL BORE LOCKNUT/WASHER

ANW

**A PACKAGE OF
N LOCKNUT
W WASHER**

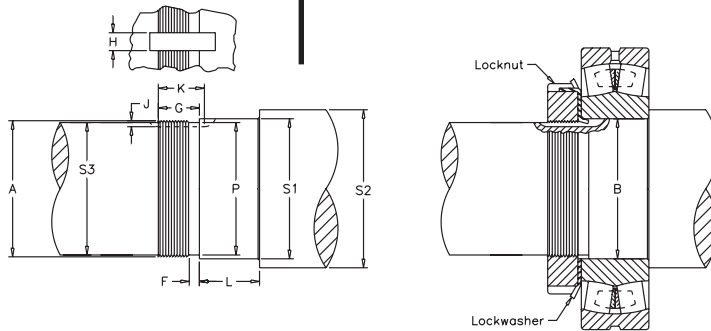

LOCKNUT/LOCKWASHER PACKAGES and SHAFT DIMENSIONS

Bearing Size	Locknut and Lockwasher Package	B Bearing Bore		Keyway			Threads Per Inch	F Thread Relief +1/64" -0"	G Thread Length +1/64" -0"	L Bearing Seat +0" -1/64"	P Thread Relief Dia. +.010"
		MM	INCHES	J Depth +1/64" -0"	H Width +1/64" -0"	K Full Depth Length					
16	AN16/W16 Pkg.	80	3.1496	1/8	3/8	15/16	12	5/32	11/16	1 9/32	3 1/32
17	AN17/W17 Pkg.	85	3.3465	1/8	3/8	31/32	12	5/32	23/32	1 13/32	3 13/64
18	AN18/W18 Pkg.	90	3.5433	5/32	3/8	1 1/16	12	5/32	13/16	1 9/16	3 25/64
20	AN20/W20 Pkg.	100	3.9370	5/32	3/8	1 3/16	12	5/32	7/8	1 25/32	3 25/32
22	AN22/W22 Pkg.	110	4.3307	3/16	3/8	1 17/32	12	5/32	29/32	2 1/16	4 3/16
24	AN24/W24 Pkg.	120	4.7244	3/16	3/8	1 1/4	12	5/32	15/16	2 1/4	4 37/64
26	AN26/W26 Pkg.	130	5.1181	3/16	1/2	1 5/16	12	5/32	1	2 1/2	4 31/32
28	AN28/W28 Pkg.	140	5.5118	3/16	5/8	1 3/8	12	5/32	1 1/16	2 21/32	5 23/64
30	AN30/W30 Pkg.	150	5.9055	7/32	5/8	1 1/2	12	5/32	1 1/8	2 27/32	5 3/4
32	AN32/W32 Pkg.	160	6.2992	15/64	5/8	1 9/16	8	1/4	1 3/16	3 1/8	6 3/32
34	AN34/W34 Pkg.	170	6.6929	15/16	3/4	1 19/32	8	1/4	1 7/32	3 11/32	6 15/32
36	AN36/W36 Pkg.	180	7.0866	15/64	3/4	1 5/8	8	1/4	1 1/4	3 11/32	6 7/8
38	AN38/W38 Pkg.	190	7.4803	15/64	3/4	1 21/32	8	1/4	1 9/32	3 19/32	7 9/32
40	AN40/W40 Pkg.	200	7.8740	15/64	7/8	1 23/32	8	1/4	1 11/32	3 13/16	7 21/32
44	AN44/W44 Pkg.	220	8.6614	3/8	1 1/16	1 9/16	8	1/4	1 3/8	4 7/32	8 7/16

Bearing Size	THREAD DIAMETER					SHAFT DIAMETER						
	MAJOR A		PITCH		MINOR	S 1 Bearing Seat		S 2 Backing Shoulder		S 3 Shaft Extension		Shaft Fillet Max.
	MAX.	MIN.	MAX.	MIN.	MAX.	MIN.	MAX.	MIN.	MAX.	MIN.		
16	3.137	3.1258	3.0829	3.0770	3.0348	3.1511	3.1504	3.625	3.621	3.000	2.996	.079
17	3.340	3.3288	3.2859	3.2800	3.2378	3.3484	3.3475	3.938	3.934	3.188	3.184	.079
18	3.527	3.5158	3.4729	3.4655	3.4248	3.5452	3.5443	4.125	4.120	3.375	3.371	.079
20	3.918	3.9068	3.8639	3.8565	3.8158	3.9389	3.9380	4.500	4.495	3.813	3.809	.079
22	4.325	4.3138	4.2709	4.2626	4.2228	4.3332	4.3323	4.875	4.870	4.188	4.183	.079
24	4.716	4.7048	4.6619	4.6536	4.6138	4.7269	4.7260	5.313	5.308	4.563	4.558	.079
26	5.106	5.0948	5.0519	5.0436	5.0038	5.1209	5.1199	5.875	5.870	4.938	4.933	.098
28	5.497	5.4858	5.4429	5.4346	5.3948	5.5146	5.5136	6.250	6.244	5.313	5.308	.098
30	5.888	5.8768	5.8339	5.8256	5.7858	5.9090	5.9080	6.625	6.619	5.750	5.745	.098
32	6.284	6.2688	6.2028	6.1937	6.1306	6.3027	6.3017	7.000	6.994	6.063	6.057	.098
34	6.659	6.6438	6.5778	6.5687	6.5056	6.6964	6.6954	7.438	7.432	6.438	6.432	.118
36	7.066	7.0508	6.9848	6.9757	6.9126	7.0901	7.0891	7.813	7.807	6.875	6.869	.118
38	7.472	7.4568	7.3908	7.3817	7.3186	7.4845	7.4833	8.375	8.368	7.250	7.244	.118
40	7.847	7.8318	7.7658	7.7544	7.6936	7.8742	7.8770	8.750	8.743	7.625	7.619	.118
44	8.628	8.6128	8.5468	8.5347	8.4746	8.6662	8.6644	9.563	9.556	8.313	8.306	.118



22500 TACONITE SEALS & ENDCOVERS

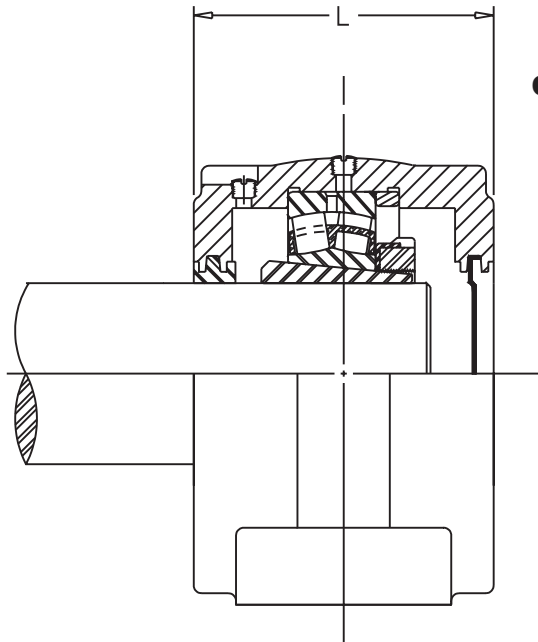

**END E
COVERS C**

22500/22200 EC END COVERS

Part Number	Dim. L
SPBT22515 X 2 7/16 EC	4.750
SPBT22515 X 2 1/2 EC	4.750
SPBT22516 X 2 11/16 EC	5.375
SPBT22516 X 2 3/4 EC	5.375
SPBT22517 X 2 15/16 EC	5.375
SPBT22517 X 3 EC	5.375
SPBT22518 X3 3/16 EC	6.250
SPBT22520 X 3 7/16 EC	6.000
SPBT22520 X3 1/2 EC	6.250
SPBF22515 X 2 7/16 EC	4.750
SPBF22515 X 2 1/2 EC	4.750
SPBF22516 X 2 11/16 EC	5.375
SPBF22516 X 2 3/4 EC	5.375
SPBF22517 X 2 15/16 EC	5.375
SPBF22517 X 3 EC	5.375
SPBF22518 X 3 3/16 EC	6.250
SPBF22520 X 3 7/16 EC	6.000
SPBF22520 X 3 1/2 EC	6.250
SPBF22522 X 3 11/16 EC	6.500
SPBF22522 X 3 15/16 EC	6.500
SPBF22522 X 4 EC	6.500
SPBF22524 X 4 3/16 EC	7.375
SPBF22526 X 4 7/16 EC	8.000
SPBF22526 X 4 1/2 EC	8.000
SPBF22528 X 4 15/16 EC	7.500
SPBF22528 X 5 EC	7.500
SPBF22530 X 5 3/16 EC	8.375
SPBF22532 X 5 7/16 EC	8.750
SPBF22532 X 5 1/2 EC	8.750
SPBF22534 X 5 15/16 EC	9.625
SPBF22534 X 6 EC	9.625
SPBF22536 X 6 7/16 EC	10.000
SPBF22536 X 6 1/2 EC	10.000
SPBF22538 X 6 15/16 EC	10.750
SPBF22538 X 7 EC	10.750
SPBF22540 X 7 3/16 EC	11.250
SPBF22544 X 7 1/2 EC	12.000
SPBF22544 X 7 15/16 EC	12.000
SPBF22544 X 8 EC	12.000
SPBF22544 X 8 EC	12.000

End Cover Part No.	For use with Housing Part No.	
	22500 Series	22200 Series
EC-15	ST515	-
	SF515	-
EC-16	ST516	-
	SF516	-
EC-17	ST517	ST216
	SF517	SF216
EC-18	ST518	ST218
	SF518	SF218
EC-20	ST520	-
	SF520	-
EC-22	SF522	-
	SF524	SF222
EC-26	SF526	SF224
	SF528	SF226
E-28	SF528	SF226
	SF530	SF228
EC-30	SF530	SF228
	SF532	-
EC-32	SF532	-
	SF534	SF232
EC-34	SF534	SF232
	SF536	SF234
EC-36	SF536	SF234
	SF538	SF236
EC-38	SF538	SF236
	SF540	SF238
EC-40	SF540	SF238
	SF544	-
EC-44	SF544	-

22500 Taconite & End Cover Combinations

TE

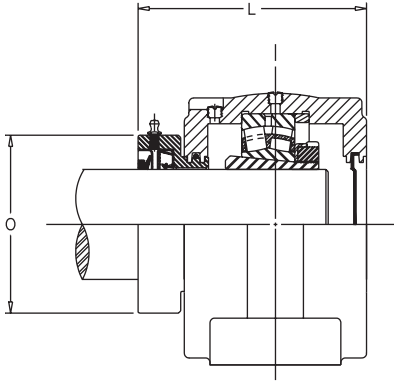

**E END COVER
C AND ONE STANDARD
LABYRINTH SEAL**

**T TACONITE
E AND END COVER**

**T TACONITE
C SEALS**

* Part Number	DIMENSIONS		* Part Number	DIMENSIONS	
	L	O		L	O
SPBT22516 X 2 7/16 TE	5 13/16	3 7/8	SPBF22522 X 3 15/16 TE	7 9/16	5 3/4
SPBT22516 X 2 11/16 TE	6 7/16	4 1/2	SPBF22524 X 4 3/16 TE	8 1/2	6
SPBT22517 X 2 15/16 TE	6 7/16	4 3/4	SPBF22526 X 4 7/16 TE	9 3/16	6 1/4
SPBT22518 X 3 3/16 TE	6 13/16	5	SPBF22528 X 4 15/16 TE	8 3/4	6 3/4
SPBT22520 X 3 7/16 TE	7 5/16	5 1/4	SPBF22532 X 5 7/16 TE	10	7 3/8
SPBF22515 X 2 7/16 TE	5 13/16	3 7/8	SPBF22534 X 5 15/16 TE	10 3/4	7 3/4
SPBF22516 X 2 11/16 TE	6 7/16	4 1/2	SPBF22536 X 6 7/16 TE	11 3/16	8 1/4
SPBF22517 X 2 15/16 TE	6 7/16	4 3/4	SPBF22538 X 6 15/16 TE	12 3/16	8 7/8
SPBF22518 X 3 3/16 TE	6 13/16	5	SPBF22544 X 7 15/16 TE	13 7/16	9 7/8
SPBF22520 X 3 7/16 TE	7 5/16	5 1/4			

Components included - When ordering part number SPBT22515 X 2 7/16 TE, for example, all of the following components are furnished:

- 1 - ST515 Housing
- 1 - SNW x 2 7/16 Adapter assembly
- 1 - EC15 End cover
- 1 - 2215CWK33C3 Bearing
- 1 - TC515207 Taconite Seal

Components are packaged individually.

* Not available from stock - contact Browning for delivery.

TC

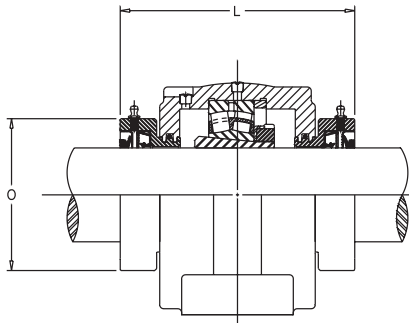

* Part Number	DIMENSIONS		* Part Number	DIMENSIONS	
	L	O		L	O
SPBT22515 X 2 7/16 TC	6 7/8	3 7/8	SPBF22522 X 3 15/16 TC	8 11/16	5 3/4
SPBT22516 X 2 11/16 TC	7 1/2	4 1/2	SPBF22524 X 4 3/16 TC	9 11/16	6
SPBT22517 X 2 15/16 TC	7 1/2	4 3/4	SPBF22526 X 4 7/16 TC	10 7/16	6 1/4
SPBT22518 X 3 3/16 TC	7 15/16	5	SPBF22528 X 4 15/16 TC	10 1/16	6 3/4
SPBT22520 X 3 7/16 TC	8 7/16	5 1/4	SPBF22532 X 5 7/16 TC	11 5/16	7 3/8
SPBF22515 X 2 7/16 TC	6 7/8	3 7/8	SPBF22534 X 5 15/16 TC	11 15/16	7 3/4
SPBF22516 X 2 11/16 TC	7 1/2	4 1/2	SPBF22536 X 6 7/16 TC	12 7/16	8 1/4
SPBF22517 X 2 15/16 TC	7 1/2	4 3/4	SPBF22538 X 6 15/16 TC	13 11/16	8 7/8
SPBF22518 X 3 3/16 TC	7 15/16	5	SPBF22544 X 7 15/16 TC	14 15/16	9 7/8
SPBF22520 X 3 7/16 TC	8 7/16	5 1/4			

Components included - When ordering part number SPBT22515 X 2 7/16 TE, for example, all of the following components are furnished:

- 1 - ST515 Housing
- 1 - SNW x 2 7/16 Adapter assembly
- 1 - 2215CWK33C3 Bearing
- 1 - TC515207 Taconite Seal

Components are packaged individually.

* Not available from stock - contact Browning for delivery.

Browning®

22200 Series

T2000-2 BOLT

TAKE-UP FRAME T
22200 2
SPHERICAL 0
BEARING 0
BEARING SERIES 0
SHAFT DIA CODE A
TWO BOLT MOUNTINGS 2

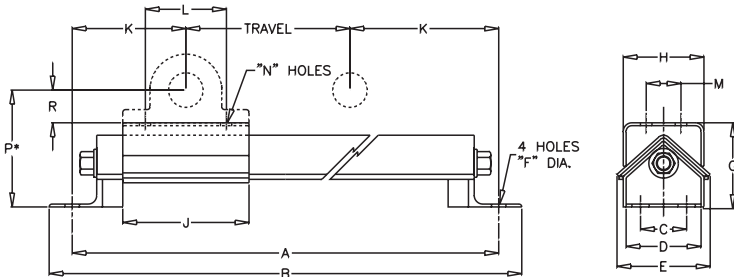

SHAFT DIA. IN	FRAME PART NO.	TRAVEL	Dimensions In Inches														UNIT WT.
			A	B	C	D	E	F	G	H	J	K	L	M	N		
			No.	Dia.													
1 7/16	12T2000A2	12	29	31	2 1/2	4 1/2	6 3/16	11/16	5 1/4	4	11	8 1/2	6 5/8	0	2	9/16	55
	18T2000A2	18	35	37	2 1/2	4 1/2	6 3/16	11/16	5 1/4	4	11	8 1/2	6 5/8	0	2	9/16	60
	24T2000A2	24	41	43	2 1/2	4 1/2	6 3/16	11/16	5 1/4	4	11	8 1/2	6 5/8	0	2	9/16	65
	30T2000A2	30	47	49	2 1/2	4 1/2	6 3/16	11/16	5 1/4	4	11	8 1/2	6 5/8	0	2	9/16	69
	36T2000A2	36	53	55	2 1/2	4 1/2	6 3/16	11/16	5 1/4	4	11	8 1/2	6 5/8	0	2	9/16	75
1 11/16	12T2000B2	12	29	31	2 1/2	4 1/2	6 3/16	11/16	5 1/4	4	11	8 1/2	6 3/4	0	2	9/16	55
	18T2000B2	18	35	37	2 1/2	4 1/2	6 3/16	11/16	5 1/4	4	11	8 1/2	6 3/4	0	2	9/16	60
	24T2000B2	24	41	43	2 1/2	4 1/2	6 3/16	11/16	5 1/4	4	11	8 1/2	6 3/4	0	2	9/16	65
	30T2000B2	30	47	49	2 1/2	4 1/2	6 3/16	11/16	5 1/4	4	11	8 1/2	6 3/4	0	2	9/16	69
	36T2000B2	36	53	55	2 1/2	4 1/2	6 3/16	11/16	5 1/4	4	11	8 1/2	6 3/4	0	2	9/16	75
1 15/16	12T2000C2	12	29	31	2 1/2	4 1/2	6 3/16	11/16	5 1/4	4	11	8 1/2	7 5/8	0	2	11/16	55
	18T2000C2	18	35	37	2 1/2	4 1/2	6 3/16	11/16	5 1/4	4	11	8 1/2	7 5/8	0	2	11/16	60
	24T2000C2	24	41	43	2 1/2	4 1/2	6 3/16	11/16	5 1/4	4	11	8 1/2	7 5/8	0	2	11/16	65
	30T2000C2	30	47	49	2 1/2	4 1/2	6 3/16	11/16	5 1/4	4	11	8 1/2	7 5/8	0	2	11/16	69
	36T2000C2	36	53	55	2 1/2	4 1/2	6 3/16	11/16	5 1/4	4	11	8 1/2	7 5/8	0	2	11/16	75
2 3/16	18T2000D2	18	38 3/4	41 1/4	3	5 1/8	7 1/16	11/16	6 1/4	4 3/4	13 1/4	10 3/8	8 7/8	0	2	3/4	86
	24T2000D2	24	44 3/4	47 1/4	3	5 1/8	7 1/16	11/16	6 1/4	4 3/4	13 1/4	10 3/8	8 7/8	0	2	3/4	88
	30T2000D2	30	50 3/4	53 1/4	3	5 1/8	7 1/16	11/16	6 1/4	4 3/4	13 1/4	10 3/8	8 7/8	0	2	3/4	90
	36T2000D2	36	56 3/4	59 1/4	3	5 1/8	7 1/16	11/16	6 1/4	4 3/4	13 1/4	10 3/8	8 7/8	0	2	3/4	96
2 7/16	18T2000E2	18	38 3/4	41 1/4	3	5 1/8	7 1/16	11/16	6 1/4	4 3/4	13 1/4	10 3/8	8 7/8	0	2	3/4	86
	24T2000E2	24	44 3/4	47 1/4	3	5 1/8	7 1/16	11/16	6 1/4	4 3/4	13 1/4	10 3/8	8 7/8	0	2	3/4	88
	30T2000E2	30	50 3/4	53 1/4	3	5 1/8	7 1/16	11/16	6 1/4	4 3/4	13 1/4	10 3/8	8 7/8	0	2	3/4	90
	36T2000E2	36	56 3/4	59 1/4	3	5 1/8	7 1/16	11/16	6 1/4	4 3/4	13 1/4	10 3/8	8 7/8	0	2	3/4	96
2 11/16	18T2000F2	18	41 1/2	44 1/4	3	6	8 5/8	13/16	7	5	14 1/4	11 3/4	10 7/16	0	2	7/8	138
	24T2000F2	24	47 1/2	50 1/4	3	6	8 5/8	13/16	7	5	14 1/4	11 3/4	10 7/16	0	2	7/8	148
	30T2000F2	30	53 1/2	56 1/4	3	6	8 5/8	13/16	7	5	14 1/4	11 3/4	10 7/16	0	2	7/8	155
	36T2000F2	36	59 1/2	62 1/4	3	6	8 5/8	13/16	7	5	14 1/4	11 3/4	10 7/16	0	2	7/8	168
	48T2000F2	48	71 1/2	74 1/4	3	6	8 5/8	13/16	7	5	14 1/4	11 3/4	10 7/16	0	2	7/8	185
2 15/16	18T2000G2	18	41 1/2	44 1/4	3	6	8 5/8	13/16	7	5	14 1/4	11 3/4	10 7/16	0	2	7/8	138
	24T2000G2	24	47 1/2	50 1/4	3	6	8 5/8	13/16	7	5	14 1/4	11 3/4	10 7/16	0	2	7/8	148
	30T2000G2	30	53 1/2	56 1/4	3	6	8 5/8	13/16	7	5	14 1/4	11 3/4	10 7/16	0	2	7/8	155
	36T2000G2	36	59 1/2	62 1/4	3	6	8 5/8	13/16	7	5	14 1/4	11 3/4	10 7/16	0	2	7/8	168
	48T2000G2	48	71 1/2	74 1/4	3	6	8 5/8	13/16	7	5	14 1/4	11 3/4	10 7/16	0	2	7/8	185
3 3/16	18T2000H2	18	43 1/4	46	3	6	8 5/8	13/16	7	6	16	12 5/8	11	0	2	7/8	150
	24T2000H2	24	49 1/4	52	3	6	8 5/8	13/16	7	6	16	12 5/8	11	0	2	7/8	160
	30T2000H2	30	55 1/4	58	3	6	8 5/8	13/16	7	6	16	12 5/8	11	0	2	7/8	170
	36T2000H2	36	61 1/4	64	3	6	8 5/8	13/16	7	6	16	12 5/8	11	0	2	7/8	180
	48T2000H2	48	73 1/4	76	3	6	8 5/8	13/16	7	6	16	12 5/8	11	0	2	7/8	200
3 7/16	18T2000J2	18	43 1/4	46	3	6	8 5/8	13/16	7	6	16	12 5/8	12 3/8	0	2	1	150
	24T2000J2	24	49 1/4	52	3	6	8 5/8	13/16	7	6	16	12 5/8	12 3/8	0	2	1	160
	30T2000J2	30	55 1/4	58	3	6	8 5/8	13/16	7	6	16	12 5/8	12 3/8	0	2	1	170
	36T2000J2	36	61 1/4	64	3	6	8 5/8	13/16	7	6	16	12 5/8	12 3/8	0	2	1	180
	48T2000J2	48	73 1/4	76	3	6	8 5/8	13/16	7	6	16	12 5/8	12 3/8	0	2	1	200

**P" = "G" + "R" = shaft height of manufacturer's pillow block.
 Other pillow block mounting hole patterns are available on request.
 Type of manufacturer's pillow block and number of mounting holes should be stated on purchase order.
 For sizes of take-up frames not listed, contact the Browning Engineering Department.

T2000-4 BOLT

- T TAKE-UP FRAME**
- 2 22200**
- 0 SPHERICAL**
- 0 BEARING**
- 0 SERIES**
- A SHAFT PIN CODE**
- 4 FOUR BOLT MOUNTING**

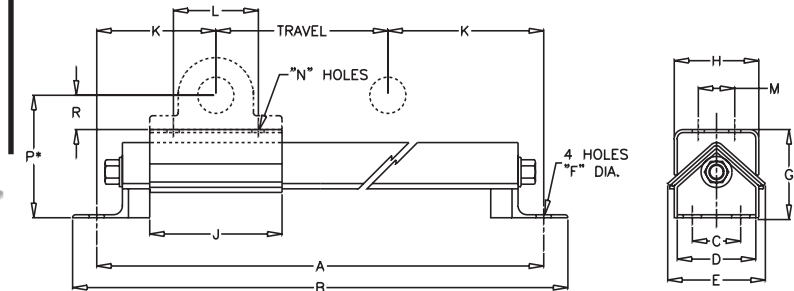

SHAFT DIA. IN	FRAME PART NO.	TRAVEL	Dimensions In Inches													UNIT WT.	
			A	B	C	D	E	F	G	H	J	K	L	M	N		
			No.	Dia.													
2 3/16	18T2000D4	18	38 3/4	41 1/4	3	5 1/8	7 1/16	11/16	6 1/4	4 3/4	13 1/4	10 3/8	8 7/8	2	4	5/8	86
	24T2000D4	24	44 3/4	47 1/4	3	5 1/8	7 1/16	11/16	6 1/4	4 3/4	13 1/4	10 3/8	8 7/8	2	4	5/8	88
	30T2000D4	30	50 3/4	53 1/4	3	5 1/8	7 1/16	11/16	6 1/4	4 3/4	13 1/4	10 3/8	8 7/8	2	4	5/8	90
	36T2000D4	36	56 3/4	59 1/4	3	5 1/8	7 1/16	11/16	6 1/4	4 3/4	13 1/4	10 3/8	8 7/8	2	4	5/8	96
2 7/16	18T2000E4	18	38 3/4	41 1/4	3	5 1/8	7 1/16	11/16	6 1/4	4 3/4	13 1/4	10 3/8	8 7/8	1 7/8	4	5/8	86
	24T2000E4	24	44 3/4	47 1/4	3	5 1/8	7 1/16	11/16	6 1/4	4 3/4	13 1/4	10 3/8	8 7/8	1 7/8	4	5/8	88
	30T2000E4	30	50 3/4	53 1/4	3	5 1/8	7 1/16	11/16	6 1/4	4 3/4	13 1/4	10 3/8	8 7/8	1 7/8	4	5/8	90
	36T2000E4	36	56 3/4	59 1/4	3	5 1/8	7 1/16	11/16	6 1/4	4 3/4	13 1/4	10 3/8	8 7/8	1 7/8	4	5/8	96
2 11/16	18T2000F4	18	41 1/2	44 1/4	3	6	8 5/8	13/16	7	5	14 1/4	11 3/4	10 7/16	2 1/8	4	3/4	138
	24T2000F4	24	47 1/2	50 1/4	3	6	8 5/8	13/16	7	5	14 1/4	11 3/4	10 7/16	2 1/8	4	3/4	148
	30T2000F4	30	53 1/2	56 1/4	3	6	8 5/8	13/16	7	5	14 1/4	11 3/4	10 7/16	2 1/8	4	3/4	155
	36T2000F4	36	59 1/2	62 1/4	3	6	8 5/8	13/16	7	5	14 1/4	11 3/4	10 7/16	2 1/8	4	3/4	168
	48T2000F4	48	71 1/2	74 1/4	3	6	8 5/8	13/16	7	5	14 1/4	11 3/4	10 7/16	2 1/8	4	3/4	185
2 15/16	18T2000G4	18	41 1/2	44 1/4	3	6	8 5/8	13/16	7	5	14 1/4	11 3/4	10 7/16	2 1/8	4	3/4	138
	24T2000G4	24	47 1/2	50 1/4	3	6	8 5/8	13/16	7	5	14 1/4	11 3/4	10 7/16	2 1/8	4	3/4	148
	30T2000G4	30	53 1/2	56 1/4	3	6	8 5/8	13/16	7	5	14 1/4	11 3/4	10 7/16	2 1/8	4	3/4	155
	36T2000G4	36	59 1/2	62 1/4	3	6	8 5/8	13/16	7	5	14 1/4	11 3/4	10 7/16	2 1/8	4	3/4	168
3 3/16	18T2000H4	18	43 1/4	46	3	6	8 5/8	13/16	7	6	16	12 5/8	11	2 1/8	4	3/4	150
	24T2000H4	24	49 1/4	52	3	6	8 5/8	13/16	7	6	16	12 5/8	11	2 1/8	4	3/4	160
	30T2000H4	30	55 1/4	58	3	6	8 5/8	13/16	7	6	16	12 5/8	11	2 1/8	4	3/4	170
	36T2000H4	36	61 1/4	64	3	6	8 5/8	13/16	7	6	16	12 5/8	11	2 1/8	4	3/4	180
3 7/16	18T2000J4	18	43 1/4	46	3	6	8 5/8	13/16	7	6	16	12 5/8	12 3/8	2 3/8	4	7/8	150
	24T2000J4	24	49 1/4	52	3	6	8 5/8	13/16	7	6	16	12 5/8	12 3/8	2 3/8	4	7/8	160
	30T2000J4	30	55 1/4	58	3	6	8 5/8	13/16	7	6	16	12 5/8	12 3/8	2 3/8	4	7/8	170
	36T2000J4	36	61 1/4	64	3	6	8 5/8	13/16	7	6	16	12 5/8	12 3/8	2 3/8	4	7/8	180
3 15/16	18T2000K4	18	47 1/4	50	3	6	8 5/8	13/16	7	7 1/4	20	14 5/8	13 9/16	2 3/4	4	7/8	177
	24T2000K4	24	53 1/4	56	3	6	8 5/8	13/16	7	7 1/4	20	14 5/8	13 9/16	2 3/4	4	7/8	187
	30T2000K4	30	59 1/4	62	3	6	8 5/8	13/16	7	7 1/4	20	14 5/8	13 9/16	2 3/4	4	7/8	197
	36T2000K4	36	65 1/4	68	3	6	8 5/8	13/16	7	7 1/4	20	14 5/8	13 9/16	2 3/4	4	7/8	207
4 7/16	18T2000M4	18	53	55 1/2	4	7	10 1/4	15/16	7 3/4	8 1/2	23 1/2	17 1/2	15 5/16	3 1/4	4	1	280
	24T2000M4	24	59	61 1/2	4	7	10 1/4	15/16	7 3/4	8 1/2	23 1/2	17 1/2	15 5/16	3 1/4	4	1	296
	30T2000M4	30	65	67 1/2	4	7	10 1/4	15/16	7 3/4	8 1/2	23 1/2	17 1/2	15 5/16	3 1/4	4	1	306
	36T2000M4	36	71	73 1/2	4	7	10 1/4	15/16	7 3/4	8 1/2	23 1/2	17 1/2	15 5/16	3 1/4	4	1	318
4 15/16	18T2000N4	18	53	55 1/2	4	7	10 1/4	15/16	7 3/4	8 1/2	23 1/2	17 1/2	16 9/16	3 3/8	4	1 1/8	280
	24T2000N4	24	59	61 1/2	4	7	10 1/4	15/16	7 3/4	8 1/2	23 1/2	17 1/2	16 9/16	3 3/8	4	1 1/8	296
	30T2000N4	30	65	67 1/2	4	7	10 1/4	15/16	7 3/4	8 1/2	23 1/2	17 1/2	16 9/16	3 3/8	4	1 1/8	306
	36T2000N4	36	71	73 1/2	4	7	10 1/4	15/16	7 3/4	8 1/2	23 1/2	17 1/2	16 9/16	3 3/8	4	1 1/8	318
48T2000N4	48	83	85 1/2	4	7	10 1/4	15/16	7 3/4	8 1/2	23 1/2	17 1/2	16 9/16	3 3/8	4	1 1/8	345	

P = "G" + "R" = shaft height of manufacturer's pillow block.
 Other pillow block mounting hole patterns are available on request.
 Type of manufacturer's pillow block and number of mounting holes should be stated on purchase order.
 For sizes of take-up frames not listed, contact the Browning Engineering Department.

Browning®

Spherical Roller Bearings

Spherical Roller Bearings 22200 and 22500 Series

This chart displays the Browning 22200 and 22500 Series Spherical Roller Bearing's load capacity for a given L10 life, speed and shaft size. Values in the table represent loads at ideal conditions. For combined load determination, see **THE BEARING SELECTION SECTION**, page 269. Areas designated by “-” exceed maximum speed value.

Match Bore Size

Size	Rating	L10 Hours	REVOLUTIONS PER MINUTE												
			50	100	150	250	500	750	1000	1500	1750	2000	2500	3000	3500
22215	47,700	5000	13966	13966	13966	13966	10609	9394	8618	7631	7286	7000	6546	6198	—
		10000	13966	13966	12367	10609	8618	7631	7000	6198	5918	5685	5317	5034	—
		30000	12367	10045	8894	7631	6198	5488	5034	4458	4256	4089	3824	3621	—
		50000	10609	8618	7631	6546	5317	4708	4319	3824	3652	3508	3281	3106	—
		100000	8618	7000	6198	5317	4319	3824	3508	3106	2966	2849	2665	2523	—
22216	53,100	5000	15550	15550	15550	14540	11811	10458	9593	8494	8111	7792	7288	6900	—
		10000	15550	15550	13767	11811	9593	8494	7792	6900	6588	6329	5919	5604	—
		30000	13767	11182	9901	8494	6900	6109	5604	4962	4738	4552	4257	4031	—
		50000	11811	9593	8494	7288	5919	5241	4808	4257	4065	3905	3652	3458	—
		100000	9593	7792	6900	5919	4808	4257	3905	3458	3302	3172	2967	2809	—
22217	55,100	5000	16134	16134	16134	15088	12255	10852	9954	8814	8416	8086	7562	7159	—
		10000	16134	16134	14285	12255	9954	8814	8086	7159	6836	6567	6142	5815	—
		30000	14285	11603	10274	8814	7159	6339	5815	5149	4917	4723	4418	4183	—
		50000	12255	9954	8814	7562	6142	5439	4989	4418	4218	4052	3790	3588	—
		100000	9954	8086	7159	6142	4989	4418	4052	3588	3426	3292	3078	2915	—
22218	73,100	5000	21405	21405	21405	20017	16259	14397	13206	11694	11165	10727	10032	—	
		10000	21405	21405	18952	16259	13206	11694	10727	9498	9069	8713	8149	—	
		30000	18952	15394	13630	11694	9498	8410	7715	6831	6523	6267	5861	—	
		50000	16259	13206	11694	10032	8149	7215	6619	5861	5596	5376	5028	—	
		100000	13206	10727	9498	8149	6619	5861	5376	4760	4545	4367	4084	—	
22220	95,500	5000	27965	27965	27965	26151	21241	18808	17253	15277	14587	14014	—		
		10000	27965	27965	24759	21241	17253	15277	14014	12409	11848	11383	—		
		30000	24759	20111	17807	15277	12409	10988	10079	8925	8521	8187	—		
		50000	21241	17253	15277	13107	10646	9427	8647	7657	7311	7024	—		
		100000	17253	14014	12409	10646	8647	7657	7024	6219	5938	5705	—		
22222	105,000	5000	30745	30745	30745	28752	23354	20679	18969	16797	16038	15408	—		
		10000	30745	30745	27222	23354	18969	16797	15408	13643	13027	12515	—		
		30000	27222	22111	19579	16797	13643	12081	11082	9813	9369	9001	—		
		50000	23354	18969	16797	14410	11705	10364	9507	8418	8038	7722	—		
		100000	18969	15408	13643	11705	9507	8418	7722	6838	6529	6272	—		
22224	121,000	5000	35430	35430	35430	33134	26913	23831	21860	19356	18482	—			
		10000	35430	35430	31370	26913	21860	19356	17756	15722	15012	—			
		30000	31370	25480	22562	19356	15722	13922	12770	11308	10797	—			
		50000	26913	21860	19356	16606	13488	11944	10956	9701	9263	—			
		100000	21860	17756	15722	13488	10956	9701	8899	7880	7524	—			
22226	142,000	5000	41580	41580	41580	38884	31584	27966	25654	22716	21689	—			
		10000	41580	41580	36814	31584	25654	22716	20837	18451	17617	—			
		30000	36814	29903	26478	22716	18451	16338	14987	13270	12671	—			
		50000	31584	25654	22716	19488	15829	14016	12857	11385	10870	—			
		100000	25654	20837	18451	15829	12857	11385	10443	9247	8829	—			
22228	160,000	5000	46850	46850	46850	43813	35587	31511	28906	25595	—				
		10000	46850	46850	41481	35587	28906	25595	23479	20790	—				
		30000	41481	33693	29834	25595	20790	18409	16887	14952	—				
		50000	35587	28906	25595	21959	17836	15793	14487	12828	—				
		100000	28906	23479	20790	17836	14487	12828	11767	10420	—				
22230	191,000	5000	55930	55930	55930	52302	42482	37617	34506	30554	—				
		10000	55930	55930	49518	42482	34506	30554	28028	24818	—				
		30000	49518	40221	35614	30554	24818	21975	20158	17850	—				
		50000	42482	34506	30554	26213	21292	18853	17294	15313	—				
		100000	34506	28028	24818	21292	17294	15313	14047	12438	—				
22232	225,000	5000	65885	65885	65885	61612	50045	44313	40649	35993	—				
		10000	65885	65885	58333	50045	40649	35993	33017	29236	—				
		30000	58333	47381	41954	35993	29236	25887	23747	21027	—				
		50000	50045	40649	35993	30879	25082	22209	20373	18039	—				
		100000	40649	33017	29236	25082	20373	18039	16548	14653	—				
22234	252,000	5000	73790	73790	73790	69006	56050	49630	45527	—	—				
		10000	73790	73790	65333	56050	45527	40312	36979	—	—				
		30000	65333	53067	46989	40312	32744	28994	26596	—	—				
		50000	56050	45527	40312	34585	28092	24874	22817	—	—				
		100000	45527	36979	32744	28092	22817	20204	18534	—	—				
22236	265,000	5000	77600	77600	77600	69006	56050	49630	45527	—	—				
		10000	77600	77600	65333	56050	45527	40312	36979	—	—				
		30000	65333	53067	46989	40312	32744	28994	26596	—	—				
		50000	56050	45527	40312	34585	28092	24874	22817	—	—				
		100000	45527	36979	32744	28092	22817	20204	18534	—	—				
22238	250,000	5000	73198	73198	73198	68458	55605	49237	45165	—	—				
		10000	73198	73198	64814	55605	45165	39993	36686	—	—				
		30000	64814	52645	46616	39993	32484	28764	26385	—	—				
		50000	55605	25654	22716	19488	15829	14016	12857	—	—				
		100000	45165	36686	32484	27869	22636	20044	18386	—	—				
22240	328,000	5000	96045	96045	96045	89817	72954	64598	59257	—	—				
		10000	96045	96045	85036	72954	59257	52470	48132	—	—				
		30000	85036	69071	61160	52470	42619	37738	34617	—	—				
		50000	72954	59257	52470	45015	36564	32376	29699	—	—				
		100000	59257	48132	42619	36564	29699	26297	24123	—	—				
22244	396,000	5000	115960	115960	115960	108437	88079	77991	—	—	—				
		10000	115960	115945	102666	88079	71542	63348	—	—	—				
		30000	102666	83390	73839	63348	51455	45561	—	—	—				
		50000	88079	71542	63348	54347	44144	39088	—	—	—				
		100000	71542	58110	51455	44144	35856	31749	—	—	—				