

**NTN**<sup>®</sup>

# **Bower<sup>®</sup> Type E Bearing Units**



CAT. No. A-2300

# Bower Type E is your solution for longer uptime in demanding applications.

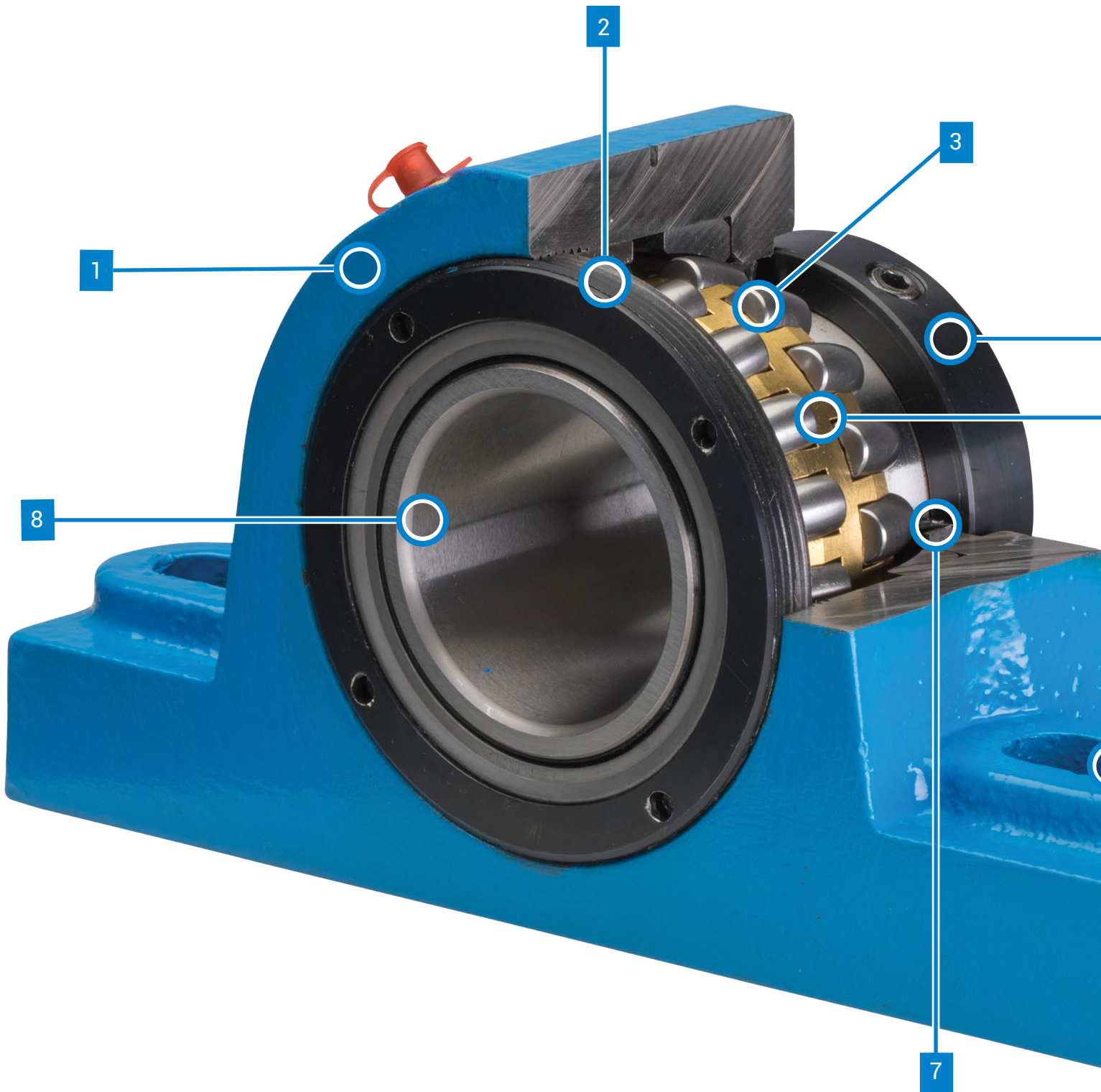

# The Better Option

Less downtime.  
More profitability.

The Bower Type E with spherical roller bearing insert has what it takes to keep your equipment up and running. The bearing unit arrives fully assembled with grease and C3 bearing clearance. The spherical roller bearing insert allows for +/- 2° of misalignment to handle applications that may induce misalignment due to shaft deflection or uneven mounting surfaces. Bower Type E housings are made of cast iron with elongated bolt holes and are dimensionally interchangeable with competitive Type E bearing units.

## Product Features & Benefits

- 1 One-piece, sturdy cast iron housing to withstand demanding applications
- 2 Threaded housing nut keeps the bearing clearance set and provides great seal support
- 3 Self-aligning, double-row spherical roller bearing allows for easy alignment and can handle +/- 2° of misalignment
- 4 Set screw locking collar secures the inner ring to the shaft
- 5 Machined brass retainer with offset pockets results in cage stiffness for high vibratory applications
- 6 Elongated mounting slots for versatile mounting configurations
- 7 Double-lip seal molded onto a metal guard provides superior sealing performance in extreme environments
- 8 Extended inner ring allows for greater contact surface to the shaft which provides better performance and stability

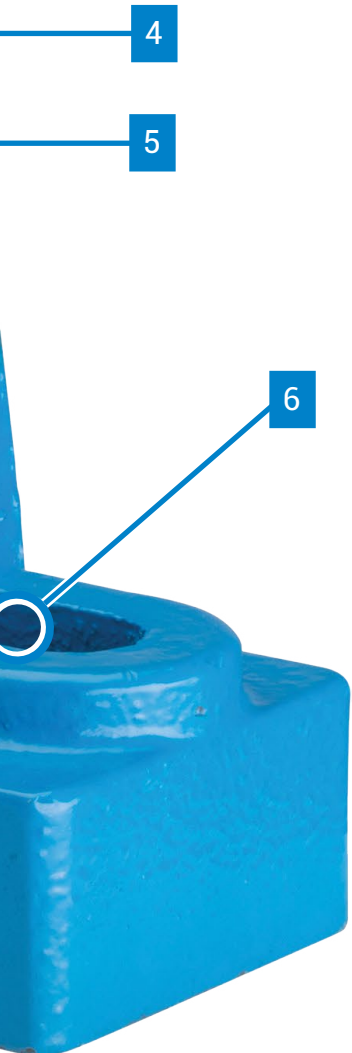

# Bower Type E Nomenclature System

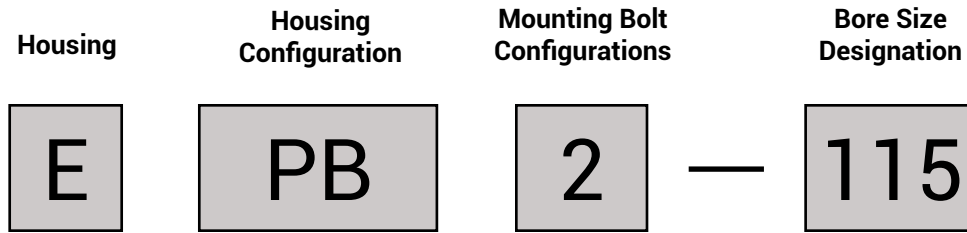

**1. HOUSING**

E: Type E dimensions

**2. HOUSING CONFIGURATION**

PB: Pillow block, cast iron

**3. MOUNTING BOLTS CONFIGURATION**

- 2: Two-bolt
- 4: Four-bolt

**4. BORE SIZE DESIGNATION**

- 115: 1 15/16"
- 203: 2 3/16"
- 307: 3 7/16"
- 415: 4 15/16"



**Find the part you need, when you need it, every time.**

NTN Bearing Finder is much more than just a basic online catalog- it's your digital support partner. This industry-leading search tool is home to all the information and content you need to find the right bearing for your application.

- Customizable Search Tool
- Interactive CAD Illustrations
- Comprehensive Part Interchanges
- Accurate & Up-To-Date Data

[bearingfinder.ntnamericas.com](http://bearingfinder.ntnamericas.com)

# Bower Type E Industries & Applications

## Aggregate/Cement/Mining



- Material Handling Equipment
- Fans & Blowers
- Augers
- Bucket Elevators
- Pulleys
- Belt Press

**MI** MINING

## Sawmills



- Drying Kilns
- Processing Equipment
- Material Handling Equipment

**PF** PAPER & FORESTRY

## Food Processing



- Grain/Meat/Fruit & Vegetable Handling Equipment
- Mixers
- Washers
- Ovens

**FB** FOOD & BEVERAGE

## Power Generation



- Material Handling Equipment
- Fans & Blower

**PG** POWER GENERATION

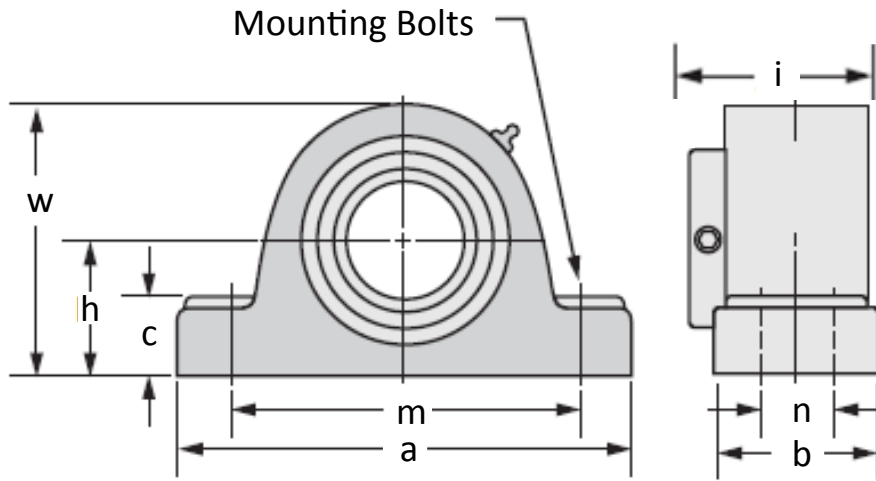

"n" is distance between bolt centers for 4-bolt base

### 2 Bolt Pillow Blocks

Shaft Diameter	Bearing Unit Part Number	h	a	b	c	m	
						min	max
1 7/16"	EPB2-107	1 7/8" 47.6	7 3/8" 187.3	2 1/4" 57.2	1 1/8" 28.6	4 3/4" 120.7	6" 152.4
1 15/16"	EPB2-115	2 1/4" 57.2	8 7/8" 225.4	2 1/2" 63.5	1 3/8" 34.9	6" 152.4	7 5/16" 185.7
2 3/16"	EPB2-203	2 1/2" 63.5	9 5/8" 244.5	2 5/8" 66.7	1 9/16" 39.7	6 5/8" 168.3	8 1/16" 204.8
2 7/16"	EPB2-207	2 3/4" 69.9	10 7/16" 265.1	2 5/8" 66.7	1 9/16" 39.7	7 1/8" 181.0	8 7/8" 225.4
2 15/16"	EPB2-215	3 1/8" 79.4	11 13/16" 300.0	3 3/16" 81.0	1 7/8" 47.6	8 1/16" 204.8	10" 254.0
3 7/16"	EPB2-307	3 3/4" 95.3	13 3/4" 349.3	3 9/16" 90.5	2 1/4" 57.2	9 5/8" 244.5	11 1/2" 292.1

### 4 Bolt Pillow Blocks

Shaft Diameter	Bearing Unit Part Number	h	a	b	c	m	
						min	max
2 7/16"	EPB4-207	2 3/4" 69.9	10 7/16" 265.1	3 7/16" 87.3	1 9/16" 39.7	7 1/8" 181.0	8 7/8" 225.4
2 15/16"	EPB4-215	3 1/8" 79.4	11 13/16" 300.0	4" 101.6	1 7/8" 47.6	7 15/16" 201.6	9 15/16" 252.4
3 7/16"	EPB4-307	3 3/4" 95.3	13 3/4" 349.3	4 3/4" 120.7	2 1/4" 57.2	9 5/16" 236.5	11 7/16" 290.5
3 15/16"	EPB4-315	4 1/4" 108.0	15 1/4" 387.4	4 1/2" 114.3	2 5/8" 66.7	11 7/8" 301.6	12 15/16" 328.6
4 7/16"	EPB4-407	4 3/4" 120.7	16 9/16" 420.7	4 13/16" 122.2	2 13/16" 71.4	12 5/8" 320.7	13 3/4" 349.3
4 15/16"	EPB4-415	5 1/2" 139.7	18 7/16" 468.3	5 1/4" 133.4	3 1/16" 77.8	15" 381.0	16 1/8" 409.6

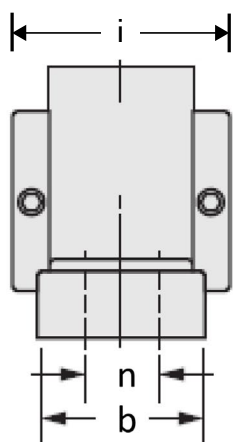

4 7/16" and 4 15/16"



	n	w	i	Mounting Bolts		Load Rating		Limiting Speed Grease	Approx. Weight (lbs)
				Size	Number	Static	Dynamic		
-		3 7/8" 98.4	2 7/8" 73.0	1/2" 12.7	2	25,900	18,000	3,300	9
-		4 5/8" 117.5	3 3/16" 81.0	5/8" 15.9	2	38,200	29,400	2,500	13
-		5" 127.0	3 3/8" 85.7	5/8" 15.9	2	48,100	34,000	2,200	19
-		5 1/2" 139.7	3 1/2" 88.9	5/8" 15.9	2	54,200	38,000	2,000	20
-		6 3/8" 161.9	4 1/16" 103.2	3/4" 19.1	2	80,500	54,900	1,700	29
-		7 1/2" 190.5	4 7/16" 112.7	7/8" 22.2	2	93,500	63,600	1,400	46

	n	w	i	Mounting Bolts		Load Rating		Limiting Speed Grease	Approx. Weight (lbs)
				Size	Number	Static	Dynamic		
	1 7/8" 47.6	5 1/2" 139.7	3 1/2" 88.9	5/8" 15.9	4	54,200	38,000	2,000	21
	2 1/8" 54.0	6 3/8" 161.9	4 1/16" 103.2	5/8" 15.9	4	80,500	54,900	1,700	33
	2 3/8" 60.3	7 1/2" 190.5	4 7/16" 112.7	3/4" 19.1	4	93,500	63,600	1,400	52
	2 1/4" 57.2	8 7/16" 214.3	5 1/16" 128.6	3/4" 19.1	4	133,800	95,500	1,300	69
	2 1/2" 63.5	9 3/8" 238.1	6 3/4" 171.5	3/4" 19.1	4	163,200	109,300	1,100	90
	2 7/8" 73.0	10 15/16" 277.8	7 1/4" 184.2	7/8" 22.2	4	230,200	148,600	1,000	133

# Bower Type E Interchange Guide

Shaft Size	# of Bolts	Bower	Dodge	Link-Belt	REX	Rexnord RPT
		Spherical	Spherical	Spherical	Spherical	Spherical
1 7/16"	2	EPB2-107	EP2B-S2-107R	EPB22423H	ZEP2107	EP2B107T
1 15/16"	2	EPB2-115	EP2B-S2-115R	EPB22431H	ZEP2115	EP2B115T
2 3/16"	2	EPB2-203	EP2B-S2-203R	EPB22435H	ZEP2203	EP2B203T
2 7/16"	2	EPB2-207	EP2B-S2-207R	EPB22439H	ZEP2207	EP2B207T
2 7/16"	4	EPB4-207	EP4B-S2-207R	EPB22439FH	ZEP2207F	
2 15/16"	2	EPB2-215	EP2B-S2-215R	EPB22447H	ZEP2215	EP2B215T
2 15/16"	4	EPB4-215	EP4B-S2-215R	EPB22447FH	ZEP2215F	
3 7/16"	2	EPB2-307	EP2B-S2-307R	EPB22455H	ZEP2307	EP2B307T
3 7/16"	4	EPB4-307	EP4B-S2-307R	EPB22455FH	ZEP2307F	
3 15/16"	4	EPB4-315	EP4B-S2-315R	EPB22463FH	ZEP2315F	
4 7/16"	4	EPB4-407	EP4B-S2-407R	EPB22571YFH		
4 15/16"	4	EPB4-415	EP4B-S2-415R	EPB22579YFH		

Shaft Size	# of Bolts	Bower	Dodge	Timken
		Spherical	Taper	Taper
1 7/16"	2	EPB2-107	P2B-E-107R	E-P2B-TRB-1 7/16
1 15/16"	2	EPB2-115	P2B-E-115R	E-P2B-TRB-1 15/16
2 3/16"	2	EPB2-203	P2B-E-203R	E-P2B-TRB-2 3/16
2 7/16"	2	EPB2-207	P2B-E-207R	E-P2B-TRB-2 7/16
2 7/16"	4	EPB4-207	P4B-E-207R	E-P4B-TRB-2 7/16
2 15/16"	2	EPB2-215	P2B-E-215R	E-P2B-TRB-2 15/16
2 15/16"	4	EPB4-215	P4B-E-215R	E-P4B-TRB-2 15/17
3 7/16"	2	EPB2-307	P2B-E-307R	E-P2B-TRB-3 7/16
3 7/16"	4	EPB4-307	P4B-E-307R	E-P4B-TRB-3 7/17
3 15/16"	4	EPB4-315	P4B-E-315R	E-P4B-TRB-3 15/16
4 7/16"	4	EPB4-407	P4B-E-407R	E-P4B-TRB-4 7/16
4 15/16"	4	EPB4-415	P4B-E-415R	E-P4B-TRB-4 15/16



	SKF	Timken QM	SealMaster	Moline	Hub City	PTI
	Spherical	Spherical	Spherical	Spherical	Spherical	Spherical
	P2BE107-SRB-SRH	QAP08A107SM		29222107	KPBE1-7/16DN	SREPB2-107R3NE
	P2BE115-SRB-SRH	QAP10A115SM	USRBE5000-115	29222115	KPBE1-15/16DN	SREPB2-115R3NE
	P2BE203-SRB-SRH	QAP11A203SM	USRBE5000-203	29222203	KPBE2-3/16DN	SREPB2-203R3NE
	P2BE207-SRB-SRH	QAP13A207SM	USRBE5000-207	29222207	KPBE2-7/16DN	SREPB2-207R3NE
	P4BE207-SRB-SRH	QAPR13Z207SM				SREPB4-207R3NE
	P4BE207-SRB-SRH	QAP15A215SM	USRBE5000-215	29222215	KPBE2-15/16DN	SREPB2-215R3NE
	P4BE215-SRB-SRH	QAPR15A215SM				SREPB4-215R3NE
	P2BE307-SRB-SRH	QAP18A307SM	USRBE5000-307	29222307	KPBE3-7/16DN	SREPB2-307R3NE
	P4BE307-SRB-SRH	QAPR18A307SM			KPBEF3-7/16DN	SREPB4-307R3NE
	P4BE315-SRB-SRH		USRBE5000-315		KPBEF3-15/16DN	SREPB4-315R3NE
	P4BE407-SRB-SRH				KPBEF4-7/16DN	SREPB4-407R3NE
	P4BE415-SRB-SRH				KPBEF4-15/16DN	SREPB4-415R3NE

	Browning	Moline	Jones	Royersford
	Taper	Taper	Taper	Taper
	PBE920x1 7/16	19321107	JE2107	20-02-0107
	PBE920X1 15/16	19321115	JE2115	20-02-0115
	PBE920x2 3/16	19321203	JE2203	20-02-0203
	PBE920x2 7/16	19321207	JE2207	20-02-0207
	PBE920Fx2 7/16	19341207	JE2207F	20-04-0207
	PBE920x2 15/16	19321215	JE2215	20-02-0215
	PBE920Fx2 15/16	19341215	JE2215F	20-04-0215
	PBE920x3 7/16	19321307	JE2307	20-02-0307
	PBE920Fx3 7/16	19341307	JE2307F	20-04-0307
	PBE920Fx3 15/16	19341315	JE2315F	20-04-0315
		19341407	JE5407F	20-04-0407
		19341415	JE5415F	20-04-0415

# Bower Type E Installation & Maintenance Instructions

1. Clean the shaft and the bearing bore. The shaft should be straight, free of nicks & burrs, and correctly sized.

Shaft tolerances should be as follows:

Allowable Shaft Tolerances	
Shaft Diameter	Recommended Tolerances*
1 7/16"	+0.0000" -0.0005"
2 3/16" thru 4"	+0.0000" -0.0010"
4 7/16" thru 4 15/16"	+0.0000" -0.0015"

\* Commercial grad shafts may be used for very slow speed applications. Consult NTN Engineering.

2. Lubricate bearing bore and shaft with grease or oil to ease installation of bearing onto the shaft. Position bearing on the shaft, applying pressure to the face of the inner ring with a hardwood block or soft metal drift. **DO NOT** strike or apply pressure on housing or seals.
3. Align the bearing housing to its mounting base. Use shims to align the bearing so that the inner ring has equal clearance around the housing bore. When shimming is required, use full shims across the entire housing base, not just the bolt holes.
4. Position the housing and loosely bolt the housing to the mounting base. SAE Grade 5 bolts are recommended.
5. Lock the bearing to the shaft by tightening the collar set screws to the recommended torque listed below. Alternate torquing the set screws to prevent unequal loading on the bearing.

Recommended Set Screw Torque	
Shaft Size	Torque (in-lb)
1 7/16"	325
2 3/16"	460
2 7/16" thru 3 7/16"	680
3 15/16" thru 4 15/16"	1,350

6. Check bearing rotation. If there is irregular resistance, rotation or vibrations, check bearing alignment and straightness of shafting and mounting. Correct as necessary.

# Bower Type E Lubrication Information

Bearings are prelubricated with No. 2 lithium base grease. No additional lubrication is necessary before startup.

## Relubrication Instructions

Lubricate bearings with a high quality No. 2 lithium base grease that is compatible with original grease and suitable for precision bearing services. Extra protection may be required in environments with excessive moisture, dust or corrosive vapor. In these conditions it is recommended that the bearing contain as much grease as the bearing speed allows.

High Speed & High Temperature Applications – excess grease may cause overheating of the bearing. In these applications it is recommended that small amounts of grease be added frequently to provide better lubrication instead of adding large amounts of grease less frequently.

When equipment will not be in operation for extended periods of time, grease should be added to provide corrosion protection, particularly for equipment exposed to severe weather.

Mixing of any 2 greases should be checked with the lubrication manufacturer for compatibility. Mixing of different greases should never be done.

## Suggested Grease Intervals

Suggested Greasing Intervals		
Conditions	0°F to 120°F (-20°C to 50°C)	120°F to 200°F (50° to 90°C)
Clean	2 to 6 months	1 to 2 months
Moderate	2 weeks to 2 months	1 to 4 weeks
Dirty	1 to 4 weeks	1 to 7 days
Extremely Dirty	Daily	Every Shift

# Bower Type E Engineering

Dynamic self alignment  $\pm 2^\circ$

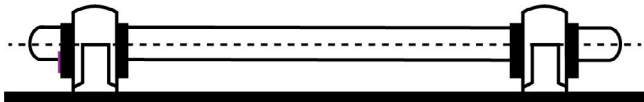
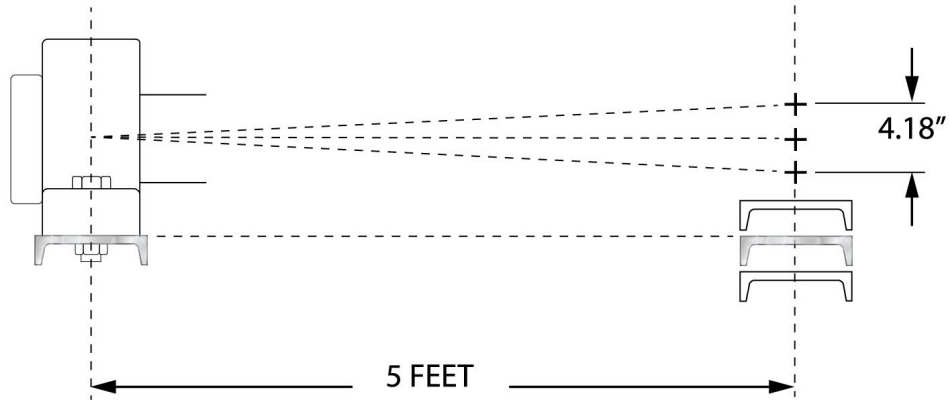

BEFORE

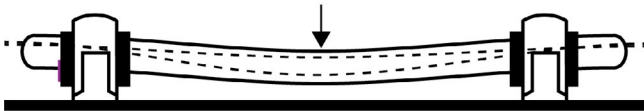
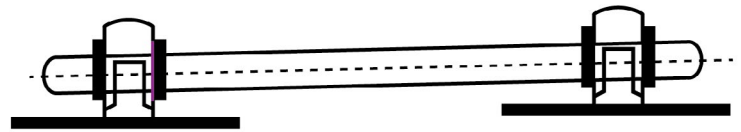

AFTER

Dynamic – can accommodate variations in alignment during operation

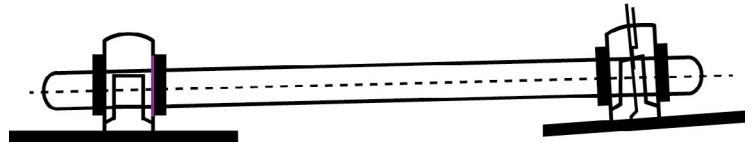

Static – alignment adjusted prior to operation

Demanding applications require rugged seal protection to keep your equipment up and running. The Bower Type E is protected by a double lip contact seal that is designed to keep contamination out and allows for grease purge during regular maintenance. The nitrile double lip seals are protected from falling debris and heavy bulk material by a metal jacket to ensure longer bearing life.

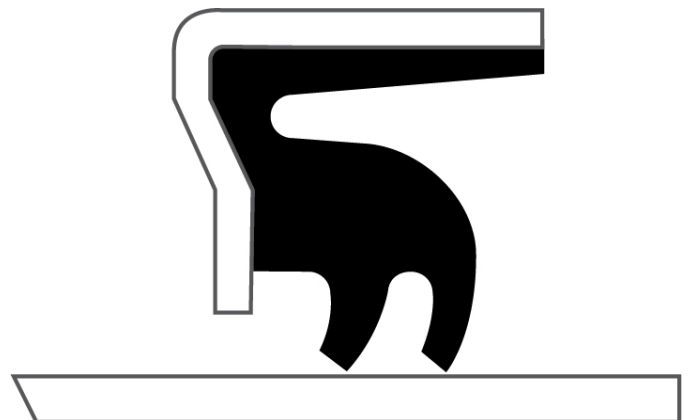

# Bower Type E Accessories

Over 55% of premature bearing failures are lubrication related. The most common causes are missed lubrication intervals, applying the wrong type or amount of lubricant, applying lubricant at incorrect intervals based on recommendations, excessive pressure resulting in seal failure, and/or contamination ingress. All of these problems are preventable. NTN automatic lubricators provide a constant and controlled supply of quality grease, 24 hours a day, 7 days a week.

## READY: Gas-powered



*All-in-one gas-powered lubricator; no activator required.*

## SMART: Electro-chemical



*Advanced gas-powered unit; not affected by temperature changes.*

## DRIVE: Electro-mechanical



*Motorized unit; provides precise lubrication amount; 360 degree lights allow for instant status updates.*



Since 1918, NTN has been a trusted OE manufacturer of high-performing bearing products that increase companies' productivity and efficiency.

- NTN has been the world's broad-line bearing manufacturer for nearly 100 years.
- NTN has the largest bearing manufacturing footprint in the United States.
- NTN is the largest supplier of American-made products to the construction and mining industries.
- NTN is a major supplier to over two-thirds of the world's "Fortune 500" manufacturing companies.
- More cars worldwide ride on NTN bearings and drivetrains than any other manufacturer's product.



◀ NTN was the first bearing manufacturer to be awarded the prestigious Deming Prize for recognition of its quality products and systems.

# Beyond Bearings

Training. Installation Support.  
Trouble-shooting. And more.

When you choose NTN, your team is equipped with all the necessary tools and resources to get the job done right. From installation to problem-solving, we'll be there with the hands-on support you need to take on your toughest challenges. This includes extra services such as:



## Technical Training Unit

On-site, mobile training unit offering specialized, hands-on instruction from NTN engineers



## Product Training School

Three days of in-depth instruction from NTN engineers at NTN headquarters  
([go.ntnamericas.com/trainingschool](http://go.ntnamericas.com/trainingschool))



## eKnowledge

WEB-BASED TRAINING PROGRAM

Six online product training modules covering different bearing types and nomenclature  
([www.ntnamericas.com/eknowledge](http://www.ntnamericas.com/eknowledge))



## NTN Bearing Finder

Customizable search tool featuring exhaustive data sets, comprehensive part interchanges and interactive CAD drawings  
([bearingfinder.ntnamericas.com](http://bearingfinder.ntnamericas.com))



Ready to get rolling? Contact us today for full details at  
1-800-323-2358 or [eng@ntnamerica.com](mailto:eng@ntnamerica.com).

# NTN<sup>®</sup>

NTN BEARING CORPORATION OF AMERICA • 1600 E. Bishop Court • Mount Prospect, IL 60056-7604, U.S.A.

Tel: 847-298-7500 • Fax: 847-294-1205 • [www.ntnamericas.com](http://www.ntnamericas.com)