



The *Motion-Transfer* Specialists



Contents

	Page No.		Page No.
Engineering Data - Product Information	3-5	<u>SPHERICAL BEARINGS</u>	
Commercial/Industrial Units		COM, HCOM Standard Series.....	45
<u>ROD ENDS</u>		COM-KH, HCOM-KH Wear Resistant.....	46
SPM, SPB Male Molded Race Series.....	6	COM-E Stainless Series.....	47
SPW, SPG Female Molded Race Series.....	7	LCOM Large Size.....	48
CM, CB Male 2 pc. Economy.....	8	AIB, SIB, MIB, MIB-T	49
CW, CG Female 2 pc. Economy.....	9	FRACTURED RACE Spherical Plain Bearings - Inch.....	50
VCM, VCB Male Economy PTFE Lined.....	10	FRACTURED RACE Spherical Plain Bearings - Metric.....	51
VCW, VCG Female Economy PTFE Lined.....	11	FRACTURED RACE Spherical Plain Bearings - Inch PTFE	52
MM, MB Male 3 pc. Precision.....	12	FRACTURED RACE Spherical Plain Bearings - Metric PTFE	53
MW, MG Female 3 pc. Precision.....	13	SUGGESTED HOUSING BORES - Inch, Metric.....	54
MM-T, MB-T Male 3 pc. PTFE Lined.....	14	SUGGESTED HOUSING BORES - COM, HCOM, AIB, MIB, SIB....	55
MW-T, MG-T Female 3 pc. PTFE Lined.....	15	SUGGESTED HOUSING BORES - LCOM, COM-M.....	56
KM, KB Male 3 pc. Wear Resistant.....	16	<u>SPECIAL UNITS</u>	
KW, KG Female 3 pc. Wear Resistant.....	17	HB Ball Bearing Rod Ends.....	57
KM, KB, AM, AB Male Large Bore.....	18	High Performance Units	
KW, KG, AW, AG Female Large Bore.....	19	<u>ROD ENDS</u>	
LARGE BORE Male PTFE Lined.....	20	XM, XB Male 3 pc. Extra Strength.....	58
LARGE BORE Female PTFE Lined.....	21	XAM, XAB Male 3 pc. High Strength Alloy.....	59
CAM Male 2 pc. High Strength.....	22	RAM, RXAM Male 3 pc. High Strength Nickel Plated.....	60
VCAM Male 2 pc. High Strength PTFE Lined.....	23	HXAM-T, HXAB-T Male High Misalign/Strength PTFE Lined.....	61
AM, AB Male 3 pc. High Strength.....	24	PRM-T, PRXM-T Male 3 pc. High Performance PTFE Lined.....	62
AW, AG Female 3 pc. High Strength.....	25	ALM, ALB, XALM, XALB Male Aluminum 3pc Series.....	64
CM-ET, CB-ET Male Corrosion Resistant.....	26	<u>SPHERICAL BEARINGS</u>	
CW-ET, CG-ET Female Corrosion Resistant.....	27	HAB-T High Misalignment PTFE Lined.....	61
SM, SB Male 3 pc. Corrosion Resistant.....	28	PNB-T, PNB-TG High Performance Narrow PTFE Lined.....	63
SW, SG Female 3 pc. Corrosion Resistant.....	29	PWB-T, PWB-TG High Performance Wide PTFE Lined.....	63
SM-E, SB-E Male 3 pc. Stainless Steel.....	30	Military Specification Units	
SW-E, SG-E Female 3 pc. Stainless Steel.....	31	<u>ROD ENDS</u>	
CM-S, CB-S Male 2 pc. Economy w/Stud.....	32	ASM-T, ASB-T Male High Strength PTFE Lined.....	66
CW-S, CG-S Female 2 pc Economy w/Stud.....	33	ASW-T, ASG-T Female High Strength PTFE Lined.....	67
CL, CL-S Rod End Linkages.....	34	<u>SPHERICAL BEARINGS</u>	
<u>METRIC ROD ENDS AND SPHERICAL BEARINGS</u>		ANC-T, ANC-TG Narrow PTFE Lined.....	68
CM-M, CB-M Male 2 pc. Metric Economy.....	35	AWC-T, AWC-TG Wide PTFE Lined.....	69
CW-M, CG-M Female 2 pc. Metric Economy.....	35	<u>ROD ENDS</u>	
MM-M, MB-M Male 3 pc. Metric Precision.....	36	GMM, GMB Male General Aviation.....	70
MW-M, MG-M Female 3 pc. Metric Precision.....	37	GMW, GMG Female General Aviation.....	71
MM-MT, MB-MT Male 3 pc. Metric PTFE Lined.....	38	<u>ADDITIONAL DATA</u>	
MW-MT, MG-MT Female 3 pc. Metric PTFE Lined.....	39	Spherical Bearing Installation.....	72, 73
KM-M, KB-M Male 3 pc. Metric Wear Resistant.....	40	Engineering Information/Tables.....	74, 75
KW-M, KG-M Female 3 pc. Metric Wear Resistant.....	41		
AM-M, AB-M Male 3 pc. Metric High Strength.....	42		
AW-M, AG-M Female 3 pc. Metric High Strength.....	43		
COM-M Metric Spherical Bearings.....	44		



AURORA BEARING COMPANY...

Manufacturer and worldwide supplier of the highest quality rod ends and spherical bearings - *anywhere!*

General Information

In 1971 a new company entered the rod end and spherical bearing marketplace. This new firm, Aurora Bearing Company, soon became a major force in the rod end industry.

Known primarily for a high quality product and a strong commitment to customer service, the firm dramatically increased its market coverage and now serves nearly every industry and aerospace market. These markets include among others: textile and packaging machinery, machine tools, business machines, recreation and exercise equipment, agricultural and off highway vehicles, commercial transportation and high performance racing vehicles as well as military equipment and commercial air and space craft.

Over the years, Aurora Bearing has retained its original business philosophy of furnishing a high quality product at competitive prices. In addition, the company's initial goals of providing prompt delivery and furnishing service with a personal touch have been rigidly maintained.

Aurora Bearing offers a complete line of standard rod end and spherical bearings. We also design and manufacture special bearings to meet a variety of applications that require custom engineered units or special materials.

Now marketing products worldwide, Aurora Bearing fields a very competent sales force that is available to assist and provide you with a practical and sound solution to rod end and spherical bearing application problems and challenges.

Product Information- Engineering Data

ROD ENDS

Aurora Bearing Company rod ends are manufactured utilizing two construction styles. They are of the two or three-piece type. Both are made with the solid, or one-piece, race construction method and feature the advantages of metal-to-metal contact between bearing components. (PTFE to metal interface may also be incorporated when specified).

The standard two-piece style consists of a body and precision ground oil impregnated sintered steel ball. This type of construction allows the rod end body to carry a greater radial static load and the oil-impregnated ball is self-lubricating under normal operating conditions. This unit also offers greater misalignment capabilities. A variety of materials and plating options for the component parts in this series are available. Any cold-formable steel in stainless and alloy steel categories can be specified for the body, and all hardenable alloys such as 52100 and 440C stainless

steel may be employed as options for the ball component.

The three-piece style consists of a body, ball and race. This type of unit, offering fully swaged bearing construction, features the advantages of maximum spherical conformity between the ball and race. It also offers flexibility in that many different types of materials can be interchanged in each component part, providing combinations that can be tailored to meet just about any application requirement.

Consult our engineering department for materials to fit your special application. Materials used in the standard catalog items are outlined on the appropriate detail page.

SPHERICAL BEARINGS

These bearings incorporate the single piece race type construction, also providing excellent ball-to-race conformity. They can be re-lubricated through an annular groove in the outer race with two interconnecting holes positioned at 180 degrees. Various metals may also be substituted in these types of units to meet special requirements. Recommended housing bores are given on pages 47-49.

PTFE LINED ROD ENDS AND SPHERICAL BEARINGS

PTFE (bonded coated PTFE liner) lined races are available in all three-piece bearing units and all spherical bearings. The steel race has a self-lubricating liner; a PTFE impregnated woven fabric, chemically bonded to the inner diameter of the race. Aurora Bearing offers two major liner style options: both are maintenance free and offer improved frictional characteristics.

AT1400 is supplied as the standard liner in all except the military specification bearings. It is designed primarily to satisfy the demands of the commercial/industrial market as well as most high performance applications. This liner can be used in temperatures ranging from -65° to +250° F.

AT3200 is an ultra-high performance liner fully qualified to SAE-AS81820(formerly MIL-B-81820), developed for military and aircraft/aerospace applications. This liner offers higher load carrying capacity as well as greatly increased dynamic wear characteristics and can be used in temperatures ranging from -65° to +325° F. This liner is now standard on all military specification bearings manufactured by Aurora Bearing, as well as certain high performance commercial bearings as used in the automotive racing industry. It can also be specified on other lined products manufactured by Aurora Bearing where demanding applications require its superior performance characteristics. Aurora Bearing also has available a variety of alternate liner configurations to suit special requirements.

ULTIMATE RADIAL STATIC LOAD CAPACITY ROD ENDS

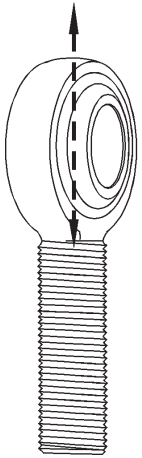

The ultimate radial static load capacity is based upon the minimum mechanical properties of the design configuration in the stressed area. The ultimate radial static load capacity called out in the rod end specification charts is defined as a single cycle, unidirectional applied load to cause ultimate failure. Operating loads should be based on the static load ratings, incorporating appropriate safety factors to suit the application. When a rod end is to be applied in full rotation, up to a maximum of 100 RPM, the operating loads should not exceed 10% of the ultimate radial static load.

Load ratings listed in the standard detail pages are applicable to rod ends supplied without grease fittings. Load ratings for units employing fittings may be affected due to lighter cross section in the stressed area. For information on the rod end radial static load ratings with fittings and other specific load rating information, consult the Aurora Bearing engineering department.

AXIAL STATIC LOAD CAPACITY ROD ENDS

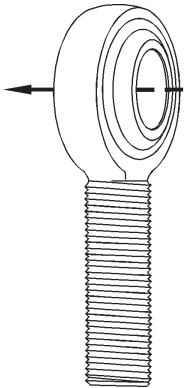

Axial static load capacity is the force that is applied through the bore of the ball. For Aurora two-piece rod ends, maximum axial static load capacity is recommended to be 15 percent of the ultimate radial static load capacity. For three-piece rod ends, maximum axial static load capacity is generally recommended as 10 percent of ultimate radial static load capacity. It should be noted, however, that on three-piece units factors such as race material, body material and dimensions may affect axial static load capacity. For further information, consult the Aurora Bearing engineering department.

RADIAL STATIC LOAD CAPACITY SPHERICAL BEARINGS

Radial static loads are maximum static based on the maximum permanent set in the bearing race of 0.2% of the ball diameter. If greater permanent set can be allowed or if alternate race materials are used consult our engineering department for change factors. Operating loads are based on the radial static load rating and appropriate safety factors should be utilized to suit the application.

Max axial load is recommended at 20 percent of the radial static load. Extreme care should be used on selecting a sufficiently strong housing to accept this type of bearing.

BEARING MISALIGNMENT

A rod end or spherical bearing's ability to misalign is measured by the degree of angle the ball can accommodate without interference.

The angle of misalignment in a rod end is limited by the ball width and head diameter as shown in figure 1. This arrangement is called a clevis mount, and is the type represented in the standard rod end detail pages. If added misalignment is necessary, this can be accomplished by utilizing spacers between the clevis mounting and ball face, or by using special rod ends designed to meet specific requirements.

Misalignment angle in a spherical bearing is limited by the ball and race width with respect to the ball diameter, illustrated in figure 3. This is the mounting type represented in the standard detail pages for spherical bearings.

Mounting arrangements for spherical bearings such as shown in figures 2 through 4 are also used with rod ends. The misalignment angle is then calculated by selecting the proper formula.

Angle of Misalignment

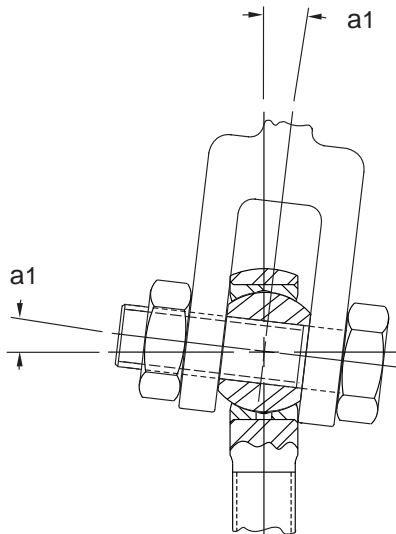

FIGURE 1

$$a1 = \sin^{-1} \frac{W}{D} - \sin^{-1} \frac{H}{D}$$

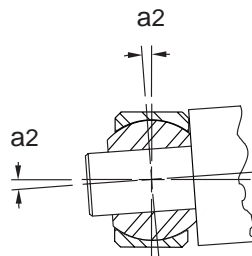

FIGURE 2

$$a2 = \sin^{-1} \frac{W}{A} - \sin^{-1} \frac{H}{A}$$

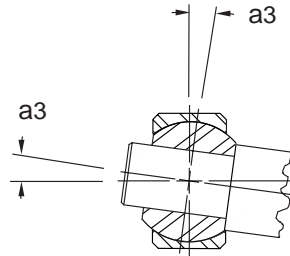

FIGURE 3

$$a3 = \sin^{-1} \frac{W}{R} - \sin^{-1} \frac{H}{R}$$

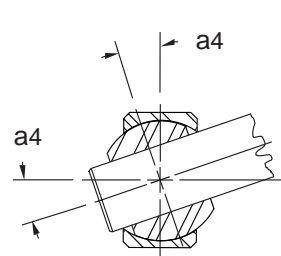

FIGURE 4

$$a4 = \cos^{-1} \frac{B}{R} - \sin^{-1} \frac{H}{R}$$

Reference Letters

- B - Ball Bore
- M - Outer Race Chamfer
- D - Head Diameter of Outer Race Diameter
- R - Ball Diameter
- H - Housing Width
- $A = \sqrt{(D-2M)^2 + H^2}$
- W - Ball Width



3-Piece and 2-Piece Bearing Design

3-Piece A & M Series Unit

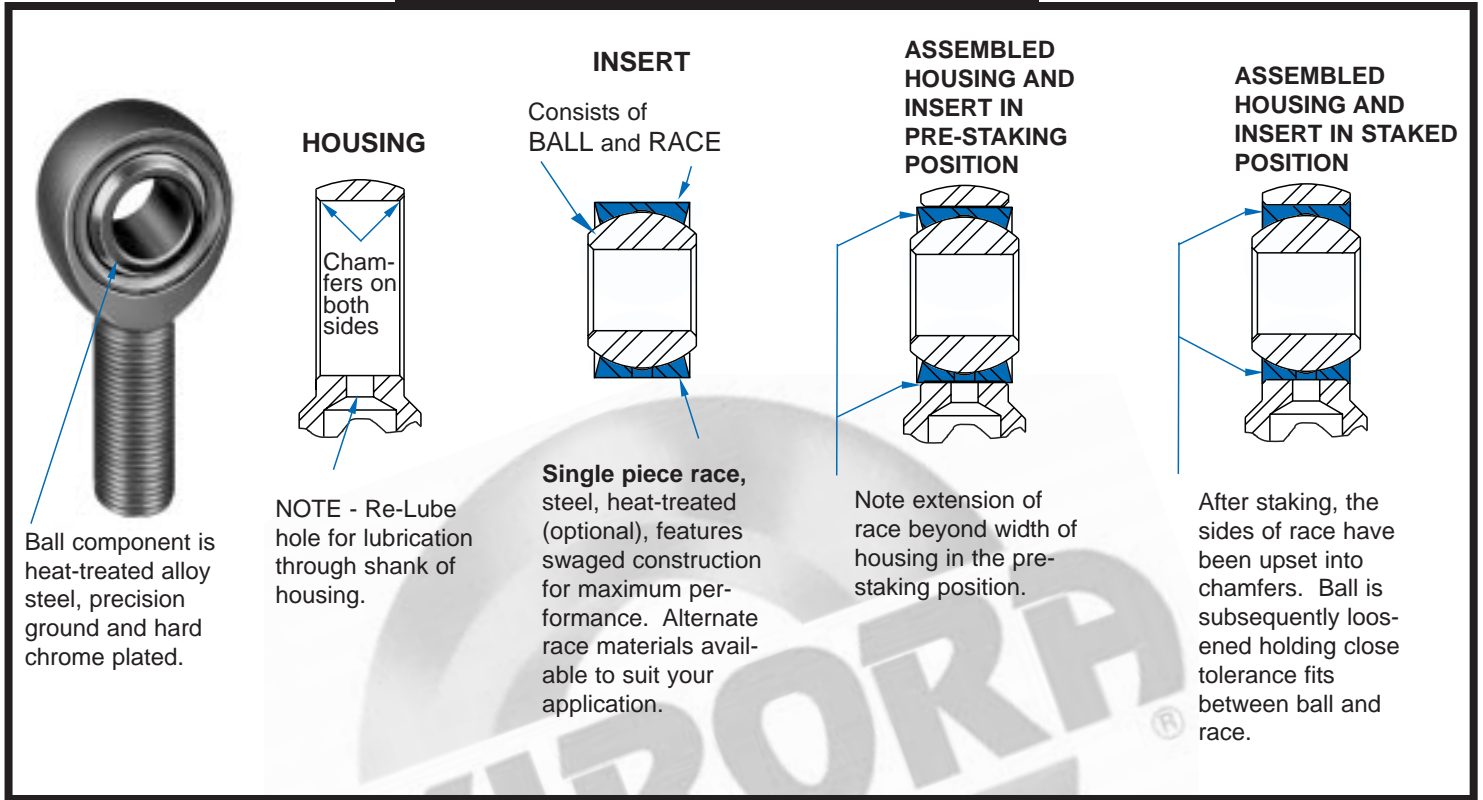

2-Piece C Series Unit

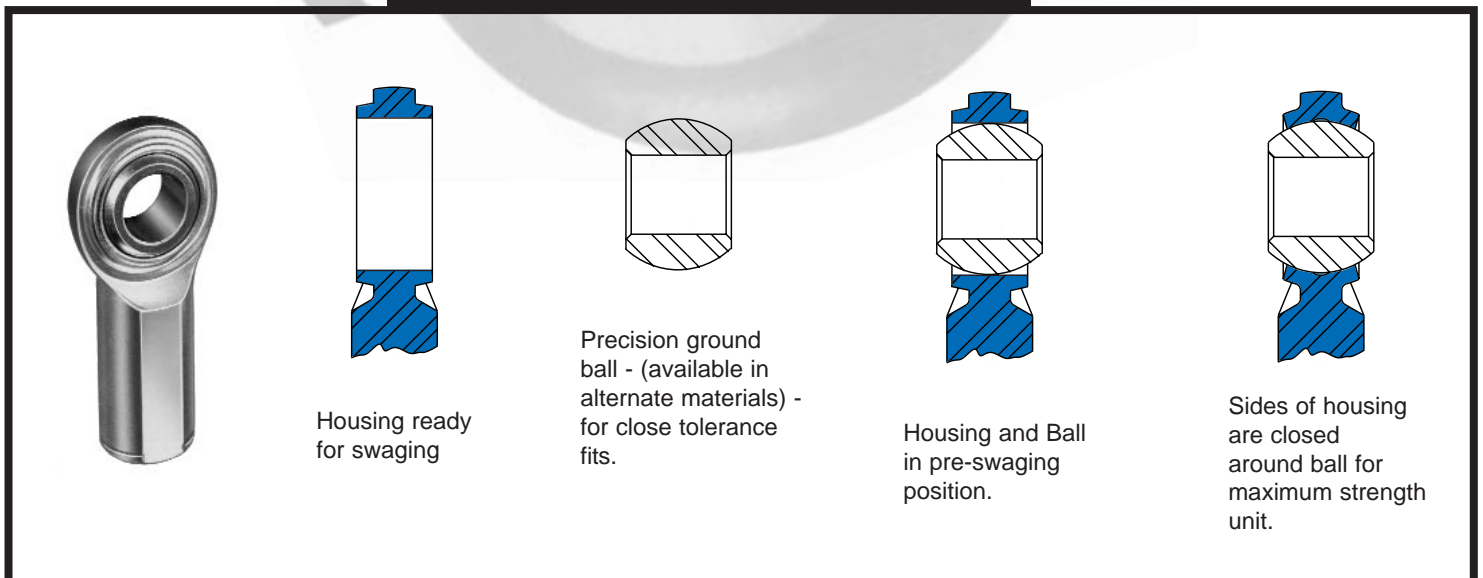



SPM & SPB Molded Race Series Male Rod Ends

Low Friction & High Wear Resistance

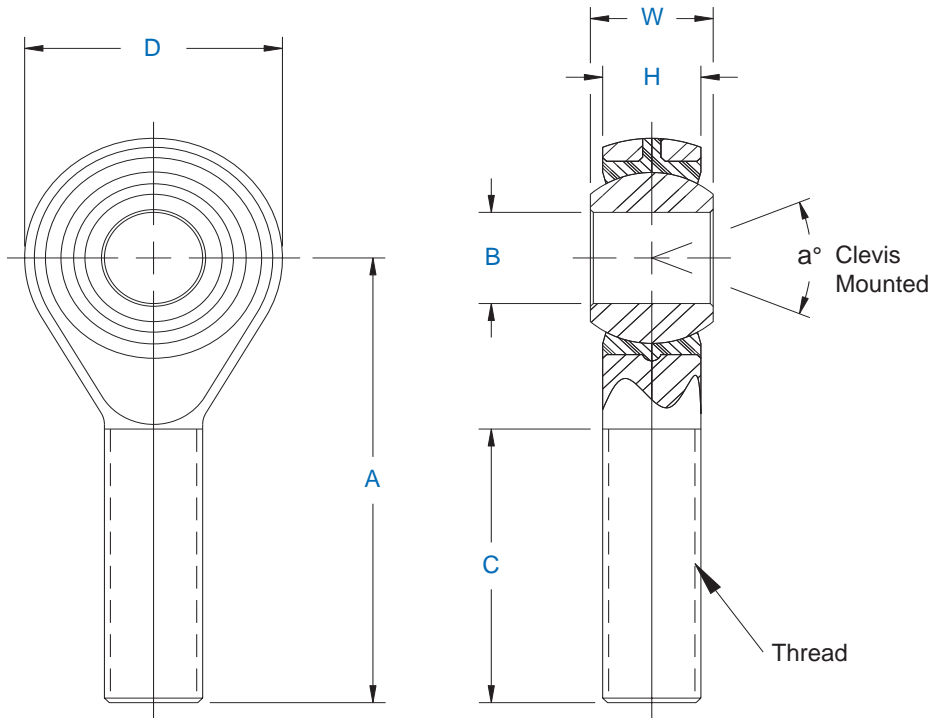

Specifications
Body - Carbon steel, protective coated for corrosion resistance.
Ball - Alloy steel, heat treated, hard chrome plated.
Race - Molded, self-lubricating, reinforced Nylon.

Rod End No.		DIMENSIONS IN INCHES								a° Misalign. Angle	Ultimate Radial Static Load Capacity Lbs.	Approx. Brg. Wt. Lbs.
Right Hand	Left Hand	B + .0020 - .0000	W \pm .005	H Ref.	A \pm .060	D \pm .015	Ball Dia. Ref.	C \pm .062	Thread UNF-2A			
SPM-3	SPB-3	.1900	.312	.250	1.250	.625	.437	.750	10-32	13	1,210	.023
SPM-4	SPB-4	.2500	.375	.281	1.562	.750	.500	1.000	1/4-28	16	2,470	.040
SPM-5	SPB-5	.3125	.437	.344	1.875	.875	.625	1.250	5/16-24	14	2,740	.071
SPM-6	SPB-6	.3750	.500	.406	1.938	1.000	.719	1.250	3/8-24	12	4,210	.107
SPM-7	SPB-7	.4375	.562	.437	2.125	1.125	.812	1.375	7/16-20	14	5,350	.148
SPM-8	SPB-8	.5000	.625	.500	2.438	1.312	.937	1.500	1/2-20	12	6,430	.232
SPM-10	SPB-10	.6250	.750	.562	2.625	1.500	1.125	1.625	5/8-18	16	8,300	.364
SPM-12	SPB-12	.7500	.875	.687	2.875	1.750	1.312	1.750	3/4-16	14	10,900	.568

This series features a molded race compound designed to provide low friction, low moisture absorbing properties and high wear resistance.

This series is also available in a studed configuration. Specify by adding suffix "S." Ex: SPM-8S



SPW & SPG Molded Race Series Female Rod Ends

Low Friction & High Wear Resistance

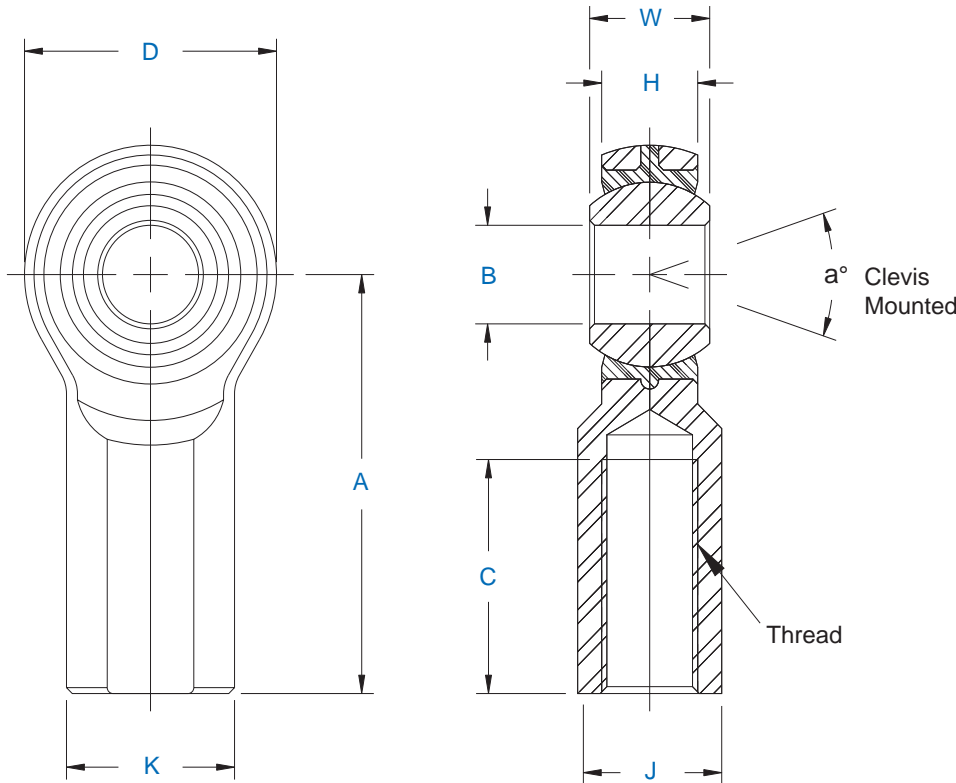

Specifications
Body - Carbon steel, protective coated for corrosion resistance.
Ball - Alloy steel, heat treated, hard chrome plated.
Race - Molded, self-lubricating, reinforced Nylon.

Rod End No.		DIMENSIONS IN INCHES										a° Misaln. Angle	Ultimate Radial Static Load Capacity Lbs.	Approx. Brg. Wt. Lbs.
Right Hand	Left Hand	B + .0020 - .0000	W ± .005	H Ref.	A ± .060	D ± .015	K ± .015	J ± .015	Ball Dia. Ref.	C ± .062	Thread UNF-2B			
SPW-3	SPG-3	.1900	.312	.250	1.062	.625	.406	.312	.437	.562	10-32	13	1,210	.036
SPW-4	SPG-4	.2500	.375	.281	1.312	.750	.469	.375	.500	.750	1/4-28	16	2,470	.059
SPW-5	SPG-5	.3125	.437	.344	1.375	.875	.500	.437	.625	.750	5/16-24	14	2,740	.077
SPW-6	SPG-6	.3750	.500	.406	1.625	1.000	.687	.562	.719	.937	3/8-24	12	4,100	.146
SPW-7	SPG-7	.4375	.562	.437	1.812	1.125	.750	.625	.812	1.062	7/16-20	14	5,350	.192
SPW-8	SPG-8	.5000	.625	.500	2.125	1.312	.875	.750	.937	1.187	1/2-20	12	6,430	.313
SPW-10	SPG-10	.6250	.750	.562	2.500	1.500	1.000	.875	1.125	1.500	5/8-18	16	8,300	.464
SPW-12	SPG-12	.7500	.875	.687	2.875	1.750	1.125	1.000	1.312	1.750	3/4-16	14	10,900	.672

This series features a molded race compound designed to provide low friction, low moisture absorbing properties and high wear resistance.

This series is also available in a studed configuration. Specify by adding suffix "S." Ex: SPW-8S



CM & CB Series Male Rod Ends

General Purpose - Economy

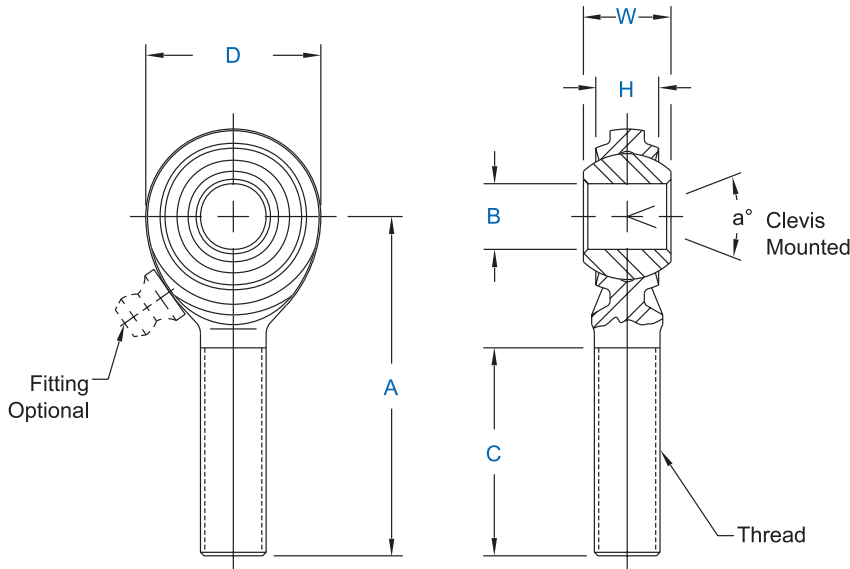

Specifications
Body - Carbon steel, protective coated for corrosion resistance.
Ball - Sintered steel, heat treated, oil impregnated.
Alternate Ball - Alloy steel, heat treated, hard chrome plated.

Rod End No.		DIMENSIONS IN INCHES								a° Misalign. Angle	Ultimate Radial Static Load Capacity Lbs.	Approx. Brg. Wt. Lbs.
Right Hand	Left Hand	B + .0025 - .0005	W ± .005	H Ref.	A ± .015	D Ref.	Ball Dia. Ref.	C + .062 - .031	Thread UNF-3A			
CM-3*	CB-3*	.1900	.312	.234	1.250	.625	.437	.750	10-32	20	1,204	.03
CM-4*	CB-4*	.2500	.375	.250	1.562	.750	.500	1.000	1/4-28	27	2,212	.04
CM-5*	CB-5*	.3125	.437	.312	1.875	.875	.625	1.250	5/16-24	22	3,577	.07
CM-6	CB-6	.3750	.500	.359	1.938	1.000	.719	1.250	3/8-24	22	5,068	.11
CM-7	CB-7	.4375	.562	.406	2.125	1.125	.812	1.375	7/16-20	21	6,345	.15
CM-8	CB-8	.5000	.625	.453	2.438	1.312	.937	1.500	1/2-20	20	8,338	.24
CM-10	CB-10	.6250	.750	.484	2.625	1.500	1.125	1.625	5/8-18	26	9,713	.36
CM-12	CB-12	.7500	.875	.593	2.875	1.750	1.312	1.750	3/4-16	24	14,207	.57

Rod End No.		DIMENSIONS IN MILLIMETERS								a° Misalign. Angle	Ultimate Radial Static Load Capacity Newtons	Approx. Brg. Wt. Grams
Right Hand	Left Hand	B + .064 - .013	W ± .13	H Ref.	A ± .38	D Ref.	Ball Dia. Ref.	C +1.57 - .79	Thread UNF-3A			
CM-3*	CB-3*	4.826	7.92	5.94	31.75	15.88	11.10	19.05	10-32	20	5,355	14
CM-4*	CB-4*	6.350	9.53	6.35	39.67	19.05	12.70	25.40	1/4-28	27	9,839	18
CM-5*	CB-5*	7.938	11.10	7.92	47.63	22.23	15.88	31.75	5/16-24	22	15,910	32
CM-6	CB-6	9.525	12.70	9.12	49.23	25.40	18.26	31.75	3/8-24	22	22,542	50
CM-7	CB-7	11.113	14.27	10.31	53.98	28.58	20.62	34.93	7/16-20	21	28,223	68
CM-8	CB-8	12.700	15.88	11.50	61.93	33.32	23.80	38.10	1/2-20	20	37,087	109
CM-10	CB-10	15.875	19.05	12.29	66.68	38.10	28.58	41.28	5/8-18	26	43,203	163
CM-12	CB-12	19.050	22.23	15.06	73.03	44.45	33.32	44.45	3/4-16	24	63,193	259

Load ratings apply only to rod ends without grease fittings.
For load ratings with fittings, please consult our engineering department.

* Grease fittings not available on these sizes. Units are supplied without grease fittings. When a grease fitting is required, specify by adding suffix as designated.

Z Zerk type fitting Ex: CM-6Z
F Flush type fitting Ex: CM-6F



CW & CG Series Female Rod Ends

General Purpose - Economy

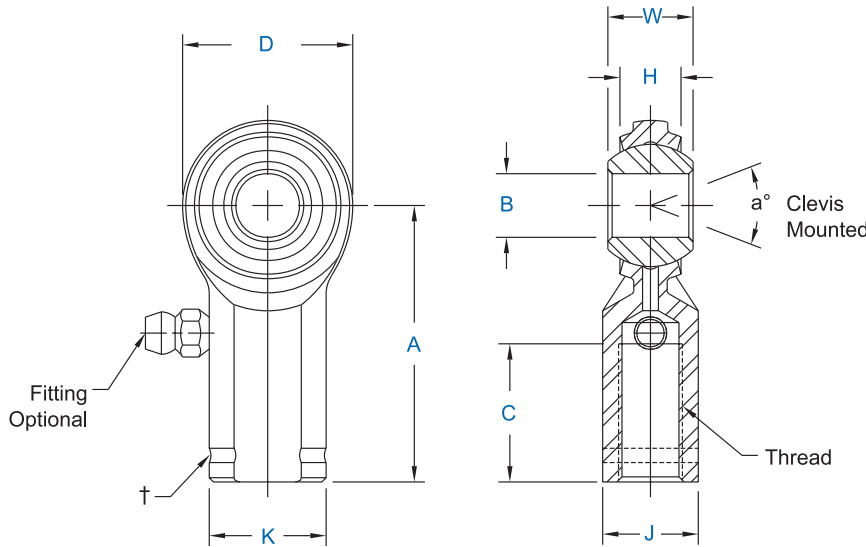

Specifications
Body - Carbon steel, protective coated for corrosion resistance.
Ball - Sintered steel, heat treated, oil impregnated.
Alternate Ball - Alloy steel, heat treated, hard chrome plated.

Rod End No.		DIMENSIONS IN INCHES										a° Misalign. Angle	Ultimate Radial Static Load Capacity Lbs.	Approx. Brg. Wt. Lbs.
Right Hand	Left Hand†	B + .0025 - .0005	W ± .005	H Ref.	A ± .015	D Ref.	K ± .010	J ± .010	Ball Dia. Ref.	C + .062 - .031	Thread UNF-2B			
CW-3*	CG-3*	.1900	.312	.234	1.062	.625	.406	.312	.437	.500	10-32	20	2,079	.04
CW-4	CG-4	.2500	.375	.250	1.312	.750	.469	.375	.500	.687	1/4-28	27	3,208	.05
CW-5	CG-5	.3125	.437	.312	1.375	.875	.500	.437	.625	.687	5/16-24	22	3,824	.08
CW-6	CG-6	.3750	.500	.359	1.625	1.000	.687	.562	.719	.812	3/8-24	22	5,087	.13
CW-7	CG-7	.4375	.562	.406	1.812	1.125	.750	.625	.812	.937	7/16-20	21	6,385	.18
CW-8	CG-8	.5000	.625	.453	2.125	1.312	.875	.750	.937	1.062	1/2-20	20	9,096	.29
CW-10	CG-10	.6250	.750	.484	2.500	1.500	1.000	.875	1.125	1.375	5/8-18	26	9,713	.43
CW-12	CG-12	.7500	.875	.593	2.875	1.750	1.125	1.000	1.312	1.562	3/4-16	24	14,207	.65

Rod End No.		DIMENSIONS IN MILLIMETERS										a° Misalign. Angle	Ultimate Radial Static Load Capacity Newtons	Approx. Brg. Wt. Grams
Right Hand	Left Hand†	B + .064 - .013	W ± .13	H Ref.	A ± .38	D Ref.	K ± .25	J ± .25	Ball Dia. Ref.	C +1.57 - .79	Thread UNF-2B			
CW-3*	CG-3*	4.826	7.92	5.94	26.97	15.88	10.31	7.92	11.10	12.70	10-32	20	9,247	18
CW-4	CG-4	6.350	9.53	6.35	33.32	19.05	11.91	9.53	12.70	17.45	1/4-28	27	14,269	23
CW-5	CG-5	7.938	11.10	7.92	34.93	22.23	12.70	11.10	15.88	17.45	5/16-24	22	17,009	36
CW-6	CG-6	9.525	12.70	9.12	41.28	25.40	17.45	14.27	18.26	20.62	3/8-24	22	22,627	59
CW-7	CG-7	11.113	14.27	10.31	46.02	28.58	19.05	15.88	20.62	23.80	7/16-20	21	28,400	82
CW-8	CG-8	12.700	15.88	11.50	53.98	33.32	22.23	19.05	23.80	26.97	1/2-20	20	40,459	132
CW-10	CG-10	15.875	19.05	12.29	63.50	38.10	25.40	22.23	28.58	34.93	5/8-18	26	43,203	195
CW-12	CG-12	19.050	22.23	15.06	73.03	44.45	28.58	25.40	33.32	39.67	3/4-16	24	63,193	295

†Left hand units have identification groove near end of shank.

* Grease fittings not available on these sizes. Units are supplied without grease fittings. When a grease fitting is required, specify by adding suffix as designated.

Z Zerk type fitting Ex: CW-6Z
F Flush type fitting Ex: CW-6F



VCM & VCB Series Male Rod Ends

General Purpose - Economy - Self-Lubricating

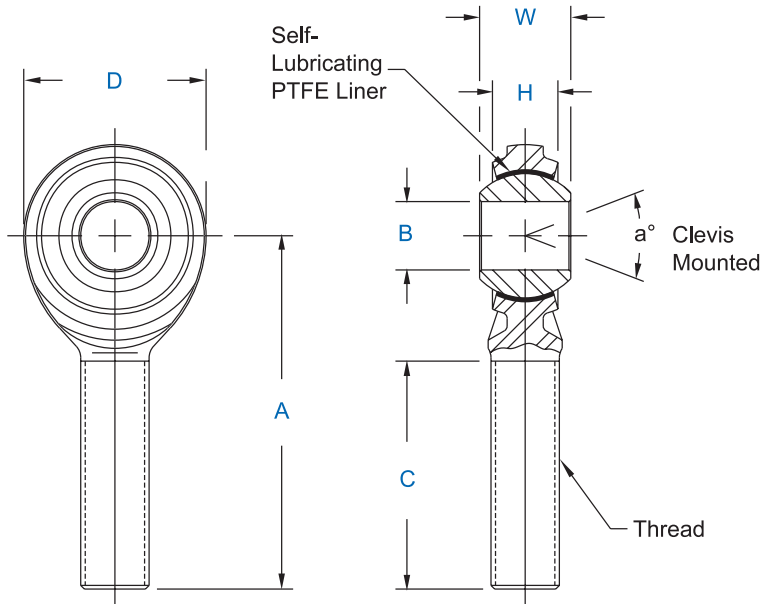

Specifications	
Body	Carbon steel, protective coated for corrosion resistance, PTFE lined.
Ball	Sintered steel, heat treated, oil impregnated.
Alternate Ball	Alloy steel, heat treated, hard chrome plated.

Rod End No.		DIMENSIONS IN INCHES								a° Misalign. Angle	Ultimate Radial Static Load Capacity Lbs.	Approx. Brg. Wt. Lbs.
Right Hand	Left Hand	B + .0025 - .0005	W ± .005	H Ref.	A ± .015	D Ref.	Ball Dia. Ref.	C + .062 - .031	Thread UNF-3A			
VCM-5	VCB-5	.3125	.437	.312	1.875	.875	.593	1.250	5/16-24	22	2,623	.07
VCM-6	VCB-6	.3750	.500	.359	1.938	1.000	.687	1.250	3/8-24	22	3,643	.11
VCM-7	VCB-7	.4375	.562	.406	2.125	1.125	.781	1.375	7/16-20	21	4,464	.15
VCM-8	VCB-8	.5000	.625	.453	2.438	1.312	.875	1.500	1/2-20	20	7,229	.24
VCM-10	VCB-10	.6250	.750	.484	2.625	1.500	1.062	1.625	5/8-18	26	8,204	.36
VCM-12	VCB-12	.7500	.875	.593	2.875	1.750	1.250	1.750	3/4-16	24	12,280	.57

Rod End No.		DIMENSIONS IN MILLIMETERS								a° Misalign. Angle	Ultimate Radial Static Load Capacity Newtons	Approx. Brg. Wt. Grams
Right Hand	Left Hand	B + .064 - .013	W ± .13	H Ref.	A ± .38	D Ref.	Ball Dia. Ref.	C +1.57 - .79	Thread UNF-3A			
VCM-5	VCB-5	7.938	11.10	7.92	47.63	22.23	15.06	31.75	5/16-24	22	11,667	32
VCM-6	VCB-6	9.525	12.70	9.12	49.23	25.40	17.45	31.75	3/8-24	22	16,204	50
VCM-7	VCB-7	11.113	14.27	10.31	53.98	28.58	19.84	34.93	7/16-20	21	19,856	68
VCM-8	VCB-8	12.700	15.88	11.50	61.93	33.32	22.23	38.10	1/2-20	20	32,155	109
VCM-10	VCB-10	15.875	19.05	12.29	66.68	38.10	26.97	41.28	5/8-18	26	36,491	163
VCM-12	VCB-12	19.050	22.23	15.06	73.03	44.45	31.75	44.45	3/4-16	24	54,621	259



VCW & VCG Series Female Rod Ends

General Purpose - Economy - Self-Lubricating

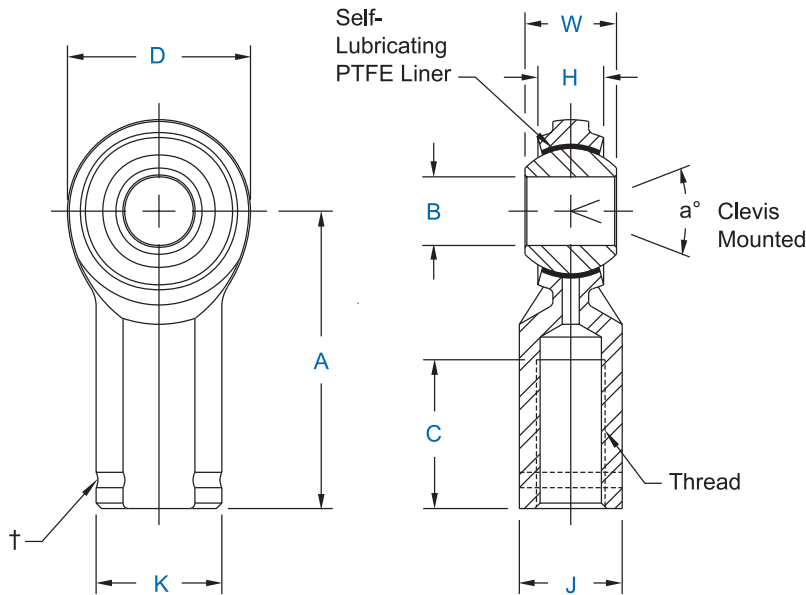

Specifications	
Body - Carbon steel, protective coated for corrosion resistance, PTFE lined.	
Ball - Sintered steel, heat treated, oil impregnated.	
Alternate Ball - Alloy steel, heat treated, hard chrome plated.	

Rod End No.		DIMENSIONS IN INCHES										a° Misalign. Angle	Ultimate Radial Static Load Capacity Lbs.	Approx. Brg. Wt. Lbs.
Right Hand	Left Hand†	B +.0025 -.0005	W ± .005	H Ref.	A ± .015	D Ref.	K ± .010	J ± .010	Ball Dia. Ref.	C +.062 -.031	Thread UNF-2B			
VCW-5	VCG-5	.3125	.437	.312	1.375	.875	.500	.437	.593	.687	5/16-24	22	2,623	.08
VCW-6	VCG-6	.3750	.500	.359	1.625	1.000	.687	.562	.687	.812	3/8-24	22	3,643	.13
VCW-7	VCG-7	.4375	.562	.406	1.812	1.125	.750	.625	.781	.937	7/16-20	21	4,464	.18
VCW-8	VCG-8	.5000	.625	.453	2.125	1.312	.875	.750	.875	1.062	1/2-20	20	7,229	.29
VCW-10	VCG-10	.6250	.750	.484	2.500	1.500	1.000	.875	1.062	1.375	5/8-18	26	8,204	.43
VCW-12	VCG-12	.7500	.875	.593	2.875	1.750	1.125	1.000	1.250	1.562	3/4-16	24	12,280	.65

Rod End No.		DIMENSIONS IN MILLIMETERS										a° Misalign. Angle	Ultimate Radial Static Load Capacity Newtons	Approx. Brg. Wt. Grams
Right Hand	Left Hand†	B +.064 -.013	W ± .13	H Ref.	A ± .38	D Ref.	K ± .25	J ± .25	Ball Dia. Ref.	C +1.57 -.79	Thread UNF-2B			
VCW-5	VCG-5	7.938	11.10	7.92	34.93	22.23	12.70	11.10	15.06	17.45	5/16-24	22	11,667	36
VCW-6	VCG-6	9.525	12.70	9.12	41.28	25.40	17.45	14.27	17.45	20.62	3/8-24	22	16,204	59
VCW-7	VCG-7	11.113	14.27	10.31	46.02	28.58	19.05	15.88	19.84	23.80	7/16-20	21	19,856	82
VCW-8	VCG-8	12.700	15.88	11.50	53.98	33.32	22.23	19.05	22.23	26.97	1/2-20	20	32,155	132
VCW-10	VCG-10	15.875	19.05	12.29	63.50	38.10	25.40	22.23	26.97	34.93	5/8-18	26	36,491	195
VCW-12	VCG-12	19.050	22.23	15.06	73.03	44.45	28.58	25.40	31.75	39.67	3/4-16	24	54,621	295

† Left-hand units have identification groove near end of shank.



MM & MB Series Male Rod Ends

General Purpose - Precision

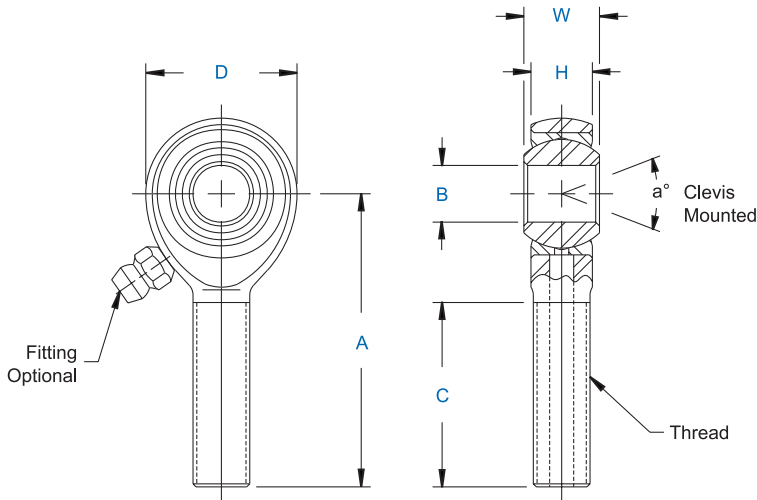

Specifications		
Body	Carbon steel protective coated for corrosion resistance. No. 16 series standard body is alloy steel not heat treated.	
Race	Carbon steel, protective coated for corrosion resistance.	
Ball	Alloy steel, heat treated, hard chrome plated.	
Notes		
Drilled hole in shank not available in 2,3,4,5,14 and 16 bore sizes. All sizes available with studs upon request.		

Rod End No.		DIMENSIONS IN INCHES								a° Misalign. Angle	Ultimate Radial Static Load Capacity Lbs.	Approx. Brg. Wt. Lbs.	
Right Hand	Left Hand	B + .0015 - .0005	W + .000 - .005	H ± .005	A ± .015	D ± .010	Ball Dia. Ref.	C + .062 - .031	Thread UNF-3A				
**	MM-2	MB-2	.1250	.250	.187	.937	.500	.312	.562	6-32 ¹	16	502	.013
	MM-3	MB-3	.1900	.312	.250	1.250	.625	.437	.750	10-32	13	1,169	.028
	MM-4	MB-4	.2500	.375	.281	1.562	.750	.500	1.000	1/4-28	16	2,158	.043
	MM-5	MB-5	.3125	.437	.344	1.875	.875	.625	1.250	5/16-24	14	2,784	.072
	MM-6	MB-6	.3750	.500	.406	1.938	1.000	.719	1.250	3/8-24	12	3,915	.112
	MM-7	MB-7	.4375	.562	.437	2.125	1.125	.812	1.375	7/16-20	14	4,218	.160
	MM-8	MB-8	.5000	.625	.500	2.438	1.312	.937	1.500	1/2-20	12	6,660	.249
	MM-10	MB-10	.6250	.750	.562	2.625	1.500	1.125	1.625	5/8-18	16	7,364	.382
	MM-12	MB-12	.7500	.875	.687	2.875	1.750	1.312	1.750	3/4-16	14	11,518	.602
*	MM-14	MB-14	.8750	.875	.765	3.375	2.000	1.375	2.000	7/8-14	7	18,476	.906
*	MM-14-1	MB-14-1	.8750	.875	.687	3.375	2.000	1.312	1.875	7/8-14	12	22,843	.906
3	MM-16	MB-16	1.0000	1.375	1.000	4.125	2.750	1.875	2.125	1 1/4-12	17	43,541	2.406
3	MM-16-1	MB-16-1	1.0000	1.375	1.000	4.125	2.750	1.875	2.125	1-14 ²	17	43,541	2.127
3	MM-16-2	MB-16-2	1.0000	1.375	1.000	4.125	2.750	1.875	2.125	1-12	17	43,541	2.127

Rod End No.		DIMENSIONS IN MILLIMETERS								a° Misalign. Angle	Ultimate Radial Static Load Capacity Newtons	Approx. Brg. Wt. Grams	
Right Hand	Left Hand	B + .038 - .013	W + .00 - .13	H ± .13	A ± .38	D ± .25	Ball Dia. Ref.	C + 1.57 - .79	Thread UNF-3A				
**	MM-2	MB-2	3.175	6.35	4.75	23.80	12.70	7.92	14.27	6-32 ¹	16	2,236	6
	MM-3	MB-3	4.826	7.92	6.35	31.75	15.88	11.10	19.05	10-32	13	5,197	13
	MM-4	MB-4	6.350	9.53	7.14	39.67	19.05	12.70	25.40	1/4-28	16	9,600	20
	MM-5	MB-5	7.938	11.10	8.74	47.63	22.23	15.88	31.75	5/16-24	14	12,385	33
	MM-6	MB-6	9.525	12.70	10.31	49.23	25.40	18.26	31.75	3/8-24	12	17,416	51
	MM-7	MB-7	11.113	14.27	11.10	53.98	28.58	20.62	34.93	7/16-20	14	18,759	73
	MM-8	MB-8	12.700	15.88	12.70	61.93	33.32	23.80	38.10	1/2-20	12	29,624	113
	MM-10	MB-10	15.875	19.05	14.27	66.68	38.10	28.58	41.28	5/8-18	16	32,752	173
	MM-12	MB-12	19.050	22.23	17.45	73.03	44.45	33.32	44.45	3/4-16	14	51,237	273
*	MM-14	MB-14	22.225	22.23	19.43	85.73	50.80	34.93	50.80	7/8-14	7	82,185	411
*	MM-14-1	MB-14-1	22.225	22.23	17.45	85.73	50.80	33.32	47.63	7/8-14	12	101,601	411
4	MM-16	MB-16	25.400	34.93	25.40	104.78	69.85	47.63	53.98	1 1/4-12	17	193,670	1,091
4	MM-16-1	MB-16-1	25.400	34.93	25.40	104.78	69.85	47.63	53.98	1-14 ²	17	193,670	965
4	MM-16-2	MB-16-2	25.400	34.93	25.40	104.78	69.85	47.63	53.98	1-12	17	193,670	965

* Check availability.
 ** Grease fitting not available.
 1 Threads 6-32 UNC.
 2 Threads 1-14 UNS.
 3 Tolerance variation: "D" ± .020, "A" ± .020, "B" + .0035, - .0005, "H" ± .010
 4 Tolerance variation: "D" ± .51, "A" ± .51, "B" + .089, - .013, "H" ± .25

Units are supplied without grease fittings. When grease fittings are required, specify by adding suffixes as designated.
 Z Zerk type fitting Ex: MM-6Z
 F Flush type fitting Ex: MM-6F
 Load ratings apply only to rod ends without grease fittings. For load ratings with fittings, please consult our engineering department.
Solid shank add suffix "Y", Ex: MM - 6Y.



MW & MG Series Female Rod Ends

General Purpose - Precision

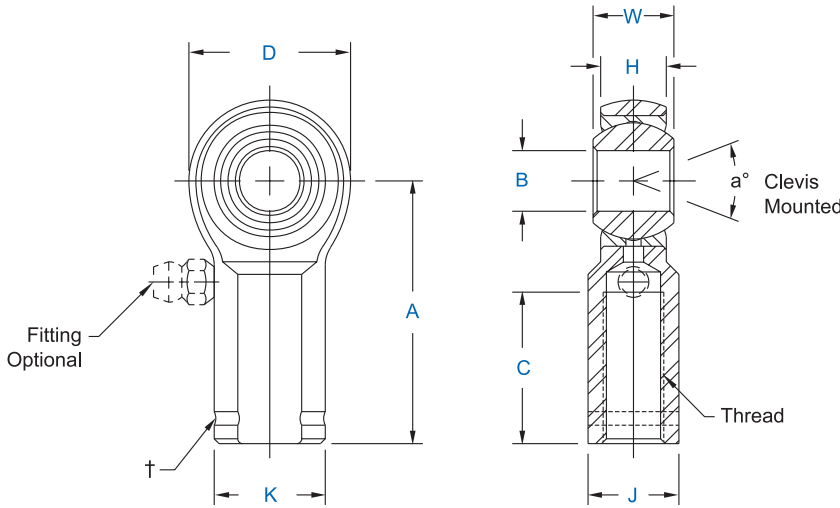

Specifications	
Body	Carbon steel protective coated for corrosion resistance. No. 16 series standard body is alloy steel not heat treated.
Race	Carbon steel, protective coated for corrosion resistance.
Ball	Alloy steel, heat treated, hard chrome plated.
Notes	
All sizes available with studs upon request.	

Rod End No.		DIMENSIONS IN INCHES										a° Misalign. Angle	Ultimate Radial Static Load Capacity Lbs.	Approx. Brg. Wt. Lbs.	
Right Hand	Left Hand†	B + .0015 - .0005	W + .000 - .005	H ± .005	A ± .015	D ± .010	K ± .010	J ± .010	Ball Dia. Ref.	C + .062 - .031	Thread UNF-2B				
**	MW-2	MG-2	.1250	.250	.187	.812	.500	.312	.250	.312	.437	6-32 ¹	16	1,202	.019
	MW-3	MG-3	.1900	.312	.250	1.062	.625	.406	.312	.437	.562	10-32	13	1,531	.038
	MW-4	MG-4	.2500	.375	.281	1.312	.750	.469	.375	.500	.750	1/4-28	16	2,539	.059
	MW-5	MG-5	.3125	.437	.344	1.375	.875	.500	.437	.625	.750	5/16-24	14	3,133	.092
	MW-6	MG-6	.3750	.500	.406	1.625	1.000	.687	.562	.719	.937	3/8-24	12	3,915	.152
	MW-7	MG-7	.4375	.562	.437	1.812	1.125	.750	.625	.812	1.062	7/16-20	14	4,218	.198
	MW-8	MG-8	.5000	.625	.500	2.125	1.312	.875	.750	.937	1.187	1/2-20	12	6,660	.329
	MW-10	MG-10	.6250	.750	.562	2.500	1.500	1.000	.875	1.125	1.500	5/8-18	16	7,364	.477
	MW-12	MG-12	.7500	.875	.687	2.875	1.750	1.125	1.000	1.312	1.750	3/4-16	14	11,518	.723
*	MW-14	MG-14	.8750	.875	.765	3.375	2.000	1.300	1.125	1.375	1.875	7/8-14	7	18,476	1.030
*	MW-14-1	MG-14-1	.8750	.875	.687	3.500	2.000	1.312	1.187	1.312	1.812	7/8-14	12	22,843	1.030
3	MW-16	MG-16	1.0000	1.375	1.000	4.125	2.750	1.625	1.500	1.875	2.125	1 1/4-12	17	40,889	2.125
3	MW-16-1	MG-16-1	1.0000	1.375	1.000	4.125	2.750	1.625	1.500	1.875	1-14 ²	17	43,541	2.410	
3	MW-16-2	MG-16-2	1.0000	1.375	1.000	4.125	2.750	1.625	1.500	1.875	1-12	17	43,541	2.410	

Rod End No.		DIMENSIONS IN MILLIMETERS										a° Misalign. Angle	Ultimate Radial Static Load Capacity Newtons	Approx. Brg. Wt. Grams	
Right Hand	Left Hand†	B + .038 - .013	W + .00 - .13	H ± .13	A ± .38	D ± .25	K ± .25	J ± .25	Ball Dia. Ref.	C +1.57 -.79	Thread UNF-2B				
**	MW-2	MG-2	3.175	6.35	4.75	20.62	12.70	7.92	6.35	7.92	11.10	6-32 ¹	16	5,344	9
	MW-3	MG-3	4.826	7.92	6.35	26.97	15.88	10.31	7.92	11.10	14.27	10-32	13	6,805	17
	MW-4	MG-4	6.350	9.53	7.14	33.32	19.05	11.91	9.53	12.70	19.05	1/4-28	16	11,297	27
	MW-5	MG-5	7.938	11.10	8.74	34.93	22.23	12.70	11.10	15.88	19.05	5/16-24	14	13,934	42
	MW-6	MG-6	9.525	12.70	10.31	41.28	25.40	17.45	14.27	18.26	23.80	3/8-24	12	17,416	69
	MW-7	MG-7	11.113	14.27	11.10	46.02	28.58	19.05	15.88	20.62	26.97	7/16-20	14	18,759	90
	MW-8	MG-8	12.700	15.88	12.70	53.98	33.32	22.23	19.05	23.80	30.15	1/2-20	12	29,624	149
	MW-10	MG-10	15.875	19.05	14.27	63.50	38.10	25.40	22.23	28.58	38.10	5/8-18	16	32,752	216
	MW-12	MG-12	19.050	22.23	17.45	73.03	44.45	28.58	25.40	33.32	44.45	3/4-16	14	51,237	328
*	MW-14	MG-14	22.225	22.23	19.43	85.73	50.80	33.02	28.58	34.93	47.63	7/8-14	7	82,185	467
*	MW-14-1	MG-14-1	22.225	22.23	17.45	88.90	50.80	33.32	30.15	33.32	46.02	7/8-14	12	101,601	467
4	MW-16	MG-16	25.400	34.93	25.40	104.78	69.85	41.28	38.10	47.63	53.98	1 1/4-12	17	193,670	964
4	MW-16-1	MG-16-1	25.400	34.93	25.40	104.78	69.85	41.28	38.10	47.63	53.98	1-14 ²	17	193,670	1,093
4	MW-16-2	MG-16-2	25.400	34.93	25.40	104.78	69.85	41.28	38.10	47.63	53.98	1-12	17	193,670	1,093

* Check for availability

† Left hand units have identification groove near end of shank

1Threads 6-32 UNC

2Threads 1-14 UNS

3Tolerance variation: "D" ± .020, "A" ± .020 "B" + .0035, - .0005, "H" ± .010, "K" ± .015, "J" ± .015

4Tolerance variation: "D" ± .51, "A" ± .51 "B" + .089, -.013, "H" ± .25, "K" ± .38, "J" ± .38

** Grease fitting not available.

Units are supplied without grease fittings. When a grease fitting is required, specify by adding suffix as designated.

Z Zerk type fitting

Ex: MW-6Z

F Flush type fitting

Ex: MW-6F



MM-T & MB-T Series
Male Rod Ends (PTFE) Lined
 General Purpose - Precision - Self-Lubricating

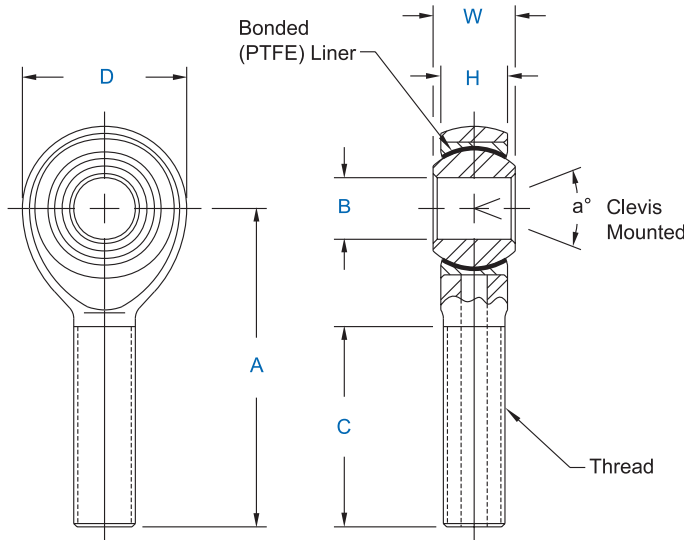

Specifications	
Body	Carbon steel protective coated for corrosion resistance. No. 16 series standard body is alloy steel not heat treated.
Race	Carbon steel, protective coated for corrosion resistance, PTFE lined.
Ball	Alloy steel, heat treated, hard chrome plated.
Notes	
Drilled hole in shank not available in 2,3,4,5,14 and 16 bore sizes. All sizes available with studs upon request.	

Rod End No.		DIMENSIONS IN INCHES								a° Misalign. Angle	Ultimate Radial Static Load Capacity Lbs.	Approx. Brg. Wt. Lbs.
Right Hand	Left Hand	B + .0015 - .0005	W + .000 - .005	H ± .005	A ± .015	D ± .010	Ball Dia. Ref.	C + .062 - .031	Thread UNF-3A			
MM-3T	MB-3T	.1900	.312	.250	1.250	.625	.437	.750	10-32	13	1,169	.028
MM-4T	MB-4T	.2500	.375	.281	1.562	.750	.500	1.000	1/4-28	16	2,158	.043
MM-5T	MB-5T	.3125	.437	.344	1.875	.875	.625	1.250	5/16-24	14	2,784	.072
MM-6T	MB-6T	.3750	.500	.406	1.938	1.000	.719	1.250	3/8-24	12	3,915	.112
MM-7T	MB-7T	.4375	.562	.437	2.125	1.125	.812	1.375	7/16-20	14	4,218	.160
MM-8T	MB-8T	.5000	.625	.500	2.438	1.312	.937	1.500	1/2-20	12	6,660	.249
MM-10T	MB-10T	.6250	.750	.562	2.625	1.500	1.125	1.625	5/8-18	16	7,364	.382
MM-12T	MB-12T	.7500	.875	.687	2.875	1.750	1.312	1.750	3/4-16	14	11,518	.602
* MM-14T	MB-14T	.8750	.875	.765	3.375	2.000	1.375	2.000	7/8-14	7	18,476	.906
1 MM-16T	MB-16T	1.0000	1.375	1.000	4.125	2.750	1.875	2.125	1 1/4-12	17	43,541	2.406
1 MM-16T-1	MB-16T-1	1.0000	1.375	1.000	4.125	2.750	1.875	2.125	1-14 ³	17	43,541	2.127
1 MM-16T-2	MB-16T-2	1.0000	1.375	1.000	4.125	2.750	1.875	2.125	1-12	17	43,541	2.127

Rod End No.		DIMENSIONS IN MILLIMETERS								a° Misalign. Angle	Ultimate Radial Static Load Capacity Newtons	Approx. Brg. Wt. Grams
Right Hand	Left Hand	B + .038 - .013	W + .00 - .13	H ± .13	A ± .38	D ± .25	Ball Dia. Ref.	C + 1.57 - .79	Thread UNF-3A			
MM-3T	MB-3T	4.826	7.92	6.35	31.75	15.88	11.10	19.05	10-32	13	5,197	13
MM-4T	MB-4T	6.350	9.53	7.14	39.67	19.05	12.70	25.40	1/4-28	16	9,600	20
MM-5T	MB-5T	7.938	11.10	8.74	47.63	22.23	15.88	31.75	5/16-24	14	12,385	33
MM-6T	MB-6T	9.525	12.70	10.31	49.23	25.40	18.26	31.75	3/8-24	12	17,416	51
MM-7T	MB-7T	11.113	14.27	11.10	53.98	28.58	20.62	34.93	7/16-20	14	18,759	73
MM-8T	MB-8T	12.700	15.88	12.70	61.93	33.32	23.80	38.10	1/2-20	12	29,624	113
MM-10T	MB-10T	15.875	19.05	14.27	66.68	38.10	28.58	41.28	5/8-18	16	32,752	173
MM-12T	MB-12T	19.050	22.23	17.45	73.03	44.45	33.32	44.45	3/4-16	14	51,237	273
* MM-14T	MB-14T	22.225	22.23	19.43	85.73	50.80	34.93	50.80	7/8-14	7	82,185	411
2 MM-16T	MB-16T	25.400	34.93	25.40	104.78	69.85	47.63	53.98	1 1/4-12	17	193,670	1,091
2 MM-16T-1	MB-16T-1	25.400	34.93	25.40	104.78	69.85	47.63	53.98	1-14 ³	17	193,670	965
2 MM-16T-2	MB-16T-2	25.400	34.93	25.40	104.78	69.85	47.63	53.98	1-12	17	193,670	965

* Check availability.

1 Tolerance variation: "D" ± .020, "A" ± .020, "B" + .0035, - .0005, "H" ± .010

2 Tolerance variation: "D" ± .51, "A" ± .51, "B" + .089, - .013, "H" ± .25

3 Threads 1-14 UNS.

Load ratings apply only to rod ends without grease fittings. For load ratings with fittings, please consult our engineering department.

Solid shank add suffix "Y". Ex: MM - 6TY



MW-T & MG-T Series
Female Rod Ends (PTFE) Lined
 General Purpose - Precision - Self-Lubricating

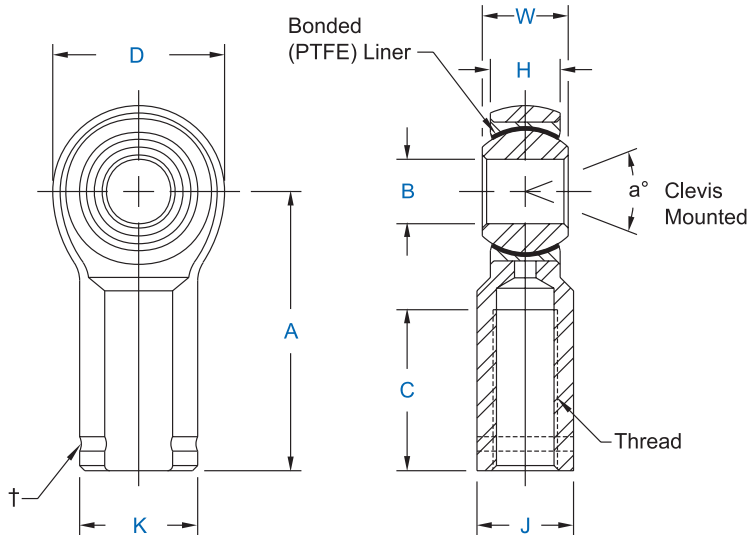

Specifications	
Body	Carbon steel protective coated for corrosion resistance. No. 16 series standard body is alloy steel not heat treated.
Race	Carbon steel, protective coated for corrosion resistance, PTFE lined.
Ball	Alloy steel, heat treated, hard chrome plated.
Notes	
All sizes available with studs upon request.	

Rod End No.		DIMENSIONS IN INCHES										a° Misalgn. Angle	Ultimate Radial Static Load Capacity Lbs.	Approx. Brg. Wt. Lbs.
Right Hand	Left Hand†	B + .0015 - .0005	W + .000 - .005	H ± .005	A ± .015	D ± .010	K ± .010	J ± .010	Ball Dia. Ref.	C + .062 - .031	Thread UNF-2B			
MW-3T	MG-3T	.1900	.312	.250	1.062	.625	.406	.312	.437	.562	10-32	13	1,531	.038
MW-4T	MG-4T	.2500	.375	.281	1.312	.750	.469	.375	.500	.750	1/4-28	16	2,539	.059
MW-5T	MG-5T	.3125	.437	.344	1.375	.875	.500	.437	.625	.750	5/16-24	14	3,133	.092
MW-6T	MG-6T	.3750	.500	.406	1.625	1.000	.687	.562	.719	.937	3/8-24	12	3,915	.152
MW-7T	MG-7T	.4375	.562	.437	1.812	1.125	.750	.625	.812	1.062	7/16-20	14	4,218	.198
MW-8T	MG-8T	.5000	.625	.500	2.125	1.312	.875	.750	.937	1.187	1/2-20	12	6,660	.329
MW-10T	MG-10T	.6250	.750	.562	2.500	1.500	1.000	.875	1.125	1.500	5/8-18	16	7,364	.477
MW-12T	MG-12T	.7500	.875	.687	2.875	1.750	1.125	1.000	1.312	1.750	3/4-16	14	11,518	.723
* 1	MW-14T	MG-14T	.8750	.875	.765	3.375	2.000	1.300	1.125	1.375	7/8-14	7	18,476	1.030
1	MW-16T	MG-16T	1.0000	1.375	1.000	4.125	2.750	1.625	1.500	1.875	1 1/4-12	17	40,889	2.125
1	MW-16T-1	MG-16T-1	1.0000	1.375	1.000	4.125	2.750	1.625	1.500	1.875	1-14 ³	17	43,541	2.410
1	MW-16T-2	MG-16T-2	1.0000	1.375	1.000	4.125	2.750	1.625	1.500	1.875	1-12	17	43,541	2.410

Rod End No.		DIMENSIONS IN MILLIMETERS										a° Misalgn. Angle	Ultimate Radial Static Load Capacity Newtons	Approx. Brg. Wt. Grams	
Right Hand	Left Hand†	B + .038 - .013	W + .00 - .13	H ± .13	A ± .38	D ± .25	K ± .25	J ± .25	Ball Dia. Ref.	C +1.57 - .79	Thread UNF-2B				
MW-3T	MG-3T	4.826	7.92	6.35	26.97	15.88	10.31	7.92	11.10	14.27	10-32	13	6,805	17	
MW-4T	MG-4T	6.350	9.53	7.14	33.32	19.05	11.91	9.53	12.70	19.05	1/4-28	16	11,297	27	
MW-5T	MG-5T	7.938	11.10	8.74	34.93	22.23	12.70	11.10	15.88	19.05	5/16-24	14	13,934	42	
MW-6T	MG-6T	9.525	12.70	10.31	41.28	25.40	17.45	14.27	18.26	23.80	3/8-24	12	17,416	69	
MW-7T	MG-7T	11.113	14.27	11.10	46.02	28.58	19.05	15.88	20.62	26.97	7/16-20	14	18,759	90	
MW-8T	MG-8T	12.700	15.88	12.70	53.98	33.32	22.23	19.05	23.80	30.15	1/2-20	12	29,624	149	
MW-10T	MG-10T	15.875	19.05	14.27	63.50	38.10	25.40	22.23	28.58	38.10	5/8-18	16	32,752	216	
MW-12T	MG-12T	19.050	22.23	17.45	73.03	44.45	28.58	25.40	33.32	44.45	3/4-16	14	51,237	328	
* 1	MW-14T	MG-14T	22.225	22.23	19.43	85.73	50.80	33.02	28.58	34.93	7/8-14	7	82,185	467	
2	MW-16T	MG-16T	25.400	34.93	25.40	104.78	69.85	41.28	38.10	47.63	53.98	1 1/4-12	17	181,874	964
2	MW-16T-1	MG-16T-1	25.400	34.93	25.40	104.78	69.85	41.28	38.10	47.63	53.98	1-14 ³	17	193,670	1,093
2	MW-16T-2	MG-16T-2	25.400	34.93	25.40	104.78	69.85	41.28	38.10	47.63	53.98	1-12	17	193,670	1,093

* Check for availability

† Left hand units have identification groove near end of shank.

1Tolerance variation: "D" ± .020, "A" ± .020 "B" + .0035, - .0005, "H" ± .010, "K" ± .015, "J" ± .015

2Tolerance variation: "D" ± .51, "A" ± .51 "B" + .089, -.013, "H" ± .25, "K" ± .38, "J" ± .38

3Threads 1-14 UNS



KM & KB Series Male Rod Ends

General Purpose - Precision - Wear Resistant

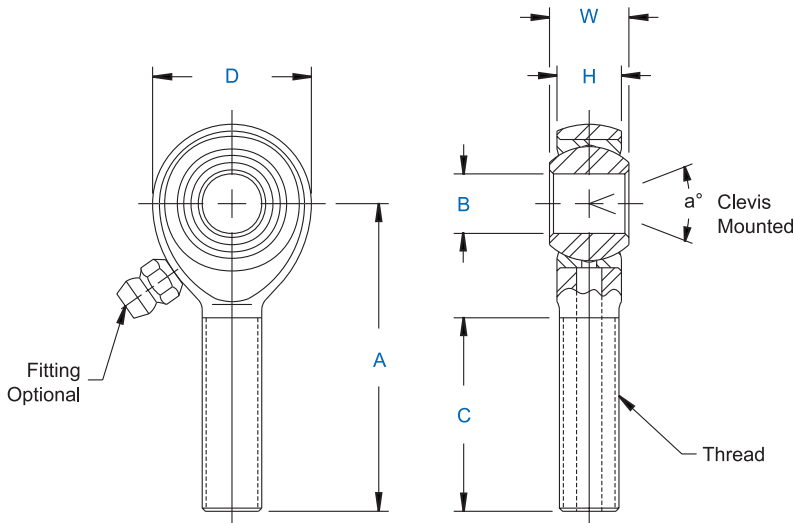

Specifications
Body - Carbon steel protective coated for corrosion resistance. No. 16 series standard body is alloy steel not heat treated.
Race - Alloy steel, heat treated, protective coated for corrosion resistance.
Ball - Alloy steel, heat treated, hard chrome plated.
Notes
Drilled hole in shank not available in 2,3,4,5,14 and 16 bore sizes. All sizes available with studs upon request.

Rod End No.		DIMENSIONS IN INCHES								a° Misalign. Angle	Ultimate Radial Static Load Capacity Lbs.	Approx. Brg. Wt. Lbs.	
		Right Hand	Left Hand	B + .0015 - .0005	W + .000	H ± .005	A ± .015	D ± .010	Ball Dia. Ref.				C + .062 - .031
	KM-3	KB-3	.1900	.312	.250	1.250	.625	.437	.750	10-32	13	1,169	.028
	KM-4	KB-4	.2500	.375	.281	1.562	.750	.500	1.000	1/4-28	16	2,158	.043
	KM-5	KB-5	.3125	.437	.344	1.875	.875	.625	1.250	5/16-24	14	2,784	.072
	KM-6	KB-6	.3750	.500	.406	1.938	1.000	.719	1.250	3/8-24	12	3,915	.112
	KM-7	KB-7	.4375	.562	.437	2.125	1.125	.812	1.375	7/16-20	14	4,218	.160
	KM-8	KB-8	.5000	.625	.500	2.438	1.312	.937	1.500	1/2-20	12	6,660	.249
	KM-10	KB-10	.6250	.750	.562	2.625	1.500	1.125	1.625	5/8-18	16	7,364	.382
	KM-12	KB-12	.7500	.875	.687	2.875	1.750	1.312	1.750	3/4-16	14	11,518	.602
*	KM-14	KB-14	.8750	.875	.765	3.375	2.000	1.375	2.000	7/8-14	7	18,476	.906
1	KM-16	KB-16	1.0000	1.375	1.000	4.125	2.750	1.875	2.125	1 1/4-12	17	43,541	2.406
1	KM-16-1	KB-16-1	1.0000	1.375	1.000	4.125	2.750	1.875	2.125	1-14 ³	17	43,541	2.127
1	KM-16-2	KB-16-2	1.0000	1.375	1.000	4.125	2.750	1.875	2.125	1-12	17	43,541	2.127

Rod End No.		DIMENSIONS IN MILLIMETERS								a° Misalign. Angle	Ultimate Radial Static Load Capacity Newtons	Approx. Brg. Wt. Grams	
		Right Hand	Left Hand	B + .038 - .013	W + .00	H ± .13	A ± .38	D ± .25	Ball Dia. Ref.				C + 1.57 - .79
	KM-3	KB-3	4.826	7.92	6.35	31.75	15.88	11.10	19.05	10-32	13	5,197	13
	KM-4	KB-4	6.350	9.53	7.14	39.67	19.05	12.70	25.40	1/4-28	16	9,600	20
	KM-5	KB-5	7.938	11.10	8.74	47.63	22.23	15.88	31.75	5/16-24	14	12,385	33
	KM-6	KB-6	9.525	12.70	10.31	49.23	25.40	18.26	31.75	3/8-24	12	17,416	51
	KM-7	KB-7	11.113	14.27	11.10	53.98	28.58	20.62	34.93	7/16-20	14	18,759	73
	KM-8	KB-8	12.700	15.88	12.70	61.93	33.32	23.80	38.10	1/2-20	12	29,624	113
	KM-10	KB-10	15.875	19.05	14.27	66.68	38.10	28.58	41.28	5/8-18	16	32,752	173
	KM-12	KB-12	19.050	22.23	17.45	73.03	44.45	33.32	44.45	3/4-16	14	51,237	273
*	KM-14	KB-14	22.225	22.23	19.43	85.73	50.80	34.93	50.80	7/8-14	7	82,185	411
2	KM-16	KB-16	25.400	34.93	25.40	104.78	69.85	47.63	53.98	1 1/4-12	17	193,670	1,091
2	KM-16-1	KB-16-1	25.400	34.93	25.40	104.78	69.85	47.63	53.98	1-14 ³	17	193,670	965
2	KM-16-2	KB-16-2	25.400	34.93	25.40	104.78	69.85	47.63	53.98	1-12	17	193,670	965

* Check for availability.

1 Tolerance variation: "D" ± .020, "A" ± .020, "B" + .0035, - .0005, "H" ± .010

2 Tolerance variation: "D" ± .51, "A" ± .51, "B" + .089, - .013, "H" ± .25

3 Threads 1-14 UNS.

Units are supplied without grease fittings. When a grease fitting is required, specify by adding suffix as designated.

Z Zerk type fitting Ex: KM-6Z

F Flush type fitting Ex: KM-6F

Load ratings apply only to rod ends without grease fittings. For load ratings with fittings, please consult our engineering department.

Solid shank add suffix "Y". Ex: KM - 6Y



KW & KG Series Female Rod Ends

General Purpose - Precision - Wear Resistant

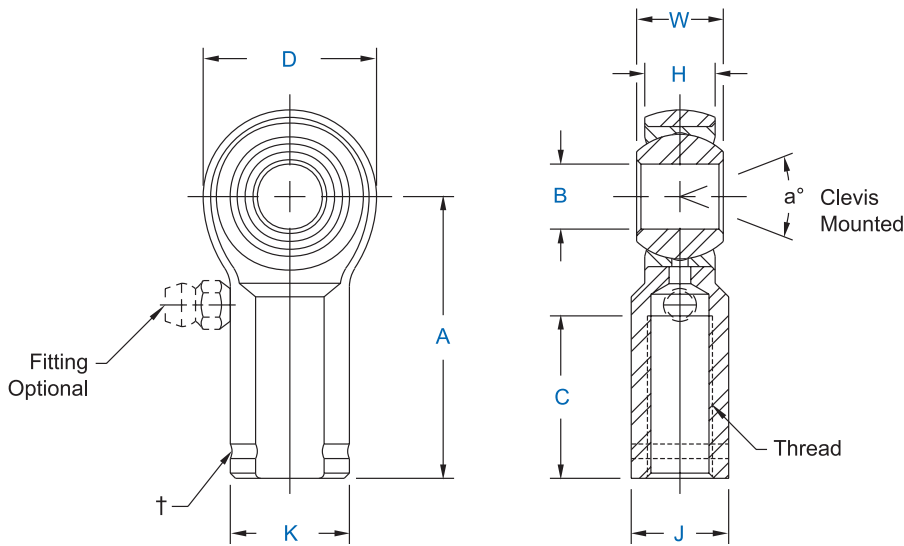

Specifications
Body - Carbon steel protective coated for corrosion resistance. No. 16 series standard body is alloy steel not heat treated.
Race - Alloy steel, heat treated, protective coated for corrosion resistance.
Ball - Alloy steel, heat treated, hard chrome plated.
Notes
All sizes available with studs upon request.

Rod End No.		DIMENSIONS IN INCHES										a° Misaln. Angle	Ultimate Radial Static Load Capacity Lbs.	Approx. Brg. Wt. Lbs.
Right Hand	Left Hand†	B + .0015 - .0005	W + .000 - .005	H ± .005	A ± .015	D ± .010	K ± .010	J ± .010	Ball Dia. Ref.	C + .062 - .031	Thread UNF-2B			
KW-3	KG-3	.1900	.312	.250	1.062	.625	.406	.312	.437	.562	10-32	13	1,531	.038
KW-4	KG-4	.2500	.375	.281	1.312	.750	.469	.375	.500	.750	1/4-28	16	2,539	.059
KW-5	KG-5	.3125	.437	.344	1.375	.875	.500	.437	.625	.750	5/16-24	14	3,133	.092
KW-6	KG-6	.3750	.500	.406	1.625	1.000	.687	.562	.719	.937	3/8-24	12	3,915	.152
KW-7	KG-7	.4375	.562	.437	1.812	1.125	.750	.625	.812	1.062	7/16-20	14	4,218	.198
KW-8	KG-8	.5000	.625	.500	2.125	1.312	.875	.750	.937	1.187	1/2-20	12	6,660	.329
KW-10	KG-10	.6250	.750	.562	2.500	1.500	1.000	.875	1.125	1.500	5/8-18	16	7,364	.477
KW-12	KG-12	.7500	.875	.687	2.875	1.750	1.125	1.000	1.312	1.750	3/4-16	14	11,518	.723
* KW-14	KG-14	.8750	.875	.765	3.375	2.000	1.300	1.125	1.375	1.875	7/8-14	7	18,476	1.030
1 KW-16	KG-16	1.0000	1.375	1.000	4.125	2.750	1.625	1.500	1.875	2.125	1 1/4-12	17	40,889	2.125
1 KW-16-1	KG-16-1	1.0000	1.375	1.000	4.125	2.750	1.625	1.500	1.875	2.125	1-14 ³	17	43,541	2.410
1 KW-16-2	KG-16-2	1.0000	1.375	1.000	4.125	2.750	1.625	1.500	1.875	2.125	1-12	17	43,541	2.410

Rod End No.		DIMENSIONS IN MILLIMETERS										a° Misaln. Angle	Ultimate Radial Static Load Capacity Newtons	Approx. Brg. Wt. Grams
Right Hand	Left Hand†	B + .038 - .013	W + .00 - .13	H ± .13	A ± .38	D ± .25	K ± .25	J ± .25	Ball Dia. Ref.	C +1.57 - .79	Thread UNF-2B			
KW-3	KG-3	4.826	7.92	6.35	26.97	15.88	10.31	7.92	11.10	14.27	10-32	13	6,805	17
KW-4	KG-4	6.350	9.53	7.14	33.32	19.05	11.91	9.53	12.70	19.05	1/4-28	16	11,297	27
KW-5	KG-5	7.938	11.10	8.74	34.93	22.23	12.70	11.10	15.88	19.05	5/16-24	14	13,934	42
KW-6	KG-6	9.525	12.70	10.31	41.28	25.40	17.45	14.27	18.26	23.80	3/8-24	12	17,416	69
KW-7	KG-7	11.113	14.27	11.10	46.02	28.58	19.05	15.88	20.62	26.97	7/16-20	14	18,759	90
KW-8	KG-8	12.700	15.88	12.70	53.98	33.32	22.23	19.05	23.80	30.15	1/2-20	12	29,624	149
KW-10	KG-10	15.875	19.05	14.27	63.50	38.10	25.40	22.23	28.58	38.10	5/8-18	16	32,752	216
KW-12	KG-12	19.050	22.23	17.45	73.03	44.45	28.58	25.40	33.32	44.45	3/4-16	14	51,237	328
* KW-14	KG-14	22.225	22.23	19.43	85.73	50.80	33.02	28.58	34.93	47.63	7/8-14	7	82,185	411
2 KW-16	KG-16	25.400	34.93	25.40	104.78	69.85	41.28	38.10	47.63	53.98	1 1/4-12	17	181,874	964
2 KW-16-1	KG-16-1	25.400	34.93	25.40	104.78	69.85	41.28	38.10	47.63	53.98	1-14 ³	17	193,670	1,093
2 KW-16-2	KG-16-2	25.400	34.93	25.40	104.78	69.85	41.28	38.10	47.63	53.98	1-12	17	193,670	1,093

* Check for availability.

† Left hand units have identification groove near end of shank.

1Tolerance variation: "D" ± .020, "A" ± .020 "B" + .0035, - .0005, "H" ± .010, "K" ± .015, "J" ± .015

2Tolerance variation: "D" ± .51, "A" ± .51 "B" + .089, -.013, "H" ± .25, "K" ± .38, "J" ± .38

3Threads 1-14 UNS

Units are supplied without grease fittings. When a grease fitting is required, specify by adding suffix as designated.

Z Zerk type fitting

Ex: KW-6Z

F Flush type fitting

Ex: KW-6F



Large Bore Series Male Rod Ends

General Purpose & High Strength - Precision - Wear Resistant
(PTFE Liners Available)

ROD ENDS

1 1/4", 1 1/2" & 2" sizes

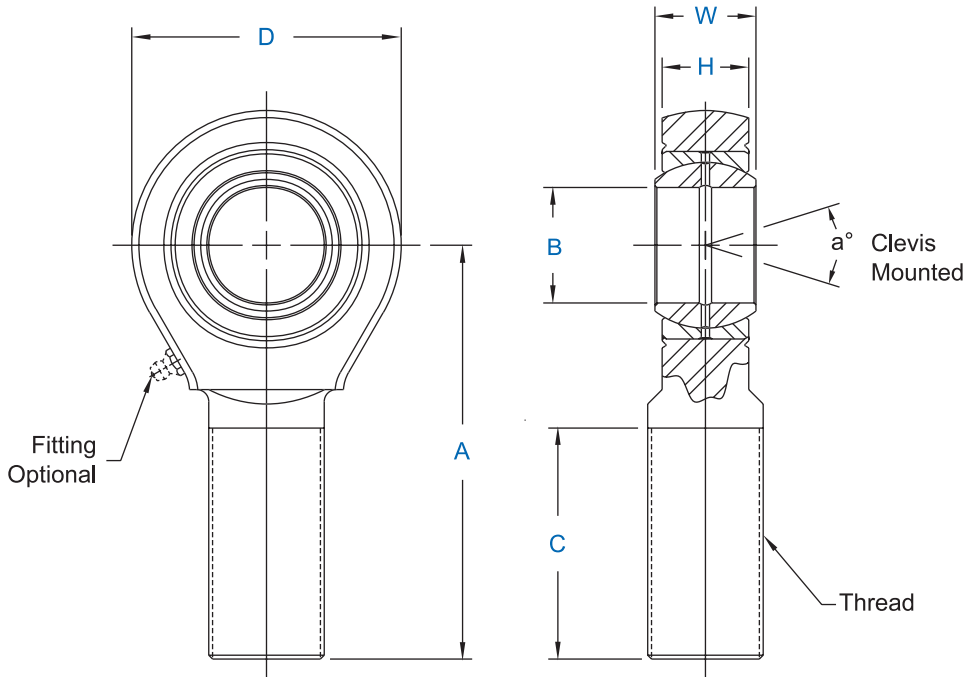

Specifications
Body (K-Series) - Alloy steel, protective coated for corrosion resistance.
Body (A-Series) - Alloy steel, heat treated, protective coated for corrosion resistance.
Race - 52100 steel, heat treated, protective coated for corrosion resistance.
Ball - 52100 steel, heat treated, protective coated for corrosion resistance.

K-Series -- Body Non Heat-Treated

Rod End No.		DIMENSIONS IN INCHES								a° Misalign. Angle	Ultimate Radial Static Load Capacity Lbs.	Approx. Brg. Wt. Lbs.
Right Hand	Left Hand	B +.0000 -.0005	W +.000 -.005	H ± .020	A ± .040	D ± .030	Ball Dia. Ref.	C +.062 -.031	Thread UNF-3A			
1 KM-20-1	KB-20-1	1.2500	1.093	.937	4.125	2.750	1.795	2.125	1 1/4-12	7.0	44,500	2.406
KM-24-1	KB-24-1	1.5000	1.312	1.125	5.375	3.500	2.155	3.000	1 1/2-12	6.5	64,770	4.75
KM-32-1	KB-32-1	2.0000	1.750	1.500	8.000	5.000	2.875	4.500	2-12 ²	6.0	153,528	14.25

A-Series -- Body Heat-Treated

Rod End No.		DIMENSIONS IN INCHES								a° Misalign. Angle	Ultimate Radial Static Load Capacity Lbs.	Approx. Brg. Wt. Lbs.
Right Hand	Left Hand	B +.0000 -.0005	W +.000 -.005	H ± .020	A ± .040	D ± .030	Ball Dia. Ref.	C +.062 -.031	Thread UNF-3A			
1 AM-20-1	AB-20-1	1.2500	1.093	.937	4.125	2.750	1.795	2.125	1 1/4-12	7.0	79,728	2.406
AM-24-1	AB-24-1	1.5000	1.312	1.125	5.375	3.500	2.155	3.000	1 1/2-12	6.5	138,826	4.75
AM-32-1	AB-32-1	2.0000	1.750	1.500	8.000	5.000	2.875	4.500	2-12 ²	6.0	378,955	14.25

1Tolerance variation: "H" ± .005
2Threads 2-12 UN-3A

Units are supplied without grease fittings. When a grease fitting is required, specify by adding suffix as designated.

- Z Zerk type fitting Ex: KM-24Z-1
- F Flush type fitting Ex: KM-24F-1
- T PTFE liner Ex: KM-24T-1

Load ratings apply only to rod ends without grease fittings. For load ratings with fittings, please consult our engineering department.



Large Bore Series Female Rod Ends
 General Purpose & High Strength - Precision - Wear Resistant
 (PTFE Liners Available)

ROD ENDS

1 1/4", 1 1/2" & 2" sizes

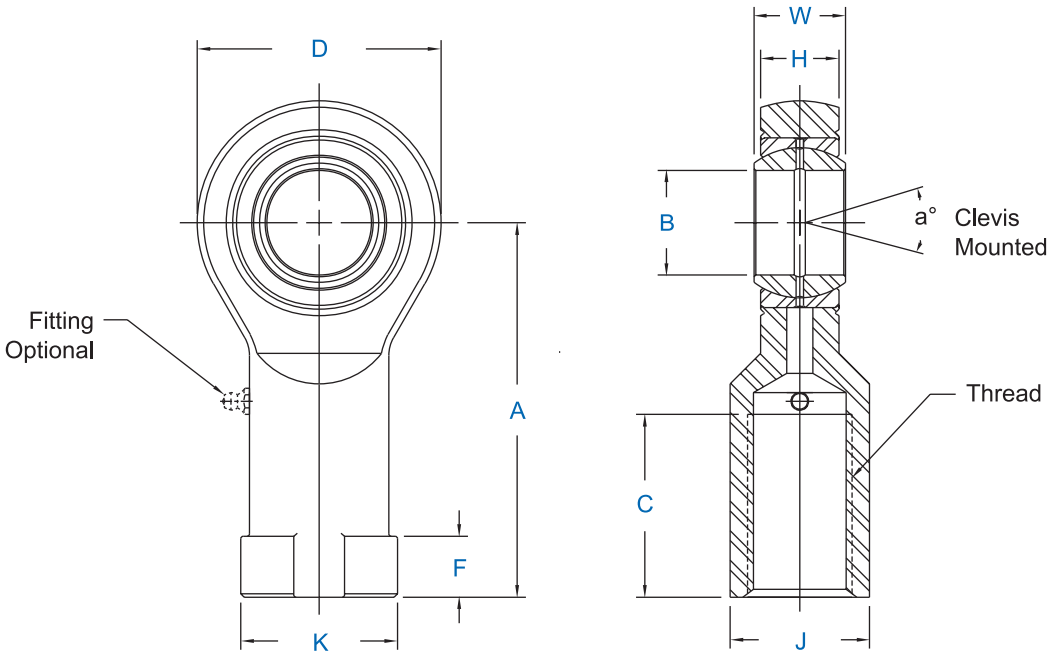

Specifications	
Body (K-Series) - Alloy steel, protective coated for corrosion resistance.	
Body (A-Series) - Alloy steel, heat treated, protective coated for corrosion resistance.	
Race - 52100 steel, heat treated, protective coated for corrosion resistance.	
Ball - 52100 steel, heat treated, protective coated for corrosion resistance.	

K-Series -- Body Non Heat-Treated

Rod End No.		DIMENSIONS IN INCHES											a° Mis-align. Angle	Ultimate Radial Static Load Capacity Lbs.	Approx. Brg. Wt. Lbs.
Right Hand	Left Hand	B + .0000 - .0005	W + .000 - .005	H ± .020	A ± .040	D ± .030	K ± .045	J ± .030	F ± .030	Ball Dia. Ref.	C + .062 - .031	Thread UNF-2B			
1 KW-20-1	KG-20-1	1.2500	1.093	.937	4.125	2.750	1.625	1.500	.500	1.795	2.125	1 1/4-12	7.0	44,500	2.125
KW-24-1	KG-24-1	1.5000	1.312	1.125	5.375	3.500	2.250	2.000	.875	2.155	2.625	1 1/2-12	6.5	64,770	6.50
KW-32-1	KG-32-1	2.0000	1.750	1.500	8.000	5.000	3.125	2.750	2.062	2.875	4.000	2-12 ²	6.0	153,528	15.00

A-Series -- Body Heat-Treated

Rod End No.		DIMENSIONS IN INCHES											a° Mis-align. Angle	Ultimate Radial Static Load Capacity Lbs.	Approx. Brg. Wt. Lbs.
Right Hand	Left Hand	B + .0000 - .0005	W + .000 - .005	H ± .020	A ± .040	D ± .030	K ± .045	J ± .030	F ± .030	Ball Dia. Ref.	C + .062 - .031	Thread UNF-2B			
1 AW-20-1	AG-20-1	1.2500	1.093	.937	4.125	2.750	1.625	1.500	.500	1.795	2.125	1 1/4-12	7.0	79,728	2.125
AW-24-1	AG-24-1	1.5000	1.312	1.125	5.375	3.500	2.250	2.000	.875	2.155	2.625	1 1/2-12	6.5	138,826	6.50
AW-32-1	AG-32-1	2.0000	1.750	1.500	8.000	5.000	3.125	2.750	2.062	2.875	4.000	2-12 ²	6.0	378,955	15.00

1 Tolerance variation: "H" ± .005, "K" ± .015, "J" ± .015, "F" ± .015
 2 Threads 2-12 UN-2B

Units are supplied without grease fittings. When a grease fitting is required, specify by adding suffix as designated.

- Z Zerk type fitting Ex: KW-24Z-1
- F Flush type fitting Ex: KW-24F-1
- T PTFE liner Ex: KW-24T-1



Large Bore Series Male Rod Ends
General Purpose & High Strength - Precision - PTFE Lined

ROD ENDS

1 1/4", 1 1/2" & 2" sizes

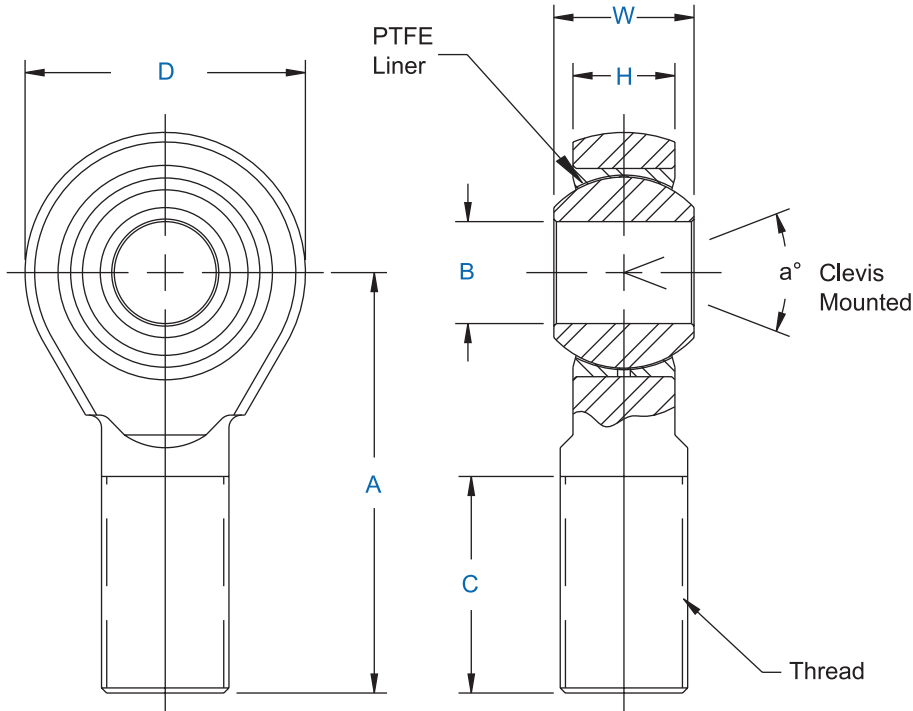

Specifications
Body (M-Series) - Alloy steel, protective coated for corrosion resistance.
Body (A-Series) - Alloy steel, heat treated, protective coated for corrosion resistance.
Race - Carbon steel, PTFE lined.
Ball - Alloy steel, heat treated, hard chrome plated.

M-Series -- Body Non Heat-Treated

Rod End No.		DIMENSIONS IN INCHES								a° Misalign. Angle	Ultimate Radial Static Load Capacity Lbs.	Approx. Brg. Wt. Lbs.
Right Hand	Left Hand	B + .0015 - .0005	W ± .005	H ± .020	A ± .040	D ± .030	Ball Dia. Ref.	C +.062 -.031	Thread UNF-3A			
MM-20T	MB-20T	1.2500	1.187	1.000	4.125	2.750	2.000	2.125	1 1/4-12	9.0	31,480	2.406
MM-24T	MB-24T	1.5000	1.375	1.125	5.375	3.500	2.312	3.000	1 1/2-12	8.75	66,264	4.75
MM-32T	MB-32T	2.0000	1.750	1.437	8.020	5.010	2.937	4.500	2-12 ¹	7.5	163,634	14.25

A-Series -- Body Heat-Treated

Rod End No.		DIMENSIONS IN INCHES								a° Misalign. Angle	Ultimate Radial Static Load Capacity Lbs.	Approx. Brg. Wt. Lbs.
Right Hand	Left Hand	B + .0015 - .0005	W ± .005	H ± .020	A ± .040	D ± .030	Ball Dia. Ref.	C +.062 -.031	Thread UNF-3A			
AM-20T	AB-20T	1.2500	1.187	1.000	4.125	2.750	2.000	2.125	1 1/4-12	9.0	65,047	2.406
AM-24T	AB-24T	1.5000	1.375	1.125	5.375	3.500	2.312	3.000	1 1/2-12	8.75	136,427	4.75
AM-32T	AB-32T	2.0000	1.750	1.437	8.020	5.010	2.937	4.500	2-12 ¹	7.5	280,740	14.25

¹Threads 2-12 UN-3A



Large Bore Series Female Rod Ends
 General Purpose & High Strength - Precision - PTFE Lined

ROD ENDS

1 1/4", 1 1/2" & 2" sizes

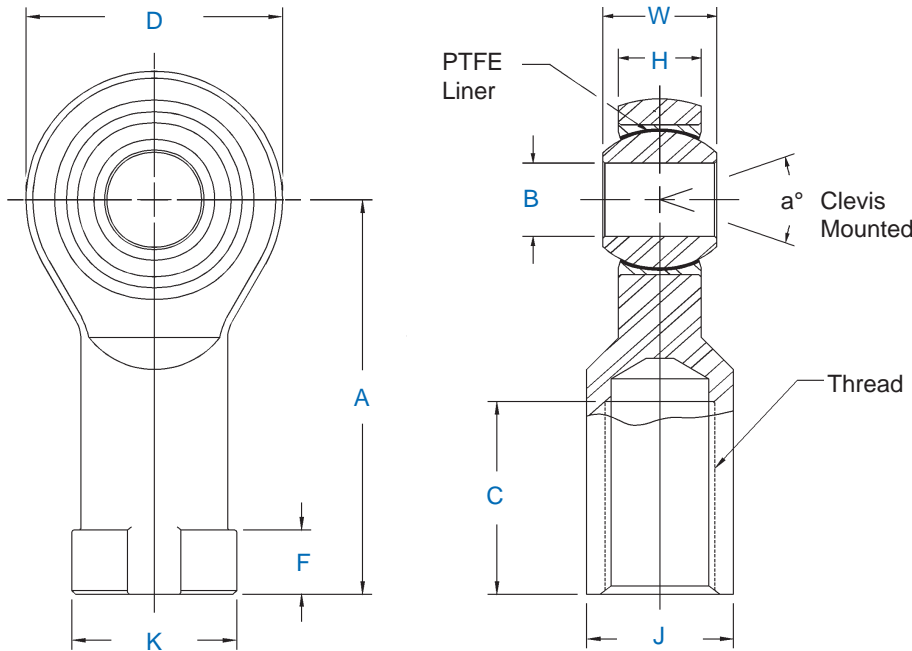

Specifications
Body (M-Series) - Alloy steel, protective coated for corrosion resistance.
Body (A-Series) - Alloy steel, heat treated, protective coated for corrosion resistance.
Race - Carbon steel, PTFE lined.
Ball - Alloy steel, heat treated, hard chrome plated.

M-Series -- Body Non Heat-Treated

Rod End No.		DIMENSIONS IN INCHES											a° Misalgn. Angle	Ultimate Radial Static Load Capacity Lbs.	Approx. Brg. Wt. Lbs.
Right Hand	Left Hand	B + .0015 - .0005	W ± .005	H ± .020	A ± .040	D ± .030	K ± .045	J ± .030	F ± .030	Ball Dia. Ref.	C + .062 - .031	Thread UNF-2B			
MW-20T	MG-20T	1.2500	1.187	1.000	4.125	2.750	1.625	1.500	.500	2.000	2.125	1 1/4-12	9.0	31,480	2.125
MW-24T	MG-24T	1.5000	1.375	1.125	5.375	3.500	2.250	2.000	.875	2.312	2.625	1 1/2-12	8.75	66,264	6.50
MW-32T	MG-32T	2.0000	1.750	1.437	8.020	5.010	3.155	2.750	2.062	2.937	4.000	2-12 ¹	7.5	163,634	15.00

A-Series -- Body Heat-Treated

Rod End No.		DIMENSIONS IN INCHES											a° Misalgn. Angle	Ultimate Radial Static Load Capacity Lbs.	Approx. Brg. Wt. Lbs.
Right Hand	Left Hand	B + .0015 - .0005	W ± .005	H ± .020	A ± .040	D ± .030	K ± .045	J ± .030	F ± .030	Ball Dia. Ref.	C + .062 - .031	Thread UNF-2B			
AW-20T	AG-20T	1.2500	1.187	1.000	4.125	2.750	1.625	1.500	.500	2.000	2.125	1 1/4-12	9.0	65,047	2.125
AW-24T	AG-24T	1.5000	1.375	1.125	5.375	3.500	2.250	2.000	.875	2.312	2.625	1 1/2-12	8.75	115,610	6.50
AW-32T	AG-32T	2.0000	1.750	1.437	8.020	5.010	3.155	2.750	2.062	2.937	4.000	2-12 ¹	7.5	280,740	15.00

¹Threads 2-12 UN-2B



CAM & CAB Series Male Rod Ends

High Strength - Economy Series

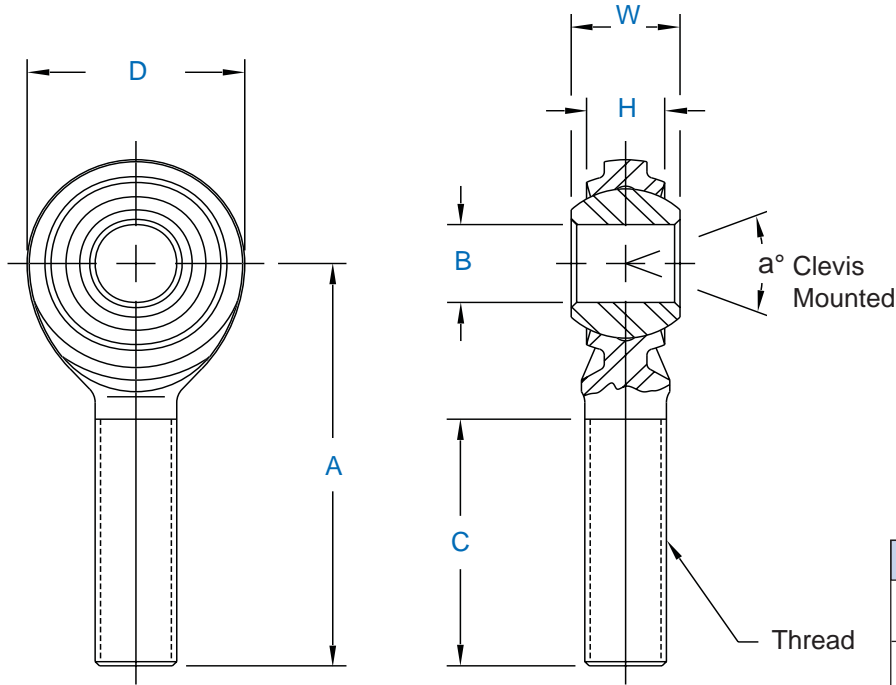

Specifications
Body - Alloy steel, heat treated, protective coated for corrosion resistance.
Ball - Alloy steel, heat treated, hard chrome plated.

Rod End No.		DIMENSIONS IN INCHES								a° Misalign. Angle	Ultimate Radial Static Load Capacity Lbs.	Approx. Brg. Wt. Lbs.
Right Hand	Left Hand	B + .0025 - .0005	W ± .005	H Ref.	A ± .015	D Ref.	Ball Dia. Ref.	C + .062 - .031	Thread UNF-3A			
CAM-5	CAB-5	.3125	.437	.312	1.875	.875	.625	1.250	5/16-24	22	6,684	.07
CAM-6	CAB-6	.3750	.500	.359	1.938	1.000	.719	1.250	3/8-24	22	9,088	.11
CAM-7	CAB-7	.4375	.562	.406	2.125	1.125	.812	1.375	7/16-20	21	11,445	.15
CAM-8	CAB-8	.5000	.625	.453	2.438	1.312	.937	1.500	1/2-20	20	15,479	.24
CAM-10	CAB-10	.6250	.750	.484	2.625	1.500	1.125	1.625	5/8-18	26	17,470	.36
CAM-12	CAB-12	.7500	.875	.593	2.875	1.750	1.312	1.750	3/4-16	24	24,471	.57

Rod End No.		DIMENSIONS IN MILLIMETERS								a° Misalign. Angle	Ultimate Radial Static Load Capacity Newtons	Approx. Brg. Wt. Grams
Right Hand	Left Hand	B + .064 - .013	W ± .13	H Ref.	A ± .38	D Ref.	Ball Dia. Ref.	C +1.57 - .79	Thread UNF-3A			
CAM-5	CAB-5	7.938	11.10	7.92	47.63	22.23	15.88	31.75	5/16-24	22	30,531	32
CAM-6	CAB-6	9.525	12.70	9.12	49.23	25.40	18.26	31.75	3/8-24	22	40,423	50
CAM-7	CAB-7	11.113	14.27	10.31	53.98	28.58	20.62	34.93	7/16-20	21	50,907	68
CAM-8	CAB-8	12.700	15.88	11.50	61.93	33.32	23.80	38.10	1/2-20	20	68,851	109
CAM-10	CAB-10	15.875	19.05	12.29	66.68	38.10	28.58	41.28	5/8-18	26	77,707	163
CAM-12	CAB-12	19.050	22.23	15.06	73.03	44.45	33.32	44.45	3/4-16	24	108,847	259



VCAM & VCAB Series Male Rod Ends
High Strength - Self Lubricating
Economy Series

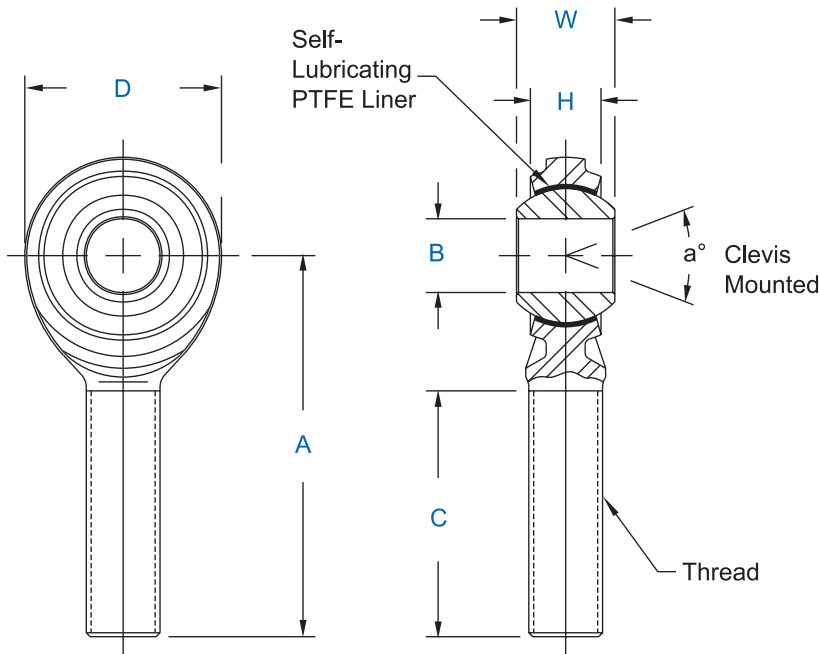

Specifications	
Body	- Alloy steel, heat treated, protective coated for corrosion resistance, PTFE lined.
Ball	- Alloy steel, heat treated, hard chrome plated.

Rod End No.		DIMENSIONS IN INCHES								a° Misalign. Angle	Ultimate Radial Static Load Capacity Lbs.	Approx. Brg. Wt. Lbs.
Right Hand	Left Hand	B + .0025 - .0005	W ± .005	H Ref.	A ± .015	D Ref.	Ball Dia. Ref.	C + .062 - .031	Thread UNF-3A			
VCAM-5	VCAB-5	.3125	.437	.312	1.875	.875	.593	1.250	5/16-24	22	5,032	.07
VCAM-6	VCAB-6	.3750	.500	.359	1.938	1.000	.687	1.250	3/8-24	22	6,533	.11
VCAM-7	VCAB-7	.4375	.562	.406	2.125	1.125	.781	1.375	7/16-20	21	8,054	.15
VCAM-8	VCAB-8	.5000	.625	.453	2.438	1.312	.875	1.500	1/2-20	20	13,425	.24
VCAM-10	VCAB-10	.6250	.750	.484	2.625	1.500	1.062	1.625	5/8-18	26	14,755	.36
VCAM-12	VCAB-12	.7500	.875	.593	2.875	1.750	1.250	1.750	3/4-16	24	21,150	.57

Rod End No.		DIMENSIONS IN MILLIMETERS								a° Misalign. Angle	Ultimate Radial Static Load Capacity Newtons	Approx. Brg. Wt. Grams
Right Hand	Left Hand	B + .064 - .013	W ± .13	H Ref.	A ± .38	D Ref.	Ball Dia. Ref.	C +1.57 - .79	Thread UNF-3A			
VCAM-5	VCAB-5	7.938	11.10	7.92	47.63	22.23	15.06	31.75	5/16-24	22	22,382	32
VCAM-6	VCAB-6	9.525	12.70	9.12	49.23	25.40	17.45	31.75	3/8-24	22	29,059	50
VCAM-7	VCAB-7	11.113	14.27	10.31	53.98	28.58	19.84	34.93	7/16-20	21	35,824	68
VCAM-8	VCAB-8	12.700	15.88	11.50	61.93	33.32	22.23	38.10	1/2-20	20	59,714	109
VCAM-10	VCAB-10	15.875	19.05	12.29	66.68	38.10	26.97	41.28	5/8-18	26	65,630	163
VCAM-12	VCAB-12	19.050	22.23	15.06	73.03	44.45	31.75	44.45	3/4-16	24	94,075	259



AM & AB Series Male Rod Ends
High Strength Alloy - Precision (PTFE Liners Available)

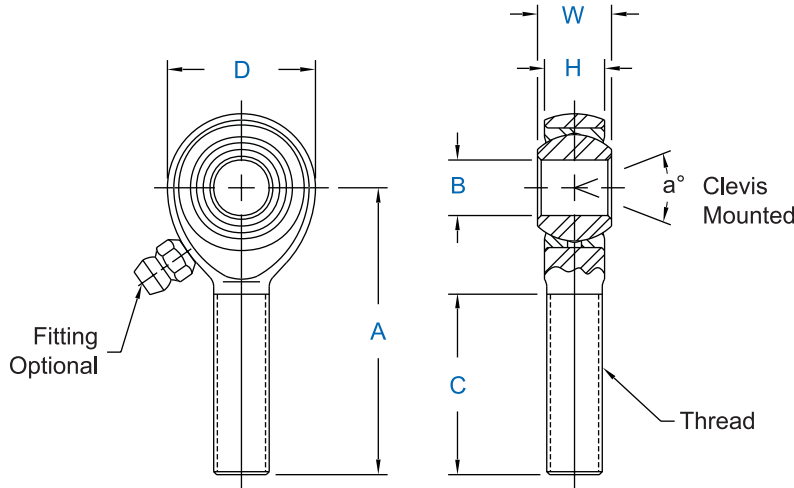

Specifications	
Body	- Alloy Steel, heat treated, protective coated for corrosion resistance.
Race	- Alloy steel, heat treated, protective coated for corrosion resistance (Carbon steel with PTFE liners).
Ball	- Alloy steel, heat treated, hard chrome plated.
Notes	
Units in this series will be magnafluxed on special request only.	

Rod End No.		DIMENSIONS IN INCHES								a° Misalign. Angle	Ultimate Radial Static Load Capacity Lbs.	Approx. Brg. Wt. Lbs.
Right Hand	Left Hand	B + .0015 - .0005	W + .000 - .005	H ± .005	A ± .010	D ± .010	Ball Dia. Ref.	C + .062 - .031	Thread UNF-3A			
AM-3	AB-3	.1900	.312	.250	1.250	.625	.437	.750	10-32	13	2,851	.028
AM-4	AB-4	.2500	.375	.281	1.562	.750	.500	1.000	1/4-28	16	5,260	.043
AM-5	AB-5	.3125	.437	.344	1.875	.875	.625	1.250	5/16-24	14	7,639	.072
AM-6	AB-6	.3750	.500	.406	1.938	1.000	.719	1.250	3/8-24	12	9,544	.112
AM-7	AB-7	.4375	.562	.437	2.125	1.125	.812	1.375	7/16-20	14	10,285	.160
AM-8	AB-8	.5000	.625	.500	2.438	1.312	.937	1.500	1/2-20	12	16,238	.249
AM-10	AB-10	.6250	.750	.562	2.625	1.500	1.125	1.625	5/8-18	16	17,955	.382
AM-12	AB-12	.7500	.875	.687	2.875	1.750	1.312	1.750	3/4-16	14	28,081	.602
AM-12-20	AB-12-20	.7500	.875	.687	2.875	1.750	1.312	1.750	7/8-14	14	28,081	.720
AM-14	AB-14	.8750	.875	.765	3.375	2.000	1.375	2.000	7/8-14	7	45,051	.906
* AM-14-1	AB-14-1	.8750	.875	.687	3.375	2.000	1.312	1.875	7/8-14	12	55,692	.906
1 AM-16	AB-16	1.0000	1.375	1.000	4.125	2.750	1.875	2.125	1 1/4-12	17	76,200	2.406
1 AM-16-1	AB-16-1	1.0000	1.375	1.000	4.125	2.750	1.875	2.125	1-14 ³	17	76,200	2.127
1 AM-16-2	AB-16-2	1.0000	1.375	1.000	4.125	2.750	1.875	2.125	1-12	17	76,200	2.127

Rod End No.		DIMENSIONS IN MILLIMETERS								a° Misalign. Angle	Ultimate Radial Static Load Capacity Newtons	Approx. Brg. Wt. Grams
Right Hand	Left Hand	B + .038 - .013	W + .00 - .13	H ± .13	A ± .25	D ± .25	Ball Dia. Ref.	C + 1.57 - .79	Thread UNF-3A			
AM-3	AB-3	4.826	7.92	6.35	31.75	15.88	11.10	19.05	10-32	13	12,679	13
AM-4	AB-4	6.350	9.53	7.14	39.67	19.05	12.70	25.40	1/4-28	16	23,397	20
AM-5	AB-5	7.938	11.10	8.74	47.63	22.23	15.88	31.75	5/16-24	14	33,978	33
AM-6	AB-6	9.525	12.70	10.31	49.23	25.40	18.26	31.75	3/8-24	12	42,450	51
AM-7	AB-7	11.113	14.27	11.10	53.98	28.58	20.62	34.93	7/16-20	14	45,745	73
AM-8	AB-8	12.700	15.88	12.70	61.93	33.32	23.80	38.10	1/2-20	12	72,231	113
AM-10	AB-10	15.875	19.05	14.27	66.68	38.10	28.58	41.28	5/8-18	16	79,861	173
AM-12	AB-12	19.050	22.23	17.45	73.03	44.45	33.32	44.45	3/4-16	14	124,910	273
AM-12-20	AB-12-20	19.050	22.23	17.45	73.03	44.45	33.32	44.45	7/8-14	14	124,910	273
AM-14	AB-14	22.225	22.23	19.43	85.73	50.80	34.93	50.80	7/8-14	7	200,387	411
* AM-14-1	AB-14-1	22.225	22.23	17.45	85.73	50.80	33.32	47.63	7/8-14	12	247,718	411
2 AM-16	AB-16	25.400	34.93	25.40	104.78	69.85	47.63	53.98	1 1/4-12	17	338,937	1,091
2 AM-16-1	AB-16-1	25.400	34.93	25.40	104.78	69.85	47.63	53.98	1-14 ³	17	338,937	965
2 AM-16-2	AB-16-2	25.400	34.93	25.40	104.78	69.85	47.63	53.98	1-12	17	338,937	965

* Check for availability.

1 Tolerance variation: "D" ± .020, "A" ± .020, "B" + .0035, - .0005, "H" ± .010 Check for availability.

2 Tolerance variation: "D" ± .51, "A" ± .51, "B" + .089, - .013, "H" ± .25 Check for availability.

3 Threads 1-14 UNS.

Units are supplied without grease fittings. When a grease fitting is required, specify by adding suffix as designated.

Z Zerk type fitting

Ex: AM-6Z

F Flush type fitting

Ex: AM-6F

T PTFE liner

Ex: AM-6T

Load ratings apply only to rod ends without grease fittings. For load ratings with fittings, please consult our engineering department.



AW & AG Series Female Rod Ends

High Strength Alloy - Precision (PTFE Liners Available)

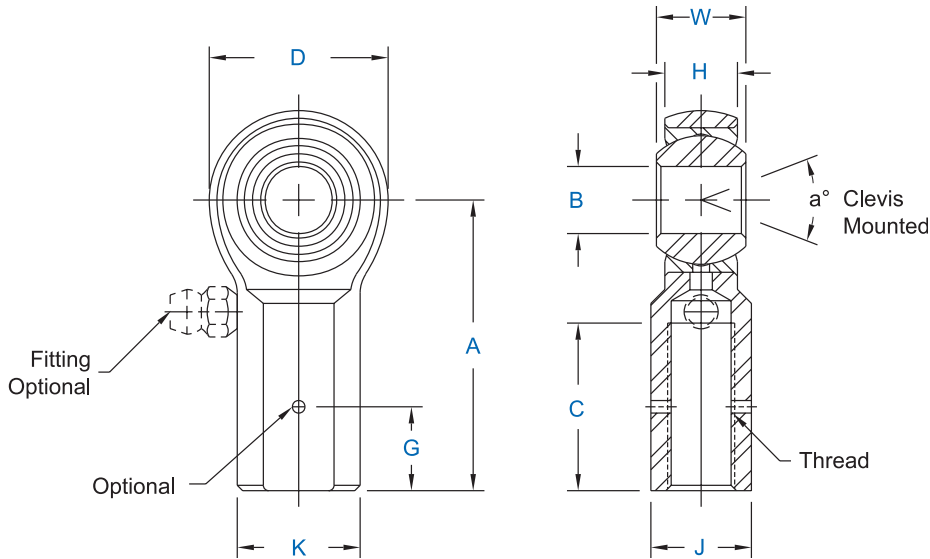

Specifications
Body - Alloy Steel, heat treated, protective coated for corrosion resistance.
Race - Alloy steel, heat treated, protective coated for corrosion resistance (Carbon steel with PTFE liners).
Ball - Alloy steel, heat treated, hard chrome plated.
Notes
Units in this series will be magnafluxed on special request only.

Rod End No.		DIMENSIONS IN INCHES											a° Mis-align. Angle	Ultimate Radial Static Load Capacity Lbs.	Approx. Brg. Wt. Lbs.
Right Hand	Left Hand	B + .0015 - .0005	W + .000 - .0005	H ± .005	A ± .010	D ± .010	K ± .010	J ± .010	G ± .010	Ball Dia. Ref.	C + .062 - .031	Thread UNF-3B			
AW-3	AG-3	.1900	.312	.250	1.062	.625	.406	.312	.312	.437	.562	10-32	13	3,733	.038
AW-4	AG-4	.2500	.375	.281	1.312	.750	.469	.375	.312	.500	.750	1/4-28	16	6,190	.059
AW-5	AG-5	.3125	.437	.344	1.375	.875	.500	.437	.406	.625	.750	5/16-24	14	7,639	.092
AW-6	AG-6	.3750	.500	.406	1.625	1.000	.687	.562	.469	.719	.937	3/8-24	12	9,544	.152
AW-7	AG-7	.4375	.562	.437	1.812	1.125	.750	.625	.531	.812	1.062	7/16-20	14	10,285	.198
AW-8	AG-8	.5000	.625	.500	2.125	1.312	.875	.750	.594	.937	1.187	1/2-20	12	16,238	.329
AW-10	AG-10	.6250	.750	.562	2.500	1.500	1.000	.875	.750	1.125	1.500	5/8-18	16	17,955	.477
AW-12	AG-12	.7500	.875	.687	2.875	1.750	1.125	1.000	.875	1.312	1.750	3/4-16	14	28,081	.723
* AW-14	AG-14	.8750	.875	.765	3.375	2.000	1.300	1.125	.937	1.375	1.875	7/8-14	7	45,051	1.030
1 AW-16	AG-16	1.0000	1.375	1.000	4.125	2.750	1.625	1.500	1.250	1.875	2.125	1 1/4-12	17	76,200	2.125
1 AW-16-1	AG-16-1	1.0000	1.375	1.000	4.125	2.750	1.625	1.500	1.250	1.875	2.125	1-14 ³	17	76,200	2.410
1 AW-16-2	AG-16-2	1.0000	1.375	1.000	4.125	2.750	1.625	1.500	1.250	1.875	2.125	1-12	17	76,200	2.410

Rod End No.		DIMENSIONS IN MILLIMETERS											a° Mis-align. Angle	Ultimate Radial Static Load Capacity Newtons	Approx. Brg. Wt. Grams
Right Hand	Left Hand	B + .038 - .013	W + .00 - .13	H ± .13	A ± .25	D ± .25	K ± .25	J ± .25	G ± .25	Ball Dia. Ref.	C +1.57 - .79	Thread UNF-3B			
AW-3	AG-3	4.826	7.92	6.35	26.97	15.88	10.31	7.92	7.92	11.10	14.27	10-32	13	16,602	17
AW-4	AG-4	6.350	9.53	7.14	33.32	19.05	11.91	9.53	7.92	12.70	19.05	1/4-28	16	27,535	27
AW-5	AG-5	7.938	11.10	8.74	34.93	22.23	12.70	11.10	10.31	15.88	19.05	5/16-24	14	33,978	42
AW-6	AG-6	9.525	12.70	10.31	41.28	25.40	17.45	14.27	11.91	18.26	23.80	3/8-24	12	42,450	69
AW-7	AG-7	11.113	14.27	11.10	46.02	28.58	19.05	15.88	13.49	20.62	26.97	7/16-20	14	45,745	90
AW-8	AG-8	12.700	15.88	12.70	53.98	33.32	22.23	19.05	15.09	23.80	30.15	1/2-20	12	72,231	149
AW-10	AG-10	15.875	19.05	14.27	63.50	38.10	25.40	22.23	19.05	28.58	38.10	5/8-18	16	79,861	216
AW-12	AG-12	19.050	22.23	17.45	73.03	44.45	28.58	25.40	22.23	33.32	44.45	3/4-16	14	124,910	328
* AW-14	AG-14	22.225	22.23	19.43	85.73	50.80	33.02	28.58	23.80	34.93	47.63	7/8-14	7	200,387	467
2 AW-16	AG-16	25.400	34.93	25.40	104.78	69.85	41.28	38.10	31.75	47.63	53.98	1 1/4-12	17	338,937	964
2 AW-16-1	AG-16-1	25.400	34.93	25.40	104.78	69.85	41.28	38.10	31.75	47.63	53.98	1-14 ³	17	338,937	1,093
2 AW-16-2	AG-16-2	25.400	34.93	25.40	104.78	69.85	41.28	38.10	31.75	47.63	53.98	1-12	17	338,937	1,093

* Check for availability.

1 Tolerance variation: "D" ± .020, "A" ± .020 "B" + .0035, - .0005, "H" ± .010, "K" ± .015, "J" ± .015 Check for availability.

2 Tolerance variation: "D" ± .51, "A" ± .51 "B" + .089, - .013, "H" ± .25, "K" ± .38, "J" ± .38 Check for availability.

3 Threads 1-14 UNS

4 Above notes 1 and 2 have 2B threads

Units are supplied without grease fittings. When a grease fitting is required, specify by adding suffix as designated.

Z Zerk type fitting
F Flush type fitting
T PTFE liner

Ex: AW-6Z
Ex: AW-6F
Ex: AW-6T



**CM-ET & CB-ET Series Stainless Steel
Male Rod Ends (PTFE) Lined**
Corrosion Resistant - Precision - Self-Lubricating

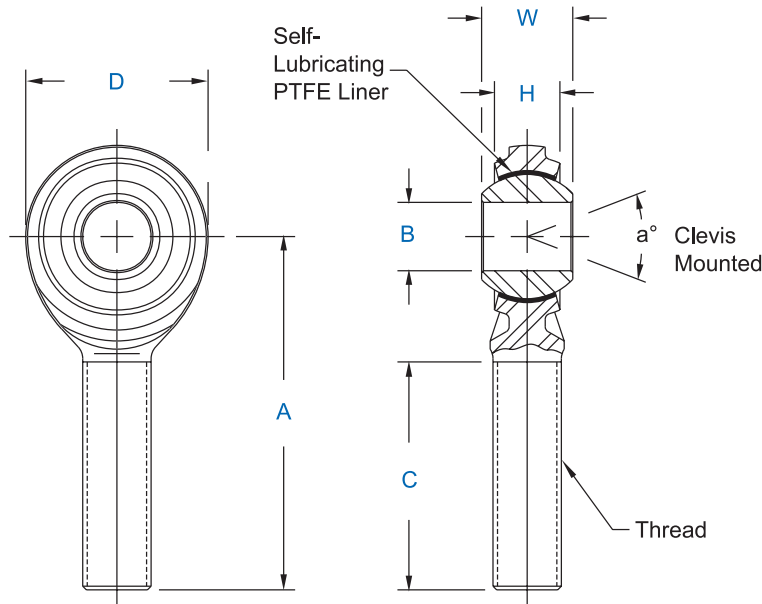

Specifications	
Body - 17-4 PH stainless steel (AMS 5342), PTFE lined.	
Ball - 440 C stainless steel (AMS 5630), heat treated, hard chrome plated.	

Rod End No.		DIMENSIONS IN INCHES								a° Misalign. Angle	Ultimate Radial Static Load Capacity Lbs.	Approx. Brg. Wt. Lbs.
Right Hand	Left Hand	B + .0015 - .0005	W + .000 - .005	H Ref.	A ± .015	D Ref.	Ball Dia. Ref.	C + .062 - .031	Thread UNF-3A			
CM-5ET	CB-5ET	.3125	.437	.312	1.875	.875	.593	1.250	5/16-24	22	6,451	.07
CM-6ET	CB-6ET	.3750	.500	.359	1.938	1.000	.687	1.250	3/8-24	22	8,627	.11
CM-7ET	CB-7ET	.4375	.562	.406	2.125	1.125	.781	1.375	7/16-20	21	9,370	.15
CM-8ET	CB-8ET	.5000	.625	.453	2.438	1.312	.875	1.500	1/2-20	20	15,130	.24
CM-10ET	CB-10ET	.6250	.750	.484	2.625	1.500	1.062	1.625	5/8-18	26	16,922	.36
CM-12ET	CB-12ET	.7500	.875	.593	2.875	1.750	1.250	1.750	3/4-16	24	25,549	.57

Rod End No.		DIMENSIONS IN MILLIMETERS								a° Misalign. Angle	Ultimate Radial Static Load Capacity Newtons	Approx. Brg. Wt. Grams
Right Hand	Left Hand	B + .038 - .013	W + .00 - .13	H Ref.	A ± .38	D Ref.	Ball Dia. Ref.	C +1.57 - .79	Thread UNF-3A			
CM-5ET	CB-5ET	7.938	11.10	7.92	47.63	22.23	15.06	31.75	5/16-24	22	28,693	32
CM-6ET	CB-6ET	9.525	12.70	9.12	49.23	25.40	17.45	31.75	3/8-24	22	38,371	50
CM-7ET	CB-7ET	11.113	14.27	10.31	53.98	28.58	19.84	34.93	7/16-20	21	41,676	68
CM-8ET	CB-8ET	12.700	15.88	11.50	61.93	33.32	22.23	38.10	1/2-20	20	67,299	109
CM-10ET	CB-10ET	15.875	19.05	12.29	66.68	38.10	26.97	41.28	5/8-18	26	75,271	163
CM-12ET	CB-12ET	19.050	22.23	15.06	73.03	44.45	31.75	44.45	3/4-16	24	113,642	259



**CW-ET & CG-ET Series Stainless Steel
Female Rod Ends (PTFE) Lined**
Corrosion Resistant - Precision - Self-Lubricating

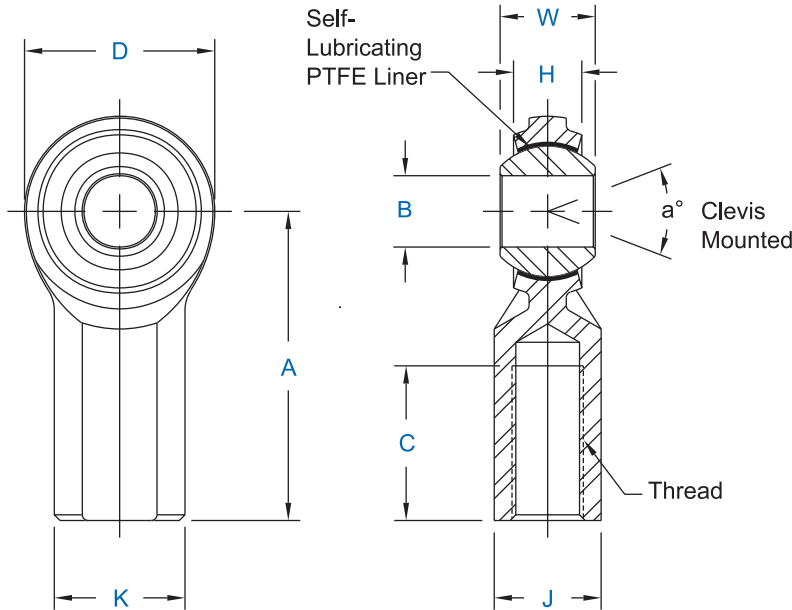

Specifications	
Body - 17-4 PH stainless steel (AMS 5342), PTFE lined.	
Ball - 440 C stainless steel (AMS 5630), heat treated, hard chrome plated.	

Rod End No.		DIMENSIONS IN INCHES										a° Misalign. Angle	Ultimate Radial Static Load Capacity Lbs.	Approx. Brg. Wt. Lbs.
Right Hand	Left Hand	B + .0015 - .0005	W + .000 - .005	H Ref.	A ± .015	D Ref.	K ± .010	J ± .010	Ball Dia. Ref.	C + .062 - .031	Thread UNF-2B			
CW-5ET	CG-5ET	.3125	.437	.312	1.375	.875	.500	.437	.593	.687	5/16-24	22	6,451	.08
CW-6ET	CG-6ET	.3750	.500	.359	1.625	1.000	.687	.562	.687	.812	3/8-24	22	8,627	.13
CW-7ET	CG-7ET	.4375	.562	.406	1.812	1.125	.750	.625	.781	.937	7/16-20	21	9,370	.18
CW-8ET	CG-8ET	.5000	.625	.453	2.125	1.312	.875	.750	.875	1.062	1/2-20	20	15,130	.29
CW-10ET	CG-10ET	.6250	.750	.484	2.500	1.500	1.000	.875	1.062	1.375	5/8-18	26	16,922	.43
CW-12ET	CG-12ET	.7500	.875	.593	2.875	1.750	1.125	1.000	1.250	1.562	3/4-16	24	25,549	.65

Rod End No.		DIMENSIONS IN MILLIMETERS										a° Misalign. Angle	Ultimate Radial Static Load Capacity Newtons	Approx. Brg. Wt. Grams
Right Hand	Left Hand	B + .038 - .013	W + .00 - .13	H Ref.	A ± .38	D Ref.	K ± .25	J ± .25	Ball Dia. Ref.	C +1.57 - .79	Thread UNF-2B			
CW-5ET	CG-5ET	7.938	11.10	7.92	34.93	22.23	12.70	11.10	15.06	17.45	5/16-24	22	28,693	36
CW-6ET	CG-6ET	9.525	12.70	9.12	41.28	25.40	17.45	14.27	17.45	20.62	3/8-24	22	38,371	59
CW-7ET	CG-7ET	11.113	14.27	10.31	46.02	28.58	19.05	15.88	19.84	23.80	7/16-20	21	41,676	82
CW-8ET	CG-8ET	12.700	15.88	11.50	53.98	33.32	22.23	19.05	22.23	26.97	1/2-20	20	67,299	132
CW-10ET	CG-10ET	15.875	19.05	12.29	63.50	38.10	25.40	22.23	26.97	34.93	5/8-18	26	75,271	195
CW-12ET	CG-12ET	19.050	22.23	15.06	73.03	44.45	28.58	25.40	31.75	39.67	3/4-16	24	113,642	295



SM & SB Series Male Rod Ends
Corrosion Resistant - PTFE Liners Available

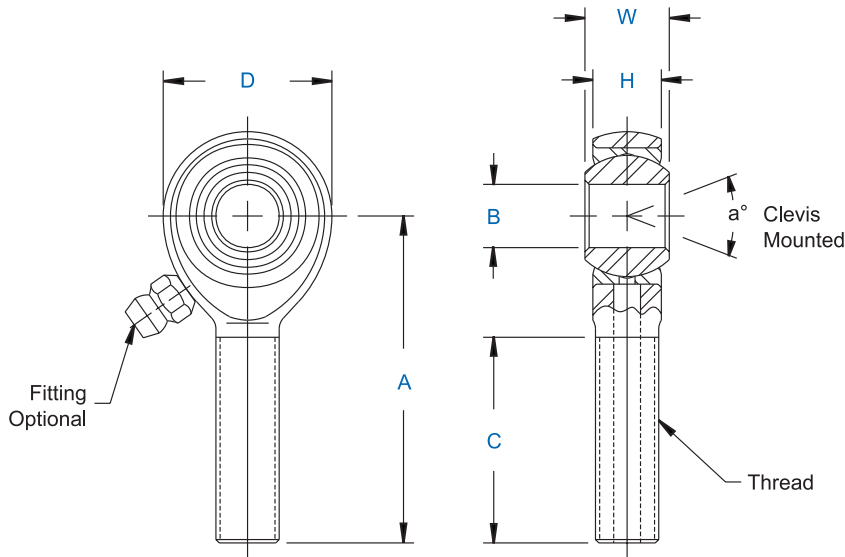

Specifications
Body - Carbon steel, Electroless nickel plated.
Race - Stainless steel, heat treated.
Ball - Alloy steel, heat treated, hard chrome plated.
Notes
Drilled hole in shank not available in 3, 4, and 5 bore sizes. All sizes available with studs upon request.

Rod End No.		DIMENSIONS IN INCHES								a° Misalign. Angle	Ultimate Radial Static Load Capacity Lbs.	Approx. Brg. Wt. Lbs.
Right Hand	Left Hand	B + .0015 - .0005	W + .000 - .005	H ± .005	A ± .015	D ± .010	Ball Dia. Ref.	C + .062 - .031	Thread UNF-3A			
SM-3	SB-3	.1900	.312	.250	1.250	.625	.437	.750	10-32	13	1,169	.028
SM-4	SB-4	.2500	.375	.281	1.562	.750	.500	1.000	1/4-28	16	2,158	.043
SM-5	SB-5	.3125	.437	.344	1.875	.875	.625	1.250	5/16-24	14	2,784	.072
SM-6	SB-6	.3750	.500	.406	1.938	1.000	.719	1.250	3/8-24	12	3,915	.112
SM-7	SB-7	.4375	.562	.437	2.125	1.125	.812	1.375	7/16-20	14	4,218	.160
SM-8	SB-8	.5000	.625	.500	2.438	1.312	.937	1.500	1/2-20	12	6,660	.249
SM-10	SB-10	.6250	.750	.562	2.625	1.500	1.125	1.625	5/8-18	16	7,364	.382
SM-12	SB-12	.7500	.875	.687	2.875	1.750	1.312	1.750	3/4-16	14	11,518	.602

Rod End No.		DIMENSIONS IN MILLIMETERS								a° Misalign. Angle	Ultimate Radial Static Load Capacity Newtons	Approx. Brg. Wt. Grams
Right Hand	Left Hand	B + .038 - .013	W + .00 - .13	H ± .13	A ± .38	D ± .25	Ball Dia. Ref.	C + 1.57 - .79	Thread UNF-3A			
SM-3	SB-3	4.826	7.92	6.35	31.75	15.88	11.10	19.05	10-32	13	5,197	13
SM-4	SB-4	6.350	9.53	7.14	39.67	19.05	12.70	25.40	1/4-28	16	9,600	20
SM-5	SB-5	7.938	11.10	8.74	47.63	22.23	15.88	31.75	5/16-24	14	12,385	33
SM-6	SB-6	9.525	12.70	10.31	49.23	25.40	18.26	31.75	3/8-24	12	17,416	51
SM-7	SB-7	11.113	14.27	11.10	53.98	28.58	20.62	34.93	7/16-20	14	18,759	73
SM-8	SB-8	12.700	15.88	12.70	61.93	33.32	23.80	38.10	1/2-20	12	29,624	113
SM-10	SB-10	15.875	19.05	14.27	66.68	38.10	28.58	41.28	5/8-18	16	32,752	173
SM-12	SB-12	19.050	22.23	17.45	73.03	44.45	33.32	44.45	3/4-16	14	51,237	273

Load ratings apply only to rod ends without grease fittings. For load ratings with fittings, please consult our engineering department.
Solid shank add suffix "Y". Ex: SM - 6Y

Units are supplied without grease fittings. When a grease fitting is required, specify by adding suffix as designated.
Z Zerk type fitting Ex: SM-6Z
F Flush type fitting Ex: SM-6F
T PTFE liner Ex: SM-6T



SW & SG Series Female Rod Ends

Corrosion Resistant - PTFE Liners Available

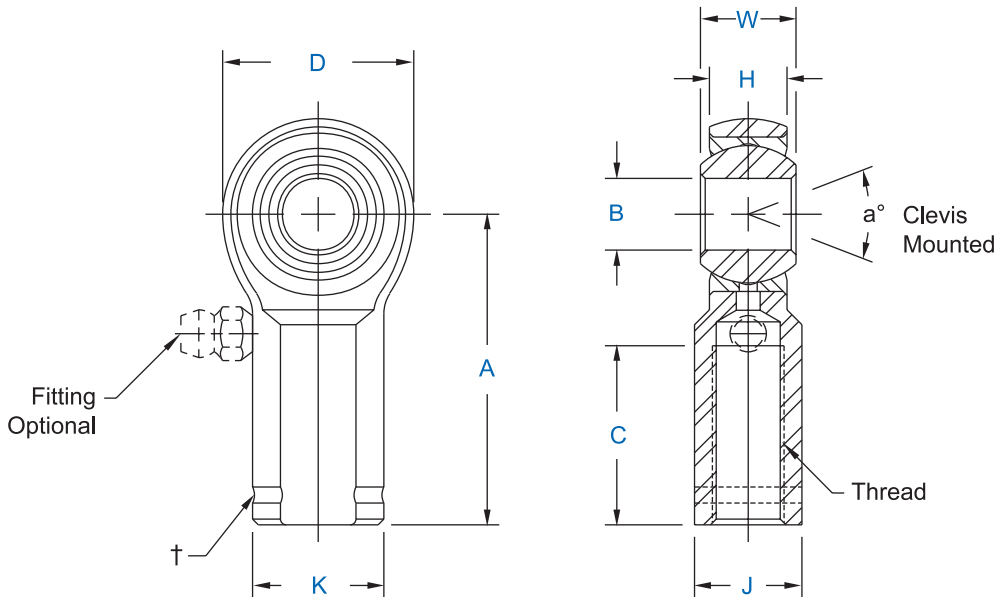

Specifications			
Body	Carbon steel, Electroless nickel plated.		
Race	Stainless steel, heat treated.		
Ball	Alloy steel, heat treated, hard chrome plated.		
Notes			
All sizes available with studs upon request.			

Rod End No.		DIMENSIONS IN INCHES										a° Misalign. Angle	Ultimate Radial Static Load Capacity Lbs.	Approx. Brg. Wt. Lbs.
Right Hand	Left Hand†	B +.0015 -.0005	W +.000 -.0005	H ± .005	A ± .015	D ± .010	K ± .010	J ± .010	Ball Dia. Ref.	C +.062 -.031	Thread UNF-2B			
SW-3	SG-3	.1900	.312	.250	1.062	.625	.406	.312	.437	.562	10-32	13	1,531	.038
SW-4	SG-4	.2500	.375	.281	1.312	.750	.469	.375	.500	.750	1/4-28	16	2,539	.059
SW-5	SG-5	.3125	.437	.344	1.375	.875	.500	.437	.625	.750	5/16-24	14	3,133	.092
SW-6	SG-6	.3750	.500	.406	1.625	1.000	.687	.562	.719	.937	3/8-24	12	3,915	.152
SW-7	SG-7	.4375	.562	.437	1.812	1.125	.750	.625	.812	1.062	7/16-20	14	4,218	.198
SW-8	SG-8	.5000	.625	.500	2.125	1.312	.875	.750	.937	1.187	1/2-20	12	6,660	.329
SW-10	SG-10	.6250	.750	.562	2.500	1.500	1.000	.875	1.125	1.500	5/8-18	16	7,364	.477
SW-12	SG-12	.7500	.875	.687	2.875	1.750	1.125	1.000	1.312	1.750	3/4-16	14	11,518	.723

Rod End No.		DIMENSIONS IN MILLIMETERS										a° Misalign. Angle	Ultimate Radial Static Load Capacity Newtons	Approx. Brg. Wt. Grams
Right Hand	Left Hand†	B +.038 -.013	W +.00 -.13	H ± .13	A ± .38	D ± .25	K ± .25	J ± .25	Ball Dia. Ref.	C +1.57 -.79	Thread UNF-2B			
SW-3	SG-3	4.826	7.92	6.35	26.97	15.88	10.31	7.92	11.10	14.27	10-32	13	6,805	17
SW-4	SG-4	6.350	9.53	7.14	33.32	19.05	11.91	9.53	12.70	19.05	1/4-28	16	11,297	27
SW-5	SG-5	7.938	11.10	8.74	34.93	22.23	12.70	11.10	15.88	19.05	5/16-24	14	13,934	42
SW-6	SG-6	9.525	12.70	10.31	41.28	25.40	17.45	14.27	18.26	23.80	3/8-24	12	17,416	69
SW-7	SG-7	11.113	14.27	11.10	46.02	28.58	19.05	15.88	20.62	26.97	7/16-20	14	18,759	90
SW-8	SG-8	12.700	15.88	12.70	53.98	33.32	22.23	19.05	23.80	30.15	1/2-20	12	29,624	149
SW-10	SG-10	15.875	19.05	14.27	63.50	38.10	25.40	22.23	28.58	38.10	5/8-18	16	32,752	216
SW-12	SG-12	19.050	22.23	17.45	73.03	44.45	28.58	25.40	33.32	44.45	3/4-16	14	51,237	328

† Left hand units have identification groove near end of shank.

Units are supplied without grease fittings. When a grease fitting is required, specify by adding suffix as designated.

- Z Zerk type fitting Ex: SW-6Z
- F Flush type fitting Ex: SW-6F
- T PTFE liner Ex: SW-6T



SM-E & SB-E Series Stainless Steel Male Rod Ends

Corrosion Resistant - Precision - PTFE Liners Available

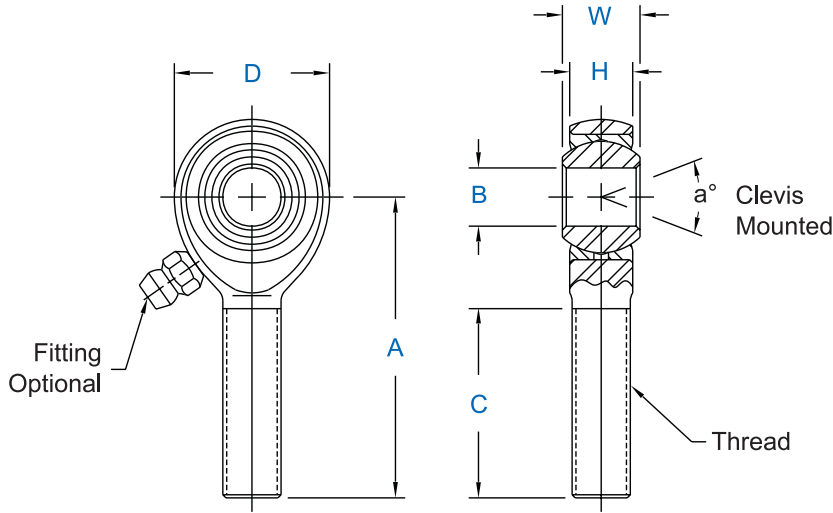

Specifications	
Body	17-4 PH stainless steel (AMS 5643), heat treated.
Race	17-4 PH stainless steel (AMS 5643), heat treated.
Ball	440 C stainless steel (AMS 5630), heat treated, hard chrome plated.

Rod End No.		DIMENSIONS IN INCHES								a° Misalign. Angle	Ultimate Radial Static Load Capacity Lbs.	Approx. Brg. Wt. Lbs.
Right Hand	Left Hand	B + .0015 - .0005	W + .000 - .005	H ± .005	A ± .015	D ± .010	Ball Dia. Ref.	C + .062 - .031	Thread UNF-3A			
SM-3E	SB-3E	.1900	.312	.250	1.250	.625	.437	.750	10-32	13	2,199	.028
SM-4E	SB-4E	.2500	.375	.281	1.562	.750	.500	1.000	1/4-28	16	4,058	.043
SM-5E	SB-5E	.3125	.437	.344	1.875	.875	.625	1.250	5/16-24	14	5,929	.072
SM-6E	SB-6E	.3750	.500	.406	1.938	1.000	.719	1.250	3/8-24	12	7,363	.112
SM-7E	SB-7E	.4375	.562	.437	2.125	1.125	.812	1.375	7/16-20	14	7,934	.160
SM-8E	SB-8E	.5000	.625	.500	2.438	1.312	.937	1.500	1/2-20	12	12,527	.249
SM-10E	SB-10E	.6250	.750	.562	2.625	1.500	1.125	1.625	5/8-18	16	13,851	.382
SM-12E	SB-12E	.7500	.875	.687	2.875	1.750	1.312	1.750	3/4-16	14	21,664	.602
SM-16E	SB-16E	1.000	1.375	1.000	4.125	2.750	1.875	2.125	1 1/4-12	14	72,947	2.406

Rod End No.		DIMENSIONS IN MILLIMETERS								a° Misalign. Angle	Ultimate Radial Static Load Capacity Newtons	Approx. Brg. Wt. Grams
Right Hand	Left Hand	B + .038 - .013	W + .00 - .13	H ± .13	A ± .38	D ± .25	Ball Dia. Ref.	C + 1.57 - .79	Thread UNF-3A			
SM-3E	SB-3E	4.826	7.92	6.35	31.75	15.88	11.10	19.05	10-32	13	9,781	13
SM-4E	SB-4E	6.350	9.53	7.14	39.67	19.05	12.70	25.40	1/4-28	16	18,050	20
SM-5E	SB-5E	7.938	11.10	8.74	47.63	22.23	15.88	31.75	5/16-24	14	26,372	33
SM-6E	SB-6E	9.525	12.70	10.31	49.23	25.40	18.26	31.75	3/8-24	12	32,751	51
SM-7E	SB-7E	11.113	14.27	11.10	53.98	28.58	20.62	34.93	7/16-20	14	35,290	73
SM-8E	SB-8E	12.700	15.88	12.70	61.93	33.32	23.80	38.10	1/2-20	12	55,720	113
SM-10E	SB-10E	15.875	19.05	14.27	66.68	38.10	28.58	41.28	5/8-18	16	61,609	173
SM-12E	SB-12E	19.050	22.23	17.45	73.03	44.45	33.32	44.45	3/4-16	14	96,361	273
SM-16E	SB-16E	25.400	34.93	25.40	104.78	69.85	47.63	53.98	1 1/4-12	14	324,468	1,091

1 Tolerance variation: "D" ± .020, "A" ± .020, "B" + .0035, - .0005, "H" ± .010
 2 Tolerance variation: "D" ± .51, "A" ± .51, "B" + .089, - .013, "H" ± .25

Units are supplied without grease fittings. When a grease fitting is required, specify by adding suffix as designated.
 Z Zerk type fitting Ex: SM-6EZ
 F Flush type fitting Ex: SM-6EF
 T PTFE liner Ex: SM-6ET
 Load ratings apply only to rod ends without grease fittings. For load ratings with fittings, please consult our engineering department.



SW-E & SG-E Series Stainless Steel Female Rod Ends

Corrosion Resistant - Precision - PTFE Liners Available

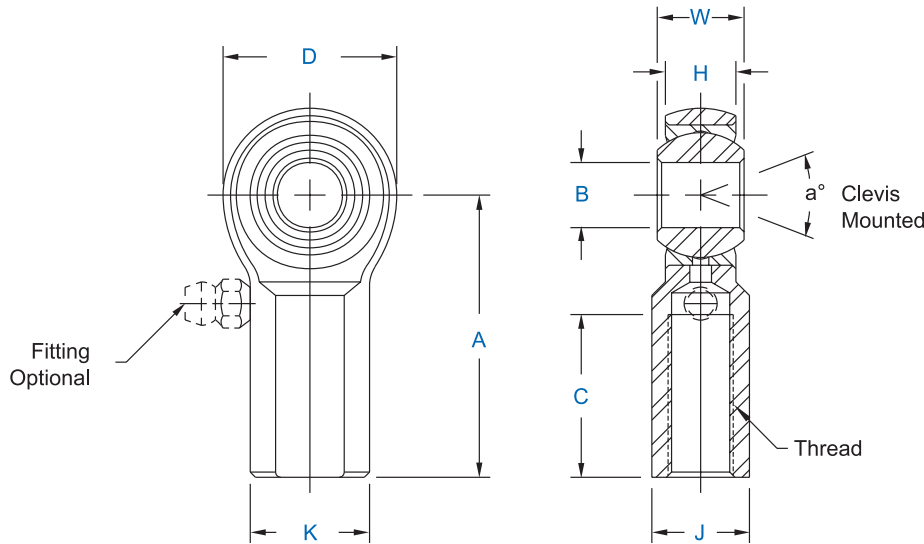

Specifications	
Body	17-4 PH stainless steel (AMS 5643), heat treated.
Race	17-4 PH stainless steel (AMS 5643), heat treated.
Ball	440 C stainless steel (AMS 5630), heat treated, hard chrome plated.

Rod End No.		DIMENSIONS IN INCHES										a° Misalgn. Angle	Ultimate Radial Static Load Capacity Lbs.	Approx. Brg. Wt. Lbs.
Right Hand	Left Hand	B + .0015 - .0005	W + .000 - .005	H ± .005	A ± .015	D ± .010	K ± .010	J ± .010	Ball Dia. Ref.	C + .062 - .031	Thread UNF-3B			
SW-3E	SG-3E	.1900	.312	.250	1.062	.625	.406	.312	.437	.562	10-32	13	2,895	.038
SW-4E	SG-4E	.2500	.375	.281	1.312	.750	.469	.375	.500	.750	1/4-28	16	4,795	.059
SW-5E	SG-5E	.3125	.437	.344	1.375	.875	.500	.437	.625	.750	5/16-24	14	5,929	.092
SW-6E	SG-6E	.3750	.500	.406	1.625	1.000	.687	.562	.719	.937	3/8-24	12	7,363	.152
SW-7E	SG-7E	.4375	.562	.437	1.812	1.125	.750	.625	.812	1.062	7/16-20	14	7,934	.198
SW-8E	SG-8E	.5000	.625	.500	2.125	1.312	.875	.750	.937	1.187	1/2-20	12	12,527	.329
SW-10E	SG-10E	.6250	.750	.562	2.500	1.500	1.000	.875	1.125	1.500	5/8-18	16	13,851	.477
SW-12E	SG-12E	.7500	.875	.687	2.875	1.750	1.125	1.000	1.312	1.750	3/4-16	14	21,664	.723
1 SW-16E	SG-16E	1.0000	1.375	1.000	4.125	2.750	1.625	1.500	1.875	2.125	1 1/4-12	14	61,333	2.125

Rod End No.		DIMENSIONS IN MILLIMETERS										a° Misalgn. Angle	Ultimate Radial Static Load Capacity Newtons	Approx. Brg. Wt. Grams
Right Hand	Left Hand	B + .038 - .013	W + .00 - .13	H ± .13	A ± .38	D ± .25	K ± .25	J ± .25	Ball Dia. Ref.	C + 1.57 - .79	Thread UNF-3B			
SW-3E	SG-3E	4.826	7.92	6.35	26.97	15.88	10.31	7.92	11.10	14.27	10-32	13	12,877	17
SW-4E	SG-4E	6.350	9.53	7.14	33.32	19.05	11.91	9.53	12.70	19.05	1/4-28	16	21,328	27
SW-5E	SG-5E	7.938	11.10	8.74	34.93	22.23	12.70	11.10	15.88	19.05	5/16-24	14	26,372	42
SW-6E	SG-6E	9.525	12.70	10.31	41.28	25.40	17.45	14.27	18.26	23.80	3/8-24	12	32,751	69
SW-7E	SG-7E	11.113	14.27	11.10	46.02	28.58	19.05	15.88	20.62	26.97	7/16-20	14	35,290	90
SW-8E	SG-8E	12.700	15.88	12.70	53.98	33.32	22.23	19.05	23.80	30.15	1/2-20	12	55,720	149
SW-10E	SG-10E	15.875	19.05	14.27	63.50	38.10	25.40	22.23	28.58	38.10	5/8-18	16	61,609	216
SW-12E	SG-12E	19.050	22.23	17.45	73.03	44.45	28.58	25.40	33.32	44.45	3/4-16	14	96,361	328
2 SW-16E	SG-16E	25.400	34.93	25.40	104.78	69.85	41.28	38.10	47.63	53.98	1 1/4-12	14	272,809	964

1 Tolerance variation: "D" ± .020, "A" ± .020, "B" + .0035, - .0005, "H" ± .010
 2 Tolerance variation: "D" ± .51, "A" ± .51, "B" + .089, - .013, "H" ± .25
 3 Above notes both have UNF-2B threads.

Units are supplied without grease fittings. When a grease fitting is required, specify by adding suffix as designated.
 Z Zerk type fitting Ex: SW-6EZ
 F Flush type fitting Ex: SW-6EF
 T PTFE liner Ex: SW-6ET



CM-S & CB-S Series Male Rod Ends With Studs

General Purpose - Economy

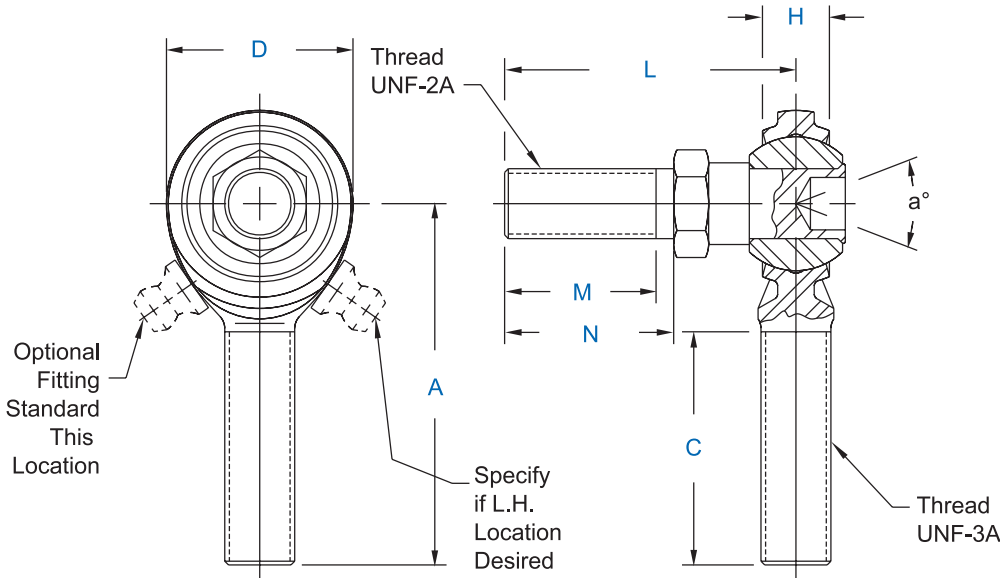

Optional grease fitting is supplied, standard, in **right hand** location as illustrated (with stud facing you). Specify if **left hand** location is desired.

Specifications
Body - Carbon steel, protective coated for corrosion resistance.
Ball - Sintered steel, heat treated, oil impregnated.
Stud - Carbon steel, protective coated for corrosion resistance. Right hand thread standard
Notes
Studs are available on all rod end series (Ex. - MM-8S). 2's & 16's available in "M" series.

Rod End No.		DIMENSIONS IN INCHES								a° Misalign. Angle	Ultimate Radial Static Load Capacity Lbs.	Approx. Brg. Wt. Lbs.
Right Hand	Left Hand	H Ref.	A ± .015	D Ref.	C + .062 - .031	L ± .015	N ± .010	M Ref.	Thread UNF-3A			
CM-3S*	CB-3S*	.234	1.250	.625	.750	1.000	.500	.437	10-32	50	Consult Aurora Bearing Engr. Dept.	.04
CM-4S*	CB-4S*	.250	1.562	.750	1.000	1.031	.562	500	1/4-28	50		.05
CM-5S*	CB-5S*	.312	1.875	.875	1.250	1.219	.687	.593	5/16-24	50		.10
CM-6S	CB-6S	.359	1.938	1.000	1.250	1.562	.906	.812	3/8-24	50		.15
CM-7S	CB-7S	.406	2.125	1.125	1.375	1.750	1.062	.937	7/16-20	50		.24
CM-8S	CB-8S	.453	2.438	1.312	1.500	2.000	1.125	1.000	1/2-20	50		.35
CM-10S	CB-10S	.484	2.625	1.500	1.625	2.500	1.500	1.375	5/8-18	50		.61
CM-12S	CB-12S	.593	2.875	1.750	1.750	3.000	1.812	1.625	3/4-16	50		1.03

Rod End No.		DIMENSIONS IN MILLIMETERS								a° Misalign. Angle	Ultimate Radial Static Load Capacity Newtons	Approx. Brg. Wt. Grams
Right Hand	Left Hand	H Ref.	A ± .38	D Ref.	C +1.57 - .79	L ± .38	N ±.25	M Ref.	Thread UNF-3A			
CM-3S*	CB-3S*	5.94	31.75	15.88	19.05	25.40	6.35	11.10	10-32	50	Consult Aurora Bearing Engr. Dept.	18
CM-4S*	CB-4S*	6.35	39.67	19.05	25.40	26.19	14.27	12.70	1/4-28	50		23
CM-5S*	CB-5S*	7.92	47.63	22.23	31.75	30.96	17.45	15.06	5/16-24	50		45
CM-6S	CB-6S	9.12	49.23	25.40	31.75	39.67	23.01	20.62	3/8-24	50		68
CM-7S	CB-7S	10.31	53.98	28.58	34.93	44.45	26.97	23.80	7/16-20	50		109
CM-8S	CB-8S	11.50	61.93	33.32	38.10	50.80	28.58	25.40	1/2-20	50		159
CM-10S	CB-10S	12.29	66.68	38.10	41.28	63.50	38.10	34.93	5/8-18	50		277
CM-12S	CB-12S	15.06	73.03	44.45	44.45	76.20	46.02	41.28	3/4-16	50		467

Load ratings apply only to rod ends without grease fittings.
For load ratings with fittings, please consult our engineering department.

* Grease fittings not available on these sizes. Units are supplied without grease fittings. When a grease fitting is required, specify by adding suffix as designated.

Z Zerk type fitting Ex: CM-6SZ
F Flush type fitting Ex: CM-6SF



CW-S & CG-S Series Female Rod Ends With Studs

General Purpose - Economy

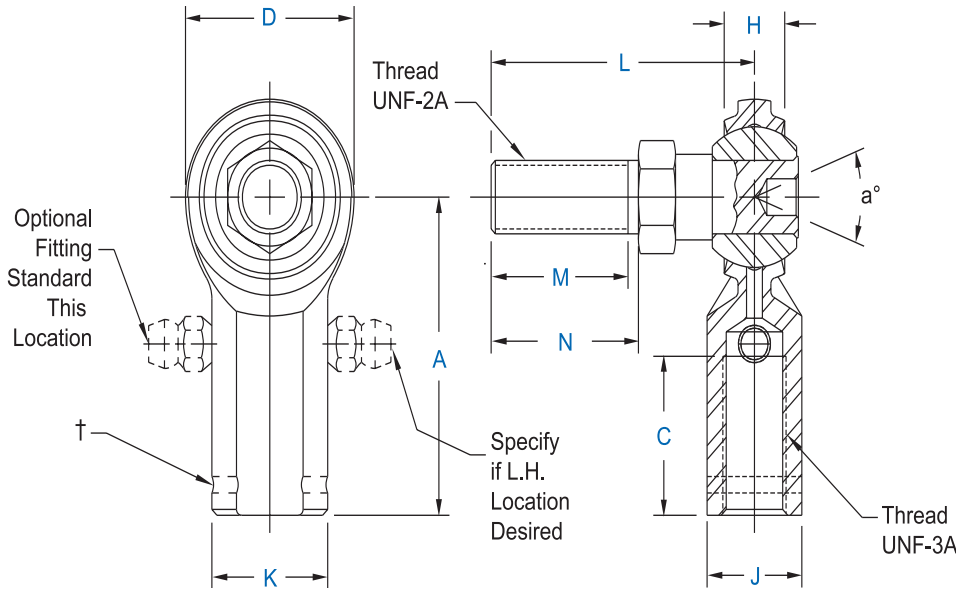

Optional grease fitting is supplied, standard, in **right hand** location as illustrated (with stud facing you). Specify if **left hand** location is desired.

Specifications
Body - Carbon steel, protective coated for corrosion resistance.
Ball - Sintered steel, heat treated, oil impregnated.
Stud - Carbon steel, protective coated for corrosion resistance. Right hand thread standard
Notes
Studs are available on all rod end series (Ex. - MW-8S). 2's & 16's available in "M" series.

Rod End No.		DIMENSIONS IN INCHES										a° Misaln. Angle	Ultimate Radial Static Load Capacity Lbs.	Approx. Brg. Wt. Lbs.					
Right Hand	Left Hand†	H Ref.	A ± .015	D Ref.	K ± .010	J ± .010	C + .062 - .031	L ± .015	N ± .010	M Ref.	Thread UNF-2B								
CW-3S*	CG-3S*	.234	1.062	.625	.406	.312	.500	1.000	.500	.437	10-32	Consult Aurora Bearing Engr. Dept.	.05						
CW-4S	CG-4S	.250	1.312	.750	.469	.375	.687	1.031	.562	.500	1/4-28			.06					
CW-5S	CG-5S	.312	1.375	.875	.500	.437	.687	1.219	.687	.593	5/16-24				.11				
CW-6S	CG-6S	.359	1.625	1.000	.687	.562	.812	1.562	.906	.812	3/8-24					.17			
CW-7S	CG-7S	.406	1.812	1.125	.750	.625	.937	1.750	1.062	.937	7/16-20						.27		
CW-8S	CG-8S	.453	2.125	1.312	.875	.750	1.062	2.000	1.125	1.000	1/2-20							.40	
CW-10S	CG-10S	.484	2.500	1.500	1.000	.875	1.375	2.500	1.500	1.375	5/8-18								.68
CW-12S	CG-12S	.593	2.875	1.750	1.125	1.000	1.562	3.000	1.812	1.625	3/4-16								

Rod End No.		DIMENSIONS IN MILLIMETERS										a° Misaln. Angle	Ultimate Radial Static Load Capacity Newtons	Approx. Brg. Wt. Grams					
Right Hand	Left Hand†	H Ref.	A ± .38	D Ref.	K ± .25	J ± .25	C + 1.57 - .79	L ± .38	N ± .25	M Ref.	Thread UNF-2B								
CW-3S*	CG-3S*	5.94	26.97	15.88	10.31	7.92	12.70	25.40	6.35	11.10	10-32	Consult Aurora Bearing Engr. Dept.	23						
CW-4S	CG-4S	6.35	33.32	19.05	11.91	9.53	17.45	26.19	14.27	12.70	1/4-28			27					
CW-5S	CG-5S	7.92	34.93	22.23	12.70	11.10	17.45	30.96	17.45	15.06	5/16-24				50				
CW-6S	CG-6S	9.12	41.28	25.40	17.45	14.27	20.62	39.67	23.01	20.62	3/8-24					77			
CW-7S	CG-7S	10.31	46.02	28.58	19.05	15.88	23.80	44.45	26.97	23.80	7/16-20						122		
CW-8S	CG-8S	11.50	53.98	33.32	22.23	19.05	26.97	50.80	28.58	25.40	1/2-20							181	
CW-10S	CG-10S	12.29	63.50	38.10	25.40	22.23	34.93	63.50	38.10	34.93	5/8-18								308
CW-12S	CG-12S	15.06	73.03	44.45	28.58	25.40	39.67	76.20	46.02	41.28	3/4-16								

† Left hand units have identification groove near end of shank.

* Grease fittings not available on these sizes. Units are supplied without grease fittings. When a grease fitting is required, specify by adding suffix as designated.

Z Zerk type fitting
F Flush type fitting

Ex: CW-6SZ
Ex: CW-6SF



Rod End Linkages Fixed or Adjustable Centers

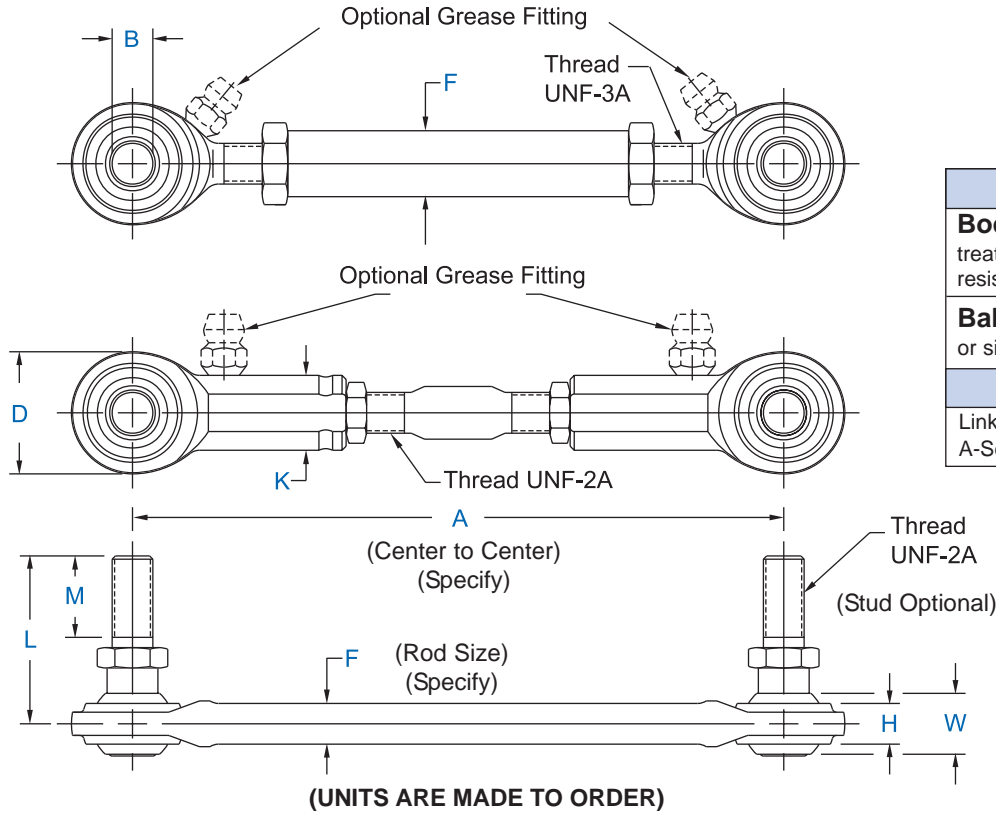

Specifications
Body - Carbon or Alloy steel, heat treated, protective coated for corrosion resistance.
Ball - Alloy heat treated, chrome plated or sintered steel, oil impregnated.
Notes
Linkages also available with M-Series, A-Series and all Metric Series rod ends.

*Link No.	DIMENSIONS IN INCHES										Misalignment Angle	
	B +.0025 -.0005	W ± .005	H ± .005	A	D ± .010	K Ref.	F	L ± .015	M Ref.	Thread UNF-2A	Clevis Mtd.	Stud Mtd.
	CL-3-	.1900	.312	.250		.625	.406		1.000	.437	10-32	13
CL-4-	.2500	.375	.281	OPTIONAL	.750	.469	OPTIONAL	1.031	.500	1/4-28	16	40
CL-5-	.3125	.437	.344	OPTIONAL	.875	.500	OPTIONAL	1.219	.593	5/16-24	14	42
CL-6-	.3750	.500	.406	OPTIONAL	1.000	.687	OPTIONAL	1.562	.812	3/8-24	12	46
CL-7-	.4375	.562	.437	OPTIONAL	1.125	.750	OPTIONAL	1.750	.937	7/16-20	14	44
CL-8-	.5000	.625	.500	OPTIONAL	1.312	.875	OPTIONAL	2.000	1.000	1/2-20	12	48

*Link No.	DIMENSIONS IN MILLIMETERS										Misalignment Angle	
	B + .064 - .013	W ± .13	H ± .13	A	D ± .25	K Ref.	F	L ± .38	M Ref.	Thread UNF-2A	Clevis Mtd.	Stud Mtd.
	CL-3-	4.826	7.92	6.35		15.88	10.31		25.40	11.10	10-32	13
CL-4-	6.350	9.53	7.14	OPTIONAL	19.05	11.91	OPTIONAL	26.19	12.70	1/4-28	16	40
CL-5-	7.938	11.10	8.74	OPTIONAL	22.23	12.70	OPTIONAL	30.96	15.06	5/16-24	14	42
CL-6-	9.525	12.70	10.31	OPTIONAL	25.40	17.45	OPTIONAL	39.67	20.62	3/8-24	12	46
CL-7-	11.113	14.27	11.10	OPTIONAL	28.58	19.05	OPTIONAL	44.45	23.80	7/16-20	14	44
CL-8-	12.700	15.88	12.70	OPTIONAL	33.32	22.23	OPTIONAL	50.80	25.40	1/2-20	12	48

*Suffix number will be added "A" and "F" optional dimensions.

Units are supplied without grease fittings. When a grease fitting is required, specify by adding suffix as designated.

Z Zerk type fitting
F Flush type fitting

Ex: CL-6Z
Ex: CL-6F

CM-M & CB-M Series
Male Rod Ends - Metric
 General Purpose - Economy



CW-M & CG-M Series
Female Rod Ends - Metric
 General Purpose - Economy

M E T R I C

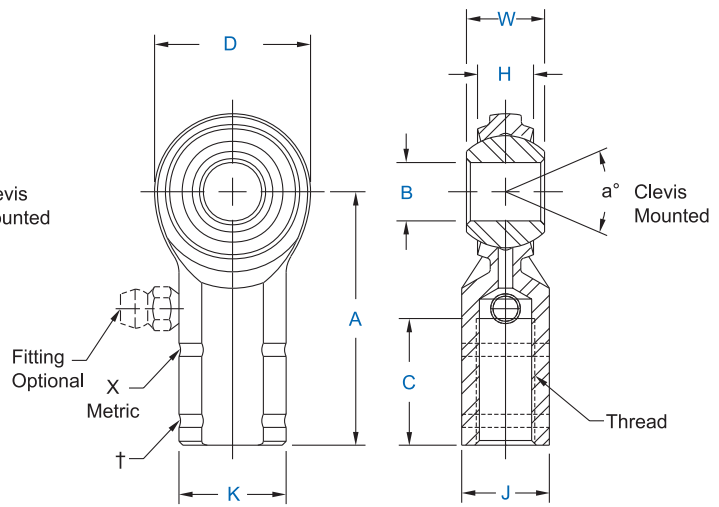
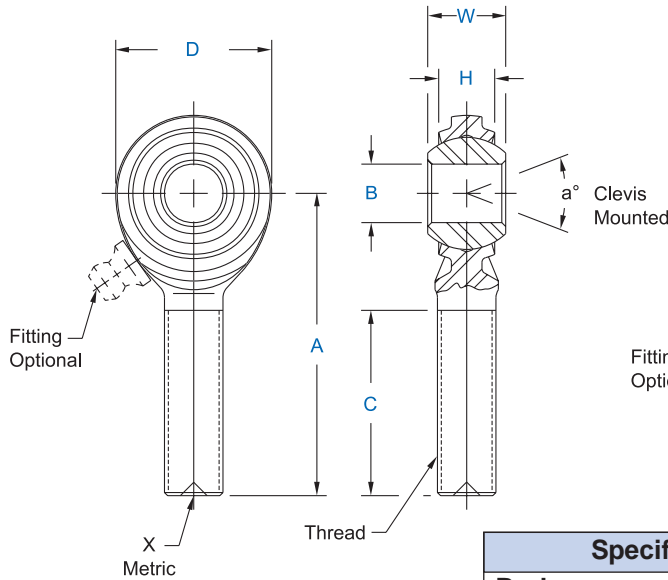

Specifications	
Body	Carbon steel, protective coated for corrosion resistance.
Ball	Sintered steel, heat treated, oil impregnated.
Alternate Ball	Alloy steel, heat treated, hard chrome plated.

Male

Rod End No.		DIMENSIONS IN MILLIMETERS								a° Misalign. Angle**			Ultimate Radial Static Load Capacity Newtons	Approx. Brg. Wt. Grams	
Right Hand	Left Hand	B +.065 -.013	W ± .13	H Ref.	A ± .40	D Ref.	Ball Dia. Ref.	C ± 1.00	Thread	a ₁	a ₃	a ₄			
*	CM-M3	CB-M3	3	6	4.25	27	12.50	7.93	15	M3 X 0.5	23	34	71	1,775	7
*	CM-M5	CB-M5	5	8	5.75	33	16.00	11.10	20	M5 X 0.8	22	30	64	5,168	12
	CM-M6	CB-M6	6	9	6.25	36	19.00	12.70	22	M6 X 1.0	23	31	65	7,296	18
	CM-M8	CB-M8	8	12	8.00	42	22.25	15.88	25	M8 X 1.25	28	38	59	13,591	31
	CM-M10	CB-M10	10	14	9.50	48	27.00	19.05	29	M10 X 1.5	26	35	57	21,024	68
	CM-M12	CB-M12	12	16	10.75	54	30.00	22.23	33	M12 X 1.75	27	34	57	25,819	78
*	CM-M14	CB-M14	14	19	12.25	60	34.75	25.40	36	M14 X 2.0	30	39	55	35,214	118
	CM-M16	CB-M16	16	21	12.75	66	38.00	28.58	40	M16 X 2.0	33	42	59	37,391	173
*	CM-M18	CB-M18	18	23	14.75	72	42.00	31.75	44	M18 X 1.5	30	37	56	47,903	260
	CM-M20	CB-M20	20	25	16.25	78	46.00	34.93	47	M20 X 1.5	29	36	55	57,101	290

*Check for availability. ** See page 4.

Z Zerk type fitting - CM-M10Z
 (Not available for 3, 5, 6, & 8).

Female

Rod End No.		DIMENSIONS IN MILLIMETERS								a° Misalign. Angle**			Ultimate Radial Static Load Capacity Newtons	Approx. Brg. Wt. Grams			
Right Hand	Left Hand	B +.065 -.013	W ± .13	H Ref.	A ± .40	D Ref.	K ± .25	J ± .25	Ball Dia. Ref.	C ± 1.00	Thread	a ₁			a ₃	a ₄	
*	CW-M3	CG-M3	3	6	4.25	21	12.50	8	7	7.93	10	M3 X 0.5	23	34	71	5,746	10
*	CW-M5	CG-M5	5	8	5.75	27	16.00	11	9	11.10	14	M5 X 0.8	22	30	64	8,247	18
	CW-M6	CG-M6	6	9	6.25	30	19.00	13	11	12.70	14	M6 X 1.0	23	31	65	11,895	25
	CW-M8	CG-M8	8	12	8.00	36	22.25	16	14	15.88	17	M8 X 1.25	28	38	59	15,190	40
	CW-M10	CG-M10	10	14	9.50	43	27.00	19	17	19.05	21	M10 X 1.5	26	35	57	22,750	80
	CW-M12	CG-M12	12	16	10.75	50	30.00	22	19	22.23	24	M12 X 1.75	27	34	57	25,819	95
*	CW-M14	CG-M14	14	19	12.25	57	34.75	25	22	25.40	27	M14 X 2.0	30	39	55	35,214	160
	CW-M16	CG-M16	16	21	12.75	64	38.00	27	22	28.58	33	M16 X 2.0	33	42	59	37,391	215
*	CW-M18	CG-M18	18	23	14.75	71	42.00	31	27	31.75	36	M18 X 1.5	30	37	56	47,903	300
	CW-M20	CG-M20	20	25	16.25	77	46.00	34	30	34.93	40	M20 X 1.5	29	36	55	57,101	350

*Check for availability. ** See page 4.
 X Designates metric threads.

†Left hand units have identification groove near end of shank.

Z Zerk type fitting - CW-M10Z
 (Not available for 3 & 5).



MM-M & MB-M Series Male Rod Ends - Metric
General Purpose - Precision

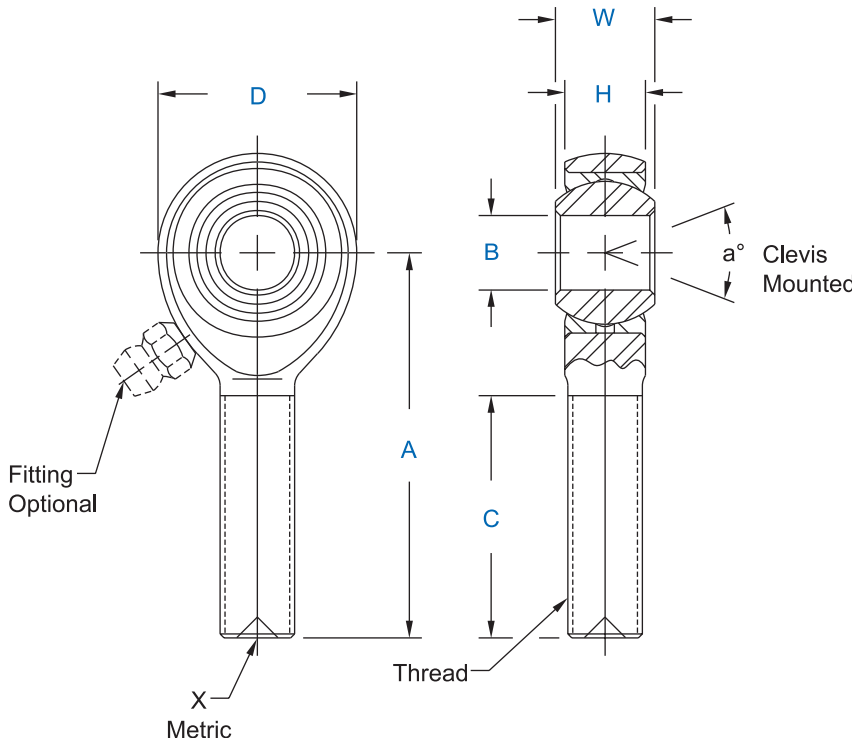

Specifications	
Body - Carbon steel, protective coated for corrosion resistance.	
Race - Carbon steel, protective coated for corrosion resistance.	
Ball - Alloy steel, heat treated, hard chrome plated.	

Rod End No.		DIMENSIONS IN MILLIMETERS								a° Misalign. Angle**			Ultimate Radial Static Load Capacity Newtons	Approx. Brg. Wt. Grams
Right Hand	Left Hand	B + .065 - .013	W ±.13	H ± .13	A ± .40	D ± .38	Ball Dia. Ref.	C ± 1.00	Thread	a ₁	a ₃	a ₄		
* ‡MM-M3	‡MB-M3	3	6	4.75	27	12.50	7.93	15	M3 X 0.5	13	25	62	1,775	7
MM-M5	MB-M5	5	8	6.25	33	16.00	11.10	20	M5 X 0.8	14	24	58	5,168	13
MM-M6	MB-M6	6	9	7.00	36	19.00	12.70	22	M6 X 1.0	13	23	57	7,296	18
MMF-M8	MBF-M8	8	12	8.75	42	22.25	15.88	25	M8 X 1.0	18	31	53	13,591	31
MM-M8	MB-M8								M8 X 1.25					
MMF-M10	MBF-M10	10	14	10.50	48	27.00	19.05	29	M10 X 1.25	17	28	50	20,603	68
MM-M10	MB-M10								M10 X 1.5					
MMF-M12	MBF-M12	12	16	12.00	54	30.00	22.23	33	M12 X 1.25	17	27	49	18,215	78
MM-M12	MB-M12								M12 X 1.75					
MMF-M14	MBF-M14	14	19	13.50	60	34.75	25.40	36	M14 X 1.5	21	33	49	29,840	118
MM-M14	MB-M14								M14 X 2.0					
MMF-M16	MBF-M16	16	21	14.25	66	38.00	28.58	40	M16 X 1.5	23	35	52	32,223	173
MM-M16	MB-M16								M16 X 2.0					
* MM-M18	MB-M18	18	23	16.25	72	42.00	31.75	44	M18 X 1.5	21	31	49	41,303	260
MMF-M20	MBF-M20	20	25	18.00	78	46.00	34.93	47	M20 X 1.5	20	29	48	50,952	290
MM-M20	MB-M20								M20 X 2.5					
* MM-M22	MB-M22	22	28	19.50	86	50.00	38.10	51	M22 X 1.5	22	33	48	56,238	315
* MM-M25	MB-M25	25	31	22.00	95	60.00	42.86	57	M24 X 2.0	19	31	47	104,435	500
* MM-M30	MB-M30	30	37	25.40	104.75	70.00	50.80	60	M30 X 2.0	21	33	47	147,238	1,090

*Check for availability.

** See page 4.

X Designates metric threads.

‡ Grease fitting not available on this size. Units are supplied without grease fittings. When a grease fitting is required, specify by adding suffix as designated.

Z Zerk type fitting Ex: MM-M10Z

F Flush type fitting Ex: MM-M10F

Load ratings apply only to rod ends without grease fittings.

For load ratings with fittings, please consult our engineering department.



MW-M & MG-M Series Female Rod Ends - Metric

General Purpose - Precision

M
E
T
R
I
C

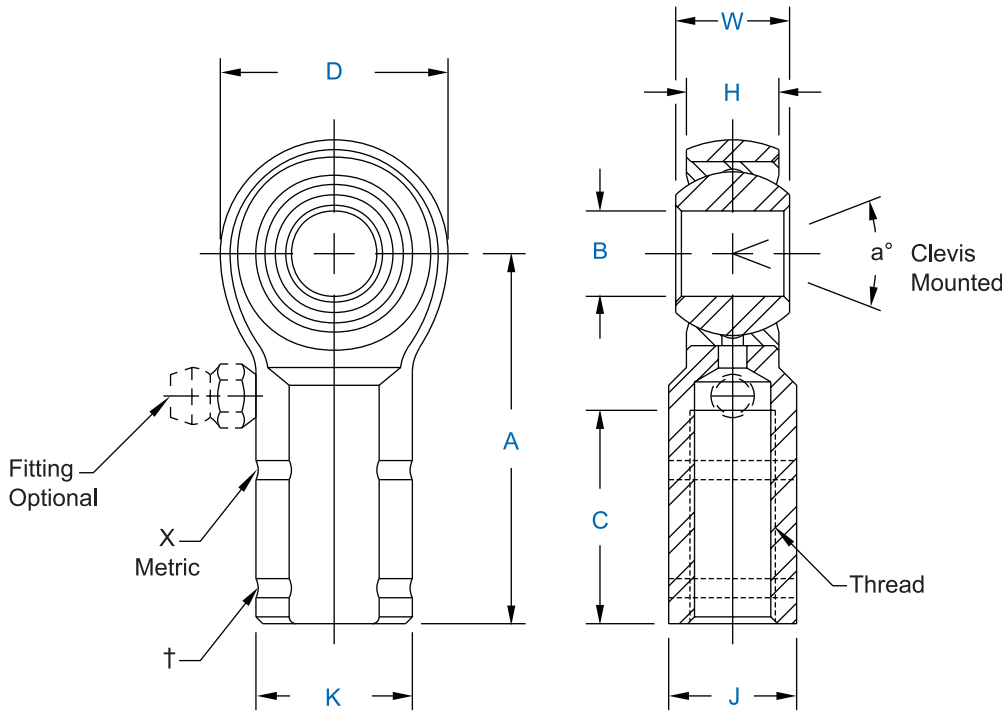

Specifications
Body - Carbon steel, protective coated for corrosion resistance.
Race - Carbon steel, protective coated for corrosion resistance.
Ball - Alloy steel, heat treated, hard chrome plated.

Rod End No.		DIMENSIONS IN MILLIMETERS										a° Misalign. Angle**			Ultimate Radial Static Capacity Newtons	Approx. Brg. Wt. Grams
Right Hand	Left Hand†	B +.065 -.013	W ± .13	H ± .13	A ± .40	D ± .38	K ± .25	J ± .25	Ball Dia. Ref.	C ± 1.00	Thread	a ₁	a ₃	a ₄		
* ‡ MW-M3	‡ MG-M3	3	6	4.75	21	12.50	8	7	7.93	10	M3 X 0.5	13	25	62	4,972	10
MW-M5	MG-M5	5	8	6.25	27	16.00	11	9	11.10	14	M5 X 0.8	14	24	58	7,090	17
MW-M6	MG-M6	6	9	7.00	30	19.00	13	11	12.70	14	M6 X 1.0	13	23	57	10,573	25
MWF-M8	MGF-M8	8	12	8.75	36	22.25	16	14	15.88	17	M8 X 1.0	18	31	53	14,072	40
MW-M8	MG-M8										M8 X 1.25					
MWF-M10	MGF-M10	10	14	10.50	43	27.00	19	17	19.05	21	M10 X 1.25	17	28	50	20,603	80
MW-M10	MG-M10										M10 X 1.5					
MWF-M12	MGF-M12	12	16	12.00	50	30.00	22	19	22.23	24	M12 X 1.25	17	27	49	18,215	95
MW-M12	MG-M12										M12 X 1.75					
MWF-M14	MGF-M14	14	19	13.50	57	34.75	25	22	25.40	27	M14 X 1.5	21	33	49	29,840	160
MW-M14	MG-M14										M14 X 2.0					
MWF-M16	MGF-M16	16	21	14.25	64	38.00	27	22	28.58	33	M16 X 1.5	23	35	52	32,223	215
MW-M16	MG-M16										M16 X 2.0					
* MW-M18	MG-M18	18	23	16.25	71	42.00	31	27	31.75	36	M18 X 1.5	21	31	49	41,303	300
MWF-M20	MGF-M20	20	25	18.00	77	46.00	34	30	34.93	40	M20 X 1.5	20	29	48	50,952	350
MW-M20	MG-M20										M20 X 2.5					
* MW-M22	MG-M22	22	28	19.50	86	50.00	37	32	38.10	43	M22 X 1.5	22	33	48	56,238	390
MW-M25	MG-M25	25	31	22.00	95	60.00	42	36	42.86	48	M24 X 2.0	19	31	47	104,435	700
* MW-M30	MG-M30	30	37	25.40	104.75	70.00	41.25	38.10	50.80	54	M30 X 2.0	21	33	47	147,238	970

*Check for availability.

** See page 4.

X Designates metric threads.

†Left hand units have identification groove.

‡ Grease fitting not available on this size. Units are supplied without grease fittings. When a grease fitting is required, specify by adding suffix as designated.

Z Zerk type fitting Ex: MW-M10Z

F Flush type fitting Ex: MW-M10F



**MM-MT & MB-MT Series Male Rod Ends
(PTFE) Lined - Metric**
General Purpose - Precision - Self-Lubricating

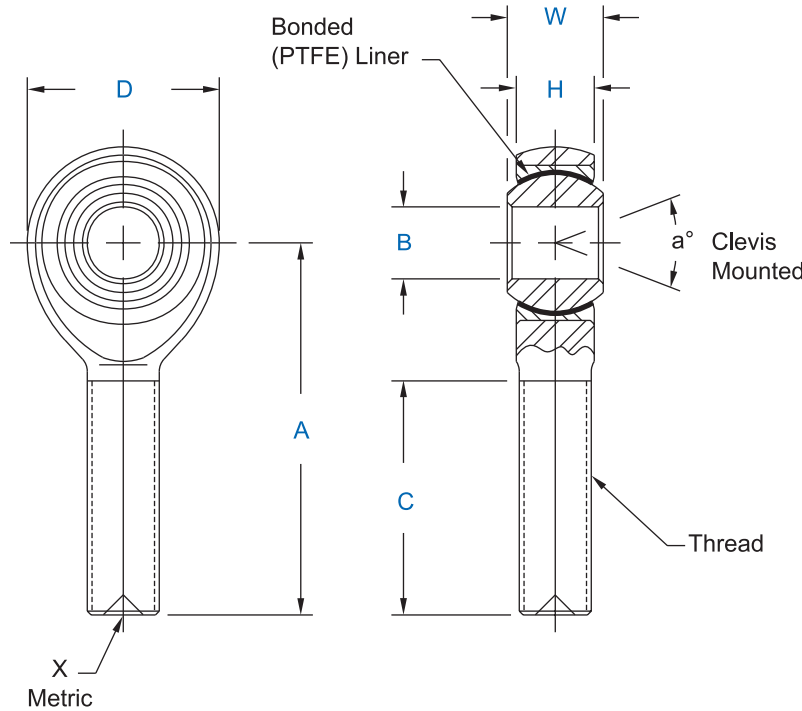

Specifications	
Body - Carbon steel, protective coated for corrosion resistance.	
Race - Carbon steel, protective coated for corrosion resistance, PTFE lined.	
Ball - Alloy steel, heat treated, hard chrome plated.	

Rod End No.		DIMENSIONS IN MILLIMETERS								a° Misalign. Angle**			Ultimate Radial Static Load Capacity Newtons	Approx. Brg. Wt. Grams
Right Hand	Left Hand	B + .065 - .013	W ±.13	H ± .13	A ± .40	D ± .38	Ball Dia. Ref.	C ± 1.00	Thread	a ₁	a ₃	a ₄		
*	MM-M3T MB-M3T	3	6	4.75	27	12.50	7.93	15	M3 X 0.5	13	25	62	1,775	7
	MM-M5T MB-M5T	5	8	6.25	33	16.00	11.10	20	M5 X 0.8	14	24	58	5,168	13
	MM-M6T MB-M6T	6	9	7.00	36	19.00	12.70	22	M6 X 1.0	13	23	57	7,296	18
	MMF-M8T MBF-M8T	8	12	8.75	42	22.25	15.88	25	M8 X 1.0	18	31	53	13,591	31
	MM-M8T MB-M8T								M8 X 1.25					
	MMF-M10T MBF-M10T	10	14	10.50	48	27.00	19.05	29	M10 X 1.25	17	28	50	20,603	68
	MM-M10T MB-M10T								M10 X 1.5					
	MMF-M12T MBF-M12T	12	16	12.00	54	30.00	22.23	33	M12 X 1.25	17	27	49	18,215	78
	MM-M12T MB-M12T								M12 X 1.75					
	MMF-M14T MBF-M14T	14	19	13.50	60	34.75	25.40	36	M14 X 1.5	21	33	49	29,840	118
	MM-M14T MB-M14T								M14 X 2.0					
	MMF-M16T MBF-M16T	16	21	14.25	66	38.00	28.58	40	M16 X 1.5	23	35	52	32,223	173
	MM-M16T MB-M16T								M16 X 2.0					
*	MM-M18T MB-M18T	18	23	16.25	72	42.00	31.75	44	M18 X 1.5	21	31	49	41,303	260
	MMF-M20T MBF-M20T	20	25	18.00	78	46.00	34.93	47	M20 X 1.5	20	29	48	50,952	290
	MM-M20T MB-M20T								M20 X 2.5					
*	MM-M22T MB-M22T	22	28	19.50	86	50.00	38.10	51	M22 X 1.5	22	33	48	56,238	315
*	MM-M25T MB-M25T	25	31	22.00	95	60.00	42.86	57	M24 X 2.0	19	31	47	104,435	500
*	MM-M30T MB-M30T	30	37	25.40	104.75	70.00	50.80	60	M30 X 2.0	21	33	47	147,238	1,090

*Check for availability.

** See page 4.

X Designates metric threads.



MW-MT & MG-MT Series Female Rod Ends (PTFE) Lined- Metric

General Purpose - Precision - Self-Lubricating



METRIC

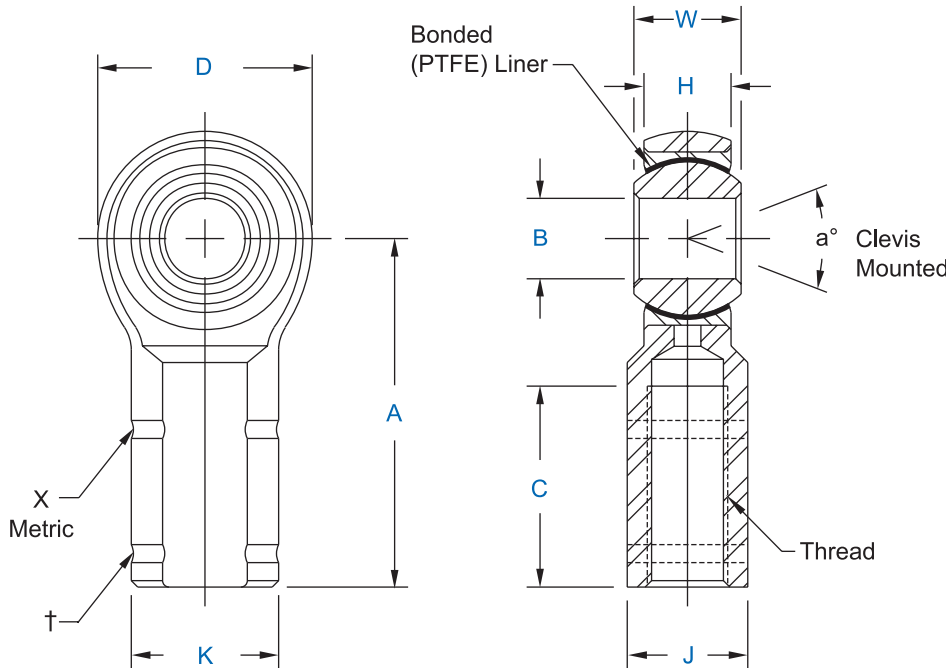

Specifications	
Body	Carbon steel, protective coated for corrosion resistance.
Race	Carbon steel, protective coated for corrosion resistance, PTFE lined.
Ball	Alloy steel, heat treated, hard chrome plated.

Rod End No.		DIMENSIONS IN MILLIMETERS										a° Misalign. Angle**			Ultimate Radial Static Load Capacity Newtons	Approx. Brg. Wt. Grams
Right Hand	Left Hand†	B +.065 - .013	W ± .13	H ± .13	A ± .40	D ± .38	K ± .25	J ± .25	Ball Dia. Ref.	C ± 1.00	Thread	a ₁	a ₃	a ₄		
* MW-M3T	MG-M3T	3	6	4.75	21	12.50	8	7	7.93	10	M3 X 0.5	13	25	62	4,972	10
MW-M5T	MG-M5T	5	8	6.25	27	16.00	11	9	11.10	14	M5 X 0.8	14	24	58	7,090	17
MW-M6T	MG-M6T	6	9	7.00	30	19.00	13	11	12.70	14	M6 X 1.0	13	23	57	10,573	25
MWF-M8T	MGF-M8T	8	12	8.75	36	22.25	16	14	15.88	17	M8 X 1.0	18	31	53	14,072	40
MW-M8T	MG-M8T										M8 X 1.25					
MWF-M10T	MGF-M10T	10	14	10.50	43	27.00	19	17	19.05	21	M10 X 1.25	17	28	50	20,603	80
MW-M10T	MG-M10T										M10 X 1.5					
MWF-M12T	MGF-M12T	12	16	12.00	50	30.00	22	19	22.23	24	M12 X 1.25	17	27	49	18,215	95
MW-M12T	MG-M12T										M12 X 1.75					
MWF-M14T	MGF-M14T	14	19	13.50	57	34.75	25	22	25.40	27	M14 X 1.5	21	33	49	29,840	160
MW-M14T	MG-M14T										M14 X 2.0					
MWF-M16T	MGF-M16T	16	21	14.25	64	38.00	27	22	28.58	33	M16 X 1.5	23	35	52	32,223	215
MW-M16T	MG-M16T										M16 X 2.0					
* MW-M18T	MG-M18T	18	23	16.25	71	42.00	31	27	31.75	36	M18 X 1.5	21	31	49	41,303	300
MWF-M20T	MGF-M20T	20	25	18.00	77	46.00	34	30	34.93	40	M20 X 1.5	20	29	48	50,952	350
* MW-M20T	MG-M20T										M20 X 2.5					
* MW-M22T	MG-M22T	22	28	19.50	86	50.00	37	32	38.10	43	M22 X 1.5	22	33	48	56,238	390
* MW-M25T	MG-M25T	25	31	22.00	95	60.00	42	36	42.86	48	M24 X 2.0	19	31	47	104,435	700
* MW-M30T	MG-M30T	30	37	25.40	104.75	70.00	41.25	38.10	50.80	54	M30 X 2.0	21	33	47	147,238	970

* Check for availability.

** See page 4.

X Designates metric threads.

†Left hand units have identification groove.



KM-M & KB-M Series Male Rod Ends - Metric
Wear Resistant - Precision

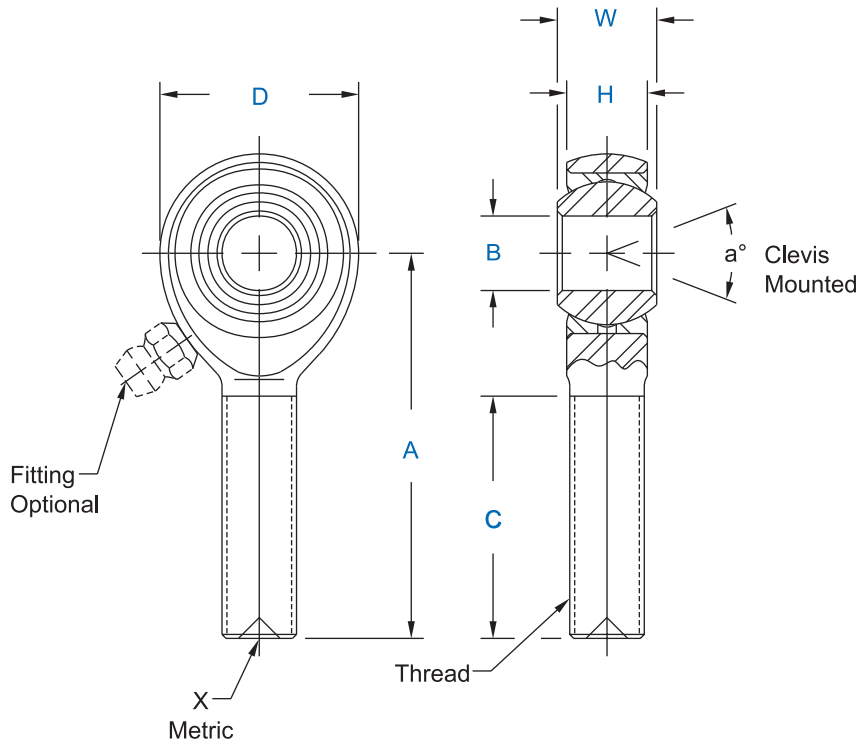

Specifications	
Body	Carbon steel, protective coated for corrosion resistance.
Race	Alloy steel, heat treated, protective coated for corrosion resistance.
Ball	Alloy steel, heat treated, hard chrome plated.

Rod End No.		DIMENSIONS IN MILLIMETERS								a° Misalign. Angle**			Ultimate Radial Static Load Capacity Newtons	Approx. Brg. Wt. Grams
Right Hand	Left Hand	B + .065 - .013	W ± .13	H ± .13	A ± .40	D ± .38	Ball Dia. Ref.	C ± 1.00	Thread	a ₁	a ₃	a ₄		
* ‡KM-M3	‡KB-M3	3	6	4.75	27	12.50	7.93	15	M3 X 0.5	13	25	62	1,775	7
KM-M5	KB-M5	5	8	6.25	33	16.00	11.10	20	M5 X 0.8	14	24	58	5,168	13
KM-M6	KB-M6	6	9	7.00	36	19.00	12.70	22	M6 X 1.0	13	23	57	7,296	18
KMF-M8	KBF-M8	8	12	8.75	42	22.25	15.88	25	M8 X 1.0	18	31	53	13,591	31
KM-M8	KB-M8								M8 X 1.25					
KMF-M10	KBF-M10	10	14	10.50	48	27.00	19.05	29	M10 X 1.25	17	28	50	20,603	68
KM-M10	KB-M10								M10 X 1.5					
KMF-M12	KBF-M12	12	16	12.00	54	30.00	22.23	33	M12 X 1.25	17	27	49	18,215	78
KM-M12	KB-M12								M12 X 1.75					
KMF-M14	KBF-M14	14	19	13.50	60	34.75	25.40	36	M14 X 1.5	21	33	49	29,840	118
KM-M14	KB-M14								M14 X 2.0					
KMF-M16	KBF-M16	16	21	14.25	66	38.00	28.58	40	M16 X 1.5	23	35	52	32,223	173
KM-M16	KB-M16								M16 X 2.0					
* KM-M18	KB-M18	18	23	16.25	72	42.00	31.75	44	M18 X 1.5	21	31	49	41,303	260
KMF-M20	KBF-M20	20	25	18.00	78	46.00	34.93	47	M20 X 1.5	20	29	48	50,952	290
KM-M20	KB-M20								M20 X 2.5					
* KM-M22	KB-M22	22	28	19.50	86	50.00	38.10	51	M22 X 1.5	22	33	48	56,238	315
* KM-M25	KB-M25	25	31	22.00	95	60.00	42.86	57	M24 X 2.0	19	31	47	104,435	500
* KM-M30	KB-M30	30	37	25.40	104.75	70.00	50.80	60	M30 X 2.0	21	33	47	140,570	1,090

*Check for availability.

** See page 4.

X Designates metric threads.

‡ Grease fitting not available on this size. Units are supplied without grease fittings. When a grease fitting is required, specify by adding suffix as designated.

Z Zerk type fitting

F Flush type fitting

Ex: KM-M10Z

Ex: KM-M10F

Load ratings apply only to rod ends without grease fittings. For load ratings with fittings, please consult our engineering department.



KW-M & KG-M Series Female Rod Ends - Metric

Wear Resistant - Precision

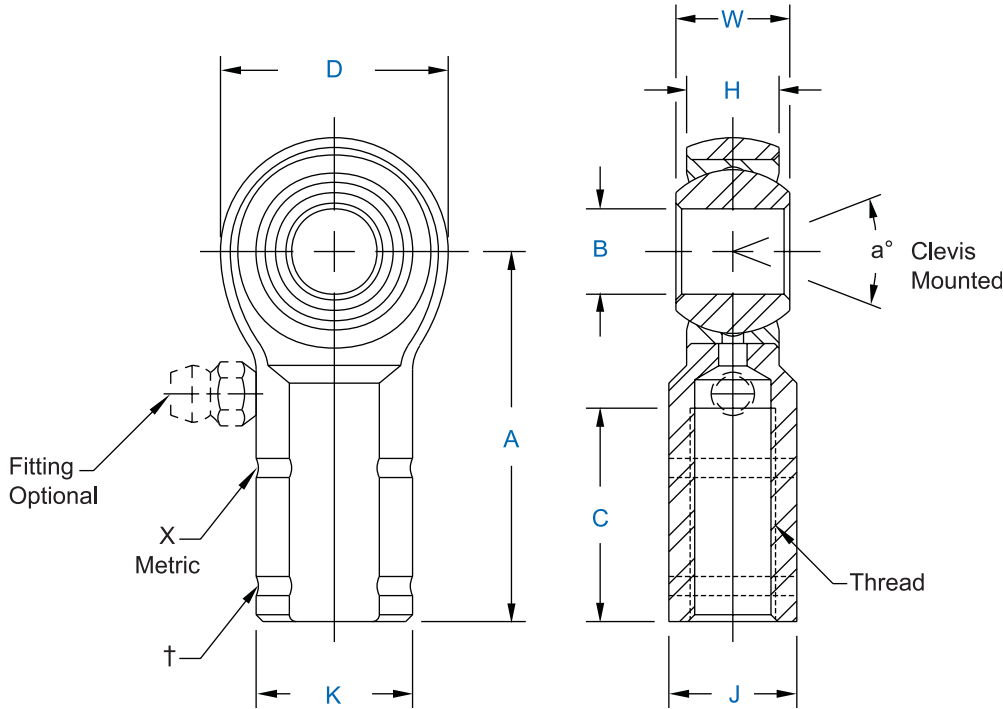

Specifications
Body - Carbon steel, protective coated for corrosion resistance.
Race - Alloy steel, heat treated, protective coated for corrosion resistance.
Ball - Alloy steel, heat treated, hard chrome plated.

Rod End No.		DIMENSIONS IN MILLIMETERS										a° Misalign. Angle**			Ultimate Radial Static Capacity Newtons	Approx. Brg. Wt. Grams
Right Hand	Left Hand†	B +.065 -.013	W ± .13	H ± .13	A ± .40	D ± .38	K ± .25	J ± .25	Ball Dia. Ref.	C ± 1.00	Thread	a ₁	a ₃	a ₄		
* ±KW-M3	±KG-M3	3	6	4.75	21	12.50	8	7	7.93	10	M3 X 0.5	13	25	62	4,972	10
KW-M5	KG-M5	5	8	6.25	27	16.00	11	9	11.10	14	M5 X 0.8	14	24	58	7,090	17
KW-M6	KG-M6	6	9	7.00	30	19.00	13	11	12.70	14	M6 X 1.0	13	23	57	10,573	25
KWF-M8	KGF-M8	8	12	8.75	36	22.25	16	14	15.88	17	M8 X 1.0	18	31	53	14,072	40
KW-M8	KG-M8										M8 X 1.25					
KWF-M10	KGF-M10	10	14	10.50	43	27.00	19	17	19.05	21	M10 X 1.25	17	28	50	20,603	80
KW-M10	KG-M10										M10 X 1.5					
KWF-M12	KGF-M12	12	16	12.00	50	30.00	22	19	22.23	24	M12 X 1.25	17	27	49	18,215	95
KW-M12	KG-M12										M12 X 1.75					
KWF-M14	KGF-M14	14	19	13.50	57	34.75	25	22	25.40	27	M14 X 1.5	21	33	49	29,840	160
KW-M14	KG-M14										M14 X 2.0					
KWF-M16	KGF-M16	16	21	14.25	64	38.00	27	22	28.58	33	M16 X 1.5	23	35	52	32,223	215
KW-M16	KG-M16										M16 X 2.0					
* KW-M18	KG-M18	18	23	16.25	71	42.00	31	27	31.75	36	M18 X 1.5	21	31	49	41,303	300
KWF-M20	KGF-M20	20	25	18.00	77	46.00	34	30	34.93	40	M20 X 1.5	20	29	48	50,952	350
KW-M20	KG-M20										M20 X 2.5					
* KW-M22	KG-M22	22	28	19.50	86	50.00	37	32	38.10	43	M22 X 1.5	22	33	48	56,238	390
* KW-M25	KG-M25	25	31	22.00	95	60.00	42	36	42.86	48	M24 X 2.0	19	31	47	104,435	700
* KW-M30	KG-M30	30	37	25.40	104.75	70.00	41.25	38.10	50.80	54	M30 X 2.0	21	33	47	147,238	970

*Check for availability.

** See page 4.

X Designates metric threads.

† Left hand units have identification groove.

‡ Grease fitting not available on this size. Units are supplied without grease fittings. When a grease fitting is required, specify by adding suffix as designated.

Z Zerk type fitting

F Flush type fitting

Ex: KW-M10Z

Ex: KW-M10F



AM-M & AB-M Series Male Rod Ends - Metric
High Strength Alloy - Precision - (PTFE Liners Available)

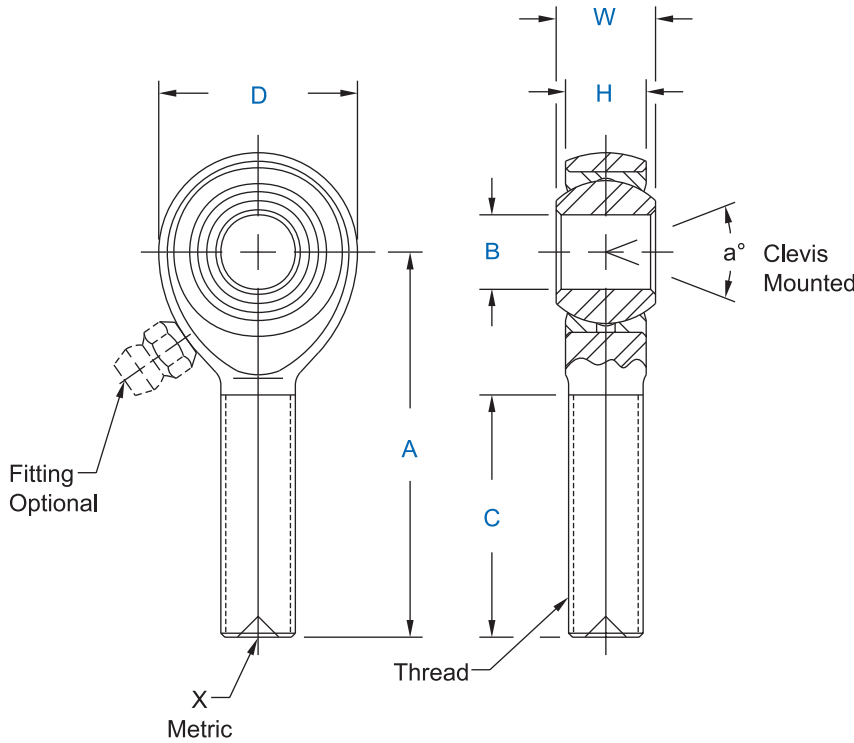

Specifications	
Body - Alloy steel, heat treated, protective coated for corrosion resistance.	
Race - Alloy steel, heat treated, protective coated for corrosion resistance.	
Ball - Alloy steel, heat treated, hard chrome plated.	

Rod End No.		DIMENSIONS IN MILLIMETERS								a° Misalign. Angle**			Ultimate Radial Static Load Capacity Newtons	Approx. Brg. Wt. Grams
Right Hand	Left Hand	B + .065 - .013	W ± .13	H ± .13	A ± .40	D ± .38	Ball Dia. Ref.	C ± 1.00	Thread	a ₁	a ₃	a ₄		
* ‡AM-M3	‡AB-M3	3	6	4.75	27	12.50	7.93	15	M3 X 0.5	13	25	62	4,344	7
AM-M5	AB-M5	5	8	6.25	33	16.00	11.10	20	M5 X 0.8	14	24	58	12,611	13
AM-M6	AB-M6	6	9	7.00	36	19.00	12.70	22	M6 X 1.0	13	23	57	17,720	18
AMF-M8	ABF-M8	8	12	8.75	42	22.25	15.88	25	M8 X 1.0	18	31	53	33,135	31
AM-M8	AB-M8								M8 X 1.25					
AMF-M10	ABF-M10	10	14	10.50	48	27.00	19.05	29	M10 X 1.25	17	28	50	50,227	68
AM-M10	AB-M10								M10 X 1.5					
AMF-M12	ABF-M12	12	16	12.00	54	30.00	22.23	33	M12 X 1.25	17	27	49	44,490	78
AM-M12	AB-M12								M12 X 1.75					
AMF-M14	ABF-M14	14	19	13.50	60	34.75	25.40	36	M14 X 1.5	21	33	49	71,741	118
AM-M14	AB-M14								M14 X 2.0					
AMF-M16	ABF-M16	16	21	14.25	66	38.00	28.58	40	M16 X 1.5	23	35	52	76,291	173
AM-M16	AB-M16								M16 X 2.0					
AM-M18	AB-M18	18	23	16.25	72	42.00	31.75	44	M18 X 1.5	21	31	49	100,738	260
AMF-M20	ABF-M20	20	25	18.00	78	46.00	34.93	47	M20 X 1.5	20	29	48	120,212	290
AM-M20	AB-M20								M20 X 2.5					
AM-M22	AB-M22	22	28	19.50	86	50.00	38.10	51	M22 X 1.5	22	33	48	137,099	315
AM-M25	AB-M25	25	31	22.00	95	60.00	42.86	57	M24 X 2.0	19	31	47	251,780	500
AM-M30	AB-M30	30	37	25.40	104.75	70.00	50.80	60	M30 X 2.0	21	33	47	342,712	1,090

*Check for availability.

** See page 4.

X Designates metric threads.

‡ Grease fitting not available on this size. Units are supplied without grease fittings. When a grease fitting is required, specify by adding suffix as designated.

Z Zerk type fitting

Ex: AM-M10Z

F Flush type fitting

Ex: AM-M10F

T PTFE Liner

Ex: AM-M10T

Load ratings apply only to rod ends without grease fittings. For load ratings with fittings, please consult our engineering department.



AW-M & AG-M Series Female Rod Ends - Metric

High Strength Alloy - Precision - (PTFE Liners Available)

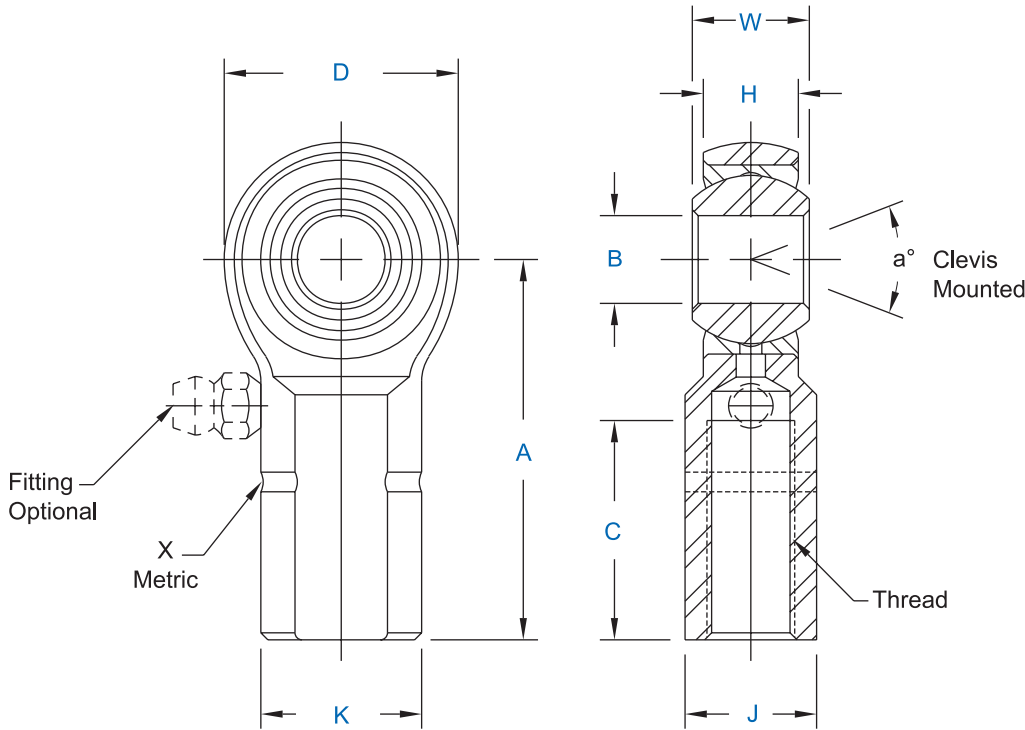

Specifications
Body - Alloy steel, heat treated, protective coated for corrosion resistance.
Race - Alloy steel, heat treated, protective coated for corrosion resistance.
Ball - Alloy steel, heat treated, hard chrome plated.

Rod End No.		DIMENSIONS IN MILLIMETERS										a° Misalign. Angle**			Ultimate Radial Static Load Capacity Newtons	Approx. Brg. Wt. Grams	
		Right Hand	Left Hand	B +.065 -.013	W ± .13	H ± .13	A ± .40	D ± .38	K ± .25	J ± .25	Ball Dia. Ref.	C ± 1.00	Thread	a ₁			a ₃
*	‡AW-M3	‡AG-M3	3	6	4.75	21	12.50	8	7	7.93	10	M3 X 0.5	13	25	62	11,346	10
	AW-M5	AG-M5	5	8	6.25	27	16.00	11	9	11.10	14	M5 X 0.8	14	24	58	16,396	17
	AW-M6	AG-M6	6	9	7.00	30	19.00	13	11	12.70	14	M6 X 1.0	13	23	57	25,781	25
	AWF-M8	AGF-M8	8	12	8.75	36	22.25	16	14	15.88	17	M8 X 1.0	18	31	53	33,203	40
	AW-M8	AG-M8										M8 X 1.25					
	AWF-M10	AGF-M10	10	14	10.50	43	27.00	19	17	19.05	21	M10 X 1.25	17	28	50	50,227	80
	AW-M10	AG-M10										M10 X 1.5					
	AWF-M12	AGF-M12	12	16	12.00	50	30.00	22	19	22.23	24	M12 X 1.25	17	27	49	44,490	95
	AW-M12	AG-M12										M12 X 1.75					
	AWF-M14	AGF-M14	14	19	13.50	57	34.75	25	22	25.40	27	M14 X 1.5	21	33	49	71,741	160
	AW-M14	AG-M14										M14 X 2.0					
	AWF-M16	AGF-M16	16	21	14.25	64	38.00	27	22	28.58	33	M16 X 1.5	23	35	52	76,291	215
	AW-M16	AG-M16										M16 X 2.0					
*	AW-M18	AG-M18	18	23	16.25	71	42.00	31	27	31.75	36	M18 X 1.5	21	31	49	100,738	300
	AWF-M20	AGF-M20	20	25	18.00	77	46.00	34	30	34.93	40	M20 X 1.5	20	29	48	120,212	350
	AW-M20	AG-M20										M20 X 2.5					
*	AW-M22	AG-M22	22	28	19.50	86	50.00	37	32	38.10	43	M22 X 1.5	22	33	48	137,099	390
*	AW-M25	AG-M25	25	31	22.00	95	60.00	42	36	42.86	48	M24 X 2.0	19	31	47	251,780	700
*	AW-M30	AG-M30	30	37	25.40	104.75	70.00	41.25	38.10	50.80	54	M30 X 2.0	21	33	47	342,712	970

*Check for availability.

** See page 4.

X Designates metric threads.

‡ Grease fitting not available on this size. Units are supplied without grease fittings. When a grease fitting is required, specify by adding suffix as designated.

Z Zerk type fitting

F Flush type fitting

T PTFE Liner

Ex: AW-M10Z

Ex: AW-M10F

Ex: AW-M10T



COM-M Series Spherical Bearings - Metric
(PTFE Liners Available)¹

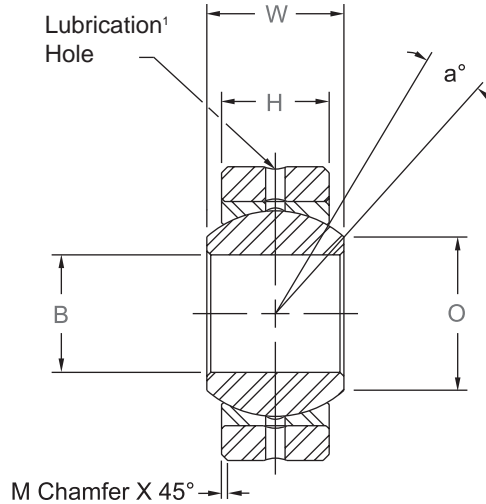
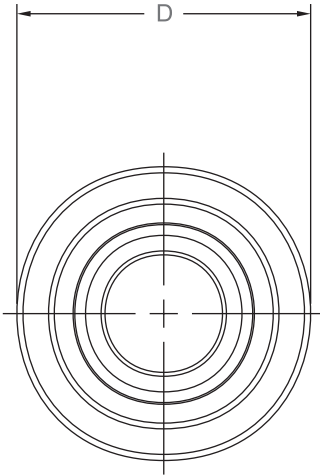

Specifications	
Outer Member	Carbon steel, protective coated for corrosion resistance.
Race	Carbon steel, I.D. protective coated for corrosion resistance.
Ball	Alloy steel, heat treated, hard chrome plated.

Bearing No.	DIMENSIONS IN MILLIMETERS							a° Misalign. Angle	Radial Static Load Capacity Newtons ²	Approx. Brg. Wt. Grams
	B + .065 - .013	D + .000 - .018	H ± .13	W ± .13	O Flat Dia Ref.	M Chamfer Ref.	Ball Dia. Ref.			
* COM-M3	3	12	4.50	6	5.19	.5	7.93	13.5	14,758	4
* COM-M5	5	16	6.00	8	7.68	.5	11.10	12.5	27,555	9
COM-M6	6	18	6.75	9	8.93	.5	12.70	12.5	35,459	13
COM-M8	8	22	9.00	12	10.35	.8	15.88	14.0	59,121	24
COM-M10	10	26	10.50	14	12.88	.8	19.05	13.5	82,744	40
COM-M12	12	30	12.00	16	15.39	.8	22.23	13.0	112,829	80
COM-M14	14	34	13.50	19	16.86	1.0	25.40	16.0	141,845	110
COM-M16	16	38	15.00	21	19.34	1.0	28.58	15.0	177,343	130
* COM-M18	18	42	16.50	23	21.89	1.0	31.75	15.0	216,714	170
COM-M20	20	46	18.00	25	24.35	1.0	34.93	14.5	260,086	230
* COM-M22	22	50	20.00	28	25.84	1.5	38.10	15.0	315,216	280
* COM-M25	25	56	22.00	31	29.60	1.5	42.86	15.0	390,056	390
* COM-M30	30	66	25.00	37	34.81	1.5	50.80	17.0	525,360	610

* Check for availability.
¹ PTFE Liners use suffix T Ex: COM-M10T
 (PTFE Liners have no lubrication holes or groove in race)
² Based upon maximum permanent set of .5% of ball O.D. (See page 4)



COM & HCOM Series Spherical Bearings (PTFE Liners Available)¹

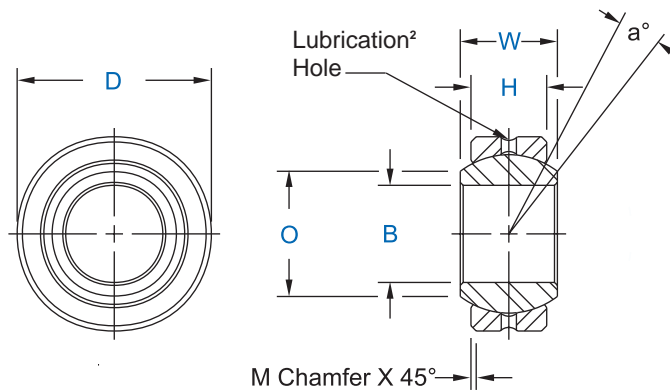

Specifications
Race - Carbon steel, I.D. protective coated for corrosion resistance.
Ball - Alloy steel, heat treated, hard chrome plated.

Bearing No.	DIMENSIONS IN INCHES							a° Misalign. Angle	Radial Static Load Capacity Lbs.	Approx. Brg. Wt. Lbs.
	B + .0015 - .0005	D + .0000 - .0007	H ± .005	W ± .005	O Flat Dia Ref.	M Chamfer Ref.	Ball Dia. Ref.			
COM-3	.1900	.5625	.218	.281	.293	.015	.406	11	3,250	.014
COM-4	.2500	.6562	.250	.343	.364	.022	.500	13.5	4,950	.022
COM-5	.3125	.7500	.281	.375	.419	.032	.562	12	6,475	.030
COM-6	.3750	.8125	.312	.406	.516	.032	.656	10	8,400	.038
COM-7	.4375	.9062	.343	.437	.530	.032	.687	8	9,453	.047
COM-8	.5000	1.0000	.390	.500	.640	.032	.813	9.5	13,250	.065
COM-9	.5625	1.0937	.437	.562	.710	.032	.906	9.5	16,630	.086
COM-10	.6250	1.1875	.500	.625	.780	.032	1.000	8.5	21,280	.110
COM-12	.7500	1.4375	.593	.750	.920	.044	1.187	9	31,920	.204
COM-14	.8750	1.5625	.703	.875	.980	.044	1.312	9.5	41,960	.263
*COM-16	1.0000	1.7500	.797	1.000	1.118	.044	1.500	10	55,200	.386
*HCOM-16	1.0000	2.0000	.781	1.000	1.360	.032	1.687	9	70,820	.553
*HCOM-19	1.1875	2.3750	.937	1.187	1.610	.032	2.000	8.5	100,730	.895
*HCOM-20	1.2500	2.3750	.937	1.187	1.610	.032	2.000	8.5	100,730	.895
*HCOM-24	1.5000	2.7500	1.094	1.375	1.860	.032	2.312	8.5	135,950	1.358
*HCOM-28	1.7500	3.1250	1.250	1.562	2.110	.044	2.625	8	176,370	1.948
*HCOM-32	2.0000	3.5000	1.375	1.750	2.360	.044	2.937	8.5	217,060	2.650

Bearing No.	DIMENSIONS IN MILLIMETERS							a° Misalign. Angle	Radial Static Load Capacity Newtons	Approx. Brg. Wt. Grams
	B + .038 - .013	D + .000 - .018	H ± .13	W ± .13	O Flat Dia Ref.	M Chamfer Ref.	Ball Dia. Ref.			
COM-3	4.826	14.29	5.54	7.14	7.44	.381	10.31	11	14,464	6
COM-4	6.350	16.67	6.35	8.71	9.25	.560	12.70	13.5	22,015	10
COM-5	7.938	19.05	7.14	9.53	10.64	.81	14.27	12	28,800	14
COM-6	9.525	20.64	7.92	10.31	13.11	.81	16.66	10	37,361	17
COM-7	11.113	23.02	8.71	11.10	13.46	.81	17.45	8	42,048	21
COM-8	12.700	25.40	9.91	12.70	16.26	.81	20.65	9.5	58,934	29
COM-9	14.288	27.78	11.10	14.27	18.03	.81	23.01	9.5	73,967	39
COM-10	15.875	30.16	12.70	15.88	19.81	.81	25.40	8.5	94,658	50
COM-12	19.050	36.51	15.06	19.05	23.37	1.12	30.15	9	141,982	93
COM-14	22.225	39.69	17.86	22.23	24.89	1.12	33.32	9.5	186,639	119
*COM-16	25.400	44.45	20.24	25.40	28.40	1.12	38.10	10	245,534	175
*HCOM-16	25.400	50.80	19.84	25.40	34.54	.81	42.85	9	315,010	251
*HCOM-19	30.163	60.33	23.80	30.15	40.89	.81	50.80	8.5	448,049	406
*HCOM-20	31.750	60.33	23.80	30.15	40.89	.81	50.80	8.5	448,049	406
*HCOM-24	38.100	69.85	27.79	34.93	47.24	.81	58.72	8.5	604,710	616
*HCOM-28	44.450	79.38	31.75	39.67	53.59	1.12	66.68	8	784,495	884
*HCOM-32	50.800	88.90	34.93	44.45	59.94	1.12	74.60	8.5	965,485	1,198

* Bore tolerance on these items is as follows -
INCH: +.0025, -.0005; METRIC: +.064, -.013

1 PTFE Liners use suffix T Ex: COM-10T
2 PTFE Liners have no lubrication holes or groove in race



COM-KH & HCOM-KH Series Spherical Bearings (PTFE Liners Available)¹

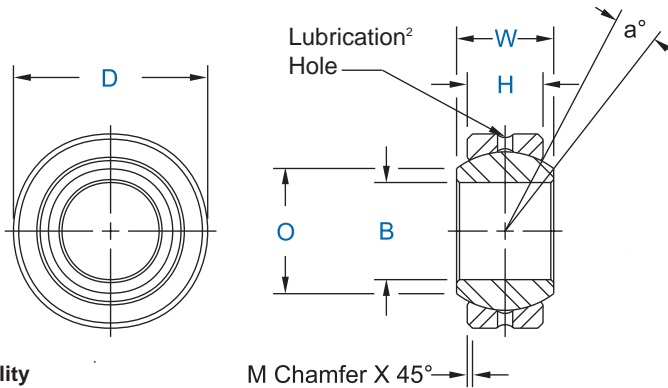

* Check for availability

Specifications	
Race	Alloy steel, heat treated, I.D. protective coated for corrosion resistance.
Ball	Alloy steel, heat treated, hard chrome plated.

Bearing No.	DIMENSIONS IN INCHES							a° Misalign. Angle	Radial Static Load Capacity Lbs.	Approx. Brg. Wt. Lbs.
	B + .0015 - .0005	D + .0000 - .0007	H ± .005	W ± .005	O Flat Dia Ref.	M Chamfer Ref.	Ball Dia. Ref.			
* COM-3KH	.1900	.5625	.218	.281	.293	.015	.406	11	4,875	.014
* COM-4KH	.2500	.6562	.250	.343	.364	.022	.500	13.5	7,425	.022
* COM-5KH	.3125	.7500	.281	.375	.419	.032	.562	12	9,713	.030
* COM-6KH	.3750	.8125	.312	.406	.516	.032	.656	10	12,600	.038
* COM-7KH	.4375	.9062	.343	.437	.530	.032	.687	8	14,180	.047
* COM-8KH	.5000	1.0000	.390	.500	.640	.032	.813	9.5	19,875	.065
* COM-9KH	.5625	1.0937	.437	.562	.710	.032	.906	9.5	24,945	.086
* COM-10KH	.6250	1.1875	.500	.625	.780	.032	1.000	8.5	31,920	.110
* COM-12KH	.7500	1.4375	.593	.750	.920	.044	1.187	9	47,880	.204
* COM-14KH	.8750	1.5625	.703	.875	.980	.044	1.312	9.5	62,940	.263
* †COM-16KH	1.0000	1.7500	.797	1.000	1.118	.044	1.500	10	82,800	.386
* †HCOM-16KH	1.0000	2.0000	.781	1.000	1.360	.032	1.687	9	106,230	.553
* †HCOM-19KH	1.1875	2.3750	.937	1.187	1.610	.032	2.000	8.5	151,095	.895
* †HCOM-20KH	1.2500	2.3750	.937	1.187	1.610	.032	2.000	8.5	151,095	.895
* †HCOM-24KH	1.5000	2.7500	1.094	1.375	1.860	.032	2.312	8.5	203,925	1.358
* †HCOM-28KH	1.7500	3.1250	1.250	1.562	2.110	.044	2.625	8	264,555	1.948
* †HCOM-32KH	2.0000	3.5000	1.375	1.750	2.360	.044	2.937	8.5	325,590	2.650

Bearing No.	DIMENSIONS IN MILLIMETERS							a° Misalign. Angle	Radial Static Load Capacity Newtons	Approx. Brg. Wt. Grams
	B + .038 - .013	D + .000 - .018	H ± .13	W ± .13	O Flat Dia Ref.	M Chamfer Ref.	Ball Dia. Ref.			
* COM-3KH	4.826	14.29	5.54	7.14	7.44	.381	10.31	11	21,701	6
* COM-4KH	6.350	16.67	6.35	8.71	9.25	.560	12.70	13.5	33,027	10
* COM-5KH	7.938	19.05	7.14	9.53	10.64	.81	14.27	12	43,206	14
* COM-6KH	9.525	20.64	7.92	10.31	13.11	.81	16.66	10	56,042	17
* COM-7KH	11.113	23.02	8.71	11.10	13.46	.81	17.45	8	63,073	21
* COM-8KH	12.700	25.40	9.91	12.70	16.26	.81	20.65	9.5	88,402	29
* COM-9KH	14.288	27.78	11.10	14.27	18.03	.81	23.01	9.5	110,956	39
* COM-10KH	15.875	30.16	12.70	15.88	19.81	.81	25.40	8.5	141,992	50
* COM-12KH	19.050	36.51	15.06	19.05	23.37	1.12	30.15	9	212,988	93
* COM-14KH	22.225	39.69	17.86	22.23	24.89	1.12	33.32	9.5	279,963	119
* †COM-16KH	25.400	44.45	20.24	25.40	28.40	1.12	38.10	10	368,306	175
* †HCOM-16KH	25.400	50.80	19.84	25.40	34.54	.81	42.85	9	472,515	251
* †HCOM-19KH	30.163	60.33	23.80	30.15	40.89	.81	50.80	8.5	672,078	406
* †HCOM-20KH	31.750	60.33	23.80	30.15	40.89	.81	50.80	8.5	672,078	406
* †HCOM-24KH	38.100	69.85	27.79	34.93	47.24	.81	58.72	8.5	907,061	616
* †HCOM-28KH	44.450	79.38	31.75	39.67	53.59	1.12	66.68	8	1,176,747	884
* †HCOM-32KH	50.800	88.90	34.93	44.45	59.94	1.12	74.60	8.5	1,448,228	1,198

† Bore tolerance on these items is as follows -
INCH: +.0025, -.0005; METRIC: +.064, -.013

¹ PTFE Liners use suffix T Ex: COM-6TKH
² PTFE Liners have no lubrication holes or groove in race



COM-E Series Spherical Bearings (PTFE Liners Available)¹

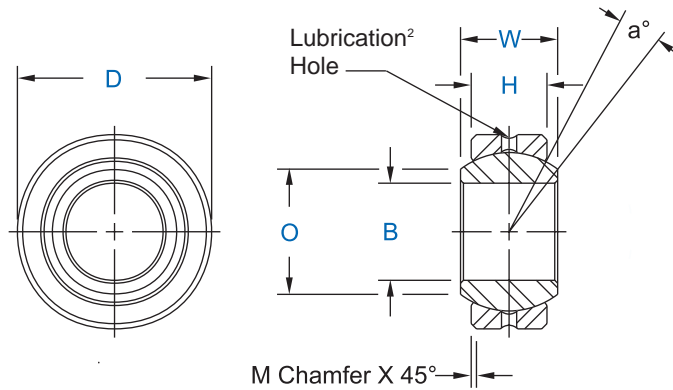

Specifications

Race - 17-4 PH stainless steel (AMS 5630), heat treated.
Ball - 440 C stainless steel (AMS 5630), heat treated, chrome plated.

THESE BEARINGS NOT NORMALLY STOCKED-
CHECK FOR AVAILABILITY.

Bearing No.	DIMENSIONS IN INCHES							a° Misalign. Angle	Radial Static Load Capacity Lbs.	Approx. Brg. Wt. Lbs.
	B + .0015 - .0005	D + .0000 - .0007	H ± .005	W ± .005	O Flat Dia Ref.	M Chamfer Ref.	Ball Dia. Ref.			
COM-3E	.1900	.5625	.218	.281	.293	.015	.406	11	4,875	.014
COM-4E	.2500	.6562	.250	.343	.364	.022	.500	13.5	7,425	.022
COM-5E	.3125	.7500	.281	.375	.419	.032	.562	12	9,713	.030
COM-6E	.3750	.8125	.312	.406	.516	.032	.625	10	12,600	.038
COM-7E	.4375	.9062	.343	.437	.530	.032	.687	8	14,180	.047
COM-8E	.5000	1.0000	.390	.500	.640	.032	.781	9.5	19,875	.065
COM-9E	.5625	1.0937	.437	.562	.710	.032	.875	9.5	24,945	.086
COM-10E	.6250	1.1875	.500	.625	.780	.032	.968	8.5	31,920	.110
COM-12E	.7500	1.4375	.593	.750	.920	.044	1.187	9	47,880	.204
COM-14E	.8750	1.5625	.703	.875	.980	.044	1.312	9.5	62,940	.263
COM-16E	1.0000	1.7500	.797	1.000	1.118	.044	1.500	10	82,800	.386

Bearing No.	DIMENSIONS IN MILLIMETERS							a° Misalign. Angle	Radial Static Load Capacity Newtons	Approx. Brg. Wt. Grams
	B + .038 - .013	D + .000 - .018	H ± .13	W ± .13	O Flat Dia Ref.	M Chamfer Ref.	Ball Dia. Ref.			
COM-3E	4.826	14.29	5.54	7.14	7.44	.381	10.31	11	21,701	6
COM-4E	6.350	16.67	6.35	8.71	9.25	.560	12.70	13.5	33,027	10
COM-5E	7.938	19.05	7.14	9.53	10.64	.81	14.27	12	43,206	14
COM-6E	9.525	20.64	7.92	10.31	13.11	.81	15.88	10	56,042	17
COM-7E	11.113	23.02	8.71	11.10	13.46	.81	17.45	8	63,073	21
COM-8E	12.700	25.40	9.91	12.70	16.26	.81	19.84	9.5	88,402	29
COM-9E	14.288	27.78	11.10	14.27	18.03	.81	22.23	9.5	110,956	39
COM-10E	15.875	30.16	12.70	15.88	19.81	.81	24.59	8.5	141,992	50
COM-12E	19.050	36.51	15.06	19.05	23.37	1.12	30.15	9	212,988	93
COM-14E	22.225	39.69	17.86	22.23	24.89	1.12	33.32	9.5	279,963	119
COM-16E	25.400	44.45	20.24	25.40	28.40	1.12	38.10	10	368,306	175

Check for availability on all sizes.

¹ PTFE Liners use suffix T Ex: COM-6ET

² PTFE Liners have no lubrication holes or groove in race



LCOM Series Large Size Spherical Bearings (PTFE Liners Available)¹

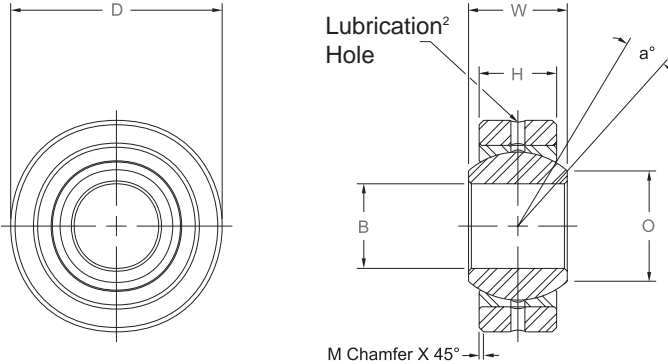

**THESE BEARINGS NOT
NORMALLY STOCKED -
CHECK FOR AVAILABILITY.**

Specifications
Outer Member - Carbon steel, protective coated for corrosion resistance.
Race - Carbon steel, I.D. protective coated for corrosion resistance.
Ball - Alloy steel, heat treated, hard chrome plated.

Bearing No.	DIMENSIONS IN INCHES							a° Misalign. Angle	Radial Static Load Capacity Lbs.	Approx. Brg. Wt. Lbs
	B + .0015 - .0005	D + .0000 - .0007	H ± .005	W ± .005	O Flat Dia Ref.	M Chamfer Ref.	Ball Dia. Ref.			
LCOM-3	.1900	.6250	.187	.281	.293	.016	.406	16	3,037	.02
LCOM-4	.2500	.7500	.281	.375	.331	.016	.500	14	5,620	.04
LCOM-5	.3125	.8750	.313	.437	.448	.016	.625	14	7,825	.05
LCOM-6	.3750	1.0000	.375	.500	.516	.016	.719	12	10,785	.08
LCOM-7	.4375	1.1875	.437	.562	.586	.032	.812	11	14,194	.12
LCOM-8	.5000	1.3125	.531	.687	.637	.044	.937	12	19,902	.18
LCOM-10	.6250	1.5625	.687	.875	.802	.044	1.187	12	32,619	.33
LCOM-12	.7500	2.2500	.937	1.250	1.038	.044	1.625	15	60,905	.97
LCOM-12-1	.7500	1.8750	.687	.875	.978	.044	1.312	10	36,054	.52
LCOM-16	1.0000	2.3750	.875	1.125	1.345	.062	1.750	10	61,250	.94
LCOM-19	1.1875	2.6250	1.000	1.250	1.562	.085	2.000	8.5	80,000	1.27
LCOM-24	1.5000	3.2500	1.250	1.500	2.000	.085	2.500	7	125,000	2.38
LCOM-30	1.8750	4.0000	1.313	1.625	2.521	.125	3.000	7	157,560	3.75

Bearing No.	DIMENSIONS IN MILLIMETERS							a° Misalign. Angle	Radial Static Load Capacity Newtons	Approx. Brg. Wt. Grams
	B + .038 - .013	D + .000 - .018	H ± .13	W ± .13	O Flat Dia Ref.	M Chamfer Ref.	Ball Dia. Ref.			
LCOM-3	4.826	15.88	4.75	7.14	7.44	.41	10.31	16	13,509	9
LCOM-4	6.350	19.05	7.14	9.53	8.41	.41	12.70	14	24,998	18
LCOM-5	7.938	22.23	7.95	11.10	11.38	.41	15.88	14	34,806	22
LCOM-6	9.525	25.40	9.53	12.70	13.11	.41	18.26	12	47,972	36
LCOM-7	11.113	30.16	11.10	14.27	14.88	.81	20.62	11	63,135	54
LCOM-8	12.700	33.34	13.49	17.45	16.18	1.12	23.80	12	88,524	82
LCOM-10	15.875	39.69	17.45	22.23	20.37	1.12	30.15	12	145,089	150
LCOM-12	19.050	57.15	23.80	31.75	26.37	1.12	41.28	15	270,905	440
LCOM-12-1	19.050	47.63	17.45	22.23	24.84	1.12	33.32	10	160,368	236
LCOM-16	25.400	60.33	22.23	28.56	34.16	1.57	44.45	10	272,440	426
LCOM-19	30.163	66.68	25.40	31.75	39.67	2.16	50.80	8.5	355,840	576
LCOM-24	38.100	82.55	31.75	38.10	50.80	2.16	63.50	7	556,000	1,080
LCOM-30	47.625	101.60	33.35	41.28	64.03	3.18	76.20	7	700,826	1,701

¹ PTFE Liners use suffix T Ex: LCOM-6T

² PTFE Liners have no lubrication holes or groove in race



AIB, SIB, MIB and MIB-T Series Spherical Bearings (PTFE Liners Available)¹

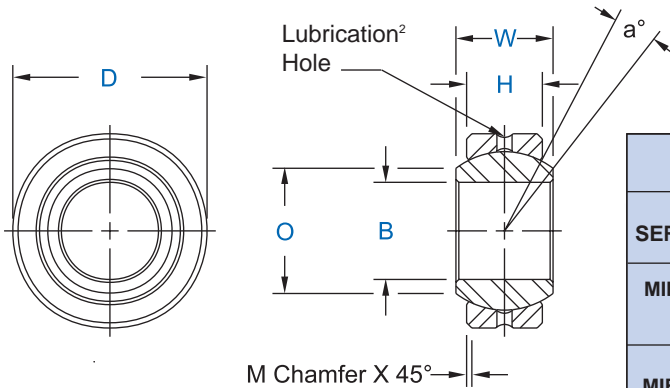

Specifications		
SERIES	BALL	RACE (OUTER MEMBER)
MIB-	Alloy steel, heat treated, hard chrome plated.	Carbon steel, I.D. protective coated for corrosion resistance, oil coated.
MIB-T ¹	Alloy steel, heat treated, hard chrome plated.	Carbon steel, PTFE Lined.
AIB-	Alloy steel, heat treated, hard chrome plated.	Alloy steel, heat treated, I.D. protective coated for corrosion resistance, oil coated.
SIB-	Alloy steel, heat treated, hard chrome plated.	Stainless steel, heat treated, oil coated.

BEARING NO.				DIMENSIONS IN INCHES							a° Misalign. Angle	Radial Static Load Capacity Lbs.		Approx. Brg. Wt. Lbs.
				B	D	H	W	O	M	Ball Dia.		MIB-MIB-T	AIB-SIB	
				+ .0015 - .0005	+ .0000 - .0007	± .005	+ .000 - .005	Flat Dia. Ref.	Chamfer Ref.	Ref.				
AIB-3	SIB-3	MIB-3	MIB-3T	.1900	.5312	.250	.312	.307	.020	.437	10.5	4,370	6,555	.016
AIB-4	SIB-4	MIB-4	MIB-4T	.2500	.6094	.281	.375	.331	.020	.500	14.5	5,620	8,430	.023
AIB-5	SIB-5	MIB-5	MIB-5T	.3125	.7500	.344	.437	.448	.020	.625	11.0	8,600	12,900	.039
AIB-6	SIB-6	MIB-6	MIB-6T	.3750	.8437	.406	.500	.516	.020	.719	9.5	11,677	17,516	.059
AIB-7	SIB-7	MIB-7	MIB-7T	.4375	1.0000	.437	.562	.587	.020	.812	11.0	14,194	21,291	.079
AIB-8	SIB-8	MIB-8	MIB-8T	.5000	1.0937	.500	.625	.699	.020	.937	9.5	18,740	28,110	.110
AIB-10	SIB-10	MIB-10	MIB-10T	.6250	1.3125	.562	.750	.839	.030	1.125	12.0	25,290	37,935	.165
AIB-12	SIB-12	MIB-12	MIB-12T	.7500	1.5000	.687	.875	.978	.030	1.312	10.0	32,448	48,672	.252
AIB-14	SIB-14	MIB-14	MIB-14T	.8750	1.6250	.750	.875	1.061	.035	1.375	6.0	39,653	58,653	.350
AIB-16*	SIB-16*	MIB-16*	MIB-16T*	1.0000	2.1250	1.000	1.375	1.275	.060	1.875	15.0	60,000	90,000	.788

BEARING NO.				DIMENSIONS IN MILLIMETERS							a° Misalign. Angle	Radial Static Load Capacity Newtons.		Approx. Brg. Wt. Grams
				B	D	H	W	O	M	Ball Dia.		MIB-MIB-T	AIB-SIB	
				+ .038 - .013	+ .000 - .013	± .13	+ .00 - .13	Flat Dia. Ref.	Chamfer Ref.	Ref.				
AIB-3	SIB-3	MIB-3	MIB-3T	4.826	13.49	6.35	7.92	7.79	.50	11.10	10.5	19,438	29,157	7.26
AIB-4	SIB-4	MIB-4	MIB-4T	6.350	15.47	7.13	9.52	8.40	.50	12.70	14.5	24,998	37,497	10.44
AIB-5	SIB-5	MIB-5	MIB-5T	7.938	19.05	8.73	11.10	11.37	.50	15.87	11.0	38,253	57,379	17.71
AIB-6	SIB-6	MIB-6	MIB-6T	9.525	21.43	10.31	12.70	13.10	.50	18.26	9.5	51,939	77,911	26.79
AIB-7	SIB-7	MIB-7	MIB-7T	11.113	25.40	11.10	14.27	14.91	.50	20.62	11.0	63,135	94,702	35.87
AIB-8	SIB-8	MIB-8	MIB-8T	12.700	27.78	12.70	15.87	17.75	.50	23.80	9.5	83,356	125,033	49.94
AIB-10	SIB-10	MIB-10	MIB-10T	15.875	33.33	14.27	19.05	21.31	.76	28.57	12.0	112,490	168,735	74.91
AIB-12	SIB-12	MIB-12	MIB-12T	19.050	38.10	17.45	22.23	24.84	.76	33.32	10.0	144,329	216,493	114.41
AIB-14	SIB-14	MIB-14	MIB-14T	22.225	41.28	19.05	22.23	26.95	.89	34.93	6.0	176,637	260,889	158.76
AIB-16*	SIB-16*	MIB-16*	MIB-16T*	25.400	53.97	25.40	34.92	32.38	1.52	47.62	15.0	266,880	400,320	357.75

¹Bore Tolerance on these items is as follows -
INCH: +.0035, -.0005; METRIC: +.089, -.013

1 PTFE Liners use suffix T Ex: AIB-6T
2 PTFE Liners have no lubrication holes or groove in race.



**GEZ..ES
OPEN**



**Spherical Plain Bearings
Inch - Open & Sealed**



**GEZ..ES-2RS
SEALED**

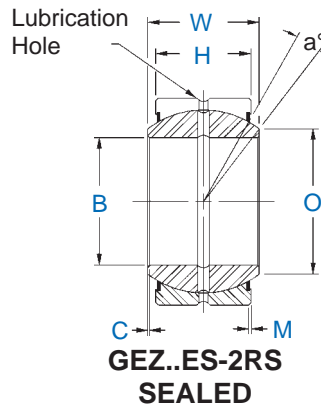
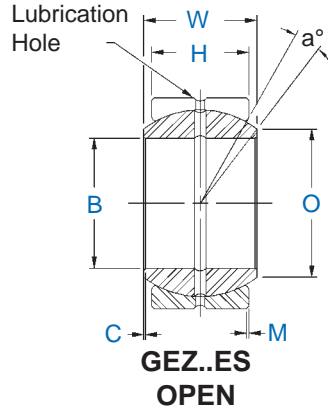
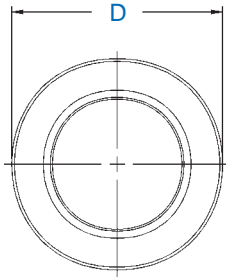

Specifications	
Race	- Alloy steel, heat treated, single fracture, phosphate coated.
Ball	- Alloy steel, heat treated, phosphate coated.

Bearing No.		DIMENSIONS IN INCHES											a° Mis-align. Angle	Radial Static Load Capacity lbs.	Approx. Brg. Wt. Lbs.
OPEN	SEALED	B Bore Dia.		D Race Dia.		W Ball Width		H Race Width		O Flat Dia.	C Ball Cmfr.	M Race Cmfr.			
		Max.	Min.	Max.	Min.	Max.	Min.	Max.	Min.	Min.	Min.	Min.			
GEZ008ES		.5000	.4995	.8750	.8745	.437	.432	.375	.365	.555	.006	.024	6	9,217	.049
GEZ010ES		.6250	.6245	1.0625	1.0620	.547	.542	.469	.459	.720	.006	.024	6	14,635	.079
GEZ012ES	GEZ012ES-2RS	.7500	.7495	1.2500	1.2495	.656	.651	.562	.552	.858	.012	.024	6	21,356	.117
GEZ014ES	GEZ014ES-2RS	.8750	.8745	1.4375	1.4370	.765	.760	.656	.646	1.000	.012	.024	6	28,550	.187
GEZ016ES	GEZ016ES-2RS	1.0000	.9995	1.6250	1.6245	.875	.870	.750	.740	1.087	.012	.024	6	37,317	.267
GEZ020ES	GEZ020ES-2RS	1.2500	1.2495	2.0000	1.9995	1.093	1.088	.937	.925	1.417	.024	.024	6	58,448	.512
GEZ022ES	GEZ022ES-2RS	1.3750	1.3745	2.1875	2.1870	1.187	1.182	1.031	1.019	1.515	.024	.039	6	69,688	.773
GEZ024ES	GEZ024ES-2RS	1.5000	1.4995	2.4375	2.4370	1.312	1.307	1.125	1.113	1.622	.024	.039	6	84,300	.930
GEZ028ES	GEZ028ES-2RS	1.7500	1.7495	2.8125	2.8120	1.531	1.526	1.312	1.300	1.996	.024	.039	6	114,648	1.413
GEZ032ES	GEZ032ES-2RS	2.0000	1.9995	3.1875	3.1869	1.750	1.745	1.500	1.484	2.280	.024	.039	6	150,616	2.055
GEZ036ES	GEZ036ES-2RS	2.2500	2.2494	3.5625	3.5619	1.969	1.963	1.687	1.671	2.555	.024	.039	6	191,080	2.932
GEZ040ES	GEZ040ES-2RS	2.5000	2.4994	3.9375	3.9369	2.187	2.181	1.875	1.859	2.886	.039	.039	6	238,288	4.079
GEZ044ES	GEZ044ES-2RS	2.7500	2.7494	4.3750	4.3744	2.406	2.400	2.062	2.046	3.114	.039	.039	6	281,000	5.335
GEZ048ES	GEZ048ES-2RS	3.0000	2.9994	4.7500	4.7493	2.625	2.619	2.250	2.230	3.417	.039	.039	6	337,200	6.834
GEZ052ES	GEZ052ES-2RS	3.2500	3.2492	5.1250	5.1243	2.844	2.836	2.437	2.417	3.720	.039	.039	6	395,648	8.422
GEZ056ES	GEZ056ES-2RS	3.5000	3.4992	5.5000	5.4993	3.062	3.054	2.625	2.605	4.000	.039	.039	6	458,595	10.560
GEZ060ES	GEZ060ES-2RS	3.7500	3.7492	5.8750	5.8743	3.281	3.273	2.812	2.792	4.280	.039	.039	6	530,528	12.743
GEZ064ES	GEZ064ES-2RS	4.0000	3.9992	6.2500	6.2490	3.500	3.492	3.000	2.980	4.559	.039	.039	6	595,720	15.410
GEZ068ES	GEZ068ES-2RS	4.2500	4.2492	6.6250	6.6240	3.719	3.711	3.187	3.167	4.835	.039	.039	6	674,400	18.541
GEZ072ES	GEZ072ES-2RS	4.5000	4.4992	7.0000	6.9990	3.937	3.929	3.375	3.355	5.142	.039	.039	6	764,320	21.583
GEZ076ES	GEZ076ES-2RS	4.7500	4.7490	7.3750	7.3738	4.156	4.148	3.562	3.542	5.417	.039	.039	6	843,000	25.353
GEZ080ES	GEZ080ES-2RS	5.0000	4.9990	7.7500	7.7488	4.375	4.365	3.750	3.730	5.720	.039	.039	6	932,920	29.762
GEZ096ES	GEZ096ES-2RS	6.0000	5.9990	8.7500	8.7488	4.750	4.740	4.125	4.105	6.622	.039	.039	5	1,168,960	38.581

RADIAL STATIC LOAD CAPACITY

These loads are the maximum safe operating loads for stationary applications, and assumes a sufficiently rigid housing and shaft. The radial static load capacity provides a 1.5 factor of safety against static fracture.

LUBRICATION

Bearings should only be used as delivered for static applications. For dynamic applications, a lithium-based grease with EP and MOS₂ additives is especially suitable. Lubricants of this type are recommended for operating temperatures between -40° F and + 250° F (-40° C and +121° C). For operating temperatures outside of this range, consult lubricant manufacturer.

Bearings should be adequately lubricated before installation, and relubricated at suitable intervals based on application demands. Demand factors include load and load direction, misalignment angle and frequency, ambient temperature and contamination level.



**GE..ES
OPEN**



**Spherical Plain Bearings
Metric - Open & Sealed**



**GE..ES-2RS
SEALED**

**M
E
T
R
I
C**

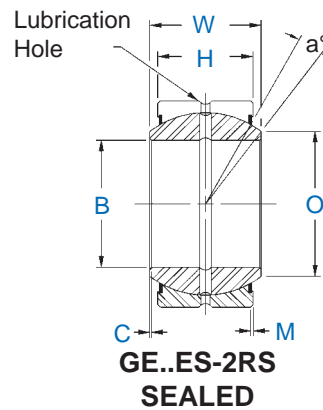
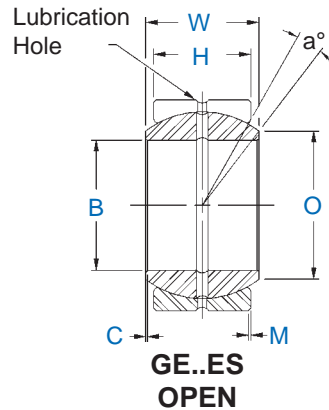
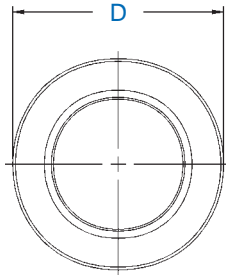

Specifications	
Race	- Alloy steel, heat treated, single fracture, phosphate coated.
Ball	- Alloy steel, heat treated, phosphate coated.

Bearing No.		DIMENSIONS IN MILLIMETERS											a° Mis-align. Angle	Radial Static Load Cap. kN	Approx. Brg. Wt. Grams
OPEN	SEALED	B Bore Dia.		D Race Dia.		W Ball Width		H Race Width		O Flat Dia.	C Ball Cmfr.	M Race Cmfr.			
		Max.	Min.	Max.	Min.	Max.	Min.	Max.	Min.	Min.	Min.	Min.			
*	GE12E	12.000	11.992	22.000	21.991	10.00	9.88	7.00	6.76	15	0.3	0.3	10	53	15
	GE15ES GE15ES-2RS	15.000	14.992	26.000	25.991	12.00	11.88	9.00	8.76	18	0.3	0.3	8	84	27
	GE17ES GE17ES-2RS	17.000	16.992	30.000	29.991	14.00	13.88	10.00	9.76	20	0.3	0.3	10	106	41
	GE20ES GE20ES-2RS	20.000	19.990	35.000	34.989	16.00	15.88	12.00	11.76	24	0.3	0.3	9	146	66
	GE25ES GE25ES-2RS	25.000	24.990	42.000	41.989	20.00	19.88	16.00	15.76	29	0.6	0.6	7	240	119
	GE30ES GE30ES-2RS	30.000	29.990	47.000	46.989	22.00	21.88	18.00	17.76	34	0.6	0.6	6	310	153
	GE35ES GE35ES-2RS	35.000	34.988	55.000	54.987	25.00	24.88	20.00	19.70	39	0.6	1.0	6	399	233
	GE40ES GE40ES-2RS	40.000	39.988	62.000	61.987	28.00	27.88	22.00	21.70	45	0.6	1.0	7	495	306
	GE45ES GE45ES-2RS	45.000	44.988	68.000	67.987	32.00	31.88	25.00	24.70	50	0.6	1.0	7	637	427
	GE50ES GE50ES-2RS	50.000	49.988	75.000	74.987	35.00	34.88	28.00	27.70	55	0.6	1.0	6	780	546
	GE60ES GE60ES-2RS	60.000	59.985	90.000	89.985	44.00	43.85	36.00	35.60	66	1.0	1.0	6	1,220	1,040
	GE70ES GE70ES-2RS	70.000	69.985	105.000	104.985	49.00	48.85	40.00	39.60	77	1.0	1.0	6	1,560	1,550
	GE80ES GE80ES-2RS	80.000	79.985	120.000	119.985	55.00	54.85	45.00	44.60	88	1.0	1.0	6	2,000	2,310
	GE90ES GE90ES-2RS	90.000	89.980	130.000	129.982	60.00	59.80	50.00	49.50	98	1.0	1.0	5	2,440	2,750
	GE100ES GE100ES-2RS	100.000	99.980	150.000	149.982	70.00	69.80	55.00	54.50	109	1.0	1.0	7	3,030	4,450
	GE110ES GE110ES-2RS	110.000	109.980	160.000	159.975	70.00	69.80	55.00	54.50	120	1.0	1.0	6	3,270	4,820
	GE120ES GE120ES-2RS	120.000	119.980	180.000	179.975	85.00	84.80	70.00	69.50	130	1.0	1.0	6	4,750	8,050
	GE140ES GE140ES-2RS	140.000	139.975	210.000	209.970	90.00	89.75	70.00	69.40	150	1.0	1.0	7	5,355	11,020
	GE160ES GE160ES-2RS	160.000	159.975	230.000	229.970	105.00	104.75	80.00	79.40	170	1.0	1.0	8	6,800	14,010

* GE-12E only available without lube grooves and holes.

RADIAL STATIC LOAD CAPACITY

These loads are the maximum safe operating loads for stationary applications, and assumes a sufficiently rigid housing and shaft. The radial static load capacity provides a 1.5 factor of safety against static fracture.

LUBRICATION

Bearings should only be used as delivered for static applications. For dynamic applications, a lithium-based grease with EP and MOS₂ additives is especially suitable. Lubricants of this type are recommended for operating temperatures between -40° F and +250° F (-40° C and +121° C). For operating temperatures outside of this range, consult lubricant manufacturer.

Bearings should be adequately lubricated before installation, and relubricated at suitable intervals based on application demands. Demand factors include load and load direction, misalignment angle and frequency, ambient temperature and contamination level.



Spherical Plain Bearings Inch - Sealed PTFE Lined



**GEZ..ET-2RS
SEALED**

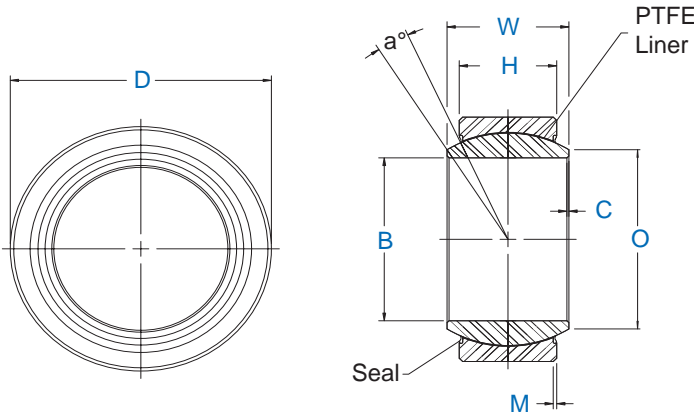

Specifications	
Race	- Alloy steel, heat treated, single fracture, PTFE lined.
Ball	- Alloy steel, heat treated, hard chrome plated.

Bearing No.	DIMENSIONS IN INCHES											a° Misalign. Angle	Radial Static Load Capacity lbs.	Approx. Brg. Wt. Lbs.
	B Bore Dia.		D Race Dia.		W Ball Width		H Race Width		O Flat Dia.	C Ball Cmfr.	M Race Cmfr.			
SEALED	Max.	Min.	Max.	Min.	Max.	Min.	Max.	Min.	Min.	Min.	Min.			
GEZ012ET-2RS	.7500	.7495	1.2500	1.2495	.656	.651	.562	.552	.858	.012	.024	6	20,682	.117
GEZ014ET-2RS	.8750	.8745	1.4375	1.4370	.765	.760	.656	.646	1.000	.012	.024	6	27,875	.187
GEZ016ET-2RS	1.0000	.9995	1.6250	1.6245	.875	.870	.750	.740	1.087	.012	.024	6	36,642	.267
GEZ020ET-2RS	1.2500	1.2495	2.0000	1.9995	1.093	1.088	.937	.925	1.417	.024	.024	6	58,898	.512
GEZ022ET-2RS	1.3750	1.3745	2.1875	2.1870	1.187	1.182	1.031	1.019	1.515	.024	.039	6	69,688	.773
GEZ024ET-2RS	1.5000	1.4995	2.4375	2.4370	1.312	1.307	1.125	1.113	1.622	.024	.039	6	82,277	.930
GEZ028ET-2RS	1.7500	1.7495	2.8125	2.8120	1.531	1.526	1.312	1.300	1.996	.024	.039	6	115,772	1.413
GEZ032ET-2RS	2.0000	1.9995	3.1875	3.1869	1.750	1.745	1.500	1.484	2.280	.024	.039	6	150,616	2.055
GEZ036ET-2RS	2.2500	2.2494	3.5625	3.5619	1.969	1.963	1.687	1.671	2.555	.024	.039	6	191,080	2.932
GEZ040ET-2RS	2.5000	2.4994	3.9375	3.9369	2.187	2.181	1.875	1.859	2.886	.039	.039	6	238,288	4.079
GEZ044ET-2RS	2.7500	2.7494	4.3750	4.3744	2.406	2.400	2.062	2.046	3.114	.039	.039	6	284,822	5.335
GEZ048ET-2RS	3.0000	2.9994	4.7500	4.7493	2.625	2.619	2.250	2.230	3.417	.039	.039	6	340,347	6.834
GEZ052ET-2RS	3.2500	3.2492	5.1250	5.1243	2.844	2.836	2.437	2.417	3.720	.039	.039	6	400,144	8.422
GEZ056ET-2RS	3.5000	3.4992	5.5000	5.4993	3.062	3.054	2.625	2.605	4.000	.039	.039	6	464,212	10.560
GEZ060ET-2RS	3.7500	3.7492	5.8750	5.8743	3.281	3.273	2.812	2.792	4.280	.039	.039	6	532,326	12.743
GEZ064ET-2RS	4.0000	3.9992	6.2500	6.2490	3.500	3.492	3.000	2.980	4.559	.039	.039	6	604,712	15.410
GEZ068ET-2RS	4.2500	4.2492	6.6250	6.6240	3.719	3.711	3.187	3.167	4.835	.039	.039	6	681,144	18.541
GEZ072ET-2RS	4.5000	4.4992	7.0000	6.9990	3.937	3.929	3.375	3.355	5.142	.039	.039	6	764,320	21.583
GEZ076ET-2RS	4.7500	4.7490	7.3750	7.3738	4.156	4.148	3.562	3.542	5.417	.039	.039	6	851,992	25.353
GEZ080ET-2RS	5.0000	4.9990	7.7500	7.7488	4.375	4.365	3.750	3.730	5.720	.039	.039	6	946,408	29.762
GEZ096ET-2RS	6.0000	5.9990	8.7500	8.7488	4.750	4.740	4.125	4.105	6.622	.039	.039	5	1,777,952	38.581

RADIAL STATIC LOAD CAPACITY

These loads are the maximum safe operating loads for stationary applications, and assumes a sufficiently rigid housing and shaft. The radial static load capacity provides a 1.5 factor of safety against static fracture.

LUBRICATION

Self lubricating PTFE liner.



Spherical Plain Bearings Metric - Sealed PTFE Lined



**GE..ET-2RS
SEALED**

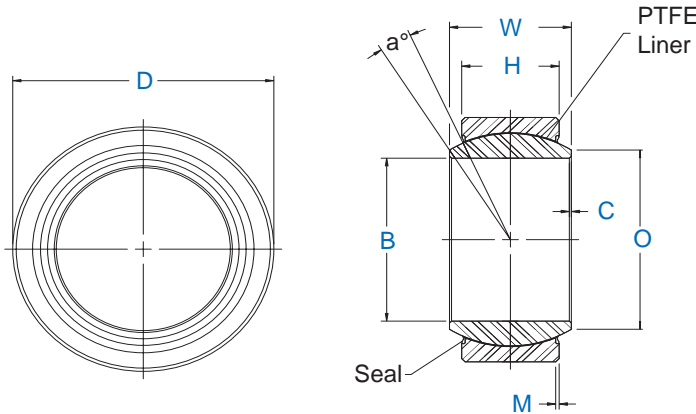

Specifications
Race - Alloy steel, heat treated, single fracture, PTFE lined.
Ball - Alloy steel, heat treated, hard chrome plated.

Bearing No.	DIMENSIONS IN MILLIMETERS											a° Mis-align. Angle	Radial Static Load Cap. kN	Approx. Brg. Wt. Grams
	B Bore Dia.		D Race Dia.		W Ball Width		H Race Width		O Flat Dia.	C Ball Cmfr.	M Race Cmfr.			
SEALED	Max.	Min.	Max.	Min.	Max.	Min.	Max.	Min.	Min.	Min.	Min.			
GE15ET-2RS	15.000	14.992	26.000	25.991	12.00	11.88	9.00	8.76	18	0.3	0.3	8	47	27
GE17ET-2RS	17.000	16.992	30.000	29.991	14.00	13.88	10.00	9.76	20	0.3	0.3	10	60	41
GE20ET-2RS	20.000	19.990	35.000	34.989	16.00	15.88	12.00	11.76	24	0.3	0.3	9	83	66
GE25ET-2RS	25.000	24.990	42.000	41.989	20.00	19.88	16.00	15.76	29	0.6	0.6	7	137	119
GE30ET-2RS	30.000	29.990	47.000	46.989	22.00	21.88	18.00	17.76	34	0.6	0.6	6	176	153
GE35ET-2RS	35.000	34.988	55.000	54.987	25.00	24.88	20.00	19.70	39	0.6	1.0	6	224	233
GE40ET-2RS	40.000	39.988	62.000	61.987	28.00	27.88	22.00	21.70	45	0.6	1.0	7	280	306
GE45ET-2RS	45.000	44.988	68.000	67.987	32.00	31.88	25.00	24.70	50	0.6	1.0	7	360	427
GE50ET-2RS	50.000	49.988	75.000	74.987	35.00	34.88	28.00	27.70	55	0.6	1.0	6	440	546
GE60ET-2RS	60.000	59.985	90.000	89.985	44.00	43.85	36.00	35.60	66	1.0	1.0	6	695	1,040
GE70ET-2RS	70.000	69.985	105.000	104.985	49.00	48.85	40.00	39.60	77	1.0	1.0	6	880	1,550
GE80ET-2RS	80.000	79.985	120.000	119.985	55.00	54.85	45.00	44.60	88	1.0	1.0	6	1,140	2,310
GE90ET-2RS	90.000	89.980	130.000	129.982	60.00	59.80	50.00	49.50	98	1.0	1.0	5	1,370	2,750
GE100ET-2RS	100.000	99.980	150.000	149.982	70.00	69.80	55.00	54.50	109	1.0	1.0	7	1,730	4,450
GE110ET-2RS	110.000	109.980	160.000	159.975	70.00	69.80	55.00	54.50	120	1.0	1.0	6	1,860	4,820
GE120ET-2RS	120.000	119.980	180.000	179.975	85.00	84.80	70.00	69.50	130	1.0	1.0	6	2,700	8,050
* GE140ET-2RS	140.000	139.975	210.000	209.970	90.00	89.75	70.00	69.40	150	1.0	1.0	7	3,000	11,020
* GE160ET-2RS	160.000	159.975	230.000	229.970	105.00	104.75	80.00	79.40	170	1.0	1.0	8	3,800	14,010

*Parts 140 mm and above have a double fracture race.

RADIAL STATIC LOAD CAPACITY

These loads are the maximum safe operating loads for stationary applications, and assumes a sufficiently rigid housing and shaft. The radial static load capacity provides a 1.5 factor of safety against static fracture.

LUBRICATION

Self lubricating PTFE liner.

Tables are representative of Metal to Metal parts, please consult our engineering department regarding PTFE lined parts.

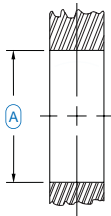

Suggested Housing Bores Spherical Plain Bearings

Bearing Series GE..ES GE..ES..2RS	DIMENSIONS IN INCHES									
	A Suggested Housing Bore For Press Fit of Spherical Plain Bearings									
	Bearing Outside Diameter		ISO H7		ISO M7		ISO N7		Extra Heavy Press Fit	
	Max.	Min.	Max.	Min.	Max.	Min.	Max.	Min.	Max.	Min.
008	.8750	.8745	.8758	.8750	.8750	.8742	.8747	.8739	.8743	.8735
010	1.0625	1.0625	1.0633	1.0625	1.0625	1.0617	1.0622	1.0614	1.0610	1.0620
012	1.2500	1.2495	1.2510	1.2500	1.2500	1.2490	1.2497	1.2487	1.2485	1.2475
014	1.4375	1.4370	1.4385	1.4375	1.4375	1.4365	1.4372	1.4362	1.4360	1.4350
016	1.6250	1.6245	1.6260	1.6250	1.6250	1.6240	1.6247	1.6237	1.6235	1.6225
020	2.0000	1.9995	2.0012	2.0000	2.0000	1.9988	1.9996	1.9985	1.9987	1.9975
022	2.1875	2.1870	2.1887	2.1875	2.1875	2.1863	2.1871	2.1860	2.1862	2.1850
024	2.4375	2.4370	2.4387	2.4375	2.4375	2.4363	2.4371	2.4360	2.4362	2.4350
028	2.8125	2.8120	2.8137	2.8125	2.8125	2.8113	2.8210	2.8110	2.8112	2.8100
032	3.1875	3.1869	3.1889	3.1875	3.1875	3.1861	3.1871	3.1857	3.1859	3.1845
036	3.5625	3.5619	3.5639	3.5625	3.5625	3.5611	3.5621	3.5607	3.5604	3.5590
040	3.9375	3.9369	3.9389	3.9375	3.9375	3.9361	3.9357	3.9371	3.9354	3.9340
044	4.3750	4.3744	4.3764	4.3750	4.3750	4.3736	4.3746	4.3732	4.3729	4.3715
048	4.7500	4.7493	4.7516	4.7500	4.7500	4.7484	4.7495	4.7418	4.7476	4.7460
052	5.1250	5.1243	5.1266	5.1250	5.1250	5.1234	5.1245	5.1230	5.1226	5.1210
056	5.5000	5.4993	5.5016	5.5000	5.5000	5.4984	5.4995	5.4980	5.4976	5.4960
060	5.8750	5.8743	5.8766	5.8750	5.8750	5.8734	5.8745	5.8730	5.8726	5.8710
064	6.2500	6.2490	6.2516	6.2500	6.2500	6.2484	6.2495	6.2480	6.2476	6.2460
068	6.6250	6.6240	6.6266	6.6250	6.6250	6.6234	6.6245	6.6230	6.6226	6.6210
072	7.0000	6.9990	7.0016	7.0000	7.0000	6.9984	6.9995	6.9980	6.9976	6.9960
076	7.3750	7.3740	7.3768	7.3750	7.3750	7.3732	7.3744	7.3726	7.3728	7.3710
080	7.7500	7.7490	7.7518	7.7500	7.7500	7.7482	7.7494	7.7476	7.7478	7.7460
096	8.7500	8.7490	8.7518	8.7500	8.7500	8.7482	8.7494	8.7476	8.7478	8.7460

Bearing Series GE..ES GE..ES..2RS	DIMENSIONS IN MILLIMETERS									
	A Suggested Housing Bore For Press Fit of Spherical Plain Bearings									
	Bearing Outside Diameter		ISO H7		ISO M7		ISO N7		Extra Heavy Press Fit	
	Max.	Min.	Max.	Min.	Max.	Min.	Max.	Min.	Max.	Min.
12	22.000	21.991	22.021	22.000	22.000	21.979	21.993	21.972	21.982	21.962
15	26.000	25.991	26.021	26.000	26.000	25.979	25.993	25.972	25.962	25.937
17	30.000	29.991	30.021	30.000	30.000	29.979	29.993	29.972	29.962	29.937
20	35.000	34.989	35.025	35.000	35.000	34.975	34.992	34.967	34.962	34.937
25	42.000	41.989	42.025	42.000	42.000	41.975	41.992	41.967	41.967	41.937
30	47.000	46.989	42.025	47.000	47.000	46.975	46.992	46.967	46.967	46.937
35	55.000	54.987	55.030	55.000	55.000	54.970	54.991	54.961	54.967	54.937
40	62.000	61.987	62.030	62.000	62.000	61.970	61.991	61.961	61.967	61.937
45	68.000	67.987	68.030	68.000	68.000	67.970	67.991	67.961	67.967	67.937
50	75.000	74.987	75.030	75.000	75.000	74.970	74.991	74.961	74.967	74.937
60	90.000	89.985	90.035	90.000	90.000	89.965	89.990	89.955	89.967	89.911
70	105.000	104.985	105.035	105.000	105.000	104.965	104.990	104.955	104.967	104.911
80	120.000	119.985	120.035	120.000	120.000	119.965	119.990	119.955	119.967	119.911
90	130.000	129.982	130.040	130.000	130.000	129.960	129.988	129.948	129.939	129.898
100	150.000	149.982	150.040	150.000	150.000	149.960	149.988	149.948	149.939	149.898
110	160.000	159.975	160.040	160.000	160.000	159.960	159.988	159.948	159.939	159.898
120	180.000	179.975	180.040	180.000	180.000	179.960	179.988	179.948	179.939	179.898
140	210.000	209.970	210.046	210.000	210.000	209.954	209.949	209.940	209.995	209.898
160	230.000	229.970	230.046	230.000	230.000	229.954	229.949	229.940	229.995	229.898

ISO H7 - Fit recommended for light loads where axial displacement is required after installation.

ISO M7 - Press fit where bearing is subjected to combination, reversing, or shock loads.

ISO N7 - Recommended fit when using a light alloy housing (i.e. aluminum).

EXTRA HEAVY PRESS FIT - Recommended fit for applications with extreme shock loads that can also tolerate elevated breakaway torques. A sufficiently rigid housing is assumed.

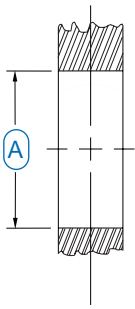

Suggested Housing Bores COM, HCOM, MIB, AIB & SIB Spherical Bearings

COM & HCOM Series

Bearing Series COM HCOM	DIMENSIONS IN INCHES				
	A Suggested Housing Bore For Press Fit of Spherical Bearings				
	Bearing Outside Diameter +.0000 -.0007	Steel Housing		Aluminum Housing	
Max.		Min.	Max.	Min.	
3	.5625	.5619	.5614	.5618	.5612
4	.6562	.6556	.6551	.6555	.6549
5	.7500	.7494	.7489	.7493	.7487
6	.8125	.8119	.8114	.8118	.8112
7	.9062	.9056	.9051	.9055	.9049
8	1.0000	.9994	.9989	.9993	.9987
9	1.0937	1.0931	1.0925	1.0930	1.0923
10	1.1875	1.1869	1.1863	1.1868	1.1861
12	1.4375	1.4369	1.4363	1.4368	1.4361
14	1.5625	1.5619	1.5613	1.5618	1.5611
16	1.7500	1.7494	1.7486	1.7493	1.7485
16	2.0000	1.9994	1.9986	1.9993	1.9985
19	2.3750	2.3744	2.3736	2.3743	2.3735
20	2.3750	2.3744	2.3736	2.3743	2.3735
24	2.7500	2.7494	2.7486	2.7493	2.7485
28	3.1250	3.1244	3.1236	3.1243	3.1235
32	3.5000	3.4994	3.4986	3.4993	3.4985

Bearing Series COM HCOM	DIMENSIONS IN MILLIMETERS				
	A Suggested Housing Bore For Press Fit of Spherical Bearings				
	Bearing Outside Diameter +.000 -.018	Steel Housing		Aluminum Housing	
Max.		Min.	Max.	Min.	
3	14.288	14.272	14.260	14.270	14.255
4	16.667	16.652	16.640	16.650	16.634
5	19.050	19.035	19.022	19.032	19.017
6	20.638	20.622	20.610	20.620	20.604
7	23.018	23.002	22.990	23.000	22.985
8	25.400	25.385	25.372	25.382	25.367
9	27.780	27.765	27.750	27.762	27.744
10	30.162	30.147	30.132	30.145	30.127
12	36.512	36.497	36.482	36.495	36.477
14	39.688	39.672	39.657	39.670	39.652
16	44.450	44.435	44.414	44.432	44.412
16	50.800	50.785	50.764	50.782	50.762
19	60.325	60.310	60.289	60.307	60.287
20	60.325	60.310	60.289	60.307	60.287
24	69.850	69.835	69.814	69.832	69.812
28	79.375	79.360	79.339	79.357	79.337
32	88.900	88.885	88.864	88.882	88.862

Dimensions given in the above tables are for bearings fabricated of standard race materials. Should other materials be used, consult our engineering department for modification of these dimensions.

RADIAL STATIC LOAD CAPACITY

These loads are maximum static based on maximum permanent set in the bearing race of 0.2% of the ball diameter. If a greater permanent set can be allowed or if alternate race materials are used consult our engineering department for change factors.

AXIAL STATIC LOAD CAPACITY

These loads are approximately 20% of the radial loads listed when the load bearing surfaces are properly supported.

ALTERNATE RACE AND BALL MATERIALS

Materials other than those listed can be incorporated in bearings manufactured by Aurora Bearing Company. Stainless steels to improve corrosion resistance, heat treated alloy steels to increase wear life are frequently used in special applications.

PTFE lined races are also available in this series to provide service requiring no relubrication and improved frictional characteristics. **Tables are representative of Metal to Metal parts, please consult our engineering department regarding PTFE lined parts.**

MIB, AIB & SIB Series

Bearing Series MIB AIB SIB	DIMENSIONS IN INCHES				
	A Suggested Housing Bore For Press Fit of Spherical Bearings				
	Bearing Outside Diameter +.0000 -.0007	Steel Housing		Aluminum Housing	
Max.		Min.	Max.	Min.	
3	.5312	.5306	.5301	.5305	.5299
4	.6094	.6088	.6083	.6087	.6081
5	.7500	.7494	.7489	.7493	.7487
6	.8437	.8431	.8426	.8430	.8424
7	1.0000	.9994	.9989	.9993	.9987
8	1.0937	1.0931	1.0925	1.0930	1.0923
10	1.3125	1.3119	1.3113	1.3118	1.3111
12	1.5000	1.4994	1.4988	1.4993	1.4986
14	1.6250	1.6244	1.6236	1.6243	1.6235
16	2.1250	2.1244	2.1236	2.1243	2.1235

Bearing Series MIB AIB SIB	DIMENSIONS IN MILLIMETERS				
	A Suggested Housing Bore For Press Fit of Spherical Bearings				
	Bearing Outside Diameter +.000 -.018	Steel Housing		Aluminum Housing	
Max.		Min.	Max.	Min.	
3	13.492	13.477	13.465	13.475	13.460
4	15.479	15.464	15.451	15.461	15.446
5	19.050	19.035	19.022	19.032	19.017
6	21.430	21.415	21.402	21.412	21.397
7	25.400	25.385	25.372	25.382	25.367
8	27.780	27.765	27.750	27.762	27.744
10	33.338	33.322	33.307	33.320	33.302
12	38.100	38.085	38.070	38.082	38.064
14	41.275	41.259	41.239	41.257	41.237
16	53.975	53.960	53.939	53.957	53.937



Suggested Housing Bores LCOM & COM-M Spherical Bearings

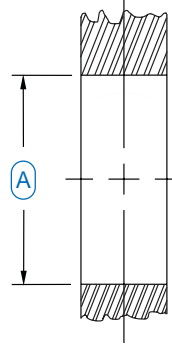

LCOM Series

COM-M Series

Bearing Series LCOM	DIMENSIONS IN INCHES				
	Ⓐ Suggested Housing Bore For Press Fit of Spherical Bearings				
	Bearing Outside Diameter +.0000 -.0007	Steel Housing		Aluminum Housing	
Max.		Min.	Max.	Min.	
3	.6250	.6244	.6239	.6243	.6237
4	.7500	.7494	.7489	.7493	.7487
5	.8750	.8744	.8739	.8743	.8737
6	1.0000	.9994	.9989	.9993	.9987
7	1.1875	1.1869	1.1863	1.1868	1.1861
8	1.3125	1.3119	1.3113	1.3118	1.3111
10	1.5625	1.5619	1.5613	1.5618	1.5611
12	2.2500	2.2494	2.2486	2.2493	2.2485
12-1	1.8750	1.8744	1.8736	1.8743	1.8735
16	2.3750	2.3744	2.3736	2.3743	2.3735
19	2.6250	2.6244	2.6236	2.6243	2.6235
24	3.2500	3.2494	3.2486	3.2493	3.2485
30	4.0000	3.9994	3.9986	3.9993	3.9985

Bearing Series COM-M	DIMENSIONS IN MILLIMETERS				
	Ⓐ Suggested Housing Bore For Press Fit of Metric Spherical Bearings				
	Bearing Outside Diameter + .000 - .018	Steel Housing		Aluminum Housing	
Max.		Min.	Max.	Min.	
3	12	11.985	11.972	11.982	11.967
5	16	15.985	15.972	15.982	15.967
6	18	17.985	17.972	17.982	17.967
8	22	21.985	21.972	21.982	21.967
10	26	25.985	25.972	25.982	25.967
12	30	29.985	29.969	29.982	29.964
14	34	33.985	33.969	33.982	33.964
16	38	37.985	37.969	37.982	37.964
18	42	41.985	41.969	41.982	41.964
20	46	45.985	45.964	45.982	45.962
22	50	49.985	49.964	49.982	49.962
25	56	55.985	55.964	55.982	55.962
30	66	65.985	65.964	65.982	65.962

Bearing Series LCOM	DIMENSIONS IN MILLIMETERS				
	Ⓐ Suggested Housing Bore For Press Fit of Spherical Bearings				
	Bearing Outside Diameter + .000 - .018	Steel Housing		Aluminum Housing	
Max.		Min.	Max.	Min.	
3	15.875	15.860	15.847	15.857	15.842
4	19.050	19.035	19.022	19.032	19.017
5	22.225	22.210	22.197	22.207	22.192
6	25.400	25.385	25.372	25.382	25.367
7	30.163	30.148	30.132	30.145	30.127
8	33.338	33.323	33.307	33.320	33.302
10	39.688	39.673	39.657	39.670	39.652
12	57.150	57.135	57.114	57.132	57.112
12-1	47.625	47.610	47.589	47.607	47.587
16	60.325	60.310	60.289	60.307	60.287
19	66.675	66.660	66.639	66.657	66.637
24	82.550	82.535	82.514	82.532	82.512
30	101.600	101.585	101.564	101.582	101.562

Bearing Series COM-M	DIMENSIONS IN INCHES				
	Ⓐ Suggested Housing Bore For Press Fit of Metric Spherical Bearings				
	Bearing Outside Diameter + .0000 - .0007	Steel Housing		Aluminum Housing	
Max.		Min.	Max.	Min.	
3	.4724	.4718	.4713	.4717	.4711
5	.6299	.6293	.6288	.6292	.6286
6	.7087	.7081	.7076	.7080	.7074
8	.8661	.8655	.8650	.8654	.8648
10	1.0236	1.0230	1.0225	1.0229	1.0223
12	1.1811	1.1805	1.1799	1.1804	1.1797
14	1.3386	1.3380	1.3374	1.3379	1.3372
16	1.4961	1.4955	1.4949	1.4954	1.4947
18	1.6535	1.6529	1.6523	1.6528	1.6521
20	1.8110	1.8104	1.8096	1.8103	1.8095
22	1.9685	1.9679	1.9671	1.9678	1.9670
25	2.2047	2.2041	2.2033	2.2040	2.2032
30	2.5984	2.5978	2.5970	2.5977	2.5969

These tables are representative of Metal to Metal parts, please consult our engineering department regarding PTFE lined parts.



HB Series
Ball Bearing, Self-aligning Rod Ends

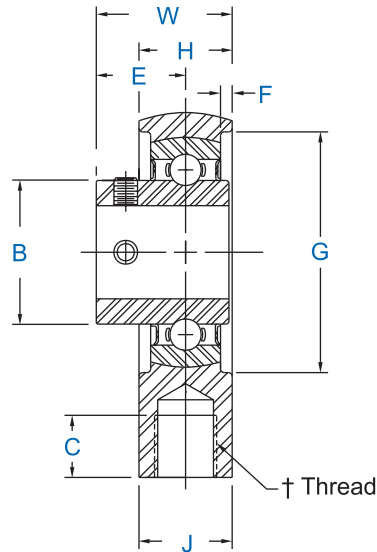
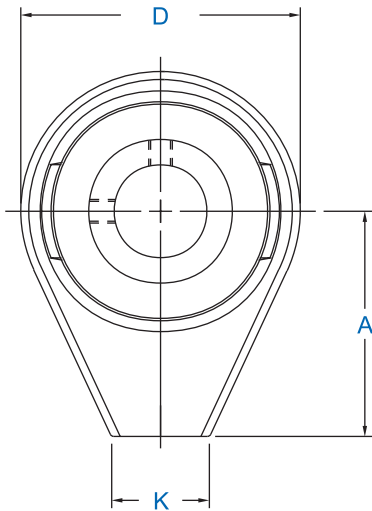

**HOUSING MATERIAL -
DUCTILE IRON**

Shaft Dia.	Unit No.	DIMENSIONS IN INCHES											Thread Size	Approx. Wt. Lbs.	
		A	B Ref.	C	D	E	F	G	H	J	K	W			
1/2"	HB-8														
5/8"	HB-10	1 3/4	.961	5/8	2 1/16	5/8	7/64	1 11/16	11/16	11/16	3/4	31/32	1/2-20 UNF	.625	
* 11/16"	HB-11														
3/4"	HB-12	1 13/16	1.165	1/2	2 1/4	23/32	3/32	1 15/16	3/4	3/4	13/16	1 3/32	1/2-13 UNC	.750	
* 7/8"	HB-14														
* 15/16"	HB-15	2 1/8	1.335	3/4	2 5/8	49/64	7/64	2 11/64	13/16	15/16	15/16	1 11/64	5/8-11 UNC		
* 1"	HB-16														

Consult our Engineering Department for load ratings and RPM information.

Shaft Dia.	Unit No.	DIMENSIONS IN MILLIMETERS											Thread Size	Approx. Wt. Lbs.
		A	B Ref.	C	D	E	F	G	H	J	K	W		
1/2"	HB-8													
5/8"	HB-10	44.45	24.41	15.88	52.37	15.88	2.78	42.86	17.46	17.46	19.05	24.61	1/2-20 UNF	284
* 11/16"	HB-11													
3/4"	HB-12	46.04	29.59	12.70	57.15	18.26	2.38	49.21	19.05	19.05	20.64	27.78	1/2-13 UNC	341
* 7/8"	HB-14													
* 15/16"	HB-15	53.98	33.91	19.05	66.68	19.45	2.78	55.17	20.64	23.81	23.81	29.77	5/8-11 UNC	
* 1"	HB-16													

*Check for availability.

† Threaded rods can be supplied to your specs.



XM & XB Series Male Rod Ends

Extra Strength - Heavy Duty Shank (PTFE Liners Available)

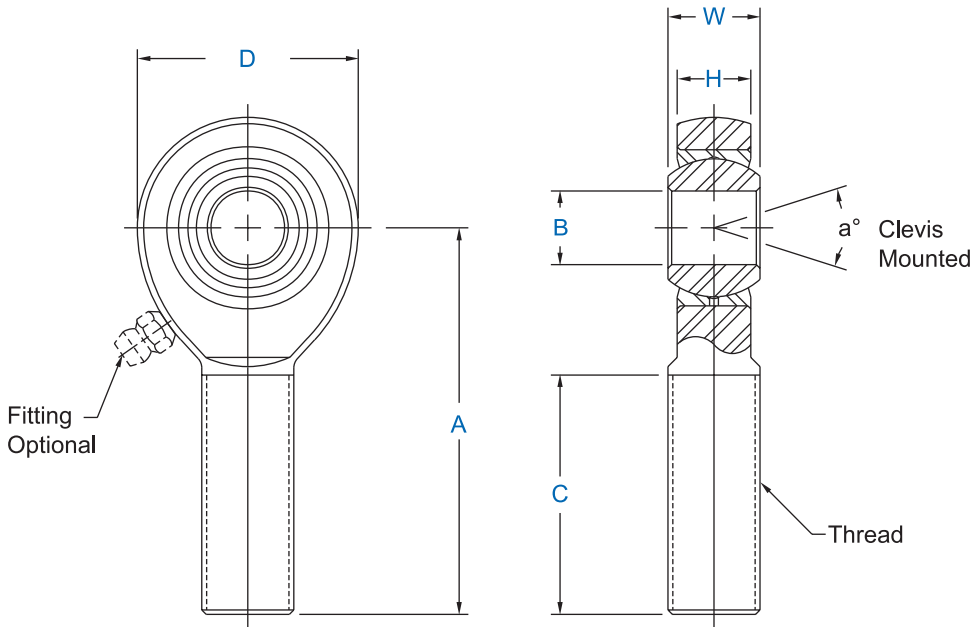

Specifications
Body - Carbon steel protective coated for corrosion resistance.
Race - Alloy steel, heat treated protective coated for corrosion resistance. (Carbon steel with PTFE liners.)
Ball - Alloy steel, heat treated, hard chrome plated.
Notes
All sizes available with studs upon request. All sizes sold solid shank type.

Rod End No.		DIMENSIONS IN INCHES								a° Misalign. Angle	Ultimate Radial Static Load Capacity Lbs.	Approx. Brg. Wt. Lbs.
Right Hand	Left Hand	B + .0015 - .0005	W + .000 - .005	H ± .005	A ± .015	D ± .010	Ball Dia. Ref.	C + .062 - .031	Thread UNF-3A			
XM-3	XB-3	.1900	.312	.250	1.562	.750	.437	1.000	1/4-28	10	2,158	.043
XM-4	XB-4	.2500	.375	.281	1.875	.875	.500	1.250	5/16-24	13	3,467	.072
XM-5	XB-5	.3125	.437	.344	1.938	1.000	.625	1.250	3/8-24	12	5,323	.112
XM-6	XB-6	.3750	.500	.406	2.125	1.125	.719	1.375	7/16-20	10	7,180	.160
XM-7	XB-7	.4375	.562	.437	2.438	1.312	.812	1.500	1/2-20	12	9,620	.249
XM-8	XB-8	.5000	.625	.500	2.625	1.500	.937	1.625	5/8-18	10	12,807	.382
XM-10	XB-10	.6250	.750	.562	2.875	1.750	1.125	1.750	3/4-16	13	16,565	.602
XM-12	XB-12	.7500	.875	.687	3.375	2.000	1.312	1.875	7/8-14	12	22,803	.918
XM-12-1	XB-12-1	.7500	.875	.687	3.375	2.000	1.312	1.875	3/4-16	12	22,803	.918
XM-14-1	XB-14-1	.8750	.875	.687	3.375	2.000	1.312	1.875	7/8-14	12	22,803	.918

Rod End No.		DIMENSIONS IN MILLIMETERS								a° Misalign. Angle	Ultimate Radial Static Load Capacity Newtons	Approx. Brg. Wt. Grams
Right Hand	Left Hand	B + .038 - .013	W + .00 - .13	H ± .13	A ± .38	D ± .25	Ball Dia. Ref.	C + 1.57 - .79	Thread UNF-3A			
XM-3	XB-3	4.826	7.92	6.35	39.67	19.05	11.10	25.40	1/4-28	10	9,600	20
XM-4	XB-4	6.350	9.53	7.14	47.63	22.23	12.70	31.75	5/16-24	13	15,425	33
XM-5	XB-5	7.938	11.10	8.74	49.23	25.40	15.88	31.75	3/8-24	12	23,682	51
XM-6	XB-6	9.525	12.70	10.31	53.98	28.58	18.26	34.93	7/16-20	10	31,938	73
XM-7	XB-7	11.113	14.27	11.10	61.93	33.32	20.62	38.10	1/2-20	12	42,794	113
XM-8	XB-8	12.700	15.88	12.70	66.68	38.10	23.80	41.28	5/8-18	10	56,963	173
XM-10	XB-10	15.875	19.05	14.27	73.02	44.45	28.58	44.45	3/4-16	13	73,683	273
XM-12	XB-12	19.050	22.23	17.45	85.73	50.80	33.32	47.63	7/8-14	12	101,424	427
XM-12-1	XB-12-1	19.050	22.23	17.45	85.73	50.80	33.32	47.63	3/4-16	12	101,424	427
XM-14-1	XB-14-1	22.225	22.23	17.45	85.73	50.80	33.32	47.63	7/8-14	12	101,424	427

Load ratings apply only to rod ends without grease fittings. For load ratings with fittings, please consult our engineering department.

Units are supplied without grease fittings. When a grease fitting is required, specify by adding suffix as designated.

- Z Zerk type fitting Ex: XM-6Z
- F Flush type fitting Ex: XM-6F
- T PTFE Liner Ex: XM-6T



XAM & XAB Series Male Rod Ends

High Strength Alloy - Heavy Duty Shank (PTFE Liners Available)

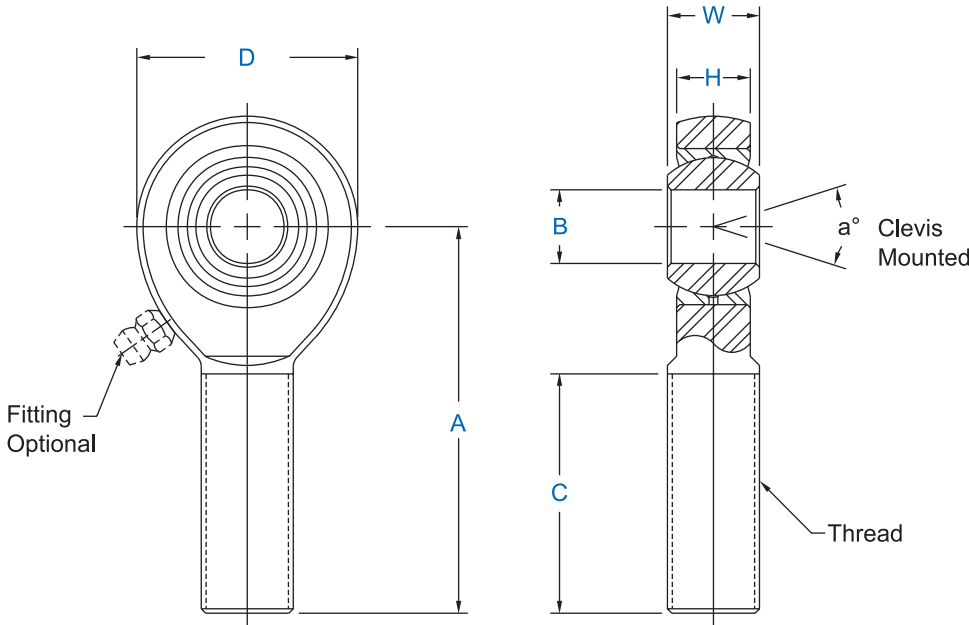

Specifications
Body - Alloy steel, heat treated, protective coated for corrosion resistance.
Race - Alloy steel, heat treated protective coated for corrosion resistance. (Carbon steel with PTFE liners.)
Ball - Alloy steel, heat treated, hard chrome plated.
Notes
All sizes available with studs upon request. All sizes sold solid shank type.

Rod End No.		DIMENSIONS IN INCHES								a° Misalign. Angle	Ultimate Radial Static Load Capacity Lbs.	Approx. Brg. Wt. Lbs.
Right Hand	Left Hand	B + .0015 - .0005	W + .000 - .005	H ± .005	A ± .015	D ± .010	Ball Dia. Ref.	C + .062 - .031	Thread UNF-3A			
XAM-3	XAB-3	.1900	.312	.250	1.562	.750	.437	1.000	1/4-28	10	5,260	.043
XAM-4	XAB-4	.2500	.375	.281	1.875	.875	.500	1.250	5/16-24	13	8,452	.072
XAM-5	XAB-5	.3125	.437	.344	1.938	1.000	.625	1.250	3/8-24	12	12,978	.112
XAM-6	XAB-6	.3750	.500	.406	2.125	1.125	.719	1.375	7/16-20	10	17,508	.160
XAM-7	XAB-7	.4375	.562	.437	2.438	1.312	.812	1.500	1/2-20	12	23,452	.249
XAM-8	XAB-8	.5000	.625	.500	2.625	1.500	.937	1.625	5/8-18	10	31,390	.382
XAM-10	XAB-10	.6250	.750	.562	2.875	1.750	1.125	1.750	3/4-16	13	40,572	.602
XAM-12	XAB-12	.7500	.875	.687	3.375	2.000	1.312	1.875	7/8-14	12	55,692	.918
1	XAM-16	XAB-16	1.000	1.375	1.000	4.125	2.750	1.875	1 1/4-12	17	76,200	2.406
* 2	XAM-20-1	XAB-20-1	1.250	1.093	.937	4.125	2.750	1.795	1 1/2-12	7	79,728	2.625
* 2	XAM-24-1	XAB-24-1	1.500	1.312	1.125	5.375	3.500	2.155	1 3/4-12	6.5	138,826	6.062

Rod End No.		DIMENSIONS IN MILLIMETERS								a° Misalign. Angle	Ultimate Radial Static Load Capacity Newtons	Approx. Brg. Wt. Grams
Right Hand	Left Hand	B + .038 - .013	W + .00 - .13	H ± .13	A ± .38	D ± .25	Ball Dia. Ref.	C + 1.57 - .79	Thread UNF-3A			
XAM-3	XAB-3	4.826	7.92	6.35	39.67	19.05	11.10	25.40	1/4-28	10	23,397	20
XAM-4	XAB-4	6.350	9.53	7.14	47.63	22.23	12.70	31.75	5/16-24	13	37,596	33
XAM-5	XAB-5	7.938	11.10	8.74	49.23	25.40	15.88	31.75	3/8-24	12	57,728	51
XAM-6	XAB-6	9.525	12.70	10.31	53.98	28.58	18.26	34.93	7/16-20	10	77,880	73
XAM-7	XAB-7	11.113	14.27	11.10	61.93	33.32	20.62	38.10	1/2-20	12	104,317	113
XAM-8	XAB-8	12.700	15.88	12.70	66.68	38.10	23.80	41.28	5/8-18	10	139,628	173
XAM-10	XAB-10	15.875	19.05	14.27	73.02	44.45	28.58	44.45	3/4-16	13	180,461	273
XAM-12	XAB-12	19.050	22.23	17.45	85.73	50.80	33.32	47.63	7/8-14	12	247,721	427
3	XAM-16	XAB-16	25.400	34.93	25.40	104.78	68.85	47.63	1 1/4-12	17	338,937	1,091
* 4	XAM-20-1	XAB-20-1	31.750	27.76	23.80	104.78	68.85	45.59	1 1/2-12	7	354,636	1,191
* 4	XAM-24-1	XAB-24-1	38.100	33.32	28.58	136.53	88.90	54.74	1 3/4-12	6.5	617,497	2,750

- 1 Tolerance variation: "B" +.0035, -.0005; "A" ±.020; "D" ±.020; "H" ±.010 Same as AM-16.
 - 2 Tolerance variation: "B" +.0000, -.0005; "A" ±.020; "D" ±.020; "H" ±.010 Check for availability.
 - 3 Tolerance variation: "B" +.089, -.013; "A" ±.51; "D" ±.51; "H" ±.25 Check for availability.
 - 4 Tolerance variation: "B" +.000, -.013; "A" ±.51; "D" ±.51; "H" ±.25 Check for availability.
- * Consult factory for PTFE lined part dimensions.

Units are supplied without grease fittings. When a grease fitting is required, specify by adding suffix as designated.
 Z Zerk type fitting Ex: XAM-6Z
 F Flush type fitting Ex: XAM-6F
 T PTFE Liner Ex: XAM-6T
 Load ratings apply only to rod ends without grease fittings. For load ratings with fittings, please consult our engineering department.



RAM, RAB, RXAM, RXAB Series Male Rod Ends

High Strength Alloy (PTFE Liners Available)

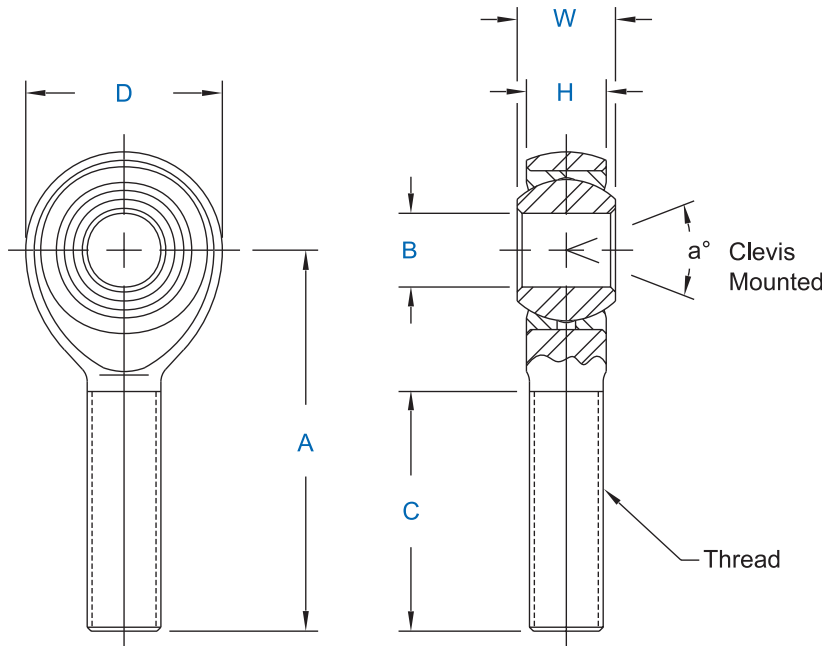

Specifications
Body - Alloy steel, heat treated, nickel or chrome plated.
Race - Alloy steel, heat treated, nickel plated.
Ball - Alloy steel, heat treated, hard chrome plated.

RAM - Heavy Duty

Rod End No.		DIMENSIONS IN INCHES								a° Misalign. Angle	Ultimate Radial Static Load Capacity Lbs.	Approx. Brg. Wt. Lbs.
Right Hand	Left Hand	B + .0015 - .0005	W + .000 - .005	H ± .005	A ± .010	D + .000 - .020	Ball Dia. Ref.	C + .062 - .031	Thread UNJF-3A			
RAM-3	RAB-3	.1900	.312	.250	1.250	.625	.437	.750	10-32 ¹	13	2,851	.028
RAM-4	RAB-4	.2500	.375	.281	1.562	.750	.500	1.000	1/4-28	16	5,260	.043
RAM-5	RAB-5	.3125	.437	.344	1.875	.875	.625	1.187	5/16-24	14	7,125	.072
RAM-6	RAB-6	.3750	.500	.406	1.938	1.000	.719	1.187	3/8-24	12	8,939	.112
RAM-7	RAB-7	.4375	.562	.437	2.125	1.125	.812	1.312	7/16-20	14	9,653	.160
RAM-8	RAB-8	.5000	.625	.500	2.438	1.312	.937	1.437	1/2-20	12	15,500	.249
RAM-10	RAB-10	.6250	.750	.562	2.625	1.500	1.125	1.562	5/8-18	16	17,148	.382
* RAM-10-12	RAB-10-12	.6250	.875	.687	2.875	1.750	1.312	1.687	3/4-16	14	27,021	.602
RAM-12	RAB-12	.7500	.875	.687	2.875	1.750	1.312	1.687	3/4-16	14	27,021	.602

RXAM - Extra Heavy Duty

Rod End No.		DIMENSIONS IN INCHES								a° Misalign. Angle	Ultimate Radial Static Load Capacity Lbs.	Approx. Brg. Wt. Lbs.
Right Hand	Left Hand	B + .0015 - .0005	W + .000 - .005	H ± .005	A ± .010	D + .000 - .020	Ball Dia. Ref.	C + .062 - .031	Thread UNJF-3A			
RXAM-3	RXAB-3	.1900	.312	.250	1.562	.750	.437	1.000	1/4-28	10	5,260	.043
RXAM-4	RXAB-4	.2500	.375	.281	1.875	.875	.500	1.187	5/16-24	13	8,452	.072
RXAM-5	RXAB-5	.3125	.437	.344	1.938	1.000	.625	1.187	3/8-24	12	12,978	.112
RXAM-6	RXAB-6	.3750	.500	.406	2.125	1.125	.719	1.312	7/16-20	10	17,508	.160
RXAM-7	RXAB-7	.4375	.562	.437	2.438	1.312	.812	1.437	1/2-20	12	22,760	.249
RXAM-8	RXAB-8	.5000	.625	.500	2.625	1.500	.937	1.562	5/8-18	10	30,579	.382
RXAM-10	RXAB-10	.6250	.750	.562	2.875	1.750	1.125	1.687	3/4-16	13	39,674	.602

* Check for availability
1 Threads UNF-3A

PTFE Liners use suffix T Ex: RAM-10T



High Misalignment Series Male Rod Ends & Spherical Bearings

Specifications
Body - 4340 steel, heat treated, protective coated for corrosion resistance.
Race - 4130 steel, heat treated, protective coated for corrosion resistance.
Ball - 52100 steel (AMS 7440), heat treated, hard chrome plated.
PTFE liner - (AT 3200) Permanently bonded to race inside diameter. Qualified to SAE-AS81820 (formerly MIL-B-81820).

HXAM-T

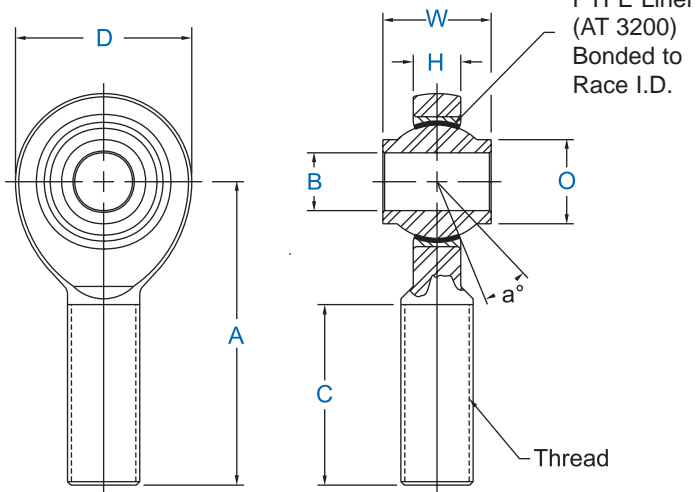

HAB-T

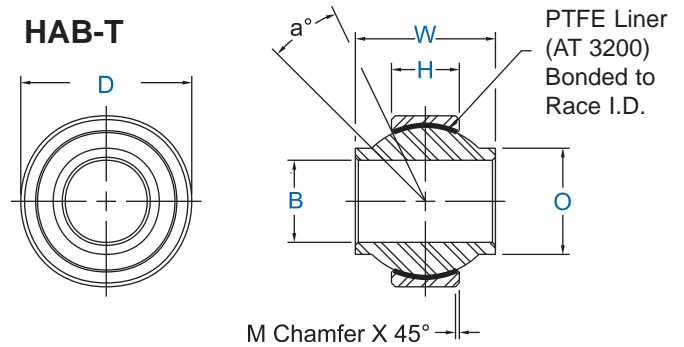

HXAM-T

Rod End No.		DIMENSIONS IN INCHES									a° Misalign. Angle	Ultimate Radial Static Load Capacity Lbs.	Approx. Brg. Wt. Lbs.
Right Hand	Left Hand	B +.0000 -.0005	W +.000 -.005	H ±.005	A ±.010	D ±.010	Ball Dia. Ref.	C ±.031	Thread UNJF-3A	O Shoulder Dia.			
HXAM-4T	HXAB-4T	.2500	.593	.265	1.938	1.025	.593	1.187	3/8-24	.390	23	10,789	.12
HXAM-5T	HXAB-5T	.3125	.813	.355	2.125	1.150	.781	1.281	7/16-20	.512	22	11,781	.16
HXAM-6T	HXAB-6T	.3750	.813	.355	2.125	1.150	.781	1.281	7/16-20	.512	22	11,781	.15
HXAM-7T	HXAB-7T	.4375	.875	.355	2.438	1.337	.875	1.468	1/2-20	.618	21	17,105	.24
HXAM-8T	HXAB-8T	.5000	.937	.411	2.625	1.525	1.000	1.562	5/8-18	.730	19	23,720	.39
HXAM-10T	HXAB-10T	.6250	1.200	.577	2.875	1.775	1.250	1.687	3/4-16	.856	19	32,067	.60
HXAM-12T	HXAB-12T	.7500	1.280	.630	3.375	2.025	1.375	2.000	7/8-14	.970	18	38,660	.89

HAB-T

Bearing No.	DIMENSIONS IN INCHES							a° Misalign. Angle	Ultimate Radial Static Load Capacity Lbs.	Approx. Brg. Wt. Lbs.
Plain Series	B +.0000 -.0005	D +.0000 -.0005	W +.000 -.005	H ±.005	M Ref.	O Ref.	Ball Dia. Ref.			
HAB-4T	.2500	.7400	.593	.255	.020	.390	.593	24	7,560	.036
HAB-5T	.3125	.9060	.813	.345	.030	.512	.781	23	16,975	.078
HAB-6T	.3750	.9060	.813	.345	.030	.512	.781	23	16,975	.070
HAB-7T	.4375	1.0000	.875	.345	.030	.618	.875	22	19,018	.091
HAB-8T	.5000	1.1250	.937	.401	.030	.730	1.000	20	25,263	.132
HAB-10T	.6250	1.3750	1.200	.567	.030	.856	1.250	20	44,651	.254
HAB-12T	.7500	1.5625	1.280	.620	.035	.970	1.375	18	53,707	.332
HAB-14T	.8750	1.7500	1.400	.630	.039	1.140	1.531	18	72,424	.436

For Staking Groove add suffix G as required Ex: HAB-6TG. Check for availability.



Performance Racing Series
PRM-T & PRXM-T Series Male Rod Ends - PTFE Lined

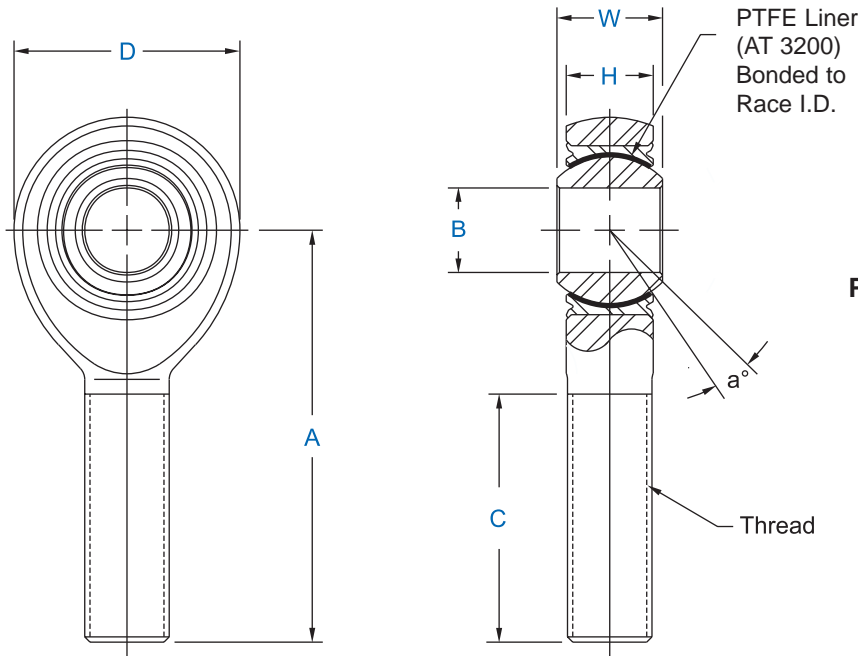

PRM-T

PRXM-T

Specifications	
Body - 4340 steel, heat treated, protective coated for corrosion resistance.	
Race - Stainless steel (17-4 PH per AMS 5643), heat treated.	
Ball - 52100 steel (AMS 7440), heat treated, hard chrome plated.	
PTFE Liner - (AT 3200) Permanently bonded to race inside diameter. Qualified to SAE-AS81820 (formerly MIL-B-81820).	

PRM-T - Performance Racing Series

Rod End No.		DIMENSIONS IN INCHES								a° Misalign. Angle	Ultimate Radial Static Load Capacity Lbs.	No Load Rotational Breakaway Torque In-Lbs.
Right Hand	Left Hand	B +.0000 -.0005	W +.000 -.005	H ± .005	A ± .010	D ± .010	Ball Dia. Ref.	C ± .031	Thread UNJF-3A			
PRM-5T	PRB-5T	.3125	.437	.327	1.875	.900	.593	1.187	5/16-24	14	8,300	1 - 15
PRM-6T	PRB-6T	.3750	.500	.416	1.938	1.025	.687	1.187	3/8-24	8	10,946	1 - 15
PRM-7T	PRB-7T	.4375	.562	.452	2.125	1.150	.781	1.281	7/16-20	10	14,049	1 - 15
PRM-8T	PRB-8T	.5000	.625	.515	2.438	1.337	.875	1.468	1/2-20	9	23,310	1 - 15
PRM-10T	PRB-10T	.6250	.750	.577	2.625	1.525	1.062	1.562	5/8-18	12	25,909	1 - 15
PRM-12T	PRB-12T	.7500	.875	.640	2.875	1.775	1.250	1.687	3/4-16	13	34,319	1 - 15

PRXM-T - Performance Racing - Heavy Duty Shank Series

Rod End No.		DIMENSIONS IN INCHES								a° Misalign. Angle	Ultimate Radial Static Load Capacity Lbs.	No Load Rotational Breakaway Torque In-Lbs.
Right Hand	Left Hand	B +.0000 -.0005	W +.000 -.005	H ± .005	A ± .010	D ± .010	Ball Dia. Ref.	C ± .031	Thread UNJF-3A			
PRXM-4T	PRXB-4T	.2500	.375	.337	1.562	.806	.531	.968	5/16-24	6	7,544	.5 - 6
PRXM-5T	PRXB-5T	.3125	.437	.327	1.875	.900	.593	1.187	3/8-24	14	9,135	1 - 15
PRXM-6T	PRXB-6T	.3750	.500	.416	1.938	1.025	.687	1.187	7/16-20	8	10,946	1 - 15
PRXM-7T	PRXB-7T	.4375	.562	.452	2.125	1.150	.781	1.281	1/2-20	10	14,049	1 - 15
PRXM-8T	PRXB-8T	.5000	.625	.515	2.438	1.337	.875	1.468	5/8-18	9	23,310	1 - 15
PRXM-10T	PRXB-10T	.6250	.750	.577	2.625	1.525	1.062	1.562	3/4-16	12	25,909	1 - 15



Performance Racing Series
PNB-TG & PNB-T Series, PWB-TG & PWB-T Series
Spherical Bearings - PTFE Lined

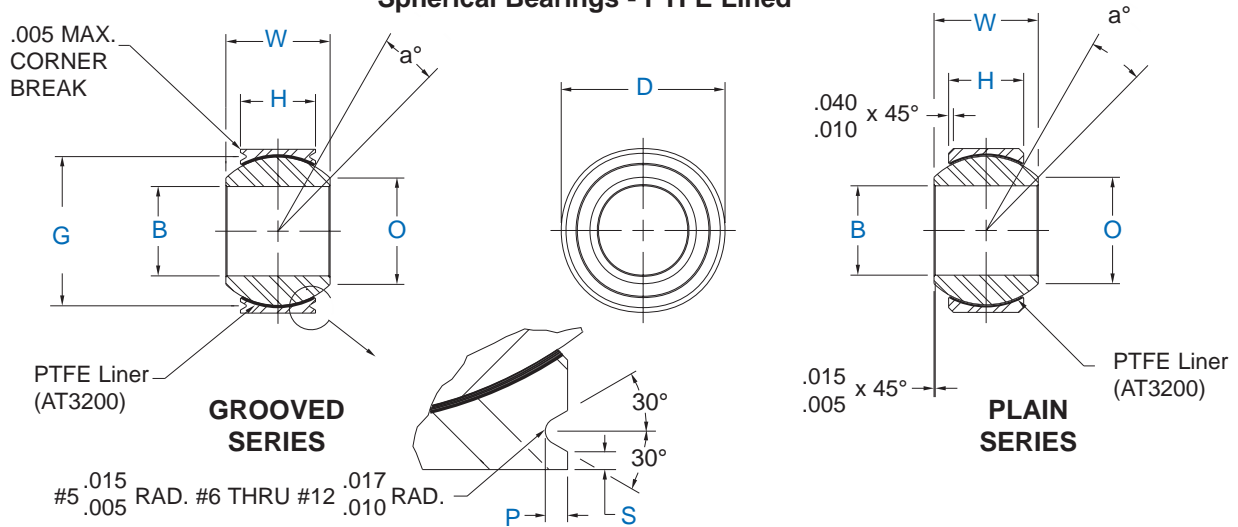

Specifications		
BALL - Alloy steel, heat treated, hard chrome plated.	RACE - Stainless Steel (17-4PH per AMS 5643), heat treated PTFE Lined.	PTFE LINER - (AT 3200) Permanently bonded to race inside diameter. Qualified to SAE-AS81820 (formerly MIL-B-81820).

PNB-TG & PNB-T - Performance Racing Spherical Narrow Series

Rod End No.		DIMENSIONS IN INCHES										a°	Static Limit Load		No Load Rotational Breakaway Torque in-Lbs.
Grooved	Plain	B +.0000 -.0005	D +.0000 -.0005	W ±.005	H ±.005	O Min.	P +.000 -.010	S Min.	G +.000 -.008	Ball Dia. Ref.	Radial Lbs.		Axial Lbs.		
PNB-5TG	PNB-5T	.3125	.7500	.375	.281	.419	.035	.020	.650	.562	10	8,750	700	0.25 - 8.0	
PNB-6TG	PNB-6T	.3750	.8125	.406	.312	.475	.035	.020	.712	.625	9	10,540	1,100	0.25 - 8.0	
PNB-7TG	PNB-7T	.4375	.9062	.437	.343	.530	.035	.020	.806	.687	8	13,200	1,400	0.25 - 8.0	
PNB-8TG	PNB-8T	.5000	1.0000	.500	.390	.600	.055	.020	.876	.781	8	17,900	2,100	0.25 - 8.0	
* PNB-9TG	PNB-9T	.5625	1.0937	.562	.437	.670	.060	.020	.972	.875	8	23,200	3,680	0.25 - 8.0	
PNB-10TG	PNB-10T	.6250	1.1875	.625	.500	.739	.055	.020	1.063	.968	8	30,500	4,720	0.25 - 8.0	
PNB-12TG	PNB-12T	.7500	1.4375	.750	.593	.920	.055	.020	1.313	1.187	8	46,400	6,750	0.25 - 8.0	

PWB-TG & PWB-T - Performance Racing Spherical Wide Series

Rod End No.		DIMENSIONS IN INCHES										a°	Static Limit Load		No Load Rotational Breakaway Torque in-Lbs.
Grooved	Plain	B +.0000 -.0005	D +.0000 -.0005	W ±.005	H ±.005	O Min.	P +.000 -.010	S Min.	G +.000 -.008	Ball Dia. Ref.	Radial Lbs.		Axial Lbs.		
PWB-5TG	PWB-5T	.3125	.6875	.437	.317	.401	.025	.010	.625	.593	14	9,400	1,640	0.25 - 8.0	
PWB-6TG	PWB-6T	.3750	.8125	.500	.406	.466	.035	.020	.712	.687	8	13,700	2,630	0.25 - 8.0	
PWB-7TG	PWB-7T	.4375	.9375	.562	.442	.537	.035	.020	.837	.781	10	20,700	3,650	0.25 - 8.0	
PWB-8TG	PWB-8T	.5000	1.0000	.625	.505	.607	.035	.020	.900	.875	9	21,400	4,970	0.25 - 8.0	
PWB-9TG	PWB-9T	.5625	1.1250	.687	.536	.721	.040	.020	1.027	1.000	10	26,600	5,370	0.25 - 8.0	
PWB-10TG	PWB-10T	.6250	1.1875	.750	.567	.747	.035	.020	1.087	1.062	12	29,000	6,130	0.25 - 8.0	
PWB-12TG	PWB-12T	.7500	1.3750	.875	.630	.887	.055	.020	1.251	1.250	13	37,000	7,730	0.25 - 8.0	

* Check for availability



**ALM, ALB, XALM & XALB Series
Male Rod Ends
(PTFE Liners Available)**

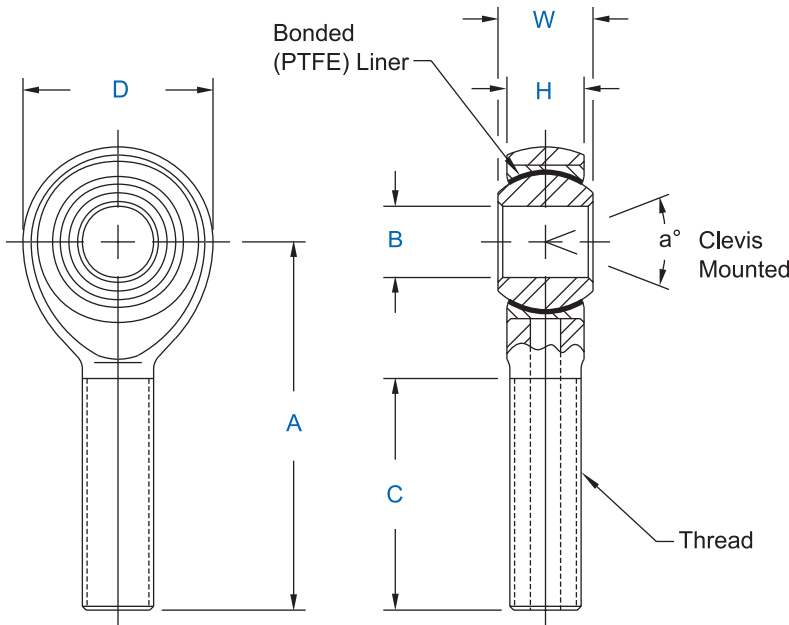

Specifications	
Body - Aluminum 7075-T651, hard anodized.	
Race - Carbon steel, protective coated for corrosion resistance.	
Ball - Alloy steel, heat treated, hard chrome plated.	

ALM - Aluminum Series

Rod End No.		DIMENSIONS IN INCHES								a° Misalign. Angle	Ultimate Radial Static Load Capacity Lbs.	Approx. Brg. Wt. Lbs.
Right Hand	Left Hand	B + .0015 - .0005	W + .000 - .005	H ± .005	A ± .015	D ± .010	Ball Dia. Ref.	C + .062 - .031	Thread UNF-3A			
ALM-8	ALB-8	.5000	.625	.500	2.438	1.250	.875	1.437	1/2-20*	13	7,596	.140
ALM-10	ALB-10	.6250	.750	.562	2.625	1.500	1.125	1.625	5/8-18	16	8,516	.240
ALM-12	ALB-12	.7500	.875	.687	2.875	1.750	1.312	1.750	3/4-16	14	13,319	.380

XALM - Aluminum Series

Rod End No.		DIMENSIONS IN INCHES								a° Misalign. Angle	Ultimate Radial Static Load Capacity Lbs.	Approx. Brg. Wt. Lbs.
Right Hand	Left Hand	B + .0015 - .0005	W + .000 - .005	H ± .005	A ± .015	D ± .010	Ball Dia. Ref.	C + .062 - .031	Thread UNF-3A			
XALM-8	XALB-8	.5000	.625	.500	2.625	1.500	.937	1.625	5/8-20	10	14,889	.200
XALM-10	XALB-10	.6250	.750	.562	2.875	1.750	1.125	1.750	3/4-16	13	19,243	.310

* Threads are 1/2-20 UNJF-3A.

PTFE Liners use suffix T Ex: XALM-8T



MILITARY SPECIFICATION BEARINGS

General Information

Aurora Bearing Company's reputation for designing and producing high quality commercial rod ends and spherical bearings has grown extensively since the inception of the organization. Aurora Bearing has rapidly expanded its various product lines and now serves virtually every major industrial market.

In all of these markets, Aurora Bearing has consistently demonstrated its reputation for furnishing a reliable product. As a result, more and more firms sought help from our engineers and manufacturing specialists to solve difficult applications problems in high performance equipment. For example, Aurora Bearing was a pioneer in developing a special line of rod ends for the high temperature turbine engine industry.

Because of the special skills developed by our engineering and manufacturing personnel in the commercial bearing markets, our recognized expertise attracted the attention of the military specification bearing market, which includes the aircraft/aerospace industry. Frequently, our engineers have been called upon to develop custom-designed units for sophisticated aero-

space applications. In some instances, our standard commercial series of commercial rod ends and spherical bearings were more than adequate for aircraft/aerospace usage.

Consequently, Aurora Bearing Company decided to aggressively enter the military specification bearing marketplace. We now offer six standard lines that are presented in the following pages. Please note that the bearings listed utilize AT 3200, Aurora's exclusive PTFE bearing liner fully qualified to SAE-AS81820 (formerly MIL-B-81820). The bearings are manufactured to conform to the dimensions, materials and configurations of the appropriate individual military bearing specification. They are fully qualified and approved for procurement under these specifications. In addition, Aurora also has two standard lines of bearings in the general aviation field. Consult Aurora Bearing engineering for additional information.

Sales engineers specializing in the aviation field are available to discuss your particular application needs.





ASM-T & ASB-T Male Rod Ends
High Strength - Aerospace Series
SAE-AS81935/1 (Right Hand) & SAE-AS81935/1 (Left Hand)

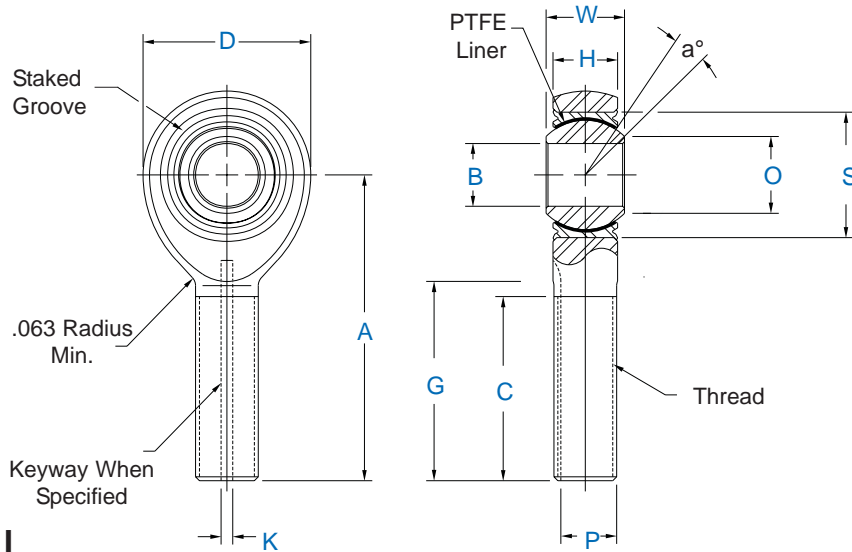

TABLE I

Rod End No.		DIMENSIONS IN INCHES													a°	Approx.
Right Hand	Left Hand	B +.0000 -.0005	W +.000 -.002	H ± .005	A ± .010	D ± .010	O Min.	S Max. Housing I.D.	Ball Dia. Ref.	G +.000 -.020	K +.005 -.000	P +.000 -.005	C ± .031	Thread UNJF-3A	Misalign. Angle Min.	Brg. Wt. Lbs.
ASM-3T	ASB-3T	.1900	.437	.337	1.562	.806	.300	.6250	.531	.980	.062	.268	.968	5/16-24	15	.072
ASM-4T	ASB-4T	.2500	.437	.337	1.562	.806	.300	.6250	.531	.980	.062	.268	.968	5/16-24	15	.072
ASM-5T	ASB-5T	.3125	.437	.327	1.875	.900	.360	.6875	.593	1.270	.062	.268	1.187	5/16-24	14	.087
ASM-6T	ASB-6T	.3750	.500	.416	1.938	1.025	.470	.8125	.687	1.235	.093	.319	1.187	3/8-24	8	.136
ASM-7T	ASB-7T	.4375	.562	.452	2.125	1.150	.540	.9062	.781	1.402	.093	.383	1.281	7/16-20	10	.183
ASM-8T	ASB-8T	.5000	.625	.515	2.438	1.337	.610	1.0000	.875	1.589	.093	.445	1.468	1/2-20	9	.278
ASM-10T	ASB-10T	.6250	.750	.577	2.625	1.525	.750	1.1875	1.062	1.683	.125	.541	1.562	5/8-18	12	.424
ASM-12T	ASB-12T	.7500	.875	.640	2.875	1.775	.850	1.3750	1.250	1.808	.125	.663	1.687	3/4-16	13	.639
ASM-14T	ASB-14T	.8750	.875	.765	3.375	2.025	1.000	1.6250	1.375	2.121	.156	.777	2.000	7/8-14	6	.963
ASM-16T	ASB-16T	1.0000	1.375	1.015	4.125	2.775	1.270	2.1250	1.875	2.464	.187	1.136	2.343	1 1/4-12	12	2.546

Specifications	
BODY	4340 Alloy Steel (MIL-S-5000) Heat Treated Cadmium Plated
BALL	440C Stainless Steel (AMS 5630) Heat Treated Hard Chrome Plated
RACE	17-4 PH Stainless Steel (AMS 5643) Heat Treated
LINER	AT 3200 Bearing Liner, Permanently Bonded to Race I.D. Qualified to SAE-AS81820

Temperature Range: -65°F to + 325°F

*No load rotational breakaway torque can be varied to meet specific application requirements.

Add Letter "K" to prefix to designate keyway, Ex. : ASMK-6T.

As applicable, keyway will conform to SAE-AS81935/3 or NAS 559.

All threads are rolled after heat treatment, and conform to

UNJF-3A per MIL-S-8879.

AT 3200 Bearing Liner System is qualified for procurement under SAE-AS81820.

Rod End Bearings listed are manufactured to conform to the dimensions, materials and configurations of SAE-AS81935/1, and are approved for procurement under this specification. Consult factory for additional information.

TABLE II

Rod End No.		Ultimate Radial Static Load Lbs.	Fatigue Load Lbs.	Axial Proof Load Lbs.	No Load Rotational Breakaway Torque* In-Lbs.	
Right Hand	Left Hand				Min.	Max.
ASM-3T	ASB-3T	2,360	1,470	1,000	.5	6
ASM-4T	ASB-4T	4,860	2,380	1,000	.5	6
ASM-5T	ASB-5T	7,180	2,770	1,100	1	15
ASM-6T	ASB-6T	8,550	3,570	1,660	1	15
ASM-7T	ASB-7T	12,000	4,800	1,850	1	15
ASM-8T	ASB-8T	19,500	7,680	2,040	1	15
ASM-10T	ASB-10T	21,900	9,180	2,430	1	15
ASM-12T	ASB-12T	29,300	11,600	2,810	1	15
ASM-14T	ASB-14T	34,500	13,100	3,320	1	24
ASM-16T	ASB-16T	80,300	30,400	4,340	1	24

**THESE BEARINGS NOT NORMALLY STOCKED
CHECK FOR AVAILABILITY.**



ASW-T & ASG-T Female Rod Ends
High Strength - Aerospace Series
SAE-AS81935/2 (Right Hand) & SAE-AS81935/2 (Left Hand)

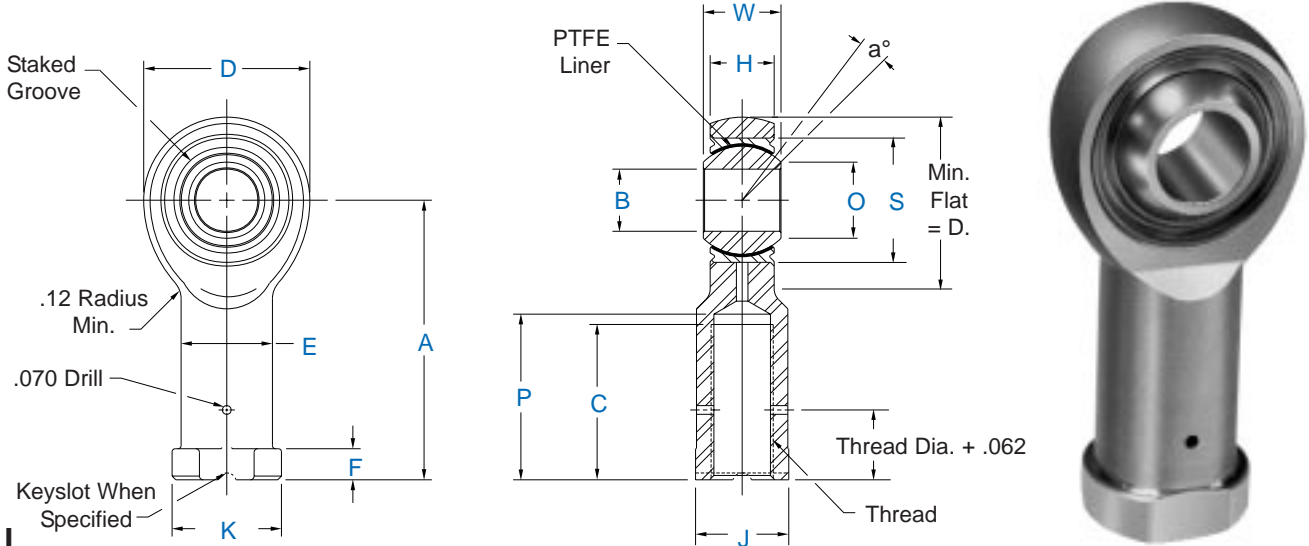

TABLE I

Rod End No.		DIMENSIONS IN INCHES															a°	Approx.
Right Hand	Left Hand	B +.0000 -.0005	W +.000 -.002	H ±.005	A ±.010	D ±.010	O Min.	S Max. Housing I.D.	E ±.010	K Ref. Dia.	J +.002 -.010	F +.010 -.062	Ball Dia. Ref.	P Max.	C Min.	Thread UNJF-3B	Misalign. Angle Min.	Brg. Wt. Lbs.
ASW-3T	ASG-3T	.1900	.437	.337	1.375	.806	.300	.6250	.422	.500	.437	.188	.531	.875	.750	5/16-24	15	.080
ASW-4T	ASG-4T	.2500	.437	.337	1.469	.806	.300	.6250	.422	.500	.437	.188	.531	.875	.750	5/16-24	15	.084
ASW-5T	ASG-5T	.3125	.437	.327	1.625	.900	.360	.6875	.485	.580	.500	.250	.593	1.000	.875	3/8-24	14	.102
ASW-6T	ASG-6T	.3750	.500	.416	1.812	1.025	.470	.8125	.547	.660	.562	.250	.687	1.125	1.000	3/8-24	8	.161
ASW-7T	ASG-7T	.4375	.562	.452	2.000	1.150	.540	.9062	.610	.720	.625	.250	.781	1.250	1.125	7/16-20	10	.212
ASW-8T	ASG-8T	.5000	.625	.515	2.250	1.337	.610	1.0000	.735	.880	.750	.250	.875	1.375	1.250	1/2-20	9	.325
ASW-10T	ASG-10T	.6250	.750	.577	2.500	1.525	.750	1.1875	.860	1.020	.875	.375	1.062	1.500	1.375	5/8-18	12	.481
ASW-12T	ASG-12T	.7500	.875	.640	2.875	1.775	.850	1.3750	.985	1.160	1.000	.375	1.250	1.750	1.625	3/4-16	13	.673
ASW-14T	ASG-14T	.8750	.875	.765	3.375	2.025	1.000	1.6250	1.110	1.300	1.125	.500	1.375	2.062	1.875	7/8-14	6	.959
ASW-16T	ASG-16T	1.0000	1.375	1.015	4.125	2.775	1.270	2.1250	1.688	2.020	1.750	.563	1.875	2.312	2.125	1 1/4-12	12	2.717

Specifications	
BODY	4340 Alloy Steel (MIL-S-5000) Heat Treated Cadmium Plated
BALL	440C Stainless Steel (AMS 5630) Heat Treated Hard Chrome Plated
RACE	17-4 PH Stainless Steel (AMS 5643) Heat Treated
LINER	AT 3200 Bearing Liner, Permanently Bonded to Race I.D. Qualified to SAE-AS81820

Temperature Range: -65°F to + 325°F
 *No load rotational breakaway torque can be varied to meet specific application requirements.
 Add Letter "K" to prefix to designate keyway, Ex. : ASWK-6T.
 As applicable, keyway will conform to SAE-AS81935/3 or NAS 559.
 All threads conform to UNJF-3B per MIL-S-8879.
 AT 3200 Bearing Liner System is qualified for procurement under SAE-AS81820.
 Rod End Bearings listed are manufactured to conform to the dimensions, materials and configurations of SAE-AS81935/2, and are approved for procurement under this specification. Consult factory for additional information.

Rod End No.		Ultimate Radial Static Load Lbs.	Fatigue Load Lbs.	Axial Proof Load Lbs.	No Load Rotational Breakaway Torque* In-Lbs.	
Right Hand	Left Hand				Min.	Max.
ASW-3T	ASG-3T	2,360	1,470	1,000	.5	6
ASW-4T	ASG-4T	4,860	2,380	1,000	.5	6
ASW-5T	ASG-5T	7,180	3,020	1,100	1	15
ASW-6T	ASG-6T	8,550	3,570	1,660	1	15
ASW-7T	ASG-7T	12,000	4,800	1,850	1	15
ASW-8T	ASG-8T	19,500	8,260	2,040	1	15
ASW-10T	ASG-10T	21,900	9,180	2,430	1	15
ASW-12T	ASG-12T	29,300	11,600	2,810	1	15
ASW-14T	ASG-14T	34,500	13,100	3,320	1	24
ASW-16T	ASG-16T	80,300	30,400	4,340	1	24

**THESE BEARINGS NOT NORMALLY STOCKED
 CHECK FOR AVAILABILITY.**



ANC-T & ANC-TG Spherical Bearings

Narrow - Aerospace Series

SAE-AS14101 and SAE-AS14104

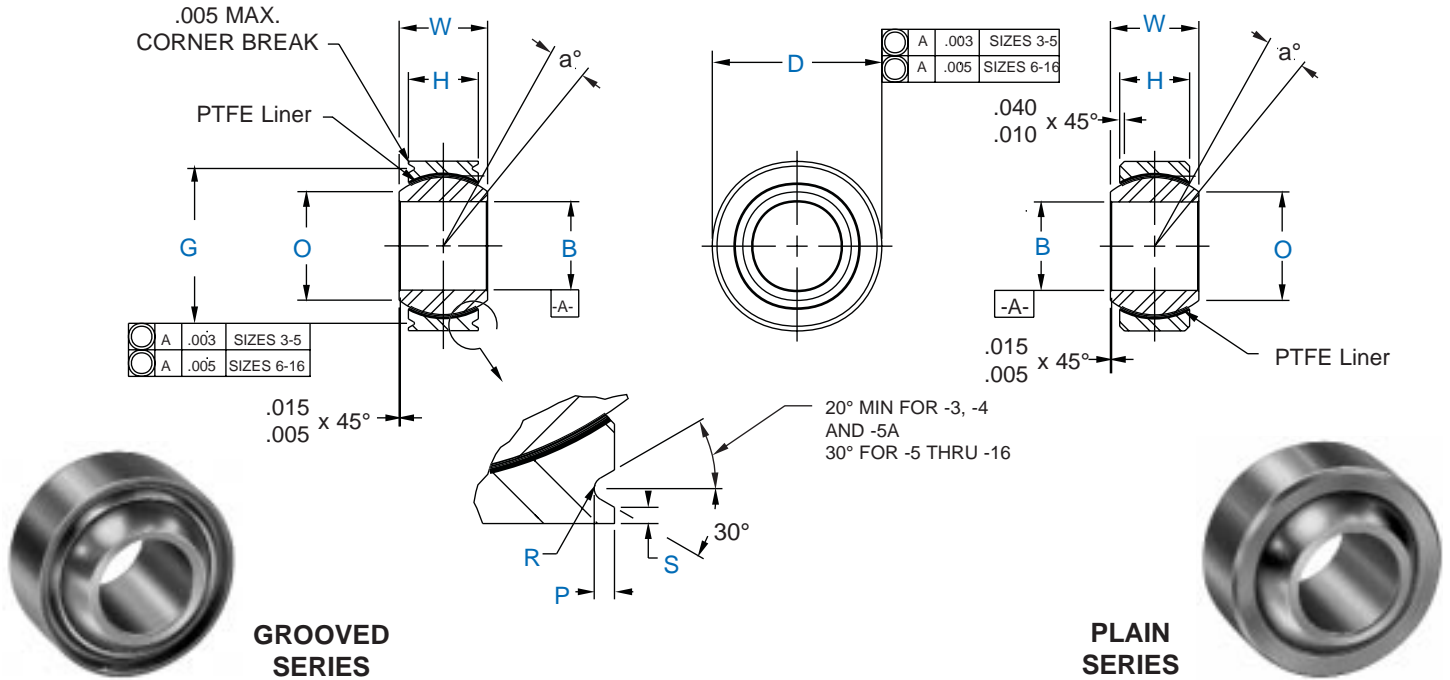

Rod End No.		DIMENSIONS IN INCHES										Ball Dia. Ref.	a°	Static Limit Load		Oscillat-ing Load Lbs.	No Load Rotational Breakaway Torque* in-Lbs.	Aprox. Brg. Wt. Lbs.
Grooved	Plain	B	D	W	H	O	P	S	G	R	Radial Lbs.			Axial Lbs.				
ANC-3TG	ANC-3T	.1900	.5625	.281	.218	.293	.025	.010	.500	.010	.406	10	3,975	150	1,500	0.25 - 5.0	.020	
ANC-4TG	ANC-4T	.2500	.6562	.343	.250	.364	.025	.010	.594	.010	.500	10	6,040	430	3,320	0.25 - 5.0	.020	
ANC-5TG	ANC-5T	.3125	.7500	.375	.281	.419	.035	.020	.650	.010	.562	10	8,750	700	5,460	0.25 - 8.0	.030	
ANC-6TG	ANC-6T	.3750	.8125	.406	.312	.475	.035	.020	.712	.015	.625	9	10,540	1,100	6,600	0.25 - 8.0	.040	
ANC-7TG	ANC-7T	.4375	.9062	.437	.343	.530	.035	.020	.806	.015	.687	8	13,200	1,400	8,050	0.25 - 8.0	.050	
ANC-8TG	ANC-8T	.5000	1.0000	.500	.390	.600	.055	.020	.876	.015	.781	8	17,900	2,100	10,400	0.25 - 8.0	.070	
ANC-9TG	ANC-9T	.5625	1.0937	.562	.437	.670	.055	.020	.970	.015	.875	8	23,200	3,680	13,000	0.25 - 8.0	.090	
ANC-10TG	ANC-10T	.6250	1.1875	.625	.500	.739	.055	.020	1.063	.015	.968	8	30,500	4,720	16,450	0.25 - 8.0	.120	
ANC-12TG	ANC-12T	.7500	1.4375	.750	.593	.920	.055	.020	1.313	.015	1.187	8	46,400	6,750	23,600	0.25 - 8.0	.210	
ANC-14TG	ANC-14T	.8750	1.5625	.875	.703	.980	.055	.020	1.438	.015	1.312	8	62,200	9,350	30,250	0.25 - 12.0	.270	
ANC-16TG	ANC-16T	1.0000	1.7500	1.000	.797	1.118	.055	.020	1.626	.015	1.500	9	82,200	12,160	38,000	0.25 - 12.0	.390	

Specifications	
BALL	440C Stainless Steel (AMS 5630) Heat Treated Hard Chrome Plated
RACE	17-4 PH Stainless Steel (AMS 5643) Heat Treated
LINER	AT 3200 Bearing Liner, Permanently Bonded to Race I.D. Qualified to SAE-AS81820

Temperature Range: -65°F to + 325°F

*No load rotational breakaway torque can be varied to meet specific application requirements.

AT 3200 Bearing Liner System is qualified for procurement under SAE-AS81820.

Bearings listed are manufactured to conform to the dimensions, materials and configurations of Military Specifications SAE-AS14101 (grooved) and SAE-AS14104 (plain), and are approved for procurement under this specification. Consult factory for additional information.

**THESE BEARINGS NOT NORMALLY STOCKED
CHECK FOR AVAILABILITY.**



AWC-T & AWC-TG Spherical Bearings
Wide - Aerospace Series
SAE-AS14102 and SAE-AS14103

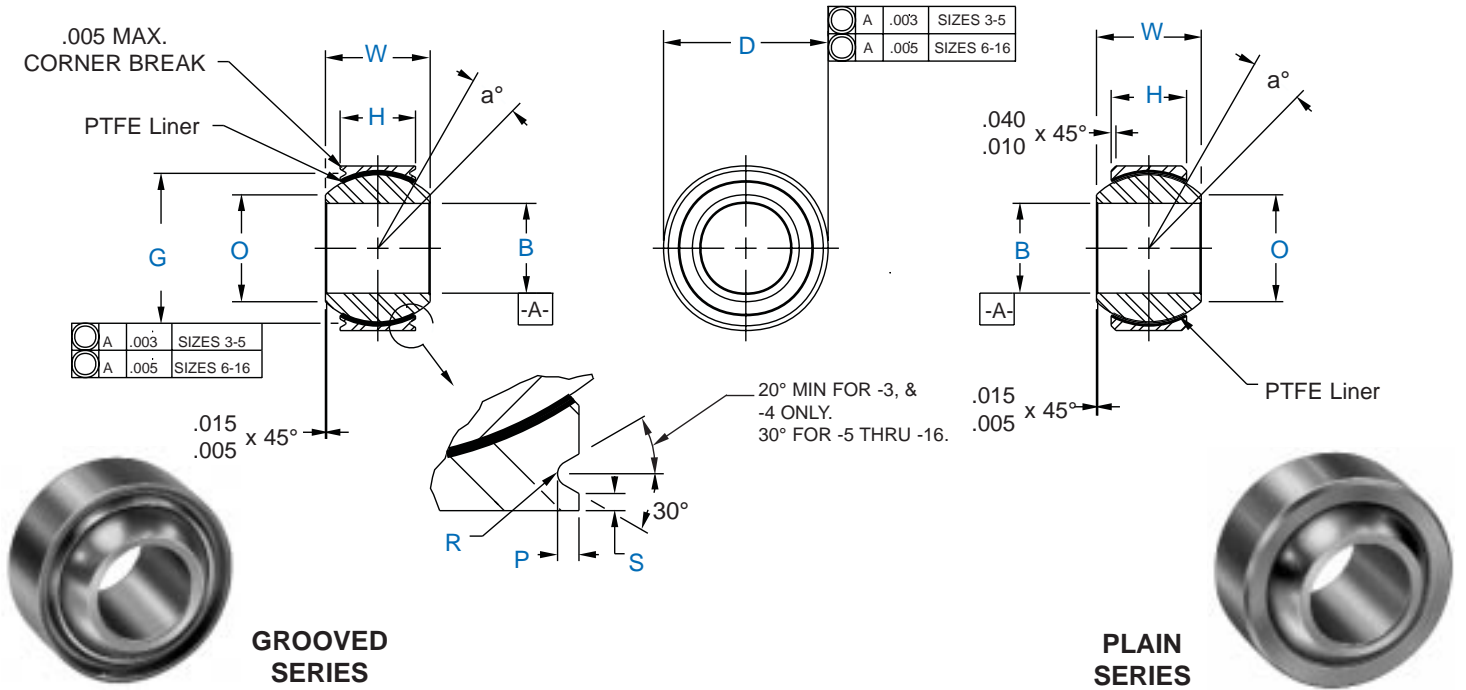

GROOVED SERIES

PLAIN SERIES

Rod End No.		DIMENSIONS IN INCHES										a°	Static Limit Load		Oscillat- -ing Load Lbs.	No Load Rotational Breakaway Torque* in-Lbs.	Aprox. Brg. Wt. Lbs.
Grooved	Plain	B +.0000 -.0005	D +.0000 -.0005	W +.000 -.002	H ±.005	O Min.	P +.000 -.010	S Min.	G +.000 -.008	R +.002 -.005	Ball Dia. Ref.		Radial Lbs.	Axial Lbs.			
AWC-3TG	AWC-3T	.1900	.6250	.437	.327	.300	.025	.010	.563	.010	.531	15	2,500	1,770	4,900	0.25 - 5.0	.031
AWC-4TG	AWC-4T	.2500	.6250	.437	.327	.300	.025	.010	.563	.010	.531	15	5,500	1,770	4,900	0.25 - 5.0	.031
AWC-5TG	AWC-5T	.3125	.6875	.437	.317	.360	.025	.010	.625	.010	.593	14	9,400	1,640	6,050	0.25 - 8.0	.035
AWC-6TG	AWC-6T	.3750	.8125	.500	.406	.466	.035	.020	.712	.015	.687	8	13,700	2,630	8,310	0.25 - 8.0	.060
AWC-7TG	AWC-7T	.4375	.9375	.562	.442	.537	.035	.020	.837	.015	.781	10	20,700	3,650	11,750	0.25 - 8.0	.080
AWC-8TG	AWC-8T	.5000	1.0000	.625	.505	.607	.035	.020	.900	.015	.875	9	21,400	4,970	14,950	0.25 - 8.0	.100
AWC-9TG	AWC-9T	.5625	1.1250	.687	.536	.721	.035	.020	1.025	.015	1.000	10	26,600	5,370	18,100	0.25 - 8.0	.135
AWC-10TG	AWC-10T	.6250	1.1875	.750	.567	.747	.035	.020	1.087	.015	1.062	12	29,000	6,130	20,250	0.25 - 8.0	.160
AWC-12TG	AWC-12T	.7500	1.3750	.875	.630	.845	.055	.020	1.251	.015	1.250	13	37,000	7,730	26,200	0.25 - 8.0	.240
AWC-14TG	AWC-14T	.8750	1.6250	.875	.755	.995	.055	.020	1.501	.015	1.375	6	65,200	10,800	33,600	0.25 - 12.0	.350
AWC-16TG	AWC-16T	1.0000	2.1250	1.375	1.005	1.269	.055	.020	2.001	.015	1.875	12	104,000	19,300	56,250	0.25 - 12.0	.970

Specifications	
BALL	440C Stainless Steel (AMS 5630) Heat Treated Hard Chrome Plated
RACE	17-4 PH Stainless Steel (AMS 5643) Heat Treated
LINER	AT 3200 Bearing Liner, Permanently Bonded to Race I.D. Qualified to SAE-AS81820

Temperature Range: -65°F to + 325°F
 *No load rotational breakaway torque can be varied to meet specific application requirements.
 AT 3200 Bearing Liner System is qualified for procurement under SAE-AS81820.
 Bearings listed are manufactured to conform to the dimensions, materials and configurations of Military Specifications SAE-AS14103 (grooved) and SAE-AS14102 (plain), and are approved for procurement under this specification.
 Consult factory for additional information.

**THESE BEARINGS NOT NORMALLY STOCKED
 CHECK FOR AVAILABILITY.**



GMM-M & GMB-M Series Male Rod Ends General Aviation - Precision

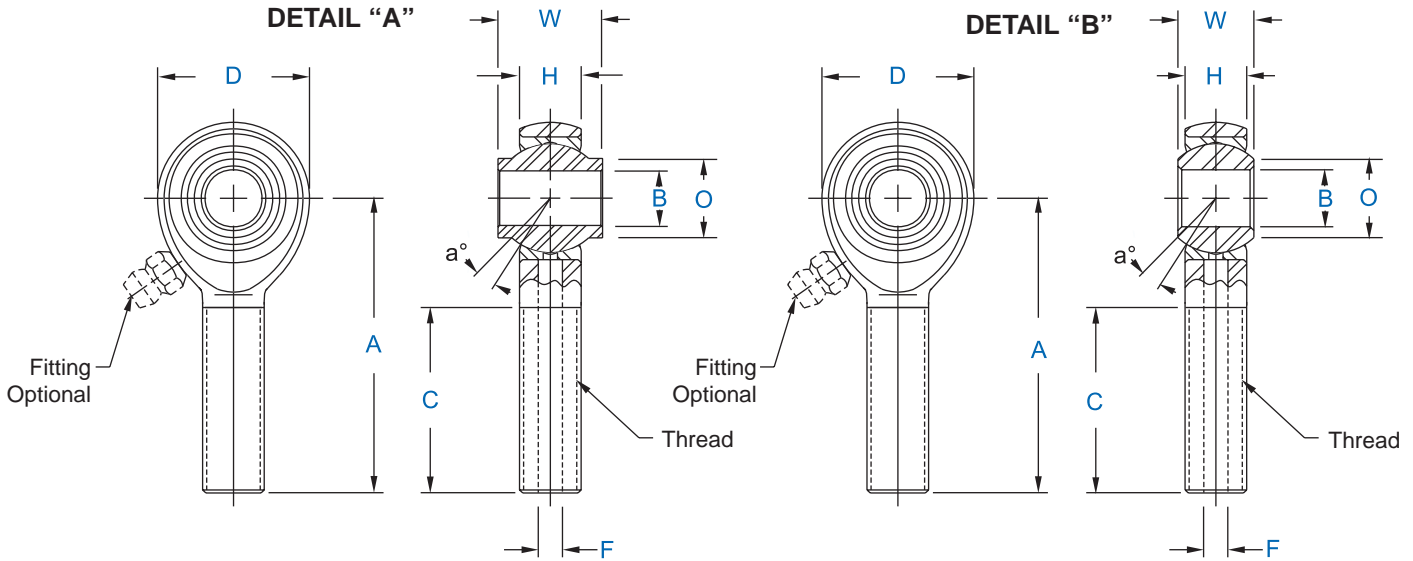

**DETAIL
"A"**

Specifications	
BODY	Carbon steel, protective coated for corrosion resistance.
RACE	Carbon steel, protective coated for corrosion resistance.
BALL	Alloy steel, heat treated, hard chrome plated.



**DETAIL
"B"**

Note: Units are magnetic particle inspected after assembly.

Rod End No.		DIMENSIONS IN INCHES											a°	Ultimate	Approx.
Right Hand	Left Hand	Ball Shoulder Configuration	B +.0015 -.0005	W + .000 - .005	H ±.005	A ±.015	D ±.010	Shoulder Dia. Ref.	Ball Dia. Ref.	C Min.	F Drilled Hole Dia Ref.	Thread UNF-3A	Misalign. Angle	Radial Static Load Capacity Lbs.	Brg. Wt. Lbs.
GMM-3M-470	GMB-3M-470	See Detail "A"	.1900	.437	.281	1.562	.750	.315	.500	.969	-	1/4-28	17	2,158	.05
GMM-3M-570	GMB-3M-570	See Detail "A"	.1900	.437	.328	1.375	.875	.315	.500	.750	.113	5/16-24	10	2,823	.07
GMM-3M-670	GMB-3M-670	See Detail "A"	.1900	.437	.328	1.375	.750	.315	.500	.750	.113	3/8-24	10	2,850	.08
GMM-3M-680	GMB-3M-680	See Detail "B"	.1900	.500	.375	1.812	.833	.319	.593	1.062	.136	3/8-24	18	3,269	.09
GMM-4M-470	GMB-4M-470	See Detail "B"	.2500	.437	.304	1.562	.812	.353	.562	.969	-	1/4-28	18	2,158	.07
GMM-4M-675	GMB-4M-675	See Detail "B"	.2500	.484	.335	2.312	.875	.395	.625	1.500	.136	3/8-24	18	3,160	.11
GMM-4M-680	GMB-4M-680	See Detail "B"	.2500	.500	.335	2.062	.875	.375	.625	1.500	.159	3/8-24	10.5	2,985	.10

Load ratings apply only to rod ends without grease fittings. For load ratings with fittings, please contact our engineering department.

Units are supplied without grease fittings. When a grease fitting is required, specify by adding suffix as designated.

Z Zerk type fitting Ex: GMM-3MZ-470
F Flush type fitting Ex: GMM-3MF-470



GMW-M & GMG-M Series Female Rod Ends General Aviation - Precision

DETAIL "A"

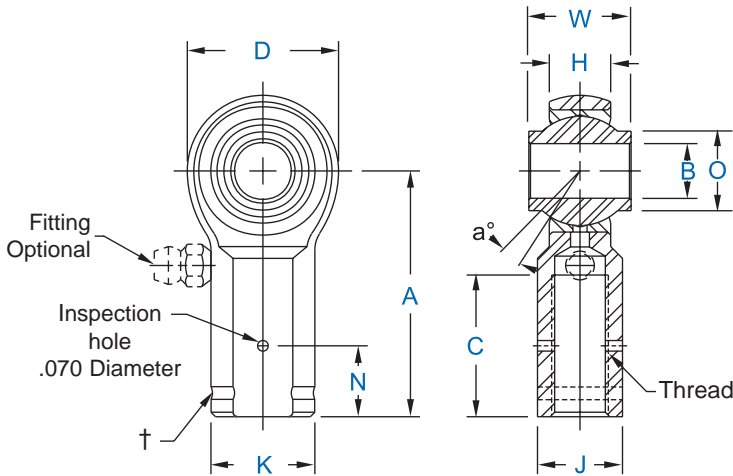

DETAIL "B"

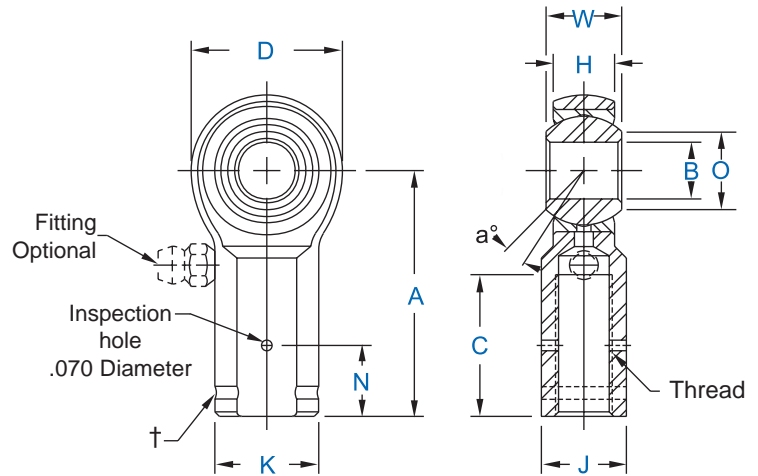

DETAIL "A"



DETAIL "B"

Specifications	
BODY	Carbon steel, protective coated for corrosion resistance.
RACE	Carbon steel, protective coated for corrosion resistance.
BALL	Alloy steel, heat treated, hard chrome plated.

Note: Units are magnetic particle inspected after assembly.

Rod End No.		DIMENSIONS IN INCHES													a° Misalign. Angle	Ultimate Radial Static Load Capacity Lbs.	Approx. Brg. Wt. Lbs.
Right Hand	Left Hand†	Ball Shoulder Configuration	B +.0015 -.0005	W +.000 -.005	H ±.005	A ±.015	D ±.010	K ±.010	J ±.010	N ±.005	O Shoulder Dia. Ref.	Ball Dia. Ref.	C +.062 -.031	Thread UNF-3B			
GMW-3M-470	GMG-3M-470	See Detail "A"	.1900	.437	.328	1.375	.750	.468	.375	.312	.315	.500	.750	1/4-28	10	2,881	.06
GMW-3M-471	GMG-3M-471	See Detail "A"	.1900	.437	.328	1.062	.750	.375	-	-	.315	.500	.437	1/4-28	10	2,881	.05
GMW-3M-480	GMG-3M-480	See Detail "A"	.1900	.500	.375	1.375	.812	.468	.375	.312	.312	.562	.750	1/4-28	15	3,152	.08
GMW-3M-570	GMG-3M-570	See Detail "A"	.1900	.437	.328	1.375	.750	.500	.437	.312	.315	.500	.750	5/16-24	10	2,881	.07
GMW-4M-470	GMG-4M-470	See Detail "B"	.2500	.437	.304	1.375	.812	.468	.375	.312	.353	.562	.750	1/4-28	18	2,950	.08
GMW-4M-595	GMG-4M-595	See Detail "A"	.2500	.593	.406	1.469	.938	.500	-	.312	.485	.687	.844	5/16-24	10	3,359	.10

† Left hand units identification groove near end of shank.

Units are supplied without grease fittings. When a grease fitting is required, specify by adding suffix as designated.

Z Zerk type fitting Ex: GMW-3MZ-470

F Flush type fitting Ex: GMW-3MF-470

Load ratings apply only to rod ends without grease fittings. For load ratings with fittings, please consult our engineering department.



INSTALLATION OF SPHERICAL BEARING

FIGURE 1

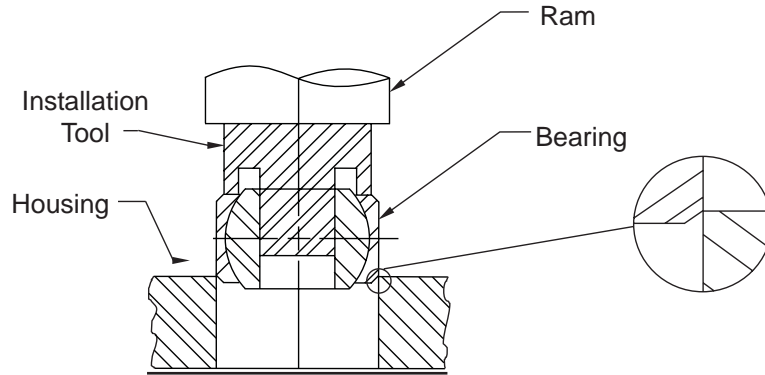

SPHERICAL BEARING INSTALLATION

Proper installation of the bearing is important to prevent bearing failure as well as housing damage. Under no circumstances should a tool that induces shock or impact to the bearing be used. The use of an arbor press or hydraulic press is recommended. A tool as shown above (Figure 1) is advised. All force is to be applied on the bearing race face (not on ball). A lead chamfer or radius on the bearing and/or housing is vital.

HOUSING CHAMFER - GROOVED BEARINGS

CHAMFER FOR GROOVE TYPES	
GROOVE TYPE A	.020 ± .005
GROOVE TYPE B	.030 ± .005
GROOVE TYPE C	.050 ± .005

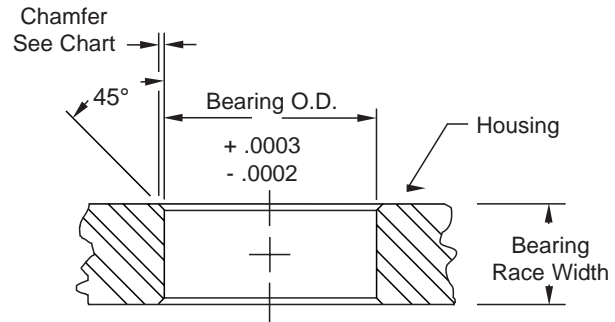

STAKING GROOVE TYPES

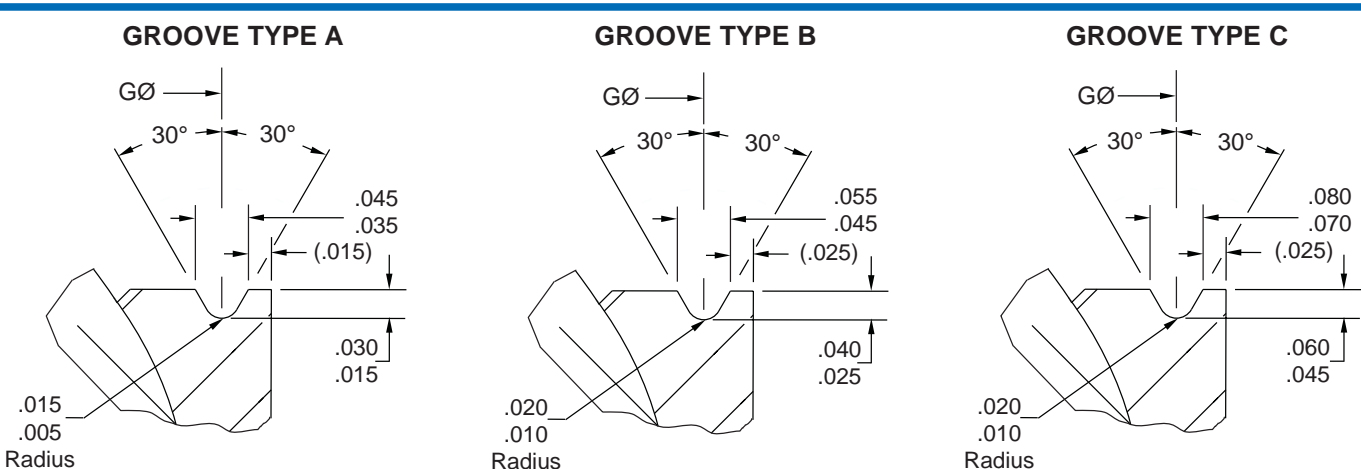



INSTALLATION OF SPHERICAL BEARING WITH STAKING GROOVES TOOLS AND STAKING METHODS

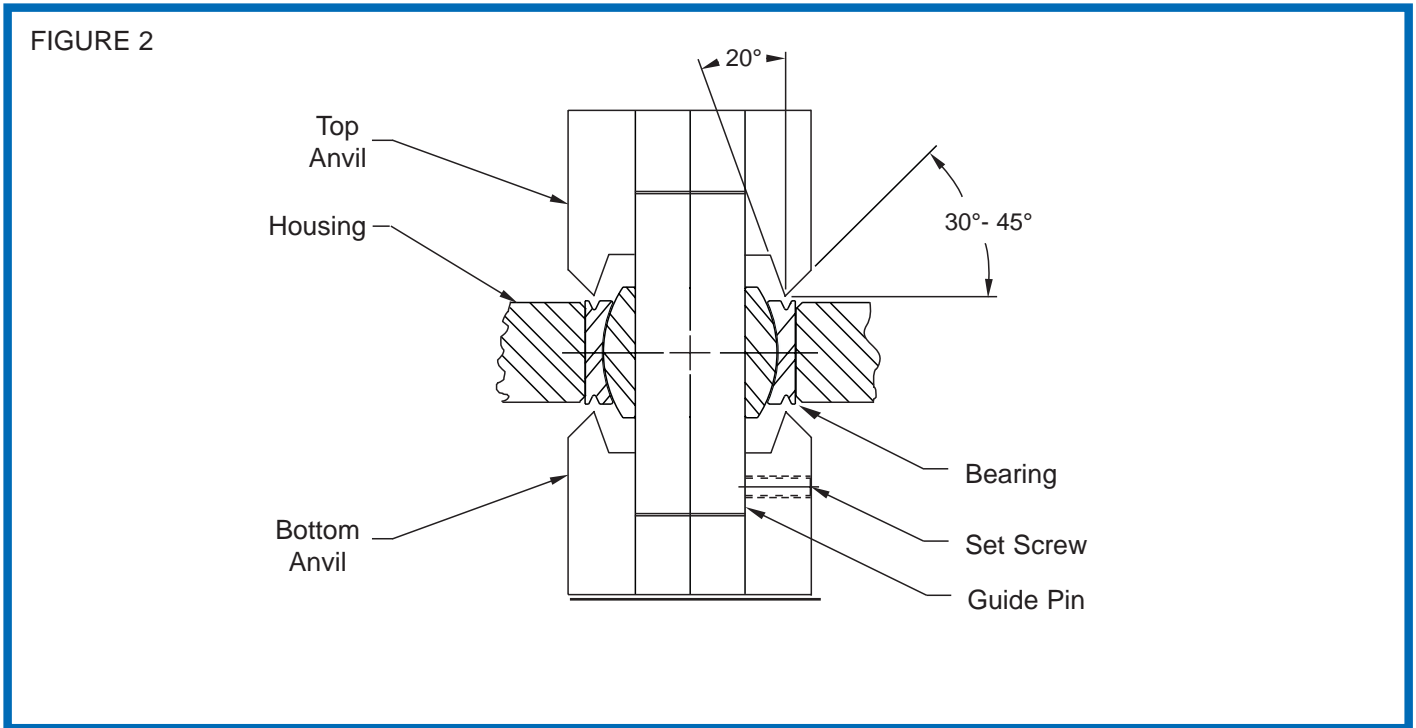

SPHERICAL BEARING INSTALLATION

The bearings have grooves in each side of the bearing race face, leaving a small lip. Staking tools (as shown above in Figure 2) are then used to stake the lip over the chamfer edges of the housing. A typical arrangement consists of two identical anvils and one guide pin which is secured by a set screw in the bottom anvil.

PROCEDURES

1. Install bearing into housing as shown in Figure 1 (pg. 64) and position bearing symmetrical about housing centerline.
2. Align bearing with staking tool and guide pin as shown in Figure 2.
3. A trial stake assembly should be made to determine staking force necessary to meet thrust load requirements. Proper staking force is required because excessive pressure could result in bearing distortion along with life.
4. Pressure established by trial assembly is to be applied. After first stake is completed rotate assembly 90° and re-apply. Repeat operation through a minimum of three rotations to insure 360° uniformity of stake.
5. After staking, a slight gap may exist between race lip and housing chamfer. This slight gap (shown below) may not be cause for rejection if bearing meets or exceeds thrust loads.

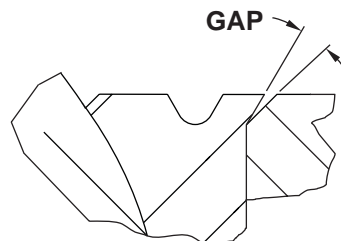



Most commonly used conversions in **Bold**.

INCH/METRIC CONVERSION TABLE

INCH		MM.	INCH		MM.	INCH		MM.	INCH		MM.
FRACT.	DEC.		FRACT.	DEC.		FRACT.	DEC.		FRACT.	DEC.	
	0.00004	0.001	17/64	0.2656	6.746		0.6693	17.0		1.3780	35.0
	0.00039	0.01		0.2756	7.0	43/64	0.6719	17.066		1.4173	36.0
	0.0010	0.025	9/32	0.2812	7.1437	11/16	0.6875	17.4625	1 1/2	1.5000	38.1
	0.0020	0.051	19/64	0.2969	7.5406	45/64	0.7031	17.859		1.5354	39.0
	0.0030	0.0762	5/16	0.3125	7.9375		0.7086	18.0		1.5748	40.0
	0.00394	0.1		0.3150	8.0	23/32	0.7187	18.256		1.6535	42.0
	0.0050	0.1270	21/64	0.3281	8.334	47/64	0.7334	18.653	1 3/4	1.7500	44.45
	0.00984	0.25	11/32	0.3437	8.731		0.7480	19.0		1.7717	45.0
	0.0100	0.254		0.3543	9.0	3/4	0.7500	19.05		1.8898	48.0
1/64	0.0156	0.396	23/64	0.3594	9.1281	49/64	0.7656	19.446		1.9685	50.0
1/32	0.0312	0.793	3/8	0.3750	9.525	25/32	0.7815	19.843	2	2.0000	50.8
	0.03937	1.0	25/64	0.3906	9.9219		0.7874	20.0		2.0472	52.0
3/64	0.0469	1.191		0.3937	10.0	51/64	0.7969	20.240		2.1654	55.0
	0.0591	1.5	13/32	0.4062	10.318	13/16	0.8125	20.6375		2.2047	56.0
1/16	0.0625	1.5875	27/64	0.4219	10.716		0.8268	21.0	2 1/4	2.2500	57.15
5/64	0.0781	1.984		0.4331	11.0	53/64	0.8281	21.034		2.3622	60.0
	0.0787	2.0	7/16	0.4375	11.125	27/32	0.8437	21.431	2 1/2	2.5000	63.5
3/32	0.0937	2.381	29/64	0.4531	11.509	55/64	0.8594	21.828		2.5197	64.0
	0.0984	2.5	15/32	0.4687	11.906		0.8661	22.0	2 3/4	2.7500	69.85
	0.1000	2.54		0.4724	12.0	7/8	0.8750	22.225		2.8346	72.0
7/64	0.1094	2.778	31/64	0.4844	12.303	57/64	0.8906	22.621		2.9528	75.0
	0.1181	3.0	1/2	0.5000	12.7		0.9055	23.0	3	3.0000	76.2
1/8	0.1250	3.175		0.5118	13.0	29/32	0.9062	23.018		3.1496	80.0
	0.1387	3.5	33/64	0.5156	13.096	59/64	0.9219	23.416	3 1/4	3.2500	82.55
9/64	0.1406	3.571	17/32	0.5312	13.493	15/16	0.9375	23.8125	3 1/2	3.5000	88.9
5/32	0.1562	3.968	35/64	0.5469	13.891		0.9449	24.0		3.5433	90.0
	0.1575	4.0		0.5512	14.0	61/64	0.9531	24.209	3 3/4	3.7500	95.25
11/64	0.1719	4.366	9/16	0.5625	14.2875	31/32	0.9687	24.606		3.9370	100.0
	0.1772	4.5	37/64	0.5781	14.684		0.9843	25.0	4	4.0000	101.6
3/16	0.1875	4.7625		0.5906	15.0	63/64	0.9844	25.003	4 1/4	4.2500	107.95
	0.1969	5.0	19/32	0.5937	15.081	1	1.0000	25.4		4.3307	110.0
13/64	0.2031	5.159	39/64	0.6094	15.478		1.0630	27.0	4 1/2	4.5000	114.3
7/32	0.2187	5.556	5/8	0.6250	15.875		1.1024	28.0		4.7244	120.0
15/64	0.2334	5.953		0.6299	16.0		1.1811	30.0	4 3/4	4.7500	120.65
	0.2362	6.0	41/64	0.6406	16.271	1 1/4	1.2500	31.75	5	5.0000	127.0
1/4	0.2500	6.35	21/32	0.6562	16.668		1.2992	33.0	5 1/2	5.5000	139.7

INCH/METRIC CONVERSION FACTORS

Inches x 25.4 = Millimeters
 Millimeters x .03937 = Inches
 Sq. Inches x 6.4515 = Sq. Centimeters
 Sq. Centimeters x .155 = Sq. Inches

Pounds x .4536 = Kilograms
 Kilograms x 2.2046 = Pounds
 Lbs. per In.² x .0703 = kg per cm²
 kg per cm² x 14.2231 = Lbs. per In.²

Pounds(Force) x 4.448 =Newtons
 Newtons x .2248 =Pounds(Force)
 Temperature Conversion (Approximate)
 Degrees C = (Degrees F -32)(.5556)
 Degrees F = (Degrees C)(1.8)+ 32



ENGINEERING INFORMATION

TAP DRILL SIZES FOR INCH THREADS			
Screw Thread		Commercial Tap Drills	
Thread size	Root Dia.	Size or Number	Decimal Equiv.
6-32	0.0834	36	0.1065
10-32	0.1469	22	0.1570
1/4-28	0.2036	3	0.2130
5/16-24	0.2584	I	0.2720
3/8-24	0.3209	Q	0.3320
7/16-20	0.3726	25/64	0.3906
1/2-13	0.4001	27/64	0.4219
1/2-20	0.4351	29/64	0.4531
5/8-11	0.5069	17/32	0.5312
5/8-18	0.5528	37/64	0.5781
3/4-16	0.6688	11/16	0.6875
7/8-14	0.7822	13/16	0.8125
1-12	0.8918	59/64	0.9219
1-14	0.9072	15/16	0.9375
1 1/4-12	1.1418	1 11/64	1.1719
1 1/2-12	1.3918	1 27/64	1.4219
1 3/4-12	1.6050	1 21/32	1.6563
2-12	1.8557	1 29/32	1.9063

TAP DRILL SIZE METRIC THREADS	
THREAD SIZE/TAP	METRIC DRILL SIZE
M3 X 0.5	2.50
M5 X 0.8	4.20
M6 X 1.0	5.00
M8 X 1.25	6.80
M10 X 1.5	8.50
M12 X 1.75	10.20
M14 X 2.0	12.00
M16 X 2.0	14.00
M18 X 1.5	16.50
M20 X 1.5	18.50
M22 X 1.5	20.5
M24 X 2.0	22.0
M30 X 2.0	28.0

The tables above are to be used as guides only. Consult the appropriate reference to determine best size based on fit requirements, materials used, etc.

STEEL DESIGNATION CROSS REFERENCE TABLE

USA	BRITAIN	FRANCE	GERMANY	ITALY	JAPAN
AISI	B.S.	AFNOR	DIN	UNI	JIS
1015	080 M 15	XC 15	Ck 15	C 15	S 15 C
1018	080 A 17		C 16.8		
1022	120 M 19	20 M 5	20 Mn 5	G 22 Mn 3	SMnC 420
1114	212 M 44				SUM 43
1215	240 M 07	S 300	9 SMn 36	CF 9 Mn 36	SUM 23
4130	1717 CDS 110	25 CD 4	25 CrMo 4	25 CrMo 4	SCM 420
4140	708 M 40	42 CD 4 TS	41 CrMo 4	41 CrMo	SCM 440
4340	817 M 40	35 NCD 6	24 CrNiMo 6	35 NiCrMo 6	SNCM 447
52100	534 A 99	100 C 6	100 Cr 6	100 Cr 6	SUJ 2
303	303 S 21	Z 10 CNF 18.09	X 10 CrNiS 18 9	X 10 CrNiS 1809	SUS 303
410	410 S 21	Z 3 C 14	X7 Cr 14	X 12Cr 13	SUS 51
440C		Z 100 CD 17	X 105 CrMo 17		SUS 57
17-4		Z 5 CNU 17.4	X 5 CrNiCuNb 17 14		SUS 80

This table is to be used as a guide to assist in finding comparable metal designations only. True interchange can be determined only by comparing chemical composition, mechanical properties, and manufacturing technologies.

SPECIALLY DESIGNED ROD ENDS AND LINKAGES

from The Motion-Transfer Specialists.
Illustrated are a variety of special linkages
and rod ends. Let us design specials to
meet your specific applications.



AURORA

BEARING COMPANY

Aurora Bearing Co.
970 South Lake St.
Aurora, IL 60506
U.S.A.

aurora_rodends@aurorabearing.com

PHONE: (630) 859-2030
FAX: (630) 859-0971
www.aurorabearing.com